

**Model ZR22S, ZR402G  
Separate type Explosion-proof  
Zirconia Oxygen Analyzer**

IM 11M13A01-02E

---

# ◆ Introduction

Thank you for purchasing the ZR22S, ZR402G Separate type Explosion-proof Zirconia Oxygen Analyzer.

Please read the following respective documents before installing and using the ZR22S, ZR402G Separate type Explosion-proof Zirconia Oxygen Analyzer.

The related documents are as follows.

### General Specifications

Contents	Document number	Note
Model ZR22S and ZR202S Explosion-proof Direct In Situ Zirconia Oxygen Analyzers	GS 11M13A01-01E	

\* the "E" in the document number is the language code.

### User's Manual

Contents	Document number	Note
Model ZR22S, ZR402G Separate type Explosion-proof Zirconia Oxygen Analyzer	IM 11M13A01-02E	(This manual)
Model ZR22A, ZR202A Heater Assembly	IM 11M12A01-21E	
Model EXAxt ZR Series HART Protocol	IM 11M12A01-51E	

\* the "E" in the document number is the language code.

An exclusive User's Manual might be attached to the products whose suffix codes or option codes contain the code "Z" (made to customers' specifications). Please read it along with this manual.

The EXAxt ZR Separate type Explosion-proof Zirconia Oxygen Analyzer has been developed for combustion control in various industrial processes. This analyzer basically consists of a detector and a converter. You can select between several versions, based upon your application.

Optional accessories are also available to improve measurement accuracy and automate calibration. An optimal control system can be realized by adding appropriate options.

This instruction manual refers to almost all of the equipment related to the EXAxt ZR. You may skip any section(s) on the equipment which is not included in your system.

Regarding the HART communication protocol, refer to IM 11M12A01-51E.

IM 11M12A01-51E has been published as " Model EXAxt ZR Series HART Protocol" .

The all-in-one version (with sensor and analyzer integrated in one body) is described in IM 11M12A01-04E

Before using the equipment, please read any description in this manual related to the equipment and the system, on appropriate use and operation of the EXAxt ZR.

**Models and descriptions in this manual**

Model	Product Name	Description in this manual				
		Specification	Installation	Operation	Maintenance	CMPL
ZR22S	General-purpose detector	○	○	○	○	○
ZR22S	High temperature detector (0.15 m)	○	○	○	○	
ZR402G	Converter	○	○	○	○	○
ZO21R	Probe protector	○	○			
ZO21P	High temperature probe adapter	○	○			○
ZA8F	Flow setting unit (for manual calibration use)	○	○	○		○
ZR40H	Automatic Calibration unit	○	○	○		○
-	Auxiliary ejector assembly for high temperature use (Part No. E7046EC, 7046EN)	○	○			○
-	Calibration gas unit case (Part No. E7044KF)	○	○			
-	Check valve (Part No.9292DN, K9292DS)	○	○			
ZO21S	Standard gas unit	○		○	○	○

CMPL : Customer Maintenance Parts List

This manual consists of twelve chapters. Please refer to the reference chapters for installation, operation and maintenance.

**Table of Contents**

Chapter	Outline	Relates to		
		Installation	Operation	Maintenance
1. Overview	Equipment models and system configuration examples	B	C	B
2. Specifications	Standard specification, model code (or part number), dimension drawing for each equipment	A	B	B
3. Installation	Installation method for each equipment	A		C
4. Piping	Examples of piping in two standard system configurations	A		C
5. Wiring	Wiring procedures such as “Power supply wiring”, “output signal wiring” or others	A		C
6. Components and Their Functions	Major parts and function are described in this manual	C	B	B
7. Startup	Basic procedure to start operation of EXAxt ZR. Chapter 7 enables you to operate the equipment immediately.		A	C
8. Detailed Data Setting	Details of key operations and displays		B	C
9. Calibration	Describes the calibration procedure required in the course of operation.		B	C
10. Other Functions	Other functions described		B	C
11. Inspection and Maintenance	How to conduct maintenance of EXAxt ZR and procedures for replacement of deteriorated parts		B	A
12. Troubleshooting	This chapter describes measures to be taken when an abnormal condition occurs.		C	A
CMPL (parts list)	User replaceable parts list		C	B

A : Read and completely understand before operating the equipment.  
 B : Read before operating the equipment, and refer to it whenever necessary.  
 C : Recommended to read it at least once.

## ■ Precautions in Handling Explosion-proof Zirconia Oxygen Analyzer

The explosion-proof zirconia oxygen analyzer (Model ZR22S) are designed as explosion-proof instruments.

When using either of these instruments in an explosion-susceptible hazardous area, note the following and observe the given precautions:

Use only the supplied, the explosion-proof zirconia oxygen analyzer (Model ZR22S) and accessories, or any explosion-proof certification may be invalidated.

For the details, refer to the system configurations in the manual.

### CAUTION

Only trained persons use this instrument in industrial locations.

Explosion-proof Approval followings:

ZR22S-A (ATEX);	Ex db IIB+H <sub>2</sub> T2 Gb, Ex tb IIIC T300°C Db
ZR22S-B (FM);	Class I, Division 1, Groups B, C and D, Class II/III, Division 1, Groups E, F and G, T2
ZR22S-C (CSA);	Class I, Division 1, Groups B, C and D, Class II/III, Division 1, Groups E, F and G, T2
ZR22S-D (IECEX);	Ex db IIB+H <sub>2</sub> T2 Gb, Ex tb IIIC T300°C Db
ZR22S-K (KOSHA);	Ex d IIB+H <sub>2</sub> T2

## ■ For the safe use of this equipment

### WARNING

EXAxtZR is very heavy. Handle it with care. Do not drop it. Handle safely to avoid injury.

Connect the power supply cord only after confirming that the supply voltage matches the rating of this equipment. In addition, confirm that the power is switched off when connecting power supply.

Some process gas is dangerous to people. When removing this equipment from the process line for maintenance or other reasons, protect yourself from potential poisoning by using a protective mask or ventilating the area well.

### CAUTION

Requirements for explosion-proof use:

The ZR22S is connected to a ZR402G or AV550G\*<sup>1</sup> that is mounted in a non-hazardous area.

The ambient temperature is in the range -20 to +60°C. The surface temperature of the ZR22S is not over the temperature class T2 (300°C)\*<sup>2</sup>.

\*1: Refer to IM 11M12D01-01E

\*2: The terminal box temperature does not exceed 150°C

Oxygen concentration of sample/reference /calibration gas shall not exceed that found in normal air, typically 21 vol%.

---

**NOTE**

The cell (sensor) at the tip of the detector is made of ceramic (zirconia element). Do not drop the detector or subject it to pressure stress.

- Do NOT allow the sensor (probe tip) to make contact with anything when installing the detector.
  - Avoid any water dropping directly on the probe (sensor) of the detector when installing it.
  - Check the calibration gas piping before introducing the calibration gas to ensure that there is no leakage of the gas. If there is any leakage of the gas, the moisture drawn from the sample gas may damage the sensor.
  - The detector (especially at the tip) becomes very hot. Be sure to handle it with gloves.
- 

**CAUTION**

---

This instrument is tested and certificated as explosion-proof type. Please note that the construction of the instrument, installation, external wiring, maintenance or repair is strictly restricted, and non-observation or negligence of this restriction would result in dangerous condition.

---

**● Specification check**

When the instrument arrives, unpack the package with care and check that the instrument has not been damaged during transportation. In addition, please check that the specification matches the order, and required accessories are not missing. Specifications can be checked by the model codes on the nameplate. Refer to Chapter 2 Specifications for the list of model codes.

# ◆ Safety Precautions

## ■ Safety, Protection, and Modification of the Product

- In order to protect the system controlled by the product and the product itself and ensure safe operation, observe the safety precautions described in this user’s manual. We assume no liability for safety if users fail to observe these instructions when operating the product.
- If this instrument is used in a manner not specified in this user’s manual, the protection provided by this instrument may be impaired.
- If any protection or safety circuit is required for the system controlled by the product or for the product itself, prepare it separately.
- Be sure to use the spare parts approved by Yokogawa Electric Corporation (hereafter simply referred to as YOKOGAWA) when replacing parts or consumables.
- Modification of the product is strictly prohibited.
- The following safety symbols are used on the product as well as in this manual.

### **WARNING**

This symbol indicates that an operator must follow the instructions laid out in this manual in order to avoid the risks, for the human body, of injury, electric shock, or fatalities. The manual describes what special care the operator must take to avoid such risks.

### **CAUTION**

This symbol indicates that the operator must refer to the instructions in this manual in order to prevent the instrument (hardware) or software from being damaged, or a system failure from occurring.

### **CAUTION**

This symbol gives information essential for understanding the operations and functions.

### **NOTE**

This symbol indicates information that complements the present topic.



Protective Ground Terminal



Function Ground Terminal (Do not use this terminal as the protective ground terminal.)



Alternating current

- Special descriptions in this manual

This manual indicates operation keys, displays and drawings on the product as follows:

- Operation keys, Enclosed in [ ], displays on the panel “ “.
  - (Ex. [MODE] key)
  - (Ex. selection display → “ BASE “)
  - (Ex. data display → “ 102” lit, “ 102” flashing)

- Drawing for flashing  
Indicated in light print.

(Flashing)  (lit) 

---

## ■ Warning and Disclaimer

The product is provided on an “as is” basis. YOKOGAWA shall have neither liability nor responsibility to any person or entity with respect to any direct or indirect loss or damage arising from using the product or any defect of the product that YOKOGAWA can not predict in advance.

## ■ Notes on Handling User’s Manuals

- Please hand over the user’s manuals to your end users so that they can keep the user’s manuals on hand for convenient reference.
- Please read the information thoroughly before using the product.
- The purpose of these user’s manuals is not to warrant that the product is well suited to any particular purpose but rather to describe the functional details of the product.
- No part of the user’s manuals may be transferred or reproduced without prior written consent from YOKOGAWA.
- YOKOGAWA reserves the right to make improvements in the user’s manuals and product at any time, without notice or obligation.
- If you have any questions, or you find mistakes or omissions in the user’s manuals, please contact our sales representative or your local distributor.

## ■ Drawing Conventions

Some drawings may be partially emphasized, simplified, or omitted, for the convenience of description.

Some screen images depicted in the user’s manual may have different display positions or character types (e.g., the upper / lower case). Also note that some of the images contained in this user’s manual are display examples.

## ■ Product Disposal:

The instrument should be disposed of in accordance with local and national legislation/regulations.

## ■ Trademark Acknowledgments

- All other company and product names mentioned in this user’s manual are trademarks or registered trademarks of their respective companies.
- We do not use TM or ® mark to indicate those trademarks or registered trademarks in this user’s manual.

# ◆ CE marking products

## ■ Authorized Representative in EEA

The Authorized Representative for this product in EEA is Yokogawa Europe B.V. (Euroweg 2, 3825 HD Amersfoort, The Netherlands).

## ■ Identification Tag

This manual and the identification tag attached on packing box are essential parts of the product. Keep them together in a safe place for future reference.

## ■ Users

This product is designed to be used by a person with specialized knowledge.

### ● How to dispose the batteries (Only for ZR402G):

This is an explanation about the EU Battery Directive. This directive is only valid in the EU. Batteries are included in this product. Batteries incorporated into this product cannot be removed by yourself. Dispose them together with this product.

Battery type: Manganese dioxide lithium battery



Notice:

The symbol (see above) means they shall be sorted out and collected as ordained in the EU Battery Directive.

## ■ Information of the WEEE Directive

This product is purposely designed to be used in a large scale fixed installations only and, therefore, is out of scope of the WEEE Directive. The WEEE Directive does not apply. This product should be disposed in accordance with local and national legislation/regulations. The WEEE Directive is only valid in the EU.



## ◆ After-Sales Warranty

- **Do not modify the product.**
- **Yokogawa warrants the product for the period stated in the pre-purchase quotation. Yokogawa shall conduct defined warranty service based on its standard.**
- **During the warranty period, for repair under warranty carry or send the product to the local sales representative or service office. Yokogawa will replace or repair any damaged parts and return the product to you.**
  - Before returning a product for repair under warranty, provide us with the model name and serial number and a description of the problem. Any diagrams or data explaining the problem would also be appreciated.
  - If we replace the product with a new one, we won't provide you with a repair report.
- **In the following cases, customer will be charged repair fee regardless of warranty period.**
  - Failure of components which are out of scope of warranty stated in instruction manual.
  - Failure caused by usage of software, hardware or auxiliary equipment, which Yokogawa did not supply.
  - Failure due to improper or insufficient maintenance by user.
  - Failure due to modification, misuse or outside-of-specifications operation which Yokogawa does not authorize.
  - Failure due to power supply (voltage, frequency) being outside specifications or abnormal.
  - Failure caused by any usage out of scope of recommended usage.
  - Any damage from fire, earthquake, storms and floods, lightning, disturbances, riots, warfare, radiation and other natural changes.
- **Yokogawa does not warrant conformance with the specific application at the user site. Yokogawa will not bear direct/indirect responsibility for damage due to a specific application.**
- **Yokogawa will not bear responsibility when the user configures the product into systems or resells the product.**
- **Maintenance service and supplying repair parts will be covered for five years after the production ends. For repair for this product, please contact the nearest sales office described in this instruction manual.**

# Model ZR22S, ZR402G

## Separate type Explosion-proof Zirconia Oxygen Analyzer

IM 11M13A01-02E 15th Edition

## CONTENTS

◆	Introduction.....	i
◆	Safety Precautions .....	v
◆	CE marking products .....	vii
◆	After-Sales Warranty .....	viii
1.	Overview.....	1-1
1.1	< EXAxt ZR > System Configuration.....	1-1
1.1.1	System 1 .....	1-1
1.1.2	System 2 .....	1-2
1.2	< EXAxt ZR > System Components .....	1-3
1.2.1	System Components .....	1-3
1.2.2	Detectors and Accessories .....	1-3
2.	Specifications .....	2-1
2.1	General Specifications .....	2-1
2.2	Separate type Explosion-proof Detector and Related Equipment.....	2-3
2.2.1	ZR22S Separate type Explosion-proof Detector .....	2-3
2.2.2	ZO21R Probe Protector .....	2-9
2.3	Separate type Explosion-proof Detector for High Temperature and Related Equipment.....	2-10
2.3.1	ZR22S (0.15 m) Separate type Explosion-proof Detector for High Temperature .....	2-10
2.3.2	ZO21P High Temperature Probe Adapter .....	2-11
2.4	ZR402G Separate type Converter .....	2-13
2.4.1	Standard Specification.....	2-13
2.4.2	Functions.....	2-14
2.5	ZA8F Flow Setting Unit and ZR40H Automatic Calibration Unit.....	2-18
2.5.1	ZA8F Flow Setting Unit.....	2-18
2.5.2	ZR40H Automatic Calibration Unit.....	2-20
2.6	ZO21S Standard Gas Unit .....	2-22
2.7	Other Equipments.....	2-23
2.7.1	Ejector Assembly for High Temperature (E7046EC, E7046EN) .....	2-23
2.7.2	Stop Valve (L9852CB, G7016XH) .....	2-25
2.7.3	Check Valve (K9292DN, K9292DS) .....	2-25
2.7.4	Air Set.....	2-26
2.7.5	Cylinder Pressure Reducing Valve (G7013XF, G7014XF).....	2-27

	2.7.6	ZR22A Heater Assembly.....	2-28
<b>3.</b>		<b>Installation.....</b>	<b>3-1</b>
	<b>3.1</b>	<b>Installation of General-purpose Detector.....</b>	<b>3-2</b>
	3.1.1	Installation Location .....	3-2
	3.1.2	ATEX Flameproof Type.....	3-2
	3.1.3	FM Explosion-proof Type.....	3-3
	3.1.4	CSA Explosion-proof Type.....	3-4
	3.1.5	IECEX Flameproof Type.....	3-5
	3.1.6	Probe Insertion Hole .....	3-7
	3.1.7	Installation of the Detector .....	3-7
	3.1.8	Installation of Probe Protector (ZO21R) .....	3-8
	<b>3.2</b>	<b>Installation of High Temperature Detector (Model ZR22S-□-015).....</b>	<b>3-8</b>
	3.2.1	Installation Location .....	3-8
	3.2.2	Usage of High Temperature Probe Adapter (Model ZO21P).....	3-8
	3.2.3	Probe Insertion Hole .....	3-10
	3.2.4	Mounting of High Temperature Detector.....	3-11
	<b>3.3</b>	<b>Installation of ZR402G Converter.....</b>	<b>3-12</b>
	3.3.1	Installation Location .....	3-12
	3.3.2	Mounting of the Converter .....	3-12
	<b>3.4</b>	<b>Installation of ZA8F Flow Setting Unit.....</b>	<b>3-14</b>
	3.4.1	Installation Location .....	3-14
	3.4.2	Mounting of ZA8F Flow Setting Unit.....	3-14
	<b>3.5</b>	<b>Installation of ZR40H Automatic Calibration Unit .....</b>	<b>3-15</b>
	3.5.1	Installation Location .....	3-15
	3.5.2	Mounting of ZR40H Automatic Calibration Unit.....	3-15
	<b>3.6</b>	<b>Insulation Resistance Test.....</b>	<b>3-17</b>
<b>4.</b>		<b>Piping.....</b>	<b>4-1</b>
	<b>4.1</b>	<b>Piping for a System Using Flow Setting Unit for Manual Calibration .....</b>	<b>4-2</b>
	4.1.1	Parts Required for Piping in a System Using Flow Setting Units for Manual Calibration .....	4-3
	4.1.2	Piping for the Calibration Gas Inlet .....	4-4
	4.1.3	Piping for the Reference Gas Inlet.....	4-4
	4.1.4	Piping for the Reference Gas Outlet.....	4-4
	4.1.5	Piping to the High Temperature Probe Adapter .....	4-4
	<b>4.2</b>	<b>Piping for a System to Perform Automatic Calibration .....</b>	<b>4-6</b>
	4.2.1	Parts Required for Piping in a System to Perform Automatic Calibration .....	4-7
	4.2.2	Piping for the Calibration Gases .....	4-8
	4.2.3	Piping for the Reference Gas.....	4-8
	4.2.4	Piping to the High Temperature Probe Adapter .....	4-9
	4.2.5	Piping for Blow back.....	4-9
<b>5.</b>		<b>Wiring.....</b>	<b>5-1</b>
	<b>5.1</b>	<b>General.....</b>	<b>5-1</b>

---

5.1.1	Terminals for the External Wiring in the Converter .....	5-2
5.1.2	Wiring .....	5-3
5.1.3	Mounting of Cable Gland .....	5-4
<b>5.2</b>	<b>Wiring for Detector Output.....</b>	<b>5-5</b>
5.2.1	Cable Specifications .....	5-5
5.2.2	Connection to the Detector .....	5-6
5.2.3	Connection to the Converter .....	5-6
<b>5.3</b>	<b>Wiring for Power to Detector Heater.....</b>	<b>5-7</b>
5.3.1	Cable Specifications .....	5-7
5.3.2	Connection to Detector .....	5-7
5.3.3	Connection to Converter .....	5-8
<b>5.4</b>	<b>Wiring for Analog Output .....</b>	<b>5-9</b>
5.4.1	Cable Specifications .....	5-9
5.4.2	Wiring Procedure .....	5-9
<b>5.5</b>	<b>Power and Grounding Wiring.....</b>	<b>5-9</b>
5.5.1	Power Wiring.....	5-9
5.5.2	Grounding Wiring.....	5-10
<b>5.6</b>	<b>Contact Output Wiring.....</b>	<b>5-10</b>
5.6.1	Cable Specifications .....	5-10
5.6.2	Wiring Procedure .....	5-11
<b>5.7</b>	<b>Wiring for ZR40H Automatic Calibration Unit.....</b>	<b>5-11</b>
5.7.1	Cable Specifications .....	5-11
5.7.2	Wiring Procedure .....	5-12
<b>5.8</b>	<b>Contact Input Wiring.....</b>	<b>5-12</b>
5.8.1	Cable Specifications .....	5-12
5.8.2	Wiring Procedure .....	5-12
<b>6.</b>	<b>Components and Their Functions.....</b>	<b>6-1</b>
<b>6.1</b>	<b>ZR22S Detector .....</b>	<b>6-1</b>
6.1.1	General-purpose Explosion-proof Detector (except for ZR22S-□-015).....	6-1
6.1.2	High Temperature Detector (ZR22S-□-015).....	6-2
<b>6.2</b>	<b>ZR402G Converter .....</b>	<b>6-3</b>
<b>6.3</b>	<b>Touchpanel Switch Operations .....</b>	<b>6-4</b>
6.3.1	Basic Panel and Switch .....	6-4
6.3.2	Display Configuration (for Oxygen Analyzer) .....	6-5
6.3.3	Display Functions.....	6-6
6.3.4	Entering Numeric and Text Data.....	6-6
<b>6.4</b>	<b>ZA8F Flow Setting Unit, ZR40H Automatic Calibration Unit .....</b>	<b>6-8</b>
<b>7.</b>	<b>Startup .....</b>	<b>7-1</b>
7.1	Startup Procedure.....	7-1
7.2	Checking Piping and Wiring Connections.....	7-1
7.3	Checking Valve Setup.....	7-2
7.4	Supplying Power to the Converter.....	7-2

---

7.5	<b>Confirmation of Converter Type Setting</b> .....	7-3
7.6	<b>Confirmation of Detector Type Setting</b> .....	7-4
7.7	<b>Selection of Sample Gas</b> .....	7-4
7.8	<b>Output Range Setting</b> .....	7-4
7.9	<b>Setting Display Item</b> .....	7-5
7.10	<b>Checking Current Loop</b> .....	7-6
7.11	<b>Checking Contact I/O</b> .....	7-7
	7.11.1 Checking Contact Outputs.....	7-7
	7.11.2 Checking Calibration Contact Outputs .....	7-8
	7.11.3 Checking Contact Inputs.....	7-8
7.12	<b>Calibration</b> .....	7-9
	7.12.1 Calibration Setup .....	7-9
	7.12.2 Manual Calibration .....	7-10
<b>8.</b>	<b>Detailed Data Setting</b> .....	<b>8-1</b>
<b>8.1</b>	<b>Current Output Setting</b> .....	<b>8-1</b>
	8.1.1 Setting Minimum Current (4 mA) and Maximum Current (20 mA) ....	8-1
	8.1.2 Input Ranges.....	8-1
	8.1.3 Setting Output Smoothing Coefficient .....	8-2
	8.1.4 Selection of Output Mode .....	8-2
	8.1.5 Default Values .....	8-2
<b>8.2</b>	<b>Output Hold Setting</b> .....	<b>8-3</b>
	8.2.1 Definition of Equipment Status .....	8-3
	8.2.2 Preference Order of Output Hold Value.....	8-4
	8.2.3 Output Hold Procedure .....	8-4
	8.2.4 Default Values .....	8-5
<b>8.3</b>	<b>Oxygen Concentration Alarms Setting</b> .....	<b>8-6</b>
	8.3.1 Setting the Alarm Values .....	8-6
	8.3.2 Alarm Output Actions .....	8-6
	8.3.3 Alarm Setting Procedure.....	8-7
	8.3.4 Default Values .....	8-8
<b>8.4</b>	<b>Contact Output Setting</b> .....	<b>8-8</b>
	8.4.1 Contact Output .....	8-8
	8.4.2 Setting Procedure .....	8-9
	8.4.3 Default Values .....	8-11
<b>8.5</b>	<b>Contact Input Setting</b> .....	<b>8-12</b>
	8.5.1 Contact Input Functions .....	8-12
	8.5.2 Setting Procedure .....	8-13
	8.5.3 Default Values .....	8-13
<b>8.6</b>	<b>Other Settings</b> .....	<b>8-14</b>
	8.6.1 Setting the Date-and-Time.....	8-14
	8.6.2 Setting Periods over which Average Values Are Calculated and Periods over which Maximum and Minimum Values Are Monitored.....	8-14

8.6.3	Setting Fuels .....	8-15
8.6.4	Setting Purging .....	8-20
8.6.5	Setting Passwords .....	8-21
<b>9.</b>	<b>Calibration .....</b>	<b>9-1</b>
<b>9.1</b>	<b>Calibration Briefs .....</b>	<b>9-1</b>
9.1.1	Principle of Measurement .....	9-1
9.1.2	Calibration Gas .....	9-2
9.1.3	Compensation .....	9-3
9.1.4	Characteristic Data from a Sensor Measured During Calibration .....	9-4
<b>9.2</b>	<b>Calibration Procedures .....</b>	<b>9-5</b>
9.2.1	Calibration Setting .....	9-5
9.2.2	Default Values .....	9-8
9.2.3	Calibration .....	9-9
<b>10.</b>	<b>Other Functions .....</b>	<b>10-1</b>
<b>10.1</b>	<b>Detailed-data Display .....</b>	<b>10-1</b>
10.1.1	Cell Voltage .....	10-1
10.1.2	Thermocouple Voltage .....	10-2
10.1.3	Cold Junction Resistance (C.J. Voltage) .....	10-2
10.1.4	Cell's Internal Resistance .....	10-2
10.1.5	Software Revision .....	10-2
10.1.6	Span gas and Zero gas Correction Ratios .....	10-2
10.1.7	Cell Response Time .....	10-3
10.1.8	Robustness of a Cell .....	10-3
10.1.9	Cell Temperature .....	10-3
10.1.10	C. J. Temperature .....	10-4
10.1.11	Maximum Oxygen Concentration .....	10-4
10.1.12	Minimum Oxygen Concentration .....	10-4
10.1.13	Average Oxygen Concentration .....	10-4
10.1.14	Heater On-Time Ratio .....	10-4
10.1.15	Time .....	10-4
10.1.16	History of Calibration Time .....	10-4
10.1.17	Power Supply Voltage .....	10-4
10.1.18	Power Frequency .....	10-4
<b>10.2</b>	<b>Trend Graph .....</b>	<b>10-5</b>
10.2.1	Setting Display Items .....	10-5
10.2.2	Sampling Interval .....	10-5
10.2.3	Setting Upper and Lower Limit Values on Graph .....	10-6
10.2.4	Default Setting .....	10-6
<b>10.3</b>	<b>Other Display-related Functions .....</b>	<b>10-7</b>
10.3.1	Auto-Return Time .....	10-7
10.3.2	Entering Tag Name .....	10-7
10.3.3	Language Selection .....	10-7

<b>10.4</b>	<b>Blow Back</b> .....	<b>10-8</b>
10.4.1	Mode of Blow back.....	10-8
10.4.2	Operation of Blow back.....	10-8
10.4.3	Setting Output Hold Time and Blow back Time .....	10-9
10.4.4	Setting Interval, Start Date, and Start Time .....	10-9
10.4.5	Default Setting.....	10-10
<b>10.5</b>	<b>Parameter Initialization</b> .....	<b>10-10</b>
<b>10.6</b>	<b>Reset</b> .....	<b>10-13</b>
<b>10.7</b>	<b>Handling of the ZO21S Standard Gas Unit</b> .....	<b>10-14</b>
10.7.1	Standard Gas Unit Component Identification .....	10-14
10.7.2	Installing Gas Cylinders .....	10-15
10.7.3	Calibration Gas Flow.....	10-15
<b>10.8</b>	<b>Methods of Operating Valves in the ZA8F Flow Setting Unit</b> .....	<b>10-18</b>
10.8.1	Preparation Before Calibration .....	10-18
10.8.2	Operating the Span Gas Flow Setting Valve .....	10-18
10.8.3	Operating the Zero Gas Flow Setting Valve .....	10-18
10.8.4	Operation After Calibration .....	10-19
<b>11.</b>	<b>Inspection and Maintenance</b> .....	<b>11-1</b>
<b>11.1</b>	<b>Inspection and Maintenance of the Detector</b> .....	<b>11-2</b>
11.1.1	Cleaning the Calibration Gas Tube.....	11-2
11.1.2	Replacing the Sensor Assembly.....	11-2
11.1.3	Replacement of the Heater Unit (Assembly) .....	11-5
11.1.4	Replacement of Flame Arrestor Assembly .....	11-8
11.1.5	Replacement of O-ring.....	11-8
11.1.6	Cleaning the High Temperature Probe Adapter.....	11-9
11.1.7	Stopping and Re-starting Operation .....	11-9
<b>11.2</b>	<b>Inspection and Maintenance of the Converter</b> .....	<b>11-10</b>
11.2.1	Replacing Fuses .....	11-10
11.2.2	Cleaning .....	11-11
11.2.3	Adjust LCD screen contrast .....	11-11
<b>11.3</b>	<b>Replacing Flowmeter in ZR40H Automatic Calibration Unit</b> .....	<b>11-12</b>
<b>12.</b>	<b>Troubleshooting</b> .....	<b>12-1</b>
<b>12.1</b>	<b>Displays and Remedies When Errors Occur</b> .....	<b>12-1</b>
12.1.1	Error Types.....	12-1
12.1.2	Remedies When an Error Occurs.....	12-2
<b>12.2</b>	<b>Displays and Remedies When Alarms are Generated</b> .....	<b>12-5</b>
12.2.1	Alarm Types .....	12-5
12.2.2	Remedies When Alarms are Generated.....	12-6
<b>12.3</b>	<b>Countermeasures When Measured Value Shows Error</b> .....	<b>12-11</b>
12.3.1	Measured Value Higher Than True Value.....	12-11
12.3.2	Measured Value Lower Than True Value .....	12-12
12.3.3	Measurements Sometimes Show Abnormal Values .....	12-12

---

<b>Customer Maintenance Parts List.....</b>	<b>CMPL 11M13A01-02E</b>
<b>Customer Maintenance Parts List.....</b>	<b>CMPL 11M12C01-01E</b>
<b>Customer Maintenance Parts List.....</b>	<b>CMPL 11M12A01-11E</b>
<b>Customer Maintenance Parts List.....</b>	<b>CMPL 11M03B01-10E</b>
<b>Customer Maintenance Parts List.....</b>	<b>CMPL 11M03B01-05E</b>
<b>Customer Maintenance Parts List.....</b>	<b>CMPL 11M3D1-01E</b>
<b>Revision Information .....</b>	<b>i</b>





# 1. Overview

The EXAxtZR Separate type Explosion-proof Zirconia Oxygen Analyzer is used to monitor and control the oxygen concentration in combustion gases, in boilers and industrial furnaces, for wide application in industries which consume considerable energy—such as steel, electric power, oil and petrochemical, ceramics, paper and pulp, food, or textiles, as well as incinerators and medium/small boilers. It can help conserve energy in these industries. The EXAxtZR also contributes to preservation of the earth’s environment in preventing global warming and air pollution by controlling complete combustion to reduce CO<sub>2</sub>, SO<sub>x</sub> and NO<sub>x</sub>.

ZR22S Separate type Explosion-proof Detector uses a high-reliability Zirconia sensor, and its heater assembly can be replaced on site. The detector is mounted, for example, on the wall of a flue and can measure the gases directly.

For use in combustion gases at temperatures up to 1400°C, choose the general-purpose 0.15 m long detector, which is combined with ZO21P, the high temperature probe protector. The converter is equipped with an LCD touch screen which has various setting displays, a calibration display, oxygen concentration trend display, with easier operation and improvement of display functions. The converter is equipped with various standard functions such as measurement and calculation as well as maintenance functions including self-test. Analyzer calibration can also be fully automated — and ZR40H, an automatic calibration unit, is available. Choose the detector version which best suits your needs so that an optimal combustion control system can be obtained.

Some examples of typical system configurations are illustrated below:

## 1.1 < EXAxt ZR > System Configuration

The system configuration should be determined by the conditions; e.g. whether calibration is to be automated, and whether flammable gas is present and requires safety precautions. The system configuration can be classified into three basic patterns as follows:

### 1.1.1 System 1

This system is for monitoring and controlling oxygen concentration in the combustion gases of a large-size boiler or heating furnace. Clean (dry) air (21%O<sub>2</sub>) is used as the reference gas and the span gas for calibration. Zero gas is fed in from a cylinder during calibration. The gas flow is controlled by the ZA8F flow setting unit (for manual valve operation).

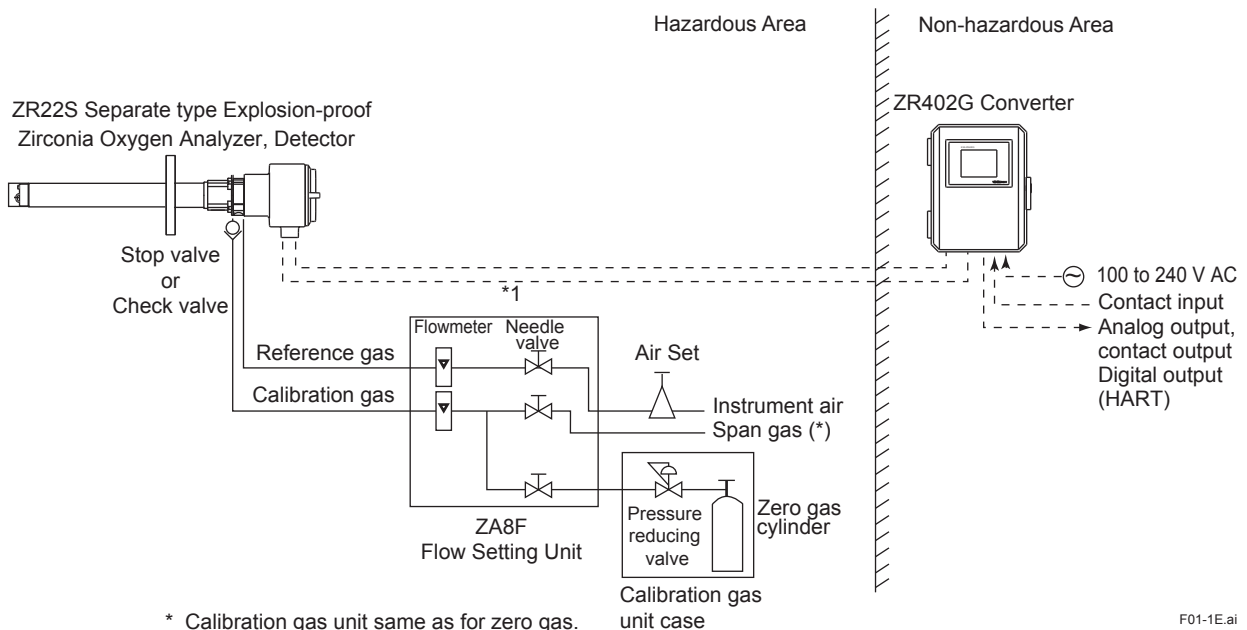

Figure 1.1 System configuration 1

F01-1E.ai

### 1.1.2 System 2

This example, System 2, represents typical applications in large boilers and heating furnaces, where there is a need to monitor and control oxygen concentration. The reference gas and calibration-time span gas are (clean, dry) instrument air. Zero gas is supplied from a gas cylinder.

System 2 uses the ZR40H automatic calibration unit, with auto-switching of the calibration gas. A “combustible gas detected” contact input turns off power to the heater. There’s also contact output from the converter that can be used to operate a purge gas valve to supply air to the sensor.

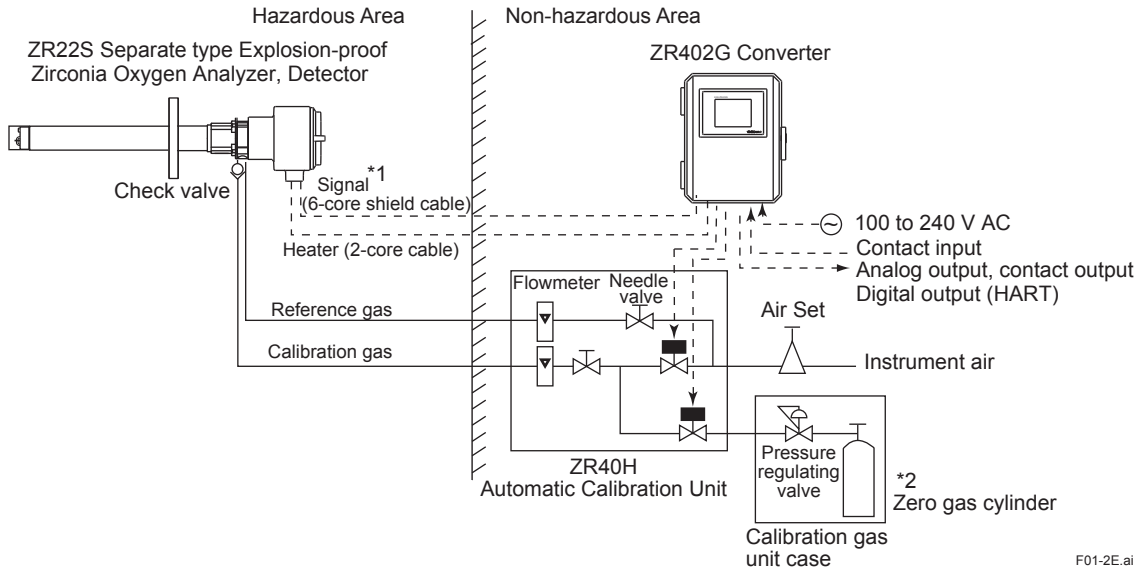

\*1: Shield cable; Use shielded signal cables, and connect the shield to the FG terminal of the converter.  
\*2: When a zirconia oxygen analyzer is used, 100% N<sub>2</sub> gas cannot be used as the zero gas. Use approximately 1% of O<sub>2</sub> gas (N<sub>2</sub>-based).

Figure 1.2 System configuration 2

F01-2E.ai

# 1.2 < EXAxt ZR > System Components

## 1.2.1 System Components

System Components	Separate type	
	System configuration	
	System 1	System 2
ZR22S Separate type Explosion-proof Zirconia Oxygen Analyzers, Detector	●	●
ZR402G Separate type Zirconia Oxygen Analyzer, Converter	●	●
ZO21P High Temperature Probe Adapter for separate type Zirconia Oxygen Analyzer	○	○
E7046EC, E7046EN Ejector Assembly for High Temperature	○	○
ZO21R Probe Protector for Zirconia Oxygen Analyzers	○	○
ZO21S Standard Gas Unit		
ZA8F Flow Setting Unit for manual calibration	●	
ZR40H Automatic Calibration Unit for Separate type Analyzer		●
L9852CB, G7016XH Stop Valve for Calibration gas line	(●)	
K9292DN, K9292DS Check Valve for Calibration gas line	(●)	●
G7003XF/K9473XK, G7004XF/K9473XG Air Set	●	●
G7013XF, G7014XF Pressure Reducing Valve for Gas Cylinder	●	●
ZR22A, Heater Assembly (Spare Parts for ZR22S)	○	○

- : Items required for the above system example
- : To be selected depending on each application. For details, refer to corresponding chapter.
- (●) : Select either

## 1.2.2 Detectors and Accessories

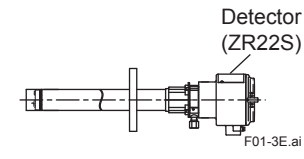
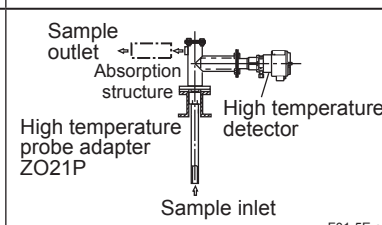
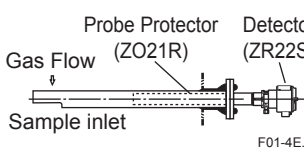
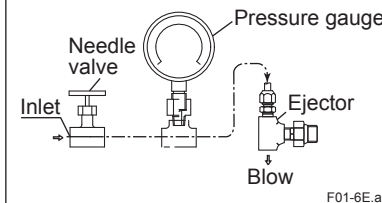
Sample gas temperature 0 to 700°C				Sample gas temperature 700 to 1400°C	
Mounting	Insertion length	General-purpose detector	Application	High temperature detector	Application
Horizontal to vertical	2 m or less	 <p>Detector (ZR22S) F01-3E.ai</p>	Boiler Heating furnace	 <p>Sample outlet Absorption structure High temperature probe adapter ZO21P High temperature detector Sample inlet F01-5E.ai</p>	Heating furnace
		 <p>Probe Protector (ZO21R) Detector (ZR22S) Gas Flow Sample inlet F01-4E.ai</p>	For pulverized coal boiler with gas flow velocity 10 m/sec or more	<p>Probe material and Temperature: SUS310S; 800°C, SiC; 1400°C Mounting: Vertical downwards Insertion length: 0.5, 0.6, 0.7, 0.8, 0.9, 1.0, 1.5 m When duct pressure is atmospheric or negative, attach ejector assembly.</p>  <p>Inlet Needle valve Pressure gauge Ejector Blow F01-6E.ai</p>	Ejector assembly for high temperature (E7046EC, E7046EN)

---

Blank Page

## 2. Specifications

This chapter describes the specifications for the following:

ZR22S	Separate type explosion-proof detector (See Subsection 2.2.1)
ZO21R	Probe protector (See Subsection 2.2.2)
ZR22S (0.15 m)	Separate type explosion-proof detector for high temperature (See Subsection 2.3.1)
ZO21P	High temperature probe adapter (See Subsection 2.3.2)
ZR402G	Separate type converter (See Section 2.4)
ZA8F	Flow setting unit (See Subsection 2.5.1)
ZR40H	Automatic calibration unit (See Subsection 2.5.2)
ZO21S	Standard gas unit (See Section 2.6)
	Other Equipments (See Section 2.7)

### CAUTION

Requirements for explosion-proof use:

The ZR22S is connected to a ZR402G or AV550G\*1 that is mounted in a non-hazardous area. The ambient temperature is in the range -20 to + 60°C. The surface temperature of the ZR22S is not over the temperature class T2 (300°C)\*2.

\*1: Refer to IM 11M12D01-01E

\*2: The terminal box temperature does not exceed 150°C.

Oxygen concentration of sample/reference/calibration gas shall not exceed that found in normal air, typically 21 vol%.

## 2.1 General Specifications

### Standard Specifications

Measured Object:	Oxygen concentration in combustion exhaust gas and mixed gas (excluding inflammable gases. May not be applicable corrosive gas such as ammonia and chlorine is present — Contact with YOKOGAWA and its agency.)
Measurement System:	Zirconia system
Measurement range:	0.01 to 100 vol%O <sub>2</sub>
Output Signal:	4 to 20 mA DC (maximum load resistance 550 Ω)
Setting Range:	Any setting in the range of 0 to 5 through 0 to 100 vol%O <sub>2</sub> (in 1 vol%O <sub>2</sub> ), or partial range
Digital Communication	(HART): 250 to 550 Ω, depending on number of field devices connected to the loop (multi-drop mode).

Note: HART is a registered trademark of the HART Communication Foundation.

Display Range:	0 to 100 vol%O <sub>2</sub>
Warm-up Time:	Approx. 20 min.
Repeatability:	±0.5% Maximum value of set range; Range from 0 to 5 vol%O <sub>2</sub> or more and less than 0 to 25 vol%O <sub>2</sub> ±1% Maximum value of set range; Range from 0 to 25 vol%O <sub>2</sub> or more and up to 0 to 100 vol%O <sub>2</sub>

Linearity: (Excluding standard gas tolerance)  
(Use oxygen of known concentration (within the measuring range) as the zero and span calibration gases.)  
±1% Maximum value of set range; Range from 0 to 5 vol%O<sub>2</sub> to 0 to 25 vol%O<sub>2</sub>. (Sample gas pressure: within ±4.9 kPa)  
±3% Maximum value of set range; Range from 0 to 25 vol%O<sub>2</sub> or more and less than 0 to 50 vol%O<sub>2</sub>. (Sample gas pressure: within ±0.49 kPa)  
±5% Maximum value of set range; Range from 0 to 50 vol%O<sub>2</sub> to 0 to 100vol%O<sub>2</sub>. (Sample gas pressure: within ±0.49 kPa)

Drift: (Excluding the first two weeks in use)  
Both zero and span ±2% Maximum value of range setting/month

Response Time : Response of 90% within 5 seconds. (Measured after gas is introduced from calibration gas inlet and analog output starts changing.)

Safety, EMC, and RoHS conformity standards of ZR22S and ZR402G

Installation altitude based on IEC 61010-1: 2000 m or less

Category based on IEC 61010-1: II (Note)

Pollution degree based on IEC 61010-1: 2 (Note)

Not Installation category, called over-voltage category, specifies impulse withstand voltage. Category II is for electrical equipment.

Pollution degree indicates the degree of existence of solid, liquid, gas or other inclusions which may reduce dielectric strength. Degree 2 is the normal indoor environment.

Safety: Conforms to EN 61010-1, EN61010-2-030,  
CAN/CSA-C22.2 No. 61010-1 certified,  
UL Std. No. 61010-1 certified

EMC: Conforms to EN 61326-1\*, Class A, Table 2,  
EN 61326-2-3, EN 61000-3-2, EN IEC 61000-3-2

\*: Influence of immunity environment (Criteria A): ±20% of F. S.

EMC Regulatory Arrangement in Australia and New Zealand (RCM)  
EN61326-1 Class A

Note: Korea Electromagnetic Conformity Standard  
This instrument is a Class A product, and it is designed for use in the industrial environment. Please use this instrument in the industrial environment only.

RoHS: EN IEC 63000

Information of the WEEE Directive

This product is purposely designed to be used in a large scale fixed installations only and, therefore, is out of scope of the WEEE Directive. The WEEE Directive does not apply. The WEEE Directive is only valid in the EU.

## 2.2 Separate type Explosion-proof Detector and Related Equipment

Separate type Explosion-proof detector ZR22S can be used in combination with the probe protector ZO21R (see Subsection 2.2.2).

### 2.2.1 ZR22S Separate type Explosion-proof Detector

Flameproof Type

ATEX Flameproof: ZR22S-A

Applicable Standard:

EN IEC 60079-0: 2018, EN 60079-1: 2014  
EN 60079-31: 2014

Certificate Number: KEMA 04ATEX2156 X

Type of protection: Ex db IIB+H<sub>2</sub> T2 Gb, Ex tb IIIC T300°C Db

Equipment Group: II







Category: 2GD

Temperature class for Ex "db": T2

The maximum surface temperature for Ex "tb": T300°C

Degree of protection of enclosure: IP66

#### NAME PLATE

<b>ZIRCONIA DETECTOR</b>		 <b>WARNING</b> · DO NOT OPEN WHEN AN EXPLOSIVE GAS ATMOSPHERE IS PRESENT · POTENTIAL ELECTROSTATIC CHARGING HAZARD - READ USER'S MANUAL (IM 11M13A01-02) · FOR INSTALLATION AND SAFE USE, READ IM 11M13A01-02
<b>MODEL</b>	ZR22S	
<b>SUFFIX</b>		 <b>HIGH TEMPERATURE</b> · USE AT LEAST 150°C HEAT RESISTANT CABLES & CABLE GLANDS IP66 Um=240VAC:100-240VAC
<b>STYLE</b>		
<b>AMB. TEMP</b>	-20 TO 60°C	 II2G <input type="checkbox"/> Ex db IIB+H <sub>2</sub> T2 Gb  II2D <input type="checkbox"/> Ex tb IIIC T300°C Db
<b>NO.</b>		
 <b>0344</b>		No. KEMA 04ATEX2156 X YOKOGAWA ◆ Made in Japan
 II2G <input type="checkbox"/> Ex db IIB+H <sub>2</sub> T2 Gb  II2D <input type="checkbox"/> Ex tb IIIC T300°C Db		
YOKOGAWA ◆ Made in Japan		YOKOGAWA Electric Corporation Tokyo 180-8750 JAPAN

MODEL : Specified model code

SUFFIX : Specified suffix code

STYLE : Style code

AMB. TEMP : Ambient temperature

NO. : Serial No. and year of production\*1

Yokogawa Electric Corporation : The manufacturer name

Tokyo 180-8750 JAPAN : The manufacturer address\*2

The country of origin

\*1: The third to seventh figure from the last shows the year of production.  
e.g. 27D327560 2005.02

↑ The year of production

\*2: "180-8750" is a zip code which represents the following address.  
2-9-32 Nakacho, Musashino-shi, Tokyo Japan

Note: "□" is the checkbox for selecting type of protection.

Apply a permanent mark in the checkbox of selected the type of protection.

Once the type of protection is selected, it shall not be changed.

FM Explosion-proof: ZR22S-B

Applicable Standard: FM3600 2011, FM3615 2006, FM3810 2005,  
ANSI/NEMA 250 1991

Type of protection: Explosion-proof for Class I, Division 1, Groups B, C and D

Dust-ignitionproof for Class II/III, Division 1, Groups E, F and G

Enclosure Rating: NEMA 4X

Temperature Class: T2

CSA Explosion-proof: ZR22S-C



Applicable Standard: C22.2 No.0-M1991, C22.2 No.0.4-04,  
C22.2 No.0.5-1982, C22.2 No.25-1966,  
C22.2 No.30-M1986, C22.2 No.94-M91,  
C22.2-No.61010-1-04

Certificate Number: 1649642

Type of protection: Explosion-proof for Class I, Division 1, Groups B, C and D

Dust-ignitionproof for Class II/III, Division 1, Groups E, F and G

Enclosure: Type 4X

Temperature Class: T2

IECEX Flameproof: ZR22S-D

Applicable Standard: IEC 60079-0: 2017, IEC 60079-1: 2014, IEC 60079-31: 2013

Certificate Number: IECEX KEM 06.0006X

Type of protection: Ex db IIB+H<sub>2</sub> T2 Gb, Ex tb IIIC T300°C Db

Temperature class for Ex “db”: T2

The maximum surface temperature for Ex “tb”: T300°C

Degree of protection of enclosure: IP66

**NAME PLATE**

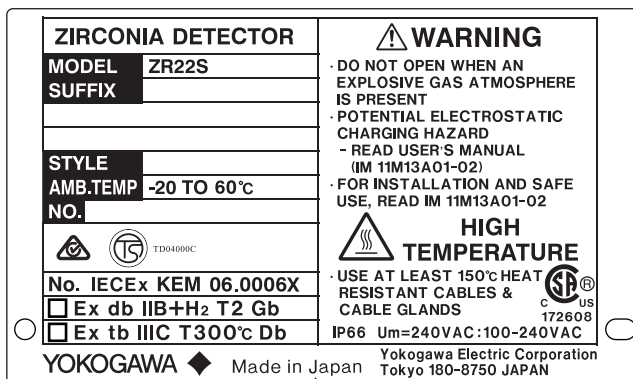

MODEL : Specified model code  
SUFFIX : Specified suffix code  
STYLE : Style code  
AMB. TEMP : Ambient temperature  
NO. : Serial No. and year of production\*1  
Yokogawa Electric Corporation : The manufacturer name  
Tokyo 180-8750 JAPAN : The manufacturer address\*2

The country of origin.

\*1: The third to seventh figure from the last shows the year of production.  
e.g. 27D327560 2005.02

\*2: "180-8750" is a zip code which represents the following address.  
2-9-32 Nakacho, Musashino-shi, Tokyo Japan

Note: “” is the checkbox for selecting type of protection.

Apply a permanent mark in the checkbox of selected the type of protection.

Once the type of protection is selected, it shall not be changed.

EAC Flameproof : ZR22S-Q / ZR22S-R

Applicable Standard: TP TC 012/2011

Certificate Number: RU C-JP.AA87.B.00040/18

Type of Protection: 1Ex db IIB+H<sub>2</sub> T2 Gb X, Ex tb IIIC T300°C Db X

Temperature class for Ex “db”: T2

The maximum surface temperature for Ex “tb”: T300°C

Degree of Protection of Enclosure: IP66

KOSHA Explosion-proof: ZR22S-K

Applicable Standard: Notice of Ministry of Labor No. 2016-54

Certificate Number: 18-AV4BO-0061X

Type of protection:	Ex d IIB+H <sub>2</sub> T2
Temperature class for Ex "d":	T2
Degree of protection of enclosure:	IP66
Sample Gas Temperature:	0 to 700°C (Probe only) It is necessary to mount the cell using Inconel cell-bolts when the temperature is greater than 600°C or greater. 700 to 1400°C (with High Temperature Probe Adapter) For high temperature sample gas, apply 0.15 m length probe and High Temperature Probe Adapter ZO21P.
Sample Gas Pressure:	-5 to +5 kPa For 0.15 m probe, -0.5 to +5 kPa. No pressure fluctuation in the furnace should be allowed.
Oxygen concentration of sample gas:	For explosion-proof use, not more than that found in normal air, typically 21 vol%
Probe Length:	0.15, 0.4, 0.7, 1.0, 1.5, 2.0 m
Probe Material:	316 SS (JIS)
Ambient Temperature:	-20 to +60°C (-20 to +150°C on the terminal box surface)
Reference Gas System:	Instrument Air
Instrument Air System:	
Pressure;	50 kPa + the pressure inside the furnace (It is recommended to use air which has been dehumidified by cooling to dew point -20°C or less, and dust or oil mist are removed.)
Consumption;	Approx. 1 NL/min
Oxygen concentration of calibration gas:	For explosion-proof use, not more than that found in normal air, typically 21 vol%
Wetted Material:	316L SS (JIS), Zirconia, 304 SS (JIS) or ASTM grade 304 (flange), Hastelloy B, (Inconel 600, 601)
Construction:	Heater and thermocouple replaceable construction. Equivalent to NEMA 4X/IP66 (Achieved when pipes are installed at calibration gas and reference gas inlets and pipe is installed so that reference gas can be exhausted to clean atmosphere. Excluding probe top. And achieved when the cable entry is completely sealed with a cable gland.)
Terminal Box Case:	Material; Aluminum alloy
Terminal Box Paint Color:	Case; Mint green (Munsell 5.6BG3.3/2.9) Cover; Mint green (Munsell 5.6BG3.3/2.9)
Finish:	Polyurethane corrosion-resistant coating
Gas Connection:	Rc1/4 or 1/4 FNPT
Wiring Connection:	
ATEX;	M20 by 1.5 mm or 1/2 NPT select one type (2 pieces)
FM;	1/2 NPT (2 pieces)
CSA;	1/2 NPT (2 pieces)
IECEX;	M20 by 1.5 mm or 1/2 NPT select one type (2 pieces)
Installation:	Flange mounting
Probe Mounting Angle:	Horizontal to vertically downward.
Weight:	Insertion length of 0.4 m: Approx. 13kg (ANSI 150 4) Insertion length of 0.7 m: Approx. 14 kg (ANSI 150 4) Insertion length of 1.0 m: Approx. 15 kg (ANSI 150 4) Insertion length of 1.5 m: Approx. 17 kg (ANSI 150 4) Insertion length of 2.0 m: Approx. 19 kg (ANSI 150 4)
Available Converter:	ZR402G, AV550G

**! CAUTION**

The ZR22S must be used in conjunction with a ZR402G or AV550G. If used with a converter other than a ZR402G or AV550G, the ZR22S does not operate as an explosion-proof equipment.

● **Model and Codes**

Model	Suffix code	Option code	Description
ZR22S	-----	-----	Separate type Explosion-proof Zirconia Oxygen Analyzer, Detector
Explosion-proof Approval (*12)	-A	-----	ATEX certified flameproof (*11)
	-B	-----	FM certified explosion-proof
	-C	-----	CSA certified explosion-proof
	-D	-----	IECEX certified flameproof (*11)(*14)
	-Q	-----	EAC with PA certified explosion-proof (*13)
	-R	-----	EAC certified explosion-proof (*13)
	-K	-----	KOSHA certified explosion-proof
Length	-015	-----	0.15 m (for high temperature use) (*1)
	-040	-----	0.4 m
	-070	-----	0.7 m
	-100	-----	1.0 m
	-150	-----	1.5 m
	-200	-----	2.0 m
Wetted material	-S	-----	Stainless steel
	-C	-----	Stainless steel with Inconel calibration gas tube (*7)
Flange (*2)	-A	-----	ANSI Class 150 2 RF (*10)
	-B	-----	ANSI Class 150 3 RF
	-C	-----	ANSI Class 150 4 RF (*10)
	-E	-----	DIN PN10 DN50 A
	-F	-----	DIN PN10 DN80 A
	-G	-----	DIN PN10 DN100 A
	-K	-----	JIS 5K 65 FF
	-L	-----	JIS 10K 65 FF
	-M	-----	JIS 10K 80 FF
	-P	-----	JIS 10K 100 FF
	-Q	-----	JIS 5K 32 FF (for high temperature use) (*3)
	-R	-----	JPI Class 150 4 RF
	-S	-----	JPI Class 150 3 RF
	-W	-----	Westinghouse
Reference gas	-E	-----	External connection (Instrument air) (*8)
Gas thread	-R	-----	Rc1/4
	-T	-----	1/4 NPT (Female)
Connection box thread	-M	-----	M20 x1.5 mm
	-T	-----	1/2 NPT (*9)
Instruction manual	-E	-----	English
	-K	-----	Korea (*15)
—	-A	-----	Always -A
Options	/C	-----	Inconel bolt (*4)
	/CV	-----	Check valve (*5)
	/SV	-----	Stop valve (*5)
	/SCT	-----	Stainless steel tag plate (*6)
	/PT	-----	Printed tag plate (*6)

- \*1 Used with the ZO21P High Temperature Probe Adapter. Select flange (-Q).
- \*2 The thickness of the flange depends on its dimensions\*3 The thickness of the flange depends on its dimensions.
- \*3 The flange thickness does not conform to JIS specification.
- \*4 Inconel probe bolts and U shape pipe are used. Use this option for high temperature use (ranging from 600 to 700°C).
- \*5 Specify either /CV or /SV option code.
- \*6 Specify either /SCT or /PT option code.
- \*7 Recommended if sample gas contains corrosive gas like chlorine.
- \*8 Piping for reference gas must be installed to supply reference gas constantly at a specified flow rate.
- \*9 When selecting code -B (FM certified explosion-proof) or -C (CSA certified explosion-proof), select code -T (1/2 NPT).
- \*10 Confirm inside diameter of pipe attached to customer's flange in case that -A or -E is selected.
- \*11 The cable entry devices (cable glands etc.) and blind plugs shall be in type of protection Ex "db" or Ex "tb", suitable for the conditions of use and correctly installed. They shall provide a degree of ingress protection of at least IP66.
- \*12 When using ZR22S as CE marking compliance product, select -A (ATEX certified flameproof).
- \*13 "-Q" is the explosion-proof type of EAC with Pattern Approval for Russia. "-R" is the explosion-proof type of EAC for Kazakhstan and Belarus.
- \*14 Product registration is done by Yokogawa Taiwan Corporation as an importer in Taiwan.
- \*15 When selecting code -K (KOSHA certified explosion-proof).

● Standard Accessory

Item	Parts No.	Q'ty	Description
Allen wrench	L9827AB	1	For lock screw

■ External Dimensions

● ZR22S Separate type Explosion-proof Zirconia Oxygen Analyzer, Detectors

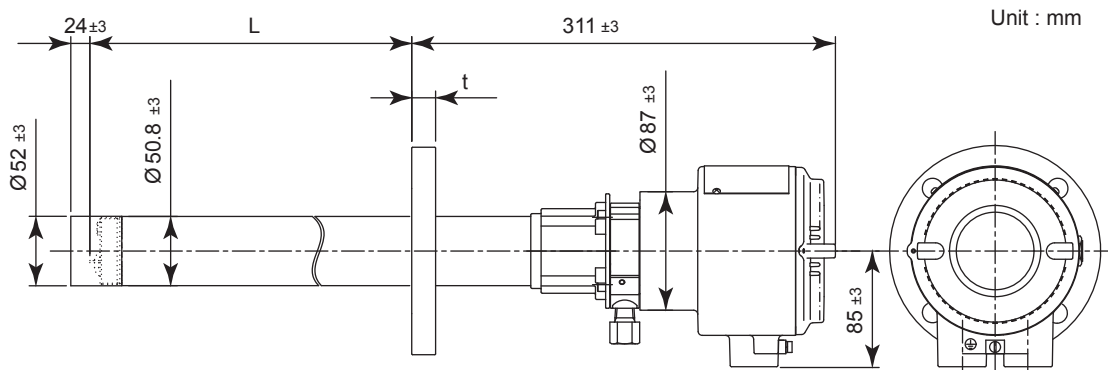

L (m)	tolerance (mm)
0.15	±4
0.4	±5
0.7	±7
1.0	±8
1.5	±10
2.0	±12

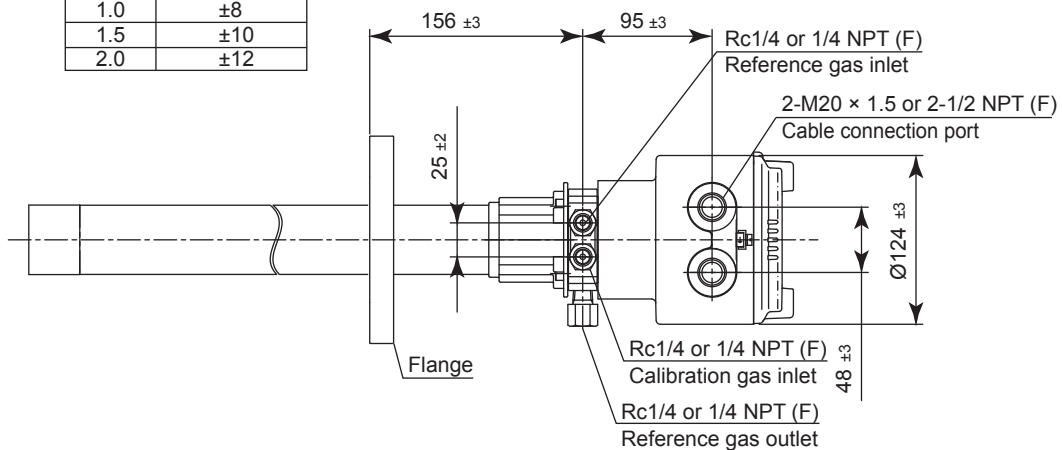

Flange	A	B	n	C	t
ANSI Class 150 2 RF	152.4	120.6	4	19	19
ANSI Class 150 3 RF	190.5	152.4	4	19	24
ANSI Class 150 4 RF	228.6	190.5	8	19	24
DIN PN10 DN50 A	165	125	4	18	18
DIN PN10 DN80 A	200	160	8	18	20
DIN PN10 DN100 A	220	180	8	18	20
JIS 5K 65 FF	155	130	4	15	14
JIS 10K 65 FF	175	140	4	19	18
JIS 10K 80 FF	185	150	8	19	18
JIS 10K 100 FF	210	175	8	19	18
JIS 5K 32 FF	115	90	4	15	5
JPI Class 150 4 RF	229	190.5	8	19	24
JPI Class 150 3 RF	190	152.4	4	19	24
Westinghouse	155	127	4	11.5	14

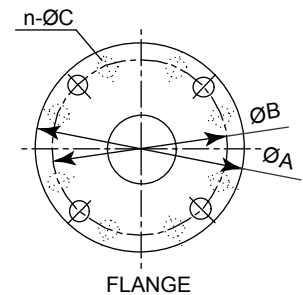

F02-3E.ai

● Check Valve (option code /CV), Stop valve (option code /SV) -specified Calibration gas inlet

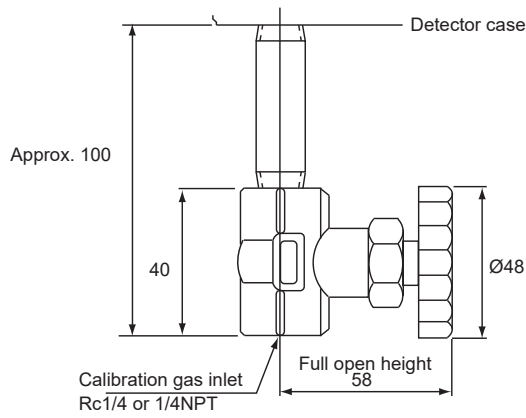

with Stop Valve (option: /SV)

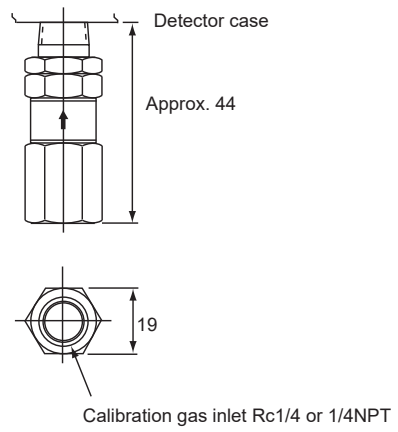

with Check Valve (option: /CV)

### 2.2.2 ZO21R Probe Protector

Used when sample gas flow velocity is approx. 10 m/sec or more and dust particles wears the detector in cases such as pulverized coal boiler or fluidized bed furnace (or burner) to protect the detector from wearing by dust particles.

- Insertion Length: 1.05, 1.55, 2.05 m.
- Flange: JIS 5K 65A FF equivalent. ANSI Class 150 4 FF (without serration) equivalent. However, flange thickness is different.
- Material: 316 SS (JIS), 304 SS (JIS) or ASTM grade 304 (Flange)
- Weight: 1.05 m; Approx. 6/10 kg (JIS/ANSI),  
1.55 m; Approx. 9/13 kg (JIS/ANSI),  
2.05 m; Approx. 12/16 kg (JIS/ANSI)
- Installation: Bolts, nuts, and washers are provided for detector, probe protector and process-side flange.

#### ● Model and Codes

Model	Suffix code	Option code	Description
ZO21R	-L	-----	Probe Protector(0 to 700°C)
Insertion length	-100	-----	1.05 m (3.5 ft)
	-150	-----	1.55 m (5.1 ft)
	-200	-----	2.05 m (6.8 ft)
Flange (*1)	-J	-----	JIS 5K 65 FF
	-A	-----	ANSI Class 150 4 FF
Style code	*B	-----	Style B

\*1 Thickness of flange depends on dimensions of flange.

#### ● External Dimension

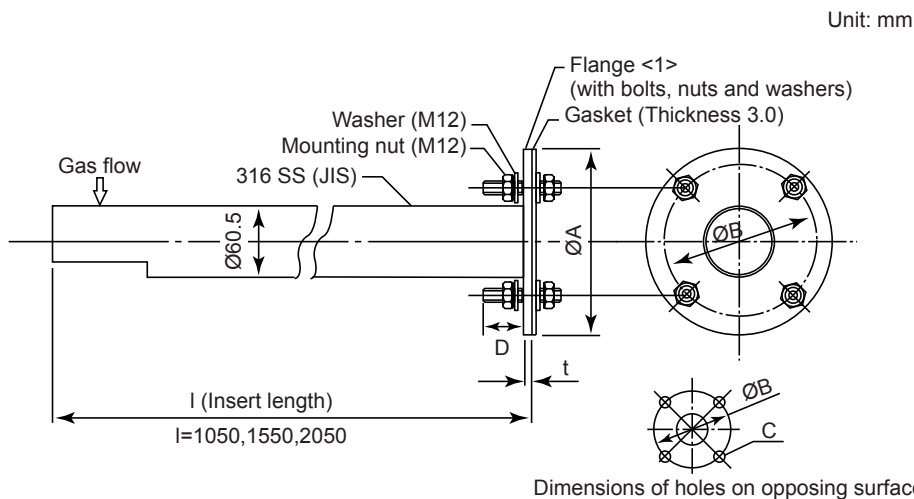

F02-4E.ai

Flange<1>	A	B	C	t	D
JIS 5K 65 FF	155	130	4 - Ø15	5	40
ANSI Class 150 4 FF	228.6	190.5	8 - Ø19	12	50

## 2.3 Separate type Explosion-proof Detector for High Temperature and Related Equipment

### 2.3.1 ZR22S (0.15 m) Separate type Explosion-proof Detector for High Temperature Standard Specifications

Construction:	Water-resistant
Probe length:	0.15 m
Terminal box:	Aluminum alloy
Probe material:	Probe material in contact with gas: 316 SS (JIS), 316L SS (JIS) (Probe), 304 SS (JIS) or ASTM grade 304 (Flange), Zirconia (Sensor), Hastelloy B, (Inconel 600, 601)
Weight:	Approx. 6 kg
Installation:	Flange mounting (When using high temperature detector, high temperature probe adapter ZO21P is necessary.)
Flange standard:	JIS 5K 32 FF equivalent (thickness varies)
Mounting angle:	Any angle between horizontal and vertical downward (high temperature probe is fitted with an adapter)
Reference gas and calibration gas piping connection:	Rc1/4 or 1/4 NPT female
Ambient temperature:	-20 to +60°C (-20 to +150°C on the case surface)
Sample gas temperature:	0 to 700°C (temperature at the measuring point of the sampling gas.) When sample gas is 700°C to 1400°C, the high temperature probe adapter is used.  Temperature of the high temperature probe adapter shall not exceed 300°C to protect the gasket and avoid the bolts seizing together.
Sample gas pressure:	-0.5 to +5 kPa. When using in the range of 0 to 25 vol%O <sub>2</sub> or more, the sample gas pressure should be in the range of -0.5 to +0.5 kPa. (Where the sample gas pressure for the high temperature probe is negative, an auxiliary ejector assembly is necessary.)

Refer to Subsection 2.2.1. for the explosion-proof and other specifications.

- **Model and Code**

Refer to "Model and Codes" in page 2-6.

- **External Dimensions**

Refer to the Figure in page 2-7.

### 2.3.2 ZO21P High Temperature Probe Adapter

Measuring O<sub>2</sub> in the high temperature gases (exceeds 700°C) requires a explosion-proof detector ZR22S of 0.15 m length and a high temperature probe adapter.

Sample gas temperature:

0 to 1400°C (when using SiC probe)  
0 to 800°C (when using 310S SS probe)

Sample gas pressure: -0.5 to +5 kPa. When using in the range of 0 to 25 vol%O<sub>2</sub> or more, the sample gas pressure should be in the range of -0.5 to +0.5 kPa. (Where the sample gas pressure for the high temperature probe is negative, an auxiliary ejector assembly is necessary.)

Insertion length: 0.5, 0.6, 0.7, 0.8, 0.9, 1.0, 1.5 m

Material in Contact with Gas: 316 SS (JIS), SiC or 310S SS, 304 SS (JIS) or ASTM grade 304 (flange)

Probe Material: SiC, 310S SS (JIS)

Installation: Flange mounting (FF type or RF type)

Probe Mounting Angle: Vertically downward within ± 5°. Where the probe material is 310S SS, horizontal mounting is available.

Construction: Non-explosion-proof. Rainproof construction

Weight(example): Insertion length of 1.0 m: approx. 5.3 kg (JIS) / approx. 11.3 kg (ANSI)  
Insertion length of 1.5 m: approx. 5.8 kg (JIS) / approx. 11.8 kg (ANSI)

#### ● Model and Codes

Model	Suffix code	Option code	Description
ZO21P	-H	-----	High Temperature Probe Adapter
Material	-A -B	----- -----	SiC SUS310S
Insertion length	-050 -060 -070 -080 -090 -100 -150	----- ----- ----- ----- ----- ----- -----	0.5 m 0.6 m 0.7 m 0.8 m 0.9 m 1.0 m 1.5 m
Flange	-J -N -M -L -A -R -Q -T -S -E	----- ----- ----- ----- ----- ----- ----- ----- ----- -----	JIS 5K 50 FF JIS 10K 65 FF JIS 10K 80 FF JIS 10K 100 FF ANSI Class 150 4 RF ANSI Class 150 2 1/2 RF ANSI Class 150 3 RF JPI Class 150 3 RF JPI Class 150 4 RF DIN PN10 DN50 A
Style code	*B	-----	Style B
Option	/EJ1 /EJ2 /SCT		Ejector Assy with E7046EC Ejector Assy with E7046EN Stainless steel tag plate

Note:The Insertion length 0.15 m of the ZR22S should be specified.



External Dimension

Unit: mm

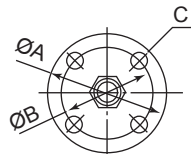
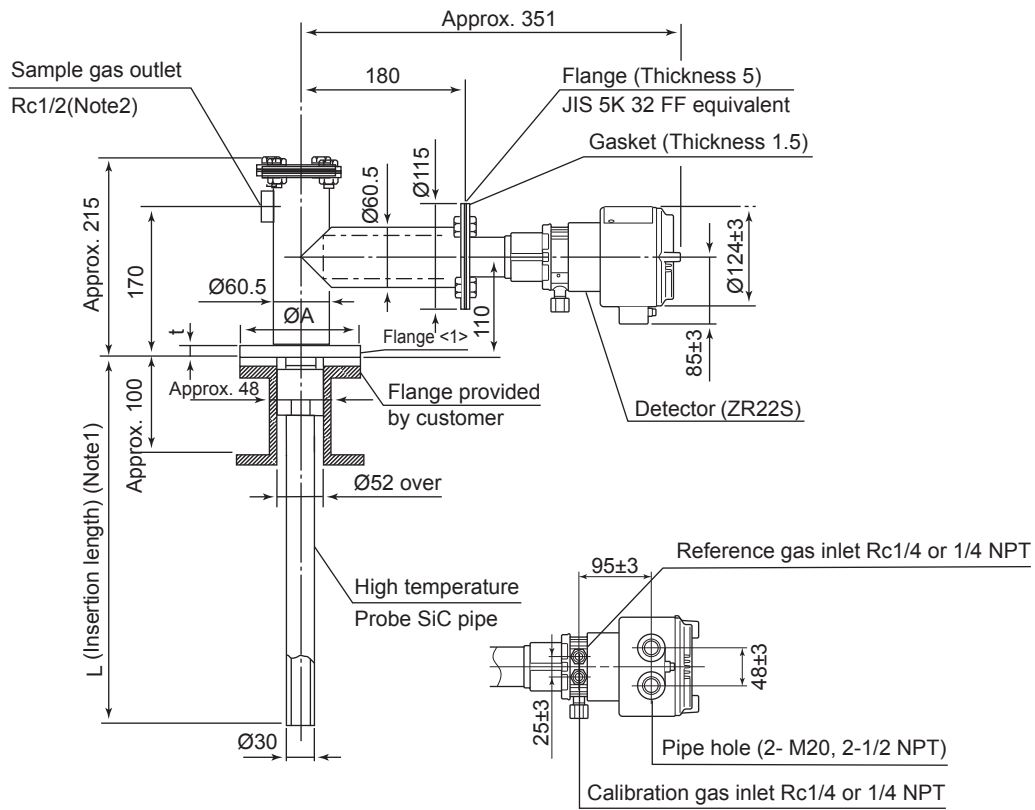

(Note 1) L = 0.5、0.6、0.7、0.8、0.9、1.0、1.5 (m)

(Note 2) Sample gas outlet  
(if the sample gas pressure is negative, connect the ejector assembly.)

F02-5E.ai

<1> Flange	A	B	C	t
JIS 5K 50 FF	130	105	4 - Ø15	14
JIS 10K 65 FF	175	140	4 - Ø19	18
JIS 10K 80 FF	185	150	8 - Ø19	18
JIS 10K 100 FF	210	175	8 - Ø19	18
ANSI Class 150 2 1/2 RF	177.8	139.7	4 - Ø19	22.4
ANSI Class 150 3 RF	190.5	152.4	4 - Ø19	24
ANSI Class 150 4 RF	228.5	190.5	8 - Ø19	24
JPI Class 150 3 RF	190	152.4	4 - Ø19	24
JPI Class 150 4 RF	229	190.5	8 - Ø19	24
DIN PN10 DN50 A	165	126	4 - Ø18	18

## 2.4 ZR402G Separate type Converter

### CAUTION

Converter (Model ZR402G) must not be located in hazardous area.

#### 2.4.1 Standard Specification

The ZR402G Separate type Converter can be controlled by LCD touchscreen on the converter.

Display:	LCD display of size 320 by 240 dot with touchscreen.
Output Signal:	4 to 20 mA DC, two points (maximum load resistance 550 $\Omega$ )
Contact Output Signal:	Four points (one is fail-safe, normally open)
Contact Input:	Two points
Auto-calibration Output:	Two points (for dedicated automatic calibration unit)
Ambient Temperature:	-20 to +55°C
Storage Temperature:	-30 to +70°C
Ambient Humidity:	0 to 95%RH (Non-condensing)
Power Supply Voltage:	Ratings; 100 to 240 V AC, Acceptable range; 85 to 264 V AC
Power Supply Frequency:	Ratings; 50/60 Hz, Acceptable range; 45 to 66 Hz
Power Consumption:	Max. 300 W, approx. 100 W for ordinary use.
Maximum Distance between Detector and Converter:	Conductor two-way resistance must be 10 $\Omega$ or less (when a 1.25 mm <sup>2</sup> cable or equivalent is used, 300 m or less.)
Construction:	Equivalent to NEMA 4X/IP66 (with conduit holes completely sealed with a cable gland)
Wiring Connection:	G1/2, Pg13.5, M20 by 1.5 mm, 1/2 NPT (with plug), eight holes
Installation:	Panel, wall or 2-inch pipe mounting
Case:	Aluminum alloy
Paint Color:	Door: Silver gray (Munsell 3.2PB7.4/1.2) Case: Silver gray (Munsell 3.2PB7.4/1.2)
Finish:	Polyurethane corrosion-resistance coating
Weight:	Approx. 6 kg

## 2.4.2 Functions

### Display Functions:

- Value Display; Displays values of the measured oxygen concentration, etc
- Graph Display; Displays trends of measured oxygen concentration
- Data Display; Displays various useful data for maintenance, such as cell temperature, reference junction temperature, maximum/minimum oxygen concentration, or the like
- Status Message; Indicates an alarm or error occurrence with flashing of the corresponding icon. Indicates status such as warming-up, calibrating, or the like by icons.
- Alarm, Error Display; Displays alarms such as “Abnormal oxygen concentration” or errors such as “Abnormal cell e.m.f.” when any such status occurs.

### Calibration Functions:

- Automatic calibration; Requires the ZR40H Automatic Calibration Unit. It calibrates automatically at specified intervals.
- Semi-auto Calibration; Requires the Automatic Calibration Unit. Input calibration direction on the touchscreen or contact, then it calibrates automatically afterwards.
- Manual Calibration; Calibration with opening/closing the valve of calibration gas in operation interactively with an LCD touchscreen.

### Blow back Function:

- Output through the contact in the set period and time. Auto/Semi\_Auto selectable.

### Maintenance Functions:

- Can operate updated data settings in daily operation and checking. Display data settings, calibration data settings, blow back data settings, current output loop check, contact input/output check.

### Setup Functions:

- Initial settings suit for the plant conditions when installing the converter.
- Equipment settings, current output data settings, alarm data settings, contact data settings, other settings.

### Self-diagnosis:

- This function diagnoses conditions of the converter or the detector and indicates when any abnormal condition occurs.

### Password Functions:

- Enter your password to operate the analyzer excepting data display. Individual passwords can be set for maintenance and setup.

- **Display and setting content:**

Measuring Related Items: Oxygen concentration (vol%O<sub>2</sub>), output current value (mA), air ratio, moisture quantity (in hot gases) (vol% H<sub>2</sub>O)

Display Items: Cell temperature (°C), thermocouple reference junction temperature (°C), maximum/minimum/average oxygen concentration (vol% O<sub>2</sub>), cell e.m.f. (mV), cell internal resistance (Ω), cell condition (in four grades), heater on-time rate (%), calibration record (ten times), time (year/month/day, hour/minute)

Calibration Setting Items: Span gas concentration (vol%O<sub>2</sub>), zero gas concentration (vol%O<sub>2</sub>), calibration mode (automatic, semi-automatic, manual), calibration type and method (zero-span calibration, zero calibration only, span calibration only), stabilization time (min.sec), calibration time (min.sec), calibration interval (day/hour), starting time (year/month/day, hour/minute)

Equipment Related Items: Sample (Measuring) gas selection

Output Related Items: Analog output/output mode selection, output conditions when warming-up/maintenance/calibrating (during blow back)/abnormal, 4 mA/20 mA point oxygen concentration (vol%O<sub>2</sub>), time constant.

Alarm Related Items: Oxygen concentration high alarm/high-high alarm limit values (vol%O<sub>2</sub>), oxygen concentration low alarm/low-low alarm limit values (vol%O<sub>2</sub>), oxygen concentration alarm hysteresis (vol%O<sub>2</sub>), oxygen concentration alarm detection, alarm delay (seconds)

Contact Related Items: Selection of contact input 1 and 2, selection of contact output 1 to 4 (abnormal, high-high alarm, high alarm, low alarm, low-low alarm, maintenance, calibrating, range switching, warming-up, calibration gas pressure decrease, temperature high alarm, blow back, flameout gas detection, calibration coefficient (correction ratio) alarm, stabilization timeout)

Converter Output: Two points mA analog output (4 to 20 mA DC (maximum load resistance of 550 Ω)) and one mA digital output point (HART) (minimum load resistance of 250 Ω).

Range: Any setting between 0 to 5 through 0 to 100 vol%O<sub>2</sub> in 1 vol%O<sub>2</sub>, or partial range is available (Maximum range value/minimum range value 1.3 or more). For the log output, the minimum range value is fixed at 0.1 vol%O<sub>2</sub>.  
4 to 20 mA DC linear or log can be selected. Input/output isolation.

Output damping: 0 to 255 seconds. Hold / non-hold selection, preset value setting possible with hold.

Contact Output: Four points, contact capacity 30 V DC 3 A, 250 V AC 3 A (resistive load) Three of the output points can be selected to either normally energized or normally de-energized status.  
Delayed functions (0 to 255 seconds) and hysteresis function (0 to 9.9 vol%O<sub>2</sub>) can be added to high/low alarms.

The following functions are programmable for contact outputs.

(1) Abnormal, (2) High-high alarm, (3) High alarm, (4) Low-low alarm, (5) Low alarm, (6) Maintenance, (7) Calibration, (8) Range switching answer-back, (9) Warm-up, (10) Calibration gas pressure decrease (answer-back of contact input), (11) Temperature high alarm, (12) Blow back start, (13) Flameout gas detection (answer-back of contact input), (14) Calibration coefficient (correction ratio) alarm, (15) Startup power stabilization timeout alarm

Contact output 4 is set to normally operated, and fixed error status.

- Contact Input: Two points (voltage-free)  
 The following functions are programmable for contact inputs:  
 (1) Calibration gas pressure decrease alarm, (2) Range switching,  
 (3) External calibration start, (4) Process alarm (if this signal is received,  
 the heater power turns off), (5) Blow back start
- Contact capacity: Off-state leakage current; 3 mA or less
- Self-diagnosis: Abnormal cell, abnormal cell temperature (low/high), abnormal  
 calibration, defective A/D converter, defective digital circuit
- Calibration: Method; zero/span calibration  
 Calibration mode; automatic, semi-automatic and manual (All are operated  
 interactively with an LCD touchscreen). Either zero or span can be skipped.  
 Zero calibration gas concentration setting range: 0.3 to 100 vol%O<sub>2</sub> (in increments of  
 0.01 vol%O<sub>2</sub> in smallest units).  
 Span calibration gas concentration setting range: 4.5 to 100 vol%O<sub>2</sub> (in increments of  
 0.01 vol%O<sub>2</sub> in smallest units).  
 Use nitrogen-balanced mixed gas containing 0 to 10 vol%O<sub>2</sub> scale of  
 oxygen, and 80 to 100 vol%O<sub>2</sub> scale of oxygen for standard zero gas  
 and standard span gas respectively.  
 Calibration interval; date/time setting: maximum 255 days

● **Model and Codes**

Model	Suffix code	Option code	Description
ZR402G	-----	-----	Separate type Zirconia Oxygen Analyzer, Converter
Converter thread	-P -G -M -T	----- ----- ----- -----	G1/2 Pg13.5 M20x1.5 1/2NPT
Display	-J -E -G -F -C -P	----- ----- ----- ----- ----- -----	Japanese English German French Chinese Portuguese
Instruction manual	-J -E -C	----- ----- -----	Japanese English Chinese
—	-A	-----	Always -A
Options	Tag plates NAMUR NE43 compliant Standard	/H /SCT /PT /C2 /C3 /EQ /ER	Hood (*2) Stainless steel tag plate (*1) Printed tag plate (*1) Failure alarm down-scale: Output status at CPU failure and hardware error is 3.6 mA or less (*3) Failure alarm up-scale: Output status at CPU failure and hardware error is 21.0 mA or more (*3) EAC with PA (*4) EAC (*4)

\*1 Specify either /SCT or /PT option code.  
 \*2 Sun shield hood is still effective even if scratched.  
 \*3 Output signal limits: 3.8 to 20.5 mA. Specify either /C2 or /C3 option code.  
 \*4 "/EQ" is EAC with Pattern Approval for Russia. "/ER" is EAC for Kazakhstan and Belarus.

● **Standard Accessories**

Item	Parts No.	Q'ty	Description
Fuse	A1113EF	1	3.15A
Bracket for mounting	F9554AL	1	For pipe, panel or wall mounting
Screw for Bracket	F9123GF	1	

● External Dimensions

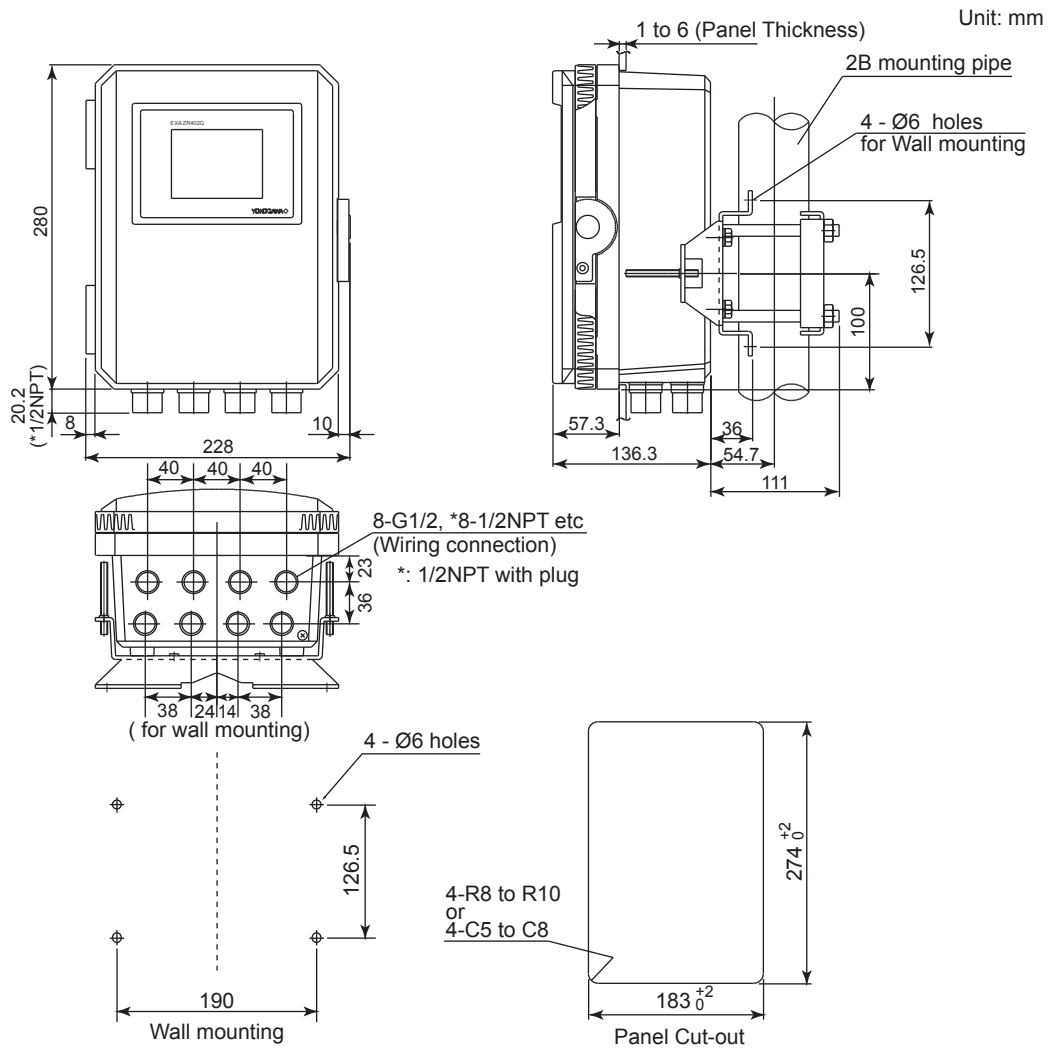

F02-6E.ai

● With sun shield hood (option code /H)

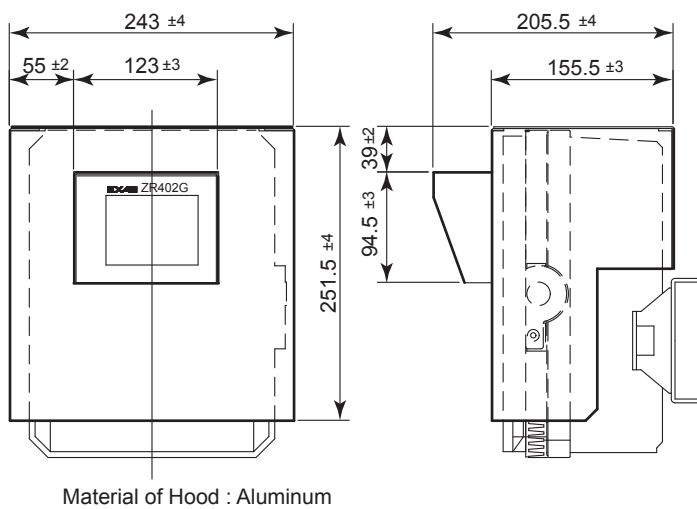

F02-7E.ai

## 2.5 ZA8F Flow Setting Unit and ZR40H Automatic Calibration Unit

### 2.5.1 ZA8F Flow Setting Unit

This flow setting unit is applied to the reference gas and the calibration gas in a system configuration (System 1). Used when instrument air is provided.

This unit consists of a flowmeter and flow control valves to control the flow rates of calibration gas and reference gas.

#### Standard Specifications

Construction:	Dust-proof and rainproof construction
Case Material:	SPCC (Cold rolled steel sheet)
Flowmeter Scale:	Calibration gas; 0.1 to 1.0 L/min. Reference gas; 0.1 to 1.0 L/min.
Painting:	Baked epoxy resin, Dark-green (Munsell 2.0 GY 3.1/0.5 or equivalent)
Tube Connections:	Rc1/4 or 1/4FNPT
Reference Gas Pressure:	Clean air supply of sample gas pressure plus approx. 50 kPaG (or sample gas pressure plus approx. 150 kPaG when a check valve is used). Pressure at inlet of the Flow Setting Unit. (Maximum 300 kPaG)
Reference Gas Consumption:	Approx. 1.5 L/min
Calibration Gas (zero gas, span gas) Consumption:	Approx. 0.7 L/min (at calibration time only)
Weight:	Approx. 2.3 kg

#### NOTE

Use instrument air for span calibration gas, if no instrument air is available, contact YOKOGAWA.

#### ● Model and Codes

Model	Suffix code	Option code	Description
ZA8F	-----	-----	Flow setting unit
Joint	-J -A	----- -----	Rc 1/4 With 1/4 NPT adapter
Style code	*C	-----	Style C

● External Dimensions

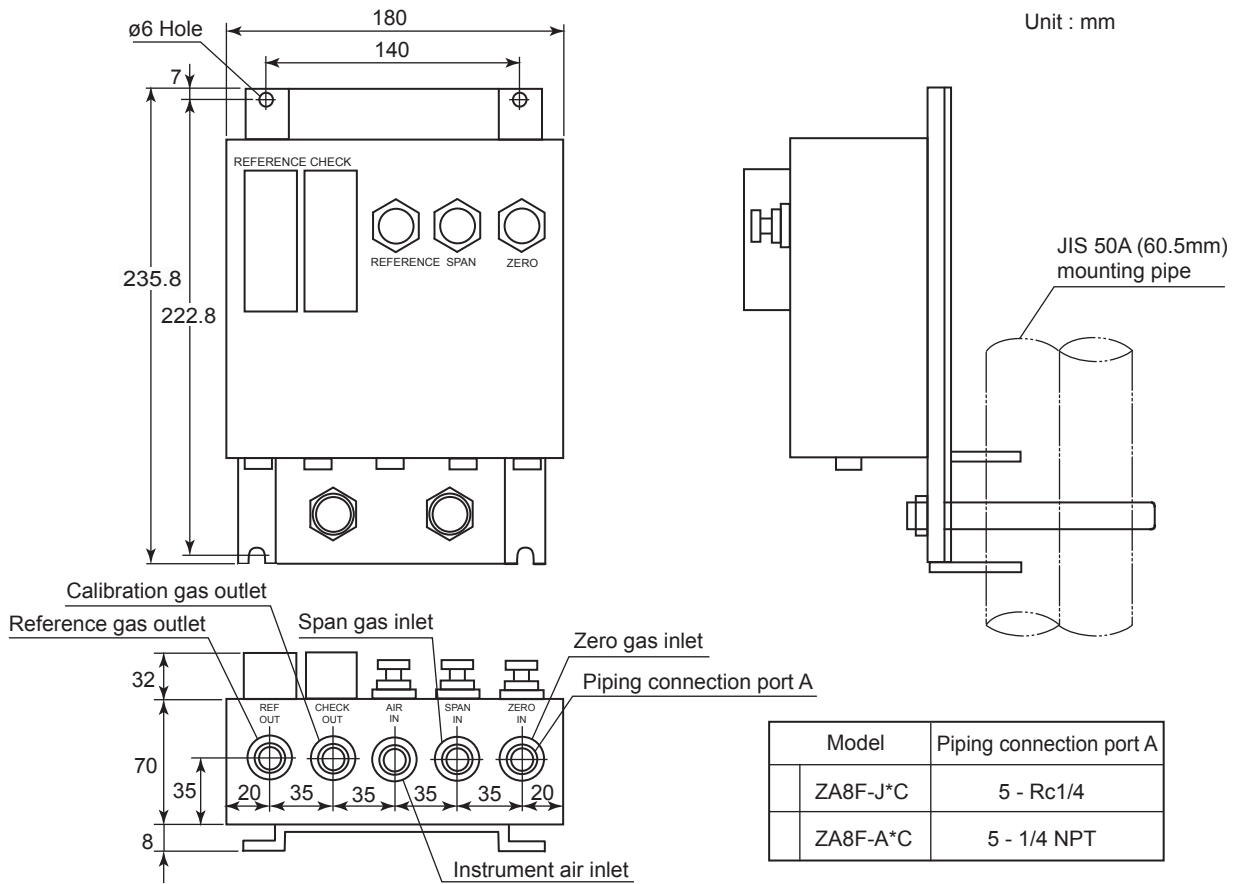

Weight : Approx. 2.3 kg

PIPING INSIDE THE FLOW SETTING UNIT

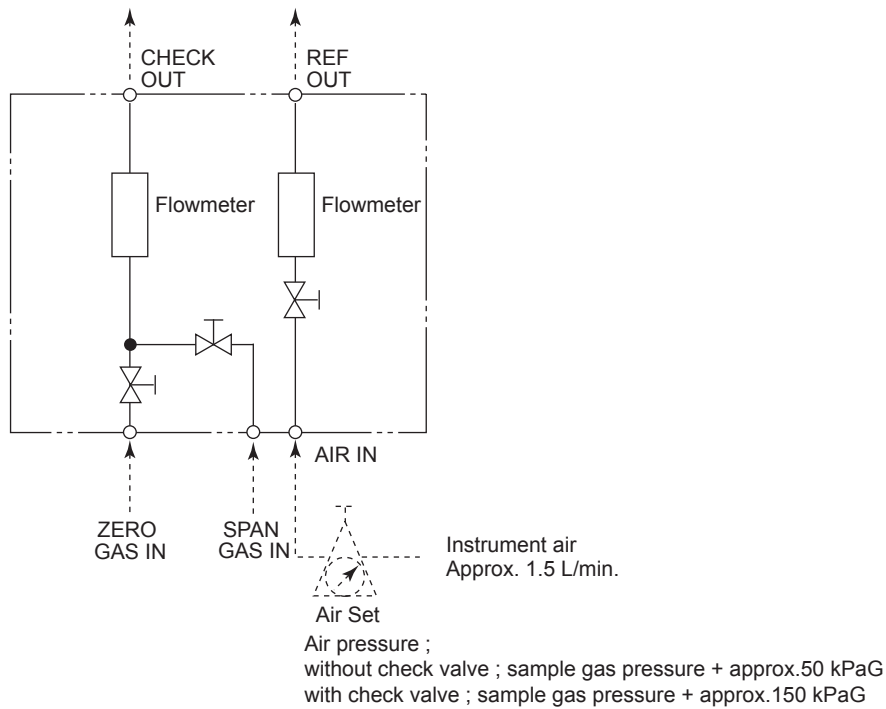

F02-8E.ai



### 2.5.2 ZR40H Automatic Calibration Unit

 **CAUTION**

Automatic Calibration Unit (Model ZR40H) must not be located in hazardous area.

This automatic calibration unit is applied to supply specified flow of reference gas and calibration gas during automatic calibration to the detector in a system configuration (System 2).

● **Specifications**

Used when auto calibration is required for the separate type and instrument air is provided. The solenoid valves are provided as standard.

- Construction: Dust-proof and rainproof construction:  
NEMA4X/IP67-only for case coating solenoid valve (excluding flowmeter)
- Mounting: 2-inch pipe or wall mounting, no vibration
- Materials: Body; Aluminum alloy,  
Piping; 316 SS (JIS), 304 SS (JIS),  
Flowmeter; MA (Metha acrylate resin).  
Bracket; 304 SS (JIS)
- Finish: Polyurethane corrosion-resistance coating, mint green (Munsell 5.6BG3.3/2.9)
- Piping Connection: Refer to Model and Codes
- Power Supply: 24 V DC (from ZR402G), Power consumption; Approx. 1.3 W
- Reference Gas Pressure: Sample gas pressure plus approx. 150 kPa (690 kPa max.), (Pressure at inlet of the Automatic Calibration Unit)
- Air Consumption: Approx. 1.5 L/min
- Weight: Approx. 3.5 kg
- Ambient Temperature: -20 to +55°C, no condensation or freezing
- Ambient Humidity: 0 to 95%RH
- Storage Temperature: -30 to +65°C

● **Model and Codes**

Model	Suffix code	Option code	Description
ZR40H	-----	-----	Automatic calibration unit for ZR402G
Gas piping connection	-R	-----	Rc 1/4
	-T	-----	1/4 NPT
Wiring connection	-P	-----	Pipe connection (G1/2)
	-G	-----	Pg 13.5
	-M	-----	20 mm (M20 x 1.5)
	-T	-----	1/2 NPT
—	-A	-----	Always -A

● External Dimensions

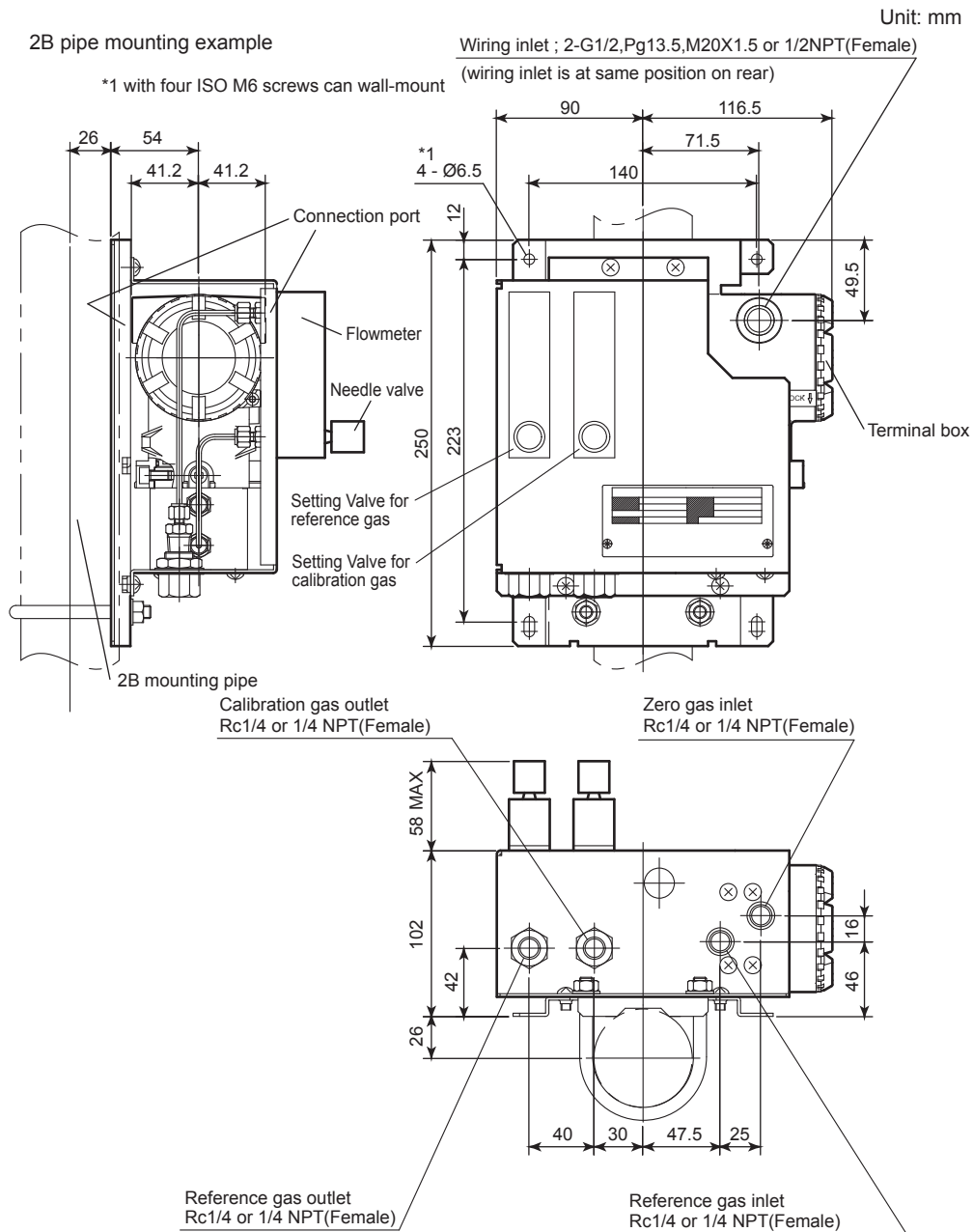

F02-9E.ai

● Piping Diagram

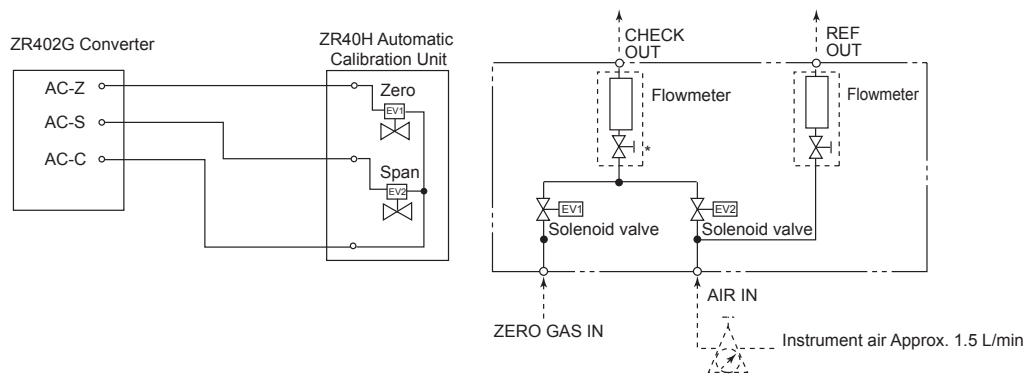

\*Needle valve is supplied as an accessory with flowmeter F02-10E.ai

## 2.6 ZO21S Standard Gas Unit

### CAUTION

Standard Gas Unit (Model ZO21S) must not be located in hazardous area.

This is a handy unit to supply zero gas and span gas to the detector as calibration gas. It is used in combination with the detector only during calibration.

The ZO21S does not conform to CE marking.

#### ● Standard Specifications

Function: Portable unit for calibration gas supply consisting of span gas (air) pump, zero gas cylinder with sealed inlet, flow rate checker and flow rate needle valve.

Sealed Zero Gas Cylinders (6 provided): E7050BA

Capacity: 1 l

Filled pressure: Approx. 686 kPaG (at 35°C)

Composition: 0.95 to 1.0 vol%O<sub>2</sub> + N<sub>2</sub> balance

Power Supply: 100, 110, 115, 200, 220, 240 V AC ±10%, 50/60 Hz

Power Consumption: Max. 5 VA

Case material: SPCC (cold rolled steel sheet)

Paint Color: Mainframe; Munsell 2.0 GY3.1/0.5 equivalent  
Cover; Munsell 2.8 GY6.4/0.9 equivalent

Piping: Ø6 x Ø4 mm flexible tube connection

Weight: Approx. 3 kg

#### ● Model and Codes

Model	Suffix code	Option code	Description
ZO21S	-----	-----	Standard gas unit
Power supply	-2	-----	200 V AC 50/60 Hz
	-3	-----	220 V AC 50/60 Hz
	-4	-----	240 V AC 50/60 Hz
	-5	-----	100 V AC 50/60 Hz
	-7	-----	110 V AC 50/60 Hz
	-8	-----	115 V AC 50/60 Hz
Panel	-J	-----	Japanese version
	-E	-----	English version
Style code		*A	Style A

#### ● External Dimensions

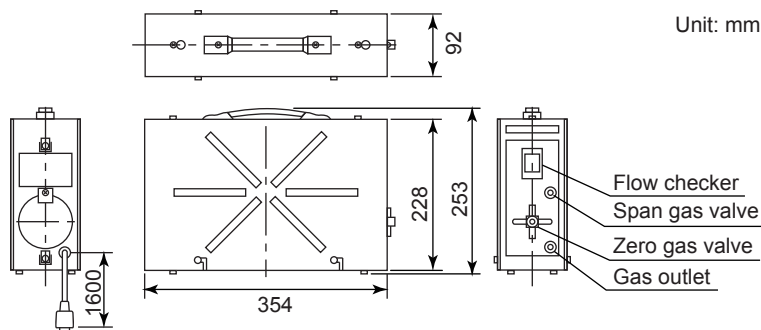

Zero gas cylinder (6 cylinder): E7050BA

F02-11E.ai

## 2.7 Other Equipments

### 2.7.1 Ejector Assembly for High Temperature (E7046EC, E7046EN)

This ejector assembly is used where pressure of sample gas for high temperature detector is negative. This ejector assembly consists of an ejector, a pressure gauge assembly and a needle valve.

#### ● Standard Specifications

##### Needle Valve

Connection: Rc1/4 or 1/4 FNPT

Material: 316 SS (JIS)

##### Pressure Gauge Assembly

Material in Contact with Gas: 316 SS (JIS)

Case Material: Aluminum alloy (Paint color; black)

Connection: G3/8 x R1/4 or 1/4 FNPT

Scale: 0 to 100 kPaG

##### Ejector

Ejector Inlet Air Pressure: 29 to 69 kPaG

Air Consumption: Approx. 30 to 40 L/min

Suction gas flow rate: 3 to 7 L/min

Connection to Blow: Rc1/4, 304 SS (JIS)

Tube Connection: Ø 6 / Ø 4 mm or 1/4 inch copper tube (stainless tube)

(Note) Pipe and connections are not provided.

Part No.	Description
E7046EC	Needle valve; Rc1/4, Ejector; Ø6 / Ø4 TUBE joint, Pressure gauge; R1/4
E7046EN	Needle valve; 1/4 FNPT, Ejector; 1/4 TUBE joint, Pressure gauge; 1/4 NPT

#### ● Dimension

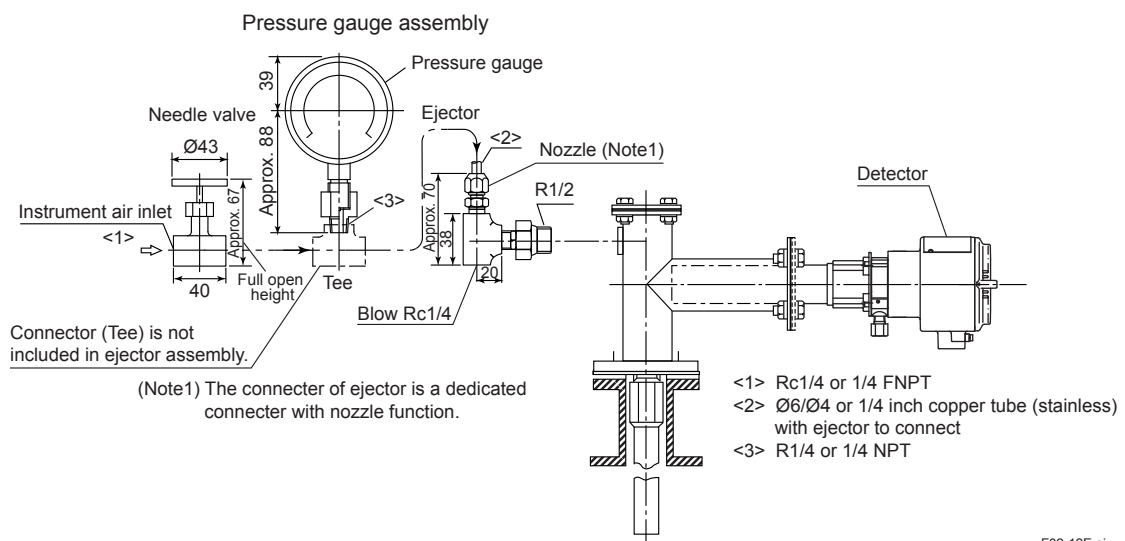

F02-12E.ai

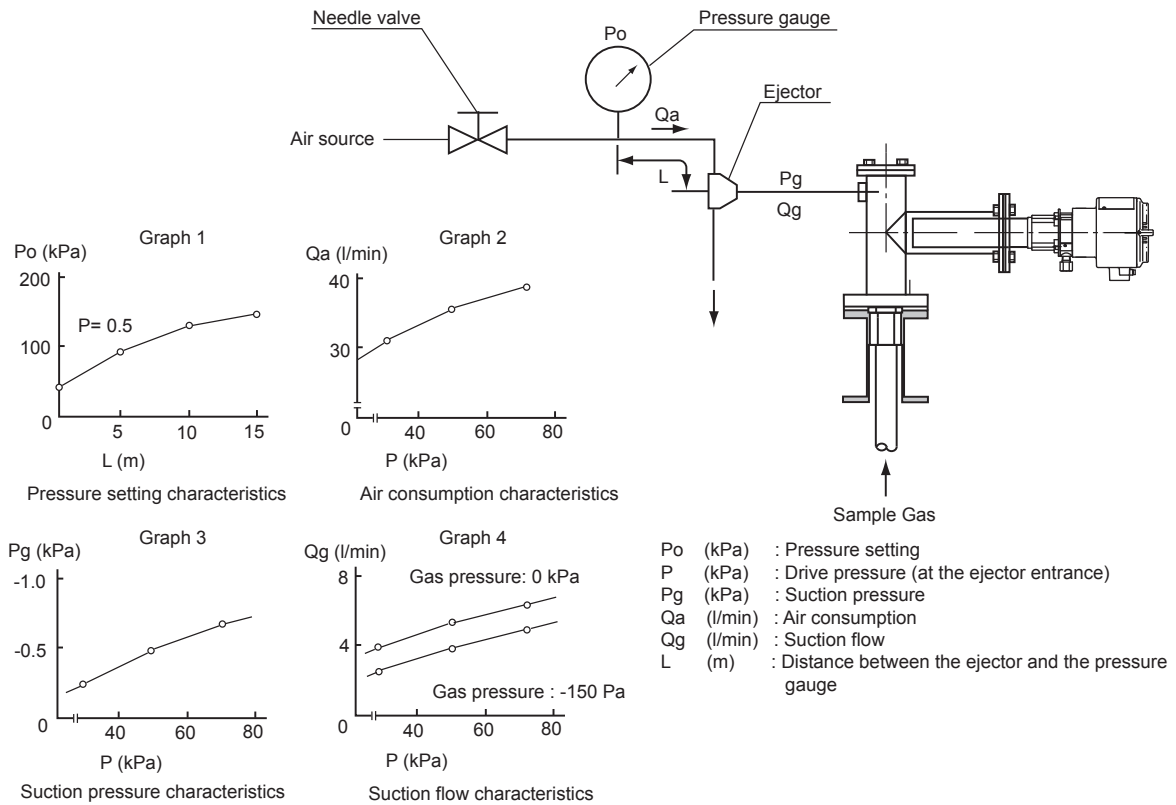

F02-13E.ai

< **Pressure setting for the ejector for high temperature use** >

Pressure supply for the ejector should be set so that the suction flow of the sample gas becomes approximately 5 L/min.

To set this, proceed as follows:

- (1) In Graph 4, draw a horizontal line from the 5 L/min point on the vertical axis (Suction flow: Qg) toward the gas pressure line to be used, to find the point of intersection. Draw a line vertically down from the point of intersection to the axis to find the drive pressure, P (at the ejector entrance).
- (2) In Graph 1, determine Po (pressure setting) from L (the distance between the ejector and the pressure gauge).
- (3) Open the needle valve to supply air for the ejector to the pressure gauge until it indicates the pressure setting, Po.

**NOTE**

Qg (the suction flow) may require change according to the conditions of use. Refer to Subsection 3.2.2 and Subsection 4.1.4 for details.

**Graph explanation**

- 1) Graph 1 is to compensate for pressure loss in piping between the ejector and the pressure gauge, and find Po (pressure setting).
- 2) Graph 2 shows correlation between P (drive pressure) and Qa (air consumption).
- 3) Graph 3 shows correlation between P (drive pressure) and Pg (suction pressure; when the sample gas inlet of the ejector is closed).
- 4) Graph 4 shows correlation between P (drive pressure) and Qg (suction flow) for each gas pressure.

### 2.7.2 Stop Valve (L9852CB, G7016XH)

This valve mounted on the calibration gas line in the system using ZA8F flow setting unit for manual calibration.

- **Standard Specifications**

Material: 316 SS (JIS)  
 Connection: Rc 1/4 or 1/4 FNPT  
 Weight: Approx. 200 g

Part No.	Description
L9852CB	Joint: Rc 1/4, Material: 316 SS (JIS)
G7016XH	Joint: 1/4 FNPT, Material: 316 SS (JIS)

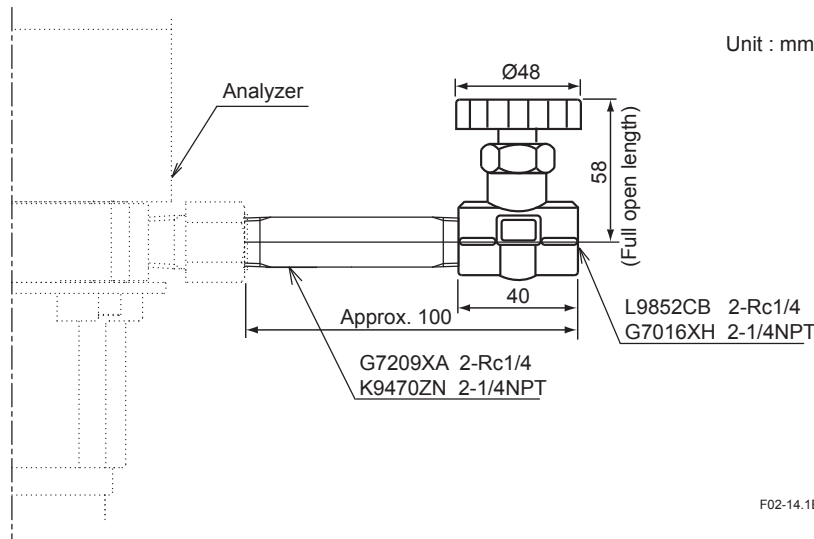

F02-14.1E.ai

### 2.7.3 Check Valve (K9292DN, K9292DS)

This valve is mounted on the calibration gas line (directly connected to the detector). This valve prevents the sample gas from entering the calibration gas line. Although it functions as a stop valve, operation is easier than a stop valve as it does not require opening/closing at each calibration. Screw a check valve, instead of a stop valve into the calibration gas inlet of the detector.

- **Standard Specifications**

Material: 304 SS (JIS)  
 Connection: Rc1/4 or 1/4 FNPT  
 Pressure: 150 kPaG or more and 350 kPaG or less  
 Weight: Approx. 90 g

Part No.	Description
K9292DN	Joint: Rc 1/4, Material: 304 SS (JIS)
K9292DS	Joint: 1/4 FNPT, Material: 304 SS (JIS)

K9292DN : Rc 1/4(A),R 1/4(B)      Unit: mm  
 K9292DS : 1/4 FNPT(A),1/4 NPT(Male)(B)

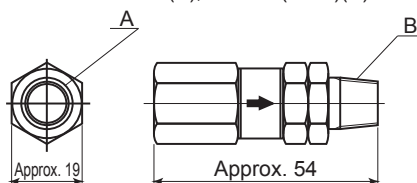

F02-15E.ai

### 2.7.4 Air Set

This set is used to lower the pressure when instrument air is used as the reference and span gases.

#### Standard Specifications

• **G7003XF, K9473XK**

Primary Pressure: Max. 1 MPaG  
 Secondary Pressure: 0.02 to 0.2 MPaG  
 Connection: Rc1/4 or 1/4 FNPT (with joint adapter)  
 Weight: Approx. 1 kg

Part No.	Description
G7003XF	Joint: Rc 1/4, Material: Zinc alloy
K9473XK	Joint: 1/4 FNPT (with joint adapter), Material: Zinc alloy, Adapter: 316 SS (JIS)

• **G7004XF, K9473XG**

Primary Pressure: Max. 1 MPaG  
 Secondary Pressure: 0.02 to 0.5 MPaG  
 Connection: Rc1/4 or 1/4 FNPT with joint adapter  
 Weight: Approx. 1 kg

Part No.	Description
G7004XF	Joint: Rc 1/4, Material: Zinc alloy
K9473XG	Joint: 1/4 FNPT (with joint adapter), Material: Zinc alloy, Adapter: 316 SS (JIS)

### External Dimensions

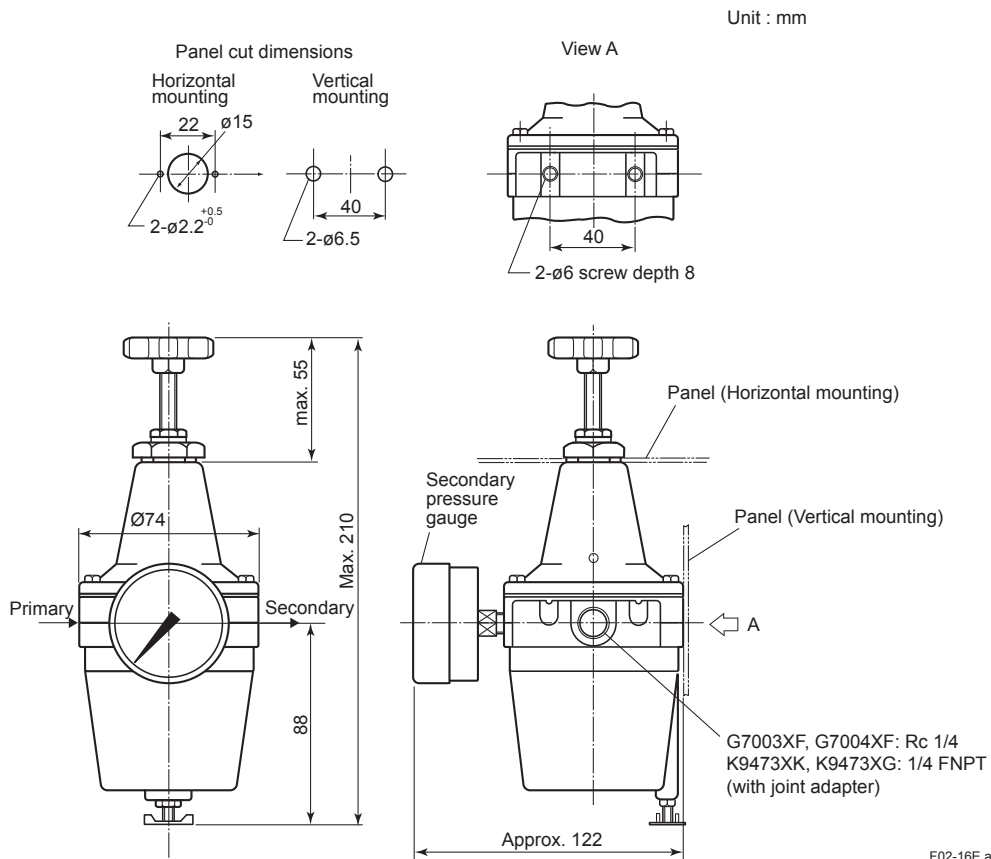

F02-16E.ai

### 2.7.5 Cylinder Pressure Reducing Valve (G7013XF, G7014XF)

This pressure reducing valve is used with the zero gas cylinders.

- Standard Specifications**

- Primary Pressure: Max. 14.8 MPaG
- Secondary Pressure: 0 to 0.4 MPaG
- Connection: Inlet; W22 14 threads, right hand screw  
Outlet; Rc1/4 or 1/4 FNPT
- Material: Brass body

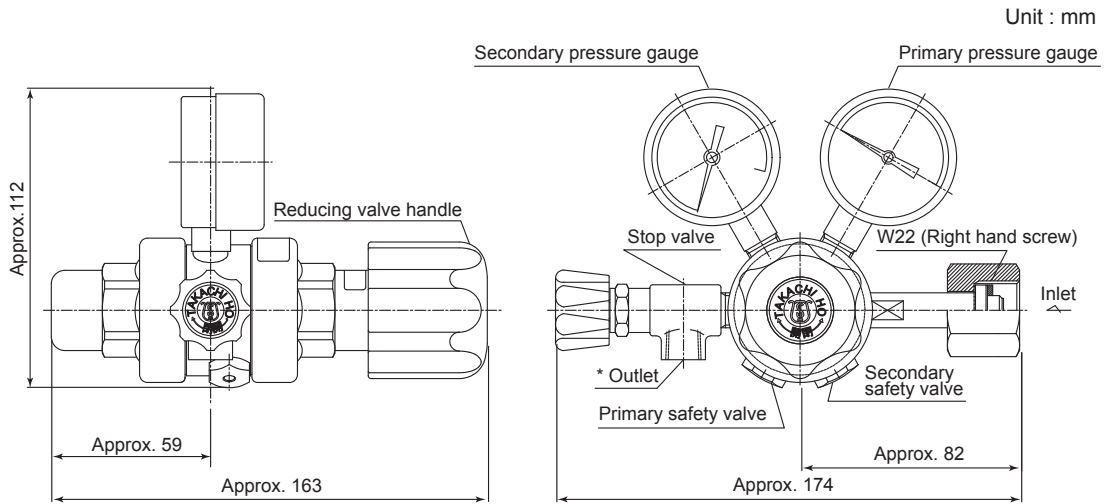

Part No.	* Outlet
G7013XF	Rc1/4
G7014XF	1/4 NPT female with adapter

F02-17E.ai



### 2.7.6 ZR22A Heater Assembly

#### ● Model and Codes

Style:2

Model	Suffix code	Option code	Description
ZR22A	-----	-----	Heater Assembly for ZR22S
Length (*1)	-015	-----	0.15 m
	-040	-----	0.4 m
	-070	-----	0.7 m
	-100	-----	1 m
	-150	-----	1.5 m
	-200	-----	2 m
Jig for change	-A	-----	with Jig (*2)
	-N	-----	None
—	-A	-----	Always-A

\*1 Suffix code of length should be selected as same as ZR22S installed.

\*2 Jig part no. is K9470BX to order as a parts after purchase.

(Note) The heater is made of ceramic, do not drop or subject it to pressure stress.

Yokogawa shall not guarantee the heater assembly after its replacement.

#### ● External Dimensions

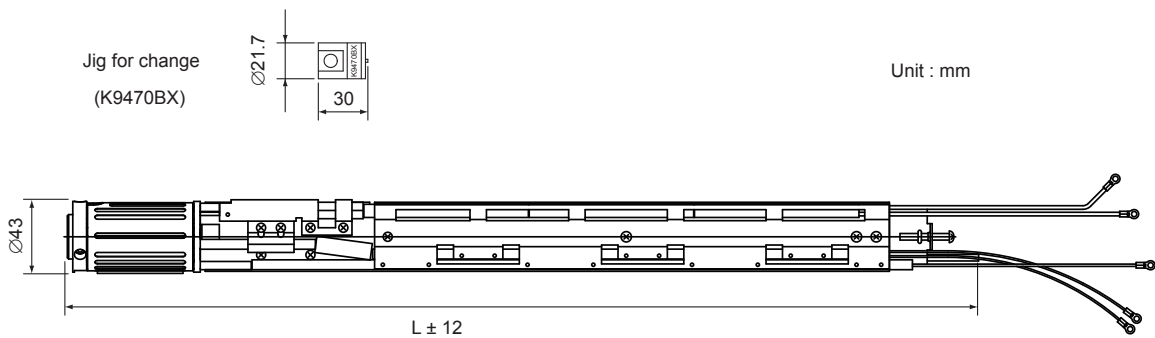

Unit : mm

Model & Codes	L	Weight (kg)
ZR22A-015	302	Approx. 0.5
ZR22A-040	552	Approx. 0.8
ZR22A-070	852	Approx. 1.2
ZR22A-100	1152	Approx. 1.6
ZR22A-150	1652	Approx. 2.2
ZR22A-200	2152	Approx. 2.8

F02-18E.ai

# 3. Installation

This chapter describes installation of the following equipment:

- Section 3.1 General-purpose Detector (except ZR22S-□-015)
- Section 3.2 High Temperature Detector (ZR22S-□-015)
- Section 3.3 ZR402G Converter
- Section 3.4 ZA8F Flow Setting Unit
- Section 3.5 ZR40H Automatic Calibration Unit

## ! CAUTION

ZR402G Converter and ZR40H Automatic Calibration Unit must not be located in hazardous area.

## ! CAUTION

Requirement for explosion-proof use:

The ZR22S is connected to a ZR402G or AV550G\*1 that is mounted in a non-hazardous area. The ambient temperature is in the range -20 to +60°C. The surface temperature of the ZR22S is not over the temperature class T2 (300°C)\*2.

\*1: Refer to IM 11M12D01-01E

\*2: The terminal box temperature does not exceed 150°C.

Oxygen concentration of sample/reference/calibration gas shall not exceed that found in normal air, typically 21 vol%.

## ! CAUTION

- When connecting an AV550G, the AV550G should be installed in a non-hazardous area.
- When using options like automatic calibration or blow back, if the corresponding solenoid valves are to be mounted in a hazardous location then be sure to use explosion-proof solenoid valves and appropriate wiring in explosion-proof conduit.

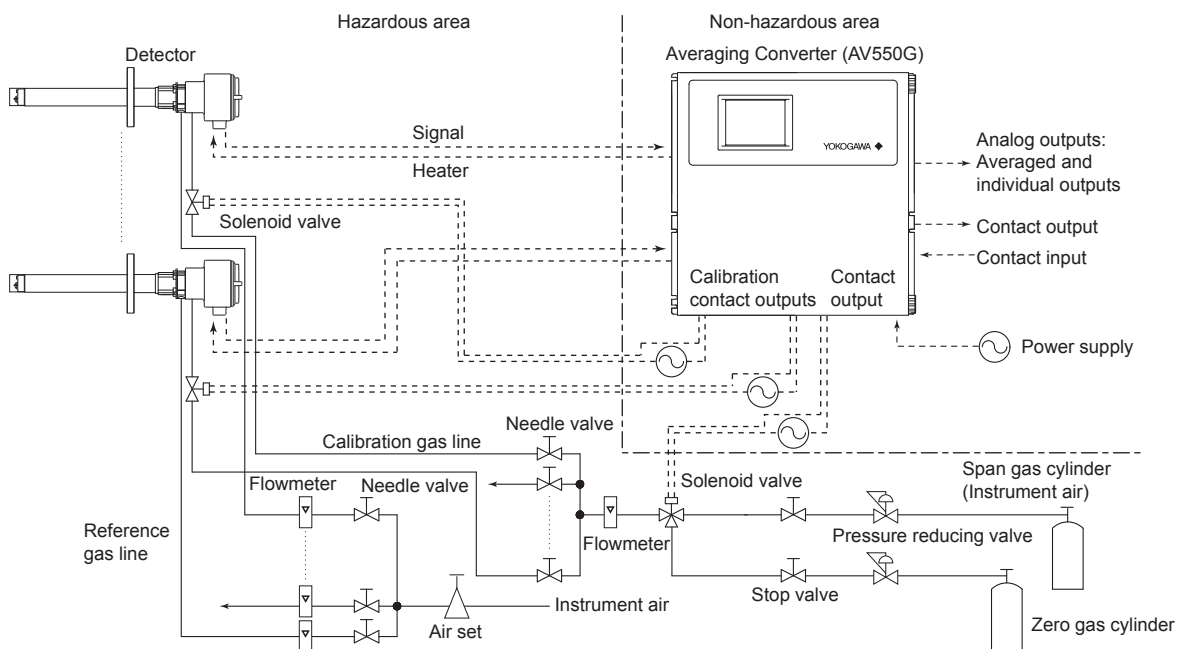

F03-1E.ai

**Figure 3.1 Connection with AV550G**

Regarding the AV550G installation procedure, refer to IM 11M12D01-01E.

## 3.1 Installation of General-purpose Detector

### 3.1.1 Installation Location

The following should be taken into consideration when installing the detector:

- (1) Easy and safe access to the detector for checking and maintenance work.
- (2) An ambient temperature of not more than 60°C, and the terminal box should not be affected by radiant heat.
- (3) A clean environment without any corrosive gases.
- (4) No vibration.
- (5) The sample gas satisfies the specifications described in Chapter 2.
- (6) No sample gas pressure fluctuations.
- (7) The installation must be in accordance with IEC 60079-14 and relevant local codes.

### 3.1.2 ATEX Flameproof Type

ZR22S-A Detector for use in hazardous locations:

Note 1: Applicable Standard: EN IEC 60079-0: 2018, EN 60079-1: 2014, EN 60079-31: 2014

Certificate Number: KEMA 04ATEX2156 X

The symbol "X" placed after certificate number indicates that the equipment is subjected to special conditions for safe use. Refer to Note 6.

Type of protection: Ex db IIB+H<sub>2</sub> T2 Gb, Ex tb IIIC T300°C Db

Equipment Group: II

Category: 2GD

Temperature class for Ex "db": T2

The maximum surface temperature for Ex "tb": T300°C

Degree of protection of enclosure: IP66

Note 2: Wiring

- All wiring shall comply with local installation requirement.

Note 3: Operation

- Keep to "WARNING" on the Detector.

**WARNING: DO NOT OPEN WHEN AN EXPLOSIVE GAS ATMOSPHERE IS PRESENT  
POTENTIAL ELECTROSTATIC CHARGING HAZARD-READ USER'S MANUAL (IM11M13A01-02)  
FOR INSTALLATION AND SAFE USE, READ IM11M13A01-02  
USE AT LEAST 150°C HEAT RESISTANT CABLES & CABLE GLANDS**

- Take care not to generate mechanical sparking when accessing to the detector and peripheral devices in hazardous location

Note 4: Maintenance and Repair

- The detector modification or parts replacement by other than authorized representative of Yokogawa Electric Corporation is prohibited and will void the certification.

Note 5: Cable Entry

- The threaded type of cable entry is marked beside the cable entry according to the following markings.

Threaded type :	Marking
M20 x 1.5 :	M
1/2 NPT :	N

- The cable entry devices (cable glands etc.) and blind plugs shall be in type of protection Ex “db” or Ex “tb”, suitable for the conditions of use and correctly installed. They shall provide a degree of ingress protection of at least IP66.

Note 6: Special conditions for safe use

Electrostatic charge may cause an explosion hazard. Avoid any actions that cause the generation of electrostatic charge, such as rubbing with a dry cloth.

If it is mounted in the area where the use of Ex “tb” apparatus is required, it shall be installed in such a way that the risk from electrostatic discharges and propagating brush discharges caused by rapid flow of dust is avoided.

Note 7: Special fastener

Hexagon socket head cap screws below are special fastener according to EN IEC 60079-0: 2018 (see the figure below). Material property classes of them are A2-50 or better.

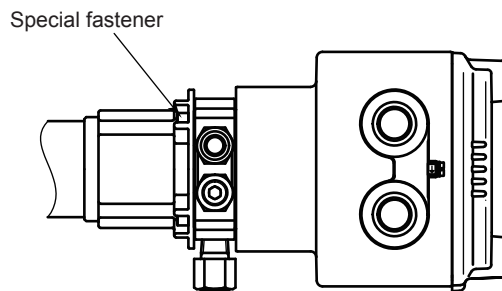

Figure 3.2 Special fastener

### 3.1.3 FM Explosion-proof Type

ZR22S-B Detector for use in hazardous locations:

Note 1: Applicable Standard: FM3600 2011, FM3615 2006, FM3810 2005, ANSI/NEMA 250 1991

Type of protection: Explosion-proof for Class I, Division 1, Groups B, C and D

Dust-ignitionproof for Class II/III, Division 1, Groups E, F and G

Enclosure Rating: NEMA 4X

Temperature Class: T2

Note 2: Wiring

- All wiring shall comply with National Electrical Code ANSI/NEPA 70 and Local Electrical Code.

- In hazardous location, wiring shall be in conduits as shown in the figure.

WARNING: SEAL ALL CONDUITS WITHIN 18 INCHES OF THE ENCLOSURE.

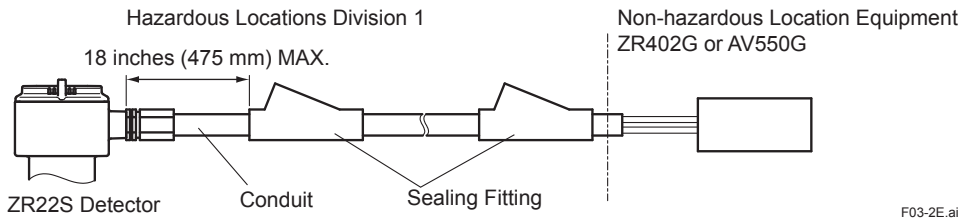

Figure 3.3 Wiring of ZR22S-B

Note 3: Operation

- Keep the “WARNING” label to the Detector.

**WARNING:** OPEN CIRCUIT BEFORE REMOVING COVER. USE AT LEAST 150°C HEAT RESISTANT CABLES.

- Take care not to generate mechanical sparking when accessing to the detector and peripheral devices in hazardous location

Note 4: Maintenance and Repair

- The detector modification or parts replacement by other than authorized representative of Yokogawa Electric Corporation is prohibited and will void Factory Mutual Explosion-proof Approval.

### 3.1.4 CSA Explosion-proof Type

ZR22S-C Detector for use in hazardous locations:

Note 1: Applicable Standard: C22.2 No.0-M1991, C22.2 No.0.4-04, C22.2 No.0.5-1982, C22.2 No.25-1966, C22.2 No.30-M1986, C22.2 No.94-M91, C22.2-No.61010-1-04

Certificate Number: 1649642

Type of protection: Explosion-proof for Class I, Division 1, Groups B, C and D

Dust-ignitionproof for Class II/III, Division 1, Groups E, F and G

Enclosure: Type 4X

Temperature Class: T2

Note 2: Wiring

- All wiring shall comply with Canadian Electrical Code Part 1 and Local Electrical Code.
- In hazardous location, wiring shall be in conduits as shown in the figure.

**WARNING:** SEAL ALL CONDUITS WITHIN 50 cm OF THE ENCLOSURE.  
UN SELLE DOIT ÊTRE INSTALLÉ À MOINS DE 50 cm DU BÎTIER.

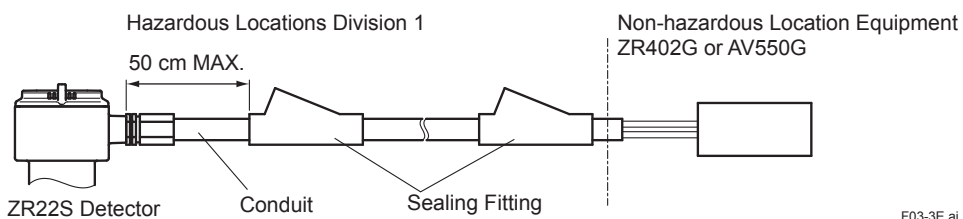

Figure 3.4 Wiring of ZR22S-C

Note 3: Operation

- Keep the “WARNING” label to the Detector.

WARNING: OPEN CIRCUIT BEFORE REMOVING COVER. REFER TO IM 11M13A01-02E. USE AT LEAST 150°C HEAT RESISTANT CABLES.

OUVRIER LE CIRCUIT AVANT D'ENLEVER LE COUVERCLE. UTILISEZ DES CÂBLES RÉSISTANTS À 150°C MINIMUM. VEUILLEZ VOUS RÉFÉRER AU IM 11M13A01-02E.

- Take care not to generate mechanical sparking when accessing to the detector and peripheral devices in hazardous location

Note 4: Maintenance and Repair

- The detector modification or parts replacement by other than authorized representative of Yokogawa Electric Corporation is prohibited and will void Canadian Standards Explosion-proof Certification.

### 3.1.5 IECEx Flameproof Type

ZR22S-D Detector for use in hazardous locations:

Note 1: Applicable Standard: IEC 60079-0: 2011, IEC 60079-1: 2014, IEC 60079-31: 2013

Certificate Number: IECEx KEM 06.0006X

The symbol "X" placed after certificate number indicates that the equipment is subjected to special conditions for safe use. Refer to Note 6.

Type of protection: Ex db IIB+H<sub>2</sub> T2 Gb, Ex tb IIIC T300°C Db

Temperature class for Ex "db": T2

The maximum surface temperature for Ex "tb": T300°C

Degree of protection of enclosure: IP66

Note 2: Wiring

- All wiring shall comply with local installation requirement.

Note 3: Operation

- Keep to "WARNING" on the Detector.

WARNING: DO NOT OPEN WHEN AN EXPLOSIVE GAS ATMOSPHERE IS PRESENT  
POTENTIAL ELECTROSTATIC CHARGING HAZARD-READ USER'S MANUAL (IM11M13A01-02)  
FOR INSTALLATION AND SAFE USE, READ IM11M13A01-02  
USE AT LEAST 150°C HEAT RESISTANT CABLES & CABLE GLANDS

- Take care not to generate mechanical sparking when accessing to the analyzer and peripheral devices in hazardous area.

Note 4: Maintenance and Repair

- The analyzer modification or parts replacement by other than authorized representative of Yokogawa Electric Corporation is prohibited and will void the certification.

Note 5: Cable Entry

- The threaded type of cable entry is marked beside the cable entry according to the following markings.

Threaded type : Marking

M20 × 1.5 : M

1/2 NPT : N

- In case of ANSI 1/2 NPT plug, ANSI hexagonal wrench should be applied to screw in.

- The cable entry devices (cable glands etc.) and blind plugs shall be in type of protection Ex “db” or Ex “tb”, suitable for the conditions of use and correctly installed. They shall provide a degree of ingress protection of at least IP66.

Note 6: Special conditions for safe use

Electrostatic charge may cause an explosion hazard. Avoid any actions that cause the generation of electrostatic charge, such as rubbing with a dry cloth.

If it is mounted in the area where the use of Ex “tb” apparatus is required, it shall be installed in such a way that the risk from electrostatic discharges and propagating brush discharges caused by rapid flow of dust is avoided.

Note 7: Special fastener

Hexagon socket head cap screws below are special fastener according to IEC 60079-0: 2011 (see the figure below). Material property classes of them are A2-50 or better.

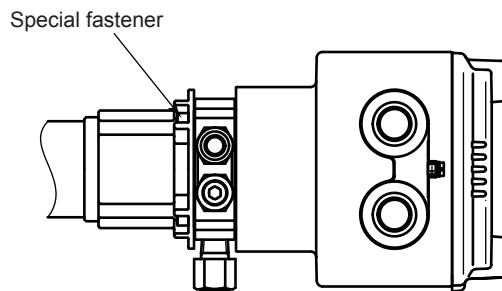

Figure 3.5 Special fastener

### 3.1.6 Probe Insertion Hole

Includes those analyzers equipped with a probe supporter and probe protector.

When preparing the probe insertion hole, the following should be taken into consideration:

#### CAUTION

- The outside dimension of detector may vary depending on its options. Use a pipe that is large enough for the detector. Refer to Figure 3.6 for the dimensions.
- If the detector is mounted horizontally, the calibration gas inlet and reference gas inlet should face downwards.
- The sensor (zirconia cell) at the tip of the detector may deteriorate due to thermal shock if water drops are allowed to fall on it, as it is always at high temperature.

- (1) Do not mount the probe with the tip higher than the probe base.
- (2) The detector probe should be mounted at right angles to the sample gas flow or the probe tip should point downstream.

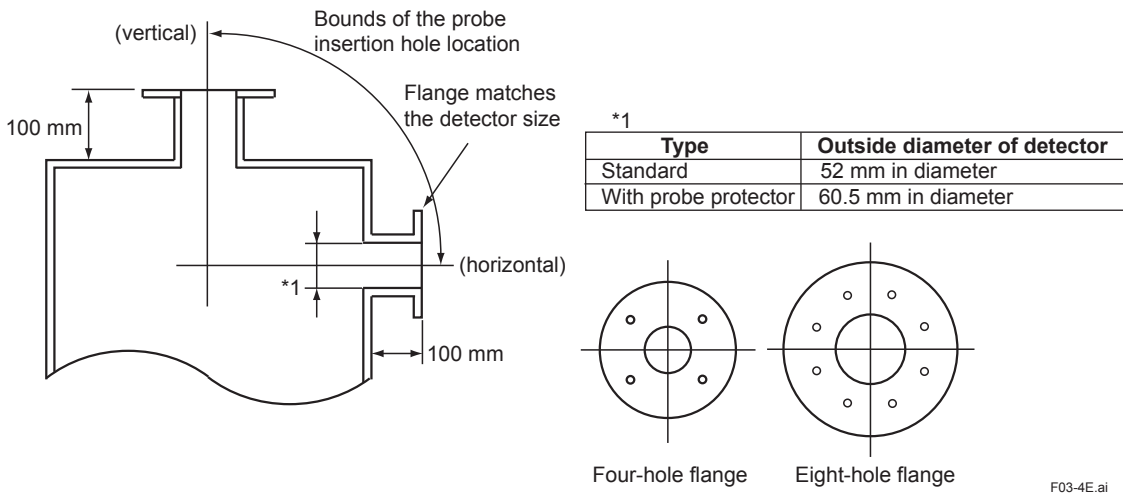

Figure 3.6 Example of forming probe insertion hole

### 3.1.7 Installation of the Detector

#### CAUTION

- The cell (sensor) at the tip of the detector is made of ceramic (zirconia). Do not drop the detector, as impact will damage it.
- A gasket should be used between the flanges to prevent gas leakage. The gasket material should be heatproof and corrosion-proof, suited to the characteristics of the sample gas.

The following should be taken into consideration when mounting the general-purpose detector:

#### <General-purpose detector>

- (1) Make sure that the cell mounting screws (four bolts) at the tip of the detector are not loose.
- (2) Where the detector is mounted horizontally, the calibration gas inlet and the reference gas inlet should face downward.



### 3.1.8 Installation of Probe Protector (ZO21R)

#### <Detector with a probe protector (Model ZO21R-L-□□□-□ \*B dust wear protect>

The detector is used with a probe protector to prevent the sensor from being worn by dust particles when there is a high concentration of dust and gas flow exceeds 10 m/sec (pulverized coal boiler or fluidized-bed furnace).

- (1) Put a gasket (provided by the user) between the flanges, and mount the probe protector in the probe insertion hole. The probe protector should be installed so that the notch is downstream of the sample gas flow.
- (2) Make sure that the sensor assembly mounting screws (four bolts) at the tip of the detector are not loose.
- (3) When the detector mounted horizontally, the reference gas and calibration gas inlet should face downward.

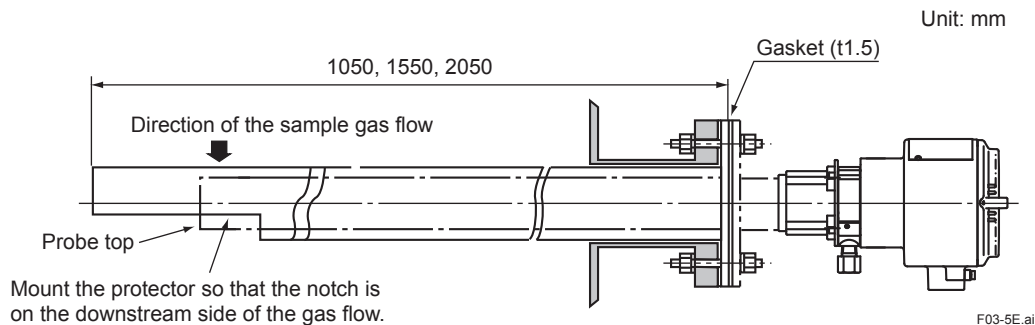

Figure 3.7 Mounting of detector with a probe protector

## 3.2 Installation of High Temperature Detector (Model ZR22S-□-015)

### 3.2.1 Installation Location

This detector is used with the High Temperature Probe Adapter (Model ZO21P) when the temperature of sample gas exceeds 700°C, or when it is required due to maintenance spaces.

The following should be taken into consideration when installing the detector:

- (1) Easy and safe access to the detector for checking and maintenance work.
- (2) Ambient temperature of not more than 60°C and the terminal box should not be exposed to radiant heat.
- (3) A clean environment without any corrosive gases.
- (4) No vibration.
- (5) The sample gas should satisfy the specifications described in Chapter 2.

### CAUTION

Be sure to read Subsection 3.1.2 to 3.1.5 where the important information on writing is provided.

### 3.2.2 Usage of High Temperature Probe Adapter (Model ZO21P)

During analysis, the surface temperature of the probe adapter should be within the range from more than the dew point of the sample gas and 300°C or less to prevent ejector clogging, gasket deterioration or bolt scoring.

Where the dew point of the sample gas is not known, keep within the range of more than 200°C to less than 300°C.

The temperature shall be measured at the probe in the probe adapter and the surface of the blind flange at the opposite side.

When the surface temperature is not within the above range, the following measures can be taken to change the temperature.

### CAUTION

When the surface temperature of ZR22S or ZO21P exceeds temperature class T2(300°C), this system shall not satisfy explosion-proof requirement for outside of the furnace.

#### <When the surface temperature exceeds 300°C>

- (1) When the furnace pressure is negative, lower the pressure setting to reduce induction flow of the sample gas.  
Refer to Subsection 2.7.1, Ejector Assembly for High Temperature, for the setting of induction flow. When you reduce induction flow, ensure that the ejector inducts air when the furnace pressure fluctuates.
- (2) When the furnace pressure is positive, close the needle valve for the sample gas outlet to reduce the exhaust gas flow. Refer to Subsection 4.1.5, Piping to the High Temperature Probe Adapter.
- (3) When the probe adapter is surrounded by a heat insulator, remove the heat insulator. Ensure that the temperature of the probe adapter does not fall below the dew point of the gas in winter.
- (4) To prevent temperature rises due to radiant heat, insert heat insulator between the wall of the furnace and the probe adapter.
- (5) To prevent temperature rises from thermal conduction, place the mounting flange as far from the wall of the furnace as possible.

### CAUTION

When a heater is used in hazardous area, then be sure to use appropriate explosion-proof heater and wiring conduit.

**<When the surface temperature is less than 200°C or below the dew point of the sample gas>**

- (1) When the furnace pressure is negative, raise the pressure setting to increase induction flow of the sample gas.  
Refer to Subsection 2.7.1, Ejector Assembly for High Temperature, for the setting of induction flow.  
If there is much dust in the gas, the ejector may become clogged as induction flow increases.
- (2) When the furnace pressure is positive, open the needle valve of the sample gas outlet to increase the gas flow.  
Refer to Subsection 4.1.5, Piping to the High Temperature Probe Adapter.
- (3) Warm the probe adapter. Refer to Subsection 4.1.5, Piping to the High Temperature Probe Adapter.
- (4) When the surface temperature is still less than 200°C or below the dew point of the sample gas, even if the above measures have been taken, warm the probe adapter using a heat source such as steam.

**3.2.3 Probe Insertion Hole**

A high temperature detector consists of a ZR22S-□-015 Detector and ZO21P High Temperature Probe Adapter. When forming the probe insertion hole, the following should be taken into consideration:

- (1) If the probe is made of silicon carbide (SiC), the probe hole should be formed so that the probe is mounted vertically (within ± 5° tilt).
- (2) In the case where the probe is made of stainless steel and the probe adapter is to be mounted horizontally, the probe hole should be formed so that the probe tip is not higher than the probe base.

Figure 3.8 illustrates examples of the probe insertion hole.

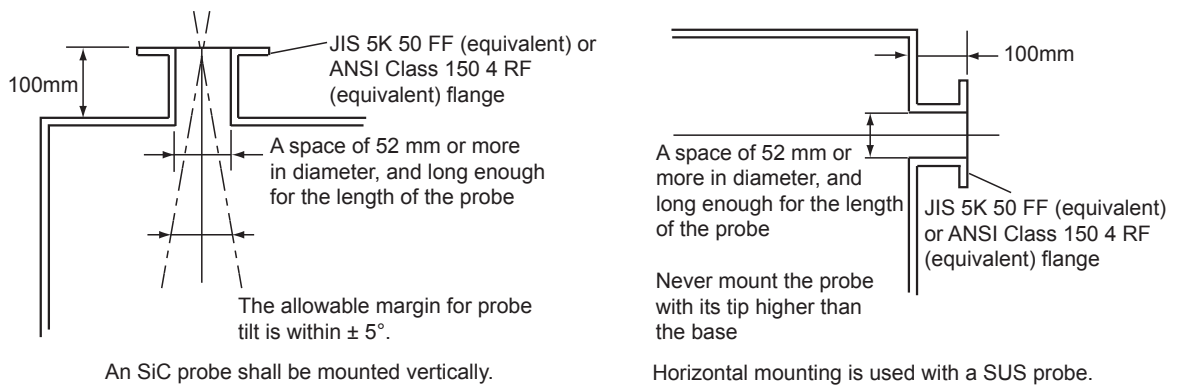

F03-6E.ai

**Figure 3.8 Examples of the probe insertion hole**

### 3.2.4 Mounting of High Temperature Detector

#### CAUTION

- Ceramic (zirconia) is used in the sensor (cell) portion on the detector probe tip. Care should be taken not to drop the detector during installation.
- The same applies to the high temperature probe adapter with a probe made of silicon carbide (SiC).
- A gasket should be used on the flange surface to prevent gas leakage. The gasket material should be selected depending on the characteristics of the measurement gas. It should be heatproof and corrosion-proof. The parts, which should be supplied by the user, are listed in Table 3.1.

**Table 3.1 Accessories for mounting high temperature probe adapter**

Mounting flange specification	Parts name	Q'ty	Note
JIS 5K 50 FF (equivalent)	Gasket	1	Heatproof and corrosion-proof
	Bolt (M12 by 50)	4	
	Nut (M12)	4	
	Washer (for M12)	8	
ANSI Class 150 4RF (equivalent)	Gasket	1	Heatproof and corrosion-proof
	Bolt (M16 by 60)	8	
	Nut (M16)	8	
	Washer (for M16)	16	

A high temperature detector should be mounted as follows:

- (1) It is recommended to mount the detector vertically. When it is impossible due to the physical arrangements and the detector is mounted horizontally, ensure that the probe tip be placed no higher than the probe base.
- (2) When mounting a high temperature probe adapter, be sure to insert a gasket between the flanges to prevent gas leakage. When the furnace pressure is negative, ensure that there is no leakage of air into the detector.
- (3) When mounting the detector in a position other than vertical, the cable inlet should face downward.
- (4) When installing the detector in a low-temperature location such as in the open air, cover the probe adapter including the ejector with a heat insulator (e.g. ceramic wool) to keep it warm and to prevent condensation of drain on the ejector.

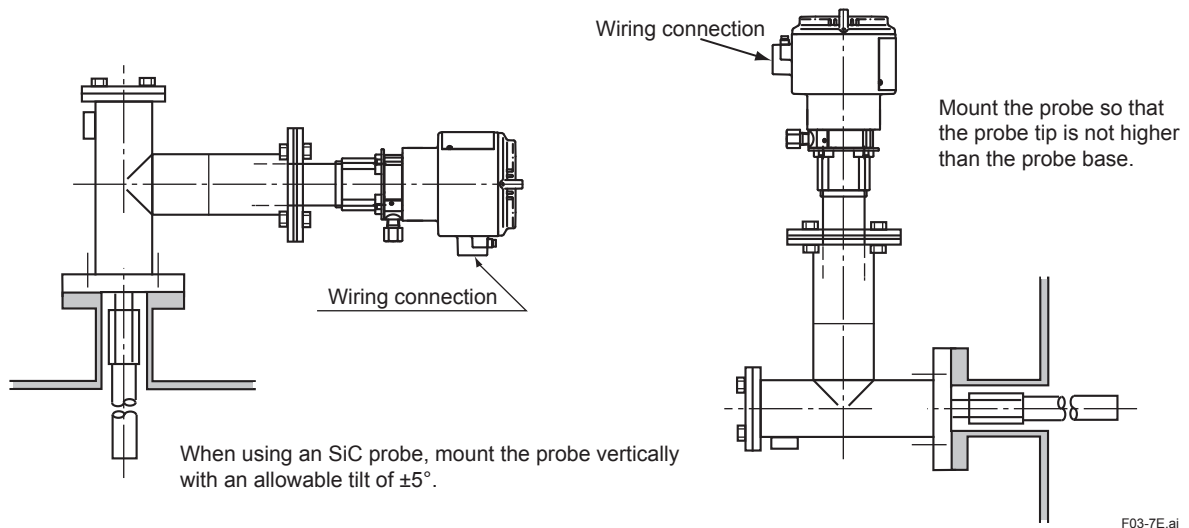

**Figure 3.9 Mounting of the High Temperature Detector**

F03-7E.ai

### 3.3 Installation of ZR402G Converter

**! CAUTION**

Converter (Model ZR402G) must not be located in hazardous area.

#### 3.3.1 Installation Location

The following should be taken into consideration when installing the converter:

- (1) Readability of the indicated values of oxygen concentration or messages on the converter display. Easy and safe access to the converter for operating keys on the panel and for checking and maintenance work.
- (2) An ambient temperature of not more than 55 °C and little change in temperature (recommended within 15 °C in a day).
- (3) The normal ambient humidity (recommended between 40 to 75% RH) and without any corrosive gases.
- (4) No vibration.
- (5) Near to the detector.
- (6) Not in direct rays of the sun. If the sun shines on the converter, prepare the hood (/ H) or other appropriate sunshade.
- (7) Non-hazardous location.

#### 3.3.2 Mounting of the Converter

The converter can be mounted on a pipe (nominal JIS 50A: O.D. 60.5 mm), a wall or a panel. The converter can be mounted at an angle to the vertical, however, it is recommended to mount it on a vertical plane.

Mount the converter as follows.

**<Pipe Mounting>**

- (1) Prepare a vertical pipe of sufficient strength (nominal JIS 50A: O.D. 60.5 mm) for mounting the converter. (Converter weighs approximately 6 kg.)
- (2) Mount the converter on the pipe. Fix it firmly on the pipe in the procedure described in Figure 3.9.

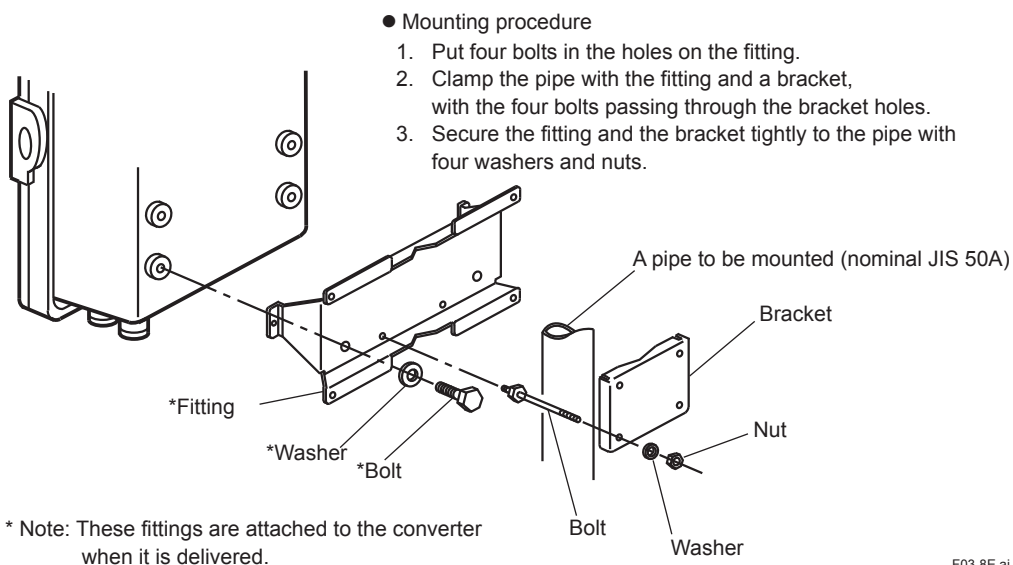

**Figure 3.10 Pipe Mounting**

F03-8E.ai

<Wall Mounting>

(1) Drill mounting holes through the wall as shown in Figure 3.11.

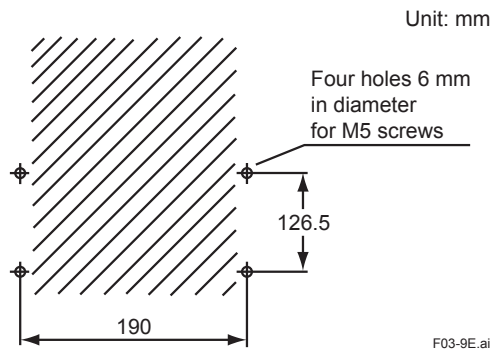

Figure 3.11 Mounting holes

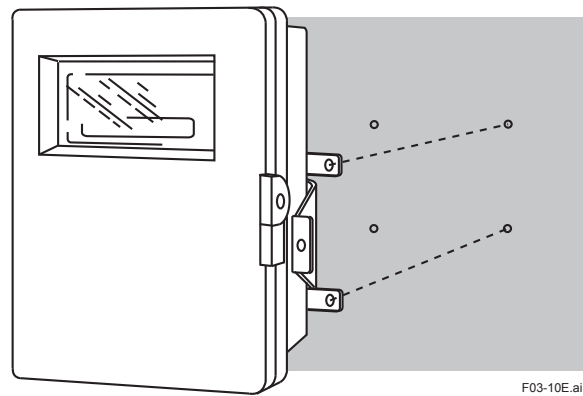

Figure 3.12 Wall Mounting

(2) Mount the converter. Secure the converter on the wall using four screws.

Note: For wall mounting, the bracket and bolts are not used.

<Panel Mounting>

(1) Cut out the panel according to Figure 3.13.

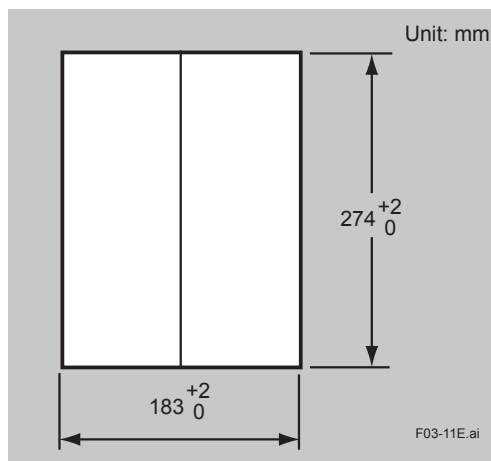

Figure 3.13 Panel cutout sizes

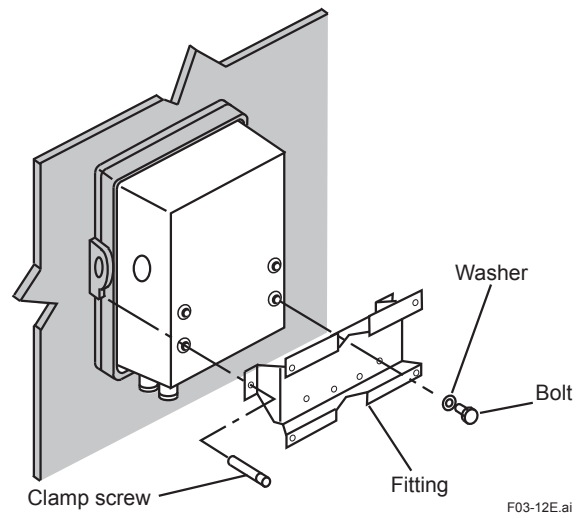

Figure 3.14 Panel mounting

(2) Remove the fitting from the converter by loosening the four screws.

(3) Insert the converter case into the cutout hole of the panel.

(4) Attach the mounting fitting which is once removed in step (2) again to the converter.

(5) Firmly fix the converter to the panel. Fully tighten the two clamp screws to hold the panel with the fitting.

## 3.4 Installation of ZA8F Flow Setting Unit

### 3.4.1 Installation Location

The following should be taken into consideration:

- (1) Easy access to the unit for checking and maintenance work.
- (2) Near to the detector or the converter
- (3) No corrosive gas.
- (4) An ambient temperature of not more than 55 °C and little changes of temperature.
- (5) No vibration.
- (6) Little exposure to rays of the sun or rain.

### 3.4.2 Mounting of ZA8F Flow Setting Unit

The flow setting unit can be mounted either on a pipe (nominal JIS 50A) or on a wall. It should be positioned vertically so that the flowmeter works correctly.

#### <Pipe Mounting>

- (1) Prepare a vertical pipe of sufficient strength (nominal JIS 50A: O.D. 60.5 mm) for mounting the flow setting unit. (The unit weighs approximately 2 to 3.5 kg.)
- (2) Mount the flow setting unit on the pipe by tightening the nuts with the U-bolt so that the metal fitting is firmly attached to the pipe.

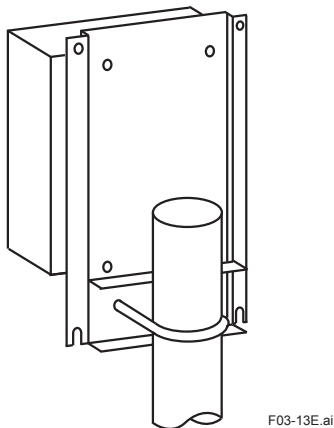

Figure 3.15 Pipe Mounting

#### <Wall Mounting>

- (1) Make a hole in the wall as illustrated in Figure 3.16.
- (2) Mount the flow setting unit. Remove the pipe mounting parts from the mount fittings of the flow setting unit and attach the unit securely on the wall with four screws.

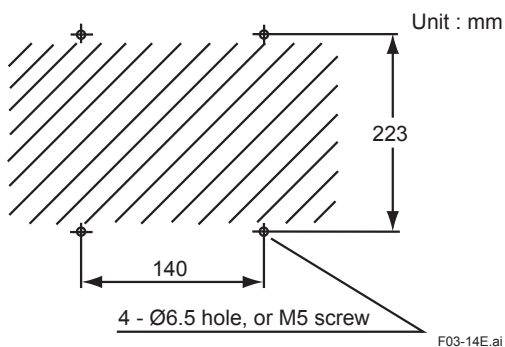

Figure 3.16 Mounting holes

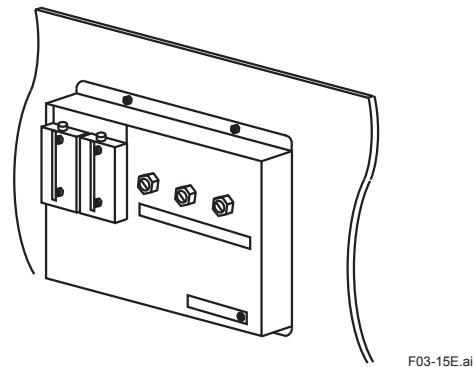

Figure 3.17 Wall mounting

## 3.5 Installation of ZR40H Automatic Calibration Unit

### CAUTION

Automatic Calibration Unit (Model ZR40H) must not be located in hazardous area.

#### 3.5.1 Installation Location

The following should be taken into consideration:

- (1) Easy access to the unit for checking and maintenance work.
- (2) Near to the detector or the converter
- (3) No corrosive gas.
- (4) An ambient temperature of not more than 55 °C and little change of temperature.
- (5) No vibration.
- (6) Little exposure to rays of the sun or rain.
- (7) Non-hazardous location.

#### 3.5.2 Mounting of ZR40H Automatic Calibration Unit

The automatic calibration unit can be mounted either on a pipe (nominal JIS 50 A ) or on a wall. It should be positioned vertically so that the flowmeter works correctly.

##### <Pipe Mounting>

- (1) Prepare a vertical pipe of sufficient strength (nominal JIS 50A: O.D. 60.5 mm) for mounting of automatic calibration unit. (The unit weights approximately 3.5 kg.)
- (2) Mount the automatic calibration unit on the pipe by tightening the nuts with the U-bolt so that the metal fitting is firmly attached to the pipe.

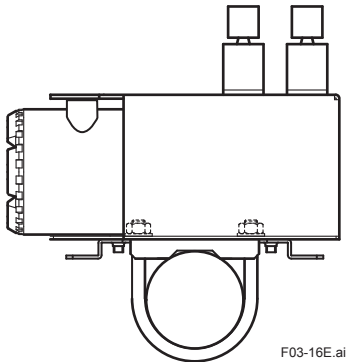
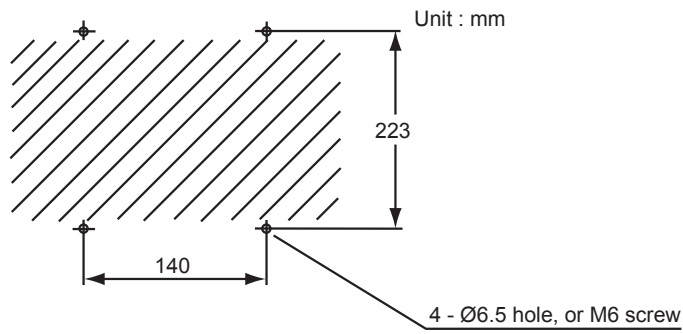

Figure 3.18 Pipe Mounting



<Wall Mounting>

- (1) Make a hole in the wall as illustrated in Figure 3.19.



F03-17E.ai

Figure 3.19 Mounting holes

- (2) Mount the automatic calibration unit. Remove the U-bolt from the automatic calibration unit and attach the unit on the wall with four screws. When setting it with M5 bolts, use washers.

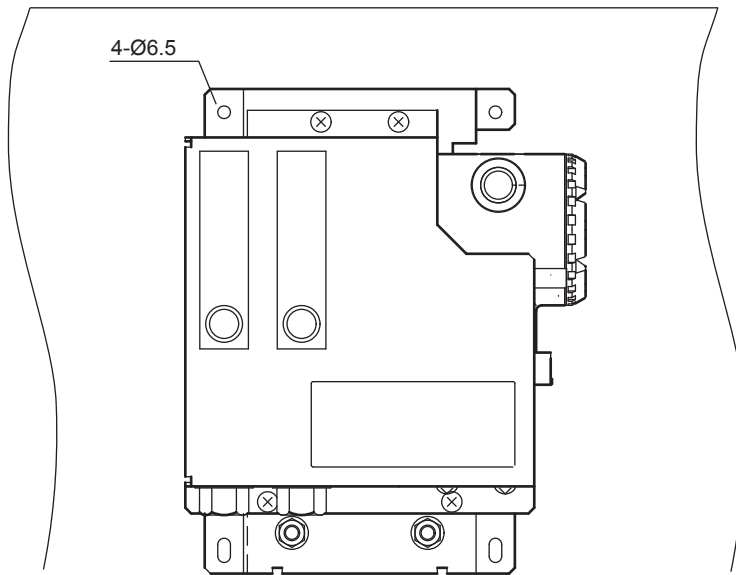

F03-18E.ai

Figure 3.20 Wall Mounting

### 3.6 Insulation Resistance Test

Even if the testing voltage is not so great that it causes dielectric breakdown, testing may cause deterioration in insulation and a possible safety hazard. Therefore, conduct this test only when it is necessary.

The applied voltage for this test shall be 500 V DC or less. The voltage shall be applied for as short a time as practicable to confirm that insulation resistance is 20 MΩ or more.

Remove wiring from the converter and the detector.

1. Remove the jumper plate located between terminal G and the protective grounding terminal.
2. Connect crossover wiring between L and N.
3. Connect an insulation resistance tester (with its power OFF). Connect (+) terminal to the crossover wiring, and (-) terminal to ground.
4. Turn the insulation resistance tester ON and measure the insulation resistance.
5. After testing, remove the tester and connect a 100 kΩ resistance between the crossover wiring and ground, to discharge for over 1 min. During discharge, do not touch the terminal.
6. Testing between the heater terminal and ground, contact output terminal and ground, analog output/input terminal and ground can be conducted in the same manner.
7. Although contact input terminals are isolated, insulation resistance test cannot be conducted because the breakdown voltage of the surge-preventing arrestor between the terminal and ground is low.
8. After conducting all the tests, replace the jumper plate as it was.

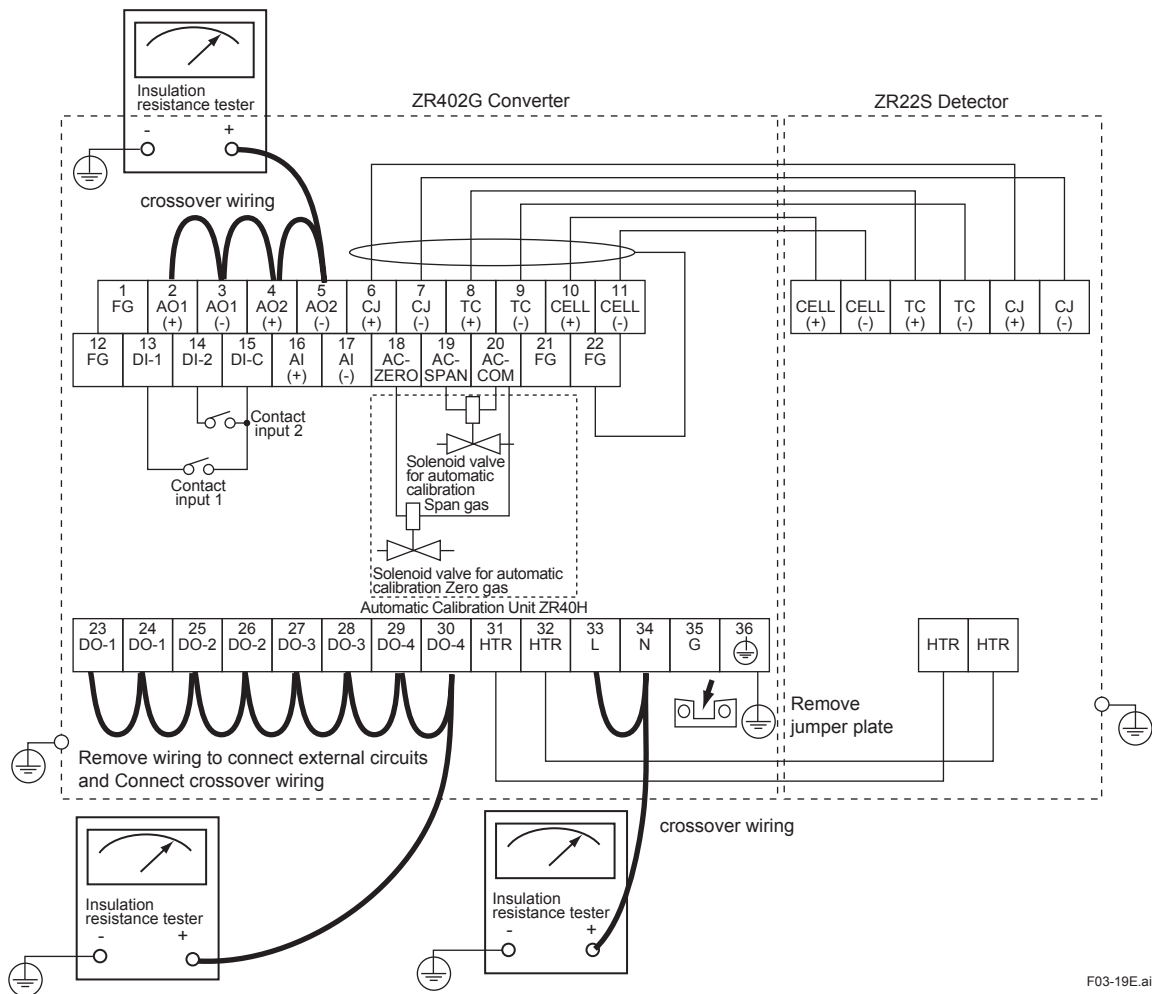

F03-19E.ai



## 4. Piping

This chapter describes piping procedures based on two typical system configurations for EXAxt ZR Separate type Explosion-proof Zirconia Oxygen Analyzer.

- Ensure that each check valve, stop valve and joint used for piping do not allow leakage. Especially, if there is any leakage of the calibration gas from pipes and joints, it may cause clogging of the pipes or incorrect calibration.
- Be sure to conduct leakage test after piping.
- Basically, apply instrument air (dehumidified by cooling to the dew point  $-20^{\circ}\text{C}$  or lower, and removing any dust, oil mist and the like) for the reference gas.

### CAUTION

Do not loosen or remove any Flame Arrestor of gas inlet/outlet during piping.

The detector modification or parts replacement by other than authorized representative of Yokogawa Electric Corporation is prohibited and will void ATEX Certification, FM Approval, CSA Certification and IECEx Certification.

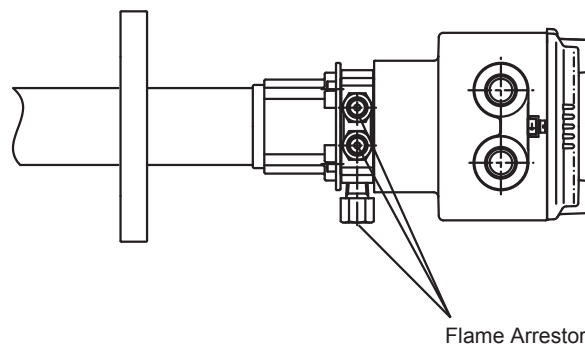

F04E.ai



 **CAUTION**

If a sample gas contains much dust (e.g., in recovery boilers or cement kilns), the probe is more likely to become clogged. To eliminate this dust accumulation using air pressure, piping is generally installed from an air source only when cleaning is performed. Some cases, however, may need a permanent installation of the blow back piping. See Subsection 4.2.5 for the installation of blow back piping.

**4.1.1 Parts Required for Piping in a System Using Flow Setting Units for Manual Calibration**

Referring to Table 4.1, check that the parts required for your system are ready.

**Table 4.1**

Detector	Piping location	Parts Name	Remark	
General-purpose detector	Calibration gas inlet	Stop valve or check valve	Recommended by YOKOGAWA (L9852CB or G7016XH) Provided by YOKOGAWA (K9292DN or K9292DS)	
		Nipple *	R1/4 or 1/4 NPT	General parts
		Zero gas cylinder	User's scope	
		Pressure reducing valve	Recommended by YOKOGAWA (G7013XF or G7014XF)	
		Joint for tube connection	R1/4 or 1/4 NPT	General parts
	Reference gas inlet	Air set	Recommended by YOKOGAWA (G7003XF/K9473XK or G7004XF/K9473XG)	
		Joint for tube connection	R1/4 or 1/4 NPT	General parts
	High temperature detector (0.15 m)	Calibration gas inlet	Stop valve or check valve	Recommended by YOKOGAWA (L9852CB or G7016XH) Provided by YOKOGAWA (K9292DN or K9292DS)
Nipple *			R1/4 or 1/4 NPT	General parts
Zero gas cylinder			User's scope	
Pressure reducing valve			Recommended by YOKOGAWA (G7013XF or G7014XF)	
Joint for tube connection			R1/8 or 1/8 NPT	
Reference gas inlet		Air set	Recommended by YOKOGAWA (G7003XF/K9473XK or G7004XF/K9473XG)	
		Joint for tube connection	R1/4 or 1/4 NPT	General parts
Sample gas outlet		Ejector assembly *	Recommended by YOKOGAWA (E7046EC or E7046EN)	
		T-shaped joint of the same diameter *	Rc1/4 or 1/4 NPT	General parts
		Needle valve *	Rc1/4 or 1/4 NPT	General parts
		Reducing nipple *	R1/2 to R1/4 or R1/2 to 1/4 NPT	General parts

Note: Parts with marking \* are used when required. General parts can be found on the local market.

### 4.1.2 Piping for the Calibration Gas Inlet

This piping is to be installed between the zero gas cylinder and the ZA8F flow setting unit, and between the ZA8F flow setting unit and the ZR22S detector.

The cylinder should be placed in a calibration gas unit case or the like to avoid any direct sunlight or radiant heat so that the gas cylinder temperature does not exceed 40°C. Mount a pressure reducing valve (specified by YOKOGAWA) on the cylinder.

Mount a check valve or stop valve (specified by YOKOGAWA) on the nipple (found on the local market) at the calibration gas inlet of the detector as illustrated in Figure 4.2. (The check valve or the stop valve may have been mounted on the detector when shipped.)

Connect the flow setting unit and the detector to a stainless steel pipe 6 mm (O.D.) × 4 mm (I.D.) or larger (or nominal size 1/4 inch).

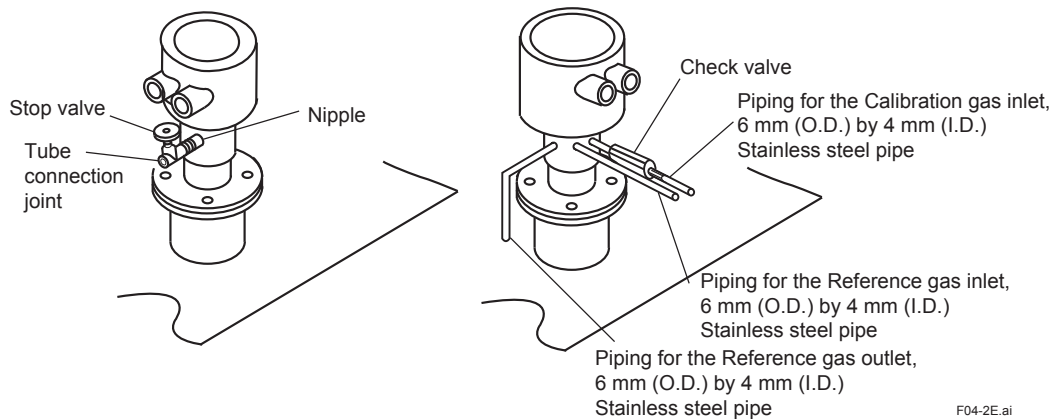

Figure 4.2 Piping for the Calibration Gas Inlet

### 4.1.3 Piping for the Reference Gas Inlet

Reference gas piping is required between the air source (instrument air) and the ZA8F flow setting unit, and between the ZA8F flow setting unit and the ZR22S detector.

Insert the air set next to the flow setting unit in the piping between the air source and the flow setting unit.

Use a 6 mm (O.D.) × 4 mm (I.D.) or larger (or nominal size 1/4 inch) stainless steel pipe between the flow setting unit and the detector.

### 4.1.4 Piping for the Reference Gas Outlet

If the ZR22S is exposed to rain or water splash, connect the pipe outlet on downward.

### 4.1.5 Piping to the High Temperature Probe Adapter

- The sample gas should be at a temperature below 700°C before reaching the detector sensor. If the gas is under negative pressure, it should be fed to the detector by suction.
- For usage of the high temperature probe adapter when using high temperature detector, refer to Subsection 3.2.2.
- If the sample gas is under negative pressure, connect the ejector assembly (E7046EC/ E7046EN) as illustrated in Figure 4.3. Mount the pressure gauge as close as possible to the ejector. However, if the ambient temperature is too high, mount the gauge in a location with a temperature below 40°C.

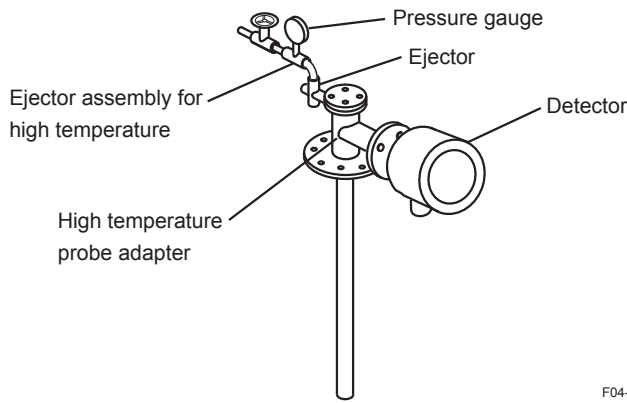

F04-3E.ai

**Figure 4.3** Mounting the ejector assembly

If the temperature of the sample gas is high and its pressure exceeds 0.49 kPa, the temperature of the sample gas at the detector may not be below 700°C. In such a case, connect a needle valve (found on the local market) through a nipple (also found on the local market) to the sample gas outlet (Rc1/2) of the probe adapter so that the sample gas exhaust volume is restricted.

In cases where condensation is likely to occur in the probe adapter when the sample gas is cooled, protect the probe adapter with an insulating material as illustrated in Figure 4.5.

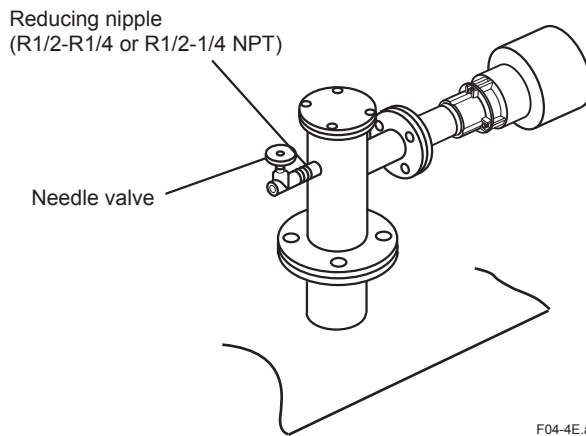

F04-4E.ai

**Figure 4.4** Mounting the needle valve for restricting exhaust flow of the sample gas

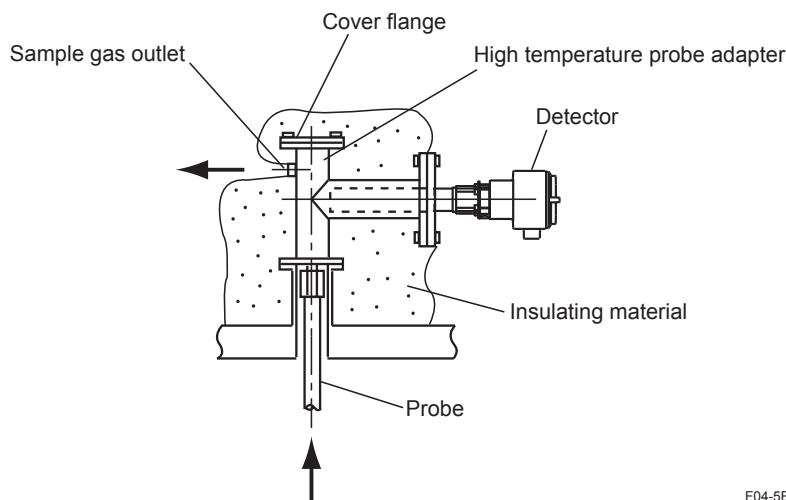

F04-5E.ai

**Figure 4.5** Preventing to condensation



## 4.2 Piping for a System to Perform Automatic Calibration

The piping for a system to perform automatic calibration is shown in Figure 4.6.

The piping is basically the same as that of a system using flow setting unit for manual calibration. Refer to Section 4.1.

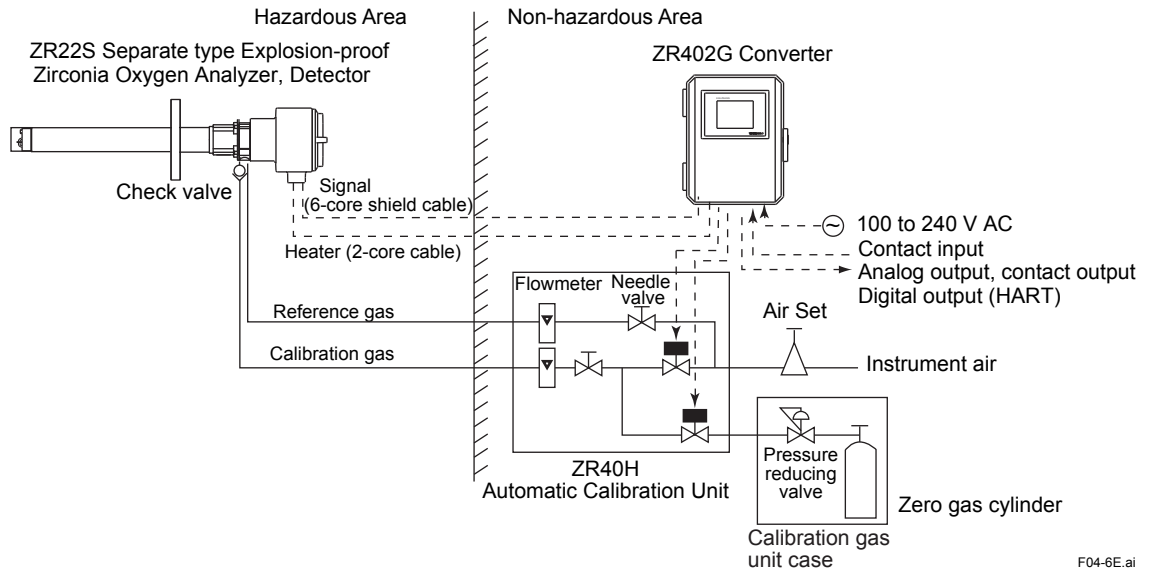

Figure 4.6 Typical Piping for a System to perform Automatic Calibration

F04-6E.ai

### 4.2.1 Parts Required for Piping in a System to Perform Automatic Calibration

Referring to Table 4.2, check that the parts required for your system are ready.

**Table 4.2**

Detector	Piping location	Parts Name	Remark	
General-purpose detector	Calibration gas inlet	Check valve	Recommended by YOKOGAWA (K9292DN or K9292DS)	
		Nipple *	R1/4 or 1/4 NPT	General parts
		Zero gas cylinder	User's scope	
		Pressure reducing valve	Recommended by YOKOGAWA (G7013XF or G7014XF)	
		Joint for tube connection	R1/4 or 1/4 NPT	General parts
	Reference gas inlet	Air set	Recommended by YOKOGAWA (G7003XF/K9473XK or G7004XF/K9473XG)	
		Joint for tube connection	R1/4 or 1/4 NPT	General parts
	High temperature detector (0.15 m)	Calibration gas inlet	Check valve	Recommended by YOKOGAWA (L9852CB or G7016XH) Provided by YOKOGAWA (K9292DN or K9292DS)
Nipple *			R1/4 or 1/4 NPT	General parts
Zero gas cylinder			User's scope	
Pressure reducing valve			Recommended by YOKOGAWA (G7013XF or G7014XF)	
Joint for tube connection			R1/8 or 1/8 NPT	
Reference gas inlet		Air set	Recommended by YOKOGAWA (G7003XF/K9473XK or G7004XF/K9473XG)	
		Joint for tube connection	R1/4 or 1/4 NPT	General parts
Sample gas outlet		Ejector assembly *	Recommended by YOKOGAWA (E7046EC or E7046EN)	
		T-shaped joint of the same diameter *	Rc1/4 or 1/4 NPT	General parts
		Needle valve *	Rc1/4 or 1/4 NPT	General parts
		Reducing nipple *	R1/2 to R1/4 or R1/2 to 1/4 NPT	General parts

Note: Parts with marking \* are used when required. General parts can be found on the local market.

### 4.2.2 Piping for the Calibration Gases

The piping for the calibration gases should be installed between the calibration gas cylinders (or instrument air source) and the detectors with the ZR40H automatic calibration unit.

Figure 4.7 shows the ZR40H Automatic Calibration Unit piping diagram.

Adjust secondary pressure of both the air set and the zero gas pressure reducing valve so that these two pressures are approximately the same. The flow rate of zero and span gases (normally instrument air) are set by a single needle valve.

After installation and wiring, check the calibration contact output (see Subsection 7.11.2), and adjust zero gas pressure reducing valve and calibration gas needle valve so that zero gas flow is within the permitted range. Next check span gas calibration contact output and adjust air set so that span gas flow is within the permitted range.

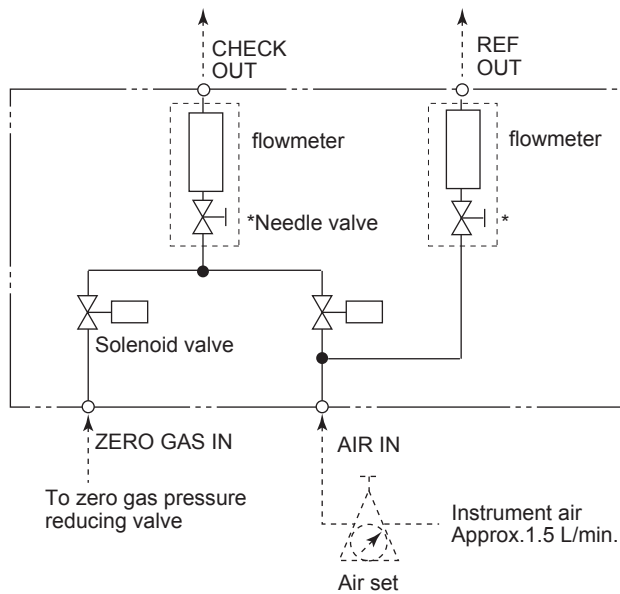

\*: Needle valve is supplied as an accessory with flowmeter F04-7E.ai

**Figure 4.7 ZR40H Automatic Calibration Unit piping diagram**

If the contact input to the converter is used for the blow back function, prepare blow back piping according to Subsection 4.2.5.

### NOTE

Blow back function means the function to get rid of dust inside a probe in a high temperature probe adapter by using compressed air, when a high temperature detector is used.

### 4.2.3 Piping for the Reference Gas

The piping for the reference gas should be installed between the air source (instrument air) and the detector through flowmeters, needle valves of the ZR40H Automatic Calibration Unit.

- Use stainless steel pipes with 6 O.D. x 4 I.D. mm (or nominal 1/4 inch) or larger inside diameter for the piping for the reference gas.

### 4.2.4 Piping to the High Temperature Probe Adapter

The piping to the high temperature probe adapter is required when a high temperature detector is used.

This piping is the same as the one in the system using flow setting unit for manual calibration. See Subsection 4.1.5.

### 4.2.5 Piping for Blow back

This piping is required when the blow back function is carried out. The piping described below provides automatic blow back operation when the “ blow back start “ command is entered to the converter.

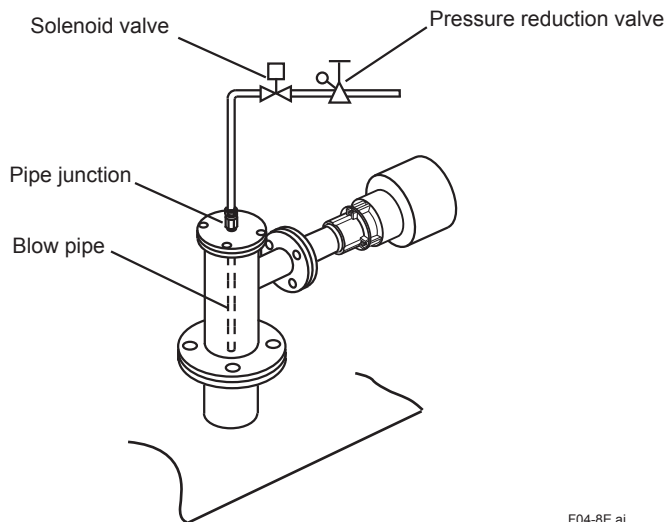

F04-8E.ai

Figure 4.8 Blow back Piping

### CAUTION

When mounting solenoid valves (e.g. used with options like automatic calibration or blow back) in a hazardous area, then be sure to use explosion-proof solenoid valves and appropriate wiring in explosion-proof conduit.

The following parts are required for blow back piping.

- Blow pipe (to be prepared as illustrated in Figure 4.11.)
- Two-way solenoid valve: “ Open “ when electric current is on. (Found on the local market)
- Air set (Yokogawa recommended: G7003XF / K9473XK or G7004XF / K9473XG)

**<Blow pipe manufacturing>**

Manufacture the blow pipe as illustrated in Figure 4.9, and mount it on the high temperature probe adapter.

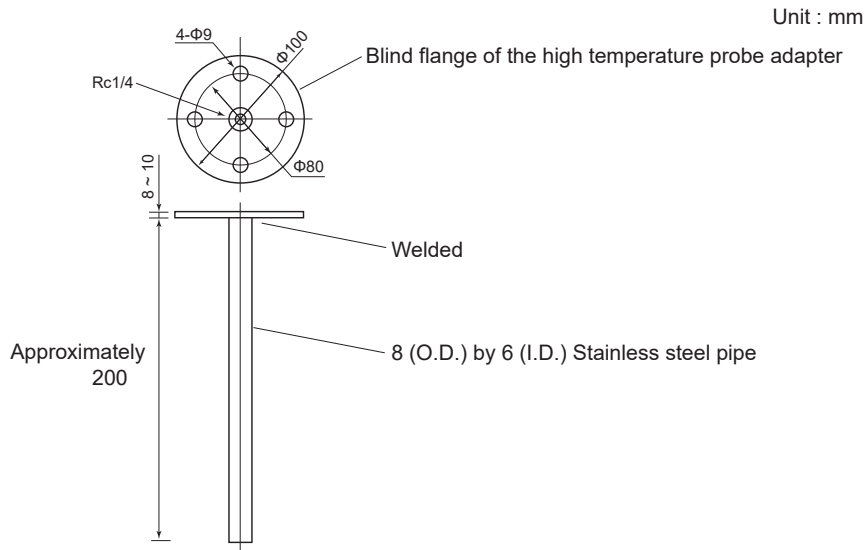

F04-9E.ai

**Figure 4.9 Blow pipe Construction**

# 5. Wiring

In this Chapter, the wiring necessary for connection to the EXAxt ZR Separate type Explosion-proof Zirconia Oxygen Analyzer is described.

## 5.1 General

### CAUTION

- NEVER supply current to the converter or any other device constituting a power circuit in combination with the converter, until all wiring is completed.
  - This product complies with CE marking.  
Where compliance with CE marking is necessary, the following wiring procedure is necessary.
1. Install an external switch or circuit breaker to the power supply of the converter.
  2. Use an external switch or circuit breaker rated 5 A and conforming with IEC 947-1 or IEC 947-3.
  3. It is recommended that the external switch or circuit breaker be mounted in the same room as the converter.
  4. The external switch or circuit breaker should be installed within the reach of the operator, and marked as the power supply switch of this equipment.

### Wiring procedure

Wiring should be performed according to the following procedure:

1. Be sure to connect the shield line to FG terminal of the converter.
2. The outer sheath of the signal line should be stripped to a length of 50 mm or less.  
The most outer sheath of the power cable should be stripped to a length of 20 mm or less.
3. Signals may be affected by noise if signal lines, power cable and heater cable are located in the same conduit. When using conduit, signal lines should be installed in a separate conduit from power and heater cables.
4. Install metal blind plug(s) in unused cable connection gland(s) of the converter.
5. Metal conduit should be grounded.
6. The following cables are used for wiring:

**Table 5.1 Cable specifications**

Terminal name of converter	Name	Need for shields	Number of cores
CELL+, CELL- HTR TC+, HTR TC- CJ+, CJ-	Detector signal	○	6
HEATER	Detector heater		2
L, N	Power supply		2 or 3 *
AO-1+, AO-1-, AO-2+, AO-2-	Analog output	○	2 or 4
DO-1, DO-2, DO-3, DO-4	Contact output		2 to 8
AC-Z, AC-S, AC-C	Automatic calibration unit		3
DI-1, DI-2, DI-C	Contact input		3

Note \*: When the case is used for protective grounding, use a 2-wire cable.

**! WARNING**

Cables that withstand temperatures at least 80°C should be used for wiring.

**! CAUTION**

- Select suitable cable O.D. to match the cable gland size.
- Protective grounding should be connected in ways equivalent to JIS D style (Class 3) grounding (the grounding resistance is 100 Ω or less).
- Special consideration of cable length should be taken for the HART communication, For the detail, refer to Subsection 1.1.2 of the IM 11M12A01-51E “Communication Line Requirements”.

**5.1.1 Terminals for the External Wiring in the Converter**

Open the front door and remove the terminal covering plate to gain access to the converter external wiring terminals (see Figure 5.1).

**! CAUTION**

After wiring necessary cable to the converter terminals, be sure to fix the terminal covering plate with two screws again.

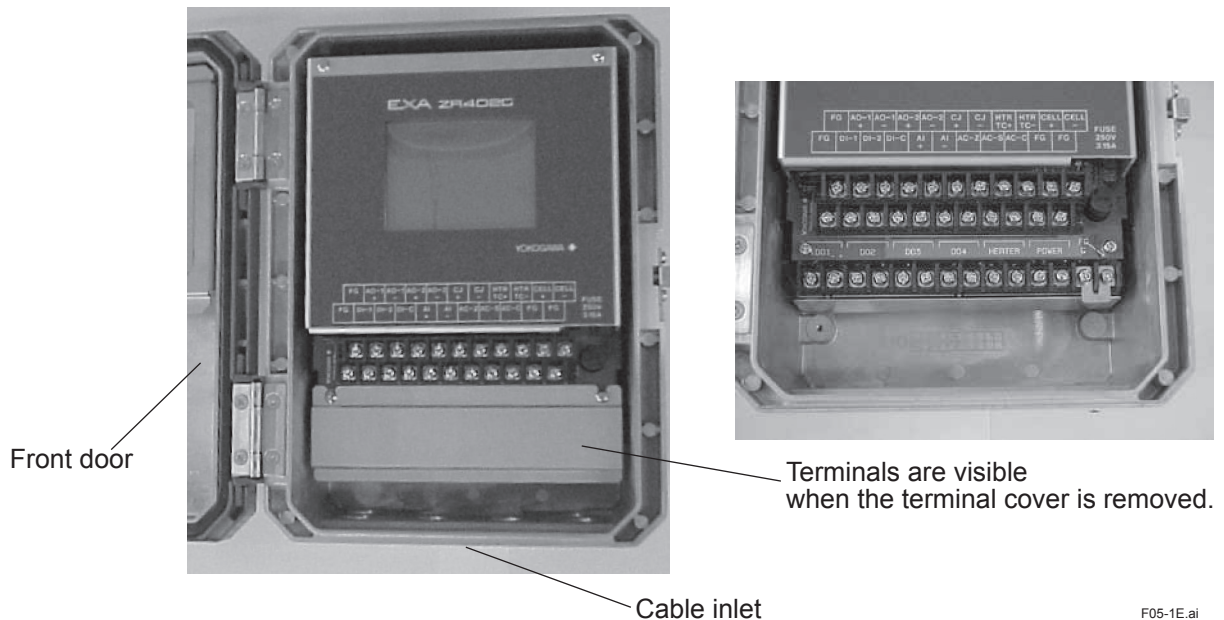
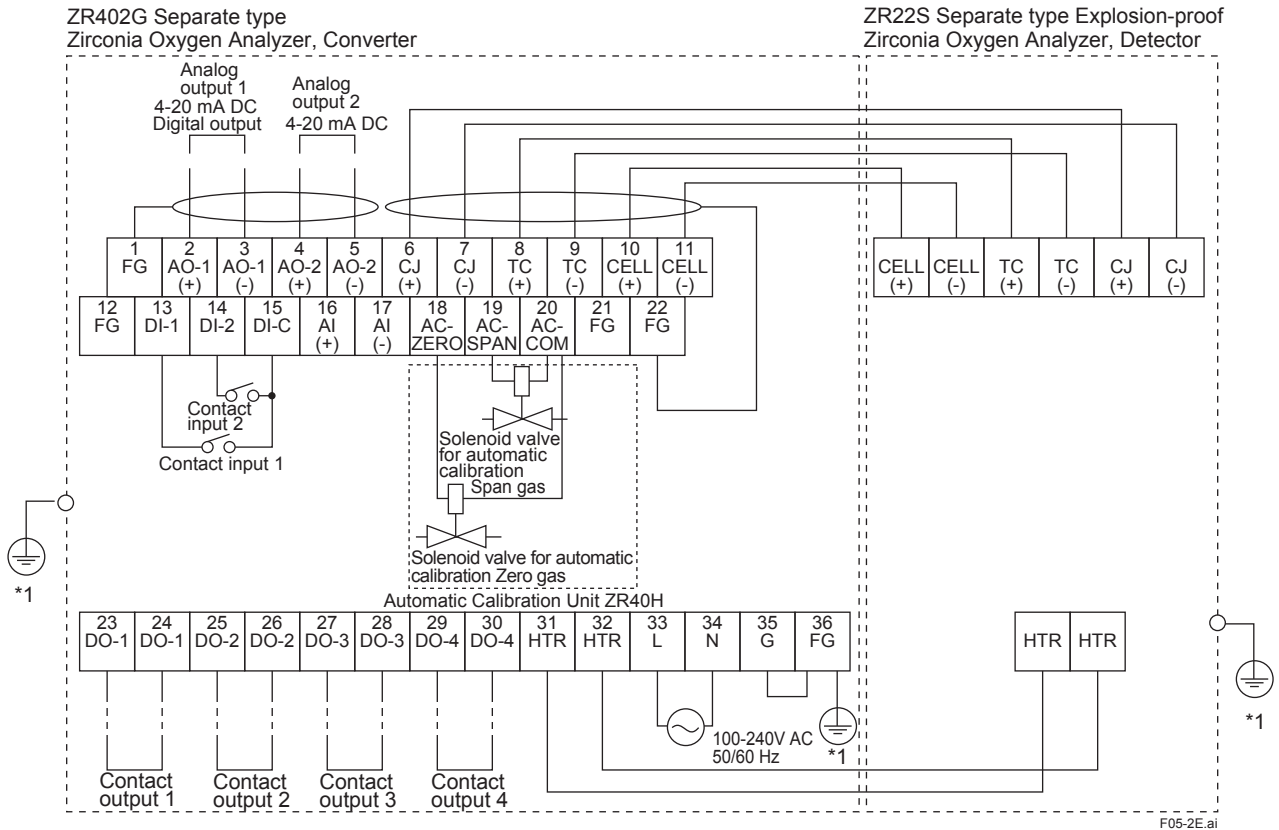

**Figure 5.1** Terminals for external wiring in the converter

### 5.1.2 Wiring

Connect the following wiring to the converter. It requires a maximum of seven wiring connections as shown below.

- (1) Detector output (connects the converter with the detector.)
- (2) Detector heater power (connects the converter with the detector.)
- (3) Analog output signal
- (4) Power and ground
- (5) Contact output
- (6) Operation of the solenoid valve of automatic calibration unit
- (7) Contact input



\*1 The ground wiring of the converter should be connected to either the protective ground terminal in the equipment or the ground terminal of the converter case.  
Ground to earth, ground resistance: 100 Ω or less.

Figure 5.2 Wiring connection to the converter



### 5.1.3 Mounting of Cable Gland

For each cable connection opening of the converter, mount a conduit that matches the thread size, or a cable gland.

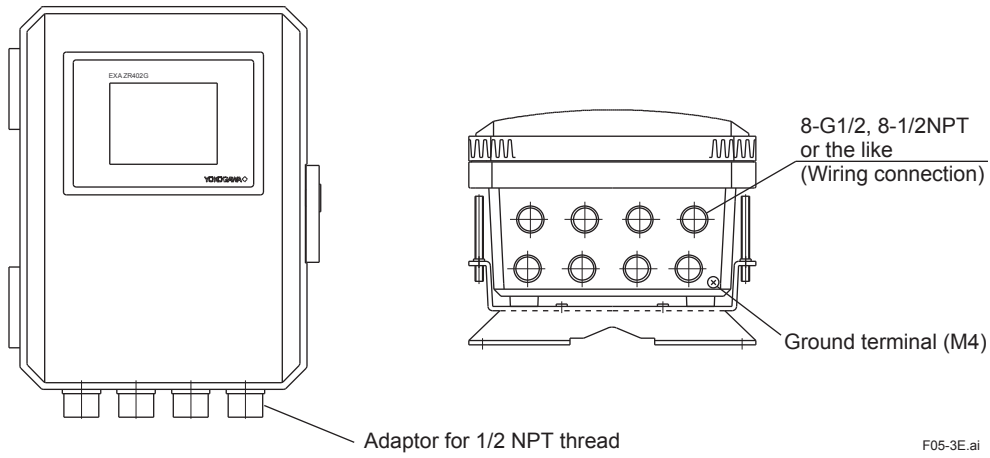

Figure 5.3 Cable gland mounting

F05-3E.ai

## 5.2 Wiring for Detector Output

This wiring enables the converter to receive cell output from the detector, output from a thermocouple and a reference junction compensation signal. Install wires that allow for 10 Ω of loop resistance or less. Keep detector wiring away from power wiring.

### CAUTION

Be sure to read Subsection 3.1.2 to 3.1.5 where the important information on wiring is provided.

- (1) Surface temperature of the detector terminal box: 75°C or less

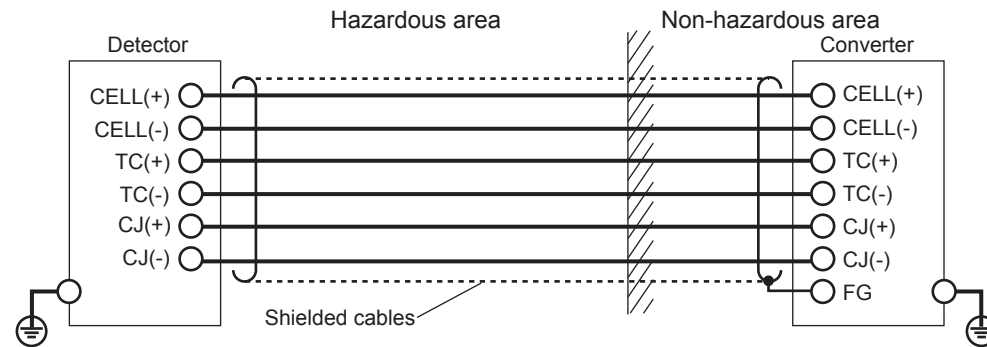

- (2) Surface temperature of the detector terminal box: exceeding 75°C

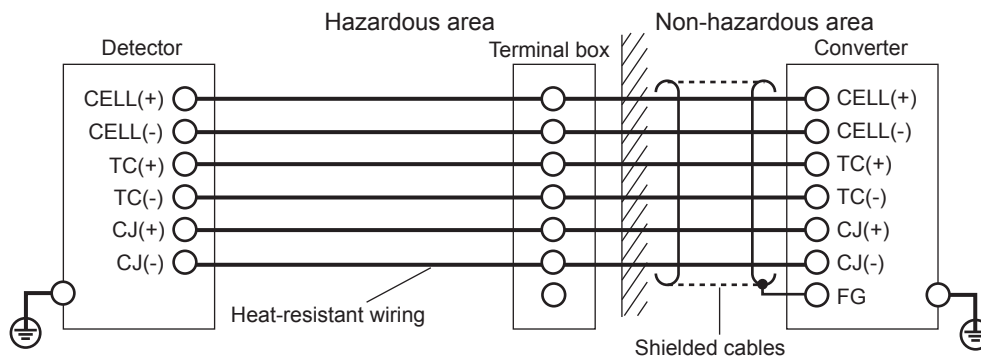

Figure 5.4 Wiring for detector output

### CAUTION

If shielded cables cannot be used between the detector and the terminal box, for example, when heat-resistant wiring is used, locate the detector and the terminal box as close together as possible.

### 5.2.1 Cable Specifications

During operation of the process, the terminal box may get quite hot and may reach temperatures of up to 150°C. The cable may be exposed to even higher temperatures, so be sure to use suitably heat-resistant cable.

Basically, a cable (six core) that withstand temperatures of at least 80°C is used for this wiring. When the ambient temperature of the detector exceeds 75°C, install a terminal box, and connect with the detector using six-piece 600V silicon rubber insulated glass braided wire.

### 5.2.2 Connection to the Detector

To connect cables to the detector, proceed as follows:

- (1) Mount conduits of the specified thread size or cable glands to the wiring connections of the detector. The detector may need to be removed in future for maintenance, so be sure to allow sufficient cable length.
- (2) If the ambient temperature at the location of wire installation is 75 to 150°C, be sure to use a flexible metallic wire conduit. If a non-shielded “600 V silicon rubber insulated glass braided wire” is used, keep the wire away from noise sources to avoid noise interference.
- (3) Figure 5.5 shows the layout of the detector terminals.

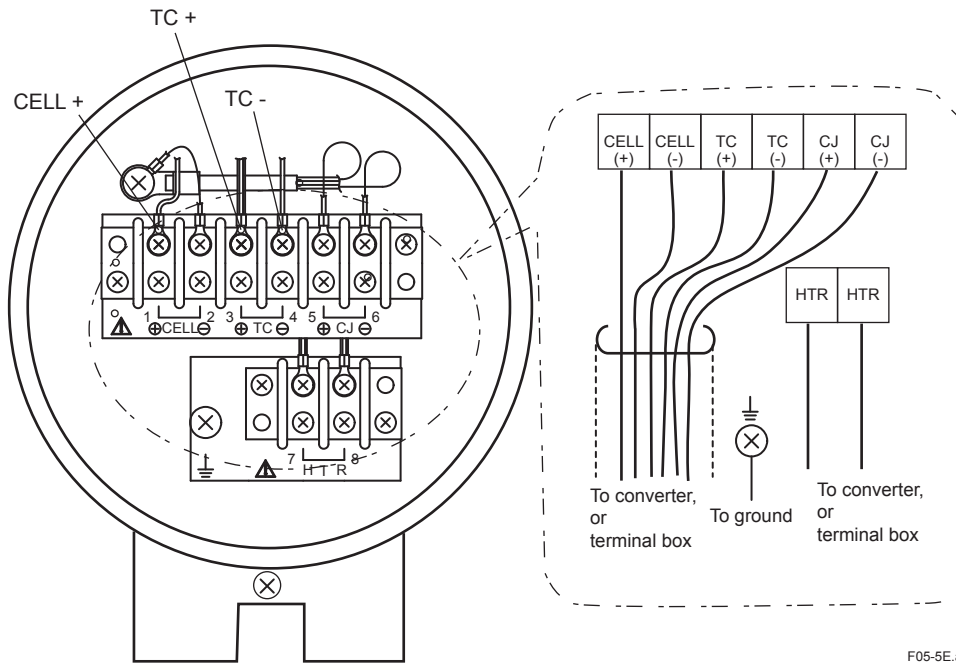

**Figure 5.5** Detector terminals

The sizes of the terminal screw threads are M3.5 except for the M4 on grounding terminal. Each wire in the cable should be terminated in the corresponding size of crimp terminal (\*1) respectively.

\*1: If the surface temperature of the detector terminal box installation site exceeds 60°C, use a “bare crimp-on terminal”.

- (4) Except when “600 V silicon rubber insulated glass braided wire” is used, connect the cable shield to the FG terminal of the converter.

### 5.2.3 Connection to the Converter

To connect the wiring to the converter, proceed as follows:

- (1) M4 screws are used for the terminals of the converter. Each wire in the cable should be terminated corresponding to crimp-on terminals.
- (2) When a rubber insulated glass braided wire is used for wiring to the detector, use a terminal box. For wiring between the terminal box and the converter, basically use a cable that withstand temperatures of at least 80°C, rather than individual wires.

### NOTE

The above is to prevent moisture or corrosive gas from entering the converter and to ground the detector without fail.

### 5.3 Wiring for Power to Detector Heater

This wiring provides electric power from the converter to the heater for heating the sensor in the detector.

**! CAUTION**

Refer to section 3.1.

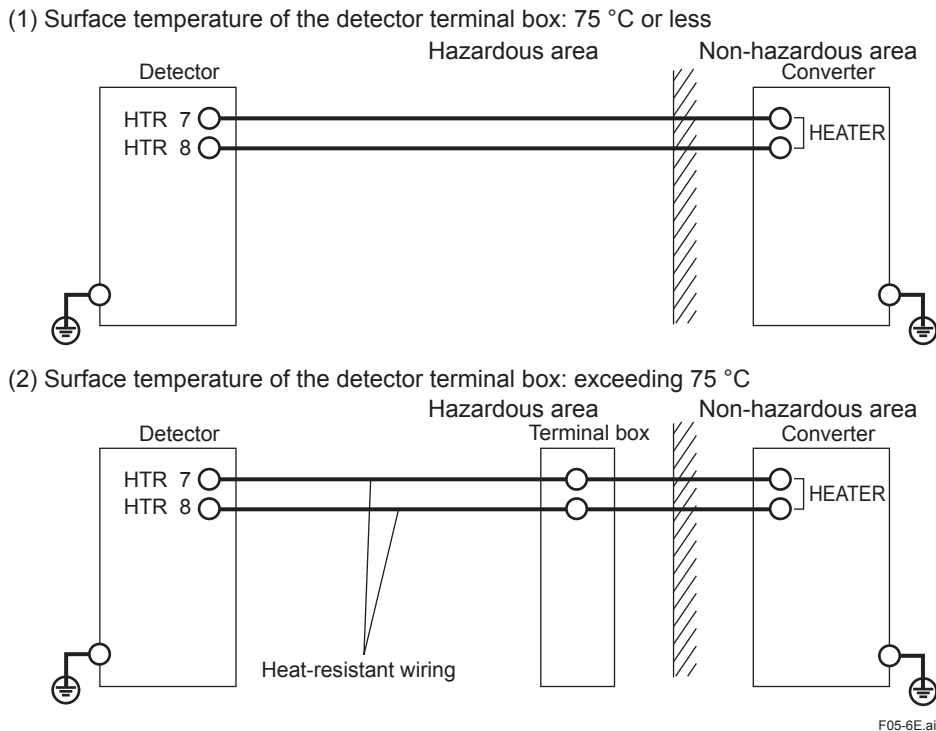

Figure 5.6 Wiring for power to detector heater

#### 5.3.1 Cable Specifications

Basically, cables (2 cores) that withstand temperatures of at least 80°C are used for this wiring. When the ambient temperature of the detector exceeds 75°C, install a terminal box, and connect to the detector using six-piece 600 V silicon rubber insulated glass braided wires.

#### 5.3.2 Connection to Detector

When connecting the cable to the detector, proceed as follows:

- (1) Mount cable glands or conduits of the specified thread size to the wiring connections of the detector. The detector may need to be removed in future for maintenance, so be sure to allow sufficient cable length.
- (2) If the ambient temperature at the location of wire installation is 75 to 150°C, be sure to use a flexible metallic conduit for the wire. If a non-shielded “600 V silicon rubber insulated glass braided wire” is used, keep the wire away from noise sources to avoid noise interference.
- (3) The size of the terminal screw threads is M3.5. Each cable should be terminated in the corresponding size crimp-on terminals contact (\*1) respectively.

\*1 If the surface temperature of the detector terminal box installation site exceeds 60 °C, use a “bare crimp-on terminal”.

---

**!** **CAUTION**

- Before opening the detector cover, loosen the lock screw. If the screw is not loosened first, the screw will damage the cover, and the terminal box will require replacement. When opening and closing the cover, remove any sand particles or dust to avoid gouging the thread.
  - Notice when closing the cover of the detector  
After screwing the cover in the detector body, secure it with the lock screw.
- 

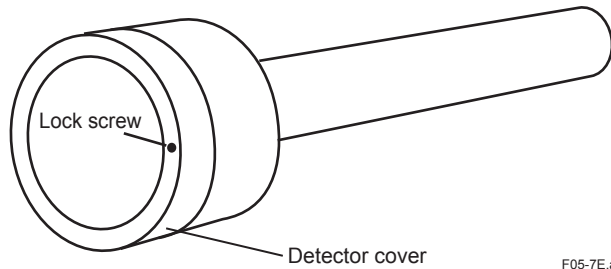

Figure 5.7 Detector

F05-7E.ai

### 5.3.3 Connection to Converter

To connect the wiring to the converter, proceed as follows:

- (1) M4 screws are used for the terminals of the converter. Each cable should be terminated in the corresponding size crimp-on terminals.
- (2) When a rubber insulated glass braided wire is used for wiring to the detector, use a terminal box. For wiring between the terminal box and the converter, basically use a cable that withstand temperatures of at least 80°C, rather than wire.

---

**!** **CAUTION**

The above is to prevent moisture or corrosive gas from entering the converter. Where the ambient environment of the detector and the converter is well-maintained, it is permissible to connect the wiring from the detector directly to the converter with protection by conduits.

---

**!** **WARNING**

This wiring is to carry power for the heater. Be careful to wire the correct terminals, and be careful not to ground or short circuit terminals when wiring, as otherwise the instrument may be damaged.

---

## 5.4 Wiring for Analog Output

This wiring is for transmitting 4 to 20 mA DC output signals to a device, e.g. recorder. Maintain the load resistance including the wiring resistance at 550 Ω or less.

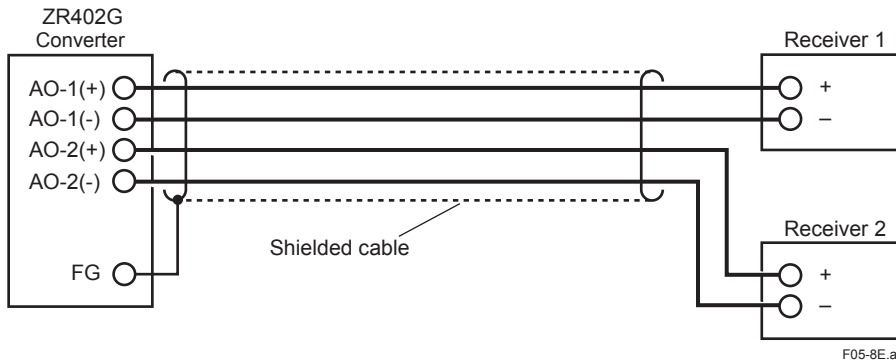

Figure 5.8 Wiring for analog output

### 5.4.1 Cable Specifications

For this wiring, use a 2-core or a 4-core shielded cable.

### 5.4.2 Wiring Procedure

- (1) M4 screws are used for the terminals of the converter. Each wire in the cable should be terminated corresponding to crimp-on terminals. Ensure that the cable shield is connected to the FG terminal of the converter.
- (2) Be sure to connect “+” and “-” polarities correctly.

## 5.5 Power and Grounding Wiring

This wiring supplies power to the converter and grounds the converter/detector.

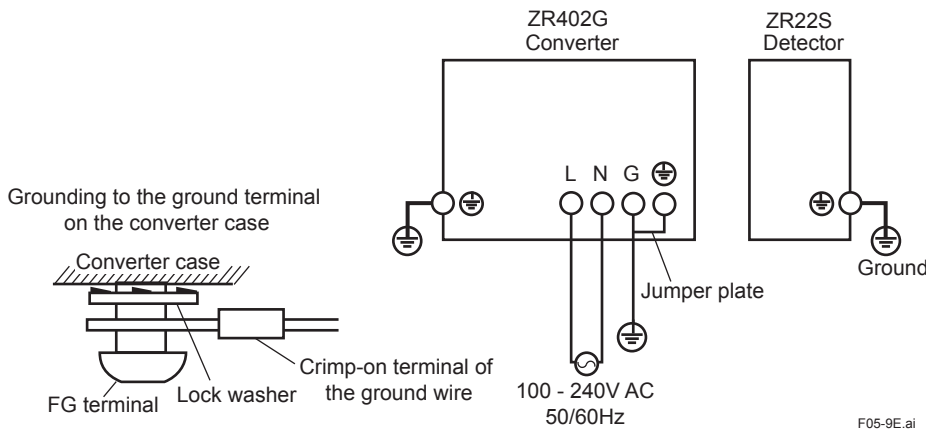

Figure 5.9 Power and Grounding wiring

### 5.5.1 Power Wiring

Connect the power wiring to the L and N terminals of the converter. Proceed as follows:

- (1) Use a 2-core or a 3-core cable.
- (2) The size of converter terminal screw threads is M4. Each wire in the cable should be terminated corresponding to crimp-on terminals.

### 5.5.2 Grounding Wiring

The ground wiring of the detector should be connected to the ground terminal of the detector case. The ground wiring of the converter should be connected to either the ground terminal of the converter case or the protective ground terminal in the equipment. The grounding terminals of the detector are of size of M4 (inside) and M5 (outside), and the grounding terminals of the converter are of size M4. Proceed as follows:

- (1) Keep ground resistance to 100 Ω or less.
- (2) When the ambient temperature of the wiring installation is 75 to 150°C for the wiring of the detector, use wiring material with sufficient heat resistance.
- (3) When connecting the ground wiring to the ground terminal of the converter case, be sure that the lock washer is in contact with the case surface (see Figure 5.9.).
- (4) Ensure that the jumper plate is connected between the G terminal and the protective ground terminal of the converter.
- (5) No intermediate parts are used for the internal ground terminal of the detector. Use crimping terminal for connection to the internal ground terminal in order to avoid corrosion by high contact potentials.
- (6) In order to prevent the earthing conductor from loosening, the conductor must be secured to the terminal, tightening the screw with torque of approx. 1.2 N•m (for M4) or 2.0 N•m (for M5).
- (7) Care must be taken not to twist the conductor.

## 5.6 Contact Output Wiring

Contact outputs 1 to 3 can be freely assigned to “low limit alarm”, “high limit alarm”, etc. user selectable, but the assignment of contact output 4 is fixed (“error output”). And the action (contact closed on error output) also cannot be changed.

When using these contact outputs, install the wiring as follows:

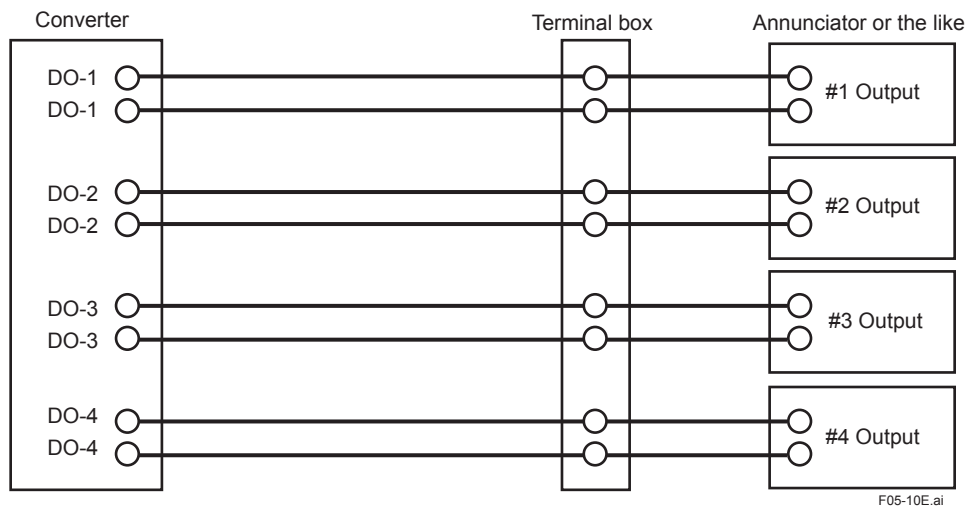

Figure 5.10 Contact output wiring

### 5.6.1 Cable Specifications

Number of wire in cable varies depending on the number of contact used.

### 5.6.2 Wiring Procedure

- (1) M4 screws are used for the terminals of the converter. Each wire in the cable should be terminated corresponding to crimp-on terminals.
- (2) The capacities of the contact output relay are 30V DC 3 A, 250V AC 3 A. Connect a load (e.g. pilot lamp and annunciator) within these limits.

## 5.7 Wiring for ZR40H Automatic Calibration Unit

This wiring is for operating the solenoid valve for the zero gas and the span gas in the ZR40H Automatic Calibration Unit, in a system where the calibration gas flow rate is automatically controlled (e.g. System configuration 2). When installing this wiring, proceed as follows:

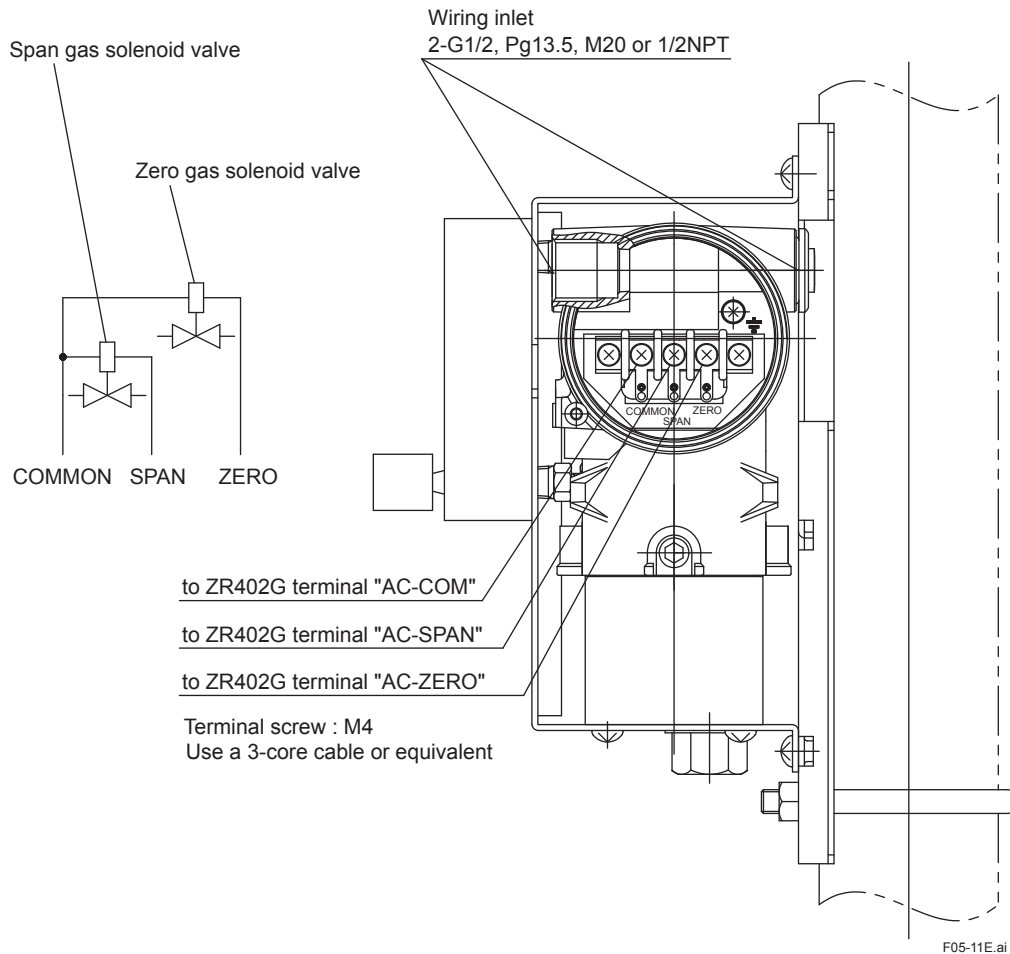

Figure 5.11 Automatic Calibration Unit

### 5.7.1 Cable Specifications

Use a 3-core cable for the above wiring.



### 5.7.2 Wiring Procedure

M4 screws are used for the terminals of the converter. Each wire in the cable should be terminated corresponding to crimp-on terminals. M4 screws are used for the terminals of the solenoid valve as well.

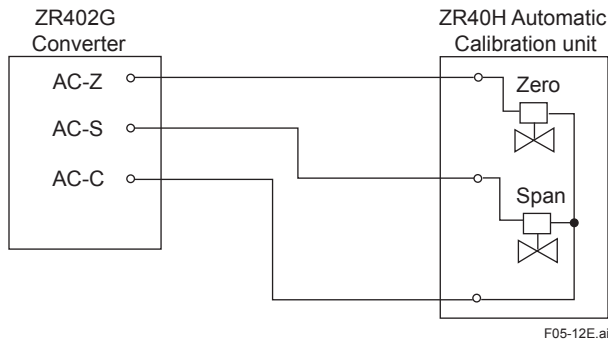

Figure 5.12 Wiring for Automatic Calibration Unit

## 5.8 Contact Input Wiring

The converter can execute specified function when receiving contact signals. To use these contact signals, proceed wiring as follows:

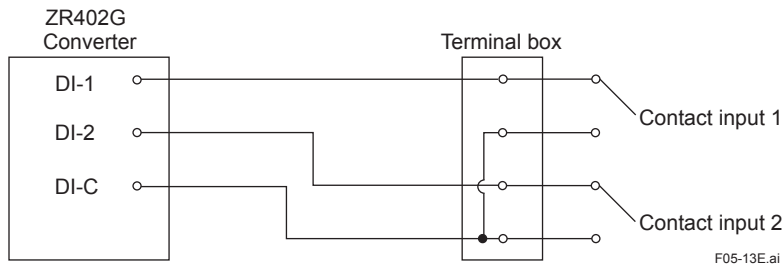

Figure 5.13 Contact Input Wiring

### 5.8.1 Cable Specifications

Use 2-core or 3-core cable for this wiring. Depending on the number of input(s), determine which cable to use.

### 5.8.2 Wiring Procedure

- (1) M4 screws are used for the terminals of the converter. Each wire in the cable should be terminated corresponding to crimp-on terminals.
- (2) The ON/OFF level of this contact input is identified by the resistance. Connect a contact input that satisfies the specifications in Table 5.2.

Table 5.2 Identification of Contact Input ON/OFF

	Closed	Open
Resistance	200 Ω or less	100 kΩ or more

# 6. Components and Their Functions

In this Chapter, the names and functions of components are described for the major equipment of the EXAxt ZR Separate type Explosion-proof Zirconia Oxygen Analyzer.

## 6.1 ZR22S Detector

### 6.1.1 General-purpose Explosion-proof Detector (except for ZR22S-□-015)

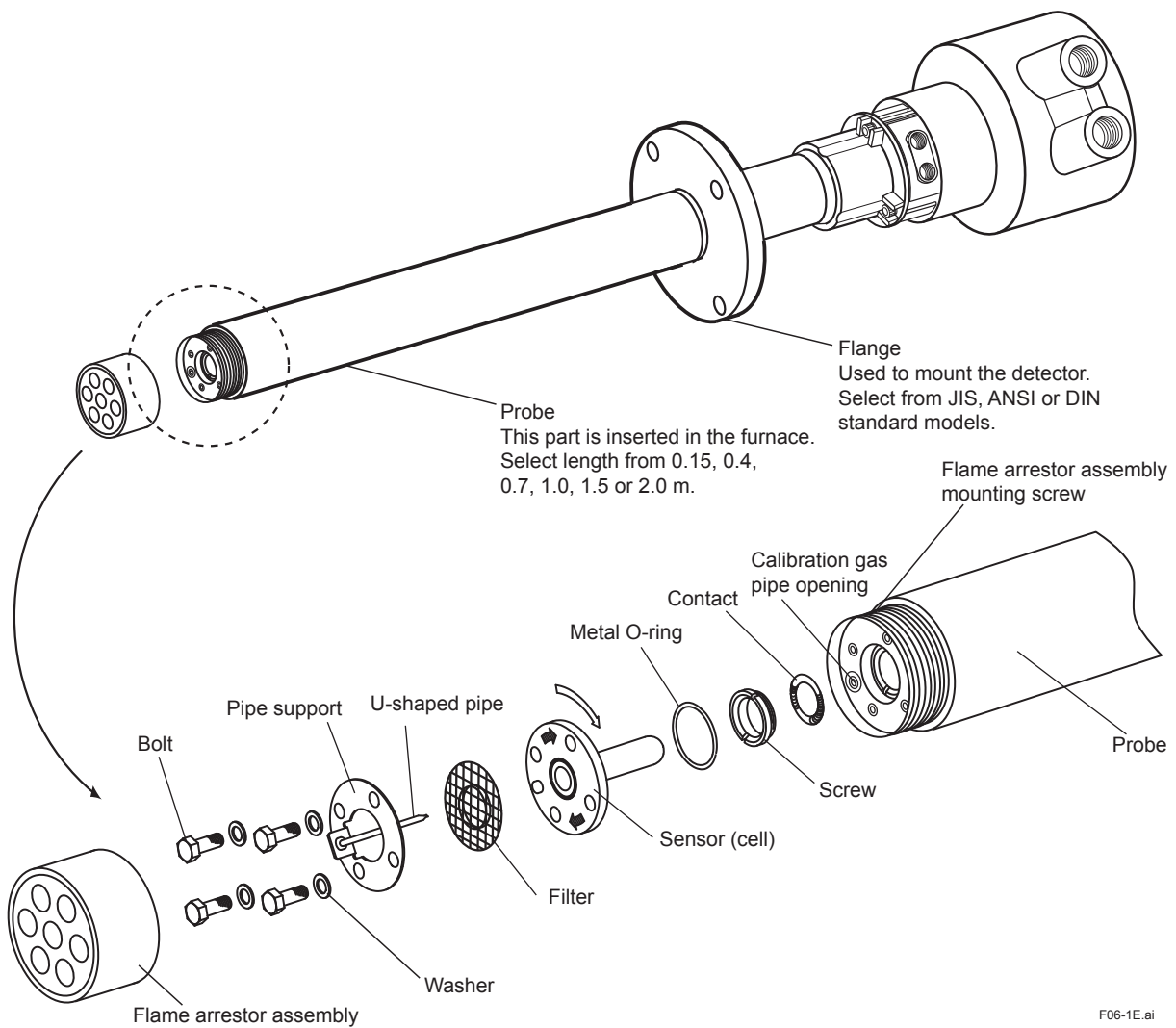

F06-1E.ai

Figure 6.1 General-purpose Explosion-proof Detector (Standard type)

### 6.1.2 High Temperature Detector (ZR22S-□-015)

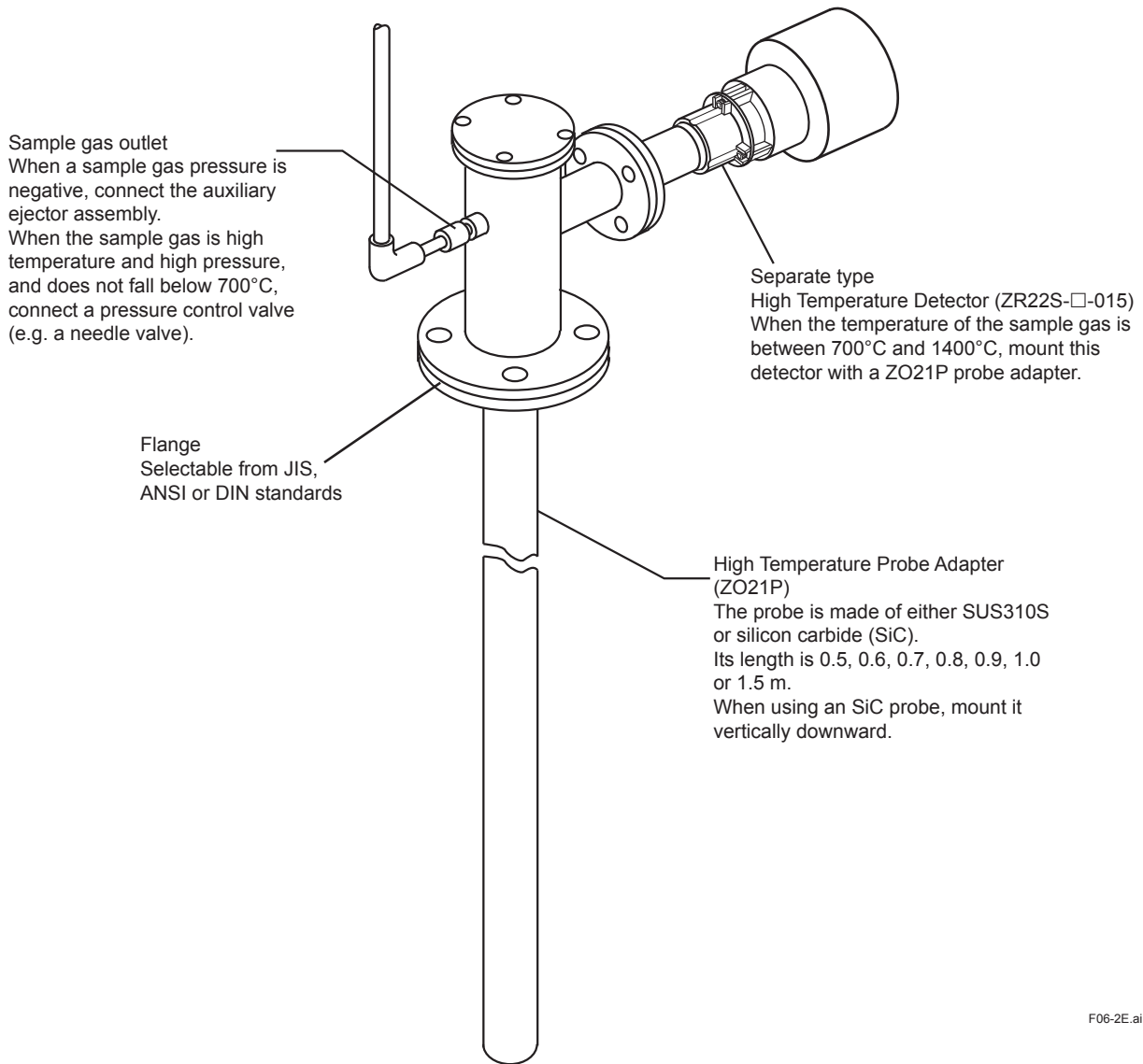

F06-2E.ai

Figure 6.2 High Temperature Detector

## 6.2 ZR402G Converter

### Complete Operation Display

- Interactive operations along with operation display.
- A variety of display modes - enabling you to select the operation mode freely.
- Back-lit LCD allows viewing even in the darkness.
- Error codes and details of errors can be checked in the field without the need to refer to appropriate instruction manual.
- Password for security



Self-testing suggests countermeasures for problems

If a problem occurs, the liquid-crystal display will provide an error code and description of the problem. This enables prompt and appropriate corrective action to be taken.

Error code	Reason for error
Error 1	Cell failure
Error 2	Abnormal heater temperature
Error 3	Defective A/D converter
Error 4	Faulty EEPROM
Alarm 1	Abnormal oxygen concentration
Alarm 2	Abnormal moisture
Alarm 3	Abnormal mixing ratio
Alarm 6	Abnormal zero calibration ratio
Alarm 7	Abnormal span calibration ratio
Alarm 8	Stabilization time over

Figure 6.3 Converter

**Touch Screen Display**

- **Example of basic display**

This data display provides for interactive operation.

- **Example of trend display — displays data changes**

During calibration, you can check the stabilized, display data while viewing oxygen trend data, thus providing highly reliable calibration.

- **Example of setting data display**

**Commissioning**

- ☞ Basic setup
- ◆ mA-output setup
- ◆ Alarms setup
- ◆ Contact setup
- ◆ Others

- One-touch interactive display operation
- User-friendly design providing easy operation without having to use the instruction manual

F06-3E.ai

## 6.3 Touchpanel Switch Operations

### 6.3.1 Basic Panel and Switch

The converter uses a touchpanel switch which can be operated by just touching the panel display. Figure 6.4 shows the Basic panel display. The switches that appear in the switch display area vary depending on the panel display, allowing all switch operations. Table 6.1 shows the switch functions.

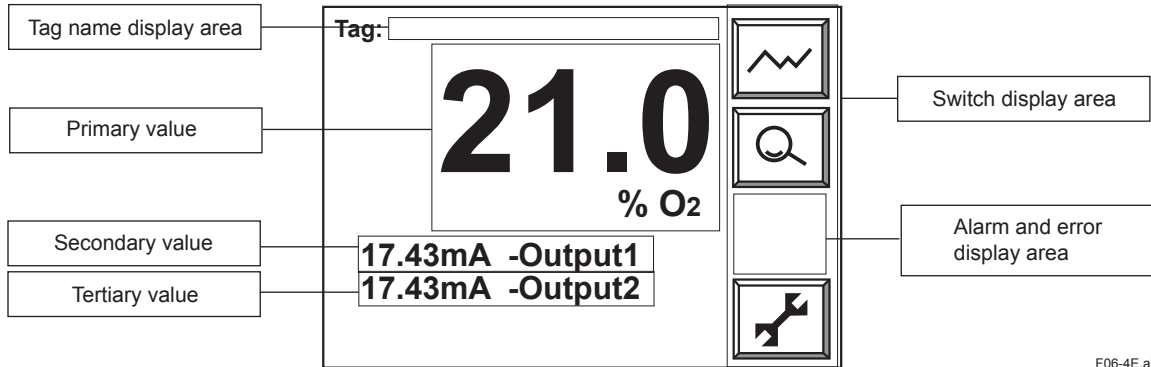

F06-4E.ai

Figure 6.4 Basic Panel Display

Tag name display area: Displays the set tag name (Refer to Subsection 10.3.2, Entering Tag Name).

Primary to tertiary value: Displays the selected item. (Refer to Section 7.9, Setting Display Item.)

Switch display area: Displays switches and functions selected according to the panel display.

Alarm and error display area: Displays an error if an alarm or error occurs. If you touch this area, the details of the error or alarm are then displayed.

Table 6.1 Switches and Their Functions

	Home key: Returns to the Execution/Setup display.		Enter key: Enters the input value and sets up the selected item.
	Reject key: Moves back to the previous display.		Setup key: Used to enter the Execution/Setup display.
	Cursor key: Moves the cursor down.		Detailed-data key: Displays the analog input value.
	Graph display key: Displays a trend graph.		Cursor: Points the cursor at the currently selected item.
	Alarm: Displayed if an alarm arises.		Error: Displayed if an error occurs.

T06-1E.ai

### 6.3.2 Display Configuration (for Oxygen Analyzer)

Figure 6.5 shows the configuration. A password the displays positioned below enables display "Execution/Setup" to be protected. If a password has not been set, press the [Enter] key to proceed to the next panel display. The [Home] key enables you to return to Execution/Setup from any panel display.

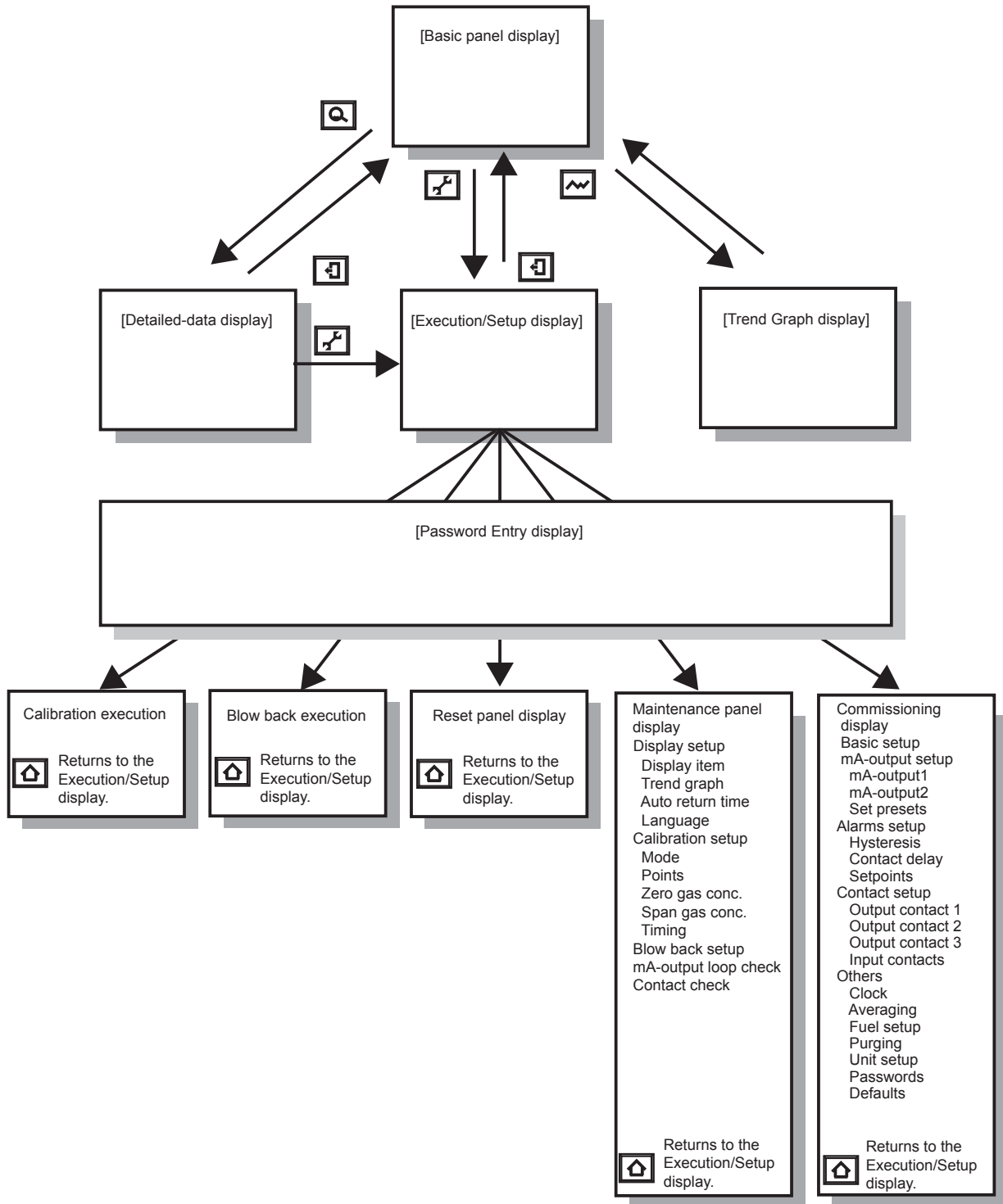

F06-5E.ai

Figure 6.5 Display Configuration

### 6.3.3 Display Functions

Individual panel displays in the display configuration provide the following functions:

- (1) Basic panel display: Displays the values measured in three selected items. (see Section 7.9, "Setting Display Item").
- (2) Execution/Setup display: Selects the calibration, maintenance and setup items.
- (3) Detailed-data display: This allows you to view such detailed data as the cell electromotive force and cell temperature. (see Section 10.1, "Detailed-data Display", later in this manual).
- (4) Trend Graph display: Displays a trend graph. (see Section 10.2, "Trend Graph", later in this manual).
- (5) Calibration execution: Makes zero and span calibrations. (see Chapter 9, "Calibration", and the associated sections later in this manual).
- (6) Blow back execution: Executes a "Blow back setup". (see Section 10.4, "Blow Back", later in this manual).
- (7) Reset panel display: If an error arises, you can restart the equipment from this display. (for more details, see Section 10.6, "Reset", later in this manual).
- (8) Maintenance panel display: Sets the data for equipment maintenance or makes a loop check.
- (9) Commissioning display: Sets up the operation data. (For details, see Chapter 8, "Detailed Data Setting", and the associated sections later in this manual.)

### 6.3.4 Entering Numeric and Text Data

This section sets out how to enter numeric and text data. If only numeric values are entered, a numeric-data entry display as in Figure 6.6 then appears. Press the numeral keys to enter numeric values. If those values include a decimal point as in Figure 6.6, the decimal point need not be entered because the decimal point position is already fixed, so just enter 00098.

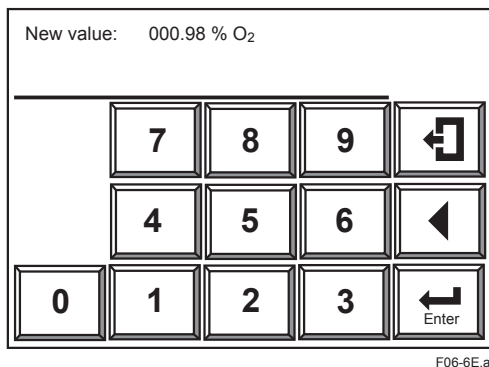

**Figure 6.6** Numeric-data Entry Display

To enter a password (in combination with text data, numeric values and codes), the alphabetic character entry panel display first appears. If you press any numeral key [0 - 9], the current display then changes to the numeric-value entry panel display, enabling you to enter numeric values. If you press the [other] key, the current display then changes to the code-entry display, enabling you to enter codes. These displays alternate between the three. Figure 6.7 shows the relationship between these three displays. Three alphabetic characters and three codes are assigned for each individual switch. If the alphabetic character key is pressed and held, three characters appear in turn. Move the cursor to the desired character and release the key to enter it. If an incorrect character is entered, move the cursor to re-enter the characters. The following shows an example of entering "abc%123."

Operation  
 Press the [ABC] key once.  
 Press and hold the [ABC] key.

Display  
 A\_  
 AA  
 B → C

Release the [ABC] key when the character B appears in the cursor position.  
 Enter the character C in the same manner as above.  
 Press the [other] key.

AB\_  
 ABC\_

Press and hold the [\$%&] key and enter “%.”  
 Then press the [0-9] key.

ABC%\_

Enter the numeric characters 1, 2 and 3 in turn.  
 Press the [Enter] key to complete the entry.

ABC%123\_

Siki06E.ai

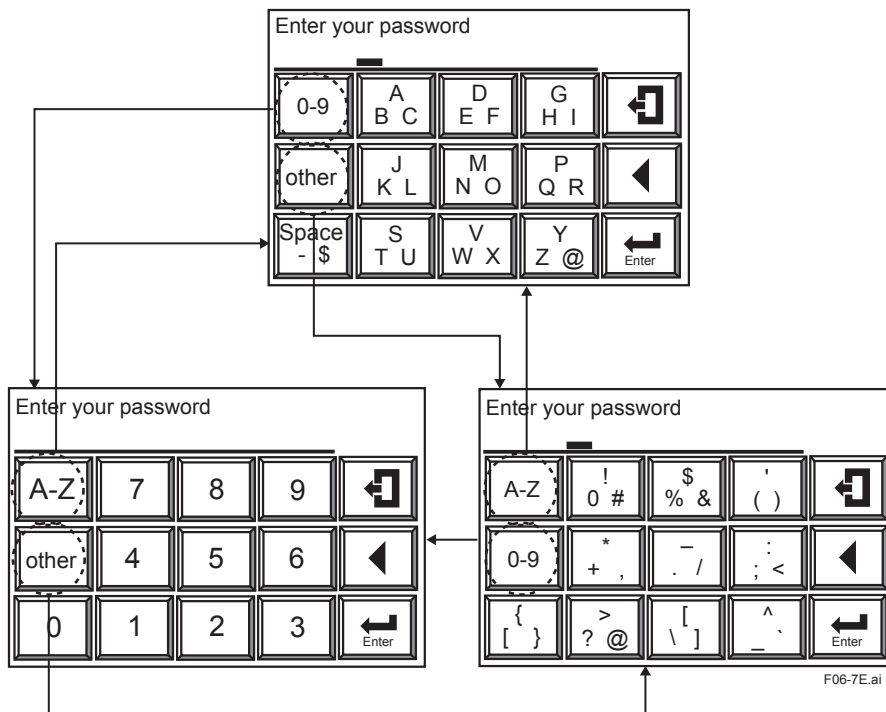

F06-7E.ai

Figure 6.7 Text Entry Display



# 6.4 ZA8F Flow Setting Unit, ZR40H Automatic Calibration Unit

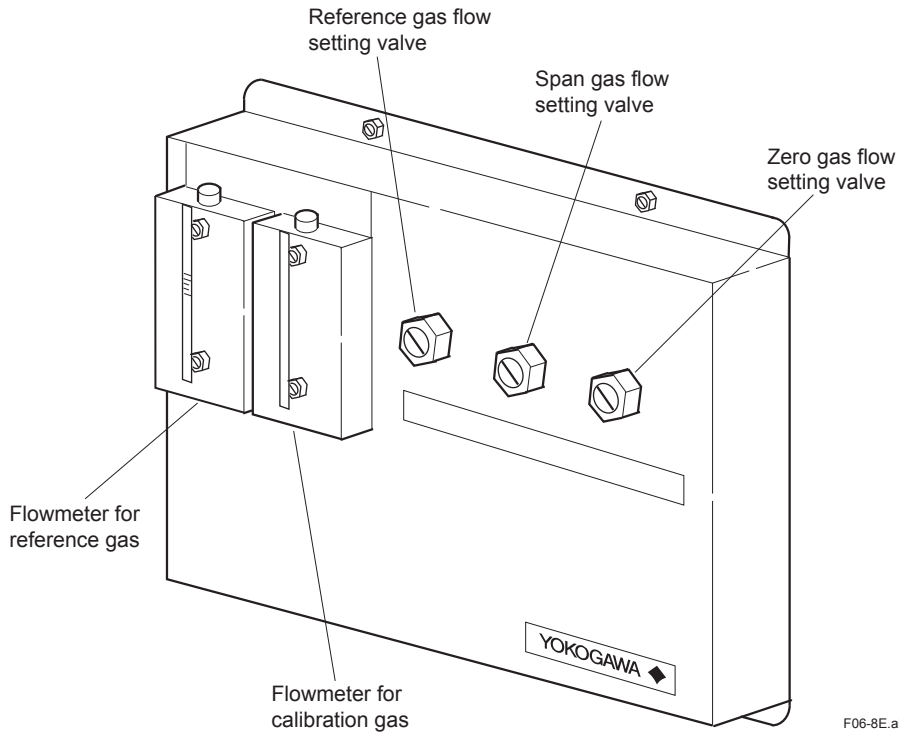

F06-8E.ai

Figure 6.8 ZA8F Flow Setting Unit

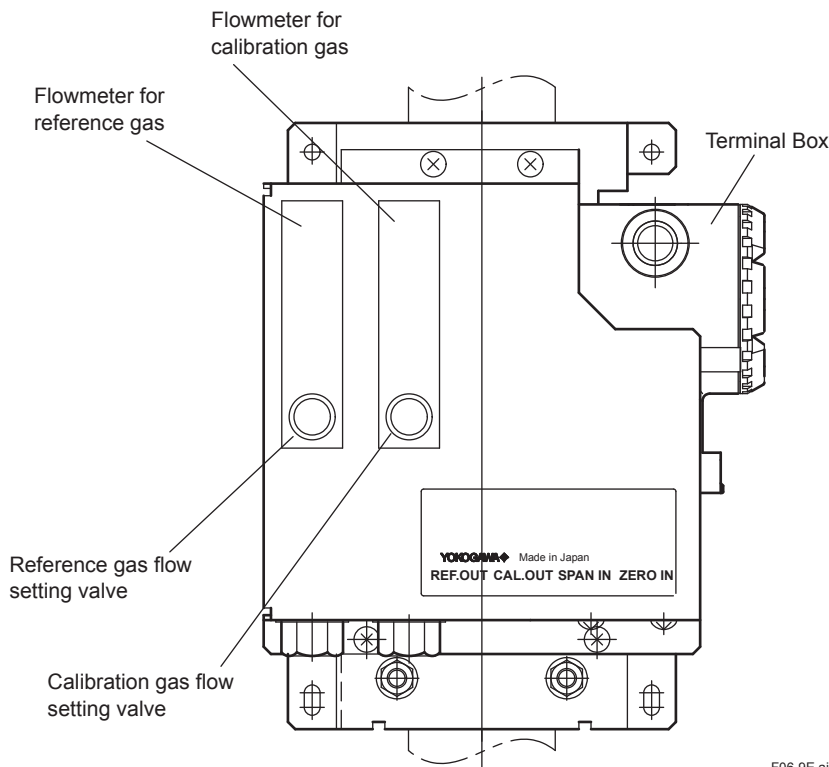

F06-9E.ai

Figure 6.9 ZR40H Automatic Calibration Unit

# 7. Startup

The following describes the minimum operating requirements — from supplying power to the converter to analog output confirmation to manual calibration.

System tuning by the HART communicator, refer to IM11M12A01-51E “HART Communication Protocol”.

## 7.1 Startup Procedure

The startup procedure is as follows:

### CAUTION

If you connect Model ZO21D\* detectors, then you need to change the detector parameters. Before connecting power, refer to: Section 7.6 Confirmation of Detector Type Setting.

\* The ZO21D is not a explosion-proof detector.

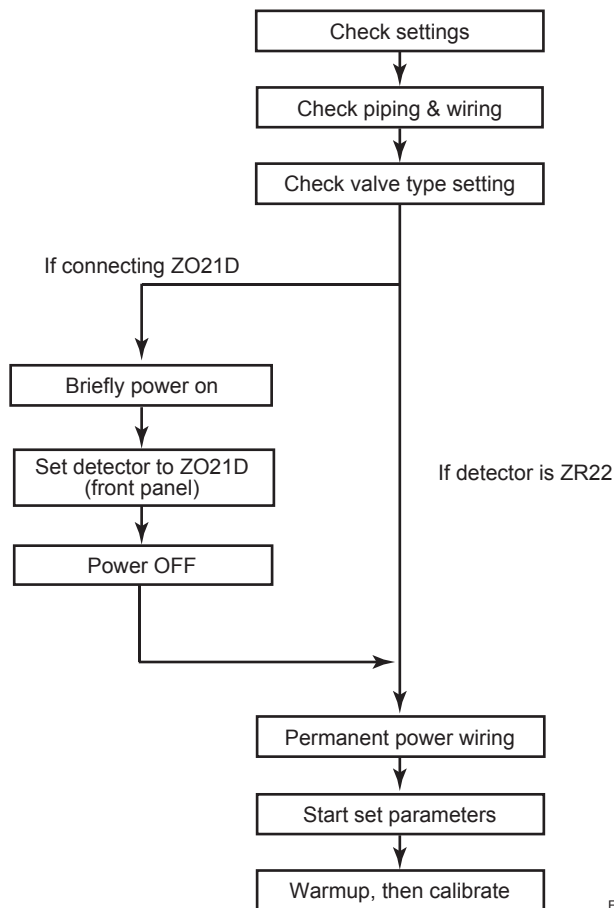

F07-1E.ai

Figure 7.1 Startup Procedure

## 7.2 Checking Piping and Wiring Connections

Check that the piping and wiring connections have been properly completed in accordance with Chapter 4, “Piping,” and Chapter 5, “Wiring.”

### 7.3 Checking Valve Setup

Set up valves and associated components used in the analyzer system as follows:

- (1) If a stop valve is used in the detector's calibration gas inlet, fully close this valve.
- (2) If instrument air is used as the reference gas, adjust the air-set secondary pressure so that an air pressure equals sample gas pressure plus approx. 50 kPa (or sample gas pressure plus approx. 150 kPa when a check valve is used, maximum pressure rating is 300 kPa) is obtained. Turn the reference gas flow setting valve in the flow setting unit to obtain a flow of 800 to 1000 mL/min. (Turning the valve shaft counterclockwise increases the rate of flow. Before turning the valve shaft, if the valve has a lock nut, first loosen the lock nut.) After completing the valve setup, be sure to tighten the lock nut.

#### NOTE

The calibration gas flow setting is described later. Fully close the needle valve in the flow setting unit.

### 7.4 Supplying Power to the Converter

#### CAUTION

To avoid temperature changes around the sensor, it is recommended that (rather than turning it on and off) power be continuously supplied to the Oxygen Analyzer if it is used in an application where it is used periodically.

It is also recommended to flow a span gas (instrument air) beforehand.

Supply power to the converter. A display as in Figure 7.2, which indicates the detector's sensor temperature, then appears. As the heat in the sensor increases, the temperature gradually rises to 750°C. This takes about 20 minutes after the power is turned on, depending somewhat on the ambient temperature and the sample gas temperature.

After the sensor temperature has stabilized at 750°C, the converter is in measurement mode. The display panel then displays the oxygen concentration as in Figure 7.3. This is called the Basic panel display.

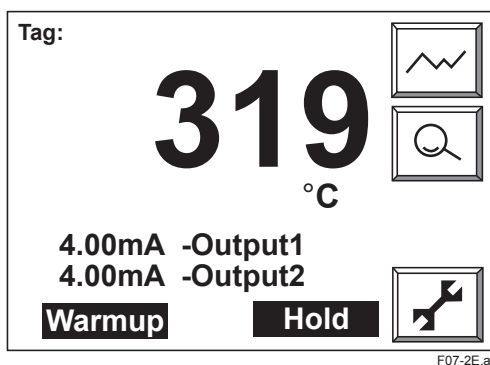

Figure 7.2 Display During Warm-up

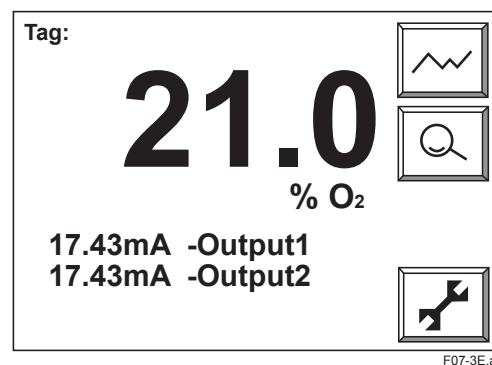

Figure 7.3 Measurement Mode Display

# 7.5 Confirmation of Converter Type Setting

This converter can be used for both the Oxygen Analyzer and the Humidity Analyzer. Before setting the operating data, be sure to check that the desired converter model has been set.

Note that if the converter type setting is changed, the operating data that have been set are then initialized and the default settings remain. To set the desired operating data, follow these steps:

- (1) Press the [Setup] key in the Basic panel display to display the Execution/Setup display (Figure 7.4).
- (2) Use the [▼] key to select “Commissioning” and press the [Enter] key.
- (3) In the Passwords display, enter the [Enter] key. If the password is to be set again, enter the new password (for details, see Subsection 8.6.5, “Setting Passwords” later in this manual).
- (4) The Commissioning display shown in Figure 7.5 appears. Select “Basic setup” and press the [Enter] key.
- (5) The Basic setup display shown in Figure 7.6 then appears. Confirm the currently set converter type. If the Humidity Analyzer option /HS was selected at the time of purchase, the converter was set for high temperature humidity use before shipment.
- (6) If the converter type is to be changed, press the [Enter] key. The display shown in Figure 7.7 then appears.
- (7) Use the [▼] key to select the type of equipment. Then press the [Enter] key to complete the converter selection.
- (8) If the type of converter is changed after setting the operating data, those data are then initialized and the default settings remain. Reset the operating data to meet the new type of equipment.

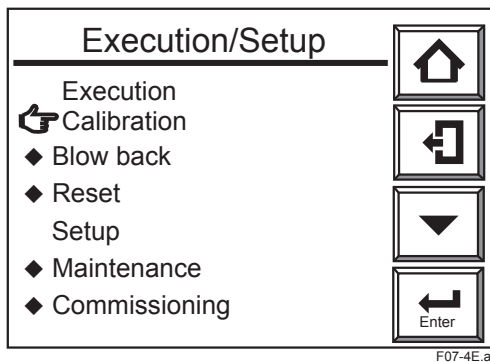

Figure 7.4 “Execution/Setup” Display

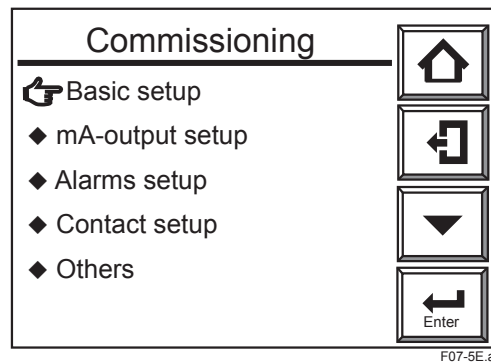

Figure 7.5 “Commissioning” Display

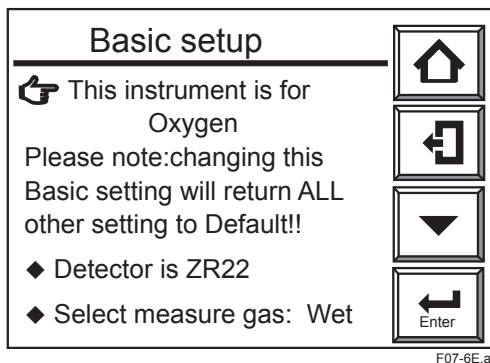

Figure 7.6 “Basic Setup” Display

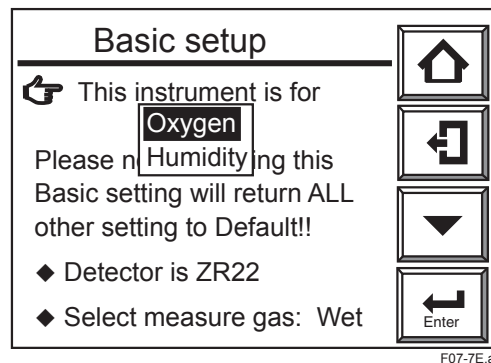

Figure 7.7 Equipment Setup

## 7.6 Confirmation of Detector Type Setting

Check that the detector in Figure 7.6 is the one for this equipment.

### WARNING

- If this converter is to be used in conjunction with the ZO21D\*, the power requirements are limited to 115 V AC or less, 50 or 60 Hz (it cannot be used with a 125 V or greater, or in the EEC).
- If detector settings are to be changed, first disconnect the wiring connections between the detector and the converter. Then change detector settings appropriately.

\* The ZO21D is not a explosion-proof detector.

## 7.7 Selection of Sample Gas

Combustion gases contain moisture created by burning hydrogen in the fuel. If this moisture is removed, the oxygen concentration might be higher than before. You can select whether the oxygen concentration in a wet gas is to be measured directly, or compensated for its dry-gas value before use. Select the “Select measure gas: Wet” in Figure 7.6 to select either wet or dry gas.

## 7.8 Output Range Setting

This section sets forth analog output range settings. For details, consult Section 8.1, “Current Output Setting”, later in this manual.

### ● Minimum Current (4 mA) and Maximum Current (20 mA) Settings

To set the minimum and maximum current settings, follow these steps:

- (1) Select the “Commissioning” in the Execution/Setup display.
- (2) Select the “mA-output setup” in the Commissioning display; the display shown in Figure 7.8 then appears.
- (3) Select the “mA-output 1” in the mA-outputs display. The “mA-output 1 range” display shown in Figure 7.9 then appears.
- (4) In the display shown in Figure 7.9, select “Min. oxygen conc” and press the [Enter] key to display the numeric-data entry display. Enter the oxygen concentration at a 4 mA output; enter [010] for a ten-percent oxygen concentration measurement.
- (5) Also in Figure 7.9, select “Max. oxygen conc” at a 20 mA output. Enter the appropriate maximum oxygen concentration (at the 20 mA output) in the same manner as in step 4 above.
- (6) Set the “mA-output 2” in the same manner as in the appropriate steps above.

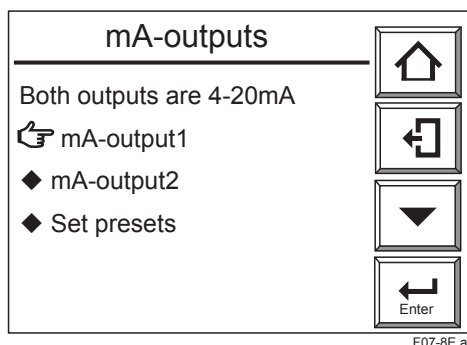

Figure 7.8 Setting “mA-outputs”

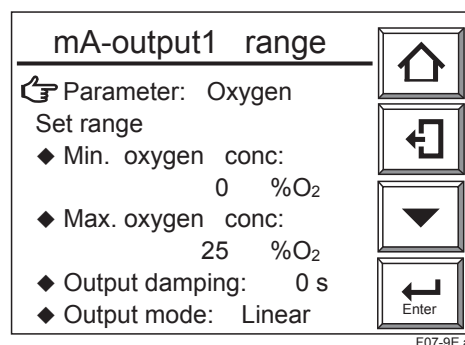

Figure 7.9 Setting “mA-output1 range”

## 7.9 Setting Display Item

This section briefly describes the display item settings shown in Figure 7.9, “Basic Panel Display.”

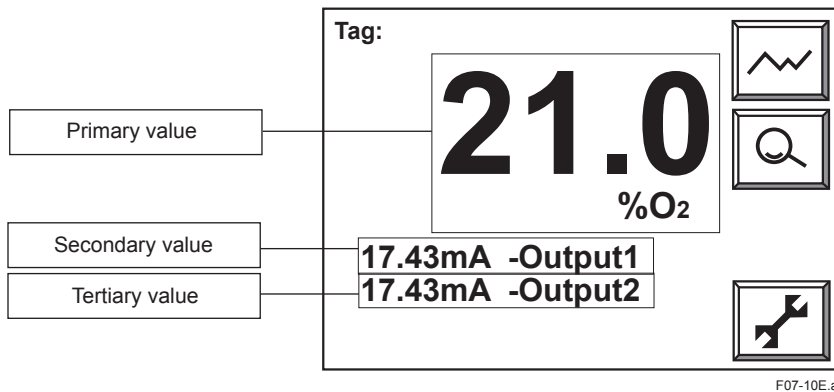

Figure 7.10 Basic Panel Display

- (1) Press the [Setup] key in the Basic panel display to display the Execution/Setup display. Then select the “Maintenance” in the Execution/Setup display.
- (2) Select the “Display setup” in the Maintenance panel display (Figure 7.11). The Display setup display (Figure 7.12) then appears.
- (3) In the above Display setup display, select the “Display item”. The Display item display (Figure 7.13) then appears. From this display, select the “Primary value” and press the [Enter] key to display the “Display item” selection display (Figure 7.14).
- (4) Select the Secondary and Tertiary values in the same manner as in the steps above.
- (5) Consult Table 7.1, Display Items, enabling the selection of display items in individual display areas.

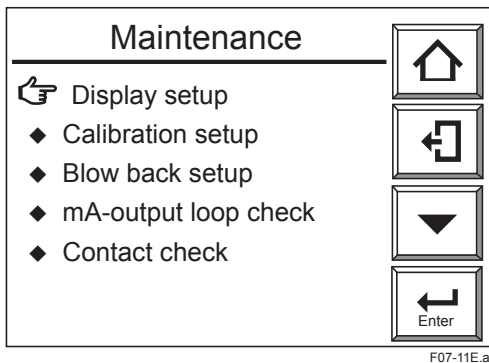

Figure 7.11 “Maintenance” Display

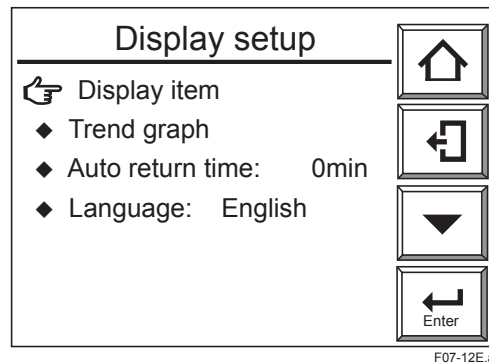

Figure 7.12 Display Setup

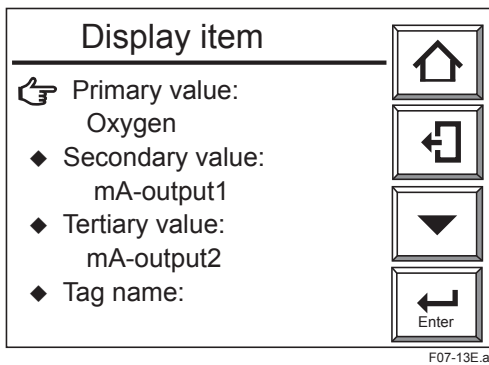

Figure 7.13 “Display Item” Display

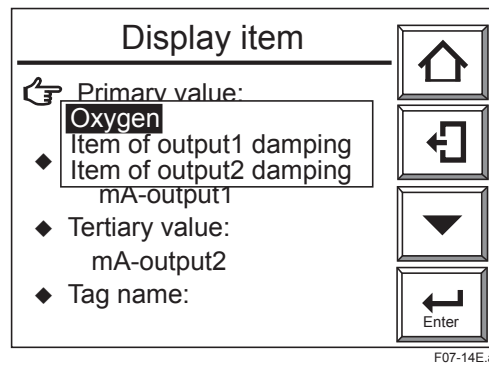

Figure 7.14 Display Item Selection

**Table 7.1 Display Items**

Item	Primary value	Secondary and tertiary values	Display
Oxygen concentration	<input type="radio"/>	<input type="radio"/>	Oxygen concentration during measurement
Air ratio		<input type="radio"/>	Current computed air ratio
Moisture quantity		<input type="radio"/>	Moisture quantity (%H <sub>2</sub> O) in the exhaust gas
Output 1 item	<input type="radio"/>	<input type="radio"/>	Oxygen concentration with the equipment set for oxygen analyzer (See *1 below.)
Output 2 item	<input type="radio"/>	<input type="radio"/>	Oxygen concentration with the equipment set for oxygen analyzer (See *1 below.)
Current output 1		<input type="radio"/>	Output current value from analog output 1
Current output 2		<input type="radio"/>	Output current value from analog output 2

\*1: If an analog output damping constant is set, the oxygen concentration display then includes these settings.

**About the Air ratio:**

“Air ratio” is defined as the ratio of (the amount of air theoretically required to completely burn all the fuel) to (the amount of air actually supplied).

For this equipment, the air ratio will be obtained in a simplified way by measuring the oxygen concentration in the exhaust gas. The air ratio may be expressed mathematically by:

$$m = \{ 1 / ( 21 - \text{Oxygen concentration} ) \} \times 21$$

If you use the air ratio data for estimating the combustion efficiency, etc., check that no air is leaking in beforehand and that the measured value has not been affected by any interference gas (CH<sub>4</sub>, CO, H<sub>2</sub>, etc.).

**About moisture quantity:**

The moisture quantity in the exhaust gas is calculated based on the parameters of the fuel setting (refer to Subsection 8.6.3, “Setting Fuels”, later in this manual). The moisture content may be expressed mathematically by:

Moisture quantity = {(water vapor content per fuel unit quantity) + (water content in air)}/ total amount of exhaust gas

$$= ( Gw + 1.61 \times Z \times Ao \times m ) / ( X + Ao \times m )$$

where,

Gw = Water vapor content in exhaust gas, m<sup>3</sup>/kg (m<sup>3</sup>)

Z = Ambient absolute humidity, kg/kg

Ao = Ideal air amount, m<sup>3</sup>/kg (m<sup>3</sup>)

m = Air ratio

X = Fuel coefficient, Nm<sup>3</sup>/kg or m<sup>3</sup>/m<sup>3</sup>

For details on each parameter, refer to Subsection 8.6.3, “Setting Fuels”.

## 7.10 Checking Current Loop

The set current can be output as an analog output.

- (1) Press the [Setup] key on the Basic panel display to display the Execution/Setup display. Then select the “Maintenance” in the Execution/Setup display.
- (2) Select the “mA-output loop check” in the Maintenance panel display to display the “mA - output loop check” display, enabling you to check the “mA-output 1” and the “mA-output 2”. Select the desired output terminal for current-loop checking (see Figure 7.15).

- (3) At the time of entering the numeric-data entry display, the output current will change to 4 mA (default value). If the desired current is entered, the corresponding output will be provided.

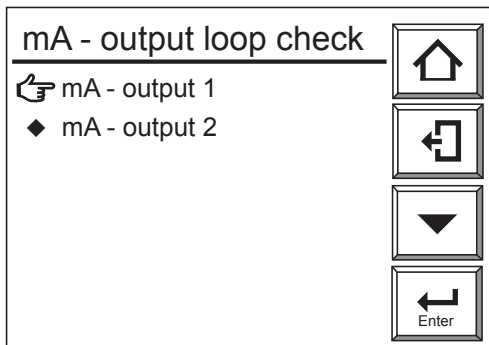

F07-15E.ai

Figure 7.15 "mA - output loop check" Panel Display

## 7.11 Checking Contact I/O

Conduct the contact input and output checking as well as operational checking of the solenoid valves for automatic calibration.

### 7.11.1 Checking Contact Outputs

To check the contact output, follow these steps:

- (1) Press the [Setup] key in the Basic panel display to display the Execution/Setup display. Select "Maintenance" in that display.
- (2) Select "Contact check" then "Output contacts" in the Maintenance panel display to display the Output contacts display (see Figure 7.17).
- (3) In this display, select the desired "output contact" for checking. The display, which enables the closing and opening of contacts, then appears. Use the display to conduct continuity checking.

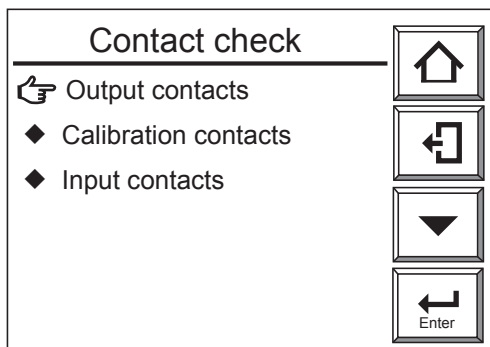

F07-16E.ai

Figure 7.16 "Contact Check" Display

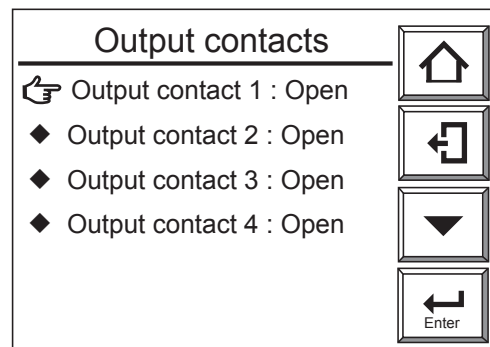

F07-17E.ai

Figure 7.17 "Output contacts" Check Panel Display

### CAUTION

If you conduct an open-close check for "Output contact 4", Error 1 or Error 2 will occur. This is because the built-in heater power of the detector, which is connected to "Output contact 4", is turned off during the above check. So, if the above error occurs, reset the equipment or turn the power off and then back on to restart (refer to Section 10.6, "Reset", later in this manual).



### 7.11.2 Checking Calibration Contact Outputs

The calibration contacts are used for solenoid valve drive signals for the ZR40H Automatic Calibration Unit. When using the ZR40H Automatic Calibration Unit, use the calibration contact output to check that the wiring connections have been properly completed and check equipment operation.

- (1) Referring to Subsection 7.11.1, display the contact check display.
- (2) Select the “Calibration contacts” to display the panel display as Figure 7.18 shows.
- (3) Open the “Zero gas contact” and the “Span gas contact”. This will help check the automatic calibration unit and wiring connections.

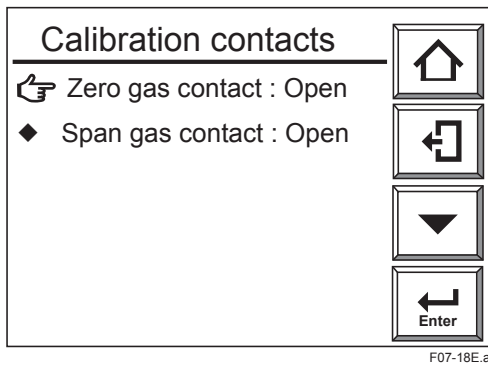

Figure 7.18 “Calibration contacts” Check Panel Display

#### NOTE

“Open” and “Closed” displayed on the Calibration contacts display indicate actions of drive contacts and are opposite to the valve open and close actions. If “Open” is displayed on the Calibration contacts display, no calibration gas flows. If “Closed” is displayed on that display, calibration gas flows.

### 7.11.3 Checking Contact Inputs

- (1) Referring to Subsection 7.11.1, display the contact check display.
- (2) Display the “Input contacts” check display as Figure 7.19 shows. The “Open” or “Closed” Input contact in the display shows the current contact input terminal status and the display changes according to the contact status. Using this enables you to check that the wiring connections have been properly completed.

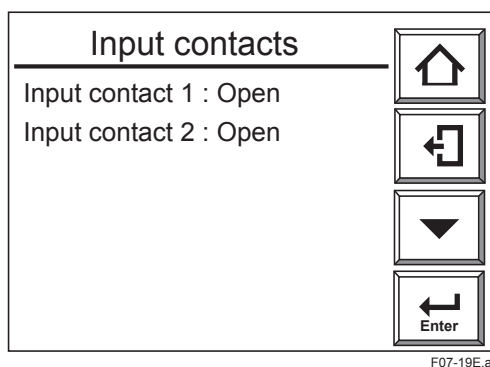

Figure 7.19 “Input contacts” Check Panel Display

## 7.12 Calibration

To calibrate this instrument, the procedure is to measure zero gas and span gas and set the instrument to read the known concentrations. The procedure for both zero and span calibration, or for either zero or span calibration, can be performed manually from the touch display, or can be performed semi-automatically using contact signal inputs to start calibration, (allowing preset calibration and stabilization times), or it can be performed automatically at preset intervals.

There are three types of calibration procedures available:

- (1) Manual calibration conducting zero and span calibrations, or either of these calibrations in turn.
- (2) Semi-automatic calibration which uses the touchpanel or a contact input signal and conducts calibration operations based on a preset calibration and stabilization times.
- (3) Automatic calibration conducted at preset intervals.

Manual calibration needs the ZA8F Flow Setting Unit to allow manual supply of the calibration gases. Semi-automatic and automatic calibrations need the ZR40H Automatic Calibration Unit to allow automatic supply of the calibration gases. The following sections set forth the manual calibration procedures. For details on semi-automatic and automatic calibrations, consult Chapter 9, Calibration, later in this manual.

### 7.12.1 Calibration Setup

#### ■ Mode Setting

For the mode setting, do the following:

Press the [Setup] key in the Basic panel display to display the Execution/Setup display. Select "Maintenance" in the Execution/Setup display to display the Maintenance panel display. Then select "Calibration setup" to display the Calibration setup display as Figure 7.20 shows. Select Mode in this panel, and then select "Manual", "Semi-Auto" or "Auto".

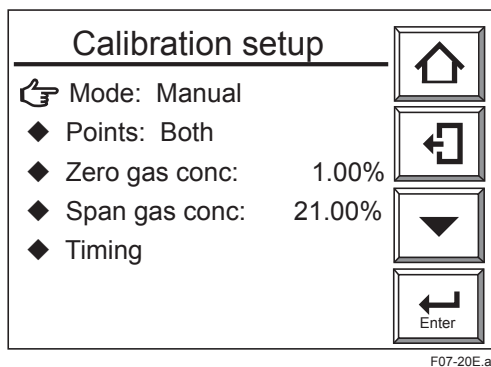

Figure 7.20 "Calibration Setup" Display

#### ■ Calibration Setting Procedures

Select "Points" (calibration procedure) in the Calibration setup display to display the "Both (Span – Zero)", "Span", "Zero" selection display. In this display, select "Both (Span – Zero)".

#### ■ Calibration Gas Concentration Setting

- (1) Zero gas concentration

If zero-gas concentration is selected, the Numeric-data Entry display then appears. Use this display to enter an oxygen concentration value for the zero-gas calibration; if the oxygen concentration is 0.98 vol%O<sub>2</sub>, enter 00098.

(2) Span gas concentration

With "Span gas conc" selected in the Calibration setup display, display the Numeric - data Entry display and enter an oxygen concentration value for the span gas calibration; If instrument air is used, enter 02100 for a 21 vol%O<sub>2</sub> value.

When using the ZO21S Standard Gas Unit (for use of the atmospheric air as a span gas), use a portable oxygen analyzer to measure the actual oxygen concentration, and then enter it.

 **CAUTION**

If instrument air is used for the span gas, dehumidify the air by cooling to a dew point of - 20°C and remove any oil mist or dust.

**7.12.2 Manual Calibration**

■ **Preliminary**

Before performing manual calibration, be sure that the ZA8F Flow Setting Unit zero gas flow setting valve is fully closed. Open the zero gas cylinder pressure reducing valve so that the secondary pressure equals sample gas plus approx. 50 kPa (or sample gas pressure plus approx. 150 kPa when a check valve is used, maximum pressure rating is 300 kPa).

This applies even if you are using the ZR40H Automatic Calibration Unit.

■ **Calibration Procedures**

This manual assumes that the instrument air is the same as the reference gas used for the span gas. Follow the steps below to conduct manual calibration:

- (1) Press the [Setup] key in the Basic panel display to display the Execution/Setup display. Then select "Calibration" in the Execution/Setup display. In doing so, the Calibration display as in Figure 7.21 appears.

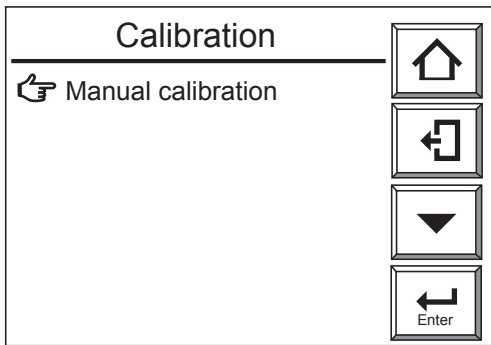

F07-21E.ai

Figure 7.21 "Calibration" Display

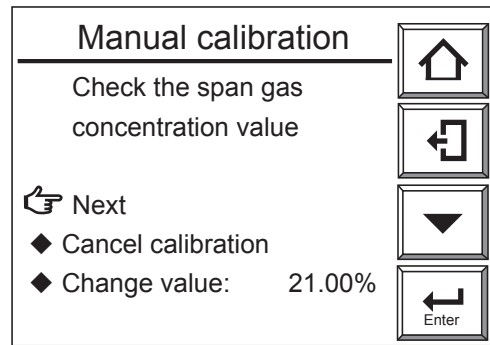

F07-22E.ai

Figure 7.22 "Manual Calibration" Display

- (2) Press the [Enter] key to select "Span calibration". The Manual calibration display shown in Figure 7.22 then appears. Check that the oxygen concentration for the span gas in this display coincides with the oxygen concentration in the calibration gas actually used. If the check results are assumed to be OK, select "Next" in the Manual calibration display.

- (3) Follow the display message in Figure 7.23 to turn on span gas flow. Open the span gas flow valve for the Flow Setting Unit by loosening the valve lock nut and slowly turning the valve shaft counterclockwise to flow the span gas at  $600 \pm 60$  ml/min. Use the calibration gas flowmeter to check the flow.

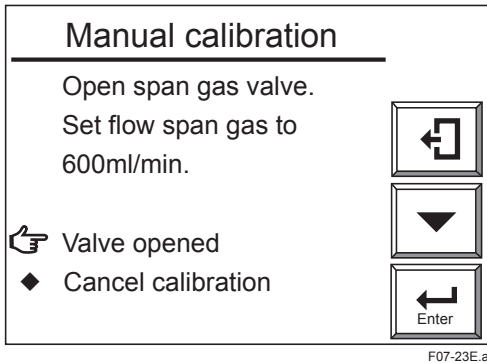

Figure 7.23 Span Gas Flow Display

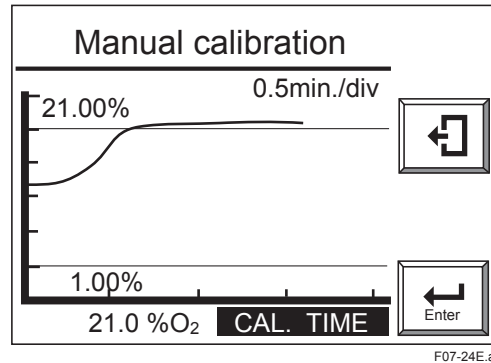

Figure 7.24 Span Gas Trend Graph (for Manual Calibration)

- (4) If “Valve opened” is selected as in Figure 7.23, an oxygen concentration trend graph (with the oxygen concentration being measured) appears (see Figure 7.24). The CAL.TIME in the bottom area of the panel flashes. Observe the trend graph and wait until the measured value stabilizes in the vicinity of 21% on the graph. At this point, calibration has not yet been executed yet, so even if the measured value is above or below 21%, no problem occurs.
- (5) After the measured value has stabilized, press the [Enter] key to display the “Span calibration complete” display shown in Figure 7.25. At this point, the measured value is corrected to equal the span gas concentration setting. Close the span gas flow valve. The valve lock nut should be tightened completely so that the span gas does not leak.

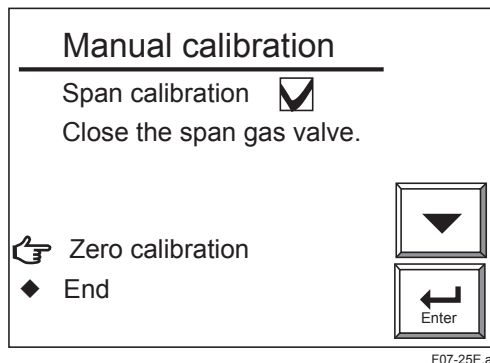

Figure 7.25 Span Calibration Complete Zero Calibration Start Display (in Manual Calibration)

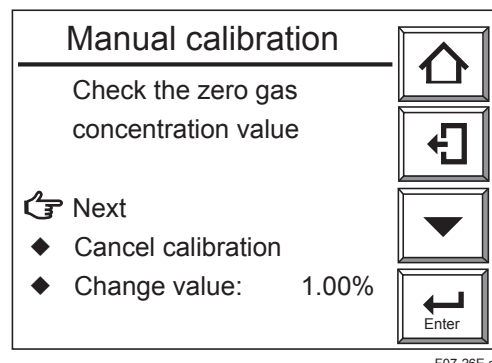

Figure 7.26 Zero Gas Concentration Check Display

- (6) Select “Zero calibration” as in Figure 7.25 to display the zero gas concentration check display (Manual calibration) . Check that the zero gas oxygen concentration value and the calibration gas oxygen concentration value agree. Then select “Next” as in Figure 7.26.

- (7) Follow the instructions in the display as in Figure 7.27 to turn on the zero gas flow. To do this, open the zero gas flow valve for the Flow Setting Unit and adjust that valve to obtain a flow of  $600 \pm 60$  ml/min.  
(The valve should be adjusted by loosening its lock nut and slowly turning the valve shaft counterclockwise. Use the calibration gas flowmeter to check the flow.)

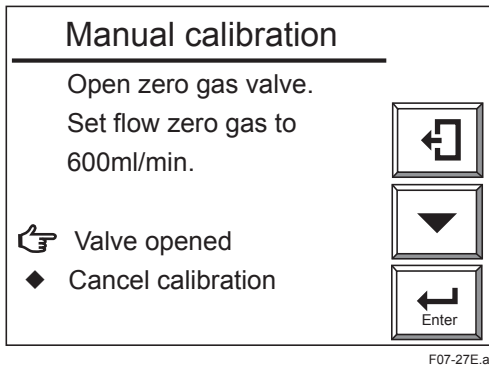

Figure 7.27 Zero Gas Flow Display (for Manual calibration)

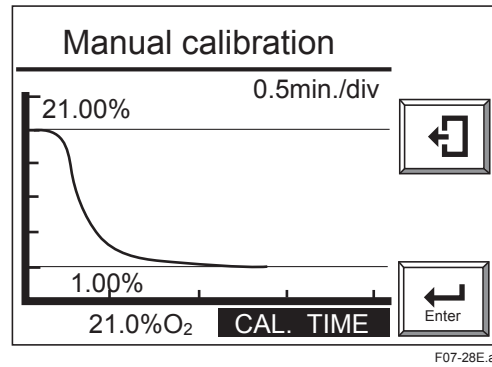

Figure 7.28 Manual Calibration, Trend Graph

- (8) If "Valve opened" is selected as in Figure 7.27, an oxygen concentration trend graph (with the oxygen concentration being measured) appears (see Figure 7.28). The CAL.TIME in the bottom area of the panel flashes. Observe the trend graph and wait until the measured value stabilizes in the vicinity of the zero gas concentration on the graph. At this point, no calibration has been executed yet, so even if the measured value is above or below the zero gas concentration value, no problem occurs.
- (9) After the measured value has stabilized, press the [Enter] key to display the "Zero calibration complete" display shown in Figure 7.29. At this point, the measured value is corrected to equal the zero gas concentration setting. Close the zero gas flow valve. The valve lock nut should be tightened completely so that the zero gas does not leak.

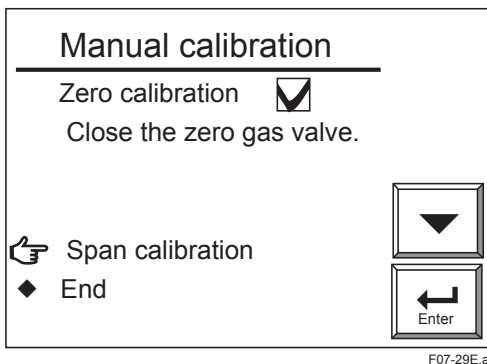

Figure 7.29 Zero Calibration Complete Display

- (10) Select "End" in the display as shown in Figure 7.29. An oxygen concentration trend graph (with the oxygen concentration being measured) appears and HOLD TIME then flashes. This time is referred to as the output-stabilization time. If the HOLD TIME has been set with the output hold setting, the analog output remains held (refer to Section 8.2, Output Hold Setting, later in this manual). Manual calibration is completed when the preset hold (output stabilization) time elapses. This hold (output stabilization) time is set to 10 minutes at the factory before shipment. If you press the [Enter] or [Reject] key within the hold (output stabilization) time, manual calibration is then completed.

---

## 8. Detailed Data Setting

### 8.1 Current Output Setting

This section describes setting of the analog output range.

#### 8.1.1 Setting Minimum Current (4 mA) and Maximum Current (20 mA)

To set the minimum and maximum currents, proceed as follows:

- (1) Select the "Commissioning" in the Execution/Setup display.
- (2) Select the "mA-output setup" in the Commissioning display.
- (3) Select the "mA-output1" in the mA-outputs display.
- (4) Select the "Min. oxygen conc" in the mA-output1 range display and press the [Enter] key. The numeric-data entry display then appears. Enter the oxygen concentration for the minimum current (4 mA); for example, enter "010" for 10 vol%O<sub>2</sub>.
- (5) Select the "Max. oxygen conc" in the mA-output1 range display and enter the oxygen concentration for the maximum current (20 mA) in the same manner as in step 4 above.
- (6) Set the "mA-output2" in the same way as the setting procedure for mA-output1 given above.

#### 8.1.2 Input Ranges

The range low and high values are restricted as follows:

The range min. O<sub>2</sub> concentration value (corresponding to 4 mA output) can be set to either 0 vol%O<sub>2</sub> or in the range of 6 to 76 vol%O<sub>2</sub>.

The range max. O<sub>2</sub> concentration value (corresponding to 20 mA output) can be set to any value in the range of 5 to 100 vol%O<sub>2</sub>, however the range max. setting must be at least 1.3 times the range min. setting.

If you do not observe this restriction, the measurement will be invalid, and any previous valid value will be used. The gray area in figure represents the valid setting range.

##### Setting example 1

If the range minimum (corresponding to 4 mA output) is set to 10 vol%O<sub>2</sub> then range maximum (corresponding to 20 mA output) must be at least 13 vol%O<sub>2</sub>.

**Setting example 2**

If the range minimum (corresponding to 4 mA output) is set to 75 vol%O<sub>2</sub> then range maximum (corresponding to 20 mA output) must be at least 75x1.3=98 vol%O<sub>2</sub> (rounding decimal part up).

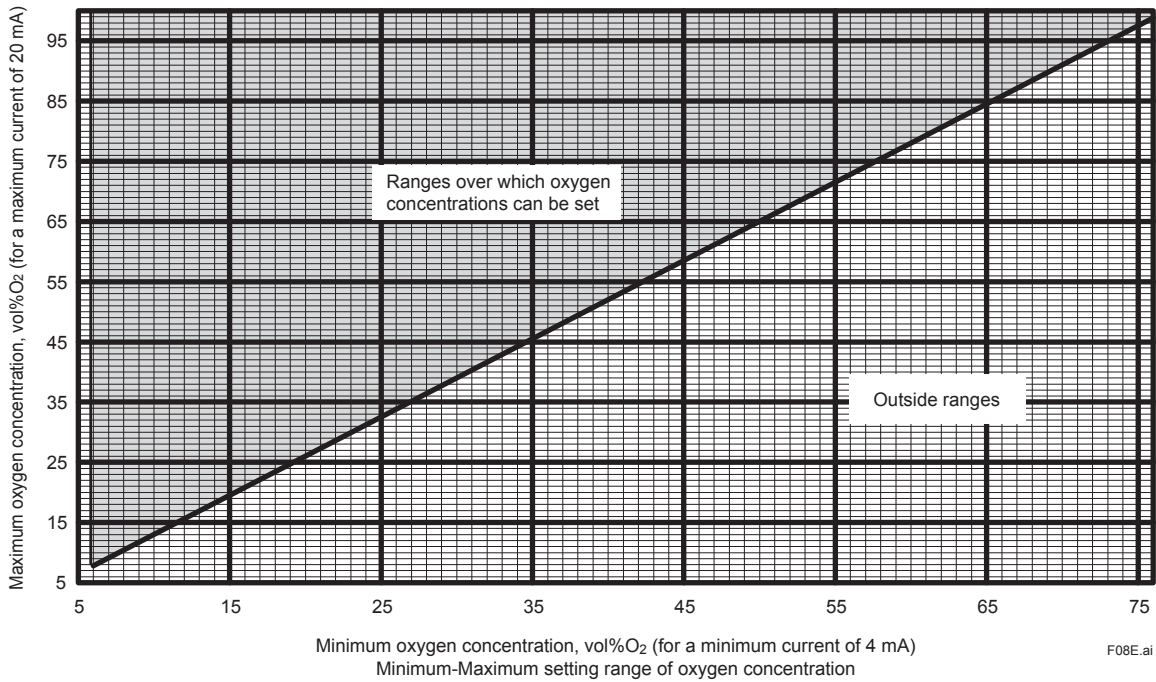

**8.1.3 Setting Output Smoothing Coefficient**

When the oxygen concentration in the sample gas fluctuates rapidly, if the measured value is used for control this can lead to problems with undesirable frequent ON/OFF switching. You can set a smoothing time constant of between 0 and 255 seconds to reduce the effect. Select the appropriate output damping constant from the numeric-data entry display. To set 30 seconds, enter 030.

**8.1.4 Selection of Output Mode**

You can select whether the relationship between the sample oxygen concentration and the analog output signal be linear or logarithmic. Press the [Enter] key in the output mode display. A linear/ logarithmic selection display then appears. Select the desired mode.

**NOTE**

If you select an output mode of "logarithmic" then regardless of range setting the minimum output value becomes 0.1 vol%O<sub>2</sub> fixed.

**8.1.5 Default Values**

When the analyzer is delivered or reset to defaults, the output current default settings by as shown in Table 8.1.

**Table 8.1 Output Current Default Values**

Item	Default setting
Min. oxygen concentration	0 vol%O <sub>2</sub>
Max. oxygen concentration	25 vol%O <sub>2</sub>
Output damping constant	0 (seconds)
Output mode	Linear

## 8.2 Output Hold Setting

The “output hold” functions hold an analog output signal at a preset value during the equipment’s warm-up time or calibration or if an error arises. Outputs 1 and 2 can not be set individually. Table 8.2 shows the analog outputs that can be retained and the individual states.

Table 8.2

Equipment status Output hold values available	During warm-up	Under maintenance	Under calibration During blow back	On Error occurrence(*1)
4 mA	○			
20 mA	○			
Without hold feature		○	○	○
Retains output from just before occurrence		○	○	○
Set value (2.4 to 21.6 mA)	○	○	○	○

○: The output hold functions are available.

\*1: The output hold functions on error occurrence are unavailable when option code “/C2” or “/C3”(NAMER NE 43 compliant) is specified.

### 8.2.1 Definition of Equipment Status

#### (1) During warm-up

“During warm-up” is the time required after applying power until sensor temperature stabilizes at 750 °C and the instrument is in the measurement mode.

#### (2) Under Maintenance

“Under maintenance” is the time that starts when you move to the Execution/Setup display by touching the [Setup] key on the Basic panel display and ends when you return to the Basic panel display. It includes when you operates keys on lower level menu displays of the Execution/Setup display.

#### (3) Under Calibration (see Chapter 9, Calibration, later in this manual)

For manual Calibration, “Under calibration” is the time that starts when you move to the Manual calibration display (Figure 7.22) from the Calibration display, lasts while you are operating keys for performing calibration manually, and ends when you press the End key and after a preset hold time has elapsed.

For semi-automatic calibration, “Under calibration” is the time required from entering calibration instructions to perform a, either by using the touchpanel or by a contact input, calibration until the hold (output stabilization) time elapses.

For automatic calibration, “Under calibration” is the time required, after performing an appropriate calibration until the hold (output stabilization) time elapses.

#### (4) During Blow back (see Section 10.4, Blow Back, later in this manual)

##### During semi-automatic blow back:

“During semi-automatic blow back” is the time required after pressing the [Blow back start] key, by using the touchpanel or entering a blow back start instruction by using a contact input, until the blow back time and hold (output stabilization) time elapse.

##### During automatic blow back:

“During automatic blow back” is the time required after reaching the blow back start time until the blow back time and hold (output stabilization) time elapse.

#### (5) On Error occurrence

This is the time at which any of Errors 1 to 4 occurs.



### 8.2.2 Preference Order of Output Hold Value

The output hold value takes the following preference order:

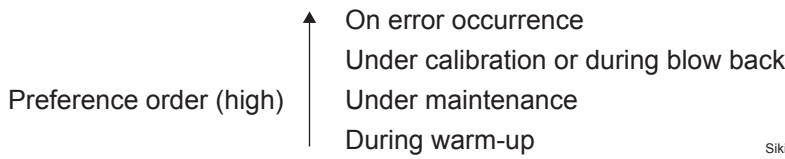

Siki08-1E.ai

For example, if the output current is set to 4 mA during maintenance, and no output-hold output for during calibration is preset, the output is held at 4 mA during the maintenance display. However, the output hold is released at the time of starting the calibration, and the output will be again held at 4 mA after completing the calibration and when the hold (output stabilization) time elapses.

### 8.2.3 Output Hold Procedure

To set the output hold, follow these steps:

- (1) Press the [Setup] key in the Basic panel display to display the Execution/Setup display. Then select "Commissioning" in the Execution/Setup display. Next, select the "mA-output setup" and "Set presets", then the "mA-outputs presets" display as shown in Figure 8.1.

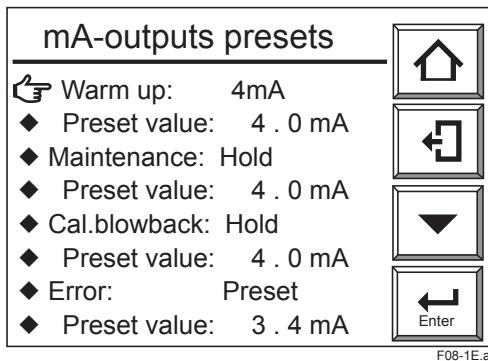

Figure 8.1 "mA-outputs presets" Display

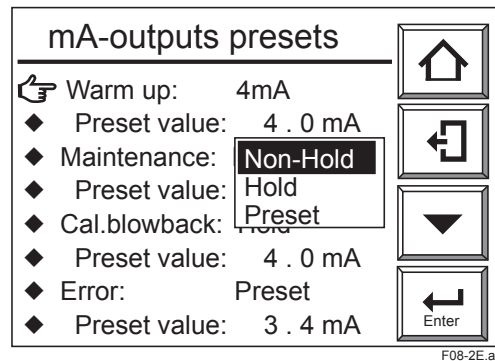

Figure 8.2 Selecting Maintenance

- (2) From this display (Figure 8.1), select the desired display. Figure 8.2 shows an example of selecting "Maintenance". Select the desired output status.
- (3) If a preset value is selected, set the corresponding output current. If you select a preset value just below Maintenance on the screen, the numeric-data entry display will appear. Enter the current value you want. To set 10 mA, type in 010 and press the [Enter] key to complete the setting. The setting range is from 2.4 to 21.6 mA.

### NOTE

"Error" of mA-outputs presets is not displayed when option code "/C2" or "/C3" (NAMUR NE 43 compliant) is specified.

### 8.2.4 Default Values

When the analyzer is delivered, or if data are initialized, output hold is the default as shown in Table 8.3.

**Table 8.3 Output Hold Default Values**

Status	Output hold setting	Preset value
During warm-up	4 mA	4 mA
Under maintenance	Holds output at value just before maintenance started	4 mA
Under calibration or blow back	Holds output at value just before starting calibration or blow back	4 mA
On Error occurrence	Holds output at a preset value	3.4 mA

## 8.3 Oxygen Concentration Alarms Setting

The analyzer enables the setting of four alarms — high-high, high, low, and low-low alarms — depending upon the oxygen concentration. The following section sets out the alarm operations and setting procedures.

### 8.3.1 Setting the Alarm Values

#### (1) High-high and high alarm values

If high-high and high alarm values are set to ON, then alarms occur if measured values exceed the alarm set values. The oxygen alarm set values can be set in the range of 0 to 100 vol%O<sub>2</sub>.

#### (2) Low and low-low alarm values

If low-low and low alarm values are set, then alarms occur if measured values fall below the alarm set values. The oxygen alarm set values can be set in the range of 0 to 100 vol%O<sub>2</sub>.

### 8.3.2 Alarm Output Actions

If the measured values of the oxygen concentration fluctuate between normal (steady-state) values and the alarm setting, alarm outputs may be frequently issued and canceled.

To avoid this, set the alarm delay and hysteresis for alarm canceling under the alarm output conditions, as Figure 8.3 shows.

When a delay time is set, an alarm will not be issued so quickly even if the measured value differs from the steady-state and enters the alarm setpoint range.

If the measured value remains within the alarm setpoint range for a certain period of time (for the preset delay time), an alarm will be issued. On the other hand, there will be a similar delay each time the measured value returns to the steady-state from the alarm setpoint range (canceling the alarm status).

If hysteresis is set, alarms will be canceled when the measured value is less than or greater than the preset hysteresis values.

If both the delay time and hysteresis are set, an alarm will be issued if the measured value is in the alarm setpoint range and the delay time has elapsed.

For the alarm to be reset (canceled), the measured value must be beyond the preset hysteresis value and the preset delay time must have elapsed.

Refer to Figure 8.3 for any further alarm output actions. The delayed time and hysteresis settings are common to all alarm points.

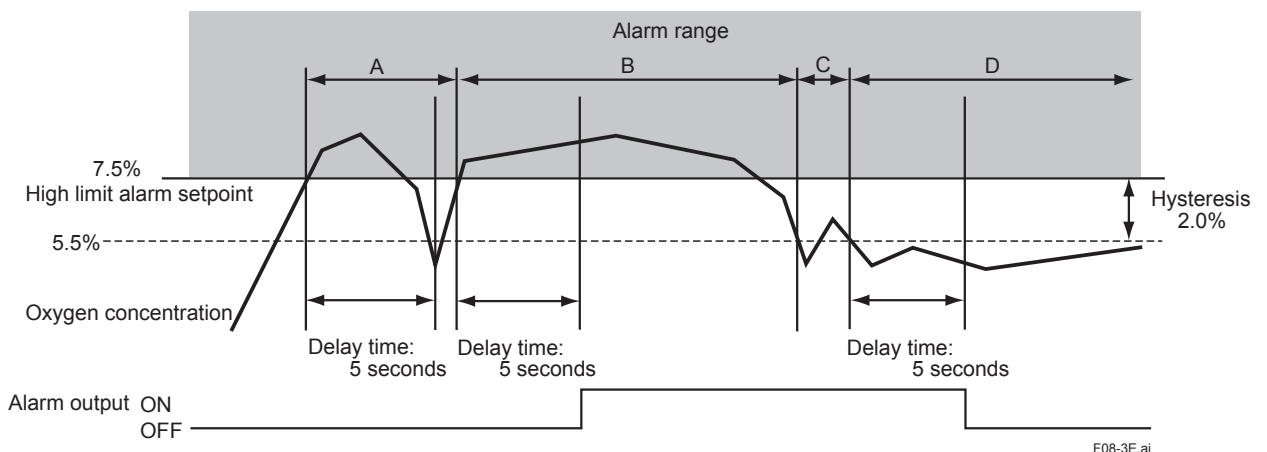

Figure 8.3 Alarm Output Action

F08-3E.ai

In the example in Figure 8.3, the high limit alarm point is set to 7.5 vol%O<sub>2</sub>, the delay time is set to five seconds, and hysteresis is set to 2 vol%O<sub>2</sub>.

Alarm output actions in each section in this figure are as follows:

- A. Although the oxygen concentration value exceeds the high limit alarm setpoint, it falls below the high limit alarm setpoint before the preset delay time of five seconds elapses. So, no alarm is issued.
- B. The oxygen concentration value exceeds the high limit alarm setpoint and the delay time elapses during that measurement. So, an alarm is issued.
- C. Although the oxygen concentration value falls below the hysteresis set value, the value rises again and exceeds the hysteresis set value before the preset delay time elapses. So, the alarm is not canceled.
- D. The oxygen concentration value falls below the hysteresis set value and the preset delay time elapses, so the alarm is canceled.

### 8.3.3 Alarm Setting Procedure

**To set the alarm setpoints, follow these steps:**

- (1) Press the [Setup] key in the Basic panel display to display the Execution/Setup display.
- (2) Select "Commissioning" in the Execution/Setup display. The Commissioning display then appears.
- (3) Select the "Alarms setup" in the Commissioning display. The Alarms setup display shown in Figure 8.4 then appears.
  - **To set the hysteresis, proceed to the following steps.**
- (4) Select "Hysteresis" in the Alarms setup display. The numeric-data entry display then appears. Enter the desired hysteresis value as a percent of oxygen concentration. To set 2.5 vol%O<sub>2</sub>, enter "0025." The hysteresis setting can be in the range of 0 to 9.9 vol%O<sub>2</sub>.
  - **To set the delay time, proceed as per the following steps.**
- (5) Select the "Contact delay" in the Alarms setup display. The numeric-data entry display then appears. Enter the desired delay time, in seconds. To set three seconds, enter "003." The delay time setting can be in the range of 0 to 255 seconds.
  - **To set the alarm point, proceed to the following steps.**
- (6) Select the "Setpoints" in the Alarms setup display. The Oxygen alarms display then appears, as shown in Figure 8.5.
- (7) When you select "High alarm" in the Oxygen alarms display, the "OFF" or "ON" selection display then appears. If you select "ON," the High alarm will then be enabled (enable/disable).
- (8) To set the High alarm values select "Set value" just below the High alarm. The numeric-data entry display then appears. Enter the alarm set value (percent of oxygen concentration). If you want to set the alarm value to 10 vol%O<sub>2</sub>, enter "010."
- (9) Set the other alarm settings in the same manner as in the steps above.

### NOTE

No alarm is issued when alarm is set to "OFF" (disabled). To use the alarm functions, be sure to set the alarms "ON".

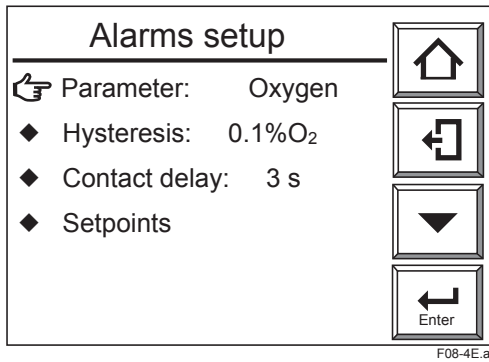

Figure 8.4 "Alarms Setup" Display

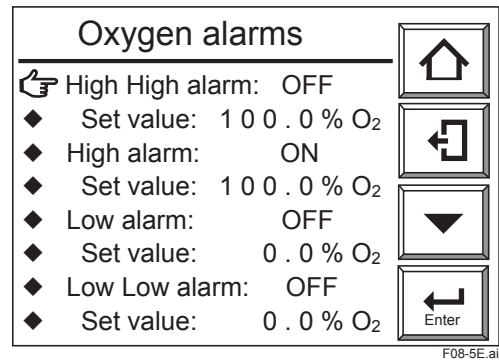

Figure 8.5 "Oxygen Alarms" Display

### 8.3.4 Default Values

When the analyzer is delivered, or if data are initialized, the default alarm set values are as shown in Table 8.4.

Table 8.4 Alarm Setting Default Values

Item	Setting range	Default setting
Hysteresis	0 to 9.9 vol%O <sub>2</sub>	0.1 vol%O <sub>2</sub>
Delay time	0 to 255 seconds	3 seconds
High-high limit alarm		OFF
High-high limit alarm setpoint	0 to 100 vol%O <sub>2</sub>	100 vol%O <sub>2</sub>
High limit alarm		OFF
High limit alarm setpoints	0 to 100 vol%O <sub>2</sub>	100 vol%O <sub>2</sub>
Low limit alarm		OFF
Low limit alarm setpoint	0 to 100 vol%O <sub>2</sub>	0 vol%O <sub>2</sub>
Low-low limit alarm		OFF
Low-low limit alarm setpoint	0 to 100 vol%O <sub>2</sub>	0 vol%O <sub>2</sub>

## 8.4 Contact Output Setting

### 8.4.1 Contact Output

Mechanical relays provide contact outputs. Be sure to observe relay contact ratings. (For details, see Section 2.1, General Specifications) The operation modes of each contact output are as follows. For Output contacts 1 to 3 you can select open or closed contact when the contact is "operated". Default is closed. For Output contact 4, contact is closed. When power fails, Output contacts 1 to 3 are open, and 4 is closed.

Table 8.5

Display	State when contact "operated"	When no power is applied to this equipment
Output contact 1	Open (deenergized) or closed (energized) selectable.	Open
Output contact 2	Open (deenergized) or closed (energized) selectable.	Open
Output contact 3	Open (deenergized) or closed (energized) selectable.	Open
Output contact 4	Closed (deenergized) only	Closed

### 8.4.2 Setting Procedure

To set the contact output, follow these steps.

- (1) Press the [Setup] key in the Basic panel display to display the Execution/Setup display.
- (2) Select the "Commissioning" in the Execution/Setup display. The Commissioning display then appears.
- (3) Select the "Contact setup" in the Commissioning display. The Contact setup display shown in Figure 8.6 then appears.
- (4) Select the desired Output contact. This section shows an example where "Output contact 1" is selected (see Figure 8.7).
- (5) Each set item and the selected items are briefly described in Table 8.6. The following describes an example of setting where Output contact 1 is closed during calibration.
- (6) Select "Others" in the Output contact 1 display. The "Contact1 Others" display shown in Figure 8.8 then appears. Select "Calibration" in the Contact1 Others display.
- (7) The ON or OFF selection display then appears. Select "ON" herein.
- (8) Press the [Reject] key to go back to the previous display.
- (9) Move the pointer to "During power-off the contact is open and in condition it is Open" and press the [Enter] key. The "OFF" or "ON" selection display then appears. If you select "OFF," this means "Open" in normal conditions and "Closed" when the contact output is on.

### CAUTION

- The Output contact 4 is fixed as "close in power ON", which cannot be changed by setting.

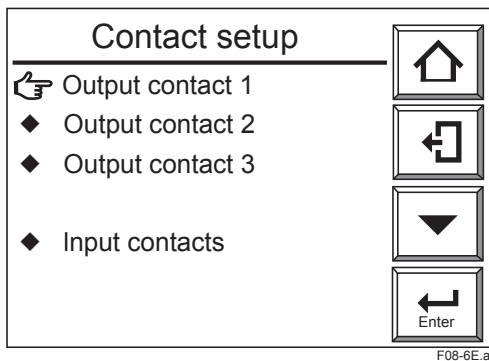

Figure 8.6 "Contact Setup" Display

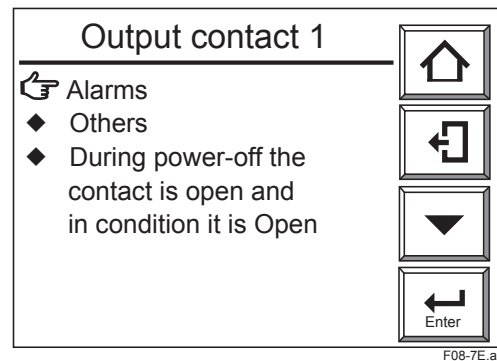

Figure 8.7 "Output Contact 1" Display

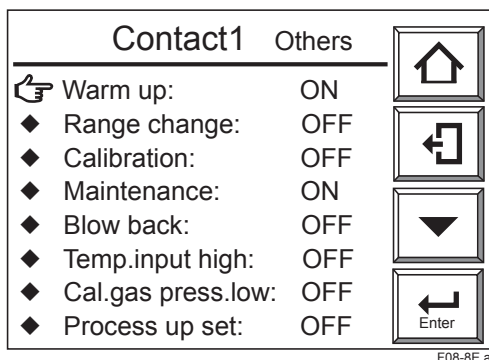

Figure 8.8 "Contact1 Others" Display

**Table 8.6 Contact Output Settings**

	Item to be selected	Brief description
Alarm and Error settings	High-high limit alarm	If “High-High alarm ON” is selected, contact output occurs when the high-high limit is issued. To do this, it is required, in Alarms setup, that the high-high alarm be set on beforehand (see Section 8.3).
	High limit alarm	If “High alarm ON” is selected, contact output occurs when the high limit alarm is provided. To do this, it is required, in Alarms setup, that the high limit alarm be set on beforehand (see Section 8.3).
	Low limit alarm	If “Low alarm ON” is selected, contact output occurs when the low limit alarm is provided. To do this, it is required, in Alarms setup, that the low limit alarm be set on beforehand (see Section 8.3).
	Low-low limit alarm	If “Low-Low alarm ON” is selected, contact output occurs when the low-low limit alarm is issued. To do this, it is required, in Alarms setup, that the low-low alarm be set on beforehand (see Section 8.3).
	Calibration coefficient (correction ratio) alarm	If Calibration correction ratio alarm is ON (enabled), then when a zero calibration correction ratio alarm (Alarm 6) or span calibration correction ratio alarm (Alarm 7) occurs then calibration correction ratio alarm contact output occurs (see Subsection 12.2.1)
	Startup power stabilization timeout alarm	If set ON then contact output occurs when startup power stabilization timeout alarm (Alarm 8) occurs (see Subsection 12.2.1)
	Error	If “Error ON” is selected, contact output occurs when an error is issued. (See Subsection 12.1.1).
Other settings	Warm-up	If “Warm-up ON” is selected, contact output occurs during warm-up. For the definition of Warm-up (see Subsection 8.2.1).
	Output range change	If “Range change ON” is selected, contact output occurs (“answer-back signal to a range change signal”) while a range change signal is applied to a contact input. To do this, it is required, in “Input contacts” setup, that the range change be selected beforehand. For more on this (see Subsection 8.5.2).
	Calibration	If “Calibration ON” is selected, contact output occurs during calibration. For the definition of Under calibration (see Subsection 8.2.1).
	Maintenance	If “Maintenance ON” is selected, contact output occurs during maintenance. For the definition of Under maintenance (see Subsection 8.2.1).
	Blow back	If “Blow back ON” is selected, contact output occurs during blow back. For the definition of During blow back (see Subsection 8.2.1).
	High limit temperature alarm	Not supported by the oxygen analyzer.
	Calibration gas press. low	If “Cal. gas press. low ON” is selected, contact output occurs (“answer-back signal to a calibration gas low pressure signal”) when a calibration gas low pressure signal is applied to the contact input. To do this, it is required, in “Input contacts” setup, that “Cal. gas press. low” be selected beforehand. For more on this (see Subsection 8.5.2).
Process upset	If “Process upset” is selected, contact output occurs (“answer-back signal to a process upset signal) when the process upset signal is applied to the contact input. To do this, it is required, in “Input contacts” setup, that “Process up set” be selected beforehand (see Subsection 8.5.2).	

Note: To provide an alarm with a contact output, be sure to make an alarm setting.  
 When using contact output as an answer-back signal for an input contact, be sure to make a contact input settings.

### 8.4.3 Default Values

When the analyzer is delivered, or if data are initialized, alarm and other setting defaults are as shown in Table 8.7.

**Table 8.7 Contact Output Default Settings**

	Item to be selected	Output contact 1	Output contact 2	Output contact 3	Output contact 4
Alarm settings	High-high limit alarm				—
	High limit alarm			ON	—
	Low limit alarm			ON	—
	Low-low limit alarm				—
	Calibration coefficient (correction ratio) alarm				—
	Startup power stabilization timeout alarm				—
	Error				ON
Other settings	Warm-up	ON			—
	Output range change				—
	Calibration		ON		—
	Maintenance	ON			—
	Blow back				—
	High limit temperature alarm				—
	Calibration gas press. low	(default)	(default)	(default)	—
	Process upset				—
	Operating contact status	Open	Closed	Closed	Closed (fixed)

Note: Blank boxes in the above table indicate that the default is "disabled".



## 8.5 Contact Input Setting

### 8.5.1 Contact Input Functions

The converter “Input contacts” execute set functions by accepting a remote dry-contact (“voltage-free contact”) signal. Table 8.8 shows the functions executed by a remote contact signal.

**Table 8.8 Contact Input Functions**

Item	Function
Calibration gas pressure low	Contact input disables Semi-automatic or Automatic Calibration.
Measuring range change	While Contact signal is ON, range of mA-Output 1 is switched to 0-25 vol%O <sub>2</sub> and “Range” is displayed on the screen. See Figure 8.9.
Calibration start	Contact input starts Semi-Automatic Calibration. Calibration Mode setting must be [Semi_Auto] or [Auto]. Contact signal must be applied for at least 1 sec. Even if input signal continues to be applied, calibration is not repeated unless contact input is released then reapplied.
Process upset (Combustible gas detection)	If the Contact signal is ON, heater power will be switched off. (A one- to 11-second time interval single-output signal is available as a contact signal.) If this operation starts, the sensor temperature decreases and an error occurs. To restore it to normal, turn the power off and then back on, or reset the analyzer.
Blow back start	Contact input starts Blow back. Contact signal must be applied for at least 1 sec. Even if input signal continues to be applied, Blow back is not repeated unless contact input is released then reapplied. (Refer to Section 10.4, Blow Back.)

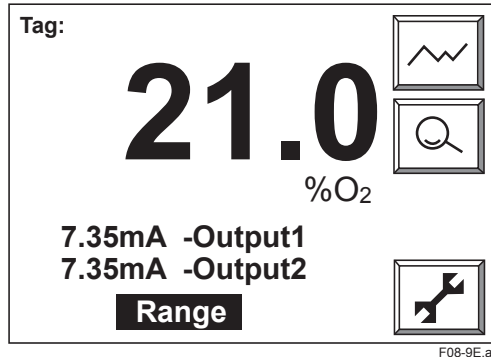

**Figure 8.9 Changing Measuring Range with Contact Input**

### CAUTION

1. Measurement range switching function by an external contact input is available for analog output1 only.
2. When making a semi-automatic calibration, be sure to set the semi-automatic or automatic mode using the Calibration setup display.
3. When carrying out blow back, be sure to set “Blow back” in the “Contact setup”.
4. When the combustible gas detection signal is sent to the contact input, the converter will cut the power supply to the heater of the detector. As a result, the heater temperature becomes low and Error 1 or Error 2 happens.

### 8.5.2 Setting Procedure

This setting example shows how to set “When Input contact 1 Open, Start Semi\_Auto Calibration”. Refer to Section 7.11.3.

- 1) From the Basic panel display touch [Setup] key, and the Execution/Setup display appears.
- 2) Select “Commissioning” and the Commissioning display appears.
- 3) Select “Contact setup” then “Input contacts”.
- 4) Select “Input 1” . Function Selection window (Fig 8.11) appears.
- 5) Select “Calibration start”.
- 6) For Input contact 1 select (operate if) “Closed”. (You can select “Open” or “Closed”).
- 7) Change Closed to Open.

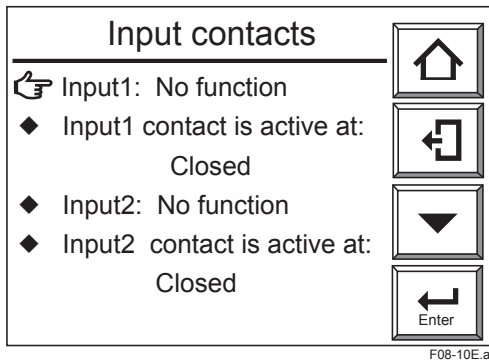

Figure 8.10 “Input Contacts” Display

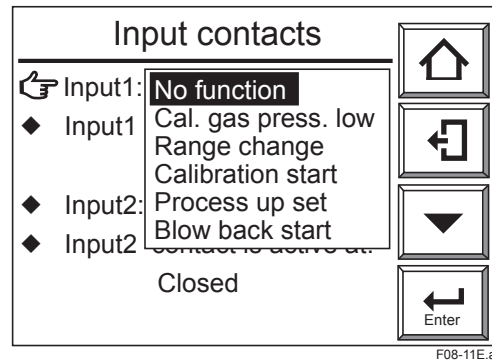

Figure 8.11 “Input Contacts” Display

### 8.5.3 Default Values

All contact inputs are set to “No function”(disabled) prior factory shipment or after data initialization.

## 8.6 Other Settings

### 8.6.1 Setting the Date-and-Time

The following describes how to set the date-and-time. Automatic calibration or blow back works following this setting.

**Proceed as follows:**

- 1) If you touch the [Setup] key in the Basic panel display, the Execution/Setup display appears.
- 2) Select the "Commissioning" and the Commissioning display appears.
- 3) Select the "Others" and the display of Fig 8.12 appears.
- 4) Select the "Clock" and the display of Fig 8.13 appears.
- 5) Select the "Set date" and the numerical entry display appears. To enter June 21, 2004 , enter 210604. Touch the [Enter] key and you revert to the display of Fig 8.13.
- 6) Select the "Set time". Enter the time in 24-hour format. To set 2:30 pm, enter 1430 on the numerical display and touch enter. Touch the [Enter] key, the clock starts from 00 seconds..

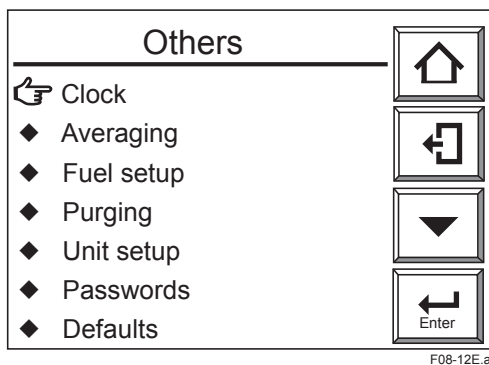

Figure 8.12 Other Settings

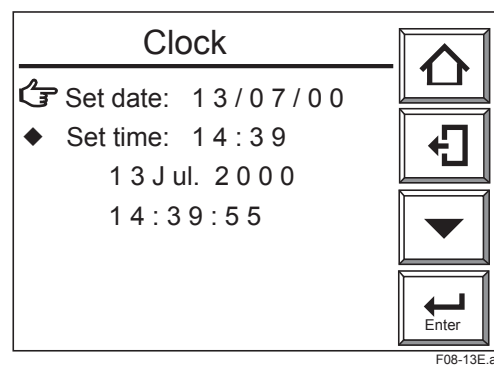

Figure 8.13 Clock Display

### 8.6.2 Setting Periods over which Average Values Are Calculated and Periods over which Maximum and Minimum Values Are Monitored

The equipment enables the display of oxygen concentration average values and maximum and minimum values under measurement (see Section 10.1, later in this manual).

The following section describes how to set the periods over which oxygen concentration average values are calculated and maximum and minimum values are monitored.

**Procedure**

- 1) From the Basic panel display touch [Setup] key, and the Execution/Setup display appears.
- 2) Select the "Commissioning" and the Commissioning display appears.
- 3) Select the "Others" then Averaging. The display of Figure 8.14 appears.
- 4) Select the "Set period over which average is calculated" and numerical entry display appears. To set 3 hours, enter 003. Entry range is 1 to 255 hours.
- 5) Select the "Set period over which maximum and minimum is stored" and numerical entry display appears. To set 48 hours, enter 048. Entry range is 1 to 255 hours.

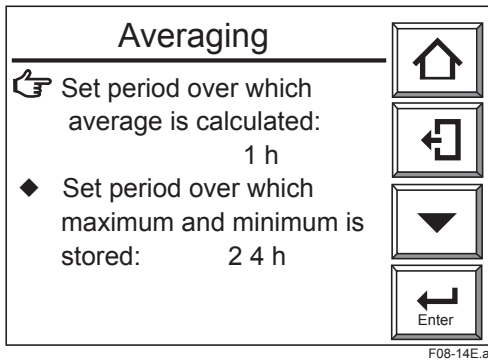

**Figure 8.14** Setting Average Value Calculation Periods and Maximum and Minimum Value Monitoring Periods

**Default Values**

“Set period over which average is calculated” is set to 1hr, and “Set period over which maximum and minimum is stored” is set to 24 hrs prior factory shipment or after data initialization.. .

**8.6.3 Setting Fuels**

**Input Parameters**

The analyzer calculates the moisture content contained in exhaust gases. The following sets forth the fuel parameters necessary for calculation and their entries. The moisture quantity may be mathematically expressed by:

$$\begin{aligned} \text{Moisture quantity} &= \frac{\text{(water vapor caused by combustion and water vapor contained in the exhaust gas)} + \text{(water vapor contained in air for combustion)}}{\text{actual exhaust gas (including water vapor) per fuel}} \times 100 \\ &= (Gw + Gw1)/G \times 100 \\ &= \frac{Gw + (1.61 \times Z \times m \times Ao)}{Go + Gw + [(m - 1) Ao + (1.61 \times Z \times m \times Ao)]} \times 100 \quad \text{..... Equation 1} \\ &\doteq \frac{\boxed{Gw} + (1.61 \times \boxed{Z} \times m \times \boxed{Ao})}{\boxed{X} + \boxed{Ao} \times m} \times 100 \quad \text{..... Equation 2} \end{aligned}$$

where,

$\boxed{Ao}$ : Theoretical amount of air per unit quantity of fuel, m<sup>3</sup>/kg (or m<sup>3</sup>/m<sup>3</sup>) ... ② in Table 8.9

G: Actual amount of exhaust gas (including water vapor) per unit quantity of fuel, m<sup>3</sup>/kg (or m<sup>3</sup>/m<sup>3</sup>)

$\boxed{Gw}$ : Water vapor contained in exhaust gas per unit quantity of fuel (by hydrogen and moisture content in fuel), m<sup>3</sup>/kg (or m<sup>3</sup>/m<sup>3</sup>) ..... ① in Table 8.9

Gw1: Water vapor contained in exhaust gas per unit quantity of fuel (moisture content in air), m<sup>3</sup>/kg (or m<sup>3</sup>/m<sup>3</sup>)

Go: Theoretical amount of dry exhaust gas per unit quantity of fuel, m<sup>3</sup>/kg (or m<sup>3</sup>/m<sup>3</sup>)

m: Air ratio

$\boxed{X}$ : Fuel coefficient determined depending on low calorific power of fuel, m<sup>3</sup>/kg (or m<sup>3</sup>/m<sup>3</sup>) ..... ③ in Table 8.9

$\boxed{Z}$ : Absolute humidity of the atmosphere, kg/kg ..... Figure 8.16

Siki08-2E.ai

Fill in the boxes with fuel parameters in Equation 2 above to calculate the moisture content. Use Ao, Gw and X shown in Table 8.9. If there are no appropriate fuel data in Table 8.9, use the following equations for calculation. Find the value of “Z” in Equations 1 and 2 using Japanese Industrial Standards JIS B 8222. If a precise measurement is not required, obtain the value of “Z” using a graph for the absolute humidity indicated by a dry and wet bulb hygrometer.

- **For liquid fuel**

Amount of water vapor in exhaust gas ( $G_w$ ) =  $(1/100) \{1.24 (9h + w)\}$  ( $m^3/kg$ )

Theoretical amount of air ( $A_o$ ) =  $12.38 \times (HI/10000) - 1.36$  ( $m^3/kg$ )

Low calorific power = HI

X value =  $(3.37 / 10000) \times H_x - 2.55$  ( $m^3/kg$ )

where, HI: low calorific power of fuel

h: Hydrogen in fuel (weight percentage)

w: Moisture content in fuel (weight percentage)

Hx: Same as numeric value of HI

- **For gas fuel**

Amount of water vapor in exhaust gas ( $G_w$ ) =  $(1/100) \{(h_2) + 1/2 \sum y (C_x H_y) + w_v\}$  ( $m^3/m^3$ )

Theoretical amount of air ( $A_o$ ) =  $11.2 \times (HI/10000)$  ( $m^3/m^3$ )

Low calorific power = HI

X value =  $(1.05 / 10000) \times H_x$  ( $m^3/m^3$ )

where, HI: low calorific power of fuel

C<sub>x</sub>H<sub>y</sub>: Each hydrocarbon in fuel (weight percentage)

h<sub>2</sub>: Hydrogen in fuel (weight percentage)

w<sub>v</sub>: Moisture content in fuel (weight percentage)

Hx: Same as numeric value of HI

- **For solid fuel**

Amount of water vapor in exhaust gas ( $G_w$ ) =  $(1/100) \{1.24 (9h + w)\}$  ( $m^3/kg$ )

Theoretical amount of air ( $A_o$ ) =  $1.01 \times (HI / 1000) + 0.56$  ( $m^3/kg$ )

Low calorific power = HI =  $H_h - 25 (9h + w)$  (kJ/kg)

X value =  $1.11 - (0.106 / 1000) \times H_x$  ( $m^3/m^3$ )

where, w: Total moisture content in use (weight percentage)

h: Hydrogen content (weight percentage)

The average hydrogen content of coal mined in Japan, which is a dry ash-free type, is 5.7 percent. Accordingly, "h" may be expressed mathematically by:

$$h = 5.7 \left[ \frac{100 - (w + a)}{100} \right] \times \frac{(100 - w)}{(100 - w_1)}$$

where, a: Ash content (%)

w<sub>1</sub>: Moisture content (%), analyzed on a constant humidity basis

H<sub>h</sub>: Higher calorific power of fuel (kJ/kg)

HI: Low calorific power of fuel (kJ/kg)

Hx: Same numeric value of HI

F08-15E.ai

Figure 8.15 Calculation Formula

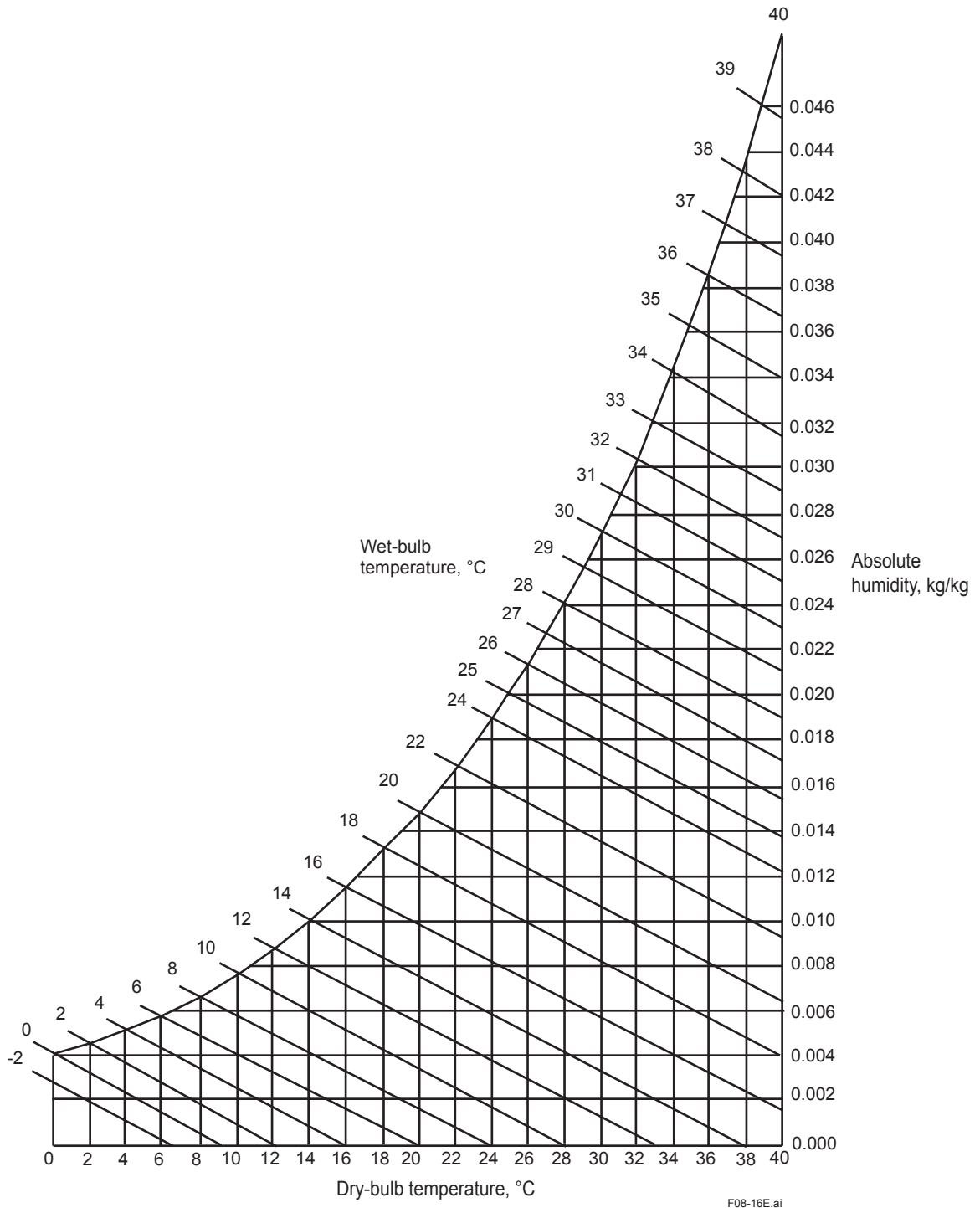

Figure 8.16 Absolute Humidity of Air

Table 8.9 Fuel Data

● For liquid fuel

Fuel properties Type			Specific weight kg/l	Chemical component (weight percentage)							Calorific power kJ/kg		Theoretical amount of air for combustion m³/kg	Amount of combustion gas m³/kg					X value	
				C	H	O	N	S	w	Ash content	Higher order	Lower order		CO <sub>2</sub>	H <sub>2</sub> O	SO <sub>2</sub>	N <sub>2</sub>	Total		
Kerosene			0.78~ 0.83	85.7	14.0	—	—	0.5	0.0	0.0	0.0	46465	43535	11.4	1.59	1.56	0.00	9.02	12.17	0.96
Light oil			0.81~ 0.84	85.6	13.2	—	—	1.2	0.0	0.0	0.0	45879	43032	11.2	1.59	1.47	0.00	8.87	11.93	0.91
A	Heavy oil class 1	No.1	0.85~ 0.88	85.9	12.0	0.7	0.5	0.5	0.3	0.05	0.05	45544	42739	10.9	1.60	1.34	0.00	8.61	11.55	0.89
		No.2	0.83~ 0.89	84.6	11.8	0.7	0.5	2.0	0.4	0.05	0.05	45125	42320	10.8	1.58	1.32	0.01	8.53	11.44	0.86
B	Heavy oil class 2		0.90~ 0.93	84.5	11.3	0.4	0.4	3.0	0.5	0.05	0.05	43827	41274	10.7	1.58	1.27	0.02	8.44	11.31	0.77
C	Heavy oil class 3	No.1	0.93~ 0.95	86.1	10.9	0.5	0.4	1.5	0.5	0.1	0.1	43952	41441	10.7	1.61	1.22	0.01	8.43	11.27	0.79
		No.2	0.94~ 0.96	84.4	10.7	0.5	0.4	3.5	0.5	0.1	0.1	43116	40646	10.5	1.58	1.20	0.02	8.32	11.12	0.72
		No.3	0.92~ 1.00	86.1	10.9	0.5	0.4	1.5	0.6	0.1	0.1	43660	41190	10.7	1.61	1.22	0.01	8.43	11.27	0.77
		No.4	0.94~ 0.97	83.0	10.5	0.5	0.4	3.5	2.0	0.1	0.1	43032	40604	10.3	1.55	1.18	0.02	8.18	10.93	0.72
													②		①					③

● For gas fuel

Type	Fuel properties Specific weight kg/m <sup>3</sup>	Chemical component (weight percentage)							Calorific power kJ/m <sup>3</sup>		Theoretical amount of air for combustion m <sup>3</sup> /m <sup>3</sup>	Combustion product, m <sup>3</sup> / m <sup>3</sup>				X value
		CO	H <sub>2</sub>	CO <sub>2</sub>	CH <sub>2</sub>	C <sub>m</sub> H <sub>n</sub>	O <sub>2</sub>	N <sub>2</sub>	Higher order	Lower order		CO <sub>2</sub>	H <sub>2</sub> O	N <sub>2</sub>	Total	
Coke oven gas	0.544	9.0	50.5	2.6	25.9	3.9	0.1	8.0	20428	18209	4.455	0.45	1.10	3.60	5.15	0.46
Blast furnace gas	1.369	25.0	2.0	20.0	—	—	—	53.0	3391	3349	0.603	0.45	0.02	1.01	1.48	0.08
Natural gas	0.796	—	—	2.0	88.4	3.2	0.1	4.2	37883	34074	9.015	0.98	1.88	7.17	10.03	0.86
Propane	2.030	C <sub>3</sub> H <sub>8</sub> 90%, C <sub>4</sub> H <sub>10</sub> 10%							102055	93976	24.63	3.10	4.10	19.5	26.7	2.36
Butane	2.530	C <sub>3</sub> H <sub>8</sub> 10%, C <sub>4</sub> H <sub>10</sub> 90%							125496	115868	30.37	3.90	4.90	24.0	32.8	2.91
(Gases)		(Molecular Formula)														
Oxygen	1.43	O <sub>2</sub>							—	—	—	—	—	—	—	—
Nitrogen	1.25	N <sub>2</sub>							—	—	—	—	—	—	—	
Hydrogen	0.09	H <sub>2</sub>							12767	10758	2.390	—	1.0	1.89	2.89	0.27
Carbon monoxide	1.25	CO							12642	12642	2.390	1.0	—	1.89	2.89	0.32
Carbon dioxide	1.96	CO <sub>2</sub>							—	—	—	—	—	—	—	
Methane	0.72	CH <sub>4</sub>							39750	35820	9.570	1.0	2.0	7.57	10.6	0.90
Ethane	1.34	C <sub>2</sub> H <sub>6</sub>							69638	63744	16.74	2.0	3.0	13.2	18.2	1.60
Ethylene	1.25	C <sub>2</sub> H <sub>4</sub>							62991	59060	14.35	2.0	2.0	11.4	15.4	1.48
Propane	1.97	C <sub>3</sub> H <sub>8</sub>							99070	91255	23.91	3.0	4.0	18.9	25.9	2.29
Butane	2.59	C <sub>4</sub> H <sub>10</sub>							128452	118623	31.09	4.0	5.0	24.6	33.6	2.98
											②		①			③

**Procedure**

To make a fuel setting, follow these steps:

- (1) Press the [Setup] key in the Basic panel display to display the Execution/Setup display.
- (2) Select the “Commissioning” in the Execution/Setup display. The Commissioning display then appears.
- (3) Select the “Others” in that display and then the Fuel setup shown in Figure 8.17.
- (4) Choose the “Theoretical air quantity required” and the “Contents of moisture in exhaust gas” in turn. The numeric-data entry display then appears. Enter numeric data using the numeric keys.
- (5) Choose “more” in the Fuel setup display. The Fuel setup shown in Figure 8.18 then appears.
- (6) Set the numeric data to the “Value of the X coefficient” and then to the “Absolute humidity of the atmosphere”.
- (7) Choose “finished” to return to the display shown in Figure 8.17.

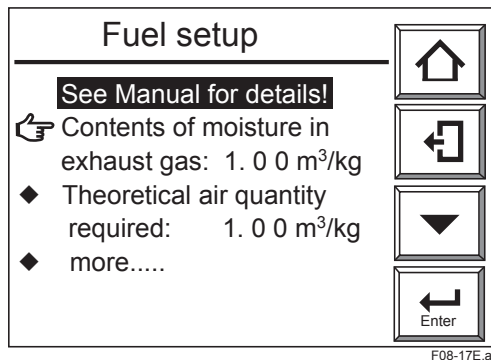

Figure 8.17 Fuel Setup

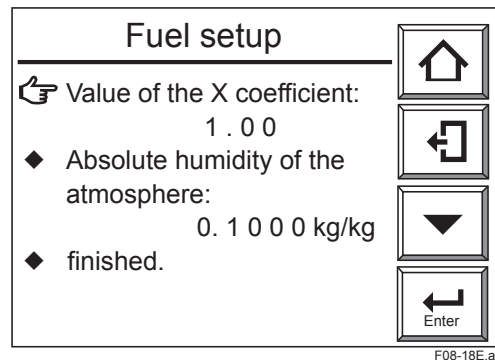

Figure 8.18 Fuel Setup



**Default Values**

When the analyzer is delivered, or if data are initialized, default, parameter settings are as shown in Table 8.10.

**Table 8.10 Default Settings for Fuel Values**

Item	Default setting
Amount of water vapor in exhaust gas	0.00 m <sup>3</sup> /kg (m <sup>3</sup> )
Theoretical amount of air	1.00 m <sup>3</sup> /kg (m <sup>3</sup> )
X value	1.00
Absolute humidity of the atmosphere	0.0 kg/kg

**8.6.4 Setting Purging**

Purging is to remove condensed water in the calibration gas pipe by supplying a span calibration gas for a given length of time before warm-up of the detector. This prevents cell breakage during calibration due to condensed water in the pipe.

Open the solenoid valve for the automatic calibration span gas during purging and after the purge time has elapsed, close the valve to start warm-up.

Purging is enabled when the cell temperature is 100 °C or below upon power up and the purge time is set in the range of 1 to 60 minutes.

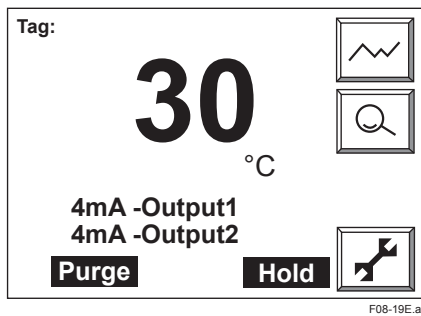

**Figure 8.19 Display during Purging**

**Procedure**

Set the purging time as follows:

- (1) Press the [Setup] key in the Basic panel display to display the Execution/Setup display.
- (2) Select the “Commissioning” in the Execution/Setup display. The Commissioning display then appears.
- (3) Select the “Others” in that display and the Others display then appears, as shown in Figure 8.20.
- (4) Select the “Purging”. The purging time setting display appears, as shown in Figure 8.21.
- (5) Point to the “Purging time” and press the [Enter] key. Then the display for selecting purging time appears.
- (6) Enter the desired numeric value from the numeric-data entry display. The allowable input ranges from 0 to 60 minutes.

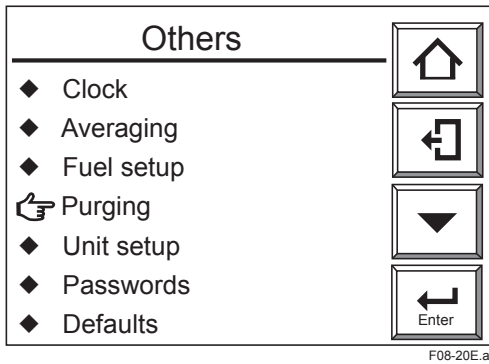

Figure 8.20 Other Settings

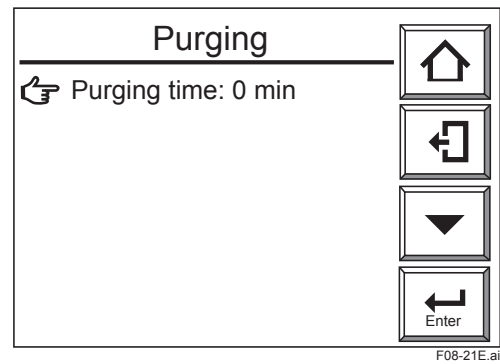

Figure 8.21 Purging Display

### 8.6.5 Setting Passwords

Unauthorized access to lower level menu displays from the Execution/Setup display can be protected by passwords. You can set separate passwords for Calibration, Blow back, and Maintenance and for Commissioning

#### Proceed as follows:

- 1) From the Basic panel display touch the [Setup] key, and the Execution/Setup display appears.
- 2) Select the "Commissioning" , and the Commissioning display appears.
- 3) Select the "Others" then the "Passwords". The display shown in Figure 8.22 appears. First set the password for Calibration, Blow back, and Maintenance.
- 4) Select "Calibration, Blow back, and Maintenance".
- 5) A text entry display appears. Enter password as up to 8 alphanumeric characters.
- 6) You can enter a password for Commissioning by the same procedure.
- 7) Record the passwords and look after them carefully.

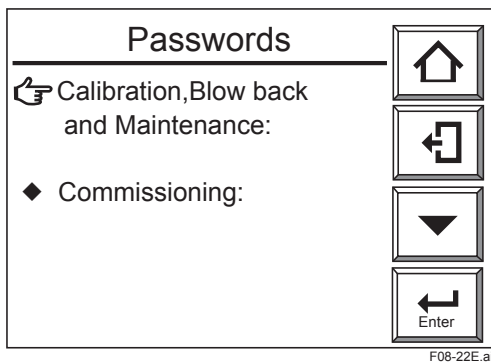

Figure 8.22 Passwords Display

#### <Default setting>

The passwords are not set as shipped from factory. If you reset initialize the parameters, and password settings are deleted.

If you forget a password, select "Commissioning" in the Execution/Setup display, and enter "MOON". By doing so, you can enter the Commissioning display only. Then display the Passwords and verify the set passwords.



# 9. Calibration

## 9.1 Calibration Briefs

### 9.1.1 Principle of Measurement

This section sets forth the principles of measurement with a zirconia oxygen analyzer before detailing calibration.

A solid electrolyte such as zirconia allows the conductivity of oxygen ions at high temperatures. Therefore, when a zirconia-plated element with platinum electrodes on both sides is heated up in contact with gases having different oxygen partial pressures on each side, the element shows the action of the concentration cell. In other words, the electrode in contact with a gas with a higher oxygen partial pressure acts as a negative electrode. As the gas comes in contact with the zirconia element in this negative electrode, oxygen molecules in the gas acquire electrons and become ions. Moving in the zirconia element, they eventually arrive at the positive electrode on the opposite side.

There, the electrons are released and the ions return to the oxygen molecules. This reaction is indicated as follows:



The electromotive force E (mV) between the two electrodes, generated by the reaction, is governed by Nernst's equation as follows:

$$E = -RT/nF \ln P_x/P_a \dots\dots\dots \text{Equation (1)}$$

where,

R: Gas constant

T: Absolute temperature

n: 4

F: Faraday's constant

Px: Oxygen concentration in a gas in contact with the positive zirconia electrode (%)

Pa: Oxygen concentration in a gas in contact with the negative zirconia electrode (%)

Assuming the zirconia element is heated up to 750°C, then we obtain equation (2) below.

$$E = -50.74 \log \frac{P_x}{P_a} \dots\dots\dots \text{Equation (2)}$$

Siki09E.ai

With this analyzer, the sensor (zirconia element) is heated up to 750°C, so Equation (2) is valid. At that point, the relationship as in Figure 9.1 is effected between the oxygen concentration of the sample gas in contact with the positive electrode and the electromotive force of the sensor (cell), where a comparison gas of air is used on the negative electrode side.

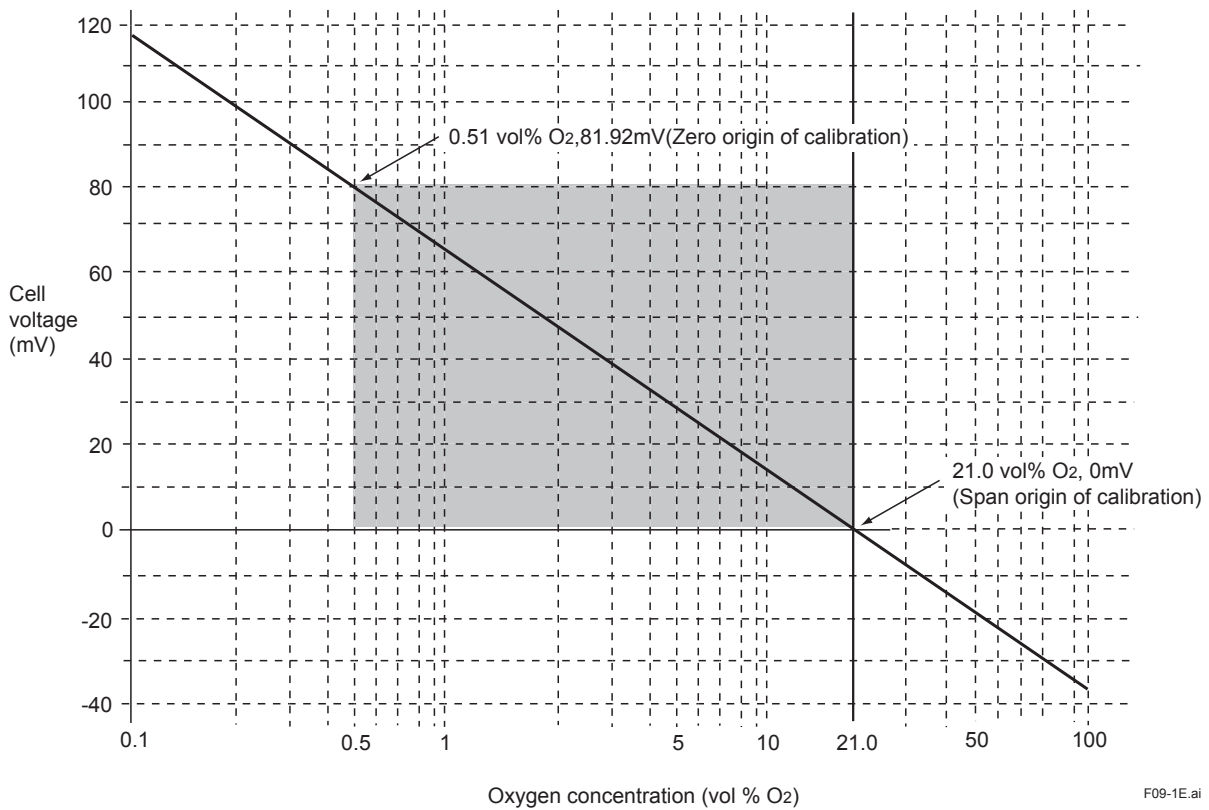

**Figure 9.1 Oxygen concentration in a Sample Gas vs Cell Voltage (21 vol%O<sub>2</sub> Equivalent)**

The measurement principles of a zirconia oxygen analyzer have been described above. However, the relationship between oxygen concentration and the electromotive force of a cell is only theoretical. Usually, in practice, a sensor shows a slight deviation from the theoretical value. This is the reason why calibration is necessary. To meet this requirement, an analyzer calibration is conducted so that a calibration curve is obtained, which corrects the deviation from the theoretical cell electromotive force.

### 9.1.2 Calibration Gas

A gas with a known oxygen concentration is used for calibration. Normal calibration is performed using two different gases: a zero gas of low oxygen concentration and a span gas of high oxygen concentration. In some cases, only one of the gases needs to be used for calibration. However, even if only one of the gases is normally used, calibration using both gases should be done at least once.

The zero gas normally used has an oxygen concentration of 0.95 to 1.0 vol%O<sub>2</sub> with a balance of nitrogen gas (N<sub>2</sub>). The span gas widely used is clean air (at a dew-point temperature below -20 °C and free of oily mist or dust, as in instrument air).

For best accuracy, as the span gas use oxygen whose concentration is near the top of the measurement range, in a nitrogen mixture.

### 9.1.3 Compensation

The deviation of a measured value from the theoretical cell electromotive force is checked by the method in Figure 9.2 or 9.3.

Figure 9.2 shows a two-point calibration using two gases: zero and span. Cell electromotive forces for a span gas with an oxygen concentration  $p_1$  and a zero gas with an oxygen concentration  $p_2$  are measured while determining the calibration curve passing through these two points. The oxygen concentration of the sample gas is determined from this calibration curve. In addition, the calibration curve corrected by calibration is compared with the theoretical calibration curve for determining the zero correction ratio represented by  $B/A \times 100 (\%)$  on the basis of A, B and C shown in Figure 9.2 and a span correction ratio of  $C/A \times 100 (\%)$ . If the zero correction ratio exceeds the range of  $100 \pm 30\%$  or the span correction ratio becomes larger than  $0 \pm 18\%$ , calibration of the sensor becomes impossible.

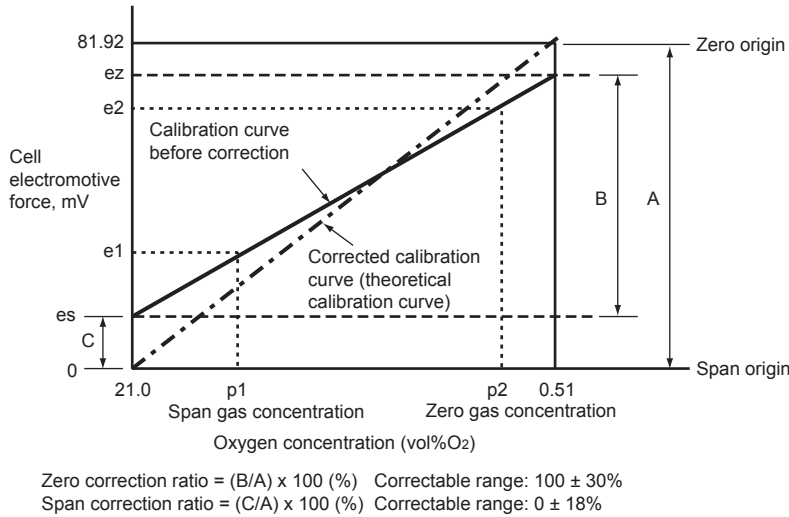

F09-2E.ai

**Figure 9.2 Calculation of a Two-point Calibration Curve and Correction Ratios using Zero and Span Gases**

Figure 9.3 shows a one-point calibration using only a span gas. In this case, only the cell electromotive force for a span gas with oxygen concentration  $p_1$  is measured. The cell electromotive force for the zero gas is carried over from a previous measurement to obtain the calibration curve. The principle of calibration using only a span gas also applies to the one-point calibration method using a zero gas only.

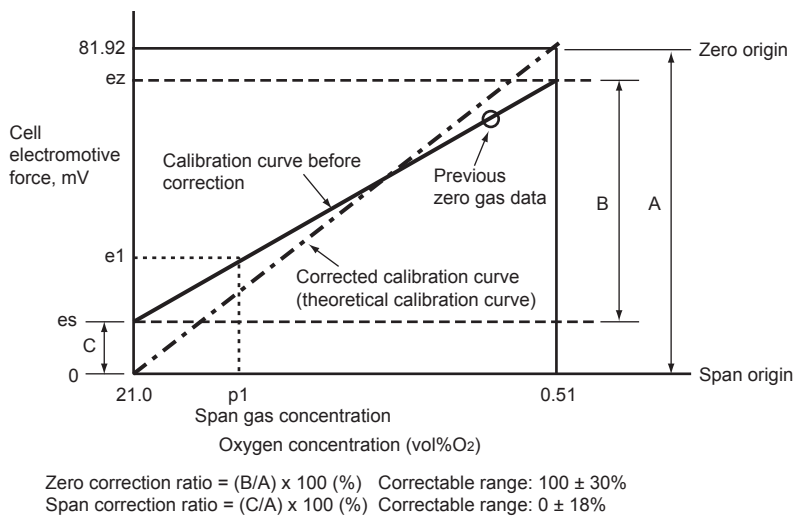

F09-3E.ai

**Figure 9.3 Calculation of a One-point Calibration Curve and Correction Ratios using a Span Gas**

---

### 9.1.4 Characteristic Data from a Sensor Measured During Calibration

During calibration, calibration data and sensor status data (listed below) are acquired. However, if the calibration is not properly conducted (an error occurs in automatic or semi-automatic calibration), these data are not collected in the current calibration.

These data can be observed by selecting the [Detailed-data] key from the Basic panel display. For an explanation and the operating procedures of individual data, consult Subsection 10.1.1, Detailed-data Display.

#### (1) Record of span correction ratio

Recorded the past ten span correction ratios.

#### (2) Record of zero correction ratio

Recorded the past ten zero correction ratios.

#### (3) Response time

You can monitor the response time provided that a two-point calibration has been done in semi-automatic or automatic calibration.

#### (4) Cell's internal resistance

The cell's internal resistance gradually increases as the cell (sensor) deteriorates. You can monitor the values measured during the latest calibration. However, these values include the cell's internal resistance and other wiring connection resistance. So, the cell's degrading cannot be estimated from these values only.

When only a span calibration has been made, these values will not be measured, and previously measured values will remain.

#### (5) Robustness of a cell

The robustness of a cell is an index for predicting the remaining life of a sensor and is expressed in a number on four levels.

---

## 9.2 Calibration Procedures

### NOTE

---

Calibration should be made under normal operating conditions (if the probe is connected to a furnace, the analyzer will undergo calibration under the operating conditions of the furnace). To make a precise calibration, conduct both zero and span calibrations.

---

### 9.2.1 Calibration Setting

The following sets forth the required calibration settings:

#### Mode

**There are three calibration modes available:**

- (1) Manual calibration which allows zero and span calibrations or either one manually in turn;
- (2) Semi-automatic calibration which lets calibration start with the touchpanel or a contact input, and undergoes a series of calibration operations following preset calibration interval and stabilization time.
- (3) Automatic calibration which is carried out automatically following preset calibration interval.

**Calibrations are limited by the following mode selection:**

- **When Manual calibration is selected:**

Manual calibration only can be conducted. (This mode does not allow semi-automatic calibration with a contact input nor automatic calibration even when its start-up time has reached.)

- **When Semi-automatic calibration is selected:**

This mode enables manual and semi-automatic calibrations to be conducted. (The mode, however, does not allow automatic calibration even when its start-up time has reached.)

- **When Automatic calibration is selected:**

This calibration can be conducted in any mode.

To execute this calibration, follow these steps:

- (1) Select the [Setup] key from the Basic panel display to display the Execution/Setup display. Then select "Maintenance" from the Execution/Setup display.
- (2) Select "Calibration setup" from the Maintenance display. Then select "Mode" from the Calibration setup display (see Figure 9.4).  
Now you can select "Manual", "Semi\_Auto", or "Auto" calibration.



### Calibration Procedure

Select both span and zero calibrations or span calibration only or zero calibration only. Usually select span and zero calibrations.

Select "Points" from the Calibration setup display and then you can select "Both," "Span" or "Zero" (see Figure 9.5).

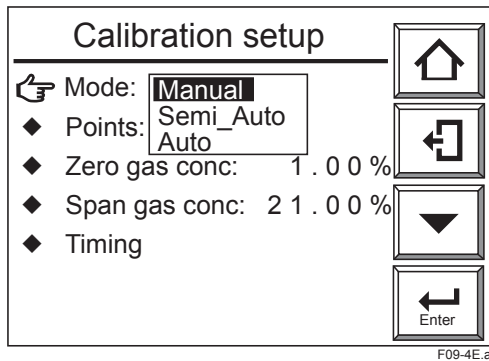

Figure 9.4 Calibration Setup display

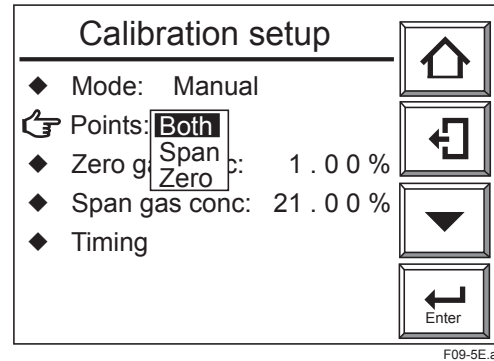

Figure 9.5 Calibration Setup display

### Zero gas Concentration

Set the oxygen concentration for zero calibration. Enter the oxygen concentration for the zero gas in the cylinder used in the following procedures:

Select "Zero gas conc" from the Calibration setup display. The numeric-data entry display then appears. Enter the desired oxygen concentration for the zero calibration. (The zero gas set ranges from 0.3 to 100 vol%O<sub>2</sub>.)

Enter 00098 for an oxygen concentration of 0.98 vol%O<sub>2</sub>.

### Span gas Concentration

Set the oxygen concentration for span calibration. If instrument air is used as the span gas, enter 21%O<sub>2</sub>.

Select "Span gas conc" from the Calibration setup display. Enter the desired span gas oxygen concentration from the numeric-data entry display.

(The span gas set ranges from 4.5 to 100 vol%O<sub>2</sub>.)

Enter 02100 for an oxygen concentration of 21 vol%O<sub>2</sub>.

Instrument air is here defined as dry air with a dew-point temperature of no higher than -20°C. If the dew-point temperature is higher than -20°C, use a hand-held oxygen analyzer to measure the actual oxygen concentration.

When using the ZO21S Standard Gas Unit (for use of the atmospheric air as a span gas), use a hand-held oxygen analyzer to measure the actual oxygen concentration, and then enter it.

### CAUTION

- When the instrument air supply is to be used as span gas, cool it to -20°C below dew point to remove moisture, oil mist and dust from the air.
- If you do not do this to purify the air, then the accuracy of the calibration may be affected.

### Setting Calibration Time

• **When the calibration mode is in manual:**

First set the “Hold time” (output stabilization time). This indicates the time required from the end of calibration to entering a measurement again. This time, after calibration, the sample gas enters the sensor to set the time until the output returns to normal. The output remains held after completing the calibration operation until the hold (output stabilization) time elapses. The calibration time set ranges from 00 minutes, 00 seconds to 60 minutes, 59 seconds. For more details, consult Section 8.2, Output Hold Setting.

• **When the calibration mode is in semi-automatic:**

Set the hold (output stabilization) time and calibration time. The calibration time is the time required from starting the flow of the calibration gas to reading out the measured value. The set calibration time is effective in conducting both zero and span calibrations. The calibration-time set ranges from 00 minutes, 00 seconds to 60 minutes, 59 seconds. Figure 9.6 shows the relationship between the calibration time and hold (output stabilization) time.

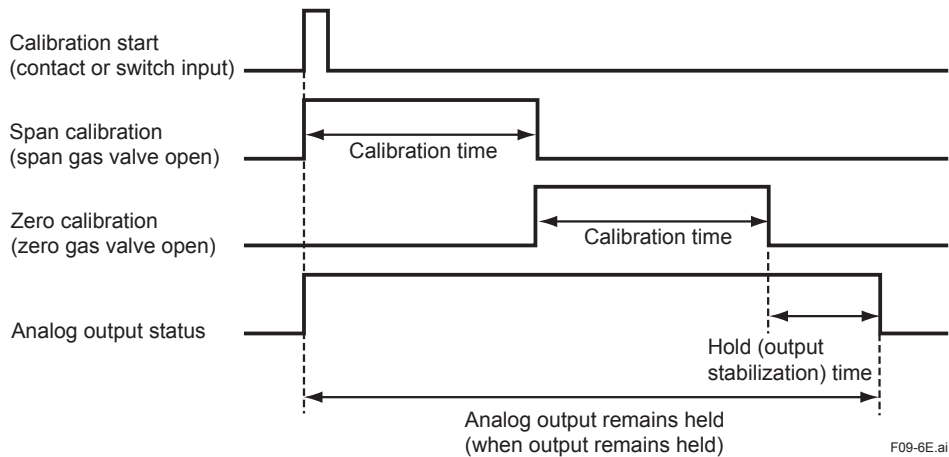

**Figure 9.6 Calibration and Hold Time Settings**

• **When the calibration mode is in automatic:**

In addition to the above Hold (output stabilization) time and Calibration time, set the Interval, Start date, and Start time.

Interval means the calibration intervals ranging from 000 days, 00 hours to 255 days, 23 hours.

Set the first calibration day and the start-calibration time to the “Start date” and “Start time” respectively. For example, to start the first calibration at 1:30 p.m. on March 25, 2001, enter 25/03/01 to the start date and 13 hours, 30 minutes to the start time, following the steps below:

- (1) Select the “Calibration timing” display. A panel display as shown in Figure 9.7 appears.
- (2) Select each item for the calibration to display the numeric-data entry display. Enter the desired numeric values for the calibration.

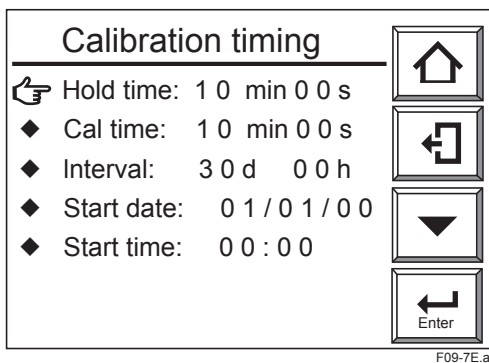

**Figure 9.7 Calibration Timing Display**

---

## NOTE

When setting calibration timing requirements, bear the following precautions in mind:

- If the calibration interval is shorter than the sum of hold (output stabilization) time plus calibration time, the second calibration start time will conflict with the first calibration. In such a case, the second calibration will not be conducted. (When both zero and span calibrations are to be performed, the calibration time is double that required for a single (zero or span) calibration.)
  - For the same reason, if the calibration start time conflicts with manual calibration or semi-automatic calibration, the current calibration will not be conducted.
  - If the calibration time conflicts with maintenance service or blow back operations, calibration will start after completing the maintenance service or blow back operations (see Subsection 8.2.1, earlier in this manual).
  - If 000 days, 00 hours are set for the calibration intervals, only the first calibration will be conducted; a second or later calibration will not be conducted.
  - If a past date is set to the calibration start day, no calibration will be conducted.
- 

### 9.2.2 Default Values

When the analyzer is delivered, or if data are initialized, the calibration settings are by default, as shown in Table 9.1.

**Table 9.1**      **Default Settings for Calibration**

Item	Default Setting
Calibration mode	Manual
Calibration procedure	Span - zero
Zero gas (oxygen) concentration	1.00%
Span gas (oxygen) concentration	21.00%
Hold (output stabilization) time	10 minutes, 00 seconds
Calibration time	10 minutes, 00 seconds
Calibration interval	30 days, 00 hours
Start date	01 / 01 / 00
Start time	0:00

### 9.2.3 Calibration

#### NOTE

- Perform calibration under normal working conditions (e.g. continuous operation with sensor mounted on furnace).
- Perform both Span and Zero calibration for best resultant accuracy.
- When instrument air is used for the span calibration, remove the moisture from the instrument air at a dew-point temperature of -20°C and also remove any oily mist and dust from that air.
- If dehumidifying is not enough, or if foul air is used, the measurement accuracy will be adversely affected.

#### Manual Calibration

For manual calibration, consult Section 7.12, Calibration, earlier in this manual.

#### Semi-automatic Calibration

To start calibration, follow these steps:

- (1) Press the [Setup] key in the Basic panel display to display the Execution/Setup display. Then select the "Calibration" in the Execution/Setup display. The Calibration display shown in Figure 9.8 appears.
- (2) Select the "Semi-auto calibration" to display the Semi-auto calibration display shown in Figure 9.9.
- (3) Select the "Start calibration". The display shown in Figure 9.10 appears, and then start calibration.

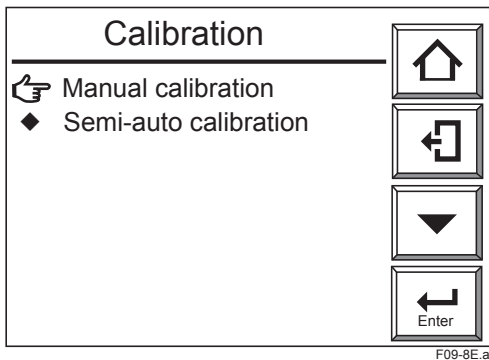

Figure 9.8 Calibration Display

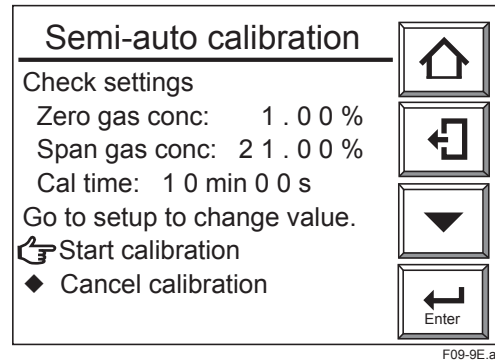

Figure 9.9 Semi-auto Calibration Display

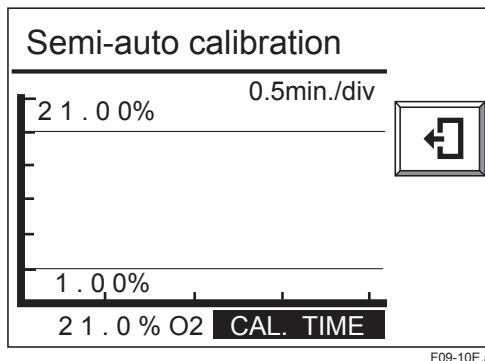

Figure 9.10 Semi-auto Calibration Display

---

To start calibration using a contact input, follow these steps:

- (1) Make sure that Calibration start has been selected in the "Input contacts" display (see Section 8.5, earlier in this manual).
- (2) Apply an input contact to start calibration.

To stop calibration midway, follow these steps:

- (1) Press the [Reject] key. If this key is pressed midway during calibration, the calibration will stop and the hold (output stabilization) time will be set up.
- (2) Press the [Reject] key once again to return to the Basic panel display and the analyzer will be in normal measurement.

### **Automatic Calibration**

No execution operations are required for automatic calibration. Automatic calibration starts in accordance with a preset start day and time. Calibration is then executed at preset intervals.

### **NOTE**

---

Before starting Semi-automatic calibration or Automatic calibration, operate the calibration gas solenoid valves and adjust calibration gas flow to  $600 \pm 60$  ml/min.

---

# 10. Other Functions

## 10.1 Detailed-data Display

Press the [Detailed-data] key on the Basic panel display to view the detailed operation data as shown in Figure 10.1.

Pressing the [▼] or [▲] key, you can advance the page or go back to your desired page.

- Detailed-data display

There are nine panel displays for viewing detailed data. The following briefly describes each data item.

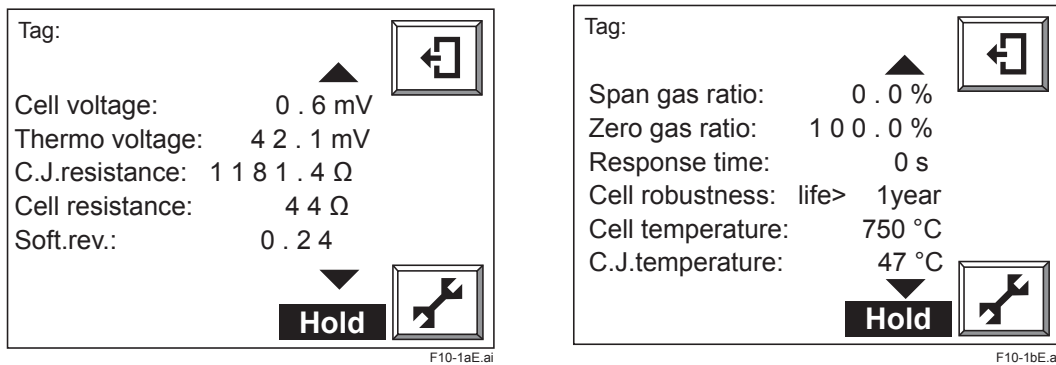

Figure 10.1 Detailed-data Display

### 10.1.1 Cell Voltage

The cell (sensor) voltage will be an index to determine the amount of degradation of the sensor. The cell voltage corresponds to the oxygen concentration currently being measured. If the indicated voltage approximates the ideal value (corresponding to the measured oxygen concentration), the sensor will be assumed to be normal.

The ideal value of the cell voltage (E), when the oxygen concentration measurement temperature is controlled at 750°C, may be expressed mathematically by:

$$E = -50.74 \log (P_x/P_a) \text{ [mV]}$$

where, P<sub>x</sub>: Oxygen concentration in the sample gas

P<sub>a</sub>: Oxygen concentration in the reference gas, (21%O<sub>2</sub>)

Table 10.1 shows oxygen concentration versus cell voltage.

Table 10.1 Oxygen Concentration Vs. Cell Voltage, (cell temperature: 750 °C)

%O <sub>2</sub>	0.1	0.2	0.3	0.4	0.5	0.6	0.7	0.8	0.9
mv	117.83	102.56	93.62	87.28	82.36	78.35	74.95	72.01	69.41
%O <sub>2</sub>	1	2	3	4	5	6	7	8	9
mv	67.09	51.82	42.88	36.54	31.62	27.61	24.21	21.27	18.67
%O <sub>2</sub>	10	21.0	30	40	50	60	70	80	90
mv	16.35	0	-7.86	-14.2	-19.2	-23.1	-26.5	-29.5	-32.1
%O <sub>2</sub>	100								
mv	-34.4								

### 10.1.2 Thermocouple Voltage

The cell temperature is measured with a Type K (chromel-alumel) thermocouple. The thermocouple cold junction is located in the detector terminal box. The cell temperature and the thermocouple voltage (including the voltage corresponding to the cold junction temperature) are displayed.

### 10.1.3 Cold Junction Resistance (C.J. Voltage)

The ZR22 Detector measures the cold junction temperature using an RTD (Pt 1000). (The earlier model of ZO21D uses transistors to measure the cold junction temperature.) If detector "ZR22" is selected in the Basic setup display, the RTD resistance values will be displayed. If the ZO21D is selected, the transistor voltage will be displayed.

### 10.1.4 Cell's Internal Resistance

A new cell (sensor) indicates its internal resistance of 200 Ω maximum. As the cell degrades, so will the cell's internal resistance increase. The degradation of the cell cannot be evaluated just by changes in cell's internal resistance, however. Those changes in the cell's internal resistance are just a guide to the extent the cell is degrading. The updated values obtained during the calibration are displayed.

### 10.1.5 Software Revision

The revision (number) of the software installed is displayed.

### 10.1.6 Span gas and Zero gas Correction Ratios

These are used to check for degradation of the sensor (cell). If the correction ratio is beyond the limits as shown in Figure 10.2, the sensor should no longer be used.

These ratios can be found by calculating the data as shown below.

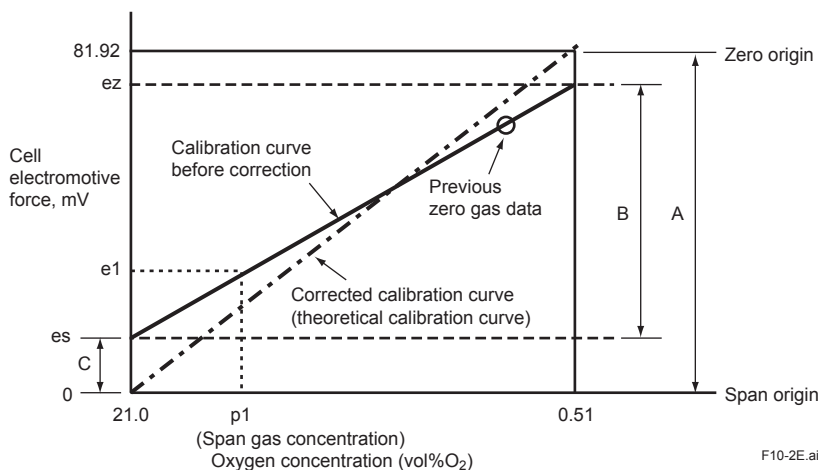

Zero gas correction ratio =  $(B/A) \times 100$  (%)    Correctable range:  $100 \pm 30\%$   
 Span gas correction ratio =  $(C/A) \times 100$  (%)    Correctable range:  $0 \pm 18\%$

Figure 10.2    Span gas and Zero gas Correction Ratios

### 10.1.7 Cell Response Time

The cell's response time is obtained in the procedure shown in Figure 10.3. If only either a zero or span calibration has been carried out, the response time will not be measured just as it will not be measured in manual calibration.

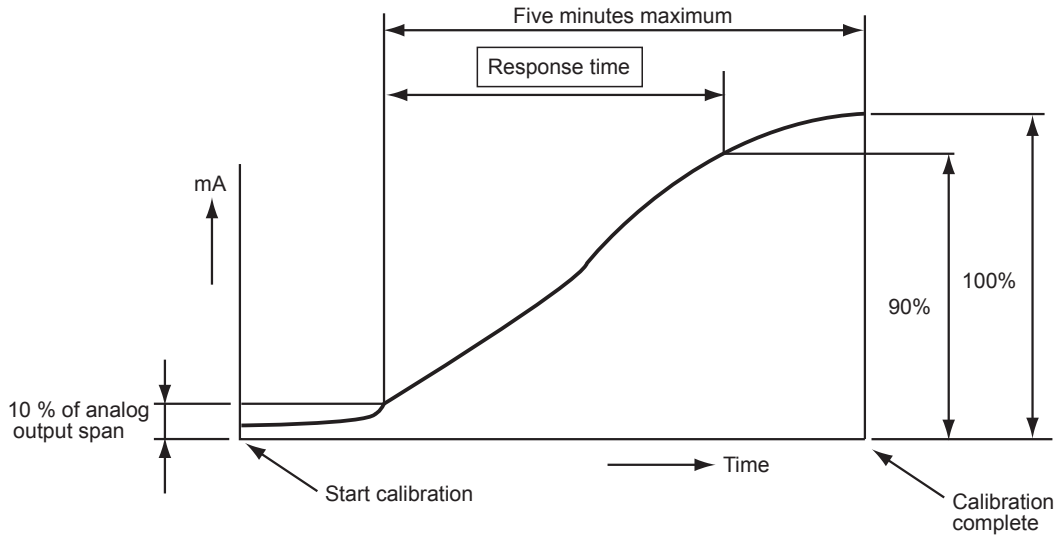

The response time is obtained after the corrected calibration curve has been found. The response time is calculated, starting at the point corresponding to 10 % of the analog output up to the point at 90 % of the analog output span. That is, this response time is a 10 to 90 % response.

F10-3E.ai

Figure 10.3 Typical response time characteristic

### 10.1.8 Robustness of a Cell

The robustness of a cell is an index for predicting the remaining life of a sensor and is expressed as one of four time periods during which the cell may still be used:

- (1) more than a year
- (2) more than six months
- (3) more than three months
- (4) less than one month

The above four time periods are tentative and only used for preventive maintenance, not for warranty of the performance.

This cell's robustness can be found by a total evaluation of data involving the response time, the cell's internal resistance, and calibration factor. However, if a zero or span calibration was not made, the response time cannot be measured. In such a case, the response time is not used as a factor in evaluating the cell's robustness.

### 10.1.9 Cell Temperature

This displays the cell (sensor) temperature, which is determined from the thermocouple electromotive force (e.m.f.) and cold junction temperature. Normally it is 750°C.



### 10.1.10 C. J. Temperature

This indicates the detector terminal box temperature, which compensates for the cold junction temperature for a thermocouple measuring the cell temperature. When the ZR22 Detector is used, the maximum C. J. temperature will be 150°C. If the terminal box temperature exceeds this, take measures to shield the terminal box from heat radiation.

The maximum C. J. temperature varies depending on the type of detector.

### 10.1.11 Maximum Oxygen Concentration

The maximum oxygen concentration and the time of its occurrence during the period specified in the Averaging display are displayed. After the present monitoring interval has elapsed, the maximum oxygen concentration that has been displayed so far will be cleared and a new maximum oxygen concentration will be displayed. If the setup period of time is changed, the current maximum oxygen concentration will be displayed (for more details, see Subsection 8.6.2 earlier in this manual).

### 10.1.12 Minimum Oxygen Concentration

The minimum oxygen concentration and the time of its occurrence during the period specified in the Averaging display are displayed. If the setup period elapses, the minimum oxygen concentration that has been displayed so far will be cleared and a new minimum oxygen concentration will be displayed. If the setup period of time is changed, the current minimum oxygen concentration will be displayed (for more details, see Subsection 8.6.2 earlier in this manual).

### 10.1.13 Average Oxygen Concentration

The average oxygen concentration during the periods over which average values are calculated is displayed. If the setup period elapses, the average oxygen concentration that has been displayed so far will be cleared and a new average oxygen concentration will be displayed. If the setup period of time is changed, the current average oxygen concentration will be displayed (for more details, see Subsection 8.6.2 earlier in this manual).

### 10.1.14 Heater On-Time Ratio

The probe sensor is heated to and maintained at 750°C. When the sample gas temperature is high, the amount of heater ON-time decreases.

### 10.1.15 Time

The current date and time are displayed. These are backed up with built-in batteries, so the clock continues the run even if the power is switched off.

### 10.1.16 History of Calibration Time

The calibration-conducted dates and times, and span gas and zero gas correction ratios for the past ten calibrations are stored in memory.

### 10.1.17 Power Supply Voltage

For the temperature control for the heater of the detector to work best, you should set the power supply voltage and frequency appropriately, as the control parameters are based on this. Set the AC supply voltage to "Low" if supply is 140 V AC or less, and to "High" if it is 180 V AC or more.

### 10.1.18 Power Frequency

Set the AC supply frequency setting appropriately — "Low" for 50 Hz, and "High" for 60 Hz.

## 10.2 Trend Graph

Press the [Graph display] key in the Basic panel display to switch to the graph display. This will help grasp the measured-value trend. Touching anywhere on the graph display will return to the Basic panel display. To set the Trend graph display, follow the steps in Subsection 10.2.1.

### 10.2.1 Setting Display Items

- (1) Press the [Setup] key in the Basic panel display to display the Execution/Setup display. Select the "Maintenance" in the Execution/Setup display.
- (2) Select the "Display setup" in the Maintenance display.
- (3) Select the "Trend graph" in the Display setup display. The Trend graph display shown in Figure 10.4 appears.
- (4) Select the "Parameter: Oxygen" in the Trend graph display. Then select the desired display item shown in Table 10.2.

**Table 10.2** Trend Graph Display Items

Selected item	Description
Oxygen concentration	Oxygen concentration graph under measurement
Output 1	If this equipment is for the oxygen analyzer, the trend graph will be an oxygen concentration graph.
Output 2	If this equipment is for the oxygen analyzer, the trend graph will be an oxygen concentration graph.

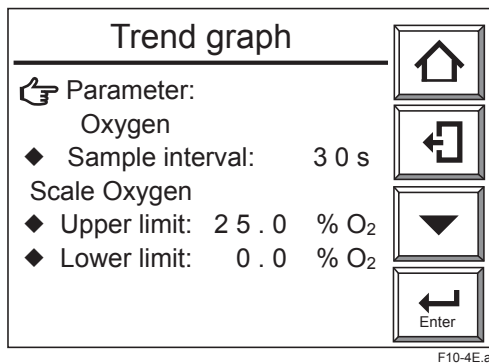

**Figure 10.4** Trend Graph Display

### 10.2.2 Sampling Interval

To plot a graph, set the sampling period for the measurement data.

This graph allows the plotting of 60 data items on one division on the time axis. So, if you set a ten-second sampling interval, one division corresponds to 600 seconds (Figure 10.5). The allowable sampling intervals range from 1 to 30 seconds. If you set a one-second sampling interval, the axis of the abscissas then corresponds to five minutes.

If you set it to 30 seconds, the axis of the abscissas then corresponds to 150 minutes.

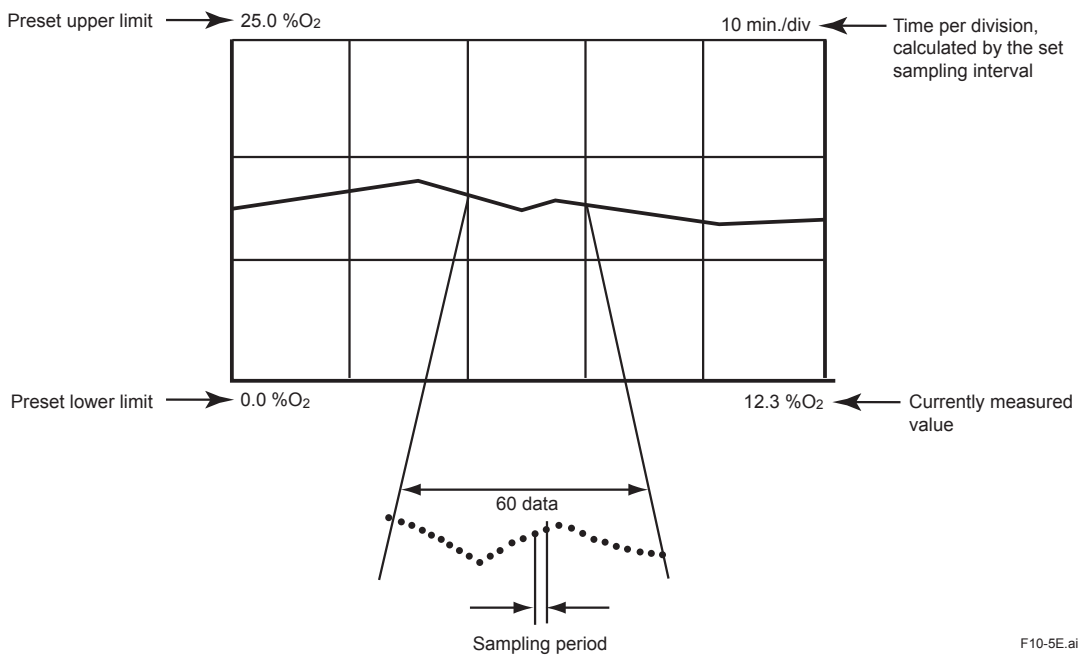

Figure 10.5 Plotting Graph for Sampling Interval

F10-5E.ai

### 10.2.3 Setting Upper and Lower Limit Values on Graph

Set upper and lower limit values on the graph in the following procedure:

Press “Upper limit” in the Trend graph display. The numeric-data entry key appears. Enter the upper limit value. Also enter the lower limit value in the same way. The allowable settings for both upper limit and lower limit values range from 0 to 100%O<sub>2</sub>.

### 10.2.4 Default Setting

When the analyzer is delivered, or if data are initialized, the set data are by default, as shown in Table 10.3.

Table 10.3 Default Values for Graph Setting

Item Default	Value
Parameter	Oxygen concentration
Sample interval	30 seconds
Upper limit	25%O <sub>2</sub>
Lower limit	0%O <sub>2</sub>

### NOTE

If a rapid change in the measured value occurs during sampling, no sampled data are plotted on the graph. Use the graph indication tentatively. Check the output current for accurate data.

## 10.3 Other Display-related Functions

### 10.3.1 Auto-Return Time

On the Execution/Setup display or lower level menu displays, if no keys are touched for a preset time, the Auto return time, then the display will automatically revert to the Basic panel display. The “Auto return time” can be set in the range 0 to 255 minutes. If it is set to 0, then the display does not automatically revert. By default, the “Auto return time” is set to 0 (zero).

Set the Auto return time in the following procedure:

- (1) On the Basic panel display, touch the [Setup] key to display the Execution/Setup display, then select “Maintenance”. Select “Display setup”, then “Auto return time”.
- (2) The numerical entry display appears for you to enter the desired Auto return time. To set an Auto return time of one hour, enter 060.
- (3) If you set 0, then the Auto return function does not operate.

### 10.3.2 Entering Tag Name

You can attach a desired tag name to the equipment. To attach it, follow these steps:

- (1) Select the [Setup] key in the Basic panel display to display the Execution/Setup display. Then select the “Maintenance” in the Execution/Setup display.
- (2) Select the “Display setup” in the Maintenance display.
- (3) Select the “Display item” in the Display setup display. The display shown in Figure 10.6 then appears.
- (4) Select the “Tag name” in the Display item display. The text-data entry display then appears.
- (5) Enter up to 12 alphanumeric characters including codes for the desired tag name.

### 10.3.3 Language Selection

You can select a display language from among English, Japanese, German and French. The display language is set to the one specified in the purchase order when the analyzer is shipped from the factory.

To select the language you want, follow these steps:

- (1) On the Basic panel display, touch the [Setup] key to display the Execution/Setup display.
- (2) Select the “Maintenance”, then “Display setup”.
- (3) Select the “Language” and the dropdown selection (Figure 10.7) allows you to select the desired language.

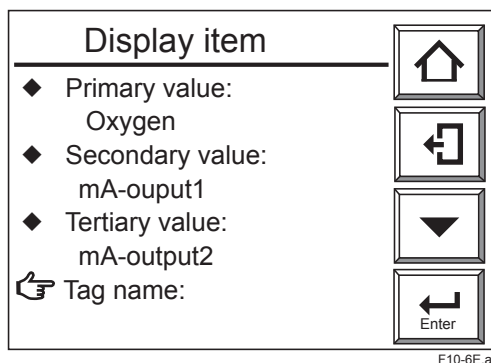

Figure 10.6 Display Item Display

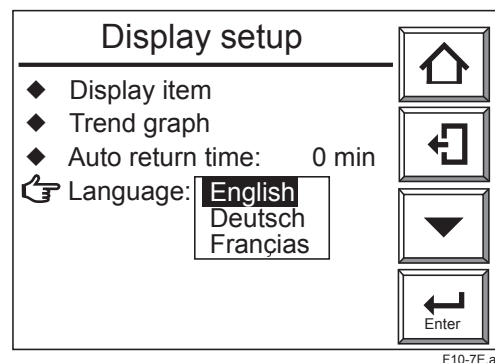

Figure 10.7 Selecting the Display Language

## 10.4 Blow Back

This section explains the parameter settings for performing blow back.

### 10.4.1 Mode of Blow back

There are three modes of blow back operation: no function, semi-automatic, and automatic. Blow back is not performed when the mode is set to “No function”. In “Semi\_Auto” mode, blow back can be started by key operation on the display or by a contact input signal, and then sequentially performed at a preset blow back time and hold time. In “Auto” mode, blow back is automatically performed at preset intervals. The following restrictions apply:

When “No function” is selected, blow back is not performed.

When “Semi\_Auto” is selected, semi-automatic blow back can be performed. (Blow back does not start at Auto blow back start time.)

When “Auto” is selected, blow back can be performed in either “Auto” or “Semi\_Auto” mode.

#### <Setting Procedure>

- (1) From the Basic panel display, touch [Setup] key; on the Execution/Setup display which appears, select “Maintenance”.
- (2) On the Maintenance display, select “Blow back setup” and the Mode selection pull down allows you to select between “No function”, “Semi\_Auto” and “Auto” (see Figure 10.8).

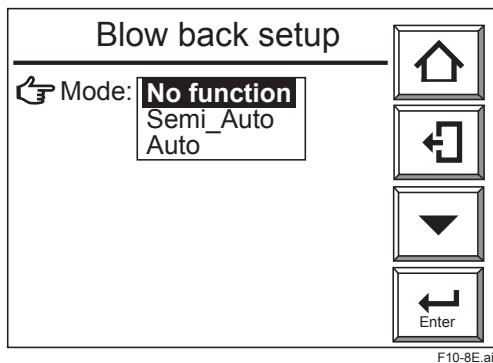

Figure 10.8 Blow back setup Display

### 10.4.2 Operation of Blow back

Figure 10.9 shows a timing chart for the operation of blow back. To execute blow back with a contact input, use a contact input with an ON-time period of one to 11 seconds. Once blow back starts, a contact output repeatedly opens and closes at an interval of approximately 10 seconds during the preset blow back time. After the blow back time elapses, the analog output remains held at the preset status until the hold time elapses (refer to Section 8.2, earlier in this manual).

As the hold (output stabilization) time, set the time until the sample gas is returned to the sensor and output returns to the normal operating conditions, after completing blow back operations.

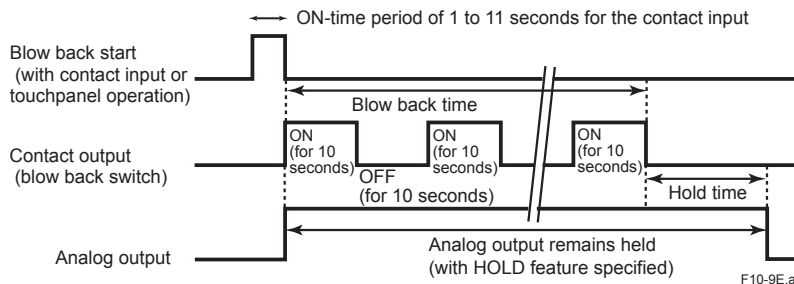

Figure 10.9 Operation of Blow back

### 10.4.3 Setting Output Hold Time and Blow back Time

If the blow back mode is in “No function”, the output “Hold time” and “Blow back time” are not displayed. If you select “Hold time”, the numeric-data entry display appears. Enter the desired “Hold time” (output stabilization time) from 00 minutes, 00 seconds to 60 minutes, 59 seconds.

When you select “Blow back time”, the numeric-data entry display appears. Enter the desired “Blow back time” from 00 minutes, 00 seconds to 60 minutes, 59 seconds.

### 10.4.4 Setting Interval, Start Date, and Start Time

The “Interval” is the time to execute blow back. Display the numeric-data entry panel display to set the desired interval from 000 days, 00 hours to 255 days, 59 hours.

For the “Start date” and “Start time”, set the date when the blow back is first executed and the time when to start the blow back, respectively. If you want to execute the first blow back, for example, at 4:00 p.m. on March 25, 2001, enter 25/ 03/ 01 for the Start date and 16:00 for the Start time.

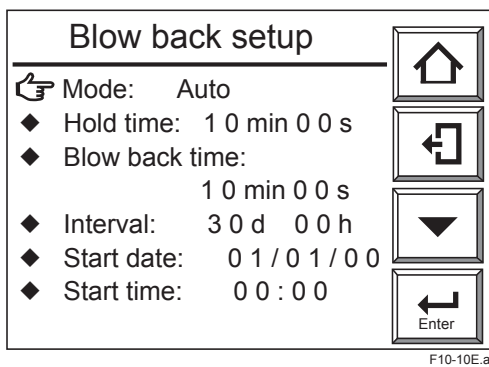

Figure 10.10 Blow back Setup Display

In the Blow back setup display shown in Figure 10.10, if you choose “Mode: No function” or “Semi\_Auto”, the Interval, Start date, and Start time for these are not displayed.

### NOTE

- If the blow back is executed with a contact input, it must be preset in the Contact input setting (for more details, see Section 8.5, earlier in this manual).
- In Section 8.4, Contact Output Setting, earlier in this manual, set the contact used as the blow back switch beforehand.
- Do not set any other function for the contact used as the blow back switch. Otherwise, blow back may be activated when the contact is closed by any other function.
- No blow back is executed during calibration or maintenance service. If automatic blow back reaches the preset start time during calibration or maintenance service, blow back will be executed after completing the calibration or maintenance service and after the equipment returns to the measurement mode.
- If automatic blow back reaches the preset start time during semi-automatic blow back, the current automatic blow back will not be executed.
- If you set the blow back interval at 000 days, 00 hours, only the first blow back is then executed. No subsequent blow backs will be executed.
- If a past date is set for the Start time, no blow back will be executed.

### 10.4.5 Default Setting

When the analyzer is delivered, or if data are initialized, the blow back settings are by default, as shown in Table 10.4.

**Table 10.4 Blow back Default Setting**

Item	Default setting
Mode	No function ("invalid")
Hold time	10 minutes, 00 seconds
Blow back time	10 minutes, 00 seconds
Interval	30 days, 00 hours
Start date	01/ 01/00
Start time	0:00

## 10.5 Parameter Initialization

Parameter settings can be initialized to the factory default settings. Initialization can be done for all parameters or for individual parameters. The parameters that can be initialized and their defaults are listed in Table 10.5.

**To initialize the set data, follow these steps:**

- (1) On the Basic panel display, touch the [Setup] key to display the Execution/Setup display.
- (2) Select "Commissioning", next "Others" then "Defaults". A display like Figure 10.11. appears.
- (3) Select the desired item to be initialized then a display like Figure 10.12 appears.  
Select "Defaults start" then initialization starts.

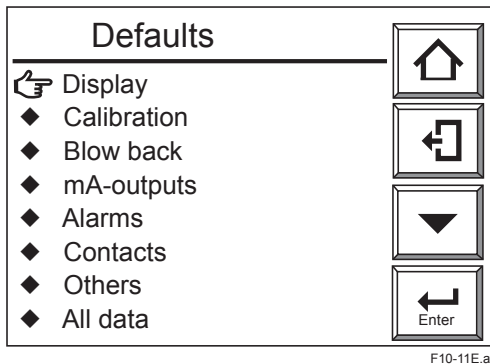

**Figure 10.11 Defaults Display**

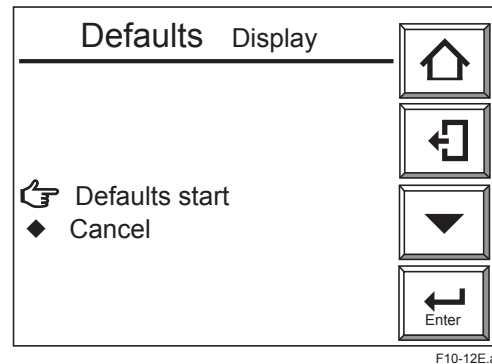

**Figure 10.12 Initialization Start Display**

### CAUTION

Do not turn off the power during initialization. Otherwise, initialization will not be performed properly.

**Table 10.5 Initialization Items and Default Values**

Item	Initialization Parameter		Default setting
Equipment selection	Type of equipment		Not initialized
	Detector		ZR22
	Sample gas		Wet gas
Displayed data	Display item	1st display item	Oxygen concentration
		2nd display item	Current output 1
		3rd display item	Current output 2
		Tag name	Deleted
	Trend graph	Parameter	Oxygen concentration
		Sampling interval	30 seconds
		Upper limit (graph)	25 vol%O <sub>2</sub>
		Lower limit (graph)	0 vol%O <sub>2</sub>
Automatic return time		0 min.	
Language		Not initialized	
Calibration data	Calibration setting	Mode	Manual
		Calibration procedure	Span - zero
		Zero gas concentration	1.00 vol%O <sub>2</sub>
		Span gas concentration	21.00 vol%O <sub>2</sub>
		Output hold time	10 min., 00 sec. (Semi_Auto)
		Calibration time	10 min., 00 sec. (Semi_Auto)
		Interval	30 days, 00 hr. (Auto)
		Start date	01/01/00 (Auto)
Blow back	Blow back setting	Mode	No function (invalid)
		(Output) hold time	10 min., 00 sec.
		Blow back time	10 min., 00 sec.
		Interval	30 days, 00 hr.
		Start date	01/01/00
		Start time	0:00
Current output data	mA-output 1 mA-output 2	Parameter	Oxygen concentration
		Min. oxygen concentration	0 vol%O <sub>2</sub>
		Max. oxygen concentration	25 vol%O <sub>2</sub>
		Output damping constant	0 sec.
		Output mode	Linear
	Output hold setting	Warm-up	4 mA
		Set value of Warm-up	4 mA
		Maintenance	Previous value held
		Set value of Maintenance	4 mA
		Calibration, blow back	Previous value held
		Set value of Calibration, blow back	4 mA
		Error	Preset value held
		Set value of Error	3.4 mA

Continue to the next page



Item	Initialization Parameter		Default setting	
Alarm data	Alarm setting	Parameter	Oxygen concentration	
		Hysteresis	0.1 vol%O <sub>2</sub>	
		Delayed action of alarm contact	3 seconds	
	Alarm set value	High-high alarm	OFF	
		Alarm value of High-high alarm	100 vol%O <sub>2</sub>	
		High limit alarm	OFF	
		Alarm value of High limit alarm	100 vol%O <sub>2</sub>	
		Low limit alarm	OFF	
		Alarm value of Low limit alarm	0 vol%O <sub>2</sub>	
		Low-low alarm	OFF	
Alarm value of Low-low alarm	0 vol%O <sub>2</sub>			
Contacts	Output contact 1	Alarm	OFF	
		Other settings	Warm-up	ON
			Output range now being switched	OFF
			Now calibrating	OFF
			Now maintenance servicing	ON
			Blow back	OFF
			High limit temp. alarm	OFF
			Calibration gas press. drop	OFF
		Gas leak detection	OFF	
		Contact output action	Open	
	Output contact 2	Alarm	OFF	
		Other settings	Warm-up	OFF
			Output range switching	OFF
			Now calibrating	ON
			Now maintenance servicing	OFF
			Blow back	OFF
			High limit temp. alarm	OFF
			Calibration gas press. drop	OFF
		Gas leak detection	OFF	
		Contact output action	Closed	
	Output contact 3	Alarm	High-high alarm	OFF
			High limit alarm	ON
			Low limit alarm	ON
			Low-low alarm	OFF
			Calibration coefficient (correction ratio) alarm	OFF
			Startup power stabilization timeout	OFF
			Error	OFF
		Other settings	OFF	
Contact output		Closed		
Output contact 4		Alarm	Error	ON
	Other settings	OFF		
	Contact output	Closed (Fixed)		
Input contact 1 Input contact 2	Function	OFF		
	Action	Closed		

Continue to the next page

Item	Initialization Parameter		Default setting
Other data	Average value/ Maximum and minimum values	Average-value calculation	One hour
		Intervals over which max. and min. values are monitored	24 hours
	Fuel set value	Amount of water vapor in exhaust gas	0.00 m <sup>3</sup> /kg (m <sup>3</sup> )
		Theoretical amount of air	1.00 m <sup>3</sup> /kg (m <sup>3</sup> )
		X value	1.00
		Absolute humidity of atmosphere	0.0 kg/kg
	Password		Deleted

## 10.6 Reset

Resetting enables the equipment to restart. If the equipment is reset, the power is turned off and then back on. In practical use, the power remains on, and the equipment is restarted under program control. Resetting will be possible in the following conditions:

- (1) Error 1 – if the cell voltage is defective
- (2) Error 2 – if a temperature alarm occurs
- (3) Error 3 – if the A/D converter is defective
- (4) Error 4 – if an EEPROM write error occurs

For details on error occurrence, consult Chapter 12, Troubleshooting, later in this manual.

If any of the above problems occurs, the equipment turns off the power to the detector heater. To cancel the error, reset the equipment following the steps below, or turn the power off and then back on.

### NOTE

Make sure that before resetting or restarting the power that there is no problem with the detector or converter.

If a problem arises again after the resetting, turn the power off and troubleshoot the problem by consulting the Troubleshooting chapter later in this manual.

To reset the equipment, follow these steps:

- (1) Press the [Setup] key in the Basic panel display to display the Execution/Setup display.
- (2) Choose "Reset". The Reset display shown in Figure 10.13 appears.
- (3) Choose "Start reset" and then press the [Enter] key to reset the equipment and the equipment will then be in its warm-up state.

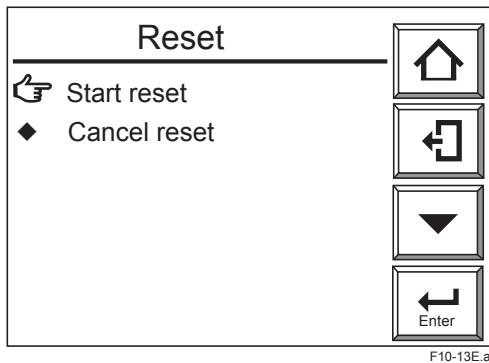

Figure 10.13 Reset Display

## 10.7 Handling of the ZO21S Standard Gas Unit

The following describes how to flow zero and span gases using the ZO21S Standard Gas Unit. Operate the ZO21S Standard Gas Unit, according to the procedures that follow.

### 10.7.1 Standard Gas Unit Component Identification

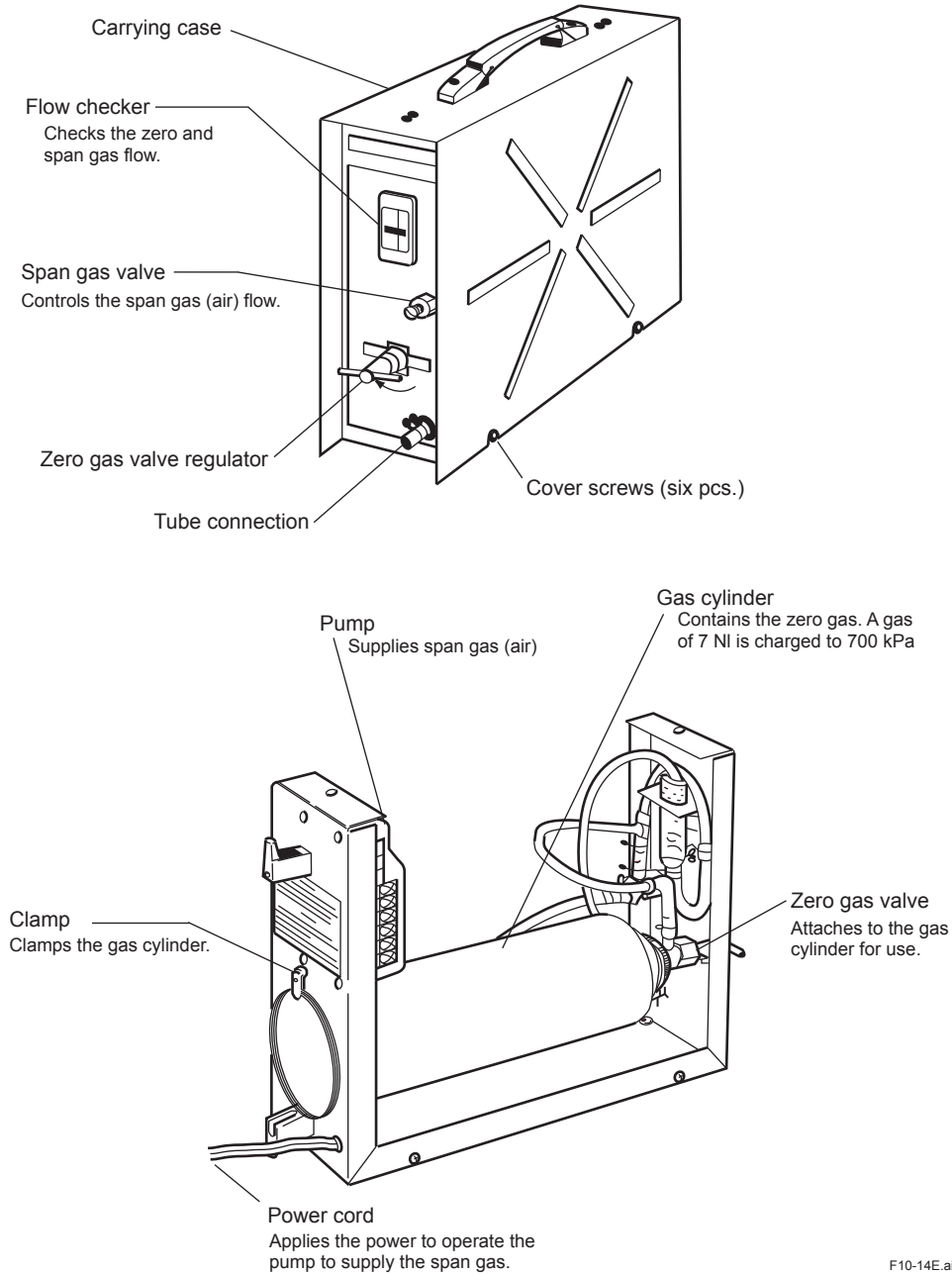

Figure 10.14 Standard Gas Unit Component Identification

F10-14E.ai

## 10.7.2 Installing Gas Cylinders

Each ZO21S Standard Gas Unit comes with six zero gas cylinders including a spare. Each gas cylinder contains 7-liters of gas with a 0.95 to 1.0 vol%O<sub>2</sub> (concentration varies with each cylinder) and nitrogen, at a pressure of 700 kPaG (at 35°C).

The operating details and handling precautions are also printed on the product. Please read them beforehand.

To install the gas cylinder, follow these steps:

- (1) Attach the zero gas valves onto the gas cylinder. First, turn the valve regulator of the zero gas valves counterclockwise to completely retract the needle at the top from the gasket surface. Maintaining the valve in this position, screw the valve mounting into the mouthpiece of the gas cylinder. (If screw connection is proper, you can turn the screw manually. Do not use any tool.) When the gasket comes in contact with the mouthpiece of the gas cylinder and you can no longer turn it manually, tighten the lock nut with a wrench.
- (2) Remove the carrying case from the standard gas unit. The case is attached to the unit with six screws. So, loosen the screws and lift them off.
- (3) Slide the gas cylinder through the hole in the back of the unit and connect the tube (the piping in the unit) to the valve connections. Insert each tube at least 10 mm to prevent leakage, and secure it using a tube clamp.
- (4) Attach the gas cylinder to the case. Extend the valve regulator of the zero gas valves through the hole in the front panel of the unit and secure the bottom of the cylinder with the clamp.
- (5) Take note of the oxygen concentration of the sealed gas indicated on the gas cylinder and replace the carrying case. Enter the oxygen concentration of the sealed gas, following instructions on the converter display. Also check that no piping is disconnected.

Thus, the work of installing a gas cylinder is completed. However, gases in the cylinders cannot immediately flow out after these procedures. To discharge the gases, it is necessary for the needle in the zero gas valves to puncture a hole in the gas cylinder.

For this operation, see Subsection 10.7.3.

## 10.7.3 Calibration Gas Flow

### <Preparation before calibration>

- (1) To operate the standard gas unit, place it on a nearly horizontal surface in order to allow the flow check to indicate the precise flow rate. In addition, a power supply for driving the span gas (air) supply pump is required near the unit (the length of the power cord attached to the unit is 2 m). Select a suitable location for the unit near the installation site of the converter.
- (2) Connect the tube connector port of the standard gas unit to the calibration gas inlet of the detector, using a polyethylene resin tube with an outside diameter of 6 mm. Be careful to prevent gas leakage.
- (3) Fully open the stop valve mounted on the calibration gas inlet of the detector.
- (4) Enter the oxygen concentration of the sealed gas (noted from the cylinder) into the converter. Also check that the oxygen concentration of the span gas is correctly set (21 vol%O<sub>2</sub> for clean air). When using the ZO21S Standard Gas Unit (for use of the atmospheric air as a span gas), use a hand-held oxygen analyzer to measure the actual oxygen concentration, and then enter it.

<Flow of span gas (air)>

The standard gas unit is used only when manual calibration is employed. Therefore, the timing for flowing span gas (air) is included in the manual calibration procedure described in Subsection 10.7.2. For operation of the converter, see Section 7.12, earlier in this manual.

- (1) When the message “Open span gas valve.” is displayed on the converter display during calibration, plug the power cord into the power supply socket to start the pump of the standard gas unit.
- (2) Next, adjust the flow rate to  $600 \pm 60$  ml/min using the span gas valve “AIR” (the flow check ball stops floating on the green line when the valve is slowly opened). To rotate the valve shaft, loosen the lock nut and turn it using a flat-blade screwdriver. Turning the valve shaft counterclockwise increases the flow rate.
- (3) After adjusting the flow rate, tighten the valve lock nut.
- (4) Select “Valve opened” (to start calibration) in the Manual calibration display shown in Figure 10.15. Check the Trend graph display to see that the measured value is stabilized. Then press the [Enter] key. The Manual calibration display shown in Figure 10.16 appears. Disconnect the power cord to stop the pump.

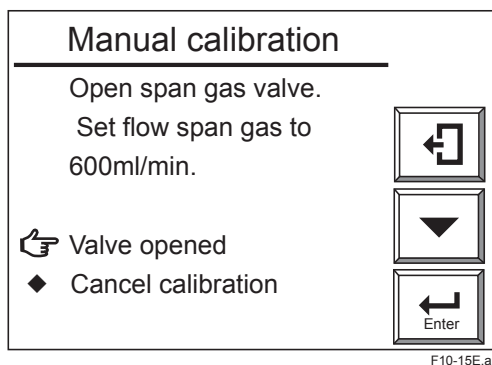

Figure 10.15 Manual Calibration Display

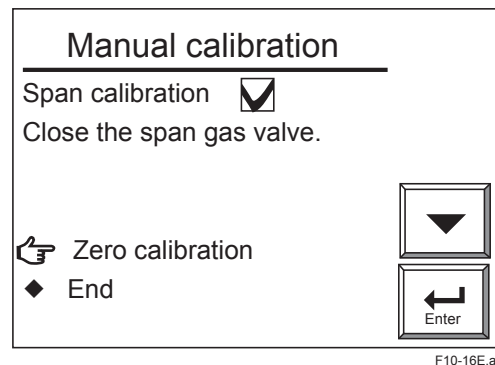

Figure 10.16 Manual Calibration Display

<Flow of zero gas>

Cause a zero gas to flow according to the Manual calibration display shown in Figure 10.17.

- (1) Use the needle of the zero gas valve “CHECK GAS “ to puncture a hole in the gas cylinder installed as described in Subsection 10.7.2. Fully clockwise turn the valve regulator by hand.
- (2) Next, adjust the flow rate to  $600 \pm 60$  ml/min (the flow check ball stops floating on the green line when the valve is slowly opened). Turn the regulator of the zero gas valves back slowly counterclockwise. At that time, the flow rate also decreases as the inner pressure of the gas cylinder decreases. Therefore, monitor the flow check and, when the ball’s position changes greatly, readjust the valve.
- (3) Select “Valve opened” (to start calibration) from the Manual calibration display. Check the Trend graph display to see that the measured value is stabilized. Then press the [Enter] key. The Manual calibration display shown in Figure 10.18 appears. Then stop the zero gas flow immediately. Turn the zero gas valve regulator fully clockwise. If this valve regulator is not properly adjusted, the needle valve will not close completely and a cylinder gas may leak.

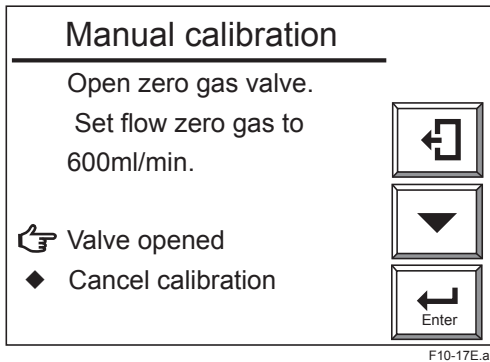

Figure 10.17 Manual Calibration Display

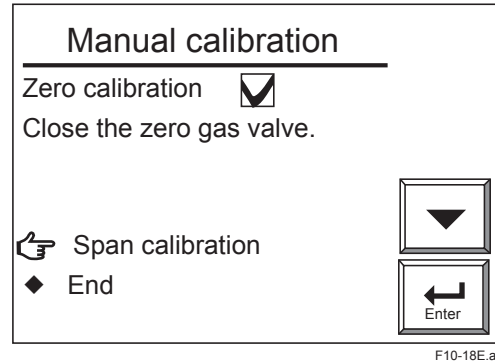

Figure 10.18 Zero gas Calibration Complete (in Manual Calibration Display)

**NOTE**

Be sure not to terminate a calibration in progress because of a shortage of gas in the cylinder. Each gas cylinder is operable for nine minutes or more provided the gas is discharged at the specified rate. Therefore, if your calibration time is estimated at four minutes, you can operate the zero-point calibration twice.

**<Treatment after completion of calibration>**

- (1) Fully close the stop valve mounted on the calibration gas inlet of the detector.
- (2) Remove the tube connecting the detector to the standard gas unit.

 **WARNING**

Store the standard gas unit with the gas cylinder mounted where the ambient temperature does not exceed 40°C. Otherwise, the gas cylinder may explode. Store the spare gas cylinders under the same condition.

## 10.8 Methods of Operating Valves in the ZA8F Flow Setting Unit

The ZA8F Flow Setting Unit is used as a calibration device for a system conforming to System 1. Calibration in such a system is to be manually operated. So, you have to operate the valve of the Flow Setting Unit each time calibration is made (starting and stopping the calibration gas flow and adjusting the flow rate). This applies even if you are using the ZR40H Automatic Calibration Unit. For operation of the converter, see Section 7.12, earlier in this manual.

### 10.8.1 Preparation Before Calibration

To operate the ZA8F Flow Setting Unit, prepare for calibration as follows:

- (1) Check for a complete closing of the zero gas flow setting valve in the unit and open the reducing valve for the zero gas cylinder until the secondary pressure equals sample gas pressure plus approx. 50 kPa (or sample gas pressure plus approx. 150 kPa when a check valve is used, maximum pressure rating is 300 kPa).
- (2) Check that the oxygen concentration of the zero gas and span gas (instrument air 21 vol%O<sub>2</sub>) in the cylinder is set in the converter.

### 10.8.2 Operating the Span Gas Flow Setting Valve

The following description is given assuming that instrument air, the same as the reference gas, is used as the span gas.

- (1) When the display shown in Figure 10.15 appears during calibration, open the span gas flow setting valve of the flow setting unit and adjust the flow rate to 600 ± 60 ml/min. Turn the valve slowly counterclockwise after loosening the lock nut if the valve has a lock nut. To check the flow rate, use the calibration flowmeter. If the sample gas pressure is extremely high, adjust the sample gas pressure to obtain pressures (listed in Table 10.6) ±10%.

**Table 10.6**

Sample gas pressure (kPa)	50	100	150	200	250
Flow rate (mL/min)	500	430	380	350	320

- (2) Adjust the flow rate and select "Valve opened" in the Manual calibration display. Check the Trend graph display to see that the measured value is stabilized. Then press the [Enter] key. The Manual calibration display shown in Figure 10.16 appears.
- (3) Close the span gas flow setting valve to stop the span gas (air) flow. If the valve has a lock nut, be sure to tighten the lock nut to prevent any leakage of the span gas into the sensor during measurement.

### 10.8.3 Operating the Zero Gas Flow Setting Valve

Operate the zero gas flow setting valve during zero-point calibration in the following procedures:

- (1) When the display shown in Figure 10.19 appears during calibration, open the zero gas flow setting valve of the flow setting unit and adjust the flow rate to 600 ± 60 ml/ min. To rotate the valve shaft, if the valve has a lock nut loosen the lock nut and slowly turn it counterclockwise. To check the flow rate, monitor the calibration gas flowmeter. If the sample gas pressure is extremely high, adjust the sample gas pressure to obtain pressures (listed in Table 10.6) ±10%.

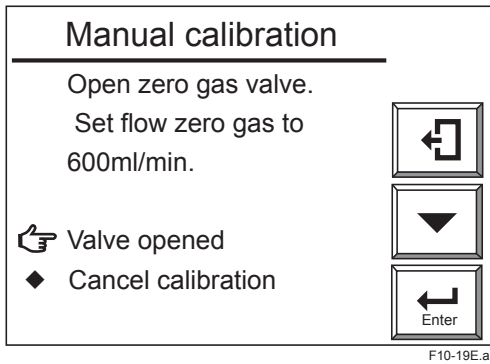

Figure 10.19 Manual Calibration Display

- (2) Adjust the flow rate and select “Valve opened” in the Manual calibration display. Check the Trend graph display to see that the measured value is stabilized. Then press the [Enter] key. The Manual calibration display shown in Figure 10.20 appears.

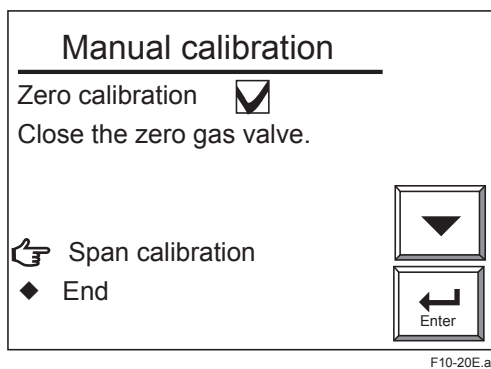

Figure 10.20 Zero-point Calibration Complete (in Manual Calibration)

- (3) Close the zero gas flow setting valve to stop the zero gas flow. If the valve has a lock nut, be sure to tighten the lock nut to prevent the any leakage of the zero gas into the sensor because the valve may become loose during measurement.

### 10.8.4 Operation After Calibration

No special operation of the instrument is needed after calibration. However, it is recommended that the pressure reducing valve for the zero gas cylinders be closed because calibration is not required so often.





---

# 11. Inspection and Maintenance

This chapter describes the inspection and maintenance procedures for the EXAxt ZR Explosion-proof Zirconia Oxygen Analyzer to maintain its measuring performance and normal operating conditions.

## WARNING

---

When checking the detector, carefully observe the following:

- The instrument modification or parts replacement by other than authorized representation of Yokogawa Electric Corporation is prohibited and will void ATEX flameproof Certification, Factory Mutual Explosion-proof approval and Canadian Standards Explosion-proof Certification.
  - Do NOT touch the probe if it has been in operation immediately just before being checked. (The sensor at the tip of the probe heats up to 750°C during operation. If you touch it, you will get burned.)
- 

## CAUTION

---

- Do not subject the probe to shock or cool it rapidly. The sensor is made of ceramic (zirconia). If the detector is dropped or bumped into something, the sensor may be damaged and no longer work.
  - Do not reuse a metal O-ring to seal the cell assembly. If you replace the cell or remove it from the probe for checking, be sure to replace the metal O-ring. Otherwise, the furnace gas may leak, and then the leaking corrosive gas will cause the built-in heater or thermocouple to go open circuit, or the detector may corrode.
  - Before opening or closing the terminal box, first remove dust, sand, or the like from the terminal box cover.
-

## 11.1 Inspection and Maintenance of the Detector

### 11.1.1 Cleaning the Calibration Gas Tube

The calibration gas, supplied through the calibration gas inlet of the terminal box into the detector, flows through the tube and comes out at the tip of the probe. The tube might become clogged with dust from the sample gas. If you become aware of clogging, such as when a higher pressure is required to achieve a specified flow rate ( $600 \pm 60$  ml/min), clean the calibration gas tube.

To clean the tube, follow these steps:

- (1) Remove the detector from the installation assembly. Remove the Flame Arrestor Assembly from Sensor Assembly (See Figure 11.2)
- (2) Following Subsection 11.1.2, later in this manual, remove the four bolts (and associated spring washers) that tighten the sensor assembly, and the pipe support as well as the U-shaped pipe.
- (3) Use a rod 2 to 2.5 mm in diameter to clean the calibration gas tube inside the probe. In doing this, keep air flowing from the calibration gas inlet at about 600 ml/min and insert the rod into the tube (3-mm inside diameter). However, be careful not to insert the rod deeper than 40 cm for a general-purpose detector, or 15 cm for a high temperature detector.
- (4) Clean the U-shaped pipe. The pipe can be rinsed with water. However, it should be dried out thoroughly before reassembly.
- (5) Restore all components you removed for cleaning. Follow Subsection 11.1.2 to restore all components in their original positions. Be sure to replace the O-ring(s) with new ones.

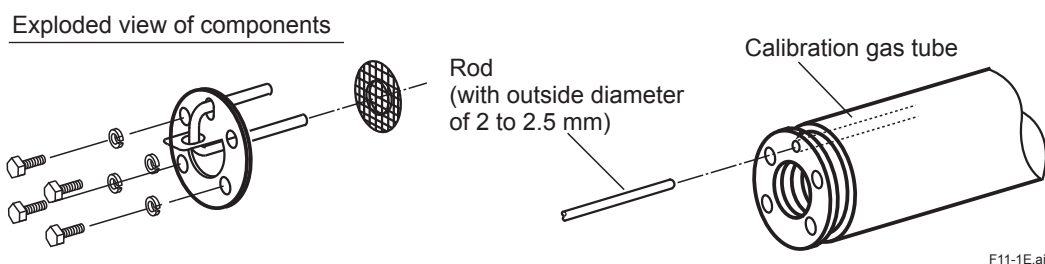

Figure 11.1 Cleaning the Calibration Gas Tube

### 11.1.2 Replacing the Sensor Assembly

The performance of the sensor (cell) deteriorates as its surface becomes soiled during operation. Therefore, you have to replace the sensor when its life expectancy expires, for example, when it can no longer satisfy a zero correction ratio of  $100 \pm 30\%$  or a span correction ratio of  $0 \pm 18\%$ . In addition, the sensor assembly is to be replaced if it becomes damaged and can no longer operate during measurement.

If the sensor becomes no longer operable (for example, due to breakage), investigate the cause and remedy the problem as much as possible to prevent recurrence.

**! CAUTION**

- If the sensor assembly is to be replaced, allow enough time for the detector to cool down from its high temperature. Otherwise, you may get burned.
- If the cell assembly is to be replaced, be sure to replace the metal O-ring and the contact together. Additionally, even in a case where the cell is not replaced, if the contact becomes deformed and cannot make complete contact with the cell, replace the contact.
- If there is any corroded or discolored area in the metal O-ring groove in which the contact is embedded, sand the groove with sandpaper or use a metal brush, and then sand further with a higher grade of sandpaper (no. 1500 or so), or use an appropriate metal brush to eliminate any sharp protrusions on the groove. The contact's resistance should be minimized.
- Use sensor assemblies manufactured in or after Sept. 2000: the serial number on the side of the sensor assembly should be 0J000 or later (for example: 0K123, 1AA01 etc)

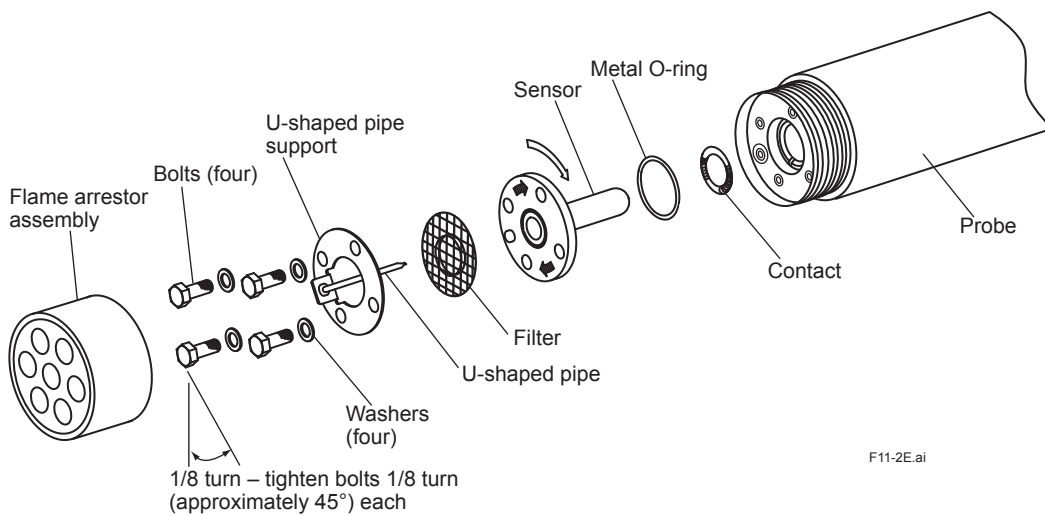

**Figure 11.2** Exploded View of Sensor Assembly

**! CAUTION**

Optional Inconel bolts have a high coefficient of expansion. If excess torque is applied while the bolts are being tightened, abnormal strain or bolt breakage may result. So, tighten the bolts following the instructions given above.

## 1. Identifying parts to be replaced

In order not to lose or damage disassembled parts, identify the parts to be replaced from among all the parts in the sensor assembly. Normally, replace the sensor, metal O-ring and contact together at the same time. If required, also replace the U-shaped pipe, bolts, filter and associated spring washers.

## 2. Removal procedures

- (1) Remove the flame arrestor assembly with a special wrench (part no. K9471UX).
- (2) Remove the four bolts and associated washers from the tip of the detector probe.
- (3) Remove the U-shaped pipe support together with the U-shaped pipe. Remove filter also.
- (4) Pull the sensor assembly toward you while turning it clockwise. Also, remove the metal O-ring between the assembly and the probe. Remove filter also.  
(When replacing the assembly, be careful not to scratch or dent the tip of the probe with which the metal O-ring comes in contact (the surface with which the sensor flange also comes in contact). Otherwise, the sample gas will not be sealed.)
- (5) Use tweezers to pull the contact out of the groove in the tip of the probe.
- (6) Clean the sensor assembly, especially the metal O-ring contact surface to remove any contaminants adhering to that part. If you can use any of the parts from among those removed, also clean them up to remove any contaminants adhering to them.  
(Once the metal O-ring has been used, it cannot be reused. So, be sure to replace it.)

## 3. Part assembly procedure

- (1) First, install the contact. Being careful not to cause irregularities in the pitch of the coil spirals (i.e., not to bend the coil out of shape), place it in the ringed groove properly so that it forms a solid contact.

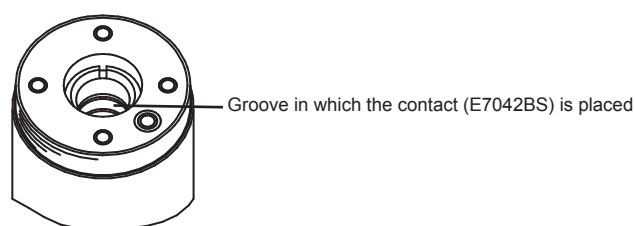

F11-3E.ai

**Figure 11.3** Installing the Contact

- (2) Next, make sure that the O-ring groove on the flange surface of the sensor is clean. Install the metal O-ring in that O-ring groove, and then insert the sensor in the probe while turning it clockwise. After inserting it until the metal O-ring comes in contact with the probe's O-ring contact surface, properly align the U-shaped-pipe insertion holes with the bolt openings.
- (3) Attach the U-shaped pipe to its support with filter, then fully insert the U-shaped pipe and its support into the probe.
- (4) Coat the threads of the four bolts with anti-seize grease and then screw them in along with the washers. First, tighten the four bolts uniformly by hand, and then use a torque wrench to tighten all areas of the metal O-ring uniformly, that is, to make sure the sensor flange is perfectly horizontal to the O-ring's working face in the probe.  
This is done by tightening first one bolt and then its opposing bolt each 1/8 turn, and then one of the other bolts followed by its opposing bolt, each also 1/8 turn. This continues in rotating fashion until they are all fully tightened with the torque wrench preset to approximately 5.9 N • m. If they are not uniformly tightened, the sensor or heater may be damaged.  
Replacement of the sensor assembly is now complete. Attach and fix the flame arrestor assembly. Install the detector and restart operation. Calibrate the instrument before making a measurement.

---

### 11.1.3 Replacement of the Heater Unit (Assembly)

This Subsection describes the replacement procedure for the heater unit.

The sensor or ceramic heater-furnace core internal structure is subject to fracturing, so do NOT subject it to strong vibrations or shock. Additionally, the heater unit reaches high temperatures and is subjected to high voltages. So, maintenance services should be performed after the power is off and the heater unit temperature has returned to normal room temperature.

For details, refer to IM11M12A01-21E “ Heater Assembly ”.

#### **NOTE**

---

If the heater strut assembly cannot be removed because a screw has fused to its thread, one of our service representatives can fix it.

---

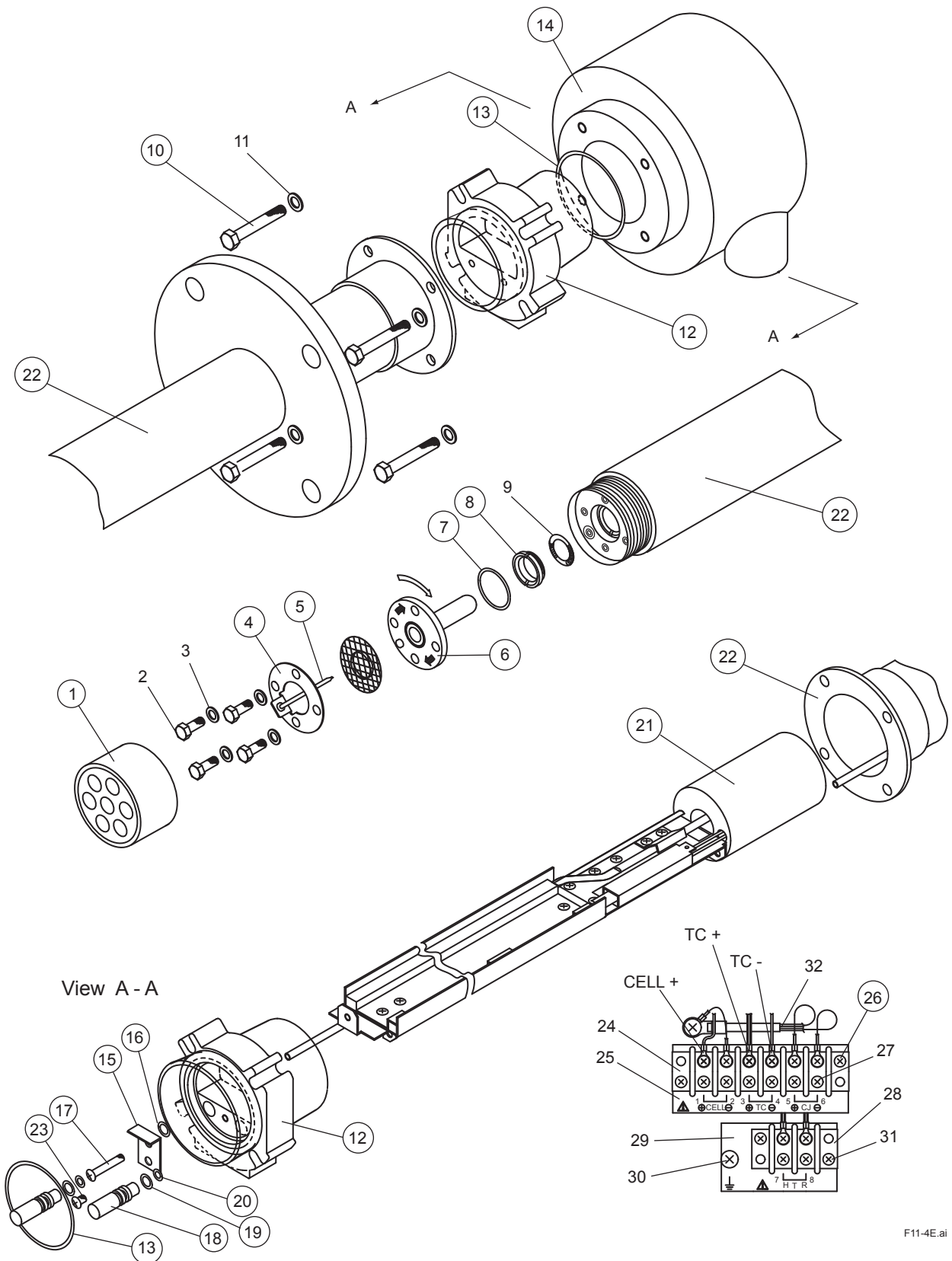

Figure 11.4 Exploded View of Detector

F11-4E.ai

### Replacement of heater strut assembly

Refer to Figure 11.4 as an aid in the following discussion.

Remove the U-shaped pipe support (4), the U-shaped pipe (5), the Filter and the Sensor (Cell) (6) according to Subsection 11.1.2 Replacing the Sensor Assembly. Open the terminal box (14) and remove the three terminal connections – CELL +, TC + and TC -. Before disconnect the HTR terminals, remove the terminal block screw (26). Keeping the other terminal remaining to be connected. Disconnect the two HTR connections. (These terminals have no polarity.)

Remove the four bolts (10) and terminal box (14) with care so that the already disconnected wire will not get caught in the terminal box.

Loosen Screw (17) until the plate (15) of heater strut assembly (21) can be removed. There's no need to remove O-ring (16) which prevents Screw (17) from coming out. Pull out connector (12).

Loosen and remove the screw for the heater assembly fixation (8) with a special wrench (part no. K9470BX or equivalent) and then remove the heater strut assembly (21) from the detector (22).

To reassemble the heater strut assembly, reverse the above procedure:

Insert the heater strut assembly (21) into the detector (22), while inserting the calibration pipe in the detector (22) into the heater section in the heater strut assembly (21) as well as in the bracket hole. Coat the screw for the heater assembly fixation (8) with grease (NEVER-SEEZ: G7067ZA) and tighten the screw for the heater assembly fixation (8) with a special wrench (part no. K9470BX or equivalent) with a tightening torque of 12N·m ±10 percent.

Next, to install the O-rings (20) on the calibration gas and reference gas pipes, disassemble the connector (12) in the following procedure:

First, remove the screw (23) and then remove the plate (15) and two caps (18). If the O-ring (20) remains in the hole, pull them out from the back. Pass the heater and thermocouple lead wire through the connector (12). Also, pass the calibration gas and reference gas pipes through the opening of the connector (12). If the O-ring (20) fails, replace it with a new one.

Push the two caps (18) into the associated opening of the connector (12). Insert the plate (15), aligning it with the groove of the cap (18), and tighten it with the screw (23). If you attempt to insert the calibration gas and reference gas pipes into the connector (12) without disassembling the connector (12), the O-ring may be damaged. Tighten Screw (17) to the plate (15) of heater strut assembly (21) until connector (12) can't move.

Reassemble in reverse order to the above disassembly procedure.

The two wires with ceramic insulators from the heater strut assembly are heater wires, and the single-core shielded wire is the cell signal + terminal; for the two-core shielded cable, the semi-translucent rubber-sheathed wire is the thermocouple + terminal, and the other wire is the – terminal. (If the wires are marked, match the markings with those on the terminal board).

When installing the sensor (cell) (6), replace the metal O-ring (7) with a new one.



### 11.1.4 Replacement of Flame Arrestor Assembly

If it takes longer for the analyzer to return to read the concentration of a sample gas after calibration, the flame arrestor may have become clogged. Inspect the flame arrestor and if necessary, clean or replace it.

Set the flame arrestor assembly ① in place using a special pin spanner (with a pin 4.5 mm in diameter: part no. K9471UX or equivalent). If a flame arrestor assembly that has already been replaced once is used again, apply grease (NEVER-SEEZ: G7067ZA) to the threads of the flame arrestor assembly.

If the flame arrestor assembly is clogged with dust, replace it with new one or wash it.

In case of the ATEX flameproof model (MS Code: ZR22S-A-...) or IECEx flameproof model (MS Code: ZR22S-D-...), the flame arrestor assembly ① is bonded to the detector ② with an ceramic adhesive. To remove the flame arrestor assembly ①, crack the hardened adhesive on the joint by tapping it with a flat blade screwdriver and a hammer or appropriate tools. After reattaching the flame arrestor assembly ①, apply a small amount of ceramic adhesive (part no. G7018ZA), with a diameter not exceeding 10 mm, to the joint part. Be careful not to allow the ceramic adhesive to enter between the female and the male screws. Before applying, stir the ceramic adhesive thoroughly. The ceramic adhesive should be stored in a cool, dark place and has a shelf life of 6 months from the date of shipment.

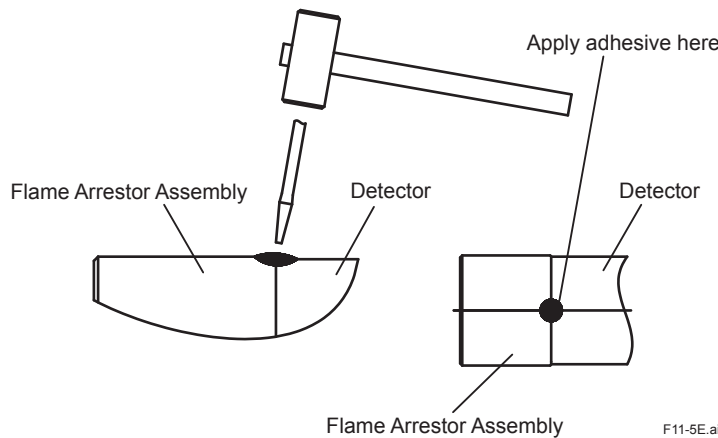

Figure 11.5 Removal of Flame Arrestor Assembly

### 11.1.5 Replacement of O-ring

The detector uses three different types of O-rings ⑬, ⑰, and ⑳, two O-rings of each type.

	Part No.	Description
⑦	K9470BJ	Metal O-ring
⑬	K9470ZS	O-ring with grease
⑰ ⑳	K9470ZP	Two pairs of O-rings with grease

### 11.1.6 Cleaning the High Temperature Probe Adapter

#### CAUTION

- Do NOT subject the probe of the High Temperature Probe Adapter (ZO21P) to shock. This probe uses silicon carbide (SiC) which may become damaged if it is subjected to a strong shock or thermal shock.

The high temperature detector is structured so that the gas to be measured is directed toward the detector with the high temperature probe adapter. Therefore, if the probe or the sample gas outlet clogs, a precise measurement is no longer possible because of no gas flow. If you use the high temperature detector, you have to inspect it periodically and, if any part of it is significantly clogged with dust, clean it.

Dust found sticking to the probe should be blown off. If any dust still remains after the blowing, clean it with a metal rod, etc., inserted. In addition, if dust is found on the auxiliary ejector assembly or needle valve (choke) at the sample gas outlet, remove these parts from the high temperature probe adapter and then clean them. To remove dust, blow air on them or rinse them with water.

### 11.1.7 Stopping and Re-starting Operation

#### <Stopping Operation>

When operation is stopped, take care of the followings so that the sensor of the detector cannot become unused.

#### CAUTION

When operating an instrument such as boiler or industrial furnace is stopped with the zirconia oxygen analyzer operation, moisture can condensate on the sensor portion and dusts may stick to it.

If operation is restarted in this condition, the sensor which is heated up to 750°C may become permanently contaminated. The dust can greatly degrade sensor performance. If a large amount of water is condensed, the sensor can be broken and never re-useful.

To prevent the above nonconformity, take the following action when stopping operation.

- (1) If possible, keep on supplying the power to converter and flowing reference gas to the sensor.  
If impossible to do the above, remove the detector.
- (2) If impossible to supply the power or remove the detector, at least keep on flowing air at 600 mL/min into the calibration gas pipe.

#### <Restarting Operation>

When restarting operation, be sure to flow air, for 5-10 minutes, at 600 mL/min into the calibration gas pipe before supplying the power to converter.

## 11.2 Inspection and Maintenance of the Converter

The converter does not require routine inspection and maintenance. If the converter does not work properly, in most cases it probably comes from problems or other causes.

A dirty touchpanel should be wiped off with a soft dry cloth.

### 11.2.1 Replacing Fuses

The converter incorporates a fuse, as indicated in Figure 11.6. If the fuse blows out, replace it in the following procedure.

#### NOTE

- If a replaced fuse blows out immediately, there may be a problem in the circuit. Go over the circuit completely to find out why the fuse has blown.
- This fuse is for protecting the main power supply circuit and does not provide overcurrent protection for the heater temperature control circuit. For overcurrent protection circuitry, refer to Subsection 12.1.2, Error 2: Heater Temperature Failure.

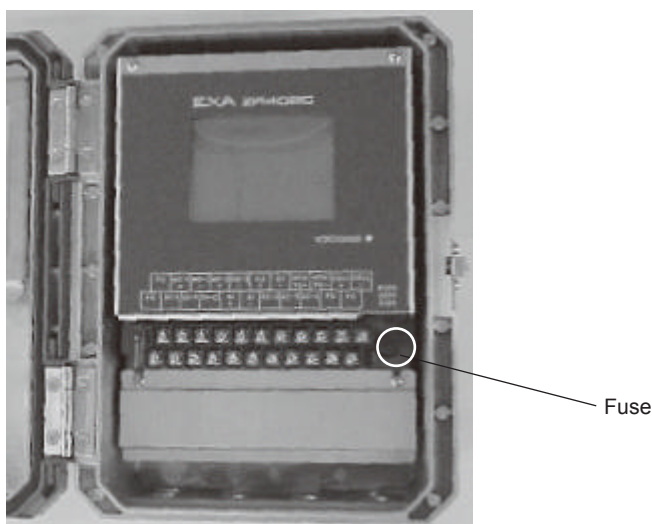

F11-6E.ai

Figure 11.6 Location of Fuse in the Converter

To replace the fuse, follow these steps:

- (1) Turn off the power to the converter for safe replacement.
- (2) Remove the fuse from its holder. With the appropriate flat-blade screwdriver that just fits the holder cap slot (Figure 11.7), turn the fuse holder cap 90° counterclockwise. By doing so, you can remove the fuse together with the cap.
- (3) Check the rating of the fuse and that it satisfies the following:
  - Maximum rated voltage: 250 V
  - Maximum rated current: 3.15 A
  - Type: Time-lag fuse
  - Standards: UL-, CSA- or VDE-approved
  - Part number: A1113EF

Place a new, properly rated fuse in the holder together with the cap, and push and turn the cap clockwise 90° with the screwdriver to complete installation of the fuse.

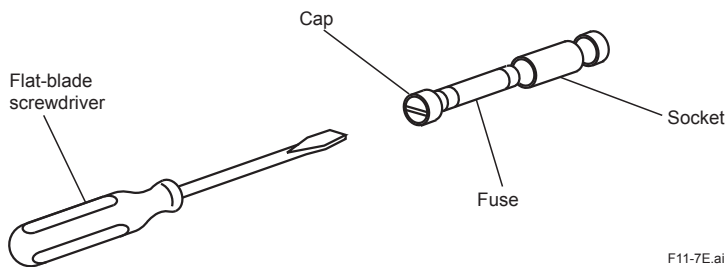

Figure 11.7 Removing the Fuse

### 11.2.2 Cleaning

Use a soft dry cloth to clean any part of the converter during inspection and maintenance.

### 11.2.3 Adjust LCD screen contrast

An LCD is built in the ZR402G converter. The contrast of this LCD is affected by its ambient temperature. For this reason, the LCD is shipped, after adjusting the contrast so as to become the most suitable in a room temperature(20-30°C). However, when display on the LCD is hard to see, adjust the LCD contrast by change the resistance of the variable resistor; its position is shown in Figure 11.8



Figure 11.8

### 11.3 Replacing Flowmeter in ZR40H Automatic Calibration Unit

- (1) Remove piping and wiring, and remove the ZR40H from the 2B pipe or wall mounting.
- (2) Remove four M6 bolts between brackets and remove piping extension
- (3) Remove bolts holding flowmeter, and replace it. A white back plate (to make the float easy to see) is attached. The end of the pin holding down the back plate must be on the bracket side.
- (4) Replace piping, and fix M6 bolts between brackets. \*1

\*1 : When disassembling and reassembling, mark original positions, and tighten an extra 5-10° when reassembling. After tightening, do a liquid leakage test.

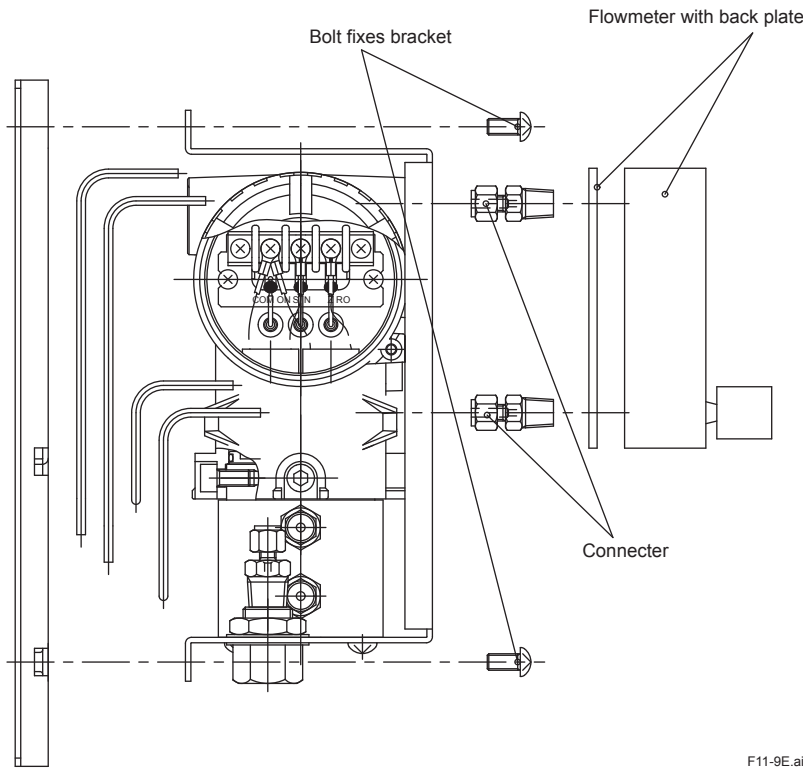

Figure 11.9 Flowmeter replacement

F11-9E.ai

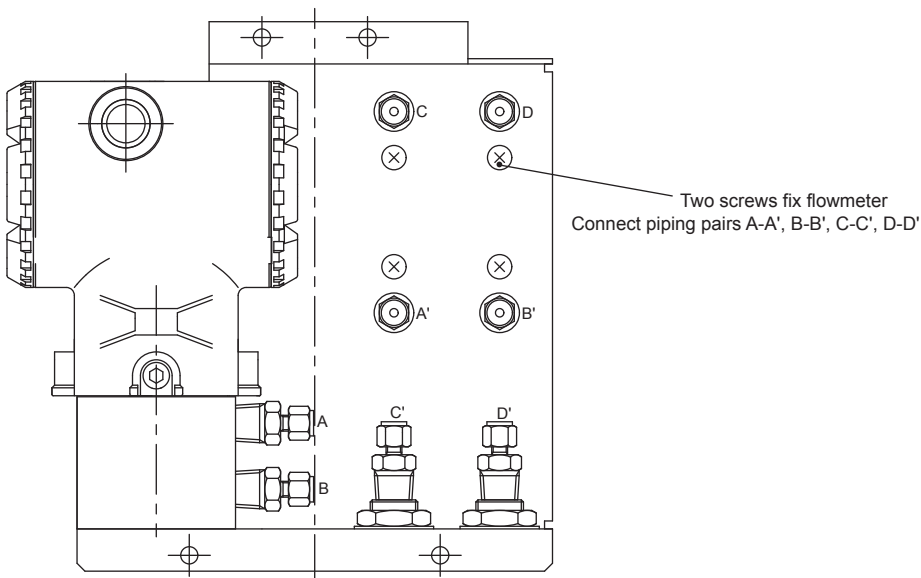

Figure 11.10 Fixing Flowmeter

F11-10E.ai

# 12. Troubleshooting

This chapter describes errors and alarms detected by the self-diagnostic function of the converter. It also explains inspections and remedies when other problems occur.

## 12.1 Displays and Remedies When Errors Occur

### 12.1.1 Error Types

An error occurs when an abnormality is detected in the detector or the converter, e.g., in the cell (sensor), detector heater, or internal circuits of the converter.  
If an error occurs, the converter performs the following:

- (1) Stops the supply of power to the heater in the detector to insure system safety.
- (2) Causes an error indication in the display to start blinking to notify of an error generation (Figure 12.1).
- (3) Sends a contact output if the error is set up for Contact output setting for that contact (refer to Section 8.4, Contact Output Setting).
- (4) Changes the analog output status to the one set in Output hold setting. (refer to Section 8.2, Output Hold Setting).

When the display shown in Figure 12.1 appears, pressing the error indication brings up a description of the error (Figure 12.2). The content of errors that are displayed include those shown in Table 12.1.

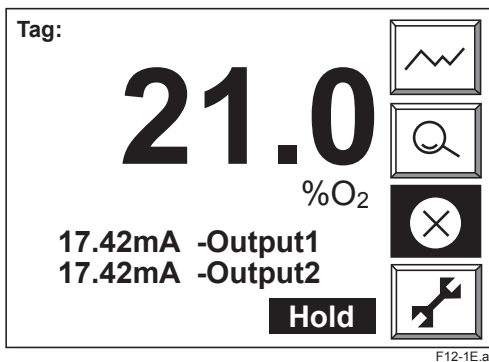

Figure 12.1

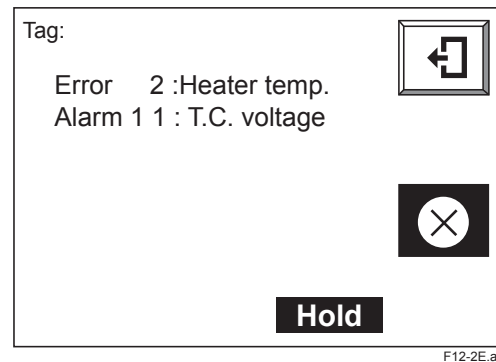

Figure 12.2

Table 12.1 Types of Errors and Reasons for Occurrence

Error No.	Error Type	Occurrence Conditions
Error 1	Cell voltage failure	The cell (sensor) voltage signal input to the converter falls below -50 mV.
Error 2	Heater temperature failure	The heater temperature does not rise during warm-up, or it falls below 730 °C or exceeds 780°C after warm-up is completed. Or this occurs if the TC+, TC- thermocouple terminals wired to detector with reverse (wrong) polarity.
Error 3	A/D converter failure	The A/D converter fails in the internal electrical circuit in the converter.
Error 4	Memory failure	Data properly are not written into memory in the internal electrical circuit in the converter.

### 12.1.2 Remedies When an Error Occurs

#### Error 1: Cell Voltage Failure

Error 1 occurs when the cell (sensor) voltage input to the converter falls below -50 mV (corresponding to about 200 vol% O<sub>2</sub>). The following are considered to be the causes for the cell voltage falling below -50 mV:

- (1) Poor contact in terminal connections between the converter and detector.
- (2) Breakage in wiring cable between the converter and the detector.
- (3) Damage or deterioration of the sensor assembly.
- (4) Continuity failure between the sensor assembly electrode and the contact.
- (5) Wiring failure inside the detector.
- (6) Abnormality in electrical circuits inside the converter.

#### <Locating cause of failure, and countermeasures>

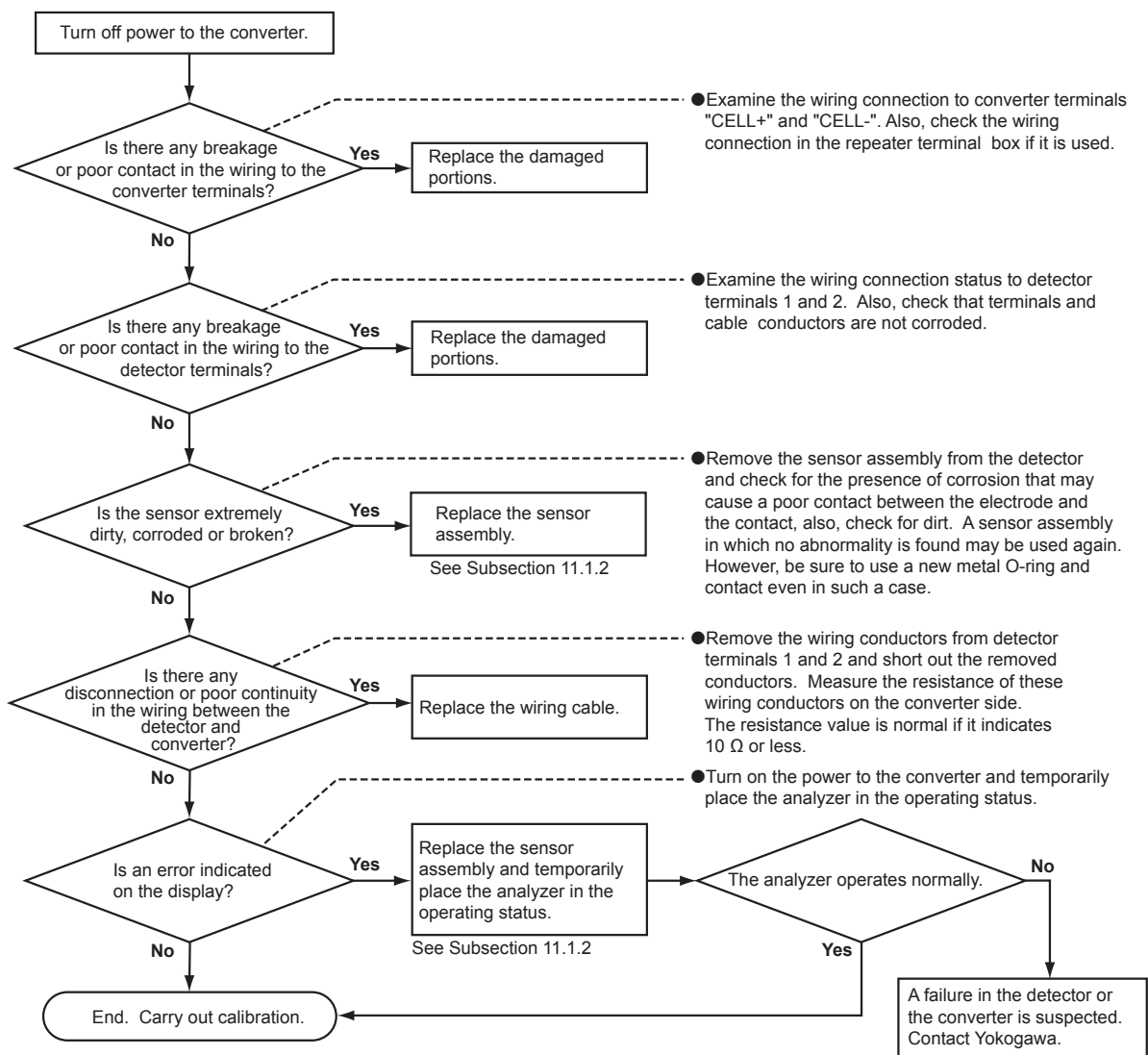

F12E.ai

## Error 2: Heater Temperature Failure

This error occurs if the detector heater temperature does not rise during warm-up, or if the temperature falls below 730°C, or exceeds 780°C after warm-up is completed. In addition, when Error 2 occurs, Alarm 10 (cold junction temperature alarm) or Alarm 11 (thermocouple voltage alarm) may be generated at the same time. Be sure to press the error indication to get the error description and confirm whether or not these alarms are being generated simultaneously.

If Alarm 10 is generated simultaneously, a failure in the cold junction system on the detector terminal block is suspected. In this case, follow the procedure according to troubleshooting for Alarm 10 in Subsection 12.2.2.

If Alarm 11 is generated simultaneously, a failure in the thermocouple system located in the detector heater is suspected. In this case, follow the procedure according to troubleshooting for Alarm 11 in Subsection 12.2.2.

If this failure occurs immediately after the power is supplied, the polarity at thermocouple input connection (TC+, TC-) on the converter may be reversed. Check the connection from the detector.

Causes considered for cases where Error 2 occurs independently are shown below.

- (1) Faulty heater in the detector (heater wire breakage).
- (2) Faulty thermocouple in the detector.
- (3) Faulty cold junction sensor located at the detector terminal block.
- (4) Failure in electrical circuits inside the converter.
- (5) Heater temperature control overcurrent limiting triggered.
- (6) TC+ ,TC- thermocouple terminals wired to detector with reverse (wrong) polarity.

Overcurrent protection is triggered if there are problems in the heater wiring. When the protective circuit is triggered, the internal fuse blows and the heater is disconnected, resulting in Error 2 (heater temperature failure).

### <Locating cause of failure, and countermeasures>

- (1) Turn off power to the converter.
- (2) Remove the cable from terminals 7 and 8 of the detector and measure the resistance value between these terminals. The heater unit is normal if the resistance is lower than about 90 Ω. If the resistance value is higher, failure of the heater unit is suspected. In this case, replace the heater unit (refer to Subsection 11.1.3, Replacement of the Heater Unit (Assembly)). In addition, check that the wiring resistance between the converter and detector is 10 Ω or less.
- (3) Ensure that TC+ terminal (terminal 3 in detector) is connected to converter TC+ terminal, and TC- terminal (terminal 4) is connected to converter TC- terminal.
- (4) Remove the wiring from terminals 3 and 4 of the detector and measure the resistance value between these terminals. The thermocouple is considered normal if the resistance value is 5 Ω or less. If the value is higher than 5 Ω, it may indicate that the thermocouple wire has broken or is about to break. In this case, replace the heater unit (refer to Subsection 11.1.3, Replacement of the Heater Unit (Assembly)). Also, check that the wiring resistance between the converter and detector is 10 Ω or less.
- (5) Even if items (2) to (4) are normal, the heater overcurrent protection fuse may have blown. Check for wiring problems such as the following:
  - 1) Heater terminals shorted.
  - 2) Heater terminal(s) shorted to ground.
  - 3) Heater terminals shorted to power supply.

If the internal fuse blows, this cannot be replaced by the user. Contact your Yokogawa service representative.



---

**NOTE**

Measure the thermocouple resistance value after the temperature difference between the detector tip and the ambient atmosphere has decreased to 50°C or less. If the thermocouple voltage is large, accurate measurement cannot be achieved.

---

**Error 3: A/D Converter Failure/Error 4: Writing-to-memory Failure**

- A/D Converter Failure

It is suspected that a failure has occurred in the A/D converter mounted in the electrical circuits inside the converter.

- Writing-to-memory Failure

It is suspected that a failure has occurred in an operation writing to the memory (EEPROM) mounted in the electrical circuits inside the converter.

**<Locating cause of failure, and countermeasures>**

Turn off the power to the converter once and then restart the converter. If the converter operates normally after restarting, an error might have occurred due to a temporary drop in the voltage (falling below 85 V, the least amount of voltage required to operate the converter) or a malfunction of the electrical circuits affected by noise. Check whether or not there is a failure in the power supply system or whether the converter and detector are securely grounded.

If the error occurs again after restarting, a failure in the electrical circuits is suspected. Consult the service personnel at Yokogawa Electric Corporation.

# 12.2 Displays and Remedies When Alarms are Generated

## 12.2.1 Alarm Types

When an alarm is generated, the alarm indication blinks in the display to notify of the alarm (Figure 12.3). Pressing the alarm indication displays a description of the alarm. Alarms include those shown in Table 12.2.

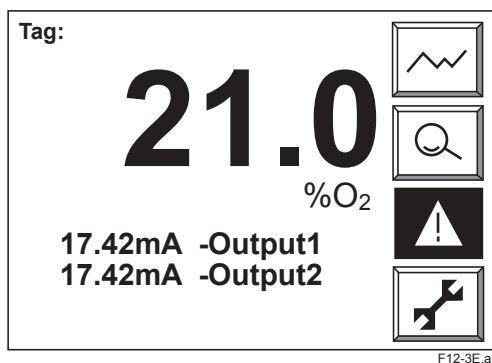

Figure 12.3

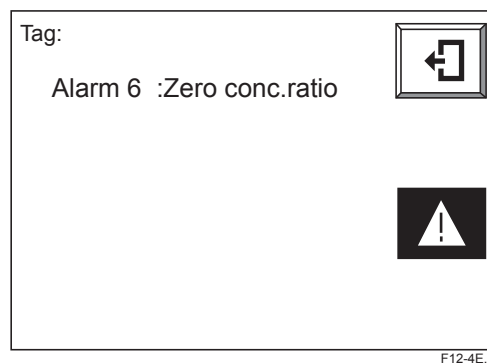

Figure 12.4

Table 12.2 Types of Alarms and Reasons for Occurrence

Alarm No.	Alarm Type	Occurrence Conditions
Alarm 1	Oxygen concentration alarm	Measured oxygen concentration value exceeds or falls below the preset alarm limits. (refer to Section 8.3, Oxygen Concentration Alarms Setting).
Alarm 6	Zero calibration coefficient (correction ratio) alarm	In automatic or semi-automatic calibration, zero correction ratio is outside the range of 100±30%. (refer to Subsection 9.1.3, Compensation).
Alarm 7	Span calibration coefficient (correction ratio) alarm	Span correction ratio is outside the range of 0±18% (refer to Subsection 9.1.3, Compensation).
Alarm 8	EMF stabilization time-up alarm	In automatic or semi-automatic calibration, cell voltage does not stabilize after the calibration time is up.
Alarm 10	Cold junction temperature alarm	Temperature of the cold junction placed in the detector terminal box falls below -25°C or exceeds 155°C.
Alarm 11	Thermocouple voltage alarm	Generated when thermocouple voltage exceeds 42.1 mV (about 1020°C) or falls below -5 mV (about -170°C).
Alarm 13	Battery low alarm	Internal battery needs replacement.

If an alarm is generated, actions such as turning off the heater power are not carried out. The alarm is cancelled when the cause of the alarm is eliminated. However, Alarm 10 and/or Alarm 11 may be generated concurrently with Error 2 (heater temperature failure). In this case, the operation when the error occurs has priority.

If the power to the converter is turned off after an alarm is generated and the converter is restarted before the cause of the alarm has been eliminated, the alarm will be generated again. However, Alarms 6, 7, and 8 (alarms related to calibration) are not generated unless calibration is executed.

## 12.2.2 Remedies When Alarms are Generated

### Alarm 1: Oxygen Concentration Alarm

This alarm is generated when a measured value exceeds an alarm set point or falls below it. For details on the oxygen concentration alarm, see Section 8.3, Oxygen Concentration Alarms Setting, in the chapter on operation.

### Alarm 6: Zero Calibration Coefficient (Correction Ratio) Alarm

In automatic or semi-automatic calibration, this alarm is generated when the zero correction ratio is out of the range of  $100\pm 30\%$  (refer to Subsection 9.1.3, Compensation).

The following are possible causes of this alarm.

- (1) The zero gas oxygen concentration does not agree with the value of the zero gas concentration set in Calibration setup. Otherwise, the span gas is used as the zero gas.
- (2) The flow rate of zero gas is out of the specified flow ( $600\pm 60$  ml/min).
- (3) The sensor assembly is damaged and so cell voltage is not normal.

#### <Locating cause of alarm, and countermeasures>

- (1) Check that the following have been set up correctly. If not, correct them. Then, recalibrate.
  - a. Check the preset zero gas concentration in the Calibration setup display. The displayed concentration value has agreed with the concentration of the zero gas actually used.
  - b. The piping for calibration gases has been constructed so that the zero gas does not leak.
- (2) If the alarm is not generated during the recalibration, improper calibration conditions are considered as the cause of the alarm generated in the previous calibration. In this case, no particular restoration is necessary.
- (3) If the alarm is generated again during the recalibration, deterioration of or damage to the sensor assembly is considered as the cause of the alarm. It is necessary to replace the sensor (cell) with a new one. Before replacement, carry out the following. Check the cell voltages when the zero gas and span gas are introduced.
  - a. Display the Detailed-data display by pressing the [Detailed-data] key in the Basic panel display.
  - b. When the [▼] key is pressed once, the cell voltage should be indicated on the top line (Figure 12.5).
  - c. Check whether or not the displayed cell voltage is very different from the theoretical value at the oxygen concentration of the relevant gas. See Table 12.3 for the theoretical cell voltages. Although the tolerance to the theoretical value cannot be generally specified, a reasonable one may be approximately  $\pm 10$  mV.

**Table 12.3** Oxygen Concentration and Cell Voltage

Oxygen concentration (vol%O <sub>2</sub> )	Cell voltage(mV)
1%	67.1
21%	0

- (4) Check whether the deterioration of or damage to the sensor assembly that caused the alarm has occurred suddenly during the current calibration in the following procedure:
  - a. Call up the Detailed-data Display.
  - b. Use the [Page Scroll] key to check Calibration data (Figure 12.6). The span and zero correction ratios of the last ten calibration can be checked here. By checking these data, whether the sensor deterioration has occurred suddenly or gradually can be determined.

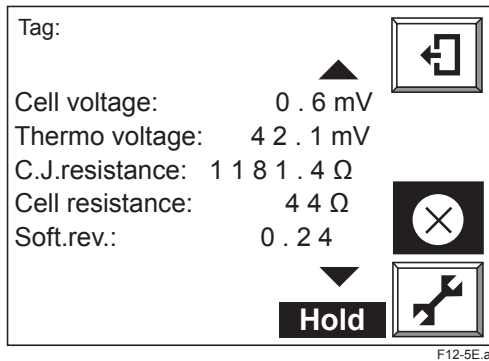

Figure 12.5 Detailed-data Display

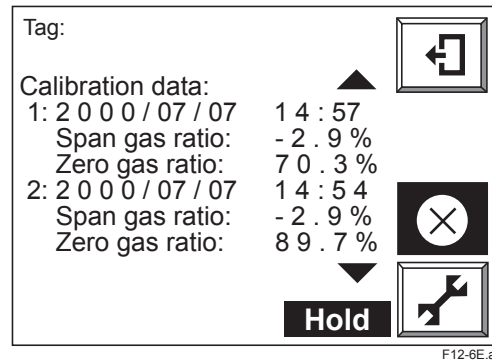

Figure 12.6 Calibration History

- (5) If the sensor assembly has deteriorated suddenly, the check valve that prevents moisture in the furnace from entering into the calibration pipes may have malfunctioned. If the furnace gas flows into calibration lines, the gas is cooled and thus condensation develops and accumulates in the pipe. During calibration the condensate is carried with the calibration gas and blow onto the sensor assembly, whereby the cell is cooled quickly. This results in the failed sensor assembly.
- (6) If the sensor assembly has deteriorated gradually, check the condition of the sensor assembly following the procedure below.
  - a. Use the [Page Scroll] key to check Cell Resistance. It should be 200 Ω or less if the cell (sensor) is new. On the other hand, if the cell (sensor) is approaching the end of its service life, it will be 3 to 10 kΩ.
  - b. Use the [Page Scroll] key to check Cell robustness. It should say “life > 1 year” if the cell (sensor) is in good condition.

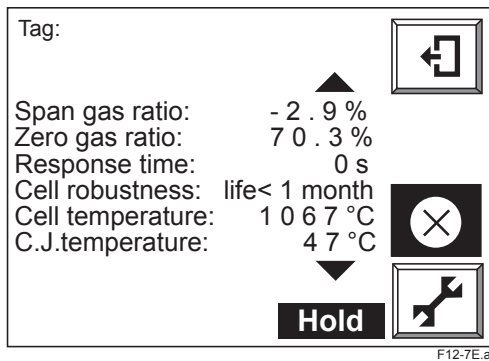

Figure 12.7

**Alarm 7: Span Calibration Coefficient (Correction Ratio) Alarm**

In automatic or semi-automatic calibration, this alarm is generated when the span correction ratio is out of the range of  $0\pm 18\%$  (refer to Subsection 9.1.3, Compensation).

The following are suspected as the cause:

- (1) The oxygen concentration of the span gas does not agree with the value of the span gas set in Calibration setup.
- (2) The flow of the span gas is out of the specified flow value ( $600\pm 60$  ml/min).
- (3) The sensor assembly is damaged and the cell voltage is abnormal.

**<Locating cause of alarm, and countermeasures>**

- (1) Confirm the following and carry out calibration again: If the items are not within their proper states, correct them.
  - a. If the display "Span gas conc" is selected in Calibration setup, the set point should agree with the concentration of span gas actually used.
  - b. The calibration gas tubing should be constructed so that the span gas does not leak.
- (2) If no alarm is generated as a result of carrying out re-calibration, it is suspected that improper calibration conditions were the cause of the alarm in the preceding calibration. In this case, no specific restoration is necessary.
- (3) If an alarm is generated again as a result of carrying out re-calibration, deterioration of or damage to the sensor assembly is suspected as the cause of the alarm. Replacement of the sensor (cell) with a new one is necessary. However, before replacement, carry out the procedure described in step (3) and later of <Location cause of alarm and countermeasures> in Subsection 12.2.2, Alarm 6: Zero Calibration Coefficient (Correction Ratio) Alarm.

**Alarm 8: EMF Stabilization Time-up Alarm**

This alarm is generated if the sensor (cell) voltage has not stabilized even after the calibration time is up for the reason that the calibration gas (zero gas or span gas) has not filled the sensor assembly of the detector.

The following are suspected as the cause:

- (1) The flow of the calibration gas is less than normal (a specified flow of  $600\pm 60$  ml/min).
- (2) The length or thickness of the calibration gas tubing has been changed (lengthened or thickened).
- (3) The sample gas flows toward the tip of the probe.
- (4) The sensor (cell) response has deteriorated.

**<Locating cause of alarm, and countermeasures>**

- (1) Carry out calibration by passing the calibration gas at the specified flow ( $600\pm 60$  ml/min) after checking that there is no leakage in the tubing.
- (2) If calibration is carried out normally, perform a steady operation without changing the conditions. If the error occurs again, check whether or not the reason is applicable to the following and then replace the sensor assembly.
  - A lot of dust and the like may be sticking to the tip of the detector probe. If dust is found, clean the probe (see Subsection 11.1.1).In addition, if an error occurs in calibration even after the sensor assembly is replaced, the influence of sample gas flow may be suspected. Do not let the sample gas flow toward the tip of the detector probe, for example, by changing the mounting position of the detector.

**Alarm 10: Cold Junction Temperature Alarm**

This alarm is generated when the temperature of the cold junction located at the terminal block of the detector falls below  $-25^{\circ}\text{C}$  or exceeds  $155^{\circ}\text{C}$ . Check the following:

Display "C.J.temperature" in the Detailed-data display. If "C.J.temperature" is indicated as  $200^{\circ}\text{C}$  or  $-50^{\circ}\text{C}$ , the following can be considered.

- (1) Breakage of the cold junction signal wires between the converter and the detector occurred, or the cable is not securely connected to the connecting terminals.
- (2) The positive and negative poles of the cold junction signal wiring are shorted out in the wiring extension or at the connection terminals.
- (3) A failure of the cold junction temperature sensor located at the detector terminal block occurred.
- (4) A failure of the electrical circuits inside the converter occurred.

If "C.J.temperature" exceeds  $150^{\circ}\text{C}$  or falls below  $-20^{\circ}\text{C}$ , the following can be considered.

- (1) The temperature of the detector terminal block is out of the operating temperature range ( $-20$  to  $150^{\circ}\text{C}$ ).
- (2) A failure of the cold junction temperature sensor located at the detector terminal block occurred.
- (3) A failure of the electrical circuits inside the converter occurred.

**<Locating cause of alarm and countermeasures>**

Before proceeding to the following troubleshooting procedure, examine whether or not the temperature of the detector terminal block is out of the operating temperature range.

The operating temperature range varies with the type of detector. If the detector terminal block is out of its operating temperature range, take the measure to lower the temperature, such as situating it so that it is not subjected to radiant heat.

**The case where the Model ZR22 Detector is used:**

- (1) Stop the power to the converter.
- (2) Remove the wiring from terminals 5 and 6 of the detector and measure the resistance between these terminals. If the resistance value is out of the range of 1 to  $1.6\text{ k}\Omega$ , the cold junction temperature sensor is considered to be faulty. Replace that temperature sensor with a new one.
- (3) If the resistance value is within the above range, the cold junction temperature sensor seems to be normal. Check whether or not the cable is broken or shorted out, and whether the cable is securely connected to the terminals. Also, check that the resistance of the wiring between the converter and detector is  $10\ \Omega$  or less.
- (4) If there is no failure in the wiring, the electrical circuits inside the converter may possibly fail. Contact the service personnel at Yokogawa Electric Corporation.

**Alarm 11: Thermocouple Voltage Alarm**

This alarm is generated when the e.m.f. (voltage) of the thermocouple falls below -5 mV (about -170°C) or exceeds 42.1 mV (about 1020°C). Whenever Alarm 11 is generated, Error 2 (heater temperature failure) occurs.

The following are suspected as the cause:

- (1) Breakage of the heater thermocouple signal wire between the converter and the detector occurred, or the cable is not securely connected to the connecting terminals.
- (2) The positive and negative poles of the heater thermocouple signal wiring are shorted out in the wiring extension or at the connection terminals.
- (3) A failure of the thermocouple at the detector heater assembly occurred.
- (4) A failure of the electrical circuits inside the converter occurred.

**<Locating cause of alarm, and countermeasures>**

- (1) Stop the power to the converter.
- (2) Remove the wiring from terminals 3 and 4 of the detector and measure the resistance between these terminals. If the resistance value is 5  $\Omega$  or less, the thermocouple seems to be normal. If it is higher than 5  $\Omega$ , it may indicate the possibility that the thermocouple has broken or is about to break. In this case, replace the heater assembly (refer to Subsection 11.1.3, Replacement of the Heater Unit (Assembly)).

 **CAUTION**

Measure the thermocouple resistance value after the difference between the detector tip temperature and ambient temperature falls to 50°C or less. If the thermocouple voltage is large, accurate measurement cannot be achieved.

- (3) If the thermocouple is normal, check whether or not the wiring cable is broken or shorted out, and also whether the wiring cable is securely connected to the terminals. Also check that the wiring resistance between the converter and the detector is 10  $\Omega$  or less.
- (4) If there is no failure in the wiring, the electrical circuits inside the converter may possibly fail. Contact the service personnel at Yokogawa.

**Alarm 13: Battery Low Alarm**

An internal battery is used as backup for the clock. After this alarm occurs, removing power from the instrument may cause the clock to stop but should not affect stored parameters. The internal clock is used for blow back scheduling; if you use this then after a battery alarm occurs (until the battery is replaced) be sure to check/correct the date and time every time you turn on the power.

**<Corrective action>**

When the battery low alarm occurs, remember that the battery cannot be replaced by the user. Contact your Yokogawa service representative.

**NOTE**

Battery life varies with environmental conditions.

- \* If power is applied to the instrument continuously, then the battery should not run down, and life is typically about ten years. However the battery will be used during the time interval between shipment from the factory and installation.
- \* If power is not applied to the instrument, at normal room temperatures of 20 to 25°C then battery life is typically 5 years, and outside this range but within the range -30 to +70°C then battery life is typically 1 year.

## 12.3 Countermeasures When Measured Value Shows Error

The causes that the measured value shows an abnormal value is not always due to instrument failures. There are rather many cases where the causes are those that sample gas itself is in abnormal state or external causes exist, which disturb the instrument operation. In this section, causes of and measures against the cases where measured values show the following phenomena will be described.

- (1) The measured value is higher than the true value.
- (2) The measured value is lower than the true value.
- (3) The measured value sometimes shows abnormal values.

### 12.3.1 Measured Value Higher Than True Value

#### <Causes and Countermeasures>

- (1) The sample gas pressure becomes higher.

The measured oxygen concentration value  $X$  (vol%O<sub>2</sub>) is expressed as shown below, when the sample gas pressure is higher than that in calibration by  $\Delta p$  (kPa).

$$X=Y [ 1+ (\Delta p/101.30) ]$$

where  $Y$ : Measured oxygen concentration value at the same pressure as in calibration (vol%O<sub>2</sub>).

Where an increment of the measured value by pressure change cannot be neglected, measures must be taken.

Investigate the following points to perform improvement available in each process.

- Is improvement in facility's aspect available so that pressure change does not occur?
- Is performing calibration available under the average sample gas pressure (internal pressure of a furnace)?

- (2) Moisture content in a reference gas changes (increases) greatly.

If air at the detector installation site is used for the reference gas, large change of moisture in the air may cause an error in measured oxygen concentration value (vol%O<sub>2</sub>).

When this error is not ignored, use a gas in which moisture content is constant such as instrument air in almost dry condition as a reference gas.

In addition, change of moisture content in exhaust gas after combustion is also considered as a cause of error. However, normally this error is negligible.

- (3) Calibration gas (span gas) is mixing into the detector due to leakage.

If the span gas is mixing into the detector due to leakage as a result of failure of the valve provided in the calibration gas tubing system, the measured value shows a value a little higher than normal.

Check valves (needle valves, check valves, solenoid valves for automatic calibration, etc.) in the calibration gas tubing system for leakage. For manual valves, check them after confirming that they are in fully closed states. In addition, check the tubing joints for leakage.

- (4) The reference gas is mixing into the sample gas and vice versa.

Since the difference between oxygen partial pressures on the sensor anode and cathode sides becomes smaller, the measured value shows a higher value.

An error which does not appear as the Error 1 may occur in the sensor. Sample gas and/or the reference gas may be leaking. Visually inspect the sensor. If any crack is found, replace the sensor assembly with a new one.

#### NOTE

Data such as cell robustness displayed in the Detailed-data display should also be used for deciding sensor quality as references.



### 12.3.2 Measured Value Lower Than True Value

#### <Causes and Countermeasures>

- (1) The sample gas pressure becomes lower.  
Where an increment of the measured value due to pressure change cannot be neglected, take measures referring to Subsection 12.3.1 (1).
- (2) Moisture content in a reference gas changes (decreases) greatly.  
If air at the detector installation site is used for the reference gas, large change of moisture content in the air may cause an error in measured oxygen concentration value (vol%O<sub>2</sub>).  
When this error is not ignored, use a gas in which moisture content is constant such as instrument air in almost dry condition as a reference gas.  
In addition, change of moisture content in exhaust gas after combustion is also considered as a cause of error. However, normally this error is negligible.
- (3) Calibration gas (zero gas) is mixed into the detector due to leakage.  
If the zero gas is mixed into the detector due to leakage as a result of failure of the valve provided in the calibration gas tubing system, the measured value shows a value a little lower than normal.  
Check valves (needle valves, check valves, solenoid valves for automatic calibration, etc.) in the calibration gas tubing system for leakage. For manual valves, check them after confirming that they are in a fully closed situation.
- (4) Combustible components exist in the sample gas. If combustible components exist in the sample gas, they burn in the sensor and thus oxygen concentration decreases.  
Check that there are no combustible components.
- (5) Temperature of the detector cell reaches 750°C or more.

### 12.3.3 Measurements Sometimes Show Abnormal Values

#### <Cause and Countermeasures>

- (1) Noise may be mixing in with the converter from the detector output wiring.  
Check whether the converter and detector are securely grounded.  
Check whether or not the signal wiring is laid along other power cords.
- (2) The converter may be affected by noise from the power supply.  
Check whether or not the converter power is supplied from the same outlet, switch, or breaker as other power machines and equipment.
- (3) Poor wiring contact.  
If there is poor contact in the wiring, the sensor voltage or thermocouple e.m.f. (voltage) may vary due to vibration or other factors.  
Check whether or not there are loose points in the wiring connections or loose crimping (caulking) at the crimp-on terminal lugs.
- (4) There may be a crack in the sensor or leakage at the sensor-mounting portion.  
If the indication of concentration varies in synchronization with the pressure change in the furnace, check whether or not there is a crack in the sensor or whether the sensor flange is sticking tightly to the probe-attaching face with the metal O-ring squeezed.
- (5) There may be leakage in the calibration gas tubing.  
In the case of a negative furnace inner pressure, if the indication of concentration varies with the pressure change in the furnace, check whether or not there is leakage in the calibration gas tubing.

# Customer Maintenance Parts List

Model ZR22S  
Zirconia Oxygen Analyzer, Detector  
(Separate type Explosion-proof)

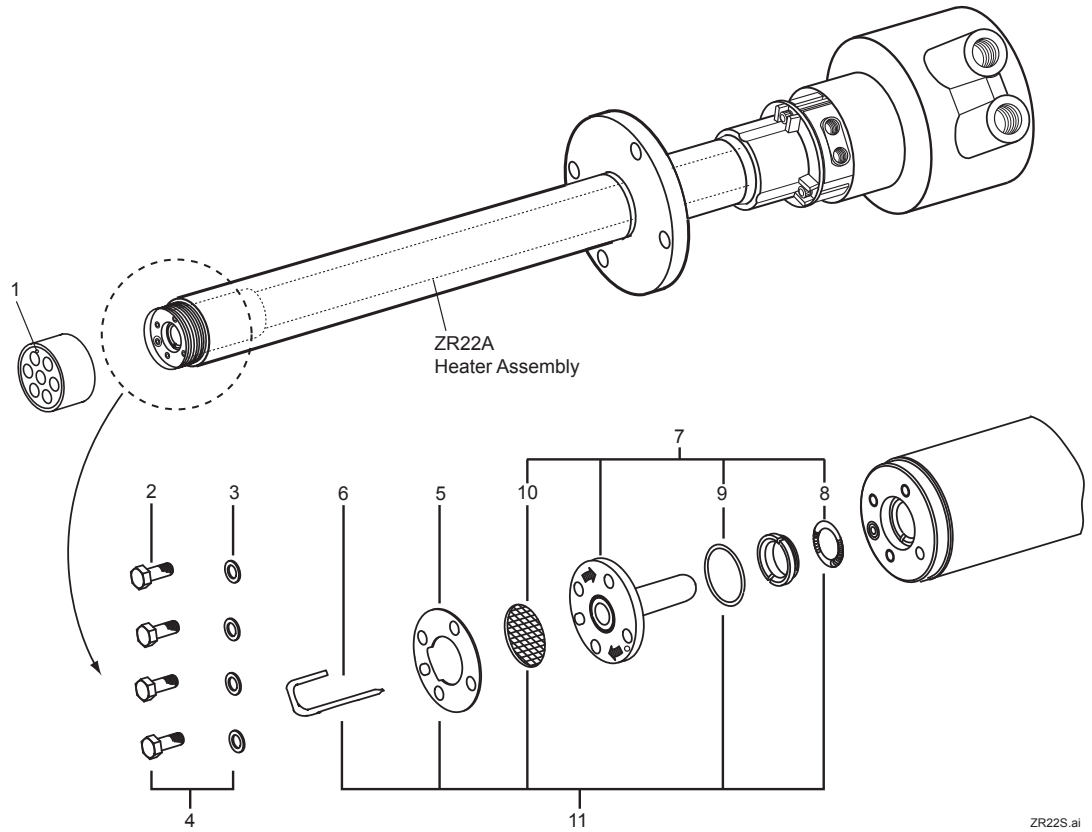

ZR22S.ai

Item	Part No.	Qty	Description
1	K9477EA	1	Flame Arrestor
2	---	4	Bolt
	G7109YC		(M5x12, SUS316 stainless steel)
	K9470BK		(M5x12, inconel) for Option code "/C"
3	E7042DW	4	Washer (SUS316 stainless steel)
4	---	1	Bolts and Washers
	K9470ZF		G7109YC x 4 + E7042DW x 4
	K9470ZG		K9470BK x 4 + E7042DW x 4 for Option code "/C"
5	E7042BR	1	Plate
6	K9470BM	1	Pipe
7	K9473AN	1	Pipe for Option code "/C"
	---	1	Cell Assembly
	E7042UD		only for Japan
	ZR01A01		for other than Japan
8	E7042BS	1	Contact
9	K9470BJ	1	Metal O-ring
10	E7042AY	1	Filter
11	---	1	Calibration Tube Assembly
	K9470ZK		Cal. Gas Tube Assembly
	K9470ZL		Cal. Gas Tube Assembly for Option code "/C"



# Customer Maintenance Parts List

Model ZR402G  
Zirconia Oxygen Analyzer/High Temperature  
Humidity Analyzer, Converter

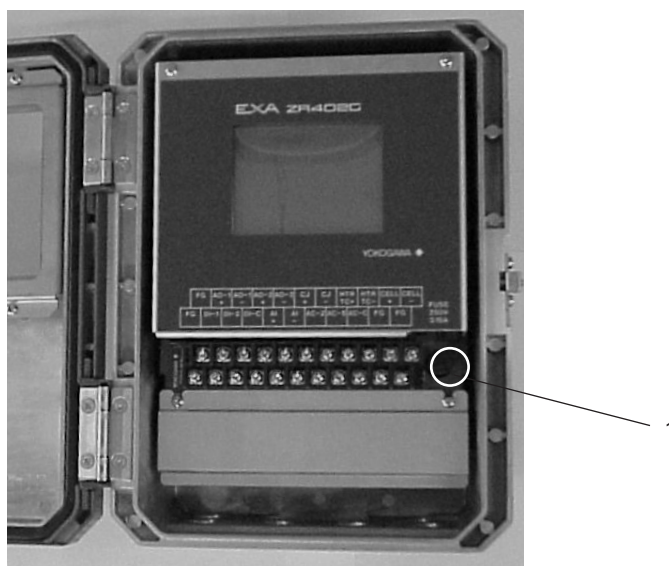

## Hood for ZR402G

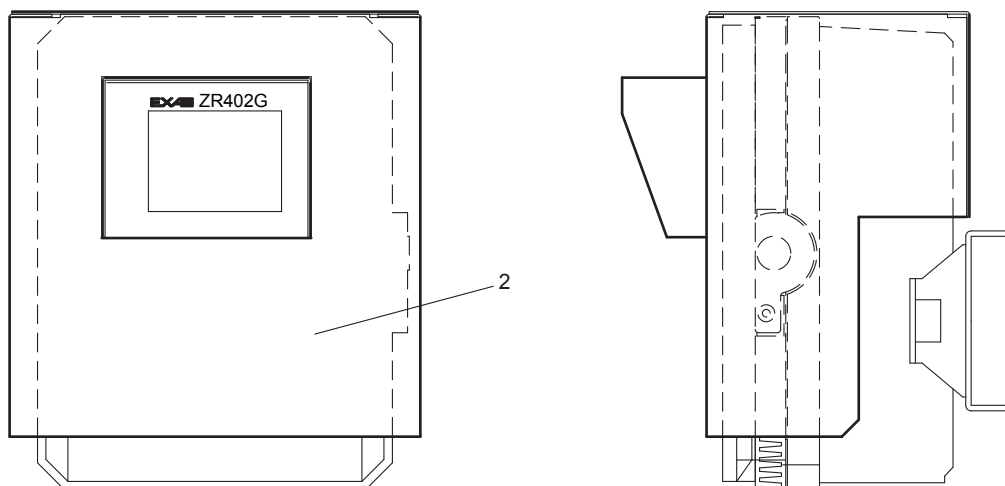

Item	Part No.	Qty	Description
1	A1113EF	1	Fuse (3.15A)
2	K9471UF	1	Hood







# Customer Maintenance Parts List

Model ZO21P-H  
Zirconia Oxygen Analyzer  
High Temperature Probe Adaptor

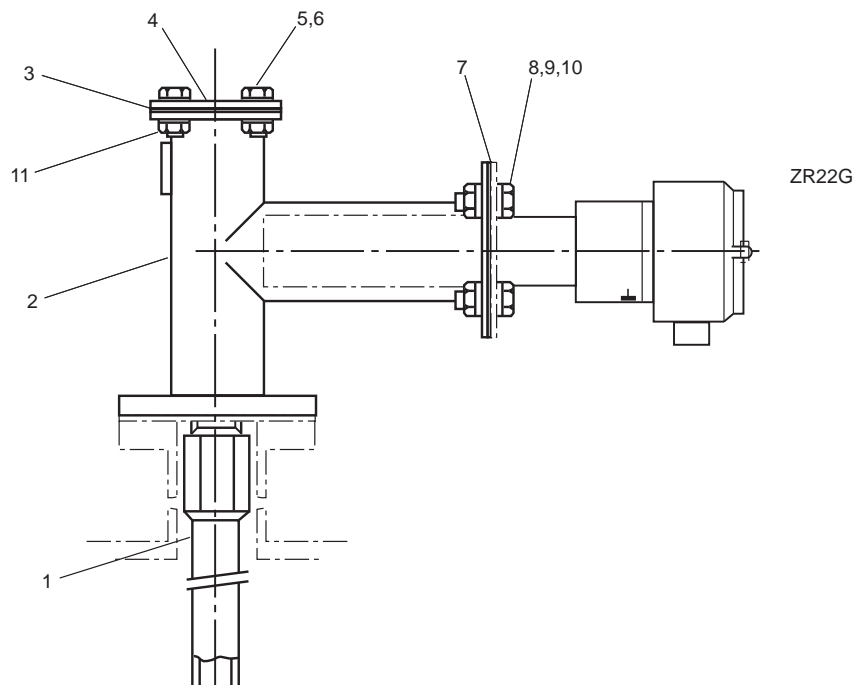

Item	Part No.	Qty	Description	Item	Part No.	Qty	Description	
1	K9292TP	1	Probe (SiC, L=0.5m)	2	E7046FA	1	Probe Adaptor (for JIS 5K-50-FF)	
	E7046CF	1	Probe (SiC, L=0.6m)		E7046FE	1	Probe Adaptor (for ANSI CLASS150-4-RF)	
	K9292TQ	1	Probe (SiC, L=0.7m)		E7046FK	1	Probe Adaptor (for DIN PN10-DN50-A)	
	E7046CG	1	Probe (SiC, L=0.8m)		E7046FD	1	Probe Adaptor (for JIS 10K-100-FF)	
	E7046CH	1	Probe (SiC, L=0.9m)		E7046FC	1	Probe Adaptor (for JIS 10K-80-FF)	
	E7046AL	1	Probe (SiC, L=1.0m)		E7046FB	1	Probe Adaptor (for JIS 10K-65-FF)	
	E7046BB	1	Probe (SiC, L=1.5m)		E7046FG	1	Probe Adaptor (for ANSI CLASS150-3-RF)	
	K9292TV	1	Probe (SUS, L=0.5m)		E7046FF	1	Probe Adaptor (for ANSI CLASS150-2 1/2-RF)	
	E7046CR	1	Probe (SUS, L=0.6m)		E7046FJ	1	Probe Adaptor (for JPI CLASS150-4-RF)	
	K9292TW	1	Probe (SUS, L=0.7m)		E7046FH	1	Probe Adaptor (for JPI CLASS150-3-RF)	
	E7046CS	1	Probe (SUS, L=0.8m)		3	E7046FQ	1	Gasket
	E7046CT	1	Probe (SUS, L=0.9m)		4	E7046FN	1	Plate
	E7046AP	1	Probe (SUS, L=1.0m)		5	Y9825NU	4	Bolt
	E7046AQ	1	Probe (SUS, L=1.5m)		6	Y9800WU	8	Washer
			7	G7073XL	1	Gasket		
			8	Y9630RU	4	Bolt		
			9	Y9121BU	4	Nut		
			10	Y9120WU	4	Washer		
			11	Y9801BU	4	Nut		





# Customer Maintenance Parts List

E7046EC/E7046EN  
Zirconia Oxygen Analyzer  
Auxiliary Ejector Assembly (for Model ZO21P-H)

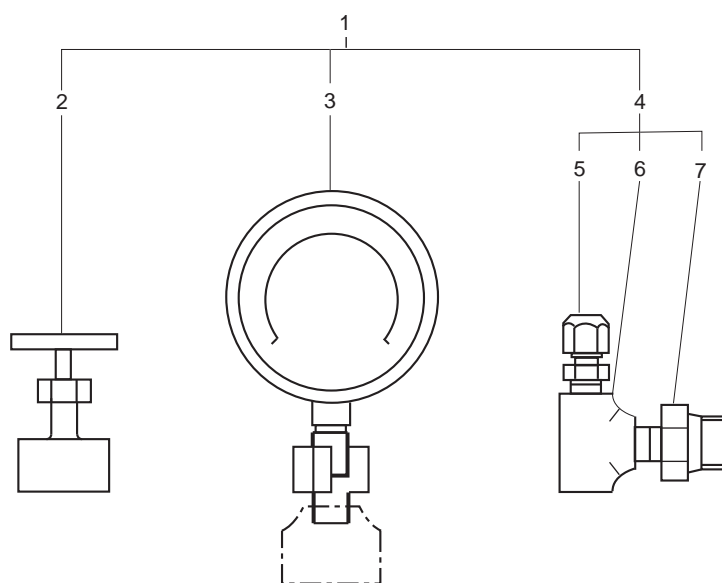

Item	Part No.	Qty	Description
1	E7046EC	1	Auxiliary Ejector Assembly, Connection Rc1/4
	E7046EN	1	Auxiliary Ejector Assembly, Connection 1/4 NPT
2	L9852CB	1	Needle Valve, Connection Rc1/4
	G7016XH	1	Needle Valve, Connection 1/4NPT
3	E7046EK	1	Pressure Gauge, Connection Rc1/4
	E7046EV	1	Pressure Gauge, Connection 1/4NPT
4	E7046ED	1	Ejector, Connection Rc1/4
	E7046EP	1	Ejector, Connection 1/4NPT
5	E7046EF	1	Nozzle Assembly, Tube Connection $\varnothing 6 \times \varnothing 4$ tube
	E7046ER	1	Nozzle Assembly, Tube Connection 1/4 inch tube
6	G7031XA	1	Tee, Connection Rc1/4
7	E7046EJ	1	Reducing nipple, Connection R1/4



# Customer Maintenance Parts List

Model ZO21S  
Zirconia Oxygen Analyzer/ High Temperature  
Humidity Analyzer, Standard Gas Unit

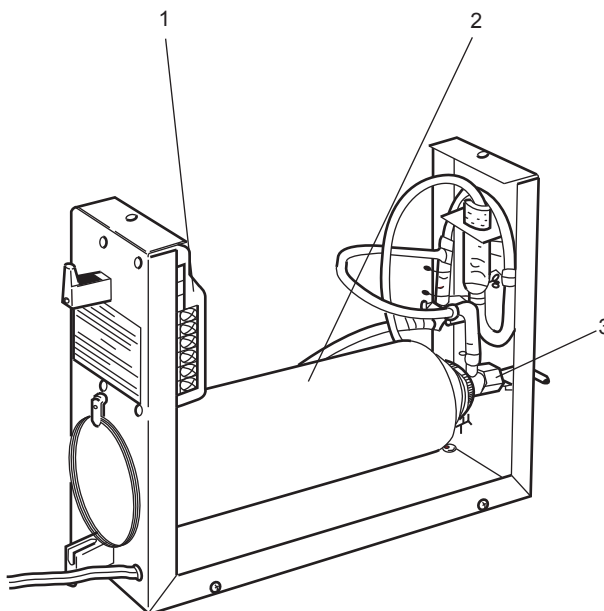

Item	Part No.	Qty	Description
1	—	1	Pump (see Table 1)
2	E7050BA	1	Zero Gas Cylinder (x6 pcs)
3	E7050BJ	1	Needle Valve

Table 1

Power	Pump
AC 100 V 110 115	E7050AU
AC 200 V 220 240	E7050AV



# Revision Information

- Title : Model ZR22S, ZR402G Separate type Explosion-proof Zirconia Oxygen Analyzer
- Manual No. : IM 11M13A01-02E

## May 2022/15th Edition

Added EN IEC 61000-3-2 (page 2-2)  
Updated EU-DoC.

## Nov. 2021/14th Edition

Updated the NAME PLATE. (page 2-3, 2-4)  
Added the operation procedure (pages 3-2)

## June 2021/13th Edition

Revised RoHS conformity standards. (page 2-2), Corrected (pages vii, 2-2, 2-3, 3-2, 3-3),  
Changed EU Declaration of Conformity

## Mar. 2020/12th Edition

Added a suffix code (-P) on Model and Code (page 2-16)

## Oct. 2019/11th Edition

Corrected. (page 2-13)  
Added a figure of dimension (page. 2-8)  
CMPL 11M13A01-02E revised to 5th edition.

## Feb. 2019/10th Edition

Added EAC Flameproof certificate description. (page 2-4)

## May 2018/9th Edition

Added WEEE directive information.(pages viii, 2-2)  
KOSHA approval ZR22S-K (pages 2-5, 2-6)

## Feb. 2018/8th Edition

Corrected flange size of blow pipe, etc. (pages 2-6, 4-10)

## Jul. 2017/7th Edition

Changed flange materials of ZR22S, ZO21R and ZO21P. (pages 2-5 to 2-11)

## June 2017/6th Edition

Added RoHS compliance statement with some revision on pages i, iv, vii,2-1, 2-2, 2-4, 2-5, 2-6, 3-1,  
3-2, 3-3, 3-5, 3-6.

## Apr. 2016/5th Edition

Addition the related documents, etc.  
CMPL 11M13A01-02E revised to 4th edition.

## Aug. 2015/4th Edition

Revised section  
2.1.1 “ZR22S Separate type Explosion-proof Detector “ NAME PLATE:  
Addition of the maximum surface temperature for dust-proof.  
“General Specifications”: Added to “Standard Specifications”  
2.7.2 “Stop Valve”: Changed of the weight and external dimensions.  
2.7.3 “Check Valve”: Changed of the weight.

## Nov. 2014/3rd Edition

Revised and Corrected over all

## Jul. 2006/2nd Edition

Introduction Warning about Explosion-proof: Deleted description.  
Introduction Explosion-proof Approval: Added description.  
2.2.1 “ZR22S Separate type Explosion-proof Detector”: Added description.  
2.2.1 “ZR22 Separate type Explosion-proof Detector”: Added description.

- 
- 2.5 Model and Suffix Code: Added one suffix code.
  - 2.7.5 “Cylinder Regulator value (Part No. G7013XF or G7014XF)”: Change drawing.
  - 3.1.5 “IECEX Flameproof Type”
  - 8.2.3 “Output Hold Setting”: Changed value in Figures 8.2 and 8.3.
  - 8.2.4 “Default Values”: Changed descriptions in Table 8.2.
  - 8.6.4 “Setting Purging”: Added item.
  - 8.6.5 “Setting Passwords”: Changed Section number.
  - 10.3 “Operational Data Initialization”: Changed value in Table 10.5.
  - 12.2.2 Alarm 6: Changed descriptions, Alarm 7: Changed descriptions.
  - CMPL 11M12A01-02E: Changed part numbers

**Apr. 2005/1st Edition**

Newly published

---

Yokogawa Electric Corporation  
2-9-32 Nakacho, Musashino-shi, Tokyo 180-8750, JAPAN  
Homepage: <http://www.yokogawa.com/>

---

# EU DECLARATION OF CONFORMITY

We **Yokogawa Electric Corporation**  
**2-9-32 Nakacho, Musashino-shi, Tokyo, 180-8750 Japan**

declare under our sole responsibility that the Products identified as:

Model code <b>ZR22S</b>	Model name <b>Separate type Explosion-proof Zirconia Oxygen Analyzer, Detector</b>
----------------------------	---

specified with the first suffix code: **-A**

as part of Product Family: **EXAxt**  
 further specified with model suffix and option codes:

**as listed in General Specification: GS 11M13A01-01E (Ed.13)**  
 See Appendix 2 for additional information.

are in compliance with the EU law and legislation providing for the CE-marking, as listed in Appendix 1.

Information relevant to the conformity and identification of these Products is provided in Appendix 2, Appendix 3 and Appendix 4.

Subject products are:

- Produced according to appropriate quality control procedure.
- Provided with the CE-marking as from **2005**.

Signature:

(Manufacturer)

Tokyo, 20 April 2022



.....  
 Tetsuo Ooshita  
 General Manager  
 Analyzer Development Dept.  
 Development Div. Sensing Center  
 Yokogawa Products HQ  
 Yokogawa Electric Corporation

(Authorized Representative in the EEA)

Amersfoort, 09 May 2022

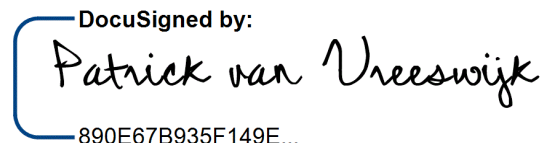
DocuSigned by:  
  
 890E67B935F149E...

.....  
 Patrick van Vreeswijk  
 QHSE Manager – Regional Business Owner  
 Yokogawa Europe B.V.  
 Euroweg 2, 3825 HD Amersfoort,  
 P.O.Box 163, 3800 AD Amersfoort,  
 The Netherlands



## Appendix 1

The products are built in compliance with requirements of the following EU Directives and Standards:

Model – Suffix / Option code structure: **ZR22S – A – ccc – d – e – f – g – h – i – j / x**  
(Distinctive combinations of suffix and option codes as indicated per table. Unless otherwise stated, it means all defined codes are relevant.)

EU Directive	Standards
<b>2014/30/EU</b> (EMC)	<p><b>EN 61326-1:2013 Class A Table 2</b> Electrical equipment for measurement, control and laboratory use – EMC requirements- Part 1: General requirements</p> <p><b>EN 61326-2-3:2013</b> Electrical equipment for measurement, control and laboratory use – EMC requirements – Part 2-3: Particular requirements - Test configuration, operational conditions and performance criteria for transducers with integrated or remote signal conditioning</p> <p><b>EN 61000-3-2:2014</b> <b>EN IEC 61000-3-2:2019</b> Electromagnetic compatibility (EMC) -- Part 3-2: Limits - Limits for harmonic current emissions (equipment input current ≤ 16 A per phase)</p>
<b>2014/35/EU</b> (LVD)	<p><b>EN 61010-1:2010+A1:2019</b> Safety requirements for electrical equipment for measurement, control, and laboratory use – Part 1: General requirements</p> <p><b>EN 61010-2-030:2010</b> Safety Requirements for Electrical Equipment for Measurement, Control and Laboratory Use, Part 2-030: Particular requirements for testing and measuring circuits</p>
<b>2011/65/EU</b> *1,2 (RoHS)	<p><b>EN IEC 63000:2018</b> Technical documentation for the assessment of electrical and electronic products with respect to the restriction of hazardous substances.</p>
<b>2014/34/EU</b> *3 (ATEX)	<p><b>EN IEC 60079-0:2018</b> Explosive atmospheres Part 0: Equipment-General requirements</p> <p><b>EN 60079-1:2014</b> Explosive atmospheres Part 1: Equipment protection by flameproof enclosures “d”</p> <p><b>EN 60079-31:2014</b> Explosive atmospheres Part 31: Equipment dust ignition protection by enclosure “t”</p> <p> <b>II 2 G Ex db IIB+H<sub>2</sub> T2 Gb</b> <b>II 2 D Ex tb IIIC T300°C Db</b></p> <p>The Number of the EU Type-Examination Certificate: <b>KEMA 04ATEX2156 X</b></p> <p>EU Type Examination Certificate listed above and Quality Assurance Notification are issued by: The Name of the Notified Body: <b>DEKRA Certification B.V.</b> The Identification Number of the Notified Body: <b>0344</b> The Address of the Notified Body: <b>Meander 1051 6825 MJ Arnhem, The Netherlands</b> The Number of Quality Assurance Notification: <b>DEKRA 11ATEXQ0127</b></p>

\*1: Including the Commission Delegated Directive (EU) 2015/863 that defines the ten (10) restricted substances and amends Annex II to Directive 2011/65/EU.

\*2: Products on and after the production date of June 1<sup>st</sup> 2021 are the RoHS compliant products. Production date is indicated following the serial number and is located on the right side of the frame of “NO.” in the name plate. Year and Month of the production are indicated such as ‘2021.06’.

\*3: The listed standards have been compared to the standards EN 60079-0:2012+A11:2013, EN 60079-1:2014 and EN 60079-31:2014 used for certification purposes, but no clauses containing changes in state-of-art apply to this product.

---



---

## Appendix 2

---



---

In case the Product model code contains the code "Z", it means that the Product is produced with a customer specific modification. Any such Product - in case produced after the date of signing this document by the Manufacturer - is also in scope of this EU-Declaration of Conformity. The code "Z"- specific application notes and Serial Numbers of Products subject to this modification are listed in a dedicated document, of which original is a part of the Technical Documentation. A copy of that document is accompanying each product at delivery.

---



---

## Appendix 3

---



---

The accessories in the list below have CE-marking significant compliance relevance, as indicated per EU-Directive; their application and use – as described in **IM 11M13A01-02E** – is supported by this EU Declaration of Conformity. The full list of accessories for this product can be found in **IM 11M13A01-02E**.

**Indications:** 'C' = *The accessory conforms to the Directive as a part of the product.*

'R' = *The accessory is relevant to the conformity of the product as a part of the product.*

'NS' = *The accessory does not support the Directive.*

'NR' = *The accessory is not relevant to the conformity of the product.*

Model No.	Model Name	Relevant EU Directives			
		EMC	LVD	RoHS	ATEX
ZO21P	High Temperature Probe Adapter	NR	NR	C	NR
ZO21R	Probe Protector	NR	NR	C	NR
ZR22A	Heater Assembly	C	C	C	NR
IM 11M13A01-02E	User's Manual	R	R	R	R

## Appendix 4

External View of ZR22S



Image of Nameplate  
(Typical example; details may differ)

<b>ZIRCONIA DETECTOR</b>		<div style="text-align: center;"><b>⚠ WARNING</b></div> <ul style="list-style-type: none"> <li>· DO NOT OPEN WHEN AN EXPLOSIVE GAS ATMOSPHERE IS PRESENT</li> <li>· POTENTIAL ELECTROSTATIC CHARGING HAZARD - READ USER'S MANUAL (IM 11M13A01-02)</li> <li>· FOR INSTALLATION AND SAFE USE, READ IM 11M13A01-02</li> </ul> <div style="text-align: center;"><b>⚠ HIGH TEMPERATURE</b></div> <ul style="list-style-type: none"> <li>· USE AT LEAST 150°C HEAT RESISTANT CABLES &amp; CABLE GLANDS</li> </ul> <div style="text-align: right;"><b>IP66 Um=240VAC</b> </div>
<b>MODEL</b>	<b>ZR22S</b>	
<b>SUFFIX</b>	<b>-A-040-S-E-E-T</b>	
	<b>-M-E-A/SV</b>	
<b>STYLE</b>	<b>S1</b>	
<b>AMB.TEMP</b>	<b>-20 TO 60°C</b>	
<b>NO.</b>	<b>91XX12345 2021.06</b>	
<b>CE 0344 Ex II 2GD</b>		
<b>No. KEMA 04ATEX2156 X</b>		
<b>Ex db IIB+H<sub>2</sub> T2 Gb</b>		
<b>Ex tb IIIC T300°C Db</b>		
<b>YOKOGAWA</b> <b>Made in Japan</b>		Yokogawa Electric Corporation Tokyo 180-8750 JAPAN

-/-

Thank you for purchasing the ZR22S Explosion-proof detector.

#### ◆ When using ZR802G for the converter, refer to ZR802G manuals.

ZR802G manuals are as follows:

##### General Specifications

Contents	Document number
ZR22G, ZR802G, and ZR202G Zirconia Oxygen/Humidity Analyzer	GS 11M12G01-01EN

\* the "EN" in the document number is the language code.

##### User's Manual

Contents	Document number
ZR22G and ZR802G Zirconia Oxygen/Humidity Analyzer	IM 11M12G01-02EN
ZR802G Zirconia Oxygen/Humidity Analyzer, Converter Start-up and Safety Precautions	IM 11M12G01-01Z1

\* the "EN" in the document number is the language code.

##### Technical Information

Contents	Document number
ZR802G Zirconia Oxygen/Humidity Analyzer, Converter HART Communication	TI 11M12G01-61EN
ZR802G Zirconia Oxygen/Humidity Analyzer, Converter MODBUS Communication	TI 11M12G01-62EN

For latest User's Manual, download it from our website or scan QR code.

<http://www.yokogawa.com/an/zr802/download/>

