

# O<sub>2</sub> Learning Handbook

Zirconia Crystal Clear

# Table of Contents

1. Introduction.....	4
2. Theory.....	4
2.1 Why Measure O <sub>2</sub> ? .....	5
2.2 Oxygen Measurement Principle and Theory .....	6
2.3 Humidity Measurement Principle and Theory.....	8
2.4 Units of Measure .....	8
2.4.1 Absolute Humidity.....	8
2.4.2 Relative Humidity.....	8
2.4.3 Dew Point .....	9
2.4.4 Mixing Ratio .....	9
2.4.5 Other Units.....	9
2.4.6 Accuracy of the Humidity Analyzer.....	9
2.5 Comparison and Advantage over Competitive O <sub>2</sub> Principles.....	9
2.5.1 Paramagnetic.....	9
2.5.2 Electrochemical.....	10
2.5.3 Optical: Tunable Diode Laser Spectroscopy.....	10
3. Yokogawa Products and Features .....	12
3.1 Zirconia Oxygen Detector, Model ZR22 .....	12
3.2 Construction and Features of a Zirconia Cell .....	12
3.3 Zirconia Oxygen Pressure Compensation, Model ZR22G-P .....	12
3.4 Zirconia Oxygen High Temperature Adapter.....	13
3.5 Calibration Equipment.....	14
3.6 Filters and Accessories.....	16
3.7 Probe Protectors and Probe Supports.....	17
3.8 Zirconia Oxygen Single Unit Analyzer, Model ZR402G.....	18
3.9 Zirconia Oxygen Multi Unit Averaging Analyzer, Model AV550G .....	18
3.10 Integral Type Zirconia Oxygen Detector and Analyzer, Model ZR202 .....	19
3.11 Zirconia Oxygen Low Concentration Analyzer, Model OX400.....	19
3.12 Limiting Current Type Oxygen Analyzer.....	20
3.12.1 Model OX100 .....	20
3.12.2 Model OX102 .....	20
4. Application Notes.....	23
4.1 Boiler.....	26
4.1.1 Package boiler.....	26
4.1.2 Power generation boiler (Heavy oil, Gas).....	27
4.1.3 Pulverized coal boiler.....	28
4.1.4 Black liquor recovery boiler.....	29
4.2 Iron and Steel Furnaces.....	30
4.2.1 Iron & steel heating furnace .....	30
4.2.2 Hot blast stove (blast furnace facility) .....	31
4.2.3 Coke oven facility.....	32
4.2.4 Soaking pit.....	33
4.3 Ceramic, Brick, Glass & Cement Furnaces/ Kilns.....	34
4.3.1 Rotary type lime kiln.....	34
4.3.2 Cement kiln (cyclone outlet gas) .....	35
4.4 Petroleum Refining and Petrochemical Fired Heaters .....	36
4.4.1 Naphtha cracking furnace.....	37
4.4.2 Petroleum refinery process fired heater example .....	38
4.5 Garbage Incinerator.....	39
4.6 Non-Combustion Applications.....	40
4.6.1 Oxygen enrichment facility .....	40
4.6.2 Power generation boiler wind box .....	41
4.6.3 Aeration tank.....	42
4.7 Difficult Measurement Applications.....	43
4.7.1 Glass melting furnace (in-furnace gas) .....	43
4.7.2 Calcination furnace .....	44
4.7.3 Facilities with reducing gas atmospheres .....	44
5. Installation Guide .....	44
5.1 What is in an Installation Loop .....	44
5.2 Zirconia Probe Installation .....	44
5.2.1 Location .....	44
5.2.2 Probe Insertion Hole.....	44
5.2.3 Installation of the Detector .....	45
5.3 Installation of Accessories and Parts.....	45

5.3.1 Filters.....	45
5.3.2 Check Valve (Option Code “/CV” .....	46
5.3.3 Probe Protector.....	46
5.3.4 Calibration Units.....	47
5.4 Installation of the High Temp Tee (ZO21P/ZR22P).....	47
5.4.1 Probe Insertion Hole .....	47
5.4.2 Probe Adapter .....	47
5.5 Installation of the Analyzer (ZR402G/AV550G).....	48
5.6 Installation of the Integral Zirconia Oxygen Analyzer (ZR202*) .....	48
5.7 Installation of the OX400 .....	48
5.8 Installation of the OX100/ OX102 .....	49
5.8.1 Installation of the Sensor .....	49
5.8.2 Installation of the Sampling Unit (K9424GA) .....	49
6. Selection Guide .....	49
6.1 Oxygen analyzer selection flow chart.....	49
6.2 System configuration.....	52
6.2.1 ZR402G/ZR22 Direct In Situ Zirconia Oxygen.....	52
6.2.2 Selection According to Use.....	53
6.2.3 Examples of System Component Selection Based on Sample Gas Conditions .....	57
6.3 Compatibility between old and existing models .....	60
7. Basic Steps for Maintenance and Trouble Shooting .....	60
7.1 Maintenance for ZR22 and ZR202.....	60
7.1.1 Cleaning the Calibration Gas Tube.....	60
7.1.2 Replacing the Sensor Assembly.....	60
7.1.3 Replacing the Heater Assembly.....	60
7.1.4 Replacement of Dust Filter.....	60
7.1.5 Replacement of the Fly Ash Filter .....	61
7.1.6 Replacement of O-ring.....	61
7.2 Calibration .....	61
7.2.1 Best Practices for Calibration.....	62
7.2.2 Calibration of the Humidity Analyzer .....	62
7.3 Trouble Shooting .....	62
7.3.1 Error and Alarm .....	62
7.3.2 Basic Zirconia Probe Check .....	63
7.3.3 Testing O2 Cell .....	64
7.3.4 My detector is reading a high O2 level .....	64
7.3.5 My detector is reading a low O2 leve.....	65
7.3.6 Other Abnormal Values .....	65
7.3.7 Experiencing Erratic Reading .....	65
7.3.8 Probe Temperature low and not warming up .....	65
7.3.9 Probe Temperature Too High .....	66
7.3.10 High Impedance Reading (Zirconia cell & contact resistance & lead resistance) .....	66
7.3.11 Short Sensor Life .....	66
7.3.12 Short Heater Life.....	66
7.3.13 Automatic Calibration Panel, Model AC8.....	66
8. Zirconia Analyzer – Question & Answers .....	67
8.1 Application .....	67
8.2 Installation .....	69
8.3 Maintenance .....	69
8.4 Accessories.....	73
8.5 Models .....	73
9. Lock Out Specifications .....	73
9.1 Oxygen Analyzer System Specification for a Single Channel Analyzer and Detector Requirements .....	73
9.2 Oxygen Analyzer System Specification for an Integrated type Oxygen Analyzer and Detector Requirements .....	75
9.3 Oxygen Analyzer System Specification for Multi-Channel Averaging Oxygen Analyzer and Detector Requirements .....	76
10. Customer Application Data Sheet.....	79

# 1. Introduction

Successful industrial product sales requires strong technical and application knowledge of the equipment involved as well as a comprehensive understating of the market 's competitive elements, such as features, benefits and pricing. This handbook has been designed as an ongoing sales tool, which will be updated and amended on a regular basis to help keep the sales force abreast of new market developments based on process/application improvement as well as new product developments.

Oxygen concentration measurements are used in a variety of applications including, energy conservation, pollution reduction and process quality control and accomplished using several different measurement principals. Even Governmental regulations to control CO<sub>2</sub> and NO<sub>x</sub> emissions, affect even small municipal, private and commercial utility boilers and furnaces as they must be controlled or at least tested on a regular basis. However, Zirconia-based Oxygen Analyzers are most commonly used for combustion control, burner optimization and to increase the efficiency of boilers and industrial heaters to achieve fuel conservation. Major end-users are found in the following industrial fields:

- Electrical Power Generation
- Chemical and Petrochemical
- Iron and Steel Manufacturing
- Petroleum Refinery
- Pulp & Paper
- Textiles

There are still countries where extractive oxygen analyzer systems are in use for combustion control (paramagnetic, TDLS, thermo-magnetic, polarographic, electrochemical, fuel-cell). These offer an excellent sales opportunity since the advantages and benefits of zirconia analyzers over extractive methods are easily demonstrated. The following are some of the benefits and features of the Yokogawa Zirconia Oxygen Analyzers:

- Compact design for flexible low-cost installation
- Long-life sensor
- Reduced maintenance and calibration using self-diagnostics
- Excellent price/ performance correlation

Yokogawa's Zirconia Oxygen analyzer can also be used to measure humidity in specific applications. This is a benefit because most humidity analyzers are normally designed for ambient temperatures and not suitable for the high temperatures that we find in bakery ovens, Pizza ovens, Paper driers or Plywood driers. The zirconia high temperature analyzer is designed to measure oxygen concentrations in the air and calculate

the moisture content; a type of humidity measurement that is more commonly referred to as Absolute Humidity. It is important to note that moisture content in anything other than air, i.e. combustion exhaust gas, cannot be measured.

However, no matter the desired measurement some common difficulties that you will face are:

- A variety of established competitors
- Conservative end-users who are reluctant to switch from one supplier to another
- A growing number of government regulations

# 2. Theory

Plant boilers are closed vessels in which water under pressure is transformed into steam by the application of heat. In the boiler furnace, the chemical energy in the fuel is converted into heat, and it is the function of the boiler to transfer this heat to the water it contains in the most efficient manner possible. Most often the boiler is designed to generate high quality steam for use throughout the plant. The fuel that is used for heating the boiler may either be: Gaseous such as natural gas, cokes-oven gas/ blast furnace gas; Liquid, such as heavy/light fuel oil, jet oil, liquefied petroleum gas, gasoline, nafta or chemical waste; or Solid such as wood/bark, coal, brown coal, or peat.

Perfect combustion occurs when the correct amounts of fuel and oxygen are combined so that both are totally consumed, with no combustibles or uncombined oxygen remaining in the resulting flue gas. Under ideal conditions, combustion-reaction obeys the following stoichiometric reaction equation:



However, fuel may contain impurities and additives to improve viscosity, therefore ideal combustion can only be achieved if all of the following requirements are met simultaneously:

- Consistent fuel composition at all times
- Pure oxygen in used instead of simple plant air
- Complete molecular mixing of oxygen and fuel, at the same temperature and pressure
- Unlimited reaction time and zone
- Constant in-outlet conditions (pressure, temperature, flow, composition) are maintained
- Consistent boiler/furnace load

In practice, none of the above requirements are completely achieved due to the physical restrictions in burner design, use of (economical) ambient air rather than expensive pure oxygen, and aging of boiler equipment.

When there is insufficient air for combustion control, the fuel is not completely consumed and gives off smoke. This is a sign of energy loss and undesirable emissions. If left unchecked the buildup of combustibles will lead to a safety hazard. On the other hand, if excess air for combustion is supplied, the unused air is overheated and emitted from the stack, causing a heat loss. This increases the emissions of NO<sub>x</sub> and SO<sub>2</sub>, which cause air pollution. In order to achieve complete combustion there must be a balance or air-fuel ratio where the boiler is operating as close to zero "excess air" as possible.

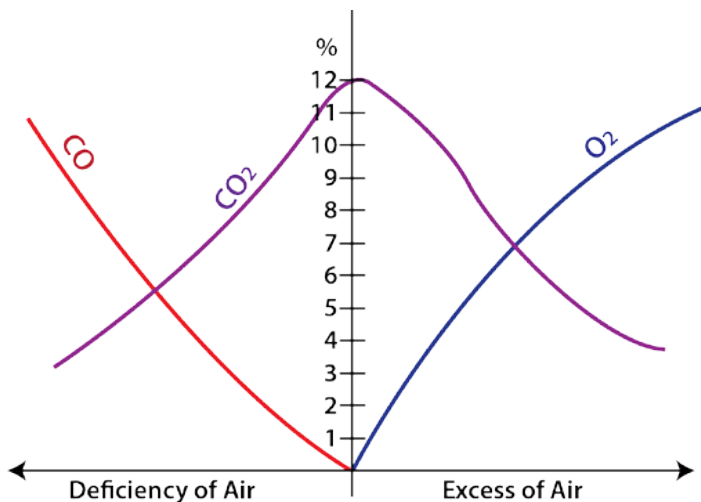

Figure 2.1 Example of Environment

## 2.1 Why Measure O2?

Either the measurement of oxygen or carbon monoxide can be used to determine the level of excess air. However, measuring CO alone will not define which type of an environment, fuel rich or air rich, a burner is operating in. Therefore combustion control needs to be based on accurate and dependable Oxygen analysis. To ensure complete combustion chamber are supplied with excess air to increase the amount of oxygen and the probability of combustion of all fuel. The combustion efficient will increase with increased excess air, until the heat loss in the excess air is larger than the heat provided by more efficient combustion.

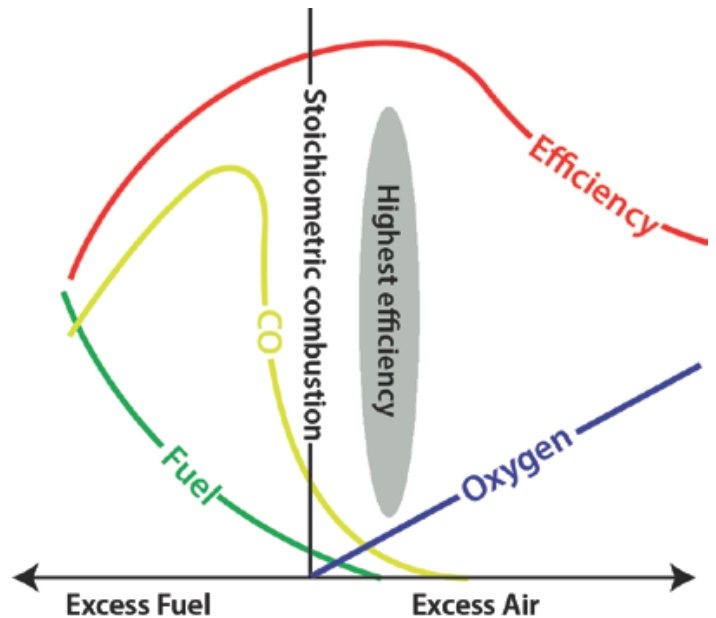

Figure 2.2 Efficiency Graph

"Air-fuel ratio" or "Excess air" refers to the amount of air theoretically required to achieve complete combustion of the fuel supplied to the furnace of the boiler. The "air-fuel ratio" or "excess air" is used to achieve the highest efficiency for a system based on each different fuel source. "Excess air" can be obtained by measuring the oxygen concentration in the exhaust gas and calculated by:

$$n = (1 / (21 - \text{Oxygen concentration})) \times 21$$

Data is available that shows the various fuel sources and an indication of their typical value for excess air; shown in the table below are just a few of the common fuel sources:

Fuel	Excess of Air (%)
Coke oven gas	5-10
Natural Gas	5-10
Coal, pulverized	15-20
Coal, stoker	20-30
Oil (No. 2 and No. 6)	10-20

Under actual operating conditions some amount of excess air is always necessary to bring the combustibles level close to zero. The challenge is to minimize these effects by achieving completed combustion with the lowest excess air levels possible. It is important to accurately measure and control oxygen analysis because:

- Insufficient air is a waste of fuel which is a waste of money. As a rule of thumb each 10% excess O<sub>2</sub> is equivalent to a 1% in wasted fuel.

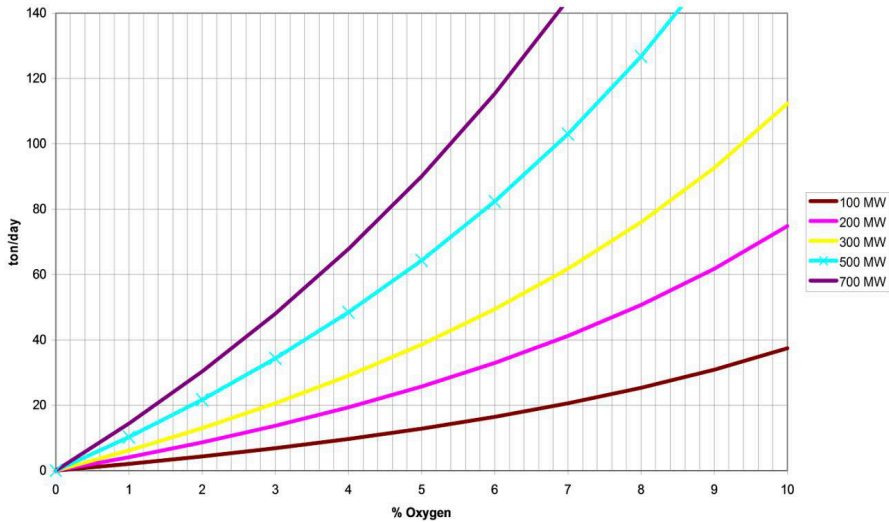

Figure 2.3 Fuel Consumption as a function of Oxygen Concentration

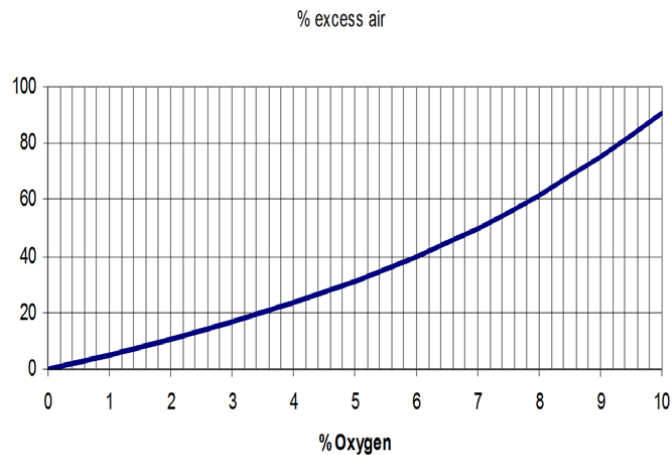

Figure 2.4 % Excess air Vs. Oxygen Concentration

- To minimize heat loss since the more excess-air used, the more heat required to warm it prior to combustion resulting is wasted heat contained in the waste gas carried to the stack.
- Optimizing fuel consumption by maintaining complete combustion.
- Minimizing power consumption by ancillary devices (air blowers; damper positioners).
- Reduction of air pollution since a surplus of excess air at high temperatures allows for the formation of  $SO_2$ ,  $SO_3$  and  $NO_x$  from the fuel impurities and air-nitrogen.

## 2.2 Oxygen Measurement Principle and Theory

The most common oxygen measurement methods are; Zirconia type systems, Paramagnetic, Electrochemical, and optical type systems. Each of these measurement methods has advantages and disadvantages, therefore it is important to select the appropriate method for each application. Section 2.5 explains the

basic measurement principles and the advantages/disadvantages for paramagnetic, electrochemical and optical measurement types.

There are two different types of Zirconia measurement systems; the amperometric which is used in Yokogawa products such as the OX100 and OX102, and the most common type is what is known as potentiometric. This type is used in Yokogawa products such as the ZR series and the OX400.

Figure 2.5 shows a schematic of the amperometric system. An amperometric sensor consists of a zirconia cell that has a high voltage being applied across the two platinum electrodes. Oxygen then flows thru the diffusion hole and comes into contact with the cathode of the heated zirconia element. As the Oxygen interacts with the cathode a current is generated. The measured current is proportional to the diffusion rate from the sample gas to the cathode. This output current is linear to the oxygen concentration.

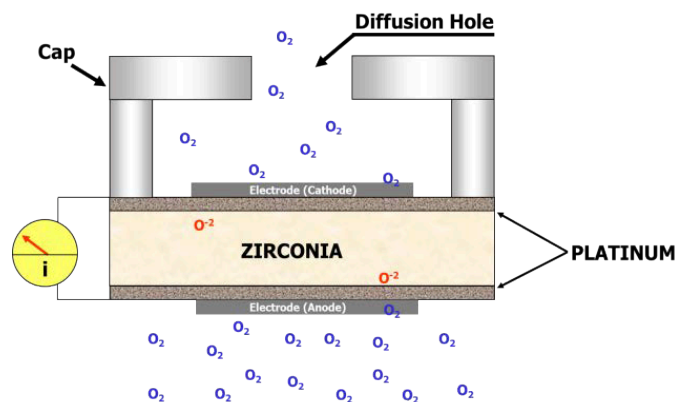

Figure 2.5 Amperometric measurement principle

Advantages to this type of system are this it is capable of measuring trace oxygen concentration from ppm to percentage level, and calibration is required only on the span side (air). The disadvantages are that if the sample gas contains a flammable gas, a measurement error occurs, and presence of dust causes clogging of the gas diffusion holes on the cathode side; a filter must be installed in a preceding stage.

Figure 2.6 shows the basic potentiometric method which uses a solid electrolyte such as zirconia with platinum electrodes attached that when heated the device acts as an oxygen concentration cell.

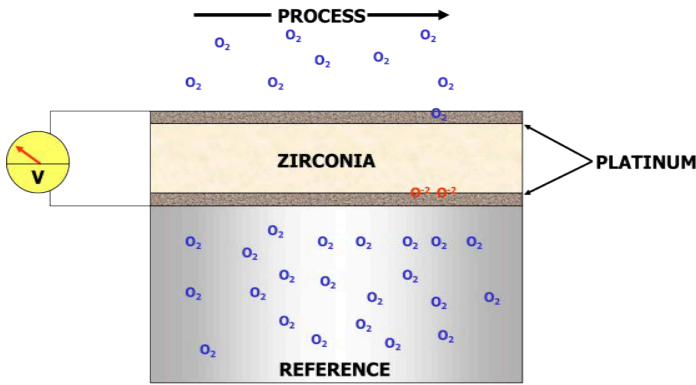

Figure 2.6 Potentiometric measurement principle

Basically a concentration gradient of Oxygen ions is established within the Zirconia lattice which produces a voltage potential between the platinum electrodes according to the NERNST equation:

$$E = - \frac{RT}{nF} \ln \frac{P_X}{P_A}$$

Where, R: Gas Constant

N: 4

F: Faraday's constant

T: Absolute temperature

PX: Oxygen concentration in a gas (measurement gas) in contact with the positive electrode (%)

PA: Oxygen concentration in a gas (reference air) in contact with the negative electrode (%)

The Zirconia becomes conductive only at high temperatures: above 600°C. Yokogawa uses a heater that controls the temperature of the Zirconia to 750°C. At that temperature the equation becomes:

$E = E_0 - 50.74 \log \frac{P_X}{P_A}$ , which equals  $E = -50.74 \log \left( \frac{O_2}{21} \right)$  when instrument air is used as reference gas and when pressure is equal on both sides.

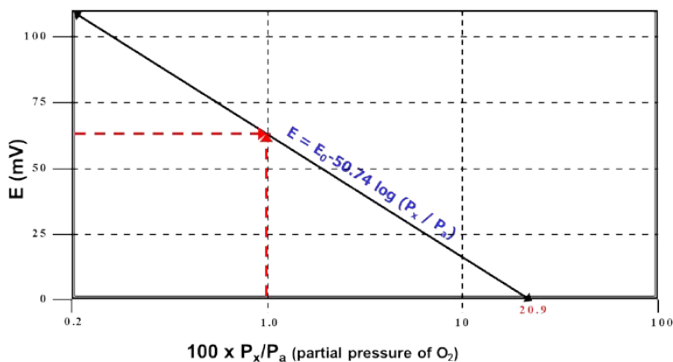

Figure 2.7 Oxygen partial pressure vs. Zirconia cell mV output (on basis of 21.0% O<sub>2</sub>)

If the Oxygen concentration on both sides of the Zirconia is equal then the ions move randomly through the crystal and no voltage is generated. However, if the concentration is different on both sides, then the ions move to the low concentration side because there

is equilibrium between Oxygen molecules and ions. The relationship between the voltage generated and the O<sub>2</sub> partial pressure is logarithmic. The Oxygen molecules react in the following manner:

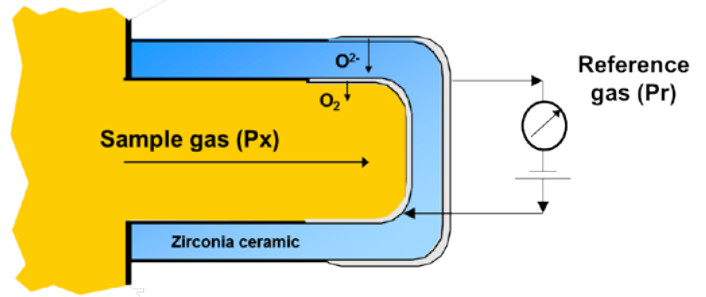

Figure 2.8 Schematic

**Negative electrode** (Higher oxygen partial pressure side)  $O_2 + 4e \rightarrow 2O^{2-}$

**Positive electrode** (Lower oxygen partial pressure side)  $2O^{2-} \rightarrow O_2 + 4e$

When plant air is used as the reference gas, the theoretical relationship between the oxygen concentration of the measurement gas and the electromotive force of the zirconia sensor (= cell) is as shown in Figure 2.9. In practice, sensors will exhibit slight deviations from the theoretical value but this deviation is corrected when the sensor is calibrated.

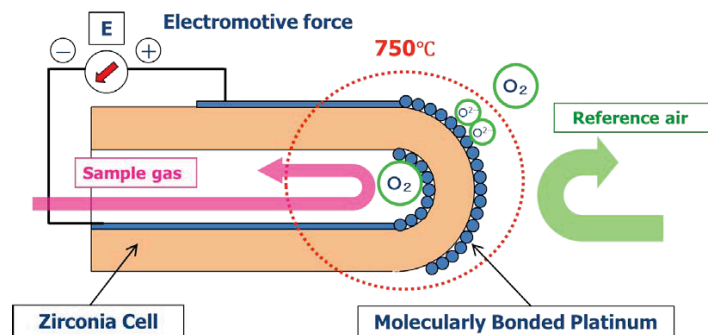

Figure 2.9 Schematic diagram of principle construction of the ZR22 Detector

It is important to note that the sensor (zirconia element) is heated to 750°C during measurements. If the process gas contains combustible gases such as carbon monoxide, hydrogen, and methane, these gases burn at the detector and consume oxygen, causing the oxygen concentration measured to be less than the actual value. Therefore, zirconia oxygen analyzers should be used only when the effect of coexisting combustible gases can be ignored or when their effect on oxygen concentration can be corrected. Generally, exhaust gases after combustion that are emitted from combustion equipment such as boilers and industrial furnaces have been completely burned; therefore the volume of combustible gases is very small in comparison with oxygen and their influence can be ignored.

Advantages versus conventional (extractive) methods are:

- Intrinsic fast response (within 5 seconds) due to no sampling system.
- In-situ measurement; direct insertion into the sample.
- Absence of moving parts.

Potential disadvantages are:

- Cell Fragility: May crack when exposed to thermal shocks or severe mechanical agitation which could generate false high output that may create hazardous situations.
- Cell output is dependent on differential O<sub>2</sub> pressure at the electrodes; requiring well defined reference gas. Cell output is also temperature dependent, especially at low O<sub>2</sub> levels.
- High operating temperature (600-1000°C) poses safety concerns as being a potential ignition source for combustible in the sample.

### 2.3 Humidity Measurement Principle and Theory

The Zirconia analyzer is designed to measure Oxygen at high temperatures. Humidity analyzers are normally designed for ambient temperature and not suitable for the high temperatures that we find in bakery ovens, Pizza ovens, Paper driers or Plywood driers.

If the Humidity measurement is needed in pure Air-Water gas mixtures, then the Oxygen analysis is suitable to measure the Water content of the gas.

This is the basic principle behind the Yokogawa High Temperature Humidity analyzers.

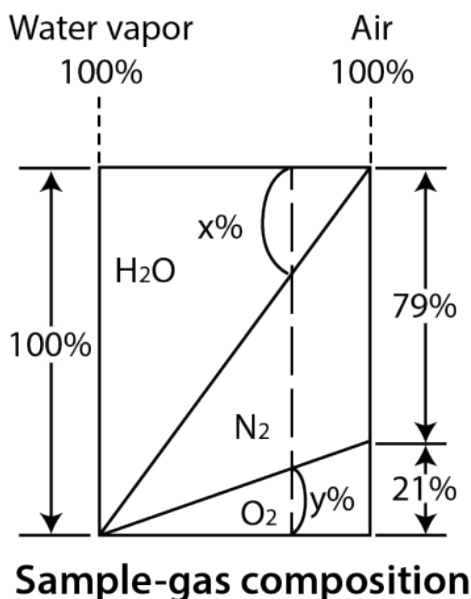

Figure 2.10

Figure 2.10 shows graphically, if the Oxygen concentration is y mol%, then the Air concentration is  $(100/21) * y$  mol%. For ideal gases the mol fraction is the same as the volumetric fraction, so 1 mol%= 1 vol%

The composition of dry air is:

78.084% Nitrogen, 20.946% Oxygen, 0.033% Carbondioxyde, 0.934% Argon In round figures: 21% Oxygen, 78% Nitrogen and 1% other gases.

The moisture content of the gas is 100 % minus the Air concentration in vol%

In other words: Moisture content: x is  $100 - y*(100/21)$

Graphical:  $x/100 = y/21$

### 2.4 Units of Measure

#### 2.4.1 Absolute Humidity

The absolute humidity is expressed as vol% H<sub>2</sub>O in gas, which is the primary unit displayed in the Zirconia high temperature analyzer.

#### 2.4.2 Relative Humidity

In ambient air conditions one uses normally rH as unit for humidity measurement. This is the relative humidity and it is the percentage of the maximum humidity at this temperature where the moisture will not condense. The Zirconia high temperature humidity analyzer can also display relative humidity, but only when a temperature input is given to the analyzer by means of a mA input of a temperature transmitter. In the following graph you see at what moisture concentration condensation occurs as function of the temperature.

For example at 30°C condensation occurs when the absolute humidity is 3 vol%. When the absolute humidity at 30°C is 2 vol%, then the relative humidity:  $rH = 2/3 = 67\%$ .



Saturation Fraction of Water in Air at Sea Level

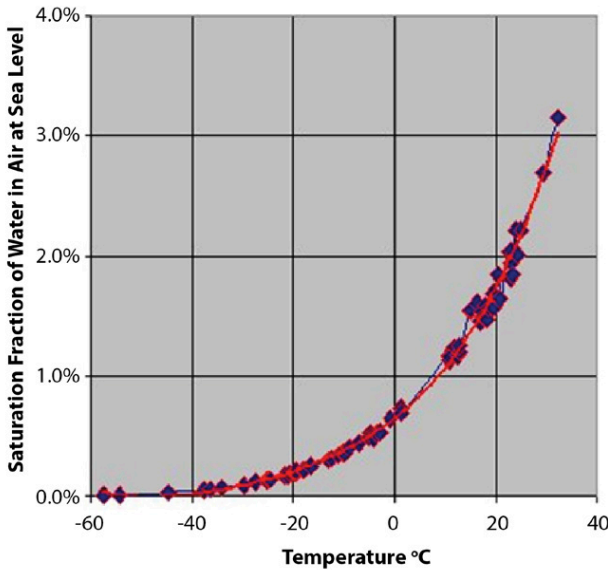

Figure 2.11

For applications of the Zirconia High Temperature Humidity analyzer the following chart is more useful.

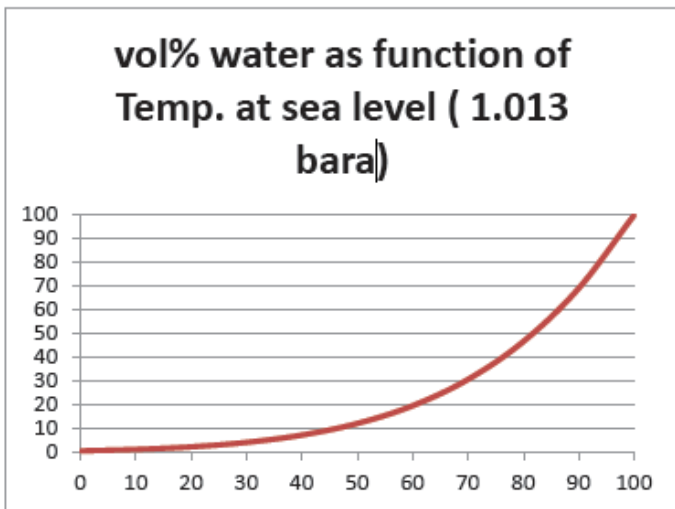

Figure 2.12

### 2.4.3 Dew Point

This unit is normally used to express the quality of Instrument Air. For those applications the Zirconia analyzer is not suitable, because the moisture content of instrument air is too low. In paper driers this may be an important parameter: it shows at what temperature condensation will occur.

The dew point is also shown in the charts shown above. The charts are only valid for standard barometric pressure: "sea level".

### 2.4.4 Mixing Ratio

The Zirconia Humidity analyzers have the possibility to choose Mixing Ratio as unit of measurement. This is the ratio: kg water/kg dry air. This unit of measurement is widely used for humidity control of driers. When the moisture concentration is x vol%, we can calculate the mixing ratio out of this value:

The molecular weight of water is 18 and the molecular weight of dry air is 28.8. Therefore; Y mol....

$$Y \text{ mol H}_2\text{O} = 18 \cdot x \text{ g/l water}$$

$$(100-x) \text{ mol Air} = 28.8 \cdot (100-x) \text{ g/l air}$$

So the mixing ratio of a gas with x vol% water is  $18/28.8 \cdot x / (100-x)$  or  $0.622 \cdot x / (100-x)$

### 2.4.5 Other Units

There are many other humidity units that are not supported by the Yokogawa Humidity analyzers. They can simply be calculated from the vol% H<sub>2</sub>O primary unit of measurement. Please consult Internet for the conversion factor. A complete set is found as HumiCalc on [www.thunderscientific.com](http://www.thunderscientific.com)

### 2.4.6 Accuracy of the Humidity Analyzer

The Humidity analyzer is measuring Oxygen, so the accuracy for the humidity readings is determined by the accuracy of the Oxygen analyzer.

The range of 0- 100 vol% H<sub>2</sub>O corresponds to a range of 21- 0 vol% O<sub>2</sub>. The repeatability of this analyzer is 0.5% FS= 0.1 vol% or 0.5 vol% H<sub>2</sub>O.

The range of 0- 25 vol% H<sub>2</sub>O corresponds to a range of 15.75 - 21 vol% Oxygen. The repeatability of this range is the same: 0.5 vol% H<sub>2</sub>O, which is now 2% FS.

These accuracy specifications are valid for process pressures of +/- 0.5 kPag or +/-5 mbarg and when dry instrument air is used as reference gas.

## 2.5 Comparison and Advantage over Competitive O2 Principles

### 2.5.1 Paramagnetic

This utilizes the fact that Oxygen is a paramagnetic gas which distinguishes oxygen from other gases because it is attracted into a strong magnetic field. Basically when a gas sample is introduced to the instrument the oxygen will be drawn into the magnetic field resulting in a change in the flow rate. The flowrate change is proportional to the oxygen concentration of the

sample gas. Paramagnetic analyzers may be used for measurement of oxygen at any level between 0-100%.

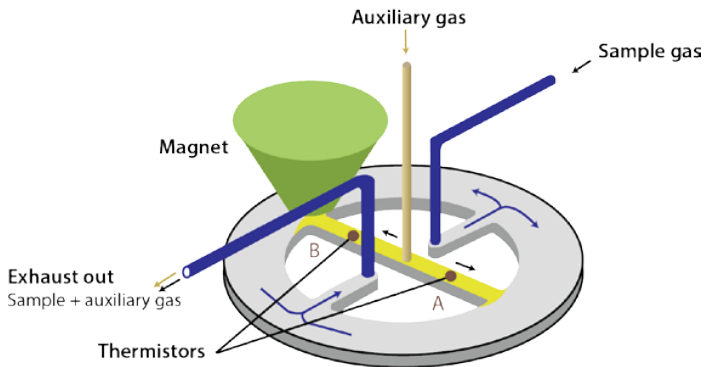

Figure 2.13 Paramagnetic Measurement Principle

**Advantages:**

- Capable of measuring flammable gas mixtures that cannot be measured by a zirconia oxygen detector with its heated cell.
- A paramagnetic system offers the fastest response time and is more resistant to vibration or shock.

**Disadvantages:**

- Some other gases, such as N<sub>2</sub>O, CO<sub>2</sub>, or NO<sub>2</sub>, are also paramagnetic and their presence in the gas stream can cause a false reading.
- Because of the sample system the response time is slow, sometimes up to 30 seconds or more.
- Require accurate temperature conditioning of detector and sample.
- Accurate flow and pressure control of the sample and auxiliary gas is needed.
- This method is also sensitive to fluctuations of ambient conditions, vibration and mechanical agitations, variations in background gases and detector drift.

**2.5.2 Electrochemical**

Electrochemical sensors, also known as fuel cells, measure percent or trace (ppm) levels of oxygen in a gas or gas mixture. Sensor consists of anode, membrane, a semi-solid electrolyte and a cathode. The oxygen will pass through the membrane/diaphragm in direct proportion to the partial pressure of the oxygen outside of the sensor. Oxygen enters the sensor and is reduced when it comes in contact with the cathode while the anode is oxidized in the following reactions:

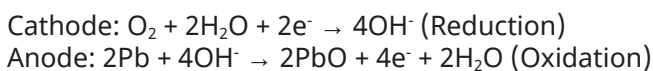

These two reactions produce a small current that is proportional to the amount of oxygen concentration reacting.

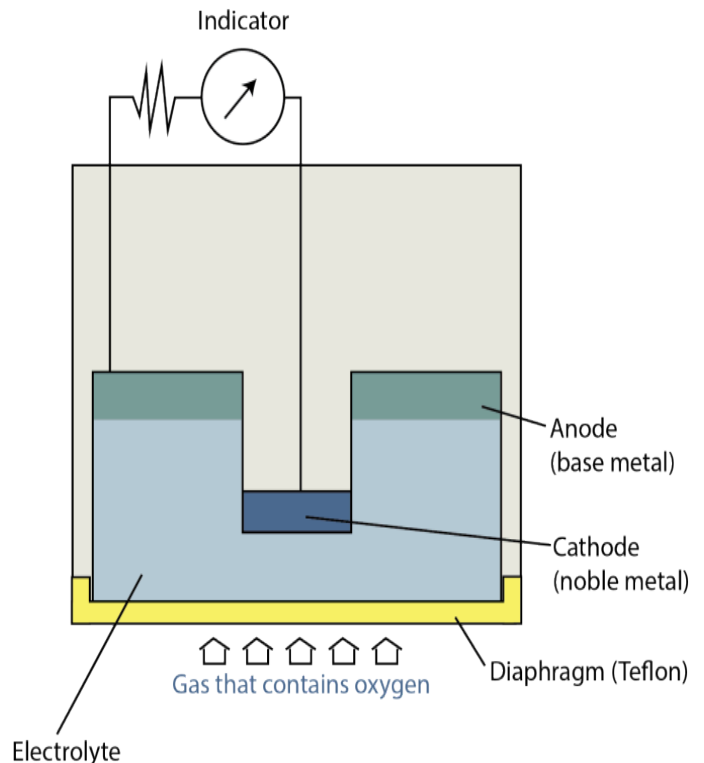

Figure 2.14 Electrochemical measurement principle

**Advantages:**

- The detecting system can be made compact; this measurement system is available in portable or transportable form.
- Relatively inexpensive in comparison with oxygen analyzers of other measurement systems.

**Disadvantages:**

- The cell life is limited. The sensor contains an internal electrolyte solution and evaporation of the water out of the cell makes the sensor nonfunctional. Typical lifetime is 6- 24 months.
- The electrochemical cells are sensitive to temperature, although the effect is relatively small. Changing the temperature from +20 to -20°C will result in approximately a 10% loss of output signal.

**2.5.3 Optical: Tunable Diode Laser Spectroscopy**

Tunable Diode Laser Spectroscopy (or TDLS) measurements are based on absorption spectroscopy. The TruePeak Analyzer is a TDLS system and operates by measuring the amount of laser light that is absorbed (lost) as it travels through the gas being measured. In the simplest form a TDL analyzer consists of a laser that produces infrared light, optical lenses to focus the laser light through the gas to be measured and then on to a detector, the detector, and electronics that control the laser and translate the detector signal into a signal representing the gas concentration.

Gas molecules absorb light at specific colors, called absorption lines. This absorption follows Beers law.

TDLs Analyzers are effectively infrared analyzers which obey the Beer-Lambert Law.

$$I = I_0 \cdot e^{-E \cdot G \cdot L}$$

where I is the radiation intensity after absorption, I<sub>0</sub> is the initial radiation intensity, E is the extinction coefficient, G is the gas concentration, and L is the path length of the measurement area.

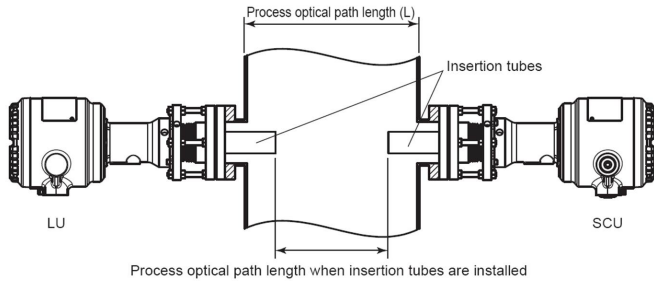

Figure 2.15 Optical measurement principle

*Advantages:*

- Capable of measuring a number of near infrared absorbing gases in difficult process applications.
- Capability of measuring at very high temperature, high pressures and under difficult conditions (corrosive, aggressive, high particulate service).
- Most applications are measured in-situ, reducing installation and maintenance costs.

*Disadvantages:*

- The installation of the flange is necessary for both sides of the process.

**It is important to select the appropriate measurement method for the application. The below table is to be used as a quick reference only.**

Application	Potentiometric ZR Product Series	Potentiometric OX400
Package boilers	A*	X
Combustion control	A	X
Incinerator combustion control	A	X
Lime or Cement kiln combustion control	A*	X
Safety control (explosion prevention) at various plants	X	X
Oxygen concentration control of gas containing a flammable gas	X	X
Low-oxygen concentration	X	A
Oxygen deficiency prevention and Atmospheric control	X	A
Oxygen concentration control of glove boxes	X	A
Naptha cracking furnaces	X	X
N2 and air purity control for air separators	X	A
Continuous measurement of flow gases during food packaging	X	B
Oxygen concentration control of N <sub>2</sub> reflow furnaces	X	A
Humidity in Paper Driers	A	X
Humidifiers	A	X

**Rating:** A = Recommended, B= Applicable, X= Not Applicable  
 \*Depending on the product selection



If the reference gas and process gas are at the same total pressure, the only thing that will contribute to the oxygen partial pressure differential is the concentration of oxygen on the process side.

Standard Zirconia probes are designed to vent the reference gas to atmosphere, which pretty much assures the reference gas is very close to atmospheric pressure (101.4 kPa absolute, 0 kPa gauge). Most of the applications where Zirconia probes are used to measure oxygen are low pressure applications (<4.98 kPa gauge). This means the total pressure of the process gas and reference gas are close, so errors in the measurement are minimal.

It is in higher process pressure applications (>4.98 kPa gauge) that the errors in the measurement can become substantial with non-compensated Zirconia probes. The increase in process pressure increases the partial pressure of oxygen, even though the % concentration of oxygen remains the same. Remember that the analyzer assumes that the only thing that increases the partial pressure of oxygen is an increase in % concentration.

Pressure compensated probes are designed to equilibrate the reference gas pressure with the process gas pressure. To accomplish this, the reference gas is exhausted into the process at a low flow rate of 0.8 LPM. When the total reference gas pressure equals the total process pressure, the only thing that will contribute to the oxygen partial pressure differential is the concentration of oxygen in the process. This system also allows the process pressure to vary, as the reference gas pressure will float with the changes as long as it is flowing.

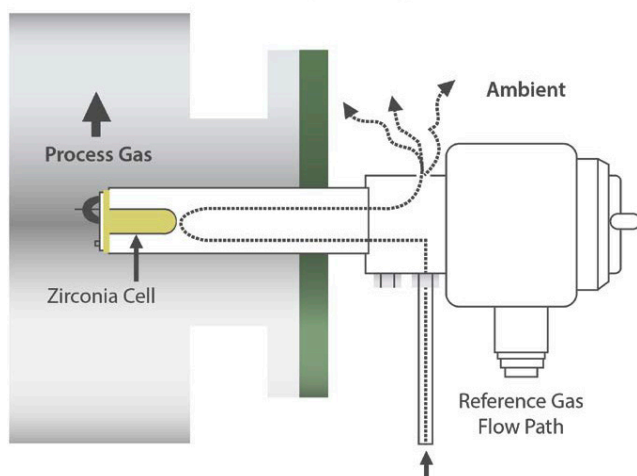

Figure 3.3 Illustration of Standard (un-compensated) probe

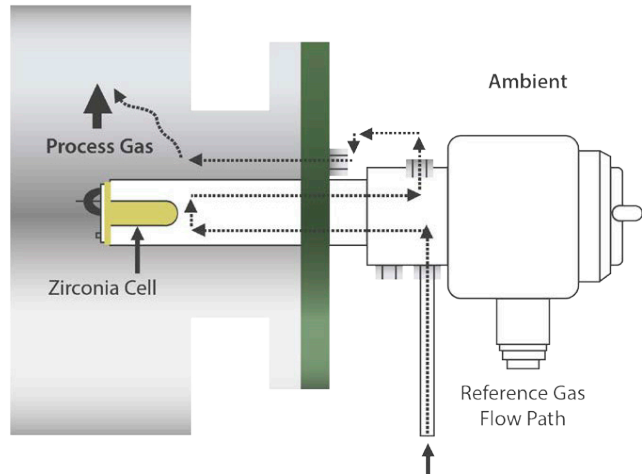

Figure 3.4 Illustration of Pressure Compensation Method

### Considerations

To maintain an accurate measurement, the Pressure Compensated detectors should be considered if the process pressure is greater than 4.98 kPa, and varies widely.

Ensure that your process can withstand having 0.8 LPM of air introduced into it, and that the air can be easily dissipated downstream (no sleeves, protectors or supports that will trap the reference air). Some applications cannot be “contaminated” with reference air. For these applications, one solution is to use a standard (non-compensated) probe, and calibrate the probe in-situ at process pressure. This will “calibrate out” the pressure induced error, but will decrease the usable life span of the cell (cells have a zero point correction up to 30%).

### 3.4 Zirconia Oxygen High Temperature Adapter

The purpose of the High Temperature Adapter (ZO21P or ZR22P) is to accommodate the ZR22 series of Zirconia Oxygen Detectors for use in process gas temperatures that exceed 700°C (1292°F).

The High Temperature Probe Adapter uses either existing process pressure, or vacuum pressure to draw a sample away from the process and cool it to a temperature below 700°C. This allows the Zirconia detector to operate away from the high temperatures where the cell/detector is not designed to work.

Several models of the High Temperature Adapter are available for different applications and environments, and can be selected to accommodate the varying needs of these process samples. When building a model code a few questions need to be considered:

What is the required process flange connection size?

- **What is the temperature of the process?**

The High Temperature Probe Adapter system can accommodate process temperatures of 700°C (1292°F) to 1871°C (3400°F), when using alumina ceramic transport tube. The adapter itself is made of 316 Stainless Steel, but the transport tube (in-situ portion) utilizes different materials based on the temperature ranges of the process gases. Please note that the alumina ceramic is not offered globally, and you should consult your local office for area product offerings.

- **What is the process pressure?**

If the process has a positive pressure the sample gas will naturally be forced up to the oxygen probe. When there is a negative process pressure, the sample will need to be drawn to the oxygen probe. The High Temperature Probe Adapter can be fitted with an air educator (ejector), which creates a vacuum to draw the sample to the probe. Depending upon environmental regulations, the customer may wish to vent the sample gases to atmosphere, or return the sample back into the process. The Eductor (ejector) Return option, pipes the sample gases back through the adapter flange into the process.

- **Is there a high amount of particulate?**

Many processes contain large amounts dust and particulates (i.e. lime kilns), and these particulates can clog the oxygen sampling system. The High Temp Adapter can be provided with an Automatic Blowback system to keep the sampling system open. It is controlled via the ZR402G Converter or the AV550G Averaging system. A 4-way, 2 position single solenoid valve with a double acting air actuator is used to isolate the detector during blowback operation.

- **Where does the sample gas go?**

Occasionally, the ambient conditions outside of the process may lead to a condensation build up within the educator (ejector). The high temp adapter can be provided with a heating option that uses conductive and convective heat from the process gasses to heat the instrument air prior to reaching the educator (ejector). The process gasses are then vented to atmosphere, instead of being piped back into the process.

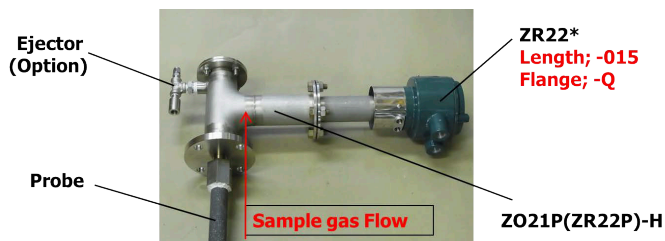

Figure 3.5 High Temperature Probe Adapter

### 3.5 Calibration Equipment

For calibration needs, Yokogawa offers a variety of products from portable calibration units, integrated calibration units, to manual and automatic calibration panels. Not all products mentioned below are offered globally, please consult your local office for area product offerings.

- **The Standard Gas Unit (ZO21S)** is a portable unit for calibration gas supply consisting of span gas (air) pump, zero gas cylinder with sealed inlet, flow rate checker and flow rate needle valve.

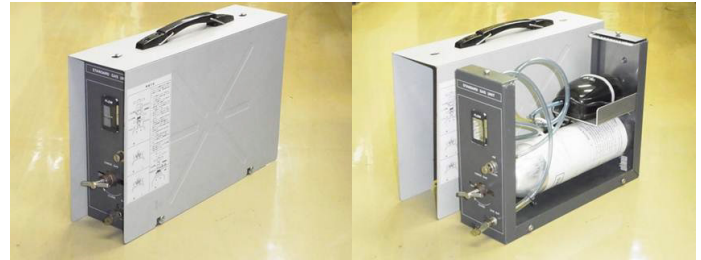

Figure 3.6 ZO21S

- **The Portable Calibration Gas Kit (M1233SR)** is a portable unit for calibration that comes with a 105L zero gas cylinder (1% O<sub>2</sub> with a balance of N<sub>2</sub>) and a 105L span gas cylinder (21% O<sub>2</sub> with a balance of N<sub>2</sub>).
- **The Flow Setting Unit (ZA8F)** consists of a flow meter and flow control valve to control flow rates of calibration gas and reference gas when instrument air is provided



Figure 3.7 ZA8F Flow setting unit

- **The Automatic Calibration Unit (ZR40H)** should be used when automatic calibration is required for the separate type or integrated type and instrument air is provided.



Figure 3.8. ZR40H Auto Calibration unit

- **The Manual Calibration Panel (MC1)** is for a single oxygen probe. It provides regulation of the reference air and calibration gas while allowing the operator to select zero or span gas for calibration. Separate flow meters are used to set calibration gas flow rates and reference air.

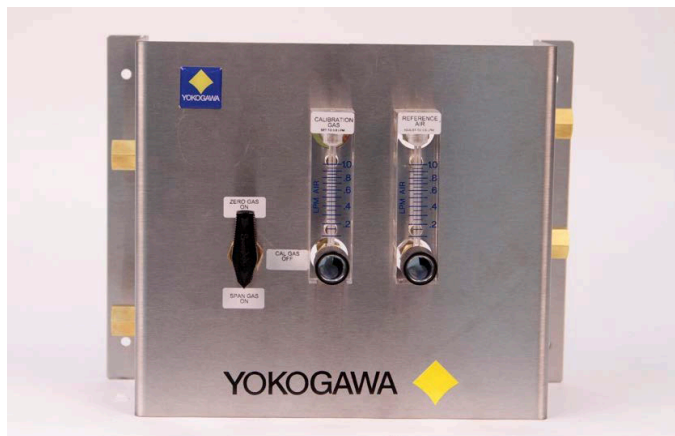

Figure 3.9 Manual Calibration Panel

- **The Automatic Calibration Panel (AC1/AC4/AC8)** is used either with the ZR402 or AV550 converter and allows the user the luxury of setting flow rates and timing sequences. There are three types of automatic calibration units with 1-, 4- and 8- channel capacities for automatic execution of calibration using solenoid(s). Each allows for independent adjustment of flow rates for all reference air and calibration gases with standard manual overrides for each channel.

The AC1 includes individual span, zero and block solenoids with manual overrides for easy setup of flow rates. It also contains a 1 amp fuse with an LED indicator to signal a power surge. The user has a choice of copper or stainless steel tubing in addition to NEMA 4 or NEMA 4X enclosures. The AC1 provides excellent regulation control of reference air and calibration gas flow rates.



Figure 3.10 Automatic Calibration Panel

The model AC4 automatically calibrates up to four oxygen detectors while the model AC8 can calibrate a maximum of eight.

- **The Integrated Automatic Calibration Unit (IAC24)** is an ultra-compact device that mounts directly onto the ZR22G or ZR202G zirconia detector, recommended for indoor installations only. It has no user adjustable parts, is only 4 inches wide and used for single detectors. The unique mounting configuration is designed to minimize installation time. Just connect the calibration and reference gases, set the correct pressure, and the device and analyzer do the rest.



Figure 11. IAC24

- **The Check Valve** prevents water vapor in the process from diffusing down the calibration line where it may condense and cause the cell to crack. A check valve should be used on all natural gas and positive pressure applications and any time a calibration line is installed with long periods (>3 months) of time between calibrations.

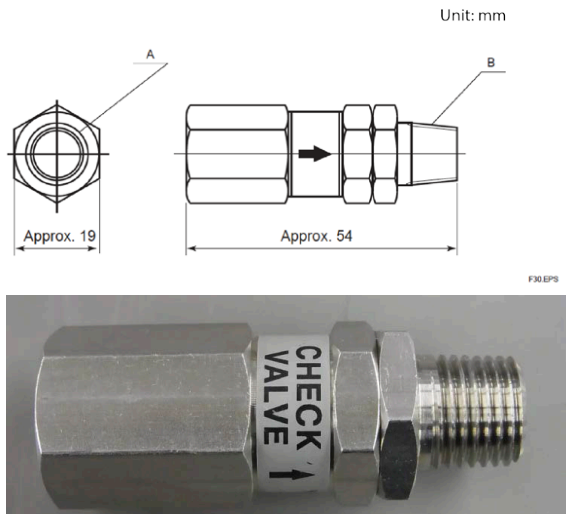

Figure 3.12 Check Valve Design

### 3.6 Filters and Accessories

Many industries use a variety of fuel sources to fire their processes, including natural gas, coal, oil, trash and waste (also known as biomass). Coal and biomass fuels release a significant amount of carbon particulate when burned, known as fly ash. This fly-ash can clog the Zirconia cell, resulting in slow or no response to changes in the oxygen concentration. Depending on your region Yokogawa offers various filters to assist in the prevention of clogging.

- **The Self Cleaning Fly-Ash Filter (M1234SE-A)** is a sintered filter that incorporates an aerodynamic shield that deflects the particles, and prevents fly-ash build up from clogging the ZR22 Oxygen Probe. This filter should be used whenever coal or biomass is the primary fuel source.

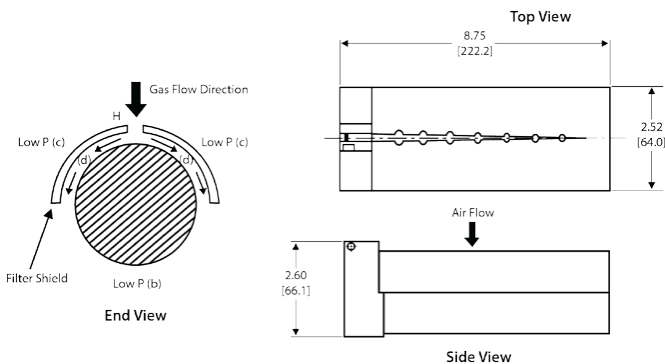

Figure 3.13 M1234SE-A Filter Design

- Filter Material: Hastelloy X
- Base Material: 316 SS
- Max. O.D.: 6.35cm (2.5in)
- Max Operating temp: 700°C (1292°F)
- Pore size: 10 micron

- **The Hastelloy X Sintered Filter (M1200DB-06)** is a sintered filter that addresses blockage and coating problems experienced by tough applications that are more stagnate.

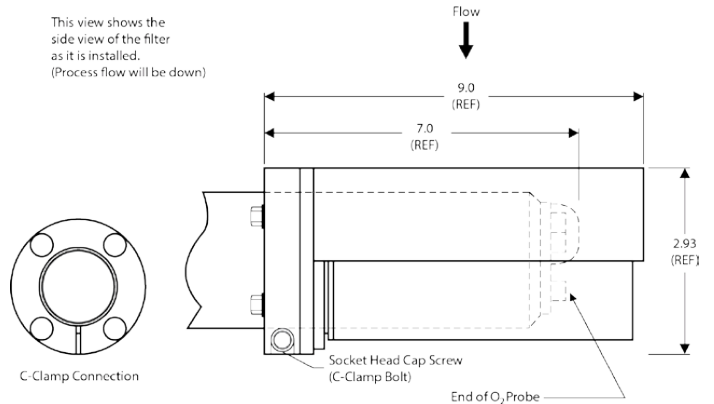

Figure 3.14 M1200DB-06 Filter Design

- **The Dust and Oil Filter (E7042UQ)** attaches to the end of the ZR22 Oxygen Probe, and is used for oil fired applications as well as black liquor recovery systems. The Filter utilizes a Silicon Carbide (SiC) filter disc enclosed in a 316SUS cylinder. Once installed the filter will have the same outside diameter as the ZR22 Oxygen Probe (as shown).



Figure 3.15 E7042UQ Filter Design

- **The Dust Filter (K9471UA)** is used to protect the cell from corrosive dust components or high velocity dust in recovery boilers and cement kiln. Sample gas flow rate must be 1m/sec or more to replace gas inside zirconia sensor.



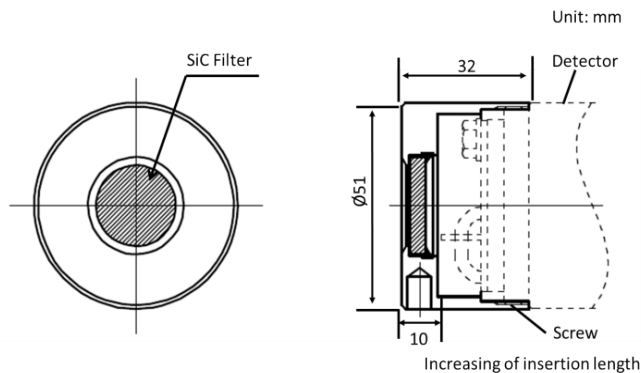

Figure 3.16 K9471UA Filter Design

- **The Dust Guard Protector (K9471UC)** is recommended when sample the gas is likely to flow directly into the cell due to the detectors position in the stack where flammable dust or water drops may go into the cell.

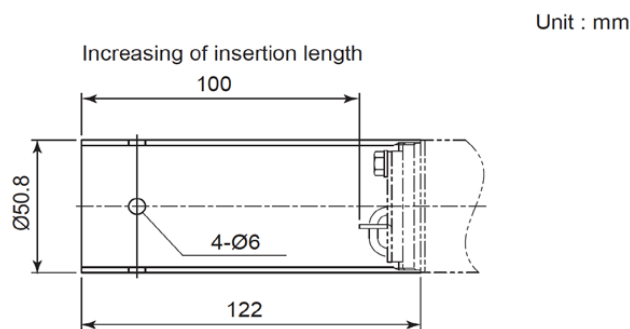
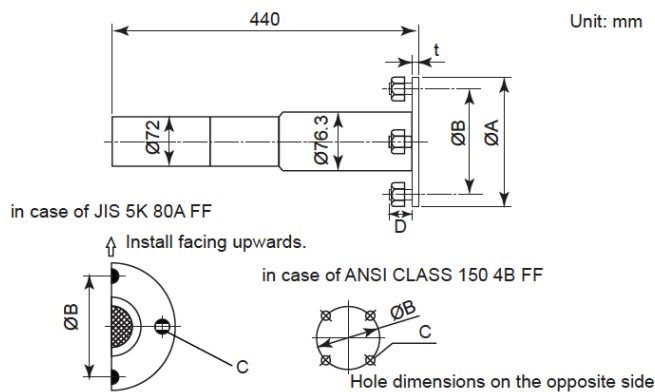

Figure 3.17 K9174UC Filter Design

- **The Dust Protector (ZH21B)** is used for high temperature humidity applications such as paper dryers. This protector is designed to protect the probe output from dust agitation (i.e., to prevent combustible materials from entering the probe cell) where humidity measurements are made under dusty environments.



Flange	A	B	C	t	D
JIS 5K 80 FF SUS304 (JIS)	180	145	4-Ø19	14	40
ANSI Class 150 4B FF SUS304 (JIS)	228.5	190.5	8-Ø19	12	50

Figure 3.18 ZH21B Filter Design

- **The Eductors (Ejector)** are used in high temperature installations where negative pressure is present. Using instrument air, the eductor (ejector) draws a sample through the adapter tee for quick measurement without mechanical assistance. Different models are available in the different regions.

Note: Positive pressure requires the use of a needle valve to restrict the flow of sample gas.

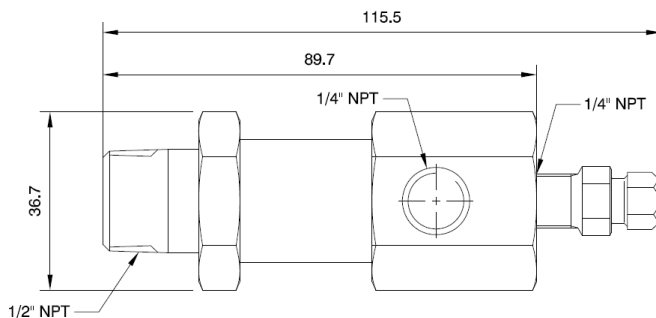

Figure 3.19 One example of an eductor (ejector) Design

### 3.7 Probe Protectors and Probe Supports

**Probe protector (ZO21R or ZR22R)** is used when the sample gas flow velocity is approx. 10m/sec (33ft/sec) or more and dust particles may be present that can wear away the detector, such as a pulverized coal boiler or fluidized bed furnace (or burner). The probe protector is a stainless steel tube attached to a flange that provides full length protection for the ZR22 oxygen probe. A probe protector should also be used when a probe insertion length is 2.5 m or more and in horizontal installation.

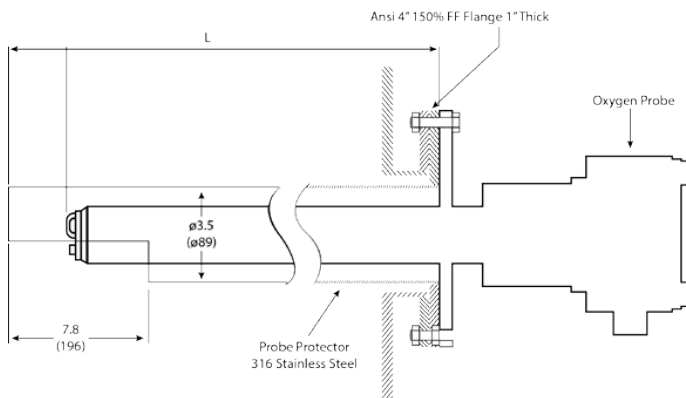

Figure 3.20 ZO21R/ZR22R Design

**Probe support (ZR22V)** is not available in all regions, but it is used for natural gas applications where there is no particulate but is used to provide additional structural support for probe over 3 meters in length when installed in horizontal orientation.

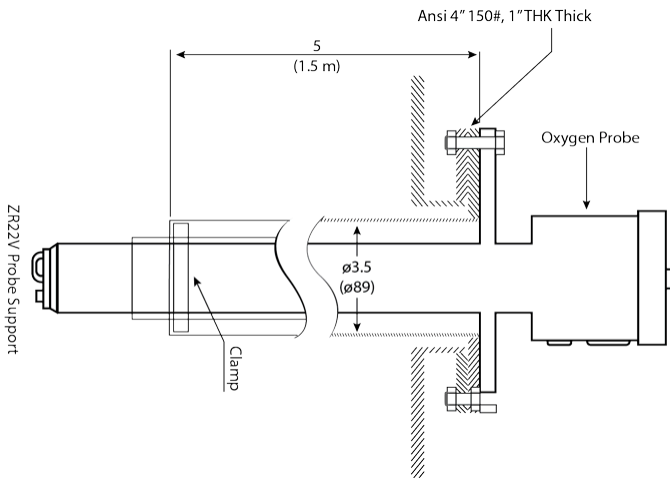

Figure 3.21 ZR22V Design

### 3.8 Zirconia Oxygen Single Unit Analyzer, Model ZR402G

The EXAxt Zircon Oxygen Analyzer (Model ZR402G) is used to monitor and control the oxygen concentration in combustion gases, in boilers and industrial furnaces, for wide application in industries which consume considerable energy—such as steel, electric power, oil and petrochemical, ceramics, paper and pulp, food, or textiles, as well as incinerators and medium/small boilers. It can help conserve energy in these industries.



Figure 3.22 Model ZR402G

The ZR402G offers the following features:

- Liquid-crystal touch panel display provides easy operation
- Back-lit LCD allows viewing even in the darkness
- Interactive model displays instructions to follow, including those for: settings, oxygen concentration trends, and calibration operations
- Error codes and details of errors can be checked in the field without the need to refer to the appropriate instruction manual
- Digital communications features are provided as standard – this enables the analyzer to be maintenance-serviced remotely

- Can measure either oxygen concentration or humidity with a single analyzer
- Highly reliable measurements with trend-data graphs
- Contact input allows calibration activation, range change and detector performance validation

### 3.9 Zirconia Oxygen Multi Unit Averaging Analyzer, Model AV550G

The O2mation, model AV550, averaging oxygen analyzer was designed with a focus on practical performance. Yokogawa has refined its expertise in the combustion oxygen business into this new and creative product. It is packed with features designed to minimize plant down time and technical support for the oxygen measurement.

Its intuitive color touch screen operation, powerful new process diagnostic tools and creative hardware design makes power boiler oxygen trim automation simple, predictable and reliable. The trend graph helps diagnose problems and view individual detector performance over time. Maintenance and inspection are simplified by a modular hardware design. The Hot Swap feature allows changing channel modules without powering off the analyzer. Each channel card is fitted with spacious, and accessible, self-trapping terminal strips that make wiring and maintenance fast and easy.



Figure 3.23 Model AV550 Averaging Converter

The AV550G offers the following features:

- Full Color Liquid-crystal touch panel display
- Back-lit LCD allows viewing even in the darkness
- Handles input of up to 8 oxygen detectors
- Interactive model displays instructions to follow, including those for: settings, oxygen concentration trends, and calibration operations
- Error codes and details of errors can be checked in the field without the need to refer to the appropriate instruction manual
- Multiple display modes shows average, single or all detector gas concentrations
- Redundant channel systems using multiple CPUs

- Can measure either oxygen concentration or humidity with a single analyzer
- Highly reliable measurements with trend-data graphs
- “Hot swap” of channel cards so the analyzer remains on line during maintenance
- Eight 4-20mA outputs for individual detectors
- Three 4-20mA outputs for average oxygen concentration outputs
- Failed, in calibration, or alarming, detectors are automatically excluded from average calculations
- Automatic or manual type calibration methods
- 24V or 120VAC auto-calibration power option
- Contact input allows calibration activation, range change and detector performance validation
- Intuitive “common language” operation
- Housing temperature alarm to notify user of over temperature conditions on the electronics

### 3.10 Integral Type Zirconia Oxygen Detector and Analyzer, Model ZR202

The EXAxt ZR Integrated type Zirconia Oxygen Analyzer (ZR202) integrates both probe and converter into one installed instrument. There is model ZR202G for general purpose and model ZR202S for explosion proof for hazardous applications. The analyzer does not need a sampling device, and it allows for direct installation of the probe in the wall of a flue or furnace to measure the concentration of oxygen in the stack gas of the temperature up to 700°C. The probe uses a high-reliability Zirconia sensor (E7042UD) and a heater assembly that can be replaced on site.

The analyzer is equipped with three infrared switches, which enable the user to operate the equipment without opening the cover on site. Analyzer calibration can also be fully automated and the automatic calibration unit is provided. Choose the equipment which best suits your needs so that an optimal combustion control system can be obtained.



Figure 3.24 ZR202 Series Integral Detector and Analyzer

The ZR202 offers the following features:

- For the Zirconia cell, which is a key component of zirconia oxygen analyzers, a zirconia element and platinum electrodes are molecularly bonded by a method developed by Yokogawa. Therefore, the zirconia sensor can deliver consistent measurements for a long period without the electrode being peeled off.

- The sensor (zirconia cell) can be easily replaced by simply removing four bolts. The filter attached at the front of the sensor is a large-mesh wire net that prevents large dust particles from entering the sensor.
- The heater assembly used to heat up the zirconia cell is constructed so that it can be replaced in the field. Even if a wire in the heater breaks, the heater can be easily replaced in the field.
- Can cut wiring, piping and installation costs
- Can be operated in the field without opening the cover using an infrared switch
- Can measure either oxygen concentration or humidity with a single analyzer
- Remote maintenance using digital communication reduces maintenance cost

### 3.11 Zirconia Oxygen Low Concentration Analyzer, Model OX400

The OX400 is an accurate and reliable low-concentration zirconia oxygen analyzer capable of measuring O<sub>2</sub> concentrations, from 0-10 ppm up to 0-100 vol% O<sub>2</sub>. This is the latest oxygen analyzer from Yokogawa, and its development was based on the company’s long experience and strong track record with this technology.

A proprietary new thin-film deposition technology was used in the zirconia sensor that creates a molecular bond between the zirconia element and the platinum layer. This prevents separation, enables a reduction in sensor size and ensures a high-speed response and long life.

The OX400 can be used to control and monitor various semiconductor applications, and to control environment, air leakage into inert gas, and other processes.



Figure 3.25 Low Concentration Oxygen Analyzer

The OX400 offers the following features:

- Long life and high-speed response thanks to the use of Yokogawa’s proprietary new thin-film deposition technology, the sensor has three times the lifespan of those used in our earlier products.

- A cylindrical sensor design facilitates the replacement of measurement gases, thereby helping to assure a high-speed response.
- Either pump or aspirator sampling can be selected, depending on the application
- Built-in functions and a variety of self-diagnosis functions
- Comes with multi selector, auto range, partial range, and pump on/off functions
- A variety of self-diagnosis functions are provided that detect malfunctions such as heater temperature error, temperature sensor burnout, and sensor resistance value error.
- The sensor can be replaced on-site.
- Compact and lightweight for easy installation.

### 3.12 Limiting Current Type Oxygen Analyzer

#### 3.12.1 Model OX100

The OX100 Oxygen Analyzer measures oxygen concentration from ppm to percent levels and is ideal for ppm-level measurements in such applications as nitrogen reflow furnaces and semiconductor plants. The zirconia oxygen sensor is based on the limiting current principle and is compact, yet provides high-performance. The sensor is designed for installation by direct insertion. Where a sample gas contains organic solvent at a few ppm to percent level in applications such as nitrogen reflow furnaces, an optional sampling unit is required.



Figure 3.26 Low Concentration Oxygen Analyzer

The OX100 offers the following features:

- A single instrument capable of measuring 1000ppm to 25% oxygen
- Simple one touch calibration
- Self-diagnostics assure high reliability
- “One touch” sensor replacement
- Compact size

#### 3.12.2 Model OX102

The OX102 Oxygen Analyzer measures oxygen concentration from ppm to percent levels in a single analyzer and is ideal for ppm-level measurements in applications such as nitrogen reflow furnaces and semiconductor plants.

The zirconia oxygen sensor uses a method that is based on the limiting current principle and is compact, yet has high-performance. The sensor is designed for installation by direct insertion.

When a sample gas contains organic solvent at a few ppm to percent level in applications such as nitrogen reflow furnaces, an optional sampling unit is required.



Figure 3.27 Low Concentration Oxygen Analyzer

The OX102 offers the following features:

- A single instrument capable of measuring 100 ppm to 25% oxygen
- Simple one touch calibration
- Self-diagnostics assure high reliability
- “One touch” sensor replacement
- Compact size

***It is important to select the appropriate product for the application. The below tables are to be used as a quick reference of the different products available and their specifications. Table 2 is also included to assist when you will select an OX400 over an OX100/OX102.***

**Table 1: Quick Reference Model Specifications**

Measuring System	Zirconia				
Model	ZR22*, ZR402G	ZR202*	ZR22*, AV550G	OX400	OX100/OX102
Min. Measuring Range	0-5 Vol% O <sub>2</sub>	0-5 Vol% O <sub>2</sub>	0-5 Vol% O <sub>2</sub>	0-10 ppm O <sub>2</sub>	0-1000 ppm O <sub>2</sub> / 0-100 ppm O <sub>2</sub>
Max. Measuring Range	0-100 vol% O <sub>2</sub>	0-100 vol% O <sub>2</sub>	0-100 vol% O <sub>2</sub>	0-100 vol% O <sub>2</sub>	0-25 vol% O <sub>2</sub>
Measuring Range Setting	Settable arbitrarily within the range (in vol% O <sub>2</sub> units)			Auto/Man.	Fixed 2 ranges/ 0-100 ppm O <sub>2</sub>
Partial Range	Available	Available	Available	Available	Not Available
Output Signal	4-20 mA DC HART	4-20 mA DC HART	4-20 mA DC 8 points Fieldbus	4-20 mA DC and 0-1, 5, 10 V DC (selectable)	4-20 mA DC or 1-5 V DC/ 4-20 mA DC
Sample Gas Temperature	0-1400°C	0-700°C	0-1400°C	0-50°C	0-70°C
Sample Gas Pressure	-5-250 kPa	-5-250 kPa	-5-250 kPa	0-300 Pa	1013±40 hPa Abs
Response Time (90%) (When gas is introduced from the detector inlet)	5 sec or less	5 sec or less	5 sec or less	10 sec or less (1% O <sub>2</sub> or more) 30 sec or less (less than 1% O <sub>2</sub> )	
Warm-up time	20 min	20 min	20 min	20 min or less	
Explosion proof Construction	Option Available	Option Available	Option Available	Non-Explosion proof protected	Non-Explosion proof protected
Application Form	Stationary	Stationary	Stationary	Stationary/ Transportable	Stationary
Separately Installed Sample System	Not Required	Not Required	Not Required	May be required depending on applications	

**Table 2: When to quote OX400 instead of OX100/OX102**

Measuring System	Zirconia	Limiting Current
Model	OX400	OX100/OX102
Min. measuring range	0 – 10 ppm O <sub>2</sub>	0 – 1000 ppm O <sub>2</sub> /0 – 100 ppm O <sub>2</sub>
Measuring range setting	Auto/Man.	Fixed to 2 ranges/0 – 100 ppm O <sub>2</sub>
Partial range	Available	Not Available
Output signal	4 – 20 mA DC and 0-1, 5, 10 V DC (selectable)	4 – 20 mA DC or 1 – 5 V DC/4 – 20 mA DC
Sample gas temperature	0 – 50°C	0 – 70°C
Sample gas pressure	0 – 300 Pa	1013±40 hPa Abs
Response time (90%) (When gas is introduced from the detector inlet)	10 sec or less (1% O <sub>2</sub> or more) 30 sec or less (less than 1% O <sub>2</sub> )	
Warm-up time	20 mins or less	3 mins
Oxygen concentration control of N2 reflow furnaces	A	B/A
Atmospheric control of semiconductor manufacturing equipment	A	B/A
N2 and air purity control for air separators	A	B/A
Oxygen deficiency prevention	X	A
Oxygen concentration control of glove boxes for research and development and parts machining	A	B/A
Oxygen concentration control of experimental clean rooms for environment, fermentation, biochemistry, etc.	B	A
Continuous measurement of flow gases during food packaging	B	A

Rating: A=Recommended, B=Applicable, X=Not Applicable

## 4. Application Notes

This section takes up typical application examples for the zirconia oxygen analyzer. These individual applications are structured as follows.

Application examples: Overview of individual devices, and sample points.

Sample gas condition examples: Examples of sample gas conditions, and block diagrams and type numbers for zirconia oxygen analyzer systems to be used under those conditions.

**Table 4.1 Oxygen Measurement**

Industry	Application	Benefits	Model	Remarks	Location	Reference
Power	Excess Air				Boilers (Natural gas, furnace oil fuelled) Boilers (Coal Fuelled)	Ref section <b>b</b> of BOILER application in TI 11M12A01-01E
Power	Oxygen concentration in exhaust gases from pulverized coal power boilers	Improves combustion efficiency	Detector: ZR22G Probe protector: ZO21R/ ZR22R Converter: ZR402G Manual calibration unit: ZA8F/MC1 Calibration gas unit Pressure regulator for gas cylinder: <ul style="list-style-type: none"> <li>P/N G7013XF (inlet W22, outlet Rc1/4) or P/N G7014XF (inlet W22, outlet 1/4NPT)/M1132ZX</li> <li>Case assembly for calibration gas cylinder: P/N E7044KF</li> </ul> Note: the calibration gas cylinder must be purchased locally	Temperature: 300 to 400°C Flow rate: ≤ 30 m/s Pressure: ±1.5 kPa Dust concentration: approx. 15 g/Nm <sup>3</sup> or less  A probe protector should be attached to the probe for protection against wear or damage. The probe protector should be mounted with the notch of the probe head pointing downstream in the gas flow	Economizer outlet	AN 10M01P01-03E  Ref section c of BOILER application in TI 11M12A01-01E
Power	Oxygen concentration in package Boiler Flue gas	Increases Combustion efficiency	Detector: ZR22G Converter: ZR402G Manual calibration unit: ZA8F/MC1 Options Dust guard protector: P/N K9471UC/M1234SE-A	Temperature: 150 to 300°C Flow velocity: 15 m/s max. Pressure: ±0.5 kPa Dust: 1 g/Nm <sup>3</sup> max.	Boiler & Economizer outlet	AN 10M01P01-02E Ref section a of BOILER application in TI 11M12A01-01E
Refinery	Excess Air				Fired Heaters, Incinerators, Fluidized Catalytic crackers regeneration, Cracking Furnaces	Ref section <b>a</b> & <b>b</b> of P.etroleum Refining & Petrochemical Fired Heaters application in TI 11M12A01-01E

Iron & Steel	Air leak detection in sintering furnaces  Oxygen measurement in Boilers	Efficiency improvement  Quality improvement of sintered ore	Detector: ZR22G/C/CV Probe protector: ZO21R/ ZR22R Converter: ZR402G Automatic calibration unit: ZR40H/AC1/IAC24	Large dust & High Humidity Process  Check for probe protector orientation against the gas flow	Wind box, Boiler	AN 10M01F01-01E
Iron & Steel	Monitoring of oxygen concentrations in steel mill reheating furnaces	Maintains high product quality by monitoring oxygen in steel mill reheating furnaces  Ensures stable continuous measurement of oxygen concentrations  Reduces operating costs	Detector: ZR22G-015-S-Q-.../ CV High temperature probe adapter ZO21P/ZR22P Auxiliary ejector for high temperature use P/N E7046E□□/M1132KE Converter: ZR402G Manual calibration unit: ZA8F/MC1 Calibration gas unit Pressure regulator for gas cylinder: <ul style="list-style-type: none"> <li>P/N G7013XF (inlet W22, outlet Rc1/4) or P/N G7014XF (inlet W22, outlet 1/4NPT)/M1132ZX</li> <li>Case assembly for calibration gas cylinder: P/N E7044KF</li> </ul> Note: the calibration gas cylinder must be purchased locally	Temperature: 900 to 1400°C Pressure: 30 to 50 kPa Dust: Trace Fuel: Gas  When the probe is installed horizontally, bracings must be provided for mechanical support.	Furnace reheat, heat, and soak zones	AN 10M01F01-03E Ref section a of Iron & Steel Mills application in TI 11M12A01-01E
Iron & Steel	Oxygen concentration in Hot Blast Stoves	Improves combustion efficiency	Detector: ZR22G-015-S-Q-.../ CV/Z Z: Glove box option Converter: ZR402G Manual calibration unit: ZA8F/MC1 Calibration gas unit Pressure regulator for gas cylinder: P/N G7013XF (inlet W22, outlet Rc1/4) or P/N G7014XF (inlet W22, outlet 1/4NPT)/ M1132ZX Case assembly for calibration gas cylinder: P/N E7044KF Note: the calibration gas cylinder must be purchased locally	Temperature: 20 to 350°C  Pressure: 3.5 to 10 kPa  Dust: 50 mg/Nm <sup>3</sup>  Fuel: Gas	Duct	AN 10M01F01-02E
Pulp & Paper	Excess Air/ Air Demand		Detector: ZR22G/CV Probe protector: ZO21R/ ZR22R Converter: ZR402G Manual calibration unit: ZA8F/MC1 Calibration gas unit Pressure regulator for gas cylinder: P/N G7013XF (inlet W22, outlet Rc1/4) or P/N G7014XF (inlet W22, outlet 1/4NPT)/ M1132ZX Case assembly for calibration gas cylinder: P/N E7044KF Note: the calibration gas cylinder must be purchased locally	Temperature : 150 to 500°C	Black Liquor Recovery Boilers	Ref section <b>d</b> of BOILER application in TI 11M12A01-01E



Cement		Indication of Calcining rate, Nox production, Increases product quality			Rotating Cement Kiln, Flue gas exit from the Kiln	Ref section <b>a</b> & <b>b</b> of Ceramic, Brick, Glass & Kiln application in TI 11M12A01-01E
Electrical & Electronics	Humidity measurement in Tantalum Capacitor Pyrolysis Furnaces	Ensures product quality & yield improvement, stable continuous humidity measurements in high temperature environment, Reduces operating costs	Detector: ZR22G/SV Converter: ZR402G/HS Portable calibration unit: ZO21S/M1233SR	Temperature: 200 to 400°C  Pressure: 10 to 20 Pa  Humidity: 25 to 80 vol% H <sub>2</sub> O	Inside the steam pyrolysis furnace	AN 10M01N01-01E
Pulp & Paper	Humidity measurement for paper dryer control	Increases dryer heat energy efficiency, ensures high paper quality & reduces operating costs	Detector: ZR22G Dust protector: ZH21/M12345E-A Converter: ZR402G Manual calibration unit: ZA8F/Z Z: with dehumidifier (when needed) /MC1 Pressure regulator for gas cylinder: P/N G7013XF (inlet W22, outlet Rc1/4) or P/N G7014XF (inlet W22, outlet 1/4NPT)/M1132ZX Case assembly for calibration gas cylinder: P/N E7044KF  Note: the calibration gas cylinder must be purchased locally	Temperature: 50 to 120°C  Pressure: Negative Dust: Trace amounts (paper dust), clean dry air should be used for reference air, dust protector to be used to prevent ignition due to paper dust	In the Hood or the exhaust duct of the Hood	AN 10M01J01-01E
Chemical	Humidity measurement in dyeing & discharge process	Ensures stable product quality, stable continuous humidity measurements in high temperature environment, Reduces operating costs	Detector: ZR22G/SV  Converter: ZR402G  Portable Calibration unit: ZO21S/M1233SR	Sample gas component: Steam: 90 to 100%; air: remaining  Temperature: 70 to 110°C  Pressure: 10 to 30 kPa	Steamer	AN 10M01E01-01E

## 4.1 Boiler

### 4.1.1 Package boiler

This is the most common application. Although the system is generally used for combustion monitoring, there are also cases in which it will be used for VVVF or other such combustion control schemes.

Sample point	Sample type	Detector	Objective
Boiler furnace outlet or economizer outlet	L1, (L2)	D1, (D2)	Combustion monitoring

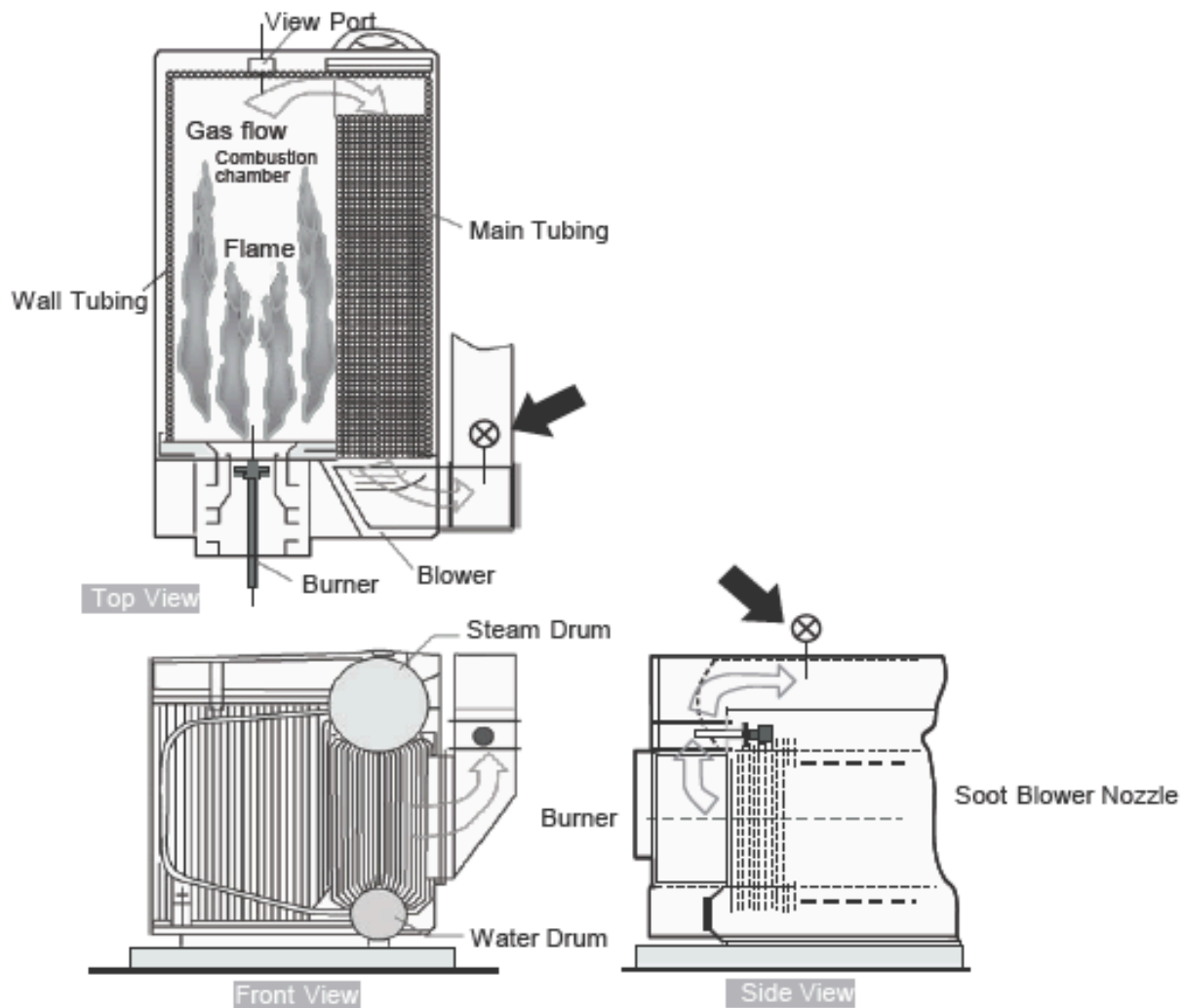

Gas temperature: 150 to 300°C  
 Gas pressure:  $\pm 0.5$  kPa  
 Dust:  $\approx 1$  g/Nm<sup>3</sup>  
 Fuel: Fuel oil, kerosene, or gas

#### 4.1.2 Power generation boiler (Heavy oil, Gas)

This is a large-scale facility in which use for combustion control is more common than for combustion monitoring.

In cogeneration, the majority of cases involve measurement at a single point. In electric power companies, measurements are performed at multiple points in a single flue.

Sample point	Sample type	Detector	Objective
Boiler furnace outlet or economizer outlet	L2, L3	D1, (D2)	Combustion monitoring O <sub>2</sub> control

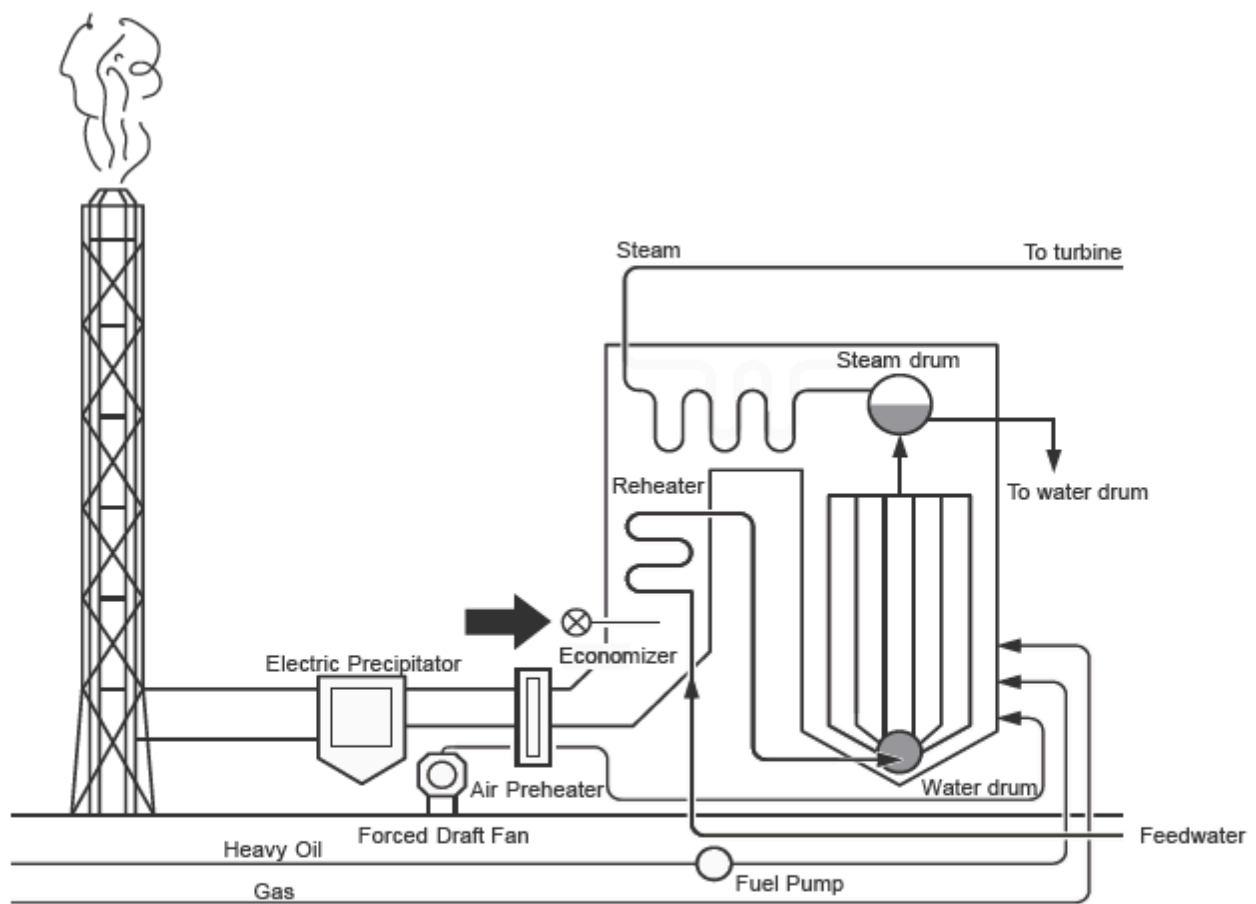

Gas temperature: 250 to 350°C  
 Gas pressure: -0.1 to -0.8 kPa  
 Dust: Approximately 1 g/Nm<sup>3</sup>  
 Fuel: Heavy oil (crude), gas

### 4.1.3 Pulverized coal boiler

These are almost always large facilities such as power generation boilers; the zirconia oxygen analyzer is used for combustion monitoring and combustion control. Since the exhaust gas entrains a rather large amount of ash dust, a detector with dust protector will be used.

Sample point	Sample type	Detector	Objective
Economizer outlet (economizer, feedwater afterheater)	L2, L3 (detector with probe protector)	D4	Combustion monitoring O <sub>2</sub> control

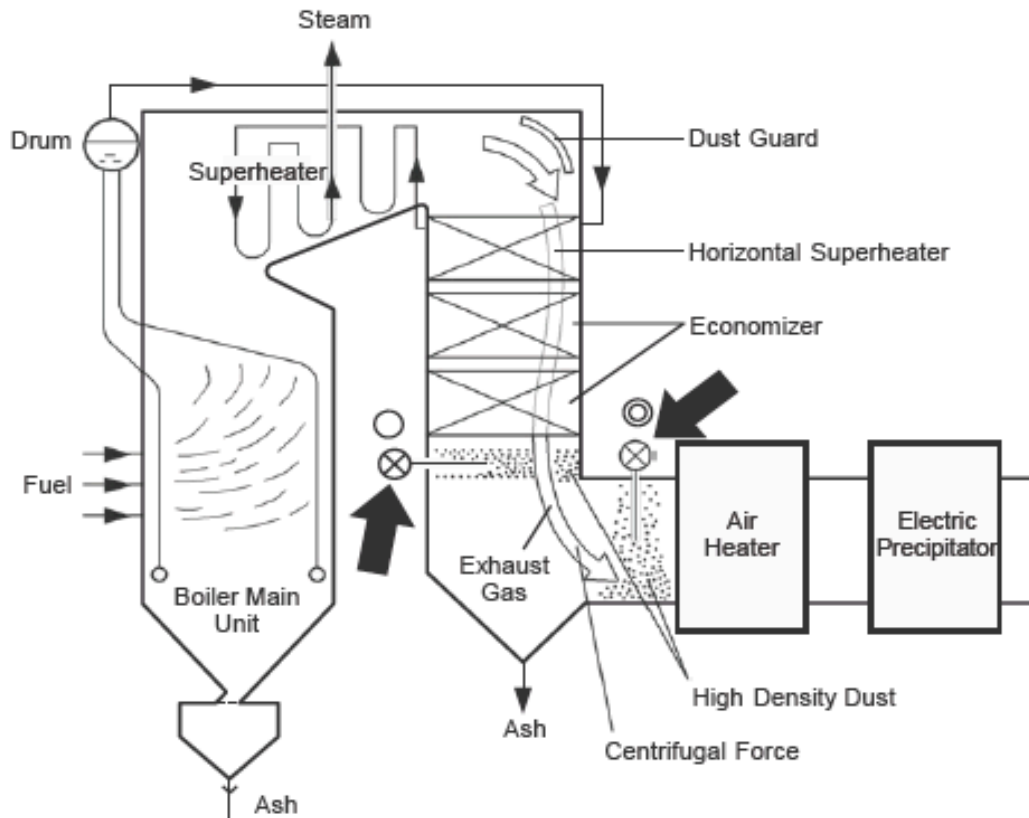

Dust Flow Direction

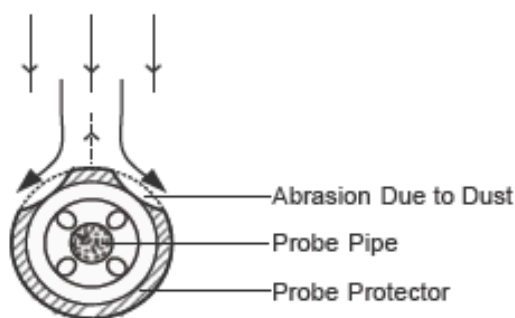

- ⊙: Optimum mounting position
- : Second best mounting position

Gas temperature: 300 to 400°C  
 Gas pressure: -1.5 to +1.5 kPa  
 Dust: Approximately 15 g/Nm<sup>3</sup>  
 Fuel: Pulverized coal

#### 4.1.4 Black liquor recovery boiler

The spent liquor in a pulp production process is commonly referred to as “black liquor”. The sodium carbonate and sulfate components in this black liquor are recovered by burning it and using the heat to generate steam. The oxygen analyzer is used to monitor or control the combustion in the combustion facility (boiler). Since the exhaust gas includes large amounts of dust (hydrated sodium sulfate) and water vapor, a detector with filter is selected.

Sample point	Sample type	Detector	Objective
Economizer outlet (economizer, feedwater preheater)	L2, L3 (detector with filter)	D3, (D4)	Combustion monitoring

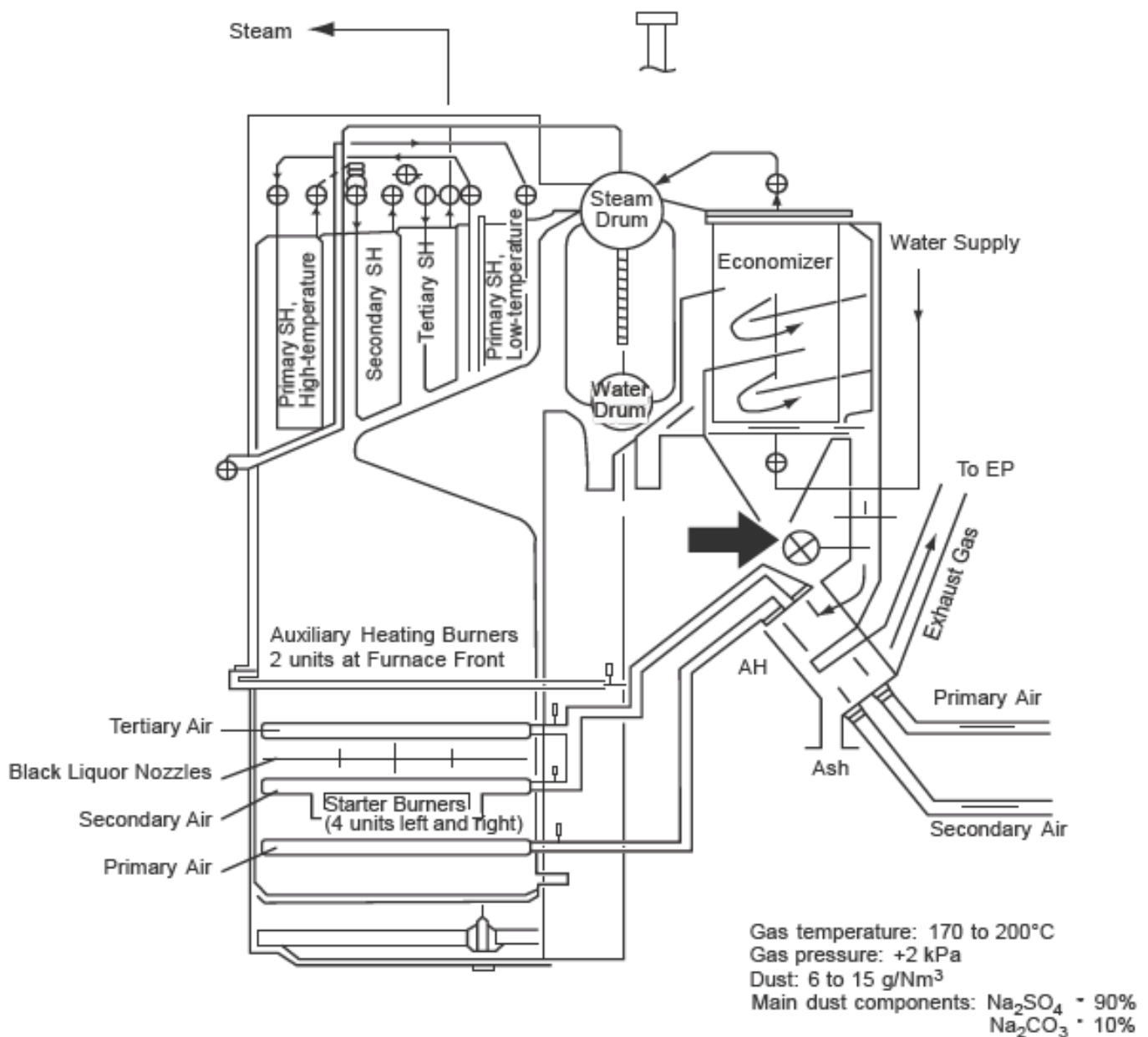

## 4.2 Iron and Steel Furnaces

### 4.2.1 Iron & steel heating furnace

These furnaces are for the heating of steel slabs, and generally the measured gas is at a high temperature of 1000°C or above. The oxygen concentration is controlled to a low level to prevent oxidation of the slabs. These are also some cases in which there is some amount of CO in the gas, and in which magnetic oxygen analyzers or infrared type CO analyzers are used.

Sample point	Sample type	Detector	Objective
Preheat zone, heating zone, soaking zone	H2, H3	D5	Combustion monitoring

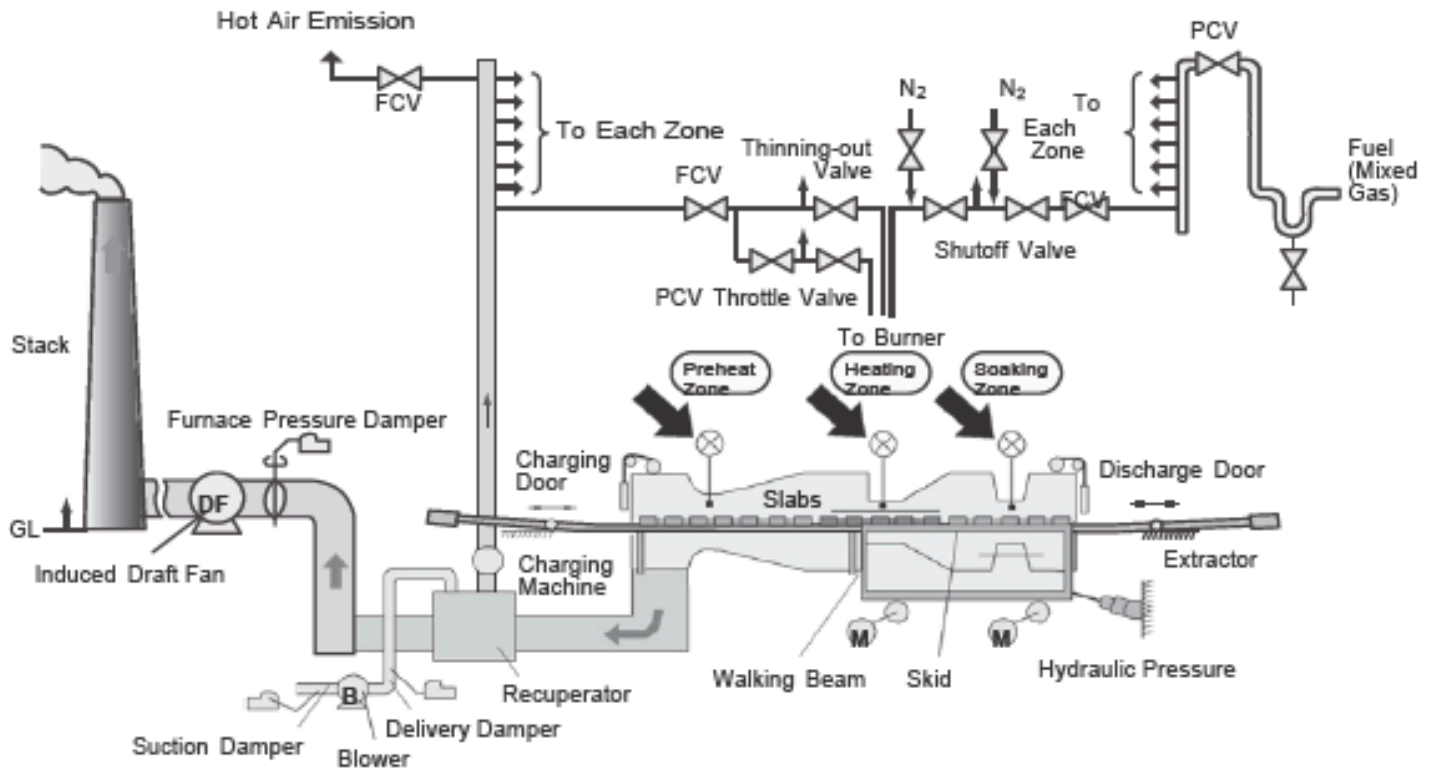

Gas temperature: 900 to 1400°C  
 Gas pressure: 0.03 to 0.05 kPa  
 Dust: Minute  
 Fuel: Gas

#### 4.2.2 Hot blast stove (blast furnace facility)

The hot blast stove is a facility used to heat the air used in a blast furnace to provide the high temperature hot air blast.

The air is heated by combustion of the gas generated from the coke ovens. The zirconia oxygen analyzer is used to control or monitor this combustion.

Sample point	Sample type	Detector	Objective
Duct	L2, L3 (If pressure is high, a pressure compensated detector is selected.)	D1	Combustion monitoring O <sub>2</sub> control

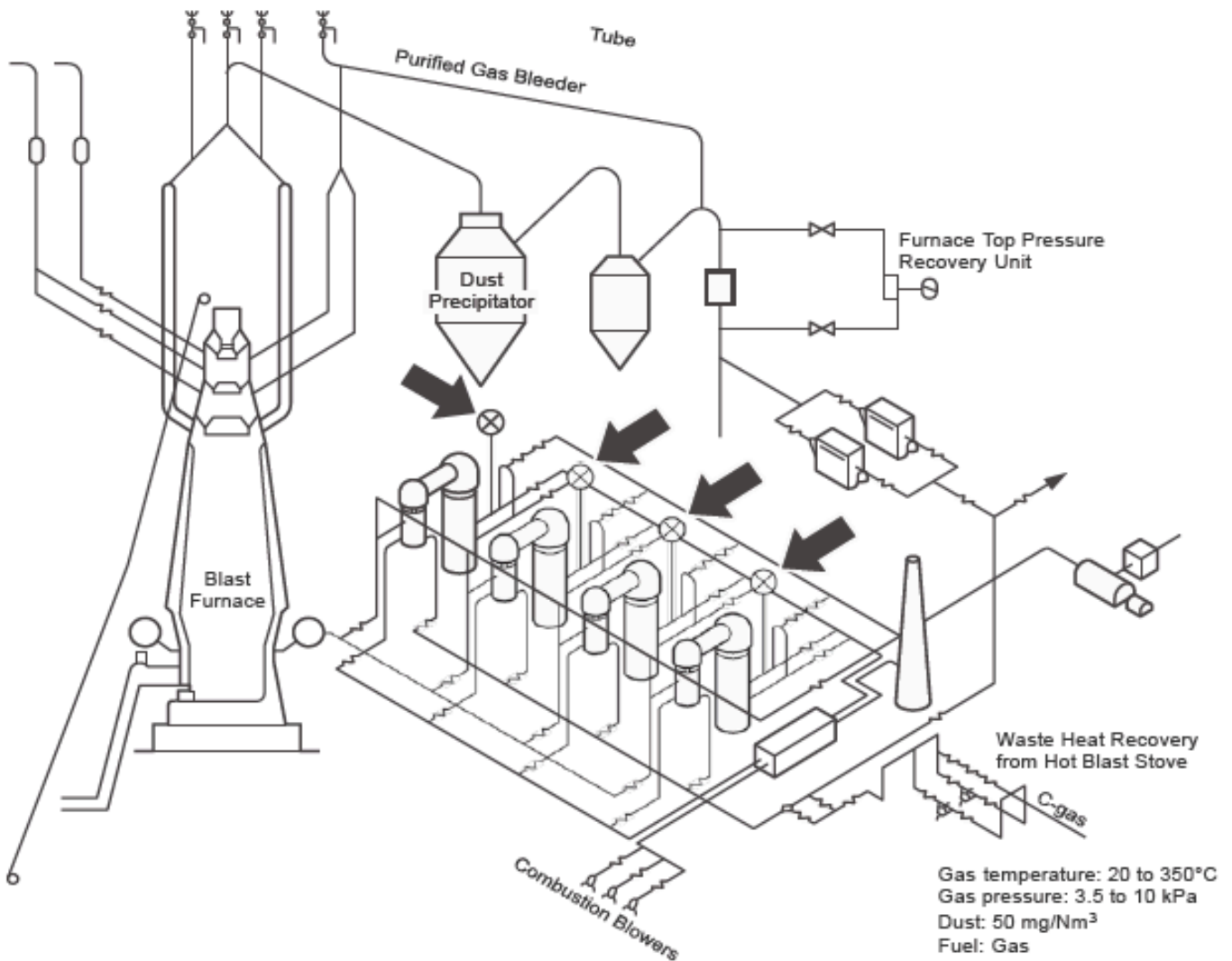

### 4.2.3 Coke oven facility

This facility is used to produce the coke used in the blast furnace.

The zirconia oxygen analyzer is used to monitor the exhaust gas from the heater combustion used for destructive distillation of the coal.

Sample point	Sample type	Detector	Objective
Flue	L2, L3	D1, (D2)	Combustion monitoring

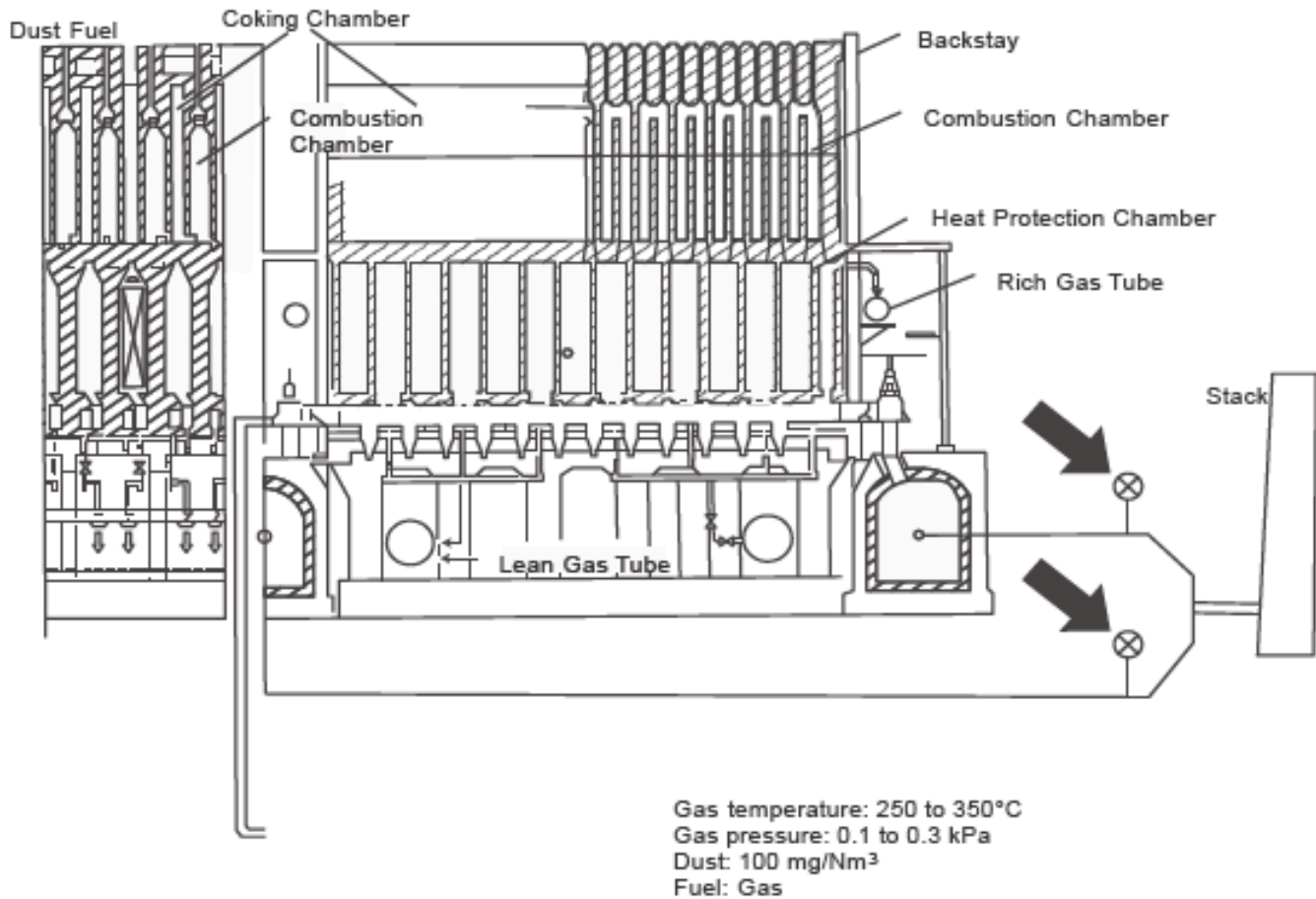



#### 4.2.4 Soaking pit

The soaking pit is a type of furnace used to maintain the ingots at a constant temperature. Oxygen concentration is controlled at a low level to suppress ingot surface oxidation.

Sample point	Sample type	Detector	Objective
Ahead of recuperator	H <sub>2</sub> , (H <sub>3</sub> )	D5	Combustion monitoring

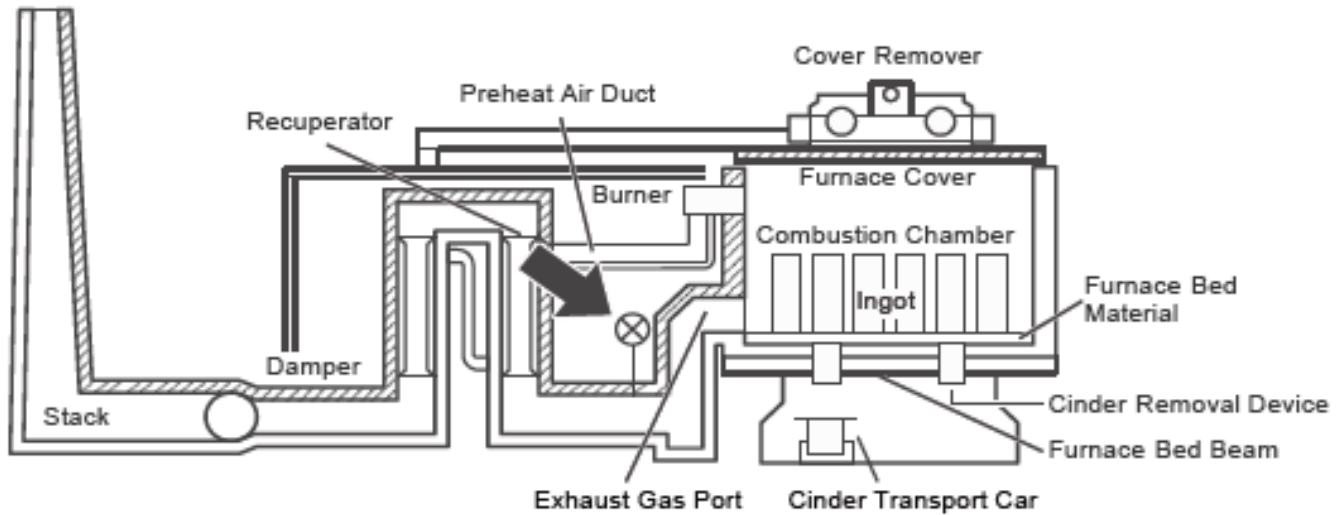

**Construction of unidirectional top section combustion soaking pit**

Gas temperature: 1000 to 1200°C  
 Gas pressure: 0.03 to 0.05 kPa  
 Dust: 0.5 g/Nm<sup>3</sup>  
 Fuel Gas

## 4.3 Ceramic, Brick, Glass & Cement Furnaces/Kilns

### 4.3.1 Rotary type lime kiln

The zirconia oxygen analyzer is used for combustion monitoring to conserve energy.

Careful attention to detector mounting position and orientation is required due to the presence of large amounts of abrasive particulates and intrusion air.

Sample point	Sample type	Detector	Objective
Kiln end	L2, L3 (H2, H3)	D4 (D3, D5, D6)	Combustion monitoring

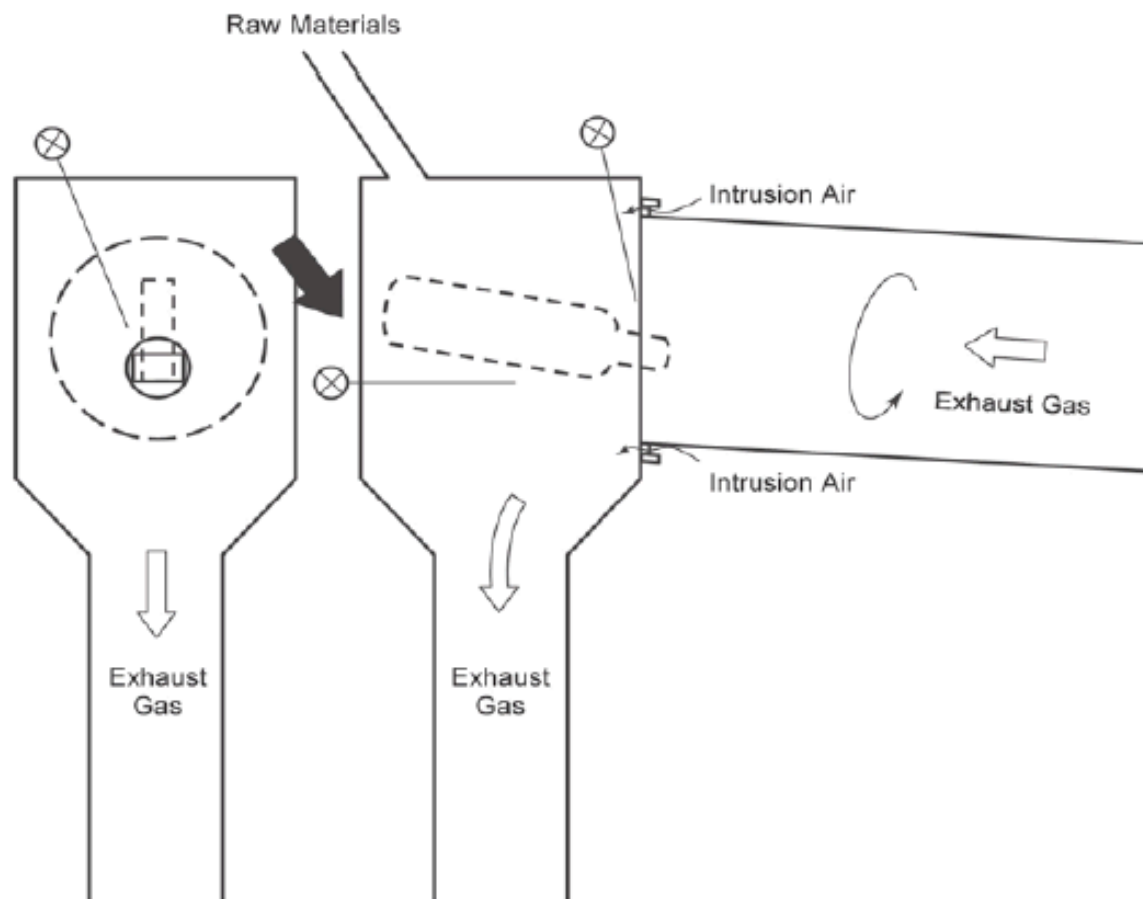

Gas temperature: 250 to 500°C\*1

Note 1: Depending on the kiln, there will be cases when the temperature at the measuring point will be 600°C or greater (600 to 750°C). Under these conditions, the high-temperature detector should be used.

### 4.3.2 Cement kiln (cyclone outlet gas)

Cement production consumes approximately 100 liters or more of fuel (heavy oil) per ton of cement. Thus, combustion management by means of zirconia oxygen analyzers has become a critical element.

There are cases in which O<sub>2</sub>, CO, and CO<sub>2</sub> measurements are performed using a sampling system at the kiln outlet.

Sample point	Sample type	Detector	Objective
Cyclone outlet	L2, L3	D4, (D3)	Combustion monitoring

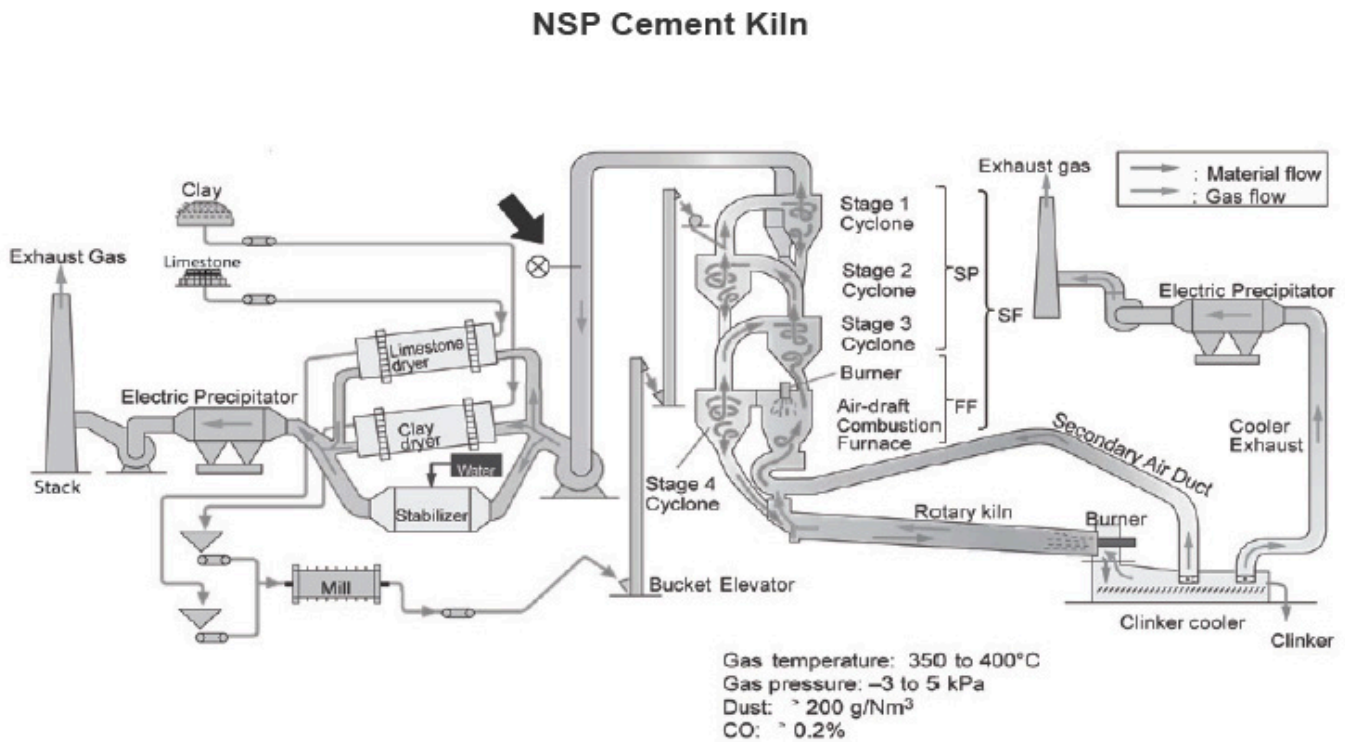

## 4.4 Petroleum Refining and Petrochemical Fired Headers

In petroleum refining and petrochemical plants fired heaters are so numerous that you could almost say that there is one in almost every process. Also, since a site consists not of just a single petroleum refining process but rather of ten or more processes, this means that you have that many fired heaters, too (located at the arrows in the diagram above).

In addition to the fired heaters, there will also be a number of boilers. Thus combustion monitoring (or control) is a vital element.

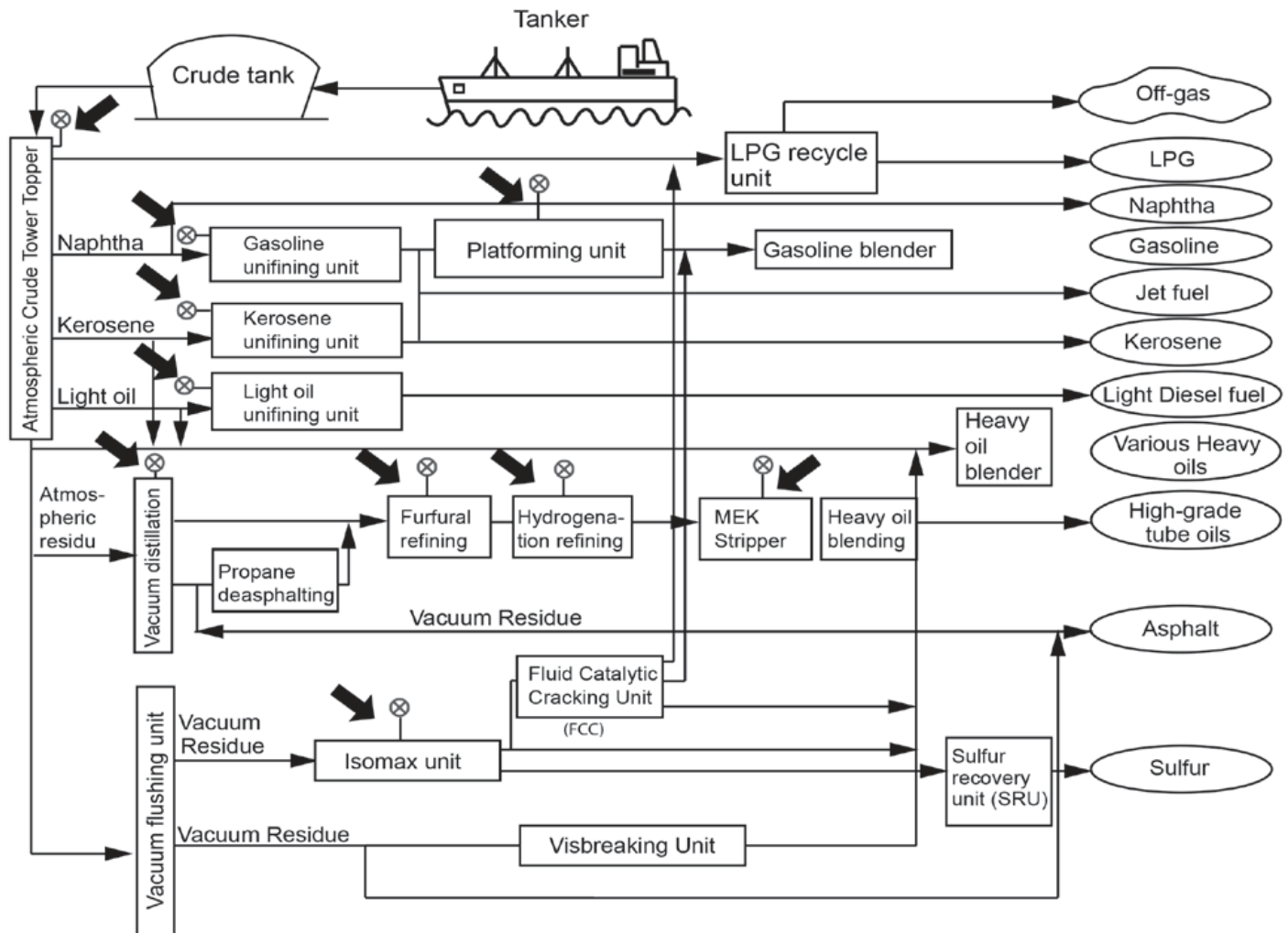

### 4.4.1 Naphtha cracking furnace

This is the first process in a petrochemical facility, in which the Naphtha supplied from the petroleum refinery is heated and cracked to produce a variety of products. There will be not just one but rather anywhere from six to twelve fired heaters, each with its own stack.

Analyzer installation locations		Sample point	System type	Detector	Objective
→	Fired heaters	Stack or convection	L2, L3 H2, H3 Explosion-proof type external terminal box may also be selected	D1, D2 D5, D6	Combustion monitoring

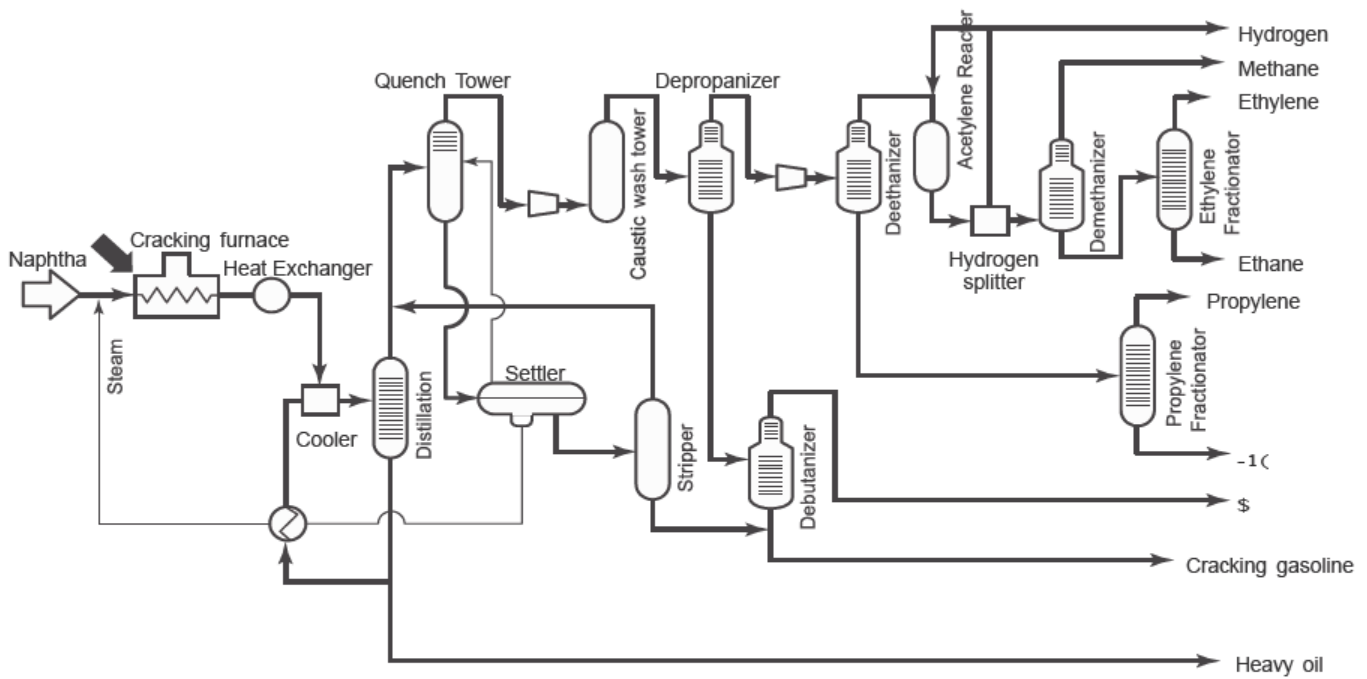

Temperature: Stack: 300 to 600°C  
 Convection: 600 to 1100°C  
 Pressure: -0.2 to 0 kPa  
 Dust: 1 g/Nm<sup>3</sup> max.

#### 4.4.2 Petroleum refinery process fired heater example

There are two possible locations for the sample point in fired heaters for petroleum refining and petrochemicals: in the stack, or in the vicinity of the furnace outlet (convection zone).

Sample point	System type	Detector	Remark
Stack	L2, L3	D1, D2	Explosion-proof type with terminal box may also be selected.
Furnace outlet (convection zone)	H2, H3	D5, D6	

Analyzer installation locations	Sample point	Temperature
1 → 2 →	Stack Convection	Approx. 300 to 500oC Approx. 600 to 900oC

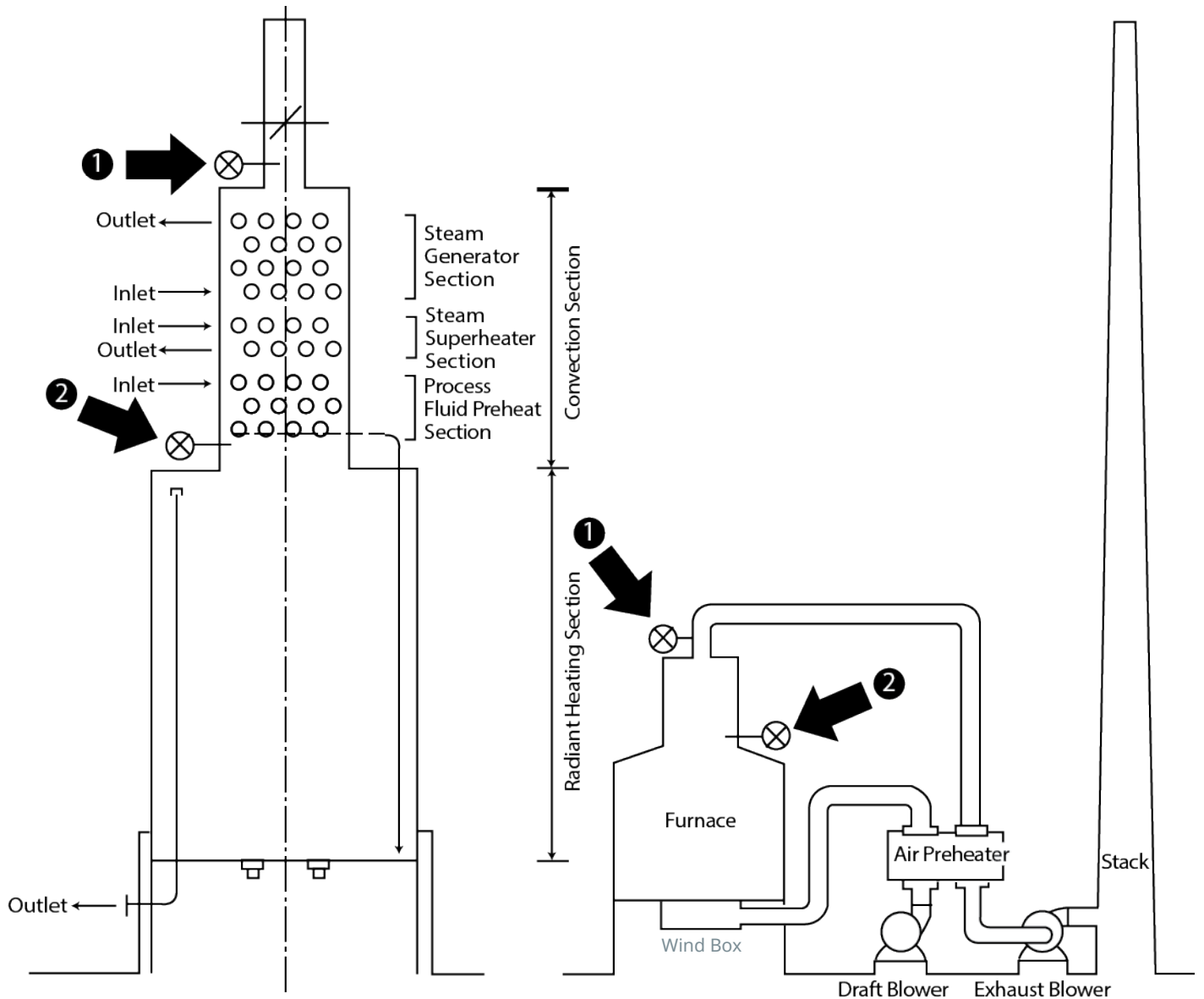

## 4.5 Garbage Incinerator

This is a facility to handle by incineration the combustible waste generally contained in municipal garbage.

The exhaust gas of the incinerator outlet contains large quantities of dust and corrosive gases, and a large water vapor component.

Yokogawa should be consulted concerning the installation of the unit.

Sample point	System type	Detector	Objective
Incinerator outlet (gas cooler outlet)	H2, H3 Note: depending on the conditions at the sample point, a sampling type system may be required.	D5	Combustion monitoring
Scrubber outlet (or stack)	L2, L3	D1, (D3)	Combustion monitoring

### Fluidized Bed Incinerator Plant

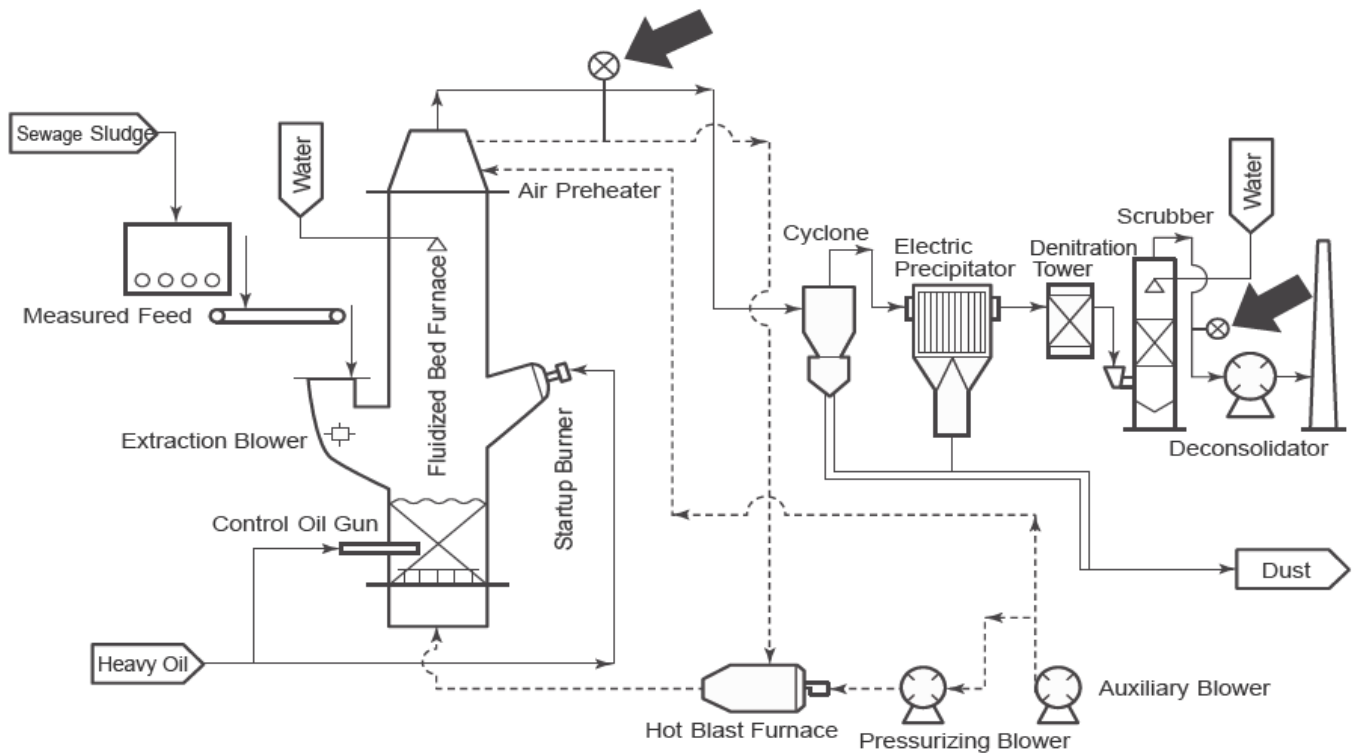

#### Incinerator outlet

Exhaust gas temperature: 700 to 750°C  
 Dust: 20 to 30 g/Nm<sup>3</sup>  
 Exhaust gas components: SO<sub>x</sub>; Several hundred ppm  
 HCl; 100ppm

#### Scrubber outlet

Exhaust gas temperature: 80 to 120°C  
 Dust: 0.1 g/Nm<sup>3</sup> maximum

## 4.6 Non-Combustion Applications

### 4.6.1 Oxygen enrichment facility

Although in most combustion systems air is used as-is, there are cases such as in blast furnaces in steel plants where the air will be enriched with oxygen gas to raise efficiency. When this is done, oxygen analyzers are used to monitor the oxygen generation unit (air separator, etc.), and/ or to check the condition of the mixing with the air in later process stages. In these cases, the oxygen analyzer will be measuring values higher than the concentration of oxygen in the air (approximately 21%).

Sample point	System type	Detector	Objective
Oxygen supply line Oxygen compressor outlet	H3 (Note 1)	Note 2	Operational monitoring
Air-oxygen mixing line	H3 (Note 1)	Note 2	Operational monitoring

Note 1: Measurement will be done using a sampling system, since all the points are at high pressure.

Note 2: The high-temperature detector should be used.

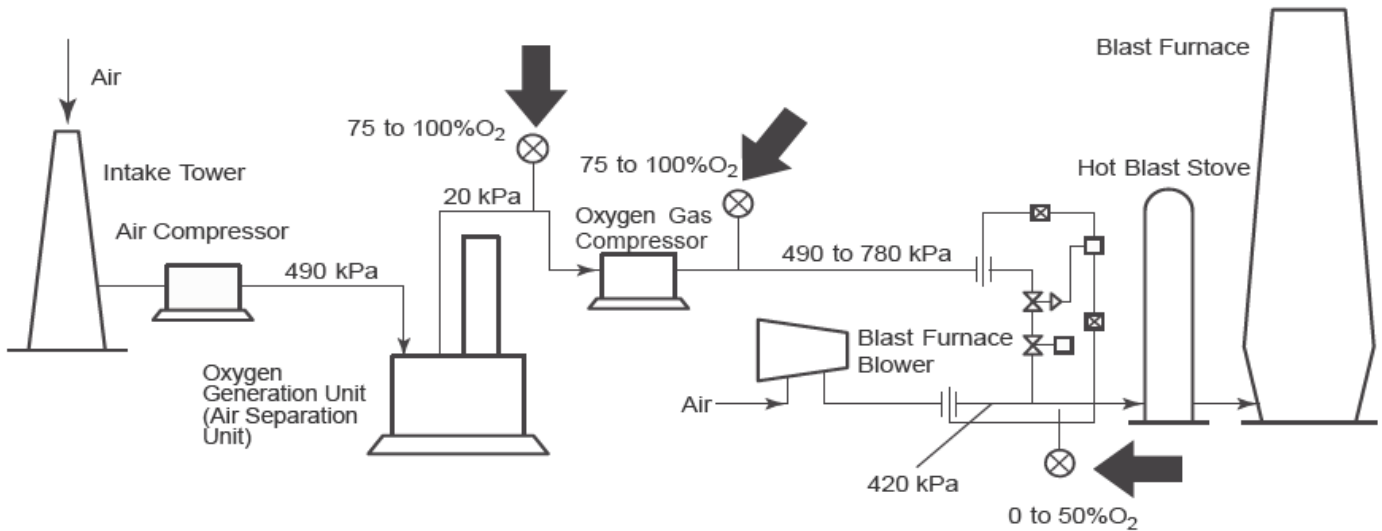

Note 1: Due to the high pressure, measurement will be done with a sampling type system.

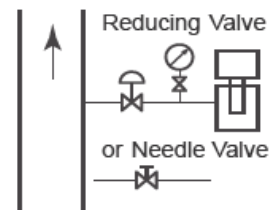



#### 4.6.2 Power generation boiler wind box

In large boilers such as those for power generation, part of the combustion exhaust gas is recycled to the combustion intake, and the oxygen concentration in the recycled gas is monitored so that it does not drop too low.

The analyzer range will be a partial range that includes the atmospheric oxygen concentration, such as 15 to 22% O<sub>2</sub>.

Sample point	System type	Detector	Objective
Wind box	L2, L3	D1 (Note)	O <sub>2</sub> control alarm

Note: The ZO21DW (terminal box explosion-proof type detector; pressure compensated type) or the ZR22G (pressure compensated type) will be used. These are many cases in which the AV550G averaging converter will be used.

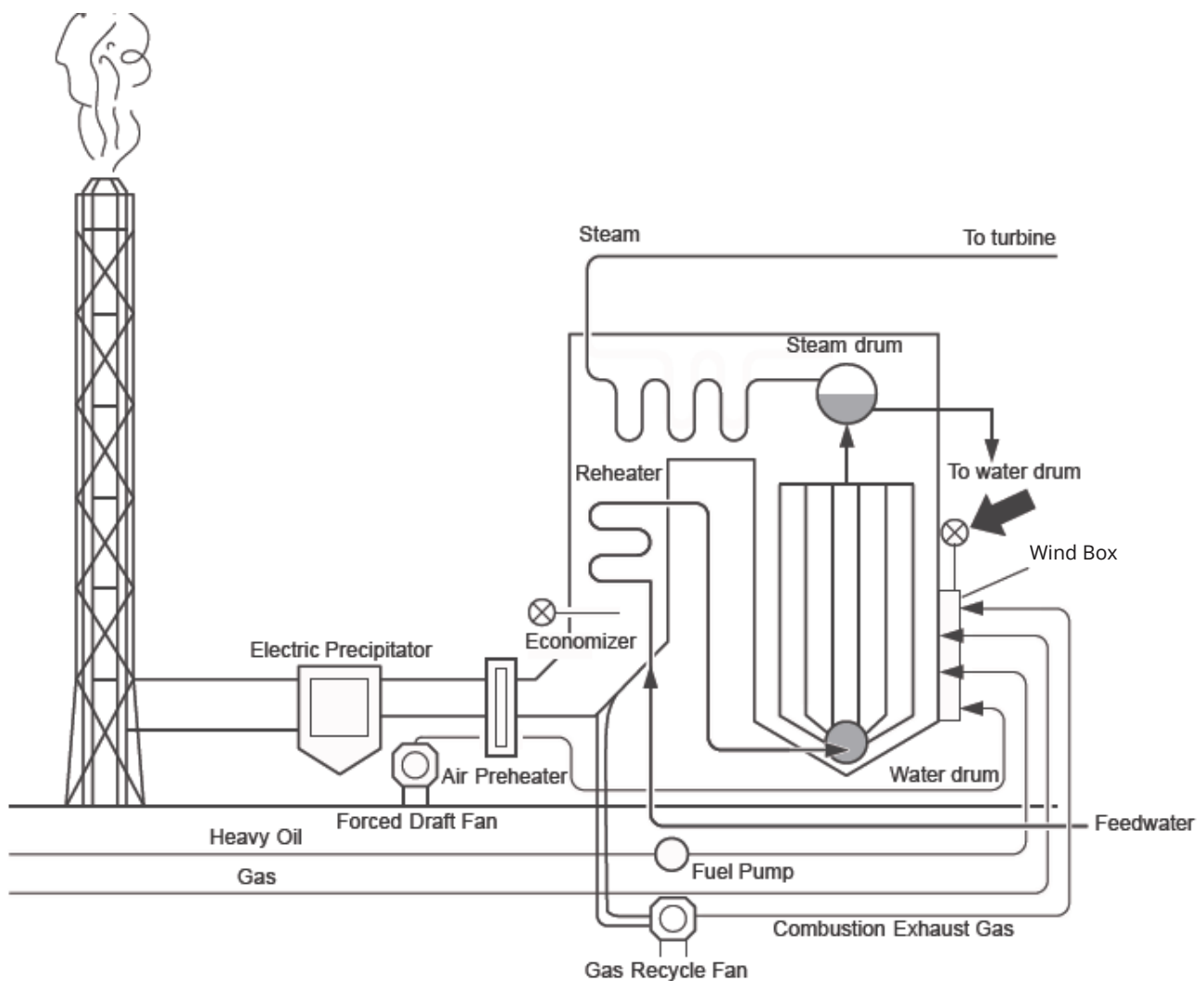

#### Power generation boiler wind box

Gas temperature: Max. 550°C  
 Gas pressure: -5 to 20 kPa

### 4.6.3 Aeration tank

In one type of sludge processing, oxygen gas is introduced into the processing tanks to maintain the dissolved oxygen concentration in the sludge liquid at a proper level. Efficiency is checked by measuring the oxygen concentration in the exhaust gas from the processing tank.

Sample point	System type	Detector	Objective
Exhaust line	L2, L3	D1	Efficiency monitoring and alarm

**Activated Sludge Processing Facility  
(Surface Aeration System Aeration Tank)**

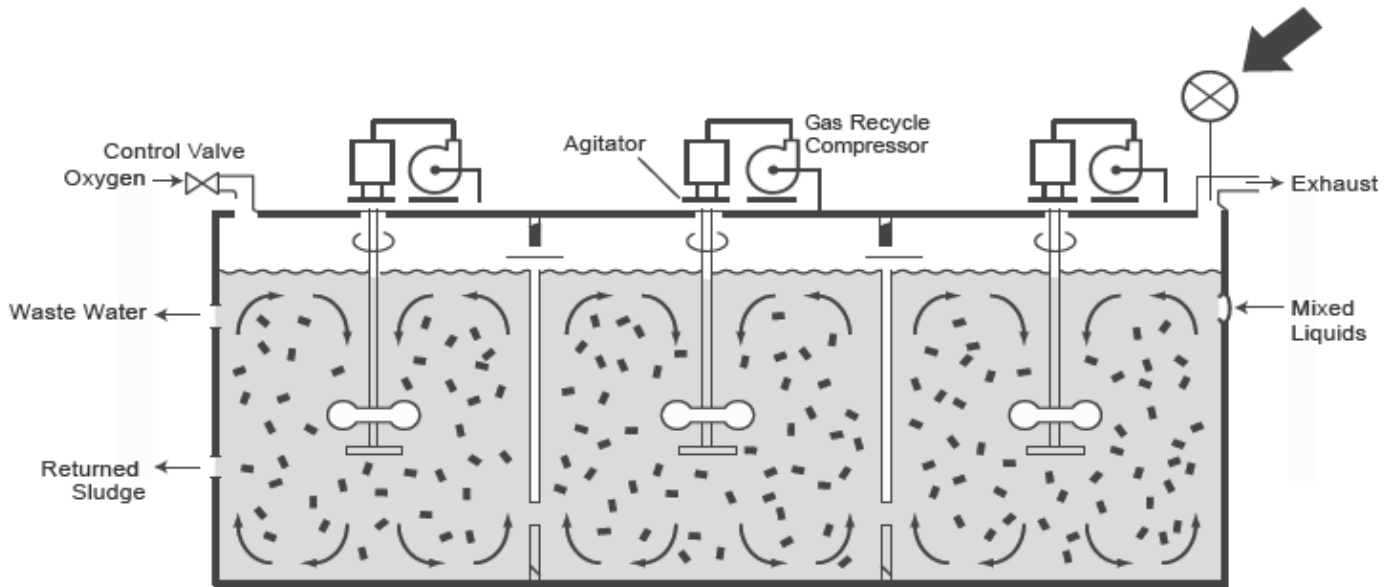

Gas temperature: Normal temperature  
 Gas pressure: 0 to 1 kPa  
 Concentration: Approximately 50%O<sub>2</sub> (0 to 100% range)

## 4.7 Difficult Measurement Applications

### 4.7.1 Glass melting furnace (in-furnace gas)

Oxygen concentration in glass melting furnace stacks can be measured with no problems the same as in other general combustion exhaust gas applications.

Glass melting furnace (stack): Temperature 0 to 600°C  
System block diagram type No: L2, L3

On the other hand when we come to measurement of the gas inside the furnace, continuous measurement with a direct in situ zirconia oxygen analyzer (high-temperature system) is either extremely difficult or impossible due to the dust and fumes from the components of the glass. However, since continuous measurements are being performed in some cases by the method shown in the diagram, we offer this for your reference.

### Glass melting furnace configuration and with detail of ZR22G Installation

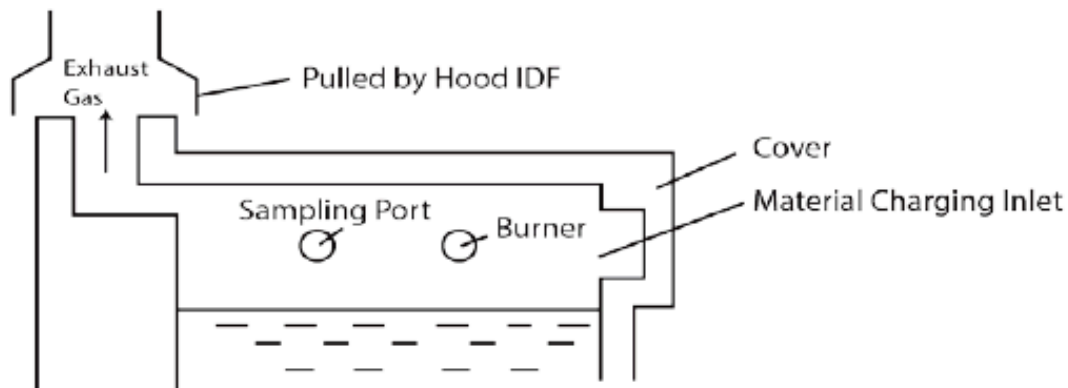
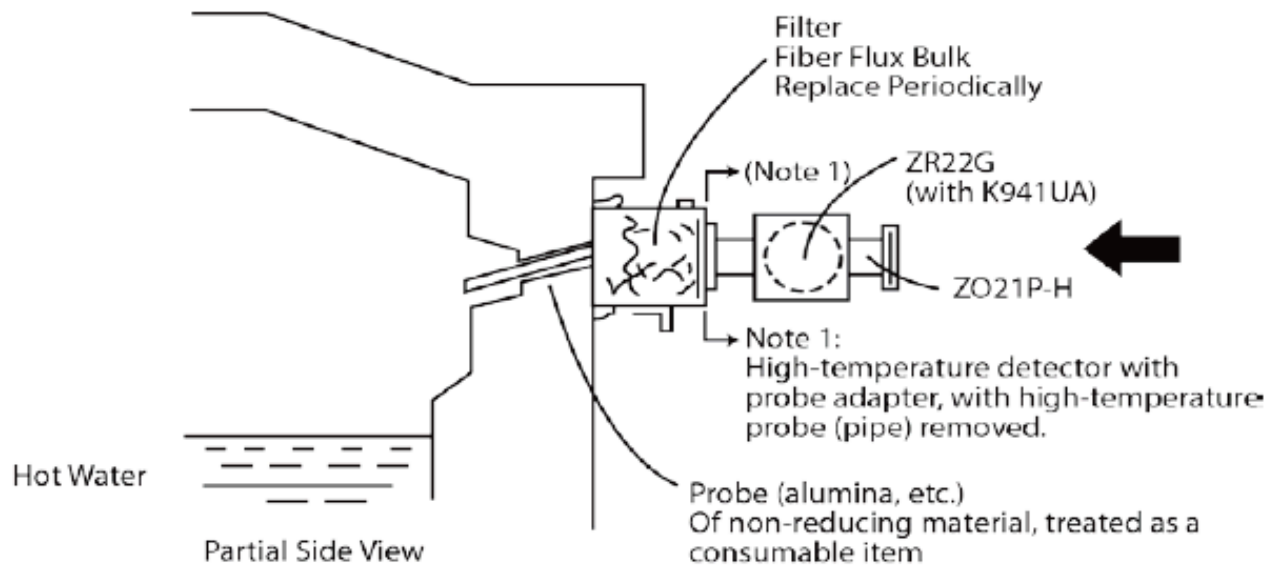

Gas Temperature: Norm. 1,200°C  
Max. 1,300°C

Fuel: Butane gas  
O<sub>2</sub> 5%

Dust level: Normal; Low  
During material charging; High  
3 to 4 cycles/hour



- Do not mount the probe with the tip higher than the probe base
- If the probe length is 2.5 meters or more the detector should be mounted vertically (no more than a 5 degree tilt)
- The detector probe should be mounted at right angles to the measurement gas flow or the probe tip should point downstream
- *Documentation shows the image below indicating the appropriate hole for each assembly type. However, this does not take into consideration all of the products offered globally and it is recommended that the hole always be a minimum of 65 mm. This allows for installation of all filter types on the first installation or after initial installation if one needs to be added later.*

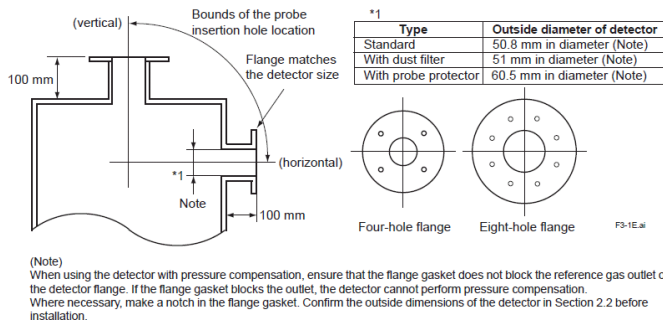

Fig 5.2 illustrates an example of the probe insertion hole

### 5.2.3 Installation of the Detector

The following should be taken into consideration when mounting the general-use detector:

- The cell (sensor) at the tip if the detector is made of ceramic (zirconia); Do not drop the detector, as impact will damage it.
- A gasket should be used between the flanges to prevent gas leakage. The gasket material should be heatproof and corrosive-proof, suited to the characteristics of the measured gas

General-use:

- Make sure that the cell mounting screws (four) at the probe tip are not loose. If a dust filter is used, make sure it is properly attached to the detector.
- Where the detector is mounted horizontally, the calibration gas inlet and the reference gas inlet should face downward.

### 5.2.3.1 Good and Bad Example Guide

Typical good/bad installation examples are shown below for your reference

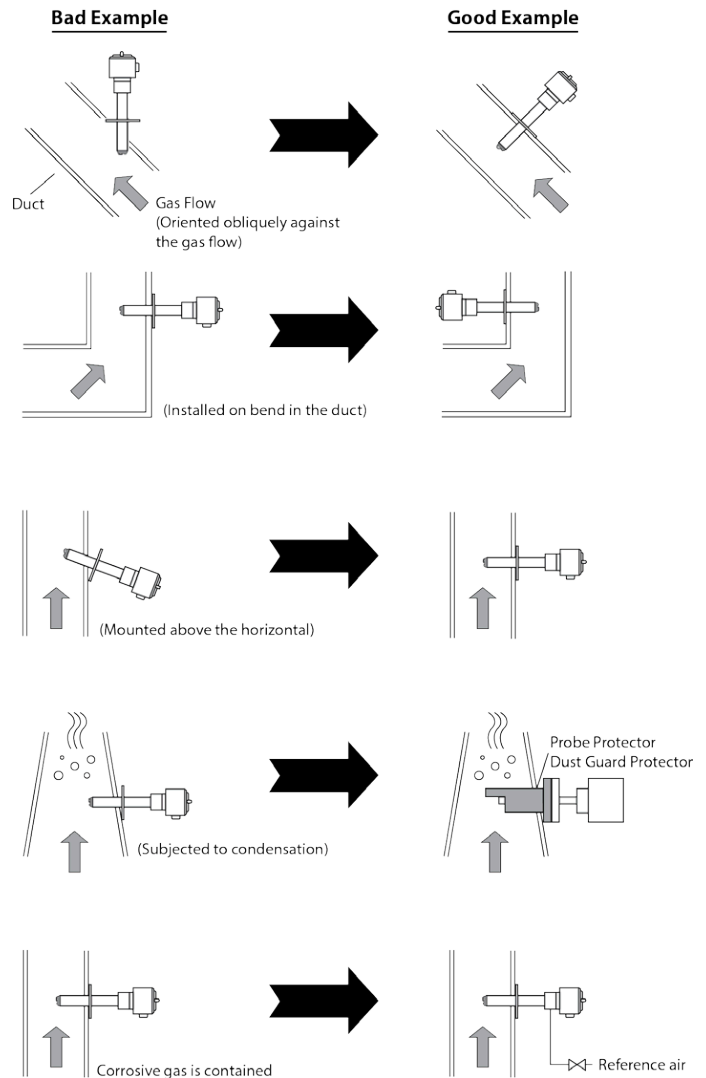

## 5.3 Installation of the Accessories and Parts

### 5.3.1 Filters

#### 5.3.1.1 Dust Filter (Part No. K9471UA)

- The dust filter is used to protect the Zirconia sensor from corrosive dust or a high concentration of dust such as in utility boilers and concrete kilns. If a filter is used in combustion systems other than these, it may have adverse effects such as response delay. These combustion conditions should be examined carefully before using a filter.
- The dust filter requires gas flow 01-1 m/sec. or faster at the front surface of the filter (K9471UA)

**\*\*Mount the dust filter assembly by putting it on the end of the detector and screw the assembly clockwise. Put a hook pin wrench (K9471UX), 52 to 55 in diameter, into the hole on the assembly to fasten or remove it. Apply a heat-resistant coating to the threads on the detector. When remounting Filter assembly after having once removed it from the detector and reapply the heat-resistant coating**

### 5.3.1.2 Dust Filter (option Code "/F1")

This option is also part of the model code 01 ZR22 detector. This is a Carborundum/SUS316 filter of 30 microns used to protect the cell from corrosive dust components or high velocity dust. This component is must except for gas fired boilers.

### 5.3.1.3 Fly Ash Filter (Part No. M1234SE-A)

- Slide the closed end of the filter shield over the end of the probe approximately 9 inches.

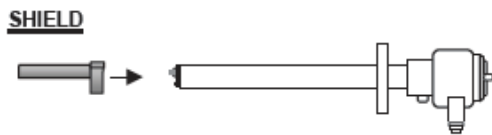

- Slide the filter element over the detector and into the space between the detector and the shield approximately 8 inches. This may be a snug fit, and might require a firm push; however, the filter should not be forced onto the detector.

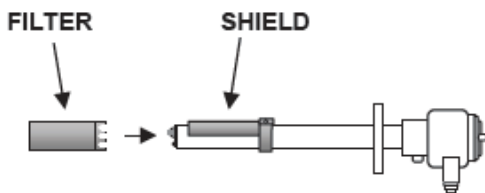

- Slide the end of the shield over the filter

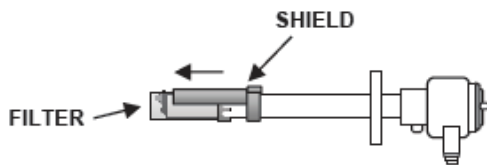

- Align the shield so it protects the filter element from direct gas flow. The shield should cover the filter, and be flush with the closed end of the filter, as shown:

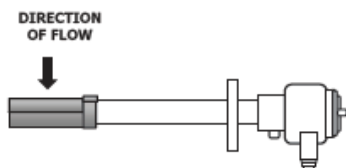

\*NOTE: When using the M1234SE-A Self Cleaning Fly-Ash Filter in conjunction with the ZR22R Probe Protector, repeat the steps above, but invert the M1234SE-A shield away from the direction of flow.

- Tighten the clamp screw until the filter cannot be moved by hand. The filter will be fully tightened before the space between clamp block is completely closed. THE SCREW SHOULD NOT BE TIGHTENED BEYOND THIS POINT. Over tightening the assembly can damage the detector and filter.



### 5.3.2 Check Valve (Option Code "/CV")

This option is part of the model code of ZR22\* detector. This Check valve should be connected at the "Calibration In" port of the Probe head. This check valve is nothing but a non, return valve & it ensures that the calibration gas flows from Calibration Unit to probe head only and there is no reverse flow from probe head to Calibration Unit. The check valve can be used when using either automatic calibration or manual calibration.

If this Check valve is not installed at the probe head there may be back flow of process gas to Calibration Unit and this process gas which consists of moisture will get condensed in calibration gas line while coming in contact with ambient temperature. Due to this, during next calibration cycle this moisture will be carried to zirconia cell. As the zirconia cell is always heated up to 750°C, the moment moisture hits the cell it will give thermal shock & the cell will break immediately.

To avoid this, it is a must to select option code /CV while selecting the model code. While commissioning the analyzer, Check Valve must be installed at the probe head before it is inserted in the stack.

Please note that a Stop valve is also available however, it can only be used when manual calibration is being used.

### 5.3.3 Probe Protector

This is essentially an SS316 sleeve connected with SS304 flange to the Analyzer Probe. This is illustrated in the Fig. 5.3 drawing. As the name suggests, this is used to protect the probe from erosion. As there is a higher velocity flow of flue gases thru' the stack, it will cause erosion to the probe if it is installed in the stack without Probe Protector. Probe Protector is a consumable item & it should be inspected at regular intervals so as to

check its health and if found some signs of erosion, it should be replaced immediately. By replacing Probe Protector which is a low value item, we are able to safeguard our Analyzer Probe which is much costlier to replace.

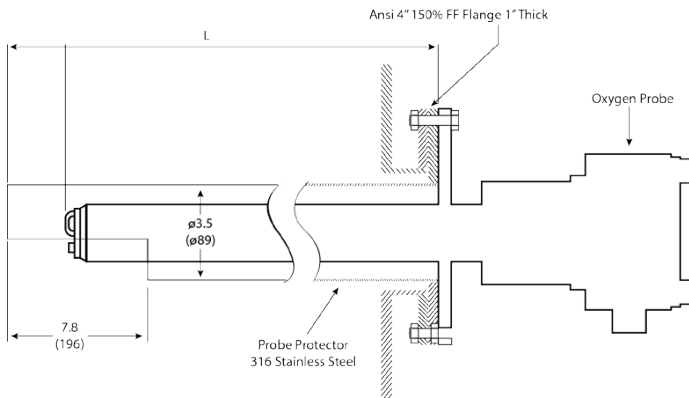

Figure 5.3 Probe Protector (Z021R/ZR22R)

### 5.3.4 Calibration Units

Calibration Unit (Either Manual or Automatic) allows calibration gases to pass thru' the cell during calibration. It also regulates & filters the Instrument grade air before it is flowing thru' the Reference side of the cell.

This is essential because if plant instrument air contains the moisture, it will again give thermal shock to the cell & will break the cell. To overcome this problem, it is advisable to use Calibration Unit.

The zero gas normally used has an oxygen concentration of 0.95 to 1.0 vol%O<sub>2</sub> with a balance of nitrogen gas (N<sub>2</sub>). The span gas widely used is clean air (at a dew-point temperature below -20 deg C and free of oily mist or dust, as in instrument air).

## 5.4 Installation of the High Temp Tee (Z021P/ZR22P)

### 5.4.1 Probe Insertion Hole

A high temperature detector consists of a ZR22G-015 Detector and Z021P High Temperature Probe Adapter (Z021P/ZR22P). When forming the probe insertion hole, the following should be taken into consideration:

- If the probe is made of silicon carbide (SiC), the probe hole should be formed so that the probe is mounted vertically (within  $\pm 5^\circ$  tilt).
- In the case where the probe is made of stainless steel and the probe adapter is to be mounted horizontally, the probe hole should be formed so that the probe tip is not higher than the probe base.

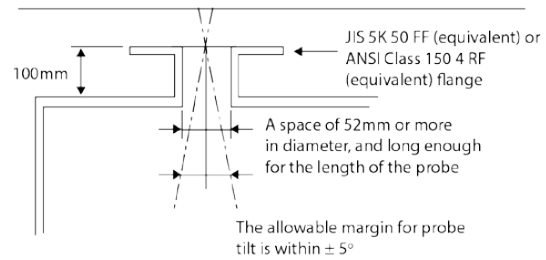

An SiC probe shall be mounted vertically.

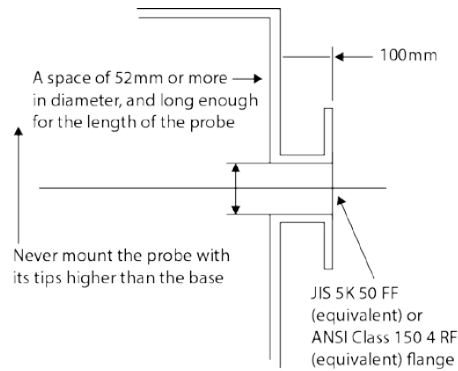

Horizontal mounting is used with a SUS probe.

Figure 5.4 High temperature mounting

### 5.4.2 Probe Adapter

During analysis, the surface temperature of the probe adapter should be within the range from more than the dew point of the sample gas and 300°C or less to prevent ejector clogging, gasket deterioration or bolt scoring.

Where the dew point of the sample gas is not known, keep within the range of more than 200°C to less than 300°C.

The temperature shall be measured at the probe in the probe adapter and the surface of the blind flange at the opposite side.

When the surface temperature is not within the above range, the following measures can be taken to change the temperature.

#### When the surface temperature exceeds 300°C

- When the furnace pressure is negative, lower the pressure setting to reduce induction flow of the sample gas.
- Ejector Assembly for High Temperature, for the setting of induction flow. When you reduce induction flow, ensure that the ejector inducts air when the furnace pressure fluctuates.

- When the furnace pressure is positive, close the needle valve for the sample gas outlet to reduce the exhaust gas flow.
- Ensure that the temperature of the probe adapter does not fall below the dew point of the gas in winter.
- To prevent temperature rises due to radiant heat, insert heat insulator between the wall of the furnace and the probe adapter.
- To prevent temperature rises from thermal conduction, place the mounting flange as far from the wall of the furnace as possible.

### When the surface temperature is less than 200°C or below the dew point of the sample gas

- When the furnace pressure is negative, raise the pressure setting to increase induction flow of the sample gas. If there is much dust in the gas, the ejector may become clogged as induction flow increases.
- When the furnace pressure is positive, open the needle valve of the sample gas outlet to increase the gas flow.
- Warm the probe adapter.
- When the surface temperature is still less than 200°C or below the dew point of the sample gas, even if the above measures have been taken, warm the probe adapter using a heat source such as steam.

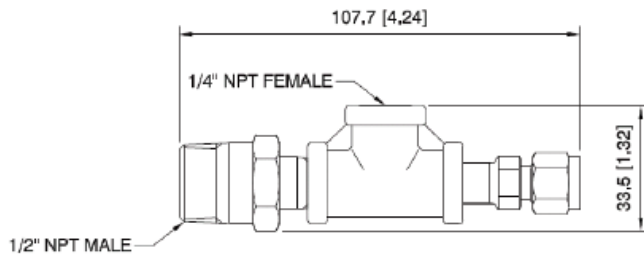

Figure 5.5 Drawing of Ejector, P/N M1234XE

## 5.5 Installation of the Analyzer (ZR402G/AV550G)

### Proper Installation Site of the Converter needs the following:

- Allows the operator to easily access/use for inspection and maintenance.
- Do not mount the converter in direct sun light.
- An ambient temperature of not more than 55°C and the temperature variation should be small: the daily temperature range within 15°C is recommended.
- Humidity is moderate (40 to 75% RH) and no condensation may occur.
- No corrosive gases are present.
- No dust exists.
- There is minimal vibration.
- The converter should be near the detectors: the two-way resistance between detector and converter should not exceed 10Ω.

- A wall or construction should be strong enough to support the weight of the converter
- Signal and heater cables should be installed in separate conduits.
- Shields on all cables should be landed on 1 end only.
- Make sure all wire lugs are tight.
- Do not splice cables. One continuous cable is recommended.
- Avoid grounding out the heater wires. It can damage the electronics.

The following guidelines below should be taken into consideration when installation the AV550G:

The averaging converter is designed for indoor installation and should be installed in the instrument panel in a control room. For outdoor installation, the averaging converter should be installed in an outdoor instrument panel protected from direct sunlight and the weather. The outdoor site location should be equipped with a cooling system for controlling the internal temperature, if necessary. Also, the outdoor case should be installed in a location that keeps the case free from corrosive gases or dust.

*\* For more detail information about the analyzer installation refer to the appropriate Instruction Manuals.*

## 5.6 Installation of the Integral Zirconia Oxygen Analyzer (ZR202\*)

It is the same as installation of ZR22G. However the ambient temperature of the ZR202G Integrated type Zirconia Oxygen analyzer should be between - 20°C and 55°C.

## 5.7 Installation of the OX400

Be sure to observe the following precautions when connecting the gas pipe to the OX400:

- The connections for both the gas inlet and outlet are Rc1/4 or 1/4NPT. Use the specified thread and securely connect the gas pipe so that no leakage will occur.
- When screwing in the pipe, be sure to hold the inlet hexagonal part in place with a wrench or the like. Not doing so and using a strong force when screwing in the pipe may cause the thread on the OX400 to rotate, resulting in damage to the internal pipe.
- With respect to piping, use a metal pipe. Use of materials such as plastic, vinyl, rubber, and the like may result in inaccurate measurements due to the transmission of oxygen from the air and absorption onto the inside surface of the pipe. Particularly with respect to silicon tube, be careful because due to its large oxygen transmission rate, accurate



measurements cannot be performed in the low concentration range.

- Be careful of leakage from the pipe because it may cause measurement errors. Particularly in the low concentration range, take great care because even though the pressure inside the pipe is positive, oxygen may flow from the air due to diffusion, resulting in a large error.
- Fluctuations of back pressure at the pipe outlet may cause measurement errors, so always keep the pressure at the atmosphere pressure level as much as possible during operation.

Built-in pump (Sampling method [-P])

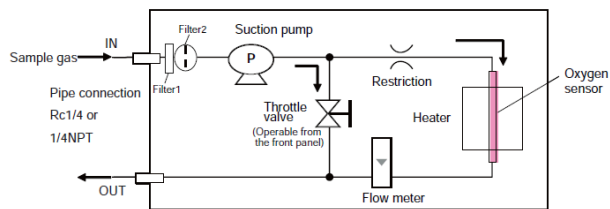

With aspirator (Sampling method [-A])

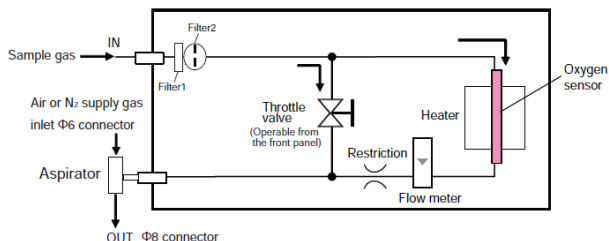

\*NOTE: If no suction device [-N] is specified, the aspirator is removed from this diagram. Refer to sec. 6.4 in IM when using aspirator.

## 5.8 Installation of the OX100/ OX102

### 5.8.1 Installation of the Sensor

Use the nipple provided as an accessory, mount it horizontally and secure it so that it cannot vibrate.

- When tightening, for cap use torque of 1 to 1.5 Nm, and for other items use torque of 2 to 2.5 Nm.
- Sensor cable should be within 30 cm of sensor housing, and angle of bend (see figure below) should not be greater than 60°.
- When mounting sensor through a 17 mm hole, mounting plate should be no greater than 4 mm thick.

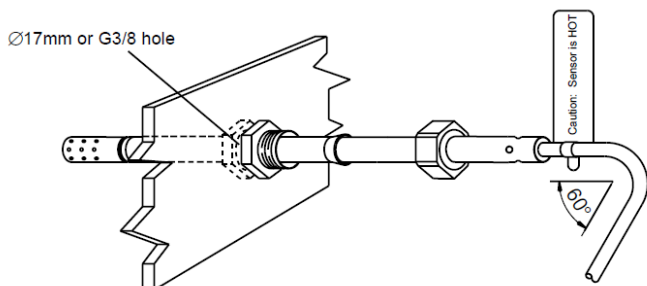

### 5.8.2 Installation of the Sampling unit (K9424GA)

The sampling unit is a desktop type and should be installed on a stand near the sampling point. Note the following when installing the unit. The unit should be installed in places where:

- Ambient temperature is in the range of 0 to 40°C and temperature fluctuations are minimal.
- Mechanical vibration is negligible.
- Adequate space for inspection and maintenance, such as replacing filter element, is secured.
- The unit should be securely mounted on a stand to prevent it falling.
- No exposure to rain or water is allowed.

The sampling unit incorporates a suction pump, which requires power supply of 100-240VAC.; The pumps and activated charcoal filter used in this equipment have limited life, and periodic maintenance or replacement will be required. Install this equipment in an accessible location to facilitate maintenance.

Maintenance conditions vary depending on the gas conditions. Replacement intervals for the filter and activated charcoal should be determined in accordance with the operating conditions.

- Used eight hours a day, pump life will be approximately one year.
- Filter life is about 50 hours. (if measured gas contains isopropyl alcohol of concentration 500 ppm, and flow is 500 ml/min.)

## 6. Selection Guide

### 6.1 Oxygen analyzer selection flow chart

The Oxygen Product Selection Guide is designed to assist you in the selection of the appropriate oxygen analyzer system for your application. To make the most appropriate selection, you will need to know a few things about your application such as temperature, pressure, flow-rate, and area rating. If you should find that your application requires equipment beyond what is shown here, please fill out the application data sheet at the back of this document and forward to your local Yokogawa representative.

To use this guide, begin with the Oxygen Analyzer selection and follow the flow charts to build your model codes as you answer "yes" or "no" questions.

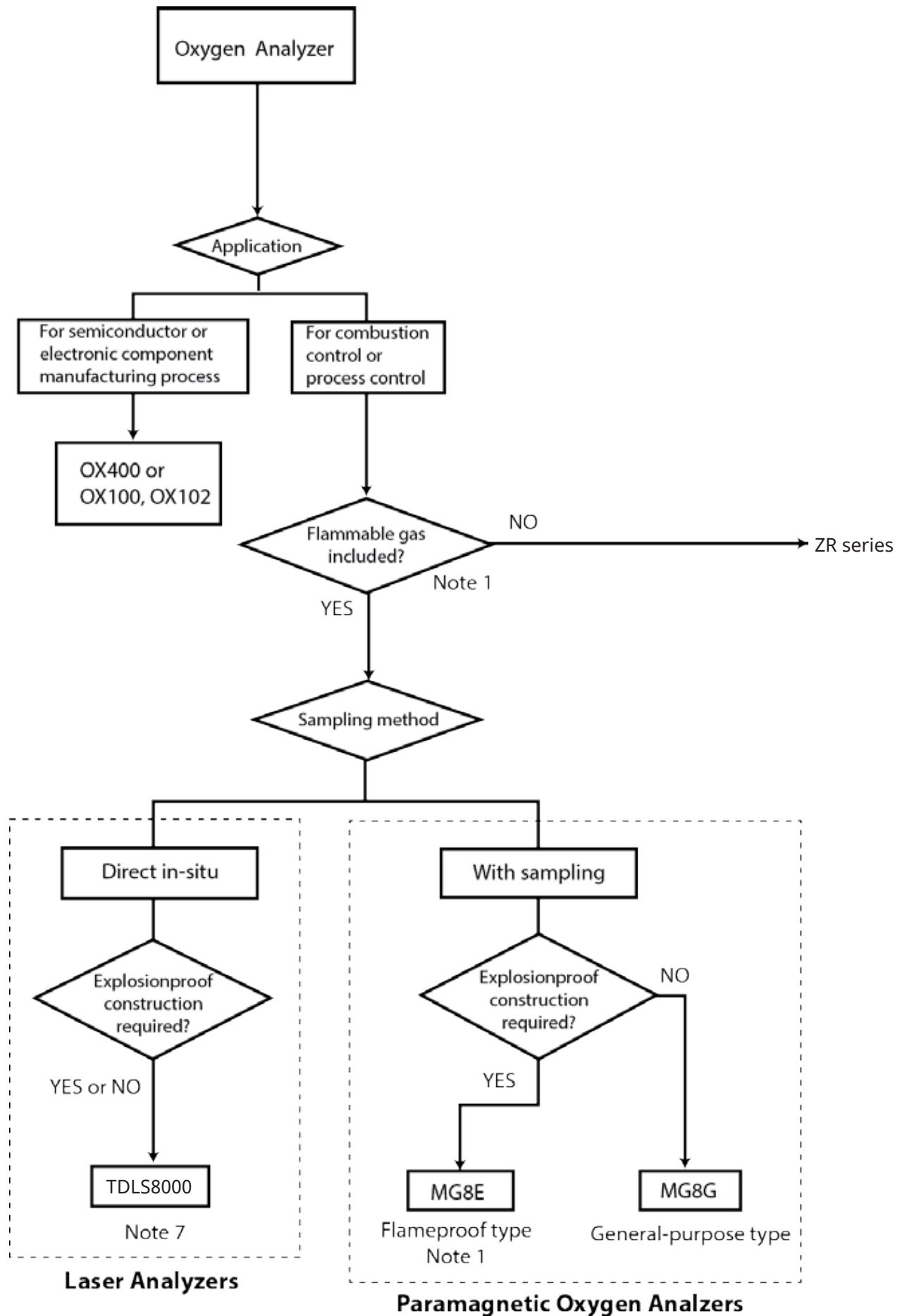

## ZR Series

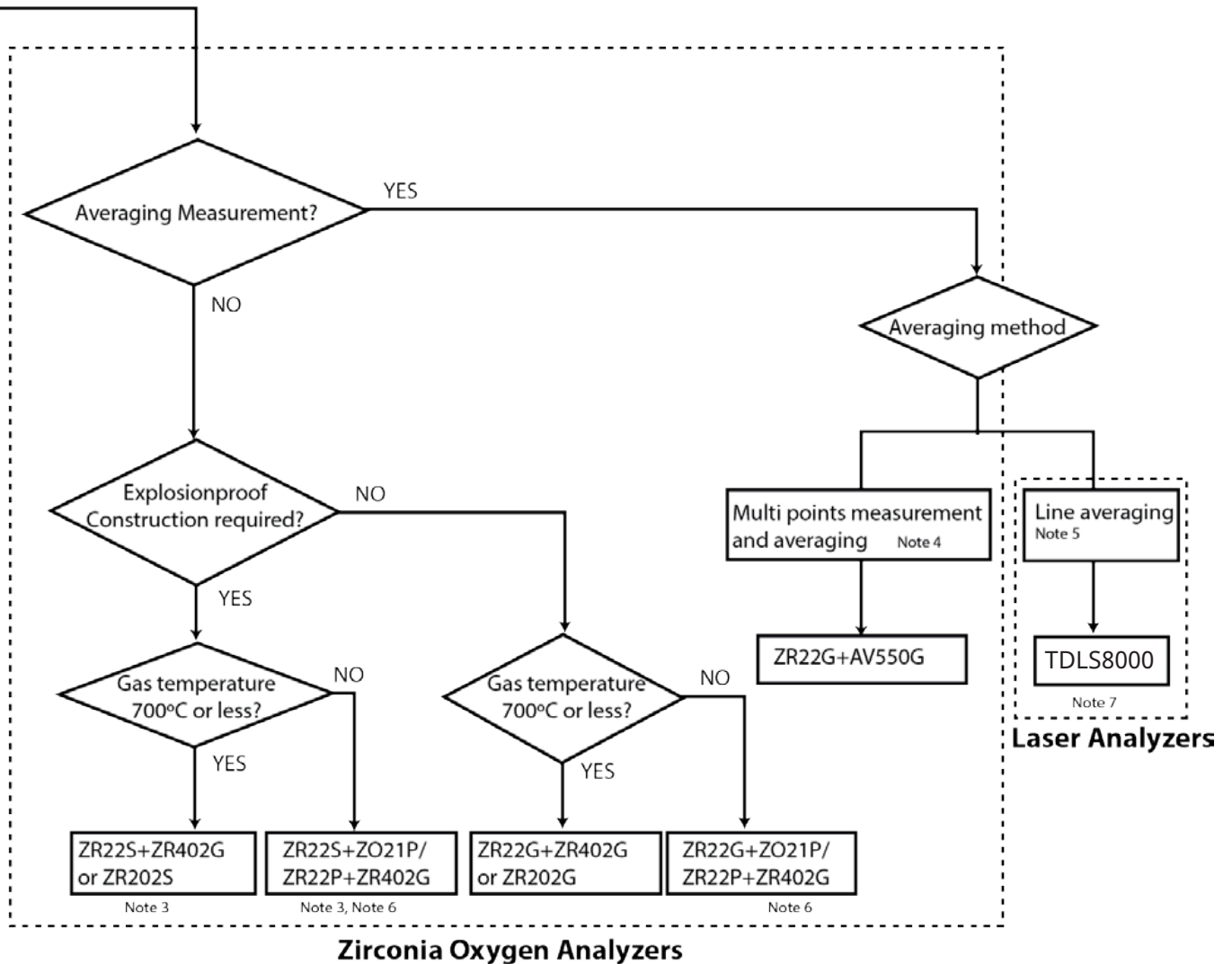

Note 1: If the content of a flammable gas is 0.5% of measuring range or less, select "NO" of flowchart.

Note 2: Instruments are all handled as custom orders.

Note 3: ZR402G converter must not be located in hazardous area.

Note 4: Max. 8 points measurement and averaging.

Note 5: Optical path averaging

Note 6: ZO21P/ZR22P, High temperature probe adapter

Note 7: ATEX Group II for zone 1 (Cat 2G) or zone 2 (Cat 3G) with purge systems

## 6.2 System configuration

This section includes two types of system selection guides for direct in situ zirconia oxygen analyzers. The reader should refer first the examples of system selection by application, and then examine the system block diagram and component device overviews.

### 6.2.1 ZR402G/ZR22 Direct In Situ Zirconia Oxygen

#### 1) System Selection Examples, by Application

Application		General-purpose detector (0 - 700°C)		High-temperature detector (700 - 1400°C)	
		System types	Detector	System types	Detector
Common	Boiler (fuel oil, gas)	L1, L2, L3	D1, (D2)	H2, H3	
	Boiler (pulverized coal, fluidized bed)	L2, L3	D4	H2, H3	
	Boiler (bark, wood scrap)	L2, L3	D3, (D1)	H2, H3	
Iron & steel	Heating furnaces & soaking pits	L2, L3		H2, H3	D5
	Hot blast stove	L2, L3	D1	H2, H3	
	Coke ovens & annealing furnaces	L2, L3	D1, (D2)	H2, H3	D6, (D7)
	Sintering furnace	L2, L3	D1, (D4)	H2, H3	
Non-ferrous metals	Heating, sintering & melting furnaces	L2, L3	D1, (D4)	H2, H3	D5, (D6)
Ceramic, brick, glass & cement manufacture	Coal kilns (rotart & vertical)	L2, L3	D4, (D3)	H2, H3	(D5, D6)
	Cement kilns (cyclone outlet)	L2, L3	D4, (D3)	H2, H3	
	Glass melting furnaces (inside furnace)	L2, L3		H2, H3	D5, (D6)
	Glass melting furnaces (flue)	L2, L3		H2, H3	D5, (D6)
	Ceramic firing furnaces	L2, L3		H2, H3	D5, (D6)
Petroleum/ Petrochemical	Fired heaters & cracking furnaces	L2, L3	D1, (D2)	H2, H3	D5, (D6)
Pulp & paper	Black liquor recovery boilers	L2, L3	D3, (D4)	H2, H3	
Other	Electrical generating boilers (window box)	L2, L3	D1	H2, H3	
	Garbage & sludge incinerators	L2, L3	D1, D3	H2, H3	D5
	Oxygen enrichment equipment	L2, L3		H2, H3	D7*

The meanings of these codes are explained on the pages that follow.

Note 1: Sampling system is required due to the high pressure.

The symbol such as L1 and D1 used in “the Types of System Configuration and Detector” are only applicable in this Technical Information document for quick reference. They do not appear in other literatures including the bulletin, general specifications, or user’s manual.

## 2) System Block Diagram Types

System Type No.	Detector	System Type			Remarks
		Simple Type	General Type		
		—	Manual Calibration	Automatic Calibration	
L1	General-purpose	o	x	x	using ZO21S standard gas unit
L2	General-purpose	x	o	x	using instrument air & zero gas cylinder
L3	General-purpose	x	x	o	using instrument air & zero gas cylinder
H1	High-temperature	o	x	x	using standard gas unit
H2	High-temperature	x	o	x	using instrument air & zero gas cylinder
H3	High-temperature	x	x	o	using instrument air & zero gas cylinder

O: Yes, X: None

### 6.2.2 Selection According to Use

Available model accessory table

Accessory	Model Code
High temperature probe adapter	ZO21P-H or ZR22P
Auto calibration unit	ZR40H or IAC24/AC1

Please check the general specification which model is available in your area.

#### (1) Type: L1 (simple measurement system)

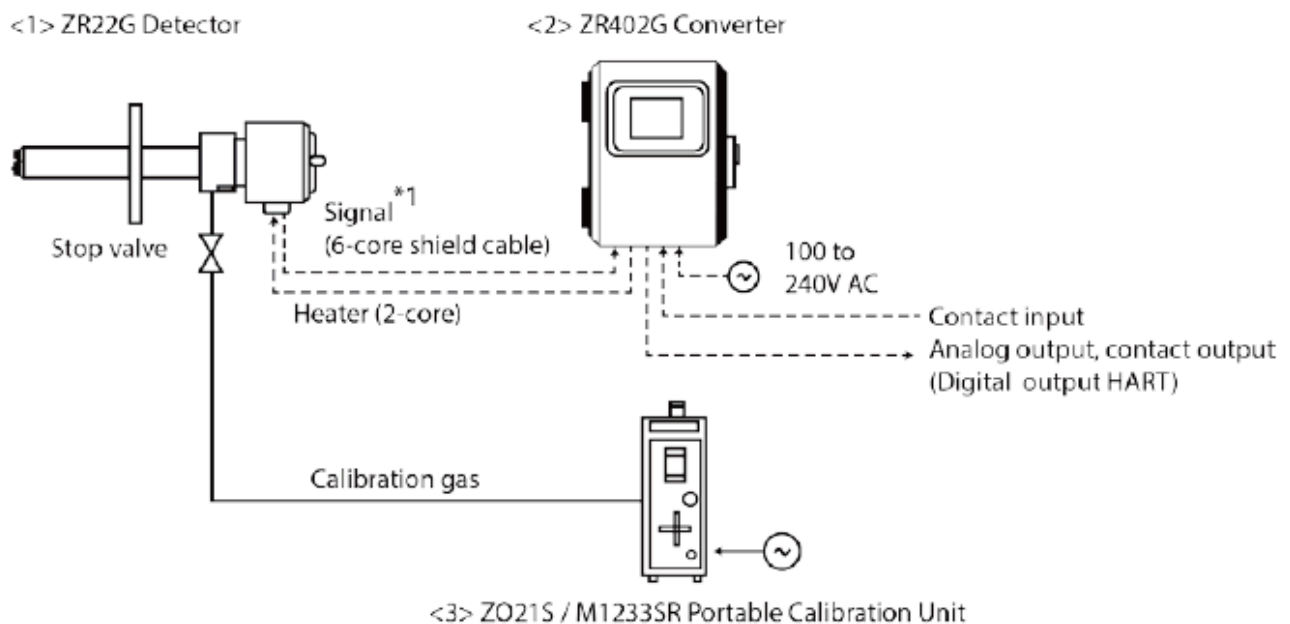

\*1: Shield cable; Use shielded signal cables, and connect the shield to the FG terminal of the converter.

**(2) Type: L2 (manual calibration)**

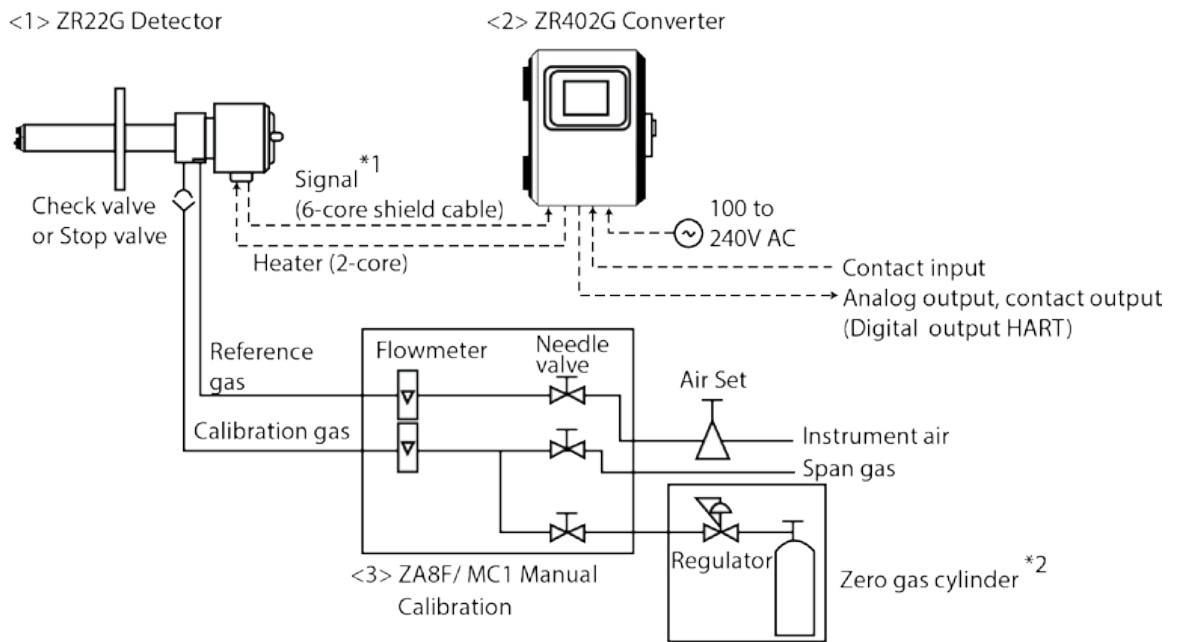

Note: Detector can be selected from among the following

No.	Check	Name	Sketch of shade
1		General-purpose detector (with check valve or stop valve)	 Check valve
2		Detector with probe protector (same as above)	
3		Detector with filter (same as above)	 Dust filter

**(3) Type: L3 (automatic calibration)**

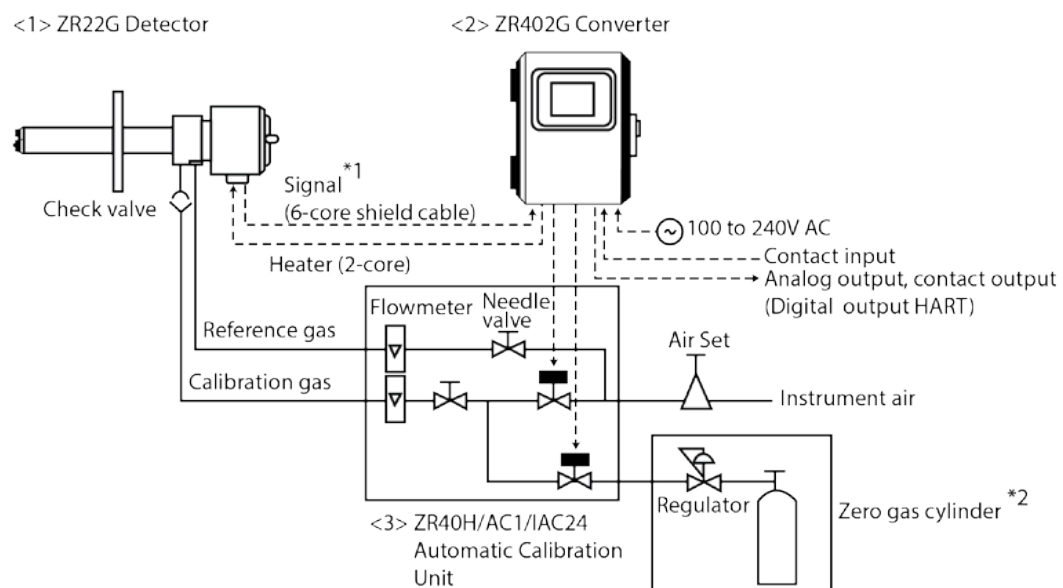

\*1: Shield cable; Use shielded signal cables, and connect the shield to the FG terminal of the converter.

\*2: When a zirconia oxygen analyzer is used, 100% N<sub>2</sub> gas cannot be used as the zero gas. Use approximately 1% of O<sub>2</sub> gas (N<sub>2</sub>-based).

**(4) Type: H1 (simple measurement system)**

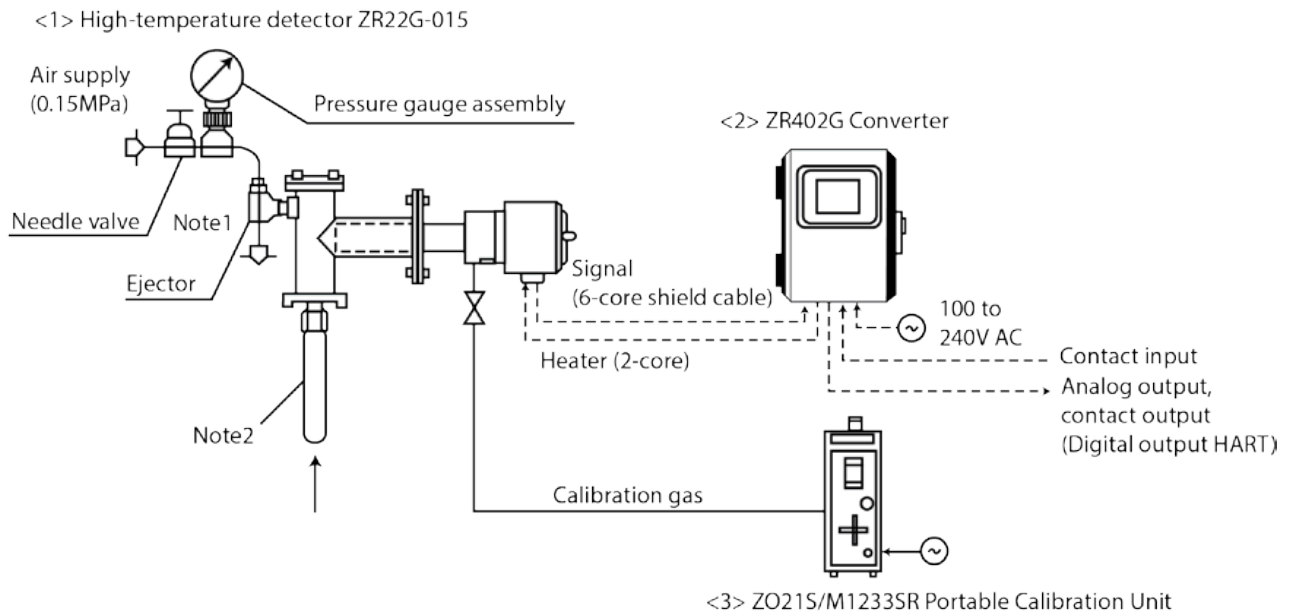

**(5) Type: H2 (manual calibration)**

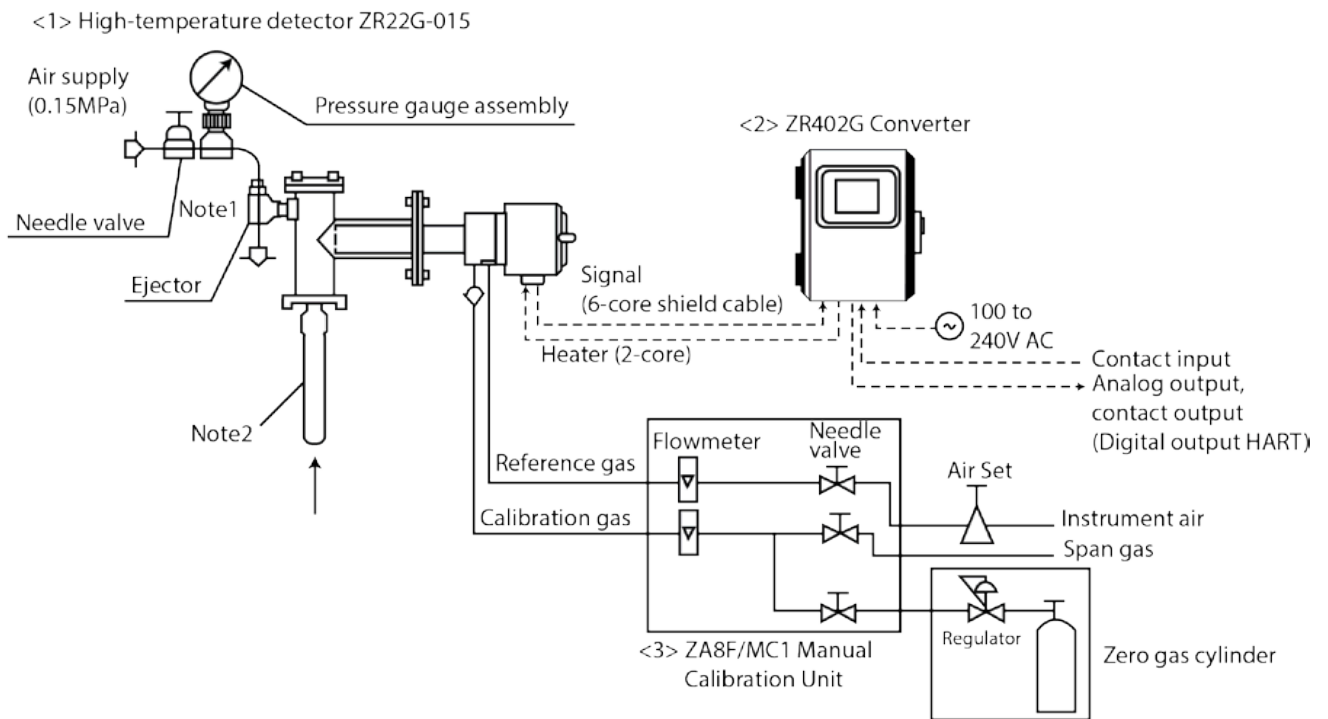

Note 1: Selection of Needle valve or Ejector assembly ● : Necessary

Check	Pressure kPa	Needle valve <sup>1</sup>	Ejector ASSY <sup>2</sup>
	-0.5 or less <sup>3</sup>		
	-0.5 to 0.05		●
	0.05 to 0.5		
	0.05 to 5	●	

Note 2: Selection of high temperature probe material

Check	Mounting orientation	Horizontal mounting	Vertical downward mounting
	Maximum temperature (°C)		
	800	SUS310S	SUS310S
	1400	—	SiC

\*1: G70011XH/G7013XH

\*2: E7046EC/E7046EN

\*3: consult with YOKOGAWA

Note: Ejector assembly consists of Needle valve, Pressure gauge assembly and Ejector.

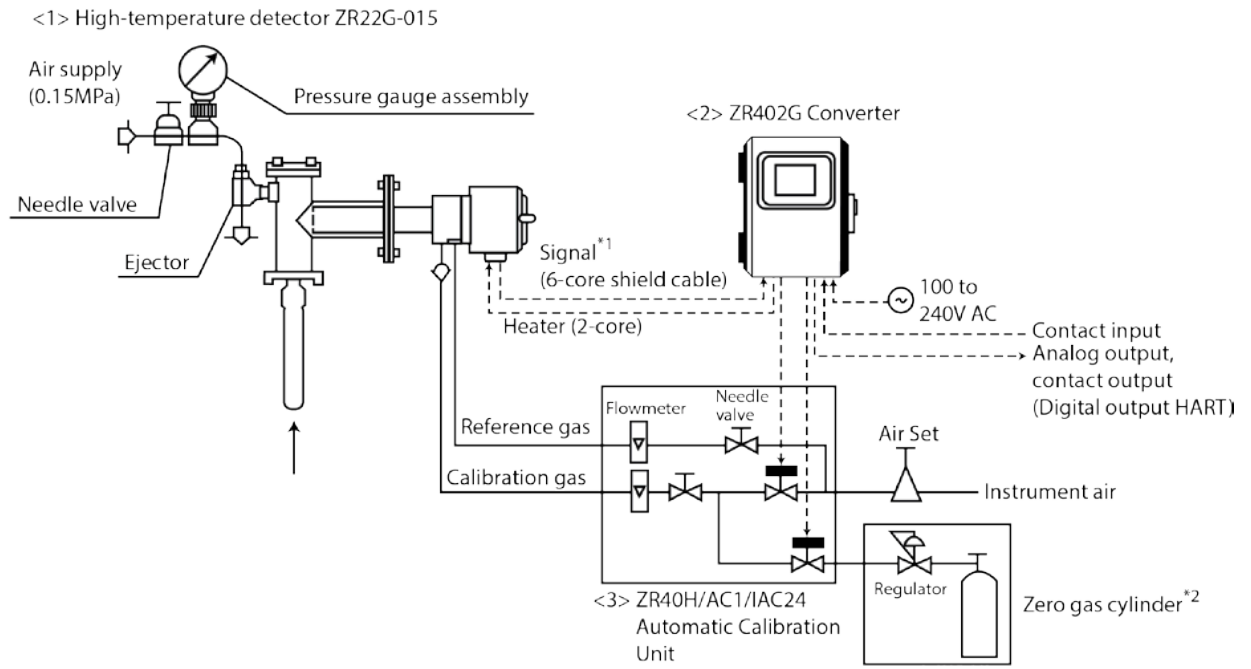

(5) Type: H3 (automatic calibration)



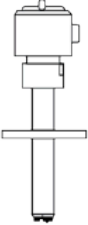
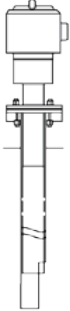
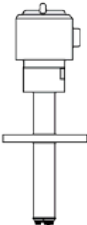

## 6.2.3 Examples of System Component Selection Based on Sample Gas Conditions

### (1) Detector and Accessories

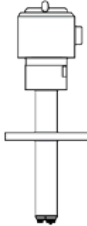
Dust level Pressure		Low (0.5 g/NM <sup>3</sup> or less) -5 to +250 kPa (Note 1)		High (10 g/NM <sup>3</sup> or less)		Remarks
Temperature (°C)	Insertion length	[D1]	[D4]	[D2]	[D3]	
0 to 700	0.4 to 2 m	 <p>General-purpose detector ZR22G</p>	 <p>General-purpose detector ZR22G with probe protector Z021R-L/ZR22R Dust guard protector or Dust filter (Note 2)</p>	 <p>General-purpose detector (Vertical downward mounting)</p>	 <p>(Note) When the probe length is 2 m or more and sample gas contains high level dust, consult us.</p>	<p>(Note 1) When the pressure in the furnace exceeds 3 kPa, is recommended that you compensate the pressure. When the pressure in the furnace exceeds 5 kPa, you must perform pressure compensation. For 0.15 m probe, 0.5 to 5 kPa. No pressure fluctuation in the furnace should be allowed.</p> <p>(Note 2) When dust guard protector (K9471UA) or dust filter (K9471UC) is mounted to the ZR22G of 2 m probe length, consult us.</p>
	2 to 3 m	 <p>General-purpose detector ZR22G</p>				

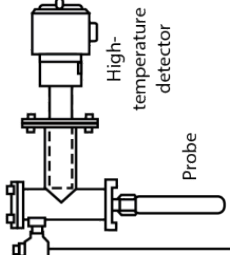
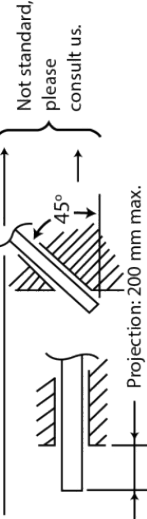
Conditions & specifications	Mounting orientation	Dust level		Low (1 g/Nm <sup>2</sup> or less. Consult us if higher)						Remarks	
		Maximum temperature (°C)	Pressure kPa	-0.5 to +0.05 (note 1)		+0.05 to +0.5		+0.5 to +5			
Temperature (°C)			Probe material	Ejector for probe adapter	Valve	Ejector for probe adapter	Valve	Ejector for probe adapter	Valve		
Over 700 Up to 1400  High-temperature probe adapter  High-temperature detector Probe  Ejector for probe adapter (or needle valve)  ZR22G-015 ZO21P-H/ZR22P (E7046EC or E7046EN)  The high temperature probe adapter includes a standard material probe.	Vertical downward	800	SUS310S	[D5]	Required	Not required	[D6]	Not required	[D7]	(Note 1) Consult us if pressure is less than -0.5 kPa  	
	Vertical downward	1400	SiC								
	Horizontal	800	SUS310S		ZR22G-015 ZO21P-H/ZR22P E7046EC or E7046EN			ZR22G-015 ZO21P-H/ZR22P			ZR22G-015 ZO21P-H/ZR22P  Needle valve not supplied
	Horizontal	1000	Inconel 600								
	Horizontal	over 1000	Not possible								

(2) Converter and accessories (flow setting unit, calibration gas, etc.)

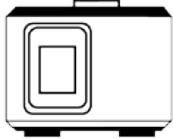
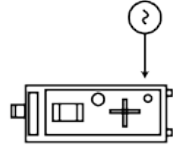
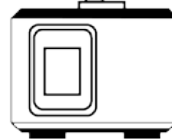
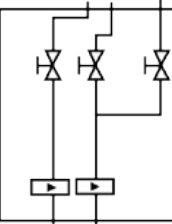
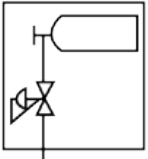
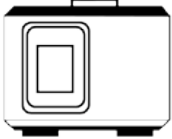
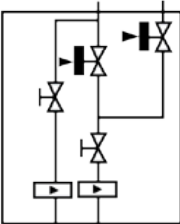
Device Use	Converter	Flow setting unit/ Automatic calibration unit	Calibration gas	Remarks
For monitoring	 <p>ZR402G</p>	None	 <p>ZO21S/M1233SR (standard gas unit)</p>	Minimum configuration for small boiler monitoring, etc.
Control/alarming	 <p>ZR402G</p>	 <p>ZA8F/MC1 (air set not included)</p>	 <p>Cylinder: G7001ZC Regulator: G7014XF G7013XF Case: E7044KF</p>	Most common configuration. Sloenoid valve unit for handling unburnt gas in available as an accessory system for petroleum or petrochemical fired heaters.
General	 <p>ZR402G</p>	 <p>ZR40H/AC1/ IAC24 (air set not included)</p>	Same as above	This configuration automates the calibration operation.
Without automatic calibration				
With automatic calibration				

## 6.3 Compatibility between Old and Existing Models

		Existing Model	Old Model
	Converter		
	Detector	ZR402G	ZA8C, HA400, AV8C
Existing Model	ZR22G	Compatible	Compatible with modifications (Note)
Old Model	Z021D	Compatible	Compatible

Note: Compatibility can be achieved by replacing the ROM and mounting a cold junction temperature compensation board. It is recommended that this modification be requested to our service station. Applicable ROMs and temperature compensation boards will be available on December 1, 2000 for order entry and on January 26, 2001 for shipment. See the table below for ROM part numbers. The part number of a ROM extraction tool is K9471JT, and the part numbers of cold junction temperature compensation boards are K9471JA for the ZA8C and HA400 and K9471JB for the AV8C.

	Language				
Model		Japanese	English	German	French
ZA8C		K9290LF	K9290KF	K9290MF	K9290MG
HA400 (kg)		K9293HT	K9293HU	K9293HW	K9293HV
HA400 (%)		K9293HP	K9293HQ	K9293HS	K9293HR
AV8C		K9296CN	K9296CN	K9296CN	K9296CN

## 7. Basic Steps for Maintenance and Troubleshooting

### 7.1 Maintenance for ZR22 and ZR202

#### 7.1.1 Cleaning the Calibration Gas Tube

The calibration gas, supplied through the calibration gas inlet of the terminal box into the detector, flows through the tube and comes out at the tip of the probe. The tube might become clogged with dust from the sample gas. If you become aware of clogging, such as when a higher pressure is required to achieve a specified flow rate, clean the calibration gas tube.

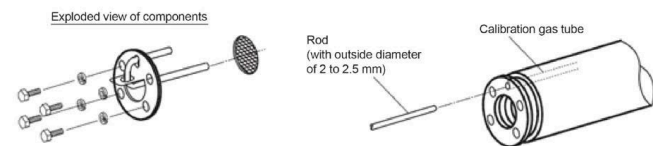

Figure 7.1 Cleaning the Calibration Gas Tube

#### 7.1.2 Replacing the Sensor Assembly

The performance of the sensor (cell) deteriorates as its surface becomes soiled during operation. Therefore, you have to replace the sensor when its life expectancy expires, for example, when it can no longer satisfy a zero correction ratio of  $100 \pm 30\%$  or a span correction ratio of  $0 \pm 18\%$ . In addition, the sensor assembly is to be replaced if it becomes damaged and can no longer operate during measurement.

If the sensor becomes no longer operable (for example, due to breakage), investigate the cause and remedy the problem as much as possible to prevent recurrence.

Please note that it is important that the contact and the metal o-ring are replaced each time the cell is replaced to ensure proper sealing.

- Clean contact spring groove & probe flange.
- Insert new contact spring
- Place Metal o-ring on/between cell and flange
- Insert J-tube into filter retainer.
- Install filter onto J-tube (between cell and retainer)
- Install washers on cell bolts.
- Install cell, retainer, and filter assembly into probe flange.
- Finger tighten all 4 cell bolts
- Tighten all 4 bolts in a criss-cross pattern to 52 in. lbs. (1/8 turn at a time)

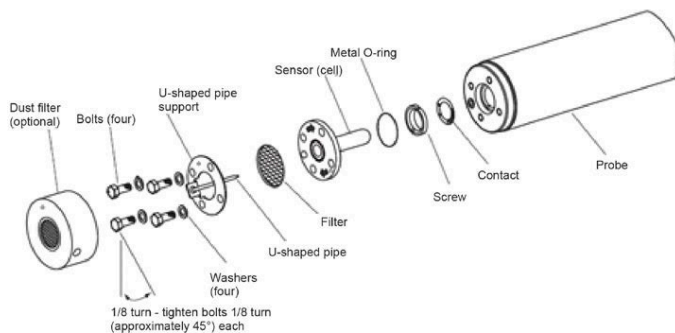

Figure 7.2 Exploded View of Sensor Assembly

### 7.1.3 Replacing the Heater Assembly

Replace the heater assembly when the heater is broken. For more details, please refer IM

### 7.1.4 Replacement of Dust Filter

Set the dust filter in place using a special pin spanner (with a pin 4.5 mm in diameter: part no.K9471UX or equivalent). If a dust filter that has already been replaced once is used again, apply grease (Never-Seez: G7067ZA) to the threads of the dust filter.

### 7.1.5 Replacement of the Fly Ash Filter

- Slide the closed end of the filter shield over the end of the probe approximately 9 inches.

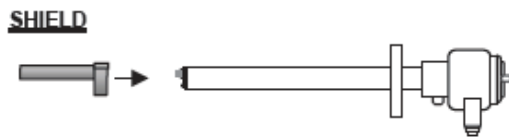

- Slide the filter element over the detector and into the space between the detector and the shield approximately 8 inches. This may be a snug fit, and might require a firm push; however, the filter should not be forced onto the detector.

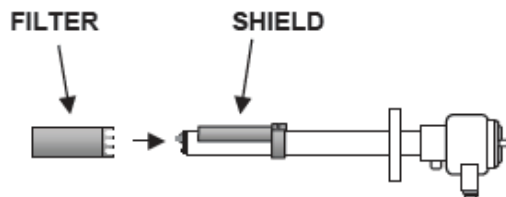

- Slide the end of the shield over the filter

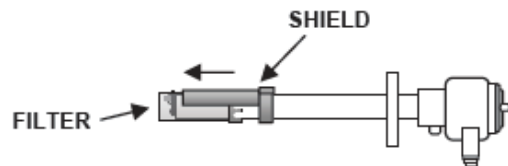

Align the shield so it protects the filter element from direct gas flow. The shield should cover the filter, and be flush with the closed end of the filter, as shown:

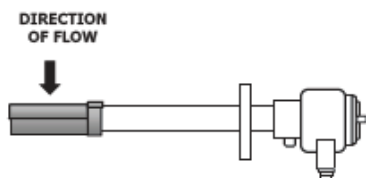

\*NOTE: When using the M1234SE-A Self Cleaning Fly-Ash Filter in conjunction with the ZR22R Probe Protector, repeat the steps above, but invert the M1234SE-A shield away from the direction of flow.

- Tighten the clamp screw until the filter cannot be moved by hand. The filter will be fully tightened before the space between clamp block is completely

closed. THE SCREW SHOULD NOT BE TIGHTENED BEYOND THIS POINT. Over tightening the assembly can damage the detector and filter.



### 7.1.6 Replacement of O-ring

The detector uses three different types of O-rings. (For a pressure compensating model, two O-rings are used for individual uses. Two O-rings are used for reference gas sealing and require periodic replacement. For more details, please refer to the IM.

## 7.2 Calibration

There are 3 modes of calibration:

- Manual calibration: You manually step through the calibration. This mode allows you to change
- Semi-auto calibration: This mode is a "one touch" calibration mode. In the semi-auto calibration mode you just start the calibration and it does everything else. You have to set the calibration, hold times, calibration gas values previous to using this mode.
- Auto-Calibration: You set the start date, time, frequency, calibration time, hold times and the analyzer does calibration on its own.

It is important to note that before you can run automatic calibration or semi-automatic calibration, you have to configure the calibration setup for the Hold time and Calibration time in the instruments before you can run a semi-auto or an auto-cal.

- Hold Time: The time you want the probe to hold before it releases the current output. (so the calibration gas can clear the probe and be back to process measurement)
- Calibration time: Set this to allow ample time for the calibration gas to flow from the calibration system to the probe and stabilize

All of the calibration modes output calibration signals through the calibration contacts and send the output thru relay contacts.

### 7.2.1 Best Practices for Calibration

When performing a calibration it is important that you:

- Wait minimum 1 hour after powering a probe up to calibrate.
- Calibration gas flow should never exceed 600 cc/min (0.6 l/min).
- Clean/Dry instrument air is used as the typical span gas.
- Zero gas should be between .01-4% oxygen balance nitrogen. Do not use mix bottles or 100% nitrogen for zero calibration. (1% and 2% are the 2 most common used gases)
- Use ZR20-CAL or equivalent gas bottle which includes regulator and flow control (0.5 l/min)
- Calibration should be performed at operating conditions.
- When you calibrate the Zirconia outside the furnace, you need to use only one standard gas and use ambient air as second gas. The concentration depends on humidity and temperature: typically 20.5 vol%.
- If the furnace operates under pressure different from atmosphere you make an error on reading that is the same as the relative pressure difference. (-20 mbar = -2% of reading).

### 7.2.2 Calibration of the Humidity Analyzer

The Humidity analyzer cannot be calibrated with Humidity standards, but will be calibrated as every other Zirconia analyzer with a 1% Oxygen in Nitrogen standard gas and with dry instrument air as second standard.

## 7.3 Trouble Shooting

When troubleshooting it is important to know and understand the following because 90% of the problems are solved without soldering , adjustment or initialization.

- Ask the questions
  - Problem description?
  - Serial number, Software revision
  - Known or New problem?
  - Old or New installation?
  - Process conditions ( Pressure, Temperature, Flow rate, Dust/Solids concentration, Process composition)
  - Display reading? before and after running defaults
  - Diagnostic information? before and after running defaults
- Understand the application
- Understand the installation
- Understand the customers' expectations
- Analyze the problem or complaint.

Anytime there is a failure on the AV550 or the ZR402 the units will shut the probe heater down immediately. These failures will show an X on the ZR402/AV550 screens.

Things that cause a failure:

- Cell voltage goes outside limits (excessive high or low)
- Heater goes below 730°C or above 780°C
- CPU/Eprom function failure
- Zero calibration failure
- Span calibration failure

Please note that when testing your system it is always good practice to start with any tests that can be performed in the analyzer. If the analyzer tests fine then check the probe next. If the probe test good then you know the cable is bad and should be replaced. Also when turning power off to the analyzers it is never recommended to use the fuses. Always use either the electronics or a breaker. Using the fuses could cause a short in the instrument.

### 7.3.1 Error and Alarm

When the display shown in Figure 7.3 or Figure 7.4 appears, pressing the error indication brings up a description of the error. The content of errors that are displayed includes those shown in Table 7.1.

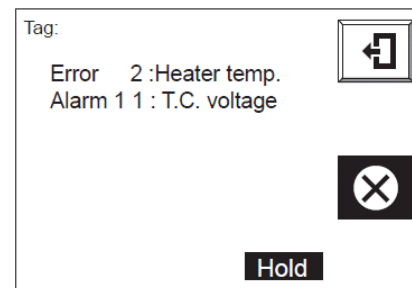
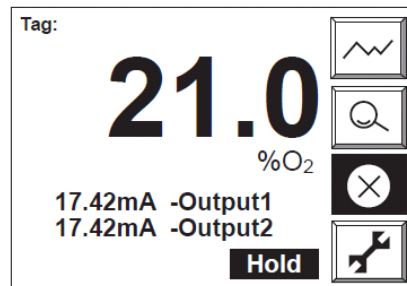

Figure 7.3 Display on ZR402G

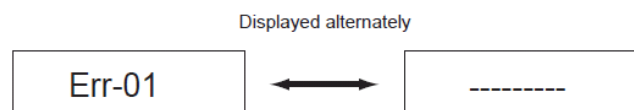

Figure 7.4 Display on ZR202

Table 7.1

Error Code	Error Type	Occurrence Conditions
Error1	Cell voltage failure	The cell (sensor) voltage signal input to the converter falls below -50 mV.
Error2	Heater temperature failure	The heater temperature does not rise during failure warm-up, or it falls below 730°C or exceeds 780°C after warm-up is completed. Or this occurs if the TC+, TC- thermocouple terminals are wired to converter with reverse (wrong) polarity.
Error3	A/D converter failure	The A/D converter fails in the internal electrical circuit in the converter.
Error4	Memory failure	Data properly are not written into memory in the internal electrical circuit in the converter.

When an alarm is generated, the alarm indication blinks in the display to notify of the alarm. Pressing the alarm indication displays a description of the alarm.

Alarms include those shown in Table 7.2. If an alarm is generated, actions such as turning off the heater power are not carried out. The alarm is canceled when the cause of the alarm is removed.

Table 7.2 Types of Alarms and Reasons for Occurrence

Alarm Code	Alarm Type	Occurrence Conditions
Alarm 1	Oxygen concentration alarm	Measured oxygen concentration value exceeds or falls below the preset alarm limits.
Alarm 6	Span-point calibration coefficient alarm	In automatic or semi-automatic calibration, zero correction ratio is outside the range of $100 \pm 30\%$ .
Alarm 7	Span-point calibration coefficient alarm	Span correction ratio is outside the range of $0 \pm 18\%$
Alarm 8	EMF stabilization timeup alarm	In automatic or semi-automatic calibration, cell voltage does not stabilize after calibration time is up.
Alarm 10	Cold junction temperature alarm	Temperature of the cold junction placed in the detector terminal box falls below $-25^{\circ}\text{C}$ or exceeds $155^{\circ}\text{C}$ .
Alarm 11	Thermocouple voltage alarm	Generated when thermocouple voltage exceeds 42.1 mV (about $1020^{\circ}\text{C}$ ) or falls below -5 mV (about $-170^{\circ}\text{C}$ ).
Alarm 13	Battery low alarm	Internal battery needs replacement.

### 7.3.2 Basic Zirconia Probe Check

Ohm Meter Checks:

- Heater : 57-85Ω (typical is 62-67Ω).
- Typical failure is Open or shorted
- TC : if the probe is on the bench less than 3Ω, in the stack and hot less than 100Ω(it is a type K TC)
- Typical failure is open or short to the case.
- Cell negative wire to the case. It should be a direct short to the case.
- Failure would be above 5Ω or intermittent/erratic readings.

Cold junctions:

- RTD type (red/black or red/white wire) approx 1100Ω, no polarity (2 wire PT1000 RTD) .
- Typical failure is Open or shorted.
- Transistor type (silicon mushroom cap with 2 wires and a metal table to one side, and a single wire to

the other) checks out like a diode. One direction is high resistance (typically in the MΩ) then the other direction will be open.

- Typical failure will have resistance both directions or short.

500Vdc Insulation Meter Checks (Aka: Megger/ Insulation Tester):

Be sure there are no wires attached to probe before doing this test. The unit must be disconnected from the cable and analyzer.

- TC + to the case. Should be 20M+
- TC - to the case. Should be 20M+
- Cold Junction + to the case. Should be 20M+
- Cold Junction - to the case. Should be 20M+
- Both sides of the heater to the case. Should be 20M+

## Additional Checks:

- If you have the O<sub>2</sub> cell out of the probe you can check the Cell+ wire using an ohm meter. Measure between the Cell+ terminal and the groove where the contact spring is. The reading should be less than 3 ohms.
- With the O<sub>2</sub> cell out you can also check the Cell+ to case/ground using a 500 Vdc Megger. The reading should be 20M+.
- You can check the Cell- wire inside the probe head, make sure cell- is connected the body of the probe. Should be less than 3 ohms (this is testing the short brown-ish wire that runs from the cell- to the case).
- If you have the cell out you can pressure test the calibration line. Flip the O<sub>2</sub> cell over and put a piece of rubber between the cell flange and calibration line outlet. Then connect a pressure gauge to the calibration line input, apply a couple PSI to the line, shut the inlet pressure off, the calibration line should hold the line pressure for 5-10 minutes easily

### 7.3.3 Testing O<sub>2</sub> Cell

The base test procedure for testing an O<sub>2</sub> cell is as follows:

- Turn the power off to the analyzer
- Remove the cell + & - wires from the analyzer/channel card.
- Place a short between the Cell + & - on the analyzer/channel card.
- Apply power the analyzer. The unit should warm up without error. If the unit comes up with a cell failure the electronics/channel card is bad.
- Connect a millivolt meter to the 2 wires you just removed.
- Apply Zero and/or Span calibration gas (500 cc/Min). Measure the loose wires at the electronics.
  - Span Gas (instrument Air) should read close to 0mV (+/- 5 mV)
  - Zero Gas Should read as follows:
    - 0.4% O<sub>2</sub> – 84 mV's (75-90 mV's)
    - 1% O<sub>2</sub> – 67 mV (55-70 mV's)
    - 2% O<sub>2</sub> – 52 mV's (45-55 mV's)

*\*Please note that the different ranges are given to accommodate for negative or positive process pressure\**
- If the voltages are not stable or not within those ranges go to the back of the ZR22G and remove the Cell + and Cell – wires from the probe.
- Then apply both gases again and measure the millivolts on the ZR22G terminal Cell + and Cell –. If the signals are correct there but not at the electronics, you have a problem with your cable. If the signals are not correct at the back of the probe you most likely have a broken/damaged O<sub>2</sub> cell.

### 7.3.4 My detector is reading a high O<sub>2</sub> level

- **The measuring gas pressure becomes higher:**

When the process pressure increases the oxygen reading will be higher. Certain steps should be taken to ensure a proper measurement.

  - Can improvement in facility be made so that pressure change does not occur?
  - Can the probe be calibrated at process pressure?
  - Change the Oxygen Probe to a Pressure compensating model
- **Moisture content in a reference gas changes (increases) greatly:**

If ambient air at the detector installation site is used for the reference gas (convection sourced), a large change of moisture in the air may cause an error in measured oxygen concentration value (vol% O<sub>2</sub>). When this is the case, use a gas in which moisture content is constant such as a clean dry instrument air or a bottled gas source such as a 21% O<sub>2</sub> balanced in Nitrogen.
- **Calibration gas (span gas) is mixing into the cell due to leakage:**

If the span gas is mixing into the cell due to leakage as a result of failure of the valve in the calibration gas tubing system, the measured value shows a value higher than normal. Check valves (needle valves, check valves, solenoid valves for automatic calibration, etc.) in the calibration gas tubing system for leakage. For manual valves, check them after confirming that they are in fully closed states. In addition, check the tubing joints for leakage. Plug off calibration line at the back of probe. If problem goes away find the leak in the calibration system.
- **The reference gas is mixing into the process gas and vice versa:**

Since the difference between oxygen partial pressures on the cell anode and cathode sides becomes smaller, the measured value shows a higher value. Process gas and/or the reference gas may be leaking. Visually inspect the cell. If any crack is found, replace the cell assembly with a new one.
- **Cracked O<sub>2</sub> cell:**

To test run calibration, apply zero gas at 500cc/min max. See if reading is stable and correct, if not stable or it is reading high it is likely the cell is cracked. If the cell is leaking then you will start to see the O<sub>2</sub> level climb. The time before you see this climb depends on the distance from the gas source, it could take 15-30 min.
- **Damaged calibration line/Manifold:**

Remove O<sub>2</sub> cell. Plug end of calibration line (You can flip the O<sub>2</sub> cell over, place a small piece of rubber in between the cell and flange and install the cell to plug off the line). Apply a approximately 1 PSI to the calibration line, shut the pressure off and see if it holds pressure.



- **If using the High Temp Tee:**
  - The Eductor (Ejector) could be Plugged therefore needs cleaning or replacement.
  - The Eductor (Ejector instrument air pressure could be set to low. –Verify air pressure is set high enough

### 7.3.5 My detector is reading a low O<sub>2</sub> level

- **The measuring gas pressure becomes lower.**  
When the process pressure decreases, the oxygen reading will be lower. Certain steps should be taken to ensure a proper measurement.
  - Can improvement in facility be made so that pressure change does not occur?
  - Can the probe be calibrated at process pressure?
  - Change the Oxygen Probe to a Pressure compensating model
- **Moisture content in a reference gas changes (decreases) greatly.**  
If ambient air at the detector installation site is used for the reference gas (convection sourced), a large change of moisture in the air may cause an error in measured oxygen concentration value (vol% O<sub>2</sub>). When this is the case, use a gas in which moisture content is constant such as a clean dry instrument air or a bottled gas source such as a 21% O<sub>2</sub> balanced in Nitrogen.
- **Calibration gas (zero gas) is mixed into the cell due to leakage.**  
If the zero gas is mixed into the detector due to leakage as a result of failure of the valve provided in the calibration gas tubing system, the measured value shows a value lower than normal. Check valves (needle valves, check valves, solenoid valves for automatic calibration, etc.) in the calibration gas tubing system for leakage. For manual valves, check them after confirming that they are in fully closed states.
- **Combustible components exist in the measured gas.**  
Clogging at the cell can occur if residual combustibles are present (carbon build up). If combustible components exist in the measured gas, they burn in the cell and thus oxygen concentration decreases. Remove the probe and clean the cell. Check that there are no combustible components.
- **Bad O<sub>2</sub> cell:**  
Run calibration. If cell resistance is above 200Ω replace the cell.
- **Leak in calibration system (zero gas):**  
Plug off calibration line at the back of probe. If problem goes away find the leak in the zero calibration gas side of the calibration system.
- **Excess hydrocarbons:**  
O<sub>2</sub> probes control at 750°C, If the process has excessive hydrocarbons (un-burnt fuel) they can burn on the tip of the probe consuming the oxygen at the tip of the probe and making the reading go low.

- **Excess moisture in process:**  
If excessive moisture is in the process it can come in contact with the O<sub>2</sub> probe (750°C) and cause steam right at the O<sub>2</sub> cell. If you have excessive steam at the O<sub>2</sub> cell it will read low, as well as possibly damage the O<sub>2</sub> cell.
- **If using the High Temp Tee:**
  - The Eductor (Ejector) could be Plugged therefore needs cleaning or replacement.
  - The Eductor (Ejector instrument air pressure could be set to low. –Verify air pressure is set high enough

### 7.3.6 Other Abnormal Values

- Noise may be mixing in with the converter from the detector output wiring.
  - Check whether the equipment is securely grounded.
  - Check whether or not the signal wiring is laid along heater cables or other power cords.
- The converter may be affected by noise from the power supply.
- Check whether or not the converter power is supplied from the same outlet, switch, or breaker as other power machines and equipment.

### 7.3.7 Experiencing Erratic Reading

- Be sure heater and signal wires are in separate conduits.
- Flow zero gas at 300-500 cc/min on probe. If reading continually drifts up the O<sub>2</sub> cell is cracked.
- Perform a calibration
  - If readings are unstable and calibration fails see cell troubleshooting.
  - If unit calibrates correctly the problem is outside of the probe.
- Possible causes of erratic readings outside the probe:
  - Excess moisture in high temp tee (or condensing moisture in process)
  - Pockets of un-burnt hydrocarbons in process (this will cause low spikes)
  - Turbulence in process flow (turbulent pressure)

### 7.3.8 Probe Temperature low and not warming up

- On an AV550 If the probe fails to warm up turn off and reset the channel. On the ZR402G recycle the power to the analyzer.
- Unwire the Heater, TC, and CJ and perform the ohm meter check on the Heater, TC, and CJ.

If you find a failure in one of the above, go to the back of the probe and check them inside the probe housing. If there is not failure in the probe housing, but there is one at the electronics the problem is in the cable. Therefore if all the values check out in the probe then you need to check out the electronics.

- Reconnect the wires from the heater, TC, and CJ.
- Then reset the analyzer/channel, measure the voltage going to the heater. It should be 60-120Vac (Voltage is a modulated voltage but can be measured as AC)
- If power is not present check the fuses. On the AV550 they are on the power unit (just above where the heater wires up). There are 2 fuses per channel. On the ZR402G they are on the board.

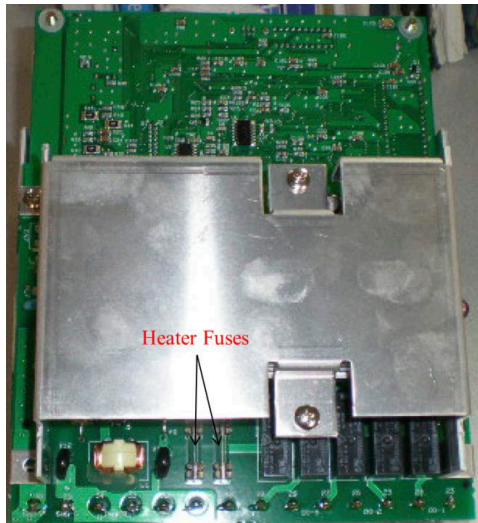

ZR402G

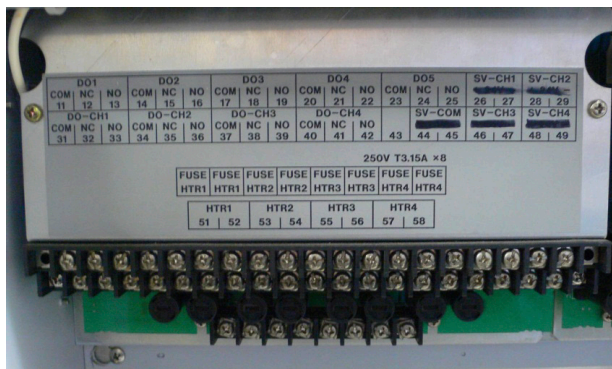

AV550G

### 7.3.9 Probe Temperature Too High

This is for if your probe starts up and it goes to 780°C and shuts down

- Check your wiring. Make sure AC power is not wired directly to the heater.
- Check to be sure both heater wires are running up to the heater (the heater is a floating ground heater and should not be grounded anywhere)
- Do the base ohm/megger checks.

#### ZR402G

Measure the heater voltage as the probe warms up. You should see the heater voltage change and attempt to regulate above 730°C. If the voltage does not change until it hits 780°C the electronic control circuit is damaged.

#### AV550

- Be sure that the heater and signal cables are landed on the correct card/heater connection. If a pair of heaters is criss-crossed it can cause this.
- On an AV550 try swapping a working channel card with the channel in question. If a different card works properly it is a bad channel card.
- Swap probe to a working channel. If it works on a new channel and not on the old channel the power unit is damaged.

### 7.3.10 High Impedance Reading (Zirconia cell & contact resistance & lead resistance)

- Zirconia cell chemically attacked
- Zirconia cell broken
- Contact spring corroded
- Spring groove corroded
- Platinum wire between flange and cell damaged

### 7.3.11 Short Sensor Life

- Corrosion by flue gas
  - Check for dust in sensor
  - If dust is found, then burning dust corrodes sensor surface: Platinum peels off
  - Then use probe protector or probe adapter
  - Flyash filter will also improve lifetime.
- Problem can be caused by corrosion of contact spring and contact groove. Corrective action is to polish groove and replace spring every time sensor is replaced.

### 7.3.12 Short Heater Life

- Heater life is determined by number of start-up's rather than service life.
- Use step-down transformer if frequent start-up cannot be avoided.
- 230 VAC is more burdening the heater than 100 VAC by high peak voltages during start-up.
- If heater life is too short and there is no visible corrosion, then please report. We may get you free replacement.

### 7.3.13 Automatic Calibration Panel, Model AC8

If your AC8 solenoids all fail to work but work in manual mode check the fuses. Also check to be sure there is a Jumper from the PS to PS terminals.

## 8. Zirconia Analyzer – Question & Answers

### 8.1 Application

*Q1. When to select Zirconia principle for measuring Oxygen?*

A1. Zirconia is the measurement of choice when direct measurement without sampling system is used with a high speed of response for process control. The most common application is for combustion control of boilers, heaters or furnaces. Also for the indirect measurement of moisture in air-water vapour mixtures in applications where high temperatures and dirty environment prevent the use of traditional moisture analyzers.

*Q2. When Zirconia Principle cannot be used?*

A2. Zirconia uses a sensor at high temperatures and Platinum electrodes. Therefore the Zirconia cannot be used in applications where Hydrocarbons are present or possible. These Hydrocarbons react with Oxygen at the sensor surface and this causes measuring errors ( low readings) and in worst case explosions: The sensor acts then as an ignition source: for explosions you need Fuel, Oxygen and Ignition. This makes a Zirconia analyzer a hazard in any gas fired furnace or heater during start-up conditions or shut down conditions, when explosive gas mixtures can occur in the furnace or heater. Only when safety devices are used that purge the sensor and shut off the power to the heater during these hazardous conditions the Zirconia analyzer can be used safely. The flame arrester used in the ZR22S and ZR20S only offer some added safety when the sample gas is within the ambient temperature limits of the product ( max 55 or 60°C)

*Q3. Why is CO Analyzer needed for combustion measurement?*

A3. Every combustion process is performed with an excess of air. This is necessary because burners are not ideal and cannot operate purely under stoichiometric conditions. The excess air may not be too high, because then efficiency of the burner drops and pollution will result from the formation of Nitrous oxides. The only method to be sure that the burners operate at optimal condition is to monitor the CO concentration. If the excess air ratio is too low, CO concentrations will rise.

Our Laser Analyzer model TDLS8000 can measure CO very accurately at combustion zone where it is to be measured

*Q4. What happens if sample gas contains corrosive gases like HCl, SO<sub>2</sub>, SO<sub>3</sub>, H<sub>2</sub>S, Cl<sub>2</sub>, NH<sub>3</sub>?*

A4. Generally these gases are to be avoided since these react with Zirconia element & attack the Platinum electrode which will lead to erroneous readings, large zero/ span drift, long response time.

Our Zirconia sensor has much resistance to the above gases compared to our competitors & also have special alumina coated Platinum electrode. We can handle SO<sub>2</sub> – 5000 PPM, NO-1000 ppm, HCL 50 PPM. Corrosion from SO<sub>2</sub> will be more severe when the Oxygen concentration is low. Combustion of low quality fuel ( high Sulphur) will shorten the lifetime of the sensors

Special care need to be taken for Incinerators as they may have high amount of these unwanted gases! In these applications often high concentrations of HCl are present in the flue gas together with high water concentrations. This does not only shortens the lifetime of the sensor, but condensation on the detector surface causes corrosion of the Stainless Steel body. Application of a corrosion protection like a coating of Derakane on the detector are a good solution for these application.

*Q5. What happens if sample contains combustible gases like Hydrogen, CO or Methane ?*

A5. The oxygen concentration to be measured decreases! When we look at these examples we can roughly calculate the measuring errors when these gases react with Oxygen on the surface of the sensor:

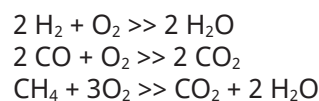

So when the Oxygen concentration is 3 vol% and the concentration of CO is 1 vol%, then the reading will be  $3 - 0.5 \cdot 1 = 2.5 \%$ . The error is  $-0.5 \text{ vol}\%$

If the concentration of Methane is 1 vol% then the reading will be  $3 - 3 \cdot 1 = 0 \text{ vol}\%$  Here the error is  $-3 \text{ vol}\%$

This is a simplified explanation, because diffusion rate of the gases is also important and this makes the measuring errors in presence of Hydrogen much more severe.

*Q6. Till what sample temperature Zirconia probe can be used ?*

A6. Sample temperature can be up to 700°C for normal configuration of probe. The sensor temperature is controlled at 750°C, so the sample gas must be lower. Otherwise an accurate temperature control of

the sensor is not possible. At high temperatures the Stainless Steel will also show increased corrosion, so the normal detector can be used till 600°C where between 600 and 700°C the use of Inconel mounting screws is recommended. The ZR22S and ZR202S use flame arresters of sintered stainless steel so they should not be used at temperatures above 500 degrees to avoid blockage of flame arrester by corrosion. When using Zirconia Oxygen Analyzer, what kind of matters that require attention (effects of flammable gas) are there?

The sensor (zirconia element) is heated to 750°C during measurements. If the process gas contains combustible gases such as carbon monoxide, hydrogen, and methane, these gases burn in the detector and consume oxygen, causing the oxygen concentration measured by the oxygen analyzer to be smaller than the actual value. Therefore, zirconia oxygen analyzers should be used only when the effect of coexisting combustible gases can be ignored or when their effect on oxygen concentration can be corrected.

Generally, exhaust gases after combustion that are emitted from combustion equipment such as boilers and industrial furnaces have been completely burned; the volume of combustible gases such as carbon monoxide is very small in comparison with oxygen, and so their influence can be ignored. However, if the excess air ratio is extremely small or if combustion is non-uniform, causing carbon monoxide to be produced, care is required.

*Q7. How does the humidity in reference gas (air) influence it?*

A7. Zirconia oxygen analyzers use a gas whose oxygen concentration is known and always consistent, as the reference gas.

In general, air is used as the reference gas. The oxygen concentration of dry air is constant at 20.95%; however, air generally contains water vapor, in which case the oxygen concentration varies with temperature and humidity. For example at ambient temperature of 40°C and 100 % relative humidity the Oxygen reference concentration is only 19 vol%.

In zirconia oxygen analyzers, a measurement error is caused if the temperature or humidity of the reference gas (air) varies significantly between calibration and measurement. If the analyzer is calibrated with instrument air as reference and installed with ambient air natural convection configuration the Oxygen readings will read  $(21-19)/19 = 10$  rel% too low. When instrument air is used as the reference gas, this error can be ignored, but if it cannot be used, care is required.

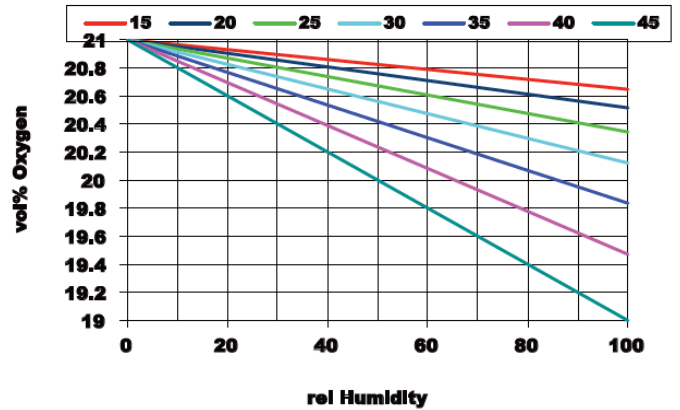

*Q8. Pressure compensation function*

A8. If the in-furnace pressure is high or there are variations in the in-furnace pressure, the pressure balance between the inside of the furnace and the reference air is lost, making it difficult to measure the oxygen concentration accurately. The Zirconia analyzer does not measure the Oxygen concentration, but the partial pressure of Oxygen. If the pressure on both sides of the sensor is equal, then we can simply calculate the concentration from the output voltage of the sensor. If the pressure in the furnace is -100 mbarg, then the measurement will read 10 rel% too low, if the analyzer is calibrated when there was no pressure difference. For example when the analyzer is calibrated in the workshop. If the pressure in the process fluctuates and is causing errors that are unacceptable for the user the detector's pressure compensation function can be used to return the reference air to the furnace to maintain the pressure balance between the inside of the furnace and the reference air side. This enables reliable measurements to be made. This function allows in-furnace pressures of up to 250 kPa to be measured.

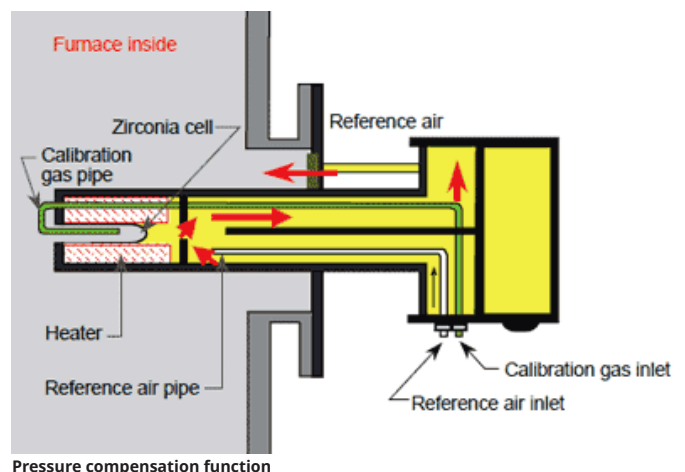

It is very important that a check valve is mounted in the pressure return line. Otherwise there is a risk of blow back, when the reference air supply fails or when

there is some leak like improperly sealed cover or cable glands: the over pressure will cause the sample gas to enter the detector and as result the readings will be wrong ( much too high) and the detector internal components will be severely attacked by the hot flue gas.

## 8.2 Installation

*Q1. Where to install the Oxygen probe?*

A1. If Oxygen reading is used for Trimming control, location close to the combustion zone is desirable, but the temperature & oxygen concentration distribution should also be considered. Better to go with customer recommendation on the location. Important is to install the Oxygen probe at a location that the dirty fluegas cannot come in contact with the Zirconia sensor. Probe protectors, probe adapters, filters and generally vertical mounting are possibilities to improve the situation. Make sure that regardless of the selected detector model the access hole for the Oxygen probe is always 65 mm diameter or more.

*Q2. How far can the converter be located from the detector?*

A2. It depends on the size of the wire the distance to be limited to the loop resistance of the wire does not exceed 10 ohms. Rule of thumb is if the wire is 2 sq mm – can go up to 500 meters

## 8.3 Maintenance

*Q1. How often Calibration is required?*

A1. Typical interval is 1 to 3 months depending on the application, It is recommended to do the calibration every 2 weeks immediately after new installation. When this shows that the sensor does not drift in this application the period can be extended. If the sensor drifts in between these calibration intervals the installation must be reviewed carefully to improve the performance. Sensors are expensive, so the user needs to pay attention to a proper installation to get good performance and low cost of ownership.

*Q2. How can I clean the fly ash filter M1234SE-A?*

A2. They can remove the filter and use water and vinegar to clean the filter. Allow it to dry completely before returning it to the probe.

*Q3. How long will the Zirconia cell last?*

A3. A typical lifetime for a Zirconia sensor is 3 years depending on the gas composition of the sample and the quality of the installation. After each 2-point

calibration, the cell expected life time is displayed in the display. Points of consideration are cell resistance, zero and span ratio and in case of autocal installations: response time.

*Q4. How to know the cell is no longer functional?*

A4. Cell robustness value after every calibration can indicate the cell life! The cell response time during calibration also slows down if the cell is deteriorating provided the calibration gas path etc is taken into account for the response time ! In worst case the sensor will show E1 error message and this indicates either that the sensor is broken or that the sensor is corroded so badly that the calibration cannot be successfully performed.

*Q5. Explain the precautions when shutting down a furnace or boiler.*

A5. If operation of the zirconia oxygen analyzer is stopped during plant shutdown, moisture may condense on the detector's probe in contact with gas, causing dust to adhere to it. If operation is restarted in this condition, dust on the sensor will become firmly adhered and severely affect its performance. In addition, if condensed water accumulates, the sensor may be broken by heat shock, making the analyzer unusable.

When stopping the zirconia oxygen analyzer, it is important to do the following:

- Keep on supplying power to the zirconia oxygen analyzer.
- Purge the sensor by a continuous flow of instrument air through the calibration pipe.
- If it is impossible to keep on supplying power to the analyzer remove the detector from the system.
- If the process is shut off and the gas is non corrosive ambient air, then you can keep the detector without power and purged with instrument air: both cal gas and ref gas connection.

Note: If the process is running, but the Zirconia analyzer is not kept under power, then condensation on the detector may seriously corrode the detector, even if the cal and ref connections are purged.

Never connect power to the analyzer before the calibration pipe and sensor are properly purged

*Q6. Notes for when running and stopping the analyzer repeatedly on a regular basis*

A6. From previous question it is clear that frequent running and stopping of the Zirconia analyzer is not good for good performance. Condensation and corrosion can damage the Oxygen probe. Also frequent start-up of the heater shortens the lifetime of the

heater. If unavoidable, then the user should install a step-down transformer if the power supply is 220- 240 Volt-AC. The power supply range of the analyzer is 85 to 276 VAC and in this abnormal situation it is best to keep the power supply voltage low.

**Q7. Overview of the calibration of zirconia oxygen analyzer**

A7. The electromotive force E (mV) is given by Nernst's equation. The following figure shows the relation of oxygen concentration and sensor (cell) electromotive forces, when the zirconia element is heated up to 750°C.

The measurement principles of a zirconia oxygen analyzer have been described below. However, the relationship between oxygen concentration and the electromotive force of a cell is only theoretical. Usually, in practice, a sensor shows a slight deviation from the theoretical value. This is the reason why calibration is necessary. To meet this requirement, an analyzer calibration is conducted so that a calibration curve is obtained, which corrects the deviation from the theoretical cell electromotive force.

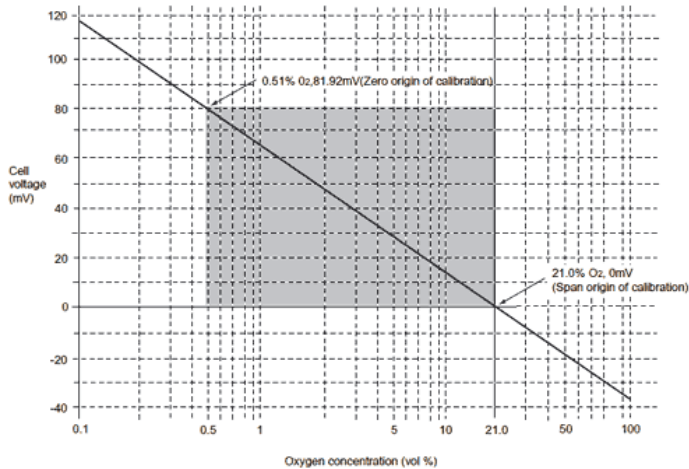

Oxygen concentration in a Measurement Gas vs Cell Voltage (21% O2 Equivalent)

**Q8. What gas is used for calibration?**

A8. A gas with a known oxygen concentration is used for calibration. Normal calibration is performed using two different gases: a "zero gas" of low oxygen concentration and a "span gas" of high oxygen concentration (two-point calibration). In some cases, only one of the gases needs to be used for calibration. However, even if only one of the gases is normally used, calibration using both gases should be done at least once.

The zero gas normally used has an oxygen concentration of 0.95 to 1.0 vol%O<sub>2</sub> with a balance of nitrogen gas (N<sub>2</sub>). The span gas widely used is clean air (at a dew-point temperature below -20°C and free of oily mist or dust, as in instrument air).

The concentration of the Zero gas can be anywhere between 0.3 and 100 vol% and the concentration of the span gas can be set anywhere between 4.5 and 100% under the condition that the Oxygen concentration in the span gas is at least 10 times higher than the Oxygen concentration in the zero gas.

Note: An N<sub>2</sub> gas of oxygen concentration of 0% can not be used for zero gas. Zirconia is a logarithmic measurement and 0% does not exist on a logarithmic scale. The "zero gas" must be a standard gas with a known and stable Oxygen concentration.

**Q9. What are two-point calibration and one-point calibration?**

A9. There are two calibrations for zirconia oxygen analyzers; two-point calibration using zero and span gases, and one-point calibration using only a span gas.

**1. Two-point Calibration:**

The following figure shows a two-point calibration using two gases: zero and span. Cell electromotive forces for a span gas with an oxygen concentration p1 and a zero gas with an oxygen concentration p2 are measured while determining the calibration curve passing between these two points. The oxygen concentration of the measurement gas is determined from this calibration curve.

In addition, the calibration curve corrected by calibration is compared with the theoretical calibration curve for determining the zero-point correction ratio represented by B/A × 100 (%) on the basis of A, B and C shown in the bellow figure and a span correction ratio of C/A × 100 (%). If the zero-point correction ratio exceeds the range of 100±30 % or the span correction ratio becomes larger than 0±18 %, calibration of the sensor becomes impossible.

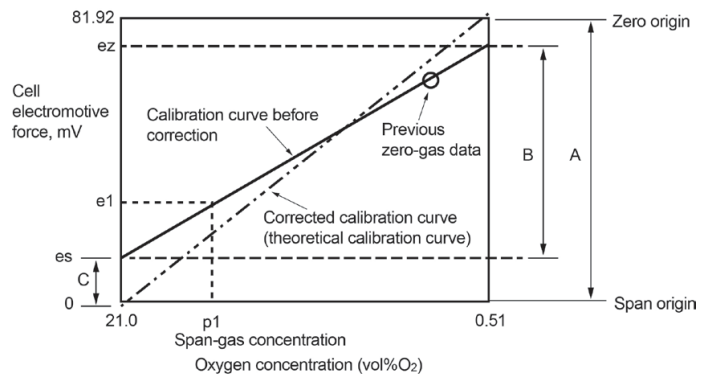

Zero-point correction factor = (B/A) × 100 (%) Correctable range: 100 ± 30%  
 Span correction factor = (C/A) × 100 (%) Correctable range: 0 ± 18%

Calculation of a Two-point Calibration Curve and Correction Factors using Zero and Span Gases

## 2. One-point Calibration:

The next figure shows a one-point calibration using only a span gas. In this case, only the cell electromotive force for a span gas with oxygen concentration  $p_1$  is measured. The cell electromotive force for the zero gas is carried over from a previous measurement to obtain the calibration curve.

The principle of calibration using only a span gas also applies to the one-point calibration method using a zero gas only.

The way of "Zero-point correction Factor" and "Span correction Factor" is the same as the case of Two-point Calibration.

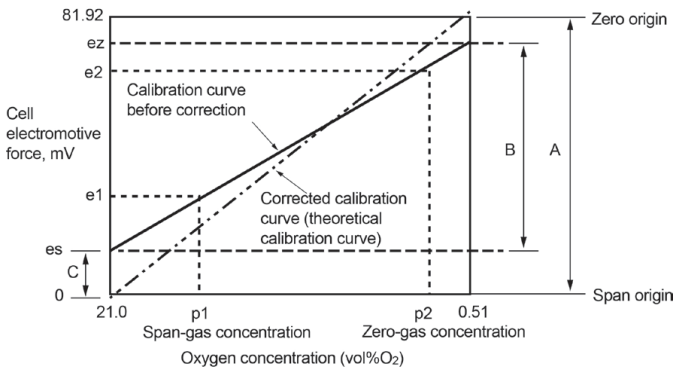

Zero-point correction factor =  $(B/A) \times 100$  (%) Correctable range:  $100 \pm 30\%$   
 Span correction factor =  $(C/A) \times 100$  (%) Correctable range:  $0 \pm 18\%$

Calculation of a One-point Calibration Curve and Correction Factors using a Span Gas

### Q10. Calibration operation modes and calibration time setting

A10. There are three calibration modes available :

- **Manual calibration** which allows zero and span calibrations or either one manually in turn;
- **Semi-automatic calibration** which lets calibration start with the touchpanel or a contact input, and undergoes a series of calibration operations following preset calibration periods and stabilization time;
- **Automatic calibration** which is carried out automatically following preset calibration periods.

Calibrations are limited by the following mode selection:

#### 1. When the calibration mode is in Manual:

First, set the output stabilization time. This indicates the time required from the end of calibration to entering a measurement again.

This time, after calibration, the measurement gas enters the sensor to set the time until the output returns to normal.

The output remains held after completing the calibration operation until the output stabilization time elapses. The calibration time set ranges from 00 minutes, 00 seconds to 60 minutes, 59 seconds.

#### 2. When the calibration mode is in Semi-automatic:

In addition to the above output stabilization time and calibration time, set the interval, set the output stabilization time and calibration time.

The calibration time is the time required from starting the flow of the calibration gas to reading out the measured value.

The set calibration time is effective in conducting both zero and span calibrations. The following figure shows the relationship between the calibration time and output stabilization time.

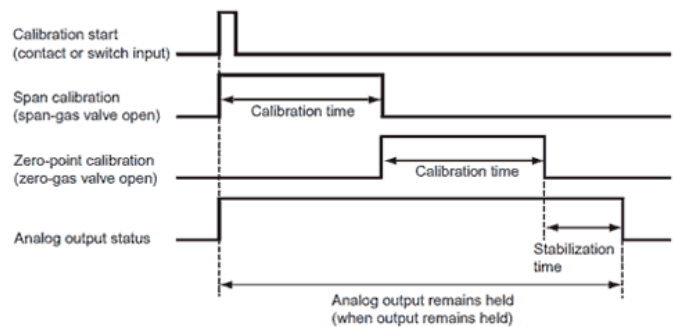

#### 3. When the calibration mode is in Automatic:

In addition to the above output stabilization time and calibration time, set the interval, start date, and start time.

Interval means the calibration intervals ranging from 000 days, 00 hours to 255 days, 23 hours. Set the first calibration day and the start-calibration time to the start date and start time respectively.

Q11. What is preventive maintenance functions of the zirconia oxygen analyzer?

A11. There The following information necessary for routine maintenance can be displayed. This information can be used to determine the calibration period and prepare for the zirconia cell in a timely manner.

#### 1. Span-gas and Zero-gas Correction Ratios

These are used to check for degradation of the sensor (cell). If the correction ratio is beyond the Correctable range, the sensor should no longer be used. These ratios can be found by calculating the data as shown below.

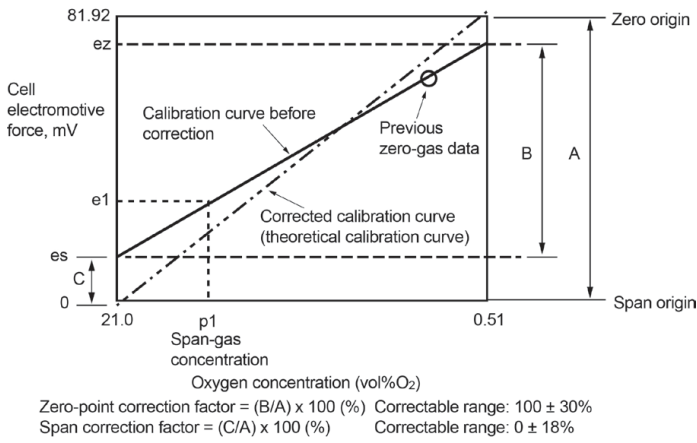

**Span-gas and Zero-gas Correction Ratios**

**2. Response Time**

The cell's response time is obtained in the procedure shown in below figure.

If only either a zero-point or span calibration has been carried out, the response time will not be measured just as it will not be measured in manual calibration.

The response time is obtained after the corrected calibration curve has been found.

The response time is calculated, starting at the point corresponding to 10% of the analog output up to the point at 90% of the analog output span. That is, this response time is a 10 to 90% response.

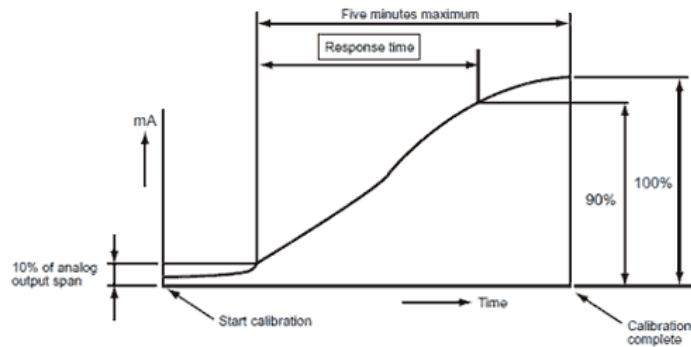

**Response Time**

**3. Robustness of a Cell**

The robustness of a cell is an index for predicting the remaining life of a sensor and is expressed as one of four time periods during which the cell may still be used: more than a year, more than six months, more than three months, less than one month.

The above four time periods are tentative and only used for preventive maintenance, not for warranty of the performance.

This cell's robustness can be found by a total evaluation of data involving the response time, the cell's internal resistance, and calibration factor. However, if a zero or span calibration was not made, the response time cannot be measured. In such a case, the cell's robustness is found except for the response time.

**4. Cell voltage**

The cell (sensor) voltage will be an index to determine the amount of degradation of the sensor. The cell voltage corresponds to the oxygen concentration currently being measured. If the indicated voltage approximates the ideal value (corresponding to the measured oxygen concentration), the sensor will be assumed to be normal.

The ideal value of the cell voltage (E), when the oxygen concentration measurement temperature is controlled at 750°C., may be expressed mathematically by:

$$E = -50.74 \log (P_x/P_A) \text{ [mV]}$$

where,  $P_x$ : Oxygen concentration in the measured gas  
 $P_A$ : Oxygen concentration in the reference gas, (21% O<sub>2</sub>)

**Oxygen Concentration Vs. Cell Voltage (cell temperature: 750°C )**

% O <sub>2</sub>	mV
0.1	117.83
0.2	102.56
0.3	93.62
0.4	87.28
0.5	82.36
0.6	78.35
0.7	74.95
0.8	72.01
0.9	69.41
1	67.09
2	51.82
3	42.88
4	36.54
5	31.62

% O <sub>2</sub>	mV
6	27.61
7	24.21
8	21.27
9	18.67
10	16.35
21	0
30	-7.86
40	-14.2
50	-19.2
60	-23.1
70	-26.5
80	-29.5
90	-32.1
100	-34.4



## 5. Cell's Internal Resistance

A new cell (sensor) indicates its internal resistance of 200  $\Omega$  maximum. As the cell degrades, so will the cell's internal resistance increase.

The degradation of the cell cannot be found only by changes in cell's internal resistance, however. Those changes in the cell's internal resistance will be a hint to knowing the sensor is degrading. The updated values obtained during the calibration are displayed.

*Q12. After replacement of sensor, what are the tasks that is necessary?*

A12. There After replacement of sensor, carry out surely Two-point Calibration using zero and span gases.

Note that calibration should usually be performed in the measurement state (in the operation state of the furnace when the analyzer is installed near the furnace).

## 8.4 Accessories

*Q1. Can we use Nitrogen as Zero Gas?*

A1. Since N<sub>2</sub> gas grade available may contain traces of Oxygen, the cell voltage becomes unstable & high. So we cannot use only Nitrogen as Zero gas.

*Q2. When to use probe filter?*

A2. It is used mostly for coal fired Boilers & applications where dust/ fly ash is present. Keep in mind the presence of filters will increase the response time

## 8.5 Models

*Q1. What if the sample temperature is higher than the recommended temperature?*

A1. Use the High temperature version configuration where an adapter is added to the normal configuration with SS/ SiC options for the probe, Up to 1400°C sample temperature can be measured with the high temperature option.

*Q2. What types of Zirconia Oxygen Analyzers exist, and how are they selected?*

A2. Yokogawa offers the following zirconia oxygen analyzers. Select an appropriate one according to your application and usage.

- **ZR22G/ZR402G** Direct In-Situ Zirconia Oxygen Analyzer (Separate type)
- **ZR202G** Direct In-Situ Zirconia Oxygen Analyzer (Integrated type)

- **ZR22S/ZR202S** Explosionproof Zirconia Oxygen Analyzer
- **AV550G** Zirconia Oxygen Averaging Converter
- **OX400** Low Concentration Zirconia Oxygen Analyzer

### 1. ZR202G Direct In-Situ Zirconia Oxygen Analyzer (Integrated type)

The integrated type zirconia oxygen analyzer combines probe and converter. The wiring cost and the installation fee can be decreased compared with the separate type by the integrated one. The converter can be operated in the field using an optical switch without opening the cover. On the other hand, there are some restrictions such as the sample gas temperature (700°C or less) and functions.

### 2. ZR22S/ZR202S Explosionproof Zirconia Oxygen Analyzer

Two types are available explosionproof direct in situ zirconia oxygen analyzer. The ZR22S/ZR402G is a separate type which consists of a ZR22S explosionproof probe and a ZR402G non-explosionproof converter. The ZR202S is an integrated type which combines a probe and a converter. Separate and integrated type Zirconia oxygen analyzers do not need a sampling device, and allow direct installation of the probe in the wall of a flue or furnace to measure the concentration of oxygen in the stack gas. The converter displays the cell temperature and cell emf in addition to the oxygen concentration. This analyzer is most suitable for monitoring combustion and controlling the low-oxygen combustion of various industrial furnaces in explosive atmosphere at petroleum refinery, petrochemical plant, and natural gas plant.

### 3. AV550G Zirconia Oxygen Averaging Converter

The AV550G Averaging Converter can accept inputs from up to 8 zirconia oxygen detectors ZR22G. With large boilers used in the utility industry, the oxygen concentration varies in different zones across the flue. In order to obtain the most reliable oxygen data, the most common method used is the arithmetical averaging of several measuring points using an external averaging unit. The model AV550G Averaging Converter not only averages the signals but fully controls all of the individual detectors thereby eliminating the need for costly, redundant hardware or DCS programming.

## 9. Lock Out Specifications

### 9.1 Oxygen Analyzer System Specification for a Single Channel Analyzer and Detector Requirements

#### Oxygen Analyzer/Converter

**Human Machine Interface:** Shall be performed via an LCD touchscreen display, with monochromatic display and 320 by 240 dot resolution.

**Trend Graph function:** The analyzer shall provide a trend graph function.

**Oxygen concentration value:** The analyzer system shall be able to measure 0.01 to 100% volume oxygen

**Output signal:** The analyzer system shall have two a user configurable 4 to 20 mA output signals

**Contact output signal:** The analyzer shall have four points, of which, one is "fail-safe" or normally open  
**Contact input signal:** The analyzer shall have two points, voltage free contacts. The input contact feature shall have the ability for remote range change from either a remote contact point or automatic control on a DCS. For eg., in combustion control applications, initially the customer will use the default (non-changeable) range from 0 to 25 %. Later when the process to be measured (flue gas) starts, the range required to be changed to 0 to 10% for eg., in thermal power plants.

**Automatic Calibration Output:** The calibration output shall have two output contact points dedicated for an auto-calibration unit

**Contact capacity:** Off-state leakage current shall be 3mA or less

**Digital Communication:** The analyzer system shall be HART® communications compatible

**Repeatability:** The analyzer shall have a repeatability factor of  $\pm 0.5\%$  maximum value of set range is 0 up to 25% O<sub>2</sub>.

**Linearity:** The analyzer shall have a linearity measurement of  $\pm 1\%$  maximum value of set range (Excluding calibration gas tolerances) is 0 up to 25% O<sub>2</sub>.

**Response time:** The analyzer system shall have a response time of 90% of span within 5 seconds

**Display:** The analyzer shall be able to simultaneous display three different measurement parameters. Items to be displayed shall consist of Oxygen

concentration, alarm and error notification, and 4 to 20 mA output, and menu icons.

**Diagnostics:** The analyzer system shall be able to diagnose the following items: Span correction, zero correction, calibration history, response time, Zr cell robustness, Zr cell resistance, heater on time ratio, mA loop check, contact I/O check, alarm and error indications, abnormal cell, abnormal cell temperature, defective digital circuits.

**Maximum Cable Distance:** The analyzer maximum distance between the detector and converter can be up to 300 m, when the conductor two-way resistance must be 10  $\Omega$  or less (when a 1.25 mm<sup>2</sup> cable or equivalent is used), or 500 m, when the conductor two-way resistance must be 10  $\Omega$  or less (when a 2 mm<sup>2</sup> cable or equivalent is used).

**Alarms:** The analyzer shall have a user configurable (programmable) alarm, to feature High, High-High, and Low, Low-Low, and oxygen concentration alarms.

- **The Analyzer shall meet or exceed the following Power and Safety requirements:**
  - The analyzer shall have a universal power supply
  - Power Supply Voltage: Ratings; 100 to 240 VAC, with an acceptable range of 85 to 264 VAC
  - Power Supply Frequency: 50 to 60 Hz, with an acceptable range of 45 to 66 Hz
  - Power Consumption: Max. 300 W, approximately 100W for normal conditions
  - Safety:
    1. EN 61010-1: 1993
    2. CSA C22.2, No. 61010-1 certified
    3. UL 3111-1 certified
  - EMC: EN 61326: 1998
- **Installation requirements:**
  - The analyzer shall have an ambient operating temperature range of: -20°C to 55°C (-4°F to 131°F)
  - The analyzer shall have installation location requirement: Indoor/Outdoor, panel or pipe mount
  - Ambient Humidity: The analyzer shall be able to withstand ambient humidity conditions of 0 to 95% Relative Humidity
- **Construction:**
  - The analyzer shall conform to NEMA 4X or Equivalent weather resistant and corrosion resistance standards.
  - The finish on the analyzer shall be a Polyurethane, corrosion resistant coating

#### Zirconia Oxygen Detector

**Measurement system:** The analyzer system shall utilize a molecularly bonded Zirconia/Platinum sensor

**Sample gas temperature:** The detector shall be capable of taking in situ oxygen gas measurements with process operating temperatures of 0 to 700°C (32°F to 1292°F), up to 1871°C (3400°F) with a high temperature adapter

**Sample gas pressure:** The detector shall be capable of taking in situ oxygen gas measurements with process pressures in the range of -0.725 psi to 36 psi.

**Probe construction:** The oxygen probe shall be constructed of the following materials:

- Wetted probe material (In situ): SUS 316, Zirconia/Platinum cell, Hastelloy B (Inconel 600, 601)
- Flange material: SUS 304
- The probe shall utilize a Type K thermocouple for cell temperature indication
- Terminal Box: Aluminum alloy, with a Polyurethane, corrosion resistant coating
- The detector shall be available in custom lengths up to 5.4 meters

**Calibration system requirements:**

- The system calibration shall not require a snubber or diffuser.
- Calibration gases flow rates: The Zero gas flow rate shall be 0.6 LPM or less, and the Reference gas flow rate shall be 0.8 LPM or less
- Reference air system: The detector shall be able to operate utilizing natural convection, instrument air or pressure compensated reference air
- Zero calibration gas: shall consist of 1% oxygen balanced in nitrogen

\*\*Based on the following guide lines, specifications and requirements, the model analyzer and detector chosen for this application shall be the Yokogawa ZR402G Single Channel Oxygen Analyzer, and the ZR22G Zirconia Oxygen Detector.\*\*

## 9.2 Oxygen Analyzer System Specification for an Integrated type Oxygen Analyzer and Detector Requirements

**Measurement system:** The measurement system shall utilize a molecularly bonded Zirconia/Platinum Oxygen cell with an integrated electronic analyzer.

**Human Machine Interface:** Shall be performed via a monochromatic 6 digit LCD display and three optical switches

**Oxygen concentration value:** The analyzer system shall be able to measure 0.01 to 100% volume oxygen

**Output signal:** The analyzer system shall have a user configurable 4 to 20 mA output signal.

**Contact output signal:** The analyzer shall have two points, of which, one is "fail-safe" or normally open.

**Automatic Calibration Output:** The calibration output shall have two output contact points dedicated for an auto-calibration unit. An optional integrated auto-calibration unit shall be made available.

**Digital Communication:** The analyzer system shall be HART® communications compatible

**Repeatability:** The analyzer shall have a repeatability factor of  $\pm 0.5\%$  maximum value of set the range is 0 up to 25% O<sub>2</sub>.

**Linearity:** The analyzer shall have a linearity measurement of  $\pm 1\%$  maximum value of set range (Excluding calibration gas tolerances) is 0 up to 25% O<sub>2</sub>.

**Response time:** The analyzer system shall have a response time of 90% of span within 5 seconds.

**Display:** Items to be displayed shall consist of Oxygen concentration percentage, and alarm/error notification.

**Diagnostics:** The analyzer system shall be able to diagnose the following items: Abnormal cell, abnormal cell temperature (low/high), abnormal calibration, A/D converter abnormalities, and abnormal digital circuit.

**Alarms:** The analyzer shall have a user configurable (programmable) alarm, to feature High, High-High, and Low, Low-Low, and oxygen concentration alarms.

- **Power Requirements:**
  - **Power Supply Voltage:** Ratings; 100 to 240 VAC, with an acceptable range of 85 to 264 VAC
  - **Power Supply Frequency:** 50 to 60 Hz, with an acceptable range of 45 to 66 Hz
  - **Power Consumption:** Max. 300 W, approximately 100W for normal conditions

- **Safety and Electrical conforming standards:**

- **Safety:**
  - Conforms to EN 61010-1: 1993
  - Conforms to CSA C22.2, No. 61010-1 certified
  - Conforms to UL 3111-1 certified
- **EMC:** Conforms to EN 61326: 1998

- **Installation Requirements:**

- **Sample gas temperature:** The analyzer/detector shall be able to withstand sample gas temperatures of 0 to 0 to 700°C (32°F to 1292°F), up to 1871°C (3400°F) with a high temperature adapter.
- **Ambient Temperature:** The analyzer shall have an ambient operating temperature range of: -20°C to 55°C (-4°F to 131°F)
- **Location:** The analyzer shall have installation location requirement: Indoor/Outdoor, panel or pipe mount Ambient Humidity: The analyzer shall be able to withstand ambient humidity conditions of 0 to 95% Relative Humidity

- **Sample gas pressure:** The detector shall be capable of taking in situ oxygen gas measurements with process pressures in the range of -0.725 psi to 36 psi.
- **Construction:**  
The analyzer/detector shall be constructed for use in indoor or outdoor installation, and conform to NEMA 4X or equivalent weather and corrosion resistance standards.

The oxygen probe shall be constructed of, or consist of, the following materials:

- Wetted probe material (In situ): SUS 316, Zirconia/Platinum cell, Hastelloy B (Inconel 600, 601)
- Flange material: SUS 304
- Type K thermocouple
- Terminal Box: Aluminum alloy, Non-explosion proof, NEMA 4X equivalent with a Polyurethane, corrosion resistant coating
- The heater and thermocouple shall be replaceable.
- The detector shall be available in custom lengths up to 3.0 meters
- **Calibration system requirements:**
  - The system calibration shall not require a snubber or diffuser.
  - Calibration gases flow rates: The Zero gas flow rate shall be 0.6 LPM or less, and the Reference gas flow rate shall be 0.8 LPM or less.
  - Reference air system: The detector shall be able to operate utilizing instrument air or pressure compensated reference air.
  - Zero calibration gas: shall consist of 1% oxygen balanced in nitrogen.

\*\*Based on the following guide lines, specifications and requirements, the model analyzer and detector chosen for this application shall be the Yokogawa ZR202G Integrated Oxygen Analyzer/ Zirconia Oxygen Detector.\*\*

### 9.3 Oxygen Analyzer System Specification for Multi-Channel Averaging Oxygen Analyzer and Detector Requirements

**Human Machine Interface:** Shall be performed via a 5.7 inch, color LCD touchscreen display.

**Quantity of Detectors:** The averaging unit shall be able to display 1 to 8 oxygen detectors, expandable from 1 to 8 probes

**Graph display:** The averaging unit shall be able to display trend analysis and cascade graphs for all eight probes.

**Data display:** The averaging unit shall be able to display the following data items: maximum/minimum/average oxygen concentration (volume % O<sub>2</sub>),

calibration record, internal temperature rise alarm record, cell e.m.f. (mV), thermocouple e.m.f. (mV), cold junction resistance (Ω), cell temperature (°C), cold junction temperature (°C), span correction factor (%), zero correction factor (%), cell response time (seconds), cell condition, cell internal resistance (Ω), next calibration estimate (year/month/day), heater on time rate (%), time (year/month/day, hour/minute), software revision.

**Status message:** The averaging unit shall indicate alarm and error codes for individual probes.

**Validation Function:** The averaging unit shall be able to permit control room activation of the midpoint gas concentration validation.

**Hot swap function:** The averaging unit shall allow the user to change individual channel cards without having to power the unit down.

**Calibration:** The averaging unit shall be able to perform manual, semi-automatic and automatic calibration of all eight probes.

**Diagnostics:** The averaging unit shall be able to diagnose the following items of each probe: span correction, zero correction, calibration history, response time, Zr cell robustness, Zr cell resistance, heater on time ratio, mA loop check, contact I/O check, alarm and error indications, abnormal cell, abnormal cell temperature, defective digital circuits.

**Communications:** The averaging unit shall be HART® or Foundation Fieldbus® compatible, to include the ability to upgrade to Foundation Fieldbus®

- **Signals:**

**Output signal:** The analyzer shall have (3) 4 to 20 mA outputs representing averaged O<sub>2</sub> values as well as (8) 4-20mA outputs representing individual probe readings.

**Contact Output Signal:** The averaging unit shall have five contact output signal points, of which, four are user selectable.

**Contact Input:** The averaging unit shall have two points, voltage free contacts. The input contact feature shall have the ability for remote range change from either a remote contact point or automatic control on a DCS. For eg., in combustion control applications, initially the customer will use the default (nonchangeable range from 0 to 25 %. Later when the process to be measured (flue gas) starts, the range required to be changed to 0 to 10% for eg., in thermal power plants.

**Contact capacity:** Off-state leakage current, 3mA or less

- **Power Requirements:** The averaging unit shall have the following power requirements
  - Power Supply Voltage: Ratings; 100/115 VAC, 230 VAC,
  - Power Supply Frequency: 50Hz ± 5% to 60Hz ± 5%,
  - Power Consumption: Max 1kw  
Max 1.8 for warm-up
- **The Averaging Unit shall meet or exceed the following Power and Safety requirements:**
  - Safety:  
Conforms to EN 61010-1: 2001  
Conforms to CSA C22.2, No. 61010-1 certified  
Conforms to UL 61010B-1 certified
- **EMC:**
  - EN 61326, 2002
  - AS/NZS CISPER 11

**Construction:** The finish on the averaging unit shall be a Polyurethane corrosion resistant coating. The averaging unit shall have an option available for a NEMA 4 enclosure.

## Zirconia Oxygen Detector

**Measurement system:** The analyzer system shall utilize a molecularly bonded Zirconia/Platinum sensor

**Sample gas temperature:** The detector shall be capable of taking in situ oxygen gas measurements with process operating temperatures of 0 to 700°C (32°F to 1292°F), up to 1871°C (3400°F) with a high temperature adapter

**Sample gas pressure:** The detector shall be capable of taking in situ oxygen gas measurements with process pressures in the range of -0.725 psi to 36 psi.

- **Probe construction:** The oxygen probe shall be constructed of the following materials:
  - Wetted probe material (In situ): SUS 316, Zirconia/Platinum cell, Hastelloy B (Inconel 600, 601)
  - Flange material: SUS 304
  - The probe shall utilize a Type K thermocouple for cell temperature indication
  - Terminal Box: Aluminum alloy, with a Polyurethane, corrosion resistant coating
  - The detector shall be available in custom lengths up to 5.4 meters
- **Calibration system requirements:**
  - The system calibration shall not require a snubber or diffuser.

- Calibration gases flow rates: The Zero gas flow rate shall be 0.6 LPM or less, and the Reference gas flow rate shall be 0.8 LPM or less
- Reference air system: The detector shall be able to operate utilizing natural convection, instrument air or pressure compensated reference air
- Zero calibration gas: shall consist of 1% oxygen balanced in nitrogen

\*\*Based on the following guide lines, specifications and requirements, the model analyzer and detector chosen for this application shall be the Yokogawa AV550GG Multi- Channel Oxygen Analyzer, and the ZR22G Zirconia Oxygen Detectors. \*\*



**Customer Application Data Sheet**



Customer: \_\_\_\_\_  
 Tag No: \_\_\_\_\_ Address: \_\_\_\_\_  
 Plant Name: \_\_\_\_\_  
 Contact: \_\_\_\_\_  
 Telephone: \_\_\_\_\_ End User Location: \_\_\_\_\_  
 Email: \_\_\_\_\_

**1. General:**

**Measurement:**  Oxygen  Humidity  
**Application:**  Boiler  Furnace  Emissions  Other: \_\_\_\_\_  
**Fuel:**  Gas  Oil  Coal  Other: \_\_\_\_\_  
**Operation:**  Record  Control  Alarm  Indication  
**Classification:**  TIIS  FM  CSA  ATEX  General Purpose  
**Zone:** \_\_\_\_\_

**2. Instrument Specifications & Process Conditions:**

Description of Process: \_\_\_\_\_

	Min	Norm	Max	Units
Sample Temperature:	_____	_____	_____	_____
Sample Pressure:	_____	_____	_____	_____
Velocity:	_____	_____	_____	_____
Oxygen Concentration:	_____	_____	_____	_____
Sample Gas Flow:	_____	_____	_____	_____
Dust Content:	_____	_____	_____	_____
SO <sub>2</sub> Content:	_____	_____	_____	_____
CO/HCl/NO Content:	_____	_____	_____	_____
Combustible Content:	_____	_____	_____	_____
Moisture:	<input type="checkbox"/> YES	<input type="checkbox"/> NO		
Corrosive Gas:	<input type="checkbox"/> No Gas	<input type="checkbox"/> Gas	_____ ; _____	QTY
			_____ ; _____	QTY

Specific Properties of Process: \_\_\_\_\_

**3. Installation Data:**

Detector Location:  Furnace  Stack  Other: \_\_\_\_\_  
 Vibration:  No Vibration  Vibration  
 Mounting:  Horizontal  Vertical  deg  
 Indoor  Outdoor  Covered  
 Detector Length:  0.4m  0.7m  1.0m  1.5m  2.0m  
 2.5m  3.0m  3.6m\*  4.2m\*  4.8m\*  
 5.2m\*  other length: \_\_\_\_\_  
 Flange:  DIN  ANSI Size: \_\_\_\_\_  
 Instrument Air Connection:  Yes  No \_\_\_\_\_ bar  
 Calibration Method:  Manual  Automatic  Semi-Automatic  
 Converter Location:  Indoor  Outdoor  Covered (under roof)  
 Power Supply Available: \_\_\_\_\_ AC \_\_\_\_\_ DC  
 Distance of Detector to Converter: \_\_\_\_\_ ft \_\_\_\_\_ m  
 Ambient Temperature around Probe: \_\_\_\_\_ deg  
 Ambient Temperature around Analyzer: \_\_\_\_\_ deg

\*Note: Available only in the NA Territory

**4. Notes: Recommendation: (For Office Use Only)**

Recommended System(s)		
ZR22G <input type="checkbox"/>	High Temp Tee <input type="checkbox"/>	Portable Cal <input type="checkbox"/>
ZR22S <input type="checkbox"/>	Probe Protector <input type="checkbox"/>	Dust Filter <input type="checkbox"/>
ZR402G <input type="checkbox"/>	Probe Support <input type="checkbox"/>	Fly Ash Filter <input type="checkbox"/>
AV550G <input type="checkbox"/>	Integral AutoCal <input type="checkbox"/>	
ZR202G <input type="checkbox"/>	Auto Cal Panel <input type="checkbox"/>	
ZR202S <input type="checkbox"/>	Manual Cal Panel <input type="checkbox"/>	



**Yokogawa Electric Corporation**

World Headquarters  
9-32, Nakacho 2-chome,  
Musashino-shi, Tokyo 180-8750  
Japan  
[yokogawa.com/an](http://yokogawa.com/an)

**Yokogawa Corporation of America**

12530 W. Airport Blvd.,  
Sugar Land, TX 77478  
USA  
[yokogawa.com/us](http://yokogawa.com/us)

**Yokogawa Europe B.V.**

Euroweg 2, 3825 HD  
Amersfoort, The Netherlands  
[yokogawa.com/eu](http://yokogawa.com/eu)

**Yokogawa Engineering Asia PTE. LTD**

5 Bedok South Road, Singapore 469270,  
Singapore  
[yokogawa.com/sg](http://yokogawa.com/sg)

The contents of this document are subject to change without prior notice. All rights reserved. Copyright © 2017 Yokogawa Corporation of America.  
[Ed:01] Printed in USA TI 11M00A20-01E