User's
Manual

EXA OR

4-wire ORP Metering System
Model OR400G
ORP Converter

IM 12C4C1-01E

vigilantplant.[®]

INTRODUCTION

The OR400G ORP Converter is used to configure the EXA OR series "4-wire ORP Metering System." The use of this converter in combination with ORP Sensor (OR8ERG, OR8EFG or HA485 etc.) allows continuous measurement of ORP (Oxidation Reduction Potential) in a wide range of process. To have the converter deliver its full capabilities, read this instruction manual.

1. Specification Check

Upon arrival of the purchased product, unpack it carefully and make sure the product is completely free from any damage that may have occurred during transport. It is shipped in strict conformance to the purchaser's specifications. By way of precaution, confirm that the OR400G ORP Converter is the exact model you ordered. Also check that all accessory components (see page 2-5) are included. When confirming the specifications, refer to the model and suffix codes indicated on the nameplate on the instrument, For a description of the model and suffix codes, refer to Subsection 2.2.2.

MODEL	OR400G	SUPPLY	88-132V AC
SUFFIX	-1-J-A	OUTPUT	4-20mA DC
STYLE		NO.	
YOKOGAWA ◆ Made in Japan			

Example of Nameplate

2. Before Starting Measurement

The OR400G ORP Converter, when put into operation under the condition in which it was delivered, operates with the parameters set upon shipment (default data). Check whether or not the default data meet your operating conditions. Reset the parameters to suit your operating requirements, if necessary.

To check the defaults, make use of the sheet "Worksheet for Operation Parameter Setting" in the back of this manual.

It is advisable that, if any of the operation parameter settings have been changed, the new data be noted in this record. When you have determined the use of the S1, S2 and S3 contacts, attach the accessory seals in a suitable place next to the indicator lamps on the operation panel (so the use of the contacts are clearly identified).

3. Information Covered in This Manual

This manual covers all of the information for handling the OR400G ORP Converter, including instructions on installation, setting of operation parameters, inspection and maintenance. Information necessary to better understand the product is also included. For details on the handling of an ORP sensor used in combination with the OR400G and the holder to install the sensor, refer to their respective, separate instruction manuals.

Note that the instruction manuals listed in the following table are for the associated equipment used with the EXA OR series "4-wire ORP Metering System."

Manuals for Associated Equipment Used with the EXA OR series "4-wire ORP Metering System"

Model	Title of Manual	Publication No.
OR400G	ORP Converter	IM 12C4C1-01E
OR8ERG	ORP Sensor (KCl refillable type)	IM 12C04K01-01E
OR8EFG	ORP Sensor (KCl filling type)	IM 12C04J01-01E
HA485	Solid Electrolyte (Xerolite) ORP Sensor	IM 12C4Q1-02E
DPA485	ORP Sensor (Fer Chemical Processes)	IM 12C4Q1-03E
DPAS485	ORP Sensor (For Small Fermentation Tanks)	IM 12C4Q1-05E
PH8HG	Guide Holder	IM 12B07M02-01E
PH8HF	Flow-through type Holder	IM 12B07N01-01E
PH8HS	Submersion type Holder	IM 12B7M1-01E
797M	Detachable Holder (for DPAS485)	IM 12B7Q2-03E
PH8USG	Ultrasonic Oscillator	IM 19C1B3-01E
PH8PU1	Cleaning Pump/Tank	IM 19C1E1-01E
OR8TBG	Relay Terminal Box	IM 12C04W01-01E

Sys T01E.eps



[Conventions Specific to This instruction Manual]

In principle, this manual uses the following conventions to indicate specifically the labels on the keys, the information shown on the display panel, and the labels on the instrument.

1. Operation key

Indicated with []. (Example: "  key" means "[YES] key")

2. Information shown in the display section

Indicated with  [Example: On status display " " means **HOLD**]

[Example: operation key indicator " " means **YES**]

[Example: message display → ***WASH**]

[Example: data display → **205**(lit), **205**(flashing)]

3. Labels on instrument

Indicated with <and> [Example: contact output indicator lamp → <●S3> (on status), <○S3> (off status)]

[Example: Measurement mode → <MEASURE> mode]

4. Indication of flashing in figures

Appears in a light shade of gray.

(Flashing)



(Lit)



◆ After-sales Warranty

- During the warranty period, for repair under warranty carry or send the product to the local sales representative or service office. Yokogawa will replace or repair any damaged parts and return the product to you.
- Before returning a product for repair under warranty, provide us with the model name and serial number and a description of the problem. Any diagrams or data explaining the problem would also be appreciated.
- If we replace the product with a new one, we won't provide you with a repair report.
- Yokogawa warrants the product for the period stated in the pre-purchase quotation. Yokogawa shall conduct defined warranty service based on its standard. When the customer site is located outside of the service area, a fee for dispatching the maintenance engineer will be charged to the customer.
- In the following cases, customer will be charged repair fee regardless of warranty period.
 - Failure of components which are out of scope of warranty stated in instruction manual.
 - Failure caused by usage of software, hardware or auxiliary equipment, which Yokogawa Electric did not supply.
 - Failure due to improper or insufficient maintenance by user.
 - Failure due to modification, misuse or outside-of-specifications operation which Yokogawa does not authorize.
 - Failure due to power supply (voltage, frequency) being outside specifications or abnormal.
 - Failure caused by any usage out of scope of recommended usage.
 - Any damage from fire, earthquake, storms and floods, lightning, disturbances, riots, warfare, radiation and other natural changes.
- Yokogawa does not warrant conformance with the specific application at the user site. Yokogawa will not bear direct/indirect responsibility for damage due to a specific application.
- Yokogawa Electric will not bear responsibility when the user configures the product into systems or resells the product.
- Maintenance service and supplying repair parts will be covered for five years after the production ends. For repair for this product, please contact the nearest sales office described in this instruction manual.

◆ For the safe use of this equipment

The topics and information that need your special attention in handling the product are given in the text of this manual along with cautionary notes, such as WARNING or CAUTION, depending on the importance of the information. For safety reasons or to avoid possible damage to your equipment, strictly adhere to every cautionary note that appears in this manual. For a notation, such as a warning also indicated on the product, there is an alert mark in the manual.

(1) About This Manual

- This manual should be passed on to the end user.
- The contents of this manual are subject to change without prior notice.
- The contents of this manual shall not be reproduced or copied, in part or in whole, without permission.
- This manual explains the functions contained in this product, but does not warrant that they are suitable for the particular purpose of the user.
- Every effort has been made to ensure accuracy in the preparation of this manual. However, when you realize mistaken expressions or omissions, please contact the nearest Yokogawa Electric representative or sales office.
- This manual does not cover the special specifications. This manual may be left unchanged on any change of specification, construction or parts when the change does not affect the functions or performance of the product.
- If the product is not used in a manner specified in this manual, the safety of this product may be impaired.

(2) Safety and Modification Precautions

- Follow the safety precautions in this manual when using the product to ensure protection and safety of the human body, the product and the system containing the product.

(3) The following safety symbols are used on the product as well as in this manual.



DANGER

This symbol indicates that an operator must follow the instructions laid out in this manual in order to avoid the risks, for the human body, of injury, electric shock, or fatalities. The manual describes what special care the operator must take to avoid such risks.



WARNING

This symbol indicates that the operator must refer to the instructions in this manual in order to prevent the instrument (hardware) or software from being damaged, or a system failure from occurring.



CAUTION

This symbol gives information essential for understanding the operations and functions.



Tip

This symbol gives information that complements the current topic.



SEE ALSO

This symbol identifies a source to be referred to.

4.1.4 Electrode Checkup and Calibration	4-4
4.1.5 Operation Check	4-5
4.2 Steady Operation	4-7
4.2.1 Corrective Actions Against Failure	4-7
4.2.2 Inspection and Maintenance	4-7
4.3 Shutdown and Restart	4-8
4.3.1 Measures for Shutdown	4-8
4.3.2 Measures for Restarting	4-8
5. Parameter Setting	5-1
5.1 Setting Operation Summary	5-1
5.1.1 Operation, Setting and Service Levels	5-1
5.1.2 Key Operations	5-2
5.1.3 Points to be Noted in Implementing Setting	5-3
5.2 Setting Items	5-3
5.2.1 Setting Items at Operation Level	5-3
5.2.2 Items Set at Setting Level	5-4
5.2.3 Items Set at Service Level	5-5
5.3 Setting Procedures	5-6
5.3.1 Parameter Setting at Operation Level	5-7
5.3.2 Parameter Setting at Setting Level	5-8
5.3.3 Parameter Setting at Service Level	5-13
6. Electrode Checkup/Calibration Procedure	6-1
6.1 General	6-1
6.1.1 Electrode Checkup	6-1
6.1.2 Manual Calibration	6-1
6.1.3 Checkup Solution	6-1
6.1.4 Errors Occurring in Calibration	6-1
6.2 Electrode Checkup/Manual Calibration (Emf Correction) Procedure	6-2
6.2.1 Preparation	6-2
6.2.2 Electrode Checkup Operation	6-3
6.2.3 Manual Calibration (Emf Correction)	6-3
6.3 Manual Calibration (Tune-in) Procedure	6-4
6.3.1 Preparation	6-4
6.3.2 Manual Calibration (Tune-in)	6-4
7. Inspection and Maintenance	7-1
7.1 Regarding Overall 4-wire ORP Metering System	7-1
7.1.1 Inspection and Maintenance to be Implemented Periodically	7-1
7.1.2 Inspection and Maintenance to be Implemented on Occasion	7-1
7.2 Inspection and Maintenance Procedure for OR400G ORP Converter	7-2
7.2.1 Wiping off Front Cover (Window)	7-2
7.2.2 Inspection of Degree of Dryness Within the Converter	7-2
7.2.3 Replacement of Fuse	7-2
8. Troubleshooting	8-1
8.1 Corrective Actions in Case of a Converter Malfunction	8-1
8.1.1 Case Where ORP Converter Fails to Function	8-1
8.1.2 Case Where Problems are Found with Operation Keys or Displays	8-1
8.2 Corrective Actions in Case of Failure (Error) Detection	8-2

8.3 Corrective Actions in the Case of a Measurement Failure 8-3

■ **Worksheet for Operation Parameter Setting i**

Customer Maintenance Parts List CMPL 12C04C01-01E

Revision Record i

1. Procedures for Key Operation

This chapter introduces the basic patterns of key operation for the OR400G ORP Converter. These key operations are introduced to demonstrate how to use the keys and how to check the performance of the instrument before installation. For key operations used to check or change preset parameter settings, see Chapter 5.

1.1 Display Panel Section and Keys on Operation

Figure 1.1 shows the operation panel of the OR400G ORP Converter. There are operation keys and a display section on the panel. The six keys that can be seen through the front cover can be operated from the outside.

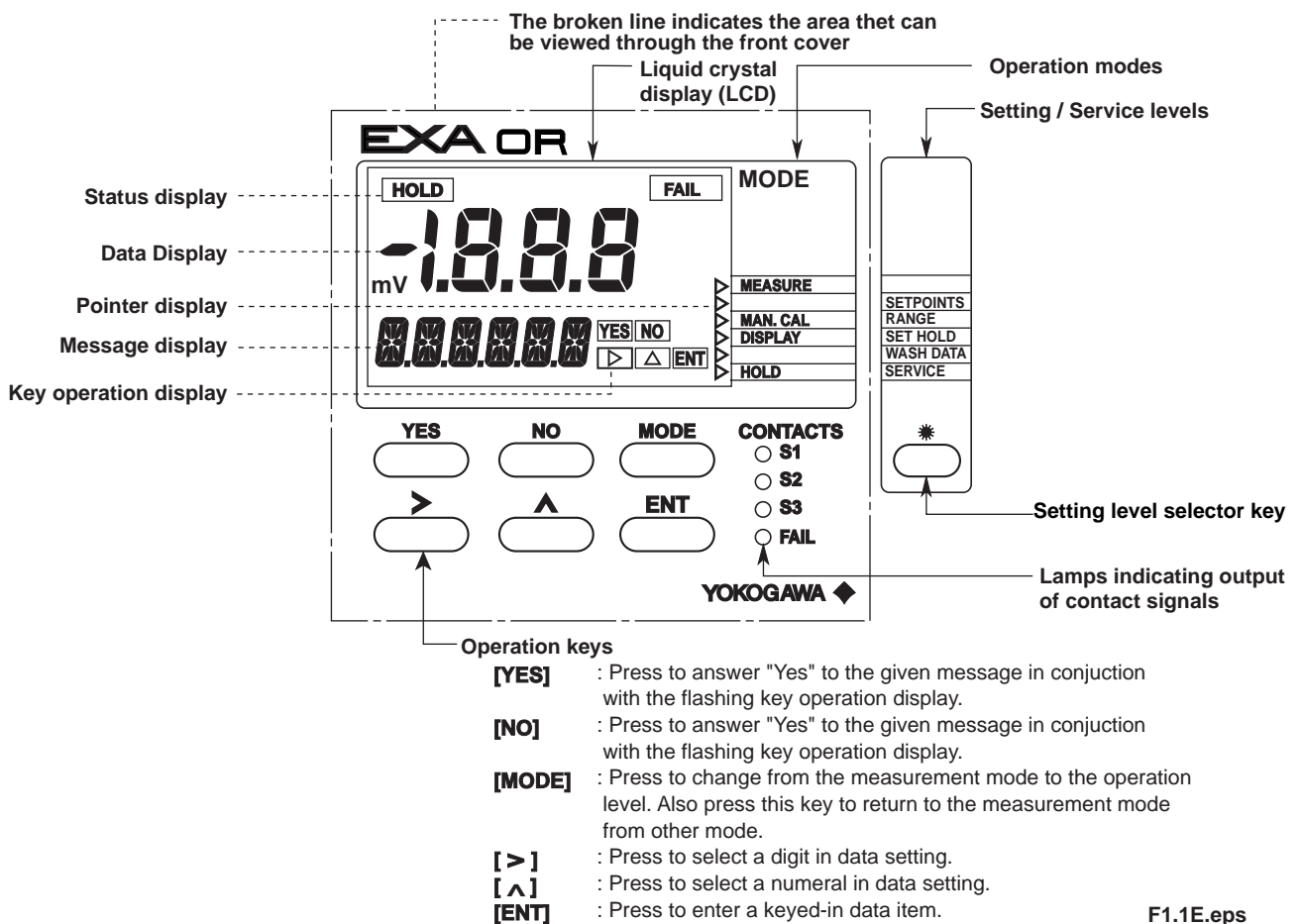

Figure 1.1 Operation Panel

1.2 Operating the ORP Converter

1.2.1 Connection of the ORP Sensor and Supply of Power

The OR400G ORP Converter operates on an AC power supply at the specified voltage. Before turning on the power, connect the ORP sensor. The ORP sensor can be connected with the membrane protective covering (for storage) left on.



The converter has no power switch. In order to avoid electrical shock or damage to the instrument, properly wire the sensor to the predetermined external wiring terminals of the converter before turning on the power.

Carry out wiring after removing both the front and terminal covers, as shown in Figure 1.2.

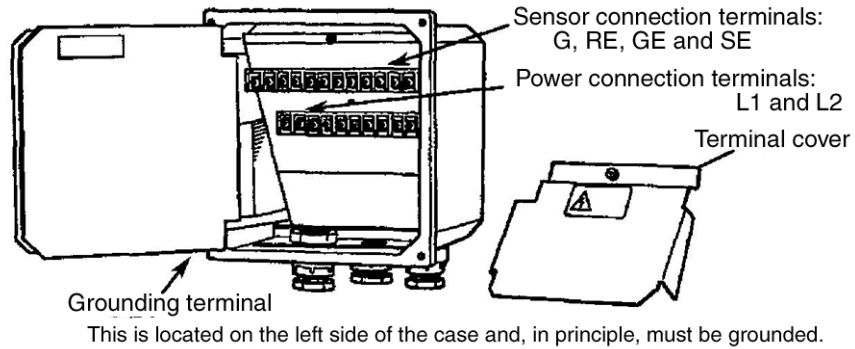

Figure 1.2 External Wiring Terminals

- When turned on, the converter starts in the measurement mode; the data display indicates an ORP value and the message display, the current of an output signal. (initial status)
- If the converter detects a failure, **FAIL** appears, the <FAIL> indicator lamp lights up, and the message display indicates an error code. Should a failure occur, go to Chapter 8.

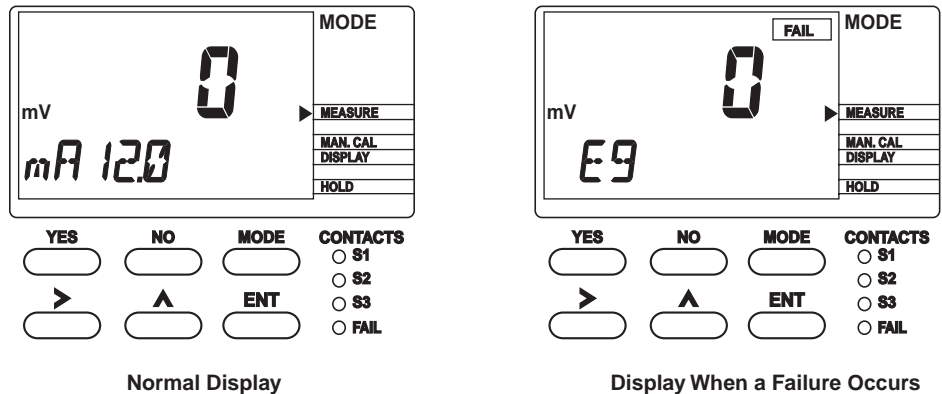

Figure 1.3 Example of Display in Measurement Mode

F1.3E.eps

1.3 Basic Key Operation

1.3.1 Mode Selection at Operation Level



SEE ALSO

For more information, see Section 5.3.

To check that key operation from the outside can be done normally, attach the front cover. In selecting a mode, note the following two points:

- Pressing the [MODE] key in modes other than the measurement mode returns to the measurement mode. However, pressing the key while the output signal hold is active goes to the <HOLD> mode.
- If no key is operated for ten minutes, the converter returns to the measurement mode. (Default setting).

1. Press the [MODE] key once. The display shown in Figure 1.4 (1) appears.

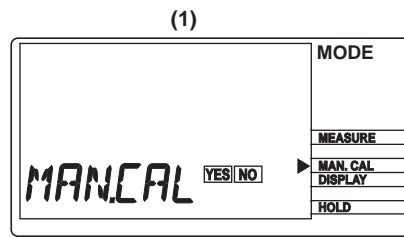

The pointer indicating <MAN.CAL> and **YES** and **NO** in the key operation display are flashing.

This indication means, "Do you want to do a manual calibration? Please answer by pressing the [YES] or [NO] key."

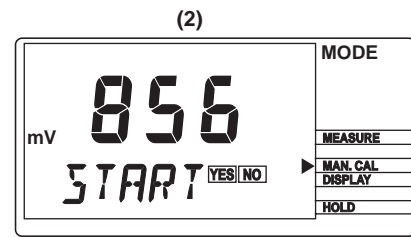

F1.4E.eps

This is the display when the [YES] key is pressed in answer to the indication in (1). As soon as the pointer stops flashing, the message display changes to **START**, indicating that the cover has entered the manual calibration mode.

Figure 1.4 Examples of Indication at Operation Level

2. Press the [NO] key for the display in Figure 1.4 (1). Each time you press the [NO] key, the display changes. After you have cycled through a round with this key operation, the converter returns to the display shown in Figure 1.4 (1).

1. Procedures for Key Operation

1.3.2 Operation to Switch to Setting Level

SEE ALSO

For more information, see Section 5.3.

To switch to the setting level, remove the front cover. In the measurement mode, press the [*] key (setting level selection).

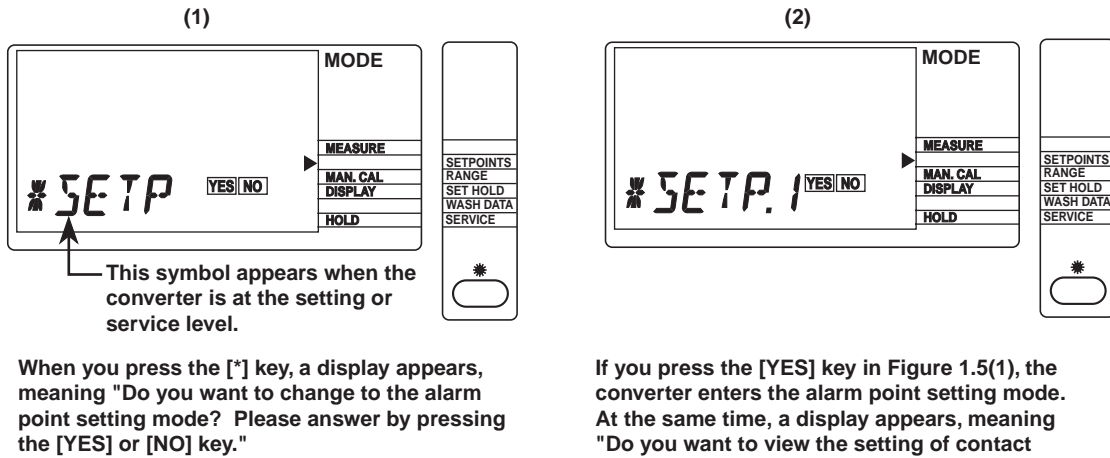

F1.5E.eps

Figure 1.5 Examples of Display at Setting Level

1.3.3 Operation to Enter Data (Numerical Values)



CAUTION

Entered data are not canceled even when the power is turned off. If you have made a temporary change in the data, enter the normal fixed data again.

If you press the [YES] key for the display in Figure 1.5 (2), the converter switches to the display shown in Figure 1.6 (1). The following procedure is for a case where you change the data value "-1000 (mV)" set in that display to "-500 (mV)."

- (1) Press the [\wedge] key once to change the flashing "-1" to a minus sign (-) only.
- (2) Press the [$>$] key once to have "0" in the hundreds place begin flashing.
- (3) Enter "5" with the [\wedge] key.
- (4) Press the [ENT] key. This enters the value "-500," and the converter then returns to the display shown in Figure 1.5 (1).

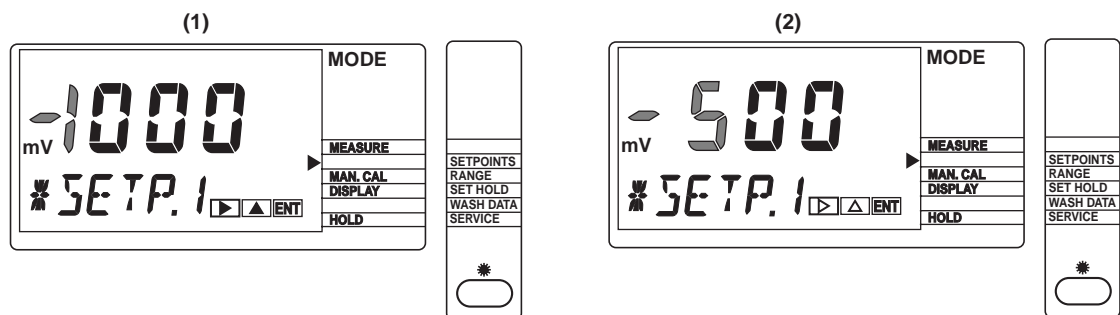

Pressing the [YES] key in Figure 1.5(2) changes the display to look like this.

Pressing the [ENT] key enters the displayed value.

F1.6E.eps

Figure 1.6 Examples of Display During Data Setting

2. Overview

This chapter gives an overview of the EXA OR series "4-wire ORP Metering System" and the specifications for the OR400G ORP Converter.

2.1 EXA OR series "4-wire ORP Metering System"

2.1.1 ORP Sensor

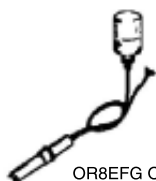

OR8EFG ORP sensor

The ORP sensor detects a potential generated by the oxidation-reduction reaction of a solution. ORP sensors include OR8EFG and OR8ERG sensors suited for a regular process, and HA485, DPA485 and DPAS485 sensors used for a special process.

2.1.2 OR400G ORP Converter

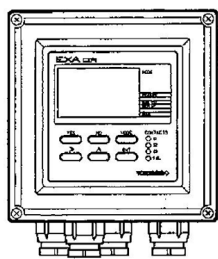

The OR400G ORP Converter A-to-D converts the oxidation-reduction potential received from an ORP sensor to indicate it in digital form. It outputs the potential as an analog signal of 4 to 20 mA DC. The converter is provided with a variety of operation parameter setting functions necessary to measure and control an oxidation-reduction potential as well as selfdiagnostic functions.

2.1.3 Holders

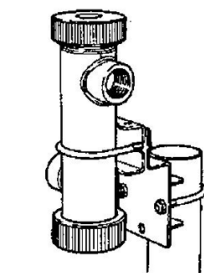

Flow-through holder

Submersion type holder
with cleaner

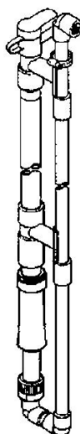

Equipment configuring the ORP Metering System includes holders to support the ORP sensor and a relay terminal box (with a dedicated extension cable) used if the sensor is located away from the converter. There are three types of holders: a guide holder, flow-through type holder, and submersion type holder. These are selected depending on the measurement conditions. The flow-through type and submersion type holders are available in versions having cleaners (jet, brush or ultrasonic) that remove dirt from the sensor's membrane.

2.2 Specifications for OR400G ORP Converter

The OR400G ORP Converter delivers an analog signal relative to an oxidation-reduction potential and many different contact signals such as upper/lower-limit alarms. Provided with many operation parameter setting functions, the converter lends itself to a wide variety of applications. It also has several self-diagnostic functions which simplify maintenance work.

2.2.1 Standard Specifications

Measurement:

Oxidation-reduction potential (ORP) of a solution

Measuring range:

-1500 to +1500 mV

Display:

digital (LCD), range -1500 to +1500 mV

Converter output:

4 to 20 mA DC, isolated (floating), maximum load resistance 600V.

Converter range:

output may be set to correspond to an arbitrary input span of at least 100 mV. (Shipping-time default is for output to correspond to -1500 to +1500 mV measuring range).

Contact output:

- Contact output function that can be set

Contact	Function	
S1	Setting (freely selectable)	Operation (freely selectable)
	OFF, Low limit, High limit, HOLD	ON/OFF
S2	OFF, Low limit, High limit, HOLD	Ditto
S3	OFF, Low limit, High limit, HOLD, Cleaning timer, Hi-Hi limit, Lo-Lo limit	Ditto
FAIL	Failure	ON/OFF

T02C.EPS

- Contact ON/OFF

(a) S1, S2, S3

		Power	
		ON	OFF
Action	ON	Closed	Open
	OFF	Open	Open

(b) FAIL

		Power	
		ON	OFF
Action	ON	Closed	Closed
	OFF	Open	Closed

T02D.EPS

When closed, each indicator lamp is lit corresponding to each contact status.

- Contact type : Relay contact output *dry contact
- Contact rating:
 - 250 V AC, 2 A, Max. 100 VA
 - 220 V AC, 2 A, Max. 50 W

Contact input:

Supports manual starting of auto-wash functions.

Power supply voltage:

88 to 132V AC or 176 to 264V AC at 50/60Hz.

Power consumption:

approx. 8.5VA

Operating temperature:

-10 to 55 °C

Operating humidity:

10 to 90 % RH

Storage temperature:

-30 to 70 °C

Construction:

Watertight complying with JIS C0920, equivalent to NEMA 4 water proof construction

Materials:

Case: Aluminum alloy casting

Cover and Window: Polycarbonate

Finish:

Baked polyurethane resin finish

Color:

Cover: Deep sea moss green (Munsell 0.6GY3.1/2.0 equivalent.)

Case: Frosty white (Munsell 2.5Y8.4/1.2 equivalent.)

Mounting:

50A dia. vertical or horizontal pipe, wall, rack or panel.

Condition of Installation

Installation is possible inside or outside Concerning its condition, see chap 3.1.

Electrical connections:

ORP sensor: 13.5mm dia. hole (plastic gland, watertight to JIS A8 equivalent.) Power, contacts, and output: 21mm dia., use cable of 9 to 12 mm dia. (plastic gland, watertight to JIS A15 equivalent.)

Weight:

Body: Approx. 2.5 kg

Mounting bracket: Approx. 0.5 kg

Dimensions:

144 x 144 x 135 mm

Standard Performance

Repeatability:

0.5% of input span (not including sensor)

Linearity:

0.5% of input span (not including sensor)

Operating Functions

Display:

3-1/2 digital display (data display)

Six digit alphanumerics (message or data display)

Display items:

ORP value (mV)

mA output

Zero-shift value

Interactive prompts

Key entry request (for hold value)

Error display (if error occurs)

Fail display (if failure occurs)

Operation-mode actions:

Message area display content selection

Set / release output hold setting

Manual calibration (one-point)

Maintenance-mode actions:

Setting of alarms S1, S2 and S3

Setting of output ranges

Setting of hold parameters

Enable/disable hold

Hold last value / Hold preset value setting

Setting of preset value

Setting of wash parameters

Selection of auto/manual wash

Manual wash start/stop

Auto wash enable/disable

Wash cycle interval: settable 0.1 to 36 hours

Settling time: settable 0.1 to 10 min.

Wash cycle duration: settable 0.1 to 10 min.

Service-mode actions:

Zero point check

Settling (to 50%) time check On / Off

Settling (to 50%) time setting (0.1 to 10 min.)

Burnout (upscale/downscale/Off)

Mode auto revert On / Off

Converter mA output On / Off

Error reset

Items detected by self-diagnostics:

ORP measurement value abnormal

Zero point shift abnormal

Settling time abnormal

EEPROM abnormal

2.2.2 Model and Codes

Model	Suffix Code	Option Code	Specifications
OR400G	4-wire ORP Converter
Power supply voltage	-1	100/110 V AC, 50/60 Hz
	-2	200/220 V AC, 50/60 Hz
Language for warning, etc.	-J	Japanese
	-E	English
_____	-A	Always -A
Option	Mounting hardware	/U	Pipe mounting bracket
		/PM	Panel mounting bracket
	Hood	/H3	Awning hood (carbon steel)
		/H4	Awning hood (stainlss steel)
		/X1	Epoxy-baked finish
	Tag plate	/SCT	with stainless tag plate
	Conduit Adapter	/AFTB	G1/2
		/ANSI	1/2NPT

T14.EPS

Accessories

Item	Part Number	Remarks
Label for contact signals	K9313PC	For display on the operation panel
Spare fuse	K9313PS	0.1 A (for either a 100V or 200V power line)
Pipe/wall mounting bracket	K9171SS	Attached when option code "/U" is specified
Panel mounting bracket	K9171ST	Attached when option code "/PM" is specified
Shading hood	K9664CA	Attached when option code "/H3" is specified
Shading hood	K9664CC	Attached when option code "/H4" is specified
Tag plate	Y9412NP	Attached when option code "/SCT" is specified
Adapter for conduit connection	K9313PN	Attached when option code "/AFTG" is specified

T2.5E.eps

2. Overview

2.2.3 External Dimensions

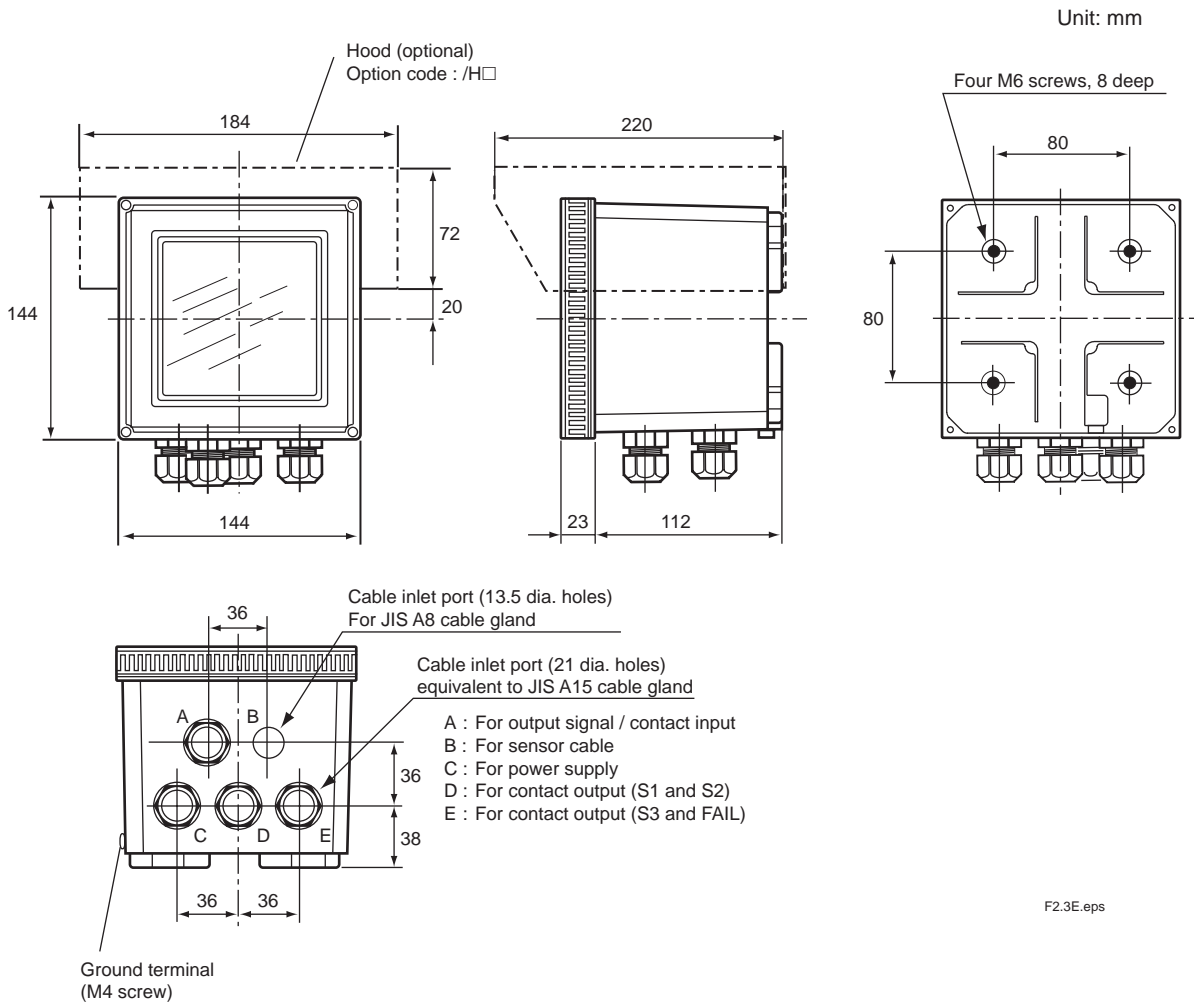

F2.3E.eps

Adapter for conduit work (option code:/AFTG, /ANSI)

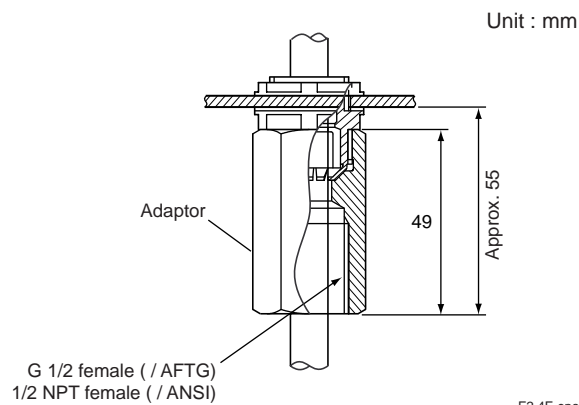

F2.4E.eps

Pipe Mounting Bracket/Wall Mounting Bracket (option code:/U)

- Example of bracket used for pipe mounting

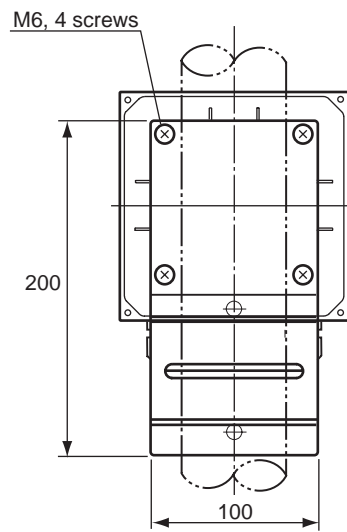
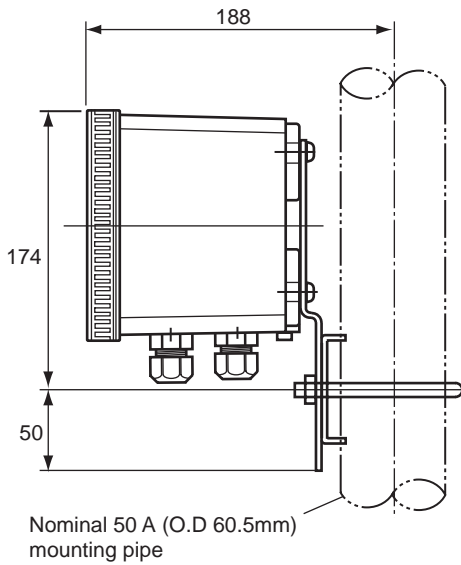

Unit : mm

- Example of bracket used for wall mounting

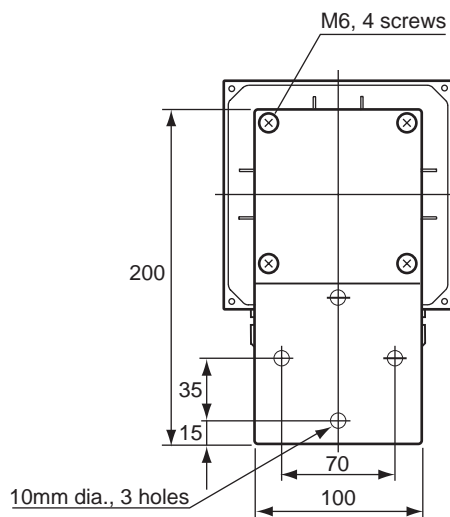
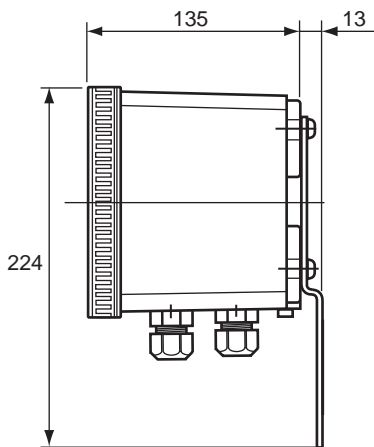

F2.5E.eps

Mounting Bracket (option code:/PM)

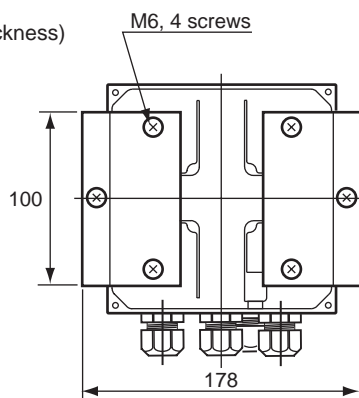
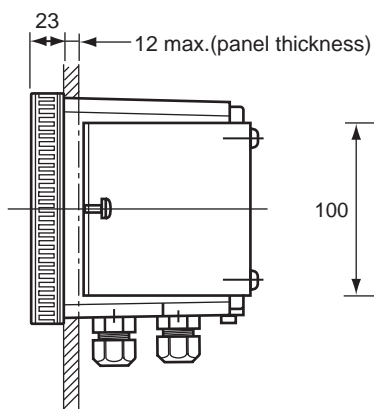

Unit : mm

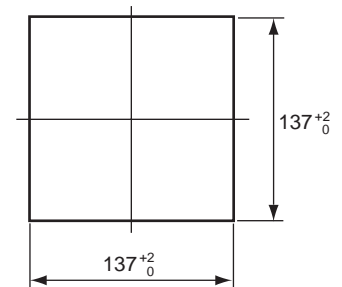

Panel cutout dimensions

F2.6E.eps

3. Installation and Wiring

The OR400G ORP Converter must be installed in a location where the operator can view the display normally and operate keys properly. This chapter explains how to select such a location and install and wire the converter.

3.1 Installation

3.1.1 Selection of Location

The OR400G ORP Converter can be installed both inside and outside.

Install the OR400G where the following conditions are met.

- **Near the ORP sensor**

Consider the cable length of the sensor the converter is to be combined with (including a dedicated extension cable). Even if relay terminal boxes are used, it is recommended that the total length of the sensor cable and the extension cable be within 25 m.

- **No presence of corrosive gases**

Corrosive gases are not desirable because they may damage the electrical components in the converter.

- **Little mechanical vibration**

Vibration may loosen the connections of the external wiring.

- **Normal temperatures with only small fluctuations**

It is necessary for the temperature not to exceed the range of -10 to 55 °C.

- **Humidity maintained between 10 to 90% RH**

Avoid choosing a location likely to be exposed to abnormally high or low humidity over a prolonged period. It is recommended that the converter be used at a humidity between 25 to 85 % RH.

- **No exposure to direct sunlight**

Direct sunlight may raise the temperature in the converter to abnormal levels. If direct sunlight cannot be avoided, use a hood for shading (optional).

3. Installation and Wiring

3.1.2 Preparation for Installation

3.1.2.1 Assembly of Separate Attachments

Parts specified with the option codes (hood, mounting bracket, adapter for conduit connection, etc.) are delivered as separate attachments. To avoid losing these parts, it is recommended that you attach them to the converter before installation. (For details on assembly, see Subsections 2.2.3 and 3.1.3.)

3.1.2.2 Installation Provisions

Make provisions to install the OR400G ORP Converter in a position for easy operation.

(1) Pipe mounting

The OR400G converter is fixed to a stanchion (pipe) with a U-bolt. Install a rigid pipe with an OD of 60.5 mm in an upright position (a horizontal position is also acceptable).

(2) Wall mounting

Fix the OR400G converter with three M8 bolts (not supplied). Drill the mounting surface of the wall, as shown in Figure 3.1.

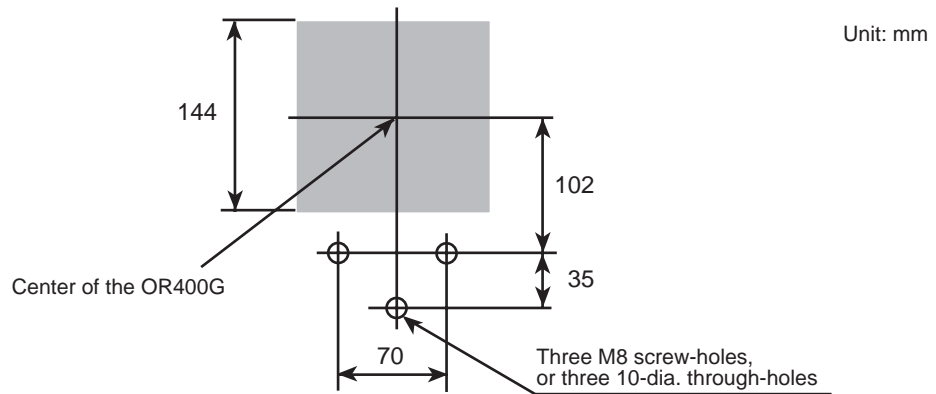

F3.1E.eps

Figure 3.1 Drilling for Wall Mounting

(3) Panel mounting

Provide a cutout on the panel, as shown in Figure 3.2.

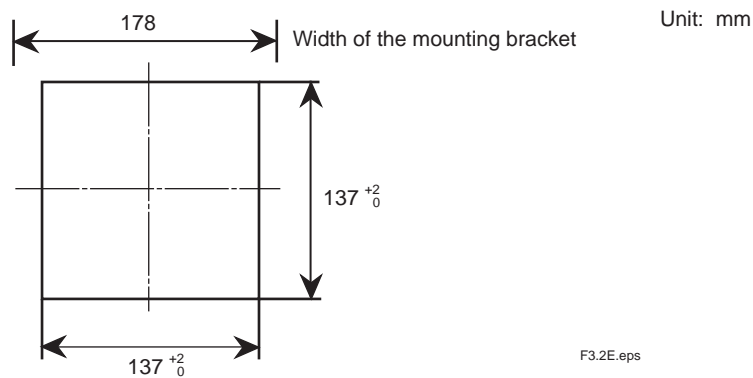

F3.2E.eps

Figure 3.2 Cutout for Panel Mounting

3.1.3 Converter Mounting

(1) Pipe mounting

Figure 3.3 shows the pipe mounting bracket and the mounting procedure.

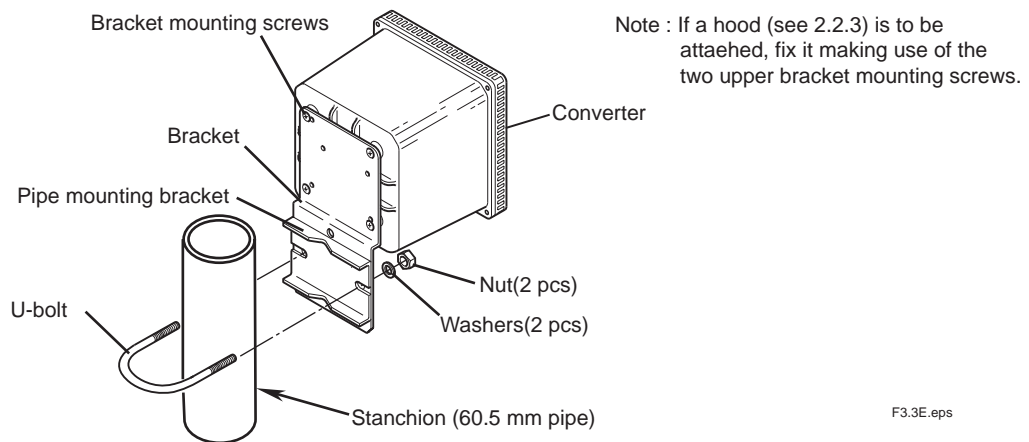

F3.3E.eps

Figure 3.3 Pipe Mounting Procedure

(2) Wall mounting

Figure 3.4 illustrates the wall mounting procedure.

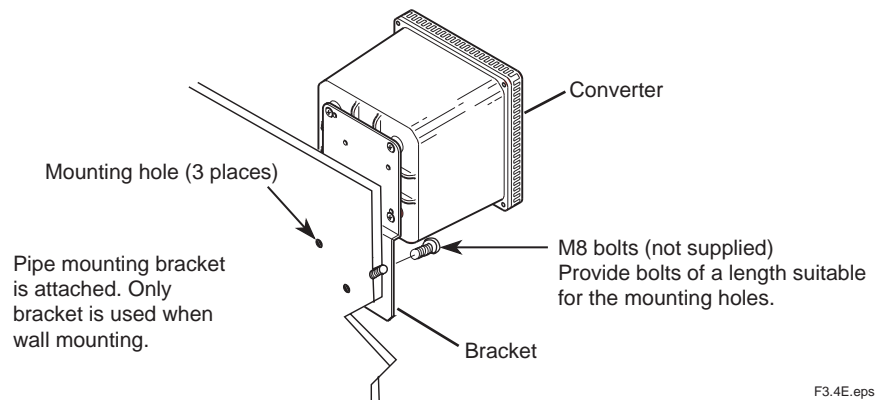

F3.4E.eps

Figure 3.4 Wall Mounting Procedure

(3) Panel mounting

Figure 3.5 illustrates the panel mounting procedure.

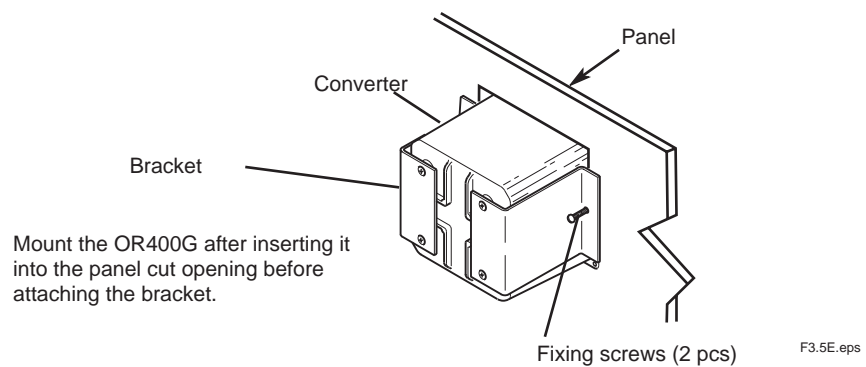

F3.5E.eps

Figure 3.5 Panel Mounting Procedure

3.2 Wiring

3.2.1 Types of Wiring for Converter

Provide the following types of wiring on the OR400G ORP Converter. However, do not wire for unused functions.

- (1) Sensor cable (or extension cable) connection (see Subsection 3.2.3)
- (2) Wiring for output signal and for remote cleaning start command (contact input) (see Subsection 3.2.4)
- (3) Wiring for high and low alarms (S1 and S2 contact outputs) (see Subsection 3.2.5)
- (4) Wiring for cleaning (or alarm) (S3 contact output) failure (FAIL contact output) (see Subsection 3.2.6)
- (5) Wiring for power supply (see Subsection 3.2.7)
- (6) Ground wiring (see Subsection 3.2.8)

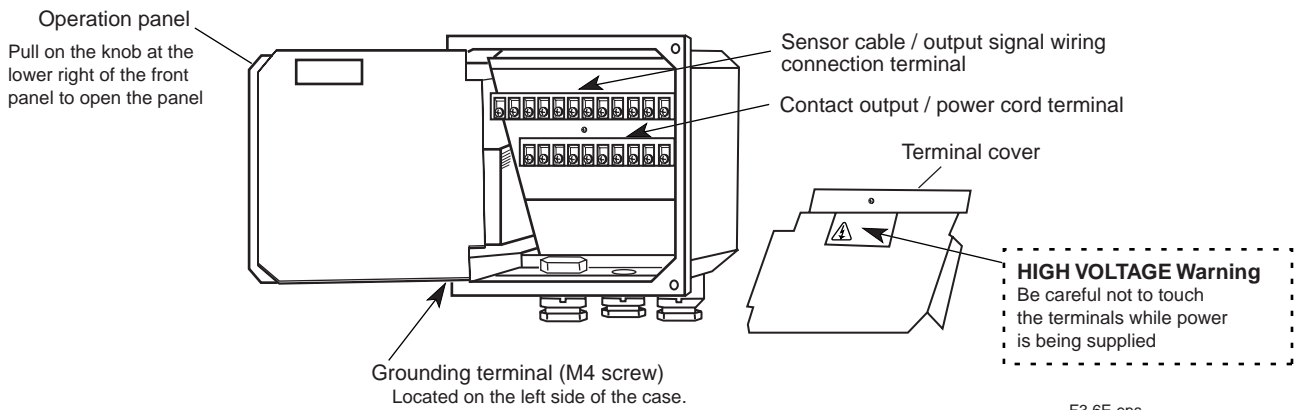

Figure 3.6 Position of terminal blocks for external wiring cable connection

Wiring

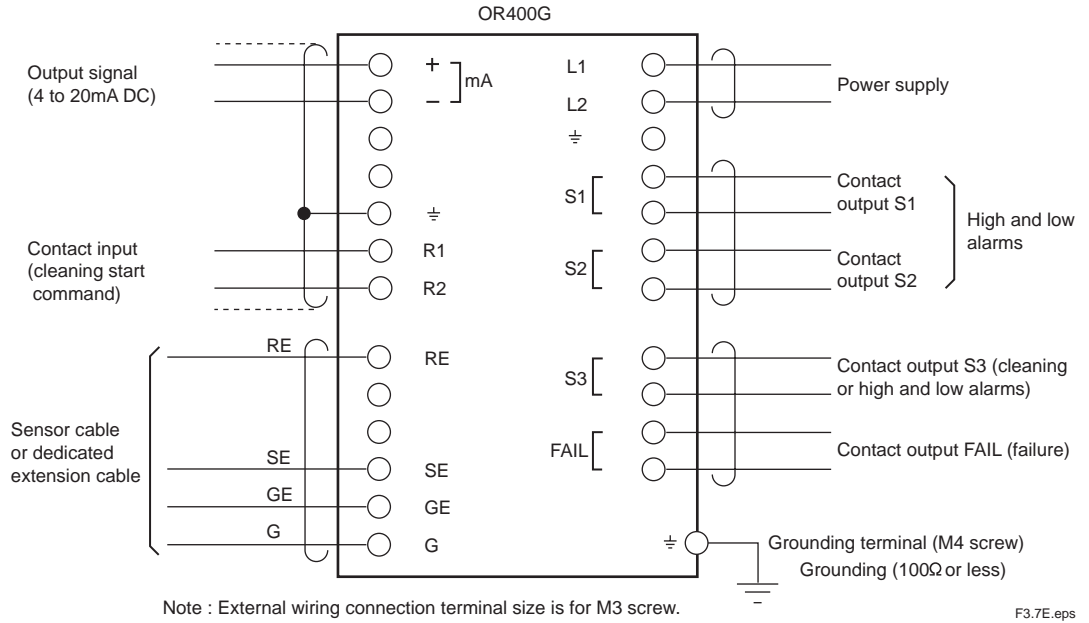

Figure 3.7 External Wiring Cable Connection Terminals and Hookup

3.2.2 Cable Inlet Port

There are four cable inlets on the OR400G ORP Converter in addition to the one for a sensor cable. These inlets have cable glands for a cable with an OD of 9 to 12 mm. Introduce cables through their respective inlets shown in Figure 3.8. If there is any cable inlet not used, seal the opening so that no dust gets in.

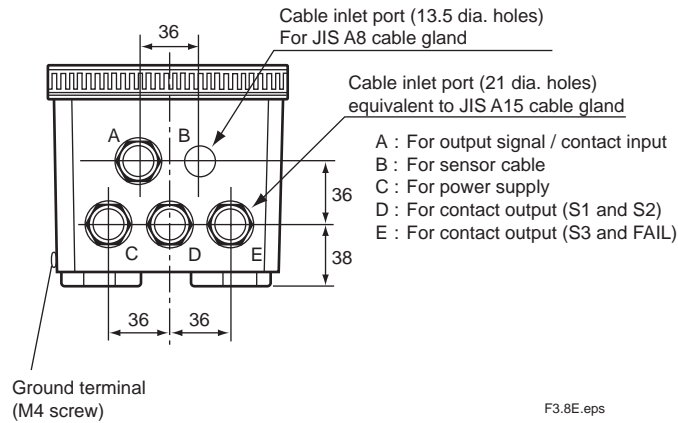

Figure 3.8 Use of Each Cable Inlet

When protecting a cable with a conduit, use an adapter (4 sets are supplied when the option code "/AFTG" is specified). Remove the glands from the A, C, D, and E cable inlets and attach the supplied adapters in place of the above glands, as shown in Figure 3.9. No conduit installation is required for sensor cable inlet B. Use the gland that is already assembled to the sensor cable.

 **CAUTION**

Be sure to use an OR8TBG Relay Terminal Box if it is necessary to protect all the wiring cables to the converter with conduits. The cable between the relay terminal box and the converter (dedicated extension cable) can be protected with a conduit. An adapter for that purpose can be supplied attached to the relay terminal box (specify accordingly).

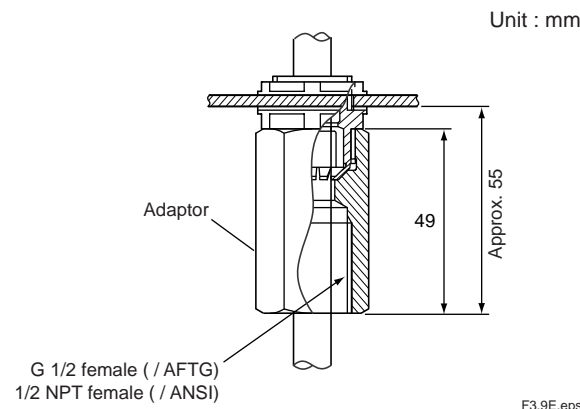

Figure 3.9 Conduit Connecting Adapter

3.2.3 Sensor Cable (or Dedicated Extension Cable) Connection

Normally, the sensor cable is connected directly to the converter. If an OR8TBG Relay Terminal Box is used, first connect the sensor cable to the box. Then, connect the box with the converter using the dedicated extension cable (supplied with the OR8TBG Relay Terminal Box). The sensor cable and the dedicated extension cable already have a finished end treatment.



The end treatment of a dedicated extension cable may differ between the connection with the relay terminal box and the connection with the converter. When using a dedicated extension cable, examine both ends before wiring the cable.

3.2.3.1 Connection Procedure

- (1) Connect each conductor of the sensor cable to the predetermined terminals of RE, SE, GE and G.



Some types of sensors use a cable lacking the G leadwire. These sensors have two SE leadwires. Connect both of them to terminal SE. When introducing the sensor cable into the converter, remove the nut from the sensor cable gland.

- (2) Fix the cable gland.
Insert the cable gland into the inlet and tighten the nut.

3.2.4 Wiring for Output Signal and Remote Cleaning Start Command

This is wiring for transmitting the converter's output signal to a receiving instrument, such as a recorder, and for sending a contact input signal to the converter to start cleaning. The output signal is a unified 4 to 20 mA DC signal corresponding to any preset range. The wiring for the contact input signal is necessary only when you use a remote cleaning start command in an application where the holder with a cleaner is used. The on/off contact input can be identified with input resistances (on: 10 Ω or less for more than 0.25 second; off: 100 k Ω or more). Use a dry contact.

3.2.4.1 Cable to Be Used

Use a shielded cable with a finished OD of 9 to 12 mm. Select either a 2 or 4 conductor cable depending on the number of signals.

3.2.4.2 Connection Procedure

(1) End-treat the cable.

Strip off about 40 mm of the cable insulation covering from the cable end. Cut the exposed shield at its root near the remaining covering and solder a grounding leadwire (about the same length as the cable conductors) to the shield. Protect the soldered point by wrapping it with insulation tape, for example. Next, attach crimping terminal lugs conforming to an M3 screw to the tips of the leadwire and each cable conductor.

(2) Connect each cable conductor to the specified terminals.

Plus (+) and minus (-) terminals	:conductors for 4 to 20 mA DC output signal
Grounding (\perp) terminal	:conductor grounding
R1 and R2 terminals	:conductors for contact input signal



CAUTION

Ground the cable shield only at the OR400G ORP Converter.

When introducing the cable into the converter, remove the parts assembled to the cable gland located at cable inlet A and pass the cable through these parts in the proper sequence in advance.

(3) Fix the cable.

Adjust the length of the portion of the cable housed within the converter and fix the cable by reassembling the parts through which the cable passes to the cable gland.

3.2.5 Wiring for High/Low Alarm Contact Output

This is the wiring provided to output high and low alarms as contact signals S1 and S2. This wiring can also be used to know that the output signal hold is "on" at the operation level. The ratings of these relay contacts (normally on) for contact signal outputs are summarized in Table 3.1.



Contact outputs S1 and S2 must be "open" when deenergized.

Table 3.1 Ratings of Relay Contacts for Contact Outputs

	DC	AC
Maximum allowable voltage	220V	250V
Maximum allowable current	2A	2A
Maximum allowable power	50W	100VA

T3.1E.eps

3.2.5.1 Cable to Be Used

Use a cable with a finished OD of 9 to 12 mm. Select either a 2 or 4 conductor cable depending on the number of signals.

3.2.5.2 Connecting Procedure

(1) End-treat the cable.

Strip off about 40 mm of the insulation from the cable end and attach crimping terminal lugs conforming to an M3 screw to the tip of each conductor.

(2) Connect each cable conductor to the specified terminals.

Terminals S1 (two): conductors for contact output S1

Terminals S2 (two): conductors for contact output S2

When introducing the cable into the converter, first remove the parts attached to the cable gland located at cable inlet D and pass the cable through these parts in the proper sequence in advance.

(3) Fix the cable.

Adjust the length of the portion of the cable housed within the converter and fix the cable by reassembling the parts through which the cable passes to the cable gland.

3.2.6 Wiring for Cleaning (or Alarm) / FAIL Contact Output

In an application where a holder with a cleaner is used, the cleaning signal is delivered from the S3 contact output. In other applications, the S3 contact output can be used for the high (or low) alarm. From the FAIL contact output, a failure signal is output if the converter detects a failure. This wiring is done if these contact signals are used.

The ratings of the relay contacts (normally open) for contact signal outputs are the same as those of contact S1 or S2 shown in Table 3.1. When connecting equipment to these contact outputs, make sure that the equipment satisfies the ratings.



Contact S3 is "open" at power off, while the FAIL contact output is "closed."

3.2.6.1 Cable to Be Used

Use a cable with a finished OD of 9 to 12 mm. Select a 2 or 4 conductor cable depending on the number of signals applied.

3.2.6.2 Connecting Procedure

(1) End-treat the cable.

Strip off about 40 mm of the insulation from the cable end and attach crimping terminal lugs conforming to an M3 screw to the tip of each conductor.

(2) Connect each cable conductor to the specified terminals.

S3 terminals (two) : conductors for contact output S3

FAIL terminals (two) : conductors for contact output FAIL

When introducing the cable into the converter, remove the parts attached to the cable gland located at cable inlet E and pass the cable through these parts in the proper sequence in advance.

(3) Fix the cable.

Adjust the length of the portion of the cable housed within the converter and fix the cable by reassembling the parts through which the cable passes to the cable gland.

3.2.7 Wiring for Power Supply

Supply AC power of the specified voltage (88 to 132 V or 176 to 264 V) and frequency (50 / 60 Hz) to the OR400G ORP Converter.



The OR400G ORP Converter has no power switch. Be sure to provide a double-pole switch in the power line. Use a power outlet free from any variation that may cause the voltage to exceed the tolerable voltage range.

3.2.7.1 Cable to Be Used

Use a two conductor cable with a finished OD of 9 to 12mm.

3.2.7.2 Connecting Procedure

(1) End-treat the cable.

Strip off about 40 mm of the insulation from the cable end and attach crimping terminal lugs conforming to an M3 screw to the tip of each conductor.

(2) Connect each cable conductor to terminals 1 and 2.

When introducing the cable into the converter, remove the parts attached to the cable gland located at cable inlet C and pass the cable through these parts in the proper sequence in advance.

(3) Fix the cable.

Adjust the length of the portion of the cable housed within the converter and fix the cable by reassembling the parts through which the cable passes to the cable gland. After connection to the external wiring terminals described in Subsections 3.2.1 to 3.2.7 is completed, mount the terminal cover.

3.2.8 Ground Wiring

The grounding terminal is located on the left side of the case, as shown in Figure 3.10. Ground the terminal using a wire having a nominal cross section of 2 mm² or more, complying with JIS class 3 grounding (the ground resistance must be 100 Ω or less). The terminal screw is M4-threaded. Attach a crimping terminal lug matching the M4 screw to the tip of the wire.

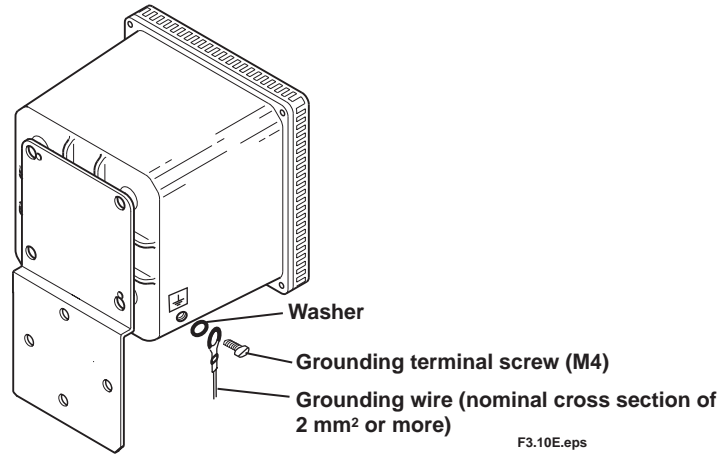

Figure 3.10 Grounding Terminal



If grounding is not possible from the converter case, ground the converter at the power supply using the power cable conductor. In this case, use a three-conductor cable or a two conductor shielded cable for power-supply wiring and connect the grounding conductor to terminal \perp (for grounding) in the converter.

4. Operation

This chapter describes the operation of the ORP Metering System by mainly referring to the operating procedures for the OR400G ORP Converter.

4.1 Preparing for Operation

Ready for operation all equipment composing the ORP Metering System. For details on equipment other than the ORP converter, see their respective separate instruction manuals.

4.1.1 Checking the Conditions in Which Converter is Installed, Piped and Wired

● Inspection of Installation

- (1) Check that the ORP sensor is ready for measurement (see the appropriate instruction manual) and the holder is securely fixed.

● Inspection of Wiring

- (1) Check that all necessary wiring has been completed and the cables are properly connected. After checking the connection to the ORP converter, be sure to mount the terminal cover.
- (2) Check that all unused cable inlets are plugged with a blind.

● Inspection of Piping

The types of piping include sampling piping (when a flow-through type holder is used) and cleaning utility piping (when a holder with a jet or brush cleaner is used). In some applications where an OR8EFG ORP Sensor is used, an air pipe for pressurizing the KCl reservoir tank may be installed. Likewise, in some applications where a 797M Detachable Holder is used, a steam pipe for sterilization may be installed.

- (1) Check that all necessary piping has been completed.
- (2) If a flow-through type holder is used, check that the specifications of the pipe (material, diameter, etc.) conform to the requirements of the measured solution that flows through the pipe (flow rate, pressure, temperature, etc.).
- (3) If a holder with a jet or brush cleaner is used, check that piping is provided that supplies the cleaning utility (water and air) at a specified pressure.

4. Operation

4.1.2 Supply of Power

First, confirm that connected control equipment is not being operated from a signal from the ORP converter. Then, turn on the switch provided on the power line to bring the converter into operation. Turning on the power causes the converter to start operating in the measurement mode.

● Main Actions in Measurement Mode (depend on the parameters set upon shipment from the factory)]

- (1) The measured ORP value (mV) appears in the data display and the output current of the signal (mA) in the message display.
- (2) Output signals of 4 to 20 mA DC corresponding to the measurable range (-1500 to 1500 mV) are sent out.
- (3) If the ORP converter detects a failure, it delivers the FAIL contact output (contact is "closed").



Tip

The FAIL contact is also "closed" during power off.

If a failure is detected, the output signal is held at the value immediately before.

4.1.3 Check of Setting Parameters and Changes in Their Default Values

Set up relevant parameters to meet individual operating requirements. In the case of critical parameters, confirm that they are given correct settings even if the values set upon shipment from the factory (default values) are to apply without change.



If a holder with a cleaner is used, re-set the cleaning timer at "Execute." If default values have been changed, it is convenient to record the data in the "Notes on Operation Parameter Settings," for example, attached at the end of this manual.

The types and functions of setting parameters are detailed in Chapter 5. Refer to this information before you start setting parameters. For reference, the pages describing the main setting parameters and key operations are shown below.

[Key Operation Procedures]

Basic patterns of key operation	(page 1-3)
Switching from measurement mode to setting level	(page 1-4)
Selecting numeric values and digits (data entry).....	(page 1-5)
Aborting setting operation (returning to measurement mode)	(page 5-2)
Moving through setting items en the setting level.	(page 5-6)
Selecting setting parameters on the service level.	(page 5-13)

[Output Signal]

Changing the measuring range	(page 5-9)
Holding the output signal (during calibration, cleaning or maintenance) ..	(page 5-10)
Output signal "Burn-up/burn-down" (at occurrence of FAIL signal).....	(page 5-14)
Shutting down transmission of output signals	(page 5-15)

[Contact Output]

Execution of automatic cleaning	(page 5-11)
Providing alarm setpoints	(pages 5-8, 5-16 and 5-17)
Setting delay time and hysteresis	(page 5-18)

[Specifications of Combined ORP Sensor]

Entering types of reactive elements (metal = platinum/gold, antimony) ..	(page 5-20)
--	-------------

4.1.4 Electrode Checkup and Calibration

Using a checkup solution, check the electrode to ensure that the ORP sensor is normal.



Electrode Checkup and Calibration

Normally, an ORP meter is used for the purpose of, for example, knowing the end of a reaction in a process where absolute values are not a concern. In such an application, there is no problem in using the ORP meter even if there is a slight difference between the reading given by the electrode and the true ORP value. However, dirt accumulating on the wetted part or reactive element not only affects the emf of the electrode adversely but also causes other problems, such as the degradation of responses. It is, therefore, advisable that the electrode be cleaned at regular intervals so it is maintained in excellent condition. Electrode checkup (examination of the emf is carried out to determine whether the electrode is in need of maintenance (cleaning of the wetted part or reactive element) or not. Calibration, on the other hand, is carried out to correct the output value for a case where, because of a degraded electrode, the emf slightly exceeds the tolerable limit even after maintenance.

Note: If the emf largely exceeds the tolerable limit, the electrode may have reached the end of its service life. An electrode failure is suggested by the indication of error code E2 on the display (if CODE 03 of the service level is applied to turn on the checking for asymmetric potential).

Calibration is also carried out to tune the measured value of this system to that of another system.

4.1.4.1 Reagent and Apparatus Arrangements

When carrying out an electrode checkup and calibration, provide the following equipment and materials.

- Reagent for Preparing Checkup Solution

Use this chemical if a checkup solution (a chemical with a known ORP value) is not readily available. Prepare a quinhydrone reagent or a ferrous reagent. When using a ferrous reagent, approximately 15 ml of concentrated sulfuric acid is also needed (when 250 ml of checkup solution are being prepared).

Note: The following chemicals are available as reagents from the manufacturer.

Quinhydrone reagent	: Part number K9024EC (for preparing 250 ml solution, three bags)
Ferrous reagent	: Part number K9024ED (for preparing 250 ml solution, three bags)

- Wide-mouth 250 ml Beaker

Used to prepare a checkup solution with a quinhydrone or ferrous reagent.

- 200 ml Beaker

Used to submerge the ORP electrode in the checkup solution.

- Thermometer

Used to measure the temperature of the checkup solution.

4.1.4.2 Procedure for Electrode Checkup/Calibration

See Chapter 6.

4.1.5 Operation Check

When an electrode checkup (or manual calibration) is complete, return the ORP sensor and other equipment to where they were installed initially for system operation. Place all the equipment configuring the measurement loop in operation. Continue doing a test run for a while. After confirming that there are no problems in the entire system, place it in steady operation. For reference, the following summarizes the setting functions (signals) of the OR400G ORP Converter used to obtain optimum operating conditions.

4.1.5.1 Functions Related to Output Signal

- Normally, the output signal is held at the value immediately before or at a desired value during calibration or cleaning or in the setting/service level. This is to prevent the output signal from adversely affecting the operation of the equipment configuring the measurement loop (default setting: the output signal is held at the value immediately before). A signal hold can be canceled to have the system output real-time signals (actual measured values). (See item 5.3.1.3 on page 5-10.)
- The output signal can be either "Burned up" (fixed to 22 mA DC) or "Burned down" (fixed to 3.6 mA DC) if, for example, the signal needs to be identified from a normal one when a FAIL contact signal is generated (default setting: no "burn-up/down"). (See CODE 05 on page 5-14.)
- If necessary, you can shut down (fixed to 3.6 mA DC) the transmission of the output signal in the measurement mode. (See CODE 12 on page 5-15.)

4.1.5.2 Functions Related to High/Low-limit Alarm Contact Output

If control is improper, the delay time and hysteresis can be changed (default setting: delay time of 0.2 second, hysteresis of 0.10 mV). (See CODE 17 on page 5-18.)

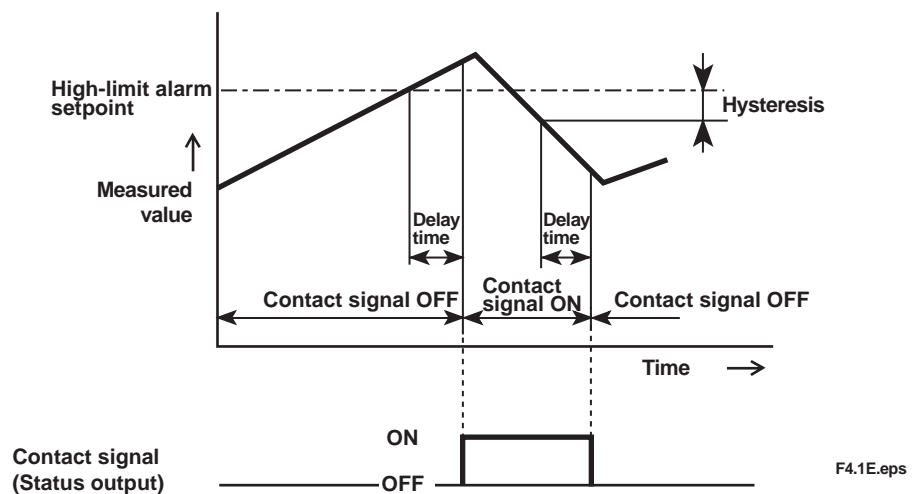

Figure 4.2 Delay Time and Hysteresis for Alarm Contact Output (example of high-limit alarm)

4. Operation

4.1.5.3 Functions Related to Cleaning Contact Output

If, in an application where a holder with a cleaner is used, the cleaning timer is set to "execute" (default setting: stop), automatic cleaning is carried out with the timing shown in Figure 4.3. However, automatic cleaning is not executed unless the converter is set in the measurement mode.

The cleaning period (default setting: 10 hours) and cleaning time (default setting: 0.1 minute) can be changed depending on the property of the measured solution so that the sensor will be able to receive sufficient cleaning.

The relaxation time (default setting: 0.2 minute) is the interval for holding an output signal until the measured value becomes unaffected by the cleaning utility after cleaning is completed. This is effective only when the output signal hold is set "execute." If cleaning is aborted with the [MODE] key, the relaxation time is deleted. The harm resulting from the effects exercised by the cleaning utility upon measured values can be known by turning on the function to check the return-to-half-value time of CODE 21 in the service level (default setting: OFF). When this function is active, an E11 error will result if the converter fails to return to a half value within the allowable time range. Consequently, the FAIL contact signal turns on. To cancel the error, select CODE 25 in the service level.

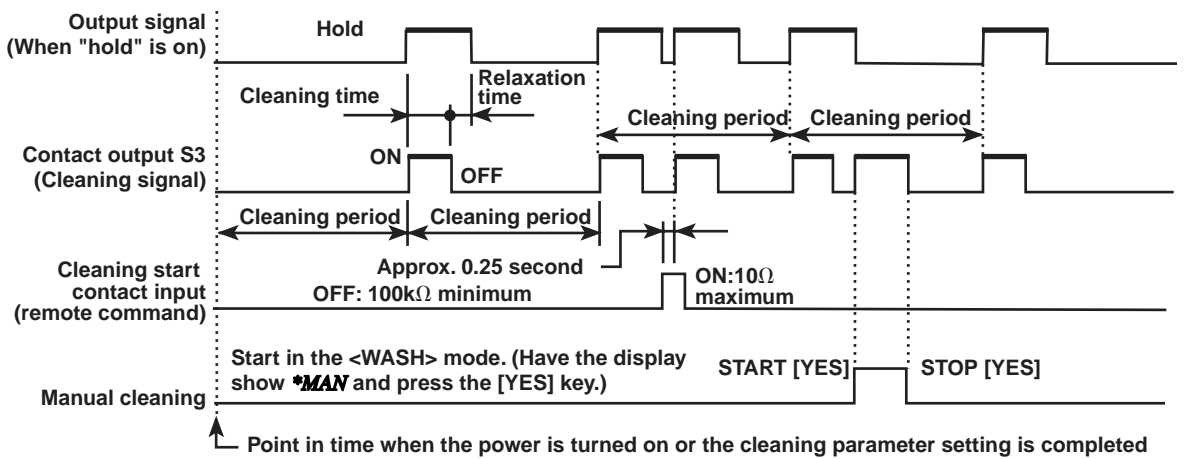

- The cleaning time does not reset even if cleaning started with the remote cleaning start command.
- Pressing the [MODE] key during the cleaning time immediately enters the measurement mode.
- Cleaning continues even if the FAIL contact output turns on during the cleaning time. However, cleaning does not start even if the cleaning start time is reached when the FAIL contact output is on.

Figure 4.3 Output Timing of Cleaning Contact Signal S3 and Holding of Output Signal

Procedure for Canceling "E11" Error (Error in Return-to-half-value Time)

An "E11" error can be canceled by key operation at CODE 25 on the service level. (Errors other than "E11" cannot be canceled unless the system recovers to normal operation.)

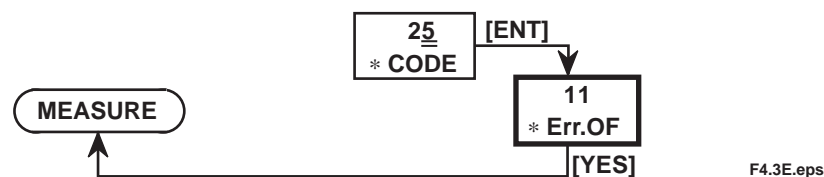

4.2 Steady Operation

Normally, it is not necessary to adjust the OR400G ORP Converter except when you check the electrode periodically. In principle, also check and service the sensor when you check the electrode. This is not true, however, if any failure should occur meanwhile.

4.2.1 Corrective Actions Against Failure

If the OR400G ORP Converter detects a failure, the FAIL contact output turns on. If the "Burn-up/down" function is active, the output signal either "burns up" (current output: 22 mA) or "burns down" (current output: 3.6 mA). The content of the failure is given in the data display through an error number. If a failure occurs, confirm the details of the failure and take prompt corrective action. Table 4.1 summarizes the error numbers for failures occurring in the measurement mode. For details on each failure, see Section 8.2.

Table 4.1 Failures Occurring in Measurement Mode

Error No.	Cause of Failure	Corrective Action
E9	Failure in measured value (out of the range from -1500 to 1500mV)	Check the sensor cable for any failure
E10	Detection of EEPROM memory check error	Request repair by YOKOGAWA
E11	Failure in return-to-half-value time	Check the electrode
E20	Failure in initially adjusted data values	Request repair by YOKOGAWA

T4.1E.eps

4.2.2 Inspection and Maintenance

Check the electrode of the ORP sensor at such intervals that the emf does not exceed the tolerable limits. A period of one to three months is the recommended interval. Clean the ORP sensor and the wetted part of the holder also when you check the electrode.

4.3 Shutdown and Restart

4.3.1 Measures for Shutdown

Data set in the converter are retained even when the power is turned off. If the system needs to be shut down over a prolonged period, turn off the power. If the ORP sensor is dismantled at that time, completely remove any dirt from the sensor (for more information, see the instruction manual for the ORP sensor).

4.3.2 Measures for Restarting

When the power is turned on again, the ORP converter goes into the measurement mode. Check the electrode before you start measurement. (For measures taken at the restart of equipment other than the ORP converter, see their respective separate instruction manuals.)

5. Parameter Setting

When using the OR400G ORP Converter, set data and select functions according to your purpose of use and the measuring conditions. This chapter describes the parameter setting procedures.

5.1 Setting Operation Summary

5.1.1 Operation, Setting and Service Levels

Parameters can be set by selecting the appropriate mode. These modes are classified into three levels; the operation, setting and service levels.

[Operation Level]

This is basically a level used to perform operations relating to routine inspection and/or maintenance (manual calibration, electrode checkup, etc.). Key operations can be done externally with the front cover mounted only at this level. This level allows selection of items appearing on the message display.

[Setting Level]

There are modes at this level for setting data related to output signals and contact outputs.

[Service Level]

The OR400G ORP Converter has a number of functions. At this level, there are modes to select the functions necessary for system operation.

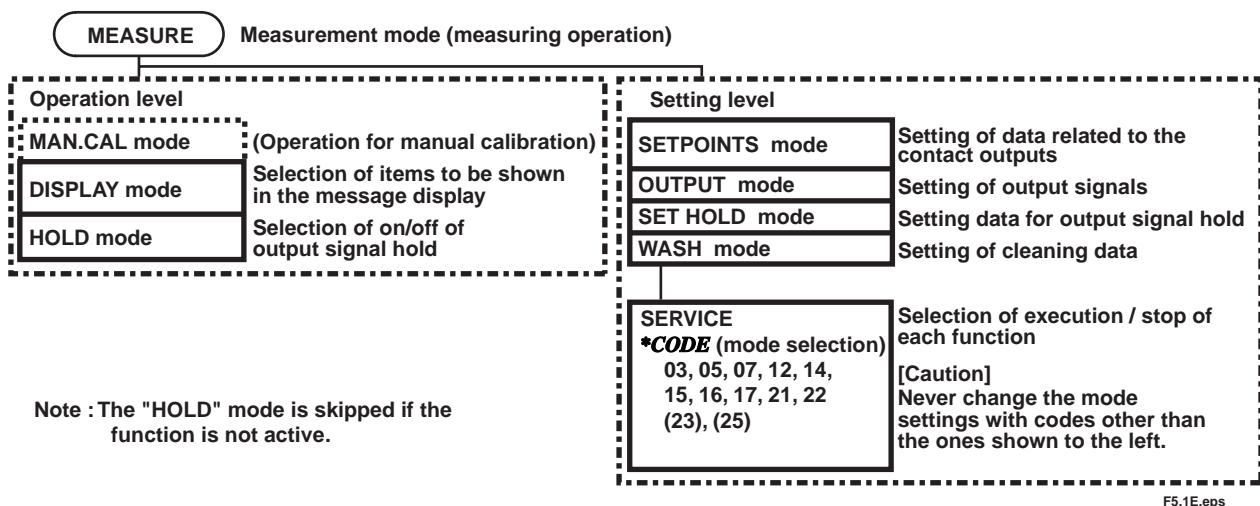

Figure 5.1 Classification of Modes Related to Level Settings

5.1.2 Key Operations

Keys can be operated in an "interactive" manner. Operate the keys according to the information in the data or message display, information pointed to by the pointer (mode indication), and/or information in the key operation display. For basic key operations, see Chapter 1.

5.1.2.1 Interactions

- Flashing pointer

This inquires whether you want to go to the mode being pointed at or move the pointer to the next mode. When the system indicates the modes for the setting or service level, the message is preceded by an asterisk (*). When you enter one of the modes, the pointer stops flashing and remains continuously lit.

- Flashing key operation display

Select from the items shown in the display and press the corresponding key.

- Flashing data display (numerals)

This inquires whether you want to change the flashing numeral or move to the next digit and have it flash. Press the appropriate key. If neither of these actions is required, press the [ENT] key.

5.1.2.2 Aborting Setting Operation (Returning to Measurement Mode)

Press the [MODE] key.

Normally, the [MODE] key is used to move from the measurement mode to a mode at the operation level. If the [MODE] key is operated in a mode other than the measurement mode, the converter operates in the measurement mode. If the output signal hold function is active at that time, the converter goes into the "hold selection" mode at the operation level.

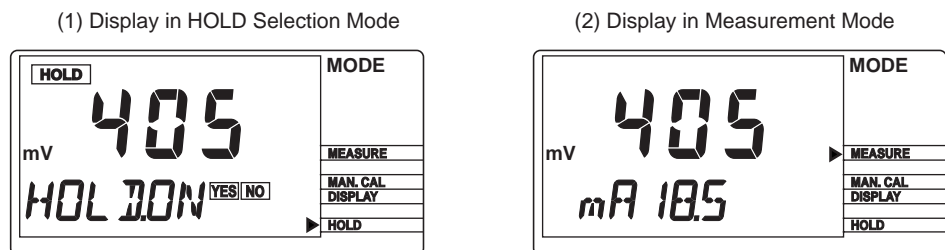

In the "hold selection" mode, **HOLD.ON** appears in the message display and **YES** and **NO** in the key operation display flash. If the current status is "hold", **HOLD** appears also in the display.

Pressing either the [YES] or [NO] key in the display shown in (1) goes to the measurement mode.

F5.2E.eps

Figure 5.2 Displays When [MODE] Key is Pressed in Mode Other Than Measurement Mode

5.1.2.3 Automatic Return to Measurement Mode

If no key operation is performed for 10 minutes, the converter in maintenance operation automatically returns to the measurement mode. If the converter is in the <MAN.CAL> mode, however, this time is one hour. This automatic return is effective only when the function is on; no automatic return takes place otherwise.

5.1.3 Points to be Noted in Implementing Setting

If any change has been made to a particular data item, check its relationship with data items set in other modes so that there will not be any inconsistency.

(1) Items to Check When the Measuring Range Is Changed]

- a. High/low-limit (high-high/low-low-limit) alarm setpoints and contact output hysteresis
- b. Fixed value for output signal hold

(2) Item to Check When Cleaning Function is Changed from "Stop" to "Execute"

- a. Setting of "execute/stop" of return-to-half-value time check

(3) Items to Check When High/Low-limit (High-high/Low-low-limit) Alarm Setpoints are Changed

- a. Measuring range
- b. Alarm actions (low-limit alarm or high-limit alarm operation)
- c. Delay time and hysteresis

5.2 Setting Items

Subsections 5.2.1 to 5.2.3 show the setting items for each level.

5.2.1 Setting Items at Operation Level

Table 5.1 Setting Items at Operation Level

Mode / Setting Item	Display	Remarks	Default
MAN.CAL (Operation for manual calibration)	MAN.CAL	—	—
DISPLAY Selection of Items to be shown in the message display	DISP	(Pressing the [YES] key enters this mode)	(See page 5-7)
	mA XX.X mV 250 XXX AS XX RZ RES XX	Output signal given as a current (This function is not used.) Output current (This function is not used.) (This function is not used.)	Asymmetric Potential
HOLD Output signal hold selection mode	HOLD	(Pressing the [YES] key enters this mode)	
ON / OFF	HOLD.ON	Press the [YES] key to turn on. Press the [NO] key to turn off.	(See page 5-7)

(Note) ● The output signal hold selection mode is skipped if "***HOLD.OF**" is selected in the hold parameter setting mode at the setting level.

[Remarks] The "Display" column lists the items as they appear on the message display.
"X" in the "Display" column indicates an unspecified numeral.

T5.1E.eps

5. Parameter Setting

5.2.2 Items Set at Setting Level

Table 5.2 Items Set at Setting Level

Mode / Setting Item	Display	Remarks (conditions)	Default
SETPOINTS Alarm point setting mode	* SET.P	(Pressing the [YES] key enters this mode)	(See page 5-8)
Alarm point setting of contact output S1	*SETP.1	-1500 to 1500[mV]	(500 [mV])
Alarm point setting of contact output S2	*SETP.2	-1500 to 1500[mV]	(-500 [mV])
Alarm point setting of contact output S3	*SETP.3	-1500 to 1500[mV]	(250 [mV])
Low-low-limit alarm point setting of contact output S3	*S3.LOW	-1500 to 1500[mV]	(-1000 [mV])
High-high-limit alarm point setting of contact output S3	*S3.HIGH	-1500 to 1500[mV]	(1000 [mV])
OUTPUT Measuring range setting mode	*OUTPUT	(Pressing the [YES] key enters this mode)	(See page 5-9)
Minimum value setting in the measuring range	*4mA	-1500 to 1500[mV]	-1500[mV]
Maximum value setting in the measuring range	*20mA	-1500 to 1500[mV]	1500[mV]
SETHOLD Hold parameter setting mode	*SET.HD	(Pressing the [YES] key enters this mode)	(See page 5-10)
Selection of "ON/OFF" of hold	*HLD.OF *HLD.ON	Press the [YES] key to turn the hold off Press the [YES] key to turn the hold on	"ON"
Selection of the value immediately before holding or the fixed value	*HD.LST *HD.FIX	Press the [YES] key to select the value immediately before holding. Press the [YES] key to select the fixed value	Value immediately before holding
Current-signal level of the fixed value	*HLD.mA	4.0 to 20.5 mA	(12.0 [mV])
WASH Cleaning parameter setting mode	*WASH	(Pressing the [YES] key enters this mode)	(See page 5-11)
Selection between "automatic cleaning /manual cleaning"	*AUTO *MAN	Press the [YES] key to select automatic cleaning Press the [YES] key to select manual cleaning	("Automatic" cleaning)
Selection between "ON/OFF of cleaning timer"	*T.OFF *T.ON	Press the [YES] key to turn off the timer Press the [YES] key to turn on the timer	"OFF"
Cleaning period	*INT.H	0.1 to 36.0 [h]	(10.0 [h])
Cleaning time	*WT.min	0.1 to 10.0 [min]	(0.1 [min])
Relaxation time	*RT.min	0.1 to 10.0 [min]	(0.2 [min])

T5.2E.eps

(Note) ● The contact outputs S1,S2and S3 are all turned off with CODE14,CODE15 and CODE16 at the service level.

[Remarks] The values in parentheses under "Default" become effective only when their respective functions are tuerned on.

5.2.3 Items Set at Service Level

At the service level, you can select the appropriate code number to mode.

Table 5.3 Items Set at Service Level

Mode / Setting Item	Display	Remarks (conditions)	Default
CODE03 Mode for setting asymmetric potential check function	* CODE	(Typing "03" enters this mode.)	(See page 5-14)
Selection between "ON/OFF"	* CHECK	0.X.0: OFF 1.X.0: ON	1.X.0
CODE05 "Burn-up / down" function setting mode	* CODE	(Typing "05" enters this mode.)	(See page 5-14)
Selection between "ON/OFF"	* BURN	0: OFF 1: Burn-up 2: Burn-down	0
CODE07 Mode for setting automatic return to measurement mode	* CODE	(Typing "07" enters this mode.)	(See page 5-15)
Selection between "ON/OFF"	* RET.	0: OFF 1: ON	1
CODE12 Mode for setting output signal transmission	* CODE	(Typing "12" enters this mode.)	(See page 5-15)
Selection between "ON/OFF"	*mA.COD	0: OFF 1: ON	1
CODE14 Mode for setting the function of contact output S1	* CODE	(Typing "14" enters this mode.)	(See page 5-16)
Selection of function	*S1	0.0: OFF 1.X: Low-limit alarm 2.X: High-limit alarm 3.0: Hold X.0: Status X.1: (Unused) X.2: (Unused)	0.0
Type of high / low-limit alarm output			
CODE15 Mode for setting the function of contact output S2	* CODE	(Typing "15" enters this mode.)	(See page 5-17)
Selection of function	*S2	0.0: OFF 1.X: Low-limit alarm 2.X: High-limit alarm 3.0: Hold X.0: Status X.1: (Unused) X.2: (Unused)	0.0
Type of high / low-limit alarm output			
CODE16 Mode for setting the function of contact output S3	* CODE	(Typing "16" enters this mode.)	(See page 5-17)
Selection of function	*S3	0.0: OFF 1.X: Low-limit alarm 2.X: High-limit alarm 3.0: Hold 4.0: Cleaning 5.0: High-high limit / Low-low limit X.0: Status X.1: (Unused) X.2: (Unused)	0.0
Type of high / low-limit alarm output			
CODE17 Mode for setting delay time and hysteresis of alarm contact output	* CODE	(Typing "17" enters this mode.)	(See page 5-18)
Delay time setting	*D.TIME	0.1 to 19.9 [s]	(0.2[s])
Hysteresis setting	*HYST	0 to 1500 [mV]	(10[mV])
CODE21 Mode for setting return-to-half-value time check function	*CODE	(Typing "21" enters this mode.)	(See page 5-19)
Selection between "ON/OFF"	* HT.CHK	0: OFF 1: ON	0
Return-to-half-value time setting	* HT.min	0.1 to 10.0 [min]	(0.1[mV])
CODE22 Mode for setting type of electrode's reactive element	* CODE	(Typing "22" enters this mode.)	(See page 5-20)
Setting of reactive element	* Sb.SEN	0: precious metal (platinum or gold) 1: antimony	0

T5.3E.eps

[Remarks] The values in parentheses under "Defaults" become effective only when their respective functions are tuned on.

5.3 Setting Procedures

The setting mode can be selected by moving and positioning the pointer or by cycling through the menu items on the message display.

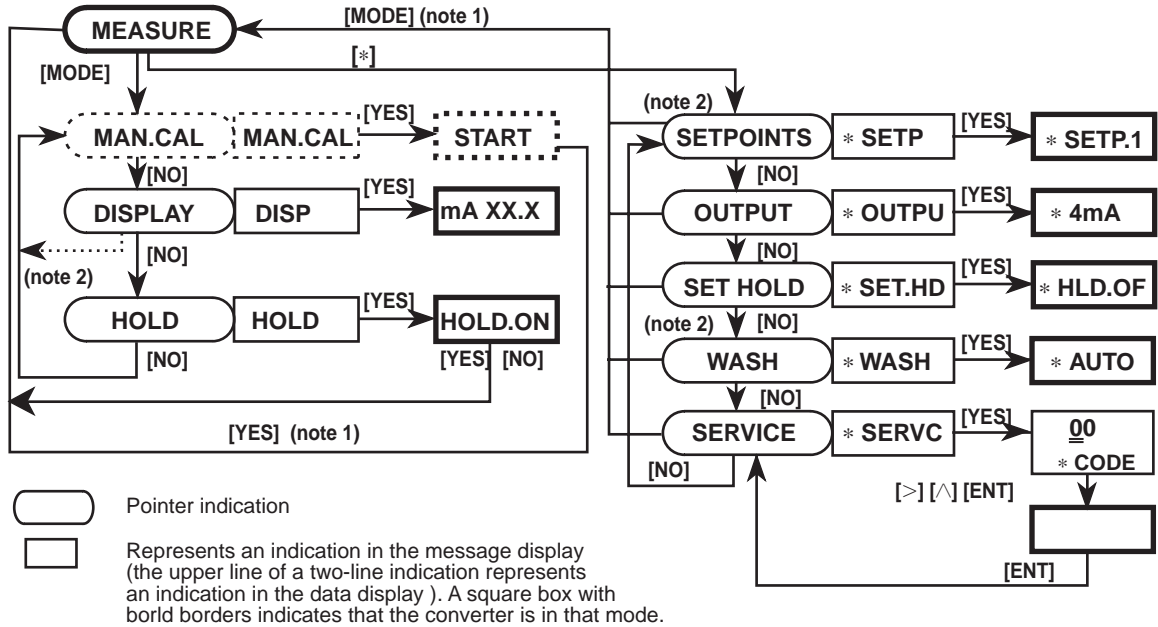

- (note 1) Under a specific condition, this operation may switch to the hold setting mode of the operation level.
- (note 2) Skipped if the corresponding function is turned off.

F5.3E.eps

Figure 5.3 Switching Between Setting Modes

5.3.1 Parameter Setting at Operation Level

The operation level offers two categories of modes: the setting and calibration operation modes. This subsection explains only the operating procedures used in the setting mode (DISPLAY and HOLD).

The calibration operation (MAN.CAL) mode is discussed in Chapter 6.

5.3.1.1 DISP Mode for Selecting Items to be Shown in the Message Display

This mode is used in the measurement mode to select items to be shown in the message display. There are five items for selection, as shown below. Each pressing of the [NO] key moves from one item to another. Note that three of the parameters, the output signal given as a voltage, reference electrode impedance and 90 % response time, are not used in this system. Consequently, values given for these parameters have no significance.

1. *mA XX.X* : Output signal given as a current
2. *mV 250* : Output signal given as a voltage (This parameter is not used.)
3. *XX AS* : Asymmetric potential
4. *XX RZ* : Reference electrode impedance (This parameter is not used.)
5. *RES XX* : 90 % response time (This parameter is not used.)

Pressing the [YES] key while the desired item is on display enters that item. The converter then goes to the measurement mode (or the hold selection mode). The default setting is the output signal given as a current.

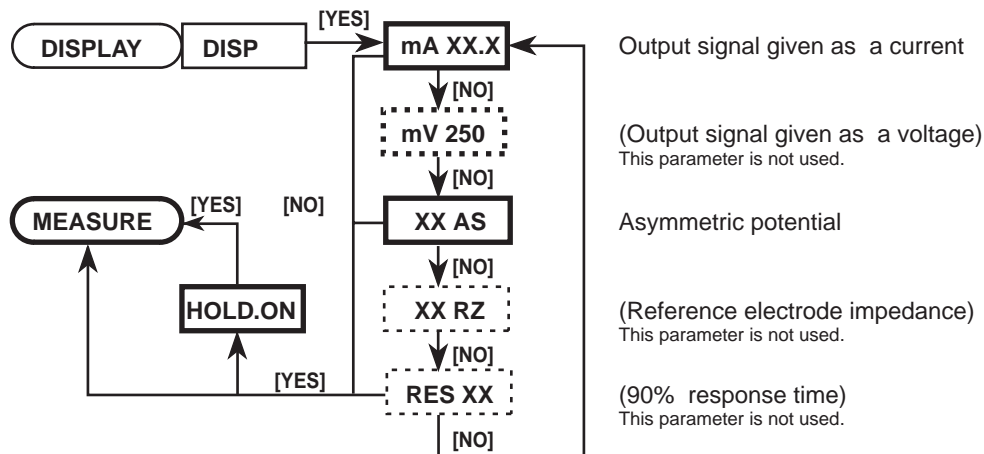

F5.4E.eps

Figure 5.4 Flow for Selecting Parameters to be Shown in the Message Display

5.3.1.2 HOLD Output Signal Hold Selection Mode

This mode is used in the measurement mode to determine whether the output signal should be held or not. This mode is effective when the hold function is set to "*HLD.ON" (turned on) in the hold parameter setting mode at the setting level. If the function is set to "*HLD.OF" (turned off), this mode is skipped.

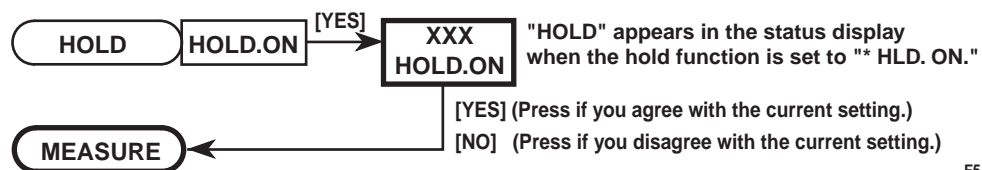

F5.5E.eps

Figure 5.5 Flow for Selecting On / Off Output Signal Hold

If the hold function is set to "*HLD.ON" (turned on) in the hold parameter setting mode at the setting level, the system is automatically set to this mode when it returns from any of the levels to the measurement mode.

5.3.2 Parameter Setting at Setting Level

The main task at the setting level is the setting of data values (measuring range, etc.). When setting parameters at this level, remove the front cover. Note that the function for which you have set a data value at the setting level does not work at all if that function is turned off at the service level. For this reason, care must be taken when dealing with modes that relate to each other. The setting level has the following four setting modes:

- (1) **SETP* Alarm point setting mode
- (2) **OUTPU* Measuring range setting mode
- (3) **SET.HD* Hold parameter setting mode
- (4) **WASH* Cleaning parameter setting mode

This subsection explains the setting procedures for modes (1) to (4) in the sequence in which keys are operated to select these modes.

5.3.2.1 **SETP* Alarm Point Setting Mode

Set alarm point values when contact outputs S1, S2, and S3 are set for a high-limit, low-limit, high-high-limit or low-low-limit alarm within CODEs 14, 15 and 16 at the service level. If none of these contact outputs are set for an alarm, skip this mode. The defaults for CODEs 14, 15 and 16 at the service level are all set to "OFF." Figure 5.6 shows the operation flow in the alarm point setting mode.

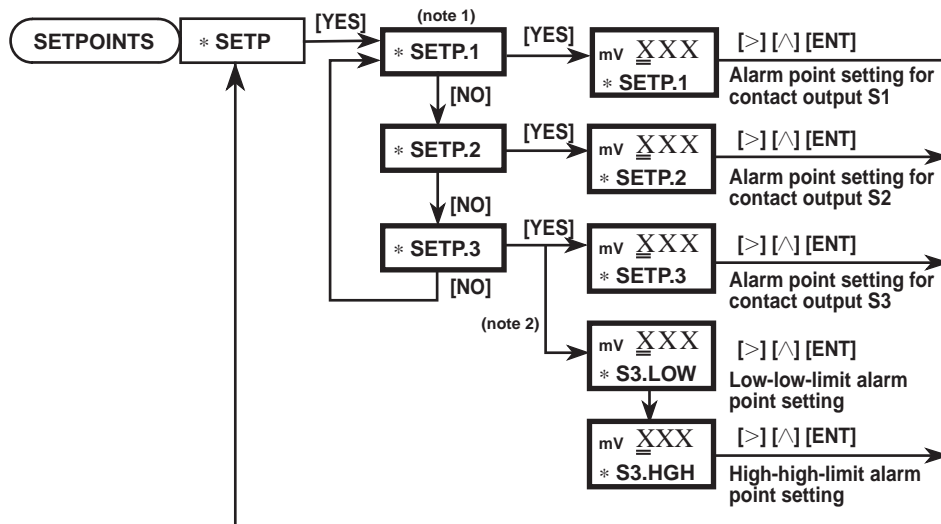

(note 1) : Items not set for the alarm are skipped.

(note 2) : This parameter appears when the high-high-limit or low-low-limit alarm is set in CODE 16.

F5.6E.eps

Figure 5.6 Flow for Operating with Output Signal Hold Setting Mode

The applicable range and factory-set default of each parameter in this mode are given as follows. Entering a value exceeding the limits causes a type "E19" error to occur.

- * *SETP.1* (setting upon shipment: 500 mV)
Setting range: -1500 to 1500 [mV]
- * *SETP.2* (setting upon shipment: -500 mV)
Setting range: -1500 to 1500 [mV]
- * *SETP.3* (setting upon shipment: 250 mV)
Setting range: -1500 to 1500 [mV]
- * *S3.LOW* (setting upon shipment: -1000 mV)
Setting range: -1500 to 1500 [mV]
- * *S3.HIGH* (setting upon shipment: 1000 mV)
Setting range: -1500 to 1500 [mV]

[Associated Setting Mode]

- Selection of alarm action: CODEs 14, 15 and 16 at service level
- Delay time and hysteresis: CODE 17 at service level

5.3.2.2 *OUTPU Measuring Range Setting Mode

Set the measuring range corresponding to the current-output signal (4 to 20 mA DC). Set the range by entering an ORP value appropriate for the minimum value of the output signal (4 mA) and the one appropriate for the maximum value (20 mA). Set the range such that the span is greater than 100 [mV]. If the span is smaller than the tolerable lower limit, a type "E17" error occurs. Figure 5.7 shows the flow for operating with the measuring range setting mode.

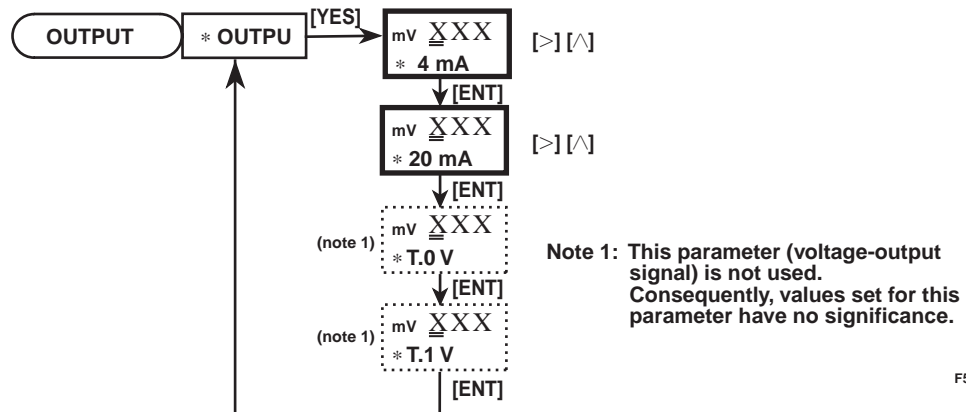

F5.7E.eps

Figure 5.7 Flow for Operating with Measuring Range Setting Mode

The applicable range and factory-set default of each parameter in this mode are given as follows. Entering a value exceeding the limits causes a type "E19" error to occur.

- * 4 mA (setting upon shipment: -1500 mV)
Setting range: -1500 to 1500 [mV]
- * 20 mA (setting upon shipment: 1500 mV)
Setting range: -1500 to 1500 [mV]

[Associated Setting Mode]

- On/off of output signal transmission: CODE 12 at service level

5.3.2.3 *SET.HD Hold Parameter Setting Mode

For the parameters for holding the output signal, determine:

- (1) Whether the hold function is turned on (*HLD.ON) or turned off (*HLD.OF).
- (2) Which value you choose when the hold function is turned on, the value immediately before holding (*HD.LST) or the fixed value (*HD.FIX).
- (3) At what value of current you want the output signal to be held when a fixed value is selected.

If the hold function is turned on, the output signal holds at a given value when the converter is set to the setting or service level or when automatic cleaning or calibration is carried out. Figure 5.8 shows the flow for operating with the hold parameter setting mode.

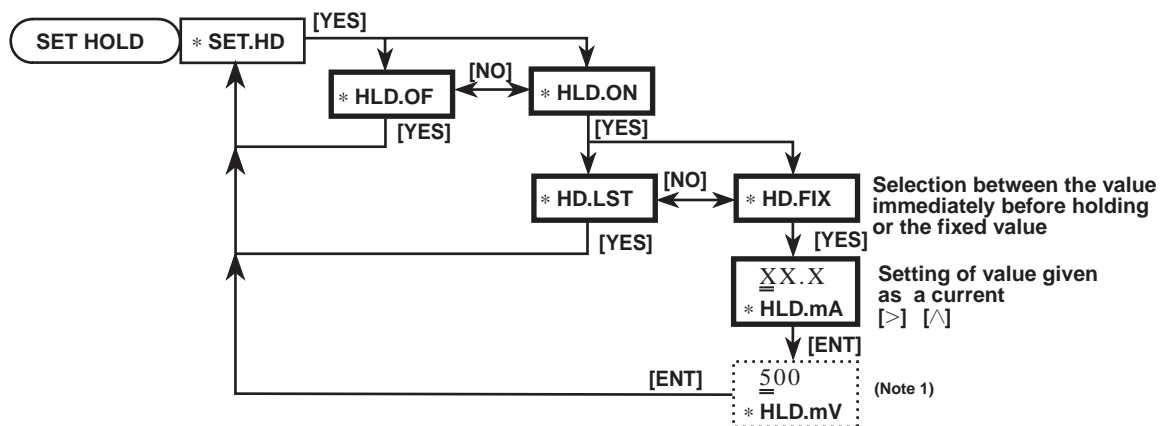

Note 1: This parameter (voltage-output signal) is not used.
Consequently, values set for this parameter have no significance.

F5.8E.eps

Figure 5.8 Flow for Operating with Hold Parameter Setting Mode

[Setting Procedures]

(1) Selection Between "ON (*HLD.ON)" and "OFF (*HLD.OFF)" of Hold Function

(Setting upon shipment: "ON")

When you enter the hold parameter setting mode, either * **HLD.OF** or * **HLD.ON** appears in the message display. If the message isn't the correct one, press the [NO] key to change to the other message and then press the [YES] key. If you have selected "ON" (*HLD.ON), the output signal hold selection mode at the operation level also turns on. The converter automatically goes into that mode when you return from the setting/service level to the measurement mode. (For more information, see item 5.3.1.2 on page 5-7.)

(2) Selection Between Value Immediately Before Holding (*HD.LST) or Fixed Value (*HD.FIX)

(Setting upon shipment; value immediately before holding)

If you select "ON" (*HLD.ON), either * **HD.LST** or * **HD.FIX** appears in the message display. If you want the output signal fixed at the value immediately before holding, press the [YES] key with the message * **HD.LST** (value immediately before holding) shown on the display. If you want the output signal fixed at any desired value, press the [YES] key with the message * **HD.FIX** (fixed value) shown on the display. If the current message is not what you want, press the [NO] key to change to another message and then press the [YES] key. If you have selected the value immediately before holding (*HD.LST), the hold function becomes active at this moment.

(3) Setting of Output Value Given as a Current (*HLD. mA)

(Setting upon shipment: 12.0 mA)

If you select the fixed value (*HD.FIX), the message display shows * *HLD. mA*, asking you to set an output value given as a current. Using the [>] or the [^] key, show the value being set in the data display, and then press the [ENT] key to enter it. Entering a value exceeding the following limits causes a type "E19" error to occur.

Setting range: 04.0 to 20.5 mA**5.3.2.4 * WASH Cleaning Parameter Setting Mode**

If you have configured contact output S3 to serve as a "cleaning" signal in CODE 16 at the service level, set the cleaning-related parameters in this mode. If you have otherwise configured the contact output, this mode is skipped. The cleaning-related parameters are the cleaning period, cleaning time and relaxation time (interval in which the output signal is held even after cleaning is complete so the measured value is not affected by the cleaning utility). In this mode, you can select between ON/OFF of the cleaning timer and use the operation for manual cleaning. For details on the cleaning operation, see the time chart shown in Figure 4.3 on page 4-6. Figure 5.9 shows the flow for operating with the cleaning parameter setting mode.

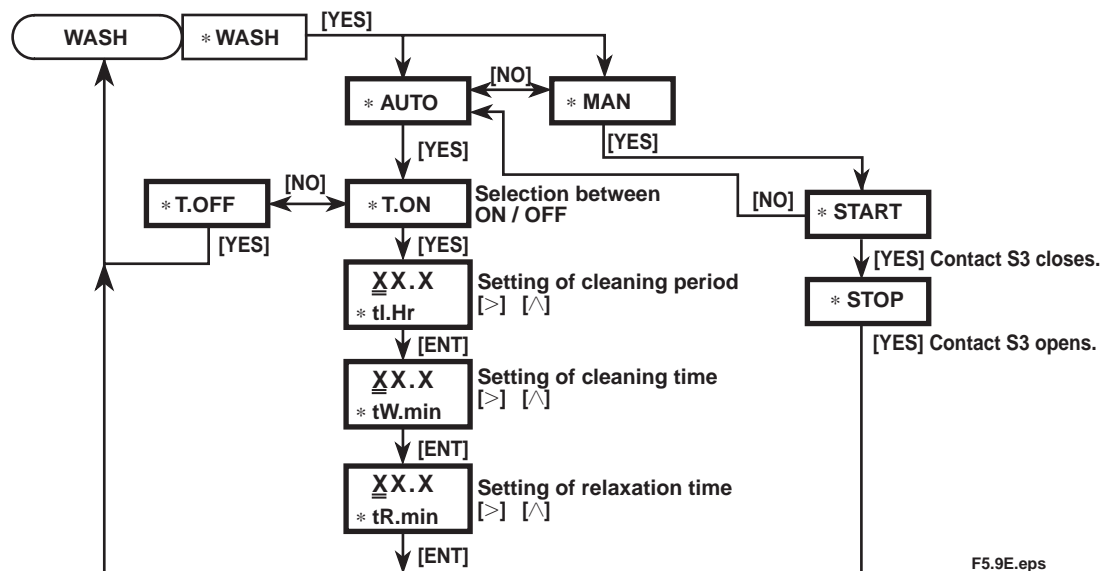

F5.9E.eps

Figure 5.9 Flow for Operating with Cleaning Parameter Setting Mode**[Setting Procedures]****(1) Selection Between Automatic Cleaning (*AUTO) and Manual Cleaning (*MAN)**

(Setting upon shipment: "Automatic Cleaning")

When you enter the cleaning parameter setting mode, either *AUTO or *MAN appears in the message display. In principle, select automatic cleaning (* AUTO) if a holder with a cleaner is used. Select manual cleaning (* MAN) when you carry out cleaning manually.

(2) Selection Between "ON" (*T.ON) and "OFF" (*T.OFF) of Cleaning Timer

(Setting upon shipment: "OFF")

If you select automatic cleaning (*AUTO), either [*T.OFF] or [* T.ON] appears in the message display. If you want automatic cleaning to be carried out in the measurement mode, press the [YES] key with the message [* T.ON] shown on the display. If the current message is not what you want, press the [NO] key to change to the other message and then press the [YES] key.

5. Parameter Setting

(3) Cleaning Period (*INT.H) Setting

(Setting upon shipment: 10.0 hours)

If you select "ON"(* T.ON), the message display shows **INT.H*, asking you to set the cleaning period. Set the cleaning period in hours. Using the [>] or the [Λ] key, show the value being set in the data display, and then press the [ENT] key to enter it. Entering a value exceeding the following limits causes a type "E19" error to occur.

Setting range: 0.1 to 36.0 h

(4) Cleaning Time (*WT.min) Setting

(Setting upon Shipment: 0.1 minute)

When you enter the cleaning period, ** WT.min* appears in the message display, asking you to set the cleaning time. Set the cleaning time in minutes. Using the [>] or the [Λ] key, show the value being set in the data display, and then press the [ENT] key to enter it. Entering a value exceeding the following limits causes a type E19 error to occur.

Setting range: 0.1 to 10.0 min

(5) Relaxation Time (*RT.min) Setting

(Setting upon shipment: 0.2 minute)

If you enter the cleaning time, the message display shows ** RT.min* asking you to set the relaxation time. Set the relaxation time in minutes. Using the [>] or the [Λ] key, show the value being set in the data display, and then press the [ENT] key to enter it. Entering a value exceeding the following limits causes a type "E19" error to occur.

Setting range: 0.1 to 10.0 min

Note that, if the hold function is set to OFF in the hold parameter setting mode, the output signal does not hold during the cleaning interval including the relaxation time.

5.3.3 Parameter Setting at Service Level

Enter the appropriate code number to go into each setting mode at the service level.



CAUTION

Do not enter codes other than those listed in Table 5.3 (page 5-5). Changing set data may impair normal operation of the converter. If you have entered a wrong code number by mistake, as a rule, return to the measurement mode by pressing the [MODE] key.

Note: If you have not changed the set data at all, you can exit that mode with the [ENT] key.

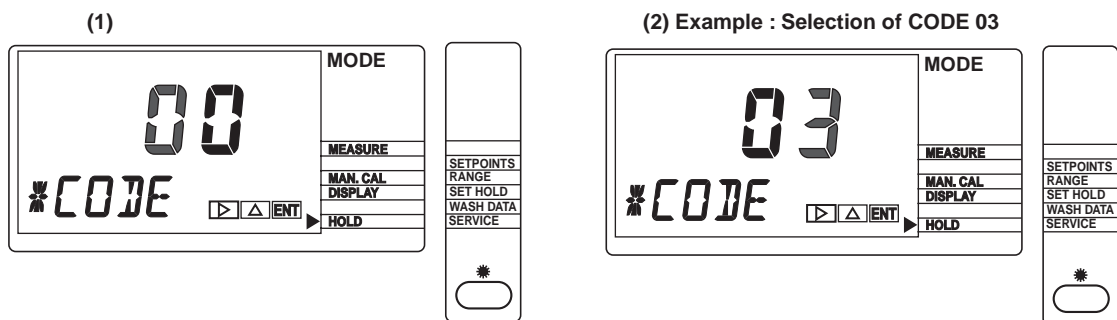

Pressing the [YES] key with *SERVC shown on the display switches to this display.

Pressing the [ENT] key with the desired code number shown on the display enters that code number. The display then changes to the one for setting mode.

F5.10E.eps

Figure 5.10 Example of Code Number Entry at Service Level

The setting procedures at the service level are described below in ascending order of the code numbers.

CODE 03 Mode for Setting Asymmetric Potential Check Function

The asymmetric potential check function determines, during calibration, whether or not the asymmetric potential is within the range from -120 to 120 mV. If the asymmetric potential falls outside the range, a type "E2" error occurs. In this mode, select between ON/OFF of the function. Figure 5.11 shows the flow for operating with the mode for setting the asymmetric potential check function.

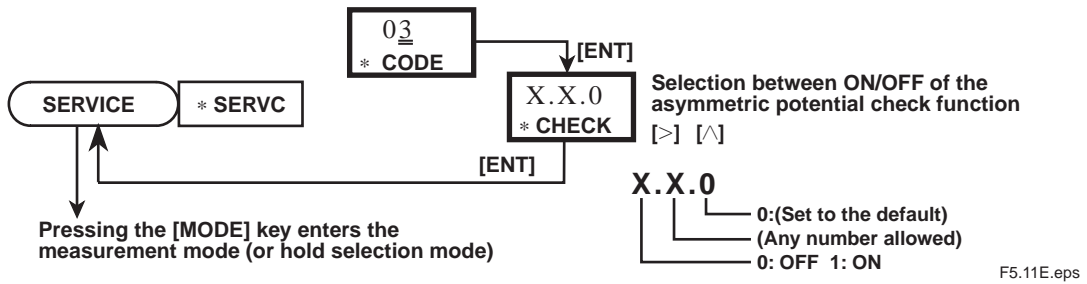

Figure 5.11 Flow for Operating with Mode for Setting Asymmetric Potential Check Function

CODE 05 Mode for Setting "Burn-up/down" Function

(Setting upon shipment: "0" [OFF])

The converter is provided with a function that causes the output signal to "burn up" to 22 mA or "burn down" to 3.6 mA if it detects a failure ("FAIL" appears on the display). In this mode, select either "ON" or "OFF" of the function and then either "burn up" or "burn down" .

Note: The maximum current due to overrange in normal operation is 20.5 mA.

If you enter CODE 05 to go into this mode, the message display shows [*BURN], The converter then asks you to select either ON or OFF of the "burn-up/down" function. If you have selected ON, it further asks you to select either "Burn up" or "Burn down." If you want the "burn-up/down" function turned off, press the [ENT] key with 0 shown on the data display. If you want the "burn up" function turned on, press the [ENT] key with 1 shown on the data display. If you want the "burn down" function turned on, press the [ENT] key with 2 shown on the data display. Figure 5.12 shows the flow for operating with the mode for setting the "burn-up/down" function.

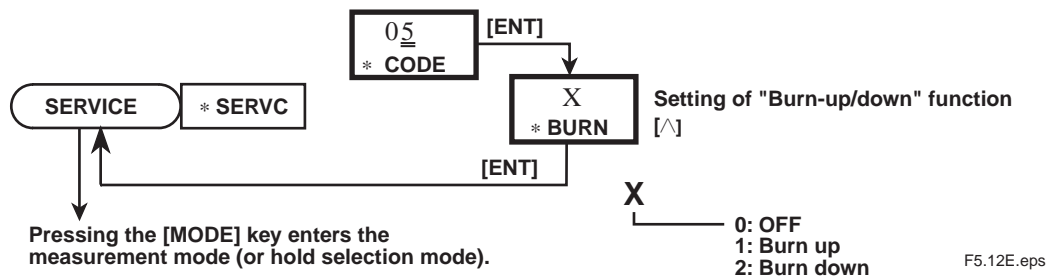

Figure 5.12 Flow for Operating with Mode for Setting "Burn-up/down" Function

CODE 07 Mode for Setting Automatic-return-to-measurement-mode Function (*RET.)

(Setting upon shipment: "1" [ON])

This mode allows the converter to automatically return to the measurement mode if no key operation is performed for 10 minutes (one hour, if the converter is under calibration) at each level. In this mode, select either ON or OFF of the automatic-return-to-measurement-mode function.

If you enter CODE 07 to go into this mode, the message display shows *RET. The converter then asks you to select either ON or OFF of the automatic-return-to-measurement-mode function. If you want the function turned off, press the [ENT] key with 0 shown on the data display. If you want the function turned on, press the [ENT] key with 1 shown on the data display. Figure 5.13 shows the flow for operating with the mode for setting this function.

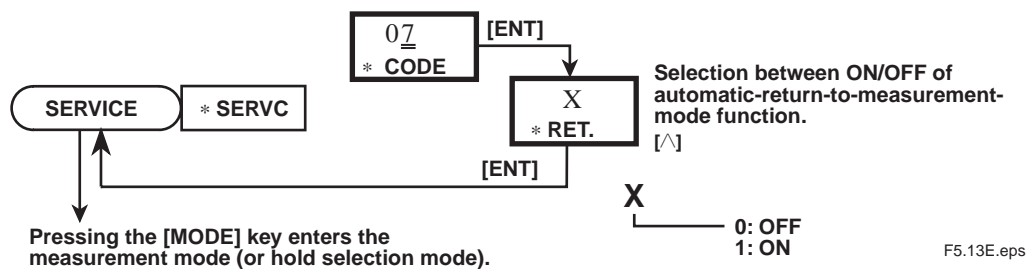

Figure 5.13 Flow for Operating with Mode for Setting Automatic- return-to-measurement-mode Function

CODE 12 Mode for Setting Output Signal Transmission Function (*mA. COD)

(Setting upon shipment: "1"[ON])

This function controls the transmission of a 4 to 20 mA DC output signal. If the function is set to OFF, the converter transmits a fixed signal of 3.6 mA. If the function is set to ON, the converter transmits a signal of 4 to 20 mA DC appropriate for the given measuring range.

If you enter CODE 12 to go into this mode, the message display shows *mA.COD. The converter then asks you to select either ON or OFF of the output signal transmission function. If you want the function turned off, press the [ENT] key with 0 shown on the data display. If you want the function turned on, press the [ENT] key with 1 shown on the data display. Figure 5.14 shows the flow for operating with the mode for setting this function.

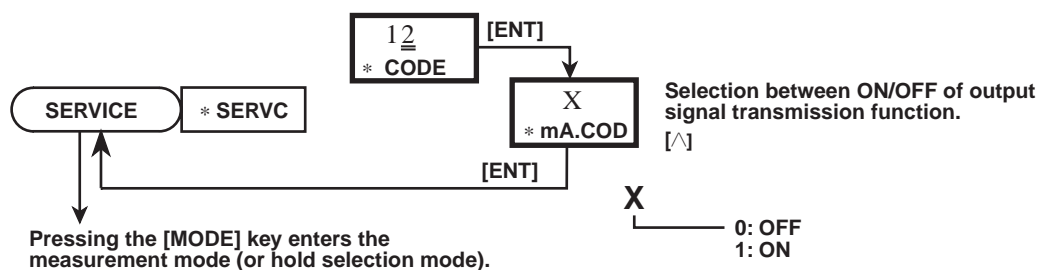

Figure 5.14 Flow for Operating with Mode for Setting Output Signal Transmission Function

CODE 14 Mode for Setting the Function of Contact Output S1

(Setting upon shipment: "0.0") .

Contact output S1 can be used as the high/low-limit alarm for a measured ORP value or as a "hold setting" signal. In this mode, select the function (low-limit alarm, high-limit alarm or "hold setting" signal) of the contact output, as well as the use or non-use of the contact output.



A "hold setting" signal is a signal that causes a relay contact to "open" when you have selected "holding ON" in the output signal hold selection mode at the operation level.

If you key in CODE 14 and press the [ENT] key, the message display shows * S1 . The converter then asks you to set the function of contact output S1. Show your desired function on the data display and press the [ENT] key. Figure 5.15 shows the flow for operating with the mode for setting the function of contact output S1.

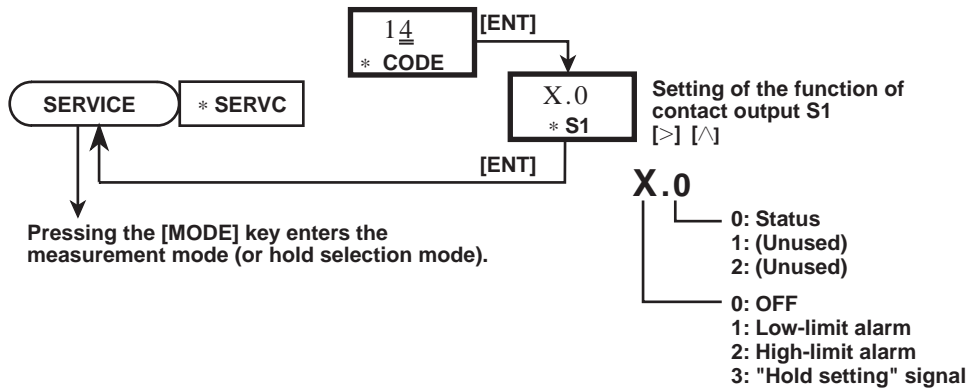

F5.15E.eps

Figure 5.15 Flow for Operating with Mode for Setting the Function of Contact Output S1

CODE 15 Mode for Setting the Function of Contact Output S2

(Setting upon shipment: "0.0")

Contact output S2 can be used as the high/low-limit alarm for a measured ORP value or as a "hold setting" signal. In this mode, select the function (low-limit alarm, high-limit alarm or "Hold setting" signal) of the contact output, as well as the use or non-use of the contact output, as in the case of CODE 14.

If you key in CODE 15 and press the [ENT] key, the message display shows * S2. The converter then asks you to set the function of contact output S2. Show your desired function on the data display and press the [ENT] key. Figure 5.16 shows the flow for operating with the mode for setting the function of contact output S2.

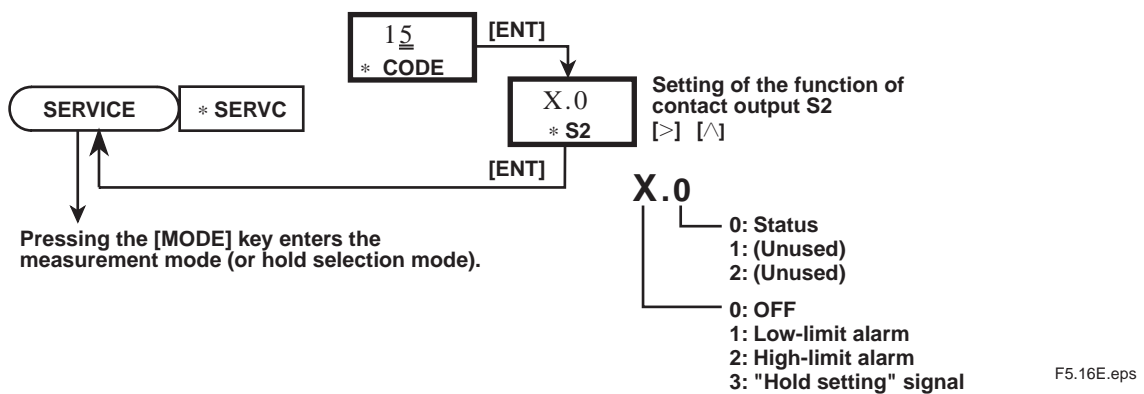

Figure 5.16 Flow for Operating with Mode for Setting the Function of Contact Output S2

CODE 16 Mode for Setting the Function of Contact Output S3

(Setting upon shipment; "0.0")

Contact output S3 can be used as the high/low-limit or high-high/low-low-limit alarm for a measured ORP value or as a "cleaning" or a "hold setting" signal. In this mode, select the function (low-limit alarm, high-limit alarm or "hold setting" signal) of the contact output, as well as the use or non-use of the contact output.

If you key in CODE 16 and press the [ENT] key, the message display shows * S3. The converter then asks you to set the function of contact output S3. Show your desired function on the data display and press the [ENT] key. Figure 5.17 shows the flow for operating with the mode for setting the function of contact output S3.

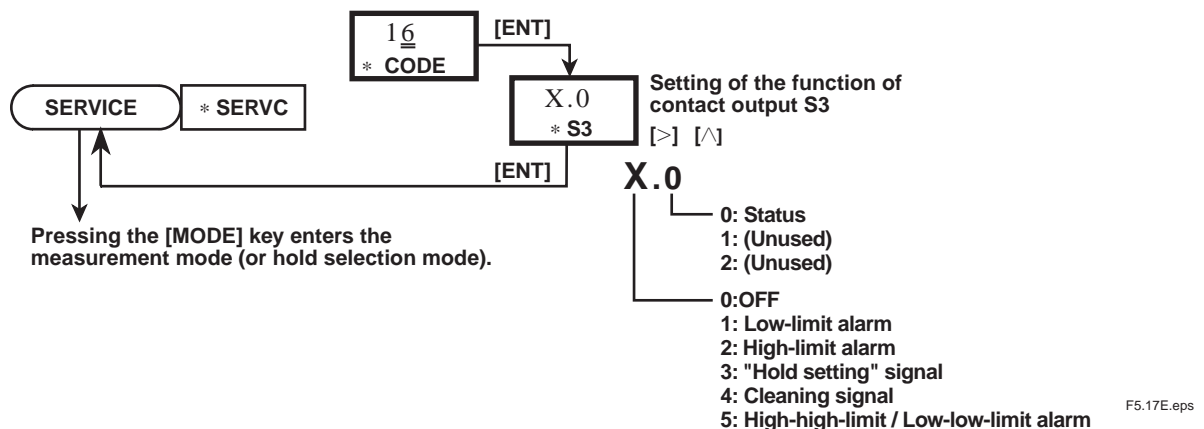

Figure 5.17 Flow for Operating with Mode for Setting the Function of Contact Output S3

CODE 17 Delay Time (*D.TIME) and Hysteresis (*HYST) Setting Mode

If the high/low-limit alarm (or high-high/low-low-limit alarm) is set with either CODE 14, CODE 15 or CODE 16, the delay time and hysteresis must also be set. Figure 5.18 takes a low-limit alarm as an example to show how the delay time and hysteresis work.

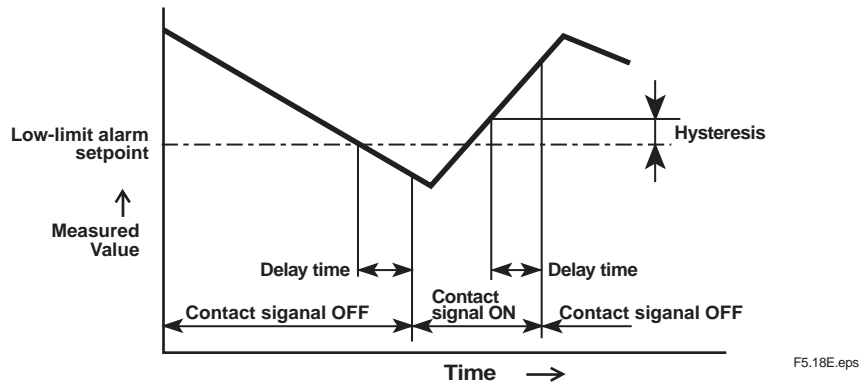

Figure 5.18 Delay Time and Hysteresis for Alarm Contact Output (example of low-limit alarm)

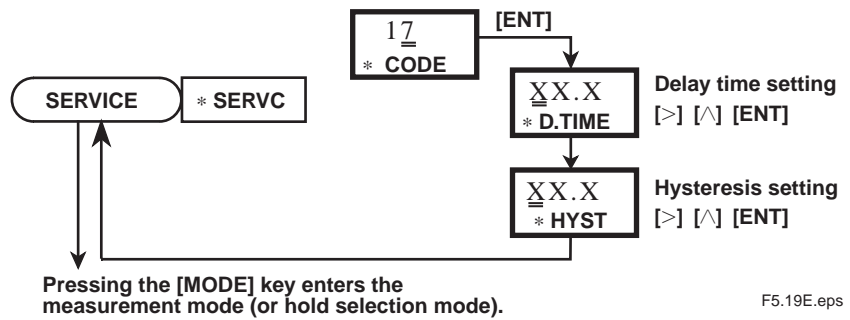

Figure 5.19 Flow for Operating with the Mode for Setting Delay Time and Hysteresis

(1) Setting of Delay Time (*D.TIME)

(Setting upon shipment: 0.2 second)

If you enter CODE 17 to go into this mode, the message display shows "* D.TIME". The converter then asks you to set the delay time. Using the [>] or the [^] key, show the value being set in the data display, and then press the [ENT] key to enter it. Entering a value exceeding the following limits causes a type E19 error to occur.

Setting range: 0.1 to 19.9 s

(2) Hysteresis (*HYST) Setting

(Setting upon shipment: 10 mV)

When you enter the delay time, the message display changes to show * *HYST*. Using the [>] or the [^] key, show the value being set in the data display, and then press the [ENT] key to enter it. Entering a value exceeding the following limits causes a type "E19" error to occur.

Setting range: 0 to 1500 mV

CODE 21 Mode for Setting Function to Check Return-to-half-value Time

The converter has a function to check whether the ORP value of a measured solution has returned to the median value between the value immediately before cleaning and the value during cleaning within the allowable time range after automatic cleaning (function to check the return-to-half-value time). Use this function if the ORP value of a cleaning solution largely differs from that of a measure solution (as a rule, if the difference is greater than 10 % of the span). In this mode, select either ON or OFF for this function. If you have selected ON, set the allowable return-to-half-value time. When the function is turned on, a type "E11" error occurs if the ORP value fails to return to the half value within the allowable time range, turning on the "FAIL" contact signal. Error "E11" can be canceled by selecting CODE 25 at the service level.

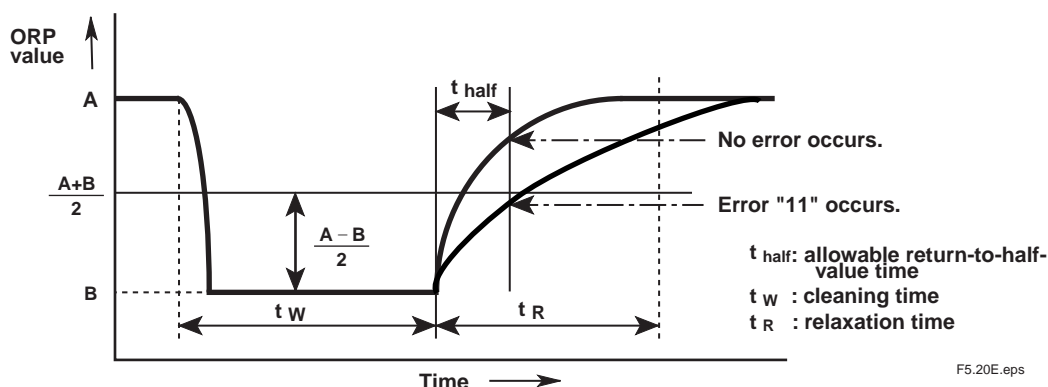

Figure 5.20 Graphical Representation of Function to Check Return-to-half-value Time

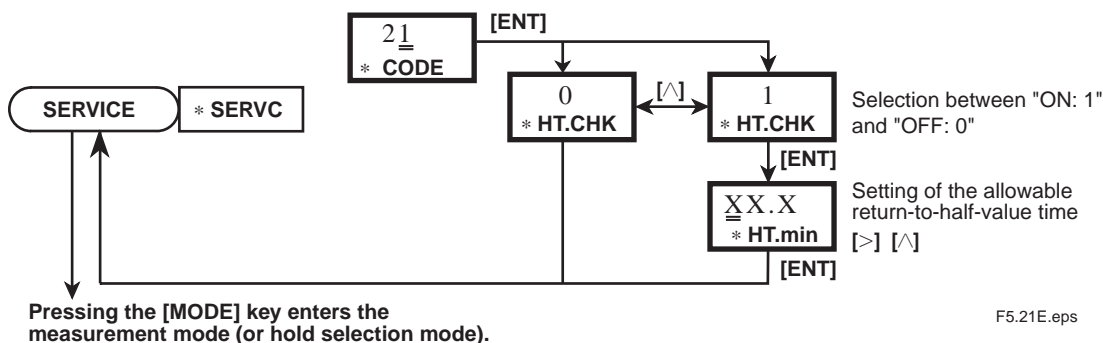

Figure 5.21 Flow for Operating with the Mode for Setting the Function to Check Return-to-half-value Time

(1) Selection of Function to Check the Return-to-half-value Time (*HT.CHK)

(Setting upon shipment: 0: OFF)

If you enter CODE 21 to go to this mode, the message display shows *HT.CHK. The converter then asks you to select either ON or OFF of the function to check the return-to-half-value time. If you want the function turned off, press the [ENT] key with 0 shown on the data display. If you want the function turned on, press the [ENT] key with 1 shown on the data display.

(2) Setting of Allowable Return-to-half-value Time (*HT.min)

(Setting upon shipment : 0.1 minute)

When you select ON, the message display changes to show **HT.min*, asking you to set the allowable return-to-half-value time. Using the [>] or the [Λ] key, show the value being set in the data display, and then press the [ENT] key to enter it. Entering a value exceeding the following limits causes a type "E19" error to occur.

Setting range: 0.1 to 10.0 min



The allowable return-to-half-value time you enter must be shorter than the relaxation time set in the cleaning parameter setting mode at the setting level.

CODE 22 Mode for Setting the Type of Electrode's Reactive Element

(Setting upon shipment: 0: Metal)

Enter the type of the ORP sensor electrode being used. The types allowed to be entered are a precious metal electrode or antimony electrode, If you enter CODE 22 to go into this mode, the message display shows ** Sb.SEN*. The converter then asks you to select the type of electrode. To select a precious metal electrode (platinum or gold), press the [ENT] key with *0* shown on the data display. To select the antimony electrode, press the [ENT] key with *1* shown on the data display.

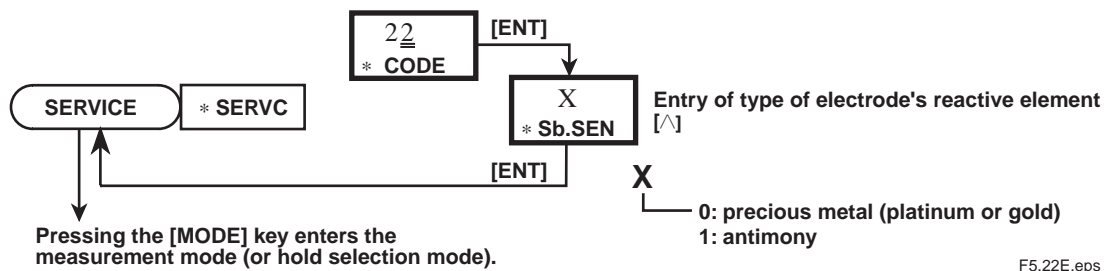

Figure 5.22 Flow for Operating with Mode for Setting Type of Electrode's Reactive Element

6. Electrode Checkup/Calibration Procedure

Electrode checkup and calibration of the ORP Metering System is carried out in the following cases:

[Electrode Checkup]

- When a new ORP sensor is used or after a prolonged shutdown
- When the ORP sensor electrode or wetted part is cleaned

[Calibration]

- When the emf of the sensor exceeds tolerable limits
- When the measured value of the converter needs to be adjusted to that of another instrument

This chapter describes the procedure for calibrating the 4-wire EXA OR series "ORP Metering System," mainly for operation of the OR400G ORP Converter.

6.1 General

6.1.1 Electrode Checkup

Measure a solution with a known oxidation-reduction potential (checkup solution) and check whether the measured value falls within tolerable limits. Check the electrode in the measurement mode. (The electrode can also be checked in the "MAN.CAL" mode at the operation level.)

6.1.2 Manual Calibration

Manual calibration calibrates the OR400G ORP Converter using a solution with a known ORP value so the converter indicates that value. Manual calibration is carried out to adjust the measured value of the OR400G converter to that of another instrument. It is also carried out when, as the result of an electrode checkup, the measured value is slightly off from the tolerable limits. Calibration is performed in the "MAN.CAL" mode at the operation level.

6.1.3 Checkup Solution

To check the electrode, use a solution with a known oxidation-reduction potential. A quinhydrone or ferrous solution can be used as the checkup solution.

6.1.4 Errors Occurring in Calibration

An error occurring in relation to calibration is a type "E2" error (asymmetric potential failure). A type "E2" error occurs if the asymmetric potential exceeds the range from -120 to 120 mV (when the checkup function is turned on).

6.2 Electrode Checkup/Manual Calibration (Emf Correction) Procedure

6.2.1 Preparation

[Cleaning of ORP Sensor]

Move the ORP sensor to a maintenance site and wash off any dirt on the electrode and wetted part with water.

[Preparation of Checkup Solution and Equipment]

The equipment necessary for an electrode checkup are a thermometer, 250 ml wide-mouth beaker (for preparing the checkup solution) and 200 ml beaker. If you have an OR8AX Accessory Tool Kit, use it. Prepare a checkup solution of approximately 100ml. If you do not have a usable checkup solution, make one using a quinhydrone reagent (or a ferrous reagent).



Procedure for Preparing a Checkup Solution (Using Yokogawa-supplied Reagents)

Quinhydrone solution: Pour a packet of the reagent into the 250 ml wide-mouth beaker. Add pure water to dissolve it until you have a solution of 250 ml, If the temperature of the water is too cool, the reagent may not dissolve completely, with some of the reagent floating on the surface. However, this is not a problem in using the solution.

Ferrous solution: Pour one packet each of the light purple and light green reagents in the 250 ml wide-mouth beaker. Add 2 mol/l solution of concentrated sulfuric acid to dissolve the reagent until you have a solution of 250 ml.

Note: When you prepare a solution using concentrated sulfuric acid, first pour approximately 150ml of pure water into the beaker that contains the reagents.

Add 14 ml of concentrated sulfuric acid while stirring the solution. Add more pure water to further dissolve the reagent until you have a solution of 250 ml.

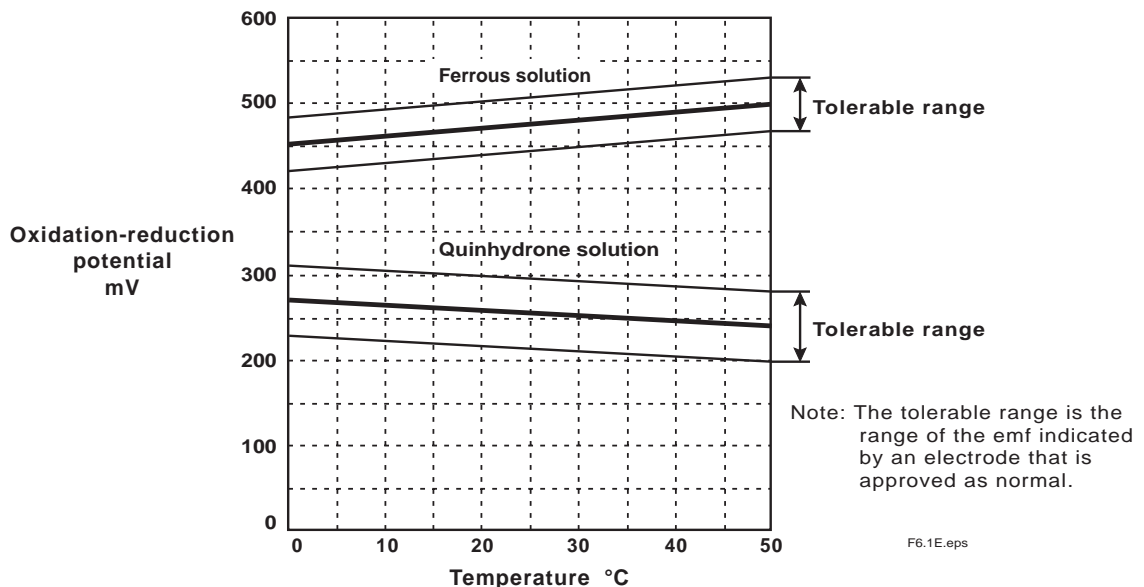

Figure 6.1 Oxidation-reduction Potential Given by Quinhydrone and Ferrous Solutions

6.2.2 Electrode Checkup Operation

An electrode checkup is performed in the measurement mode. (Hold the output signal, if necessary.) This checkup can also be performed in the <MAN.CAL> mode at the operation level. Figure 6.2 shows the flow of operations used to check the electrode at the operation level.

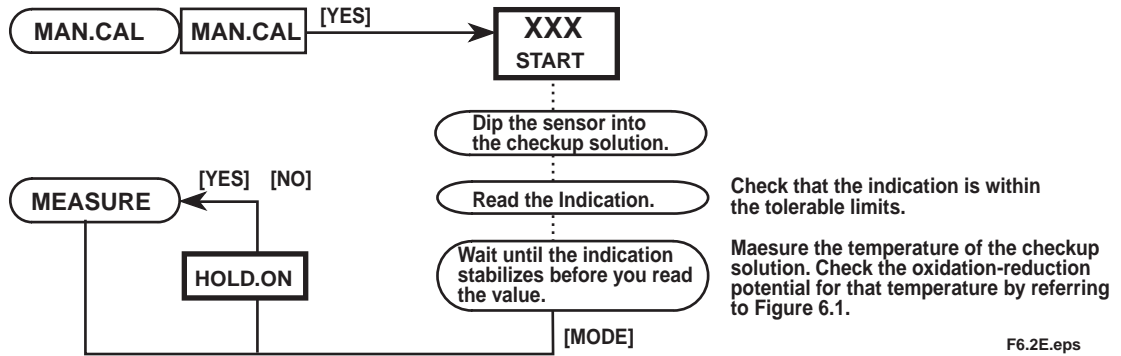

Figure 6.2 Flow of Operations Used to Check Electrode

6.2.3 Manual Calibration (Emf Correction)

Figure 6.3 shows the flow of manual calibration (one-point) performed to correct the emf of the electrode.

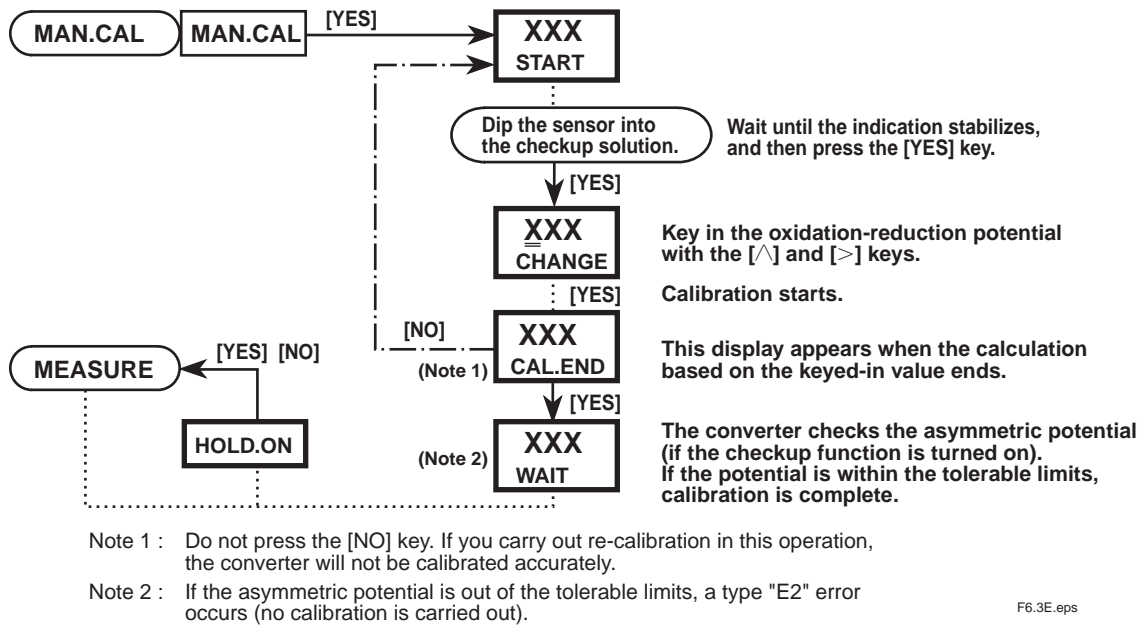

Figure 6.3 Flow of Manual Calibration

Manual calibration for the purpose of correcting the emf can be carried out by dipping the ORP sensor into the checkup solution. If you have an OR8AX Accessory Tool Kit, use the sensor stand that comes with it. Place the stand so it holds the sensor properly, as shown in Figure 6.4.

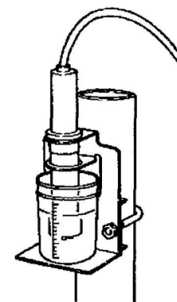

Figure 6.4 Example of How to Hold the Sensor

6.3 Manual Calibration (Tune-in) Procedure

Manual calibration to adjust the reading of the OR400G ORP Converter to that of a reference ORP meter can be carried out by sampling an actual process solution (measured solution). The procedure of this manual calibration is the same as that for correcting the emf discussed in Section 6.2.

6.3.1 Preparation

[Cleaning of ORP Sensor]

- Move the ORP sensor to a maintenance site and wash off any dirt on the electrode and wetted part with water.

[Sampling]

When taking samples, observe the following precautions:

- If it is not possible to compare the measured value of the OR400G ORP Converter with that of a reference ORP meter using the same solution on a real-time basis, exercise care to prevent any variation in the oxidation-reduction potential due to, for example, a change in temperature (avoid such variations by taking samples just before you start calibration or by taking a relatively large sample).



Tip

If it is not possible to compare ORP values of the same sample on a real time basis, it is advisable that you use a portable ORP meter calibrated with the value given by the reference ORP meter (PH72) and then adjust the OR400G Converter to indicate that value.

- Take a sample that shows an oxidation-Reduction potential with as much deviation from 0 mV as possible but still within the measuring range.

6.3.2 Manual Calibration (Tune-in)

Figure 6.5 shows the flow of operations used in manual calibration.

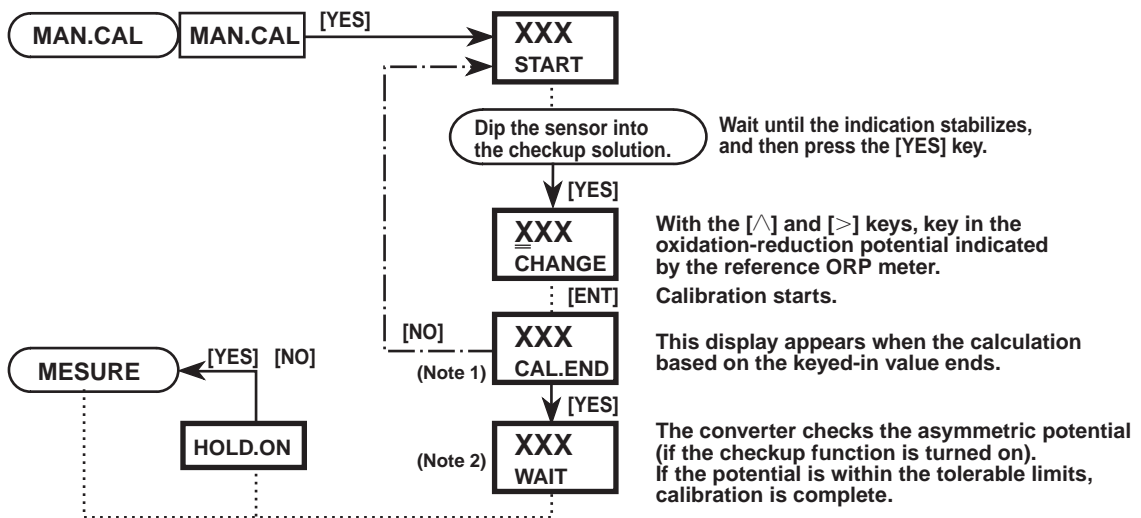

Note 1 : Do not press the [NO] key. If you carry out re-calibration in this operation, the converter will not be calibrated accurately.

Note 2 : If the asymmetric potential is out of the tolerable limits, a type "E2" error occurs (no calibration is carried out).

F6.5E.eps

Figure 6.5 Flow of Manual Calibration

7. Inspection and Maintenance

It is important for maintaining the accuracy of the EXA OR series of the 4-wire ORP Metering System to perform inspection and maintenance at fixed intervals. It also serves to prevent problems from arising. This chapter describes daily inspection and maintenance for the purpose of maintaining system performance.

7.1 Regarding Overall 4-wire ORP Metering System

Tables 7.1 and 7.2 summarize the inspection and maintenance items for equipment composing the 4-wire ORP Metering System. The procedure for inspection and maintenance of the ORP converter is described in Section 7.2. For inspection and maintenance of the sensors and holders, see their respective separate instruction manuals.

7.1.1 Inspection and Maintenance to be Implemented Periodically

Table 7.1 summarizes the items which are recommended to be inspected and maintained periodically.

Table 7.1 Items for Periodic Inspection and Maintenance of 4-wire ORP Metering System

Instrument or Apparatus	Item	Recommended Interval
All equipment	a. Electrode checkup	a. 1 to 3 months
ORP sensor	a. Cleaning of reactive element and junction b. Replenishment of KCl solution (in the case of an OR8EFG Sensor)	a. 1 to 3 months b. 1 to 3 months
ORP converter	a. Check of degree of dryness within the converter b. Replacement of fuse	a. 6 months b. 1 to 2 years
Submersible and flow-through holders	a. Inspection of O-ring at sensor hold b. Cleaning of cleaner nozzle (in the case of a jet-water cleaner) c. Inspection for leakage from the solenoid valve for cleaning utility d. Inspection for corrosion in ultrasonic cleaner	a. 6 months b. 1 to 2 months c. 6 months d. 6 months

T7.1E.eps

7.1.2 Inspection and Maintenance to be Implemented on Occasion

Carry out the maintenance that is not directly related to measurement functions and maintenance associated with errors at any required time.

Table 7.2 Items for Occasional Inspection and Maintenance of 4-wire ORP Metering System

Faulty Phenomenon	Content of Inspection
"E2" Error	Check whether the reactive element or the wetted part of the ORP sensor is contaminated. Check whether the cleaner nozzle is clogged (in the case of a jet-water cleaner).
"E9" Error	Check whether the reactive element or the wetted part of the ORP sensor is contaminated. Check whether there is any deteriorated insulation or break in the sensor cable.
Reduced visibility of the inside of the converter through the window	Wipe off the dirt on the transparent window using a tissue or the like. (Use detergent for hard-to-clean dirt.)

T7.2E.eps

7.2 Inspection and Maintenance Procedure for OR400G ORP Converter

7.2.1 Wiping off Front Cover (Window)



Do not wipe organic solvents on the window. Otherwise, this may cause blurring or cracks.

Wipe off any dirt on the window (material: weather-resistant polycarbonate resin) on the front cover with a tissue or soft cloth dampened in water. If the dirt is difficult to remove, wipe it off using detergent.

7.2.2 Inspection of Degree of Dryness Within the Converter

Check that the converter does not have condensation on the inside of the front cover window. High humidity adversely affects electrical components. In addition, degraded insulation of the wiring terminals may lead to a failure to obtain correct measurements.

7.2.3 Replacement of Fuse

It is recommended that the fuse in the converter be replaced every one to two years.



Be sure to turn off the power before you attempt to replace the fuse.

The fuse is located on the printed circuit board deep inside the case (see Figure 7.1). Rotate the fuse holder cap (the fuse is attached) counterclockwise and pull it forward to remove it. Use a fuse with a rating meeting the specification.

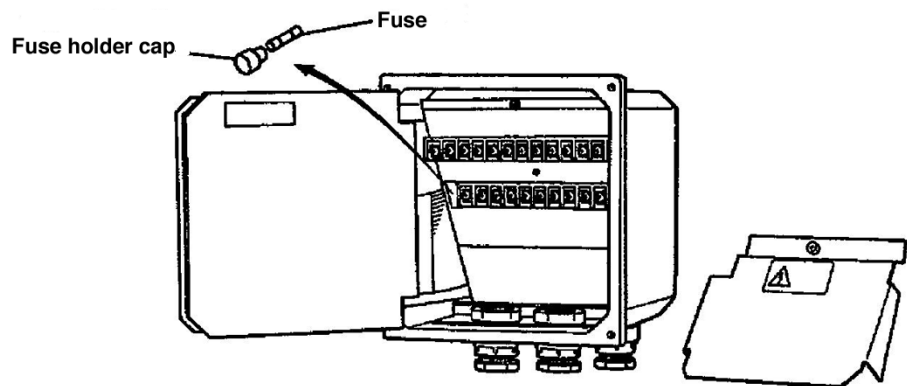

Figure 7.1 Fuse of Converter

8. Troubleshooting

This chapter describes the countermeasures for failures classifying the cases into three categories: OR400G ORP Converter failure, detection of failure with the selfdiagnosis function, and abnormal measurements.

The causes for abnormal measurements are not always limited to equipment failures. If an abnormal phenomenon occurs, first check whether:

- The property of the measured solution is different from normal.
- The ORP sensor is installed properly.

8.1 Corrective Actions in Case of a Converter Malfunction

8.1.1 Case Where ORP Converter Fails to Function

If the converter does not operate even when the power is turned on, one cause may be a blown fuse inside the converter. First turn off the power and examine the fuse (see Subsection 7.2.3 on page 7-2). If the fuse is blown, replace it with a new one. If fuses frequently blow and the cause is not clear, request an inspection by Yokogawa. If the fuse is normal, examine the wired cables.

8.1.2 Case Where Problems are Found with Operation Keys or Displays

If the operation keys do not operate smoothly or the display fails (e.g., a character segment does not light up), the printed circuit board (digital board) must be repaired (or replaced with a new one). After the printed circuit board has been replaced, operation checks and parameter settings are necessary. Contact Yokogawa and request board-replacement work.

If you want to check the software version, select CODE 23 at the service level.

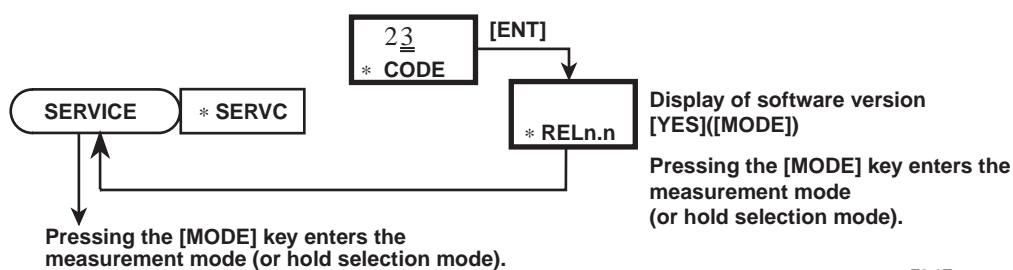

F8.1E.eps

Figure 8.1 Operation to Show Software Version

8.2 Corrective Actions in Case of Failure (Error) Detection

If a failure is detected through a selfdiagnosis of the OR400G ORP Converter, the FAIL contact signal turns on. Also, the [FAIL] lamp on the operation panel lights up and an error number appears in the message display. However, in the case of type "E2", "E17" and "E19" errors, neither the <FAIL> lamp nor the FAIL output signal turns on, except that an error number appears in the message display.



Tip

If an error is detected during key operation or while a certain action is in progress, the FAIL contact signal turns on immediately, though the error number is displayed only after that key operation or action is complete.

If a FAIL contact signal has turned on, take measures according to Table 8.1.

Table 8.1 Corrective Actions in Case of Failure (Error) Detection

Error No.	Relevant Mode	Description of Errors and Their Causes	Corrective Actions
E2	MAN.CAL mode	Asymmetric-potential failure Occurs if the asymmetric potential exceeds the range from -120 to 120mV (detected when the asymmetric potential checkup function is turned on). <ul style="list-style-type: none"> ● The keyed-in ORP value is incorrect. ● The reactive element or junction of the sensor is contaminated. ● The ORP sensor has deteriorated (reached the end of its service life). 	Eliminate the causes and check the electrode. If the failure is not corrected, replace the ORP sensor.
E9	Measurement mode	Setpoint failure Occurs if the measured value exceeds the range from -1500 to 1500 mV. <ul style="list-style-type: none"> ● There is a problem with the sensor cable such as a break. ● There is a problem with the junction of the sensor (contaminated with dirt, reversed flow of measured solution, etc.) 	Clean the reactive element of the sensor and perform an electrode checkup. If the error is detected again, examine the wired cables.
E10	All modes	Unsuccessful writing to EEPROM	First turn off the power to check whether the problem is corrected. If the error is detected once again, request repair by Yokogawa.
E11	Measurement mode (during automatic cleaning)	Time error in return to half value Occurs if the ORP value fails to return to its half value within the preset time range (detected when the function to check the return-to-half-value time is set to ON). <ul style="list-style-type: none"> ● The difference between the ORP value of the measured solution and that of the cleaning solution is very marginal. ● The reactive element or wetted part of the sensor is contaminated. 	Check the electrode to ensure that the sensor is normal. Then check the allowable return-to-half-value time set in CODE 21.
E17	RANGE (measurement range setting) mode	Incorrect span A value that causes the span to fall below 100mV was set in the measurement range setting mode.	Change the maximum or minimum value of the range so the span becomes greater than the tolerable limit.
E19	During data entry	Setpoint failure A value exceeding the tolerable limits was entered.	Reenter the value within the tolerable limits.
E20	All modes	Instrument initialization failure A failure occurred in the basic data values of the instrument.	The converter needs to be repaired. Request service from Yokogawa.

T8.1E.eps

8.3 Corrective Actions in the Case of a Measurement Failure

If any failure occurs with a measurement that may interfere with normal system operation, take corrective actions according to Table 8.2. Note that the causes of most abnormal measurements trace back to the ORP sensor. There are varying types of sensors with different structures that are used with the 4-wire ORP Metering System. Consequently, depending on the type of sensor, different corrective actions are taken against a failure. For further details, see the separate instruction manual for the type of ORP sensor you use.

Table 8.2 Corrective Actions in the Case of a Measurement Failure

Phenomenon	Cause	Measures
The actual measurement is stable but the converter shows an unstable measurement.	<ol style="list-style-type: none"> 1. The junction is dirty. The measured solution flows in the reverse direction from the junction. 2. There is deterioration in the insulation around the sensor cable (measurement circuit). 3. The supply voltage varies in excess of the tolerable limits. 4. The ORP sensor has reached the end of its service life. 	<ol style="list-style-type: none"> 1. Clean the junction. Check the pressure of the measured solution if a sensor feeding a KCl solution is used. 2. Restore the insulation's quality to $10^8 \Omega$ or more. 3. Improve the situation. 4. Use a new ORP sensor.
The converter shows a large error.	<ol style="list-style-type: none"> 1. Calibration failure 2. The reactive element is dirty. 3. Sensor degradation 	<ol style="list-style-type: none"> 1. Re-calibrate the sensor. 2. Clean the element. 3. Use a new ORP sensor.
The converter shows an abnormal measurement	<ol style="list-style-type: none"> 1. The ORP sensor has reached the end of its service life. 2. Poor insulation in wiring cables or connections 3. Break in sensor cable 	<ol style="list-style-type: none"> 1. Use a new ORP sensor. 2. Restore the insulation's quality between the cable connections and terminals to $10^8 \Omega$ or more. 3. Replace the ORP sensor
The converter is slow to respond.	<ol style="list-style-type: none"> 1. Solution stagnates at the measuring point. 2. Dirt has accumulated on the sensor's reactive element or the junction is clogged. 	<ol style="list-style-type: none"> 1. Correct the condition. 2. Clean the element. If the problem persists, replace the electrode.
Measurement presents hunting.	<ol style="list-style-type: none"> 1. The cleaning utility is leaking. 2. The converter picks up external noise. 3. There is a poor contact in the wiring around the sensor cable (measurement circuit). 	<ol style="list-style-type: none"> 1. Correct the condition (e.g., replace the solenoid valve). 2. Locate the noise source and take proper measures. 3. Repair the defective portion of the wiring cables.

T8.2E.eps

Worksheet for Operation Parameter Setting

Service level

	Mode/Setting Item	Display	Default
CODE03	Mode for setting asymmetric potential check function		(See page 5-14)			
	Selection between "ON/OFF"	* CHECK	1 : ON	<input type="checkbox"/> 0, <input type="checkbox"/> 1	<input type="checkbox"/> 0, <input type="checkbox"/> 1	<input type="checkbox"/> 0, <input type="checkbox"/> 1
CODE05	"Burn-up/down" function setting mode		(See page 5-14)			
	Selection of the function	* BURN	0 : OFF	<input type="checkbox"/> 0, <input type="checkbox"/> 1, <input type="checkbox"/> 2	<input type="checkbox"/> 0, <input type="checkbox"/> 1, <input type="checkbox"/> 2	<input type="checkbox"/> 0, <input type="checkbox"/> 1, <input type="checkbox"/> 2
CODE07	Mode for setting automatic return to measurement mode		(See page 5-15)			
	Selection between "ON/OFF"	* RET.	1 : ON	<input type="checkbox"/> 0, <input type="checkbox"/> 1	<input type="checkbox"/> 0, <input type="checkbox"/> 1	<input type="checkbox"/> 0, <input type="checkbox"/> 1
CODE12	Mode for setting output signal transmission		(See page 5-15)			
	Selection between "ON/OFF"	*mA.COD	1 : ON	<input type="checkbox"/> 0, <input type="checkbox"/> 1	<input type="checkbox"/> 0, <input type="checkbox"/> 1	<input type="checkbox"/> 0, <input type="checkbox"/> 1
CODE14	Mode for setting the function of contact output S1		(See page 5-16)			
	Selection of function/ type of output	*S1	0.0 (OFF)	[], 0	[], 0	[], 0
CODE15	Mode for setting the function of contact output S2		(See page 5-17)			
	Selection of function/ type of output	*S2	0.0 (OFF)	[], 0	[], 0	[], 0
CODE16	Mode for setting the function of contact output S3		(See page 5-17)			
	Selection of function/ type of output	*S3	0.0 (OFF)	[], 0	[], 0	[], 0
CODE17	Mode for setting delay time and hysteresis of alarm contact output		(See page 5-18)			
	Delay time setting	*D.TIME	0.2 [s]	[]	[]	[]
	Hysteresis setting	*HYST	10 [mV]	[]	[]	[]
CODE21	Mode for setting function to check return-to-half-value time		(See page 5-19)			
	Selection between "ON/OFF"	* HT.CHK	0 : OFF	<input type="checkbox"/> 0, <input type="checkbox"/> 1	<input type="checkbox"/> 0, <input type="checkbox"/> 1	<input type="checkbox"/> 0, <input type="checkbox"/> 1
	Setting of allowable return-to-half-value time	* HT.min	0.1 [min]	[]	[]	[]
CODE22	Mode for setting type of electrode's reactive element		(See page 5-20)			
	Setting of reactive element	* Sb.SEN	0: precious metal	<input type="checkbox"/> 0, <input type="checkbox"/> 1	<input type="checkbox"/> 0, <input type="checkbox"/> 1	<input type="checkbox"/> 0, <input type="checkbox"/> 1

SerPara-E.eps

Setting level

Mode/Setting Item	Display	Default	.	.	.
SETPOINTS Alarm point setting mode	* SETP	(See page 5-8)			
Alarm point setting of contact output S1	*SETP.1	500 [mV]	[]	[]	[]
Alarm point setting of contact output S2	*SETP.2	-500 [mV]	[]	[]	[]
High/low-limit alarm point setting of contact output S3	*SETP.3	250 [mV]	[]	[]	[]
Low-low-limit alarm point setting of contact output S3	*S3.LOW	-1000 [mV]	[]	[]	[]
High-high-limit alarm point setting of contact output S3	*S3.HIGH	1000 [mV]	[]	[]	[]
RANGE Measuring range setting mode	*OUTPU	(See page 5-9)			
Minimum value setting in the measuring range	*4mA	-1500[mV]	[]	[]	[]
Maximum value setting in the measuring range	*20mA	1500[mV]	[]	[]	[]
SET HOLD Hold parameter setting mode	*SET.HD	(See page 5-10)			
Selection of "ON/OFF" of hold	*HLD.OF *HLD.ON	"OFF"	<input type="checkbox"/> OFF <input type="checkbox"/> ON	<input type="checkbox"/> OFF <input type="checkbox"/> ON	<input type="checkbox"/> OFF <input type="checkbox"/> ON
Selection of the value immediately before holding or the fixed value	*HLD.LST	("Value immediately before holding")	<input type="checkbox"/> Value immediately before holding	<input type="checkbox"/> Value immediately before holding	<input type="checkbox"/> Value immediately before holding
Current-signal level of the fixed value	*HD.FIX *HLD.mA	(12.0 [mV])	<input type="checkbox"/> Fixed value []	<input type="checkbox"/> Fixed value []	<input type="checkbox"/> Fixed value []
WASH Cleaning parameter setting mode	*WASH	(See page 5-11)			
Selection between "ON/OFF" of cleaning timer	*T.OFF *T.ON	"OFF"	<input type="checkbox"/> OFF <input type="checkbox"/> ON	<input type="checkbox"/> OFF <input type="checkbox"/> ON	<input type="checkbox"/> OFF <input type="checkbox"/> ON
Cleaning period	*INT.H	(10.0[h])	[]	[]	[]
Cleaning time	*WT.min	(0.1[min])	[]	[]	[]
Relaxation time	*RT.min	(0.2[min])	[]	[]	[]

SetPara-E.eps

Customer Maintenance Parts List

Model OR400G 4-Wire ORP Metering System ORP Converter

EXA OR

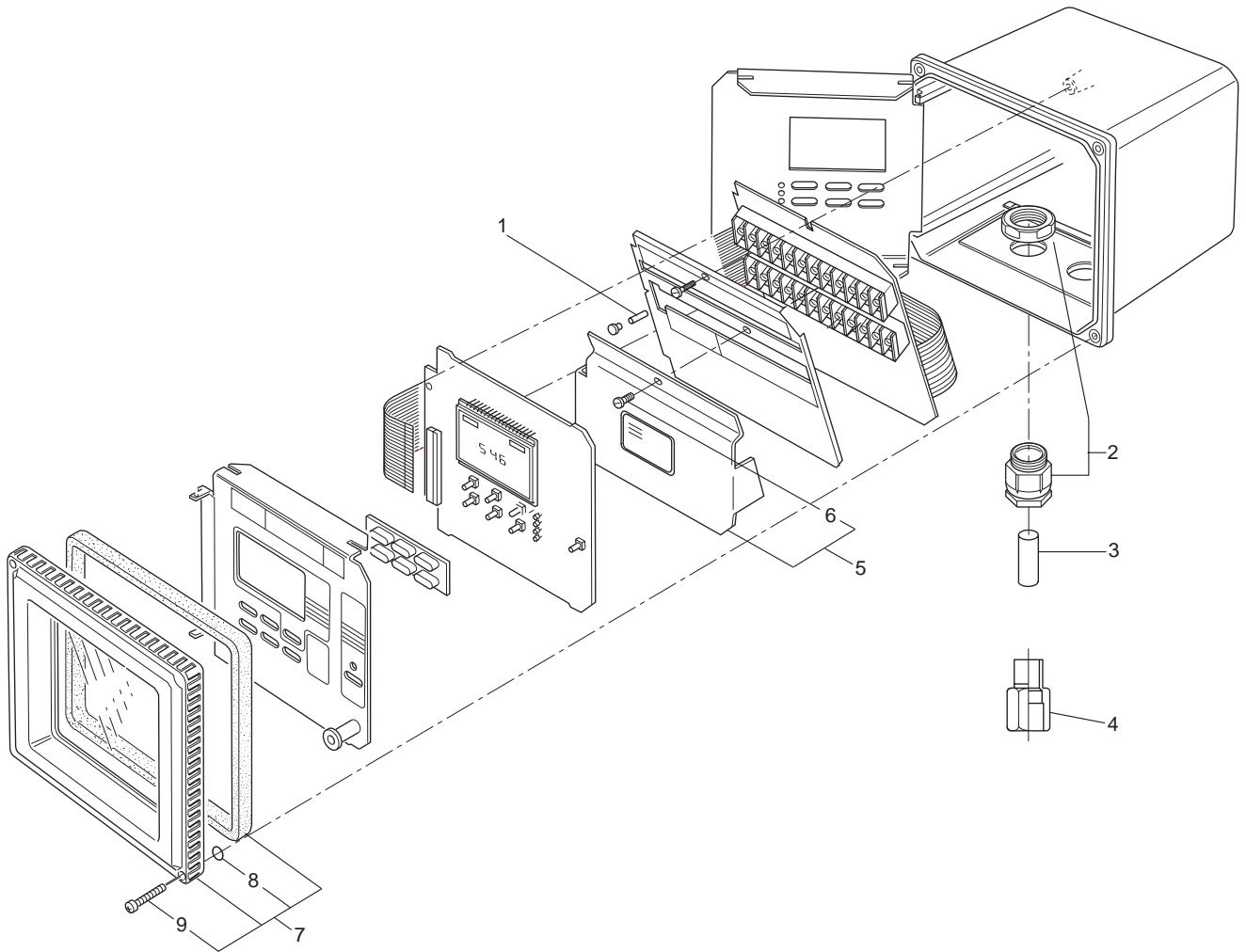

Item	Part No.	Qty	Description
1	K9313PS	1	Fuse (Time Lag Fuse)
2	B1002JZ	4	Cable Gland
3	K9334CN	3	Insert
4	K9141TX	4	Fitting (for Option Code: /AFTG)
	K9311KQ	4	Adapter (for Option Code: /ANSI)
5	—	1	Terminal Cover
6	—	1	Screw
7	K9313DW	1	Cover Assembly
8	K9221US	4	O-Ring
9	Y9420LU	4	Screw

Option Code: / U
Pipe / Wool Mounting Hardware

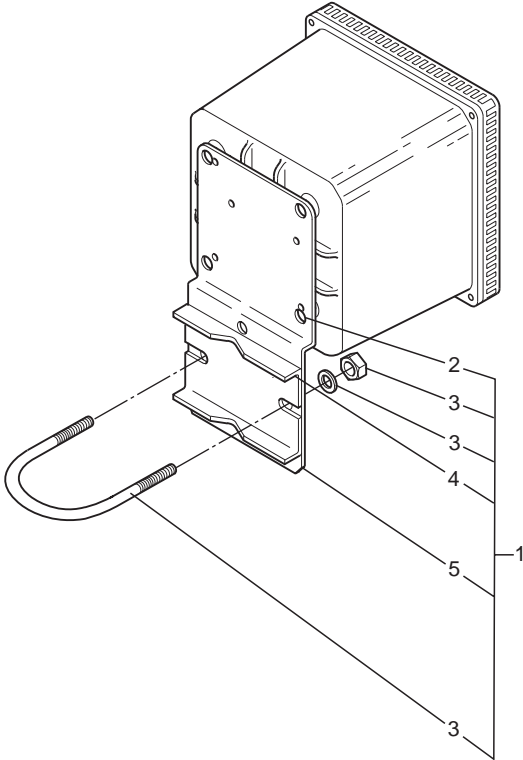

Option Code: / PM
Panel / Mounting Hardware

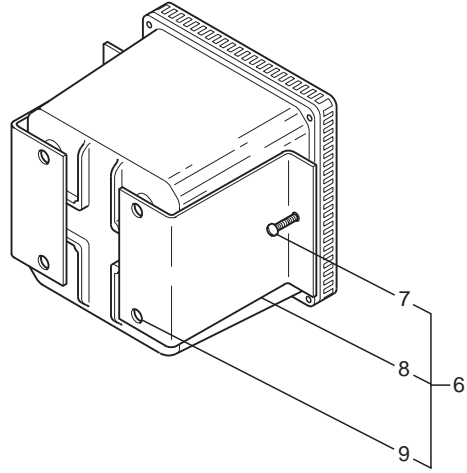

Item	Part No.	Qty	Description
1	K9171SS	1	Mounting Set
2	Y9608KU	4	Screw
3	D0117XL-A	1	U-Bolt Assembly
4	K9171SY	1	Plate
5	K9171SX	1	Bracket
6	K9171ST	1	Mounting Set
7	Y9520LU	2	Screw
8	K9171SW	2	Bracket
9	Y9608KU	4	Screw

Revision Record

Manual Title : 4-wire ORP metering System Model OR400G ORP converter

Manual Number : IM 12C4C1-01E

Edition	Date	Remark (s)
1st	Oct. 1995	Newly published
2nd	Nov. 2006	IM Style & Format is renewed. Revised and Corrected all over. ("After sales warranty" added, etc.)
3rd	Aug. 2007	p.ii, Revisions of IM No. to be refered; p.2-5, Additions of option code /H3 and /H4 for awning hood, deletion of /H, and revisions of accessories; p.2-6, Revisions of OR400G external dimensions for /H3 and /H4 awning hood

Thank you for selecting our Model OR400G ORP Converter.

The Instruction Manual IM 12C4C1-01E 3rd edition supplied with this product has been amended as follows, please make a note in your copy.

On p.2-5, Additions of option code /SPS for teflon coated SUS screws, and accessories.

Some revision of CMPL 12C04C01-01E 2nd edition.

Items detected by self-diagnostics:

ORP measurement value abnormal

Zero point shift abnormal

Settling time abnormal

EEPROM abnormal

2.2.2 Model and Codes

Model	Suffix Code	Option Code	Specifications
OR400G	4-wire ORP Converter
Power supply voltage	-1	100/110 V AC, 50/60 Hz
	-2	200/220 V AC, 50/60 Hz
Language for warning, etc.	-J	Japanese
	-E	English
	-A	Always -A
Option	Mounting hardware	/U	Pipe mounting bracket
		/PM	Panel mounting bracket
	Hood	/H3	Awning hood (carbon steel)
		/H4	Awning hood (stainlss steel)
		/X1	Epoxy-baked finish
	Tag plate	/SCT	With stainless tag plate
	Conduit Adapter	/AFTB	G1/2
		/ANSI	1/2NPT
		/SPS	Teflon coated SUS steel screws

T14.EPS

Accessories

Item	Part Number	Remarks
Label for contact signals	K9313PC	For display on the operation panel
Spare fuse	K9313PS	0.1 A (for either a 100V or 200V power line)
Pipe/wall mounting bracket	K9171SS	Attached when option code "/U" is specified
Panel mounting bracket	K9171ST	Attached when option code "/PM" is specified
Shading hood	K9664CA	Attached when option code "/H3" is specified
Shading hood	K9664CC	Attached when option code "/H4" is specified
Tag plate	Y9412NP	Attached when option code "/SCT" is specified
Conduit adppter	Y9313PN	Attached when option code "/AFTG" is specified
Conduit adppter	Y9313PW	Attached when option code "/ANSI" is specified

T2.5E.eps

Customer Maintenance Parts List

Model OR400G 4-Wire ORP Metering System ORP Converter

EXA OR

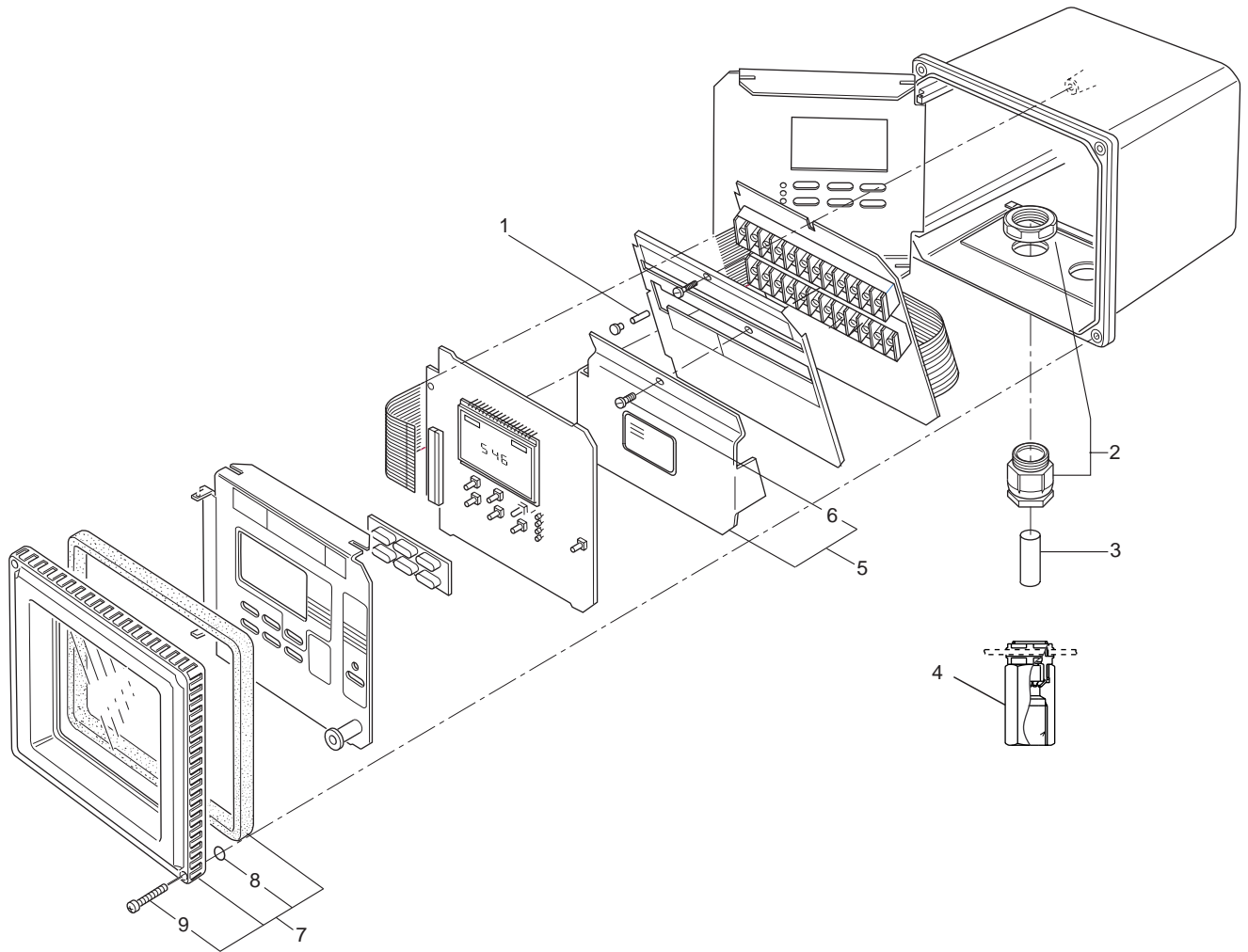

Item	Part No.	Qty	Description
1	K9313PS	1	Fuse (Time Lag Fuse)
2	B1002JZ	4	Cable Gland
3	K9334CN	3	Insert
4	K9141TX	4	Fitting (for Option Code: /AFTG)
4	K9311KQ	4	Adapter (for Option Code: /ANSI)
5	—	1	Terminal Cover
6	—	1	Screw
7	K9313DW	1	Cover Assembly
8	Y9101XA	4	O-Ring
9	Y9420LU	4	Screw

Pipe/Wall Mounting Hardware
(Option Code : /U)

Panel Mounting Hardware
(Option Code : /PM)

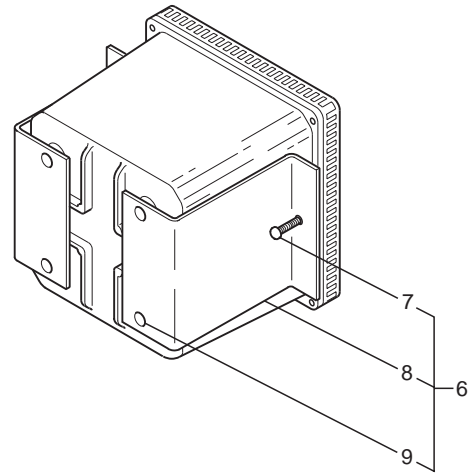
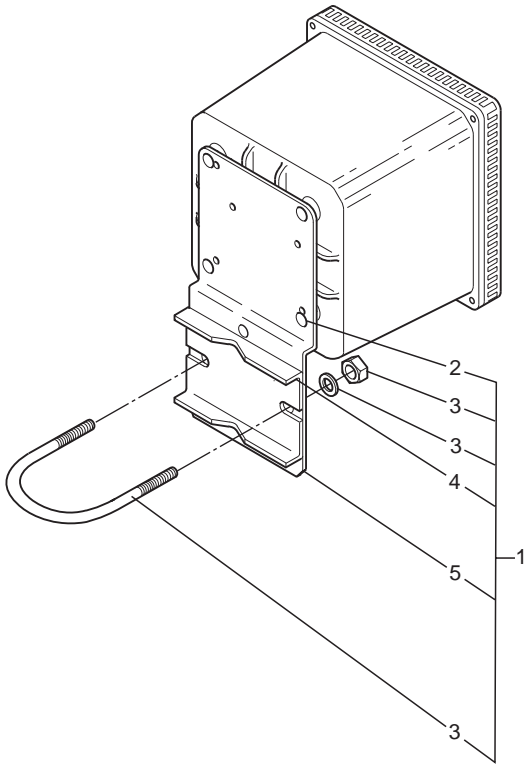

Sun Protection Cover
(Option Code: /H3, /H4)

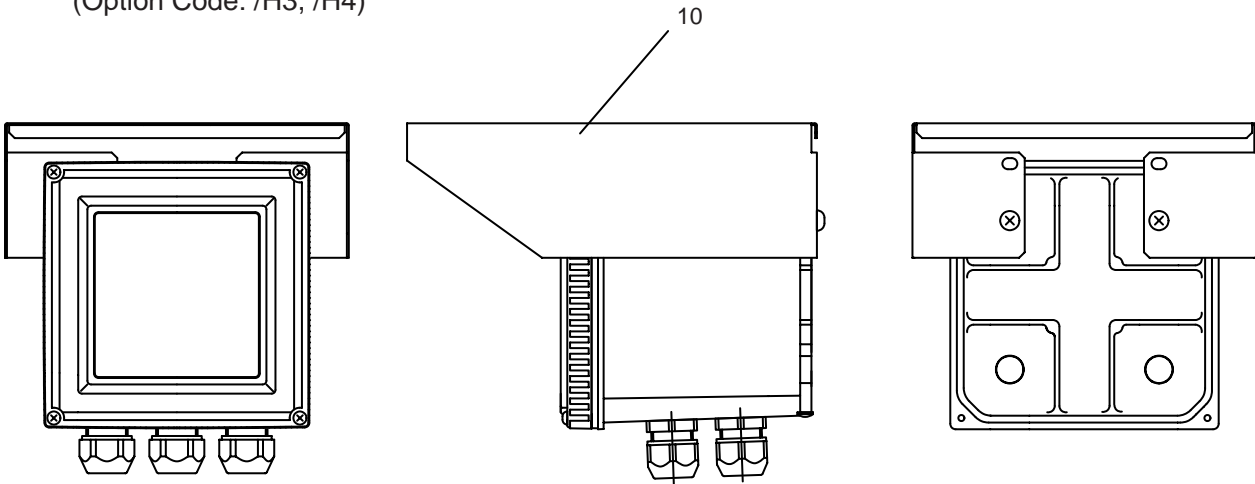

Item	Part No.	Qty	Description
1	K9171SS	1	Mounting Set (/U)
2	Y9608KU	4	Screw
3	D0117XL-A	1	U-Bolt Assembly
4	K9171SY	1	Plate
5	K9171SX	1	Bracket
6	K9171ST	1	Mounting Set (/PM)
7	Y9520LU	2	Screw
8	K9171SW	2	Bracket
9	Y9608KU	4	Screw
10	—		Sun Protection Cover
	K9664CA	1	Carbon steel (/H3)
	K9664CC	1	Stainless steel (/H4)