

# Drawings

## Model PH10HLD Immersion Holder

Unit : mm

□ PH10HLD-AA-□□-HST-PE

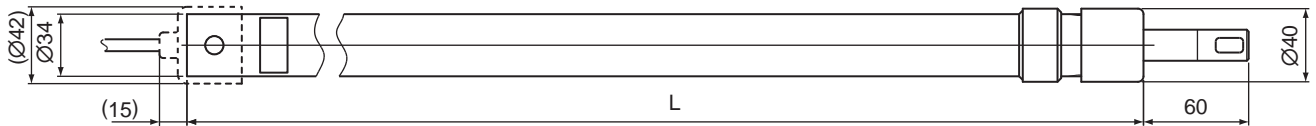

□ PH10HLD-AA-□□-HSS-PE

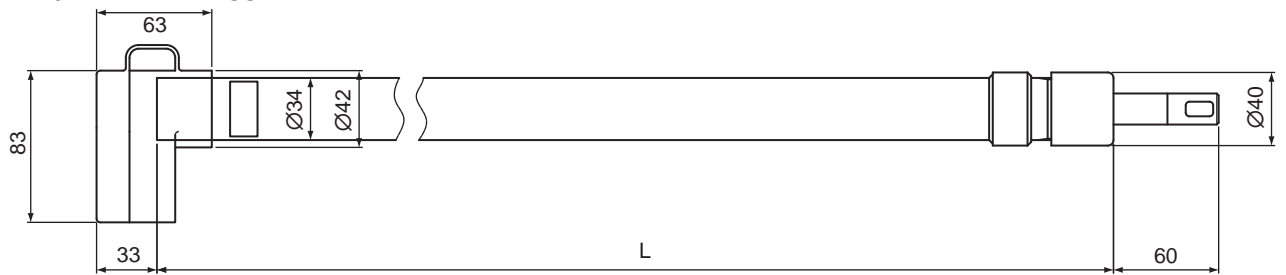

Model and Code	L(Holder length)	Weight (kg)
PH10HLD-AA-10-□□□-PE	1000 mm	Approx. 0.4
PH10HLD-AA-20-□□□-PE	2000 mm	Approx. 0.8

Unless otherwise specified, differences in the dimensions are specified as : General tolerance=(Criteria of tolerance class IT18 in JIS B0401-1986)/2.

□ Mounting Hardware for Holders (Weight: Approx. 1 kg)

/MS1: 1 set

/MS2: 2 sets

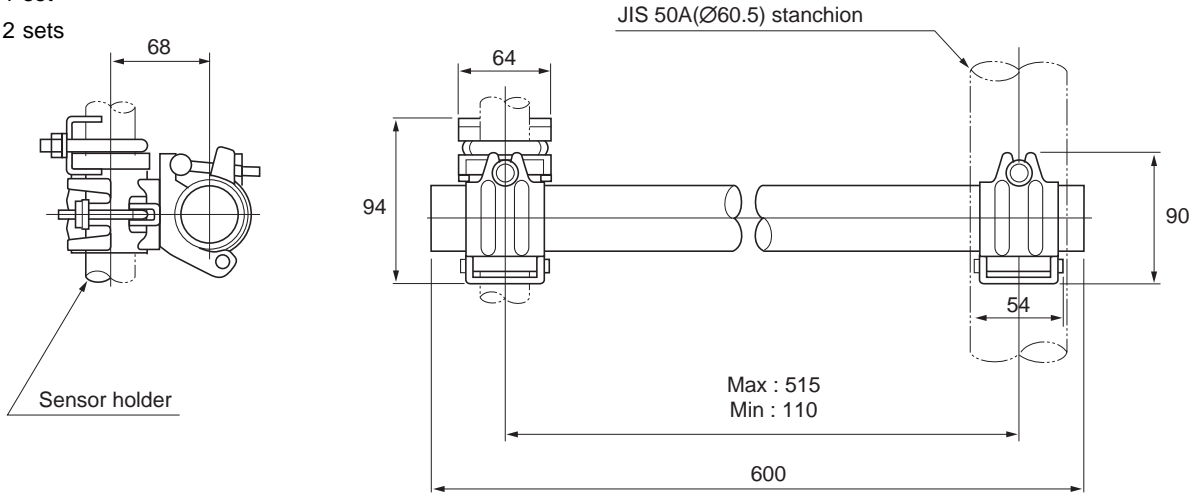

□ Calibration Holder Fixing Hardware for Holders (Weight: Approx. 2.5 kg)

/CALK

F012.EPS

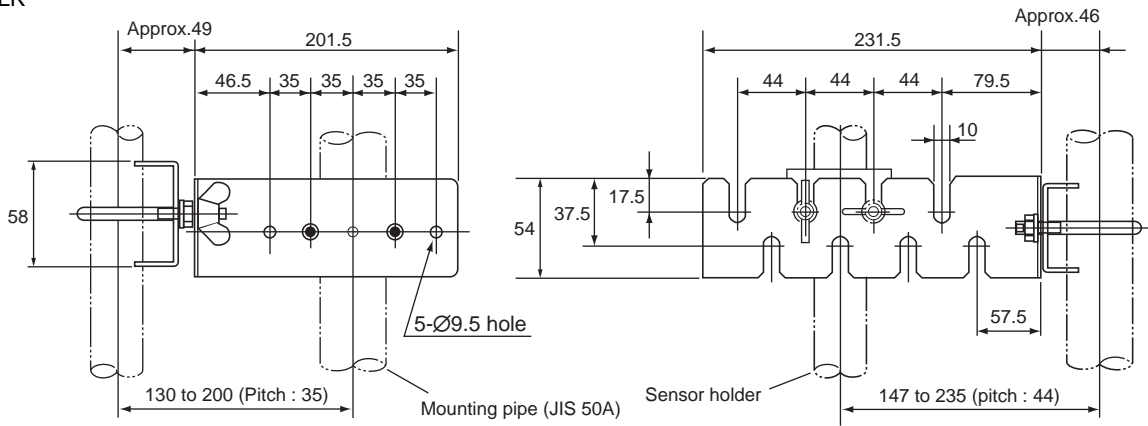

F013.eps

Unless otherwise specified, differences in the dimensions are specified as : General tolerance=(Criteria of tolerance class IT18 in JIS B0401-1986)/2.