

Drawings

IR810G Wall & Panel Type Infrared Gas Analyzer

SD 11G06C01-01EN

Unit: mm

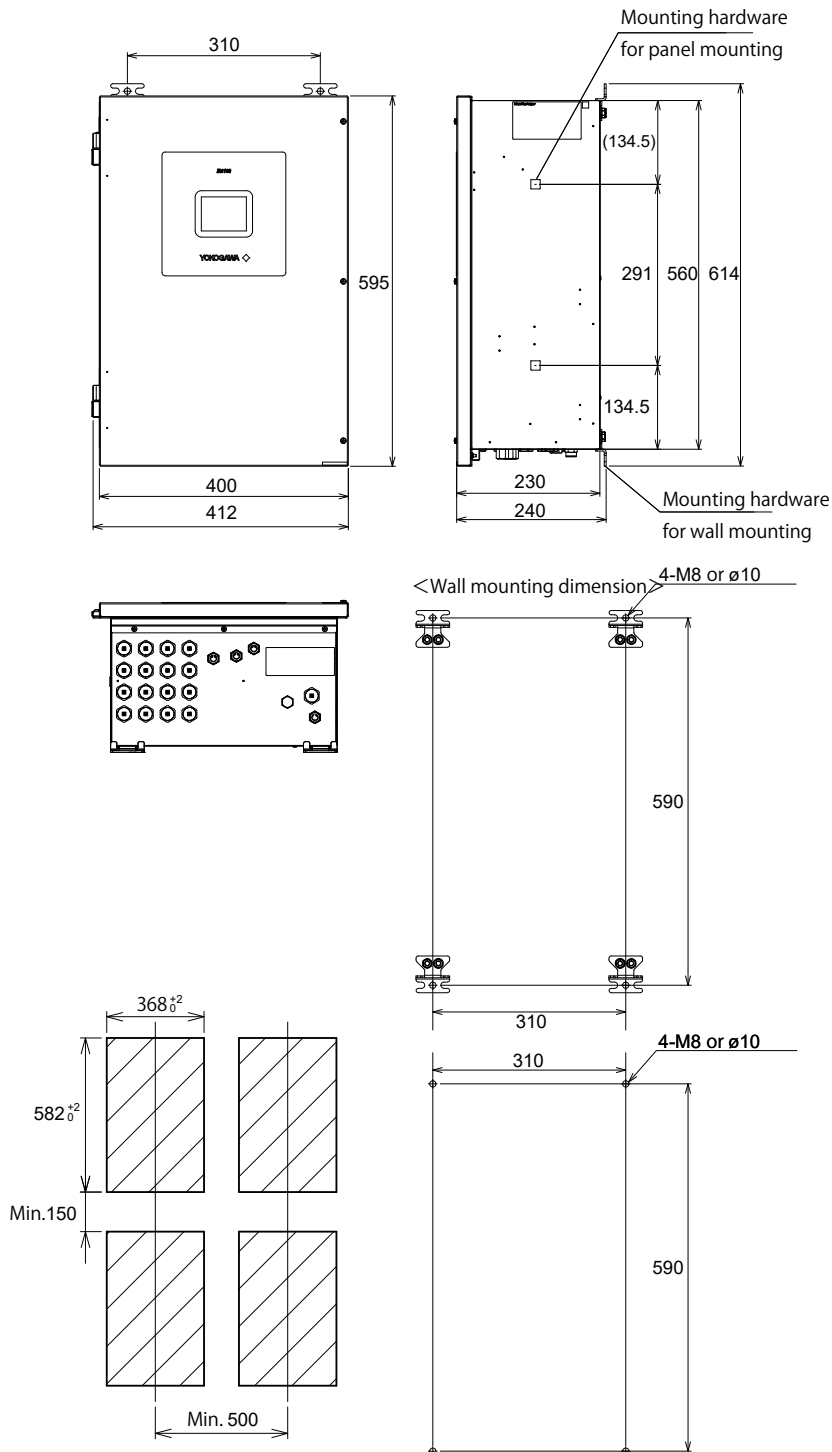

Wight: approx. 17 kg

Unless otherwise specified, differences in the dimensions are specified as: General tolerance = \pm (Criteria of tolerance class IT18 in JIS B0401-1998)/2.

□ /RP

Unit: mm

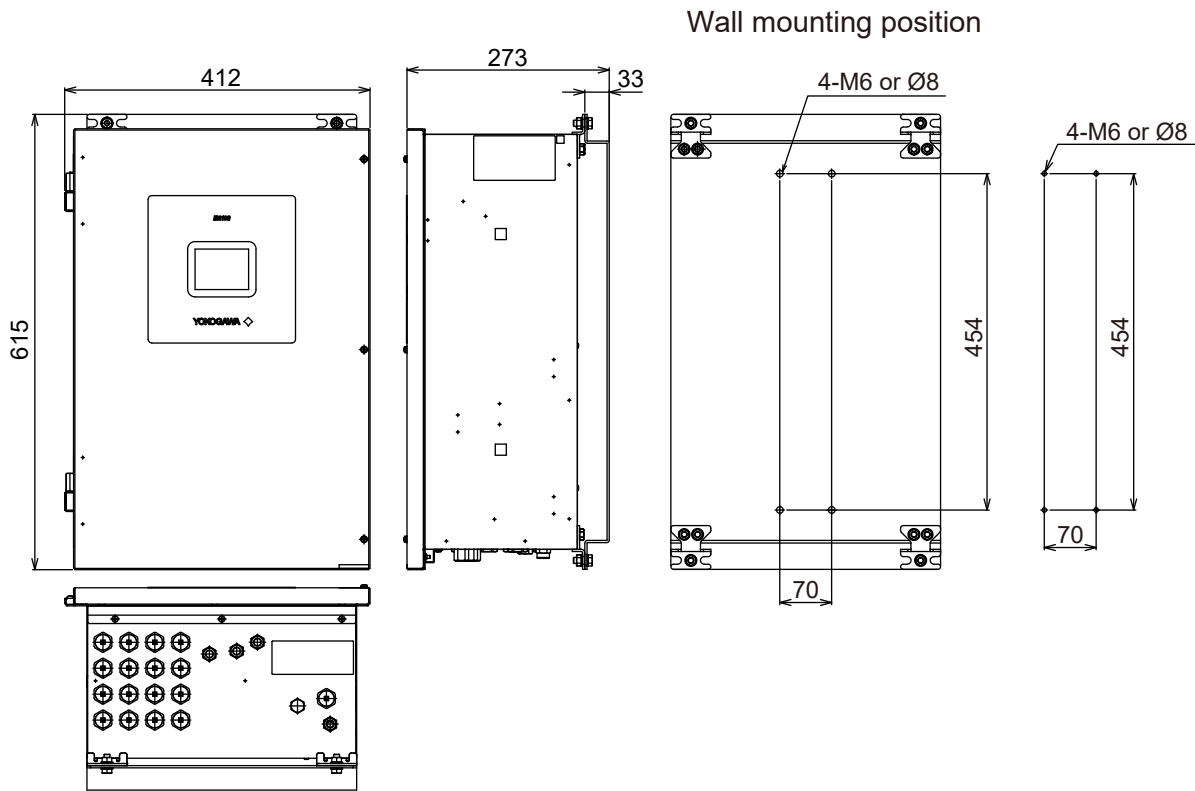

<Maintenance space>

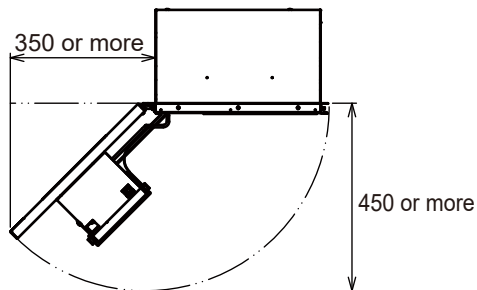

Unless otherwise specified, differences in the dimensions are specified as: General tolerance = \pm (Criteria of tolerance class IT18 in JIS B0401-1998)/2.

I/O terminals

Terminal block 1

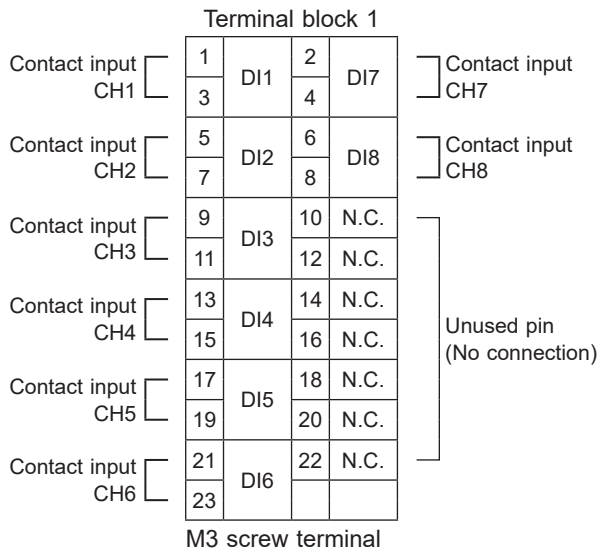

Terminal block 2

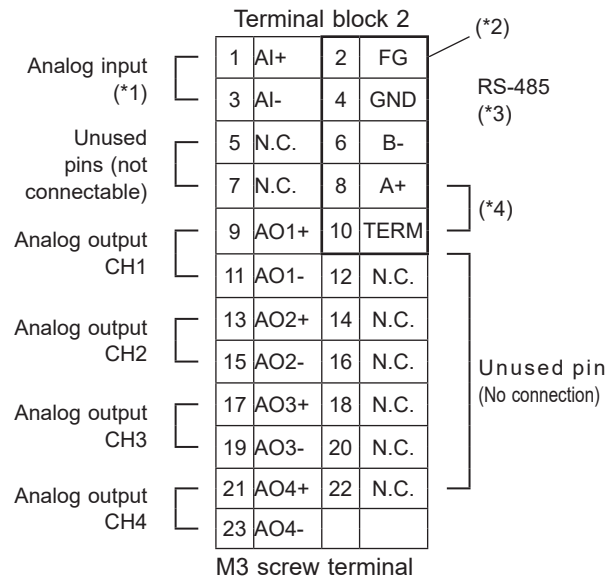

- *1: O₂ analyzer: available when "-1" or "-2" is selected.
- *2: Shield must be connected to FG terminal.
- *3: Digital communication: Available when -R is selected.
- *4: If termination is required, connect A+ and TERM.

Terminal block 3

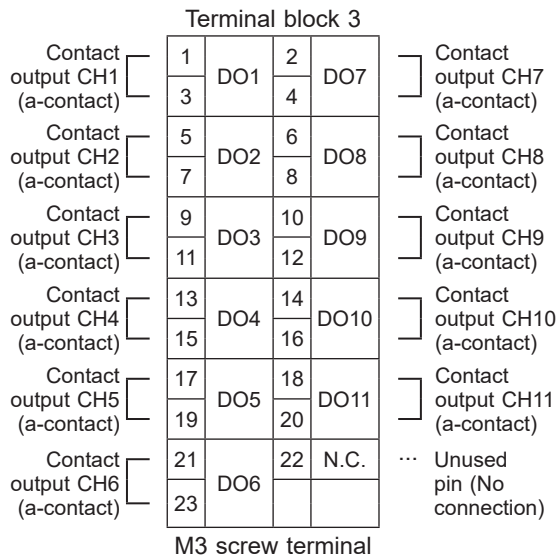

Terminal block 4

