

Model ZX8D Zirconia Oxygen Analyzer

IM 11G00E01-01EN

◆ Introduction

Thank you for purchasing the ZX8D Zirconia Oxygen Analyzer.

Please read the following respective documents before installing and using the ZX8D Zirconia Oxygen Analyzer.

The related documents are as follows.

General Specifications

Model	Contents	Document number	Note
IR202	Infrared Gas Analyzer	GS 11G02Q02-01EN	
IR400	NDIR TYPE INFRARED GAS ANALYZER (5-COMPONENT ANALYZER)	GS 11G02N01-01E	

The "E" or "EN" in the document number is the language code.

User's Manual

Model	Contents	Document number	Note
ZX8D	Zirconia Oxygen Analyzer	IM 11G00E01-01EN	(This manual)
IR202	Infrared Gas Analyzer	IM 11G02Q02-01EN	
IR400	Infrared Gas Analyzer	IM 11G02N01-01E	

The "E" or "EN" in the document number is the language code.

An exclusive User's Manual might be attached to the products whose suffix codes or option codes contain the code "Z" (made to customers' specifications). Please read it along with this manual.



WARNING

- This unit is not explosion-proof type. Do not use it in a place with explosive gases to prevent explosion, fire or other serious accidents.
- When noxious gases such as CO or other gases are contained in the calibration gas, be careful when venting or handling the instrument to avoid poisoning.
- When combustible gases are contained in measuring gas, check the gas composition and instrument specifications before use, or else the best performance may not be obtained or there may be a danger of explosion.



CAUTION

- This unit should be installed in a place which conforms to the conditions noted in the instruction manual. Otherwise, it may cause electric shocks, fire or malfunction of the unit.
 - During installation work, care should be taken to keep the unit free from entry of cable chips or other foreign objects. Otherwise, it may cause fire, trouble or malfunction of the unit.
 - The unit must be earthed as specified. Otherwise, it may cause electric shocks, malfunction, etc.
 - Be sure to use a power supply of correct rating. Connection of power supply of incorrect rating may cause fire.
 - Wiring work must be performed with all the power supplies to OFF to prevent electric shocks.
 - Use wiring materials that match the rating of the unit. Use of wiring materials out of rating may cause fire.
 - Wiring at a place which is exposed to water or rain, is prohibited in order to prevent electrical shock or damage to the instrument.
 - To avoid electrical shock, be sure to turn OFF the source power supply before work.
 - To prevent burning your hands, be sure to turn OFF the source power supply before cleaning the piping outlet. After power off, wait until the piping outlet cools down.
 - Beware of acid fluid inside the pipe. If acid fluid should contact your skin or clothes, immediately wash them with large amount of tap water. If they should splash onto your eyes, seek medical attention at once.
 - Do not use replacement parts other than those specified by the maker. Otherwise intended performance may not be obtained, or accidents or faults may result.
 - Replacement parts such as a maintenance part should be disposed of as incombustibles.
 - If the cause of any fault cannot be determined despite reference to the instruction manual, be sure to contact local sales representative or service office. If the instrument is disassembled carelessly, you may have a shock hazard or injury.
 - Do not use a replacement part other than specified by the instrument maker. Otherwise, adequate performance will not be provided. Besides, an accident or fault may be caused.
-

● Specification check

When the instrument arrives, unpack the package with care and check that the instrument has not been damaged during transportation. In addition, please check that the specification matches the order, and required accessories are not missing. Specifications can be checked by the model codes on the nameplate. Refer to Chapter 2 Specifications for the list of model codes.

◆ Safety Precautions

■ Safety, Protection, and Modification of the Product

- In order to protect the system controlled by the product and the product itself and ensure safe operation, observe the safety precautions described in this user's manual. We assume no liability for safety if users fail to observe these instructions when operating the product.
- If this instrument is used in a manner not specified in this user's manual, the protection provided by this instrument may be impaired.
- If any protection or safety circuit is required for the system controlled by the product or for the product itself, prepare it separately.
- Be sure to use the spare parts approved by Yokogawa Electric Corporation (hereafter simply referred to as YOKOGAWA) when replacing parts or consumables.
- Modification of the product is strictly prohibited.
- The following safety symbols are used on the product as well as in this manual.



WARNING

This symbol indicates that an operator must follow the instructions laid out in this manual in order to avoid the risks, for the human body, of injury, electric shock, or fatalities. The manual describes what special care the operator must take to avoid such risks.



CAUTION

This symbol indicates that the operator must refer to the instructions in this manual in order to prevent the instrument (hardware) or software from being damaged, or a system failure from occurring.

CAUTION

This symbol gives information essential for understanding the operations and functions.

NOTE

This symbol indicates information that complements the present topic.

■ Warning and Disclaimer

The product is provided on an "as is" basis. YOKOGAWA shall have neither liability nor responsibility to any person or entity with respect to any direct or indirect loss or damage arising from using the product or any defect of the product that YOKOGAWA can not predict in advance.

■ Notes on Handling User's Manuals

- Please hand over the user's manuals to your end users so that they can keep the user's manuals on hand for convenient reference.
- Please read the information thoroughly before using the product.
- The purpose of these user's manuals is not to warrant that the product is well suited to any particular purpose but rather to describe the functional details of the product.
- No part of the user's manuals may be transferred or reproduced without prior written consent from YOKOGAWA.
- YOKOGAWA reserves the right to make improvements in the user's manuals and product at any time, without notice or obligation.
- If you have any questions, or you find mistakes or omissions in the user's manuals, please contact our sales representative or your local distributor.

■ Drawing Conventions

Some drawings may be partially emphasized, simplified, or omitted, for the convenience of description.

Some screen images depicted in the user's manual may have different display positions or character types (e.g., the upper / lower case). Also note that some of the images contained in this user's manual are display examples.

■ Product Disposal:

The instrument should be disposed of in accordance with local and national legislation/regulations.

■ Trademark Acknowledgments

- All other company and product names mentioned in this user's manual are trademarks or registered trademarks of their respective companies.
- We do not use TM or ® mark to indicate those trademarks or registered trademarks in this user's manual.

◆ CE marking products

■ Authorized Representative in EEA

The Authorized Representative for this product in EEA is Yokogawa Europe B.V. (Euroweg 2, 3825 HD Amersfoort, The Netherlands).

■ Identification Tag

This manual and the identification tag attached on a packing box are essential parts of the product. Keep them together in a safe place for future reference.

■ Users

This product is designed to be used by a person with specialized knowledge.

■ Information of the WEEE Directive

This product is purposely designed to be used in a large scale fixed installations only and, therefore, is out of scope of the WEEE Directive. The WEEE Directive does not apply. This product should be disposed in accordance with local and national legislation/regulations. The WEEE Directive is only valid in the EU.

Model ZX8D

Zirconia Oxygen Analyzer

IM 11G00E01-01EN 8th Edition

CONTENTS

◆	Introduction.....	i
◆	Safety Precautions	iii
◆	CE marking products	v
1.	Overview.....	1
2.	Specifications	2
3.	Name and Description of Each Part	4
4.	Installation.....	5
	4.1 Mounting method.....	5
	4.2 Piping	6
	4.3 Sampling.....	7
	4.4 Wiring method.....	8
5.	Operation.....	9
	5.1 Operating procedure	9
	5.2 Preparation for operation.....	9
	5.3 Start of measurement.....	9
	5.4 Shutdown.....	9
6.	Maintenance.....	10
	6.1 Daily inspection.....	10
	6.2 Cleaning gas outlet.....	11
	6.3 Replacement of fuse.....	12
	6.4 Output characteristic.....	12
	Revision Information	i

1. Overview

The zirconia oxygen analyzer utilizes a solid electrolyte consisting mainly of zirconia (ZrO_2) which conducts only oxygen ions at a high temperature. It is an oxygen sensor which measures, based on the principle of an oxygen concentration cell, the electromotive force produced due to the difference in oxygen concentration between the measured gas and reference air. By combining this analyzer with a sampling system including an infrared gas analyzer, it can accurately measure oxygen concentration for a variety of applications including combustion equipment control, air separation plants and laboratory use.

2. Specifications

Measuring system:	Zirconia solid electrolyte
Measuring system:	Zirconia solid electrolyte
Measuring range:	Minimum range 0 to 5 vol% O ₂ and maximum range of 0 to 25 vol% O ₂ , if used in combination with infrared gas analyzer
Measurable component:	Oxygen in noncombustible gas or combustion exhaust gas (sensor will be burned and error will appear if combustible gas is mixed in sample gas)
Output signal:	4 to 20mA DC and 0 to 1V DC linear connected to infrared gas analyzer or direct output from sensor of the ZX8D.
Sensor output:	Logical output of zirconia sensor (with sensor temperature of 800°C) $E = 50.74 \log \frac{20.6}{X} - B$ <p>E: Logical output (mV) X: Measured gas concentration (%O₂) B: Blank voltage (mV)</p>
Temperature alarm output:	Contact output normally-closed contact, Contact capacity: 220V AC, 1A (resistive load)
Flow rate:	0.5±0.25 liter/minute (when connected with infrared gas analyzer)
NOTE :	The Zirconia system, due to its principle, may produce a measuring error due to relative concentration versus the combustible O ₂ gas concentration. Also, a corrosive gas (SO ₂ of 250 ppm or more, etc.) may affect the life of the sensor.
Warm up time:	Approx. 30 minutes
Ambient temperature:	0 to +45°C
Ambient humidity:	90% RH or less
Use environment:	Indoors
Mounting method:	Indoor wall mounting
Gas inlet/outlet:	Rc1/4 or 1/4NPT
Enclosure:	Steel casing
Indication:	Temperature indication (LED)
Outer dimensions (H×W×D):	141×170×190 mm
Mass:	Approx. 3 kg
Finish color:	Munsell 5Y7/1
Power supply	
Rated voltage:	100 to 115 V AC or 200 to 240V AC
Rated frequency:	50 Hz/60 Hz
Power consumption:	Max. 215 W. Approx. 65 W for ordinary use.
Fluctuation of power supply voltage:	230V AC ±10%
Repeatability:	±0.5% FS (when connected with infrared gas analyzer)
Linearity:	Within ± 1% of full scale
Zero drift:	Within ± 1% of full scale/week
Span drift:	Within ± 2% of full scale/week
Response speed:	Approx. 20 seconds for 90% response (when connected with infrared gas analyzer)

Safety, EMC and RoHS conforming standards (Only ZX8D-□*D)

Installation altitude: 2000 m or less

Pollution degree: 2

Installation category: II

Note: Installation category, called overvoltage category, specifies impulse withstanding voltage. Category II is for electrical equipment. Pollution degree indicates the degree of existence of solid, liquid, gas or other inclusions which reduce dielectric strength. Degree 2 is the normal indoor environment.

Safety: EN61010-1

EMC: EN61326-1 Class A, Table 2 (For use in industrial locations), EN61326-2-3, EN61000-3-2, EN61000-3-3

EMC Regulatory Arrangement in Australia and New Zealand

Korea Electromagnetic Conformity Standard Class A 한국 전자파적합성 기준

Note: The product mounted in a steel enclosure conforms to the requirements of EMC directive.

Caution: The instrument is a Class A product, and it is designed for use in the industrial environment. Please use this instrument in the industrial environment only.

RoHS: EN IEC 63000

Information of the WEEE Directive

This product is purposely designed to be used in a large scale fixed installations only and, therefore, is out of scope of the WEEE Directive. The WEEE Directive does not apply. The WEEE Directive is only valid in the EU.

■ Model and Suffix codes

Model	Suffix code	Option code	Description
ZX8D	-----	-----	Zirconia Oxygen Analyzer
Power supply	-3	-----	200-240 V AC, 50/60 Hz
	-5	-----	100-115 V AC, 50/60 Hz
Style code		*C	For IR202, IR400
		*D	For IR202, IR400 (CE conformity)

3. Name and Description of Each Part

■ Name and description of each part on case

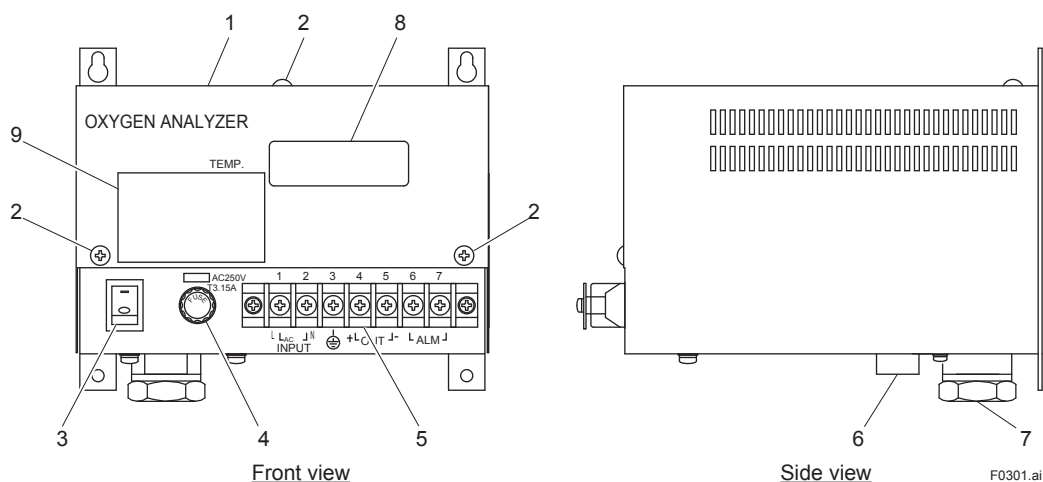

No.	Name	Function
1	Case cover	Protects the internal components.
2	Retaining screw	Fix the case cover.
3	Main switch	Turn ON to supply power to the interior.
4	Fuse	250V AC/3.15A
5	Terminal board	Used to connect input/output
6	Sample gas inlet	Connect tube for gas to be measured. (Rc1/4 internal thread or 1/4NPT internal thread)
7	Sample gas outlet	Connect tube for discharging measured gas. (Rc1/4 internal thread or 1/4NPT internal thread)
8	Temperature indicator	Indicates the sensor temperature.
9	Specification nameplate	Indicates type and specifications.

■ Name and description of internal parts

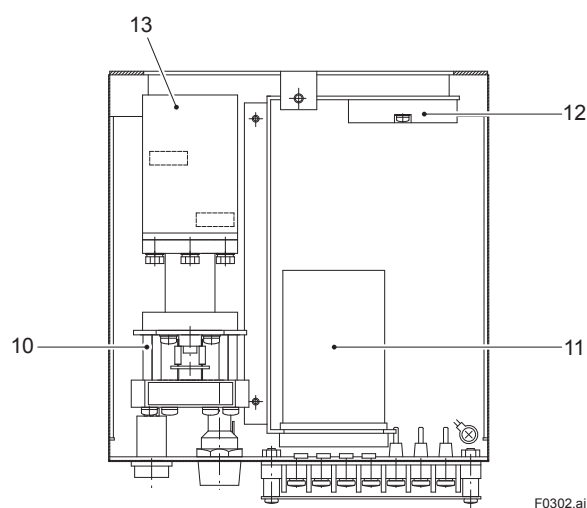

No.	Name	Function
10	Oxygen sensor	Provides output according to oxygen concentration in sample gas.
11	Temperature controller	Controls heater of oxygen sensor at operating temperature of 800°C.
12	Relay	Control relay for heater.
13	Gas feeding case	Introduces gas to be measured to the oxygen sensor.

4. Installation

WARNING

This unit is not explosion-proof type. Do not use it in a place with explosive gases to prevent explosion, fire or other serious accidents.

CAUTION

This unit should be installed in a place which conforms to the conditions noted in the instruction manual. Otherwise, it may cause electric shocks, fire or malfunction of the unit.

4.1 Mounting method

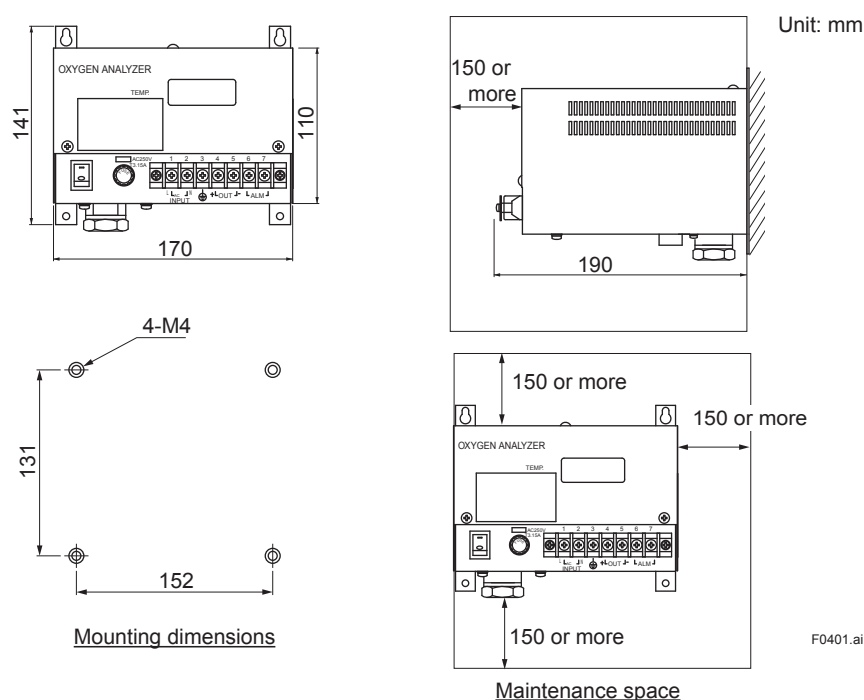

- Mount the unit on a metal plate, such as steel plate, of more than 3 mm thick using M4 screws or bolts. Do not mount it on materials such as plasterboard or lumber, which do not have sufficient strength for mounting. If the unit is to be mounted on a metal plate of less than 3 mm thick, it is recommended to fix the unit using nuts.
- Mount on a vertical wall with the gas inlet and outlet facing down.
- Provide space for maintenance and heat dissipation at the top, bottom, front and right side.
- To protect the oxygen sensor, avoid supplying power with the front of the unit facing upward.
- Select a proper installation location.
- Select a place where temperature will not fluctuate too much, and remains near the normal temperature and humidity.
- Select a place which is free from heat radiation or direct sunlight.

- This analyzer is of an indoor structure. When installing outdoors, select a place which is not exposed to rain or water or use a protective cover.
- Select a clean place which is free from corrosive gas or combustible gas.
- You must install external power switch or Circuit breaker for the power supply.
- Install the external switch or the Circuit breaker in the same room where the ZX8D is installed. Place it where the operator can access and indicate that it is the Circuit breaker of the ZX8D.
- The external power supply switch or the Circuit breaker must comply with a current rating of ZX8D.

4.2 Piping

Connect pipes to the gas inlet and outlet at the bottom of the unit.

Use anticorrosive tubes such as Teflon, stainless steel or polyethylene for connecting this instrument and the sampling system.

The inlet pipe should be kept as short as possible to allow a fast response. A suitable inner diameter is around 4 mm. The pipes and joints should be clean, because dust entering the instrument may cause faulty operation.

Since sulfuric acid mist or oxides may be discharged through the outlet pipe, this pipe should have an inner diameter of about 8mm and be easily detachable for cleaning. A branch should also be provided midway on this pipe for eliminating mist and the like. The outlet pipe should be open to the atmosphere to avoid connecting it to another analyzer, sampling device, etc.

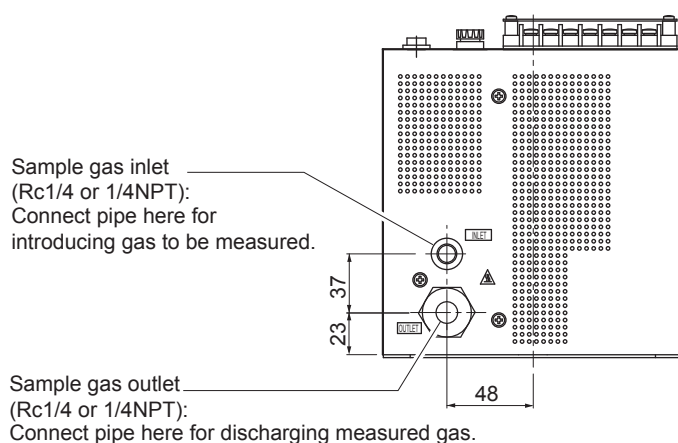

F0402.ai

■ Piping configuration diagram

Following is a typical example of piping.

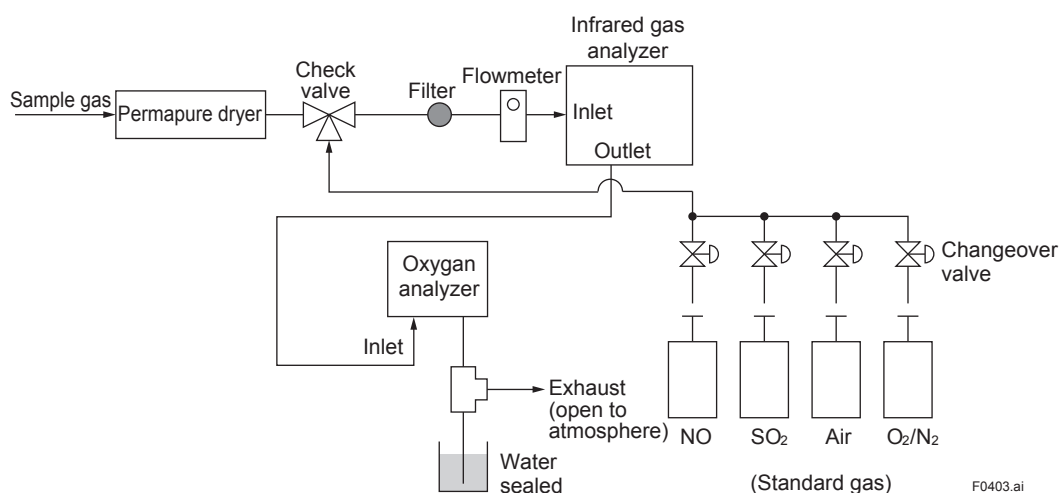

4.3 Sampling

WARNING

- This unit is not explosion-proof type. Do not use it in a place with explosive gases to prevent explosion, fire or other serious accidents.
- When combustible gases are contained in measuring gas, check the gas composition and instrument specifications before use, or else the best performance may not be obtained or there may be a danger of explosion.

■ Sample gas conditions

- Dust included in sample gas should be completely eliminated with a filter. Use a filter capable of eliminating dust particles of 0.3 μm at the final stage.
- The dew point of sample gas must be lower than the ambient temperature to avoid condensation of drain inside the analyzer. If water vapor is included in sample gas, then use a dehumidifier to lower the dew point to about 0°C.
- If SO_3 mist is included in sample gas, then use a mist filter, cooler or the like to exclude it. Other types of mist should also be excluded.
- Strongly corrosive gases like Cl_2 , F_2 and HCl included in sample gas will shorten the service life of the instrument. Harmful components such as Si vapor, alkaline metals, P, Pb and SO_2 at high concentrations (1000ppm or more) will also shorten its service life.
- Sample gas temperature should range from 0 to 50°C. Do not introduce a high temperature gas directly into the instrument.
- Combustible gases such as H_2 and CO included in sample gas will consume O_2 via a reaction and produce a measuring error.

■ Sample gas flow rate

Set the sample gas flow rate at 0.5 ± 0.25 L/min.

■ Preparation of standard gas

Prepare standard gas for zero point and span calibration.

Zero gas (span gas in rule of measuring)	Air
Span gas (zero gas in rule of measuring)	1 to 2% O_2/N_2

4.4 Wiring method



CAUTION

- Wiring work must be performed with all the power supplies to OFF to prevent electric shocks.
- Be sure to perform class D grounding. Otherwise electric shock or malfunction may result.
- During installation work, care should be taken to keep the unit free from entry of cable chips or other foreign objects. Otherwise, it may cause fire, trouble or malfunction of the unit.
- Use wiring materials that match the rating of the unit. Use of the wiring materials out of rating may cause electric shocks or fire.
- Be sure to use a power supply of correct rating. Connection of power supply of incorrect rating may cause fire.
- Wiring at a place which is exposed to water or rain, is prohibited in order to prevent electrical shock or damage to the instrument.

External terminals are provided on the front of the instrument. Make connection to these terminals according to Figure 4.1. Be sure to perform class D grounding.

Terminal screws are M4. Keep the power supply wiring to 3 m or shorter, and use a polyvinyl chloride wire of 1.25 sq for 600V or equivalent.

Use shielded wiring for the output signal to reduce the influence of external noise.

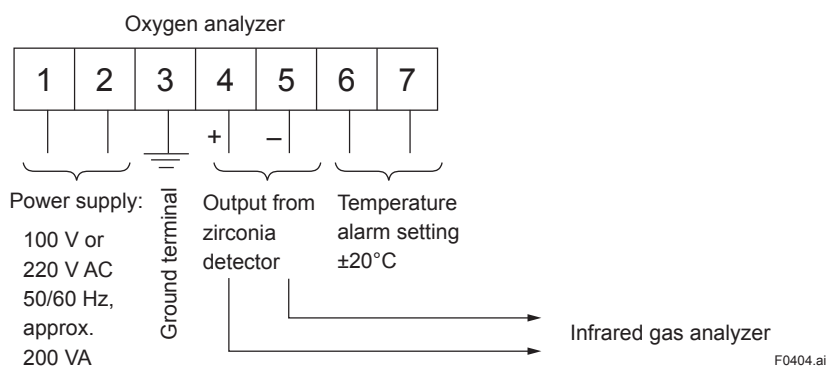

Figure 4.1 External wiring

5. Operation



WARNING

- When noxious gases such as CO or other gases are contained in the calibration gas, be careful when venting or handling the instrument to avoid poisoning.
 - When combustible gases are contained in measuring gas, check the gas composition and instrument specifications before use, or else the best performance may not be obtained or there may be a danger of explosion.
-



CAUTION

- Do not use a replacement part other than specified by the instrument maker. Otherwise, adequate performance will not be provided. Besides, an accident or fault may be caused.
 - Wiring at a place which is exposed to water or rain, is prohibited in order to prevent electrical shock or damage to the instrument.
-

5.1 Operating procedure

Read through the instruction manual for the infrared gas analyzer to be combined with this analyzer, then proceed to operation accordingly.

The oxygen analyzer requires a warmup of at least 30 minutes.

5.2 Preparation for operation

- (1) Check of piping and wiring

Make sure all the piping and wiring have been made correctly.

- (2) Turning on power

Turn on the power switch and the temperature will be indicated.

- (3) Warmup

Flow zero gas (air) and warm up the instrument for at least 30 minutes. The warmup is finished when the temperature reaches $800\pm 5^{\circ}\text{C}$.

- (4) Calibration

Calibrate the zero point (air) and span with reference to the instruction manual for the infrared gas analyzer.

5.3 Start of measurement

Flow the sample gas into the instrument.

5.4 Shutdown

When shutting down the instrument, supply air or the like for at least 5 minutes to replace the measured gas inside the sensor.

The turn OFF the power switch.

6. Maintenance



WARNING

When noxious gases such as CO or other gases are contained in the calibration gas, be careful when venting or handling the instrument to avoid poisoning.



CAUTION

- If the cause of any fault cannot be determined despite reference to the instruction manual, be sure to contact local sales representative or service office. If the instrument is disassembled carelessly, you may have a shock hazard or injury.
 - To avoid electrical shock, be sure to turn OFF the source power supply before work.
 - To prevent burning your hands, be sure to turn OFF the source power supply before cleaning the piping outlet. After power off, wait until the piping outlet cools down.
 - Do not use replacement parts other than those specified by the maker. Otherwise intended performance may not be obtained, or accidents or faults may result.
 - Replacement parts such as a maintenance part should be disposed of as incombustibles.
 - Do not use a replacement part other than specified by the instrument maker. Otherwise, adequate performance will not be provided. Besides, an accident or fault may be caused.
 - Wiring at a place which is exposed to water or rain, is prohibited in order to prevent electrical shock or damage to the instrument.
-

6.1 Daily inspection

■ Zero point (air) and span calibration

- (1) Calibrate the zero point according to the instruction manual for the infrared gas analyzer.
- (2) Calibrate the span following zero point calibration.
- (3) Zero point and span should be calibrated about once a week as required.

■ Check of flow rate

Check once a day if sample gas flow rate is 0.5 ± 0.25 L/min.

■ Check of analyzer output and temperature indication

● Oxygen analyzer output

If the response is delayed or the oxygen indication does not change, then check for disconnected piping or clogging of the outlet pipe, etc.

● Temperature indication

- Check if the temperature indication is in a range of $800 \pm 5^\circ\text{C}$.
- If the temperature indicator shows “UUUU”, then wiring may be disconnected or a thermocouple may be broken.

Check for continuity between 3 and 4 of the oxygen sensor - it should be around 2Ω .
When disconnected, replace the oxygen detector.

6.2 Cleaning gas outlet

Sulfate mist or oxide may be precipitated at the pipe output, depending on the components of measuring gas.

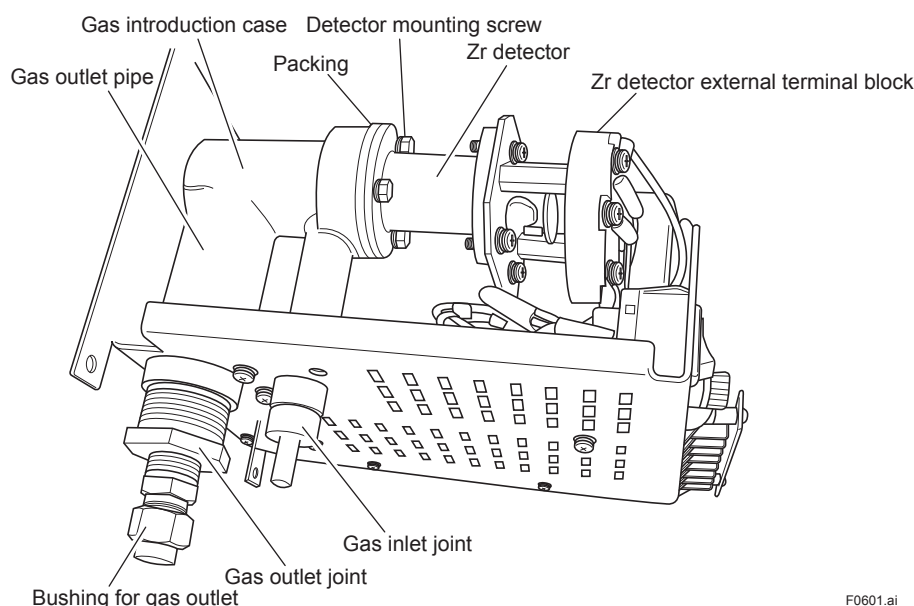

F0601.ai

Clean the pipe according to the following procedure.

- (1) After supplying atmospheric air or N₂ standard gas for at least 5 minutes in the oxygen analyzer, set the power supply and main unit power supply switch to OFF.
- (2) Remove the inlet pipe of oxygen analyzer, and exhaust the gas to outside.
Beware of ventilation when sample gas contains a toxic component such as CO or SO₂.
- (3) Remove the outlet pipe and bushing of oxygen analyzer. Place a drain receiver on the bottom part.

CAUTION

Beware of acid fluid inside the pipe. If acid fluid should contact your skin or clothes, immediately wash them with large amount of tap water. If they should splash onto your eyes, seek medical attention at once.

- (4) Eliminate and clean the precipitates inside the gas outlet pipe with driver or absorbent cotton. Be careful not to damage the tip of detector.
- (5) Reconnect the pipe as before, paying attention not to cause gas leakage. Check the indication of flow meter.
- (6) Turn on the power switch and warm up oxygen analyzer.

6.3 Replacement of fuse

CAUTION

Be sure to find the cause of the blowout and take necessary measures before replacing the fuse.

- (1) Turn off the power switch.
- (2) The fuse is located at the lower left viewed from the front. Pull up the cap of the fuse holder while rotating it counterclockwise, and the cap and the fuse are detached.
- (3) Replace the fuse with a new one (Fuse: 250V AC / 3.15A delay type).
- (4) Then fasten the cap of the fuse holder.

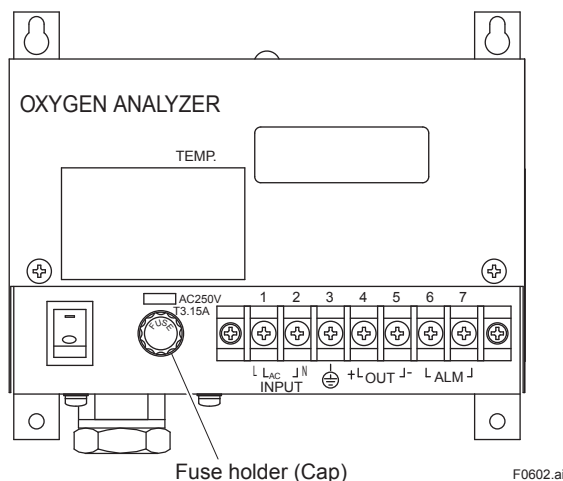

6.4 Output characteristic

Table 1 ZX8D output characteristic

%O ₂	OUTPUT (mV)	%O ₂	OUTPUT (mV)
0.01	168.57	7.0	24.21
0.02	153.3	8.0	21.27
0.03	144.36	9.0	18.67
0.04	138.02	10.0	16.35
0.05	133.1	11.0	14.25
0.1	117.83	12.0	12.33
0.2	102.56	13.0	10.57
0.3	93.62	14.0	8.93
0.4	87.28	15.0	7.41
0.5	82.36	16.0	5.99
0.6	78.35	17.0	4.66
0.7	74.95	18.0	3.40
0.8	72.01	19.0	2.21
0.9	69.41	20.0	1.08
1.0	67.09	20.6	0.4238
2.0	51.82	21.0	0
3.0	42.88	22.0	-1.025
4.0	36.54	23.0	-2.005
5.0	31.62	24.0	-2.943
6.0	27.61	25.0	-3.84

E (OUTPUT: mV) = 50.74 log 21/O₂%

Revision Information

- Manual Title : Model ZX8D Zirconia Oxygen Analyzer

- Manual No. : IM 11G00E01-01EN

July 2022 /8th Edition

Added some notes (P.4)

June 2021 /7th Edition

Revised RoHS conformity standards. (p.3)

May 2018 / 6th Edition

Added WEEE directive information. (p.v, p.3)

Deleted IR200 (p.i, p.3)

Corrected errors (p.3)

Nov. 2017 / 5th Edition

Revised a description on power supply. (p.2)

Aug. 2017 / 4th Edition

Added RoHS. (p.3)

June 2017 / 3rd Edition

Revised due to the discontinuation of IR250.(p.i, p.3) for a model change into IR202.

Mar. 2017 / 2nd Edition

Added IR250 with some revision and so forth. (p.i,p.v, p.2, p.3, p.5)

Feb. 2016 / 1st Edition

Newly published

Yokogawa Electric Corporation
2-9-32 Nakacho, Musashino-shi, Tokyo 180-8750, JAPAN
<http://www.yokogawa.com/>
