



Blank Page

Preface

This document introduces you to the fundamentals of the optional FOUNDATION Fieldbus functionality of the DAQSTATION.

There are several types of fieldbus (or field bus) in the world, such as FOUNDATION Fieldbus, Profibus, and Device Net; however, throughout this document, the word fieldbus refers to the FOUNDATION Fieldbus.

NI-FBUS Configurator 2.3 and NI-FBUS, applications used in the procedures within this document, are products of National Instruments Corporation.

Blank Page

Fundamentals of FOUNDATION™ Fieldbus Functionality of DAQSTATION

TI 04L01A01-13E 2nd Edition

CONTENTS

Preface	i
1. Field Networks	1-1
1.1 Changes of Field Networks	1-2
1.2 Merits of Fieldbus	1-3
2. Fieldbus	2-1
2.1 H1 Fieldbus (31.25 k bps) Wiring	2-2
2.2 Devices	2-4
2.3 Configurator	2-5
2.4 Files Supplied for Fieldbus Engineering	2-7
3. Example of Setting (NI-FBUS Configurator)	3-1
3.1 Getting Started	3-2
3.1.1 Interface Configuration Utility (Interface Config)	3-3
3.1.2 NI-FBUS Interface Driver	3-6
3.1.3 NI-FBUS Configurator	3-7
3.2 Making Settings	3-8
3.2.1 Setting Tags and Addresses	3-9
3.2.2 Creating Link	3-10
3.2.3 Scheduling Function Block Execution Times and Data Transmission	3-11
3.2.4 Downloading Configuration	3-12
3.2.5 Mapping	3-13
3.3 Checking Operation	3-17
3.3.1 Monitoring Transmissions	3-17
3.3.2 Checking Displayed Data	3-18
4. Example of Setting (CENTUM FIELDBUS ENGINEERING TOOL)	4-1
4.1 Getting Started	4-2
4.1.1 Fieldbus Support Tool for DAQSTATION	4-2
4.2 Making Settings	4-3
4.2.1 Setting Up Fieldbus Engineering Tool	4-4
4.2.2 Setting Up the Project and Fieldbus Device	4-9
4.2.3 Creating a FBAP Configuration Diagram	4-16
4.2.4 Downloading the FBAP Configuration	4-24

5.	Appendix	5-1
5.1	NI-FBUS Error Codes	5-1

1. Field Networks

Field networks are the basis of the inter-linking network hierarchy in an industrial plant, and connect field devices such as sensors and actuators, and control and monitoring systems such as controllers and host computers, to each other.

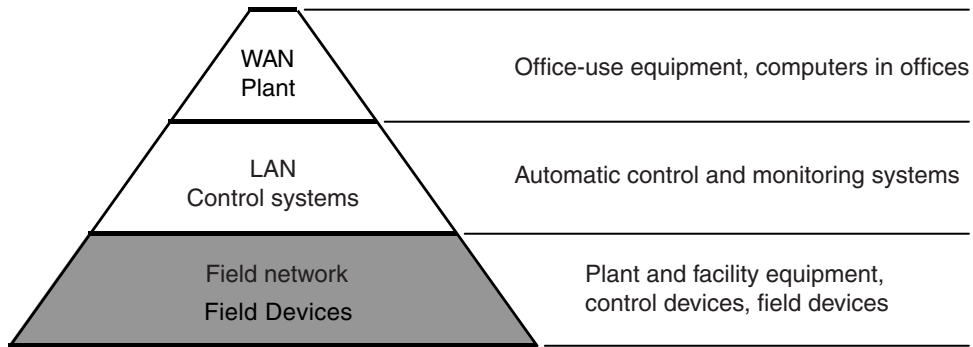

Figure 1. Plant Network Hierarchy

Several types of communication methods for field networks, including pneumatic signal transmission and analog signal transmission, were developed from the aspects of response and safety, or from an economical viewpoint or historical background.

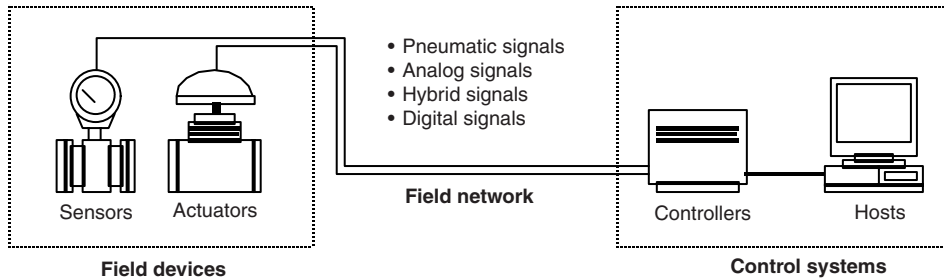

Figure 2. Transmission Methods for a Field Network

1.1 Changes of Field Networks

The changes in the popularity of field network types are shown below. Although old-fashioned pneumatic and analog signal transmission methods are still used now, the mainstream is shifting towards digital signal transmissions in line with the functional enhancement of devices and the world trend of networking.

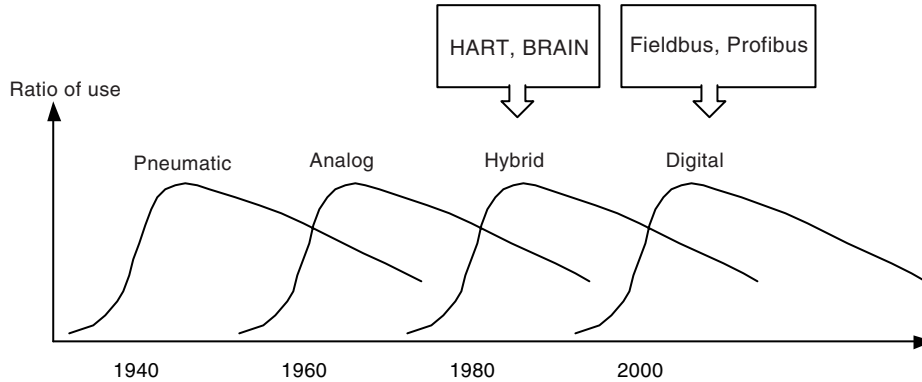

Figure 3. Changes in Popularity of Field Network Types

The fieldbus connectivity incorporated in a DAQSTATION complies with FOUNDATION Fieldbus, which is one of the international standards for field networks based on digital signal transmissions and can connect multiple sensing devices and control devices to each other while allowing for bi-directional digital transmissions.

Table 1. Transmission Methods for a Field Network

Type	Pros and Cons
Pneumatic signal	Intrinsically safe because of no sparking device, so is used even at present in environments where an inflammable gas exists. Associated with a large propagation delay. Costs high due to the need for a compressor(s).
Analog signal	Uses an electric signal in place of a pneumatic signal. Unified analog signals such as 0–5 V, 1–5 V, and 4–20 mA DC are most often used.
Hybrid signal	Uses a 4–20 mA DC analog signal with digital signals superimposed in it. Can transmit parameter settings in addition to a process variable.
Digital signal	Transmits all parameters including process variables in the form of digital signals in accordance with a standardized protocol, assuring high interoperability.

1.2 Merits of Fieldbus

Configuring a field network with a fieldbus delivers the following merits to the plant in comparison to a traditional method:

- Slashed wiring cost resulting from a multidrop topology
- Distributed and downsized control systems
- Transmissions of diversified information allowed by digital communications
- Standardized operation and high interoperability by use of standardized function block interfaces

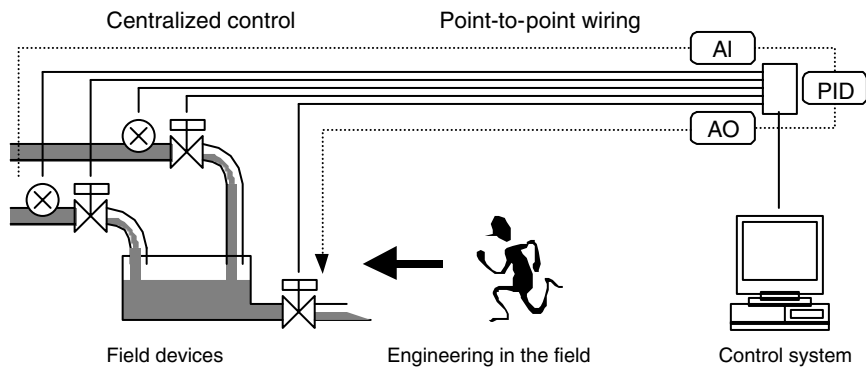

Figure 4. Instrumentation before Fieldbus

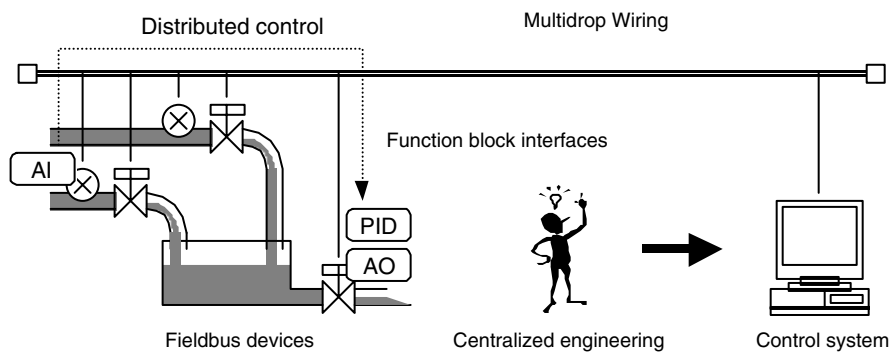

Figure 5. Fieldbus-based Instrumentation

Blank Page

2. Fieldbus

There are two types of Fieldbus specifications stipulated by Fieldbus FOUNDATION: H1 for a low-speed fieldbus and H2 for a high-speed fieldbus. Nevertheless, since the H2 fieldbus solution is regarded as having failed to catch up with the current trend of the times, there has been a shift from H2 to high-speed Ethernet-based specifications, abbreviated HSE. HSE, however, is currently under study and only a prototype has been presented. Accordingly, the fieldbus type supported by current devices including the DAQSTATION is H1.

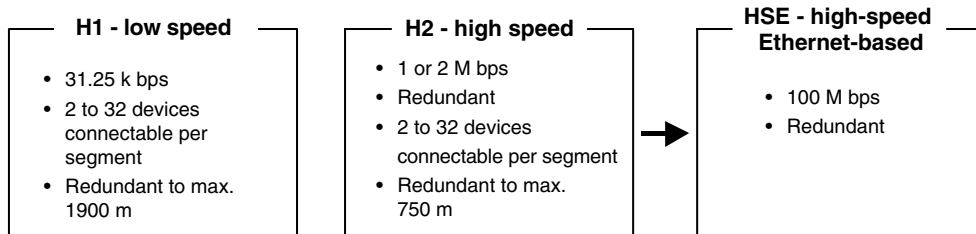

Figure 6. Fieldbus Types

An H1 fieldbus means a fieldbus network operating at 31.25 k bps, designed for low-speed processes such as temperature, liquid level, and flow rate control. Up to 32 devices can be connected on each H1 fieldbus segment. Devices can be powered directly from the fieldbus and operate by having the power supply and signals carried through the H1 cable previously used for 4 – 20 mA devices, allowing effortless transition from a conventional system.

2.1 H1 Fieldbus (31.25 k bps) Wiring

An H1 fieldbus segment allows the use of spurs branched from a stub on the trunk cable, as shown in the figure below. A terminator must be installed at both ends of the trunk cable. When using a device to be powered from the fieldbus, a power supply must be connected to the trunk.

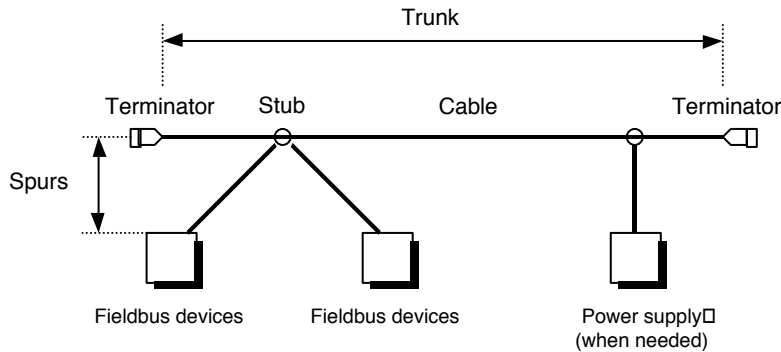

Figure 7. H1 Fieldbus (31.25 k bps) Wiring

The total length of an H1 fieldbus segment is limited by various factors including the type of cable used, whether a power supply is needed, and whether the network is required to be intrinsically safe (I.S.).¹ Also, the number of connectable devices is limited by the type of cable used, total power consumption of the devices, whether a repeater is used, and so on. The following are general limitations for an H1 fieldbus segment:

- Total cable length = trunk cable length + total length of each spur \leq 1900 m (when using Type A cable)
- Only one device can be connected per spur.
- The maximum total spur length is reduced by 30 m for each additional connected device (see Table 2).
- The maximum number of devices that can be connected on each segment is 32.

1: When an intrinsically safe fieldbus is required, intrinsic safety (I.S.) barriers also need to be installed.

Although 32 devices can be connected on an H1 segment, in practical use, connecting 10 devices on an H1 segment and carrying out transmissions at short intervals exhausts the resources.²

- 2: The network should be carefully designed while taking into account that H1 segments are relatively low-speed (31.25 k bps) communication paths.

Table 2. Maximum Total Spur Length Depending on Number of Devices

Number of Devices	Maximum Total Spur Length in meters
1 to 12	120
13 to 14	90
15 to 18	60
19 to 24	30
25 to 32	1

Table 3. Cable Types

Cable Type	Total length in meters (feet)	Description
Type A	1900 (6270)	Each twisted pair has a shield.
Type B	1200 (3960)	Multiple twisted pairs with overall shield
Type C	400 (1320)	Multiple twisted pairs, no shield
Type D	200 (660)	Multiple conductor cable with overall shield, no pairing of wires

2.2 Devices

The Data Link layer of the fieldbus specifications stipulates three types of devices: bridges, link masters (LMs), and basic devices. However, at present, since bridges are available only as prototypes and have not yet been made for practical use, a fieldbus device always means a link master or basic device.

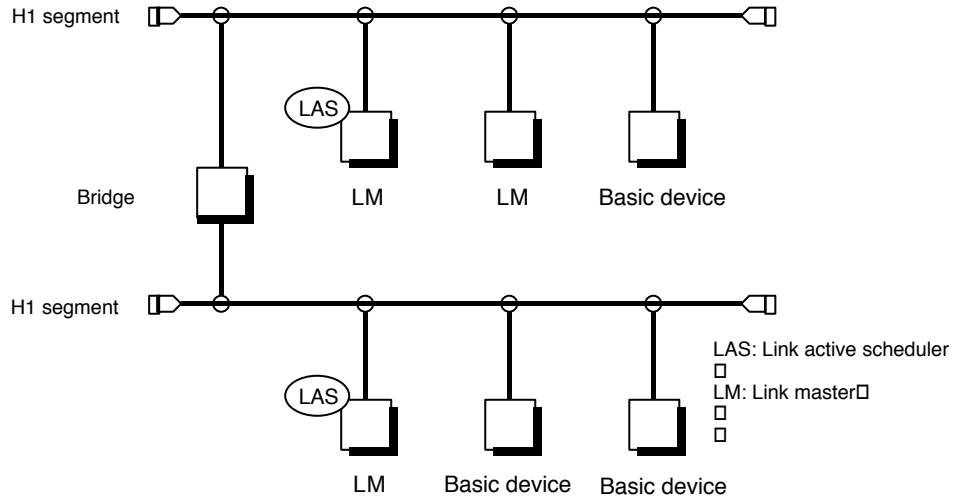

Figure 8. Device Types

Table 4. Device Types

Bridge	Connects an H1 segment to another. (No product available at present.)
Link master (LM)	Any device containing Link Active Scheduler (LAS) functionality that can control communications on an H1 fieldbus link. There must be at least one LM on an H1 link; one of those LM devices will be elected to serve as LAS and the others serve as backups.
Basic device	Any device not containing Link Active Scheduler functionality

2.3 Configurator

Fieldbus engineering is simple but requires extensive settings to be made, so software generally referred to as a configurator is usually used to have repetitive operations done automatically. The main purpose of a configurator is the management of communication and device settings such as, link, tag, address, and other parameter settings.

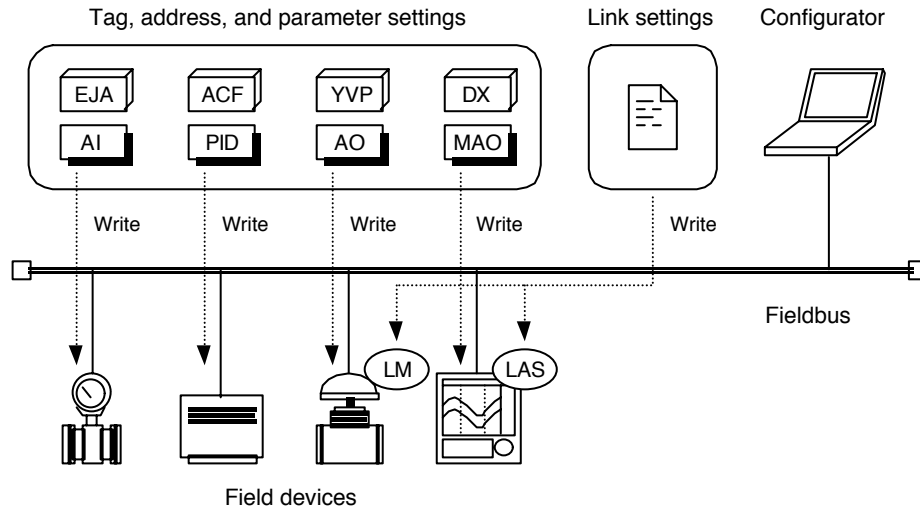

Figure 9. Tag, Address, Parameter, and Link Setting Using Configurator

To enable communications on a fieldbus, all devices need to be assigned a physical device (PD) tag, block tag, node address, all of which are unique on the segment. Also, for each device, the link settings and block parameters need to be adjusted depending on the type and purpose of the device. A configurator works as a user interface to display and modify these settings.

Other purposes of a configurator are to set up and download links between function blocks (FBs) and the communications schedule as well as the device control sequence.

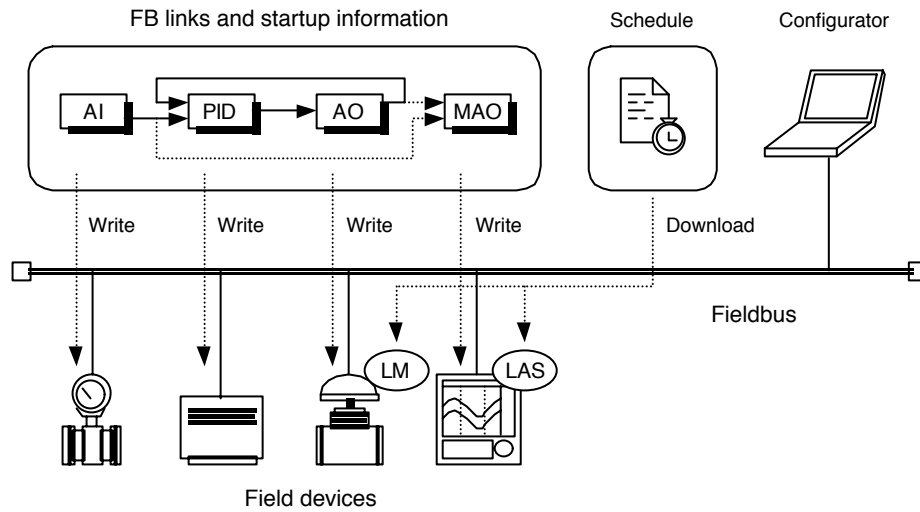

Figure 10. FB Link Setting and Schedule Downloading

To enable communications on a fieldbus segment, FB execution start times and links between FBs need to be determined, and the time schedule of data transmissions between FBs needs to be drawn and downloaded to all LMs on the segment. A configurator works as a tool to create and optimize these settings.

2.4 Files Supplied for Fieldbus Engineering

To help engineering using a configurator, two types of files called the device description (DD) file and capabilities files (former "resource files") are supplied for each device model from the device manufacturers.

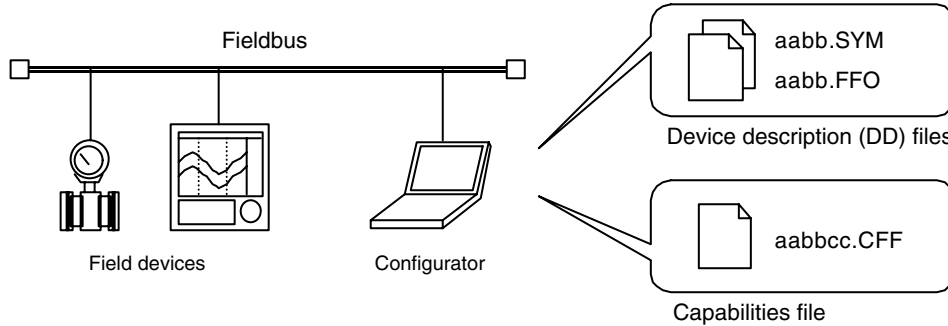

Figure 11. Files for Fieldbus Engineering

In a configurator, install the above files containing the device revision number that agrees with the DEV_REV value of the corresponding field device used, and the DD revision number that is greater than the DD_REV value of the corresponding field device.³

3: If two or more files having the identical device revision number but having a different DD revision number are installed, a configurator uses the file with the latest DD revision.

Table 5. Files for Fieldbus Engineering

File	Description
Device description (DD) files <i>aabb.SYM</i> <i>aabb.FFO</i> where <i>aa</i> = device revision <i>bb</i> = DD revision	A DD file includes information needed for a configurator to understand the meaning of device data to display them, and provides an extended description of each vendor-specific object in the device.
Capabilities file <i>aabbcc.CFF</i> where <i>aa</i> = device revision <i>bb</i> = DD revision <i>cc</i> = capabilities file revision	A capabilities file describes the capabilities of a particular fieldbus device model. Capabilities files are requisite to configuring a fieldbus system without having the fieldbus devices online, i.e., for offline configuration.

The differences in appearances of device data depending on whether the DD file is installed when using a configurator of National Instruments, are shown below. Even without the DD file that provides the information needed for a configurator to understand the meaning of device data, the user can make settings but can only see and set meaningless numbers and values.

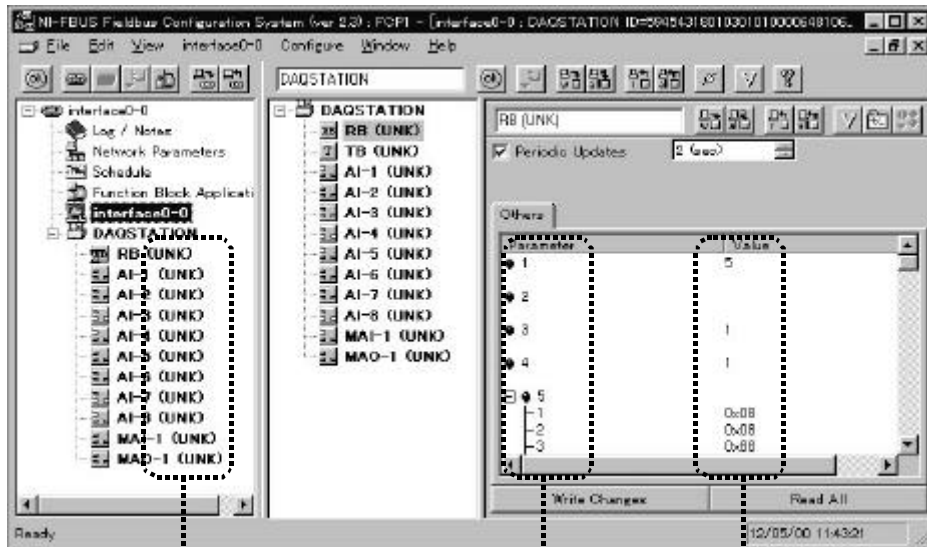

No profile of each FB displayed

Meaningless values displayed

Parameters displayed unnamed

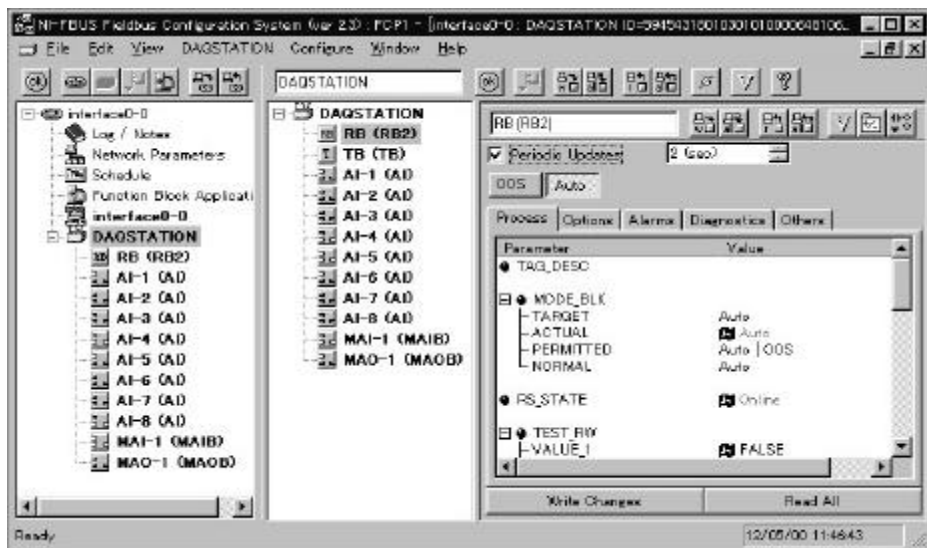

Figure 12. With (lower) and Without (upper) DD File

3. Example of Setting (NI-FBUS Configurator)

As an example of setting a fieldbus system with a DAQSTATION, the following introduces the procedure using a configurator of National Instruments (hereinafter referred to as NI) to create a simple application to display the primary process value of a transmitter on the DAQSTATION's screen.

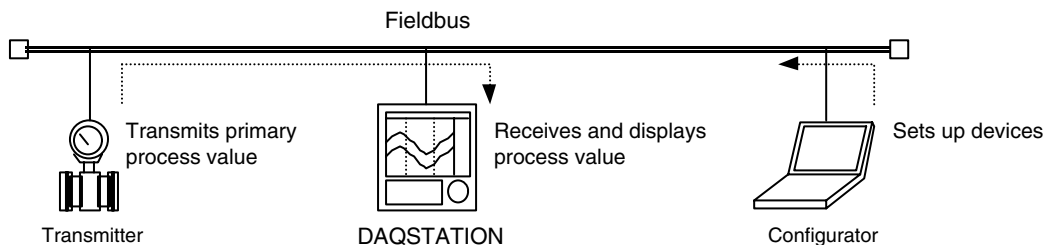

Figure 13. Creating a Simple Application

The table lists equipment used to create this application. Albeit an EJA is listed as the transmitter, a different transmitter model can be used absolutely. Although no specifications are given for the wiring hardware such as the fieldbus cable, power supply, or terminators, use the hardware compliant to the FOUNDATION Fieldbus specifications.

Table 6. Equipment Needed to Create the Example Application

Name	Model
Configurator	NI-FBUS Configurator ver. 2.3
Transmitter	EJA fieldbus version 2.01
DAQSTATION	DAQSTATION fieldbus version 3.01
Wiring	H1 fieldbus cable
	Power supply (required because both the EJA and DAQSTATION need to be powered from the fieldbus).
	Terminator

3.1 Getting Started

The following describes the procedure from installing NI-FBUS Configurator to running it. Installing NI-FBUS Configurator adds a group of shortcuts, shown below, in the **Start** menu of your PC.⁴

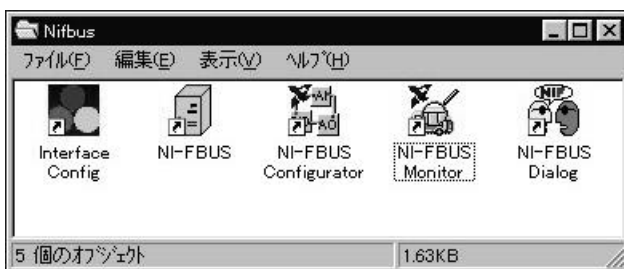

Figure 14. Shortcuts to NI-FBUS Configurator and Accompanying Applications

To run NI-FBUS Configurator, which is used in the consequent procedure, NI-FBUS must be running as a background task. Since the actions of NI-FBUS are set in Interface Configuration Utility (accessed from the Interface Config shortcut icon), you need to run **Interface Configuration Utility** first, then NI-FBUS, NI-FBUS Configurator.⁵

- 4: The **NI-FBUS Monitor** shortcut icon may not be seen and is not used in this example.
- 5: If the settings for NI-FBUS need no change after the first time, you do not have to run and make settings in Interface Config from the second and consequent times. The settings are saved to a file or the registry.

Table 7. NI-FBUS Configurator and Accompanying Applications

Shortcut	Application
Interface Config	NI-FBUS Interface Configuration Utility; used to set up interface card operation.
NI-FBUS	Driver for an NI-FBUS interface card
NI-FBUS Configurator	Configurator for a fieldbus system connected via an NI-FBUS interface card.
NI-FBUS Monitor	Application for monitoring fieldbus protocol-based transmissions over an NI-FBUS.
NI-FBUS Dialog	Interactive parameter setting tool for a fieldbus system connected via an NI-FBUS interface card

3.1.1 Interface Configuration Utility (Interface Config)

What you have to do in Interface Configuration Utility are listed in the table below. Note that the changes you made to the settings in Interface Configuration Utility will be put into effective only after NI-FBUS is restarted.

Table 8. What to Do in Interface Configuration Utility

Import of DD	Install the dictionary and device description (DD) files.
Stack configuration	Set the communication stack parameters for the interface card.

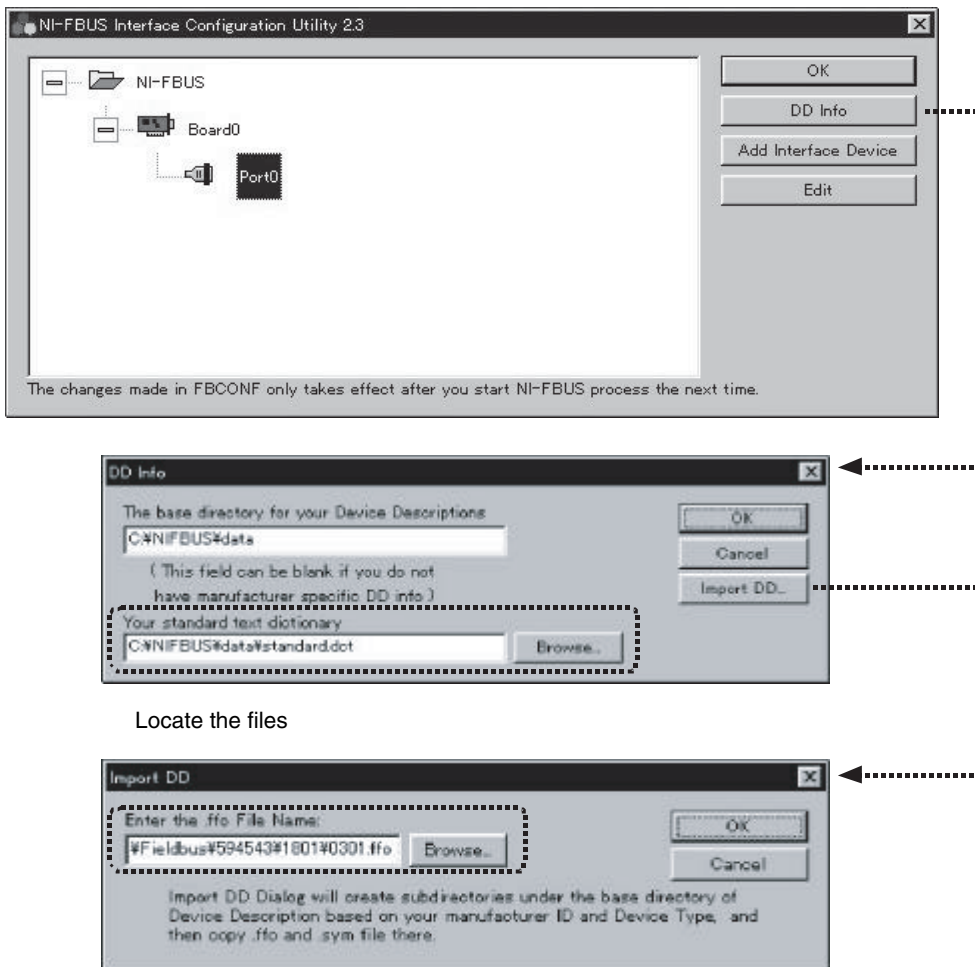

Figure 15. Import of DD

Via the Import DD dialog box, the following two kinds of files are installed in the NI-FBUS environment.

Table 9. File Imported via Import DD Dialog Box

File	Description
Dictionary file (*.dct)	Contains the text describing block profiles and help. The standard dictionary file is issued by Fieldbus FOUNDATION under the name of standard.dct. Note: Since the default dictionary provided with NI-FBUS as standard (nifb.dct) does not include information of MAI or MAO, it is recommended to obtain the most recent version of standard.dct. from Fieldbus FOUNDATION and replace nifb.dct with it.
Device description file (*.ffo, *.sym)	Contains block parameters and a view list that describes a particular device model; supplied from the vendor for each device model. Note: The DD files for a DAQSTATION are included in the standard software CD-ROM that comes with the DAQSTATION.

The original DD files can be removed after the new files are imported since Interface Configuration Utility creates copies in the NI-FBUS environment; however, do not move the dictionary files after making settings since Interface Configuration Utility does not make copies but references the original files whenever necessary.⁶

Settings to be made for stack configuration include whether to use the interface card as a link master (LM) or basic device and the transmission capabilities to be provided as an LM or basic device.

If no port is displayed in the NI-FBUS Interface Configuration Utility dialog box (top of Figure 15), it is possible that the computer has not recognized the card. In this case, double-click **System** in Control Panel, click the **Device Manager** tab in the System Properties dialog box, select **Fieldbus Adapter**, and then check whether the fieldbus interface is conflicting with other devices.⁷

6: You can make a copy of a dictionary file and set it to be referenced by Interface Configuration Utility.

7: Depending on whether an ISA or PCMCIA card is used for the fieldbus interface card, the names and locations of displayed items vary.)

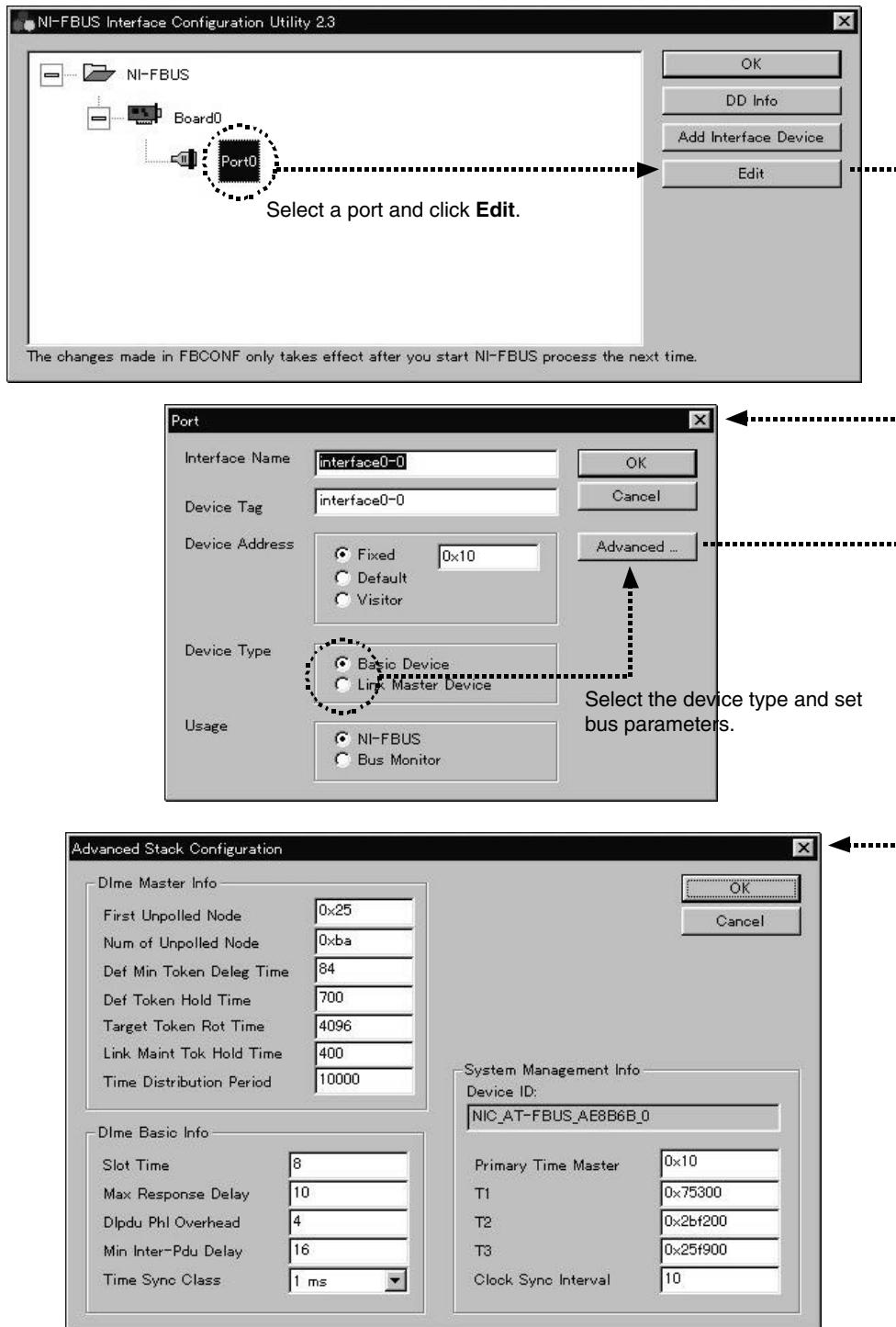

Figure 16. Setting Stack Configuration⁸

8: The settings shown in this figure are just examples and must be determined and adjusted in accordance with the purpose and usage of the card.

3.1.2 NI-FBUS Interface Driver

Running NI-FBUS interface driver causes the dialog box shown in the figure below to appear. Then, the driver goes through several states and finally falls into the running state. Nonetheless, when the interface card is not correctly recognized by the computer or stack settings are not proper, the state transition cannot advance to running and stops at a waiting state.⁹

9: To run an application using NI-FBUS, the NI-FBUS interface driver needs to be in the running state.

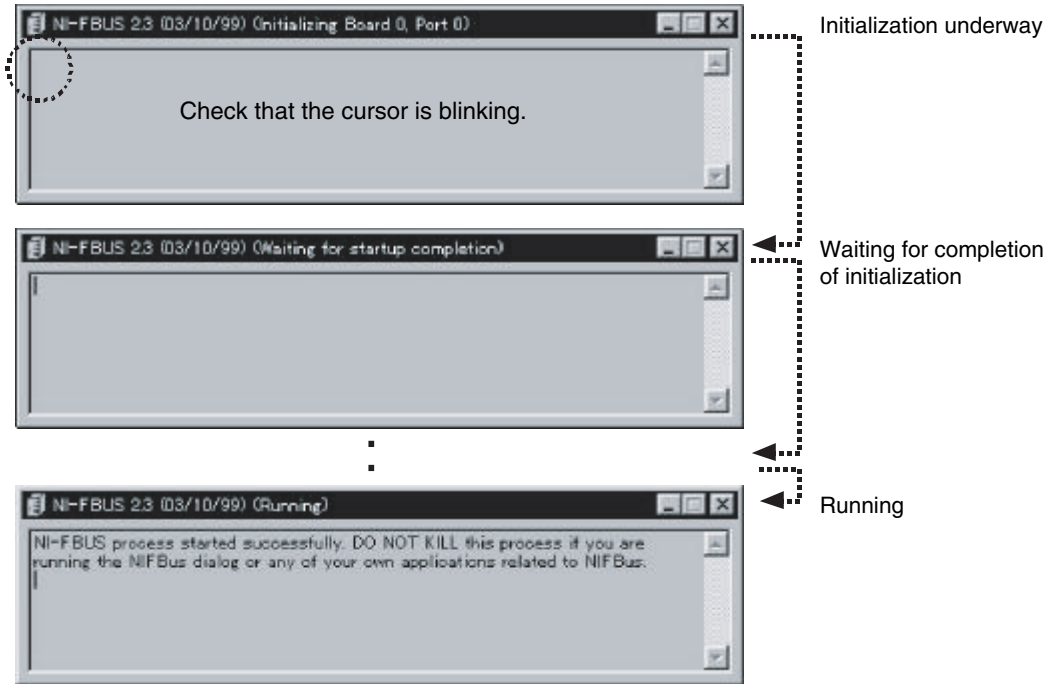

Figure 17. State Transition of NI-FBUS Interface Driver

When the beam cursor stops blinking during transition, the NI-FBUS interface driver may have stopped responding. Check the program status using Task Manager, and if "Not Responding" is shown, abort the program.¹⁰

10: This may occur when the interface card conflicts with another device or when there is a problem of compatibility between the computer and card.

3.1.3 NI-FBUS Configurator

After the NI-FBUS interface driver successfully enters the running state, click Start and choose **Programs, Nifbus, then NI-FBUS Configurator** to open the window as shown below. Then, confirm that the names of devices on the fieldbus segment, **DAQSTATION** and **EJA** in this example, are displayed in the left pane of the window.

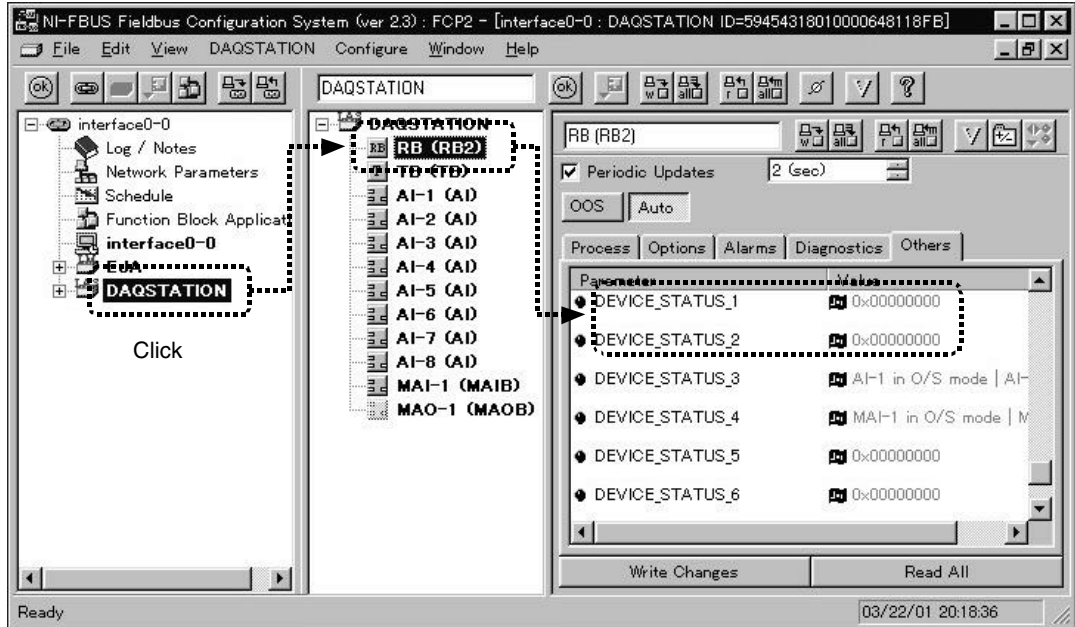

Figure 18. NI-FBUS Fieldbus Configuration System Window

Also, to confirm correct operation of the DAQSTATION's fieldbus functionality, check that the values of the parameters **DEVICE_STATUS_1** and **DEVICE_STATUS_2** in **RB** (resource block) inside **DAQSTATION** are zeros (see the figure above).¹¹

11: If a problem in the fieldbus functionality of the DAQSTATION is detected, a nonzero value representing an error is set in these parameters.

3.2 Making Settings

The figure and table below show the flow of settings for displaying the primary process value of the transmitter on the DAQSTATION's screen, namely, for delivering the OUT value of the AI block in the EJA to a display register inside the DAQSTATION. The following details each step of this setting procedure.

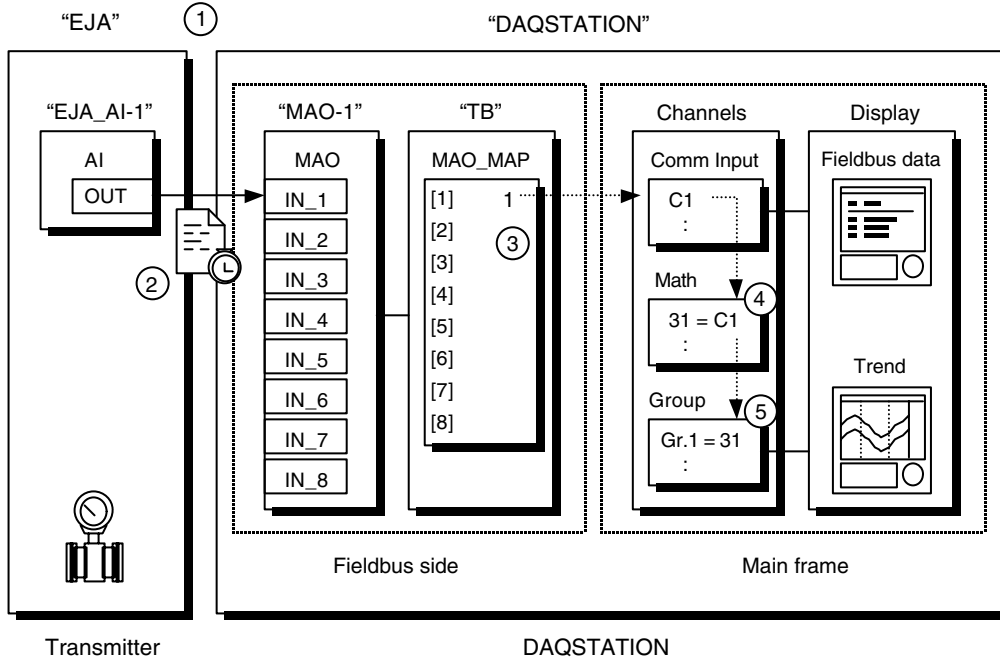

Figure 19. Flow of Setting

Table 10. Flow of Setting

Step	Items	Details
1	Setting tags and addresses	Setting the PD tag, node addresses, and block tags
2	Creating link and schedule, and downloading configuration	Creating and downloading the link between function blocks and the schedule of the function block executions and data transmission
3 to 5	Mapping	Passing the input value of MAO-1 through a communication input and mathematical calculation channel to the group settings to display it on the screen

3.2.1 Setting Tags and Addresses

To each device on a fieldbus, a PD tag and node address unique within the segment must be assigned. Also, a block tag unique within the segment must be assigned to each function block.

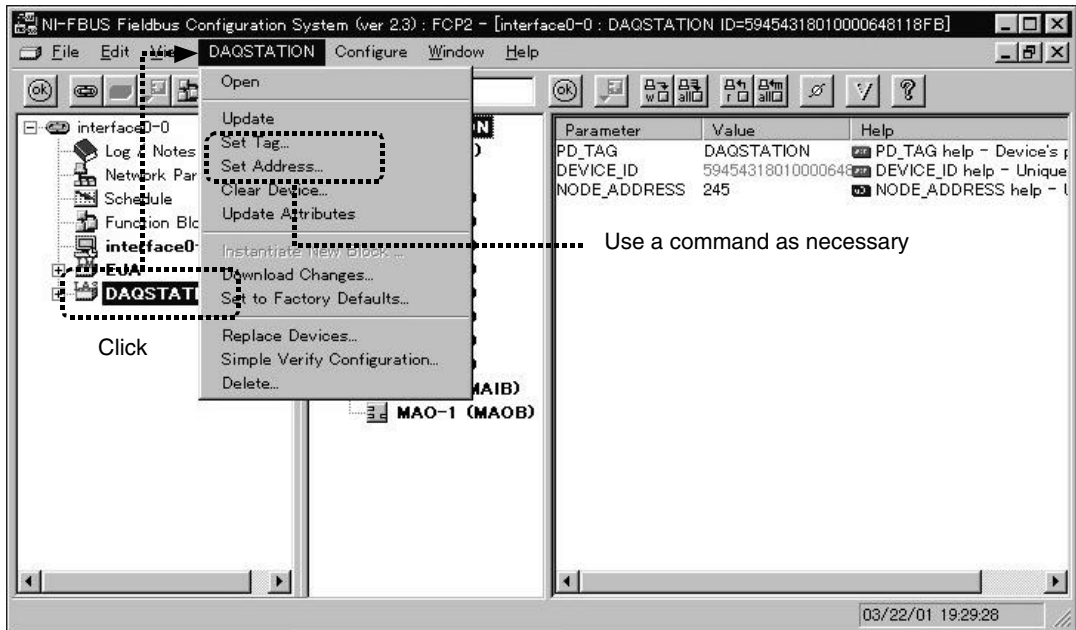

Figure 20. Setting Tags and Addresses

In the left pane of the NI-FBUS Fieldbus Configuration System window, click a device (**DAQSTATION** in this example) to bring the **PD_TAG** and **NODE_ADDRESS** values into the right pane. As necessary, use the **Set Tag** and **Set Address** commands in the **DAQSTATION** menu to change the PD tag and node address settings. You cannot set a tag or address that has already been assigned to another device. Unless all devices have a unique address and PD tag, an error will result when downloading the configuration in a later step.

3.2.2 Creating Link

To pass the primary process value output from the EJA transmitter to an input of the DAQSTATION, you need to connect a function block in the EJA to a function block in the DAQSTATION (in particular, to connect OUT of EJA_AI-1 to IN_1 of MAO-1) using a link object.

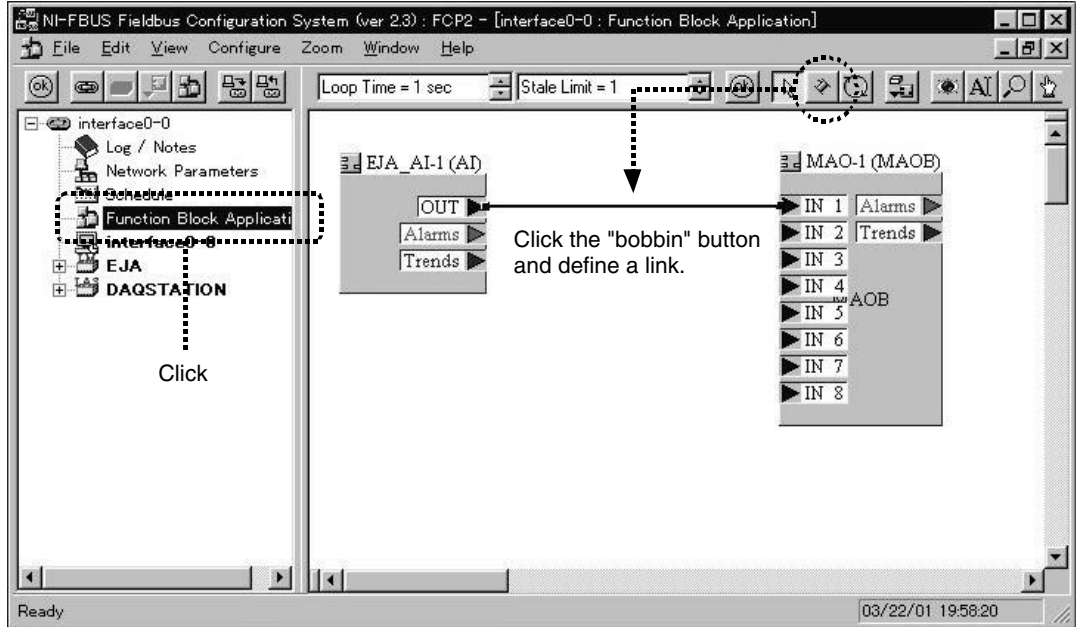

Figure 21. Creating a Link between Function Blocks

Click **Function Block Application** in the left pane of the NI-FBUS Fieldbus Configuration System window to show the EJA_AI-1 (the AI block of the EJA) and MAO-1 of DAQSTATION in the right pane. Then, connect **OUT** of EJA_AI-1 to **IN_1** of MAO-1.

As necessary, adjust the **LoopTime** (communication cycle) and **Stale Limit** (defect detection time) settings on the toolbar.¹²

12: It is recommended to set 2 or a larger value for **Stale Limit** to prevent state transitions hypersensitive to an abnormality.

3.2.3 Scheduling Function Block Execution Times and Data Transmission

After creating the link between function blocks, you need to schedule execution times of those function blocks and the data transmission over the link.

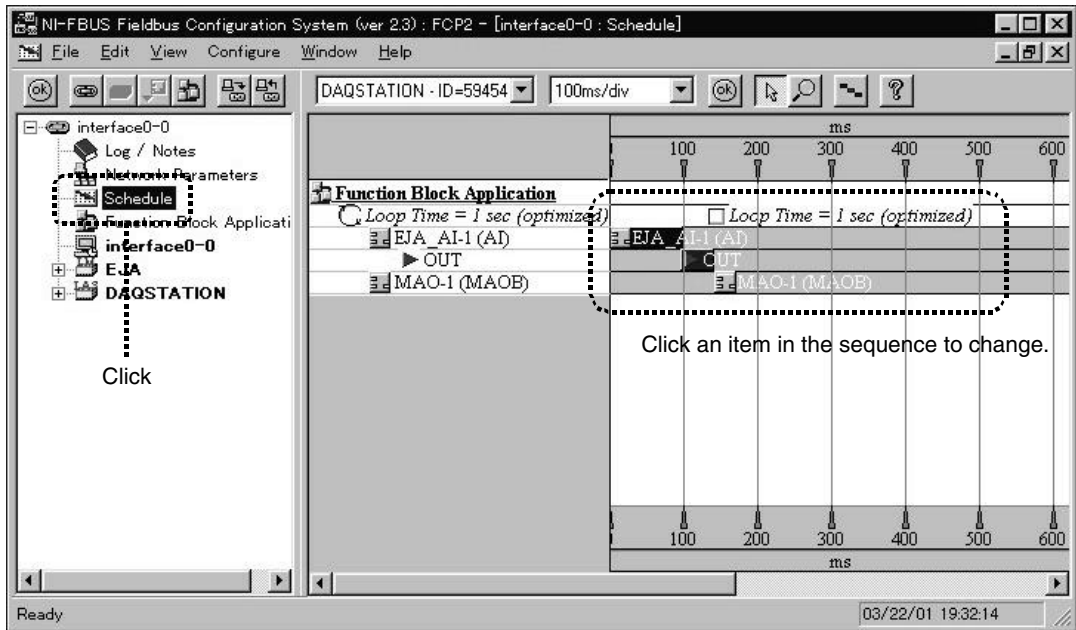

Figure 22. Scheduling Function Block Execution Times and Data Transmission

When you create a link between function blocks as in the preceding step, NI-FBUS Configurator automatically make an appropriate schedule as shown in the figure above; however, click **Schedule** in the left pane of the window and check the set sequence shown in the right pane.¹³

13: As necessary, you can adjust the function block execution times and data transmission time.

3.2.4 Downloading Configuration

After linking function blocks to each other and creating the schedule, download those settings to the devices, i.e., write them to the devices.

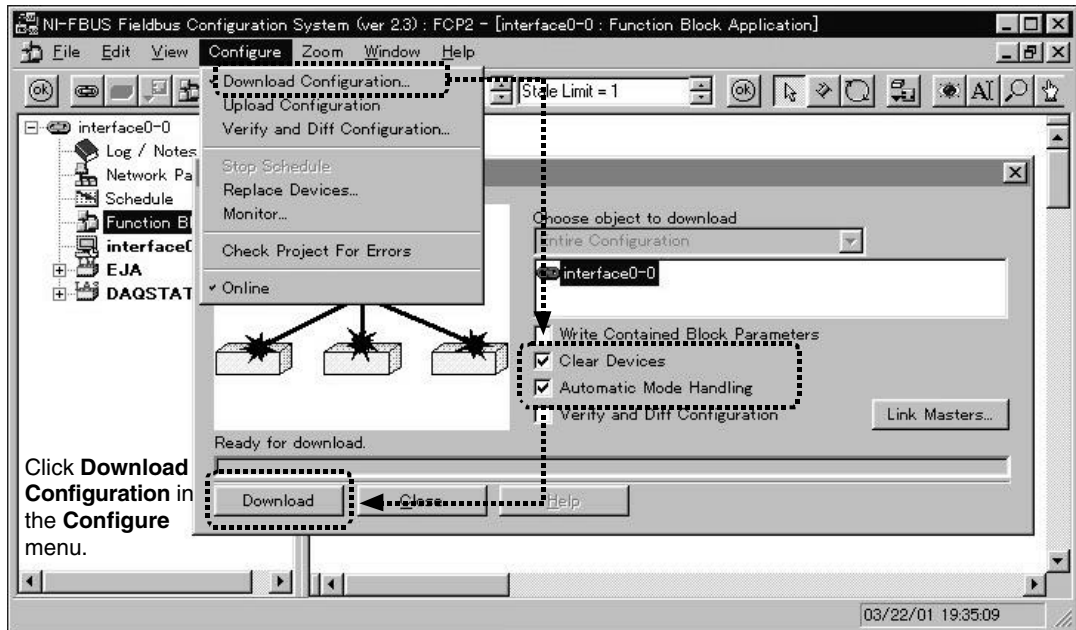

Figure 23. Downloading Configuration

Click **Function Block Application** in the left pane of the NI-FBUS Fieldbus Configuration System window and click **Configure**, then **Download Configuration** to start a download.¹⁴ When the configuration has finished being downloaded, the fieldbus communications start. Open the Monitor dialog box (see Page 3-17) and check that the primary process value of the transmitter is transmitted to the DAQSTATION.

- 14: In the Download dialog box:
- When overwriting the existing schedule with a new one, select the Clear Devices check box to clear the existing link settings.
 - Select the Automatic Mode Handling check box when you want NI-FBUS Configurator not to check mode transitions in the course of the download.

3.2.5 Mapping

To get a DAQSTATION to record and display the primary process values that exist on the fieldbus and are linked to its MAO block, you need to map the values input to IN_1 to IN_8 of the MAO to display groups via the MAO_MAP, communication channels, and mathematical calculation channels so as to show those values to the DAQSTATION's screen.

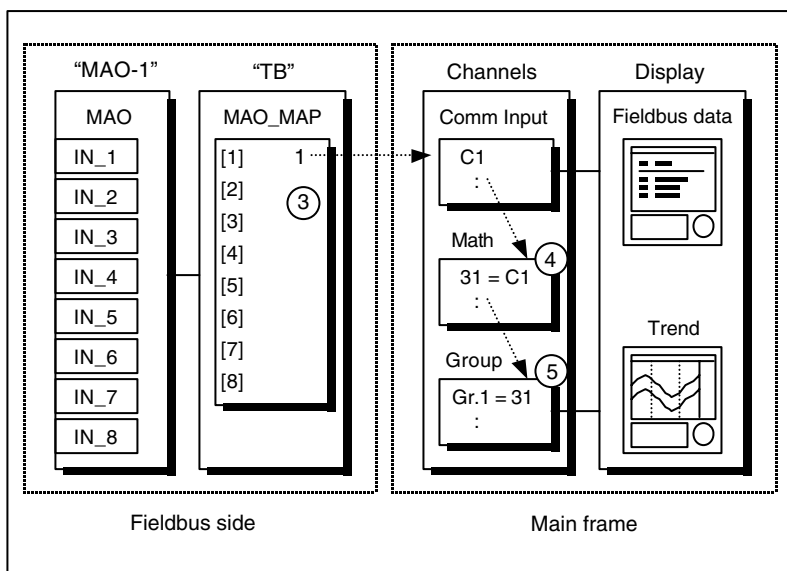

Figure 24. Flow of Mapping

Table 11. Flow of Mapping

Step	Outline	Details
3	Mapping MAO's inputs to communication channels	Mapping the values of IN_1 to IN_8 of the MAO to communication channels of the DAQSTATION's main frame via the TB block
4	Mapping communication channels to mathematical calculation channels	Using calculation expressions, putting the communication channel values in mathematical calculation channels
5	Mapping mathematical calculation channels to display groups	Assigning the calculation results of mathematical calculation channels to the display groups so as to display them on the DAQSTATION's screen

■ Mapping MAO's Inputs to Communication Channels

In a DAQSTATION, the real-value data transmitted via communications such as Ethernet and fieldbus are to be stored in communication channels (C1, C2,...) and passed to mathematical calculation channels. The mapping of the values of the MAO's inputs (IN_1 to IN_8) to communication channels is set in parameter MAO_MAP inside the TB block.

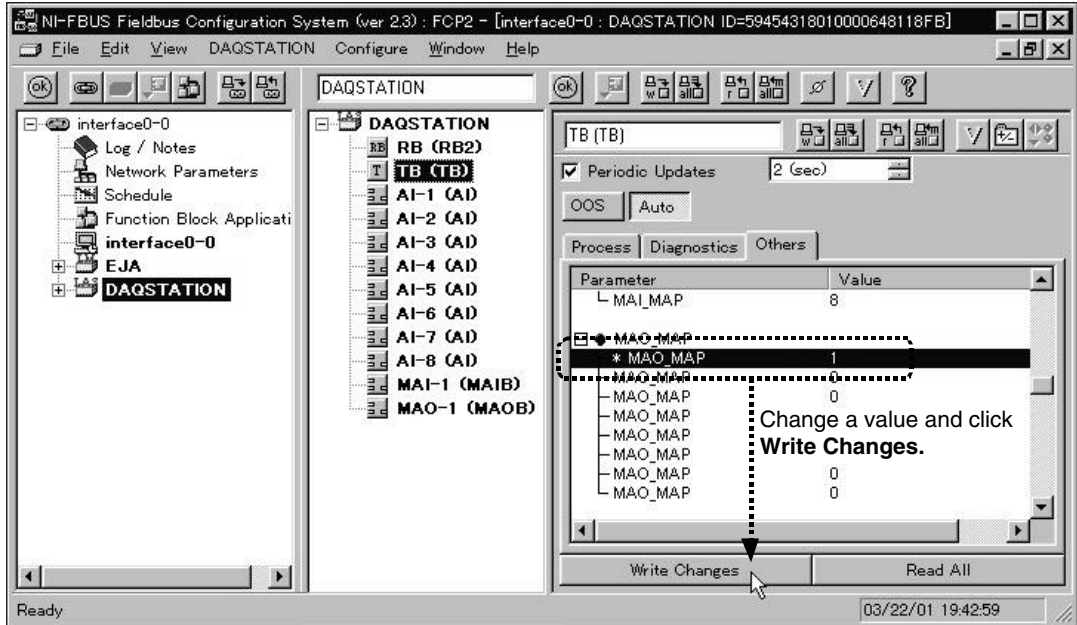

Figure 25. Mapping MAO's Inputs to Communication Channels

The first to eighth array elements in MAO_MAP store the values transmitted to IN_1 to IN_8 of the MAO, respectively. In each array element, set the desired communication channel number excluding the character "C". For example, when you want to map the IN_1 value of the MAO to communication channel C1, set 1 in the first array element of MAO_MAP.¹⁵

15: When not storing any values of MAO's IN_1 to IN_8 to a communication channel, set 0 in the respective array elements of MAO_MAP.

■ Mapping Communication Channels to Mathematical Calculation Channels

Using a calculation expression, put the value that is stored in a communication channel, in a mathematical calculation channel (C31, C32,...).

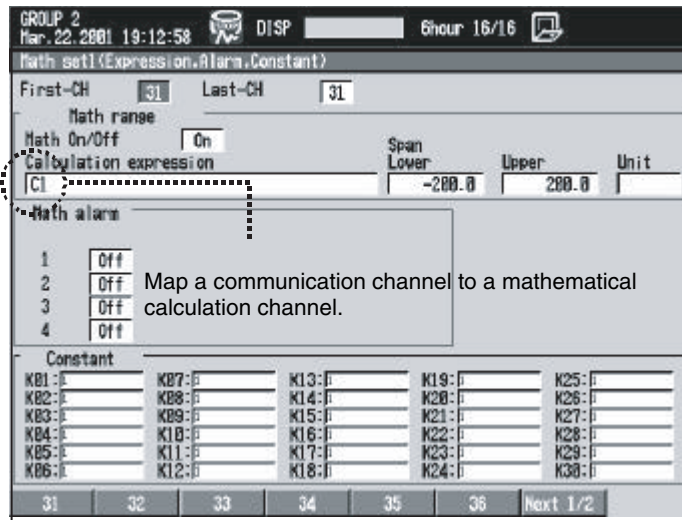

Figure 26. Mapping a Communication Channel to a Mathematical Calculation Channel

On the DAQSTATION hardware, press the Menu key, then the **Math Set1** key to retrieve the screen for setting the calculation in a mathematical calculation channel, shown above. For **Calculation expression**, set an expression so as to put the desired communication channel value in the desired mathematical calculation channel. For example, setting C1 for **Calculation expression** for channel 31 means to put the value of communication channel C1 in channel 31.¹⁶

- 16: Simply setting a calculation expression does not start carrying out the calculation. To start the calculation, do either of the following:
 - Press the Func key, then the **Start Math** key.
 - Press the START key.

■ Mapping Mathematical Calculation Channels to Display Groups

To display on the DAQSTATION's screen a value calculated in a mathematical calculation channel, you need to add the mathematical calculation channel to one of display groups 1 to 4.

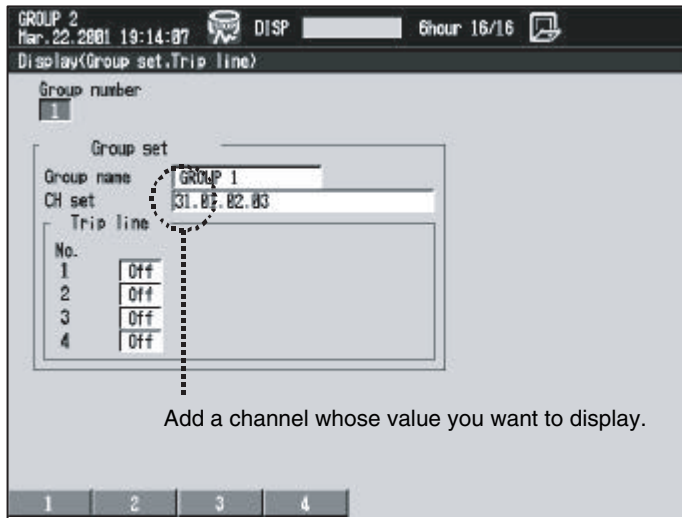

Figure 27. Adding Mathematical Calculation Channel to a Display Group

On the DAQSTATION hardware, press the Menu key, **Display**, then **Group set** to retrieve the screen for setting the display groups, shown above. Select the desired group in **Group name** and add the desired mathematical calculation channel to **CH set**

This completes the setting. If the settings have been correctly made, pressing the START key on the DAQSTATION hardware starts the specified calculation in the mathematical calculation channel and causes the primary process value of the transmitter to start being displayed and recorded.

3.3 Checking Operation

The following shows you how to check whether the DAQSTATION's fieldbus functionality is working as intended by the settings. After completing the settings in Section 3.2, check the following in order.¹⁷

17: Note that the checks introduced in this section are necessary but not sufficient for verification of correct operation.

3.3.1 Monitoring Transmissions

You can monitor the data transmission statuses using the monitoring function of NI-FBUS Configurator.

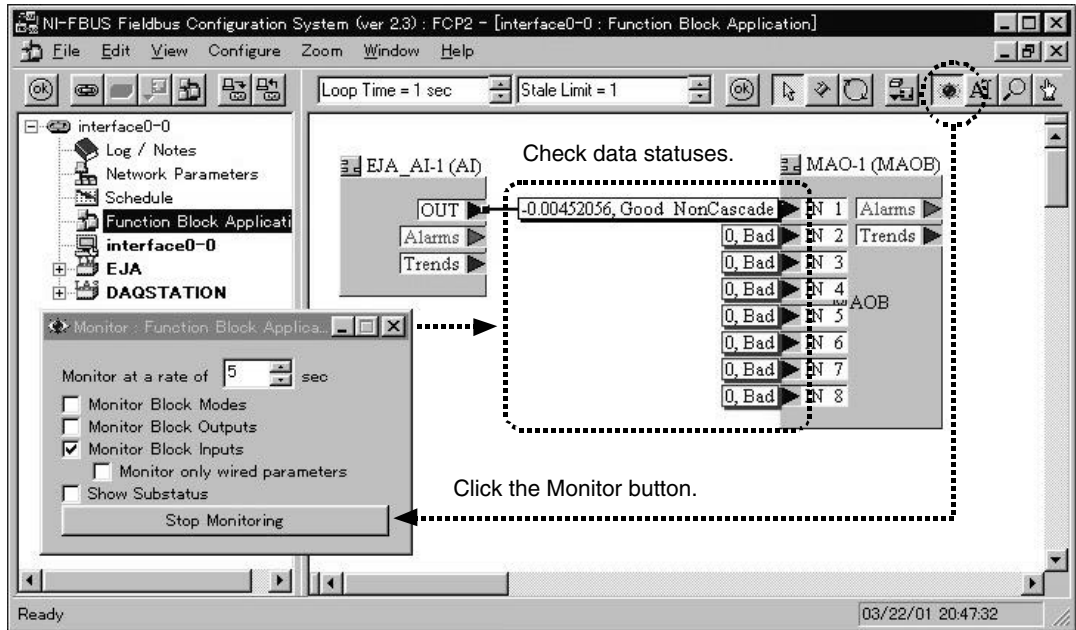

Figure 28. Monitoring Data Transmissions from a Function Block to Another

Click **Function Block Application** in the left pane of the NI-FBUS Fieldbus Configuration System window and click **Configure**, then **Monitor**, or click the Monitor button on the toolbar. The Monitor dialog as shown above appears. Click **Start Monitoring** in the Monitor dialog box to start showing the current statuses and values, and check the statuses and values of OUT and IN_1, the start and end points of transmission.

3.3.2 Checking Displayed Data

On the DAQSTATION's screen, check the status and value of the primary process value input to the MAO block in the DAQSTATION.

■ Checking Trend Graph

Retrieve on the screen the trend graph of the group to which the primary process value input to the MAO block is mapped, and check that it is correctly plotted.

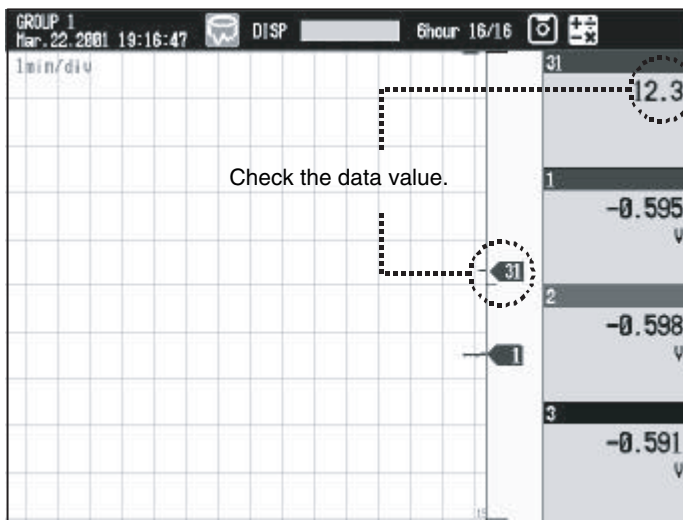

Figure 29. Checking Data Value on Trend Display

■ Checking Fieldbus Data Display

On the DAQSTATION, press the Func key, then Fieldbus to retrieve the fieldbus data display on the screen. Then, check the PD tag and node address set for the DAQSTATION itself being a fieldbus device, and the data statuses of the values set in the input channels.

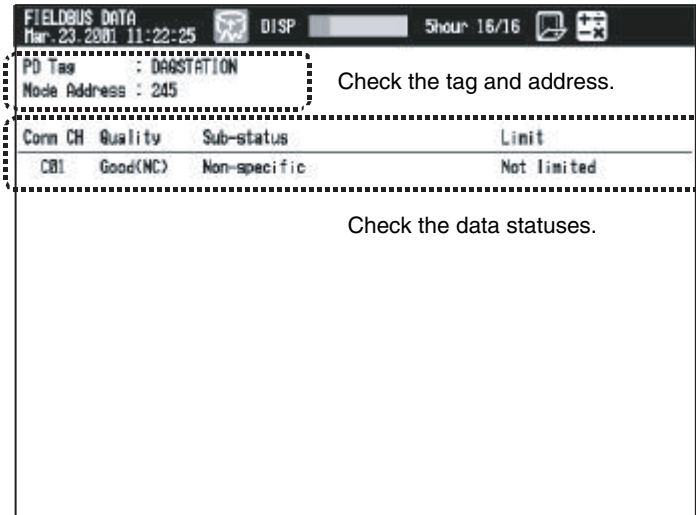

Figure 30. Checking Fieldbus Data

Blank Page

4. Example of Setting (CENTUM FIELDBUS ENGINEERING TOOL)

As an example of setting a fieldbus system with a DAQSTATION, the following introduces the procedure using a configurator of CENTUM FIELDBUS ENGINEERING TOOL to create a simple application to display the primary process value of a transmitter on the DAQSTATION's screen.

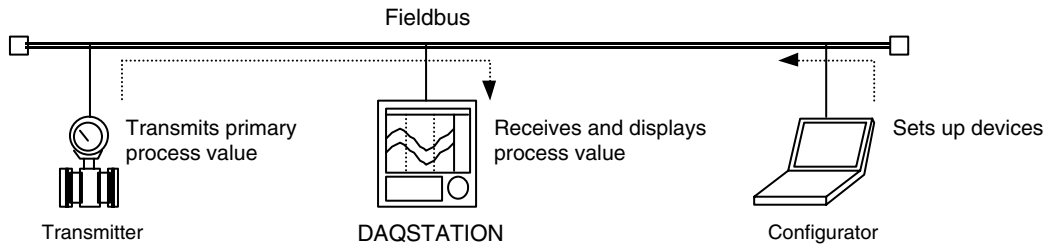

Figure 31. Creating a Simple Application

The table lists equipment used to create this application. Albeit an EJA is listed as the transmitter, a different transmitter model can be used absolutely. Although no specifications are given for the wiring hardware such as the fieldbus cable, power supply, or terminators, use the hardware compliant to the FOUNDATION Fieldbus specifications.

Table 12. Equipment Needed to Create the Example Application

Name	Model
Interface driver	NI Model code: 777282-01
Configurator	CENTUM FIELDBUS ENGINEERING TOOL: Fieldbus Support Tool for DAQSTATION (SSS6800-S-0, SSSSM01-0-0)
Transmitter	EJA fieldbus version 2.01
DAQSTATION	DAQSTATION fieldbus version 3.01
Wiring	H1 fieldbus cable
	Power supply (required because both the EJA and DAQSTATION need to be powered from the fieldbus).
	Terminator

4.1 Getting Started

In this section, you set the parameter of the Interface Configurator Utility (Interface Config) according to the Section 3.1.1. It is not necessary to do the Import of DD. Regarding the start-up of Interface driver. Please refer to the section 3.1.2.

4.1.1 Fieldbus Support Tool for DAQSTATION

The following describes the outline of Software composition (Fieldbus Support Tool for DAQSTATION). The details refer to IM33S5P10-01.

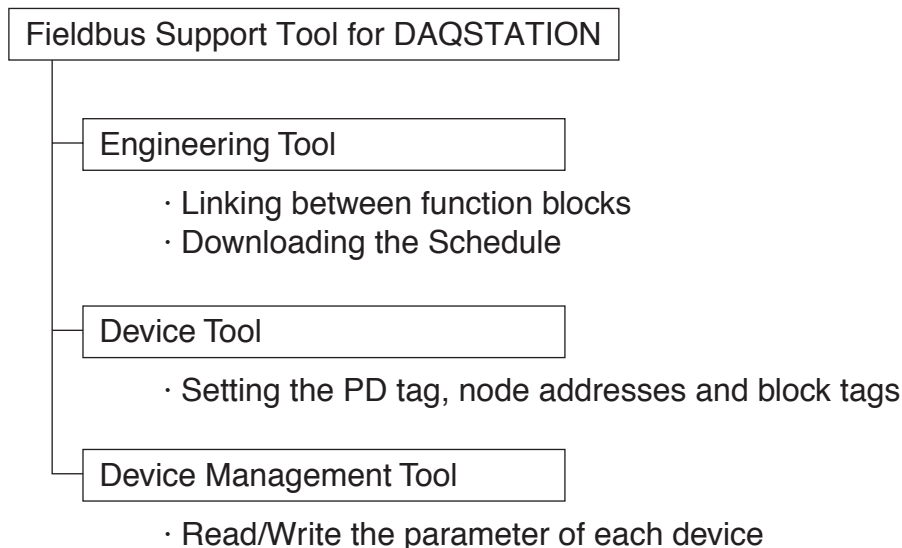

Figure 32. The outline of Software composition

4.2 Making Settings

The figure and table below show the flow for displaying the primary process value of the transmitter on the DAQSTATION's screen, namely, for delivering the OUT value of the AI block in the EJA to a display register inside the DAQSTATION. The following details each step of this setting procedure.

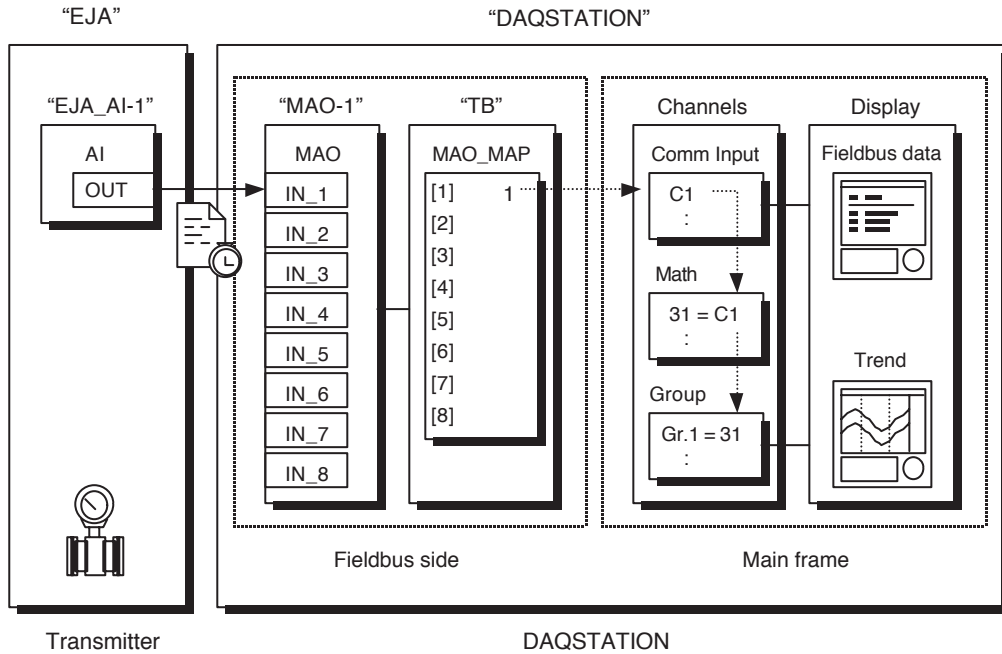

Figure 33. Flow of Process Value

Table13. Flow of Setting

Step	Items	Details
1	Initial Setting of the Fieldbus Engineering Tool	Security related settings such as user name and password, as well as settings related to communication in the control bus are performed. Also, capabilities files for the fieldbus device are imported to the Fieldbus Engineering Tool. In the case of a slave PC, settings related to control bus communication are not required.
2	Settings for the Project and Fieldbus Device	A project is created and devices are registered in the created project. Also, settings related to the network configuration of the registered devices are performed.
3, 4	Settings for FBAP	Function blocks of registered devices are combined and the FBAP (function block application process) is created. Scheduling of communication with the created FBAP function block is performed. And download the FBAP to each devices.

4.2.1 Setting Up Fieldbus Engineering Tool

■ Calling Up Project Manager

- (1) From the [Start] menu of Windows, select [Fieldbus Tool], and then [Engineering Tool].

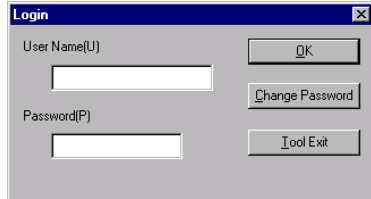

Figure 34. Login window

- (2) Input a user name and password, and click the "OK" button.

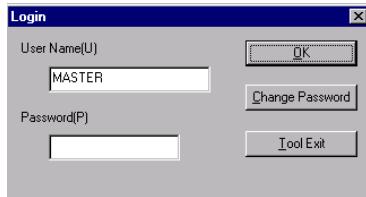

Figure 35. Input a user name

- 18: When Fieldbus Engineering Tool is installed, the default user name "MASTER" is registered automatically. With the default setting immediately after Fieldbus Engineering Tool is installed, no passwords are set for "MASTER". Therefore, if you click the "OK" button without inputting of the password, you can log-in Fieldbus Engineering Tool.
- (3) If you log-in Fieldbus Engineering Tool, the copyright dialog box will appear. Click the "OK" button.

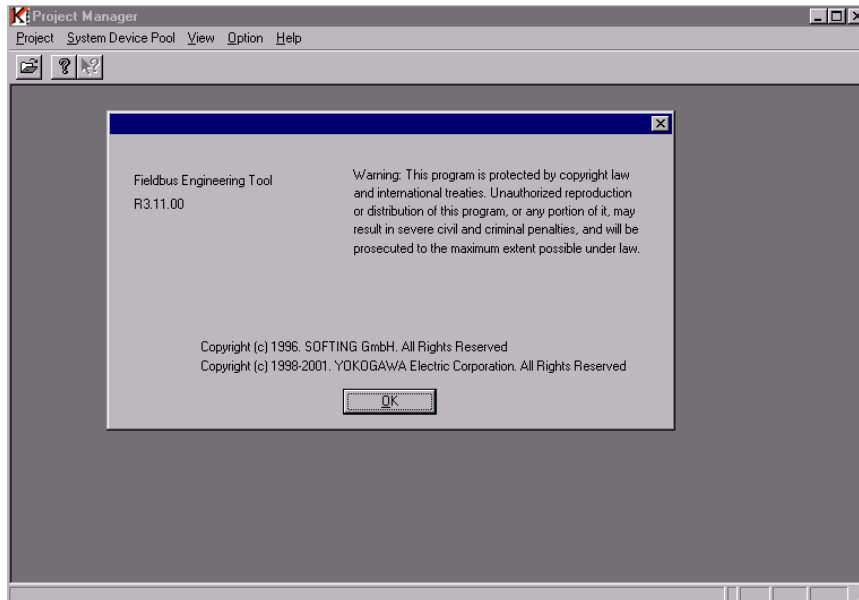

Figure 36. Copyright dialog

- (4) Fieldbus Engineering Tool is started up and Project Manager will appear.

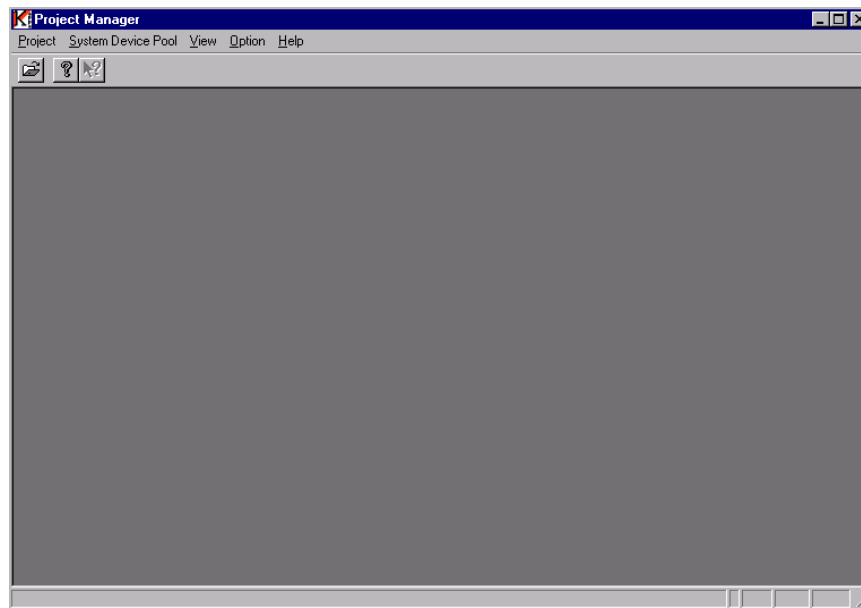

Figure 37. Project Manager

■ **Setting Up the Environment**

- (1) From the [Option] menu of Product Manager, select [Environment Settings...]. The "Environment Settings" dialog box will appear. In this dialog box, specify a directory path where the capability file and DDOD are installed.

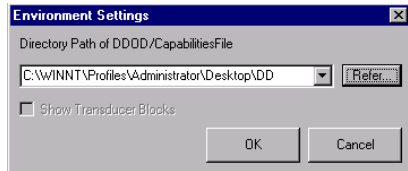

Figure 38. Environment Setting dialog

Follow the steps below to specify a directory path where the capability file and DDOD are installed.

- 1) Use either operation step to specify a directory path.
Select a directory path from the "Directory Path of DDOD/CapabilitiesFiles" combo-box. Specify a directory path in the "Directory Reference" dialog box displayed by clicking the "Refer..." button.
- 2) Click the "OK" button.
The directory path is changed and the screen is returned to Project Manager.
If you click the "Cancel" button, the directory path is not changed and the screen is returned to Project Manager.

Making the transducer block display active

- 1) Check on the "Show Transducer Blocks" check box.
- 2) Click the "OK" button.
The transducer block display becomes active and the screen is returned to Project Manager.

- 19: DDL (Device Description Language)
This is the description language for describing the device configuration elements and the specifications of that language. The DD source that is described using DDL is compiled by the software called Tokenizer and distributed as a DDOD provided by vendors of the devices.

DDOD (Device Description Object Dictionary)
This is the object file in which the DD source described using DDL has been compiled using the software called Tokenizer. Specifications for the device function resources are described in the DD source.

■ Setting Up System Device Pool

Follow the steps below to import the capability file and DDOD to the system database.

- (1) From the [System Device Pool (S)] menu of Project Manager, select [Show (S)...]. The "System Device Pool" dialog box will appear.

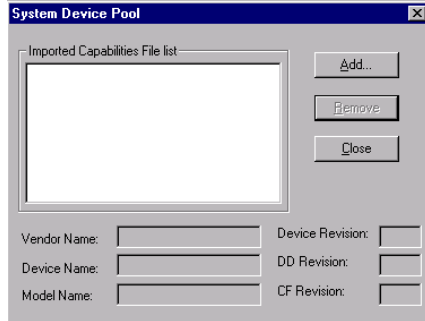

Figure 39. System Device Pool dialog

- 20: Import
Import means to import a configuration data file that has been described in a format that follows the Common File Format, to the project database from external media.

- (2) Click the "Add" button.
The "Capabilities File Selection" dialog box will appear. In the tree view shown on the left of the screen, manufacturer IDs and device types are displayed hierarchically.

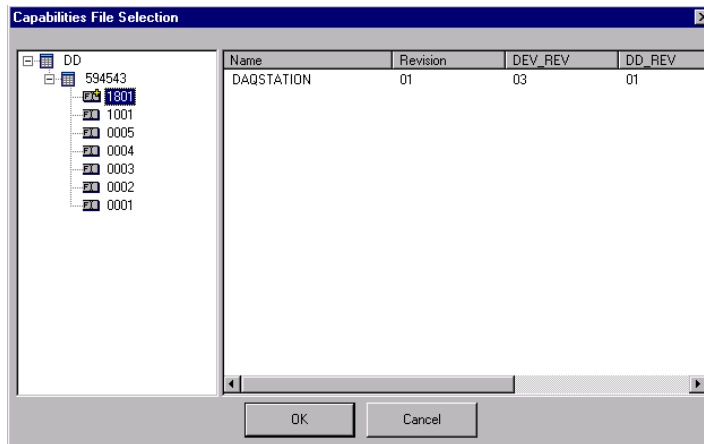

Figure 40. Capabilities File Selection dialog

- (3) Select a device type in the tree view.
The information about each capability file, such as name (device name), revision information, file date, and file type, is displayed in the list view on the right of the screen.

- (4) In this list view, select a capability file you wish to import.

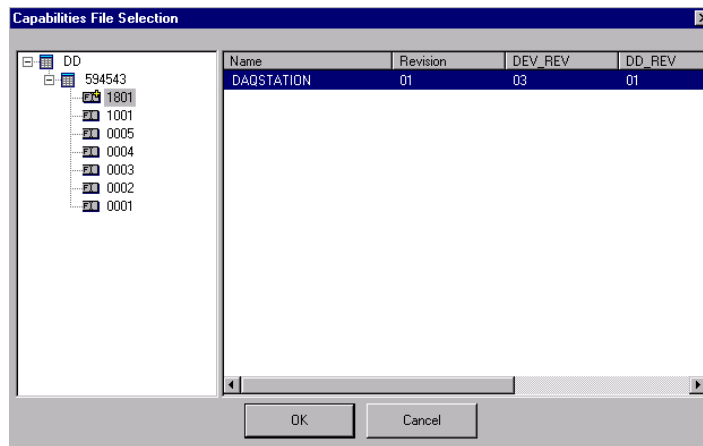

Figure 41. Select DAQSTATION

- (4) If import finish, DAQSTATION will appear in the System Device Pool.

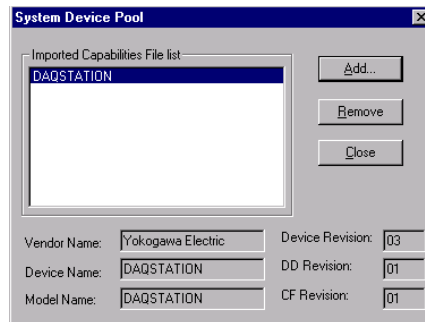

Figure 42. Import DAQSTATION

- (4) Follow steps (2) to (4) to select EJA (Device type: 0003, Model type: EJA100A). If import finish, EJA will appear in the System Device Pool.

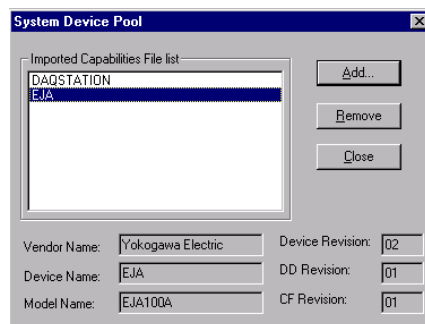

Figure 43. Import EJA

4.2.2 Setting Up the Project and Fieldbus Device

■ Creating a New Project

The Fieldbus Engineering Tool controls the devices connected to one segment of the fieldbus by project.

- (1) From the [Project (P)] menu of Product Manager, select [New (N)...]. The "Open" dialog box will appear.

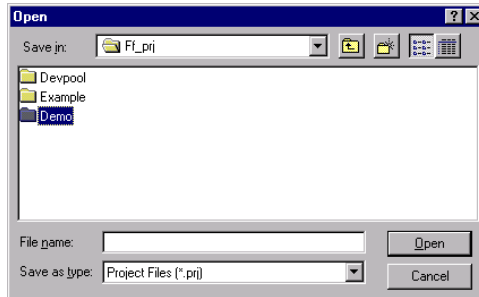

Figure 44. Open dialog

- (2) Create a directory (Demo), in which you wish to make a project.
- (3) Input the project file name (interface0-0) of a project you wish to create in the "File name" box and click the "Save" button. A newly input project is created. The project database for saving of various settings related to the project is also created. Additionally, all the capability files imported to the system database are also copied to the project database.

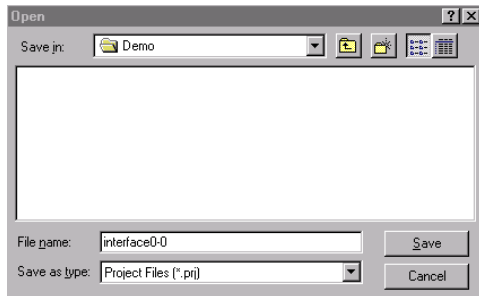

Figure 45. Create the project file

- (4) When a new project is created completely, the information about the project will be shown on Project Manager.

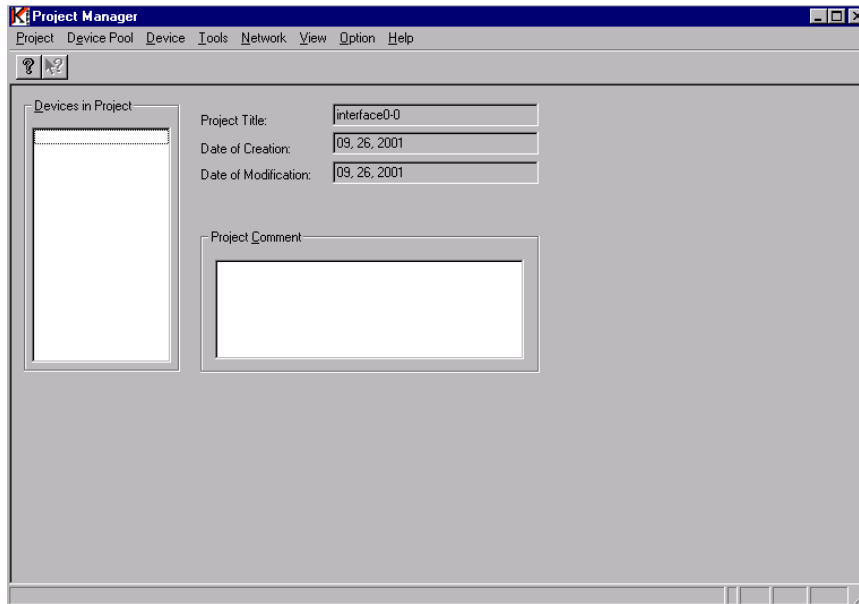

Figure 46. Project Manager

■ Calling Up the Device Editor

You may call up the device editor. With the device editor, you may register devices into the project and set up the configuration data of the registered device.

- (1) From the [Tool (T)] menu of Project Manager, select [Device Editor (D)]. The device editor will be called up.

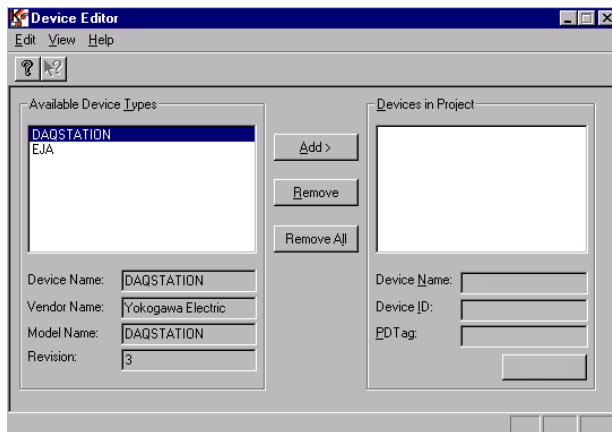

Figure 47. Device Editor

The device editor provides two group boxes, "Available Device Types" and "Devices in Project". The "Available Device Types" group box shows the information necessary to select a device to be registered into the project. The "Available Device Types" group box shows the information about the configuration of the device registered in the project.

The following describes the information shown in the "Available Device Types" and "Devices in Project" group boxes.

■ Registering a Device to the Project

FBAP is created by combining function blocks built-into the device. To use the function blocks of the device, you may register a device into the project.

At this time, you can register only a device, the capability file of which has been imported to the project database.

- (1) From the "Available Device Types" list box of the device editor, select DAQSTATION you wish to register.
- (2) Click the "Add" button. The "New Device" dialog box will appear. At this time, a text string, to which a serial number registered in the device type is added, is shown in the "Device ID" and "PDTag" boxes as default value.

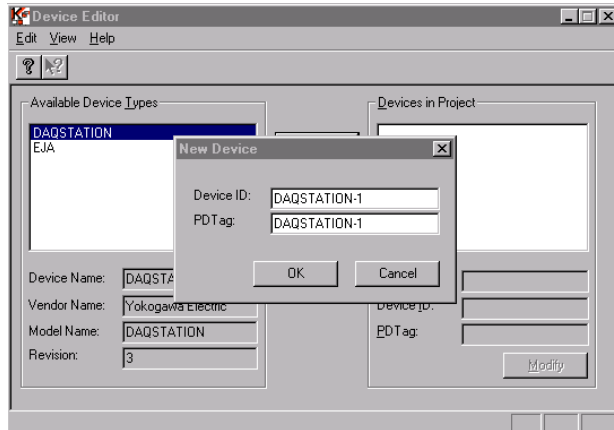

Figure 48. Register DAQSTATION

- (3) Click the "OK" button.
- (4) Follow steps (1) to (3) to register EJA.
- (5) The "New Device" dialog box will be closed and the physical device tag name of the device you have added is shown in the "Devices in Project" list box.

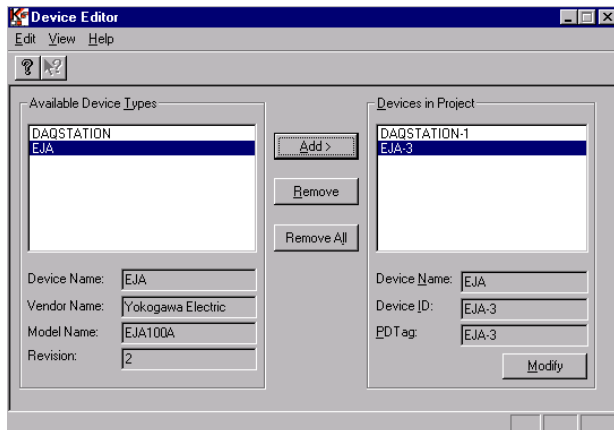

Figure 49. Register EJA

- (6) When a device is registered into the project completely, the information about the project will be shown on Project Manager.

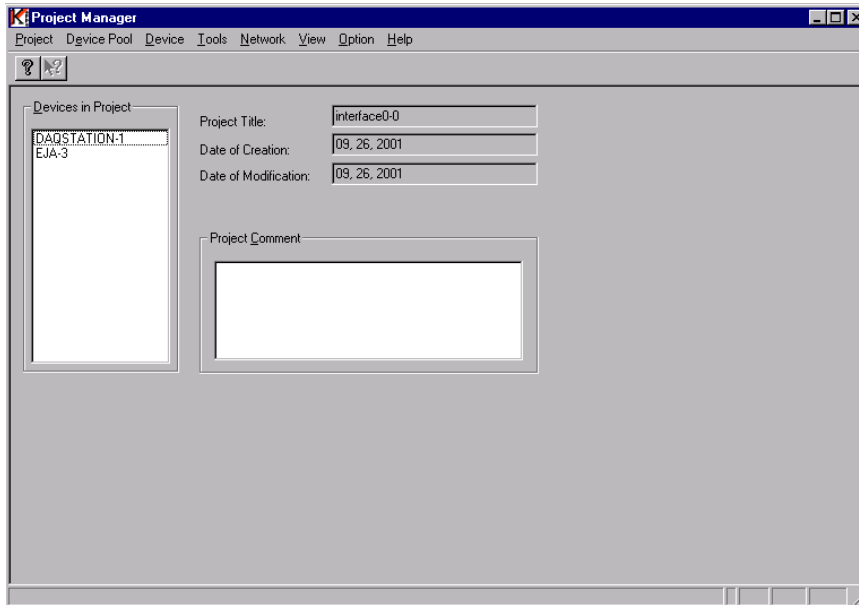

Figure 50. Project Manager

■ Operating the Device List

The device list of the "Fieldbus Device Tool" window shows various kinds of information about field bus devices connected to the H1 field bus. The attributes of each device (device ID, physical device tag name, node address, MANUFAC_ID, DEV_TYPE, DEV_REV, and DD_REV) are shown in this list.

- (1) To show various kinds of information about field bus devices, click the "Update Device List" button. The following device list will be shown.

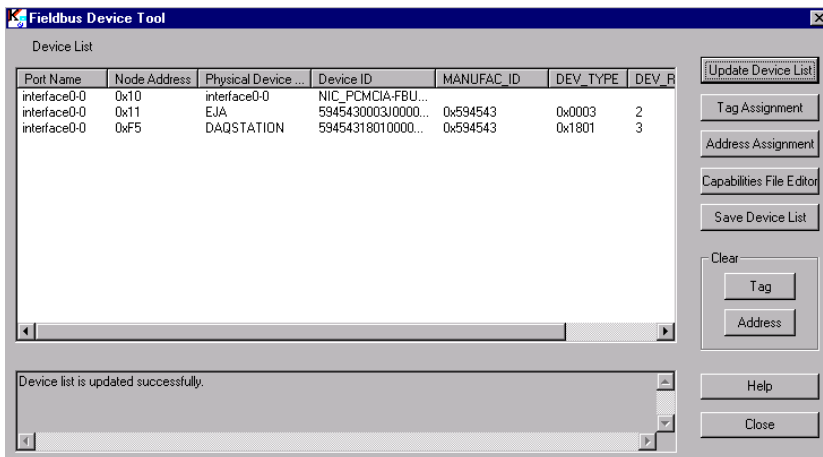

Figure 51. Device List

- (2) From the [Tool (T)] menu of Project Manager, select [Device Editor (D)]. The device editor will be shown.

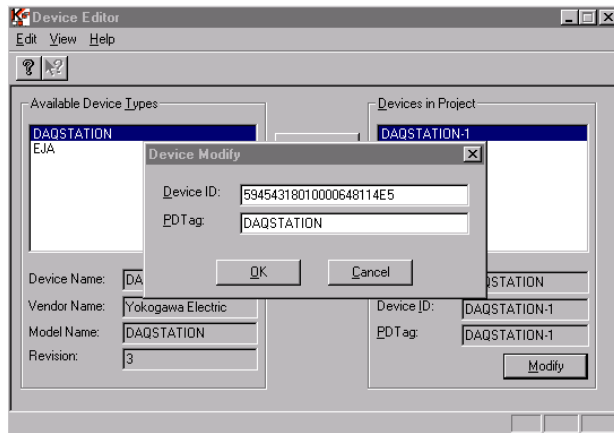

Figure 52. Device Modify (DAQSTATION)

- (3) From "Devices in Project" list box of the device editor, select the type name of a device you wish to change.
- (4) Click the "Modify" button. The "Device Modify" dialog box will appear. At this time, the device type with a serial number put, which is registered in section 3, is shown in the "Device ID" and "PDTag" boxes as default value.
- (5) From the device list displayed in step (1), read the device ID of the DAQSTATION device (DAQSTATION) and input it in the "Device ID" box.
- (6) Accordingly, input the physical device tag name of relevant device (DAQSTATION) in the "PDTag" box.
- (7) Follow steps (2) to (6) to set up EJA.

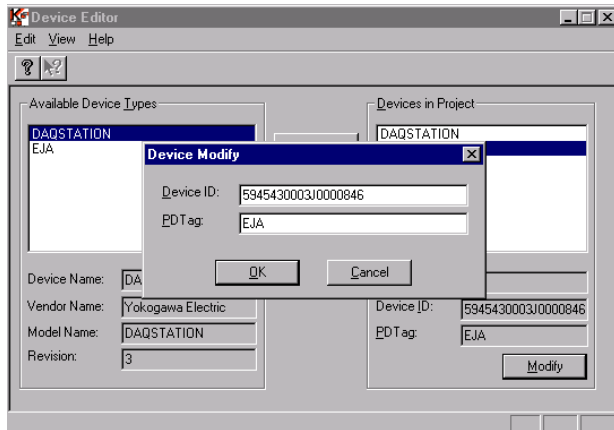

Figure 53. Device Modify (EJA)

■ Calling Up the Network Editor

With the network editor, you may set up the node address and device class for the devices registered in the project.

- (1) From the [Tool (T)] menu of Project Manager, select [Network Editor (N)]. The network editor will be called up.

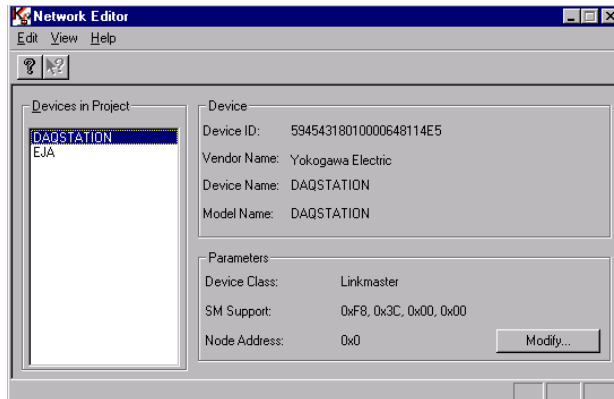

Figure 54. Network Editor dialog

The network editor provides the "Devices in Project" list box, as well as "Device" and "Parameters" group boxes.

The "Devices in Project" list box shows the list of physical device tags of devices registered in the project. The "Device" and "Parameters" group boxes show the detailed information about the device selected in the "Devices in Project" list box.

- (2) Select DAQSTATION in the "Devices in Project" list box and click the "Modify" button. The "Network Parameter" dialog box about DAQSTATION will appear.

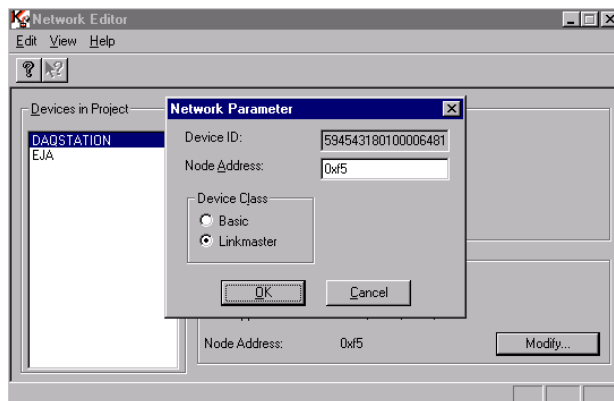

Figure 55. Modify Network Parameter (DAQSTATION)

- (3) Read the node address (DAQSTATION) of the DAQSTATION device (DAQSTATION) from the "Devices in Project" list of Fieldbus Device Tool Window and input it in the "Node Address" box.
- (4) Next, check on "Linkmaster" in "Device Class".
- (5) Click the "OK" button.
The network parameter dialog box will be closed and the network parameters you have set up are saved to the project database.

- (6) Follow steps (2) to (5) to set up EJA.
At this time, check on "Basic" in "Device Class".

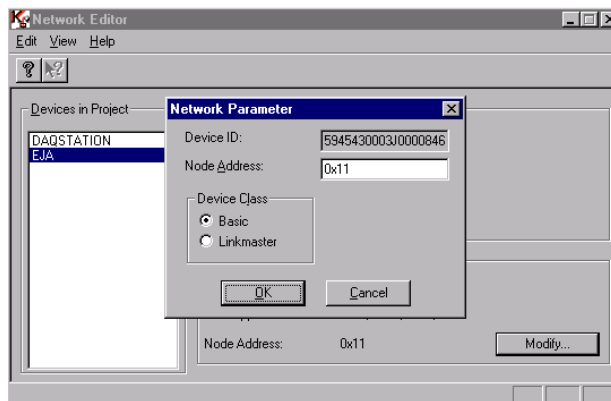

Figure 56. Modify Network Parameter (EJA)

4.2.3 Creating a FBAP Configuration Diagram

■ Calling Up the FB Editor

With the FB editor, you may create a FBAP configuration diagram.

- (1) From the [Tool (T)] menu of Project Manager, select [FB Editor (F)].
The FB editor will be called up.

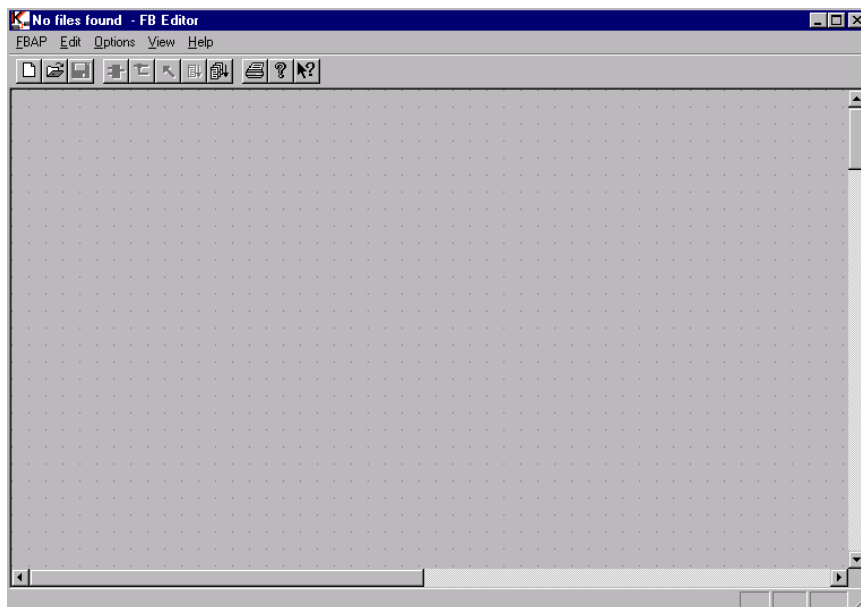

Figure 57. FB Editor

- (2) From the [FBAP] menu of the FB editor, select [New (N)...] or click the [New] icon on the toolbar.
The "New FBAP" dialog box will appear.

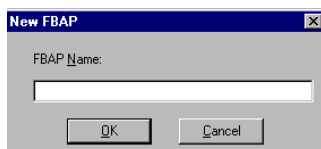

Figure 58. New FBAP dialog

- (3) Input a FBAP name (FBAP1) you wish to create newly in the [FBAP Name] box.

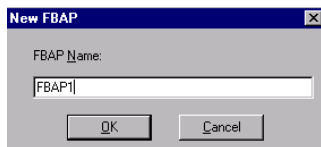

Figure 59. Input a FBAP name

- (4) Click the "OK" button.
The "New FBAP" dialog box will be closed. The drawing area is initialized and the FBAP configuration diagram name is shown on the title bar of the FB editor.

- (5) Click the "OK" button.
The "New FBAP" dialog box will be closed. The drawing area is initialized and the FBAP configuration diagram name is shown on the title bar of the FB editor.

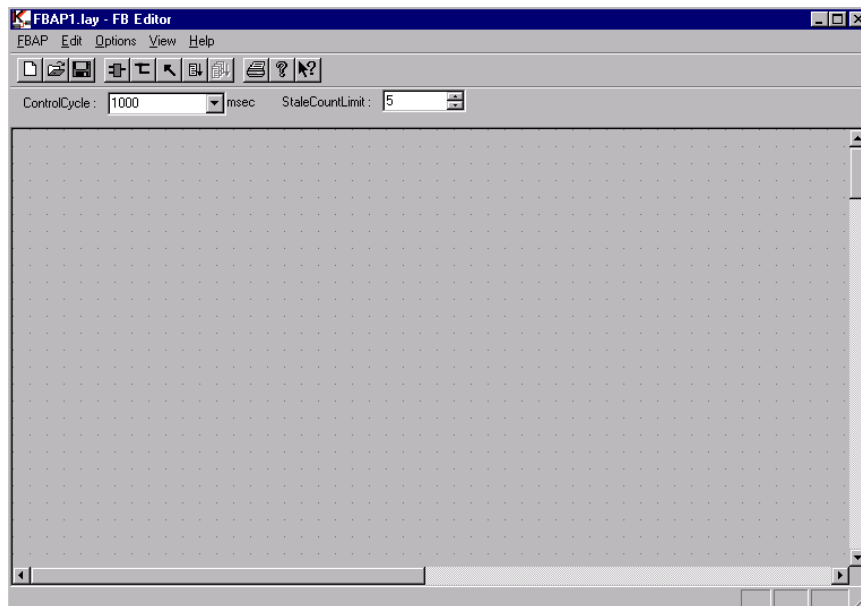

Figure 60. FBAP1 FB Editor

■ Creating a FBAP diagram

- (1) From the [Edit (E)] menu of the FB editor, select [Insert Function Blocks (I) ...]. The "FB Pool" dialog box will appear.
The "Devices in Project" list box shows the physical device tags of the devices. The "Available Function Blocks" list box shows the default block tag names of the function blocks.

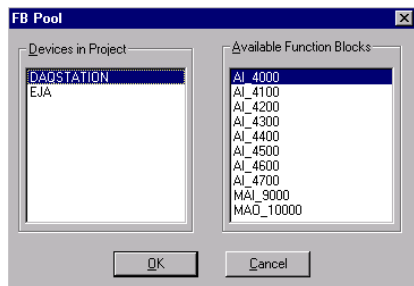

Figure 61. FB Pool dialog

- (2) From the "Devices in Project" list box, select a device (DAQSTATION) you wish to use.
The "Available Function Blocks" list box shows the list of block tag names of function blocks included in the device you have selected. Additionally, the text string "(used)" is put on the function blocks already arranged in the FBAP configuration diagram.

- (3) From the "Available Function Blocks" list box, select a MAO function block you wish to use.

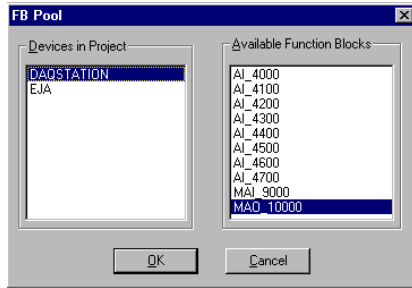

Figure 62. FB Pool dialog (DAQSTATION)

- (4) Click the "OK" button.
The "FB Pool" dialog box will be closed and the mouse cursor will be changed to the cross mark.
- (5) Click a desired position in the drawing area.
The "Function Block Name" dialog box will appear.
- (6) Click a desired position in the drawing area.
The "Function Block Name" dialog box will appear.

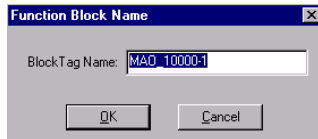

Figure 63. Function Block Name dialog

- (7) Click the "OK" button.
The function block is then registered and located at the cross cursor position in the drawing area. The block tag name is shown at the upper portion of the located function block and the physical device tag name is shown at the lower portion.

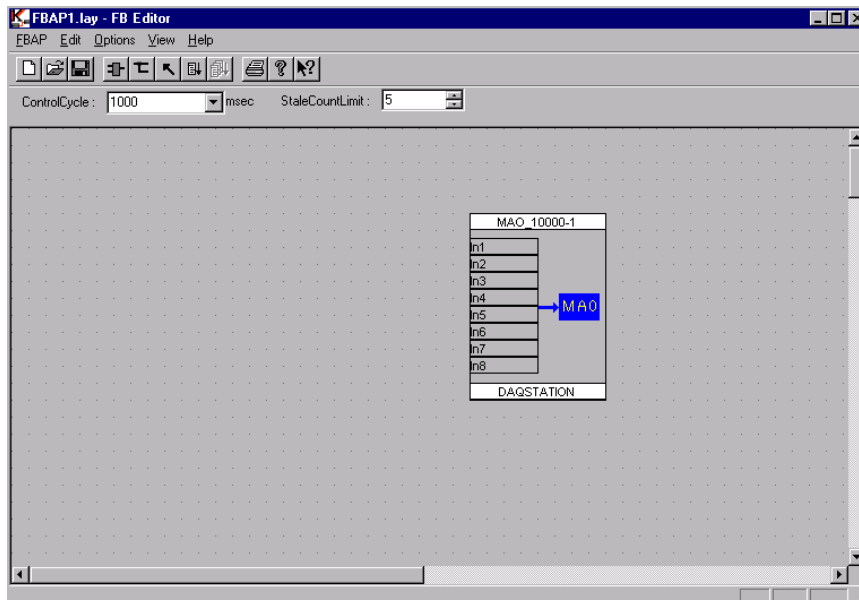

Figure 64. Locate the Function Block (DAQSTATION)

- (8) Follow steps (1) to (7) to set up EJA.
Select an AI function block you wish to use.

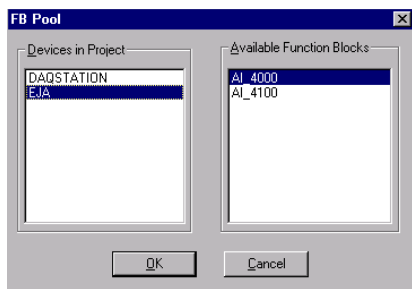

Figure 65. FB Pool (EJA)

Click a desired position in the drawing area. The following "Function Block Name" dialog box will appear.

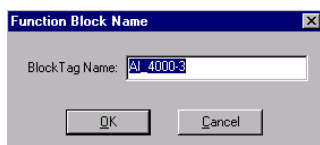

Figure 66. Function Block Name dialog

- (9) Click the "OK" button in the "Function Block Name" dialog box.
The function block is then registered and located at the cross cursor position in the drawing area.

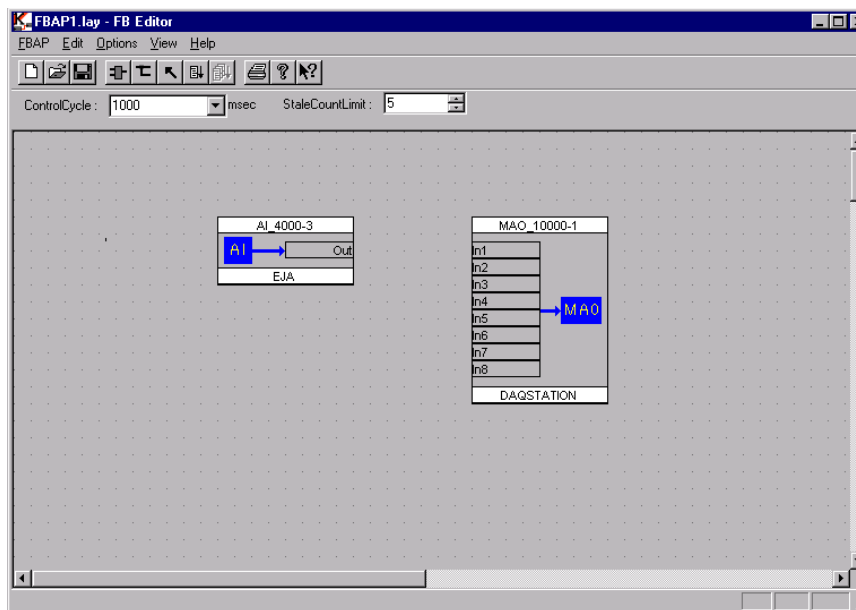

Figure 67. Locate Function Block (EJA)

- (10) From the [Edit] menu of the FB editor, select [Insert Connection (C)...]. The mouse cursor will be changed to the cross mark.
- (11) Move the mouse pointer to the input/output terminal of the connection source function block and press the left mouse button.
- (12) Keep the left mouse button pressed and drag the cross cursor to the input/output terminal of the function block of the connection destination.
- (13) Release the left mouse button.
A line (connection) is inserted between the position where the mouse button is pressed and the position where mouse button is released. Only straight line is drawn to connect two points. If the function blocks are not connected using one straight line, connect multiple connections to connect the function blocks.

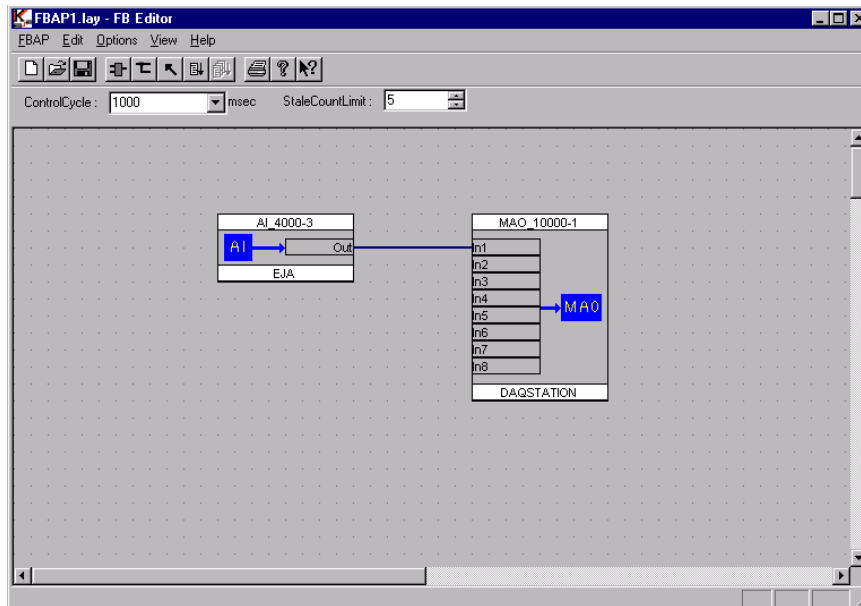

Figure 68. Connect between Function Blok

- (14) From the [Edit (E)] menu of the FB editor, select [Generation (G)] or click the [Generation] icon on the toolbar.
The dialog box prompting you to execute the generation will appear.
- (15) Click the "OK" button.
The dialog box showing that the generation is in progress will appear. When the generation is completed successfully, the schedule auto creation function will be started up. The execution timing chart necessary for creation of the schedule is then generated.
The dialog box showing that the FB editor generation is completed successfully will appear.



Figure 69. Generation Successful dialog

If the generation is failed due to incorrect configuration data settings, the dialog box showing that an error occurs will appear.

- (16) Click the "OK" button.
The dialog box will be closed.

- (17) From the [Edit (E)] menu of the FB editor, select [Schedule] or click the [Schedule] icon on the toolbar.
The "Schedule" dialog box will appear.

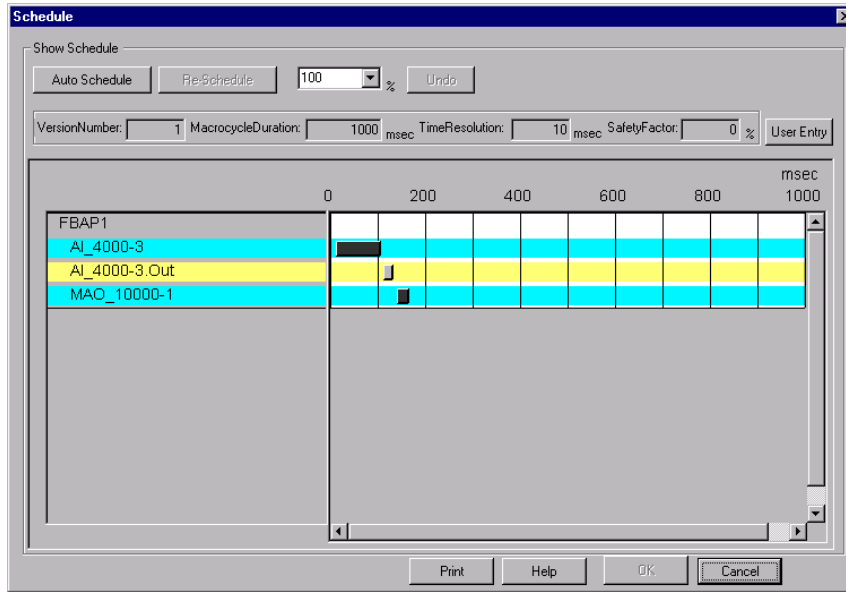

Figure 70. Schedule dialog

- (18) Follow steps Section 3.2.5.2, 3.2.5.3 to do the mapping of DAQSTATION
- (19) From the [Project] menu of Project Manager, select [Upload...].

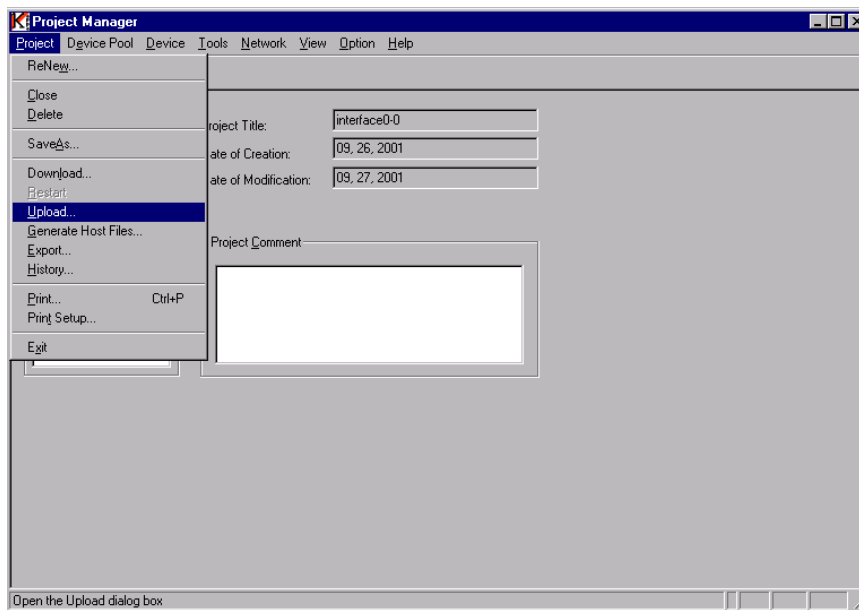

Figure 71. Execute Upload

The "Upload" dialog box will appear.

- (20) Select the transducer block of DAQSTATION.
- (21) With the upload object selected, click the "Execute" button.

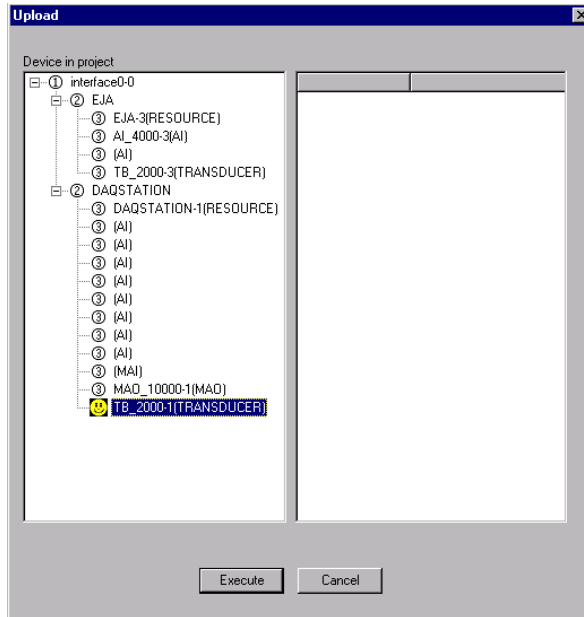

Figure 72. Upload dialog

- (22) The message showing the upload execution progress status will appear in the "Message" dialog box. All messages are saved into the text file (upload.log) located under the "Log" directory while the upload is being executed. Additionally, the progress bar also shows the upload execution progress status.

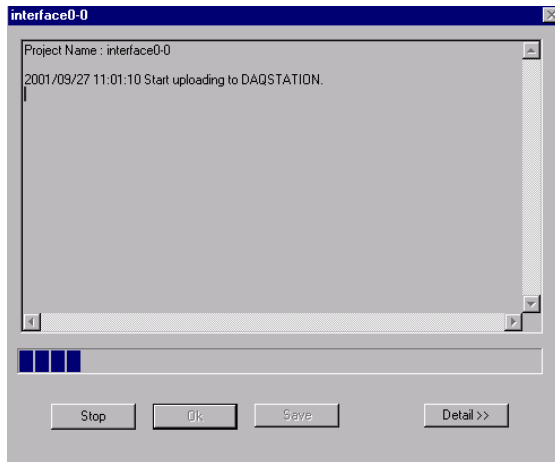

Figure 73. Message dialog

The following shows the list of messages shown in the "Message" dialog box.

- Start uploading of ** block of ** device.
- Complete uploading of ** block of ** device.
- Note: Relevant physical device tag name or block tag name is shown in "**".

- (23) From the [Edit (E)] menu of the network editor, select [All Parameters...]. The "All Parameters" edit dialog box will appear.

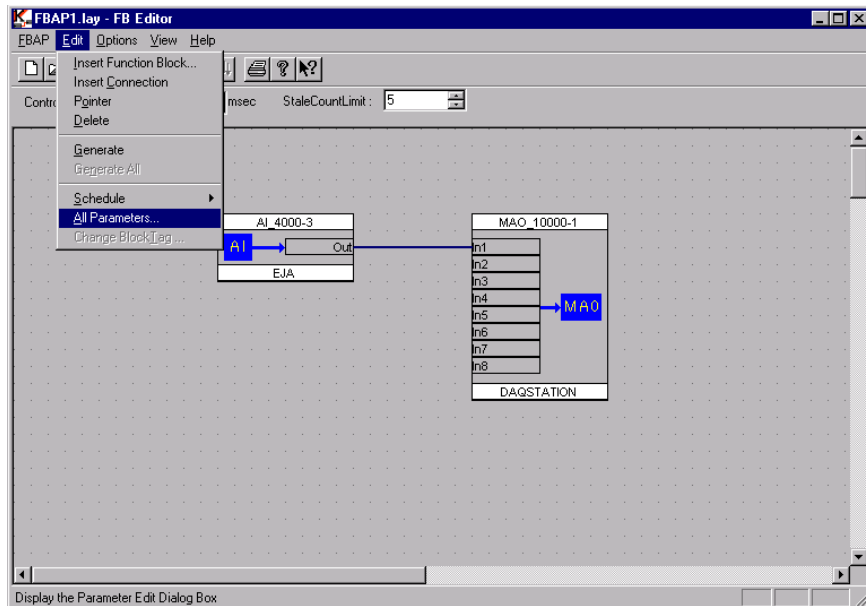

Figure 74. Modify Parameter (DAQSTATION)

- (24) In the "All Parameters" edit dialog box, "Device in Project" shows the project, common part or device, group, and element hierarchically.
- (25) Select the transducer block of DAQSTATION in "Device in Project". The list of parameters to be edited is shown in the list view on the right of the screen. Select "MAO_MAP" and input "parameter value: 1" in the "Value" box using any of the following operating procedures.

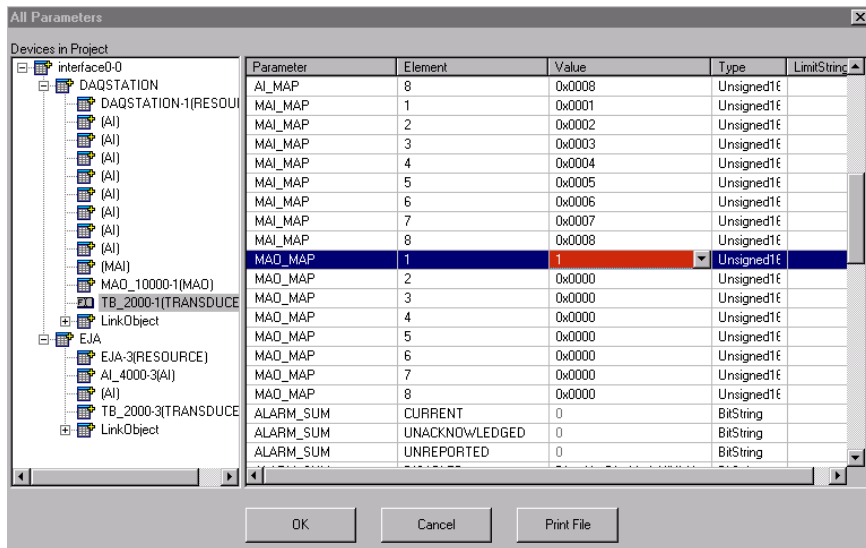

Figure 75. Parameter list (DAQSTATION)

- (26) Click the "OK" button. The "All Parameters" edit dialog box will be closed and the settings will be saved into the project database.

4.2.4 Downloading the FBAP Configuration

- (1) From the [Project] menu of Project Manager, select [Download]. The "Download" dialog box will appear.

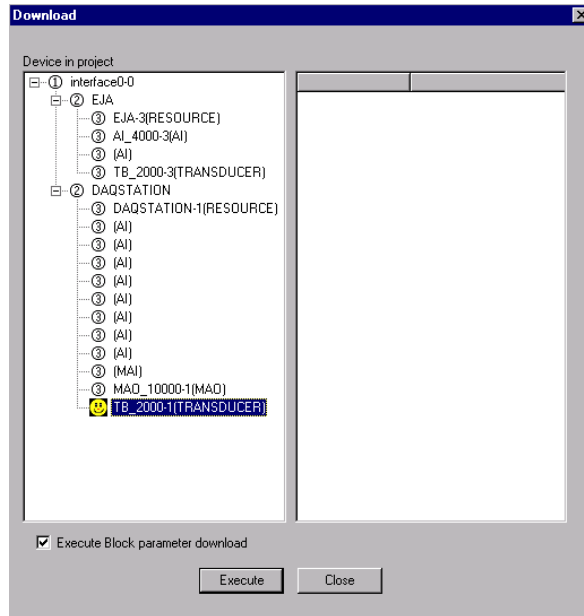

Figure 76. Download dialog

- (2) Select the transducer block of DAQSTATION. Next, check on "Execute Block parameter download" and download the parameters.
- (3) With the download object selected, click the "Execute" button. The dialog box showing the message, "Did you execute block parameter upload?", will appear. If you click the "OK" button in this dialog box, the parameter download is then executed.

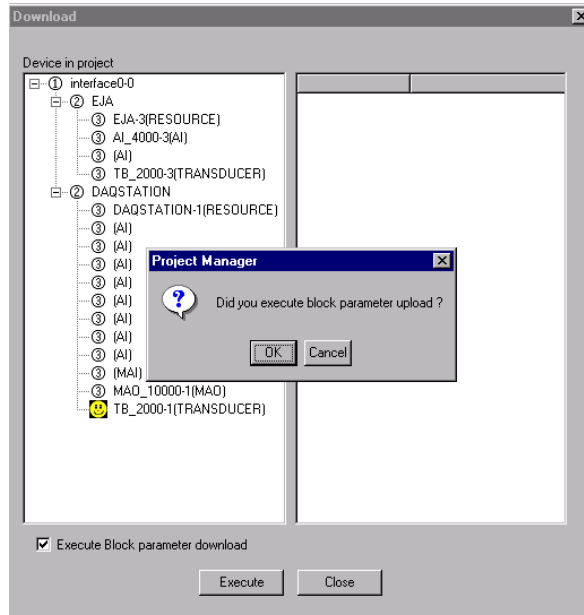

Figure 77. Message dialog

- (4) The message showing the download execution progress status will appear in the "Message" dialog box.

- (5) Select the interface0-0, click the "Execute" button, and download the parameters

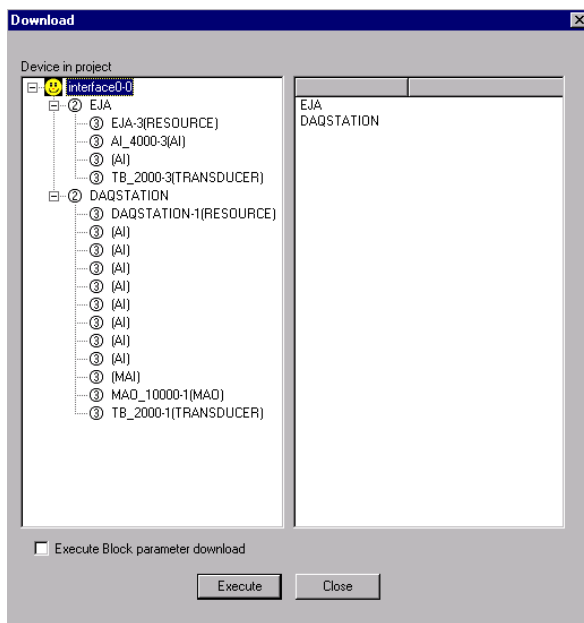

Figure 78. Download dialog (Selected the interface0-0)

- (6) The message showing the download progress status will appear in the "Message" dialog box. In this the setting ending.
- (7) It confirms that the device works by another software (Device Management Tool). Details refer to IM33S5P10-01.
- (8) Regarding DAQSTATION, refer to the section 3.3.2.

Blank Page

5. Appendix

5.1 NI-FBUS Error Codes

The table below shows the error codes for the NI-FBUS.

Table 14. NI-FBUS Error Codes

Code	Error
0	E_OK
-1	E_INVALID_DESCRIPTOR
-2	E_NOT_FOUND
-3	E_MULTIPLE
-4	E_TIMEOUT
-5	E_BAD_ARGUMENT
-6	E_RESOURCES
-7	E_BUF_TOO_SMALL
-8	E_CONFIG_ERROR
-9	E_SYMBOL_FILE_NOT_FOUND
-10	E_CONCURRENCY_FULL
-11	E_COMM_ERROR
-12	E_OBSOLETE_DESC
-13	E_SERVER_NOT_RESPONDING
-14	E_OBSOLETE_DEVICE
-15	E_VCR_FULL
-16	E_LINKAGE_FULL
-17	E_TREND_FULL
-18	E_DEVICE_NOT_CLEARED
-19	E_PUB_VCR_NOT_CONFIGURED
-20	E_LAS_SCHED_FULL
-21	E_FB_SCHED_FULL
-22	E_DEVICE_IS_NOT_MASTER
-23	E_SCHED_NOT_IN_DEVICE
-24	E_DD_LOOKUP_FAILED
-25	E_DD_LOAD_FAILED
-26	E_DD_TYPE_UNSUPPORTED
-27	E_ORDINAL_NUM_OUT_OF_RANGE
-28	E_SM_NOT_OPERATIONAL
-29	E_SM_NOT_INITIALIZED
-30	E_OBJECT_UNDEFINED
-31	E_DEVICE_OUT_OF_MEMORY
-32	E_OBJECT_STATE_CONFLICT
-33	E_ILLEGAL_PARAMETER
-34	E_OBJECT_ACCESS_DENIED
-35	E_OBJECT_ACCESS_UNSUPPORTED
-36	E_ACC_ELEM_UNSUPPORTED
-37	E_PARAMETER_CHECK
-38	E_EXCEED_LIMIT
-39	E_WRONG_MODE_FOR_REQUEST
-40	E_WRITE_IS_PROHIBITED
-41	E_DATA_NEVER_WRITABLE
-42	E_BLOCK_INSTANTIATE_FAILURE
-43	E_BLOCK_DELETE_FAILURE
-44	E_ALARM_ACKNOWLEDGED
-45	E_SERVER_CONNECTION_LOST

-46	E_OTHER
-47	E_BAD_DEVICE_DATA
-48	E_TOO_MANY_ENTRIES_SPECIFIED
-49	E_PARTIAL_CONFIG
-50	E_DEVICE_CHANGED
-51	E_OBSOLETE_BLOCK
-52	E_APPLICATION_UNREACHABLE
-53	E_VFD_CHANGED
-54	E_NETWORK_DISTURBED
-55	E_METHOD_ALREADY_EXECUTING
-56	E_RUNTIME_ERROR
-57	E_BUF_TOO_LARGE
-58	E_ASSEMBLY_OBJECT_FULL
-59	E_INVALID_INTERFACE
-60	E_ACTION_OBJECTS_UNSUPPORTED