

## YASKAWA AC Drive Z1000

### AC Drive Bypass for HVAC Fans and Pumps

# Technical Manual

Type: Z1B1

Models: 208 V: 1/2 to 100 HP  
480 V: 3/4 to 250 HP

To properly use the product, read this manual thoroughly and retain for easy reference, inspection, and maintenance. Ensure the end user receives this manual.

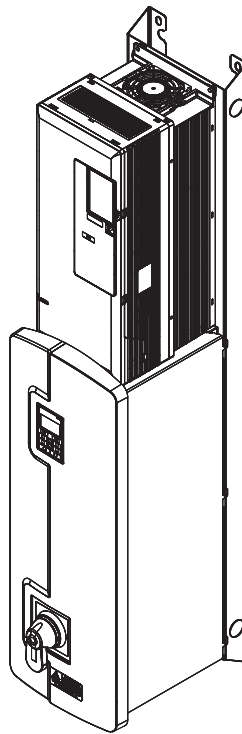

Receiving **1**

Mechanical Installation **2**

Electrical Installation **3**

Start-Up Programming & Operation **4**

Programming **5**

Diagnostics & Troubleshooting **6**

Peripheral Devices & Options **7**

Periodic Inspection & Maintenance **8**

Specifications **A**

Parameter List **B**

BACnet Communications **C**

MEMOBUS/Modbus Communications **D**

Apogee FLN Network Protocol **E**

Metasys N2 Network Protocol **F**

Standards Compliance **G**

Quick Reference Sheet **H**

---

**This Page Intentionally Blank**

Copyright © 2012 YASKAWA AMERICA, INC. All rights reserved.

No part of this publication may be reproduced, stored in a retrieval system, or transmitted, in any form or by any means, mechanical, electronic, photocopying, recording, or otherwise, without the prior written permission of Yaskawa. No patent liability is assumed with respect to the use of the information contained herein. Moreover, because Yaskawa is constantly striving to improve its high-quality products, the information contained in this manual is subject to change without notice. Every precaution has been taken in the preparation of this manual. Yaskawa assumes no responsibility for errors or omissions. Neither is any liability assumed for damages resulting from the use of the information contained in this publication.

# Table of Contents

---

<b>i. PREFACE &amp; GENERAL SAFETY</b> .....	<b>13</b>
<b>i.1 Preface</b> .....	<b>14</b>
Product Description .....	14
Applicable Documentation.....	14
Symbols.....	14
Terms and Abbreviations .....	15
Trademarks .....	15
<b>i.2 General Safety</b> .....	<b>16</b>
Supplemental Safety Information .....	16
Safety Messages.....	17
General Application Precautions .....	18
Motor Application Precautions.....	19
Drive Label Warning Example.....	20
Bypass Label Warning Example .....	21
Warranty Information.....	23
<b>1. RECEIVING</b> .....	<b>25</b>
<b>1.1 Section Safety</b> .....	<b>26</b>
<b>1.2 General Description</b> .....	<b>27</b>
Control Mode Details.....	27
<b>1.3 Model Numbers and Nameplate Checks</b> .....	<b>28</b>
Drive Nameplate.....	28
Bypass Nameplate .....	29
Bypass Enclosures.....	30
Bypass Product Options.....	30
<b>1.4 Bypass Component Descriptions</b> .....	<b>31</b>
Bypass Front Control Panel .....	31
<b>1.5 Bypass Component Names</b> .....	<b>33</b>
Front Views .....	35
<b>2. MECHANICAL INSTALLATION</b> .....	<b>37</b>
<b>2.1 Section Safety</b> .....	<b>38</b>
<b>2.2 Mechanical Installation</b> .....	<b>40</b>
Installation Environment.....	40
Installation Orientation and Spacing.....	41
Exterior and Mounting Dimensions .....	42

<b>3. ELECTRICAL INSTALLATION .....</b>	<b>49</b>
<b>3.1 Section Safety.....</b>	<b>50</b>
<b>3.2 Standard Connection Diagram.....</b>	<b>52</b>
<b>3.3 Main Circuit Wiring.....</b>	<b>56</b>
Removing/Reattaching the Bypass Front Cover .....	56
Bypass Main Circuit Terminal Block Configuration .....	60
<b>3.4 Input and Output Power Wiring Connections.....</b>	<b>61</b>
Factory Recommended Branch Circuit Protection .....	61
Main Circuit Terminal Functions.....	62
Wire Gauge and Tightening Torque Specifications.....	62
Main Input Circuit and Motor Wiring .....	63
Wiring the Main Input Circuit .....	67
<b>3.5 Control Circuit Wiring .....</b>	<b>70</b>
Control Circuit Connection Diagram.....	70
Control Circuit Terminal Block Functions .....	70
Bypass Analog Outputs.....	72
Serial Communications .....	72
Drive Cover Removal .....	73
Wiring the Drive Control Circuit Terminal.....	80
Switches and Jumpers on the Control Board .....	84
<b>3.6 Bypass and Drive Control I/O Connections .....</b>	<b>85</b>
Input Signal Selection for Terminals A1 and A2.....	85
Terminal FM/AM Signal Selection .....	85
<b>3.7 External Interlock .....</b>	<b>86</b>
Annunciation Contact Outputs.....	86
Building Automation System Run/Stop Circuit .....	86
Safety Interlock Circuit .....	86
Building Automation System Interlock Circuit (Drive and Bypass Enable Input).....	86
Remote Transfer to Bypass.....	87
Smoke Purge Operation.....	87
Spare Multi-Function Digital Inputs .....	87
<b>4. START-UP PROGRAMMING &amp; OPERATION.....</b>	<b>89</b>
<b>4.1 Section Safety.....</b>	<b>90</b>
<b>4.2 Using the HOA Keypad .....</b>	<b>91</b>
HOA Keypad and Control Panel Display.....	91
HOA Keypad Keys and Displays.....	92
LCD Display .....	93
Bypass Control Board LEDs.....	95
ALARM (ALM) LED Displays.....	95
AUTO LED and HAND LED Indications .....	95
HOA Keypad Menu Structure.....	97
HOA Keypad Parameter Display (Drive Off) .....	97
<b>4.3 The Drive and Programming Modes.....</b>	<b>99</b>
Changing Parameter Settings or Values .....	99
Verifying Parameter Changes: Modified Constants .....	100
Simplified Setup Using the Quick Setting Group.....	101
<b>4.4 Powering Up the Drive .....</b>	<b>103</b>
Powering Up the Drive and Operation Status Display.....	103

<b>4.5</b>	<b>Start-Up Procedure .....</b>	<b>104</b>
	Bypass Start-Up Preparation.....	104
	Bypass Start-Up Procedure.....	105
<b>4.6</b>	<b>Application Selection .....</b>	<b>108</b>
	Setting 1: Fan Application .....	108
	Setting 2: Fan with PI Control Application .....	108
	Setting 3: Return Fan with PI Control Application .....	108
	Setting 4: Cooling Tower Fan Application .....	109
	Setting 5: Cooling Tower Fan with PI Control Application.....	109
	Setting 6: Pump (Secondary) Application.....	110
	Setting 7: Pump with PI Control Application.....	110
<b>4.7</b>	<b>Auto-Tuning .....</b>	<b>111</b>
	Types of Auto-Tuning .....	111
	Before Auto-Tuning the Drive.....	111
	Auto-Tuning Interruption and Fault Codes .....	112
	Auto-Tuning Operation Example .....	112
	T1: Parameter Settings during Induction Motor Auto-Tuning.....	114
<b>5.</b>	<b>PROGRAMMING .....</b>	<b>117</b>
<b>5.1</b>	<b>A: Initialization.....</b>	<b>118</b>
	A1: Initialization .....	118
<b>5.2</b>	<b>b: Application.....</b>	<b>119</b>
	b1: Operation Mode Selection.....	119
	b2: DC Injection Braking and Short Circuit Braking.....	121
	b3: Speed Search.....	122
	b5: PI Control .....	128
<b>5.4</b>	<b>C: Tuning.....</b>	<b>139</b>
	C1: Acceleration and Deceleration Times .....	139
	C2: S-Curve Characteristics.....	139
	C4: Torque Compensation .....	140
	C6: Carrier Frequency.....	140
<b>5.5</b>	<b>d: Reference Settings .....</b>	<b>142</b>
	d1: Frequency Reference.....	142
	d2: Frequency Upper/Lower Limits .....	143
	d3: Jump Frequency.....	144
<b>5.6</b>	<b>E: Motor Parameters .....</b>	<b>145</b>
	E1: V/f Pattern for Motor 1.....	145
	E2: Motor 1 Parameters .....	149
<b>5.7</b>	<b>F: Options.....</b>	<b>150</b>
	F6: Drive/Bypass Communications .....	150
<b>5.8</b>	<b>H: Terminal Functions.....</b>	<b>151</b>
	H1: Multi-Function Digital Inputs .....	151
	H2: Multi-Function Digital Outputs.....	153
	H3: Multi-Function Analog Inputs .....	160
	H4: Multi-Function Analog Outputs .....	165
	H5: MEMOBUS/Modbus Serial Communication .....	167
<b>5.9</b>	<b>L: Protection Functions .....</b>	<b>168</b>
	L1: Motor Protection .....	168
	L2: Momentary Power Loss Ride-Thru.....	169

## Table of Contents

---

L3: Stall Prevention .....	170
L4: Reference Detection.....	173
L5: Fault Restart.....	174
L6: Torque Detection.....	176
L8: Drive Protection.....	179
<b>5.10 n: Special Adjustments.....</b>	<b>181</b>
n1: Hunting Prevention.....	181
n3: High Slip Braking (HSB) and Overexcitation Braking.....	181
<b>5.11 o: Operator-Related Settings .....</b>	<b>183</b>
o1: HOA Keypad Display Selection.....	183
o2: HOA Keypad Functions.....	185
o4: Maintenance Monitor Settings.....	185
<b>5.12 S: Special Parameters.....</b>	<b>187</b>
S1: Dynamic Audible Noise Control Function .....	187
S2: Sequence Timers.....	188
Examples of Sequence Timers .....	190
<b>5.13 T: Motor Tuning .....</b>	<b>194</b>
<b>5.14 U: Monitor Parameters .....</b>	<b>195</b>
UB: Bypass Monitors.....	195
U1: Operation Status Monitors .....	195
U2: Fault Trace.....	195
U3: Fault History.....	195
U4: Maintenance Monitors .....	195
U5: PI Monitors.....	195
<b>5.15 Z: Bypass Parameters.....</b>	<b>196</b>
Z1: Bypass Control System.....	196
Z2: Bypass Control Input/Output.....	210
Z3: Bypass Control Communication.....	214
Z4: Ethernet Option Bypass Control.....	218
<b>6. DIAGNOSTICS &amp; TROUBLESHOOTING .....</b>	<b>221</b>
<b>6.1 Section Safety.....</b>	<b>222</b>
<b>6.2 Motor Performance Fine-Tuning .....</b>	<b>224</b>
Fine-Tuning V/f Control .....	224
Parameters to Minimize Motor Hunting and Oscillation .....	224
<b>6.3 Drive Alarms, Faults, and Errors .....</b>	<b>225</b>
Types of Alarms, Faults, and Errors.....	225
Alarm and Error Displays .....	226
<b>6.4 Fault Detection .....</b>	<b>229</b>
Fault Displays, Causes, and Possible Solutions .....	229
<b>6.5 Alarm Detection.....</b>	<b>245</b>
Alarm Codes, Causes, and Possible Solutions.....	245
<b>6.6 Programming Errors .....</b>	<b>252</b>
Programming Error Codes, Causes, and Possible Solutions.....	252
<b>6.7 Auto-Tuning Fault Detection .....</b>	<b>255</b>
Auto-Tuning Codes, Causes, and Possible Solutions.....	255
<b>6.8 Diagnosing and Resetting Faults.....</b>	<b>257</b>
Fault Occurs Simultaneously with Power Loss .....	257

If the Drive Still has Power After a Fault Occurs .....	257
Viewing Fault Trace Data After Fault .....	257
Fault Reset Methods .....	258
<b>6.9 Troubleshooting without Fault Display .....</b>	<b>259</b>
Common Problems.....	259
Cannot Change Parameter Settings .....	259
Motor Does Not Rotate Properly after Pressing AUTO Button or after Entering External Run Command .....	260
Motor is Too Hot.....	261
oPE02 Error Occurs When Lowering the Motor Rated Current Setting .....	262
Motor Stalls during Acceleration or Acceleration Time is Too Long .....	262
Drive Frequency Reference Differs from the Controller Frequency Reference Command .....	262
Excessive Motor Oscillation and Erratic Rotation.....	263
Deceleration Takes Longer Than Expected .....	263
Noise From Drive or Motor Cables When the Drive is Powered On .....	263
Ground Fault Circuit Interrupter (GFCI) Trips During Run .....	263
Connected Machinery Vibrates When Motor Rotates .....	263
PI Output Fault .....	264
Motor Rotates after the Drive Output is Shut Off (Motor Rotates During DC Injection Braking) .....	264
Output Frequency is Not as High as Frequency Reference.....	264
Sound from Motor.....	264
Motor Does Not Restart after Power Loss.....	265
<b>7. PERIPHERAL DEVICES &amp; OPTIONS .....</b>	<b>267</b>
<b>7.1 Section Safety.....</b>	<b>268</b>
<b>7.2 Bypass Communication Options .....</b>	<b>270</b>
Tools Required for Option Installation .....	270
<b>7.3 Option Installation Procedure .....</b>	<b>271</b>
Prior to Installing the Option .....	271
Remove the Bypass Front Cover .....	273
Install the Option .....	277
Option Programming and Troubleshooting .....	280
<b>8. PERIODIC INSPECTION &amp; MAINTENANCE .....</b>	<b>281</b>
<b>8.1 Section Safety.....</b>	<b>282</b>
<b>8.2 Inspection .....</b>	<b>284</b>
Recommended Daily Inspection.....	284
Recommended Periodic Inspection.....	285
<b>8.3 Periodic Maintenance .....</b>	<b>287</b>
Replacement Parts.....	287
<b>8.4 HOA Keypad Battery Replacement.....</b>	<b>289</b>
Real-Time Clock Adjustment.....	289
<b>8.5 Drive Cooling Fans.....</b>	<b>291</b>
Number of Cooling Fans .....	291
Drive Cooling Fan Component Names.....	292
Cooling Fan Replacement: 2A0011 to 2A0059, 4A0005 to 4A0040, and 4A0052□□B .....	293
Cooling Fan Replacement: 2A0075 to 2A0114, 4A0052□□A, and 4A0065 to 4A0096 .....	297
Cooling Fan Replacement: 4A0124 .....	302
Cooling Fan Replacement: 2A0143 to 2A0273, 4A0156 to 4A0240 .....	308
Cooling Fan Replacement: 2A0343 and 2A0396.....	310

Cooling Fan Replacement: 4A0302 .....	312
<b>A. SPECIFICATIONS .....</b>	<b>315</b>
<b>A.1 Power Ratings .....</b>	<b>316</b>
Three-Phase 208 Vac Models Z1B1D002 to D046 .....	316
Three-Phase 208 Vac Models Z1B1D059 to D273 .....	317
Three-Phase 480 Vac Models Z1B1B001 to B034 .....	318
Three-Phase 480 Vac Models Z1B1B040 to B302 .....	319
<b>A.2 Drive Specifications .....</b>	<b>320</b>
<b>A.3 Drive Watt Loss Data .....</b>	<b>322</b>
<b>A.4 Drive Derating Data .....</b>	<b>324</b>
Carrier Frequency Derating .....	324
Altitude Derating .....	324
<b>A.5 Bypass Options .....</b>	<b>325</b>
Option B .....	325
Option D .....	325
Option M .....	325
Option G .....	325
Option L .....	325
Option W .....	325
<b>B. PARAMETER LIST .....</b>	<b>327</b>
<b>B.1 Parameter Groups .....</b>	<b>328</b>
<b>B.2 A: Initialization Parameters .....</b>	<b>329</b>
A1: Initialization .....	329
<b>B.3 b: Application.....</b>	<b>330</b>
b1: Operation Mode Selection.....	330
b2: DC Injection Braking and Short Circuit Braking.....	330
b3: Speed Search.....	330
b5: PI Control .....	331
<b>B.4 C: Tuning.....</b>	<b>334</b>
C1: Acceleration and Deceleration Times .....	334
C2: S-Curve Characteristics .....	334
C4: Torque Compensation .....	334
C6: Carrier Frequency .....	334
<b>B.5 d: References.....</b>	<b>335</b>
d1: Frequency Reference .....	335
d2: Frequency Upper/Lower Limits .....	335
d3: Jump Frequency.....	335
<b>B.6 E: Motor Parameters .....</b>	<b>337</b>
E1: V/f Pattern for Motor 1 .....	337
E2: Motor Parameters .....	337
<b>B.7 F: Options.....</b>	<b>338</b>
F6: Drive/Bypass Communications .....	338
<b>B.8 H Parameters: Multi-Function Terminals .....</b>	<b>339</b>
H1: Multi-Function Digital Inputs .....	339
H2: Multi-Function Digital Outputs.....	340
H3: Multi-Function Analog Inputs .....	341



H4: Analog Outputs .....	343
H5: MEMOBUS/Modbus Serial Communication .....	343
<b>B.9 L: Protection Function .....</b>	<b>344</b>
L1: Motor Protection .....	344
L2: Momentary Power Loss Ride-Thru .....	344
L3: Stall Prevention .....	344
L4: Speed Detection .....	345
L5: Fault Restart .....	345
L6: Torque Detection .....	346
L8: Drive Protection .....	346
<b>B.10 n: Special Adjustment .....</b>	<b>347</b>
n1: Hunting Prevention .....	347
n3: High Slip Braking (HSB) and Overexcitation Braking .....	347
<b>B.11 o: Operator-Related Settings .....</b>	<b>348</b>
o1: HOA Keypad Display Selection .....	348
o2: HOA Keypad Functions .....	348
o4: Maintenance Monitor Settings .....	349
<b>B.12 S: Special Application .....</b>	<b>350</b>
S1: Dynamic Noise Control Function .....	350
S2: Sequence Timers .....	350
T: Motor Tuning .....	352
T1: Induction Motor Auto-Tuning .....	352
<b>B.13 U: Monitors .....</b>	<b>354</b>
UB: Bypass Control Monitors .....	354
U1: Operation Status Monitors .....	355
U2: Fault Trace .....	357
U3: Fault History .....	358
U4: Maintenance Monitors .....	360
U5: PI Monitors .....	361
U6: Operation Status Monitors .....	362
<b>B.14 Z: Bypass Parameters .....</b>	<b>363</b>
Z1: Bypass Control System .....	363
Z2: Bypass Control Input/Output .....	367
Z3: Bypass Control Communication .....	368
Z4: Bypass Control Option Boards .....	370
<b>B.15 Defaults by Drive Model .....</b>	<b>372</b>
<b>C. BACNET COMMUNICATIONS .....</b>	<b>375</b>
<b>C.1 BACnet Configuration .....</b>	<b>376</b>
<b>C.2 Communication Specifications .....</b>	<b>377</b>
<b>C.3 Connecting to a Network .....</b>	<b>378</b>
Network Cable Connection .....	378
Wiring Diagram for Multiple Connections .....	379
Network Termination .....	379
<b>C.4 BACnet Setup Parameters .....</b>	<b>380</b>
BACnet Serial Communication .....	380
<b>C.5 Bypass Operations by BACnet .....</b>	<b>382</b>
Observing the Bypass Operation .....	382
Controlling the Bypass .....	382

<b>C.6</b>	<b>BACnet Objects Supported .....</b>	<b>383</b>
	Present Value Access .....	383
	Supported Properties of Objects .....	383
	Analog Input Objects .....	384
	Analog Output Objects .....	384
	Analog Value Objects .....	384
	Binary Input Objects .....	386
	Binary Output Objects .....	386
	Binary Value Objects .....	387
	Device Object .....	389
<b>C.7</b>	<b>Accessing Bypass Parameters and the Enter Command .....</b>	<b>390</b>
	Reading Bypass Parameters .....	390
	Writing Bypass Parameters .....	390
	Enter Command .....	390
<b>C.8</b>	<b>Communication Errors .....</b>	<b>391</b>
<b>C.9</b>	<b>BACnet Protocol Implementation Conformance Statement.....</b>	<b>392</b>
<b>D.</b>	<b>MEMOBUS/MODBUS COMMUNICATIONS.....</b>	<b>395</b>
<b>D.1</b>	<b>MEMOBUS/Modbus Configuration .....</b>	<b>396</b>
<b>D.2</b>	<b>Communication Specifications .....</b>	<b>397</b>
<b>D.3</b>	<b>Connecting to a Network .....</b>	<b>398</b>
	Network Cable Connection.....	398
	Wiring Diagram for Multiple Connections .....	399
	Network Termination .....	399
<b>D.4</b>	<b>MEMOBUS/Modbus Setup Parameters .....</b>	<b>400</b>
	MEMOBUS/Modbus Serial Communication .....	400
<b>D.5</b>	<b>Bypass Operations by MEMOBUS/Modbus .....</b>	<b>402</b>
	Observing the Bypass Operation .....	402
<b>D.6</b>	<b>Communications Timing.....</b>	<b>403</b>
	Command Messages from Master to Bypass .....	403
	Response Messages from Bypass to Master .....	403
<b>D.7</b>	<b>Message Format .....</b>	<b>404</b>
	Message Content .....	404
	Slave Address .....	404
	Function Code .....	404
	Data .....	404
	Error Check .....	404
<b>D.8</b>	<b>Message Examples .....</b>	<b>406</b>
	Reading Drive MEMOBUS/Modbus Register Contents .....	406
	Loopback Test.....	406
	Writing to Multiple Registers.....	407
<b>D.9</b>	<b>MEMOBUS/Modbus Data Table.....</b>	<b>408</b>
	Command Data .....	408
	Monitor Data .....	409
	Broadcast Messages .....	418
	Fault Trace Contents .....	418
	Bypass Fault Codes .....	420
	Alarm Register Contents .....	420

<b>D.10 Enter Command</b> .....	<b>421</b>
Enter Command Behavior .....	421
<b>D.11 Communication Errors</b> .....	<b>422</b>
MEMOBUS/Modbus Error Codes.....	422
Slave Not Responding.....	422
<b>E. APOGEE FLN NETWORK PROTOCOL</b> .....	<b>423</b>
<b>E.1 APOGEE FLN Set-Up</b> .....	<b>424</b>
Z1000 Bypass Parameter Settings for APOGEE FLN Communications.....	424
<b>E.2 Connecting to a Network</b> .....	<b>425</b>
Network Cable Connection.....	425
Wiring Diagram for Multiple Connections .....	426
Network Termination .....	426
Recommended Cable.....	426
<b>E.3 Slope and Intercept Conversion</b> .....	<b>427</b>
Drive Controlled Feedback.....	427
Field Panel Controlled Feedback .....	427
Other Functionality .....	428
<b>E.4 APOGEE FLN Point List Summary</b> .....	<b>429</b>
<b>E.5 Cable Loss Configuration and Behavior</b> .....	<b>433</b>
Drive Behavior at Loss of Communication .....	433
Apogee FLN Points .....	433
<b>E.6 Mailbox Function</b> .....	<b>435</b>
Mailbox Function Points .....	435
<b>E.7 Fault Codes</b> .....	<b>436</b>
Communications Fault.....	436
Z1000 Bypass Faults–Apogee FLN Configuration .....	436
<b>F. METASYS N2 NETWORK PROTOCOL</b> .....	<b>439</b>
<b>F.1 N2 Specifications and Configuration</b> .....	<b>440</b>
<b>F.2 Connecting to a Network</b> .....	<b>441</b>
Network Cable Connection.....	441
Wiring Diagram for Multiple Connections .....	442
Network Termination .....	442
<b>F.3 N2 Setup Parameters</b> .....	<b>443</b>
N2 Serial Communication.....	443
<b>F.4 Bypass Operations by N2</b> .....	<b>446</b>
Observing the Bypass Operation .....	446
Controlling the Bypass .....	446
<b>F.5 Communications Timing</b> .....	<b>450</b>
Command Messages from Master to Bypass .....	450
Response Messages from Bypass to Master.....	450
<b>F.6 Metasys N2 Point Database</b> .....	<b>451</b>
Metasys N2 Analog Input (AI) Summary .....	451
Metasys N2 Analog Output (AO) Summary .....	452
Metasys N2 Binary Input (BI) Summary .....	452
Metasys N2 Binary Output (BO) Summary .....	453

<b>F.7 Mailbox Function</b> .....	<b>454</b>
Reading Drive Parameters .....	454
Writing Drive Parameters .....	454
<b>G. STANDARDS COMPLIANCE</b> .....	<b>455</b>
<b>G.1 Section Safety</b> .....	<b>456</b>
<b>G.2 European Standards</b> .....	<b>458</b>
CE Low Voltage Directive Compliance.....	458
EMC Guidelines Compliance .....	458
<b>G.3 UL/cUL Standards</b> .....	<b>459</b>
UL Standards Compliance .....	459
<b>H. QUICK REFERENCE SHEET</b> .....	<b>461</b>
<b>H.1 Z1000 Bypass and Motor Specifications</b> .....	<b>462</b>
Z1000 Bypass Specifications .....	462
Motor Specifications .....	462
<b>H.2 Basic Parameter Settings</b> .....	<b>463</b>
Quick Setting Parameters .....	463
Motor Setup.....	463
Multi-Function Digital Inputs .....	463
Analog Inputs .....	464
Multi-Function Digital Outputs .....	464
Monitor Outputs.....	464
<b>H.3 User Setting Table</b> .....	<b>465</b>
<b>INDEX</b> .....	<b>471</b>

# Preface & General Safety

---

This section provides safety messages pertinent to this product that, if not heeded, may result in fatality, personal injury, or equipment damage. Yaskawa is not responsible for the consequences of ignoring these instructions.

<b>i.1</b>	<b>PREFACE.....</b>	<b>14</b>
<b>i.2</b>	<b>GENERAL SAFETY.....</b>	<b>16</b>

## i.1 Preface

Yaskawa manufactures products used as components in a wide variety of industrial systems and equipment. The selection and application of Yaskawa products remain the responsibility of the equipment manufacturer or end user. Yaskawa accepts no responsibility for the way its products are incorporated into the final system design. Without exception, all controls should be designed to detect faults dynamically and fail safely under all circumstances. All systems or equipment designed to incorporate a product manufactured by Yaskawa must be supplied to the end user with appropriate warnings and instructions as to the safe use and operation of that part. Any warnings provided by Yaskawa must be promptly provided to the end user. Yaskawa offers an express warranty only as to the quality of its products in conforming to standards and specifications published in the Yaskawa manual. **NO OTHER WARRANTY, EXPRESS OR IMPLIED, IS OFFERED.** Yaskawa assumes no liability for any personal injury, property damage, losses, or claims arising from misapplication of its products.

This manual is designed to ensure correct and suitable application of the Z1000 Bypass. Read this manual before attempting to install, operate, maintain, or inspect the bypass unit and keep it in a safe, convenient location for future reference. Be sure you understand all precautions and safety information before attempting application.

### ◆ Product Description

The Z1000 Bypass provides a means of bypassing the drive while allowing the motor to operate at full speed, directly from the AC line. It incorporates an AC Drive and a two or three-contactor bypass arrangement in a single UL listed enclosure. The two electrically interlocked IEC rated contactors isolate the drive from the load when operating in Bypass mode.

Control logic provides industry standard Hand/Off/Auto functions, BAS Interlock, and safety circuit interlocks in both Drive and Bypass operating modes.

Bypass components include: a fused 120 Vac control circuit transformer, an input disconnect, motor overload, 5% input line impedance, and an HOA keypad with LCD display.

The Z1000 drive, a component of the Z1000 Bypass package, is a pulse width modulated drive for three-phase AC induction motors. This type of drive is also known as an adjustable frequency drive, variable frequency drive, AC Drive, AFD, ASD, VFD, and inverter.

The drive is a variable torque AC drive, designed specifically for HVAC applications in building automation, including fans, blowers and pumps.

The Z1000 Bypass has embedded communications for the popular building automation protocols, BACnet and Modbus®.

The LCD keypad/operator is equipped with Hand/Off/Auto functions. Optional DriveWizard software allows upload/download, as well as graphing and monitoring of drive parameters from a PC for ease of drive management.

Built-in PI control eliminates the need for closed loop output signals from a building automation system. It includes feedback display, inverse, square root and differential control functions, and maintains setpoint for closed loop control of fans and pumps for pressure, flow, or temperature regulation. An additional independent PI control is also provided for external devices.

### ◆ Applicable Documentation

The following manuals are available for the Z1000 Bypass:

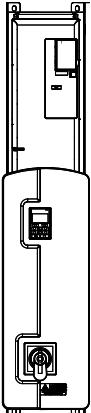
	<p><b>Z1000 Bypass Technical Manual (SIEPYAIZ1B01)</b></p> <p>Read this manual first. This manual is packaged together with the product and contains basic information required to install and wire the bypass. It also gives detailed information on fault diagnostics, parameter settings, and BACnet specifications. The purpose of this manual is to prepare the Z1000 Bypass for a trial run with an application and for basic operation. This manual is also available for download on the Yaskawa documentation website, <a href="http://www.yaskawa.com">www.yaskawa.com</a>.</p>
	<p><b>Z1000-Series AC Drive User Manual (TOEPC71061645)</b></p> <p>This manual contains basic information required to install and wire the drive. It also gives detailed information on fault diagnostics, parameter settings, and BACnet specifications. The purpose of this manual is to prepare the drive for a trial run with an application and for basic operation. This manual is available for download on the Yaskawa documentation website, <a href="http://www.yaskawa.com">www.yaskawa.com</a>.</p>
	<p><b>Z1000-Series AC Drive Programming Manual (SIEPC71061645)</b></p> <p>This manual provides detailed information on parameter settings, drive functions, maintenance, and MEMOBUS/Modbus specifications. Use this manual to expand drive functionality. This manual is available for download on the Yaskawa documentation website, <a href="http://www.yaskawa.com">www.yaskawa.com</a>.</p>

### ◆ Symbols

**Note:** Indicates a supplement or precaution that does not cause drive damage.



Indicates a term or definition used in this manual.

---

## ◆ Terms and Abbreviations



- **Bypass:** Yaskawa Z1000 Bypass
- **Drive:** Yaskawa Z1000-Series Drive
- **H:** Hexadecimal Number Format
- **IGBT:** Insulated Gate Bipolar Transistor
- **kbps:** Kilobits per Second
- **MAC:** Media Access Control
- **r/min:** Revolutions per Minute
- **V/f:** V/f Control

---

## ◆ Trademarks

This manual may describe trademarked equipment, which is the property of other companies. These trademarks are the property of the registered owner companies and may include the following:

- BACnet is a trademark of the American Society of Heating, Refrigerating, and Air-Conditioning Engineers (ASHRAE).
- APOGEE™ FLN, trademark of Siemens Building Technologies, Inc.
- EtherNet/IP is a trademark of the ODVA.
- Metasys®, trademark of Johnson Controls Inc.
- Modbus®, trademark of Schneider Automation, Inc.
- LonWorks®, trademark of Echelon Corporation
- PROFINET is a trademark of PROFIBUS and PROFINET International (PI).
- Other companies and product names mentioned in this manual are trademarks of those companies.

## i.2 General Safety

### ◆ Supplemental Safety Information

#### General Precautions

- The diagrams in this manual may be indicated without covers or safety shields to show details. Replace the covers or shields before operating the drive and run the drive according to the instructions described in this manual.
- Any illustrations, photographs, or examples used in this manual are provided as examples only and may not apply to all products to which this manual is applicable.
- The products and specifications described in this manual or the content and presentation of the manual may be changed without notice to improve the product and/or the manual.
- When ordering a new copy of the manual due to damage or loss, contact your Yaskawa representative or the nearest Yaskawa sales office and provide the manual number shown on the front cover.
- If nameplate becomes worn or damaged, order a replacement from your Yaskawa representative or the nearest Yaskawa sales office.

#### **WARNING**

Read and understand this manual before installing, operating or servicing this drive. The drive must be installed according to this manual and local codes.

The following conventions are used to indicate safety messages in this manual. Failure to heed these messages could result in serious or fatal injury or damage to the products or to related equipment and systems.

#### **DANGER**

Indicates a hazardous situation, which, if not avoided, will result in death or serious injury.

#### **WARNING**

Indicates a hazardous situation, which, if not avoided, could result in death or serious injury.

**WARNING!** may also be indicated by a bold key word embedded in the text followed by an italicized safety message.

#### **CAUTION**

Indicates a hazardous situation, which, if not avoided, could result in minor or moderate injury.

**CAUTION!** may also be indicated by a bold key word embedded in the text followed by an italicized safety message.

#### **NOTICE**

Indicates a property damage message.

**NOTICE:** may also be indicated by a bold key word embedded in the text followed by an italicized safety message.



## ◆ Safety Messages

### WARNING

#### **Heed the safety messages in this manual.**

Failure to comply could result in death or serious injury.

The operating company is responsible for any injuries or equipment damage resulting from failure to heed the warnings in this manual.

#### **Sudden Movement Hazard**

**System may start unexpectedly upon application of power, resulting in death or serious injury.**

Clear all personnel from the drive, motor and machine area before applying power. Secure covers, couplings, shaft keys and machine loads before applying power to the drive.

#### **Arc Flash Hazard**

**It is possible that there is more than one source of power for equipment.**

Obey the requirements for Electrical Safety in the Workplace and local codes for safe work procedures and applicable personal protective equipment (PPE). Failure to obey can cause serious injury or death.

#### **Electrical Shock Hazard**

**Do not connect or disconnect wiring while the power is on.**

Failure to comply could result in death or serious injury.

Before servicing, disconnect all power to the equipment. The internal capacitor remains charged even after the power supply is turned off. The charge indicator LED will extinguish when the DC bus voltage is below 50 Vdc. To prevent electric shock, wait for at least the time specified on the warning label, once all indicators are OFF, measure for unsafe voltages to confirm the drive is safe prior to servicing.

**Do not attempt to modify or alter the drive in any way not explained in this manual.**

Failure to comply could result in death or serious injury.

Yaskawa is not responsible for any modification of the product made by the user. This product must not be modified.

**Do not allow unqualified personnel to use equipment.**

Failure to comply could result in death or serious injury.

Maintenance, inspection, and replacement of parts must be performed only by authorized personnel familiar with installation, adjustment and maintenance of AC drives.

**Do not remove covers or touch circuit boards while the power is on.**

Failure to comply could result in death or serious injury.

**Make sure the protective earthing conductor complies with technical standards and local safety regulations.**

Because the leakage current exceeds 3.5 mA, IEC/EN 61800-5-1 states that either the power supply must be automatically disconnected in case of discontinuity of the protective earthing conductor or a protective earthing conductor with a cross-section of at least 10 mm<sup>2</sup> (Cu) or 16 mm<sup>2</sup> (Al) must be used. Failure to comply may result in death or serious injury.

**Always use appropriate equipment for Ground Fault Circuit Interrupters (GFCIs).**

The drive can cause a residual current with a DC component in the protective earthing conductor. Where a residual current operated protective or monitoring device is used for protection in case of direct or indirect contact, always use a type B GFCI according to IEC/EN 60755.

#### **Fire Hazard**

Branch Circuit protection is required to be installed according to applicable local codes and the requirements listed on the Z1000 Bypass nameplate. Failure to comply could result in fire and damage to the bypass and drive or injury to personnel. The Z1000 Bypass is suitable for use on a circuit capable of delivering not more than 100,000 RMS symmetrical amperes, 208 Vac and 480 Vac with the circuit breaker option or when protected by class J or class L fuses as specified on the Z1000 Bypass nameplate. Consult factory for additional information if needed.

### WARNING

#### **Do not use an improper voltage source.**

Failure to comply could result in death or serious injury by fire.

Verify that the rated voltage of the drive matches the voltage of the incoming power supply before applying power.

### NOTICE

#### **Observe proper electrostatic discharge procedures (ESD) when handling the drive and circuit boards.**

Failure to comply may result in ESD damage to the drive circuitry.

#### **Do not perform a withstand voltage test on any part of the drive.**

Failure to comply could result in damage to the sensitive devices within the drive.

#### **Do not operate damaged equipment.**

Failure to comply could result in further damage to the equipment.

Do not connect or operate any equipment with visible damage or missing parts.

#### **Do not expose the drive to halogen group disinfectants.**

Failure to comply may cause damage to the electrical components in the drive.

Do not pack the drive in wooden materials that have been fumigated or sterilized.

Do not sterilize the entire package after the product is packed.

#### **Do not use screws of different sizes in SW1 and SW2.**

Failure to comply may cause overheating and electrical damage.

## ◆ General Application Precautions

### ■ Selection

#### **Installing a Reactor**

Use an AC reactor in the following situations:

- to suppress harmonic current.
- when the drive is running from a power supply system with thyristor converters.

#### **Drive Capacity**

For specialized motors, make sure that the motor rated current is less than the rated output current for the drive.

When running more than one motor in parallel from a single drive, the capacity of the drive should be larger than [total motor rated current × 1.1].

#### **Starting Torque**

The startup and acceleration characteristics of the motor are restricted to the drive overload current rating.

The overload rating for the drive determines the starting and accelerating characteristics of the motor. Expect lower torque than when running from line power. To achieve a higher starting torque, use a larger drive or a drive and motor with larger capacity.

#### **Emergency Stop**

During a drive fault condition, the output shuts off but the motor does not stop immediately. A mechanical brake may be required when it is necessary to stop the motor faster than the ability of the Fast Stop function of the drive.

### ■ Installation

#### **Enclosure Panels**

Keep the drive in a clean environment. Be sure to leave the required space between drives to provide for cooling, and take proper measures so the ambient temperature remains within allowable limits and keep flammable materials away from the drive.

#### **Installation Direction**

**NOTICE:** Install the drive upright as specified in the manual. Refer to the Mechanical Installation section for more information on installation. Failure to comply may damage the drive due to improper cooling.

## ■ Settings

### Upper Limits

**NOTICE:** *The drive is capable of running the motor up to 240 Hz. Be sure to set the upper limit for the frequency of the drive to prevent the possible danger of accidentally operating equipment at higher than rated speed. The default setting for the maximum output frequency is 60 Hz.*

### DC Injection Braking

**NOTICE:** *Excessive current during DC Injection Braking and excessive duration of DC Injection Braking can cause motor overheating.*

### Acceleration/Deceleration Times

Acceleration and deceleration times are affected by the amount of torque generated by the motor, the load torque, and the moment of inertia. Set a longer accel/decel time when Stall Prevention is enabled. The accel/decel times are lengthened for as long as the Stall Prevention function is in operation. Install one of the available braking options or increase the capacity of the drive for faster acceleration and deceleration.

## ■ General Handling

### Wiring Check

**NOTICE:** *Do not connect power supply lines to output terminals U/T1, V/T2, or W/T3. Failure to comply will destroy the drive. Be sure to perform a final check of all sequence wiring and other connections before turning on the power and also check for short circuits on the control terminals, which may damage the drive.*

### Inspection and Maintenance

**WARNING!** *Electrical Shock Hazard. Capacitors in the drive do not immediately discharge after shutting off the power. Wait for at least the amount of time specified on the drive before touching any components after shutting off the power. Failure to comply may cause injury to personnel from electrical shock.*

### Transporting the Drive

**NOTICE:** *Never steam clean the drive. During transport, keep the drive from coming into contact with salts, fluorine, bromine, phthalate ester, and other such harmful chemicals.*

## ◆ Motor Application Precautions

### Insulation Tolerance

**NOTICE:** *Consider motor voltage tolerance levels and motor insulation in applications with an input voltage of over 480 V or particularly long wiring distances.*

### High-Speed Operation

**NOTICE:** *Problems may occur with the motor bearings and dynamic balance of the machine when operating a motor beyond its rated speed. Contact the motor or machine manufacturer.*

### Torque Characteristics

Torque characteristics differ compared to operating the motor directly from line power. The user should have a full understanding of the load torque characteristics for the application.

### Vibration and Shock

The drive allows selection of high carrier PWM control and low carrier PWM. Selecting high carrier PWM can help reduce motor oscillation.

Take particular caution when adding a variable speed drive to an application running a motor from line power at a constant speed. If resonance occurs, install shock-absorbing isolation mounts around the base of the motor and enable the Jump frequency selection to prevent continuous operation in the resonant frequency range.

### Audible Noise

The audible noise of the motor varies based on the carrier frequency setting. However, drive current derating may be required. When using a high carrier frequency, audible noise from the motor is comparable to the motor noise generated when running from line power.

### Specialized Motors

#### Multi-Pole Motor

The rated current of a multi-pole motor differs from that of a standard motor, so be sure to check the maximum current when selecting a drive. Always stop the motor before switching between the number of motor poles. The motor will coast to stop if a regenerative overvoltage (ov) fault occurs or if overcurrent (oC) protection is triggered.

#### Submersible Motor

The rated current of a submersible motor is greater than that of a standard motor, so select the drive accordingly. Use a motor cable large enough to avoid decreasing the maximum torque level from voltage drop caused by a long motor cable.

## i.2 General Safety

---

### Explosion-Proof Motor

The motor and the drive must be tested together to be certified as explosion-proof. The drive is not designed for explosion-proof areas.

### Geared Motor

Make sure that the gear and the lubricant are rated for the desired speed range to avoid gear damage when operating at low speeds or very high speeds. Consult with the manufacturer for applications that require operation outside the rated speed range of the motor or gear box.

### Single-Phase Motor

Variable speed drives are not designed to operate with single phase motors. Using capacitors to start the motor causes a high-frequency current to flow to the capacitors and can damage the capacitors. A split-phase start or a repulsion start can burn out the starter coils because the internal centrifugal switch is not activated. The drive is for use with three-phase motors only.

### Motor with Brake

Take caution when using the drive to operate a motor with a built-in holding brake. If the brake is connected to the output side of the drive, it may not release at start due to low voltage levels, so be sure to install a separate power supply for the motor brake. Note that motors with built-in brakes tend to generate a fair amount of noise when running at low speeds.

---

## ◆ Drive Label Warning Example

Always heed the warning information listed in *Figure i.1* in the position shown in *Figure i.2*.

 **WARNING**

---

 **Risk of electric shock.**

- Read manual before installing.
- Wait 5 minutes for capacitor discharge after disconnecting power supply.
- To conform to CE requirements, make sure to ground the supply neutral for 400V class.
- After opening the manual switch between the drive and motor, please wait 5 minutes before inspecting, performing maintenance or wiring the drive.

 **Hot surfaces**

- Top and Side surfaces may become hot. Do not touch.

Figure i.1 Warning Information Example

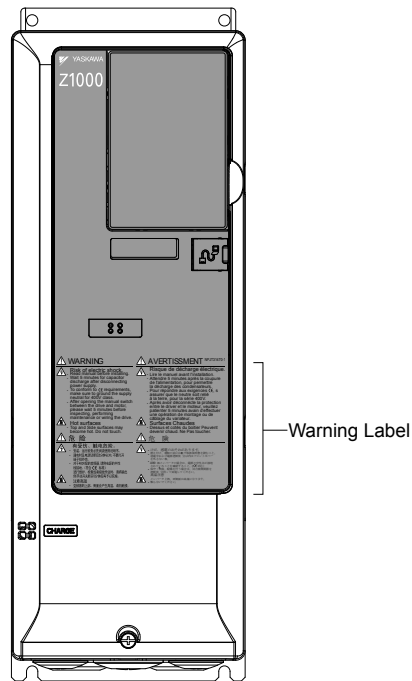

Figure i.2 Drive Warning Label Location

### ◆ Bypass Label Warning Example

Always heed the warning information listed in [Figure i.3](#) and [Figure i.4](#) in the positions shown in [Figure i.2](#).

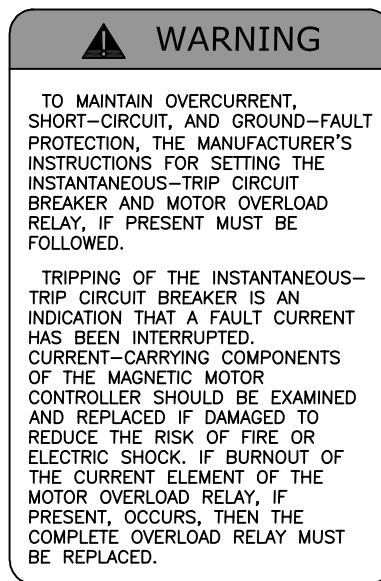
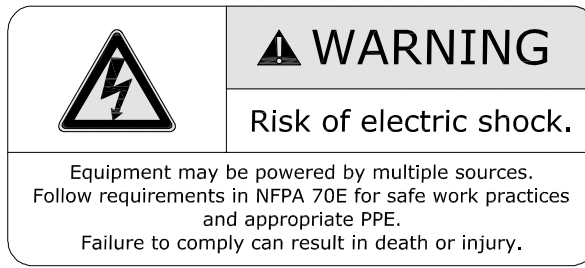
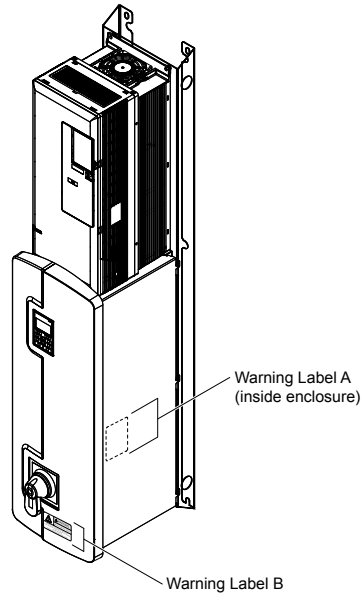

Figure i.3 Warning Information Example A



**Figure i.4 Warning Information Example B**



**Figure i.5 Bypass Warning Label Locations**

---

## ◆ Warranty Information

### ■ Scope of Warranty

#### Inspections

Customers are responsible for periodic inspections of the drive. Upon request, a Yaskawa representative will inspect the drive for a fee. If the Yaskawa representative finds the drive to be defective due to Yaskawa workmanship or materials and the defect occurs during the warranty period, this inspection fee will be waived and the problem remedied free of charge.

#### Repairs

If a Yaskawa product is found to be defective due to Yaskawa workmanship or materials and the defect occurs during the warranty period, Yaskawa will provide a replacement, repair the defective product, and provide shipping to and from the site free of charge.

However, if the Yaskawa Authorized Service Center determines that the problem with the drive is not due to defective workmanship or materials, the customer will be responsible for the cost of any necessary repairs. Some problems that are outside the scope of this warranty are:

Problems due to improper maintenance or handling, carelessness, or other reasons where the customer is determined to be responsible.

Problems due to additions or modifications made to a Yaskawa product without Yaskawa's understanding.

Problems due to the use of a Yaskawa product under conditions that do not meet the recommended specifications.

Problems caused by natural disaster or fire.

After the free warranty period elapses.

Replenishment or replacement of consumables or expendables.

Defective products due to packaging or fumigation.

Other problems not due to defects in Yaskawa workmanship or materials.

Warranty service is only applicable within the country where the product was purchased. However, after-sales service is available for customers outside of the country where the product was purchased for a reasonable fee.

Contact your local Yaskawa representative for more information.

#### Exceptions

Any inconvenience to the customer or damage to non-Yaskawa products due to Yaskawa's defective products whether within or outside of the warranty period are NOT covered by warranty.

**This Page Intentionally Blank**



## Receiving

---

This chapter explains how to inspect the Z1000 Bypass upon receipt, and gives an overview of the different enclosure types and components.

<b>1.1</b>	<b>SECTION SAFETY.....</b>	<b>26</b>
<b>1.2</b>	<b>GENERAL DESCRIPTION.....</b>	<b>27</b>
<b>1.3</b>	<b>MODEL NUMBERS AND NAMEPLATE CHECKS.....</b>	<b>28</b>
<b>1.4</b>	<b>BYPASS COMPONENT DESCRIPTIONS.....</b>	<b>31</b>
<b>1.5</b>	<b>BYPASS COMPONENT NAMES.....</b>	<b>33</b>

## 1.1 Section Safety

### NOTICE

**Observe proper electrostatic discharge procedures (ESD) when handling the drive and circuit boards.**

Failure to comply may result in ESD damage to the drive circuitry.

**A motor connected to a PWM drive may operate at a higher temperature than a utility-fed motor and the operating speed range may reduce motor cooling capacity.**

Ensure that the motor is suitable for drive duty and/or the motor service factor is adequate to accommodate the additional heating with the intended operating conditions.

## 1.2 General Description

### ◆ Control Mode Details

*Table 1.1* gives an overview of the various features associated with the Z1000 Bypass.

**Table 1.1 Control Mode Features**

Motor Type	Induction Motors	Comments
Control Mode	V/f	–
Basic Description	V/f control	–
Type of Applications	Motor Type	IM
	Multi Motor	YES
	Motor data unknown	YES
	High Speed Accuracy	–
Control Characteristics	Speed Control Range	1:40 May fluctuate with characteristics and motor temperature.
	Speed Accuracy	±2 to 3% Speed deviation when operating at constant speed may fluctuate with characteristics and motor temperature.
	Speed Response	3 Hz (approx.) Max. frequency of a speed reference signal that the drive can follow may fluctuate with characteristics and motor temperature.
	Starting Torque	140% at 3 Hz Starting torque may fluctuate with characteristics and motor temperature. Performance may differ by capacity.
Application-Specific	Auto-Tuning	<ul style="list-style-type: none"> <li>Energy Saving Tuning</li> <li>Line to line resistance</li> </ul> Automatically adjusts parameter settings that concern electrical characteristics of the motor.
	Speed Search	YES Bi-directional speed detection of a coasting motor to restart it without stopping.
	Energy-Saving Control	YES Saves energy by always operating the motor at its maximum efficiency.
	High Slip Braking	YES Increases motor loss to allow for faster deceleration. Effectiveness may vary based on motor characteristics.
	Kinetic Energy Buffering	YES Decelerates the drive to allow it to ride through a momentary power loss and continue operation.
	Overexcitation Deceleration	YES Provides fast deceleration without using a braking resistor.
	Overvoltage Suppression	YES Prevents overvoltage by increasing speed during regeneration.

## 1.3 Model Numbers and Nameplate Checks

Please perform the following tasks after receiving the Z1000 Bypass

- Inspect the Z1000 Bypass for damage.

If the Z1000 Bypass appears damaged upon receipt, contact the shipper immediately.

- Verify receipt of the correct model by checking the information on the nameplate.
- If you have received the wrong model or the Z1000 Bypass does not function properly, contact your supplier.

If you find any irregularities in the above items, contact the shipping company, the distributor or representative you purchased the Z1000 Bypass from or your Yaskawa office immediately. The Z1000 Bypass is thoroughly tested at the factory. Any damages or shortages evident when the equipment is received must be reported immediately to the commercial carrier that transported the material. Shipping damage is not covered by the Yaskawa warranty. After unpacking and inspecting for damage, verify that internal wire connections have not come loose during shipment by spot checking wire terminations with a screwdriver or the appropriate tool. Z1000 Bypass storage must be in a clean and dry location. Maintain the factory packaging and provide covering as needed to protect the Z1000 Bypass from construction site dirt, water, debris and traffic prior to and during construction.

### ◆ Drive Nameplate

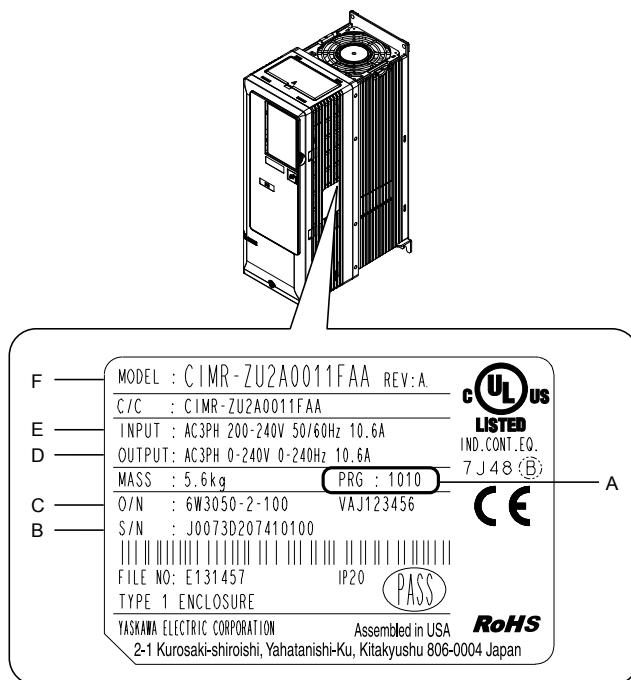

- A – Software version
- B – Serial number
- C – Lot number

- D – Output specifications
- E – Input specifications
- F – AC drive model

Figure 1.1 Drive Nameplate Information Example

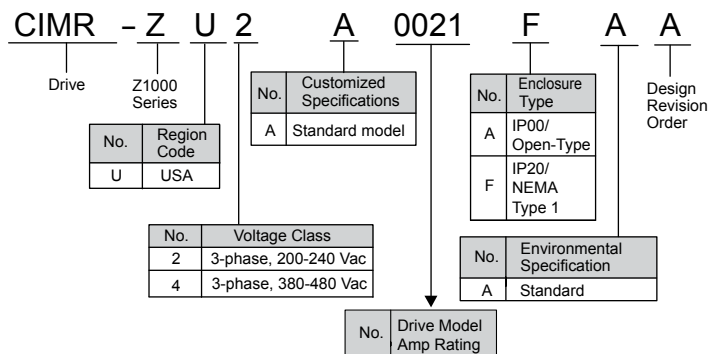

◆ Bypass Nameplate

The nameplate is located on the inside right wall of the Z1000 Bypass enclosure.

The nameplate shown below is an example for a standard Z1000 Bypass.

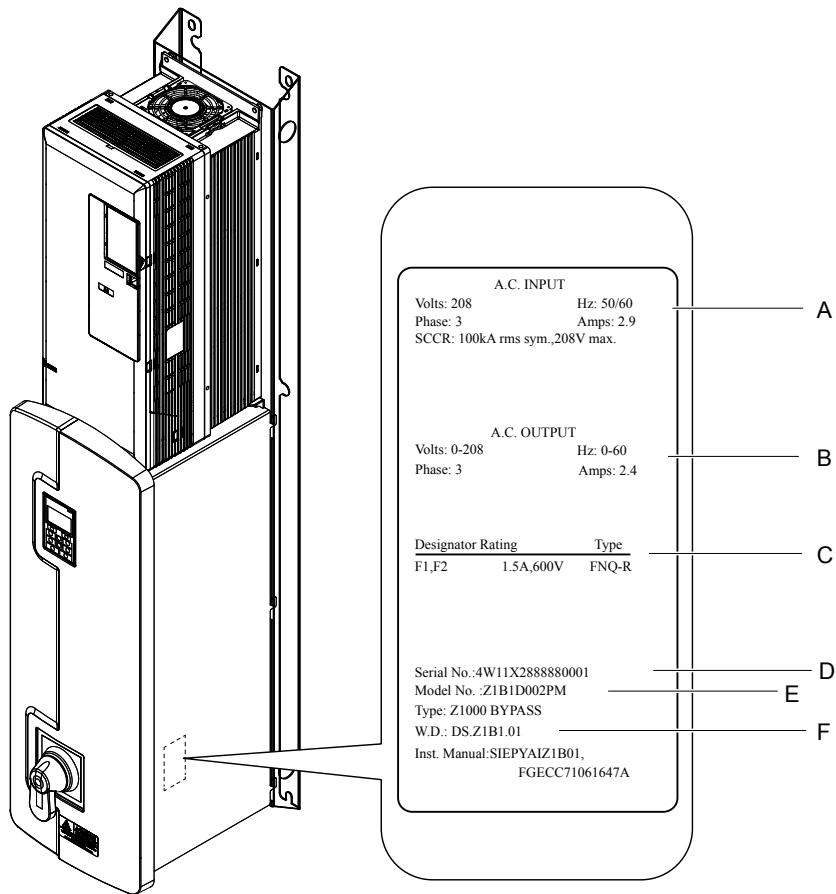

- A – Input specifications
- B – Output specifications
- C – Replacement fuse specifications
- D – Serial number
- E – Bypass model number
- F – Schematic document number

Figure 1.2 Bypass Nameplate Information Example

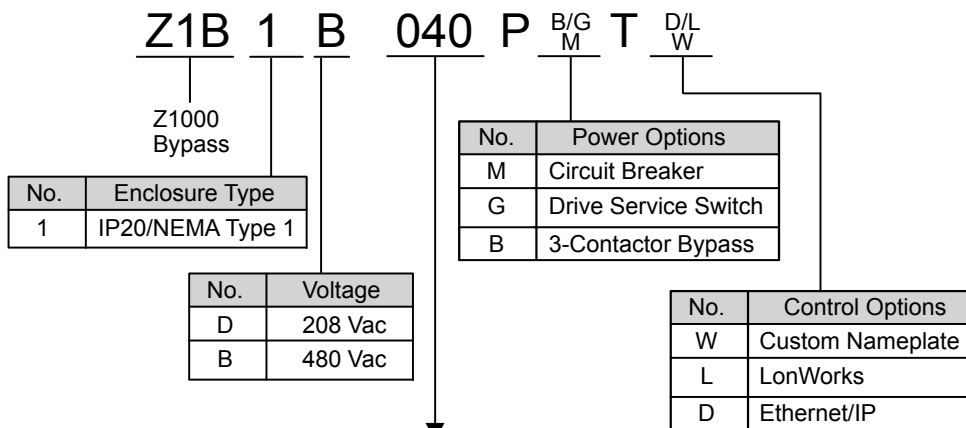

Receiving

1

## 1.3 Model Numbers and Nameplate Checks

### ■ Bypass, Drive Models, and Capacities

Bypass Unit Model Z1B1	Output Capacity			Drive Model CIMR-ZU	Electrical Schematic	Weight (lb)
	HP	Input (A)	Output (A)			
<b>208 Vac</b>						
D002	0.5	2.9	2.4	2A0011	DD.Z1B1.W1.01	45.0
D003	0.75	4.0	3.5			
D004	1	5.1	4.6			
D007	2	8.0	7.5			
D010	3	11.1	10.6			
D016	5	17.2	16.7	2A0017	DD.Z1B1.W2.01	53.0
D024	7.5	24.7	24.2	2A0024		
D030	10	31.3	30.8	2A0031		
D046	15	46.7	46.2	2A0046	DD.Z1B1.W3.01	75.0
D059	20	59.9	59.4	2A0059		
D074	25	75.5	74.8	2A0075	DD.Z1B1.W4.01	128.0
D088	30	88.7	88.0	2A0088	DD.Z1B1.W5.01	243.0
D114	40	114.7	114.0	2A0114		
D143	50	144.4	143.0	2A0143	DD.Z1B1.W6.01	370.0
D169	60	170.4	169.0	2A0169		
D211	75	212.4	211.0	2A0211	DD.Z1.1.F1.02	1050.0
D273	100	274.4	273.0	2A0273		
<b>480 Vac</b>						
B001	0.75	1.8	1.6	4A0005	DD.Z1B1.W1.01	45.0
B002	1	2.3	2.1			
B003	2	3.6	3.4			
B004	3	5.0	4.8			
B007	5	7.8	7.6	4A0008	DD.Z1B1.W2.01	53.0
B011	7.5	11.2	11.0	4A0011		
B014	10	14.2	14.0	4A0014		
B021	15	21.2	21.0	4A0021	DD.Z1B1.W3.01	75.0
B027	20	27.2	27.0	4A0027		
B034	25	34.2	34.0	4A0034	DD.Z1B1.W4.01	128.0
B040	30	40.2	40.0	4A0040		
B52L	40	52.0	52.0	4A0052□□B	DD.Z1B1.W5.01	243.0
B052	40	52.2	52.0	4A0052□□A		
B065	50	65.3	65.0	4A0065	DD.Z1B1.W6.01	370.0
B077	60	77.3	77.0	4A0077		
B096	75	96.3	96.0	4A0096	DD.Z1.1.F1.02	1050.0
B124	100	124.3	124.0	4A0124		
B156	125	156.6	156.0	4A0156	DD.Z1.1.F1.01	1050.0
B180	150	180.6	180.0	4A0180		
B240	200	240.6	240.0	4A0240	DD.Z1.1.F1.01	1050.0
B302	250	302.6	302.0	4A0302		

### ◆ Bypass Enclosures

All Z1000 Bypass units are intended for non-hazardous locations. All Z1000 Bypass units are NEMA Type 1 Enclosures and are constructed for indoor use to provide a degree of protection against incidental contact with enclosed electrical equipment and falling dust or dirt.

### ◆ Bypass Product Options

*Refer to Bypass Options on page 325* for details on available bypass product configuration options.

## 1.4 Bypass Component Descriptions

### ◆ Bypass Front Control Panel

The external appearance and component names of the Z1000 Bypass are shown in *Figure 1.3*.

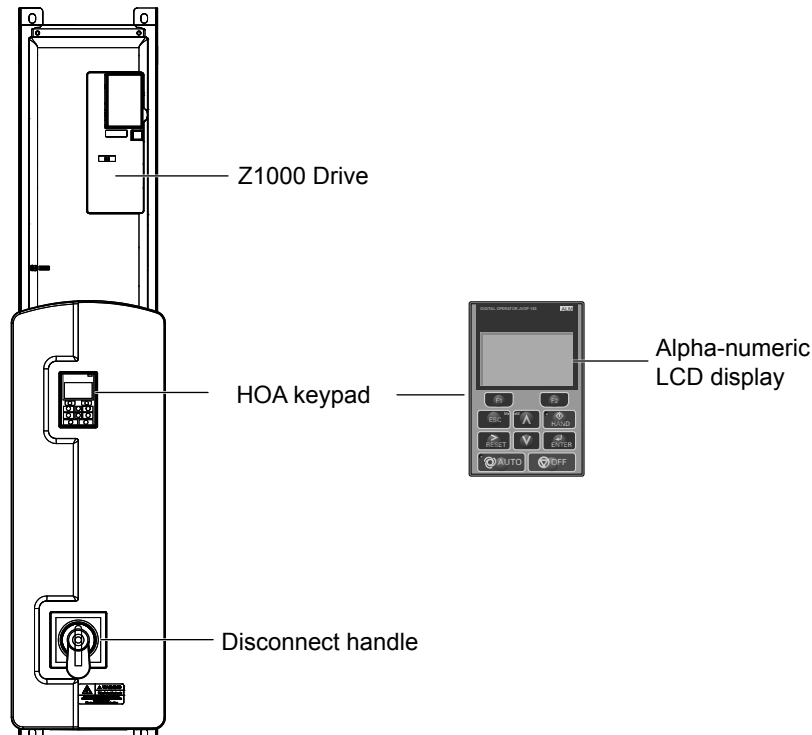

Figure 1.3 Z1000 Bypass Control Panel with Keypad Operator Controls

Refer to *Using the HOA Keypad on page 91* for details on the HOA keypad.

### ■ Input Disconnect Switch

Electrically located on the input power side of the bypass, the door mounted rotary input disconnect switch provides a means of disconnecting the bypass from line power for equipment maintenance. The disconnect must be in the OFF position to open the bypass enclosure door. When opened, the handle can be locked in the OFF position using a padlock.

Branch short circuit protection for the bypass must be supplied by the customer.

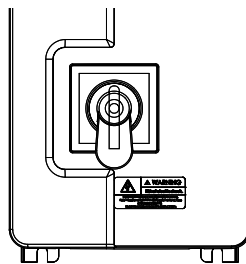

Figure 1.4 Disconnect Handle Shown in the OFF position

### ■ Contactors

The Z1000 Bypass is a 2-contactor or 3-contactor bypass circuit employing IEC rated contactors in an electrically interlocked arrangement to allow mutually exclusive operation in Drive or Bypass modes.

The control logic and “soft start” characteristic of the drive limit the drive input and output contactors to motor FLA current or less. For this reason, the drive output contactor has a lower current rating than the bypass contactor. The bypass contactor is exposed to motor inrush current (LRA) when starting the motor across-the-line and therefore requires a higher current rating.

## 1.4 Bypass Component Descriptions

---

### ■ Overload Relay

The adjustable thermal overload relay (OLR) provides overload protection for the motor in Drive and Bypass operating modes. The bypass three-phase output power connection to the motor is made to the output terminals of the OLR. The OLR is set up in the factory to be a manual reset device, requiring operator attention if an overload trip-out is experienced.

### ■ Control Power Transformer

A Control Power Transformer (CPT) is provided to power the Z1000 Bypass 120 Vac control circuit. The VA capacity is determined by the control circuit and optional functions specified for the unit. The CPT primary is fused in both legs, the secondary is fused when required by NEC (transformer VA and wire size dependent). One side of the transformer secondary is grounded to the bypass enclosure.

### ■ Electronic Bypass Control Logic

Operating elements such as indicating LEDs, selector buttons, and control logic are incorporated into a PCB assembly to eliminate the potential for loose wires after shipment.

The operating elements are located on PCB A3 and the control logic PCB A2 is mounted to the left-hand side of the enclosure and contains the control circuit field wiring terminal blocks TB1 through TB5.

### ■ Drive/Bypass Logic Interlocks

The Z1000 Bypass 120 Vac logic circuit is interconnected with the drive multi-function digital input terminals and multi-function digital output terminals to allow a single customer interface to control both drive and bypass circuits. These drive terminals are not available for field connections. All field control connections are landed at terminal blocks TB1 through TB5 on control logic PCB A2 and drive PCB A1.



## 1.5 Bypass Component Names

This section gives an overview of the Z1000 Bypass components described in this manual.

Note: Refer to *Using the HOA Keypad on page 91* for a description of the HOA keypad.

- 208 Vac Z1B1D002 to D074
- 480 Vac Z1B1B001 to B077

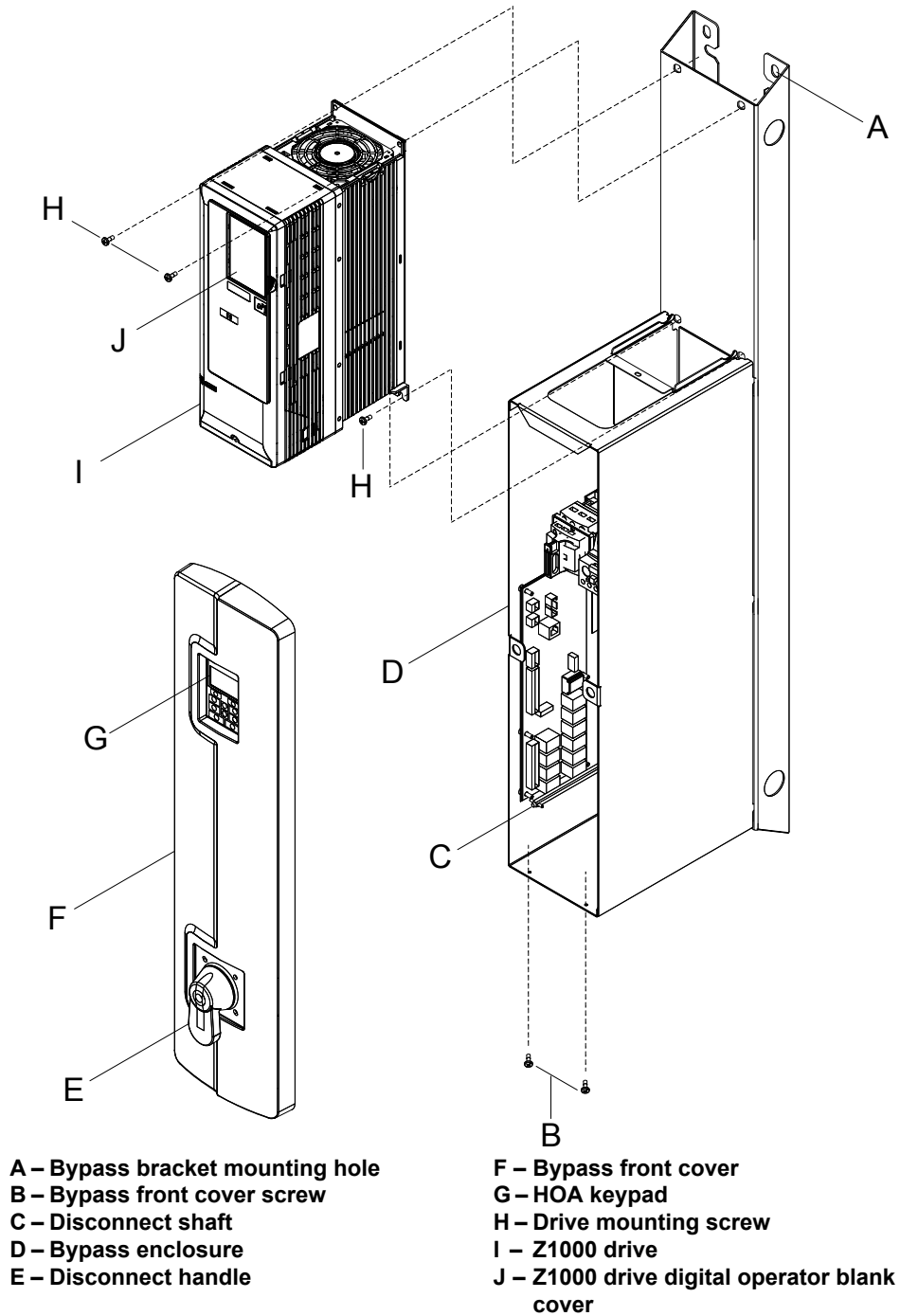
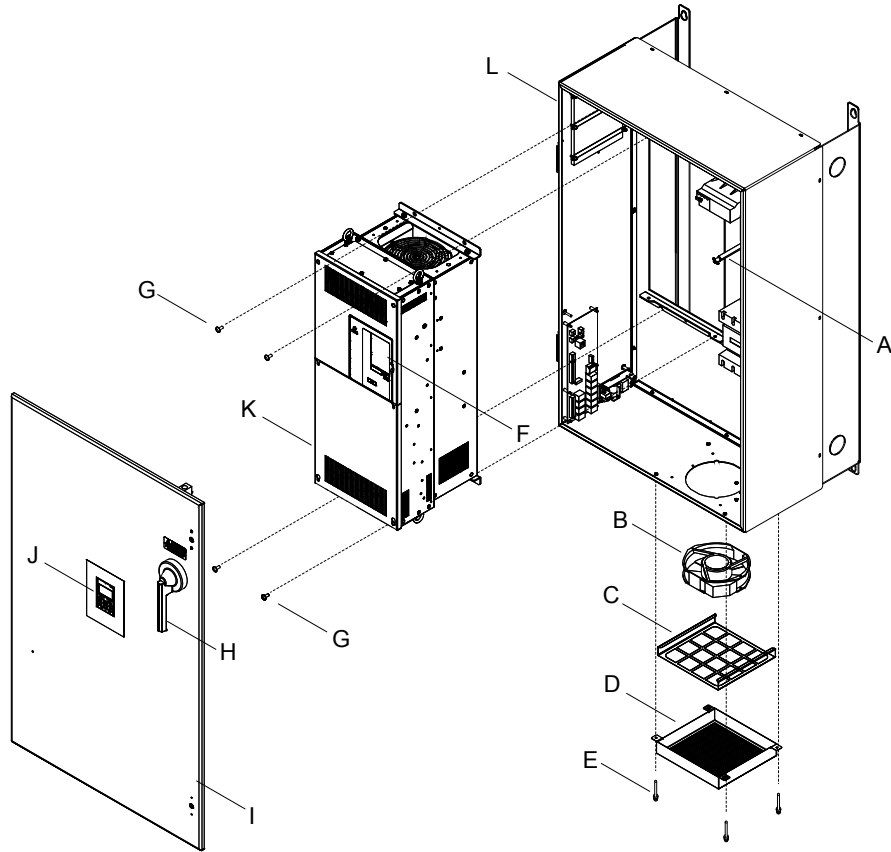

Figure 1.5 Exploded View of Components (Z1B1D002)

## 1.5 Bypass Component Names

- 208 Vac Z1B1D088 to D169
- 480 Vac Z1B1B096 to B180



- |  |                          |
|--|--------------------------|
| A – Disconnect shaft                         | G – Drive mounting screw |
| B – Bypass enclosure fan                     | H – Disconnect handle    |
| C – Fan filter                               | I – Bypass front door    |
| D – Enclosure fan filter                     | J – HOA keypad           |
| E – Fan mounting screws                      | K – Z1000 drive          |
| F – Z1000 drive digital operator blank cover | L – Bypass enclosure     |

Figure 1.6 Exploded View of Components (Z1B1D088)

◆ Front Views

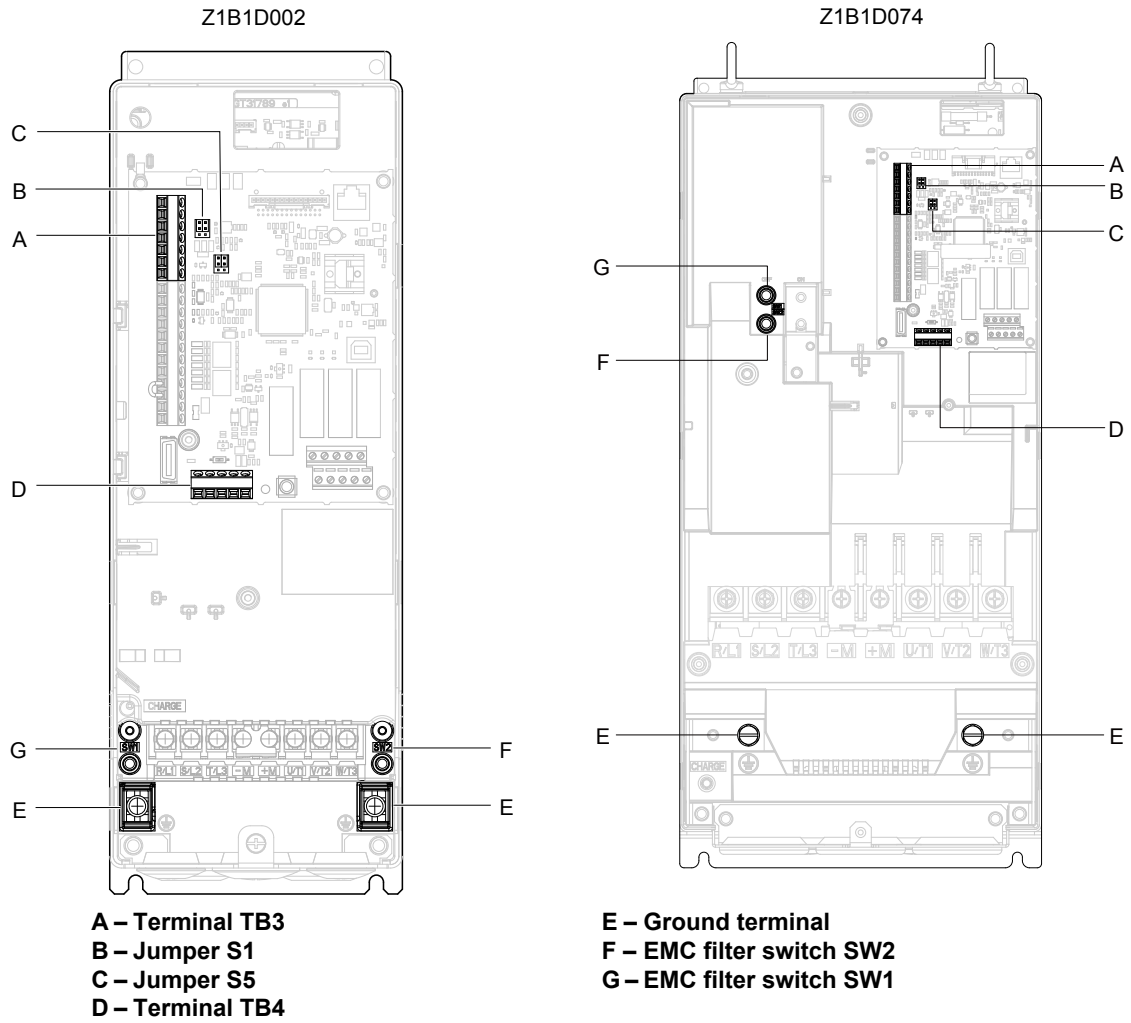
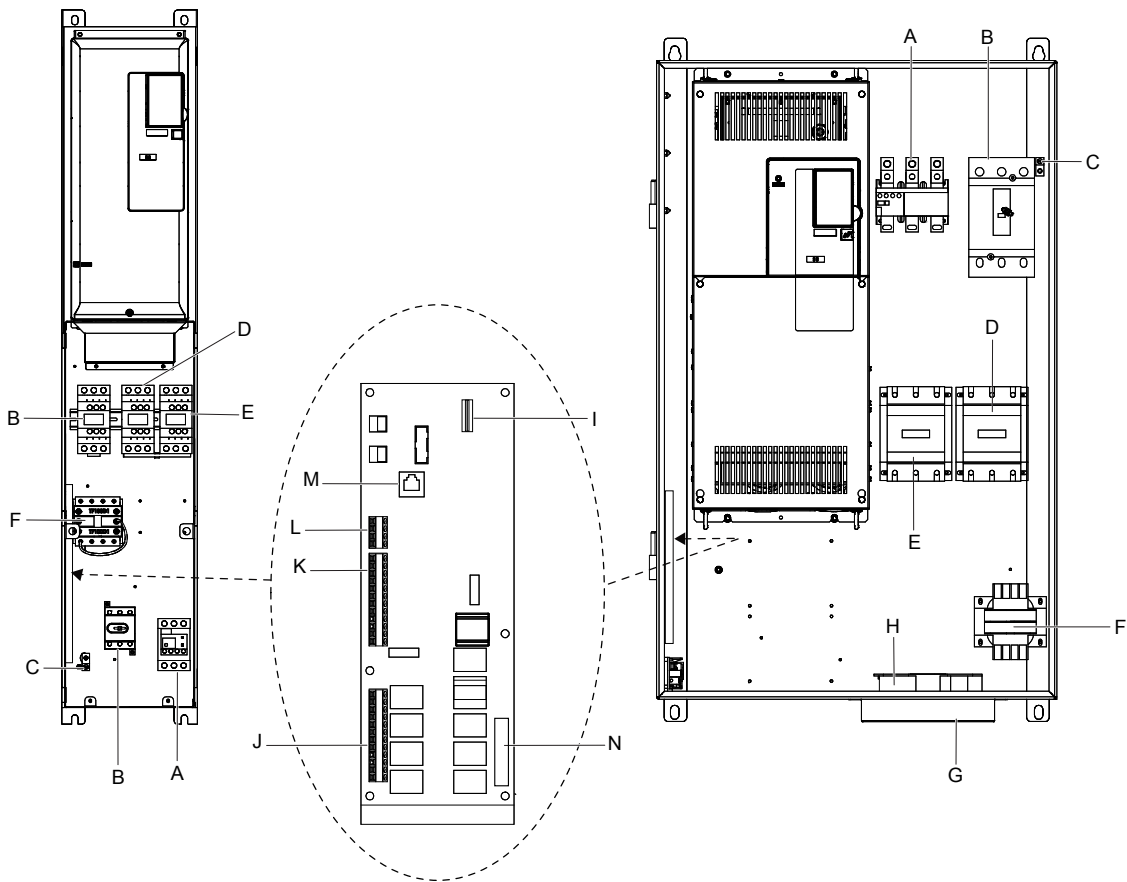

Figure 1.7 Front View of Z1000 Drives

## 1.5 Bypass Component Names



**A – Motor overload**  
**B – Main input disconnect**  
**C – Ground terminal**  
**D – Contactor K2**  
**E – Contactor K3**  
**F – 120 V control transformer**  
**G – Air filter**

**H – Enclosure cooling fan**  
**I – Option card connector CN5**  
**J – Terminal TB1**  
**K – Terminal TB2**  
**L – Terminal TB3**  
**M – Communications port CN2**  
**N – Option B (Contactor K1)**

**Figure 1.8 Front View of Bypass Units**

## Mechanical Installation

---

This chapter explains how to properly mount and install the Z1000 Bypass.

<b>2.1</b>	<b>SECTION SAFETY.....</b>	<b>38</b>
<b>2.2</b>	<b>MECHANICAL INSTALLATION.....</b>	<b>40</b>

## 2.1 Section Safety

### WARNING

#### Crush Hazard

**Use a dedicated lifting device when moving or positioning the drive.**

Failure to comply may result in serious injury or death from falling equipment.

**Use screws to securely affix the drive front cover, terminal blocks, and other drive components prior to vertical suspension.**

Failure to comply may result in serious injury or death from falling equipment.

**Do not subject the drive to vibration or impact greater than 1.96 m/s<sup>2</sup> (0.2 G) while it is suspended by the cables.**

Failure to comply may result in serious injury or death from falling equipment.

**Do not attempt to flip the drive over or leave the drive unattended while it is suspended by the wires.**

Failure to comply may result in serious injury or death from falling equipment.

### CAUTION

#### Crush Hazard

**Do not carry the drive by the front cover or the terminal cover.**

Failure to comply may result in minor or moderate injury from the main body of the drive falling.

### NOTICE

#### Equipment Hazard

**Prevent foreign matter such as metal shavings or wire clippings from falling into the drive during drive installation and project construction.**

Failure to comply could result in damage to the drive. Place a temporary cover over the top during installation. Be sure to remove the temporary cover before start-up, as the cover will reduce ventilation and cause the unit to overheat.

**Observe proper electrostatic discharge (ESD) procedures when handling the drive.**

Failure to comply could result in ESD damage to the drive circuitry.

**Operating the motor in the low-speed range diminishes the cooling effects, increases motor temperature, and may lead to motor damage by overheating.**

Reduce the motor torque in the low-speed range whenever using a standard blower cooled motor. If 100% torque is required continuously at low speed, consider using a special drive or vector-control motor. Select a motor that is compatible with the required load torque and operating speed range.

**The speed range for continuous operation differs according to the lubrication method and motor manufacturer.**

If the motor is to be operated at a speed higher than the rated speed, consult with the manufacturer.

Continuously operating an oil-lubricated motor in the low-speed range may result in burning.

**NOTICE**

**When the input voltage is 480 V or higher or the wiring distance is greater than 100 meters, pay special attention to the motor insulation voltage or use a drive-rated motor with reinforced insulation.**

Failure to comply could lead to motor winding failure.

**Motor vibration may increase when operating a machine in variable-speed mode, if that machine previously operated at a constant speed.**

Install vibration-proof rubber on the motor base or use the frequency jump function to skip a frequency resonating the machine.

**The motor may require more acceleration torque with drive operation than with a commercial power supply.**

Set a proper V/f pattern by checking the load torque characteristics of the machine to be used with the motor.

**The rated input current of submersible motors is higher than the rated input current of standard motors.**

Select an appropriate drive according to its rated output current. When the distance between the motor and drive is long, use a cable thick enough to connect the motor to the drive to prevent motor torque reduction.

**The current rating for a motor with variable pole pitches differs from a standard motor.**

Check the maximum current of the motor before selecting the drive capacity. Only switch motor poles when the motor is stopped. Switching between motor during run will trigger overcurrent protection circuitry or result in overvoltage from regeneration, and the motor will simply coast to stop.

**Never lift or move the drive while the cover is removed.**

This can damage the terminal board and other components.

## 2.2 Mechanical Installation

This section outlines specifications, procedures, and the environment for proper mechanical installation of the bypass.

### ◆ Installation Environment

Install the Z1000 Bypass in an environment matching the conditions below to prolong its optimum performance life.

Move the disconnect handle into the OFF position to open the enclosure door for all bypass units. The wall mount units have two full-turn fasteners, CCW to open, that require a flat blade screwdriver to open the enclosure door.

Wall mount units require a minimum 6 inch clearance above and below to achieve adequate heatsink cooling.

No side clearance is required for cooling because the cooling air flow is in and out of the enclosure door at the front surface of the bypass. To maintain adequate cooling, do not block the enclosure cooling louvers.

**Table 2.1 Installation Environment**

Environment	Conditions
Installation Area	Indoors
Ambient Temperature	-14 to 104 °F (-10 to + 40 °C) NEMA Type 1 Enclosure
Humidity	95% RH or less and free of condensation
Storage Temperature	-20 to +70 °C
Surrounding Area	Install the drive in an area free from: <ul style="list-style-type: none"> <li>• oil mist and dust</li> <li>• metal shavings, oil, water, or other foreign materials</li> <li>• radioactive materials</li> <li>• combustible materials (e.g., wood)</li> <li>• harmful gases and liquids</li> <li>• excessive vibration</li> <li>• chlorides</li> <li>• direct sunlight.</li> </ul>
Altitude	Up to 1000 meters without derating. Up to 3000 meters with output current and voltage derating
Vibration	10 to 20 Hz at 9.8 m/s <sup>2</sup> 20 to 55 Hz at 5.9 m/s <sup>2</sup> (Drive models CIMR-Z□2A0011 to 2A0031 and 4A0005 to 4A0027) or 2.0 m/s <sup>2</sup> (Drive models CIMR-Z□2A0046 to 2A00396 and 4A0034 to 4A0590)
Orientation	Install the bypass vertically to maintain maximum cooling effects.

**NOTICE:** Avoid placing peripheral devices, transformers, or other electronics near the Z1000 Bypass as the noise created can lead to erroneous operation. If such devices must be used in close proximity to the Bypass, take proper steps to shield the bypass from noise.

**NOTICE:** Prevent foreign matter such as metal shavings and wire clippings from falling into the Z1000 Bypass during installation. Failure to comply could result in damage to the bypass. Place a temporary cover over the top of the drive during installation. Remove the temporary cover before bypass start-up, as the cover will reduce ventilation and cause the Bypass to overheat.



### ◆ Installation Orientation and Spacing

Install the Z1000 Bypass upright as illustrated in *Figure 2.1* to maintain proper cooling.

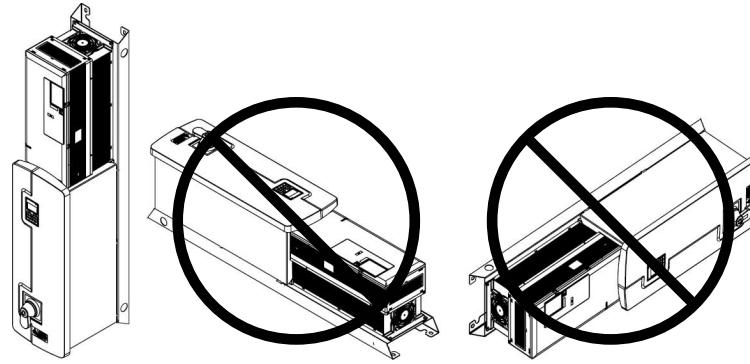

Figure 2.1 Correct Installation Orientation

### ■ Single Bypass Installation

*Figure 2.2* shows the installation distance required to maintain sufficient space for airflow and wiring. Install the heatsink against a closed surface to avoid diverting cooling air around the heatsink.

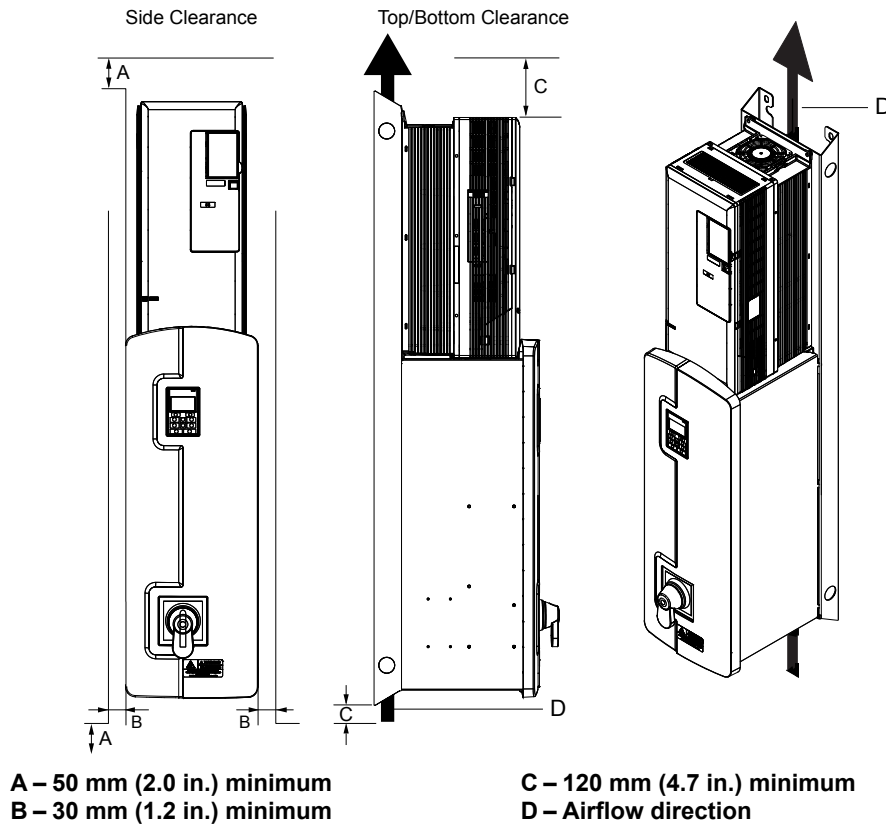

Figure 2.2 Correct Installation Spacing

### ◆ Exterior and Mounting Dimensions

Table 2.2 Bypass Dimensions by Model

Bypass Unit Model Z1B1		Page
208 Vac	480 Vac	
D002 D003 D004 D007 D010 D016	B001 B002 B003 B004 B007 B011	43
D024 D030	B014 B021 B027	
D046 D059	B034 B040 B52L	
D074	B052 B065 B077	
D088 D114	B096 B124	45
D143 D169	B156 B180	
D211 D273	B240 B302	47

■ 208 Vac (Z1B1D002 to D074)  
 480 Vac (Z1B1B001 to B077)

Note: Removing the top protective cover from a NEMA Type 1 enclosure drive voids NEMA Type 1 protection.

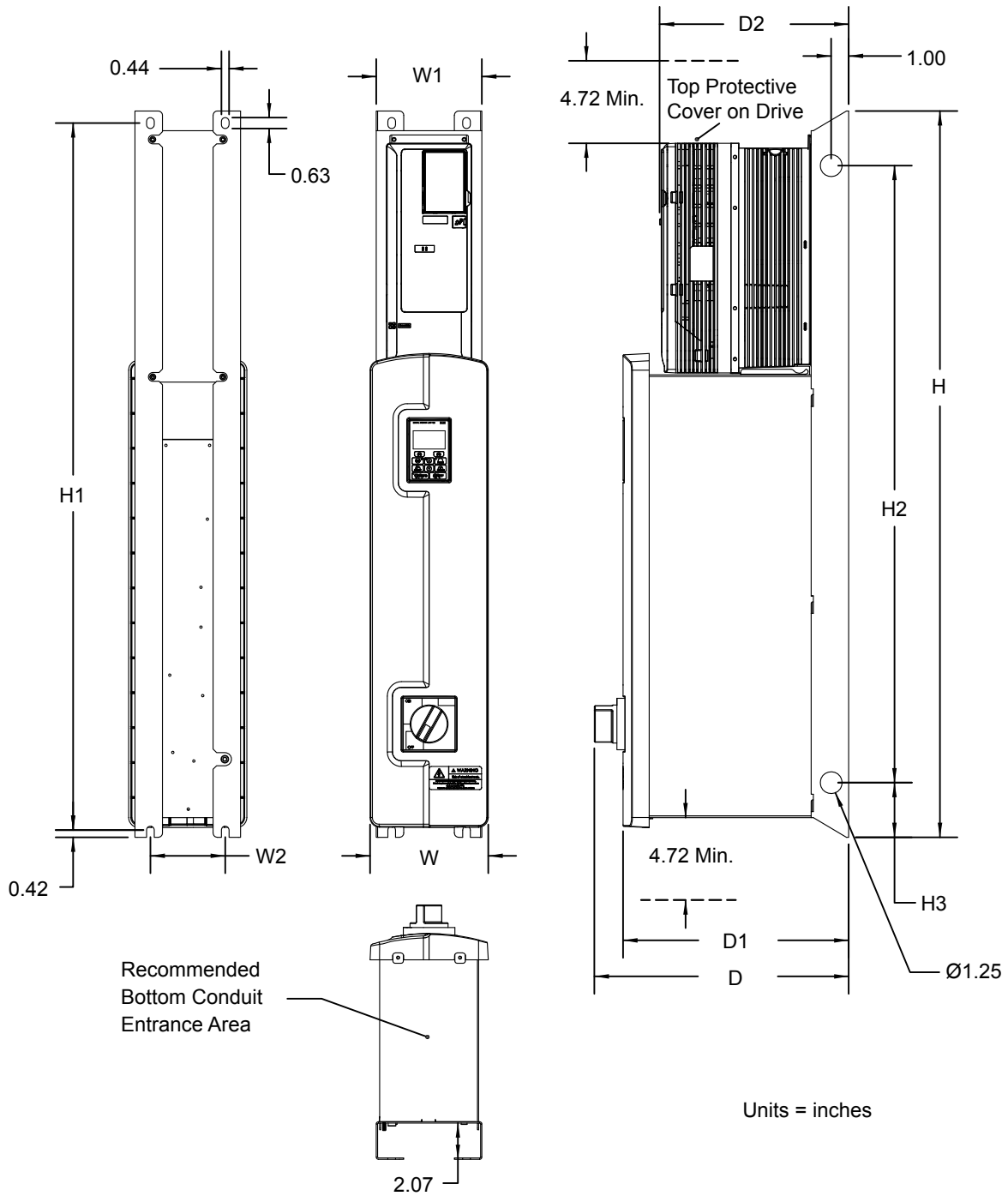

## 2.2 Mechanical Installation

**Table 2.3 Bypass Model Enclosure Dimensions: 208 Vac**

Bypass Model Z1B1 <1>	Dimensions (in)										Wt. (lb)
	W	H	D	W1	W2	H1	H2	H3	D1	D2	
D002	6.77	41.60	14.56	6.05	4.29	40.49	35.34	3.13	12.92	10.83	45.0
D003	6.77	41.60	14.56	6.05	4.29	40.49	35.34	3.13	12.92	10.83	45.0
D004	6.77	41.60	14.56	6.05	4.29	40.49	35.34	3.13	12.92	10.83	45.0
D007	6.77	41.60	14.56	6.05	4.29	40.49	35.34	3.13	12.92	10.83	45.0
D010	6.77	41.60	14.56	6.05	4.29	40.49	35.34	3.13	12.92	10.83	45.0
D016	6.77	41.60	14.56	6.05	4.29	40.49	35.34	3.13	12.92	10.83	45.0
D024	6.77	45.10	14.56	6.05	4.29	43.99	38.84	3.13	12.92	11.42	53.0
D030	6.77	45.10	14.56	6.05	4.29	43.99	38.84	3.13	12.92	11.42	53.0
D046	10.18	48.20	15.43	9.15	7.39	47.09	41.94	3.13	13.19	11.48	75.0
D059	10.18	48.20	15.43	9.15	7.39	47.09	41.94	3.13	13.19	11.48	75.0
D074	12.68	52.80	16.44	11.65	9.89	51.69	35.50	14.17	14.20	12.52	128.0

<1> Removing the top protective cover from a NEMA Type 1 drive voids the NEMA Type 1 protection.

**Table 2.4 Bypass Model Enclosure Dimensions: 480 Vac**

Bypass Model Z1B1 <1>	Dimensions (in)										Wt. (lb)
	W	H	D	W1	W2	H1	H2	H3	D1	D2	
B001	6.77	41.60	14.56	6.05	4.29	40.49	35.34	3.13	12.92	10.83	45.0
B002	6.77	41.60	14.56	6.05	4.29	40.49	35.34	3.13	12.92	10.83	45.0
B003	6.77	41.60	14.56	6.05	4.29	40.49	35.34	3.13	12.92	10.83	45.0
B004	6.77	41.60	14.56	6.05	4.29	40.49	35.34	3.13	12.92	10.83	45.0
B007	6.77	41.60	14.56	6.05	4.29	40.49	35.34	3.13	12.92	10.83	45.0
B011	6.77	41.60	14.56	6.05	4.29	40.49	35.34	3.13	12.92	10.83	45.0
B014	6.77	45.10	14.56	6.05	4.29	43.99	38.84	3.13	12.92	11.42	53.0
B021	6.77	45.10	14.56	6.05	4.29	43.99	38.84	3.13	12.92	11.42	53.0
B027	6.77	45.10	14.56	6.05	4.29	43.99	38.84	3.13	12.92	11.42	53.0
B034	10.18	48.20	15.43	9.15	7.39	47.09	41.94	3.13	13.19	11.48	75.0
B040	10.18	48.20	15.43	9.15	7.39	47.09	41.94	3.13	13.19	11.48	75.0
B52L	10.18	48.20	15.43	9.15	7.39	47.09	41.94	3.13	13.19	11.48	75.0
B052	12.68	52.80	16.44	11.65	9.89	51.69	35.50	14.17	14.20	12.52	128.0
B065	12.68	52.80	16.44	11.65	9.89	51.69	35.50	14.17	14.20	12.52	128.0
B077	12.68	52.80	16.44	11.65	9.89	51.69	35.50	14.17	14.20	12.52	128.0

<1> Removing the top protective cover from a NEMA Type 1 drive voids the NEMA Type 1 protection.

- 208 Vac (Z1B1D088 to D169)
- 480 Vac (Z1B1B096 to B180)

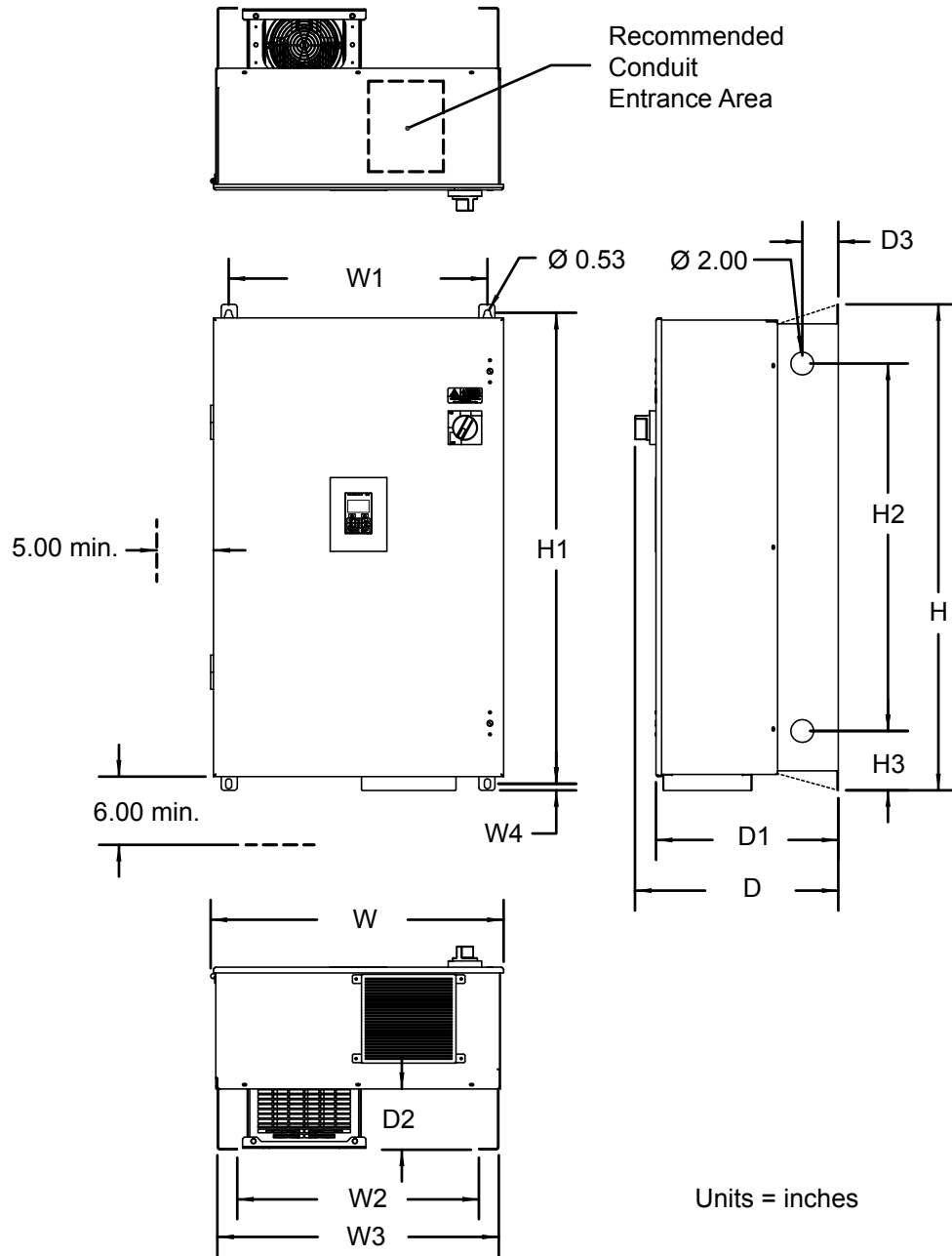

## 2.2 Mechanical Installation

**Table 2.5 Bypass Model Enclosure Dimensions: 208 Vac**

Bypass Model Z1B1	Dimensions (in)													Wt. (lb)
	W	H	D	W1	W2	W3	W4	H1	H2	H3	D1	D2	D3	
D088	25.80	42.79	17.90	22.79	21.29	24.79	0.58	41.46	32.36	5.22	16.06	5.35	3.18	243.0
D114	25.80	42.79	17.90	22.79	21.29	24.79	0.58	41.46	32.36	5.22	16.06	5.35	3.18	243.0
D143	28.41	49.09	20.87	25.09	23.49	27.49	1.05	47.26	36.85	7.70	19.03	6.14	3.39	370.0
D169	28.41	49.09	20.87	25.09	23.49	27.49	1.05	47.26	36.85	7.70	19.03	6.14	3.39	370.0

**Table 2.6 Bypass Model Enclosure Dimensions: 480 Vac**

Bypass Model Z1B1	Dimensions (in)													Wt. (lb)
	W	H	D	W1	W2	W3	W4	H1	H2	H3	D1	D2	D3	
B096	25.80	42.79	17.90	22.79	21.29	24.79	0.58	41.46	32.36	5.22	16.06	5.35	3.18	243.0
B124	25.80	42.79	17.90	22.79	21.29	24.79	0.58	41.46	32.36	5.22	16.06	5.35	3.18	243.0
B156	28.41	49.09	20.87	25.09	23.49	27.49	1.05	47.26	36.85	7.70	19.03	6.14	3.39	370.0
B180	28.41	49.09	20.87	25.09	23.49	27.49	1.05	47.26	36.85	7.70	19.03	6.14	3.39	370.0

- 208 Vac (Z1B1D211 to D273)
- 480 Vac (Z1B1B240 to B302)

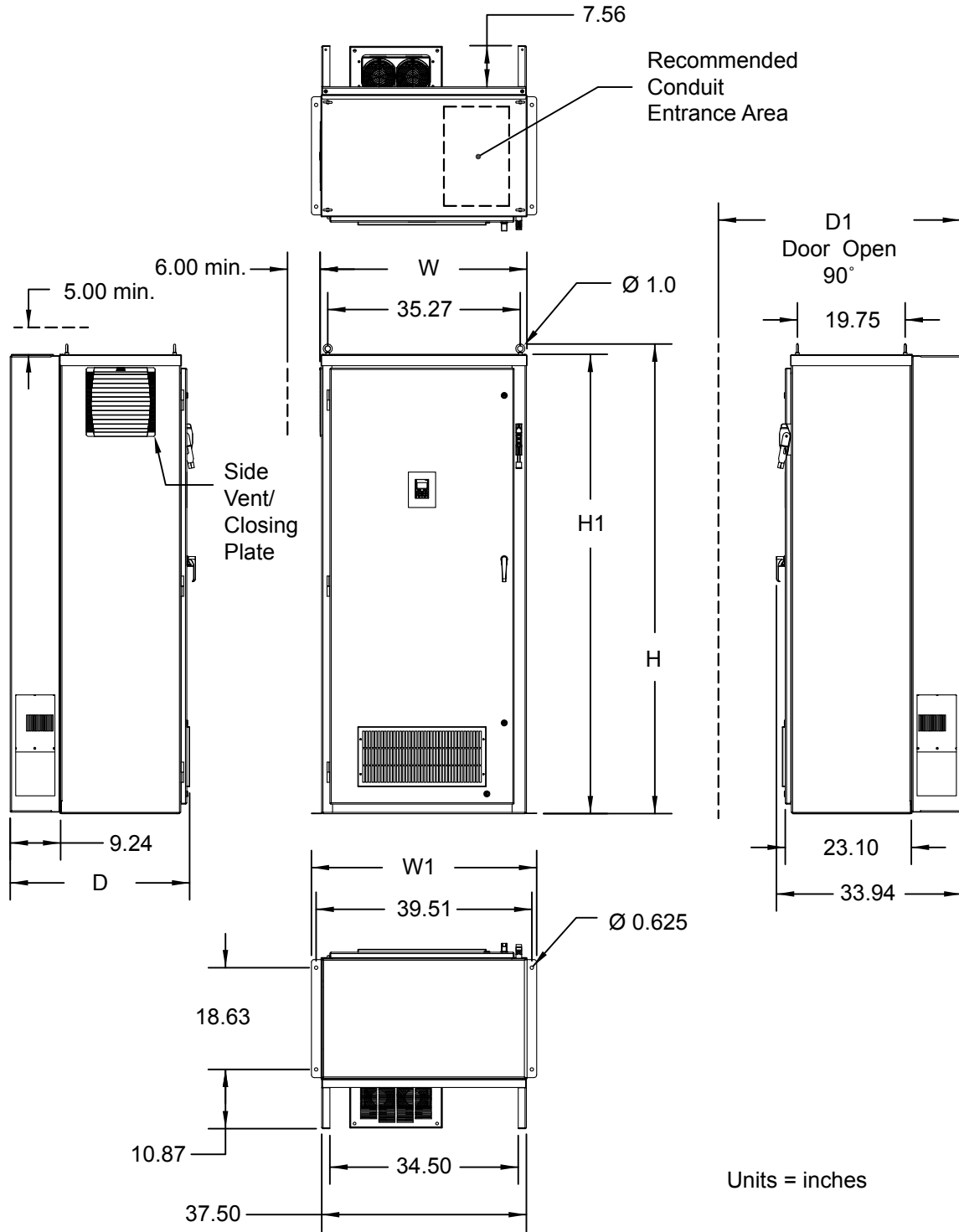

## 2.2 Mechanical Installation

**Table 2.7 Bypass Model Enclosure Dimensions: 208 V**

Bypass Model Z1B1	Dimensions (in)						Wt. (lb)
	W	H	D	W1	H1	D1	
D211	37.93	86.04	32.87	41.26	84.16	65.58	1050.0
D273	37.93	86.04	32.87	41.26	84.16	65.58	1050.0

**Table 2.8 Bypass Model Enclosure Dimensions: 480 V**

Bypass Model Z1B1	Dimensions (in)						Wt. (lb)
	W	H	D	W1	H1	D1	
B240	37.93	86.04	32.87	41.26	84.16	65.58	1050.0
B302	37.93	86.04	32.87	41.26	84.16	65.58	1050.0



# Electrical Installation

---

This chapter explains the proper procedures for wiring the control circuit terminals, motor, and power supply.

<b>3.1</b>	<b>SECTION SAFETY.....</b>	<b>50</b>
<b>3.2</b>	<b>STANDARD CONNECTION DIAGRAM.....</b>	<b>52</b>
<b>3.3</b>	<b>MAIN CIRCUIT WIRING.....</b>	<b>56</b>
<b>3.4</b>	<b>INPUT AND OUTPUT POWER WIRING CONNECTIONS.....</b>	<b>61</b>
<b>3.5</b>	<b>CONTROL CIRCUIT WIRING.....</b>	<b>70</b>
<b>3.6</b>	<b>BYPASS AND DRIVE CONTROL I/O CONNECTIONS.....</b>	<b>85</b>
<b>3.7</b>	<b>EXTERNAL INTERLOCK.....</b>	<b>86</b>

## 3.1 Section Safety

### WARNING

#### Arc Flash Hazard

**It is possible that there is more than one source of power for equipment.**

Obey the requirements for Electrical Safety in the Workplace and local codes for safe work procedures and applicable personal protective equipment (PPE). Failure to obey can cause serious injury or death.

#### Electrical Shock Hazard

**Do not connect or disconnect wiring while the power is on.**

Failure to comply may result in death or serious injury.

Before servicing, disconnect all power to the equipment. The internal capacitor remains charged even after the power supply is turned off. The charge indicator LED will extinguish when the DC bus voltage is below 50 Vdc. To prevent electric shock, wait for at least the time specified on the warning label, once all indicators are OFF, measure for unsafe voltages to confirm the drive is safe prior to servicing.

**Do not operate equipment with covers removed.**

Failure to comply could result in death or serious injury.

The diagrams in this section may show drives without covers or safety shields to show details. Be sure to reinstall covers or shields before operating the drives and run the drives according to the instructions described in this manual.

**Make sure the protective earthing conductor complies with technical standards and local safety regulations.**

Because the leakage current exceeds 3.5 mA, IEC/EN 61800-5-1 states that either the power supply must be automatically disconnected in case of discontinuity of the protective earthing conductor or a protective earthing conductor with a cross-section of at least 10 mm<sup>2</sup> (Cu) or 16 mm<sup>2</sup> (Al) must be used. Failure to comply may result in death or serious injury.

**Always use appropriate equipment for Ground Fault Circuit Interrupters (GFCIs).**

The drive can cause a residual current with a DC component in the protective earthing conductor. Where a residual current operated protective or monitoring device is used for protection in case of direct or indirect contact, always use a type B GFCI according to IEC/EN 60755.

**Always ground the motor-side grounding terminal.**

Improper equipment grounding could result in death or serious injury by contacting the motor case.

**Do not perform work on the drive while wearing loose clothing, jewelry or without eye protection.**

Failure to comply could result in death or serious injury.

Remove all metal objects such as watches and rings, secure loose clothing, and wear eye protection before beginning work on the drive.

**Do not remove covers or touch circuit boards while the power is on.**

Failure to comply could result in death or serious injury.

**Do not allow unqualified personnel to perform work on the drive.**

Failure to comply could result in death or serious injury.

Installation, maintenance, inspection, and servicing must be performed only by authorized personnel familiar with installation, adjustment, and maintenance of AC drives.

**Do not touch any terminals before the capacitors have fully discharged.**

Failure to comply could result in death or serious injury.

Before servicing, disconnect all power to the equipment. The internal capacitor remains charged even after the power supply is turned off. The charge indicator LED will extinguish when the DC bus voltage is below 50 Vdc. To prevent electric shock, wait for at least the time specified on the warning label, once all indicators are OFF, measure for unsafe voltages to confirm the drive is safe prior to servicing.

**⚠ WARNING****Fire Hazard****Tighten all terminal screws to the specified tightening torque.**

Loose electrical connections could result in death or serious injury by fire due to overheating of electrical connections.

**Do not use improper combustible materials.**

Failure to comply could result in death or serious injury by fire.

Do not install the drive to a combustible surface. Never place combustible materials on the drive.

**Do not use an improper voltage source.**

Failure to comply could result in death or serious injury by fire.

Verify that the rated voltage of the drive matches the voltage of the incoming power supply before applying power.

**Properly handle the HOA keypad battery.**

Improper use of the battery may cause fire by explosion and personal injury.

Correctly install the battery, paying attention to polarity (+/-).

Do not attempt to charge the battery or improperly disassemble the HOA keypad.

**⚠ CAUTION****Do not carry the drive by the front cover or the terminal cover.**

Failure to comply may cause the main body of the drive to fall, resulting in minor or moderate injury.

**NOTICE****Observe proper electrostatic discharge procedures (ESD) when handling the drive and circuit boards.**

Failure to comply may result in ESD damage to the drive circuitry.

**Never connect or disconnect the motor from the drive while the drive is outputting voltage.**

Improper equipment sequencing could result in damage to the drive.

**Do not use unshielded cable for control wiring.**

Failure to comply may cause electrical interference resulting in poor system performance. Use shielded, twisted-pair wires and ground the shield to the ground terminal of the drive.

**Do not allow unqualified personnel to use the product.**

Failure to comply could result in damage to the drive.

**Do not modify the drive circuitry.**

Failure to comply could result in damage to the drive and will void warranty.

Yaskawa is not responsible for any modification of the product made by the user. This product must not be modified.

**Check all the wiring to ensure that all connections are correct after installing the drive and connecting any other devices.**

Failure to comply could result in damage to the drive.

**Do not heat or throw the battery into fire.**

The battery remains in use even when power to the drive has been shut off. Be sure to also remove the battery in the HOA keypad when the drive will be shut off for long periods of time.

A dead battery left inside the HOA keypad may leak and damage the keypad and drive. Be sure to replace the battery with a new one immediately after the expected lifespan has passed or when the “bAT” error is displayed on the HOA keypad.

**Be sure to observe the Perchlorate Best Management Practices (BMPs).**

BMPs apply to primary lithium (manganese dioxide) coin batteries sold or distributed in California. Perchlorate Material-special handling may apply, please refer to: [www.dtsc.ca.gov/hazardouswaste/perchlorate](http://www.dtsc.ca.gov/hazardouswaste/perchlorate).

### 3.2 Standard Connection Diagram

Connect the bypass and peripheral devices as shown in [Figure 3.1](#). It is possible to set and run the bypass via the HOA keypad without connecting digital I/O wiring. This section does not discuss drive operation; [Refer to Start-Up Programming & Operation on page 89](#) for instructions on operating the drive.

**WARNING! Fire Hazard.** Branch Circuit protection is required to be installed according to applicable local codes and the requirements listed on the Z1000 Bypass nameplate. Failure to comply could result in fire and damage to the bypass and drive or injury to personnel. The Z1000 Bypass is suitable for use on a circuit capable of delivering not more than 100,000 RMS symmetrical amperes, 208 Vac and 480 Vac with the circuit breaker option or when protected by class J or class L fuses as specified on the Z1000 Bypass nameplate.

**NOTICE:** When the input voltage is 440 V or higher or the wiring distance is greater than 100 meters, pay special attention to the motor insulation voltage or use a drive duty motor. Failure to comply could lead to motor insulation breakdown.

**NOTICE:** Do not connect AC control circuit ground to drive enclosure. Improper drive grounding can cause control circuit malfunction.

**Note:** The minimum load for relay outputs DO-7, DO-8, DO-9, DO-10, M1-M2, M3-M4, M5-M6, and MA-MB-MC is 10 mA.

**WARNING! Sudden Movement Hazard.** Do not close the wiring for the control circuit unless the multifunction input terminal parameters are properly set. Improper sequencing of run/stop circuitry could result in death or serious injury from moving equipment.

**WARNING! Sudden Movement Hazard.** Ensure start/stop circuits are wired properly and in the correct state before energizing the drive. Failure to comply could result in death or serious injury from moving equipment. When programmed for 3-Wire control, a momentary closure on terminal S1 may cause the drive to start.

**WARNING! Sudden Movement Hazard.** When using a 3-Wire sequence, set the drive to 3-Wire sequence prior to wiring the control terminals and set parameter b1-17 to 0 so the drive will not accept a Run command at power up (default). If the drive is wired for a 3-Wire sequence but set up for a 2-Wire sequence (default), and parameter b1-17 is set to 1 so the drive accepts a Run command at power up, the motor will rotate in reverse direction at drive power up and may cause injury.

**WARNING! Sudden Movement Hazard.** Confirm the drive I/O signals and external sequence before executing the application preset function. Executing the application preset function or setting A1-06  $\neq$  0 will change the drive I/O terminal functions and may cause unexpected equipment operation. Failure to comply may cause death or serious injury.

**NOTICE:** When using the automatic fault restart function with wiring designed to shut off the power supply upon drive fault, make sure the drive does not trigger a fault output during fault restart (L5-02 = 0, default). Failure to comply will prevent the automatic fault restart function from working properly.

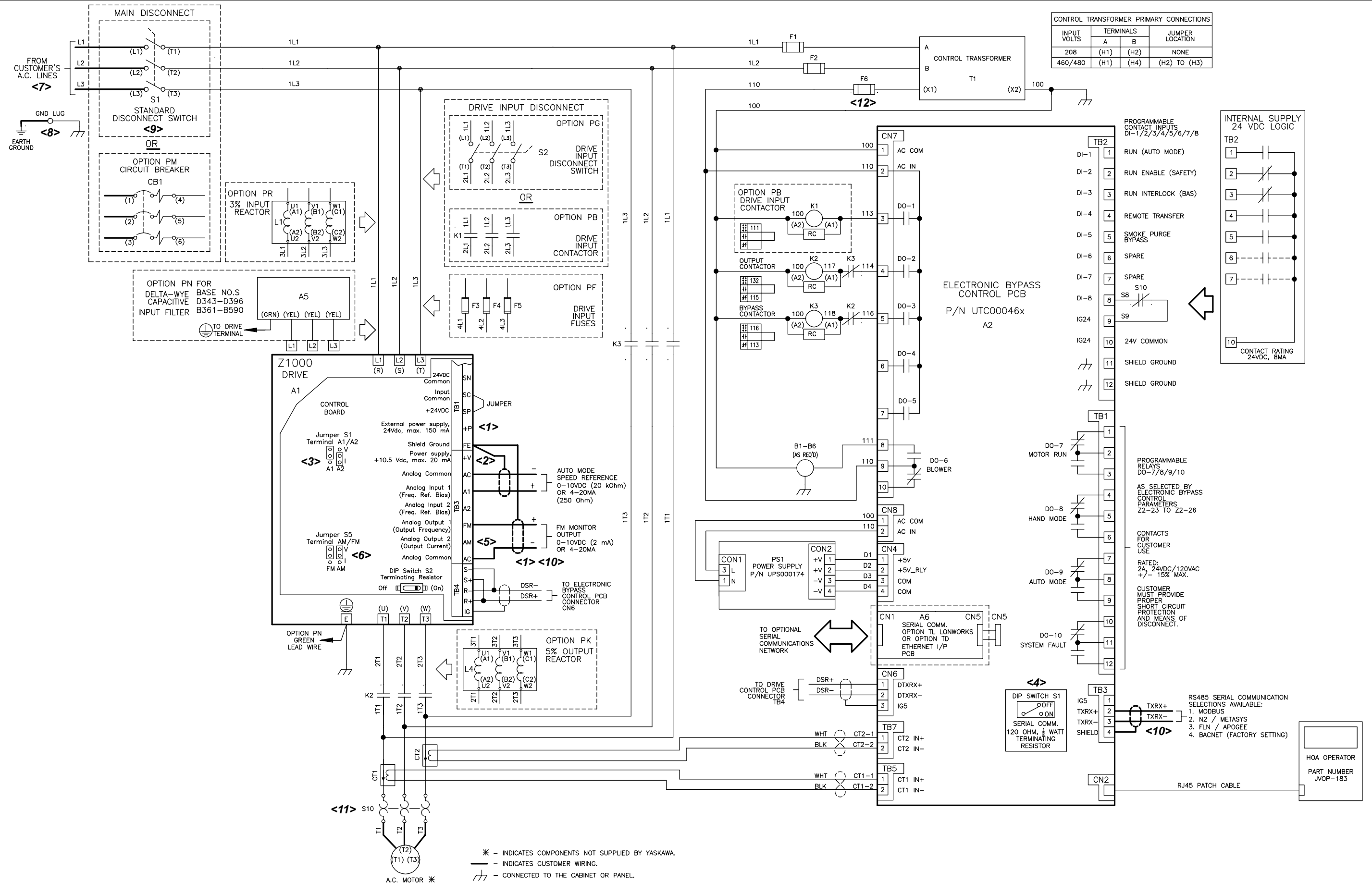

Figure 3.1 Z1000 Bypass Standard Connection Diagram



- <1> This voltage source supplies a maximum current of 150 mA on control board A1.
- <2> The maximum output current capacity for the +V terminal on the control circuit is 20 mA. Never short terminals +V and AC, as it can cause erroneous operation or damage the drive.
- <3> Use jumper S1 to select between a voltage or current input signal to terminals A1 and A2. The default setting is for voltage input.
- <4> Set DIP switch S1 to the ON position to enable the termination resistor in the last drive in a MEMOBUS/Modbus network.
- <5> Monitor outputs work with devices such as analog frequency meters, ammeters, voltmeters, and wattmeters. They are not intended for use as a feedback-type signal.
- <6> Use jumper S5 to select between voltage or current output signals at terminals FM and AM. Set parameters H4-07 and H4-08 accordingly.
- <7> Set E1-01 and E1-05 to 208 for 208 Vac applications.
- <8> Connect the cabinet ground lug to earth ground.
- <9> Branch circuit protection must be supplied by the installer when no input circuit breaker option PM or when noted on the cabinet data nameplate.
- <10> Insulated twisted shielded wire is required. Connect the shield only at this end and stub and isolate the other end. Do not run these wires in the same conduit as AC power or AC control wires.
- <11> The motor overload relay is factory set for manual reset. Adjust the motor overload relay trip setting for the actual AC motor full load amps.
- <12> Secondary fuse F6 is added with control transformer T1 or a power rating 350 VA or greater.

## 3.3 Main Circuit Wiring

This section describes the functions, specifications, and procedures required to safely and properly wire the main circuit in the Z1000 Bypass.

**NOTICE:** Do not solder the ends of wire connections to the bypass. Soldered wiring connections can loosen over time. Improper wiring practices could result in malfunction due to loose terminal connections.

**NOTICE:** Do not switch the bypass input to start or stop the motor. Frequently switching the bypass on and off shortens the life of the DC bus charge circuit and the DC bus capacitors, and can cause premature bypass failures. For the full performance life, refrain from switching the bypass on and off more than once every 30 minutes.

### ◆ Removing/Reattaching the Bypass Front Cover

**WARNING! Electrical Shock Hazard.** Do not open the front cover of the bypass while the power is on. Failure to comply may result in death or serious injury. Make sure that the disconnect handle is in the “OFF” position before attempting to open the front cover.

#### ■ Models Z1B1D002 to D074 and Z1B1B001 to B077

1. Turn the disconnect handle to the “OFF” position.

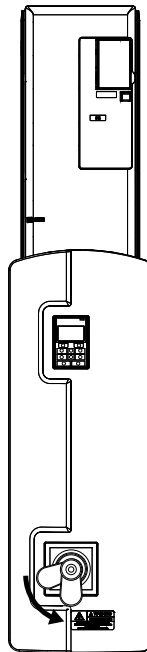

Figure 3.2 Disconnect Power

2. Remove the two front cover screws using a #2 Phillips screwdriver.



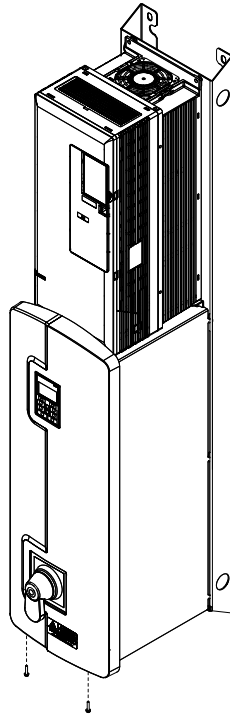

Figure 3.3 Remove Screws

3. Lift the cover up and gently pull forward to remove the front cover.

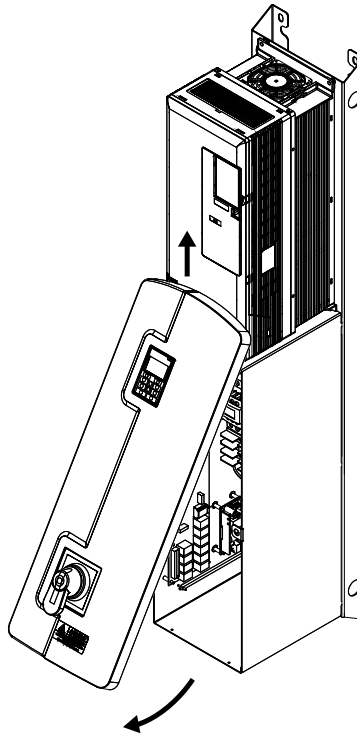

Figure 3.4 Lift and Remove Cover

### 3.3 Main Circuit Wiring

#### ■ Models Z1B1D088 to D273 and Z1B1B096 to B302

1. Turn the disconnect handle to the “OFF” position.

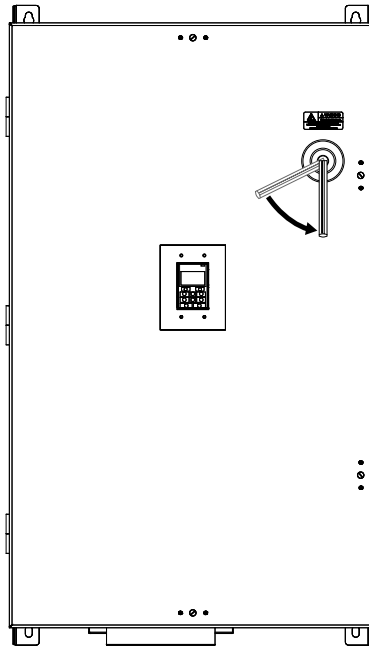

Figure 3.5 Disconnect Power

2. Turn the flat head screw fasteners on the cover 1/2 turn counter-clockwise.

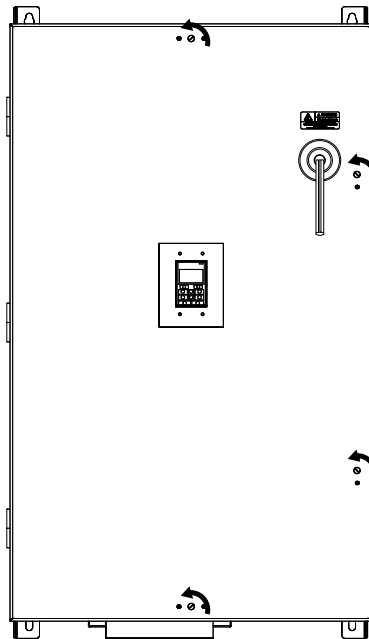

Figure 3.6 Turn Fasteners

3. Door will now swing open on hinges located on left side of the bypass.

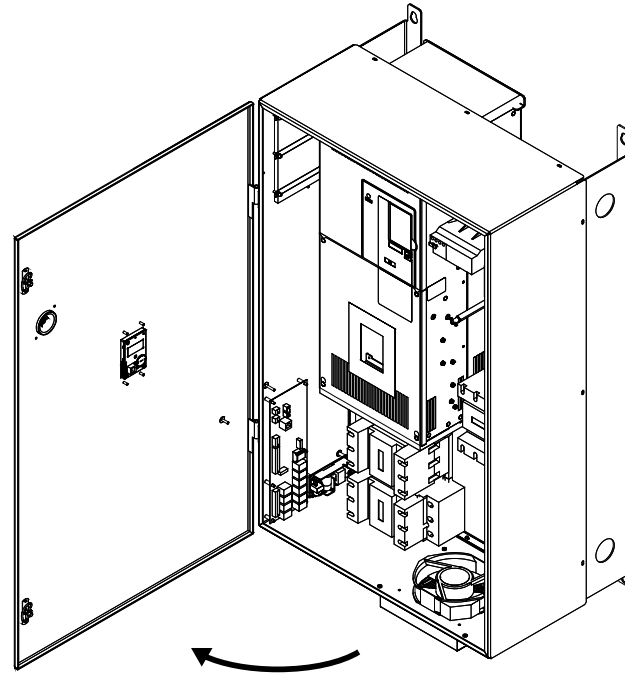

Figure 3.7 Swing Open Door

#### ◆ Bypass Main Circuit Terminal Block Configuration

Figure 3.8 shows the different main circuit terminal arrangements by model.

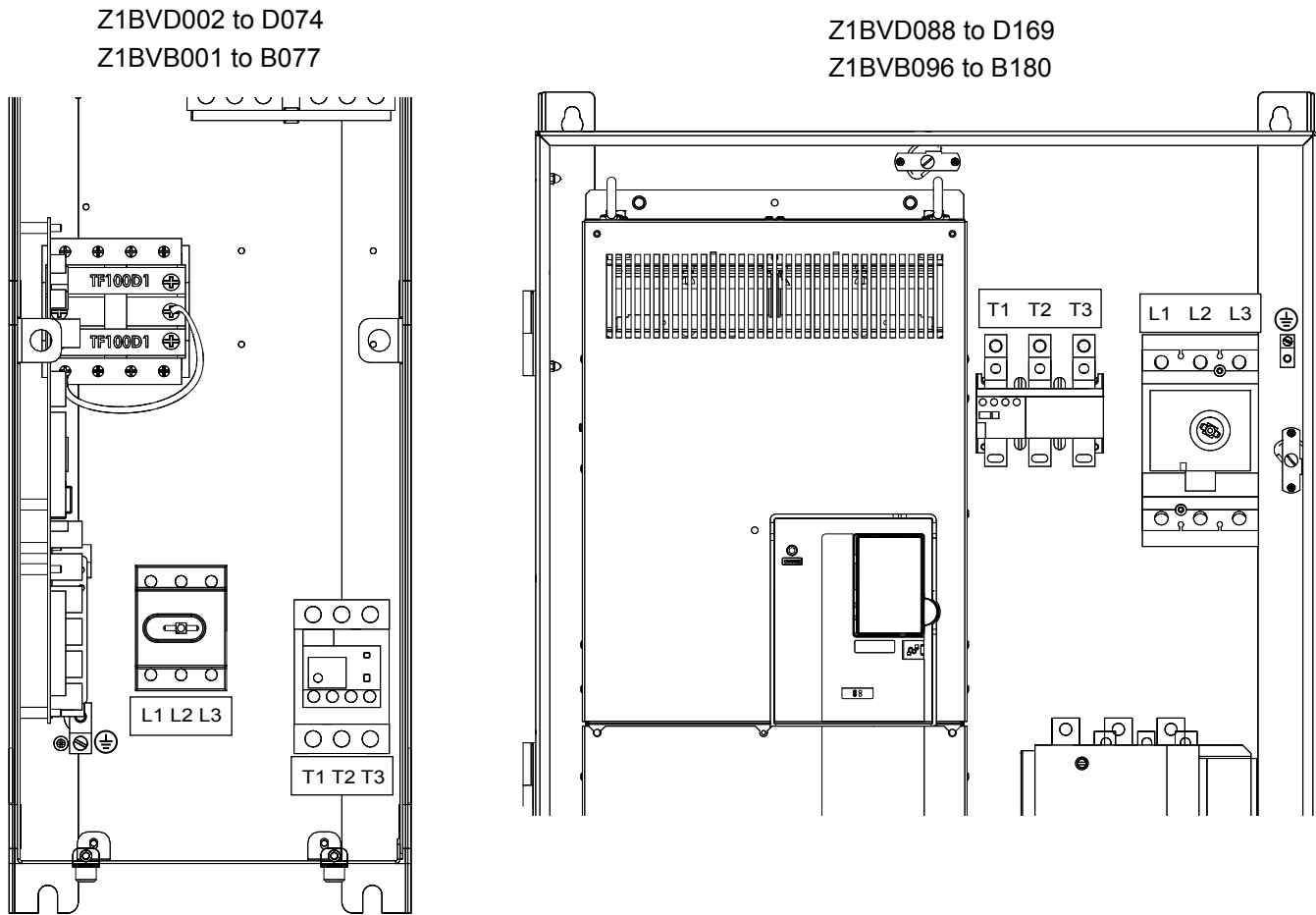
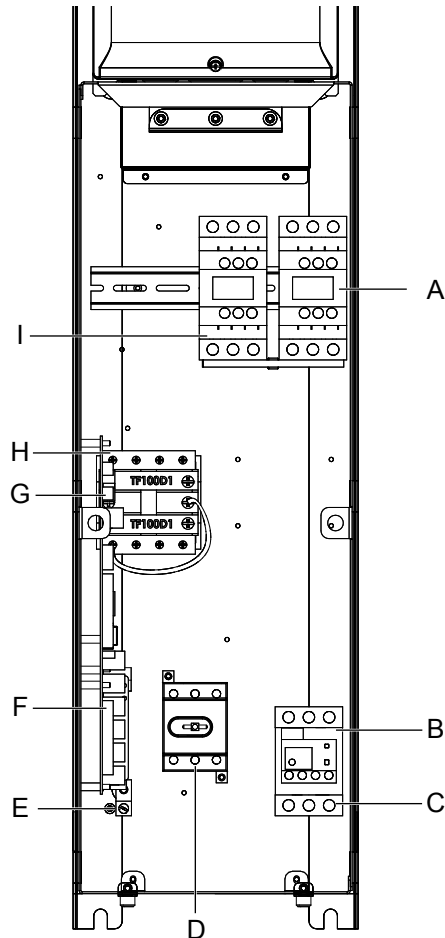

Figure 3.8 Main Circuit Terminal Block Configuration

## 3.4 Input and Output Power Wiring Connections

The input disconnect switch is located in the upper right hand side of the bypass. The three-phase input power connection is made to the input terminals of the disconnect. Refer to [Figure 3.9](#) for a representative example.

The Overload Relay (OLR) is mounted to the contactor assembly or back panel (depending on rating), just above the bypass contactor. The Z1000 Bypass three-phase output power connection to the motor is made to the output terminals of the Overload Relay.



- |                               |                                   |
|-------------------------------|-----------------------------------|
| A – Drive output contactor K2 | F – A2 bypass control board       |
| B – Motor overload relay      | G – 5 V bypass power supply board |
| C – Motor connections         | H – 120 V control transformer     |
| D – Input power terminals     | I – Bypass contactor K3           |
| E – Ground screw              |                                   |

Figure 3.9 Bypass Circuit Components

### ◆ Factory Recommended Branch Circuit Protection

**WARNING! Fire Hazard.** Branch Circuit protection is required to be installed according to applicable local codes and the requirements listed on the Z1000 Bypass nameplate. Failure to comply could result in fire and damage to the bypass and drive or injury to personnel. The Z1000 Bypass is suitable for use on a circuit capable of delivering not more than 100,000 RMS symmetrical amperes, 208 Vac and 480 Vac with the circuit breaker option or when protected by class J or class L fuses as specified on the Z1000 Bypass nameplate.

Yaskawa recommends installing branch circuit protection according to maintain compliance with UL508C. Semiconductor protective type fuses are preferred. Alternate branch circuit protection devices are also listed in this manual.

### 3.4 Input and Output Power Wiring Connections

#### ◆ Main Circuit Terminal Functions

Table 3.1 Main Circuit Terminal Functions

Terminal	Description	Function	Page
R/L1	Main circuit power supply input	Connects line power to the bypass	52
S/L2			
T/L3			
U/T1	Drive output	Connects to the motor	52
V/T2			
W/T3			
⊕	For 208 Vac: 100 Ω or less For 480 Vac: 10 Ω or less	Grounding terminal	64

#### ◆ Wire Gauge and Tightening Torque Specifications

- Note:**
- For 0 to 100 A, use a minimum of 60 °C - 75 °C copper wire.
  - For above 100 A, use a minimum of 75 °C copper wire.
  - Wire gauge recommendations based on drive continuous current ratings using 75 °C 600 Vac vinyl-sheathed wire assuming ambient temperature within 40 °C and wiring distance less than 100 m.

- Consider the amount of voltage drop when selecting wire gauges. Increase the wire gauge when the voltage drop is greater than 2% of motor rated voltage. Ensure the wire gauge is suitable for the terminal block. Use the following formula to calculate the amount of voltage drop:

$$\text{Line drop voltage (V)} = \sqrt{3} \times \text{wire resistance } (\Omega/\text{km}) \times \text{wire length (m)} \times \text{current (A)} \times 10^{-3}$$

- Refer to [UL Standards Compliance on page 459](#) for information on UL compliance.

Table 3.2 Main Input Circuit Wiring Tightening Torques and Wire Gauges

Z1000 Bypass Model Z1B1		With Option PM Circuit Breaker CB1			Standard Non-Fused Input Disconnect Switch S1		
208 Vac	480 Vac	Current Rating (A)	Wire Size Range (AWG)	Tightening Torque (lb. in.)	Current Rating (A)	Wire Size Range (AWG)	Tightening Torque (lb. in.)
D002	B001	30	14-10 or 8-3/0	50 or 120	20	14-8	19
D003	B002						
D004	B003						
D007	B004						
D010	B007						
D016	B011						
–	B014	50	14-10 or 8-3/0	50 or 120	45	12-6	40
–	B021						
D024	B027						
D030	B034	100	14-10 or 8-3/0	50 or 120	63	6-2	50
–	B040						
–	B52L						
D046	B052						
D059	B065	150	14-10 or 8-3/0	50 or 120	100	8-2/0	200
–	B077						
–	B096						
D074	–						
D088	–	250	3/0-350 kcmil	225	150	8-3/0	120
D114	–						
–	B124						
D143	B156	250	3/0-350 kcmil	225	175	4-4/0	225
D169	B180						
		250	3/0-350 kcmil	225	250	3/0-350 kcmil	225

Z1000 Bypass Model Z1B1		With Option PM Circuit Breaker CB1			Standard Non-Fused Input Disconnect Switch S1		
208 Vac	480 Vac	Current Rating (A)	Wire Size Range (AWG)	Tightening Torque (lb. in.)	Current Rating (A)	Wire Size Range (AWG)	Tightening Torque (lb. in.)
D211	–	400	(1-2) x (2/0-500 kcmil)	(1-2) x 442	400	(1-2) x (2/0-500 kcmil)	(1-2) x 442
D273	B240	600	(1-2) x (2/0-500 kcmil)	(1-2) x 442			
–	B302						

Table 3.3 Motor and Ground Wire Gauges and Tightening Torques

Z1000 Bypass Model Z1B1		Output Circuit Motor Wiring		Earth Ground Wiring	
208 Vac	480 Vac	Motor Overload Relay		Ground Lug	
		Wire Size Range (AWG)	Tightening Torque (lb. in.)	Wire Size Range (AWG)	Tightening Torque (lb. in.)
–	B001	18-8	15	14-10 or 8 or 6-4 or 2	35 or 40 or 45 or 50
D002	B002				
D003	B003				
D004	B004				
D007	B007				
D010	B011				
D016	B014				
D024	B021				
D030	B027				
–	B034				
–	B040				
–	B52L				
D046	–				
D059	–				
–	B052	10-1/0	100	14-10 or 8 or 6-4 or 2	35 or 40 or 45 or 50
D074	B065				
–	B077				
D088	B096	6-3/0	200	14-10 or 8 or 6-4 or 2	35 or 40 or 45 or 50
D114	B124				
D143	–				
D169	B156	6-300 kcmil	275	14-10 or 8 or 6-4 or 2	35 or 40 or 45 or 50
–	B180				
D211	B240				
D273	–	(1-2) x (2/0-600 kcmil)	(1-2) x 500	14-2/0	120
–	B302				

### ◆ Main Input Circuit and Motor Wiring

This section outlines the various steps, precautions, and checkpoints for wiring the main circuit terminals and motor terminals.

**WARNING!** *Electrical Shock Hazard. Do not connect the AC power line to the bypass output terminals. Failure to comply could result in death or serious injury by fire as a result of bypass damage from line voltage application to output terminals.*

**NOTICE:** *Route motor leads U/T1, V/T2, and W/T3 separate from all other leads to reduce possible interference related issues. Failure to comply may result in abnormal operation of drive and nearby equipment.*

**NOTICE:** *When connecting the motor to the output terminals T1, T2, and T3, the phase order for the drive and motor should match. Failure to comply with proper wiring practices may cause the motor to run in reverse if the phase order is backward.*

**NOTICE:** *Do not connect phase-advancing capacitors or LC/RC noise filters to the output circuits. Failure to comply could result in damage to the drive, phase-advancing capacitors, LC/RC noise filters or ground fault circuit interrupters.*

## 3.4 Input and Output Power Wiring Connections

### ■ Cable Length Between Bypass and Motor

Voltage drop along the motor cable may cause reduced motor torque when the wiring between the bypass and the motor is too long, especially at low frequency output. This can also be a problem when motors are connected in parallel with a fairly long motor cable. Bypass output current will increase as the leakage current from the cable increases. An increase in leakage current may trigger an overcurrent situation and weaken the accuracy of the current detection.

Adjust the carrier frequency according to [Table 3.4](#). If the motor wiring distance exceeds 100 m because of the system configuration, reduce the ground currents. [Refer to C6-02: Carrier Frequency Selection on page 140](#).

**Table 3.4 Cable Length Between Bypass and Motor**

Cable Length	50 m or less	100 m or less	Greater than 100 m
Carrier Frequency	12.5 kHz or less	5 kHz or less	2 kHz or less

- Note:**
1. When setting carrier frequency for bypasses running multiple motors, calculate cable length as the total wiring distance to all connected motors.
  2. Do not use a long distance shielded line if there is an overvoltage problem at start. Either lower the carrier frequency or switch on the internal EMC filter if the power supply has a neutral ground.

### ■ Ground Wiring

Follow the precautions below when wiring the ground for one bypass or a series of bypasses.

**WARNING! Electrical Shock Hazard.** Do not touch SW1 or SW2 screws while power is applied to the drive. Failure to comply could result in death or serious injury. Before servicing, disconnect all power to the equipment. The internal capacitor remains charged even after the power supply is turned off. The charge indicator LED will extinguish when the DC bus voltage is below 50 Vdc. To prevent electric shock, wait for at least the time specified on the warning label, once all indicators are OFF, measure for unsafe voltages to confirm the drive is safe prior to servicing.

**WARNING! Electrical Shock Hazard.** Make sure the protective earthing conductor complies with technical standards and local safety regulations. Because the leakage current exceeds 3.5 mA, IEC/EN 61800-5-1 states that either the power supply must be automatically disconnected in case of discontinuity of the protective earthing conductor or a protective earthing conductor with a cross-section of at least 10 mm<sup>2</sup> (Cu) or 16 mm<sup>2</sup> (Al) must be used. Failure to comply may result in death or serious injury.

**WARNING! Electrical Shock Hazard.** Always use a ground wire that complies with technical standards on electrical equipment and minimize the length of the ground wire. Improper equipment grounding may cause dangerous electrical potentials on equipment chassis, which could result in death or serious injury.

**WARNING! Electrical Shock Hazard.** Be sure to ground the drive ground terminal (208 Vac: ground to 100 Ω or less and 480 Vac: ground to 10 Ω or less). Improper equipment grounding could result in death or serious injury by contacting ungrounded electrical equipment.

**NOTICE:** Do not share the ground wire with other devices such as welding machines or large-current electrical equipment. Improper equipment grounding could result in drive or equipment malfunction due to electrical interference.

**NOTICE:** When using more than one drive, ground multiple drives according to instructions. Improper equipment grounding could result in abnormal operation of drive or equipment.

Refer to [Figure 3.10](#) when using multiple drives. Do not loop the ground wire.

The drive ground lug (terminal  $\oplus$ ) is connected to the enclosure. The enclosure ground lug must be connected to earth ground. See [Figure 3.9](#).

The drive has a second ground lug to accept the motor ground lead.

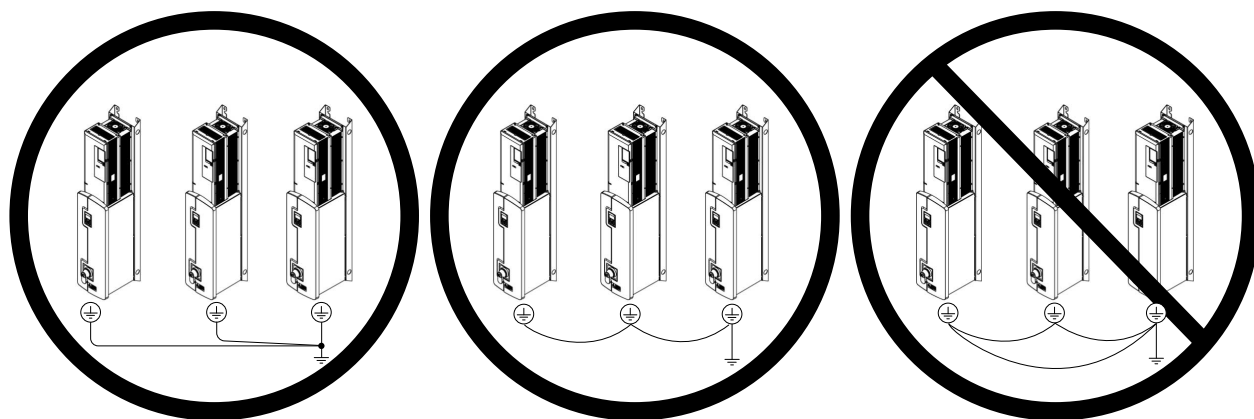

**Figure 3.10 Ground Wiring for Multiple Bypass Units**



■ Enable the Internal EMC Filter

**WARNING!** *Electrical Shock Hazard. Do not touch SW1 or SW2 screws while power is applied to the drive. Failure to comply could result in death or serious injury. Before servicing, disconnect all power to the equipment. The internal capacitor remains charged even after the power supply is turned off. The charge indicator LED will extinguish when the DC bus voltage is below 50 Vdc. To prevent electric shock, wait for at least the time specified on the warning label, once all indicators are OFF, measure for unsafe voltages to confirm the drive is safe prior to servicing.*

**WARNING!** *Electrical Shock Hazard. Connect the ground cable correctly. Failure to comply could result in death or serious injury.*

**NOTICE:** *When disabling the internal EMC filter, move the screws from ON to OFF and then tighten to the specified torque. Completely removing the screws or tightening the screws to an incorrect torque may cause drive failure.*

**NOTICE:** *Keep SW1/SW2 screws positioned together (ON/ON or OFF/OFF). Screws at different positions may cause drive failure.*

**Note:** For floating, impedance grounded, or asymmetrically grounded networks, disconnect the internal EMC filter by moving the SW1/SW2 screws to the OFF position.

**Table 3.5** shows asymmetrical grounded networks. Asymmetrical networks require screws SW1 and SW2 to be in the OFF position. The internal ground connection for the filter is removed when the screws are in the OFF position. (Drives are shipped with SW1 and SW2 screws installed at the OFF position.)

**Table 3.5 Asymmetrical Grounded Network**

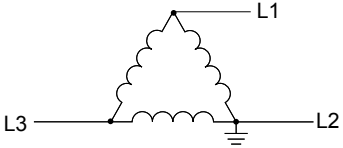
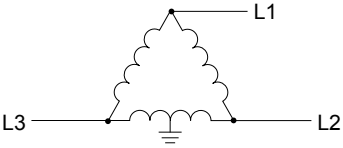
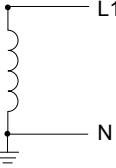
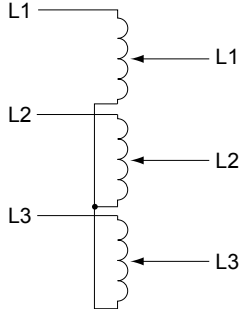
<p>Grounded at the corner of the delta</p>	
<p>Grounded at the middle of the side</p>	
<p>Single-phase, grounded at the end point</p>	
<p>Three-phase variable transformer without solidly grounded neutral</p>	

If EMC is a concern and the network is grounded symmetrically, install the SW1 and SW2 screws to the ON position. Installing the SW1 and SW2 screws enables the internal EMC filter (Drives are shipped with SW1/SW2 screws installed at the OFF position).

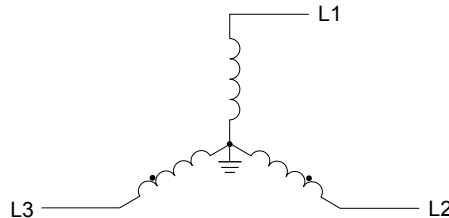

**Figure 3.11 Symmetrical Grounded Network**

### 3.4 Input and Output Power Wiring Connections

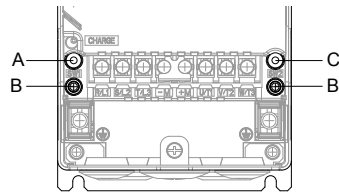

A – SW1 (ON)  
B – Screw (OFF)

C – SW2 (ON)

Figure 3.12 EMC Filter Switch Location (Models Z1B1D002 to D059 and B001 to B52L)

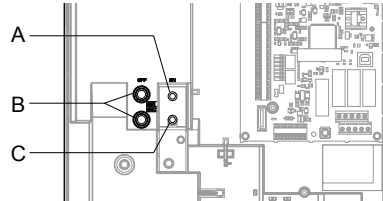

A – SW1 (ON)  
B – Screw (OFF)

C – SW2 (ON)

Figure 3.13 EMC Filter Switch Location (Models Z1B1D074 to D114 and B052 to B096)

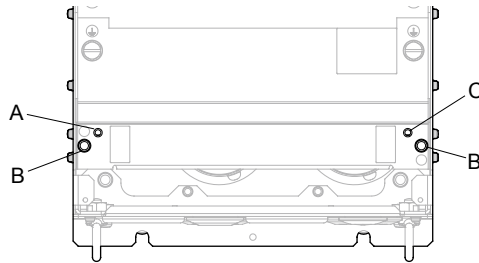

A – SW1 (ON)  
B – Screw (OFF)

C – SW2 (ON)

Figure 3.14 EMC Filter Switch Location (Model Z1B1B124)

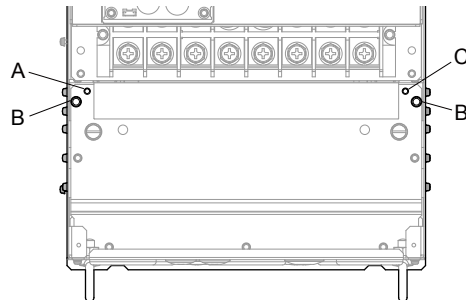

A – SW1 (ON)  
B – Screw (OFF)

C – SW2 (ON)

Figure 3.15 EMC Filter Switch Location (Models Z1B1D143 to D273 and B156 to B240)

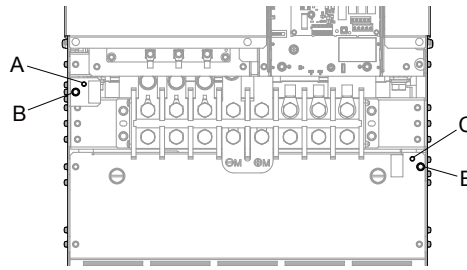

A – SW1 (ON)  
B – Screw (OFF)

C – SW2 (ON)

Figure 3.16 EMC Filter Switch Location (Model Z1B1B302)

If the SW1/SW2 screws are missing, install proper size screws with the proper tightening torque as shown in [Table 3.6](#).

**NOTICE:** Do not use screws of different sizes in SW1 and SW2. Failure to comply may cause overheating.

Table 3.6 SW1/SW2 Screw Sizes and Tightening Torques

Bypass Model Z1B1		SW1/SW2 Screw Size	Tightening Torque
D002 D003 D004 D007 D010 D016	B001 B002 B003 B004 B007 B011	M3 × 16	0.5 to 0.6 N•m
D024 D030	B014 B021 B027	M3 × 16	0.5 to 0.6 N•m
D046 D059	B034 B040 B52L	M3 × 16	0.5 to 0.6 N•m
D074 D088 D114	B052 B065 B077 B096	M5 × 30	2 to 2.5 N•m
–	B124	M5 × 25	2 to 2.5 N•m
D143 D169 D211 D273	B156 B180 B240	M5 × 25	2 to 2.5 N•m
–	B302	M5 × 25	2 to 2.5 N•m

#### ◆ Wiring the Main Input Circuit

**WARNING!** Electrical Shock Hazard. Shut off the power supply to the drive before wiring the main circuit terminals. Failure to comply may result in death or serious injury.

Wire the main circuit terminals after the terminal board has been properly grounded.

### 3.4 Input and Output Power Wiring Connections

#### ■ Main Input Circuit Wire Routing

*Figure 3.17* and *Figure 3.18* show suggested wire entry and bending areas for representative wall mount enclosures.

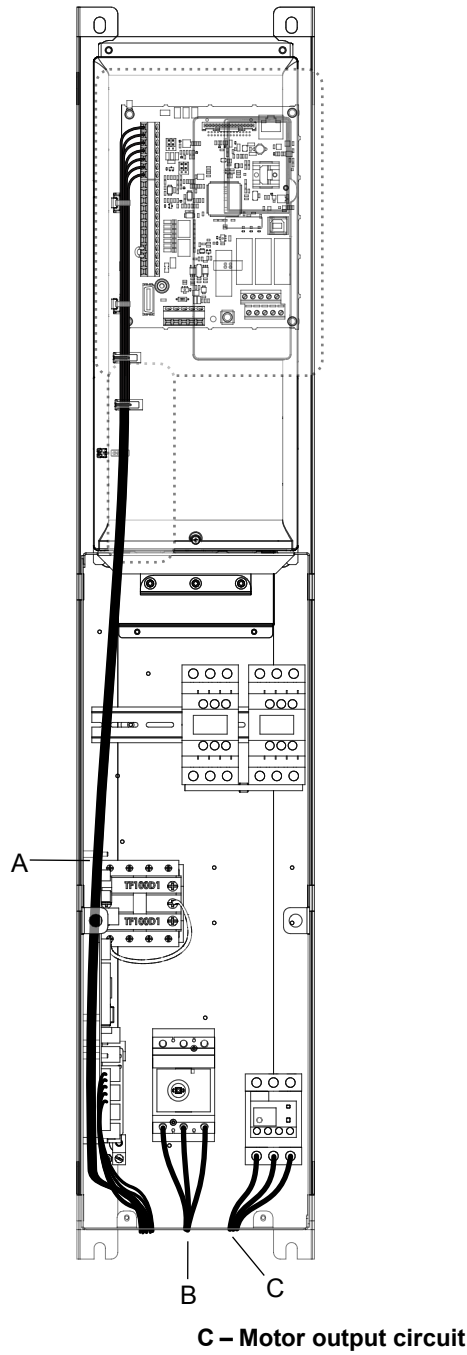

**Figure 3.17 Bypass Wire Routing Example (Models Z1B1D002 to D074 and B001 to B077)**

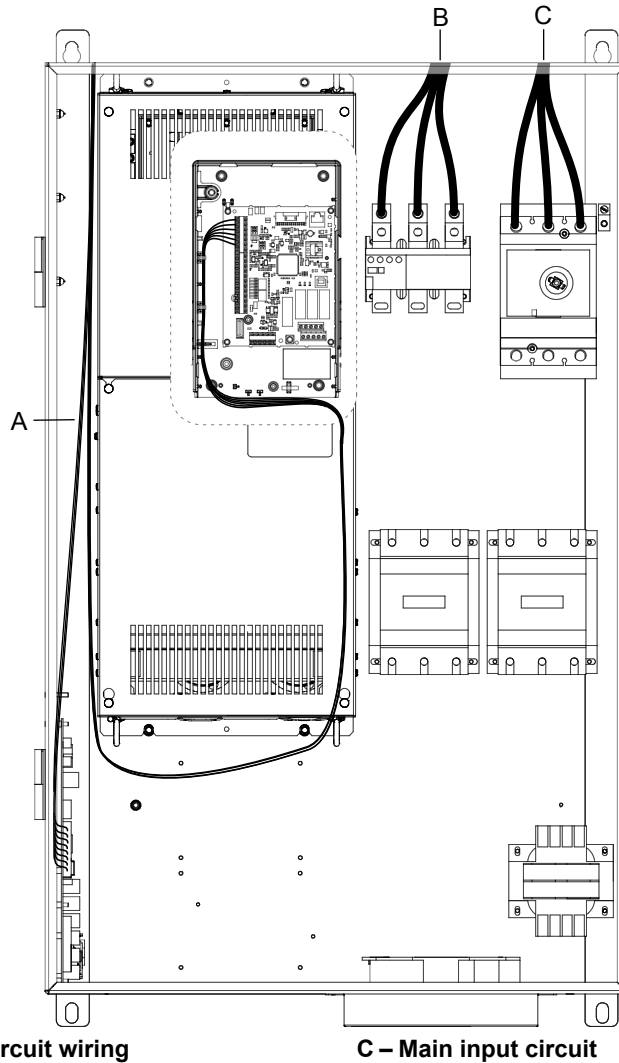

A – Control circuit wiring  
 B – Motor output circuit

C – Main input circuit

Figure 3.18 Bypass Wire Routing Example (Models Z1B1D088 to D273 and B096 to B302)

## 3.5 Control Circuit Wiring

### ◆ Control Circuit Connection Diagram

Refer to [Figure 3.1](#) on page 53 when wiring terminals on the Z1000 Bypass and drive control circuits.

### ◆ Control Circuit Terminal Block Functions

**WARNING! Sudden Movement Hazard.** Always check the operation and wiring of control circuits after being wired. Operating a Z1000 Bypass with untested control circuits could result in death or serious injury.

**WARNING! Sudden Movement Hazard.** Confirm the drive I/O signals and external sequence before starting test run. Setting parameter Z1-01 may change the I/O terminal function automatically from the default setting. Refer to [Application Selection on page 108](#). Failure to comply may result in death or serious injury.

The functions of the control circuit terminals are shown in [Table 3.7](#).

The control circuit terminals on Terminal Board A2 are arranged as shown in [Figure 3.19](#).

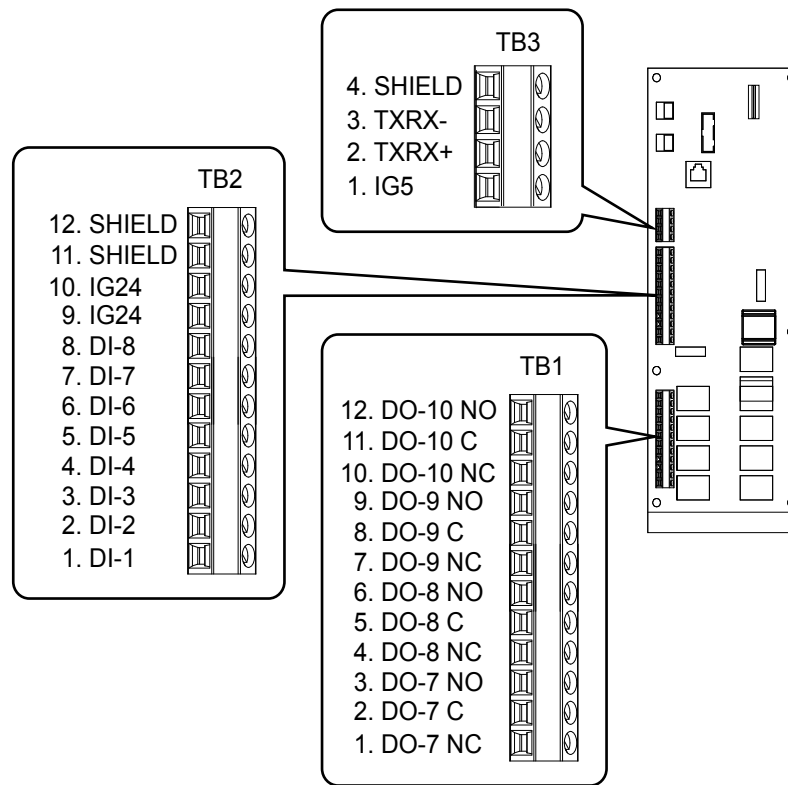

Figure 3.19 Control Circuit Terminal Board A2 Arrangement

Table 3.7 Z1000 Bypass Control Circuit Terminal Board A2

Type	Signal Name	Description	Specification
Digital Inputs	DI-1	Digital Input 1	Dry contact rated, photocoupler sinking input to IG, 24 Vdc 8 mA, ground fault protected
	DI-2	Digital Input 2	
	DI-3	Digital Input 3	
	DI-4	Digital Input 4	
	DI-5	Digital Input 5	
	DI-6	Digital Input 6	
	DI-7	Digital Input 7	
	DI-8	Digital Input 8	
	IG24	Isolated Ground	Digital Input Common

Type	Signal Name	Description	Specification
Digital Outputs 120 Vac	DO-1	Digital Output 1	(Factory use only) 120 Vac, 66 VA sealed, 1650 inrush
	DO-2	Digital Output 2	
	DO-3	Digital Output 3	
	DO-4	Digital Output 4	
	DO-5	Digital Output 5	
Digital Outputs	DO-6	Digital Output 6	Relay, dry contact form C, 30 Vdc or 120 Vac, DO-6 (factory use only), 3.7 Amp 360 VA, DO-7 to DO-10 for customer use, 2 Amp
	DO-7	Digital Output 7	
	DO-8	Digital Output 8	
	DO-9	Digital Output 9	
	DO-10	Digital Output 10	

Table 3.8 lists the available control circuit input terminals on the drive. Text in parenthesis indicates the default setting for each multi-function input.

The drive control circuit terminals on Terminal Board A1 are arranged as shown in Figure 3.20.

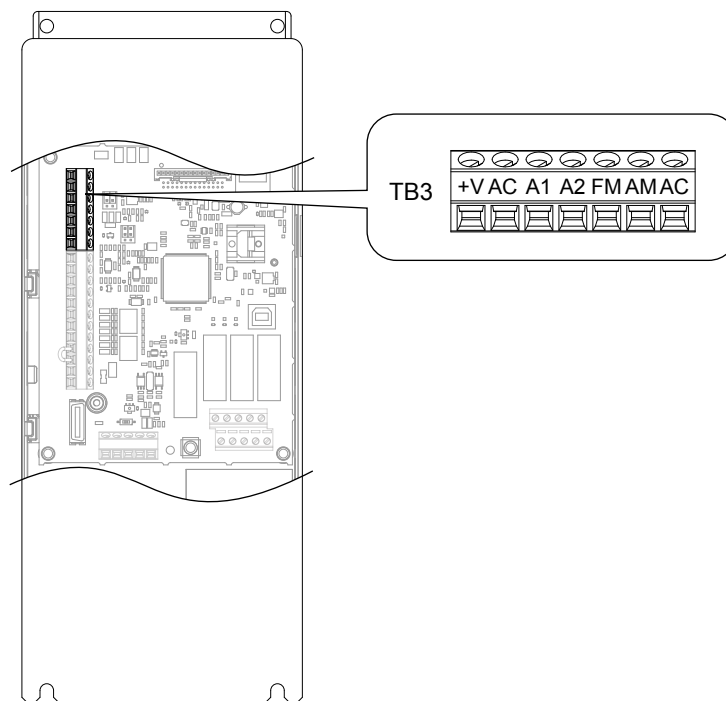

Figure 3.20 Control Circuit Terminal Board A1 Arrangement

Table 3.8 Drive Control Circuit Terminal Board A1

Type	No.	Terminal Name (Function)	Function (Signal Level) Default Setting	Page
Frequency Reference Inputs	+V	Power supply for analog inputs	10.5 Vdc (maximum allowable current 20 mA)	197
	A1	Multi-function analog input 1 (Frequency reference bias)	<ul style="list-style-type: none"> <li>0 to 10 Vdc/100% (input impedance: 20 kΩ)</li> <li>4 to 20 mA/100%, 0 to 20 mA/100% (input impedance: 250 Ω)</li> <li>Voltage or current input must be selected by Jumper S1 and H3-01.</li> </ul>	197 160
	A2	Multi-function analog input 2 (Frequency reference bias)	<ul style="list-style-type: none"> <li>0 to 10 Vdc/100% (input impedance: 20 kΩ)</li> <li>4 to 20 mA/100%, 0 to 20 mA/100% (input impedance: 250 Ω)</li> <li>Voltage or current input must be selected by Jumper S1 and H3-09.</li> </ul>	197 197 162
	AC	Frequency reference common	0 V	197
	FE	Ground for shielded lines and option cards	–	–
External Power Supply	+P	External Power Supply	24 V (Max. 150 mA)	–

### 3.5 Control Circuit Wiring

#### ◆ Bypass Analog Outputs

There are two analog outputs that can be configured for a signal level of 0 to 10 Vdc or 4 to 20 mA. The signal level is controlled by the position of jumpers J2 and J3 on Control PCB A2 and by the values set to drive parameters H4-07 and H4-08.

#### ◆ Serial Communications

Refer to *BACnet Communications on page 375* or *Refer to MEMOBUS/Modbus Communications on page 395* for details depending on the applicable serial communications protocol.

#### ■ Serial Communication Terminals

Table 3.9 Control Circuit Terminals: Serial Communications

Type	Name	Description	Notes
MEMOBUS/Modbus or BACnet Communication	IG5	Isolated ground	Ground reference for RS-485 signals. This is an isolated ground used only for communications and may be used in certain circumstances to connect to other communication devices floating ground references.
	TXRX+	(+) Differential communication signal	RS-485 signal levels
	TXRX-	(-) Differential communication signal	
	SHIELD	Shield tie point	Connected to chassis ground

#### ■ Bypass and Drive Control Circuit Wire Size and Torque Specifications

Select appropriate wire type and gauges from *Table 3.10*. For simpler and more reliable wiring, use crimp ferrules on the wire ends. Refer to *Table 3.11* for ferrule terminal types and sizes.

Table 3.10 Bypass and Drive Control Circuit Gauge and Torque Values

Terminal	Screw Size	Tightening Torque N•m (lb. in)	Bare Wire Terminal		Ferrule-Type Terminal		Wire Type
			Applicable wire size mm <sup>2</sup> (AWG)	Recomm. wire size mm <sup>2</sup> (AWG)	Applicable wire size mm <sup>2</sup> (AWG)	Recomm. wire size mm <sup>2</sup> (AWG)	
DO-7, DO-8, DO-9, DO-10 DI-1, DI-2, DI-3, DI-4, DI-5, DI-6, DI-7, DI-8, IG24 IG5, TXRX+, TXRX-, SHIELD	M3	0.5 to 0.6 (4.4 to 5.3)	Stranded wire: 0.2 to 1.0 (24 to 16) Solid wire: 0.2 to 1.5 (24 to 16)	0.75 (18)	0.25 to 0.5 (24 to 20)	0.5 (20)	Shielded wire, etc.
+V, A1, A2, AC FM, AM, AC R+, R-, S+, S-, IG	M3	0.5 to 0.6 (4.4 to 5.3)	Stranded wire: 0.2 to 1.0 (24 to 16) Solid wire: 0.2 to 1.5 (24 to 16)	0.75 (18)	0.25 to 0.5 (24 to 20)	0.5 (20)	Shielded wire, etc.

#### ■ Ferrule-Type Wire Terminals

Yaskawa recommends using CRIMPFOX 6, a crimping tool manufactured by PHOENIX CONTACT, to prepare wire ends with insulated sleeves before connecting to the drive. See *Table 3.11* for dimensions.

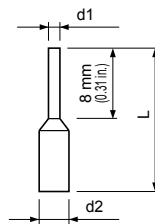

Figure 3.21 Ferrule Dimensions



Table 3.11 Ferrule Terminal Types and Sizes

Size mm <sup>2</sup> (AWG)	Type	L mm (in)	d1 mm (in)	d2 mm (in)	Manufacturer
0.25 (24)	AI 0.25-8YE	12.5 (0.49)	0.8 (0.03)	2.0 (0.08)	PHOENIX CONTACT
0.34 (22)	AI 0.34-8TQ	12.5 (0.49)	0.8 (0.03)	2.0 (0.08)	
0.5 (20)	AI 0.5-8WH AI 0.5-8OG	14.0 (0.55)	1.1 (0.04)	2.5 (0.10)	

## ◆ Drive Cover Removal

Follow the procedures below to remove and reattach the drive covers for wiring.

### ■ Drives Mounted on Z1000 Bypass Models Z1B1D143 to D273 and B124 to B302

#### Removing the Terminal Cover

1. Loosen the screws on the terminal cover, then pull down on the cover.

**CAUTION!** Do not completely remove the cover screws, just loosen them. If the cover screws are removed completely, the terminal cover may fall off causing an injury.

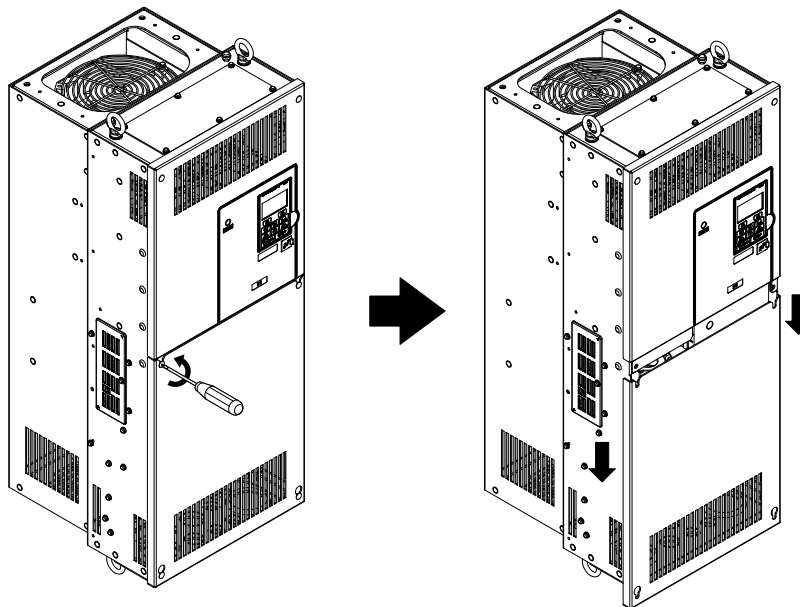
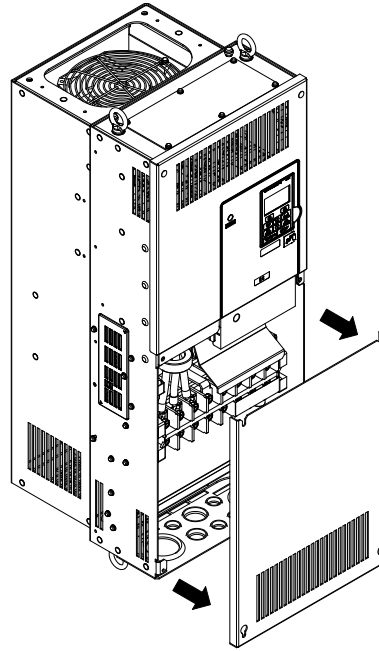

Figure 3.22 Removing the Terminal Cover

2. Pull forward on the terminal cover to free it from the drive.



**Figure 3.23 Removing the Terminal Cover**

#### Reattaching the Terminal Cover

After wiring, double-check connections and reattach the terminal cover.

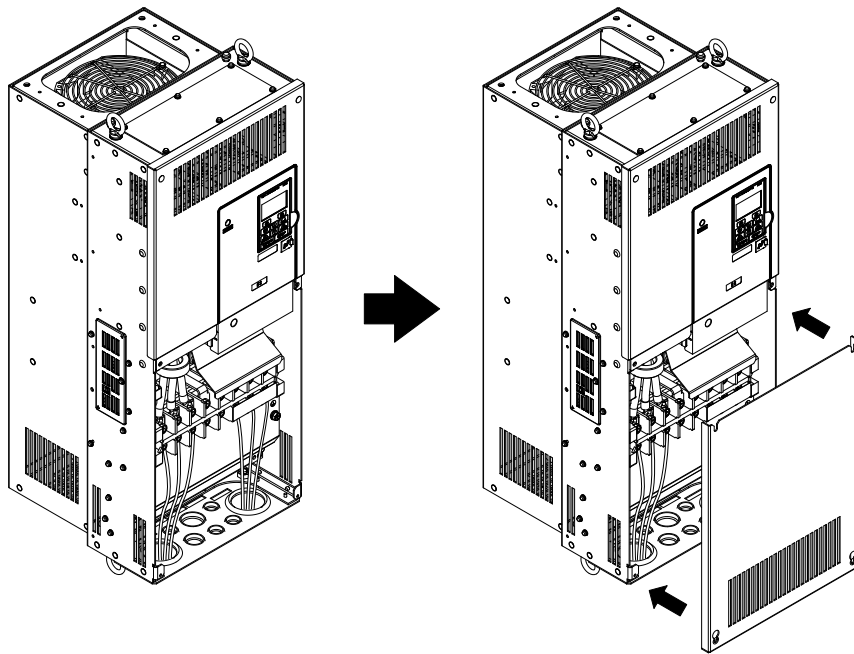

**Figure 3.24 Reattaching the Terminal Cover**

## ■ Removing the Front Cover

Drives Mounted on Z1000 Bypass Models Z1B1D002 to D059 and B001 to B52L

1. Loosen the front cover screw using a #2 Phillips screwdriver. Screw sizes vary by drive model.

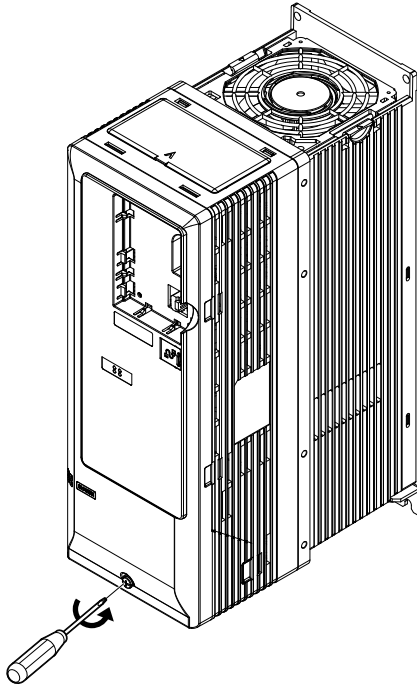

Figure 3.25 Remove the Front Cover (Models Z1B1D002 to D059 and B001 to B52L)

2. Push in on the tab located on the bottom of the front cover and gently pull forward to remove the front cover.

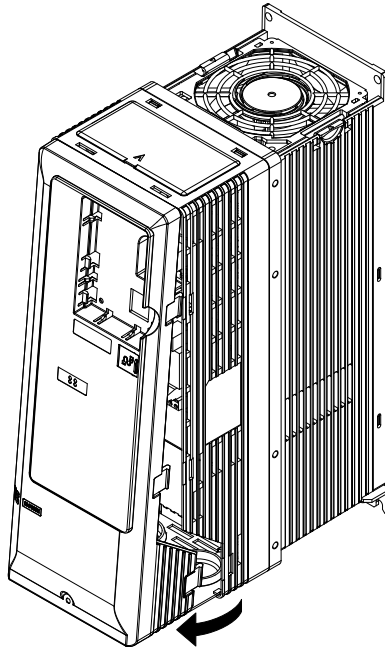
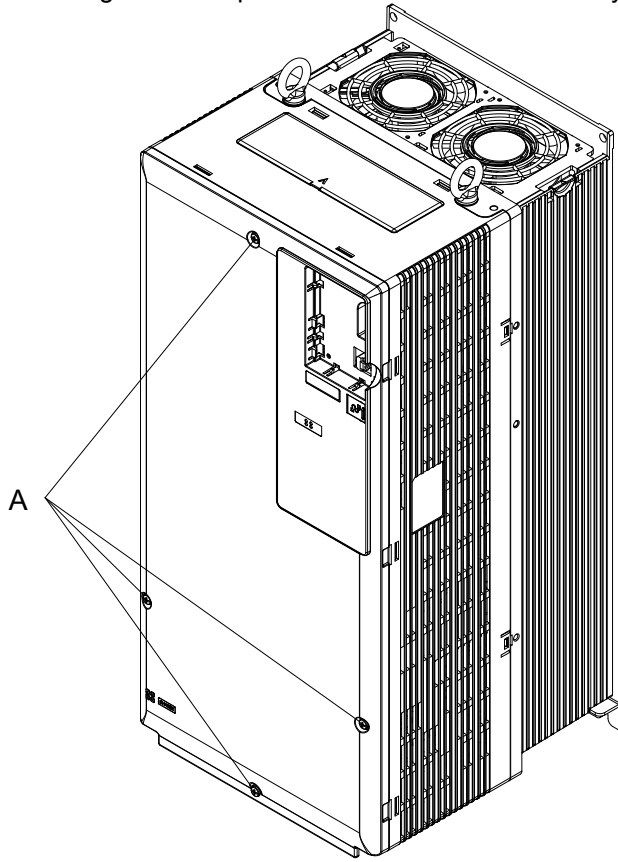

Figure 3.26 Remove the Front Cover (Models Z1B1D002 to D059 and B001 to B52L)

## 3.5 Control Circuit Wiring

### Drives Mounted on Z1000 Bypass Models Z1B1D074 to D114 and B052 to B096

1. Loosen the front cover screws using a #2 Phillips screwdriver. Screw sizes vary by drive model.



**A –Front cover screw locations**

**Figure 3.27 Remove the Front Cover (Models Z1B1D074 to D114 and B052 to B096)**

2. Pinch the tabs located on the bottom of the front cover and gently pull forward to remove the front cover.

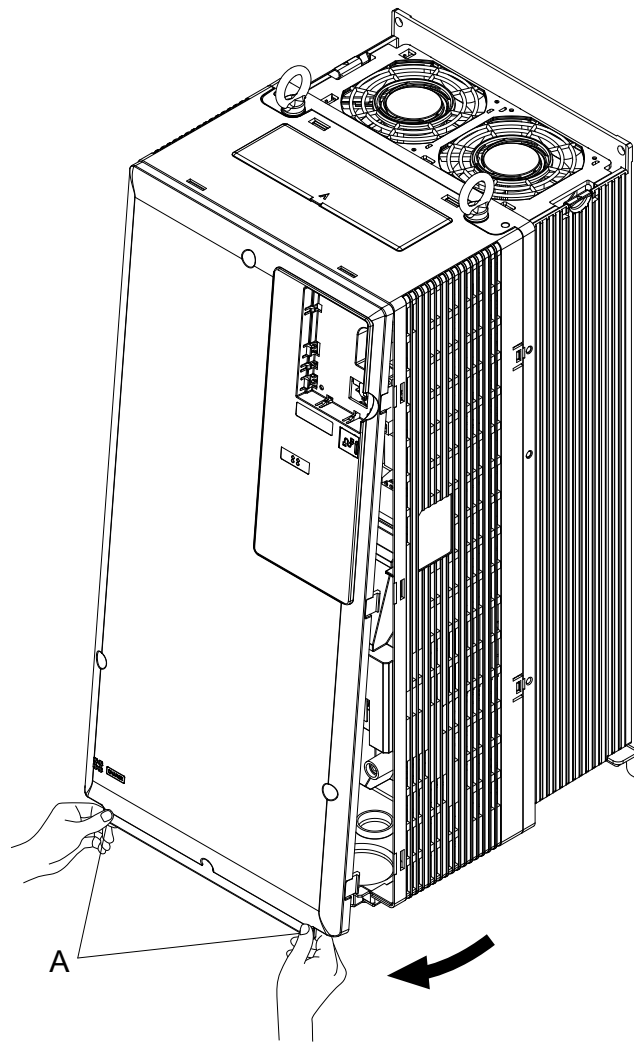

A –Location of tabs on front cover

Figure 3.28 Remove the Front Cover (Models Z1B1D074 to D114 and B052 to B096)

### 3.5 Control Circuit Wiring

#### Drives Mounted on Z1000 Bypass Models Z1B1D143 to D273 and B124 to B302

1. Remove the terminal cover.
2. Loosen the installation screw on the front cover.

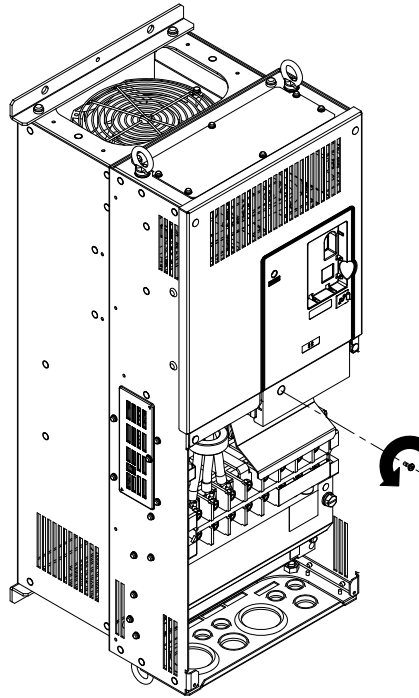

Figure 3.29 Loosen the Installation Screw (Models Z1B1D143 to D273 and B124 to B302)

3. Push the hooks on each side of the cover that hold it in place.

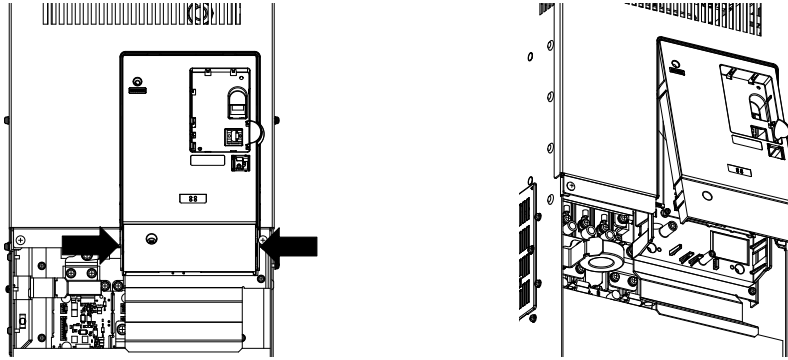

Figure 3.30 Remove the Front Cover (Models Z1B1D143 to D273 and B124 to B302)

## ■ Reattaching the Front Cover

### Drives Mounted on Z1000 Bypass Models Z1B1D002 to D114 and B001 to B096

Reverse the instructions given in *Removing the Front Cover (Drives Mounted on Z1000 Bypass Models Z1B1D002 to D059 and B001 to B52L)* on page 75 and *Removing the Front Cover (Drives Mounted on Z1000 Bypass Models Z1B1D074 to D114 and B052 to B096)* on page 76 to reattach the front cover. Pinch inwards on the hooks found on each side of the front cover while guiding it back into the drive. Make sure it clicks firmly into place.

Power lines and signal wiring should pass through the opening provided.

Reattach the front cover after completing the wiring to the drive and other devices.

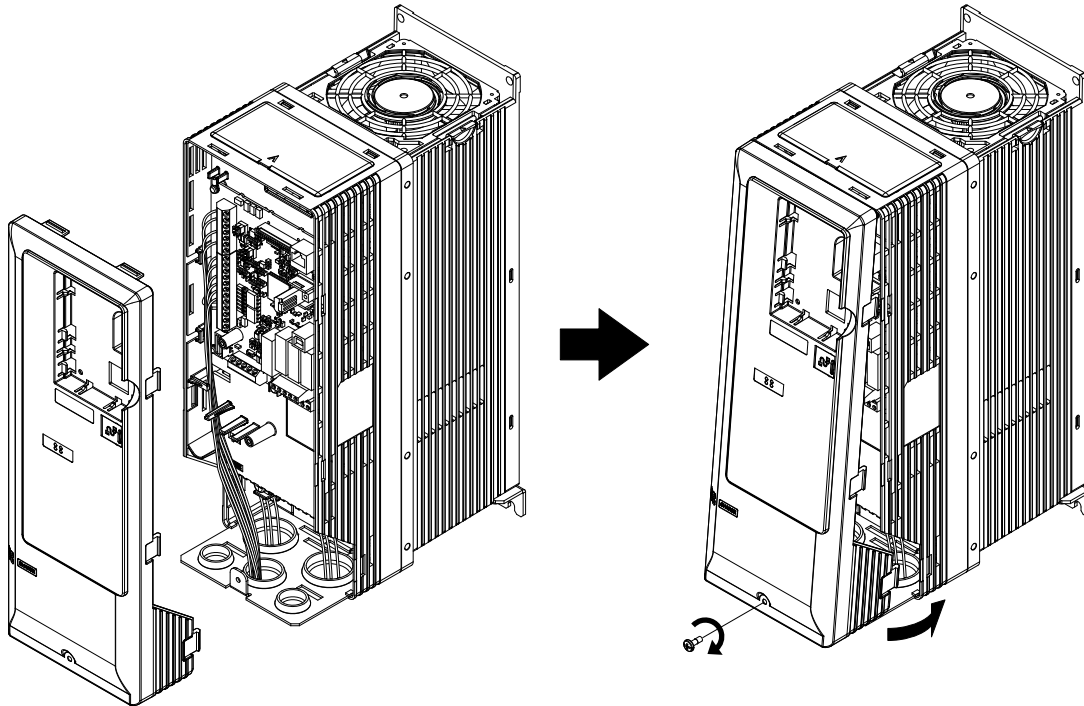

Figure 3.31 Reattach the Front Cover (Models Z1B1D002 to D114 and B001 to B096)

### Drives Mounted on Z1000 Bypass Models Z1B1D143 to D273 and B124 to B302

1. Slide the front cover so the hooks on the top connect to the drive.

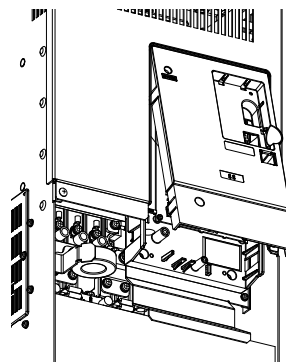

Figure 3.32 Reattach the Front Cover (Models Z1B1D143 to D273 and B124 to B302)

2. After connecting the hooks to the drive, press firmly on the cover to lock it into place.

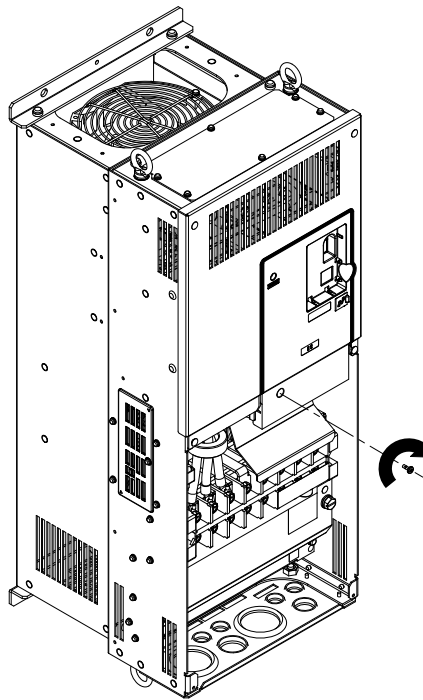

Figure 3.33 Tighten the Installation Screw to Lock the Cover into Place (Models Z1B1D143 to D273 and B124 to B302)

### ■ Top Protective Cover

Drives mounted on top of Z1000 Bypass enclosures are designed to NEMA Type 1 specifications with a protective cover on the top. Removing this top protective cover voids the NEMA Type 1 protection. Do not remove the top protective cover.

### ◆ Wiring the Drive Control Circuit Terminal

This section describes the proper procedures and preparations for wiring the control terminals.

**WARNING!** *Electrical Shock Hazard. Do not remove covers or touch the circuit boards while the power is on. Failure to comply could result in death or serious injury.*

**NOTICE:** *Separate control circuit wiring from main circuit wiring (terminals R/L1, S/L2, T/L3, -M, +M, -, +1, +3, U/T1, V/T2, W/T3) and other high-power lines. Improper wiring practices could result in drive malfunction due to electrical interference.*

**NOTICE:** *Separate wiring for digital output terminals MA, MB, MC, and M1 to M6 from wiring to other control circuit lines. Improper wiring practices could result in drive or equipment malfunction or nuisance trips.*

**NOTICE:** *Use a class 2 power supply when connecting to the control terminals. Improper application of peripheral devices could result in drive performance degradation due to improper power supply. Refer to NEC Article 725 Class 1, Class 2, and Class 3 Remote-Control, Signaling, and Power Limited Circuits for requirements concerning class 2 power supplies.*

**NOTICE:** *Insulate shields with tape or shrink tubing to prevent contact with other signal lines and equipment. Improper wiring practices could result in drive or equipment malfunction due to short circuit.*

**NOTICE:** *Connect the shield of shielded cable to the appropriate ground terminal. Improper equipment grounding could result in drive or equipment malfunction or nuisance trips.*

Wire the control circuit only after terminals have been properly grounded and main circuit wiring is complete. [Refer to Terminal Wiring Guide on page 81](#) for details. Prepare the ends of the control circuit wiring as shown in [Figure 3.40](#).

**NOTICE:** *Do not tighten screws beyond the specified tightening torque. Failure to comply may result in erroneous operation, damage to the terminal block, or cause a fire.*

**NOTICE:** *Use shielded twisted-pair cables as indicated to prevent operating faults. Improper wiring practices could result in drive or equipment malfunction due to electrical interference.*

Connect control wires as shown in [Figure 3.34](#) and [Figure 3.35](#).

Yaskawa recommends Phoenix Contact screwdriver model SZF 0-0.4 x 2.5 or equivalent to wire the terminal block.



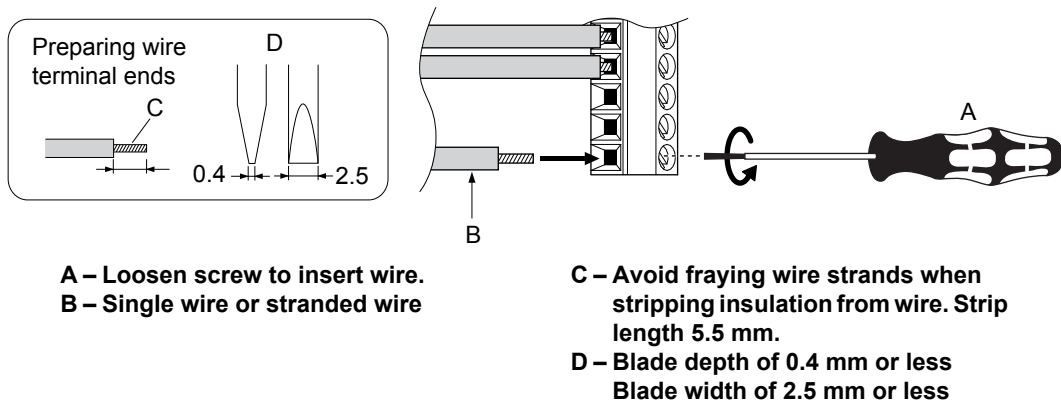

Figure 3.34 Terminal Wiring Guide

Use the cable tie holes and cable hooks when wiring control terminals.

**Note:** Take proper precautions when wiring the cables so that the front covers will easily fit back onto the drive. Make sure cables are not pinched between the front covers and the drive when replacing the covers.

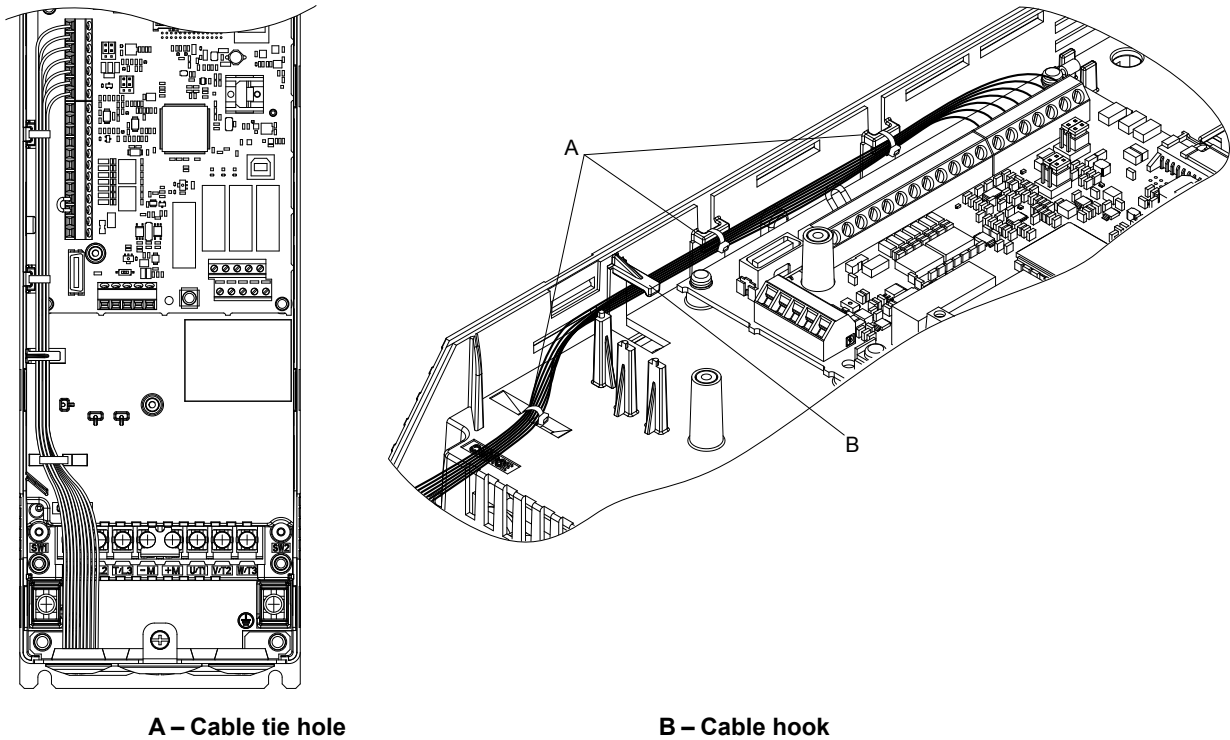
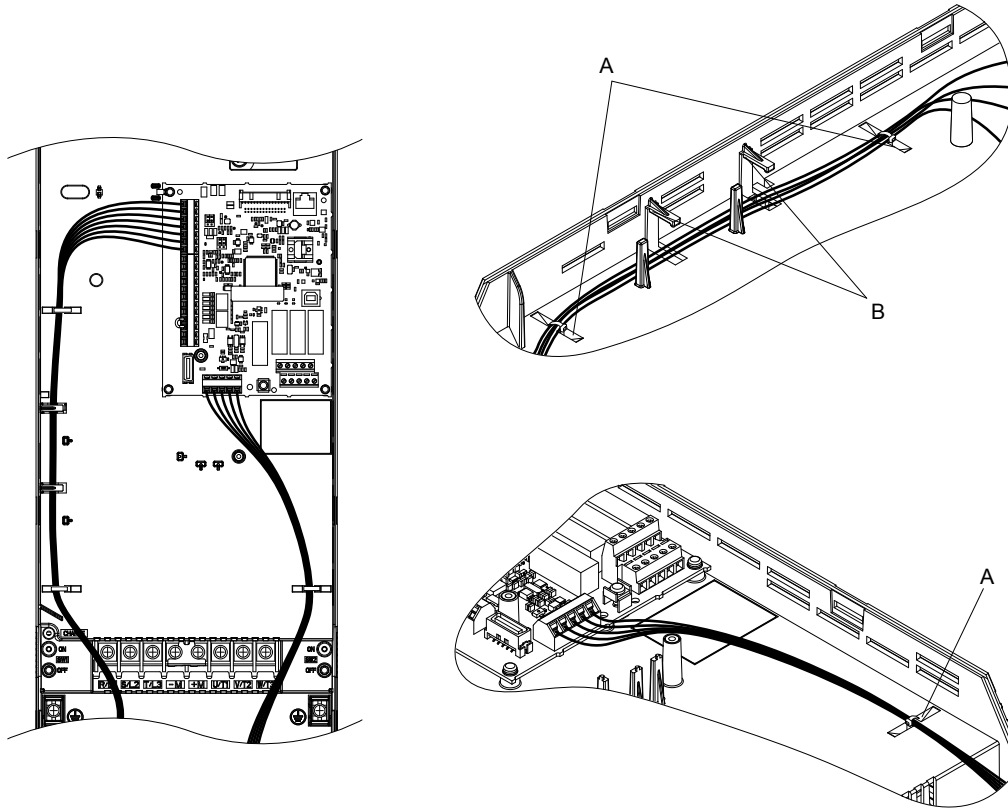

Figure 3.35 Control Terminal Wiring (Models Z1B1D002 to D030 and B001 to B027)



A – Cable tie hole

B – Cable hook

Figure 3.36 Control Terminal Wiring (Models Z1B1D046 to D059 and B034 to B52L)

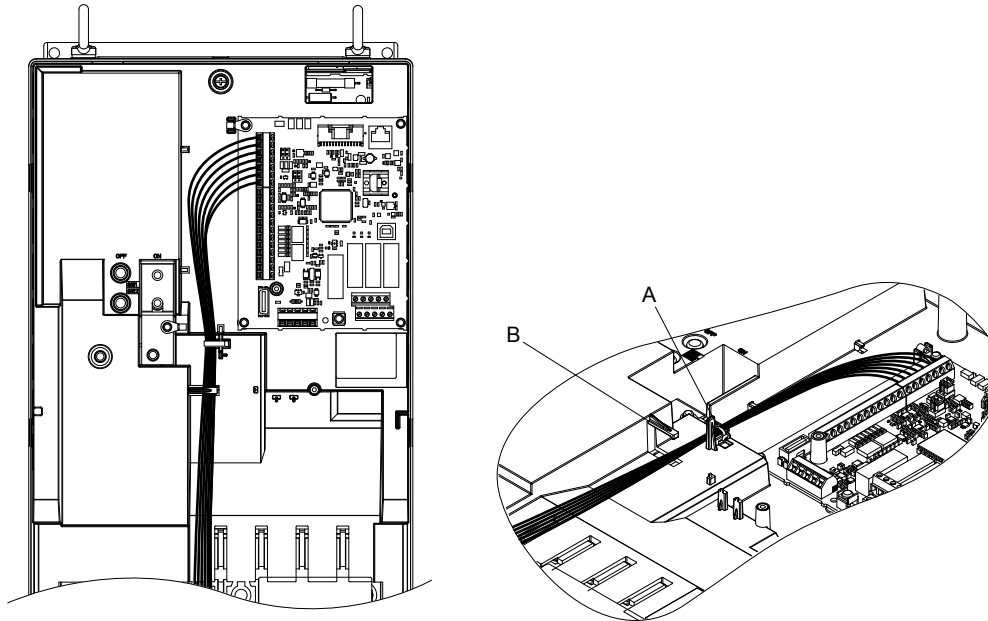

A – Cable tie hole

B – Cable hook

Figure 3.37 Control Terminal Wiring (Models Z1B1D074 to D114 and B052 to B096)

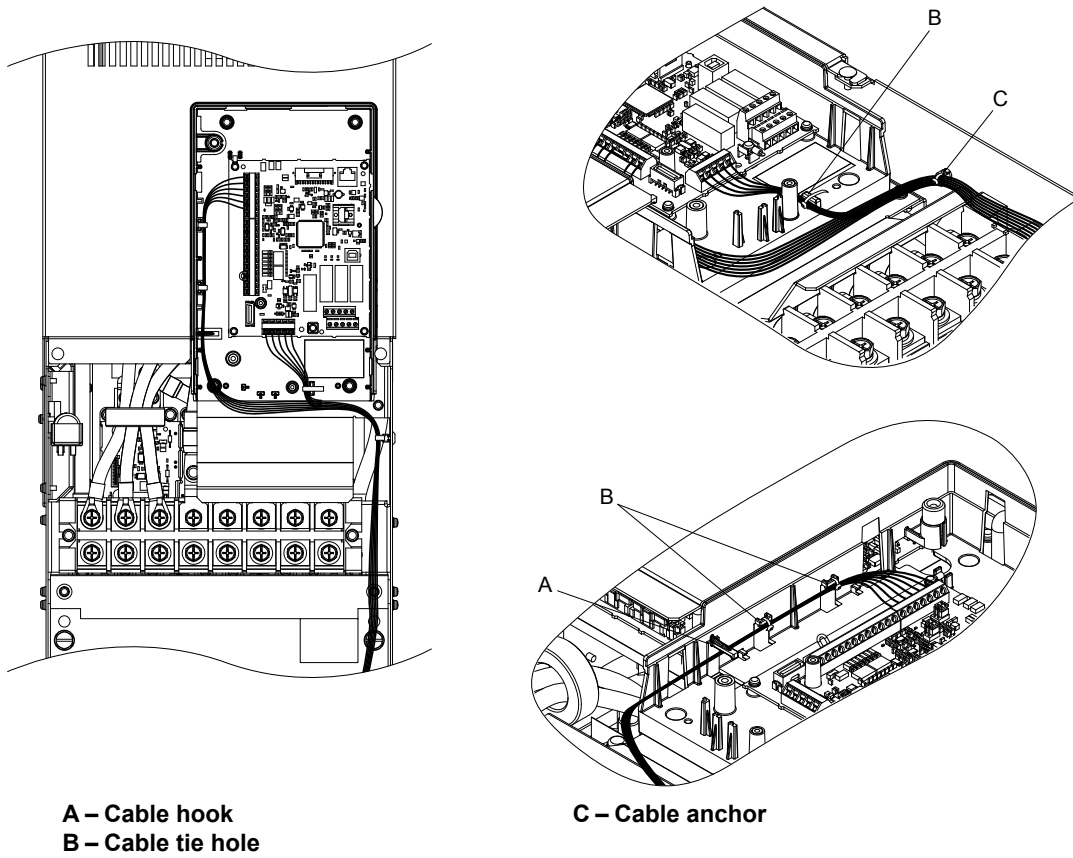

Figure 3.38 Control Terminal Wiring (Model Z1B1B124)

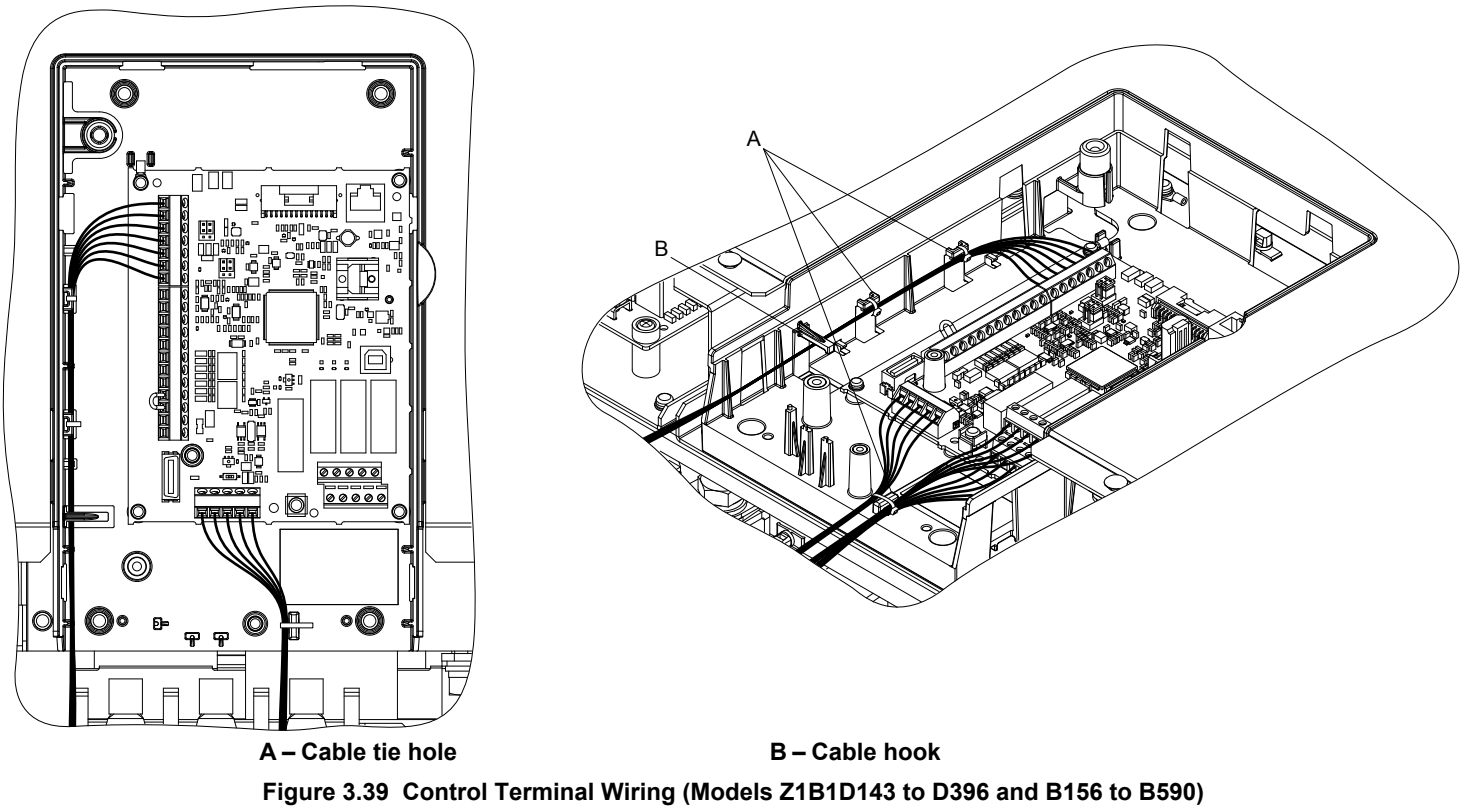
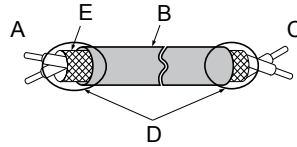

Figure 3.39 Control Terminal Wiring (Models Z1B1D143 to D396 and B156 to B590)

### 3.5 Control Circuit Wiring

When setting the frequency by analog reference from an external potentiometer, use shielded twisted-pair wires, preparing wire ends as shown in *Figure 3.40*. Connect the shield to the ground terminal of the drive.



- A – Drive side
- B – Insulation
- C – Control device side
- D – Shield sheath (insulate with tape)
- E – Shield

**Figure 3.40** Preparing the Ends of Shielded Cables

**NOTICE:** The analog signal wiring between the drive and the operator station or peripheral equipment should not exceed 50 meters when using an analog signal from a remote source to supply the frequency reference. Failure to comply could result in poor system performance.

### ◆ Switches and Jumpers on the Control Board

The control board is equipped with several switches used to adapt the drive I/Os to the external control signals. *Figure 3.41* shows the location of these switches. Refer to *Bypass and Drive Control I/O Connections on page 85* for setting instructions.

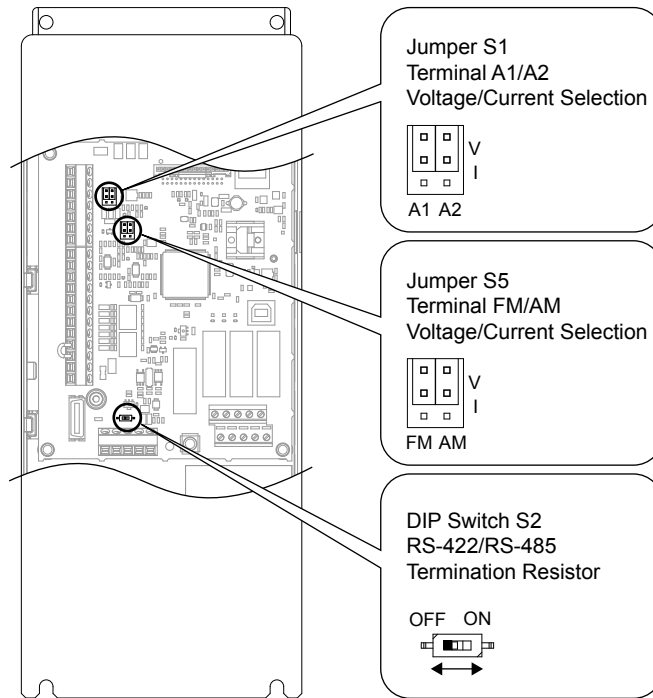

**Figure 3.41** Locations of Jumpers and Switches on the Control Board

## 3.6 Bypass and Drive Control I/O Connections

### ◆ Input Signal Selection for Terminals A1 and A2

Terminals A1 and A2 can be used to input either a voltage or a current signal. Select the signal type using jumper S1 as explained in [Table 3.12](#). Set parameters H3-01 and H3-09 accordingly as shown in [Table 3.13](#). *Refer to Switches and Jumpers on the Control Board on page 84* for locating switch S1.

**Note:** If terminals A1 and A2 are both set for frequency bias (H3-02 = 0 and H3-10 = 0), both input values will be combined to create the frequency reference.

Table 3.12 Jumper S1 Settings





Terminal	Voltage Output	Current Output
Terminal A1		
Terminal A2		

Table 3.13 Parameters H3-01 and H3-09 Details

No.	Parameter Name	Description	Setting Range	Default Setting
H3-01	Terminal A1 signal level selection	Selects the signal level for terminal A1. 0: 0 to 10 V with Zero Limit 1: 0 to 10 V without Zero Limit 2: 4 to 20 mA Current Input 3: 0 to 20 mA Current Input	0 to 3	0
H3-09	Terminal A2 signal level selection	Selects the signal level for terminal A2. 0: 0 to 10 V with Zero Limit 1: 0 to 10 V without Zero Limit 2: 4 to 20 mA Current Input 3: 0 to 20 mA Current Input	0 to 3	0

### ◆ Terminal FM/AM Signal Selection

The signal type for terminals FM and AM can be set to either voltage or current output using jumper S5 on the terminal board as explained in [Table 3.14](#). When changing the setting of jumper S5, parameters H4-07 and H4-08 must be set accordingly. The default selection is voltage output for both terminals. *Refer to Switches and Jumpers on the Control Board on page 84* for locating jumper S5.

Table 3.14 Jumper S5 Settings





Terminal	Voltage Output	Current Output
Terminal FM		
Terminal AM		

Table 3.15 Parameter H4-07 and H4-08 Details

No.	Parameter Name	Description	Setting Range	Default Setting
H4-07	Terminal FM signal level selection	0: 0 to 10 Vdc 2: 4 to 20 mA	0, 2	0
H4-08	Terminal AM signal level selection			

## 3.7 External Interlock

Systems that may be affected during drive fault conditions should be interlocked with the drive fault output and ready signal.

### ◆ Annunciation Contact Outputs

Annunciation contacts for customer use are provided at terminal blocks TB1 as indicated in [Table 3.16](#). Annunciation contacts are used to indicate the status of bypass operation. Contacts are rated for 2 Amps, 24 Vdc/120 Vac +/- 15% maximum.

**Table 3.16 Annunciation Contact Details**

Function <1>	Name	Terminal Block	Terminals	Type
Motor Run	DO-7	TB1	1-2-3	Form C
Hand Mode	DO-8	TB1	4-5-6	Form C
Auto Mode	DO-9	TB1	7-8-9	Form C
System Fault	DO-10	TB1	10-11-12	Form C

<1> Default settings are shown. Set parameters Z2-23 to Z2-26 to choose other functions.

The function of output relays DO-7 through DO-10 may be reprogrammed via bypass parameters Z2-23 through Z2-26. These form C dry contact relays are for customer use in annunciation to building automation systems (BAS) or other circuits. Each contact is rated for 2 amps at 120 Vac.

[Refer to Z2-01 to Z2-08: Digital Input 1 to 8 Function Select on page 210](#) for descriptions of the programmable functions of annunciation contacts.

### ◆ Building Automation System Run/Stop Circuit

DI-1 (TB2-1 by default setting in Z2-01) is available to connect the normally open (N.O.) Run/Stop contact from a BAS or other remote controller for auto mode control.

These terminals must have contact closure for the motor to run in AUTO mode.

### ◆ Safety Interlock Circuit

DI-2 (TB2-2 by default setting in Z2-02) is provided to connect safety devices in a normally-closed series circuit, such as: freeze up thermostats, smoke/fire sensors, high pressure limits, temperature limits or vibration detectors.

The HOA keypad will display the status “Safety Open”, and trigger a Safety Open fault if a N.C. safety circuit is not closed between DI-2 and IG24 (TB2-10) on PCB A2 at power-up with a Run command in HAND or AUTO mode. An open circuit between DI-2 and IG24 will prevent bypass operation.

Take one of the following steps to ensure proper operation prior to startup:

1. Install a N.C. safety circuit between DI-2 and IG24 on PCB A2.
2. Install a jumper between DI-2 and IG24 (on PCB A2). A normally-closed safety circuit may also be used in place of this jumper.

### ◆ Building Automation System Interlock Circuit (Drive and Bypass Enable Input)

The HOA keypad will display the status “INTRLOCK OPN” and possibly a “BAS Ilock-open” alarm or “BAS Ilock TO” fault if a N.C. safety circuit is not closed between DI-3 (TB2-3 by default setting of Z2-03) and IG24 on PCB A2 at power-up with a Run command in HAND or AUTO mode. An open circuit between TB2-3 and IG24 (TB2-10) will prevent bypass operation.

Take one of the following steps to ensure proper operation prior to startup:

1. Install a N.C. BAS Interlock Circuit/Damper Interlock between DI-3 and IG24 on PCB A2.
2. Install a jumper between DI-3 and IG24 on PCB A2. A normally-closed BAS interlock may also be used in place of this jumper.

---

### ◆ Remote Transfer to Bypass

Terminal TB2-4 is a programmable input with a default setting of “Remote Transfer to Bypass” operation. The function of this terminal can be changed using bypass parameter Z2-04.

This function allows a contact closure from a BAS, between terminals TB2-4 and TB2-10, to transfer motor operation from Drive mode to Bypass mode. An open contact allows operation in Drive mode and a closed contact allows operation in Bypass mode.

---

### ◆ Smoke Purge Operation

Terminal TB2-5 is a programmable input with a default setting of “Smoke Purge” operation. The function of this terminal can be changed using bypass parameter Z2-05.

This function allows a contact closure between terminals TB2-5 and TB2-10 to transfer motor operation to bypass for smoke purge operation. The motor overload and Safety Interlock circuit are overridden during smoke purge or in emergency fire/smoke situations to place priority on personnel protection.

**Note:** Smoke purge overrides all control inputs and bypass selector buttons. Smoke purge operation can only be terminated by opening the contact closure at terminal TB2-5 or by opening the disconnect switch.

---

### ◆ Spare Multi-Function Digital Inputs

Terminals TB2-6 and TB2-7 are spare programmable inputs. The Bypass +24 V logic circuit is interconnected with the drive multi-function digital inputs to allow a single customer interface to control both drive and bypass circuits. The function of these terminals can be set using bypass parameters Z2-06 and Z2-07.

**This Page Intentionally Blank**



# Start-Up Programming & Operation

---

This chapter explains HOA keypad functions and gives instructions on programming the Z1000 Bypass for initial operation.

<b>4.1</b>	<b>SECTION SAFETY.....</b>	<b>90</b>
<b>4.2</b>	<b>USING THE HOA KEYPAD.....</b>	<b>91</b>
<b>4.3</b>	<b>THE DRIVE AND PROGRAMMING MODES.....</b>	<b>99</b>
<b>4.4</b>	<b>POWERING UP THE DRIVE.....</b>	<b>103</b>
<b>4.5</b>	<b>START-UP PROCEDURE.....</b>	<b>104</b>
<b>4.6</b>	<b>APPLICATION SELECTION.....</b>	<b>108</b>
<b>4.7</b>	<b>AUTO-TUNING.....</b>	<b>111</b>

## 4.1 Section Safety

### WARNING

#### Electrical Shock Hazard

**Do not connect or disconnect wiring while the power is on.**

Failure to comply could result in death or serious injury.

Before servicing, disconnect all power to the equipment. The internal capacitor remains charged even after the power supply is turned off. The charge indicator LED will extinguish when the DC bus voltage is below 50 Vdc. To prevent electric shock, wait for at least the time specified on the warning label, once all indicators are OFF, measure for unsafe voltages to confirm the drive is safe prior to servicing.

**Do not operate equipment with covers removed.**

Failure to comply could result in death or serious injury.

The diagrams in this section may include drives without covers or safety shields to illustrate details. Be sure to reinstall covers or shields before operating the drives and run the drives according to the instructions described in this manual.

**Do not remove covers or touch circuit boards while the power is on.**

Failure to comply could result in death or serious injury.

## 4.2 Using the HOA Keypad

Use the HOA keypad to enter OFF commands, switch AUTO or HAND Mode, change parameters, and display data including fault and alarm information.

### ◆ HOA Keypad and Control Panel Display

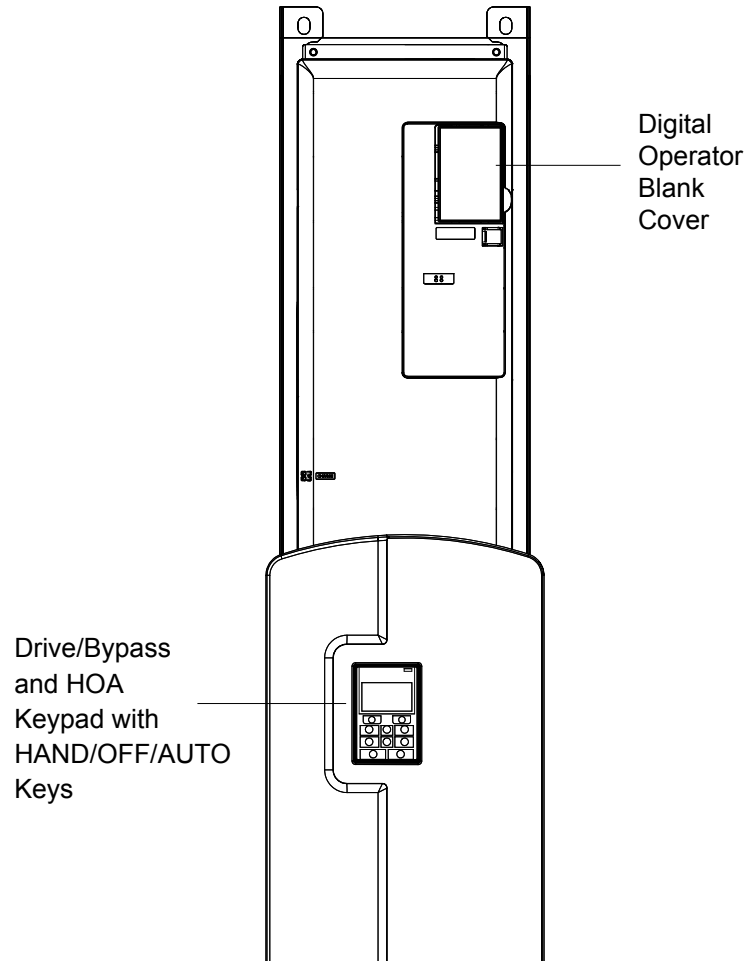

Figure 4.1 Z1000 Bypass HOA Keypad

### ◆ HOA Keypad Keys and Displays

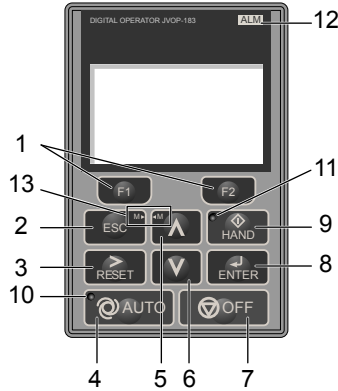

Figure 4.2 Description of HOA Keypad Keys and Displays

No.	Display	Name	Function
1		Function Key F1 (Drive Test)	Selects Drive Test Mode
		Function Key F2 (Bypass/Drive)	Toggles selection between Bypass Mode and Drive Mode.
2		ESC Key	<ul style="list-style-type: none"> <li>Returns to the previous display.</li> <li>Moves the cursor one space to the left.</li> <li>In Drive Mode, pressing and holding this button will return to the Frequency Reference display.</li> <li>In Bypass Mode, pressing and holding this button will return to the Bypass Main Menu.</li> <li>During parameter entry, allows aborting the current edited value and exits the parameter editing mode.</li> </ul>
3		RESET Key	<ul style="list-style-type: none"> <li>Moves the cursor to the right.</li> <li>Resets the bypass or drive to clear a fault situation.</li> </ul>
4		AUTO Key	Selects AUTO mode.
5		Up Arrow Key	Scrolls up to display the next item, selects parameter numbers, and increments setting values.
6		Down Arrow Key	Scrolls down to display the previous item, selects parameter numbers, and decrements setting values.
7		OFF Key	<p>Selects OFF mode.</p> <p>If the drive was operating the motor, the motor will stop according to the stopping method selected in b1-03.</p> <p>If the bypass was operating the motor, the bypass contactor opens and the motor coasts to a stop.</p>
8		ENTER Key	<ul style="list-style-type: none"> <li>Enters parameter values and settings.</li> <li>Selects a menu item to move between displays.</li> </ul>
9		HAND Key	Selects HAND mode.
10		AUTO Light	Lit while the drive is in AUTO mode. Refer to page 95 for details.
11		HAND Light	Lit while the drive is in HAND mode. Refer to page 95 for details.
12		ALM LED Light	<i>Refer to ALARM (ALM) LED Displays on page 95.</i>
13		ESC Key Up Arrow Key	In Drive Mode, during parameter entry, pressing both ESC Key and Up Arrow Key simultaneously will return to the monitor menu without changing the parameter value.

<1> Available for bypass control software versions VST800400 and later.

## ◆ LCD Display

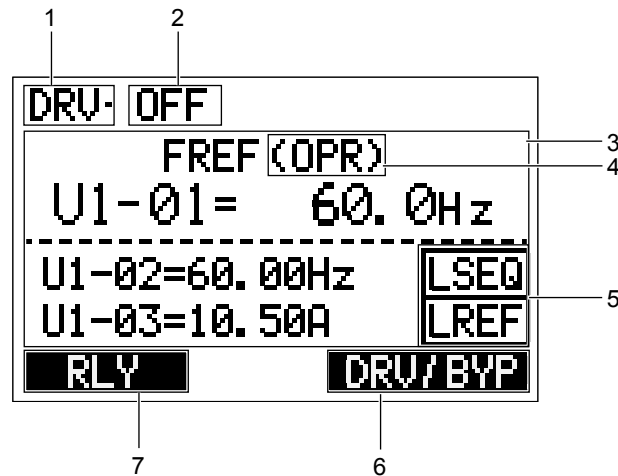











Figure 4.3 LCD Display

Table 4.1 Display and Contents

No.	Name	Display	Content
1	Bypass/Drive Status Display	DRV (not blinking)	Displayed when In Drive Mode. The bypass will run in Drive Mode when a Run command is present.
		DRV (blinking)	Displayed when in Drive Mode, but a condition is making the bypass run in Bypass Mode.
		BYP (not blinking)	Displayed when in Bypass Mode. The Bypass will run in Bypass Mode when a Run command is present. In a three-contactor bypass, drive input contactor K1 is open and the drive will be powered down.
		BYP (blinking)	Displayed when in Bypass Mode with Drive Test Mode set. The bypass will run in Bypass Mode when a Run command is present. In a three-contactor bypass, drive input contactor K1 is closed and the drive is powered on.

## 4.2 Using the HOA Keypad

No.	Name	Display	Content
2	Bypass Status Display	POWERUP	Displayed when the bypass is powering up.
		OFF	Displayed when no Run command is present and the safety circuit is closed.
		WAIT FOR RUN	Displayed when Run is requested, the safety circuit is closed, and the bypass is waiting for Run input.
		SAFETY OPEN	Displayed when the safety circuit input is open.
		INTRLOCK OPN	Displayed when a Run command is present, the safety circuit is closed, but the Interlock input is open.
		PRE RUN DRIVE	Displayed when the bypass is running in the Pre-Run State at the programmed frequency for the programmed time.
		RUN DRIVE	Displayed when running in Drive Mode.
		RUN BYPASS	Displayed when running in Bypass Mode.
		RMOT XFER EN	Displayed when running in Remote Transfer.
		SMOK PRG BYP	Displayed when running in Smoke Purge Bypass.
		SMOK PRG DRV	Displayed when running in Smoke Purge Drive.
		AUTO XFER EN	Displayed when running in Auto Transfer, a fault was detected and switched to Bypass Mode.
		ENRGY SAVEN	Displayed when running in Energy Savings Mode
		MTR STOPPING	Displayed when fault is removed but motor is still ramping down.
FAULTED	Displayed when a fault has been detected causing motor output contactors to open.		
3	Data Display	—	Displays specific data and operation data.
4	Frequency Reference Source <1>	OPR	Displayed when the frequency reference source is the HOA keypad.
		COM	Displayed when the frequency reference source is the MEMOBUS/Modbus Communication Inputs of the drive.
		OP	Displayed when the frequency reference source is an option card connected to the drive.
		AI	Displayed when the function reference is assigned to an analog input.
		OFF	Displayed when HAND mode is OFF.
5	LOCAL/REMOTE Display <2>	RSEQ	Displayed when the run command is supplied from a remote source.
		LSEQ	Displayed when the run command is supplied from the operator keypad.
		RREF	Displayed when the run command is supplied from a remote source.
		LREF	Displayed when the run command is supplied from the operator keypad.
6	Function Key 2 (F2)	DATA	Pressing  scrolls to the next display.
		→	Pressing  scrolls the cursor to the right.
		DRV/BYP	Pressing  toggles selection between Bypass Mode and Drive Mode.
7	Function Key 1 (F1)	HELP	Pressing  displays the Help menu.
		←	Pressing  scrolls the cursor to the left.
		HOME	Pressing  returns to the top menu (Frequency Reference).
		ESC	Pressing  returns to the previous display.
		Monitor	Pressing  switches Monitor mode.
		RLY	Pressing  selects/deselects Drive Test Mode. Enters and exits Drive Test Mode when in Bypass Mode (Open/Close K1). This is only possible with a 3-contactor bypass configuration (Option B).

<1> Displayed when in Frequency Reference Mode.

<2> Displayed when in Frequency Reference Mode and Monitor Mode.

## ◆ Bypass Control Board LEDs

The bypass control board A2 has six bi-color LEDs.



The operational states of the bypass LEDs after completion of the power-up diagnostic LED sequence are described in [Table 4.2](#). Wait at least 2 seconds for the power-up diagnostic process to complete before verifying LED states.

**Table 4.2 Bypass Control Board LED States**

Name	Description	Color	Behavior
MS	Module Status	Red	Not used
		Green	Turns ON when transmitting Turns OFF when receiving
NS	Network Status	Red	Not used
		Green	Turns ON when transmitting Turns OFF when receiving
ST1	ST1, Status 1	Red	Not used
		Green	Round status Toggles ON/OFF every 500 rounds
ST2	ST2, Status 2	Red	Not used
		Green	Scan status Toggles ON/OFF every 500 scans
ST3	ST3, Status 3	Red	Not used
		Green	Not used
ST4	ST4, Status 4	Red	Not used
		Green	Not used



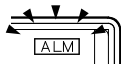







## ◆ ALARM (ALM) LED Displays

**Table 4.3 ALARM (ALM) LED Status and Contents**









State	Content	Display
Illuminated	When the drive detects an alarm or error.	
Flashing	<ul style="list-style-type: none"> <li>When an alarm occurs.</li> <li>When an oPE is detected.</li> <li>When a fault or error occurs during Auto-Tuning.</li> </ul>	
Off	Normal operation (no fault or alarm).	

## ◆ AUTO LED and HAND LED Indications

**Table 4.4 AUTO LED and HAND LED Indications**

AUTO LED	HAND LED	State
 Off	 Off	OFF mode
 Off	 On solid	HAND mode (Also during DC injection braking)
 Off	 Long blink (50% duty)	HAND mode when the Frequency Reference is 0 and/or decelerating in HAND mode, or during PI Sleep or Snooze.
 On solid	 Off	Running in AUTO mode (Also during DC injection braking)
 Off	 Short blink (15% duty)	HAND mode, Ready, No Run command input. <b>Note:</b> Short Blink for Legacy Operation Mode (S5-04 = 0).

## 4.2 Using the HOA Keypad

AUTO LED	HAND LED	State
 Off	 Double blink	HAND mode, cycle the Run command.
 Long blink (50% duty)	 Off	Running in AUTO mode when the Frequency Reference is 0 and/or decelerating in AUTO mode, or during PI Sleep or Snooze.
 Short blink (15% duty)	 Off	AUTO mode, Ready, No run command input.
 Double blink	 Off	AUTO mode, stopped by a Fast- Stop from a Multi-Function Digital Input.

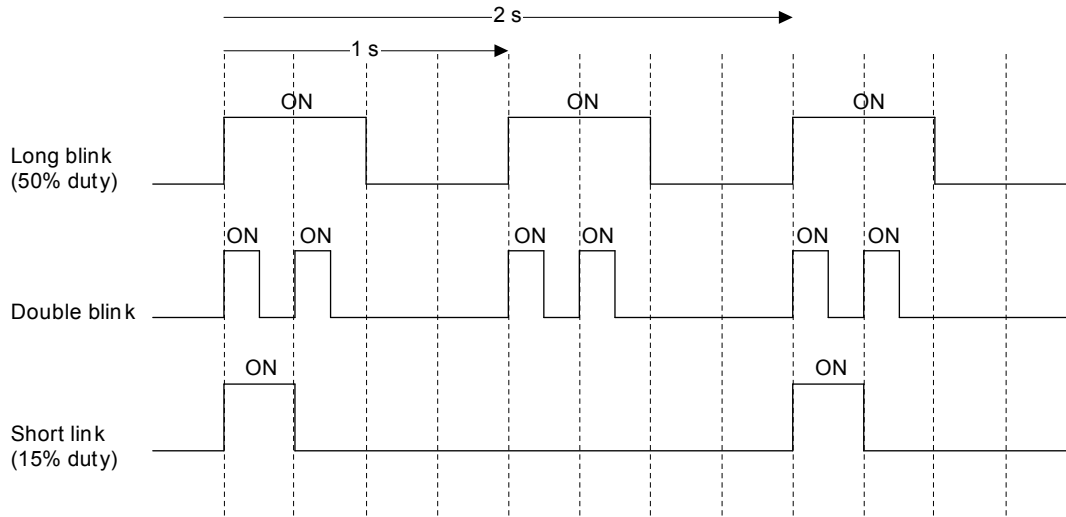

Figure 4.4 AUTO LED and HAND LED Timing Status

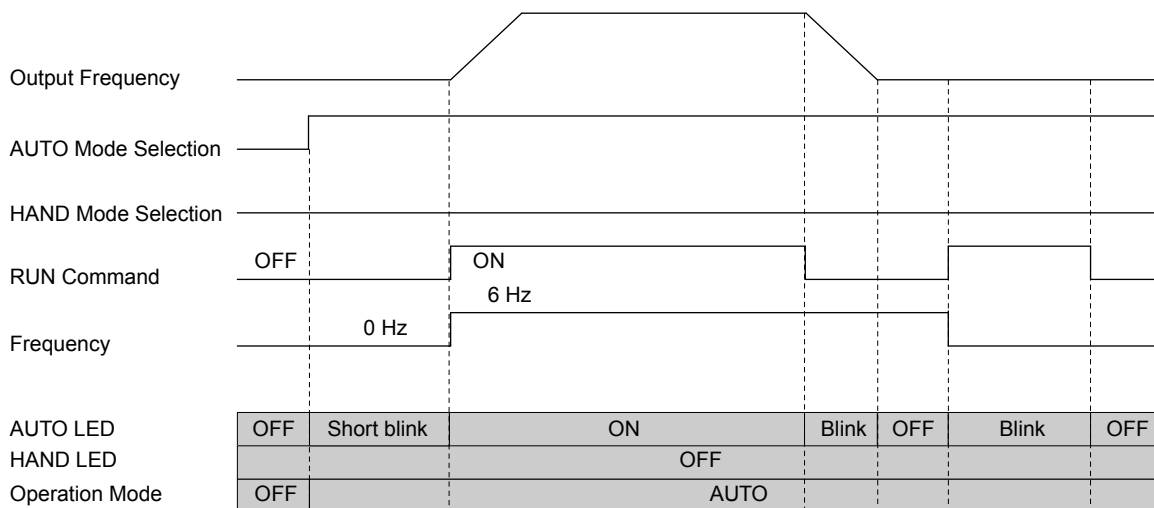

Figure 4.5 LEDs and Drive Operation in AUTO and HAND Modes



### ◆ HOA Keypad Menu Structure

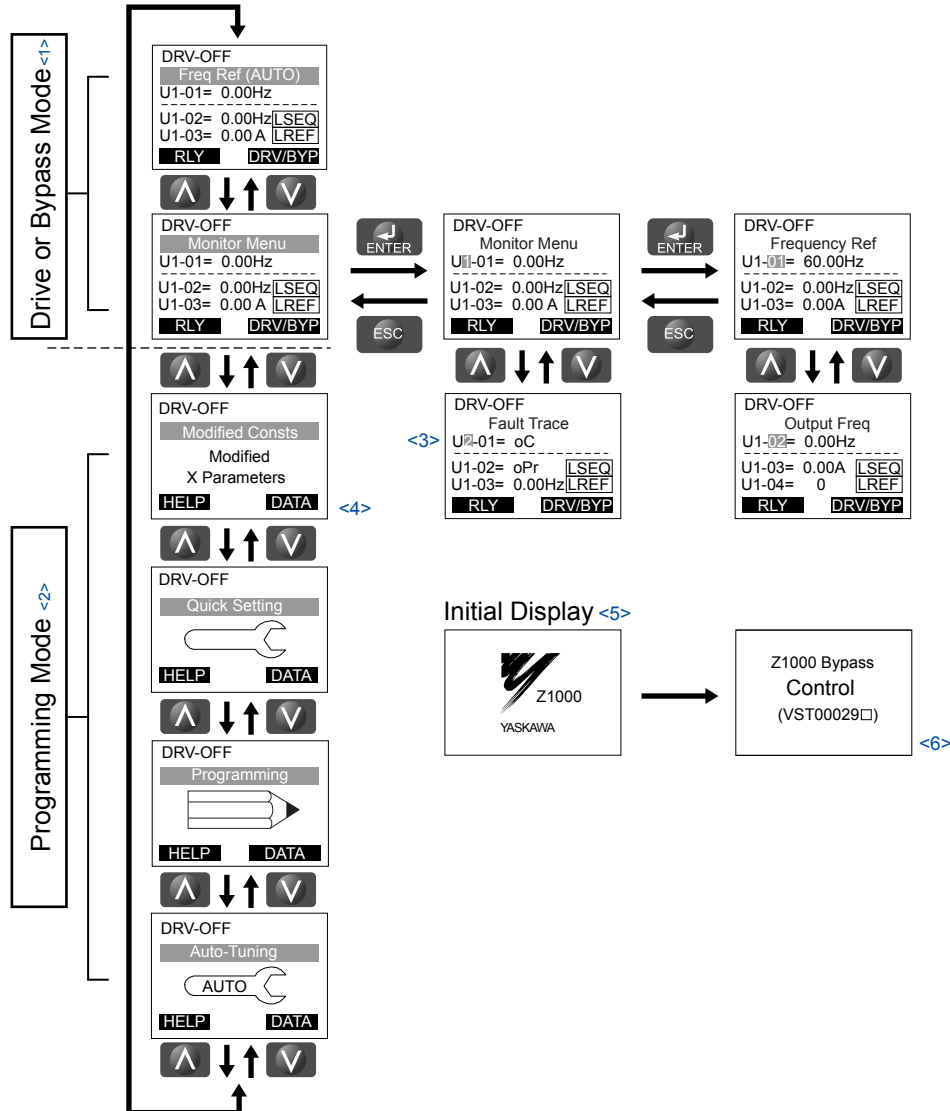

Figure 4.6 HOA Keypad Menu and Screen Structure

- <1> Pressing or will start the motor.
- <2> In Programming Mode, the AUTO and HAND keys are ignored.
- <3> Flashing characters are shown with white letters on gray background. (Example: )
- <4> “X” characters are used as examples in this manual. The HOA keypad will display the actual setting values.
- <5> The Frequency Reference appears after the initial display that shows the product name.
- <6> The information that appears on the display will vary depending on the drive.

### ◆ HOA Keypad Parameter Display (Drive Off)

When in bypass mode, (3-contactor bypass), or if there is no power to the drive, the way the drive-specific parameters are displayed changes.

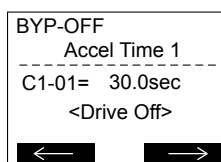
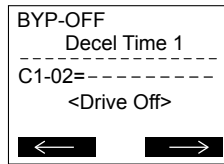

Figure 4.7 Drive-Specific Parameter

## 4.2 Using the HOA Keypad

**Figure 4.7** shows the LCD display with a typical drive-specific parameter displayed and no power to the drive. In this example, the parameter displayed is stored both in the drive and in the bypass controller, so the present value is shown. The parameter cannot be changed when there is no power present on the drive. All drive-specific parameter numbers will NOT begin with the letter “Z”.



**Figure 4.8 Drive-Specific Parameter**

**Figure 4.8** shows the LCD display with a typical drive-specific parameter displayed and no power to the drive. In this example, the parameter displayed is only stored in the drive so the present value of the parameter is not displayed. This parameter cannot be changed when there is no power present on the drive. All drive-specific parameter numbers will NOT begin with the letter “Z”.

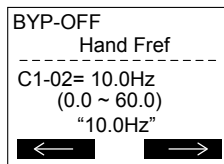

**Figure 4.9 Bypass-Specific Parameter**

**Figure 4.9** shows the LCD display with a typical bypass-specific parameter displayed. This value can be changed regardless if there is power present on the drive or not. All bypass-specific parameter numbers will begin with the letter “Z”.

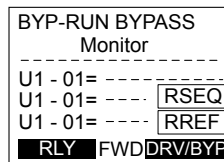

**Figure 4.10 Drive-Specific Monitors**

**Figure 4.10** shows the LCD display with drive-specific monitors displayed and no power to the drive. With no power to the drive, the bypass controller cannot retrieve the information from the drive and the present values of the monitor is replaced with dashes. Drive-specific monitor numbers begin with “U1”, “U2”, “U3”, “U4”, or “U5”.

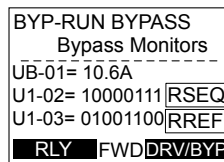

**Figure 4.11 Bypass-Specific Monitors**

**Figure 4.11** shows the LCD display with bypass-specific monitors displayed. Bypass-specific monitor numbers begin with “UB”.

## 4.3 The Drive and Programming Modes

The bypass controller has a Drive Mode to operate the motor and a Programming Mode to edit parameter settings..

**Drive Mode:** In Drive Mode the user can operate the motor and observe U Monitor parameters. Certain parameter settings cannot be edited or changed when in Drive Mode.

**Programming Mode:** In Programming Mode the user can edit and verify parameter settings and perform Auto-Tuning. When the drive is in Programming Mode, the “AUTO” and “HAND” keys are ignored.

### ■ Drive Mode Details

The following actions are possible in the Drive Mode:

- Run and stop the drive
- Monitor the operation status of the drive (frequency reference, output frequency, output current, output voltage, etc.)
- View information on an alarm
- View a history of alarms that have occurred

### ■ Programming Mode Details

The following actions are possible in the Programming Mode:

- **Parameter Setting Mode:** Access and edit all parameter settings.
- **Modified Constants:** View a list of bypass parameters that have been changed from the default values.
- **Quick Setting Group:** Access a list of commonly used parameters to simplify setup
- **Auto-Tuning Mode:** Automatically calculate and set motor parameters to optimize drive performance.

### ◆ Changing Parameter Settings or Values

This example explains changing C1-02 (Deceleration Time 1) from 30.0 seconds (default) to 20.0 seconds.

Step		Display/Result
1.	Turn on the power to the drive. The initial display appears.	
2.	Press  or  until the Parameter Setting Mode screen appears.	
3.	Press  to enter the parameter menu tree.	
4.	Press  or  to select the C parameter group.	
5.	Press  two times.	
6.	Press  or  to select parameter C1-02.	

### 4.3 The Drive and Programming Modes

Step		Display/Result
7.	Press  to view the current setting value (30.0 s). The leftmost digit flashes.	
8.	Press , , or  until the desired number is selected. "3" flashes.	
9.	Press  to change the value to 0020.0.	
10.	Press  to confirm the change.	
11.	The display automatically returns to the screen shown in Step 4.	
12.	Press  as many times as necessary to return to the initial display.	

#### ◆ Verifying Parameter Changes: Modified Constants

The Modified Constants display lists edited bypass parameters from the Programming Mode. The Modified Constants display helps determine which bypass parameter settings have been changed, and is particularly useful when replacing a Z1000 Bypass. If no bypass parameter settings have been changed, the Modified Constants display will read "None". The Modified Constants display also allows users to quickly access and re-edit any bypass parameter settings that have been changed. <1>

To check the list of edited parameters:

Step		Display/Result
1.	Turn on the power to the drive. The initial display appears.	
2.	Press  or  until the display shows "Modified Consts".	
3.	Press  to enter the list of parameters that have been edited from their original default settings. If parameters other than Z1-09 have been changed, use  or  to view them.	
4.	Press  to access the setting value. The most significant digit flashes.	

<1> The "Modified Constants" menu on the Z1000 Bypass will only display bypass parameters (Z□-□□ parameters) that have changed. The menu will not display drive parameters that have changed.

### ◆ Simplified Setup Using the Quick Setting Group

The Quick Setting Group lists only the basic parameters necessary to set up the Z1000 Bypass. This group expedites the startup process by showing only the most important bypass parameters.

#### ■ Quick Setting Parameters

Table 4.5 lists the parameters in the Quick Setting Group.

Use the Programming Mode to access parameters not displayed in the Quick Setting Group.

Table 4.5 Quick Setting Group Parameters

No.	Name	Description	Values	Page
A1-06 (127)	Application Preset	0: Standard 0: General 1: Fan 1: Fan General 2: Fan with PI Control 2: Fan PI 3: Return Fan with PI Control 3: Fan ReturnAir/PI 4: Cooling Tower Fan 4: Cooling Tower 5: Cooling Tower Fan with PI Control 5: CoolingTower/PI 6: Pump (Secondary) 6: Pump Secondary 7: Pump with PI Control 7: Pump PI	Default: 0 Range: 0 to 7	118
E1-01 (300)	Input Voltage Setting	This parameter must be set to the power supply voltage. <b>WARNING! Electrical Shock Hazard. Drive input voltage (not motor voltage) must be set in E1-01 for the protective features of the drive to function properly. Failure to do so may result in equipment damage and/or death or personal injury.</b>	Default: 230 V <3> Min.: 190 <3> Max.: 240 <3>	145
E1-05 (304)	Maximum Voltage	Only applicable when E1-03 is set to F.	Default: <2> Min.: 0.0 V Max.: 255.0 V <3>	148
E2-01 (030E)	Motor Rated Current	Sets the motor nameplate full load current in amps. Automatically set during Auto-Tuning.	Default: <2> Min.: 10% of drive rated current Max.: 200% of drive rated current <4>	149
Z1-07 (85CC) <input type="button" value="RUN"/>	Speed Reference Select	Determines the source of the Frequency Reference sent from the Bypass Controller to the Drive. 0: Operator 1: Analog Input 2: Bypass Serial 3: Option Board (CN5)	Default: 1 <5> Range: 0 to 3	197
Z1-08 (85CD) <input type="button" value="RUN"/>	Run Command Select	Determines the source of the Auto Mode Run command used by the Bypass Controller. 0: Operator 1: Bypass Controller Digital Input 2: Bypass Serial 3: Option Board (CN5)	Default: 1 Range: 0 to 3	198
Z1-09 (85CE) <input type="button" value="RUN"/>	HAND Mode Drive Speed Reference	This is the speed reference used when the Drive is running in HAND mode. Units are in Hz.	Default: 10.0 Hz <3> Min.: 0.0 Max.: 60.0	198
Z1-37 (85EA) <input type="button" value="RUN"/>	Set Time	Changes the LCD display to time setting to set the Real Time Clock. 0: Normal display 1: Displays time and date setting modes 2: Reset time <6>	Default: 0 Range: 0 to 2	206
Z3-01 (8500) <input type="button" value="RUN"/>	Serial Communications Protocol Select	Selects the bypass serial communications protocol. 0: Modbus 1: N2 2: P1 3: BACnet	Default: 3 Range: 0, 3	214
Z3-02 (8501) <input type="button" value="RUN"/>	Serial Communications Node Address Select	Selects the bypass serial communications node address.	Default: 1 Min.: 0 Max.: 127	215

### 4.3 The Drive and Programming Modes

No.	Name	Description	Values	Page
Z3-03 (8502) <input type="checkbox"/> RUN	Serial Communications Baud Rate Select	Selects the bypass serial communications speed. 0: 1200 <7> 1: 2400 <7> 2: 4800 <7> 3: 9600 4: 19200 5: 38400 6: 57600 7: 76800 8: 115200	Default: 3 Range: 0 to 8	216
Z3-04 (8503) <input type="checkbox"/> RUN	Serial Communications Parity Select	Selects the bypass serial communications parity. 0: No Parity 1: Even Parity 2: Odd Parity	Default: 0 Range: 0 to 2	216
Z3-05 (8504) <input type="checkbox"/> RUN	Serial Communications Fault Select	Selects the action to take when a serial communications fault is detected. 0: Ignore. A serial communications loss will result in no action being taken. 1: Alarm only. 2: Fault with EF0. An EF0 will be sent to the drive. If running in Bypass, the bypass contactor will NOT open and the motor will keep running. 3: Fault with EF0 and Open Contactors. An EF0 fault will be sent to the drive and the bypass contactor (K3) will be opened. 4: Alarm and run at preset speed set in Z3-10. Display AL14 alarm on Operator	Default: 1 Range: 0 to 4	216
Z3-06 (8505) <input type="checkbox"/> RUN	Serial Communications Fault Time Select	Sets the time allowed to elapse since receiving serial communications before triggering a communications fault. A setting of 0.0 will never time out.	Default: 2.0 s Min.: 0.0 Max.: 99.9	444
Z3-07 (8506) <input type="checkbox"/> RUN	Serial Communications Receive to Transmit Wait Time	Sets the time to delay a serial communications response to a serial communications command. This parameter will only appear when Z3-01 = 0, 1, or 2.	Default: 5 ms Min.: 0 Max.: 99 ms	444
Z3-08 (8507) <input type="checkbox"/> RUN	BACnet Device Object Identifier 0	BACnet only. Sets the least significant word of 22-bit virtual address. This parameter will appear only when Z3-01 = 3.	Default: 1 Min.: 0 Max.: FFFF	217
Z3-09 (8508) <input type="checkbox"/> RUN	BACnet Device Object Identifier 1	BACnet only. Sets the most significant word of 22-bit virtual address. This parameter will appear only when Z3-01 = 3.	Default: 0 Min.: 0 Max.: 003F	217

- <1> Available in Quick Setting Group in bypass controller software versions VST800299 and earlier.
- <2> Default setting is dependent on parameter o2-04, Drive Model Selection.
- <3> Values shown are specific to 208 Vac. Double the value for 480 Vac.
- <4> The number of decimal places in the parameter value depends on the drive model. [Refer to Defaults by Drive Model on page 372](#) for details.
- <5> Default value is 0 in bypass controller software versions VST800297 and earlier.
- <6> Setting 2 is available in bypass controller software versions VST800298 and later.
- <7> Selecting setting 0, 1, or 2 will trigger an oPE29 error when using BACNet communication in bypass controller software versions VST800400 and later.

## 4.4 Powering Up the Drive

### ◆ Powering Up the Drive and Operation Status Display



#### ■ Powering Up the Drive

Review the following checklist before turning the power on.

Item to Check	Description
Power supply voltage	208 Vac: Three-phase 200 to 240 Vac 50/60 Hz 480 Vac: Three-phase 380 to 480 Vac 50/60 Hz
	Properly wire the power supply input terminals (L1, L2, L3).
	Check for proper grounding of drive and motor.
Drive output terminals and motor terminals	Properly wire drive output terminals T1, T2, and T3 with motor terminals U, V, and W.
Control circuit terminals	Check control circuit terminal connections.
Drive control terminal status	Open all control circuit terminals (off).
Status of the load and connected machinery	Decouple the motor from the load.

#### ■ Status Display

When the power supply to the drive is turned on, the HOA keypad lights will appear as follows:

Status	Name	Description
Normal Operation		The data display area displays the frequency reference. <b>[DRV]</b> is lit.
Fault	 External fault (example)	Data displayed varies by the type of fault. <i>Refer to Fault Displays, Causes, and Possible Solutions on page 229</i> for more information. <b>[ALM]</b> and <b>[DRV]</b> are lit.

# 4.5 Start-Up Procedure

Follow the steps and procedures outlined below to help ensure proper start-up of the Z1000 Bypass.

### ◆ Bypass Start-Up Preparation

1. Remove power to the Z1000 Bypass and verify using a multimeter. Follow all appropriate lockout/tagout procedures.

**WARNING! Electrical Shock Hazard.** Do not remove covers or touch circuit boards while the power is on. Failure to comply could result in death or serious injury.

2. Record the motor nameplate information and verify that the input voltage matches the Z1000 Bypass rating. Verify that the motor rated FLA does not exceed the rated output rating of the bypass unit, and verify that the motor FLA falls in the rated range of the thermal overload relay (if present).
3. Determine which type of main input disconnect is provided on the Z1000 Bypass.

The standard Z1000 Bypass includes a non-fusible disconnect switch that does not provide branch circuit protection. Branch circuit protection is required to be installed according to applicable local codes and the requirements listed on the Z1000 Bypass nameplate. Yaskawa recommends semiconductor fusing to ensure to 100 kAIC SCCR panel rating and is specified on the nameplate of the Z1000 Bypass.

**WARNING! Fire Hazard.** Branch Circuit protection is required to be installed according to applicable local codes and the requirements listed on the Z1000 Bypass nameplate. Failure to comply could result in fire and damage to the bypass and drive or injury to personnel. The Z1000 Bypass is suitable for use on a circuit capable of delivering not more than 100,000 RMS symmetrical amperes, 208 Vac and 480 Vac with the circuit breaker option or when protected by class J or class L fuses as specified on the Z1000 Bypass nameplate. Consult factory with questions.

The Z1000 Bypass Option M provides an input circuit breaker. If provided, the adjustable trip level must be set using the two dials located on the circuit breaker. The dial marked "FLA" sets the breaker to match the motor FLA. Use a small straight-edge screwdriver and adjust to the appropriate current level. The other dial sets the inrush level. Make sure this dial is set to "Auto 1" (factory setting).

4. Verify that three-phase line power is connected to input disconnect device.
5. Verify that the grounding terminal of the Z1000 Bypass is attached to the appropriate building ground circuit.
6. Verify that wiring connections are properly terminated and connected to appropriate circuits at PCB A2 using the Z1000 connection diagram. [Refer to Standard Connection Diagram on page 52](#) for details.

Please note the following in regards to the safety circuit (DI-2, terminal TB2-2) and the BAS interlock circuit (DI-3, terminal TB3-3):

#### Safety Interlock Circuit

DI-2 (terminal TB2-2) is provided to connect safety devices in a normally-closed series circuit, such as: freeze up thermostats, smoke/fire sensors, high pressure limits, temperature limits, or vibration detectors.

The HOA keypad will display a Safety Open fault if a N.C. safety circuit is not closed between DI-2 (TB2-2) and IG24 (TB2-10) on PCB A2 at power-up with a Run command in HAND or AUTO mode. An open circuit between DI-2 (TB2-2) and IG24 (TB2-10) will prevent bypass operation.

Take one of the following steps to ensure proper operation prior to startup:

Install a N.C. safety circuit between DI-2 (TB2-2) and IG24 (TB2-10) on PCB A2.

Install a jumper between DI-2 (TB2-2) and IG24 (TB2-10) on PCB A2.

#### Building Automation System Interlock Circuit (Drive and Bypass Enable Input)

The HOA keypad will display "INTRLOCK OPN" to indicate a BAS Interlock fault is a N.C. safety circuit is not closed between DI-3 (TB2-3) and IG24 (TB2-10) on PCB A2 at power-up with a Run command in HAND or AUTO mode. An open circuit between DI-3 (TB2-3) and IG24 (TB2-10) will prevent bypass operation.

This condition is a fault and will prevent drive and bypass operation.

Take one of the following steps to ensure proper operation prior to startup:

Install a N.C. BAS Interlock Circuit/Damper Interlock between DI-3 (TB2-3) and IG24 (TB2-10) on PCB A2.

Install a jumper between DI-3 (TB2-3) and IG24 (TB2-10) on PCB A2.

7. Verify that the motor is wired for the application voltage if it is a dual voltage motor.
8. Connect the motor to the output terminals of the motor overload.
9. Set the motor overload for the proper FLA of the motor.
10. Verify that the motor ground is connected to the Z1000 Bypass drive ground terminal.



11. Record all other connections to the Z1000 Bypass by terminal number to determine if special programming of any of the following is required:
  - Multi-function Digital Inputs – Bypass control board TB2 (A2)
  - Multi-function Digital Outputs – Bypass control board TB1 (A2)
  - Analog Inputs – Drive control board (A1)
  - Analog Outputs – Drive control board (A1)
  - Differential PI control – Bypass control board (A2)
  - Serial Communications – Bypass control board TB3 (A2)
12. Verify that all control wiring is run in separate conduit from motor or line power and route digital output wiring exceeding 24 V in conduit separate from other control wiring.
13. Verify that the building automation system logic is ready for the start, stop, and speed command functions.

**■ Precautions for Connected Machinery**







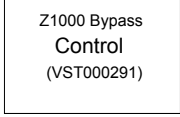
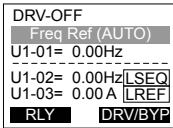

**WARNING!** Sudden Movement Hazard. Clear all personnel from the drive, motor, and machine area before applying power. System may start unexpectedly upon application of power, causing death or serious injury.

**WARNING!** Sudden Movement Hazard. Always check the operation of any fast stop circuits after they are wired. Fast stop circuits are required to provide safe and quick shutdown of the drive. Prepare to initiate an emergency stop during the test run. Operating a drive with untested emergency circuits could result in death or serious injury.

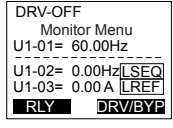

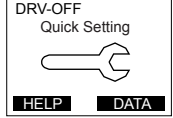

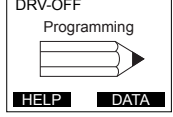
- The motor should come to a complete stop without problems.
- Connect the load and machinery to the motor.
- Fasten all installation screws properly and check that the motor and connected machinery are held in place.

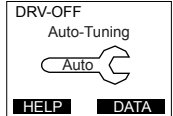
**◆ Bypass Start-Up Procedure**





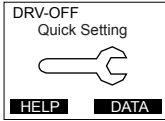

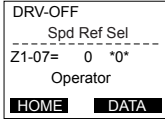
After completing the steps in *Bypass Start-Up Preparation*, replace all Z1000 Bypass and drive covers. Connect one end of the HOA keypad cable to the Bypass control board A2 and one end to the door-mounted HOA keypad.

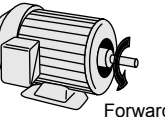

Step		Display/Result
1.	Remove any power source lockouts on the Z1000 Bypass then turn the main input disconnect handle clockwise to energize the Z1000 Bypass. Refer to <i>Input Disconnect Switch on page 31</i> for details. Use a multimeter to check all three-phase voltages for proper levels and balance and record these levels for future reference. During this sequence, the control logic will briefly (< 3 s) perform a self-test to ensure proper operation.	 → 
2.	The keypad will now display the main startup screen showing that the Z1000 Bypass is in Drive mode and currently OFF. It also shows that the Bypass is in “AUTO” mode while displaying the frequency reference.	
3.	Press  one time to display the Monitor Menu. All available drive and bypass monitors can be viewed from this menu. Refer to <i>Parameter List on page 327</i> for a complete list of monitors.	
4.	Press  one time to display the Quick Settings Menu. This is a condensed parameter set specifically selected for the initial drive start-up.	
5.	Press  one time to display the Programming Menu. All available drive and bypass parameters can be accessed through this menu.	
6.	Press  one time to display the Auto-Tuning Menu. The Auto-Tuning function tunes the drive set-up to the characteristics of the motor to which it is applied. Auto-Tuning is essential if bi-directional Speed Search is required and enabled for the application.	

## 4.5 Start-Up Procedure

Step		Display/Result
7.	Press  or  until the Quick Settings Menu screen is displayed.	
8.	Press  to access the Quick Settings parameters and adjust each parameter to the appropriate setting for the application. <i>Refer to Quick Setting Parameters on page 101</i> for the list of parameters available in the Quick Setting Menu.	

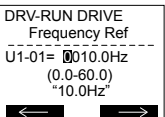
### Checking the motor rotation in Drive and Bypass Modes.

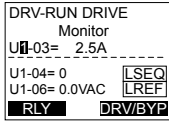
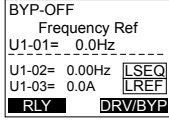
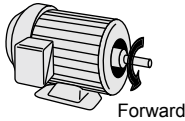
Step		Display/Result
<b>Motor Rotation in Drive Mode</b>		
1.	Press  to give the drive a Run command from HAND mode. The HAND light will turn on and the motor will rotate at the value set to parameter Z1-09 (10 Hz default).	
2.	Ensure the motor is rotating in the correct direction and that no faults or alarms occur.	
3.	If the direction of motor rotation is incorrect, press  to stop the motor. The HAND light turns OFF and the motor coasts to stop. Skip to step 6 If the direction of motor rotation is correct.	
4.	Turn off the power to the Z1000 Bypass. <b>WARNING! Electrical Shock Hazard. Do not touch any terminals before the capacitors have fully discharged. Failure to comply could result in death or serious injury. Before servicing, disconnect all power to the equipment. The internal capacitor remains charged even after the power supply is turned off. The charge indicator LED will extinguish when the DC bus voltage is below 50 Vdc. To prevent electric shock, wait for at least the time specified on the warning label, once all indicators are OFF, measure for unsafe voltages to confirm the drive is safe prior to servicing.</b> Switch the wires for T1 and T2 on the output terminals of the motor overload relay. Retighten the terminal lugs and reapply power.	-
5.	Reapply the power, press  and re-check the rotation direction.	-
6.	Verify that the system is ready to operate at full speed by making sure that the building automation system logic is ready for the start, stop, and speed command functions.	-
7.	Press  to increase the frequency reference in increments of 10 Hz, verifying smooth operation at all speeds. For each frequency, check the drive output current using monitor U1-03. The current should be well below the motor rated current.	

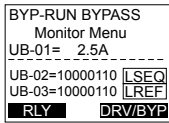
Step			Display/Result
8.	Press <b>F1</b> , <b>F2</b> , or <b>RESET</b> to navigate the cursor through the numerical positions. Use <b>▲</b> and <b>▼</b> to change the value of the selected numerical place.	-	-
9.	Press <b>ENTER</b> to confirm the new frequency reference; the drive will begin to accelerate or decelerate.	-	-
10.	Check the motor current using U1-03 then measure the output voltage (Line-to-Line and Line-to-Ground) using a multimeter and record the values for future reference. Press <b>OFF</b> to stop the motor.	➔	
<b>Motor Rotation in Bypass Mode</b>			
11.	Press <b>F2</b> to toggle to the Bypass Mode. The keypad display should show <b>BYP-OFF</b> if the device is ready for Bypass operation.	➔	
12.	Bump the motor by pressing <b>HAND</b> then quickly pressing <b>OFF</b> . Ensure the motor is rotating in the correct direction and that no faults or alarms occur.	➔	
13.	If the direction of motor rotation is incorrect, press <b>OFF</b> to stop the motor. The <b>HAND</b> light turns OFF and the motor coasts to stop. Skip to step 15 if the direction of motor rotation is correct.	➔	
14.	Turn off the power to the Z1000 Bypass. <b>WARNING! Electrical Shock Hazard. Do not touch any terminals before the capacitors have fully discharged. Failure to comply could result in death or serious injury. Before servicing, disconnect all power to the equipment. The internal capacitor remains charged even after the power supply is turned off. The charge indicator LED will extinguish when the DC bus voltage is below 50 Vdc. To prevent electric shock, wait for at least the time specified on the warning label, once all indicators are OFF, measure for unsafe voltages to confirm the drive is safe prior to servicing.</b> Switch the wires for L1 and L2 on the Bypass input disconnect device. Re-tighten the terminal lugs and reapply power.	-	-
15.	Run the motor in Bypass Mode using <b>HAND</b> and check the motor current using UB-01. Then measure the output voltage (Line-to-Line and Line-to-Ground) using a multimeter and record the values for future reference.	➔	
16.	The Z1000 Bypass should operate normally. Press <b>OFF</b> to stop the motor. The <b>HAND</b> light is OFF and the motor coasts to stop.	-	-

### 4.6 Application Selection

Several Application Presets are available to facilitate drive setup for commonly used applications. Selecting one of these Application Presets automatically assigns functions to the input and output terminals, and sets certain parameters to values appropriate for the application that was selected.

**Note:** An Application Preset can only be selected if all drive parameters are on at their original default settings. It may be necessary to initialize the drive by setting Z1-01 to 1 or 3 prior to selecting an Application Preset.

**WARNING!** Confirm the drive I/O signals and external sequence before performing a test run. Setting parameter A1-06 may change the I/O terminal function automatically from the default setting. Failure to comply may result in death or serious injury.

No.	Parameter Name	Setting Range	Default
A1-06	Application Presets	0: Standard 1: Fan 2: Fan with PI Control 3: Return Fan with PI Control 4: Cooling Tower Fan 5: Cooling Tower Fan with PI Control 6: Pump (Secondary) 7: Pump with PI Control	0

#### ◆ Setting 1: Fan Application

Table 4.6 Fan: Parameter Settings

No.	Name	Default Setting
b1-03	Stopping Method Selection	1: Coast to Stop
b1-04	Reverse Operation Selection	1: Reverse operation disabled
C1-01	Acceleration Time 1	60 s
L5-01	Number of Auto Restart Attempts	10
L6-01	Torque Detection Selection 1	5: UL3 at speed agree (Alarm)

#### ◆ Setting 2: Fan with PI Control Application

Table 4.7 Fan with PI Control: Parameter Settings

No.	Parameter Name	Default Setting
b1-03	Stopping Method Selection	1: Coast to Stop
b1-04	Reverse Operation Selection	1: Reverse operation disabled
b5-01	PI Function Setting	1: Output frequency = PI output 1
b5-03	Integral Time Setting (I)	30 s
b5-08	PI Primary Delay Time Constant	2 s
b5-13	PI Feedback Low Detection Level	2%
b5-14	PI Feedback Low Detection Time	25 s
C1-01	Acceleration Time 1	60 s
L5-01	Number of Auto Restart Attempts	10
L6-01	Stall Prevention Selection during Deceleration	5: UL3 at speed agree (Alarm)

#### ◆ Setting 3: Return Fan with PI Control Application

Table 4.8 Return Fan with PI Control: Parameter Settings

No.	Parameter Name	Default Setting
b1-03	Stopping Method Selection	1: Coast to Stop
b1-04	Reverse Operation Selection	1: Reverse operation disabled
b5-01	PI Function Setting	1: Output frequency = PI output 1
b5-03	Integral Time Setting (I)	30 s
b5-08	PI Primary Delay Time Constant	2 s
b5-13	PI Feedback Low Detection Level	2%
b5-14	PI Feedback Low Detection Time	25 s

No.	Parameter Name	Default Setting
C1-01	Acceleration Time 1	60 s
H3-01	Terminal A1 Signal Level Selection	2: 4 to 20 mA
H3-02	Terminal A1 Function Selection	B: PI feedback
H3-10	Terminal A2 Function Selection	16: Differential PI feedback
L5-01	Number of Auto Restart Attempts	10
L6-01	Stall Prevention Selection during Deceleration	5: UL3 at speed agree (Alarm)
o1-07	Second Line Monitor Selection	505: PI Differential Feedback

## ◆ Setting 4: Cooling Tower Fan Application

Table 4.9 Cooling Tower Fan: Parameter Settings

No.	Parameter Name	Default Setting
b1-03	Stopping Method Selection	1: Coast to Stop
b1-04	Reverse Operation Selection	0: Reverse operation enabled
b2-09 </>	Motor Pre-Heat Current 2	10%
C1-01	Acceleration Time 1	60 s
d2-03	Master Speed Reference Lower Limit	30%
H1-07	Multi-Function Digital Input Terminal S7 Function Selection	60: Motor Pre-Heat 1
L5-01	Number of Auto Restart Attempts	10
L6-01	Stall Prevention Selection during Deceleration	5: UL3 at speed agree (Alarm)

<1> Details on this function can be found in the standard Z1000 Programming Manual (SIEPC71061645) at [www.yaskawa.com](http://www.yaskawa.com).

## ◆ Setting 5: Cooling Tower Fan with PI Control Application

Table 4.10 Cooling Tower Fan with PI Control: Parameter Settings

No.	Parameter Name	Default Setting
b1-03	Stopping Method Selection	1: Coast to Stop
b1-04	Reverse Operation Selection	0: Reverse operation enabled
b2-09 </>	Motor Pre-Heat Current 2	10%
b5-01	PI Function Setting	1: Output frequency = PI output 1
b5-03	Integral Time Setting (I)	30 s
b5-08	PI Primary Delay Time Constant	2 s
b5-09	PI Output Level Selection	1: Reverse Output
b5-13	PI Feedback Low Detection Level	2%
b5-14	PI Feedback Low Detection Time	25 s
b5-15	PI Sleep Function Start Level	10.8 Hz
b5-16	PI Sleep Delay Time	25.5 s
C1-01	Acceleration Time 1	60 s
d2-03	Master Speed Reference Lower Limit	30%
H1-07	Multi-Function Digital Input Terminal S7 Function Selection	60: Motor Pre-Heat 1
L5-01	Number of Auto Restart Attempts	10
L6-01	Stall Prevention Selection during Deceleration	5: UL3 at speed agree (Alarm)

<1> Details on this function can be found in the standard Z1000 Programming Manual (SIEPC71061645) at [www.yaskawa.com](http://www.yaskawa.com).

## 4.6 Application Selection

### ◆ Setting 6: Pump (Secondary) Application

Table 4.11 Pump (Secondary): Parameter Settings

No.	Parameter Name	Default Setting
b1-04	Reverse Operation Selection	1: Reverse operation disabled
C1-01	Acceleration Time 1	20 s
d2-03	Master Speed Reference Lower Limit	20%
L5-01	Number of Auto Restart Attempts	10
L6-01	Stall Prevention Selection during Deceleration	5: UL3 at speed agree (Alarm)

### ◆ Setting 7: Pump with PI Control Application

Table 4.12 Pump with PI Control: Parameter Settings

No.	Parameter Name	Default Setting
b1-04	Reverse Operation Selection	1: Reverse operation disabled
b5-01	PI Function Setting	1: Enabled (PI output becomes output frequency reference)
b5-03	Integral Time Setting (I)	15 s
b5-08	PI Primary Delay Time Constant	10.0 s
b5-13	PI Feedback Low Detection Level	2%
b5-14	PI Feedback Low Detection Time	25 s
b5-15	PI Sleep Function Start Level	72%
b5-16	PI Sleep Delay Time	25.5 s
C1-01	Acceleration Time 1	20 s
d2-03	Master Speed Reference Lower Limit	20%
L5-01	Number of Auto Restart Attempts	10
L6-01	Stall Prevention Selection during Deceleration	5: UL3 at speed agree (Alarm)

## 4.7 Auto-Tuning

### ◆ Types of Auto-Tuning

Refer to the tables below to select the type of Auto-Tuning that best suits the application.

#### ■ Auto-Tuning for Induction Motors

This feature automatically sets the V/f pattern and motor parameters E1-□□ and E2-□□ for an induction motor.

**Table 4.13 Types of Auto-Tuning for Induction Motors**

Type	Setting	Application Conditions and Benefits	Control Mode
			V/f
<b>Stationary Auto-Tuning for Line-to-Line Resistance</b>	T1-01 = 2	<ul style="list-style-type: none"> <li>The drive is used in V/f Control and other Auto-Tuning selections are not possible.</li> <li>Drive and motor capacities differ.</li> <li>Tunes the drive after the cable between the drive and motor has been replaced with a cable over 50 m long. Assumes Auto-Tuning has already been performed.</li> <li>Should not be used for any vector control modes unless the motor cable has changed.</li> </ul>	YES
<b>Rotational Auto-Tuning for V/f Control</b>	T1-01 = 3	<ul style="list-style-type: none"> <li>Recommended for applications using Speed Estimation Speed Search or using the Energy Saving function in V/f Control.</li> <li>Assumes motor can rotate while Auto-Tuning is executed. Increases accuracy for certain functions like torque compensation, slip compensation, Energy Saving, and Speed Search.</li> </ul>	YES

**Table 4.14** lists the data that must be entered for Auto-Tuning. Make sure this data is available before starting Auto-Tuning. The necessary information is usually listed on the motor nameplate or in the motor test report provided by the motor manufacturer.

**Table 4.14 Auto-Tuning Input Data**

Input Value	Input Parameter	Unit	Tuning Type (T1-01)	
			2 Line-to-Line Resistance	3 Rotational for V/f Control
Motor rated power	T1-02	kW	YES	YES
Motor rated voltage	T1-03	Vac	–	YES
Motor rated current	T1-04	A	YES	YES
Motor rated frequency	T1-05	Hz	–	YES
Number of motor poles	T1-06	-	–	YES
Motor rated Speed	T1-07	r/min	–	YES
Motor iron loss	T1-11	W	–	YES

### ◆ Before Auto-Tuning the Drive

Check the items below before Auto-Tuning the drive.

#### ■ Basic Auto-Tuning Preparations

- Auto-Tuning requires the user to input data from the motor nameplate or motor test report. Make sure this data is available before Auto-Tuning the drive.
- For best performance, the drive input supply voltage must be at least equal to or greater than the motor rated voltage.
 

**Note:** Better performance is possible when using a motor with a base voltage that is lower than the input supply voltage (20 V for 208 V models and 40 V for 480 V models). This is particularly important when operating the motor above 90% of base speed, where high torque precision is required.
- To cancel Auto-Tuning, press the OFF key on the HOA keypad.
- When using a motor contactor, make sure it is closed throughout the Auto-Tuning process.

## 4.7 Auto-Tuning

Table 4.15 Auto-Tuning Input Data

Motor Type	Auto-Tuning Type	Digital Input	Digital Output
Induction Motor	Stationary Auto-Tuning for Line-to-Line Resistance	Digital input functions are disabled.	Maintains the status at the start of Auto-Tuning
	Rotational Auto-Tuning for V/f Control		Functions the same as during normal operation

### ■ Notes on Stationary Auto-Tuning

Stationary Auto-Tuning modes analyze motor characteristics by injecting current into the motor for approximately one minute.

**WARNING! Electrical Shock Hazard.** When executing stationary Auto-Tuning, voltage is applied to the motor before the motor rotates. Do not touch the motor until Auto-Tuning is completed. Failure to comply may result in injury or death from electrical shock.

**WARNING! Sudden Movement Hazard.** If installed, do not release the mechanical brake during Stationary Auto-Tuning. Inadvertent brake release may cause damage to equipment or injury to personnel. Ensure that the mechanical brake release circuit is not controlled by the drive multi-function digital outputs.

### Stationary Auto-Tuning for Line-to-Line Resistance

- Perform when entering motor data manually while using motor cables longer than 50 m.
- If the motor cables have been replaced with cables more than 50 m long after Auto-Tuning has already been performed, use Stationary Auto-Tuning for line-to-line resistance.

### ◆ Auto-Tuning Interruption and Fault Codes

If tuning results are abnormal or the OFF key is pressed before completion, Auto-Tuning will be interrupted and a fault code will appear on the HOA keypad.

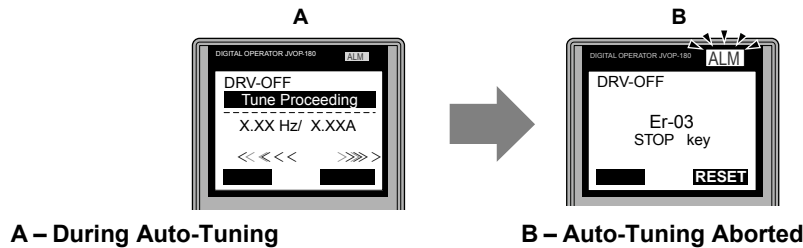

Figure 4.12 Auto-Tuning Aborted Display



### ◆ Auto-Tuning Operation Example

The following example demonstrates Rotational Auto-Tuning for V/f.

#### ■ Selecting the Type of Auto-Tuning

Step		Display/Result
1.	Turn on the power to the drive. The initial display appears.	
2.	Press  or  until the Auto-Tuning display appears.	
3.	Press  to begin setting parameters.	
4.	Press  to display the value for T1-01.	



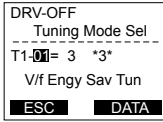







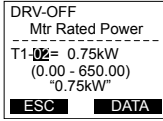

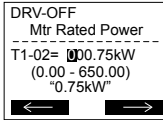
Step			Display/Result
5.	Save the setting by pressing  .	→	
6.	The display automatically returns to the display shown in Step 3.	→	

## ■ Enter Data from the Motor Nameplate

After selecting the type of Auto-Tuning, enter the data required from the motor nameplate.

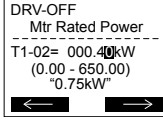
**Note:** These instructions continue from Step 6 in “Selecting the Type of Auto-Tuning”.

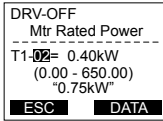
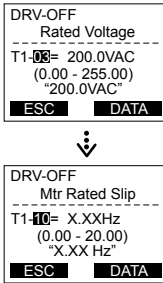
Step			Display/Result
1.	Press  to access the motor output power parameter T1-02.	→	
2.	Press  to view the default setting.	→	
3.	Press  left,  right,  ,  , and  to enter the motor power nameplate data in kW.	→	
4.	Press  to save the setting.	→	
5.	The display automatically returns to the display in Step 1.	→	
6.	Repeat Steps 1 through 5 to set the following parameters: <ul style="list-style-type: none"> <li>• T1-03, Motor Rated Voltage</li> <li>• T1-04, Motor Rated Current</li> <li>• T1-05, Motor Base Frequency</li> <li>• T1-06, Number of Motor Poles</li> <li>• T1-07, Motor Base Frequency</li> </ul>	→	

- Note:**
1. For details on each setting, [Refer to T1: Parameter Settings during Induction Motor Auto-Tuning on page 114.](#)
  2. To execute Stationary Auto-Tuning for line-to-line resistance only, set parameters T1-02 and T1-04.

## 4.7 Auto-Tuning

### ■ Starting Auto-Tuning



**WARNING! Sudden Movement Hazard.** The drive and motor may start unexpectedly during Auto-Tuning, which could result in death or serious injury. Ensure the area surrounding the drive motor and load are clear before proceeding with Auto-Tuning.

**WARNING! Electrical Shock Hazard.** High voltage will be supplied to the motor when Stationary Auto-Tuning is performed even with the motor stopped, which could result in death or serious injury. Do not touch the motor until Auto-Tuning has been completed.

**NOTICE:** Rotational Auto-Tuning will not function properly if the motor cannot spin freely. Failure to comply could result in improper operation of the drive. Ensure the motor can freely spin before beginning Auto-Tuning.

Enter the required information from the motor nameplate. Press  to proceed to the Auto-Tuning start display.

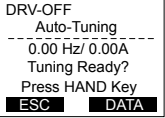
**Note:** These instructions continue from Step 6 in “Enter Data from the Motor Nameplate”.

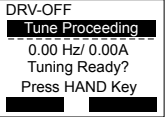
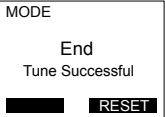
Step			Display/Result
1.	After entering the data listed on the motor nameplate, press  to confirm.	→	
2.	Press  to activate Auto-Tuning. <b>DRV</b> flashes. The drive begins by injecting current into the motor for about 1 min, and then starts to rotate the motor.	→	
3.	Auto-Tuning finishes in approximately one to two minutes.	→	

### ◆ T1: Parameter Settings during Induction Motor Auto-Tuning

The T1-□□ parameters set the Auto-Tuning input data for induction motor tuning.

**Note:** For motors operating in the field weakening range, first perform the Auto-Tuning with the base data. After Auto-Tuning is complete, change E1-04, Maximum Output Frequency, to the desired value.

#### ■ T1-01: Auto-Tuning Mode Selection

Sets the type of Auto-Tuning to be used. Refer to the User Manual packaged with the drive for details on the different types of Auto-Tuning.

No.	Name	Setting Range	Default
T1-01	Auto-Tuning Mode Selection	2, 3	2

**Setting 2: Stationary Auto-Tuning for Line-to-Line Resistance**

**Setting 3: Rotational Auto-Tuning for V/f Control Energy Saving**

#### ■ T1-02: Motor Rated Power

Sets the motor rated power according to the motor nameplate value.

**Note:** Use the following formula to convert HP to kW: kW = HP x 0.746.

No.	Name	Setting Range	Default
T1-02	Motor Rated Power	0.00 to 650.00 kW	Determined by o2-04

#### ■ T1-03: Motor Rated Voltage

Sets the motor rated voltage according to the motor nameplate value. Enter the voltage base speed when the motor operates above base speed. Enter the voltage needed to operate the motor under no-load conditions at rated speed to T1-03.

No.	Name	Setting Range	Default
T1-03	Motor Rated Voltage	0.0 to 255.0 V <1>	200.0 V <1>

<1> Values shown are specific to 208 Vac. Double the value for 480 Vac.

### ■ T1-04: Motor Rated Current

Sets the motor rated current according to the motor nameplate value. Enter the current at the motor base speed.

No.	Name	Setting Range	Default
T1-04	Motor Rated Current	10.0 to 300.0% of drive rated current	Determined by o2-04

### ■ T1-05: Motor Base Frequency

Sets the motor rated frequency according to the motor nameplate value. If a motor with an extended speed range is used or the motor is used in the field weakening area, enter the maximum frequency to E1-04 after Auto-Tuning is complete.

No.	Name	Setting Range	Default
T1-05	Motor Base Frequency	0.0 to 240.0 Hz	60.0 Hz

### ■ T1-06: Number of Motor Poles

Sets the number of motor poles according to the motor nameplate value.

No.	Name	Setting Range	Default
T1-06	Number of Motor Poles	2 to 48	4

### ■ T1-07: Motor Base Speed

Sets the motor rated speed according to the motor nameplate value. Enter the speed at base frequency when using a motor with an extended speed range or if using the motor in the field weakening area.

No.	Name	Setting Range	Default
T1-07	Motor Base Speed	0 to 14400 r/min	1750 r/min

### ■ T1-11: Motor Iron Loss

Provides iron loss information to determine the Energy Saving coefficient. T1-11 will first display the value for the motor iron loss that the drive automatically calculated when the motor capacity was entered to T1-02. Enter the motor iron loss value listed to T1-11 if the motor test report is available.

No.	Name	Setting Range	Default
T1-11	Motor Iron Loss	0 to 65535 W	14 W

**This Page Intentionally Blank**

# Programming

---

5.1	A: INITIALIZATION.....	118
5.2	B: APPLICATION.....	119
5.4	C: TUNING.....	139
5.5	D: REFERENCE SETTINGS.....	142
5.6	E: MOTOR PARAMETERS.....	145
5.7	F: OPTIONS.....	150
5.8	H: TERMINAL FUNCTIONS.....	151
5.9	L: PROTECTION FUNCTIONS.....	168
5.10	N: SPECIAL ADJUSTMENTS.....	181
5.11	O: OPERATOR-RELATED SETTINGS.....	183
5.12	S: SPECIAL PARAMETERS.....	187
5.13	T: MOTOR TUNING.....	194
5.14	U: MONITOR PARAMETERS.....	195
5.15	Z: BYPASS PARAMETERS.....	196

# 5.1 A: Initialization

The initialization group contains parameters associated with initial drive setup, including parameters involving the display language, access levels, initialization, and password.

---

## ◆ A1: Initialization

### ■ A1-06: Application Preset

Several Application Presets are available to facilitate drive setup for commonly used applications. Selecting one of these Application Presets automatically assigns functions to the input and output terminals and sets a predefined group of parameters to values appropriate for the selected application.

*Refer to [Application Selection on page 108](#) for details on parameter A1-06.*

## 5.2 b: Application

### ◆ b1: Operation Mode Selection

#### ■ b1-03: Stopping Method Selection

Selects how the drive stops the motor when the Run command is removed or when a Stop command is entered.

No.	Parameter Name	Setting Range	Default
b1-03	Stopping Method Selection	0 to 3	1

#### Setting 0: Ramp to Stop

When the Run command is removed, the drive will decelerate the motor to stop. The deceleration rate is determined by the active deceleration time. The default deceleration time is set to parameter C1-02.

When the output frequency falls below the level set in parameter b2-01, the drive will start DC injection or Short Circuit Braking depending on the selected control mode.

#### Setting 1: Coast to Stop

When the Run command is removed, the drive will shut off its output and the motor will coast (uncontrolled deceleration) to stop. The stopping time is determined by the inertia and the friction in the driven system.

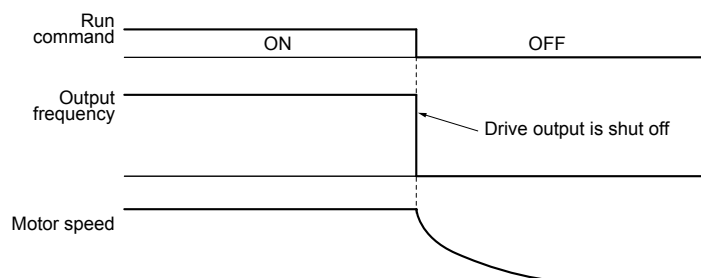

Figure 5.1 Coast to Stop

**Note:** After a stop is initiated, any subsequent Run command entered will be ignored until the minimum baseblock time (L2-03) has expired. Do not enter Run command until it has come to a complete stop. Use DC Injection at Start ([Refer to b2-03: DC Injection Braking Time at Start on page 122](#)) or Speed Search ([Refer to b3: Speed Search on page 122](#)) to restart the motor before it has completely stopped.

#### Setting 2: DC Injection Braking to Stop

When the Run command is removed, the drive will enter baseblock (turn off its output) for the minimum baseblock time (L2-03). When the minimum baseblock time has expired, the drive will inject the amount DC current set in parameter b2-02<1> into the motor windings to brake the motor. The stopping time in DC Injection Braking to Stop is significantly faster compared to Coast to Stop.

<1> Details on this function can be found in the standard Z1000 Programming Manual (SIEPC71061645) at [www.yaskawa.com](http://www.yaskawa.com).

## 5.2 b: Application

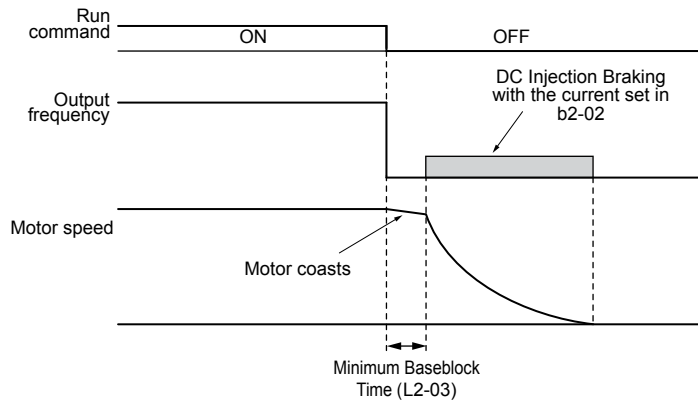

**Figure 5.2 DC Injection Braking to Stop**

DC Injection Braking time is determined by the value set to b2-04 and the output frequency at the time the Run command is removed. It can be calculated by:

$$\text{DC Injection brake time} = \frac{(\text{b2-04}) \times 10 \times \text{Output frequency}}{\text{Maximum output frequency (E1-04)}}$$

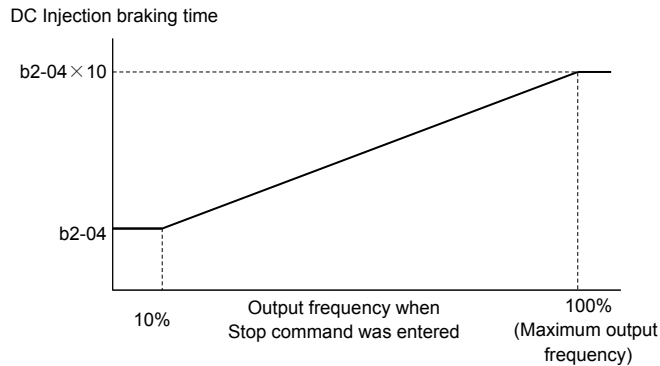
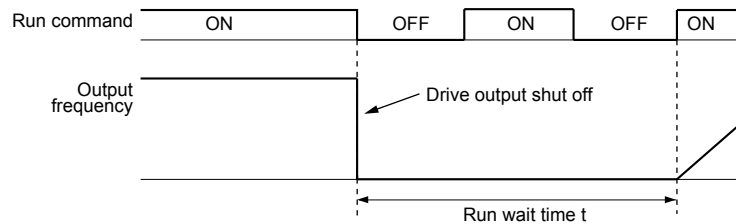

**Figure 5.3 DC Injection Braking Time Depending on Output Frequency**

**Note:** If an overcurrent (oC) fault occurs during DC Injection Braking to Stop, lengthen the minimum baseblock time (L2-03) until the fault no longer occurs.

### Setting 3: Coast with Timer

When the Run command is removed, the drive will turn off its output and the motor will coast to stop. The drive will not start if a Run command is input before the time  $t$  (C1-02) has expired. Cycle the Run command that was activated during time  $t$  after  $t$  has expired to start the drive.



**Figure 5.4 Coast with Timer**

The wait time  $t$  is determined by the output frequency when the Run command is removed and by the active deceleration time.



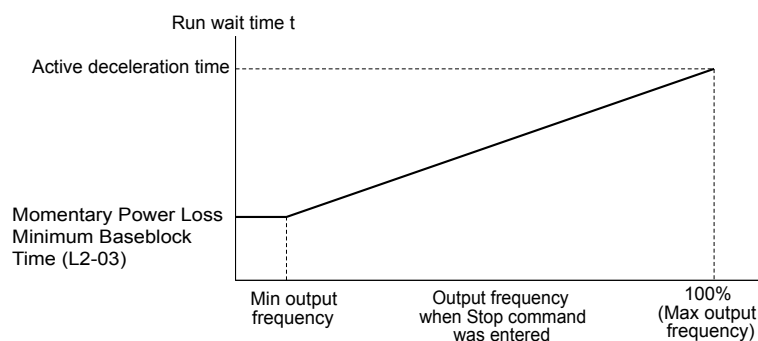

Figure 5.5 Run Wait Time Depending on Output Frequency

### ■ b1-04: Reverse Operation Selection

Enables and disables Reverse operation. For some applications, reverse motor rotation is not appropriate and may cause problems (e.g., air handling units, pumps, etc.).

No.	Parameter Name	Setting Range	Default
b1-04	Reverse Operation Selection	0, 1	1

#### Setting 0: Reverse Enabled

Possible to operate the motor in both forward and reverse directions.

#### Setting 1: Reverse Disabled

Drive disregards a Reverse run command or a negative frequency reference.

### ◆ b2: DC Injection Braking and Short Circuit Braking

These parameters determine operation of the DC Injection Braking, Zero Speed Control, and Short Circuit Braking features.

#### ■ b2-01: DC Injection Braking Start Frequency

Active when “Ramp to Stop” is selected as the stopping method (b1-03 = 0).

No.	Name	Setting Range	Default
b2-01	DC Injection Braking Start Frequency	0.0 to 10.0 Hz	0.5 Hz

b2-01 sets the starting frequency for DC Injection Braking at Stop. When the output frequency falls below the setting of b2-01, DC Injection Braking is enabled for the time set in parameter b2-04.

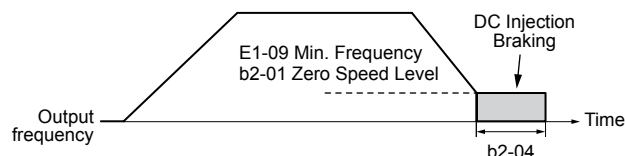

Figure 5.6 DC Injection Braking at Stop for V/f

**Note:** If b2-01 is set to a smaller value than parameter E1-09 (minimum frequency), then DC Injection Braking will begin as soon as the frequency falls to the value set to E1-09.

#### ■ b2-02: DC Injection Braking Current

Sets the DC Injection Braking current as a percentage of the drive rated current. The carrier frequency is automatically reduced to 1 kHz when this parameter is set to more than 50%.

No.	Name	Setting Range	Default
b2-02	DC Injection Braking Current	0 to 100%	50%

The level of DC Injection Braking current affects the strength of the magnetic field attempting to lock the motor shaft. Increasing the current level will increase the amount of heat generated by the motor windings. Do not set this parameter higher than the level necessary to hold the motor shaft.

## 5.2 b: Application

### ■ b2-03: DC Injection Braking Time at Start

Sets the time of DC Injection Braking at start. Used to stop a coasting motor before restarting it or to apply braking torque at start. Disabled when set to 0.00 s.

No.	Name	Setting Range	Default
b2-03	DC Injection Braking Time at Start	0.00 to 10.00 s	0.00 s

**Note:** Before starting an uncontrolled rotating motor (e.g., a fan motor driven by windmill effect), use DC Injection or Speed Search to stop the motor or detect motor speed before starting it. Otherwise, motor stalling and other faults can occur.

### ■ b2-04: DC Injection Braking Time at Stop

Sets the time of DC Injection Braking at stop. Used to completely stop a motor with high inertia load after ramp down. Increase the value if the motor still coasts by inertia after it should have stopped. Disabled when set to 0.00 s.

No.	Name	Setting Range	Default
b2-04	DC Injection Braking Time at Stop	0.00 to 10.00 s	0.00 s

## ◆ b3: Speed Search

The Speed Search function allows the drive to detect the speed of a rotating motor shaft that is driven by external forces and start the motor operation directly from the detected speed without first stopping the machine.

Example: When a momentary loss of power occurs, the drive output shuts off and the motor coasts. When power returns, the drive can find the speed of the coasting motor and restart it directly.

For induction motors, the drive offers two types of Speed Search that can be selected by parameter b3-24 (Speed Estimation and Current Detection). Both methods are explained below and followed by a description of all relevant parameters.

### ■ Current Detection Speed Search (b3-24 = 0)

Current Detection Speed Search detects the motor speed by looking at motor current in IM motors. When Speed Search is started it reduces the output frequency starting from either the maximum output frequency or the frequency reference while increasing the output voltage using the time set in parameter L2-04<sup><1></sup>. As long as the current is higher than the level set to b3-02, the output frequency is lowered using the time constant set to b3-03. If the current falls below b3-02, the drive assumes that the output frequency and motor speed are the same and accelerates or decelerates to the frequency reference.

<sup><1></sup> Details on this function can be found in the standard Z1000 Programming Manual (SIEPC71061645) at [www.yaskawa.com](http://www.yaskawa.com).

Be aware that sudden acceleration may occur when using this method of Speed Search with relatively light loads.

**Figure 5.7** illustrates Current Detection Speed Search operation after a momentary power loss (L2-01 must be set to 1 or 2):

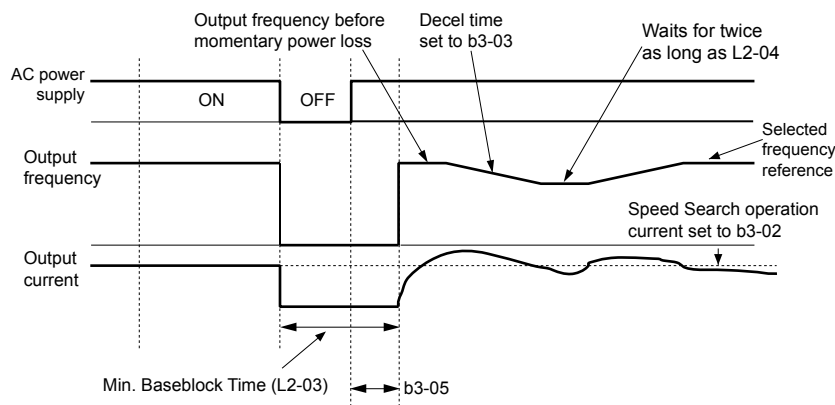

**Figure 5.7** Current Detection Speed Search after Power Loss

**Note:** After power is restored, the drive waits until the time set to b3-05 has passed before performing Speed Search. Thereby the Speed Search may start not at the end of L2-03 but even later.

When Speed Search is applied automatically with the Run command, the drive waits for the minimum baseblock time set to L2-03 before starting Speed Search. If L2-03 is lower than the time set to parameter b3-05, then b3-05 is used as the wait time.

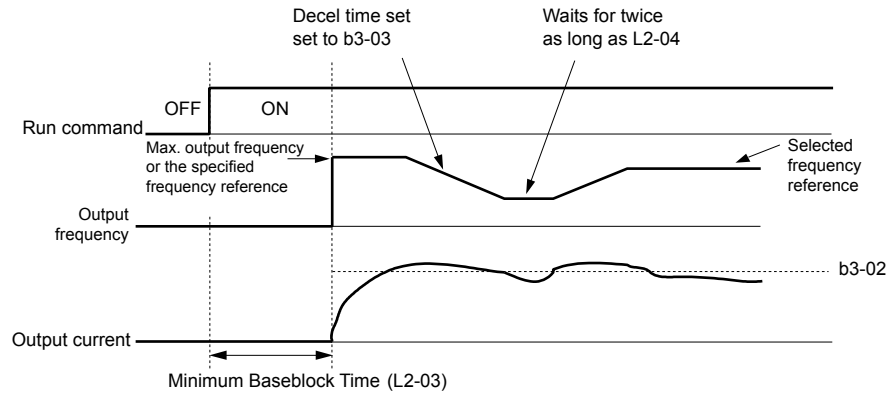

Figure 5.8 Current Detection Speed Search at Start or Speed Search Command by Digital Input

### Notes on Using Current Detection Type Speed Search

- Shorten the Speed Search deceleration time set to b3-03 if an oL1 fault occurs while performing Current Detection Speed Search.
- Increase the minimum baseblock time set to L2-03 if an overcurrent or overvoltage fault occurs when performing Speed Search after power is restored following a momentary power loss.

### ■ Speed Estimation Type Speed Search (b3-24 = 1)

This method can be used for a single induction motor connected to a drive. Do not use this method if the motor is one or more frame size smaller than the drive, at motor speeds above 200 Hz, or when using a single drive to operate more than one motor.

Speed Estimation is executed in the two steps described below:

#### Step 1: Back EMF Voltage Estimation

This method is used by Speed Search after baseblock (e.g., a power loss where the drive CPU continued to run and the Run command was kept active). Here, the drive estimates the motor speed by analyzing the back EMF voltage and outputs the estimated frequency and increases the voltage using the time constant set in parameter L2-04<sup><1></sup>. After that, the motor is accelerated or decelerated to the frequency reference starting from the detected speed. If there is not enough residual voltage in the motor windings to perform the calculations described above, the drive will automatically proceed to step 2.

<1> Details on this function can be found in the standard Z1000 Programming Manual (SIEPC71061645) at [www.yaskawa.com](http://www.yaskawa.com).

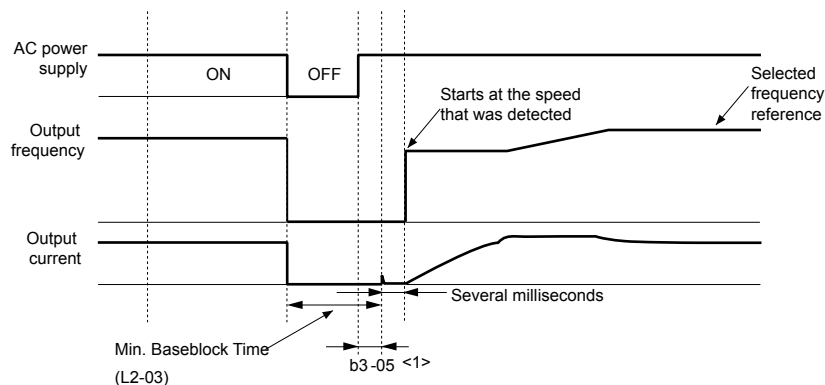

Figure 5.9 Speed Search after Baseblock

<1> After AC power is restored, the drive will wait for at least the time set to b3-05. If the power interruption is longer than the minimum baseblock time set to L2-03, the drive will wait until the time set to b3-05 has passed after power is restored before starting Speed Search.

#### Step 2: Current Injection

Current Injection is performed when there is insufficient residual voltage in the motor after extended power losses, when Speed Search is applied with the Run command (b3-01 = 1), or when an External search command is used.

## 5.2 b: Application

This feature injects the amount of DC current set to b3-06 to the motor and detects the speed by measuring the current feedback. The drive then outputs the detected frequency and increases the voltage using the time constant set to parameter L2-04<sup><1></sup> while looking at the motor current.

<1> Details on this function can be found in the standard Z1000 Programming Manual (SIEPC71061645) at [www.yaskawa.com](http://www.yaskawa.com).

The output frequency is reduced if the current is higher than the level in b3-02. When the current falls below b3-02, the motor speed is assumed to be found and the drive starts to accelerate or decelerate to the frequency reference.

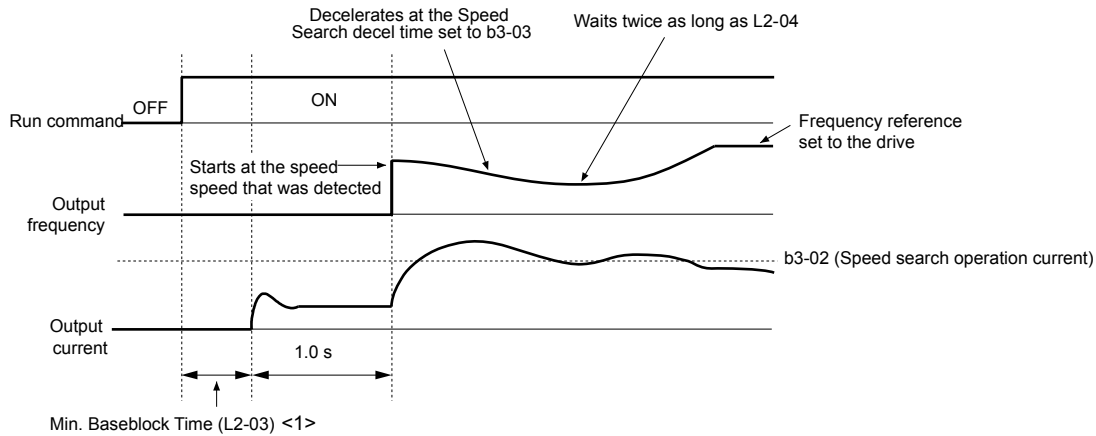

Figure 5.10 Speed Search at Start

<1> The wait time for Speed Search (b3-05) determines the lower limit.

### Notes on Using Speed Estimation Speed Search

- Perform Rotational Auto-Tuning for V/f Control (T1-01 = 3) prior to using Speed Estimation in V/f Control and perform Stationary Auto-Tuning for Line-to-Line Resistance (T1-01 = 2) again if there is a change in the cable length between the drive and motor.
- Use Current Detection to search for speeds beyond 200 Hz if the application is running multiple motors from the same drive or if the motor is considerably smaller than the capacity of the drive.
- Speed Estimation may have trouble finding the actual speed if the motor cable is very long. Use Current Detection in these instances.
- Use Current Detection instead of Speed Estimation when operating motors smaller than 1.5 kW because Speed Estimation might not be able to detect the speed or rotation of these smaller motors, in which case Speed Estimation would stop the motor.

### Speed Search Activation

Speed Search can be activated using any of the methods 1 through 5 described below. The Speed Search type must be selected in parameter b3-24 independent of the activation method.

**Method 1.** Automatically activate Speed Search with every Run command. External Speed Search commands are ignored.

**Method 2.** Activate Speed Search using the digital input terminals.

Use the input functions for H1-□□ in [Table 5.1](#).

Table 5.1 Speed Search Activation by Digital Inputs

Setting	Description	b3-24 = 0	b3-24 = 1
61	External Search Command 1	Closed: Activate Current Detection Speed Search from the maximum output frequency.	Activate Speed Estimation Speed Search
62	External Search Command 2	Closed: Activate Current Detection Speed Search from the frequency reference.	

To activate Speed Search by a digital input, the input must be set together with the Run command or the Run command must be entered after giving the Speed Search command.

**Method 3.** After automatic fault restart.

When the number of maximum fault restarts in parameter L5-01 is set higher than 0, the drive will automatically perform Speed Search as specified by b3-24 following a fault.

**Method 4.** After momentary power loss.

This mode requires that the Power Loss Ride-Thru function is enabled during CPU operation (L2-01 = 1 or 2). *Refer to L2-01: Momentary Power Loss Operation Selection on page 169.*

**Method 5.** After external baseblock is released.

The drive will resume the operation starting with Speed Search if the Run command is present and the output frequency is above the minimum frequency when the Baseblock command (H1-□□ = 8 or 9) is released.

### ■ b3-01: Speed Search Selection at Start

Determines if Speed Search is automatically performed when a Run command is issued.

No.	Parameter Name	Setting Range	Default
b3-01	Speed Search Selection at Start	0, 1	0

#### Setting 0: Disabled

This setting starts operating the drive at the minimum output frequency when the Run command is entered. If external Speed Search 1 or 2 is already enabled by a digital input, the drive will start operating with Speed Search.

#### Setting 1: Enabled

This setting performs Speed Search when the Run command is entered. The drive begins running the motor once Speed Search is complete.

### ■ b3-02: Speed Search Deactivation Current

Sets the operating current for Speed Search as a percentage of the drive rated current. Normally there is no need to change this setting. Lower this value if the drive has trouble restarting.

No.	Name	Setting Range	Default
b3-02	Speed Search Deactivation Current	0 to 200%	120%

### ■ b3-03: Speed Search Deceleration Time

Sets the output frequency reduction ramp used by the Current Injection Method of Speed Estimation (b3-24 = 1). The time entered into b3-03 will be the time to decelerate from maximum frequency (E1-04) to minimum frequency (E1-09).

No.	Name	Setting Range	Default
b3-03	Speed Search Deceleration Time	0.1 to 10.0 s	2.0 s

### ■ b3-04: V/f Gain during Speed Search (Speed Estimation Type)

During Speed Search, the output voltage calculated from the V/f pattern is multiplied with this value. Changing this value can help reduce the output current during Speed Search.

No.	Name	Setting Range	Default
b3-04	V/f Gain during Speed Search	10 to 100%	Determined by o2-04

### ■ b3-05: Speed Search Delay Time

In cases where an output contactor is used between the drive and the motor, the contactor must be closed before Speed Search can be performed. This parameter can be used to delay the Speed Search operation, giving the contactor enough time to close completely.

No.	Name	Setting Range	Default
b3-05	Speed Search Delay Time	0.0 to 100.0 s	0.2 s

### ■ b3-06: Output Current 1 during Speed Search (Speed Estimation Type)

Sets the current injected to the motor at the beginning of Speed Estimation Speed Search as a factor of the motor rated current set in E2-01. If the motor speed is relatively slow when the drive starts to perform Speed Search after a long period of baseblock, it may be helpful to increase the setting value. The output current during Speed Search is automatically limited by the drive rated current.

## 5.2 b: Application

No.	Name	Setting Range	Default
b3-06	Output Current 1 during Speed Search	0.0 to 2.0	Determined by o2-04

**Note:** Use Current Detection Speed Search if Speed Estimation is not working correctly even after adjusting b3-06.

### ■ b3-07: Output Current 2 during Speed Search (Speed Estimation Type)

Sets the amount of output current during Speed Estimation Speed Search as a coefficient for the no-load current (output current during Speed Search is automatically limited by the drive rated current).

Increase this setting value in increments of 0.1 if the drive fails to perform Speed Estimation.

No.	Name	Setting Range	Default
b3-07	Output Current 2 during Speed Search (Speed Estimation Type)	0.0 to 5.0	1.0

### ■ b3-08: Current Control Gain during Speed Search (Speed Estimation Type)

Sets the proportional gain for the current controller during Speed Search.

No.	Name	Setting Range	Default
b3-08	Current Control Gain during Speed Search (Speed Estimation Type)	0.00 to 6.00	Determined by o2-04

### ■ b3-09: Current Control Integral Time during Speed Search (Speed Estimation Type)

Sets the Integral Time for the current controller during Speed Search.

No.	Name	Setting Range	Default
b3-09	Current Control Integral Time during Speed Search (Speed Estimation Type)	0.0 to 1000.0 ms	2.0 ms

### ■ b3-10: Speed Search Detection Compensation Gain (Speed Estimation Type)

Sets the gain for the detected motor speed of the Speed Estimation Speed Search. Increase the setting only if an overvoltage fault occurs when the drive restarts the motor.

No.	Name	Setting Range	Default
b3-10	Speed Search Detection Compensation Gain	1.00 to 1.20	1.05

### ■ b3-11: Speed Search Method Switching Level (Speed Estimation Type)

Within the type of the speed measurement, the search method can be switched automatically by the amount of remaining voltage in the motor. This parameter sets the switching level. (208 Vac at 100% = 208 V, and 480 Vac at 100% = 480 V).

No.	Name	Setting Range	Default
b3-11	Speed Search Method Switching Level (Speed Estimation Type)	0.5 to 100.0%	5.0%

### ■ b3-12: Minimum Current Detection Level during Speed Search

Sets the minimum current detection level during Speed Search. Increase this setting value in increments of 0.1 if the drive fails to perform Speed Estimation.

No.	Name	Setting Range	Default
b3-12	Minimum Current Detection Level during Speed Search	2.0 to 10.0	Determined by o2-04

### ■ b3-14: Bi-Directional Speed Search Selection (Speed Estimation Type)

Sets how the drive determines the motor rotation direction when performing Speed Estimation Speed Search.

No.	Parameter Name	Setting Range	Default
b3-14	Bi-Directional Speed Search Selection	0, 1	1

**Setting 0: Disabled**

The drive uses the frequency reference to determine the direction of motor rotation to restart the motor.

**Setting 1: Enabled**

The drive detects the motor rotation direction to restart the motor.

**■ b3-17: Speed Search Restart Current Level (Speed Estimation Type)**

Sets the current level at which Speed Estimation is restarted as a percentage of drive rated current to avoid overcurrent and overvoltage problems since a large current can flow into the drive if the difference between the estimated frequency and the actual motor speed is too big when performing Speed Estimation.

No.	Name	Setting Range	Default
b3-17	Speed Search Restart Current Level	0 to 200%	110%

**■ b3-18: Speed Search Restart Detection Time (Speed Estimation Type)**

Sets the time for which the current must be above the level set in b3-17 before restarting Speed Search.

No.	Name	Setting Range	Default
b3-18	Speed Search Restart Detection Time	0.00 to 1.00 s	0.10 s

**■ b3-19: Number of Speed Search Restarts (Speed Estimation Type)**

Sets the number of times the drive should attempt to find the speed and restart the motor. If the number of restart attempts exceeds the value set to b3-19, the SEr fault will occur and the drive will stop.

No.	Name	Setting Range	Default
b3-19	Number of Speed Search Restarts	0 to 10	3

**■ b3-24: Speed Search Method Selection**

Sets the Speed Search method.

No.	Parameter Name	Setting Range	Default
b3-24	Speed Search Method Selection	0, 1	0

**Setting 0: Current Detection****Setting 1: Speed Estimation**

Note: Refer to *Current Detection Speed Search (b3-24 = 0)* on page 122 and *Refer to Speed Estimation Type Speed Search (b3-24 = 1)* on page 123 for explanations of the Speed Search methods.

**■ b3-25: Speed Search Wait Time**

Sets the wait time between Speed Search restarts. Increase the wait time if problems occur with overcurrent, overvoltage, or if the SEr fault occurs.

No.	Name	Setting Range	Default
b3-25	Speed Search Wait Time	0.0 to 30.0 s	0.5 s

**■ b3-27: Start Speed Search Select**

Selects a condition to activate Speed Search Selection at Start (b3-01) or External Speed Search Command 1 or 2 from the multi-function input.

No.	Name	Setting Range	Default
b3-27	Start Speed Search Select	0, 1	0

## 5.2 b: Application

**Setting 0: Triggered when a Run Command Is Issued (Normal)**

**Setting 1: Triggered when an External Baseblock Is Released**

### ◆ b5: PI Control

The drive has a built-in Proportional + Integral (PI) controller that uses the difference between the target value and the feedback value to adjust the drive output frequency to minimize deviation and provide accurate closed loop control of system variables such as pressure or temperature.

#### ■ P Control

The output of P control is the product of the deviation and the P gain so that it follows the deviation directly and linearly. With P control, only an offset between the target and feedback remains.

#### ■ I Control

The output of I control is the integral of the deviation. It minimizes the offset between target and feedback value that typically remains when pure P control is used. The integral time (I time) constant determines how fast the offset is eliminated.

#### ■ PI Operation

To better demonstrate PI functionality, the diagram below illustrates how the PI output changes when the PI input (deviation) jumps from 0 to a constant level.

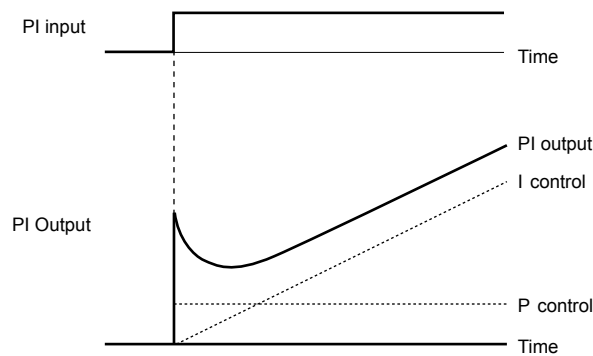

Figure 5.11 PI Operation

#### ■ Using PI Control

Applications for PI control are listed in the following table.

Application	Description	Sensors Used
Speed Control	Machinery speed is fed back and adjusted to meet the target value. Synchronous control is performed using speed data from other machinery as the target value	Tachometer
Pressure	Maintains constant pressure using pressure feedback.	Pressure sensor
Fluid Control	Keeps flow at a constant level by feeding back flow data.	Flow rate sensor
Temperature Control	Maintains a constant temperature by controlling a fan with a thermostat.	Thermocoupler, Thermistor

#### ■ PI Setpoint Input Methods

The PI setpoint input depends on the PI function setting in parameter b5-01.

If parameter b5-01 is set to 1 or 2, the frequency reference in b1-01 or one of the inputs listed in [Table 5.2](#) becomes the PI setpoint.

If b5-01 is set to 3 or 4, then the PI setpoint can be input from one of the sources listed in [Table 5.2](#).

Table 5.2 PI Setpoint Sources

PI Setpoint Source	Settings
Analog Input A1	Set H3-02 = C
Analog Input A2	Set H3-10 = C
MEMOBUS/Modbus Register 0006 H	Set bit 1 in register 000F H to 1 and input the setpoint to register 0006 H



PI Setpoint Source	Settings
Parameter b5-19	Set parameter b5-18 = 1 and input the PI setpoint to b5-19

**Note:** A duplicate allocation of the PI setpoint input will cause an oPE alarm.

## ■ PI Feedback Input Methods

Input one feedback signal for normal PI control or input two feedback signals for controlling a differential process value.

### Normal PI Feedback

Input the PI feedback signal from one of the sources listed below:

**Table 5.3 PI Feedback Sources**

PI Feedback Source	Settings
Analog Input A1	Set H3-02 = B
Analog Input A2	Set H3-10 = B

**Note:** A duplicate allocation of the PI feedback input will cause an oPE alarm.

### Differential Feedback

The second PI feedback signal for differential feedback can come from the sources listed below. The differential feedback function is automatically enabled when a differential feedback input is assigned.

**Table 5.4 PI Differential Feedback Sources**

PI Differential Feedback Source	Settings
Analog Input A1	Set H3-02 = 16
Analog Input A2	Set H3-10 = 16

**Note:** A duplicate allocation of the PI differential feedback input will cause an oPE alarm.

PI Block Diagram

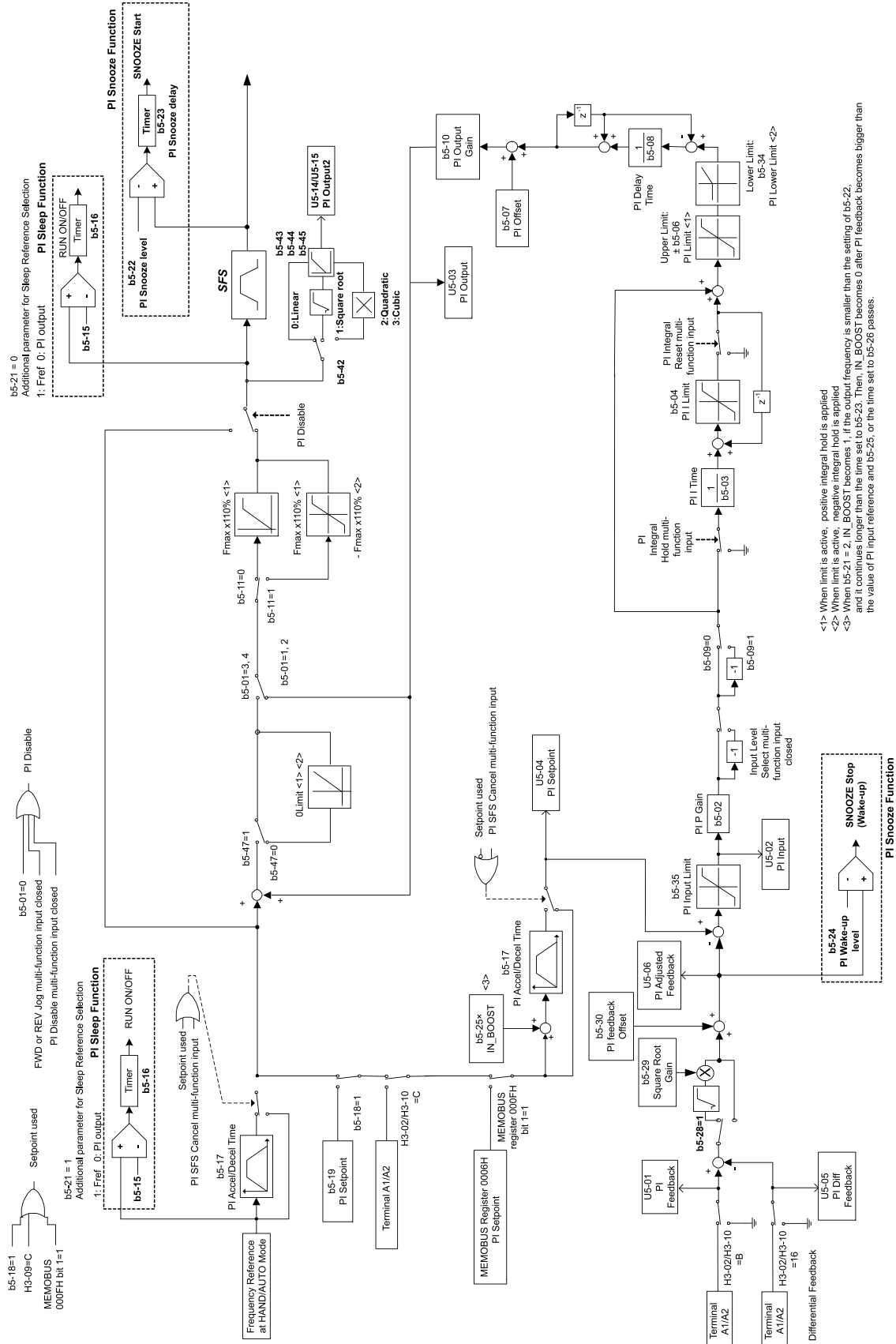

<1> When limit is active, positive integral hold is applied  
 <2> When limit is active, negative integral hold is applied  
 <3> When b5-21 = 2, IN\_BOOST becomes 1. If the output frequency is smaller than the setting of b5-22, and it continues longer than the time set to b5-23, then, IN\_BOOST becomes 0 after PI feedback becomes bigger than the value of PI input reference and b5-25, or the time set to b5-26 passes.

Figure 5.12 PI Block Diagram

### ■ b5-01: PI Function Setting

Enables or disables the PI operation and selects the PI operation mode.

No.	Parameter Name	Setting Range	Default
b5-01	PI Function Setting	0, 1, 3	0

#### Setting 0: PI Disabled

#### Setting 1: Output Frequency = PI Output 1

The PI controller is enabled and the PI output builds the frequency reference.

#### Setting 3: Output Frequency = Frequency Reference + PI Output 1

The PI controller is enabled and the PI output is added to the frequency reference.

### ■ b5-02: Proportional Gain Setting (P)

Sets the P gain applied to the PI input. Larger values will tend to reduce the error but may cause oscillations if set too high, while lower values may allow too much offset between the setpoint and feedback.

No.	Name	Setting Range	Default
b5-02	Proportional Gain Setting (P)	0.00 to 25.00	2.00

### ■ b5-03: Integral Time Setting (I)

Sets the time constant used to calculate the integral of the PI input. The shorter the integral time set to b5-03, the faster the offset will be eliminated. If the integral time is set too short, however, overshoot or oscillation may occur. To turn off the integral time, set b5-03 to 0.00.

No.	Name	Setting Range	Default
b5-03	Integral Time Setting (I)	0.0 to 360.0 s	0.5 s

### ■ b5-04: Integral Limit Setting

Sets the maximum output possible from the integral block as a percentage of the maximum frequency (E1-04).

No.	Name	Setting Range	Default
b5-04	Integral Limit Setting	0.0 to 100.0%	100.0%

**Note:** On some applications, especially those with rapidly varying loads, the output of the PI function may show a fair amount of oscillation. Program b5-04 to apply a limit to the integral output and suppress this oscillation.

### ■ b5-06: PI Output Limit

Sets the maximum output possible from the entire PI controller as a percentage of the maximum frequency (E1-04).

No.	Name	Setting Range	Default
b5-06	PI Output Limit	0.0 to 100.0%	100.0%

### ■ b5-07: PI Offset Adjustment

Sets the offset added to the PI controller output as a percentage of the maximum frequency (E1-04).

No.	Name	Setting Range	Default
b5-07	PI Offset Adjustment	-100.0 to 100.0%	0.0%

### ■ b5-08: PI Primary Delay Time Constant

Sets the time constant for the filter applied to the output of the PI controller. Normally, change is not required.

No.	Name	Setting Range	Default
b5-08	PI Primary Delay Time Constant	0.00 to 10.00 s	0.00 s

**Note:** Useful when there is a fair amount of oscillation or when rigidity is low. Set to a value larger than the cycle of the resonant frequency. Increasing this time constant may reduce the responsiveness of the drive.

## 5.2 b: Application

### ■ b5-09: PI Output Level Selection

Reverses the sign of the PI controller output signal. Normally a positive PI input (feedback smaller than setpoint) leads to positive PI output.

No.	Parameter Name	Setting Range	Default
b5-09	PI Output Level Selection	0, 1	0

#### Setting 0: Normal Output

A positive PI input causes an increase in the PI output (direct acting).

#### Setting 1: Reverse Output

A positive PI input causes a decrease in the PI output (reverse acting).

### ■ b5-10: PI Output Gain Setting

Applies a gain to the PI output and can be helpful when the PI function is used to trim the frequency reference (b5-01 = 3 or 4).

No.	Name	Setting Range	Default
b5-10	PI Output Gain Setting	0.00 to 25.00	1.00

### ■ b5-11: PI Output Reverse Selection

Determines whether a negative PI output reverses the direction of drive operation. This parameter has no effect when the PI function trims the frequency reference (b5-01 = 3) and the PI output will not be limited (same as b5-11 = 1).

No.	Parameter Name	Setting Range	Default
b5-11	PI Output Reverse Selection	0, 1	0

#### Setting 0: Reverse Disabled

Negative PI output will be limited to 0 and the drive output will be stopped.

#### Setting 1: Reverse Enabled

Negative PI output will cause the drive to run in the opposite direction.

### ■ PI Feedback Loss Detection

The PI feedback loss detection function detects broken sensors or broken sensor wiring. It should be used when PI control is enabled to prevent critical machine conditions (e.g., acceleration to max. frequency) caused by a feedback loss.

Feedback loss can be detected in two ways:

#### • Feedback Low Detection

Detected when the feedback falls below a certain level for longer than the specified time. This function is set up using parameters b5-12 to b5-14.

#### • Feedback High Detection

Detected when the feedback rises above a certain level for longer than the specified time. This function is set up using parameters b5-12, b5-36, and b5-37.

The following figure illustrates the working principle of feedback loss detection when the feedback signal is too low. Feedback high detection works in the same way.

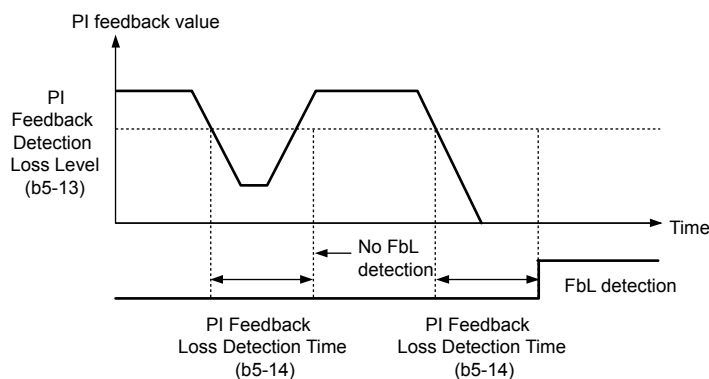

Figure 5.13 PI Feedback Loss Detection

## ■ b5-12: PI Feedback Loss Detection Selection

Enables and disables the feedback loss detection and sets the operation when a feedback loss is detected.

No.	Parameter Name	Setting Range	Default
b5-12	PI Feedback Loss Detection Selection	0 to 5	0

### Setting 0: Digital Output Only

A digital output set for “PI feedback low” ( $H2-\square\square = 3E^{</>}$ ) will be triggered if the PI feedback value is below the detection level set to b5-13 for the time set to b5-14 or longer. A digital output set for “PI feedback high” ( $H2-\square\square = 3F^{</>}$ ) will be triggered if the PI feedback value is beyond the detection level set to b5-36 for longer than the time set to b5-37. Neither a fault nor an alarm is displayed on the HOA keypad and the drive will continue operation. The output resets when the feedback value leaves the loss detection range.

### Setting 1: Feedback Loss Alarm

If the PI feedback value falls below the level set to b5-13 for longer than the time set to b5-14, a “FbL - Feedback Low” alarm will be displayed and a digital output set for “PI feedback low” ( $H2-\square\square = 3E^{</>}$ ) will be triggered. If the PI feedback value exceeds the level set to b5-36 for longer than the time set to b5-37, a “FbH - Feedback High” alarm will be displayed and a digital output set for “PI feedback high” ( $H2-\square\square = 3F^{</>}$ ) will be triggered. Both events trigger an alarm output ( $H1-\square\square = 10$ ). The drive will continue operation. The alarm and outputs reset when the feedback value leaves the loss detection range.

### Setting 2: Feedback Loss Fault

If the PI feedback value falls below the level set to b5-13 for longer than the time set to b5-14, a “FbL - Feedback Low” fault will be displayed. If the PI feedback value exceeds the level set to b5-36 for longer than the time set to b5-37, a “FbH - Feedback High” fault will be displayed. Both events trigger a fault output ( $H1-\square\square = E^{</>}$ ) and cause the drive to stop the motor. Detection remains active when PI is disabled by digital input ( $H1-\square\square = 19$ ).

### Setting 3: Digital Output Always

Same as Setting 0, except that PI must be active and the drive must be running.

### Setting 4: Alarm Always

Same as Setting 1, except that PI must be active and the drive must be running.

### Setting 5: Fault Always

Same as Setting 2, except that PI must be active and the drive must be running.

<1> Details on this function can be found in the standard Z1000 Programming Manual (SIEPC71061645) at [www.yaskawa.com](http://www.yaskawa.com).

## ■ b5-13: PI Feedback Low Detection Level

Sets the feedback level used for PI feedback low detection. The PI feedback must fall below this level for longer than the time set to b5-14 before feedback loss is detected.

No.	Name	Setting Range	Default
b5-13	PI Feedback Low Detection Level	0 to 100%	0%

## 5.2 b: Application

### ■ b5-14: PI Feedback Low Detection Time

Sets the time that the PI feedback has to fall below b5-13 before feedback loss is detected.

No.	Name	Setting Range	Default
b5-14	PI Feedback Low Detection Time	0.0 to 25.5 s	1.0 s

### ■ b5-36: PI Feedback High Detection Level

Sets the feedback level used for PI feedback high detection. The PI feedback must exceed this level for longer than the time set to b5-37 before feedback loss is detected.

No.	Name	Setting Range	Default
b5-36	PI Feedback High Detection Level	0 to 100%	100%

### ■ b5-37: PI Feedback High Detection Time

Sets the time that the PI feedback must exceed the value set to b5-36 before feedback loss is detected.

No.	Name	Setting Range	Default
b5-37	PI Feedback High Detection Time	0.0 to 25.5 s	1.0 s

<1> Details on this function can be found in the standard Z1000 Programming Manual (SIEPC71061645) at [www.yaskawa.com](http://www.yaskawa.com).

### ■ PI Sleep/Snooze

The PI Sleep/Snooze function stops the drive when the PI output or the frequency reference falls below the PID Sleep/Snooze operation level for a certain time. The drive will resume operating when the PI output or frequency reference rise above the PI Sleep/Snooze operation level for the specified time. An example of PI Sleep/Snooze operation appears in the figure below.

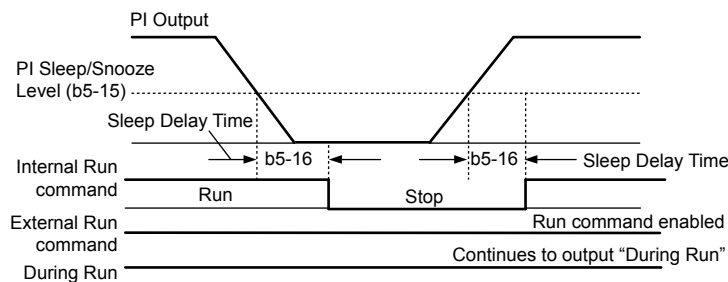

Figure 5.14 PI Sleep/Snooze Operation

#### Notes on Using the PI Sleep/Snooze Function

- The PI Sleep/Snooze function is active even when PI control is disabled.
- The PI Sleep/Snooze function stops the motor according to the stopping method set to b1-03.

The PI Snooze Function is a variation on the Sleep Function. Set b5-21 to 2 to select the PI Snooze function. After selecting the Snooze Function, the drive monitors the output frequency. If the output frequency drops below the PI Snooze Level b5-22 <1>, and stays below that level for at least the time set to b5-23 <1>, PI Snooze Delay Time, the drive output shuts off.

The Snooze Function differs from the Sleep Function in that the feedback must drop below the level set to b5-24 <1>, PI Snooze Deactivation Level, before normal drive output will begin again. Immediately prior to Snooze Function activation, the PI Setpoint can be temporarily increased to create an overshoot of the intended PI Setpoint. The temporary boost is determined by parameter b5-25 <1>, PI Boost Setting Level.

After reaching the temporary boost level (or exceeding the time set to b5-26, PI Maximum Boost Time), the drive output shuts off (snoozes) and the intended PI Setpoint returns. From this point on, the Snooze Function operates normally and the drive output returns when the feedback level drops below b5-24 <1>.

<1> Details on this function can be found in the standard Z1000 Programming Manual (SIEPC71061645) at [www.yaskawa.com](http://www.yaskawa.com).

The parameters necessary to control the PI Sleep/Snooze Function are explained below.

### ■ b5-15: PI Sleep Function Start Level

Sets the level that triggers PI Sleep/Snooze.

The drive goes into Sleep/Snooze mode if the PI output or frequency reference is smaller than b5-15 for longer than the time set to b5-16. The drive resumes operation when the PI output or frequency reference is above b5-15 for longer than the time set to b5-16.

No.	Name	Setting Range	Default
b5-15	PI Sleep Function Start Level	0.0 to 240.0 Hz	0.0 Hz

### ■ b5-16: PI Sleep Delay Time

Sets the delay time to activate or deactivate the PI Sleep/Snooze function.

No.	Name	Setting Range	Default
b5-16	PI Sleep Delay Time	0.0 to 25.5 s	0.0 s

### ■ b5-17: PI Accel/Decel Time

The PI acceleration/deceleration time is applied on the PI setpoint value.

When the setpoint changes quickly, the normal C1-□□ acceleration times reduce the responsiveness of the system as they are applied after the PI output. The PI accel/decel time helps avoid the hunting and overshoot and undershoot that can result from the reduced responsiveness.

The PI acceleration/deceleration time can be canceled using a digital input programmed for “PI SFS cancel” (H1-□□ = 34).

No.	Name	Setting Range	Default
b5-17	PI Accel/Decel Time	0.0 to 6000.0 s	0.0 s

### ■ b5-18: PI Setpoint Selection

Enables or disables parameter b5-19 for PI setpoint.

No.	Parameter Name	Setting Range	Default
b5-18	PI Setpoint Selection	0, 1	0

#### Setting 0: Disabled

Parameter b5-19 is not used as the PI setpoint.

#### Setting 1: Enabled

Parameter b5-19 is used as PI setpoint.

### ■ b5-19: PI Setpoint Value

Used as the PI setpoint if parameter b5-18 = 1.

No.	Name	Setting Range	Default
b5-19	PI Setpoint Value	0.00 to 600.00%	0.00%

**Note:** Unit and resolution for b5-19 are determined by b5-20 and b5-39.

The following conditions apply to drives with software PRG: 1014 and later. Parameter b5-19 is internally limited to b5-38. Changing b5-20, b5-38 and b5-39 will not automatically update the value of b5-19.

### ■ b5-20: PI Setpoint Scaling

Determines the units for the PI Setpoint Value (b5-19) and monitors U5-01 and U5-04.

No.	Parameter Name	Setting Range	Default
b5-20	PI Setpoint Scaling	0 to 3	1

#### Setting 0: Hz

The setpoint and PI monitors are displayed in Hz with a resolution of 0.01 Hz.

## 5.2 b: Application

### Setting 1: %

The setpoint and PI monitors are displayed as a percentage with a resolution of 0.01%.

### Setting 2: r/min

The setpoint and PI monitors are displayed in r/min with a resolution of 1 r/min.

### Setting 3: User Defined

Parameters b5-38 and b5-39 determine the units and resolution used to display the values the setpoint in b5-19, and PI monitors U5-01 and U5-04.

#### ■ b5-34: PI Output Lower Limit

Sets the minimum possible PI controller output as a percentage of the maximum output frequency (E1-04). The lower limit is disabled when set to 0.00%

No.	Name	Setting Range	Default
b5-34	PI Output Lower Limit	-100.0 to 100.0%	0.0%

#### ■ b5-35: PI Input Limit

Sets the maximum allowed PI input as a percentage of the maximum output frequency (E1-04). Parameter b5-35 acts as a bipolar limit.

No.	Name	Setting Range	Default
b5-35	PI Input Limit	0 to 1000.0%	1000.0%

#### ■ b5-38, b5-39: PI Setpoint User Display, PI Setpoint Display Digits

When parameter b5-20 is set to 3, parameters b5-38 and b5-39 set a user-defined display for the PI setpoint (b5-19) and PI feedback monitors (U5-01, U5-04).

Parameter b5-38 determines the display value when the maximum frequency is output and parameter b5-39 determines the number of digits. The setting value is equal to the number of decimal places.

No.	Name	Setting Range	Default
b5-38	PI Setpoint User Display	1 to 60000	Determined by b5-20
b5-39	PI Setpoint Display Digits	0 to 3	Determined by b5-20

#### ■ b5-40: Frequency Reference Monitor Content During PI

Sets the content of the frequency reference monitor display (U1-01) when PI control is active.

No.	Name	Setting Range	Default
b5-40	Frequency Reference Monitor Content During PI	0, 1	0

### Setting 0: Frequency Reference after PI

Monitor U1-01 displays the frequency reference increased or reduced for the PI output.

### Setting 1: Frequency Reference before PI

Monitor U1-01 displays the frequency reference value.

#### ■ b5-46: PI Setpoint Monitor Unit Selection

Sets the HOA keypad display units in U5-01 and U5-04 when b5-20 is set to 3.

No.	Name	Setting Range	Default
b5-46	PI Setpoint Monitor Unit Selection	0 to 14	0



**Setting 0: “WC (Inch of Water)**

**Setting 1: PSI (Pounds per Square Inch)**

**Setting 2: GPM (Gallons per Minute)**

**Setting 3: F (Degrees Fahrenheit)**

**Setting 4: CFM (Cubic Feet per Minute)**

**Setting 5: CMH (Cubic Meters per Hour)**

**Setting 6: LPH (Liters per Hour)**

**Setting 7: LPS (Liters per Second)**

**Setting 8: Bar (Bar)**

**Setting 9: Pa (Pascal)**

**Setting 10: C (Degrees Celsius)**

**Setting 11: Mtr (Meters)**

**Setting 12: Ft (Feet)**

**Setting 13: LPM (Liters per Minute)**

**Setting 14: CMM (Cubic Meters per Minute)**

### ■ b5-47: Reverse Operation Selection 2 by PI Output

Determines whether a negative PI output reverses the direction of drive operation. When the PI function is used to trim the frequency reference (b5-01 = 3), this parameter has no effect and the PI output will not be limited (same as b5-11 = 1).

No.	Name	Setting Range	Default
b5-47	Reverse Operation Selection 2 by PI Output	0, 1	1

#### Setting 0: 0 Limit (Reverse Disabled)

Negative PI output will be limited to zero and the drive output will be stopped.

#### Setting 1: Reverse Enabled

Negative PI output will cause the drive to run in the opposite direction.

### ■ Fine-Tuning PI

Follow the directions below to fine tune PI control parameters:

**Table 5.5 PI Fine Tuning**

Goal	Tuning Procedure	Result
Suppress overshoot	Increase the integral time (b5-03)	<p>The graph plots Response on the vertical axis and Time on the horizontal axis. A horizontal dashed line represents the target response level. Two curves start from the origin: the upper curve, labeled 'Before adjustment', rises to a peak above the target line (overshoot) before settling; the lower curve, labeled 'After adjustment', rises more gradually and settles at the target line with less overshoot.</p>
Achieve stability quickly while allowing some overshoot	Decrease the integral time (b5-03)	<p>The graph plots Response on the vertical axis and Time on the horizontal axis. A horizontal dashed line represents the target response level. Two curves start from the origin: the upper curve, labeled 'After adjustment', rises more steeply to a peak above the target line (overshoot) and then settles quickly; the lower curve, labeled 'Before adjustment', rises more gradually and takes longer to settle at the target line.</p>

## 5.2 b: Application

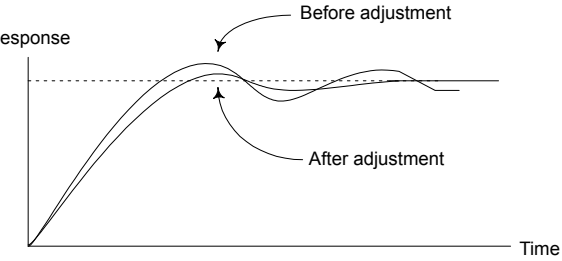
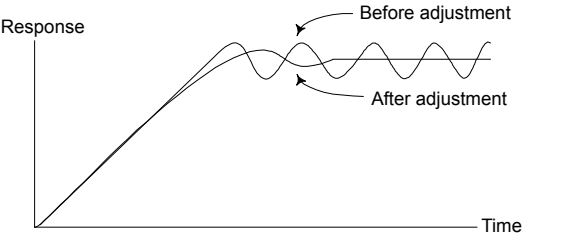
Goal	Tuning Procedure	Result
Suppress long cycle oscillations (longer than the integral time setting)	Increase the integral time (b5-03)	 <p>The graph plots Response on the vertical axis and Time on the horizontal axis. A horizontal dashed line represents the target response level. Two curves are shown: 'Before adjustment' and 'After adjustment'. Both curves rise from the origin and reach the target level. The 'Before adjustment' curve exhibits a large overshoot followed by a long, low-frequency oscillation that takes a significant amount of time to settle. The 'After adjustment' curve reaches the target level with a smaller overshoot and settles much more quickly, with its oscillations being significantly shorter in period and amplitude.</p>
Suppress short cycle oscillations	If oscillations are a problem, reduce the proportional gain (b5-02) or increase the PI primary delay time (b5-08)	 <p>The graph plots Response on the vertical axis and Time on the horizontal axis. Two curves are shown: 'Before adjustment' and 'After adjustment'. Both curves rise from the origin and reach a target level. The 'Before adjustment' curve shows a sharp overshoot followed by high-frequency, high-amplitude oscillations that persist for a long duration. The 'After adjustment' curve reaches the target level with a similar overshoot but exhibits much lower frequency and amplitude in its subsequent oscillations, indicating improved stability.</p>

## 5.4 C: Tuning

C parameters set the characteristics for acceleration, deceleration, and S-curves. Other parameters in the C group cover settings for slip compensation, torque compensation, and carrier frequency.

### ◆ C1: Acceleration and Deceleration Times

#### ■ C1-01 and C1-02: Accel, Decel Time 1

Four different sets of acceleration and deceleration times can be set in the drive by digital inputs, motor selection, or switched automatically.

Acceleration time parameters always set the time to accelerate from 0 Hz to the maximum output frequency (E1-04). Deceleration time parameters always set the time to decelerate from maximum output frequency to 0 Hz. C1-01 and C1-02 are the default active accel/decel settings.

No.	Parameter Name	Setting Range	Default
C1-01	Acceleration Time 1	0.1 to 6000.0 s	30.0 s
C1-02	Deceleration Time 1		

#### ■ C1-09: Fast Stop Time

Sets a special deceleration used when a select group of faults occur or when closing a digital input configured as H1-□□ = 15 (N.O. input) or 17 (N.C. input). A momentary closure of the digital input will trigger the Fast Stop operation; it does not have to be closed continuously.

The drive cannot be restarted after initiating a Fast Stop operation until after completing deceleration, clearing the Fast Stop input, and cycling the Run command.

A digital output programmed for “During Fast Stop” (H2-□□ = 4C<sup>l</sup>) will be closed as long as Fast Stop is active.

<sup>l</sup> Details on this function can be found in the standard Z1000 Programming Manual (SIEPC71061645) at [www.yaskawa.com](http://www.yaskawa.com).

No.	Parameter Name	Setting Range	Default
C1-09	Fast Stop Time	0.1 to 6000.0 s	10.0 s

**NOTICE:** Rapid deceleration can trigger an overvoltage fault. The drive output shuts off when faulted and the motor coasts. Set an appropriate Fast Stop time to C1-09 to avoid this uncontrolled motor state and to ensure that the motor stops quickly and safely.

### ◆ C2: S-Curve Characteristics

Use S-curve characteristics to smooth acceleration and deceleration and minimize abrupt shock to the load. Set S-curve characteristic time during acceleration/deceleration at start and acceleration/deceleration at stop.

#### ■ C2-01 and C2-02: S-Curve Characteristics

C2-01 and C2-02 set separate S-curves for each section of the acceleration or deceleration.

No.	Parameter Name	Setting Range	Default
C2-01	S-Curve Characteristic at Accel Start	0.00 to 10.00 s	0.20 s
C2-02	S-Curve Characteristic at Accel End		0.20 s

*Figure 5.15* illustrates S-curve application.

## 5.4 C: Tuning

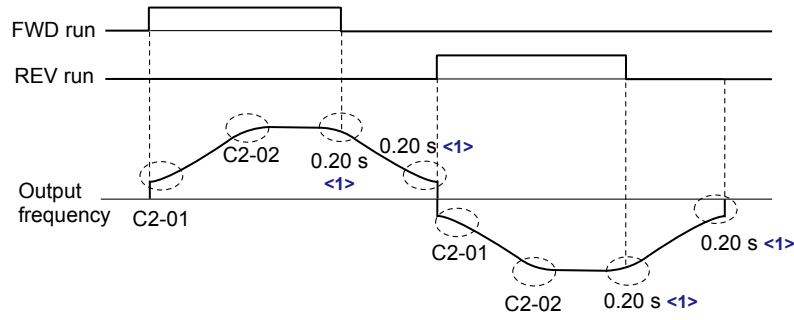

<1> S-Curve characteristic at Decel Start/End is fixed to 0.20 s.

**Figure 5.15 S-Curve Timing Diagram - FWD/REV Operation**

Setting the S-curve will increase the acceleration and deceleration times.

Actual accel time = accel time setting + (C2-01 + C2-02) / 2

### ◆ C4: Torque Compensation

The torque compensation function compensates for insufficient torque production at start-up or when a load is applied.

**Note:** Set the motor parameters and V/f pattern properly before setting torque compensation parameters.

#### ■ C4-01: Torque Compensation Gain

Sets the gain for the torque compensation function.

No.	Parameter Name	Setting Range	Default
C4-01	Torque Compensation Gain	0.00 to 2.50	1.00

#### Torque Compensation:

The drive calculates the motor primary voltage loss using the output current and the termination resistor value (E2-05) and adjusts the output voltage to compensate insufficient torque at start or when load is applied. The effects of this voltage compensation can be increased or decreased using parameter C4-01.

#### Adjustment

Although this parameter rarely needs to be changed, it may be necessary to adjust the torque compensation gain in small steps of 0.05 in the following situations:

- Increase this setting when using a long motor cable.
- Decrease this setting when motor oscillation occurs.

Adjust C4-01 so the output current does not exceed the drive rated current.

### ◆ C6: Carrier Frequency

#### ■ C6-02: Carrier Frequency Selection

Sets the switching frequency of the drive output transistors. Changes to the switching frequency lower audible noise and reduce leakage current.

**Note:** Increasing the carrier frequency above the default value automatically lowers the drive current rating.

No.	Parameter Name	Setting Range	Default
C6-02	Carrier Frequency Selection	1 to A	Determined by o2-04

#### Settings:

C6-02	Carrier Frequency	C6-02	Carrier Frequency
1	2.0 kHz	6	15.0 kHz
2	5.0 kHz	7	Swing PWM 1
3	8.0 kHz	8	Swing PWM 2
4	10.0 kHz	9	Swing PWM 3
5	12.5 kHz	A	Swing PWM 4

**Note:** Swing PWM uses a carrier frequency of 2.0 kHz as a base, then applies a special PWM pattern to reduce the audible noise.

## Guidelines for Carrier Frequency Parameter Setup

Symptom	Remedy
Speed and torque are unstable at low speeds	Lower the carrier frequency.
Noise from the drive affects peripheral devices	
Excessive leakage current from the drive	
Wiring between the drive and motor is too long <sup>&lt;1&gt;</sup>	
Audible motor noise is too loud	Increase the carrier frequency or use Swing PWM.

<sup><1></sup> The carrier frequency may need to be lowered if the motor cable is too long. Refer to the following table.

Wiring Distance	Up to 50 m	Up to 100 m	Greater than 100 m
Recommended setting value for C6-02	1 to A (up to 15 kHz)	1 to 2 (up to 5 kHz), 7 (Swing PWM)	1 (up to 2 kHz), 7 (Swing PWM)

### ■ C6-05: Carrier Frequency Proportional Gain

Sets a user-defined or a variable carrier frequency. Set C6-02 to F to set the upper and lower limits and the carrier frequency proportional gain.

No.	Parameter Name	Setting Range	Default
C6-05	Carrier Frequency Proportional Gain (V/f Control only)	0 to 99	Determined by C6-02

#### Setting a Fixed User-Defined Carrier Frequency

A carrier frequency between the fixed selectable values can be entered in parameter C6-03<sup><1></sup> when C6-02 is set to F. In V/f Control, adjust parameter C6-04<sup><1></sup> to the same value as C6-03<sup><1></sup>.

#### Setting a Variable Carrier Frequency (V/f Control)

In V/f Control, the carrier frequency can be set up to change linearly with the output frequency by setting the upper and lower limits for the carrier frequency and the carrier frequency proportional gain (C6-03<sup><1></sup>, C6-04<sup><1></sup>, C6-05) as shown in [Figure 5.16](#).

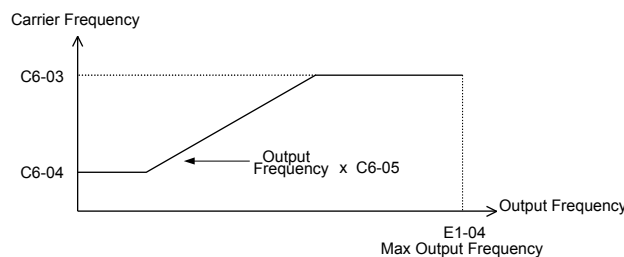

**Figure 5.16 Carrier Frequency Changes Relative to Output Frequency**

**Note:** When C6-05 is set lower than 7, C6-04<sup><1></sup> is disabled and the carrier frequency will be fixed to the value set in C6-03<sup><1></sup>.

<sup><1></sup> Details on this function can be found in the standard Z1000 Programming Manual (SIEPC71061645) at [www.yaskawa.com](http://www.yaskawa.com).

## 5.5 d: Reference Settings

The figure below gives an overview of the reference input, selections, and priorities.

### ◆ d1: Frequency Reference

#### ■ d1-01 to d1-04: Frequency References 1 to 4

The drive lets the user switch between up to 5 preset frequency references during run (including the Jog reference) through the digital input terminals. The drive uses the acceleration and deceleration times that have been selected when switching between each frequency reference.

The Jog frequency overrides all other frequency references and must be selected by a separate digital input.

The multi-speed references 1 and 2 can be provided by analog inputs.

No.	Parameter Name	Setting Range	Default
d1-01 to d1-04	Frequency Reference 1 to 4	0.00 to 240.00 Hz <1> <2>	0.00 Hz <2>

<1> The upper limit is determined by the maximum output frequency (E1-04) and upper limit for the frequency reference (d2-01). Parameter d2-01 is not accessible.

<2> Setting units are determined by parameter o1-03. The default is “Hz” (o1-03 = 0).

#### Multi-Step Speed Selection

To use several speed references for a multi-step speed sequence, set the Z2-□□ (DI-□□ Select) parameters to 5 (S5) and 6 (S6). To assign the Jog reference to a digital input, set Z2-□□ (DI-□□ Select) to 7 (S7).

Notes on using analog inputs as Multi-Speed 1 and 2:

- The first frequency reference (Multi-Speed 1) comes from the source specified in Z1-07. When using an analog input terminal to supply the frequency reference, assign the frequency reference source to the control terminals (Z1-07 = 1).
- When an analog input is set to “Auxiliary frequency 1” (H3-02 or H3-10 = 2), the value set to this input will be used as the Multi-Step Speed 2 instead of the value set to parameter d1-02. If no analog inputs are set for “Auxiliary frequency 1”, then d1-02 becomes the reference for Multi-Step Speed 2.

Select the different speed references as shown in [Table 5.6](#). [Figure 5.17](#) illustrates the multi-step speed selection.

**Table 5.6 Multi-Step Speed Reference and Terminal Switch Combinations**

Reference	Multi-Step Speed Z2-□□ = 5	Multi-Step Speed 2 Z2-□□ = 6	Jog Reference Z2-□□ = 7
Frequency Reference 1 (set in b1-01)	OFF	OFF	OFF
Frequency Reference 2 (d1-02 or input terminal A1, A2)	ON	OFF	OFF
Frequency Reference 3 (d1-03 or input terminal A1, A2)	OFF	ON	OFF
Frequency Reference 4 (d1-04)	ON	ON	OFF

<1> The Jog frequency overrides all other frequency references.

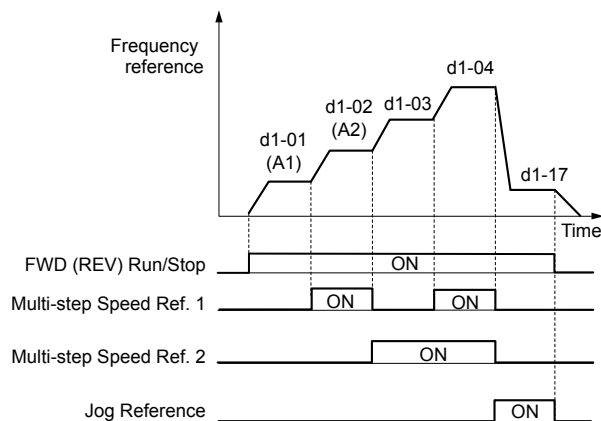

**Figure 5.17 Preset Reference Timing Diagram**

## ◆ d2: Frequency Upper/Lower Limits

Upper and lower frequency limits prevent motor speed from going above or below levels that may cause resonance or equipment damage.

### ■ d2-01: Frequency Reference Upper Limit

Sets the maximum frequency reference as a percentage of the maximum output frequency. This limit applies to all frequency references.

Even if the frequency reference is set to a higher value, the drive internal frequency reference will not exceed this value.

No.	Parameter Name	Setting Range	Default
d2-01	Frequency Reference Upper Limit	0.0 to 110.0%	100.0%

**Note:** This value is overwritten by the energy savings function. When energy savings is enabled, (Z1-16 = 1 or 2), this value will be set to 110%. When energy savings is not enabled (Z1-16 = 0), the bypass controller will not change this value.

### ■ d2-02: Frequency Reference Lower Limit

Sets the minimum frequency reference as a percentage of the maximum output frequency. This limit applies to all frequency references.

If a lower reference than this value is entered, the drive will run at the limit set to d2-02. If the drive is started with a lower reference than d2-02, it will accelerate up to d2-02.

No.	Parameter Name	Setting Range	Default
d2-02	Frequency Reference Lower Limit	0.0 to 110.0%	0.0%

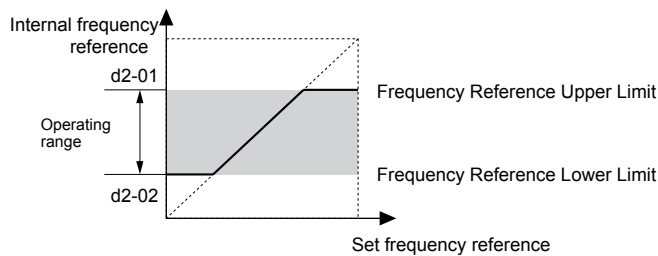

Figure 5.18 Frequency Reference: Upper and Lower Limits

### ■ d2-03: Master Speed Reference Lower Limit

Sets a lower limit as a percentage of the maximum output frequency that will only affect a frequency reference entered from the analog input terminals (A1 or A2) as the master speed reference. This is unlike parameter d2-02, which affects all frequency references regardless of their source.

**Note:** When lower limits are set to both parameters d2-02 and d2-03, the drive uses the greater of those two values as the lower limit.

No.	Parameter Name	Setting Range	Default
d2-03	Master Speed Reference Lower Limit	0.0 to 110.0%	0.0%

### ◆ d3: Jump Frequency

#### ■ d3-01 to d3-04: Jump Frequencies 1, 2, 3 and Jump Frequency Width

The Jump frequencies are frequency ranges at which the drive will not operate. The drive can be programmed with three separate Jump frequencies to avoid operating at speeds that cause resonance in driven machinery. If the speed reference falls within a Jump frequency dead band, the drive will clamp the frequency reference just below the dead band and only accelerate past it when the frequency reference rises above the upper end of the dead band.

Setting parameters d3-01 through d3-03 to 0.0 Hz disables the Jump frequency function.

No.	Parameter Name	Setting Range	Default
d3-01	Jump Frequency 1	0.0 to 240.0 Hz	0.0 Hz
d3-02	Jump Frequency 2	0.0 to 240.0 Hz	0.0 Hz
d3-03	Jump Frequency 3	0.0 to 240.0 Hz	0.0 Hz
d3-04	Jump Frequency Width	0.0 to 20.0 Hz	1.0 Hz

Figure 5.19 shows the relationship between the Jump frequency and the output frequency.

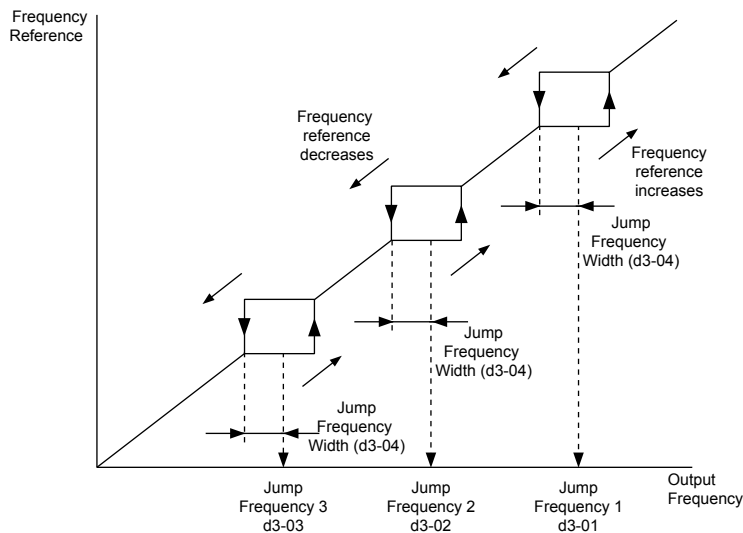

Figure 5.19 Jump Frequency Operation

- Note:**
1. The drive will use the active accel/decel time to pass through the specified dead band range, but will not allow continuous operation in that range.
  2. When setting more than one Jump frequency, make sure that  $d3-01 \geq d3-02 \geq d3-03$ .



## 5.6 E: Motor Parameters

E parameters cover V/f pattern and motor data settings.

### ◆ E1: V/f Pattern for Motor 1

#### ■ E1-01: Input Voltage Setting

Adjusts the levels of some protective features of the drive (overvoltage, Stall Prevention, etc.). Set this parameter to the nominal voltage of the AC power supply.

**NOTICE:** Set parameter E1-01 to match the input voltage of the drive. Drive input voltage (not motor voltage) must be set in E1-01 for the protective features to function properly. Failure to set the correct drive input voltage will result in improper drive operation.

No.	Parameter Name	Setting Range	Default
E1-01	Input Voltage Setting	190 to 240 V <I>	230 V <I>

<I> Values shown are specific to 208 Vac. Double the value for 408 Vac.

#### E1-01 Related Values

The input voltage setting determines the overvoltage and undervoltage detection levels, the KEB function, and the overvoltage suppression function.

Voltage	Setting Value of E1-01	(Approximate Values)
		Uv Detection Level (L2-05)
208 Vac	All settings	190 V
408 Vac	Setting > 460 V	440 V

#### ■ V/f Pattern Settings (E1-03)

The drive uses a V/f pattern to adjust the output voltage relative to the frequency reference. There are 15 different predefined V/f patterns (setting 0 to E) from which to select, each with varying voltage profiles, saturation levels (frequency at which maximum voltage is reached), and maximum frequencies. Additionally, one custom V/f pattern is available (setting F) that requires the user to create the pattern using parameters E1-04 through E1-10.

#### ■ E1-03: V/f Pattern Selection

Selects the V/f pattern for the drive and motor from 15 predefined patterns or creates a custom V/f pattern.

No.	Parameter Name	Setting Range	Default
E1-03	V/f Pattern Selection	0 to 9; A to F	F

#### Setting a Predefined V/f Pattern (Setting 0 to F)

Choose the V/f pattern that best meets the application demands from the table below. Set the correct value to E1-03. Parameter E1-05 can only be monitored, not changed.

- Note:**
- Setting an improper V/f pattern may result in low motor torque or increased current due to overexcitation.
  - Drive initialization does not reset parameter E1-03.

**Table 5.7 Predefined V/f Patterns**

Setting	Specification	Characteristic	Application
0	50 Hz	Constant torque	For general purpose applications. Torque remains constant regardless of changes to speed.
1	60 Hz		
2	60 Hz (with 50 Hz base)		
3	72 Hz (with 60 Hz base)		
4	50 Hz, Variable torque 1	Variable torque	For fans, pumps, and other applications where the required torque changes as a function of the speed.
5	50 Hz, Variable torque 2		
6	50 Hz, Variable torque 3		
7	50 Hz, Variable torque 4		

## 5.6 E: Motor Parameters

Setting	Specification	Characteristic	Application
8	50 Hz, Mid starting torque	High starting torque	Select high starting torque when: <ul style="list-style-type: none"> <li>• Wiring between the drive and motor exceeds 150 m.</li> <li>• A large amount of starting torque is required.</li> <li>• An AC reactor is installed.</li> </ul>
9	50 Hz, High starting torque		
A	60 Hz, Mid starting torque		
B	60 Hz, High starting torque		
C	90 Hz (with 60 Hz base)	Constant output	Output voltage is constant when operating at greater than 60 Hz.
D	120 Hz (with 60 Hz base)		
E	180 Hz (with 60 Hz base)		
F </>	60 Hz	Variable torque	Used for variable torque applications. The default setting is the same as V/f pattern Setting 7.

<1> Setting F enables a custom V/f pattern by changing parameters E1-05. When the bypass is shipped, the default values for parameter E1-05 are equal to predefined V/f pattern 1.

The following tables show details on predefined V/f patterns.

### Predefined V/f Patterns for Models Z1B1D002 to D024 and Z1B1B001 to B011

The values in the following graphs are specific to 208 Vac. Double the values for 480 Vac.

**Table 5.8 Constant Torque Characteristics, Settings 0 to 3**

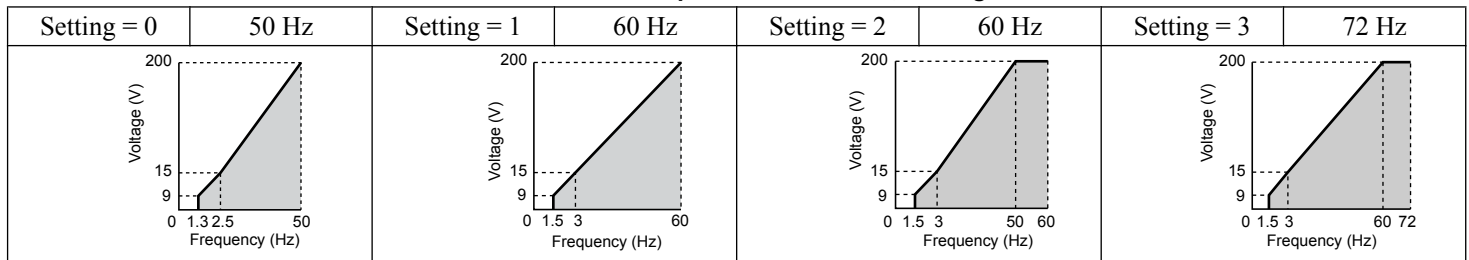

**Table 5.9 Variable Torque Characteristics, Settings 4 to 7**

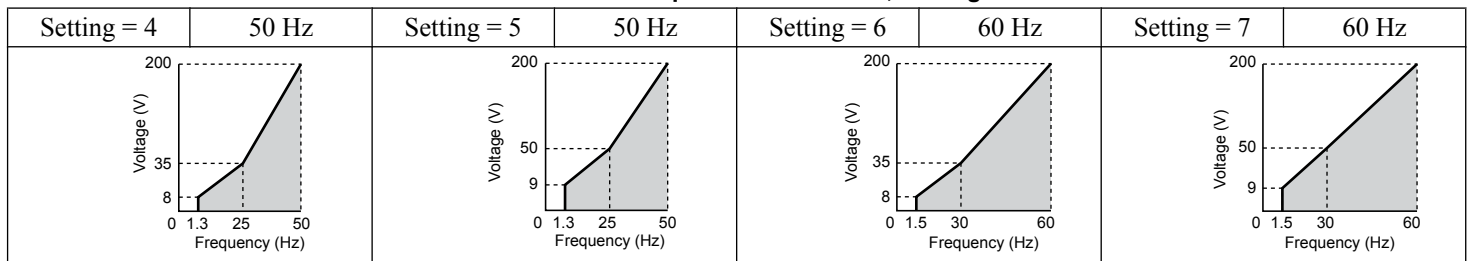

**Table 5.10 High Starting Torque, Settings 8 to B**

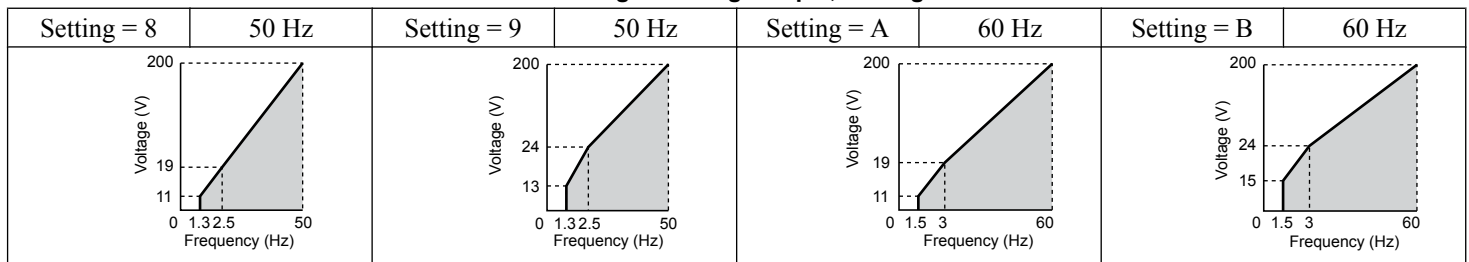

**Table 5.11 Rated Output Operation, Settings C to F**

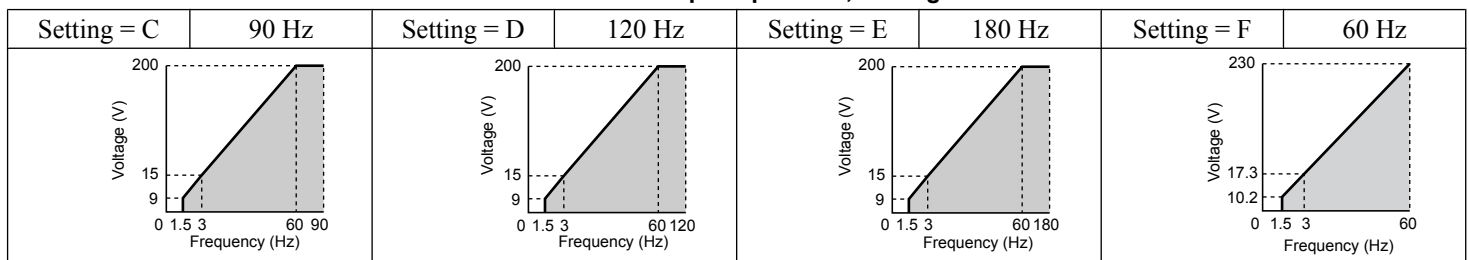

**Predefined V/f Patterns for Models Z1B1D030 to D211 and Z1B1B014 to B096**

The values in the following graphs are specific to 208 Vac. Double the values for 480 Vac.

**Table 5.12 Rated Torque Characteristics, Settings 0 to 3**

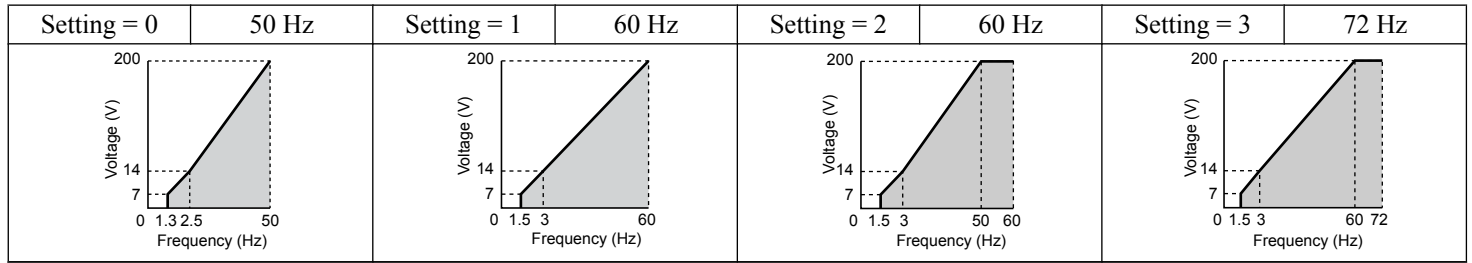

**Table 5.13 Variable Torque Characteristics, Settings 4 to 7**

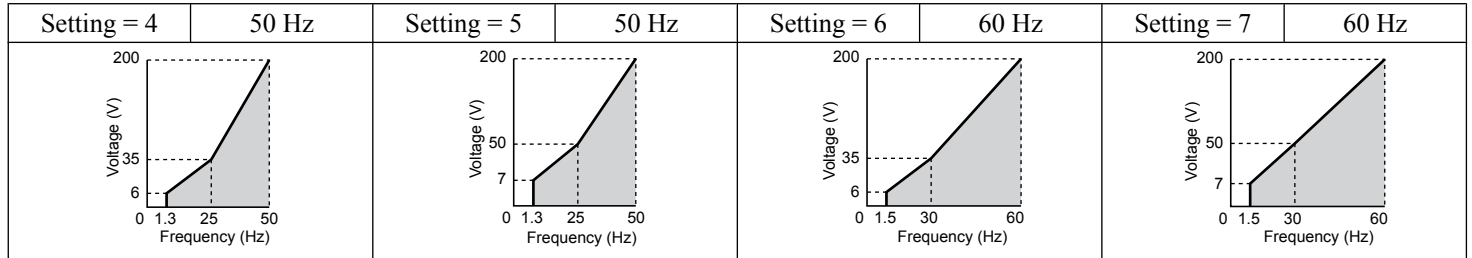

**Table 5.14 High Starting Torque, Settings 8 to B**

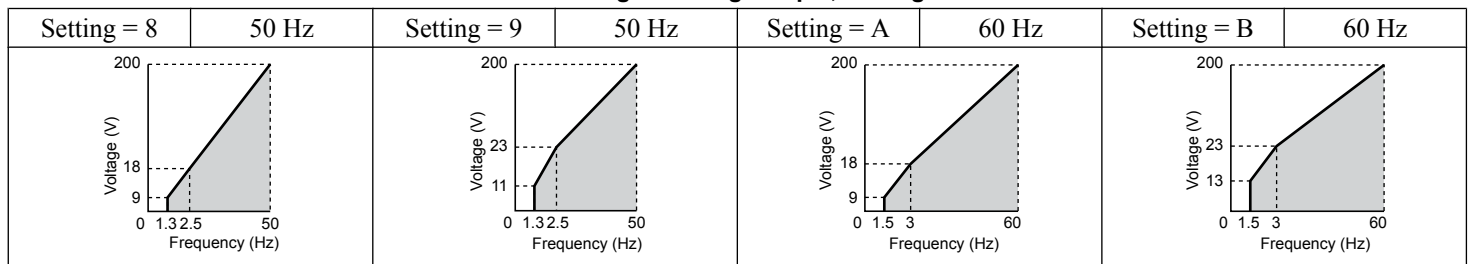

**Table 5.15 Constant Output, Settings C to F**

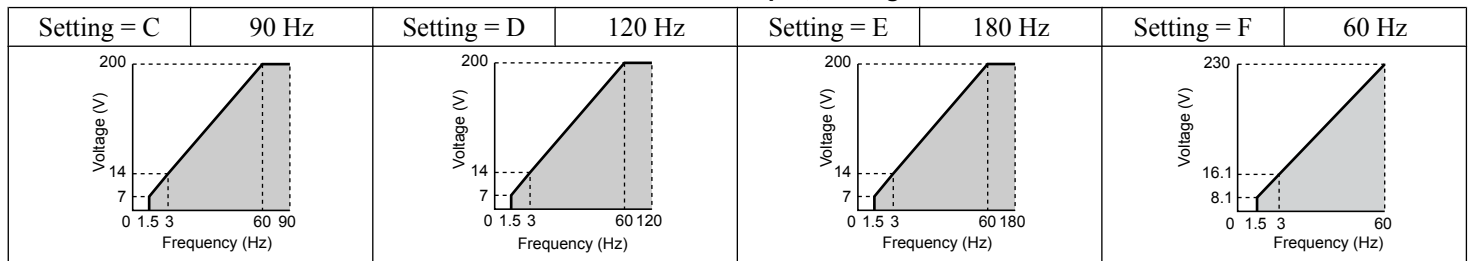

## 5.6 E: Motor Parameters

### Predefined V/f Patterns for Models Z1B1D273 and Z1B1B124 to B302

The values in the following graphs are specific to 208 Vac. Double the values for 480 Vac.

**Table 5.16 Rated Torque Characteristics, Settings 0 to 3**

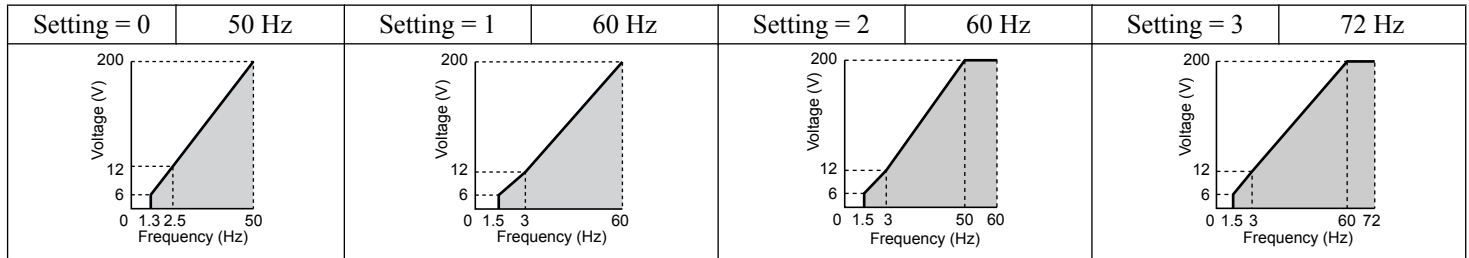

**Table 5.17 Variable Torque Characteristics, Settings 4 to 7**

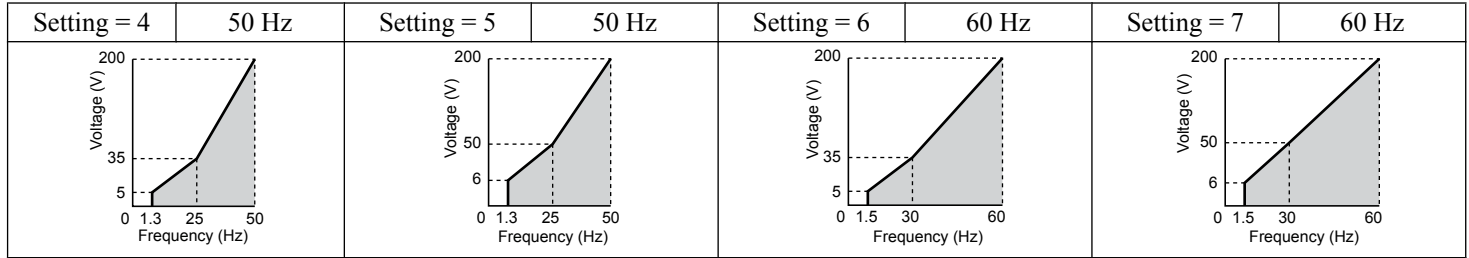

**Table 5.18 High Starting Torque, Settings 8 to B**

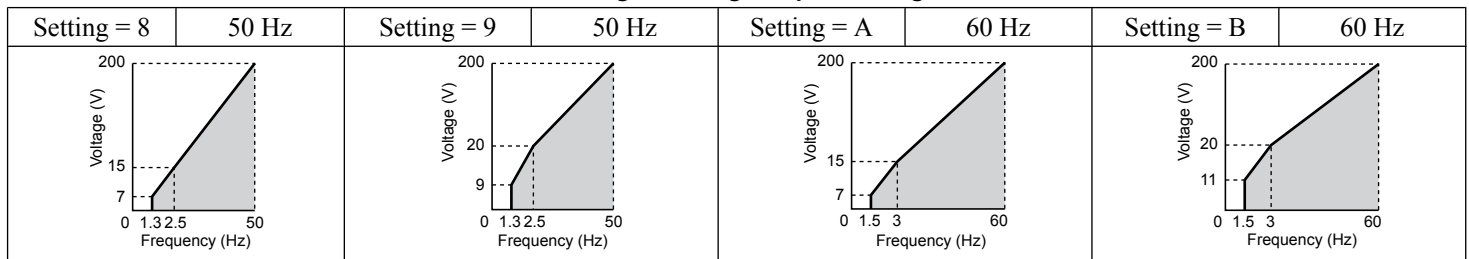

**Table 5.19 Constant Output, Settings C to F**

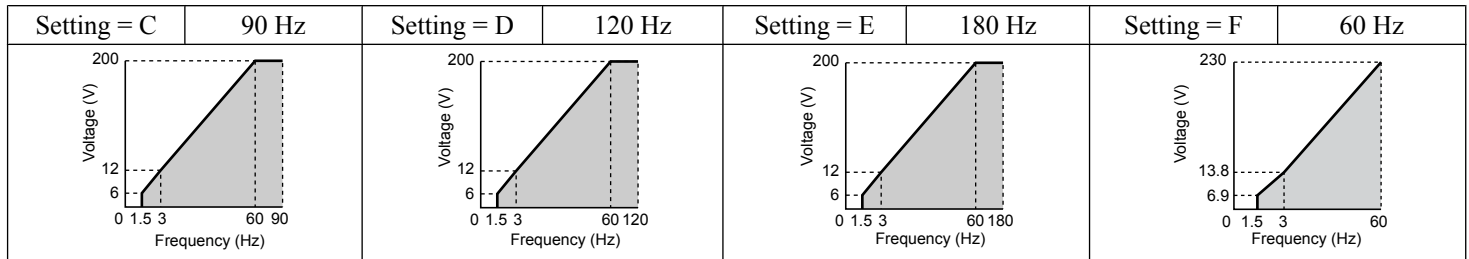

### Setting a Custom V/f Pattern (Setting F: Default)

Setting parameter E1-03 to F allows the user to set up a custom V/f pattern by changing parameter E1-05.

#### ■ V/f Pattern Settings E1-05

If E1-03 is set to a preset V/f pattern (i.e., a value other than F), the user can monitor the maximum voltage in parameters E1-05. To create a new V/f pattern, set E1-03 to F.

No.	Parameter Name	Setting Range	Default
E1-05	Maximum Voltage	0.0 to 255.0 V <1>	<2>

<1> Values shown are specific to 208 Vac. Double the value for 480 Vac.

<2> Default setting is determined by parameter E1-03, V/f Pattern Selection.

## ◆ E2: Motor 1 Parameters

These parameters contain the motor data needed for motor 1. Enter the motor data into these parameters when Auto-Tuning cannot be performed.

### ■ E2-01: Motor Rated Current

Provides motor control, protects the motor, and calculates torque limits. Set E2-01 to the full load amps (FLA) stamped on the motor nameplate.

No.	Parameter Name	Setting Range	Default
E2-01	Motor Rated Current	10% to 200% of the drive rated current	Determined by o2-04

**Note:** The number of decimal places in the parameter value depends on the drive model. *Refer to Defaults by Drive Model on page 372* for details.

### ■ E2-03: Motor No-Load Current

Set the no-load current for the motor in amperes when operating at the rated frequency and the no-load voltage. The drive sets E2-03 during the Auto-Tuning process (Rotational Auto-Tuning and Stationary Auto-Tuning 1, 2). The motor no-load current listed in the motor test report can also be entered to E2-03 manually. Contact the motor manufacturer to receive a copy of the motor test report.

No.	Parameter Name	Setting Range	Default
E2-03	Motor No-Load Current	0 to [E2-01] (unit: 0.01 A)	Determined by o2-04

**Note:** The number of decimal places in the parameter value depends on the drive model. This value has two decimal places (0.01 A) if the drive is set for a maximum applicable motor capacity up to and including 11 kW, and one decimal place (0.1 A) if the maximum applicable motor capacity is higher than 11 kW.

## 5.7 F: Options

### ◆ F6: Drive/Bypass Communications

#### ■ F6-01: Communications Error Operation Selection

Determines drive operation when a communication error occurs.

No.	Parameter Name	Setting Range	Default
F6-01	Communications Error Operation Selection	0 to 5	1

**Setting 0: Ramp to Stop (Use the Deceleration Time Set to C1-02)**

**Setting 1: Coast to Stop**

**Setting 2: Fast Stop (Use the Fast Stop Time Set to C1-09)**

**Setting 3: Alarm Only (Continue Operation)**

**Setting 4: Alarm Only (Continue Operation Using the Frequency Reference Set in d1-04)**

**Setting 5: Alarm Only (Use the Deceleration Time Set to C1-02)**

#### ■ F6-02: External Fault from Bypass Controller Detection Selection

Determines the detection method of an external fault initiated by the bypass controller (EF0).

No.	Parameter Name	Setting Range	Default
F6-02	External Fault from Bypass Controller Detection Selection	0, 1	0

**Setting 0: Always detected**

**Setting 1: Detection during Run only**

#### ■ F6-03: External Fault from Bypass Controller Operation Selection

Determines drive operation when an external fault is initiated by the bypass controller (EF0).

No.	Parameter Name	Setting Range	Default
F6-03	External Fault from Bypass Controller Operation Selection	0 to 3	1

**Setting 0: Ramp to stop**

**Setting 1: Coast to stop**

**Setting 2: Fast Stop**

**Setting 3: Alarm only (continue operation)**

## 5.8 H: Terminal Functions

H parameters assign functions to the external terminals.

### ◆ H1: Multi-Function Digital Inputs

#### ■ H1-03 to H1-07: Functions for Terminals S3 to S7

These parameters assign functions to the multi-function digital inputs. The various functions and settings are listed in [Table 5.20](#).

**Note:** Setting F has been added and Setting 13 has been removed in bypass controller software versions VST800298 and later.

No.	Parameter Name	Setting Range	Default
H1-03	Multi-Function Digital Input Terminal S3 Function Selection	3 to 60	24: External Fault
H1-04	Multi-Function Digital Input Terminal S4 Function Selection	3 to 60	14: Fault Reset
H1-05	Multi-Function Digital Input Terminal S5 Function Selection	3 to 60	3: Multi-Step Speed Reference 1
H1-06	Multi-Function Digital Input Terminal S6 Function Selection	3 to 60	4: Multi-Step Speed Reference 2
H1-07	Multi-Function Digital Input Terminal S7 Function Selection	3 to 60	6: Jog Reference Selection

**Table 5.20 Multi-Function Digital Input Terminal Settings**

Setting	Function	Page	Setting	Function	Page
3	Multi-Step Speed Reference 1	<a href="#">151</a>	13 <2>	Reverse Jog	<a href="#">152</a>
4	Multi-Step Speed Reference 2		14	Fault Reset	<a href="#">153</a>
6	Jog reference Selection	<a href="#">151</a>	19	PID Disable	<a href="#">153</a>
C	Analog Terminal Input Selection	<a href="#">151</a>	24	External Fault	<a href="#">153</a>
F <1>	Not Used (Through Mode)	<a href="#">151</a>	60	Motor Pre-Heat 1	<a href="#">153</a>
10	Up Command	<a href="#">151</a>			
11	Down Command				

<1> Available in bypass controller software versions VST800298 and later.

<2> Setting 13: Reverse Jog, is only available in bypass controller software versions VST800297 and earlier.

#### Settings 3 and 4: Multi-Step Speed Reference 1 and 2

Switches multi-step speed frequency references d1-01 to d1-04 by digital inputs. [Refer to d1: Frequency Reference on page 142](#) for details.

#### Setting 6: Jog Reference Selection

The Jog frequency set in parameter d1-17 becomes the frequency reference when the input terminal closes. [Refer to d1: Frequency Reference on page 142](#) for details.

#### Setting C: Analog Terminal Input Selection (Terminals A1 and A2)

When closed, the terminals specified in H3-14 are enabled. When open, the drive disregards the input signal to the analog terminals.

#### Setting F: Not Used (Through Mode)

**Note:** Available in bypass controller software versions VST800298 and later.

Select this setting when using the terminal in a pass-through mode. When set to F, an input does not trigger any function in the drive. Setting F, however, still allows the input status to be read out by a PLC via a communication option or MEMOBUS/Modbus communications.

#### Settings 10 and 11: Up/Down Function

The Up/Down function allows the frequency reference to be set by two push buttons when one digital input is programmed as the Up input (H1-□□= 10) to increase the frequency reference and the other digital input is programmed as the Down input (H1-□□= 11) to decrease the frequency reference.

The Up/Down function takes priority over the frequency references from the HOA keypad, the analog inputs, and the pulse input (b1-01 = 0, 1, 4). When using the Up/Down function, references provided by these sources will be disregarded.

The inputs operate as shown in the table below:

## 5.8 H: Terminal Functions

Status		Drive Operation
Up (10)	Down (11)	
Open	Open	Hold current frequency reference
Closed	Open	Increase frequency reference
Open	Closed	Decrease frequency reference
Closed	Closed	Hold current frequency reference

- Note:**
1. An oPE03 alarm occurs when only one of the Up/Down functions is programmed to a digital input.
  2. An oPE03 alarm occurs when the Up/Down function is assigned to the terminals and a different digital input is programmed for the Accel/decel ramp hold function. Refer to the Troubleshooting chapter in the User Manual packaged with the drive for more information on alarms.
  3. The Up/Down function can only be used for External reference 1. Consider this when using Up/Down and the external reference switching command (H1-□□ = 2).

### Using the Up/Down Function with Frequency Reference Hold (d4-01)

- If the frequency reference hold function is disabled (d4-01 = 0), the Up/Down frequency reference will be reset to 0 when the Run command is cleared or the power is cycled.
- When d4-01 = 1, the drive will save the frequency reference set by the Up/Down function. When the Run command or the power is cycled, the drive will restart with the saved reference value. Close the Up or Down input without an active Run command to reset the saved value.

### Using the Up/Down Function with Frequency Reference Limits

The value for the lower frequency reference limit depends on the parameter d4-10 setting. This value can be set by an analog input or parameter d2-02. When a Run command is applied, the lower limits function as follows:

- If the lower limit is set by d2-02 only, the drive accelerates to this limit as soon as a Run command is entered.
- If the lower limit is determined by an analog input only, the drive accelerates to the limit when both the Run command and an Up or Down command are active. The drive will not start running if only the Run command is active.
- If the lower limit is set by both an analog input and d2-02, and the analog limit is higher than the d2-02 value, the drive accelerates to the d2-02 value when a Run command is input. When the d2-02 value is reached, the drive accelerates to the analog limit only if an Up or Down command is set.

**Figure 5.20** shows an Up/Down function example with a lower frequency reference limit set by d2-02, and the frequency reference hold function both enabled and disabled.

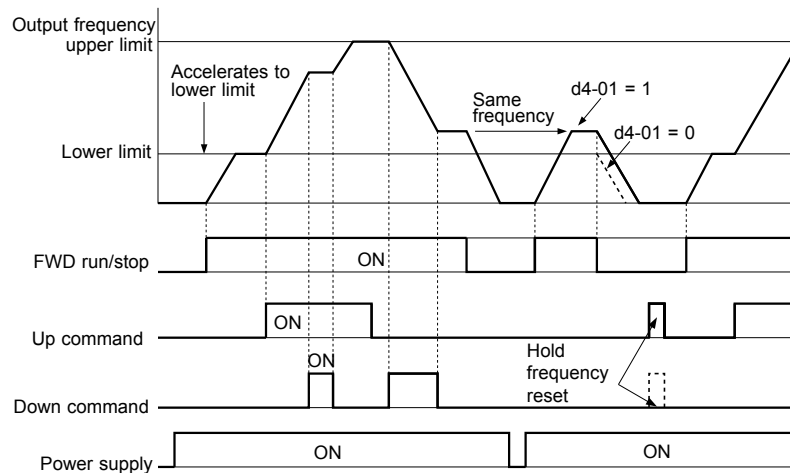

**Figure 5.20 Up/Down Command Operation**

### Setting 13: Reverse Jog

**Note:** Setting 13 is only available in bypass controller software versions VST800297 and earlier.

Digital inputs programmed as Reverse Jog (H1-□□ = 13) are Jog inputs that do not require a Run command. Closing the terminal set for Reverse Jog input will cause the drive to ramp to the Jog frequency reference (d1-17) in the reverse direction.

**Note:** The Reverse Jog command overrides all other frequency references. However, if the drive is set to prohibit reverse rotation (b1-04 = 1), activating Reverse Jog will have no effect.



**Setting 14: Fault Reset**

When the drive detects a fault condition, the fault output contact closes, the drive output shuts off, and the motor coasts to stop (specific stopping methods can be selected for some faults such as L1-04 for motor overheating). After removing the Run command, clear the fault either by pressing the RESET key on the HOA keypad or closing a digital input configured as a Fault Reset (H1-□□ = 14).

**Note:** Remove the Run command prior to resetting a fault. Fault Reset commands are ignored while the Run command is present.

**Setting 19: PI Disable**

Close a digital input to indefinitely disable the PI function. When the input is released, the drive resumes PI operation. *Refer to PI Block Diagram on page 130.*

**Setting 24: External Fault**

The External fault command stops the drive when problems occur with external devices.

To use the External fault command, set one of the multi-function digital inputs to 24. The HOA keypad will display EF□ where □ is the number of the terminal to which the external fault signal is assigned.

For example, if an external fault signal is input to terminal DI-3, “EF3” will be displayed.

The conditions of setting 24 are:

- Terminal status is normally open
- Detection condition is always detected
- Stopping method is coast to stop.

**Setting 60: Motor Pre-Heat 1**

A DC current can be circulated through the motor windings to create heat and prevent moisture from condensing on the wire. Motor Pre-Heating can only be initiated by closing a digital input programmed as a Motor Pre-Heat input (H1-□□ = 60). The level of the DC current used by the Motor Pre-Heat function is determined by b2-09<I>.

<I> Details on this function can be found in the standard Z1000 Programming Manual (SIEPC71061645) at [www.yaskawa.com](http://www.yaskawa.com).

A Run input will be given priority over a Motor Pre-Heat input and when the Run command is removed, the motor pre-heating will resume if the Motor Pre-Heat input is still closed.

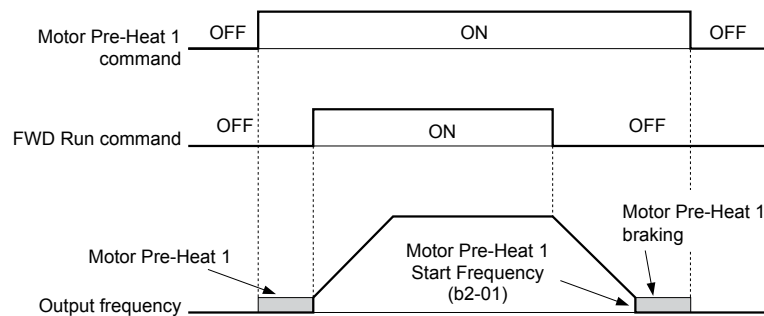

**Figure 5.21 Motor Pre-Heat 1 Input Timing Diagram**

**◆ H2: Multi-Function Digital Outputs**

**Note:** H2-□□ parameters are available in bypass controller software versions VST800298 and later.

**■ H2-01 to H2-03: Terminal M1-M2, M3-M4, and M5-M6 Function Selection**

The bypass has three multi-function output terminals. *Table 5.21* lists the functions available for these terminals using H2-01, H2-02, and H2-03.

No.	Parameter Name	Setting Range	Default
H2-01	Terminal M1-M2 Function Selection (relay)	0 to 160	0: During Run 1
H2-02	Terminal M3-M4 Function Selection (relay)	0 to 160	1: Zero Speed
H2-03	Terminal M5-M6 Function Selection (relay)	0 to 160	2: Speed Agree 1

## 5.8 H: Terminal Functions

**Table 5.21 Multi-Function Digital Output Terminal Settings**

Setting	Function	Page	Setting	Function	Page
0	During Run 1	154	14	User-Set Speed Agree 2	157
1	Zero Speed	154	15	Frequency Detection 3	158
2	Speed Agree 1	154	16	Frequency Detection 4	158
3	User-Set Speed Agree 1	155	17	Torque Detection 1 (N.C.)	157
4	Frequency Detection 1	155	1A	During Reverse	159
5	Frequency Detection 2	156	1B	During Baseblock 2 (N.C.)	159
6	Drive Ready	156	1E	Restart Enabled	159
7	DC Bus Undervoltage	156	20	Drive Overheat Pre-Alarm (oH)	159
8	During Baseblock 1 (N.O.)	156	2F	Maintenance Period	159
B	Torque Detection 1 (N.O.)	157	37	During Run 2	159
C	Frequency Reference Loss	157	39	Watt Hour Pulse Output	160
E	Fault	157	3D	During Speed Search	160
F	Through Mode	157	4C	During Fast Stop	160
10	Minor Fault	157	4D	oH Pre-Alarm Time Limit	160
11	Fault Reset Command Active	157	60	Internal Cooling Fan Alarm	160
13	Speed Agree 2	157	100 to 160	Functions 0 to 60 with Inverse Output	160

### Setting 0: During Run

The output closes when the drive is outputting a voltage.

Status	Description
Open	Drive is stopped.
Closed	A Run command is input or the drive is in deceleration or DC injection.

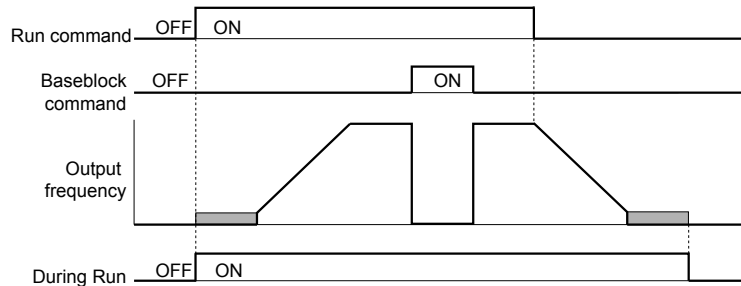
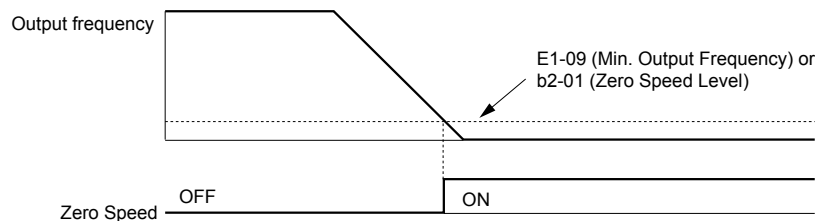

**Figure 5.22 During Run Time Chart**

### Setting 1: Zero Speed

The output closes when the output frequency or motor speed falls below the minimum output frequency set to E1-09 or b2-01.

Status	Description
Open	Output frequency is above the minimum output frequency set to E1-09 or b2-01
Closed	Output frequency is less than the minimum output frequency set to E1-09 or b2-01



**Figure 5.23 Zero-Speed Time Chart**

### Setting 2: Speed Agree 1 ( $f_{ref}/f_{out}$ Agree 1)

The output closes when the actual output frequency or motor speed is within the Speed Agree Width (L4-02) of the current frequency reference regardless of the direction.

Status	Description
Open	Output frequency or motor speed does not match the frequency reference while the drive is running.
Closed	Output frequency or motor speed is within the range of frequency reference $\pm L4-02$ .

**Note:** Detection works in forward and reverse.

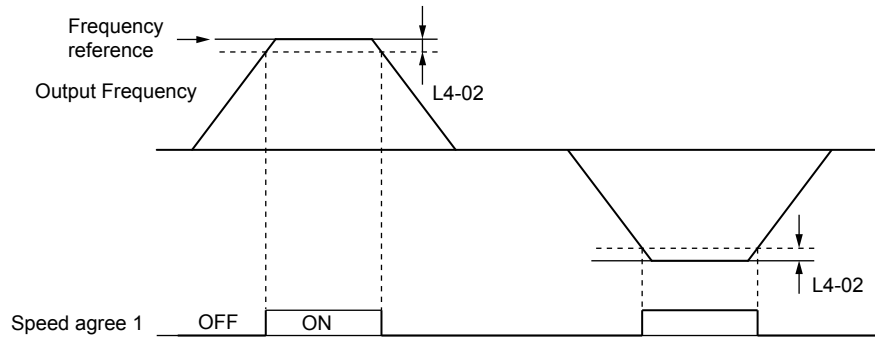

Figure 5.24 Speed Agree 1 Time Chart

### Setting 3: User-Set Speed Agree 1 ( $f_{ref}/f_{set}$ Agree 1)

The output closes when the actual output frequency or motor speed and the frequency reference are within the speed agree width ( $L4-02$ ) of the programmed speed agree level ( $L4-01$ ).

Status	Description
Open	Output frequency or motor speed and frequency reference are not both within the range of $L4-01 \pm L4-02$ .
Closed	Output frequency or motor speed and the frequency reference are both within the range of $L4-01 \pm L4-02$ .

**Note:** Frequency detection works in forward and reverse. The value of  $L4-01$  is used as the detection level for both directions.

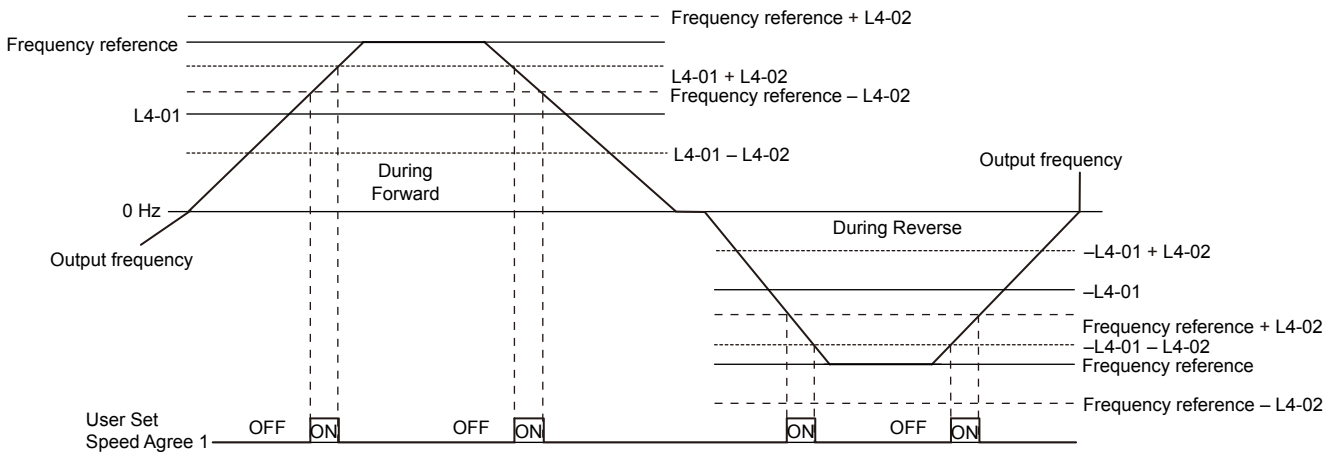

Figure 5.25 User Set Speed Agree 1 Time Chart

### Setting 4: Frequency Detection 1

The output opens when the output frequency or motor speed rises above the detection level set in  $L4-01$  plus the detection width set in  $L4-02$ . The terminal remains open until the output frequency or motor speed fall below the level set in  $L4-01$ .

Status	Description
Open	Output frequency or motor speed exceeded $L4-01 + L4-02$ .
Closed	Output frequency or motor speed is below $L4-01$ or has not exceeded $L4-01 + L4-02$ .

**Note:** Frequency detection works in forward and reverse. The value of  $L4-01$  is used as the detection level for both directions.

## 5.8 H: Terminal Functions

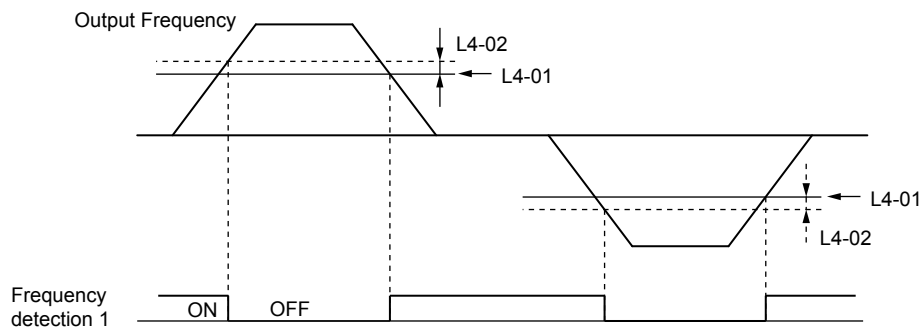

Figure 5.26 Frequency Detection 1 Time Chart

### Setting 5: Frequency Detection 2

The output closes when the output frequency or motor speed is above the detection level set in L4-01. The terminal remains closed until the output frequency or motor speed fall below L4-01 minus the setting of L4-02.

Status	Description
Open	Output frequency or motor speed is below L4-01 minus L4-02 or has not exceeded L4-01.
Closed	Output frequency or motor speed exceeded L4-01.

**Note:** Frequency detection works in forward and reverse. The value of L4-01 is used as the detection level for both directions.

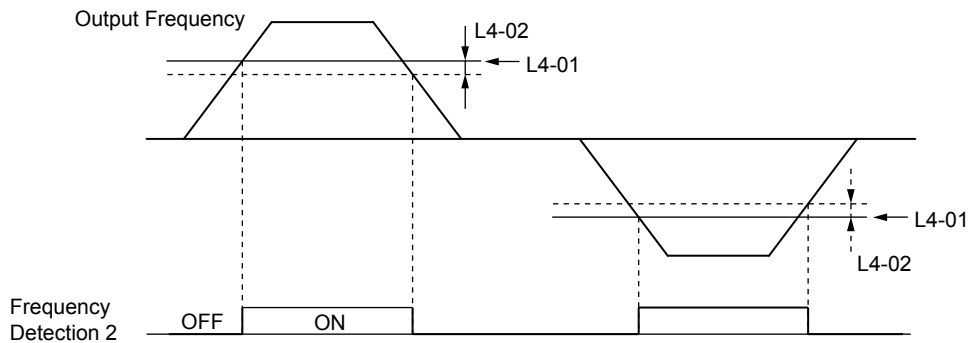

Figure 5.27 Frequency Detection 2 Time Chart

### Setting 6: Drive Ready

The output closes when the drive is ready to operate the motor. The terminal will not close under the conditions listed below, and any Run commands will be disregarded.

- When the power is shut off
- During a fault
- When the internal power supply of the drive has malfunctioned
- When a parameter setting error makes it impossible to run
- Although stopped, an overvoltage or undervoltage situation occurs
- While editing a parameter in the Programming Mode (when b1-08 = 0)

### Setting 7: DC Bus Undervoltage

The output closes when the DC bus voltage or control circuit power supply drops below the trip level set in L2-05. A fault in the DC bus circuit will also cause the terminal set for “DC bus undervoltage” to close.

Status	Description
Open	DC bus voltage is above the level set to L2-05.
Closed	DC bus voltage has fallen below the trip level set to L2-05.

### Setting 8: During Baseblock 1 (N.O.)

The output closes to indicate that the drive is in a baseblock state. While in baseblock, output transistors do not switch and no main circuit voltage is output.

Status	Description
Open	Drive is not in a baseblock state.
Closed	Baseblock is being executed.

### Settings B and 17: Torque Detection 1 (N.O., N.C.)

These digital output functions signal an overtorque or undertorque situation to an external device.

Set up the torque detection levels and select the output function from the table below.

Setting	Status	Description
B	Closed	Torque detection 1 (N.O.): Output current/torque exceeds (overtorque detection) or is below (undertorque detection) the torque value set in parameter L6-02 for longer than the time specified in parameter L6-03.
17	Open	Torque detection 1 (N.C.): Output current/torque exceeds (overtorque detection) or is below (undertorque detection) the torque value set in parameter L6-02 for longer than the time specified in parameter L6-03.

### Setting C: Frequency Reference Loss

The output closes when frequency reference loss is detected.

### Setting E: Fault

The output closes when the drive faults (excluding CPF00 and CPF01 faults).

### Setting F: Through Mode

Select this setting when using the terminal in a pass-through mode. When set to F, an output does not trigger any function in the drive. Setting F, however, still allows the output status to be read by a PLC via a communication option or MEMOBUS/Modbus communications.

### Setting 10: Minor Fault

The output closes when a minor fault condition is present.

### Setting 11: Fault Reset Command Active

The output closes when there is an attempt to reset a fault situation from the control circuit terminals, via serial communications, or using a communications option card.

### Setting 13: Speed Agree 2 ( $f_{ref}/f_{out}$ Agree 2)

The output closes when the actual output frequency or motor speed is within the speed agree width (L4-04) of the current frequency reference, regardless of the direction.

Status	Description
Open	Output frequency or motor speed does not match the frequency reference while the drive is running.
Closed	Output frequency or motor speed is within the range of frequency reference $\pm L4-04$ .

**Note:** Detection works in forward and reverse.

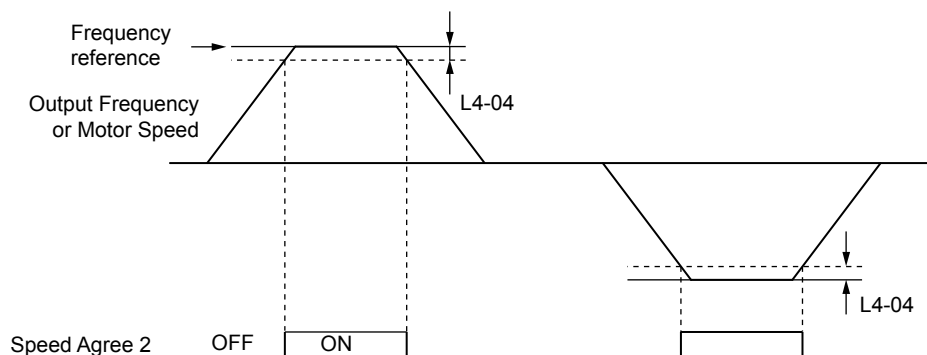

Figure 5.28 Speed Agree 2 Time Chart

### Setting 14: User-Set Speed Agree 2 ( $f_{ref}/f_{set}$ Agree 2)

The output closes when the actual output frequency or motor speed and the frequency reference are within the speed agree width (L4-04) of the programmed speed agree level (L4-03).

## 5.8 H: Terminal Functions

Status	Description
Open	Output frequency or motor speed and frequency reference are both outside the range of $L4-03 \pm L4-04$ .
Closed	Output frequency or motor speed and the frequency reference are both within the range of $L4-03 \pm L4-04$ .

**Note:** The detection level  $L4-03$  is a signed value; detection works in the specified direction only.

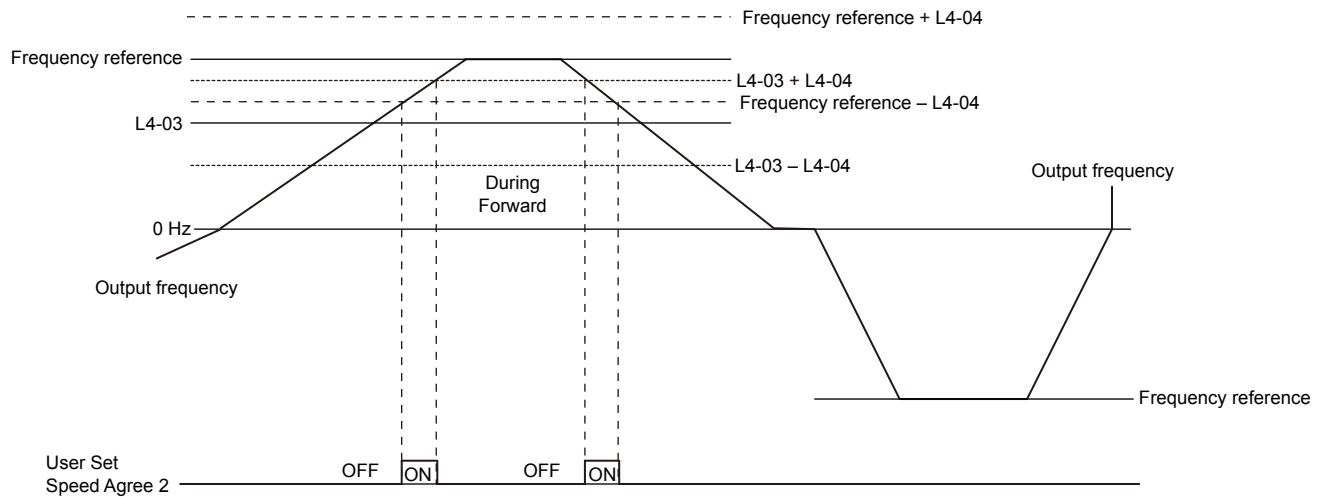
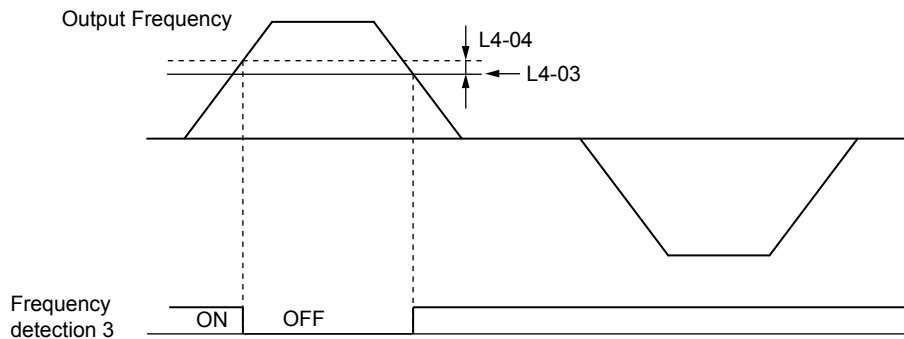

**Figure 5.29** User-Set Speed Agree 2 Example with a Positive  $L3-04$  Value

### Setting 15: Frequency Detection 3

The output opens when the output frequency or motor speed rises above the detection level set in  $L4-03$  plus the detection with set in  $L4-04$ . The terminal remains open until the output frequency or motor speed falls below the level set in  $L4-03$ . The detection level  $L4-03$  is a signed value; detection works in the specified direction only.

Status	Description
Open	Output frequency or motor speed exceeded $L4-03$ plus $L4-04$ .
Closed	Output frequency or motor speed is below $L4-03$ or has not exceeded $L4-03$ plus $L4-04$ .



**Figure 5.30** Frequency Detection 3 Example with a Positive  $L3-04$  Value

### Setting 16: Frequency Detection 4

The output closes when the output frequency or motor speed is above the detection level set in  $L4-03$ . The terminal remains closed until the output frequency or motor speed falls below  $L4-03$  minus the setting of  $L4-04$ .

Status	Description
Open	Output frequency or motor speed is below $L4-03$ minus $L4-04$ or has not exceeded $L4-03$ .
Closed	Output frequency or motor speed exceeded $L4-03$ .

**Note:** The detection level  $L4-03$  is a signed value; detection works in the specified direction only.

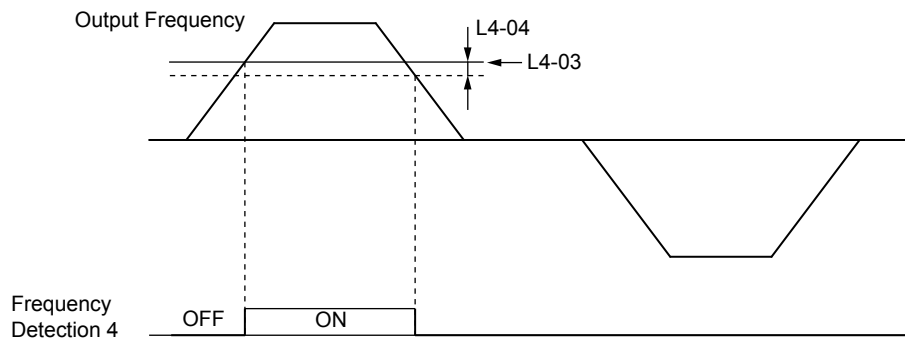

Figure 5.31 Frequency Detection 4 Example with Positive L3-04 Value

**Setting 1A: During Reverse**

The output closes when the drive is running the motor in the reverse direction.

Status	Description
Open	Motor is being driven in the forward direction or stopped.
Closed	Motor is being driven in reverse.

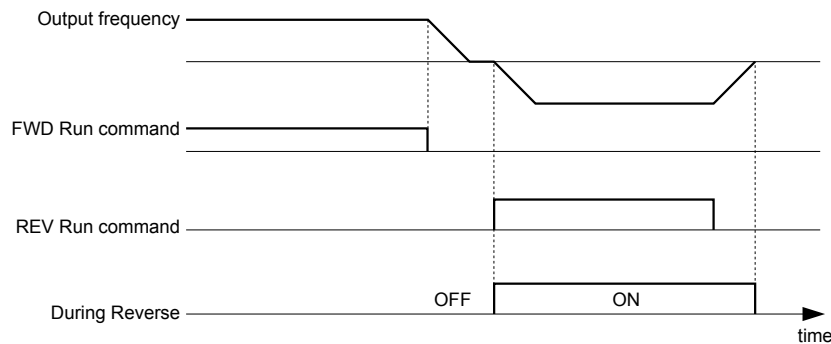

Figure 5.32 Reverse Direction Output Example Time Chart

**Setting 1B: During Baseblock 2 (N.C.)**

The output opens to indicate that the drive is in a baseblock state. While baseblock is executed, output transistors do not switch and no main circuit voltage is output.

Status	Description
Open	Baseblock is being executed.
Closed	Drive is not in a baseblock state.

**Setting 1E: Restart Enabled**

The output closes when the drive attempts to restart after a fault has occurred.

The fault restart function allows the drive to automatically clear a fault. The terminal set to 1E will close after the fault is cleared and the drive has attempted to restart. If the drive cannot successfully restart within the number of attempts permitted by L5-01, a fault will be triggered and the terminal set to 1E will open.

**Setting 20: Drive Overheat Pre-Alarm (oH)**

The output closes when the drive heatsink temperature reaches the level specified by parameter L8-02.

**Setting 2F: Maintenance Period**

The output closes when the cooling fan, DC bus capacitors, or DC bus pre-charge relay may require maintenance as determined by the estimated performance life span of those components. Components performance life is displayed as a percentage on the HOA keypad screen.

**Setting 37: During Run 2**

The output closes when the drive is outputting a frequency.

## 5.8 H: Terminal Functions

Status	Description
Open	Drive is stopped or one of the following functions is being performed: baseblock, DC Injection Braking, Short Circuit Braking.
Closed	Drive is outputting frequency.

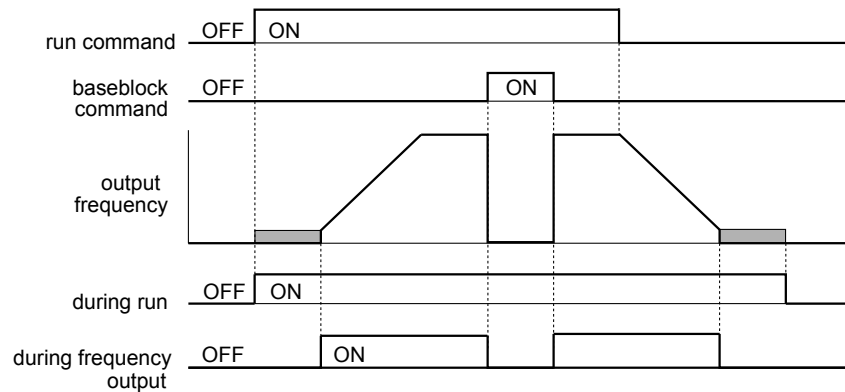

Figure 5.33 During Frequency Output Time Chart

### Setting 39: Watt Hour Pulse Output

Outputs a pulse to indicate the watt hours.

### Setting 3D: During Speed Search

The output terminal closes while Speed Search is being performed.

### Setting 4C: During Fast Stop

The output terminal closes when a Fast Stop is being executed. .

### Setting 4D: oH Pre-Alarm Time Limit

The output terminal closes when the drive is reducing the speed due to a drive overheat alarm (L8-03 = 4) and the overheat alarm has not disappeared after 10 frequency reduction operation cycles.

### Setting 60: Internal Cooling Fan Alarm

The output closes when the drive internal cooling fan has failed.

### Setting 100 to 160: Functions 0 to 60 with Inverse Output

These settings have the same function as settings 0 to 60, but with inverse output. Set as 1□□, where the “1” indicates inverse output and the last two digits specify the setting number of the function.

Examples:

- Set 108 for inverse output of “8: During Baseblock 1 (N.O.)”.
- Set 14D for inverse output of “4D: oH Pre-Alarm Time Limit”.

## ◆ H3: Multi-Function Analog Inputs

The drive is equipped with multi-function analog input terminals: A1 and A2. [Refer to Multi-Function Analog Input Terminal Settings on page 163](#) for a listing of the functions that can be set to these terminals.

### ■ H3-01: Terminal A1 Signal Level Selection

Selects the input signal level for analog input A1. Set jumper S1 on the terminal board accordingly for voltage input or current input.

No.	Name	Setting Range	Default
H3-01	Terminal A1 Signal Level Selection	0 to 3	0

### Setting 0: 0 to 10 V with Zero Limit

The input level is 0 to 10 Vdc with zero limit. The minimum input level is limited to 0%, so that a negative input signal due to gain and bias settings will be read as 0%.



**Setting 1: 0 to 10 V without Zero Limit**

The input level is 0 to 10 Vdc without zero limit. If the resulting voltage is negative after being adjusted by gain and bias settings, then the motor will rotate in reverse.

**Setting 2: 4 to 20 mA Current Input**

The input level is 4 to 20 mA. Negative input values by negative bias or gain settings are limited to 0%.

**Setting 3: 0 to 20 mA Current Input**

The input level is 0 to 20 mA. Negative input values by negative bias or gain settings are limited to 0%.

**■ H3-02: Terminal A1 Function Selection**

Selects the input signal level for analog input A1. *Refer to Multi-Function Analog Input Terminal Settings on page 163* for instructions on adjusting the signal level.

No.	Name	Setting Range	Default
H3-02	Terminal A1 Function Selection	0 to 26	0

**■ H3-03, H3-04: Terminal A1 Gain and Bias Settings**

Parameter H3-03 sets the level of the selected input value that is equal to 10 Vdc (20 mA) input at terminal A1 (gain).

Parameter H3-04 sets the level of the selected input value that is equal to 0 V (4 mA, 0 mA) input at terminal A1 (bias).

Use both parameters to adjust the characteristics of the analog input signal to terminal A1.

No.	Name	Setting Range	Default
H3-03	Terminal A1 Gain Setting	-999.9 to 999.9%	100.0%
H3-04	Terminal A1 Bias Setting	-999.9 to 999.9%	0.0%

**Setting Examples**

- Gain H3-03 = 200%, bias H3-04 = 0, terminal A1 as frequency reference input (H3-02 = 0):

A 10 Vdc input is equivalent to a 200% frequency reference and 5 Vdc is equivalent to a 100% frequency reference. Since the drive output is limited by the maximum frequency parameter (E1-04), the frequency reference will be equal to E1-04 above 5 Vdc.

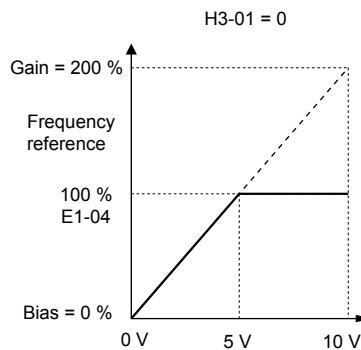

**Figure 5.34 Frequency Reference Setting by Analog Input with Increased Gain**

- Gain H3-03 = 100%, bias H3-04 = -25%, terminal A1 as frequency reference input:

An input of 0 Vdc will be equivalent to a -25% frequency reference.

When parameter H3-01 = 0, the frequency reference is 0% between 0 and 2 Vdc input.

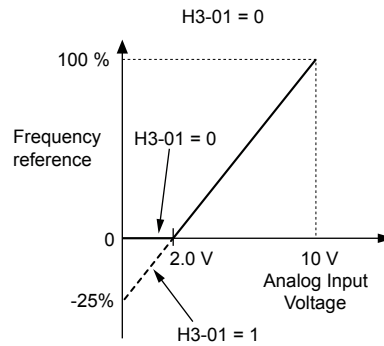

Figure 5.35 Frequency Reference Setting by Analog Input with Negative Bias

### ■ H3-09: Terminal A2 Signal Level Selection

Selects the input signal level for analog input A2. Set Jumper S1 on the terminal board accordingly for a voltage input or current input.

No.	Name	Setting Range	Default
H3-09	Terminal A2 Signal Level Selection	0 to 3	2

#### Setting 0: 0 to 10 V with Zero Limit

The input level is 0 to 10 Vdc. Negative input values will be limited to 0. [Refer to Setting 0: 0 to 10 V with Zero Limit on page 160.](#)

#### Setting 1: 0 to 10 V without Zero Limit

The input level is 0 to 10 Vdc. Negative input values will be accepted. [Refer to Setting 1: 0 to 10 V without Zero Limit on page 161.](#)

#### Setting 2: 4 to 20 mA Current Input

The input level is 4 to 20 mA. Negative input values by negative bias or gain settings will be limited to 0%.

#### Setting 3: 0 to 20 mA Current Input

The input level is 0 to 20 mA. Negative input values by negative bias or gain settings will be limited to 0%.

### ■ H3-10: Terminal A2 Function Selection

Determines the function assigned to analog input terminal A2. [Refer to Multi-Function Analog Input Terminal Settings on page 163](#) for a list of functions and descriptions.

No.	Name	Setting Range	Default
H3-10	Terminal A2 Function Selection	0 to 26	0

### ■ H3-11, H3-12: Terminal A2 Gain and Bias Setting

Parameter H3-11 sets the level of the input value selected that is equal to 10 Vdc input or 20 mA input to terminal A2.

Parameter H3-12 sets the level of the input value selected that is equal to 0 V, 4 mA or 0 mA input at terminal A2.

Use both parameters to adjust the characteristics of the analog input signal to terminal A2. The setting works in the same way as parameters H3-03 and H3-04 for analog input A1.

No.	Name	Setting Range	Default
H3-11	Terminal A2 Gain Setting	-999.9 to 999.9%	100.0%
H3-12	Terminal A2 Bias Setting	-999.9 to 999.9%	0.0%

### ■ H3-13: Analog Input Filter Time Constant

Parameter H3-13 sets the time constant for a first order filter that will be applied to the analog inputs.

An analog input filter prevents erratic drive control when using a “noisy” analog reference. Drive operation becomes more stable as the programmed time becomes longer, but it also becomes less responsive to rapidly changing analog signals.

No.	Name	Setting Range	Default
H3-13	Analog Input Filter Time Constant	0.00 to 2.00 s	0.03 s

### ■ H3-14: Analog Input Terminal Enable Selection

When one of the multi-function digital input parameters is set for “Analog input enable” (H1-□□ = C), the value set to H3-14 determines which analog input terminals are enabled and which terminals are disabled when the input is closed. All analog input terminals will be enabled all of the time if H1-□□ is not set to C.

No.	Name	Setting Range	Default
H3-14	Analog Input Terminal Enable Selection	1 to 3	2

**Setting 1: A1 Only Enabled**

**Setting 2: A2 Only Enabled**

**Setting 3: Terminals A1 and A2**

### ■ H3-16 and H3-17: Terminal A1/A2 Offset

Set the offset level of the selected input value to terminals A1 or A2 that is equal to 0 Vdc input. These parameters rarely require adjustment.

No.	Name	Setting Range	Default
H3-16	Terminal A1 Offset	-500 to 500	0
H3-17	Terminal A2 Offset	-500 to 500	0

### ■ Multi-Function Analog Input Terminal Settings

See [Table 5.22](#) for information on how H3-02 and H3-10 determine functions for terminals A1 and A2.

**Note:** The scaling of all input functions depends on the gain and bias settings for the analog inputs. Set these to appropriate values when selecting and adjusting analog input functions.

**Table 5.22 Multi-Function Analog Input Terminal Settings**

Setting	Function	Page	Setting	Function	Page
0	Frequency Bias	<a href="#">163</a>	B	PI Feedback	<a href="#">165</a>
1	Frequency Gain	<a href="#">163</a>	C	PI Setpoint	<a href="#">165</a>
2	Auxiliary Frequency Reference 1	<a href="#">163</a>	D	Frequency Bias	<a href="#">165</a>
3	Auxiliary Frequency Reference 2	<a href="#">164</a>	E	Motor Temperature (PTC Input)	<a href="#">165</a>
4	Output Voltage Bias	<a href="#">164</a>	F	Through Mode	<a href="#">165</a>
5	Accel/Decel Time Gain	<a href="#">164</a>	16	Differential PI Feedback	<a href="#">165</a>
6	DC Injection Braking Current	<a href="#">164</a>	1F <1>	HAND Reference	<a href="#">165</a>
7	Overtorque/Undertorque Detection Level	<a href="#">164</a>	25	Secondary PI Setpoint	<a href="#">165</a>
8	Stall Prevention Level During Run	<a href="#">164</a>	26	Secondary PI Feedback	<a href="#">165</a>
9	Output Frequency Lower Limit Level	<a href="#">165</a>			

<1> Setting 1F is “HAND Reference” in bypass controller software versions VST800298 and later. Setting 1F is “Not Used (Through Mode)” in bypass controller software versions VST800297 and earlier.

#### Setting 0: Frequency Bias

The input value of an analog input set to this function will be added to the analog frequency reference value. When the frequency reference is supplied by a different source other than the analog inputs, this function will have no effect. Use this setting also when only one of the analog inputs is used to supply the frequency reference.

By default, analog inputs A1 and A2 are set for this function. Simultaneously using A1 and A2 increases the frequency reference by the total of all inputs.

Example: If the analog frequency reference from analog input terminal A1 is 50% and a bias of 20% is applied by analog input terminal A2, the resulting frequency reference will be 70% of the maximum output frequency.

#### Setting 1: Frequency Gain

The input value of an analog input set to this function will be multiplied with the analog frequency reference value.

Example: If the analog frequency reference from analog input terminal A1 is 80% and a gain of 50% is applied from analog input terminal A2, the resulting frequency reference will be 40% of the maximum output frequency.

#### Setting 2: Auxiliary Reference 1

Sets the auxiliary frequency reference 1 when multi-step speed operation is selected. [Refer to Multi-Step Speed Selection on page 142](#) for details.

## 5.8 H: Terminal Functions

### Setting 3: Auxiliary Reference 2

Sets the auxiliary frequency reference 2 when multi-step speed operation is selected. [Refer to Multi-Step Speed Selection on page 142](#) for details.

### Setting 4: Output Voltage Bias

Voltage bias boosts the output voltage of the V/f curve as a percentage of the maximum output voltage (E1-05). Available only when using V/f Control.

### Setting 5: Accel/Decel Time Gain

Adjusts the gain level for the acceleration and deceleration times set to parameters C1-01 through C1-08.

The drive acceleration time is calculated by multiplying the gain level to C1-□□ as follows:

$C1-□□ \times \text{Accel/decel time gain} = \text{Drive accel/decel time}$

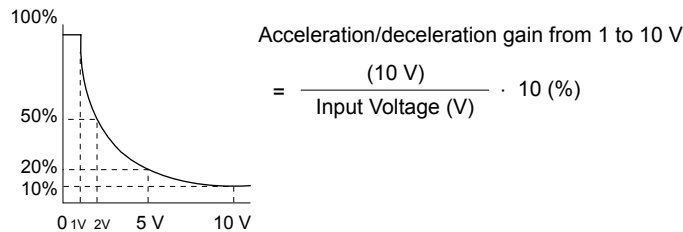

Figure 5.36 Accel/Decel Time Gain with Analog Input Terminal

### Setting 6: DC Injection Braking Current

The current level used for DC Injection Braking is set as a percentage of the drive rated current.

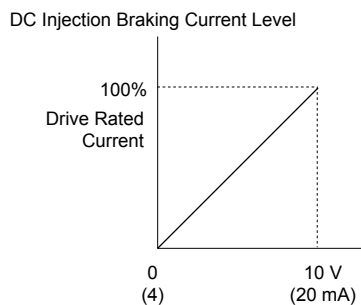

Figure 5.37 DC Injection Braking Current Using an Analog Input Terminal

### Setting 7: Torque Detection Level

Using this setting, the overtorque/undertorque detection level for torque detection 1 (L6-01) can be set by an analog input. The analog input replaces the level set to L6-02. An analog input of 100% (10 V or 20 mA) sets a torque detection level equal to 100% drive rated current/motor rated torque. Adjust the analog input gain if higher detection level settings are required. [Refer to L6: Torque Detection on page 176](#) for details on torque detection.

### Setting 8: Stall Prevention Level

Allows an analog input signal to adjust the Stall Prevention level. [Figure 5.38](#) shows the setting characteristics. The drive will use the lower value of the Stall Prevention level set to L3-06 or the level coming from the selected analog input terminal.

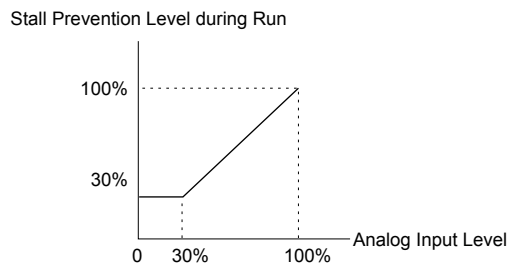

Figure 5.38 Stall Prevention During Run Using an Analog Input Terminal

**Setting 9: Output Frequency Lower Limit Level**

The user can adjust the lower limit of the output frequency using an analog input signal.

**Setting B: PI Feedback**

Supplies the PI feedback value. This setting requires PI operation to be enabled in b5-01. [Refer to PI Feedback Input Methods on page 129.](#)

**Setting C: PI Setpoint**

Supplies the PI setpoint value and makes the frequency reference selected in parameter b1-01 no longer the PI setpoint. PI operation to be enabled in b5-01 to use this setting. [Refer to PI Setpoint Input Methods on page 128.](#)

**Setting D: Frequency Bias**

The input value of an analog input set to this function will be added to the frequency reference. This function can be used with any frequency reference source.

**Setting E: Motor Temperature**

In addition to motor overload fault detection oL1, it is possible to use a PTC (Positive Temperature Coefficient) thermistor for motor insulation protection.

**Setting F: Through Mode**

When set to F, an input does not affect any drive function, but the input level can still be read out by a PLC via a BACnet communication or MEMOBUS/Modbus communications.

**Setting 16: Differential PI Feedback**

If an analog value is set for this function, the PI controller is set for differential feedback. The difference of the PI feedback input value and the differential feedback input value builds the feedback value used to calculate the PI input. [Refer to PI Feedback Input Methods on page 129.](#)

**Setting 1F: HAND Reference**

Sets the frequency reference when in HAND Mode and parameter Z1-41, HAND Speed Reference Selection, is set to 1 (Analog).

**Note:** Setting 1F is “HAND Reference” in bypass controller software versions VST800298 and later.

**Setting 1F: Through Mode**

Set this value when using the terminal in the pass-through mode.

**Note:** Setting 1F is “Not Used (Through Mode)” in bypass controller software versions VST800297 and earlier.

**Setting 25: Secondary PI Setpoint**

10 V = S3-02 (Maximum Output Frequency).

**Setting 26: Secondary PI Feedback**

10 V = S3-02 (Maximum Output Frequency).

**◆ H4: Multi-Function Analog Outputs**

These parameters assign functions to analog output terminals FM and AM for monitoring a specific aspect of drive performance.

**■ H4-01, H4-04: Multi-Function Analog Output Terminal FM, AM Monitor Selection**

Sets the desired drive monitor parameter U□-□□ to output as an analog value via terminal FM and AM. [Refer to U: Monitor Parameters on page 195](#) for a list of all monitors. The “Analog Output Level” column indicates whether a monitor can be used for analog output.

Example: Enter “103” for U1-03.

No.	Name	Setting Range	Default
H4-01	Multi-Function Analog Output Terminal FM Monitor Selection	000 to 655	102
H4-04	Multi-Function Analog Output Terminal AM Monitor Selection	000 to 655	103

A setting of 031 or 000 applies no drive monitor to the analog output. With this setting, terminal functions as well as FM and AM output levels can be set by a PLC via a communication option or MEMOBUS/Modbus (through mode).

## 5.8 H: Terminal Functions

### ■ H4-02, H4-03: Multi-Function Analog Output Terminal FM Gain and Bias H4-05, H4-06: Multi-Function Analog Output Terminal AM Gain and Bias

Parameters H4-02 and H4-05 set the terminal FM and AM output signal level when the value of the selected monitor is at 100%. Parameters H4-03 and H4-06 set the terminal FM and AM output signal level when the value of the selected monitor is at 0%. Both are set as a percentage, where 100% equals 10 Vdc or 20 mA analog output and 0% equals 0 V or 4 mA. The output voltage of both terminals is limited to +/-10 Vdc.

The output signal range can be selected between 0 to +10 Vdc or -10 to +10 Vdc, or 4 to 20 mA using parameter H4-07 and H4-08. *Figure 5.39* illustrates how gain and bias settings work.

No.	Name	Setting Range	Default
H4-02	Multi-Function Analog Output Terminal FM Gain	-999.9 to 999.9%	100.0%
H4-03	Multi-Function Analog Output Terminal FM Bias	-999.9 to 999.9%	0.0%
H4-05	Multi-Function Analog Output Terminal AM Gain	-999.9 to 999.9%	50.0%
H4-06	Multi-Function Analog Output Terminal AM Bias	-999.9 to 999.9%	0.0%

#### Using Gain and Bias to Adjust Output Signal Level

When viewing a gain setting parameter (H4-02 or H4-05) on the HOA keypad, the analog output will supply a voltage signal equal to 100% of the monitor value (including changes made from bias and gain settings). When viewing a bias setting parameter (H4-03 or H4-06), the analog output voltage will supply a signal equal to 0% monitor value.

Example 1: Set H4-02 to 50% for an output signal of 5 V at terminal FM when the monitored value is at 100%.

Example 2: Set H4-02 to 150% for an output signal of 10 V at terminal FM when the monitored value is at 76.7%.

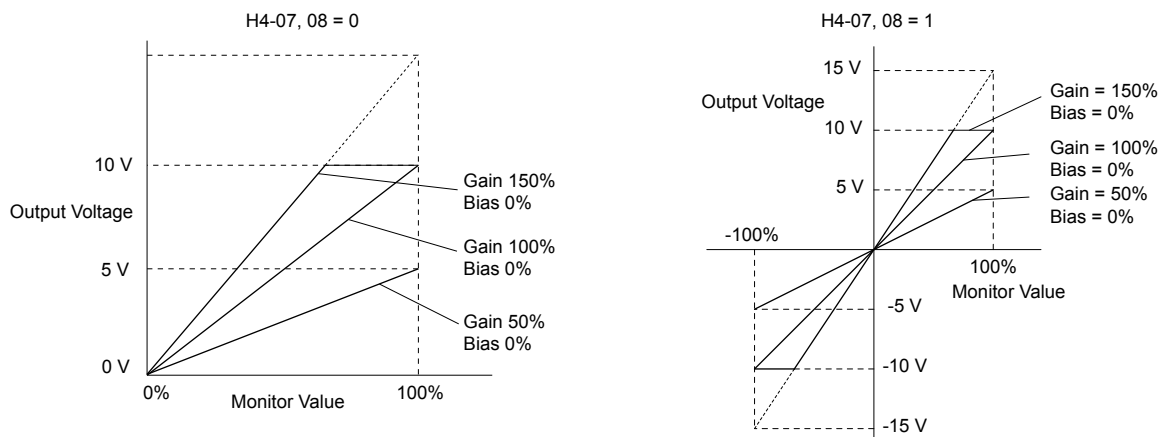

Figure 5.39 Analog Output Gain and Bias Setting Example 1 and 2

Example 3: Set H4-03 to 30% for an output signal of 3 V at terminal FM when the monitored value is at 0%.

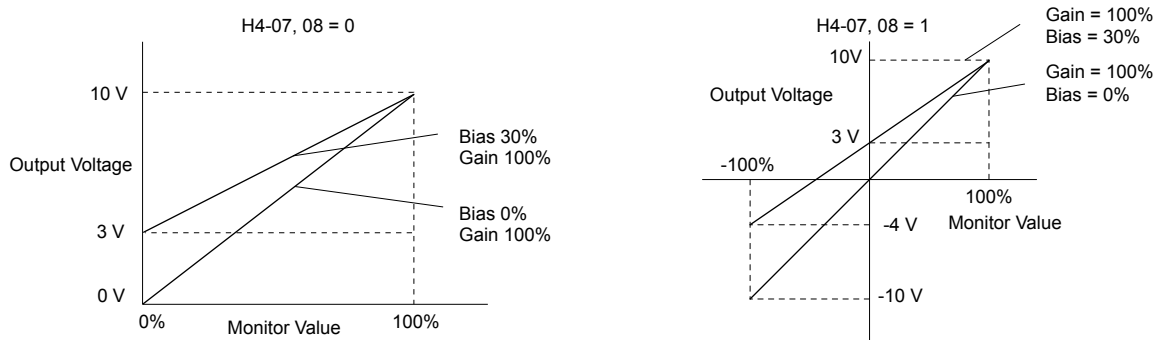

Figure 5.40 Analog Output Gain and Bias Setting Example 3

### ■ H4-07, H4-08: Multi-Function Analog Output Terminal FM, AM Signal Level Selection

Sets the voltage output level of U parameter (monitor parameter) data to terminal FM and terminal AM using parameters H4-07 and H4-08.

Set jumper S5 on the terminal board accordingly when changing these parameters.

No.	Name	Setting Range	Default
H4-07	Multi-Function Analog Output Terminal FM Signal Level Selection	0, 2	0
H4-08	Multi-Function Analog Output Terminal AM Signal Level Selection	0, 2	0

**Setting 0: 0 to 10 V**

**Setting 2: 4 to 20 mA**

## ◆ H5: MEMOBUS/Modbus Serial Communication

### ■ H5-04: Stopping Method after Communication Error

Selects the stopping method after the drive loses communication with the Z1000 Bypass and causes a communications error (CE).

- Note:**
1. Parameter H5-04 is only available in bypass controller software versions VST800297 and earlier.
  2. The function associated with this parameter is only used internally and is not related to customer serial communications.

No.	Name	Setting Range	Default
H5-04	Stopping Method after CE	0 to 4	3

#### Setting 0: Ramp to Stop

Uses the deceleration time currently enabled.

#### Setting 1: Coast to Stop

#### Setting 2: Fast Stop

#### Setting 3: Alarm Only - Operation Continues

#### Setting 4: Run at d1-04

## 5.9 L: Protection Functions

### ◆ L1: Motor Protection

#### ■ L1-01: Motor Overload Protection Selection

The drive has an electronic overload protection function that estimates the motor overload level based on output current, output frequency, thermal motor characteristics, and time. When the drive detects a motor overload an oL1 fault is triggered and the drive output shuts off.

L1-01 sets the overload protection function characteristics according to the motor being used.

No.	Name	Setting Range	Default
L1-01	Motor Overload Protection Selection	0, 1	1

- Note:**
1. When the motor protection function is enabled (L1-01 ≠ 0), an oL1 alarm can be output through one of the multi-function outputs by setting H2-01 to 1F<sup>1</sup>. The output closes when the motor overload level reaches 90% of the oL1 detection level.
  2. Set L1-01 to a value between 1 and 5 when running a single motor from the drive to select a method to protect the motor from overheat. An external thermal relay is not necessary.

<1> Details on this function can be found in the standard Z1000 Programming Manual (SIEPC71061645) at [www.yaskawa.com](http://www.yaskawa.com).

#### Setting 0: Disabled (Motor Overload Protection Is not Provided)

Use this setting if no motor overheat protection is desired or if multiple motors are connected to a single drive. If multiple motors are connected to a single drive, install a thermal relay for each motor as shown in [Figure 5.41](#).

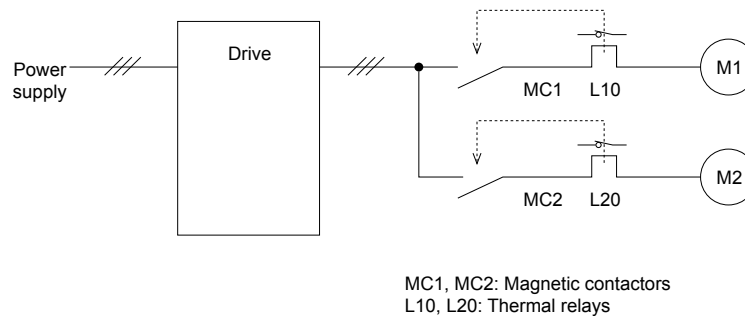

**Figure 5.41 Example of Protection Circuit Design for Multiple Motors**

**NOTICE:** Thermal protection cannot be provided when running multi-motors simultaneously with the same drive, or when using motors with a relatively high current rating compared to other standard motors (such as a submersible motor). Failure to comply could result in motor damage. Disable the electronic overload protection of the drive (L1-01 = "0: Disabled") and protect each motor with individual motor thermal overloads.

**Note:** Close MC1 and MC2 before operating the drive. MC1 and MC2 cannot be switched off during run.

#### Setting 1: General-Purpose Motor (Standard Self-Cooled)

Because the motor is self-cooled, the overload tolerance drops when the motor speed is lowered. The drive appropriately adjusts the electrothermal trigger point according to the motor overload characteristics, protecting the motor from overheat throughout the entire speed range.

Overload Tolerance	Cooling Ability	Overload Characteristics
<p>Rated Speed=100% Speed</p> <p>A: Max. speed for 200LJ and above B: Max. speed for 160MJ to 180 LJ C: Max. speed for 132MJ and below</p>	<p>Motor designed to operate from line power. Motor cooling is most effective when running at rated base frequency (check the motor nameplate or specifications).</p>	<p>Continuous operation at less than line power frequency with 100% load can trigger motor overload protection (oL1). A fault is output and the motor will coast to stop.</p>



## ■ L1-02: Motor Overload Protection Time

Sets the detection time of motor overheat due to overload. This setting rarely requires adjustment, but should correlate with the motor maximum load current protection time for performing a hot start.

No.	Name	Setting Range	Default
L1-02	Motor Overload Protection Time	0.1 to 50.0 minutes	1.0 minute

Defaulted to operate with an allowance of 150% overload operation for one minute in a hot start.

**Figure 5.42** illustrates an example of the electrothermal protection operation time using a general-purpose motor operating at the value of E1-06, Motor Base Speed, with L1-02 set to one minute.

During normal operation, motor overload protection operates in the area between a cold start and a hot start.

- Cold start: Motor protection operation time in response to an overload situation that was suddenly reached when starting a stationary motor.
- Hot start: Motor protection operation time in response to an overload situation that occurred during sustained operation at rated current.

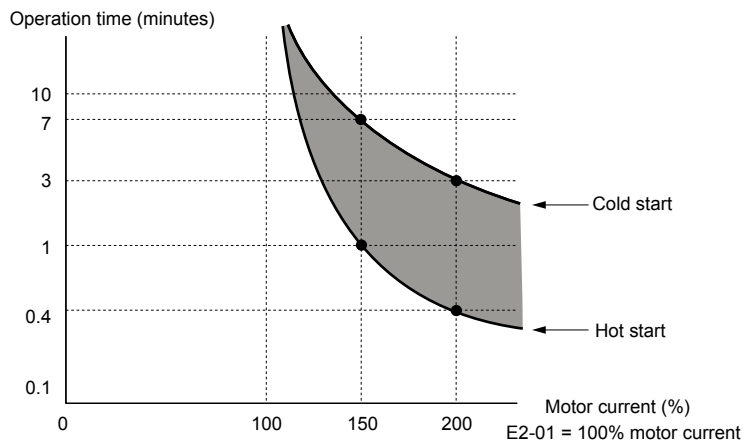

**Figure 5.42 Motor Protection Operation Time**

## ◆ L2: Momentary Power Loss Ride-Thru

### ■ L2-01: Momentary Power Loss Operation Selection

When a momentary power loss occurs (DC bus voltage falls below the level set in L2-05), the drive can automatically return to the operation it was performing prior to the power loss based on certain conditions.

**Note:** Default is 2 in bypass controller software versions VST800298 and later. Default is 0 in bypass controller software versions VST800297 and earlier.

No.	Name	Setting Range	Default
L2-01	Momentary Power Loss Operation Selection	0 to 2	2

#### Setting 0: Disabled

If power is not restored within 15 ms, a Uv1 fault will result and the motor coasts to stop.

#### Setting 1: Recover within L2-02

When a momentary power loss occurs, the drive output will be shut off. If the power returns within the time set to parameter L2-02, the drive will perform Speed Search and attempt to resume operation. If the power does not return within this time, it will trigger a Uv1 fault.

**Note:** L2-02 value is dependent on drive model selection and is not accessible.

#### Setting 2: Recover as long as CPU Has Power

When a momentary power loss occurs, the drive output will be shut off. If the power returns and the drive control circuit has power, the drive will attempt to perform Speed Search and resume the operation. This will not trigger a Uv1 fault.

#### Notes on Settings 1 and 2

“Uv” will flash on the operator while the drive is attempting to recover from a momentary power loss. A fault signal is not output at this time.

## 5.9 L: Protection Functions

### ■ L2-02: Momentary Power Loss Ride-Thru Time

Sets the maximum time allowed to ride through a power loss. If power loss operation exceeds this time, the drive will attempt to accelerate back to the frequency reference. This parameter is valid if L2-01 = 1.

**Note:** The amount of time the drive is capable of recovering after a power loss is determined by the capacity of the drive. Drive capacity determines the upper limit for L2-02.

No.	Name	Setting Range	Default
L2-02	Momentary Power Loss Ride-Thru Time	0.0 to 25.5 s	Determined by o2-04

### ■ L2-03: Momentary Power Loss Minimum Baseblock Time

Sets the minimum baseblock time when power is restored following a momentary power loss. This determines the time the drive waits for the residual voltage in the motor to dissipate. Increase this setting if overcurrent or overvoltage occurs at the beginning of Speed Search, after a power loss, or during DC Injection Braking.

No.	Name	Setting Range	Default
L2-03	Momentary Power Loss Minimum Baseblock Time	0.1 to 5.0 s	Determined by o2-04

### ■ L2-05: Undervoltage Detection Level (Uv)

Determines the voltage at which a Uv1 fault is triggered or at which the KEB function is activated. This setting rarely needs to be changed.

No.	Name	Setting Range	Default
L2-05	Undervoltage Detection Level	150 to 220 Vdc </>	Determined by E1-01 and o2-04

<1> Values are specific to 208 Vac. Double the value for 480 Vac.

- Note:**
1. Install an AC reactor option on the input side of the power supply when setting L2-05 below the default value to prevent damage to drive circuitry.
  2. If using KEB Ride-Thru and L2-05 is set too low, then undervoltage in the DC bus (Uv1) will be triggered before KEB Ride-Thru can be executed. Take caution not to set this value too low.

## ◆ L3: Stall Prevention

The motor may experience excessive slip because it cannot keep up with the frequency reference when the load is too high or acceleration and deceleration times are too short. If the motor slips during acceleration, it usually causes an overcurrent fault (oC), drive overload (oL2), or motor overload (oL1). If the motor slips during deceleration, it can cause excessive regenerative power to flow back into the DC bus capacitors, and eventually cause the drive to fault out from overvoltage (ov). The Stall Prevention Function prevents the motor from stalling and while allowing the motor to reach the desired speed without requiring the user to change the acceleration or deceleration time settings. The Stall Prevention function can be set separately for acceleration, operating at constant speeds, and deceleration.

### ■ L3-02: Stall Prevention Level during Acceleration

Sets the output current level at which the Stall Prevention during acceleration is activated.

No.	Name	Setting Range	Default
L3-02	Stall Prevention Level during Acceleration	0 to 150% </>	</>

<1> The upper limit and default values are determined by parameter L8-38, Carrier Frequency Derating Selection.

- Lower L3-02 if stalling occurs when using a motor that is relatively small compared to the drive.
- Also set parameter L3-03 when operating the motor in the constant power range.

### ■ L3-03: Stall Prevention Limit during Acceleration

The Stall Prevention level is automatically reduced when the motor is operated in the constant power range. L3-03 sets the lower limit for this reduction as a percentage of the drive rated current.

No.	Name	Setting Range	Default
L3-03	Stall Prevention Limit during Acceleration	0 to 100%	50%

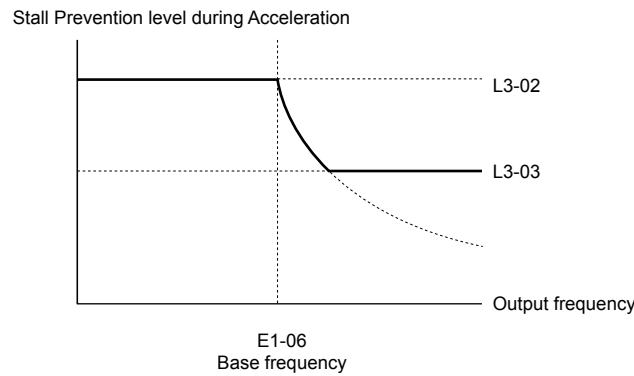

Figure 5.43 Stall Prevention Level and Limit During Acceleration

### ■ L3-04: Stall Prevention Selection during Deceleration

Stall Prevention during deceleration controls the deceleration based on the DC bus voltage and prevents an overvoltage fault caused by high inertia or rapid deceleration.

No.	Name	Setting Range	Default
L3-04	Stall Prevention Selection During Deceleration	0, 1, 2, 4, 5	1

#### Setting 0: Disabled

The drive decelerates according to the set deceleration time. With high inertia loads or rapid deceleration, an overvoltage fault may occur. If an overvoltage fault occurs, use dynamic braking options or switch to another L3-04 selection.

#### Setting 1: General-Purpose Stall Prevention

The drive tries to decelerate within the set deceleration time. The drive pauses deceleration when the DC bus voltage exceeds the Stall Prevention level and then continues deceleration when the DC bus voltage drops below that level. Stall Prevention may be triggered repeatedly to avoid an overvoltage fault. The DC bus voltage level for Stall Prevention depends on the input voltage setting E1-01.

Drive Input Voltage	Stall Prevention Level during Deceleration
208 Vac	377 Vdc
480 Vac	754 Vdc

**Note:** This method may lengthen the total deceleration time compared to the set value. If this is not appropriate for the application consider using a dynamic braking option.

Figure 5.44 illustrates the function of Stall Prevention during deceleration.

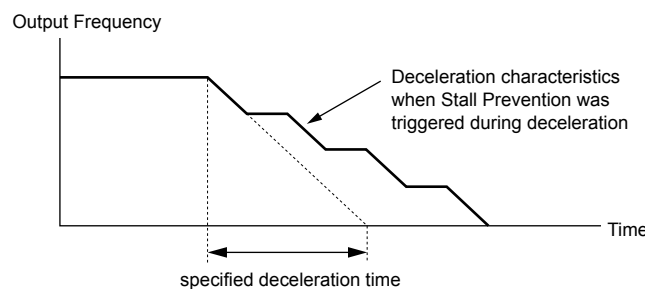

Figure 5.44 Stall Prevention During Deceleration

## 5.9 L: Protection Functions

### Setting 2: Intelligent Stall Prevention

The drive adjusts the deceleration rate so the DC bus voltage is kept at the level set to parameter L3-17<sup><I></sup>. This produces the shortest possible deceleration time while protecting the motor from stalling. The selected deceleration time is disregarded and the achievable deceleration time cannot be smaller than 1/10 of the set deceleration time.

This function uses the following parameters for adjusting the deceleration rate:

- DC bus voltage gain (L3-20<sup><I></sup>)
- Deceleration rate calculations gain (L3-21<sup><I></sup>)
- Inertia calculations for motor acceleration time (L3-24<sup><I></sup>)
- Load inertia ratio (L3-25)

<I> Details on this function can be found in the standard Z1000 Programming Manual (SIEPC71061645) at [www.yaskawa.com](http://www.yaskawa.com).

**Note:** The deceleration time is not constant. Do not use Intelligent Stall Prevention in applications where stopping accuracy is a concern.

### Setting 4: Overexcitation Deceleration 1

Overexcitation Deceleration 1 (increasing the motor flux) is faster than deceleration with no Stall Prevention (L3-04 = 0). Setting 4 changes the selected decel time and functions to provide protection from an overvoltage trip.

### Setting 5: Overexcitation Deceleration 2

Overexcitation Deceleration 2 slows down the motor while trying to maintain the DC bus voltage at the level set to parameter L3-17<sup><I></sup>. This function shortens the achievable deceleration time more than by using Overexcitation Deceleration 1. Setting 5 will shorten/lengthen the decel time to maintain the L3-17<sup><I></sup> bus level.

<I> Details on this function can be found in the standard Z1000 Programming Manual (SIEPC71061645) at [www.yaskawa.com](http://www.yaskawa.com).

## ■ L3-06: Stall Prevention Level during Run

Sets the current level to trigger Stall Prevention during run. Depending on the setting of parameter L3-23, the level is automatically reduced in the constant power range (speed beyond base speed).

The Stall Prevention level can be adjusted using an analog input. *Refer to Multi-Function Analog Input Terminal Settings on page 163* for details.

No.	Name	Setting Range	Default
L3-06	Stall Prevention Level During Run	30 to 150 <sup>&lt;I&gt;</sup>	<sup>&lt;I&gt;</sup>

<I> The upper limit and default values are determined by parameter L8-38, Carrier Frequency Derating Selection.

## ■ L3-11: Overvoltage Suppression Function Selection

Enables or disables the overvoltage suppression function.

No.	Name	Setting Range	Default
L3-11	Overvoltage Suppression Function Selection	0, 1	0

### Setting 0: Disabled

The regenerative torque limit and the output frequency are not adjusted. A regenerative load may trip the drive with an overvoltage fault. Use this setting if dynamic braking options are installed.

### Setting 1: Enabled

When the DC bus voltage rises due to regenerative load, an overvoltage fault is prevented by decreasing the regenerative torque limit and increasing the output frequency.

### ■ L3-25: Load Inertia Ratio

Determines the ratio between the rotor inertia and the load. Set this parameter when using Single Drive KEB 2 (L2-29 = 1<sup><1></sup>), Intelligent Stall Prevention during deceleration (L3-04 = 2), or the overvoltage suppression function (L3-11 = 1).

No.	Name	Setting Range	Default
L3-25	Load Inertia Ratio	0.0 to 1000.0	1.0

When set incorrectly, a fairly large current ripple can result during Single Drive KEB 2 (L2-29 = 1<sup><1></sup>). This may cause overvoltage suppression (L3-11 = 1) or other faults such as ov, Uv1, and oC.

Calculate parameter L3-25 in the formula below:

$$L3-25 = \frac{\text{Machine Inertia}}{\text{Motor Inertia}}$$

<1> Details on this function can be found in the standard Z1000 Programming Manual (SIEPC71061645) at [www.yaskawa.com](http://www.yaskawa.com).

### ◆ L4: Reference Detection

These parameters set up the Loss of Frequency Reference function.

#### ■ L4-05: Frequency Reference Loss Detection Selection

The drive can detect a loss of analog frequency reference from input A1 or A2. Frequency reference loss is detected when the frequency reference drops below 10% of the reference or below 5% of the maximum output frequency within 400 ms.

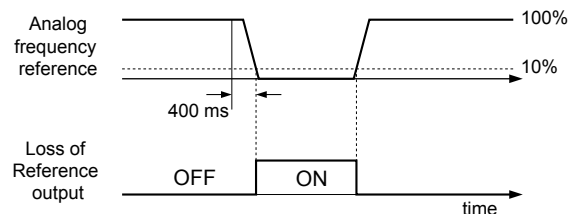

Figure 5.45 Loss of Reference Function

Parameter L4-05 selects the operation when a frequency reference loss is detected.

No.	Name	Setting Range	Default
L4-05	Frequency Reference Loss Detection Selection	0, 1	1

#### Setting 0: Stop

Drive follows the frequency reference (which is no longer present) and stops the motor.

#### Setting 1: Continue Operation with Reduced Frequency Reference

The drive will continue operation at the percent of the previous frequency value set to parameter L4-06. When the external frequency reference value is restored, the operation is continued with the frequency reference.

#### ■ L4-06: Frequency Reference at Reference Loss

Sets the frequency reference level at which the drive runs when L4-05 = 1 and when detecting a reference loss. The value is set as a percentage of the frequency reference before the loss was detected.

No.	Name	Setting Range	Default
L4-06	Frequency Reference at Reference Loss	0.0 to 100.0%	80.0%

### ◆ L5: Fault Restart

After a fault has occurred, Fault Restart attempts to automatically restart the motor and continue operation instead of stopping. The drive can perform a self-diagnostic check and resume the operation after a fault has occurred. If the self-check is successful and the cause of the fault has disappeared, the drive restarts by first performing Speed Search (*Refer to b3: Speed Search on page 122* for details).

- Note:**
1. The wiring sequence should remove the Forward/Reverse command when a fault is triggered and output is shut off.
  2. When the Forward/Reverse command is removed, the drive can perform a self-diagnostic check and attempt to restart the fault automatically.

**WARNING! Sudden Movement Hazard.** Do not use the fault restart function in lifting applications. Fault restart may cause the machine to drop the load, which could result in death or serious injury.

The drive can attempt to restart itself following the faults listed below.

Fault	Name
GF	Ground Fault
LF	Output Open Phase
oC	Overcurrent
oH1	Drive Overheat
oL1	Motor Overload
oL2	Drive Overload
oL3	Overtorque 1
oL4	Overtorque 2

Fault	Name
ov	DC Bus Overvoltage
PF	Input Phase Loss
rH	Braking Resistor Fault
rr	Braking Transistor Fault
Uv1	DC Bus Undervoltage <1>
STo	Pull-Out Detection

<1> When L2-01 is set to 0 through 2 (continue operation during momentary power loss).

Use parameters L5-01 to L5-05 to set up automatic fault restart.

Set H2-01, H2-02, or H2-03 to 1E. to output a signal during fault restart <1>.

<1> Details on this function can be found in the standard Z1000 Programming Manual (SIEPC71061645) at [www.yaskawa.com](http://www.yaskawa.com).

#### ■ L5-01: Number of Auto Restart Attempts

Sets the number of times that the drive may attempt to restart itself.

Parameter L5-05 determines the method of incrementing the restart counter. When the counter reaches the number set to L5-01, the operation stops and the fault must be manually cleared and reset.

The restart counter is incremented at each restart attempt, regardless of whether the attempt was successful. When the counter reaches the number set to L5-01, the operation stops and the fault must be manually cleared and reset.

The number of fault restarts is reset to zero when:

- The drive operates normally for 10 minutes following a fault restart.
- A fault is cleared manually after protective functions are triggered.
- The power supply is cycled.

No.	Name	Setting Range	Default
L5-01	Number of Auto Restart Attempts	0 to 10 Times	0 Times

#### ■ L5-02: Auto Restart Fault Output Operation Selection

Determines if a fault output is triggered (H2-□□ = E) when the drive attempts to restart.

No.	Name	Setting Range	Default
L5-02	Auto Restart Fault Output Operation Selection	0, 1	0

Setting 0: No Fault Output

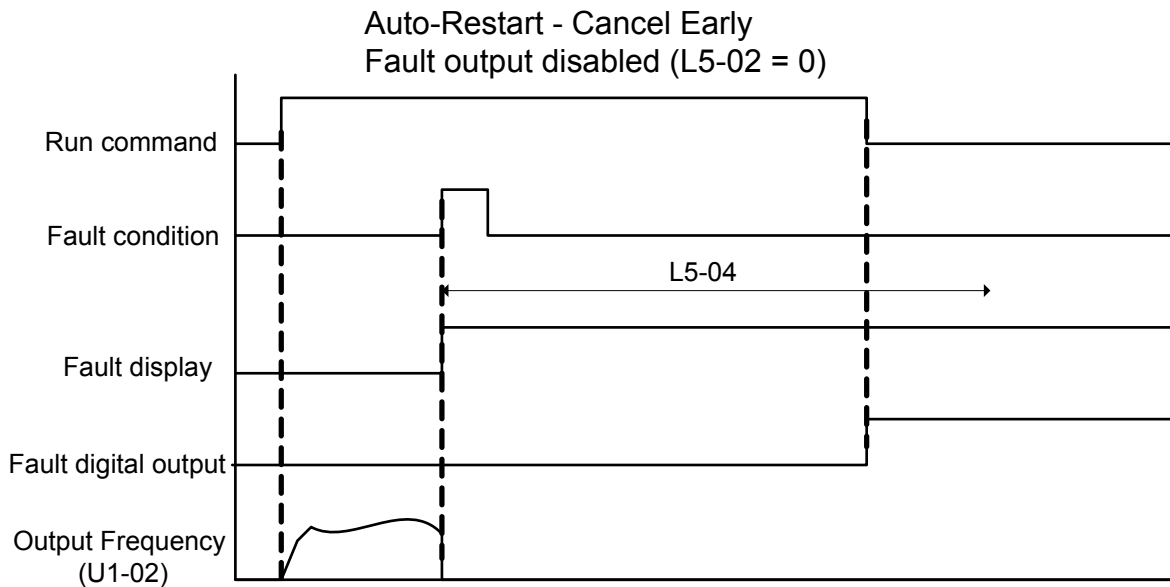

Figure 5.46 Auto Restart Cancel Early

Setting 1: Fault Output Is Set

■ L5-03: Time to Continue Making Fault Restarts (enabled only when L5-05 = 0)

Although the drive will continue to execute fault restarts, this parameter will cause a fault if a fault restart cannot occur after the time set to L5-03 passes.

All major faults will cause the drive to stop. For some faults it is possible to configure the drive to attempt a restart automatically. After the fault occurs, the drive baseblocks for L2-03 seconds. After the baseblock is removed, the drive checks if a fault condition still exists. If no fault condition exists, the drive will attempt to restart the motor. If the restart is successful, the drive performs a Speed Search (Regardless of the status of b3-01 "Speed Search Selection") from the set speed command and the Auto Restart Attempts count is increased by one. Even if the restart fails, the restart count is increased by one as long as the drive attempted to rotate the motor. The restart count will not be incremented if the restart is not attempted due to a continuing fault condition, (i.e., an ov fault). The drive waits L5-03 seconds before attempting another restart.

No.	Name	Setting Range	Default
L5-03	Time to Continue Making Fault Restarts	0.00 to 600.0 s	180.0 s

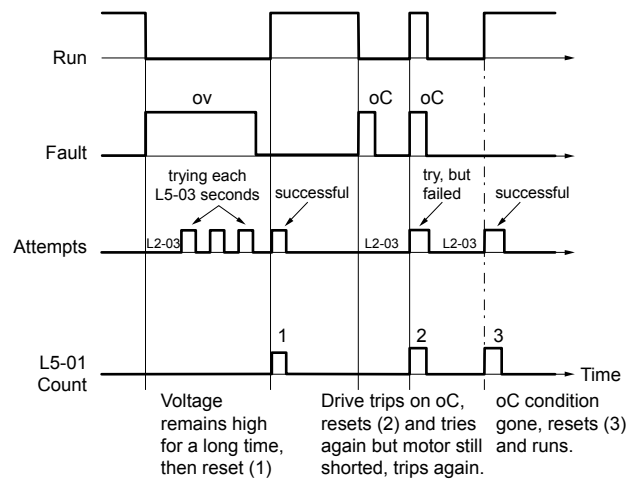

Figure 5.47 Automatic Restart Timing Diagram

The auto restart count is reset back to 0 if any of the following occur:

- No further faults for 10 minutes after the last retry.
- The drive power is turned off (the drive must be without power long enough to let control power dissipate).

## 5.9 L: Protection Functions

- The RESET key is pushed after the last reset attempt.

The setting of parameter L5-02 determines whether the fault output (MA-MB) will be closed during an auto restart attempt.

The setting of L5-02 can be important when using the drive with other equipment.

The following faults will allow the Auto Restart function to initiate:

- oC (Overcurrent)
- LF (Output Phase Loss)
- PF (Input Phase Loss)
- oL1 (Motor Overload)
- oL3 (Overtorque Detection 1)
- oL2 (Drive Overload)
- ov (Overvoltage)
- GF (Ground Fault)
- Uv1 (Undervoltage)
- oH1 (Heatsink Overheat)

In order for auto restart after a Uv1 fault, Momentary Power Loss Ride-thru must be enabled (L2-01= 1: “Power Loss Ridethru Time”). Setting H2-01, H2-02 or H2-03 to 1E configures a digital output as “Restart Enabled” to signal if an impending auto restart is possible <1>.

<1> Details on this function can be found in the standard Z1000 Programming Manual (SIEPC71061645) at [www.yaskawa.com](http://www.yaskawa.com).

### ■ L5-04: Fault Reset Interval Time

Determines the amount of time to wait between restart attempts when parameter L5-05 is set to 1.

No.	Name	Setting Range	Default
L5-04	Fault Reset Interval Time	0.5 to 600.0 s	10.0 s

### ■ L5-05: Fault Reset Operation Selection

No.	Name	Setting Range	Default
L5-05	Fault Reset Operation Selection	0, 1	1

#### Setting 0: Count Successful Restarts

The drive will continuously attempt to restart. If it restarts successfully, the restart counter is increased. This operation is repeated each time a fault occurs until the counter reaches the value set to L5-01.

#### Setting 1: Count Restart Attempts

The drive will attempt to restart using the time interval set to parameter L5-04. A record is kept of the number of attempts to restart to the drive, regardless of whether those attempts were successful. When the number of attempted restarts exceeds the value set to L5-01, the drive stops attempting to restart.

## ◆ L6: Torque Detection

The drive provides two independent torque detection functions that trigger an alarm or fault signal when the load is too heavy (oL), or suddenly drops (UL). These functions are set up using the L6-□□ parameters. Program the digital outputs as shown below to indicate the underload or overload condition to an external device:

**Note:** When overtorque occurs in the application, the drive may stop due to overcurrent (oC) or overload (oL1). To prevent the drive from stopping, use torque detection to indicate an overload situation to the controller before oC or oL1 occur. Use undertorque detection to discover application problems like a torn belt, a pump shutting off, or other similar trouble.

H2-01, H2-02, H2-03 Setting <1> <2>	Description
B	Torque detection 1, N.O. (output closes when overload or underload is detected)
17	Torque detection 1, N.C. (output opens when overload or underload is detected)

<1> Parameters H2-01, H2-02, and H2-03 are available in bypass controller software versions VST800298 and later.

<2> Details on this function can be found in the standard Z1000 Programming Manual (SIEPC71061645) at [www.yaskawa.com](http://www.yaskawa.com).

*Figure 5.48* and *Figure 5.49* illustrate the functions of overtorque and undertorque detection.



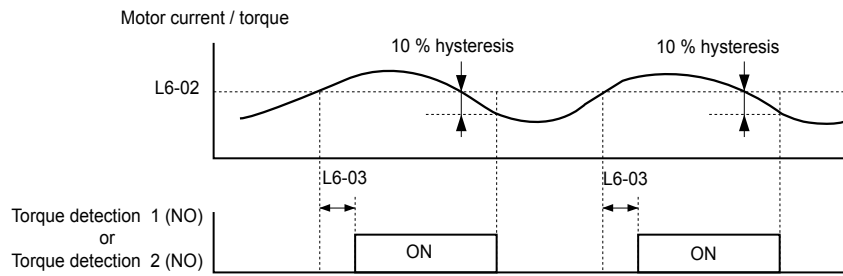

Figure 5.48 Overtorque Detection Operation

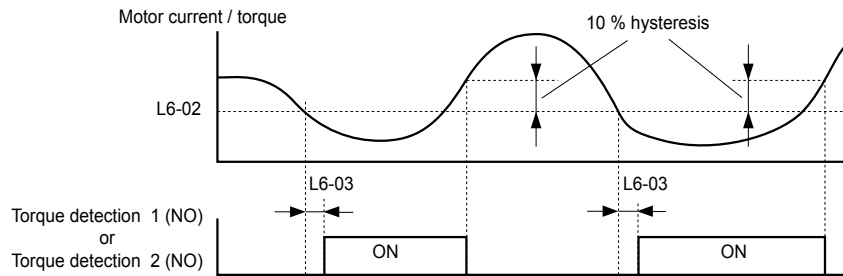

Figure 5.49 Undertorque Detection Operation

- Note:**
1. The torque detection function uses a hysteresis of 10% of the drive rated output current and motor rated torque.
  2. The level is set as a percentage of the drive rated output current.

### ■ L6-01: Torque Detection Selection 1

The torque detection function is triggered when the current or torque exceed the levels set to L6-02 for longer than the time set to L6-03. L6-01 selects the conditions for detection and the operation that follows.

**Note:** Parameter is available in bypass controller software versions VST800298 and later.

No.	Name	Setting Range	Default
L6-01	Torque Detection Selection 1	0 to 8	0

#### Setting 0: Disabled

#### Setting 1: oL3 at Speed Agree (Alarm)

Overtorque detection is active only when the output speed is equal to the frequency reference (i.e., no detection during acceleration and deceleration). The operation continues after detecting overtorque and triggering an oL3 alarm.

#### Setting 2: oL3 at Run (Alarm)

Overtorque detection works as long as the Run command is active. The operation continues after detecting overtorque and triggering an oL3 alarm.

#### Setting 3: oL3 at Speed Agree (Fault)

Overtorque detection is active only when the output speed is equal to the frequency reference (i.e., no detection during acceleration and deceleration). The operation stops and triggers an oL3 fault.

#### Setting 4: oL3 at Run (Fault)

Overtorque detection works as long as a Run command is active. The operation stops and triggers an oL3 fault.

#### Setting 5: UL3 at Speed Agree (Alarm)

Undertorque detection is active only when the output speed is equal to the frequency reference (i.e., no detection during acceleration and deceleration). The operation continues after detecting overtorque and triggering a UL3 alarm.

#### Setting 6: UL3 at Run (Alarm)

Undertorque detection works as long as the Run command is active. The operation continues after detecting overtorque and triggering a UL3 alarm.

## 5.9 L: Protection Functions

### Setting 7: UL3 at Speed Agree (Fault)

Undertorque detection is active only when the output speed is equal to the frequency reference (i.e., no detection during acceleration and deceleration). The operation stops and triggers a UL3 fault.

### Setting 8: UL3 at Run (Fault)

Undertorque detection works as long as a Run command is active. The operation stops and triggers a UL3 fault.

### ■ L6-02: Torque Detection Level 1

Sets the detection levels for torque detection function 1 as a percentage of the drive rated output current.

No.	Name	Setting Range	Default
L6-02	Torque Detection Level 1	0 to 300%	15%

**Note:** The torque detection level 1 (L6-02) can also be supplied by an analog input terminal set to H3-□□ = 7. Here, the analog value has priority and the setting in L6-02 is disregarded.

### ■ L6-03: Torque Detection Time 1

Determines the time required to trigger an alarm or fault after exceeding the level in L6-02.

No.	Name	Setting Range	Default
L6-03	Torque Detection Time 1	0.0 to 10.0 s	10.0 s

### ■ L6-13: Motor Underload Protection Selection

Sets Motor Underload Protection (UL6) based on motor load and determines whether the level of L6-02 refers to fbase or fmax.

Selects the operation of underload detection UL6. Underload is detected when the output current falls below the underload detection level defined by L6-14 and L2-02<sup><1></sup>.

<1> Details on this function can be found in the standard Z1000 Programming Manual (SIEPC71061645) at [www.yaskawa.com](http://www.yaskawa.com).

No.	Name	Setting Range	Default
L6-13	Motor Underload Protection Selection	0, 1	0

### Setting 0: Fbase Motor Load Enabled

### Setting 1: Fmax Base Motor Load Enabled

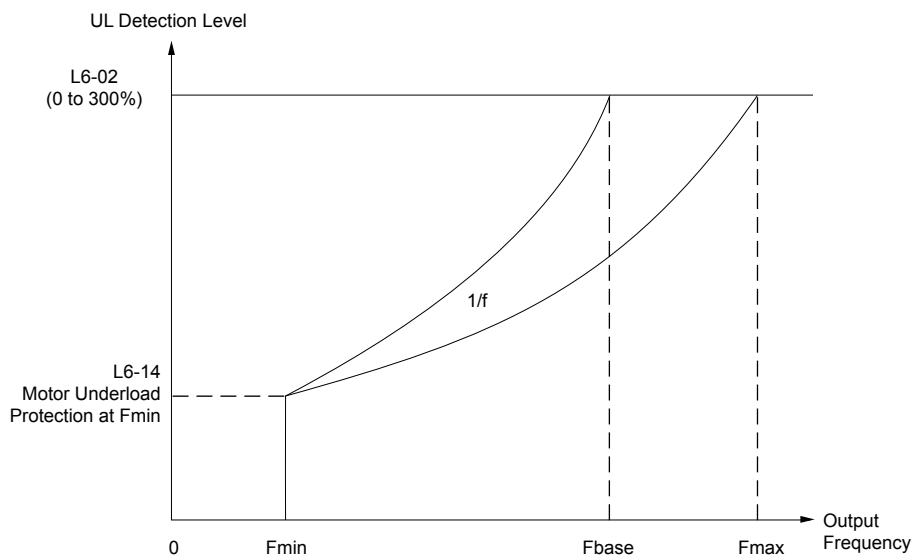

Figure 5.50 Motor Underload Protection

### ■ L6-14: Motor Underload Protection Level at Minimum Frequency

Sets the UL6 detection level at minimum frequency by percentage of drive rated current

No.	Name	Setting Range	Default
L6-14	Motor Underload Protection Level at Minimum Frequency	0 to 300%	15%

## ◆ L8: Drive Protection

### ■ L8-02: Overheat Alarm Level

Sets the overheat alarm (oH) detection level.

The drive outputs an alarm when the heatsink temperature exceeds the overheat alarm level. If the drive is set to continue operation after this alarm occurs (L8-03 = 4<sup><I></sup>) and the temperature reaches the overheat fault level, the drive will trigger an oH1 fault and stop operation.

<1> Details on this function can be found in the standard Z1000 Programming Manual (SIEPC71061645) at [www.yaskawa.com](http://www.yaskawa.com).

When an output terminal is set for the oH pre-alarm (H2-□□ = 20), the switch will close when the heatsink temperature rises above L8-02.

No.	Name	Setting Range	Default
L8-02	Overheat Alarm Level	50 to 130 °C	Determined by o2-04

### ■ L8-05: Input Phase Loss Protection Selection

Enables or disables the input phase loss detection.

No.	Name	Setting Range	Default
L8-05	Input Phase Loss Protection Selection	0, 1	1

**Setting 0: Disabled**

**Setting 1: Enabled**

Enables input phase loss detection. Since measuring the DC bus ripple detects input phase loss, a power supply voltage imbalance or main circuit capacitor deterioration may also trigger a phase loss fault (PF).

Detection is disabled if:

- The drive is decelerating.
- No Run command is active.
- Output current is less than or equal to 30% of the drive rated current.

### ■ L8-06: Input Phase Loss Detection Level

Sets the Input Phase Loss Detection (PF) Level.

Triggers PF fault when there is an imbalance larger than the value set to L8-06 in the drive input power voltage.

Detection Level = 100% = Voltage Class ×  $\sqrt{2}$

No.	Name	Setting Range	Default
L8-06	Input Phase Loss Detection Level	0.0 to 50.0%	Determined by o2-04

### ■ L8-07: Output Phase Loss Protection Selection

Enables or disables the output phase loss detection triggered when the output current falls below 5% of the drive rated current.

**Note:** Output phase loss detection can mistakenly be triggered if the motor rated current is very small compared to the drive rating. Disable this parameter in such cases.

No.	Name	Setting Range	Default
L8-07	Output Phase Loss Protection Selection	0 to 2	1

**Setting 0: Disabled**

**Setting 1: Fault when One Phase Is Lost**

An output phase loss fault (LF) is triggered when one output phase is lost. The output shuts off and the motor coasts to stop.

## 5.9 L: Protection Functions

### Setting 2: Fault when Two Phases Are Lost

An output phase loss fault (LF) is triggered when two or more output phases are lost. The output shuts off and the motor coasts to stop.

#### ■ L8-09: Output Ground Fault Detection Selection

Enables or disables the output ground fault detection.

No.	Name	Setting Range	Default
L8-09	Output Ground Fault Detection Selection	0, 1	Determined by o2-04

#### Setting 0: Disabled

Ground faults are not detected.

#### Setting 1: Enabled

A ground fault (GF) is triggered when high leakage current or a ground short circuit occurs in one or two output phases.

#### ■ L8-38: Carrier Frequency Reduction Selection

Selects the operation of the carrier frequency reduction function. Reduces the carrier frequency when the output current exceeds a certain level. This temporarily increases the overload capability (oL2 detection), allowing the drive to run through transient load peaks without tripping.

No.	Name	Setting Range	Default
L8-38	Carrier Frequency Reduction Selection	0 to 2	Determined by o2-04

#### Setting 0: Disabled

No carrier frequency reduction at high current.

#### Setting 1: Enabled for Output Frequencies below 6 Hz

The carrier frequency is reduced at speeds below 6 Hz when the current exceeds 100% of the drive rated current. The drive returns to the normal carrier frequency when the current falls below 88% or the output frequency exceeds 7 Hz.

#### Setting 2: Enabled for Entire Frequency Range

The carrier frequency is reduced at the following speeds:

- Below 6 Hz when the current exceeds 100% of the drive rated current.
- Above 7 Hz when the current exceeds 112% of the drive rated current.

The drive uses the delay time set in parameter L8-40<sup><1></sup> and a hysteresis of 12% when switching the carrier frequency back to the set value.

<1> Details on this function can be found in the standard Z1000 Programming Manual (SIEPC71061645) at [www.yaskawa.com](http://www.yaskawa.com).

## 5.10 n: Special Adjustments

These parameters control a variety of specialized adjustments and functions, including Hunting Prevention and High Slip Braking.

### ◆ n1: Hunting Prevention

Hunting Prevention prevents the drive from hunting as a result of low inertia and operating with light load. Hunting often occurs with a high carrier frequency and an output frequency below 30 Hz.

#### ■ n1-01: Hunting Prevention Selection

Enables or disables the Hunting Prevention function.

**Note:** This function is available only when using V/f Control. Disable Hunting Prevention when drive response is more important than suppressing motor oscillation. This function may be disabled without problems in applications with high inertia loads or relatively heavy loads.

No.	Name	Setting Range	Default
n1-01	Hunting Prevention Selection	0, 1	1

**Setting 0: Disabled**

**Setting 1: Enabled**

#### ■ n1-02: Hunting Prevention Gain Setting

Sets the gain for the Hunting Prevention Function.

No.	Name	Setting Range	Default
n1-02	Hunting Prevention Gain Setting	0.00 to 2.50	1.00

Although this parameter rarely needs to be changed, it may require adjustment in the following situations:

- If the motor vibrates while lightly loaded and n1-01 = 1, increase the gain by 0.1 until vibration ceases.
- If the motor stalls while n1-01 = 1, decrease the gain by 0.1 until the stalling ceases.

### ◆ n3: High Slip Braking (HSB) and Overexcitation Braking

#### ■ High Slip Braking (V/f)

HSB works in V/f Control only and decreases the stopping time compared to normal deceleration without using dynamic braking options. HSB reduces the output frequency in large steps to stop the motor and produce a high slip, which dissipates the regenerative energy created from decelerating the load in the motor windings. Due to the increased temperature of the motor windings, do not use HSB to frequently stop the motor. The duty cycle should be around 5% or lower.

#### Notes on Using High Slip Braking

- The set deceleration time is ignored during HSB. Use Overexcitation Deceleration 1 (L3-04 = 4) to stop the motor within a specified time.
- Braking time varies based on the load inertia and motor characteristics.
- Enabling HSB and KEB Ride-Through simultaneously will trigger an oPE03 error.
- HSB must be triggered by a digital input set to H1-□□ = 68. After the HSB command is given, the drive will not restart until the motor is completely stopped and the Run command is cycled.
- Use parameters n3-01 through n3-04 to adjust HSB.

#### ■ n3-04: High Slip Braking Overload Time

Sets the time required for an HSB overload fault (oL7) to occur when the drive output frequency does not change during an HSB stop due to excessive load inertia or the load rotating the motor. To protect the motor from overheat, the drive trips with an oL7 fault if these conditions last longer than the time set in n3-04.

No.	Name	Setting Range	Default
n3-04	High Slip Braking Overload Time	30 to 1200 s	40 s

## 5.10 n: Special Adjustments

---

### ■ n3-13: Overexcitation Deceleration Gain

Multiplies a gain to the V/f pattern output value during Overexcitation Deceleration to determine the level of overexcitation. The drive returns to the normal V/f value after the motor has stopped or when it is accelerating to the frequency reference.

No.	Name	Setting Range	Default
n3-13	Overexcitation Deceleration Gain	1.00 to 1.40	1.10

The optimum setting for n3-13 depends on the motor flux saturation characteristics.

- Gradually increase the gain to 1.25 or 1.30 to improve the braking power of Overexcitation Deceleration.
- Lower n3-13 when flux saturation characteristics cause overcurrent. A high setting sometimes causes overcurrent (oC), motor overload (oL1), or drive overload (oL2). Lowering n3-21 can also help remedy these problems.

## 5.11 o: Operator-Related Settings

These parameters control the various functions, features, and display of the HOA keypad.

### ◆ o1: HOA Keypad Display Selection

These parameters determine the data display on the HOA keypad.

#### ■ o1-01: Drive Mode Unit Monitor Selection

The frequency reference display appears when the drive is powered up. Pressing the up arrow key will display the following data: frequency reference → rotational direction → output frequency → output current → o1-01 selection.

Parameter o1-01 selects the content of the last monitor in this sequence.

No.	Name	Setting Range	Default
o1-01	Drive Mode Unit Monitor Selection	104 to 699 U1-04 (Control Mode) to U6-99 (Option Monitors 20) </>	106 (U1-06)

<1> U2-□□ and U3-□□ parameters cannot be selected.

**Note:** Available for bypass control software versions VST800401 and later.

#### ■ o1-02: User Monitor Selection after Power Up

Selects which monitor parameter is displayed upon power up by entering the 1- □□ part of U1-□□. Certain monitors are not available in some control modes. [Refer to U: Monitor Parameters on page 195](#) for a list of monitors.

No.	Name	Setting Range	Default
o1-02	User Monitor Selection after Power Up	1 to 5	1

#### Setting 1: Frequency Reference (U1-01)

#### Setting 2: Motor Direction

#### Setting 3: Output Frequency (U1-02)

#### Setting 4: Output Current (U1-03)

#### Setting 5: User Monitor

The monitor value selected by o1-01 will be displayed.

**Note:** Available for bypass control software versions VST800401 and later.

#### ■ o1-03: HOA Keypad Display Selection

Sets the units used to display the frequency reference and output frequency. Set o1-03 to 3 for user-set units before setting parameters o1-10 and o1-11.

No.	Name	Setting Range	Default
o1-03	HOA Keypad Display Selection	0 to 3	0

#### Setting 0: 0.01 Hz Units

#### Setting 1: 0.01% Units (100% = Max Output Frequency)

#### Setting 2: r/min Units (Calculated by the Max Output Frequency and the Number of Motor Poles)

#### Setting 3: User-set Units (Use o1-10, o1-11)

Set the value used for the maximum frequency reference to o1-10. Set the placement of the decimal point in this number to o1-11.

For example, to have the maximum output frequency displayed as “100.00”, set o1-10 = 1000 and o1-11 = 2 (i.e., 1000 with 2 decimal points).

- Note:**
- Parameter o1-03 allows the programmer to change the units used in the following parameters and monitors:  
U1-01: frequency reference  
U1-02: output frequency  
U1-16: output frequency after softstarter (accel/decel ramp generator)  
d1-01 to d1-17: frequency references
  - Setting o1-03 to 2 requires entering the number of motor poles to E2-04 and E5-04.

## 5.11 o: Operator-Related Settings

---

### ■ o1-09: Frequency Reference Display Units

Sets unit display for the frequency reference parameters and frequency related monitors when o1-03 = 3.

No.	Name	Setting Range	Default
o1-09	Frequency Reference Display Units	0 to 16	16

**Setting 0: Inch of Water (“WC)**

**Setting 1: Pounds per Square Inch (PSI)**

**Setting 2: Gallons per Minute (GPM)**

**Setting 3: Degrees Fahrenheit (F)**

**Setting 4: Cubic Feet per Minute (CFM)**

**Setting 5: Cubic Meters per Hour (CMH)**

**Setting 6: Liters per Hour (LPH)**

**Setting 7: Liters per Second (LPS)**

**Setting 8: Bar (Bar)**

**Setting 9: Pascals (Pa)**

**Setting 10: Degrees Celsius (C)**

**Setting 11: Meters (Mtr)**

**Setting 12: Ft (Feet)**

**Setting 13: Liters per Minute (LPM)**

**Setting 14: Cubic Meters per Minute (CMM) No unit**

**Setting 15: Custom Units (Determined by o1-12)**

**Setting 16: None**



### ■ o1-10: User-Set Display Units Maximum Value

Determines the display value that is equal to the maximum output frequency.

No.	Name	Setting Range	Default
o1-10	User-Set Display Units Maximum Value	1 to 60000	Determined by o1-03

### ■ o1-11: User-Set Display Units Decimal Display

Determines how many decimal points should be used to set and display the frequency reference.

No.	Name	Setting Range	Default
o1-11	User-Set Display Units Decimal Display	0 to 3	Determined by o1-03

**Setting 0: No Decimal Point**

**Setting 1: One Decimal Point**

**Setting 2: Two Decimal Points**

**Setting 3: Three Decimal Points**

## ◆ o2: HOA Keypad Functions

These parameters determine the functions assigned to the operator keys.

### ■ o2-04: Drive Model Selection

Set this parameter when replacing the control board or the terminal board. *Refer to Defaults by Drive Model on page 372* for information on drive model selection.

**NOTICE:** Drive performance will suffer and protective functions will not operate properly if the correct drive capacity is not set to o2-04.

No.	Name	Setting Range	Default
o2-04	Drive Model Selection	-	Determined by drive capacity

**Note:** Change o2-04 setting only when necessary.

## ◆ o4: Maintenance Monitor Settings

### ■ o4-03: Cooling Fan Operation Time Setting

Sets the value for how long the cooling fan has been operating. This value can be viewed in monitor U4-03. Parameter o4-03 also sets the base value used for the cooling fan maintenance, which is displayed in U4-04. Reset this parameter to 0 after replacing the cooling fan.

- Note:**
1. The value in o4-03 increases after every 10 hours of use. A setting of 30 will set the cooling fan operation time counter to 300 h. "300" will be displayed in monitor U4-03.
  2. The cooling fan may require maintenance at an earlier date in harsher environments.

No.	Name	Setting Range	Default
o4-03	Cooling Fan Operation Time Setting	0 to 9999 h	0 h

### ■ o4-11: U2-□□, U3-□□, and UB-09 to UB-16 Initialization

Resets the drive and bypass fault trace and fault history monitors.

- Note:**
1. Parameter is available in bypass controller software versions VST800298 and later.
  2. Initializing the drive using A1-03 does not reset these monitors.

No.	Name	Setting Range	Default
o4-11	U2, U3, and UB-09 to UB-16 Initialization	0, 1	0

**Setting 0: No Action**

The drive and bypass keep the previously saved record concerning fault trace and fault history.

## 5.11 o: Operator-Related Settings

---

### Setting 1: Reset Fault Data

Resets the data for the U2-□□, U3-□□, and UB-09 to UB-16 monitors. Setting o4-11 to 1 and pressing the ENTER key erases fault data in the bypass and drive and returns the display to 0.

## 5.12 S: Special Parameters

### ◆ S1: Dynamic Audible Noise Control Function

The Dynamic Audible Noise Control Function reduces audible noise by suppressing the output voltage.

This function is available when using V/f Control mode and can help to quickly restore output voltage after an impact has caused a sudden increase in the time constant. Dynamic Audible Noise Control is useful in applications where load impact is common.

#### Procedure

1. Set S1-01 to 1 to enable Dynamic Audible Noise Control.

**Note:** 1. When S1-01 is set to 1, the tolerance to impact loading is reduced when compared to V/f Control (without Energy Saving).

2. Disable Dynamic Audible Noise Control for applications without an impact load.

2. Responsiveness is increased because the addition of a load causes the level of the current to rise.

Increase the value of S1-02. The flux will become stronger and the torque will rise, but load movement will be minimized by the Dynamic Audible Noise Control function.

Set S1-03 and S1-04 to a small value. Voltage is recovered quicker during impact load conditions. Under certain conditions voltage stability may become poor.

Lower the value of S1-05. The voltage level will drop and speed up voltage restoration when the load is increased.

3. Increase the value of S1-03 to increase the effectiveness of Dynamic Audible Noise Control if the output voltage remains high.

4. Decrease the value of S1-06 to increase drive response to an impact load.

5. When the output voltage is unstable, increase the difference between S1-03 and S1-04 and increase S1-05 and S1-06 to slow the load response.

### ■ S1-01: Dynamic Audible Noise Control Selection

Reduces audible noise by decreasing the output voltage in variable torque applications with light loads.

No.	Name	Setting Range	Default
S1-01	Dynamic Audible Noise Control Selection	0 or 1	1

**Setting 0: Disabled**

**Setting 1: Enabled**

### ■ S1-02: Voltage Reduction Rate

Sets the rate at which the output voltage will be reduced as a percentage of the V/f pattern when operating with no load.

No.	Name	Setting Range	Default
S1-02	Voltage Reduction Rate	50.0 to 100.0%	50.0%

### ■ S1-03: Voltage Restoration Level

Sets the level when the drive should start restoring the voltage as a percentage of the drive rated torque.

The voltage is reduced when the torque output has decreased to the level set in S1-03.

The method used to reduce the voltage level is selected in accordance with the characteristics of the voltage reduction rate defined by the S1-03 and S1-04 settings.

**Note:** Setting S1-04 to a value less than that of S1-03 + 10.0 will trigger an oPE02 error.

No.	Name	Setting Range	Default
S1-03	Voltage Restoration Level	0.0 to 90.0%	20.0%

## 5.12 S: Special Parameters

### ■ S1-04: Voltage Restoration Complete Level

Sets the level at which voltage restoration for the V/f pattern is complete as a percentage of the drive rated torque. If the output torque rises above the value of S1-04, then the voltage will be controlled in a manner specified by the V/f pattern setting.

**Note:** Setting S1-04 to a value less than that of S1-03 + 10.0 will trigger an oPE02 error.

No.	Name	Setting Range	Default
S1-04	Voltage Restoration Complete Level	S1-03 + 10.0 to 100.0%	50.0%

### ■ S1-05: Voltage Restoration Sensitivity Time Constant

Sets the level of sensitivity of the output torque as well as that of the LPF time constant for the voltage reduction rate. The level of sensitivity can be adjusted in accordance with the load response.

The LPF time constant is used to calculate the value of the output torque sensitivity time constant.

The voltage reduction rate is based on the torque output. Select LPF to prevent voltage fluctuation.

The Dynamic Audible Noise Control Function outputs the rate of voltage reduction as a percentage within the allowable range (Max: 100%, Min: S1-02 value).

No.	Name	Setting Range	Default
S1-05	Voltage Restoration Sensitivity Time Constant	0.000 to 3.000 s	1.000 s

### ■ S1-06: Voltage Restoration Time Constant at Impact

Sets the voltage restoration time constant if an impact load is added.

Sets the time constant that enables the voltage level to rise if the speed suddenly changes upon impact.

No.	Name	Setting Range	Default
S1-06	Voltage Restoration Time Constant at Impact	0.000 to 1.000 s	0.050 s

## ◆ S2: Sequence Timers

### ■ Programmable Run Timers for Real Time Clock (RTC)

Programmable run timers allow the drive to start and stop automatically at specified times. The timers can be configured to run daily, on weekdays, on weekends, or only on specific days of the week.

#### Sequence Timer 1

When the current time reaches the value set in parameter S2-01 (Sequence Timer 1 Start Time), the drive will execute the action set in parameter S2-04 (Sequence Timer 1 Selection), provided the current day is selected via S2-03 (Sequence Timer 1 Day Selection). The drive will stop executing the S2-04 action when the S2-02 (Sequence Timer 1 Stop Time) is reached.

When S2-04 = 0 or the Disable Sequence Timers multi-function input (H1-□□ = 50) is closed, Sequence Timer 1 has no effect on the drive Run command. The drive runs normally based on the status of the selected run source (b1-02). If S2-04 = 1 or 2 and the Disable Sequence Timers input is open, the drive will run during the Sequence Timer 1 active time, provided the drive has a valid Run command. The frequency reference that is used is set by S2-05 (Sequence Timer 1 Reference Source). When S2-04 = 2, PI control is disabled.

If the Cancel Active Sequence Timer multi-function input (H1-□□ = 51) transitions from open to closed while Sequence Timer 1 is active, the timer will be disabled until the next scheduled sequence timer occurrence. Sequence Timer 1 can be re-enabled by cycling the drive Run command. The Sequence Timer 1 multi-function output (H2-□□ = 50<sup><1></sup>) will close while Sequence Timer 1 is active regardless of the S2-04 selection.

When S2-01 = S2-02, Sequence Timer 1 is active continuously for the days selected in S2-03. The timer will start at the S2-01/S2-02 time on the first day and stop at the same time on the last day. If only one day is selected in S2-03, the timer will stop at 24:00 on that day.

When S2-04 = 1 or 2, Sequence Timer 1 is active and the drive is running, the HOA Keypad will display “Sequence Timer 1 RUN”. When the drive has a run command, S2-04 = 1 or 2 and Sequence Timer 1 is not active, the HOA Keypad will display “Sequence Timer OFF”.

When the drive has a run command, S2-04 = 1 or 2 and Sequence Timer 1 is not active, the drive should not fault on undervoltage or overvoltage conditions (should be Alarm only).

<1> Details on this function can be found in the standard Z1000 Programming Manual (SIEPC71061645) at [www.yaskawa.com](http://www.yaskawa.com).

**Sequence Timers 2 to 4**

These timers operate identically to Sequence Timer 1. Parameters S2-06 to S2-20 configure Sequence Timers 2 to 4.

**Priority**

If multiple sequence timers overlap, the timer with the lowest number has priority.

Sequence Timer 1 = highest priority

Sequence Timer 4 = lowest priority

**■ S2-01/S2-06/S2-11/S2-16: Sequence Timers 1 to 4 Start Time**

Sets the start times for timers 1 to 4.

If the Stop Time is set to a higher value than the Start Time, the Sequence Timers will be active starting from the set Start Time, run through midnight, and stop the following day at the set Stop Time.

**Note:** Setting the sequence timer start time to a higher value than the sequence timer stop time disables that sequence timer in drive software versions PRG: 8551 and earlier.

No.	Name	Setting Range	Default
S2-01	Sequence Timer 1 Start Time	12:00AM to 11:59PM < >	12:00AM < >
S2-06	Sequence Timer 2 Start Time	12:00AM to 11:59PM < >	12:00AM < >
S2-11	Sequence Timer 3 Start Time	12:00AM to 11:59PM < >	12:00AM < >
S2-16	Sequence Timer 4 Start Time	12:00AM to 11:59PM < >	12:00AM < >

<|> Default is 00:00 and range is 00:00 to 24:00 when o4-20 is set to 1 (24-hour).

**■ S2-02/S2-07/S2-12/S2-17: Sequence Timers 1 to 4 Stop Time**

Sets the stop times for timers 1 to 4. The values must be set greater than or equal to S2-01/S2-06/S2-11/S2-16.

No.	Name	Setting Range	Default
S2-02	Sequence Timer 1 Stop Time	00:00 to 24:00	00:00
S2-07	Sequence Timer 2 Stop Time	00:00 to 24:00	00:00
S2-12	Sequence Timer 3 Stop Time	00:00 to 24:00	00:00
S2-17	Sequence Timer 4 Stop Time	00:00 to 24:00	00:00

**■ S2-03/S2-08/S2-13/S2-18: Sequence Timers 1 to 4 Day Selection**

Sets the days for which sequence timers 1 to 4 are active.

No.	Name	Setting Range	Default
S2-03	Sequence Timer 1 Day Selection	0 to 10	0
S2-08	Sequence Timer 2 Day Selection	0 to 10	0
S2-13	Sequence Timer 3 Day Selection	0 to 10	0
S2-18	Sequence Timer 4 Day Selection	0 to 10	0

## 5.12 S: Special Parameters

---

**Setting 0: Timer Disabled**

**Setting 1: Daily**

**Setting 2: Mon - Fri**

**Setting 3: Sat - Sun**

**Setting 4: Monday**

**Setting 5: Tuesday**

**Setting 6: Wednesday**

**Setting 7: Thursday**

**Setting 8: Friday**

**Setting 9: Saturday**

**Setting 10: Sunday**

### ■ S2-04/S2-09/S2-14/S2-19: Sequence Timers 1/2/3/4 Selection

Sets the action that occurs when sequence timers 1 to 4 are active.

- Note:**
1. Setting 3 is available in drive software versions PRG: 8552 and later.
  2. Setting 3 is not available in drive models 4A0930 and 4A1200.

No.	Name	Setting Range	Default
S2-04	Sequence Timer 1 Selection	0 to 3	0
S2-09	Sequence Timer 2 Selection	0 to 3	0
S2-14	Sequence Timer 3 Selection	0 to 3	0
S2-19	Sequence Timer 4 Selection	0 to 3	0

**Setting 0: Digital Output Only**

**Setting 1: Run**

**Setting 2: Run - PI Disable**

**Setting 3: Allow Alternation**

When Sequence Selection is set to Allow Alternation and that timer is enabled (S2-03, S2-08, S2-13, S2-18 > 0), the drive will only allow MEMOBUS alternation to occur during the time specified in the corresponding Sequence Timer. Alternation is disabled when the timer deactivates.

### ■ S2-05/S2-10/S2-15/S2-20: Sequence Timers 1/2/3/4 Reference Source

Selects the frequency reference source used for running the drive when sequence timers 1 to 4 are active (only applicable when S2-04/S2-09/S2-14/S2-19 are set to 1 or 2).

No.	Name	Setting Range	Default
S2-05	Sequence Timer 1 Reference Source	0 to 5	0
S2-10	Sequence Timer 2 Reference Source	0 to 5	0
S2-15	Sequence Timer 3 Reference Source	0 to 5	0
S2-20	Sequence Timer 4 Reference Source	0 to 5	0

**Setting 0: Operator (d1-01)**

**Setting 1: Operator (d1-02)**

**Setting 2: Operator (d1-03)**

**Setting 3: Operator (d1-04)**

**Setting 4: Terminals**

**Setting 5: Serial Communication**

---

## ◆ Examples of Sequence Timers

### ■ Sequence Timer Example 1

Set the parameters as shown in [Table 5.23](#) to accomplish the timer sequencing in [Figure 5.51](#).

Table 5.23 Sequence Timer Example 1 Parameter Settings

No.	Name	Setting	Comment
S2-01	Sequence Timer 1 Start Time	05:00	
S2-02	Sequence Timer 1 Stop Time	15:00	
S2-03	Sequence Timer 1 Day Selection	2	Mon to Fri
S2-04	Sequence Timer 1 Selection	1	Run
S2-05	Sequence Timer 1 Reference Source	0	Operator (d1-01)
S2-06	Sequence Timer 2 Start Time	19:00	
S2-07	Sequence Timer 2 Stop Time	22:00	
S2-08	Sequence Timer 2 Day Selection	2	Mon to Fri
S2-09	Sequence Timer 2 Selection	2	Run PI Disable
S2-10	Sequence Timer 2 Reference Source	1	Operator (d1-02)
S2-11	Sequence Timer 3 Start Time	06:00	
S2-12	Sequence Timer 3 Stop Time	14:00	
S2-13	Sequence Timer 3 Day Selection	3	Sat to Sun
S2-14	Sequence Timer 3 Selection	1	Run
S2-15	Sequence Timer 3 Reference Source	2	Operator (d1-03)
S2-16	Sequence Timer 4 Start Time	17:00	
S2-17	Sequence Timer 4 Stop Time	21:00	
S2-18	Sequence Timer 4 Day Selection	10	Sun
S2-19	Sequence Timer 4 Selection	0	Digital Output Only
S2-20	Sequence Timer 4 Reference Source	0	n/a

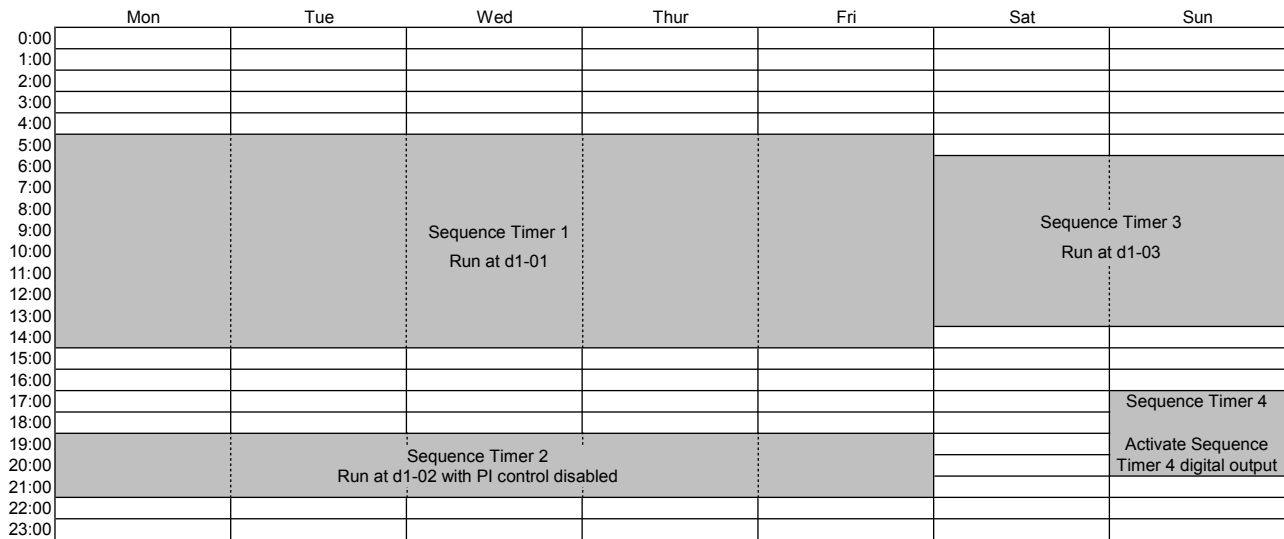

Figure 5.51 Sequence Timer Example 1

### ■ Sequence Timer Example 2

Set the parameters as shown in [Table 5.24](#) to accomplish the timer sequencing in [Figure 5.52](#).

Table 5.24 Sequence Timer Example 2 Parameter Settings

No.	Name	Setting	Comment
S2-01	Sequence Timer 1 Start Time	00:00	
S2-02	Sequence Timer 1 Stop Time	24:00	
S2-03	Sequence Timer 1 Day Selection	2	Mon to Fri
S2-04	Sequence Timer 1 Selection	1	Run
S2-05	Sequence Timer 1 Reference Source	0	Operator (d1-01)
S2-06	Sequence Timer 2 Start Time	06:00	

## 5.12 S: Special Parameters

No.	Name	Setting	Comment
S2-07	Sequence Timer 2 Stop Time	06:00	
S2-08	Sequence Timer 2 Day Selection	3	Sat to Sun
S2-09	Sequence Timer 2 Selection	1	Run
S2-10	Sequence Timer 2 Reference Source	2	Operator (d1-03)
S2-11	Sequence Timer 3 Start Time	0:00	n/a
S2-12	Sequence Timer 3 Stop Time	0:00	n/a
S2-13	Sequence Timer 3 Day Selection	0	Timer Disabled
S2-14	Sequence Timer 3 Selection	0	n/a
S2-15	Sequence Timer 3 Reference Source	0	n/a
S2-16	Sequence Timer 4 Start Time	00:00	n/a
S2-17	Sequence Timer 4 Stop Time	00:00	n/a
S2-18	Sequence Timer 4 Day Selection	0	Timer Disabled
S2-19	Sequence Timer 4 Selection	0	n/a
S2-20	Sequence Timer 4 Reference Source	0	n/a

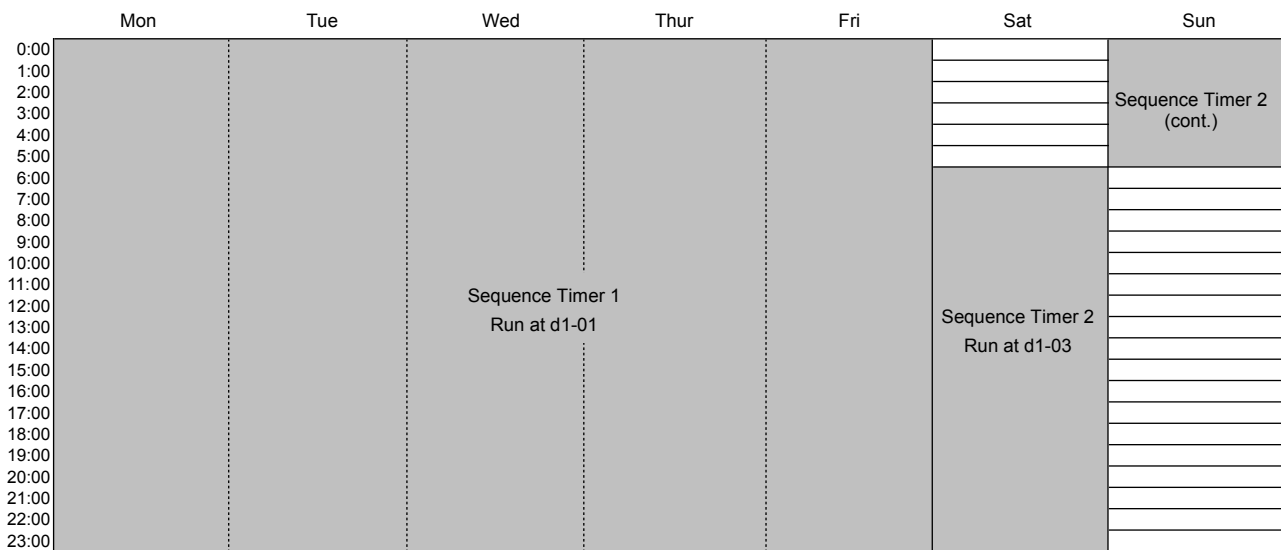

Figure 5.52 Sequence Timer Example 2

### ■ Sequence Timer Example 3

Set the parameters as shown in [Table 5.25](#) to accomplish the timer sequencing in [Figure 5.53](#).

Table 5.25 Sequence Timer Example 3 Parameter Settings

No.	Name	Setting	Comment
S2-01	Sequence Timer 1 Start Time	05:00	
S2-02	Sequence Timer 1 Stop Time	15:00	
S2-03	Sequence Timer 1 Day Selection	2	Mon to Fri
S2-04	Sequence Timer 1 Selection	1	Run
S2-05	Sequence Timer 1 Reference Source	0	Operator (d1-01)
S2-06	Sequence Timer 2 Start Time	15:00	
S2-07	Sequence Timer 2 Stop Time	22:00	
S2-08	Sequence Timer 2 Day Selection	2	Mon to Fri
S2-09	Sequence Timer 2 Selection	2	Run PI Disable
S2-10	Sequence Timer 2 Reference Source	1	Operator (d1-02)
S2-11	Sequence Timer 3 Start Time	09:00	
S2-12	Sequence Timer 3 Stop Time	24:00	
S2-13	Sequence Timer 3 Day Selection	9	Sat



No.	Name	Setting	Comment
S2-14	Sequence Timer 3 Selection	1	Run
S2-15	Sequence Timer 3 Reference Source	2	Operator (d1-03)
S2-16	Sequence Timer 4 Start Time	0:00	n/a
S2-17	Sequence Timer 4 Stop Time	0:00	n/a
S2-18	Sequence Timer 4 Day Selection	0	Timer Disabled
S2-19	Sequence Timer 4 Selection	0	n/a
S2-20	Sequence Timer 4 Reference Source	0	n/a

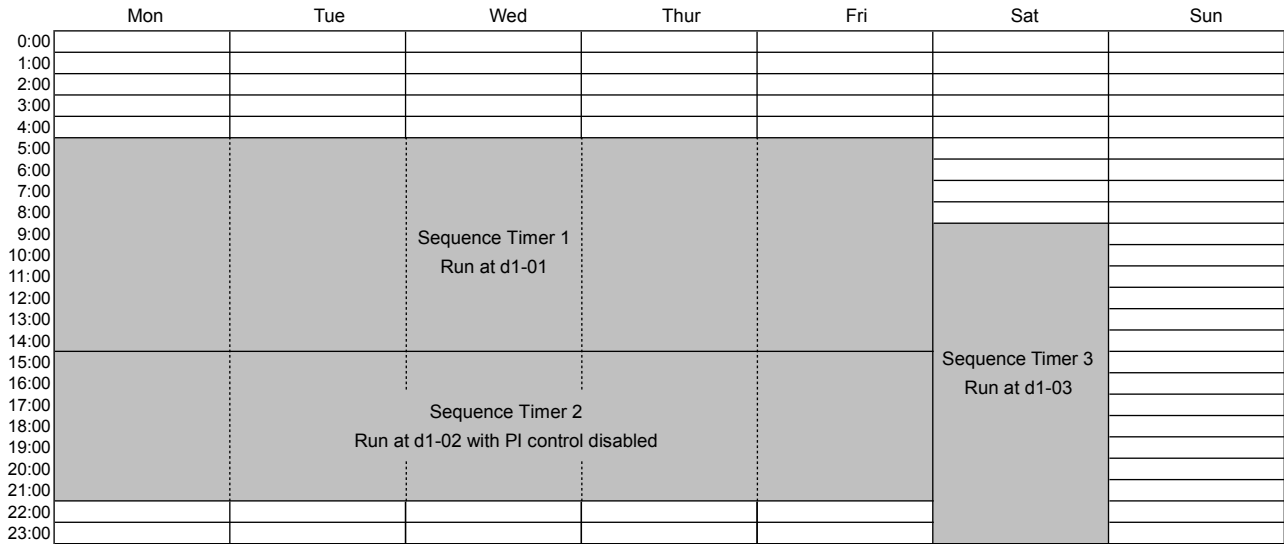

Figure 5.53 Sequence Timer Example 3

### 5.13 T: Motor Tuning

Auto-Tuning automatically sets and tunes parameters required for optimal motor performance.

*Refer to T: Motor Tuning on page 352* for a list of T parameters in the bypass.

## 5.14 U: Monitor Parameters

Monitor parameters let the user view various aspects of drive performance using the HOA keypad display. Some monitors can be output from terminals FM and AM by assigning the specific monitor parameter number (U□-□□) to H4-01 and H4-04. *Refer to H4-01, H4-04: Multi-Function Analog Output Terminal FM, AM Monitor Selection on page 165* for details on assigning functions to an analog output.

### ◆ UB: Bypass Monitors

These monitors display various aspects of bypass control. *Refer to UB: Bypass Control Monitors on page 354* for a complete list of UB-□□ monitors and descriptions.

### ◆ U1: Operation Status Monitors

Status monitors display drive status data such as output frequency and output current. *Refer to U1: Operation Status Monitors on page 355* for a complete list of U1-□□ monitors and descriptions.

### ◆ U2: Fault Trace

Use these monitor parameters to view the status of various drive aspects when a fault occurs.

This information is helpful for determining the cause of a fault. *Refer to U2: Fault Trace on page 357* for a complete list of U2-□□ monitors and descriptions.

U2-□□ monitors are not reset when the drive is initialized.

**Note:** Fault histories are not kept when CPF00, CPF01, CPF06, CPF24, oFA00, oFb00, oFC00, Uv1, Uv2, or Uv3 occur.

### ◆ U3: Fault History

These parameters display faults that have occurred during operation as well as the drive operation time when those faults occurred. *Refer to U3: Fault History on page 358* for a complete list of U3-□□ monitors and descriptions.

U3-□□ monitors are not reset when the drive is initialized.

**Note:** Fault histories are not kept when CPF00, CPF01, CPF06, CPF24, oFA00, oFb00, oFC00, Uv1, Uv2, or Uv3 occur.

### ◆ U4: Maintenance Monitors

Maintenance monitors show:

- Runtime data of the drive and cooling fans and number of Run commands issued
- Maintenance data and replacement information for various drive components
- kWh data
- Highest peak current that has occurred and output frequency at the time the peak current occurred
- Motor overload status information
- Detailed information about the present Run command and frequency reference source selection

*Refer to U4: Maintenance Monitors on page 360* for a complete list of U4-□□ monitors and descriptions.

### ◆ U5: PI Monitors

These monitors display various aspects of PI control. *Refer to PI Block Diagram on page 130* for details on how these monitors display PI data. *Refer to U5: PI Monitors on page 361* for a complete list of U5-□□ monitors and descriptions.

## 5.15 Z: Bypass Parameters

Z parameters control bypass-specific functions.

### ◆ Z1: Bypass Control System

#### ■ Z1-01: Initialize

Sets parameters to default values.

**Note:** Stop the bypass before changing this parameter in bypass controller software versions VST800400 and later.

No.	Name	Setting Range	Default
Z1-01	Initialize	0 to 3	0

**Setting 0: No Initialize**

**Setting 1: Set all parameters to default values**

**Setting 2: Set only Bypass Controller parameters to default values**

**Setting 3: Set only Drive Controller parameters to default values**

#### ■ Z1-02: Password

Allows and restricts access to all parameters. Setting this value equal to the value in Z1-03 toggles access to all parameter settings, except Z1-02. If the value entered to Z1-02 matches the value entered to Z1-03, the access to all parameters is denied or granted.

No.	Name	Setting Range	Default
Z1-02	Password	–	–

#### ■ Z1-03: Password Change

The value entered to this parameter is the password.

No.	Name	Setting Range	Default
Z1-03	Password Change	0 to 9999	0

#### ■ Z1-05: Auto Transfer to Bypass Upon Drive Fault

Switches operation to Bypass mode when the drive is running and a drive fault occurs. When the fault is cleared, operation will switch back to Drive mode

No.	Name	Setting Range	Default
Z1-05	Auto Transfer to Bypass Upon Drive Fault	0, 1	0

**Setting 0: Disable**

**Setting 1: Enable**

#### ■ Z1-06: Power-Up Mode

Determines the mode of the Bypass Control upon power-up.

No.	Name	Setting Range	Default
Z1-06	Power-Up Mode	0 to 4	0

**Setting 0: OFF**

When drive powers up , it will be in “OFF” mode and will need an “AUTO” or “HAND” command to run.

**Setting 1: AUTO-DRIVE**

When drive powers up , the drive will get an “AUTO” command and needs an “OFF” command to stop.

**Setting 2: HAND-DRIVE**

When drive powers up , the drive will get a "HAND” command and needs an “OFF” command to stop.

**Setting 3: AUTO-BYPASS**

When drive powers up , the bypass will get an “AUTO” command and needs an “OFF” command to stop.

**Setting 4: HAND-BYPASS**

When drive powers up, the bypass will get a "HAND" command and needs an "OFF" command to stop.

**■ Z1-07: Speed Reference Select**

Selects the frequency reference source 1.

- Note:**
1. Default is 1 in bypass controller software versions VST800298 and later. Default is 0 in bypass controller software versions VST800297 and earlier.
  2. If a Run command is input to the drive, but the frequency reference entered is 0 or below the minimum frequency, the AUTO or HAND indicator LED on the HOA keypad will light and the OFF indicator will flash.

No.	Name	Setting Range	Default
Z1-07	Speed Reference Select	0 to 3	1

**Setting 0: HOA Keypad**

Using this setting, the frequency reference can be input by:

- switching between the multi-speed references from d1-01 to d1-04.
- entering the frequency reference on the operator keypad.

**Setting 1: Analog Input Terminals**

Using this setting, an analog frequency reference can be entered as a voltage or current signal from terminals A1 or A2.

**Voltage Input**

Voltage input can be used at any of the two analog input terminals. Make the settings as described in [Table 5.26](#) for the input used.

**Table 5.26 Analog Input Settings for Frequency Reference Using Voltage Signals**

Terminal	Signal Level	Parameter Settings				Notes
		Signal Level Selection	Function Selection	Gain	Bias	
A1	0 to 10 V with Zero Limit	H3-01 = 0	H3-02 = 0 (Frequency Reference Bias)	H3-03	H3-04	Set Jumper S1 on the control board to "V" for voltage input.
	0 to 10 V without Zero Limit	H3-01 = 1				
A2	0 to 10 V with Zero Limit	H3-09 = 0	H3-10 = 0 (Frequency Reference Bias)	H3-11	H3-12	
	0 to 10 V without Zero Limit	H3-09 = 1				

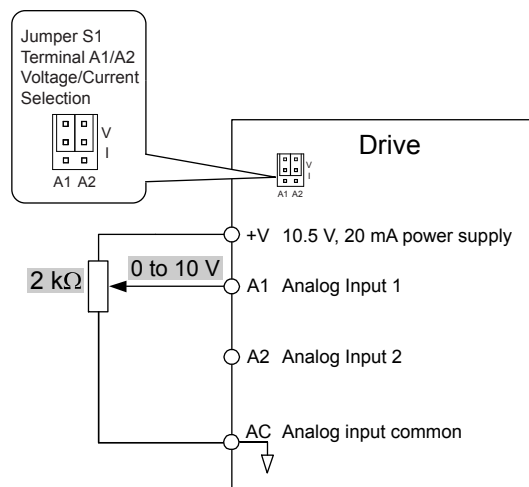

**Figure 5.54 Setting the Frequency Reference as a Voltage Signal at Terminal A1**

Use the wiring example shown in [Figure 5.54](#) for any other analog input terminals. When using input terminals A1 and A2, make sure Jumper S1 is set for voltage input.

**Current Input**

## 5.15 Z: Bypass Parameters

Input terminals A1 and A2 can accept a current input signal. Refer to [Table 5.27](#) to set terminals A1 and A2 for current input.

**Table 5.27 Analog Input Settings for Frequency Reference Using a Current Signal**

Terminal	Signal Level	Parameter Settings				Notes
		Signal Level Selection	Function Selection	Gain	Bias	
A1	4 to 20 mA	H3-01 = 2	H3-02 = 0 (Frequency Reference Bias)	H3-03	H3-04	Make sure to set Jumper S1 on the control board to "I" for current input.
	0 to 20 mA	H3-01 = 3				
A2	4 to 20 mA	H3-09 = 2	H3-10 = 0 (Frequency Bias)	H3-11	H3-12	
	0 to 20 mA	H3-09 = 3				

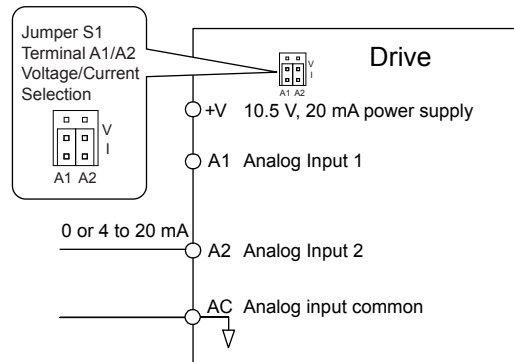

**Figure 5.55 Setting the Frequency Reference as a Current Signal to Terminal A2**

### Switching between Main/Auxiliary Frequency References

The frequency reference input can be switched between the analog terminals A1 and A2 using multi-speed inputs.

#### Setting 2: BACnet, MEMOBUS/Modbus, P1, or N2 Communications

This setting requires entering the frequency reference via the RS-485 serial communications port (control terminals TXX+ and TXX-).

#### Setting 3: Option Card

This setting requires entering the frequency reference via an option board plugged into connector CN5 on the bypass control board. Consult the option card manual for instructions on integrating the drive with the communication system.

### ■ Z1-08: Run Command Select

Determines the source of the Auto Mode RUN command used by the Bypass Controller.

No.	Name	Setting Range	Default
Z1-08	Run Command Select	1 to 3	1

#### Setting 0: HOA Keypad

#### Setting 1: Bypass Controller Digital Input

This setting requires entering the Run command via the digital input terminals.

#### Setting 2: BACnet or MEMOBUS/Modbus Communications

This setting requires entering the Run command via serial communications by connecting the RS-485 serial communication cable to control terminals TXX+ and TXX- on the terminal block. [Refer to MEMOBUS/Modbus Configuration on page 396](#) for instructions.

#### Setting 3: Option Card

This setting requires entering the Run command via the communication option board by plugging a communication option board into the CN5 port on the control PCB. Refer to the option card manual for instructions on integrating the bypass into the communication system.

### ■ Z1-09: HAND Mode Drive Speed Reference

The speed reference used when the Drive is running in HAND mode.

No.	Name	Setting Range	Default
Z1-09	HAND Mode Drive Speed Reference	0.0 to 60.0 Hz </>	10.0 Hz </>

<1> Values are given in Hz, but actual values are dependent upon unit settings using drive parameters o1-03, o1-09, o1-10, and o1-11.

### ■ Z1-10: Smoke Purge Preset Frequency Reference

Sets the speed at which the drive will run when the Smoke Purge Drive input is active.

No.	Name	Setting Range	Default
Z1-10	Smoke Purge Preset Frequency Reference	0.0 to 60.0 Hz </>	60.0 Hz </>

<1> Values are given in Hz, but actual values are dependent upon unit settings using drive parameters o1-03, o1-09, o1-10, and o1-11.

### ■ Z1-11: 2-Motor AND/OR Function Select

No.	Name	Setting Range	Default
Z1-11	2-Motor AND/OR Function Select	0 to 10	0

**Setting 0: Disabled (Ignore Digital Inputs)**

**Setting 1: Always Use Only Motor 1**

**Setting 2: Always Use Only Motor 2**

**Setting 3: Always Use Motor 1 and Motor 2**

**Setting 4: OR Function Motor Selected by Digital Input in HAND and AUTO Modes**

**Setting 5: OR Function Uses Motor 1 in HAND Mode and Motor Selected by Digital Input in AUTO Mode**

**Setting 6: OR Function Uses Motor 2 in HAND Mode and Motor Selected by Digital Input in AUTO Mode**

**Setting 7: AND/OR Function Motor Selected (1, 2, or both) by (2) Digital Inputs in HAND and AUTO Modes**

**Setting 8: AND/OR Function Uses Motor 1 in HAND Mode and Motor Selected (1, 2, or both) by (2) Digital Inputs in AUTO Mode**

**Setting 9: AND/OR Function Uses Motor 2 in HAND Mode and Motor Selected (1, 2, or both) by (2) Digital Inputs in AUTO Mode**

**Setting 10: AND/OR Function Uses Motor 1 and Motor 2 in HAND Mode and Motor Selected (1, 2, or both) by (2) Digital Inputs in AUTO Mode**

### ■ Z1-12 to Z1-15: Run Delay with Preset Speed

Parameters Z1-12 to Z1-15 allow running the Bypass at a preset speed before the BAS Interlock Input is active and continuing at the preset speed for a delay time after the BAS Interlock Input becomes active. Refer to [Figure 5.56](#) to [Figure 5.59](#) for examples.

### ■ Z1-12: Run Delay Time

Delays the drive or bypass Run after RUN, RUN ENABLE, and RUN INTERLOCK are all asserted.

No.	Name	Setting Range	Default
Z1-12	Run Delay Time	0.0 to 300.0 s	0.0 s

### ■ Z1-13: Pre-Interlock Run Select

Allows running at a preset speed starting immediately upon entering a Run command, ignoring the BAS Interlock Input. The drive frequency reference stays at this preset speed until the Run Delay Time (Z1-12) times out.

No.	Name	Setting Range	Default
Z1-13	Pre-Interlock Run Select	0, 1	0

**Setting 0: Disabled**

**Setting 1: Enable Delay Time Only**

### ■ Z1-14: Run Delay Frequency Reference

Sets the frequency used while delaying the Run command.

No.	Name	Setting Range	Default
Z1-14	Run Delay Frequency Reference	0.0 to 60.0 Hz </>	60.0 Hz </>

## 5.15 Z: Bypass Parameters

<1> Values are given in Hz, but actual values are dependent upon unit settings using drive parameters o1-03, o1-09, o1-10, and o1-11.

### ■ Z1-15: Interlock Wait Time

When an input is programmed for Interlock and the time set to this parameter is reached before the Interlock input goes active, a fault will be declared. The default setting of 0.0 will never time out.

No.	Name	Setting Range	Default
Z1-15	Interlock Wait Time	0.0 to 300.0 s	0.0 s

#### Run Delay with Preset Speed Examples

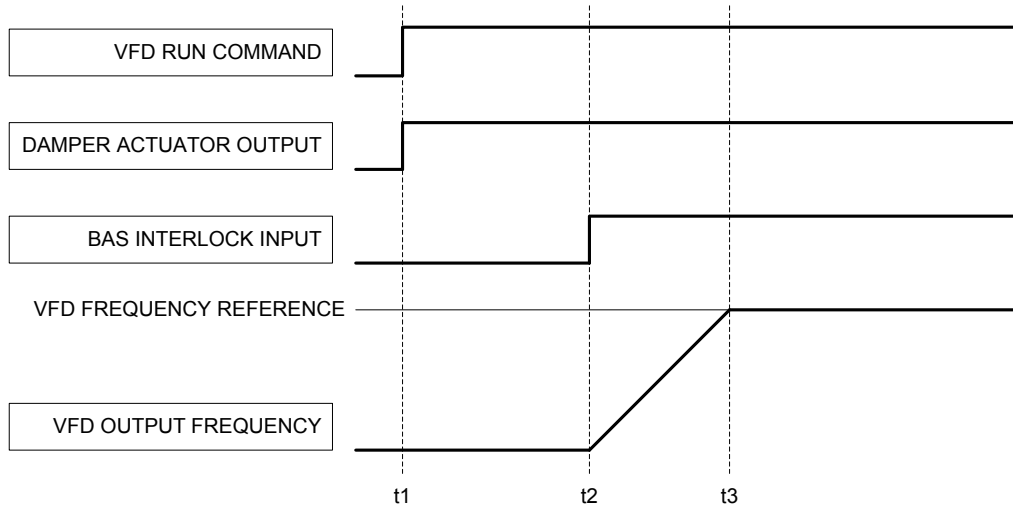

Parameter Settings:  
 Z1-12 Run Delay Time = 0.0 sec  
 Z1-13 Pre Int Run Sel = 0 (Disabled)  
 Z1-14 Run Delay Fref = 60.0 Hz  
 Z1-15 Interlock Wait Tm = 0.0 sec (Never Time Out)

Figure 5.56 Run Delay with Preset Speed Example: Default Setting



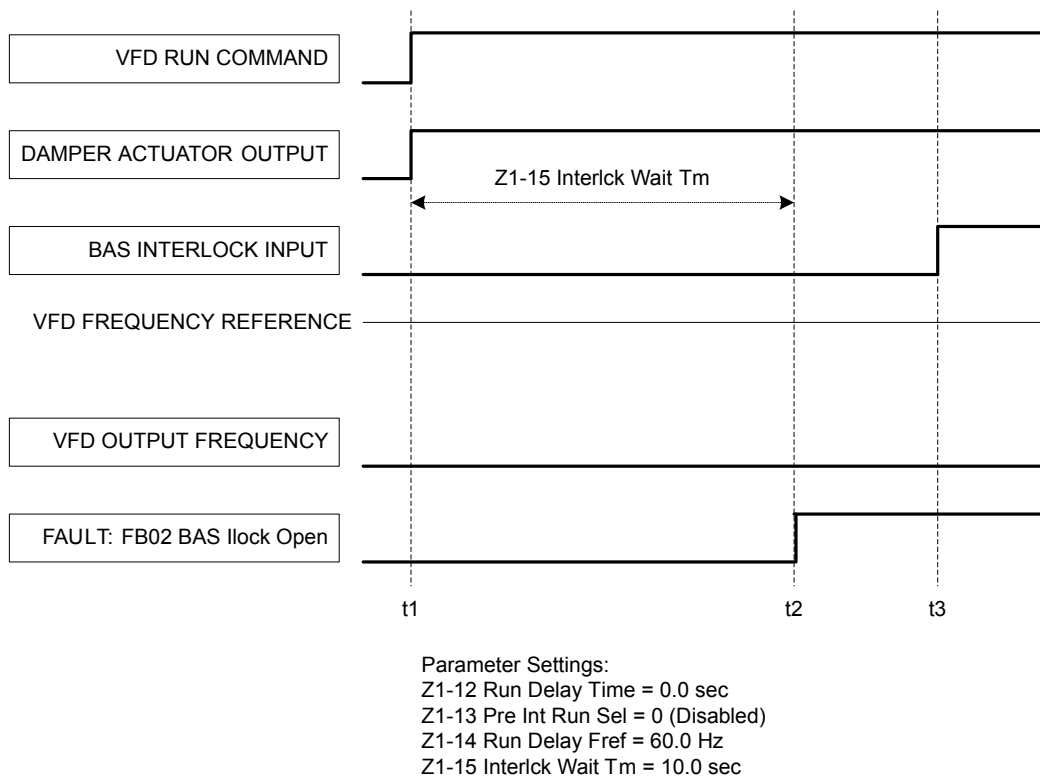

Figure 5.57 Run Delay with Preset Speed Example: BAS Interlock Wait Time Fault

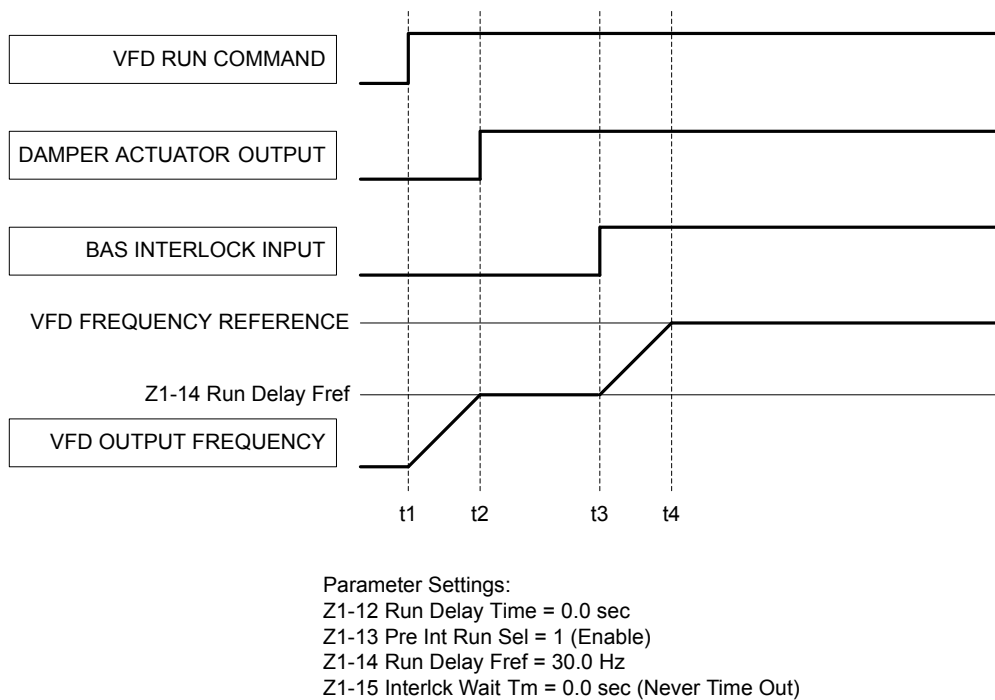
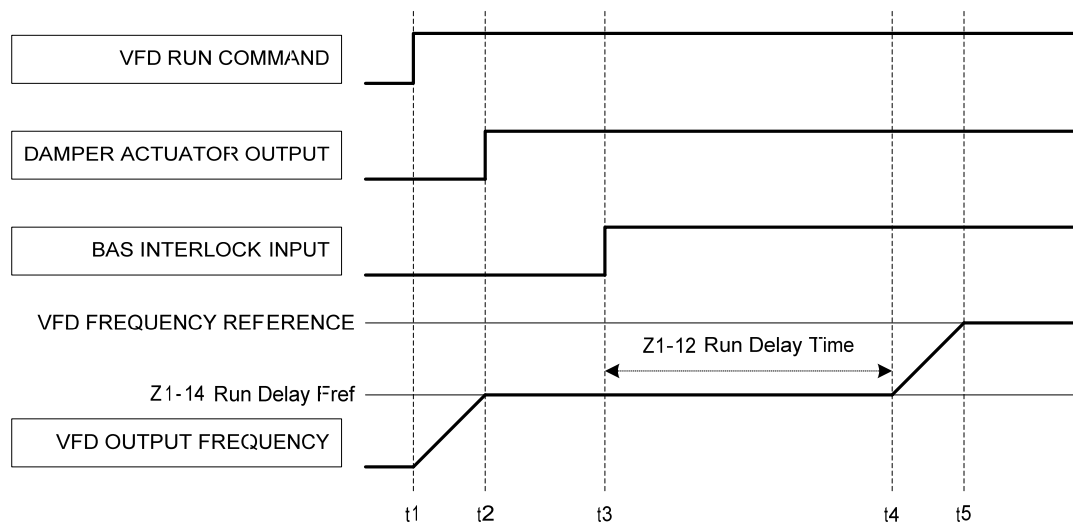

Figure 5.58 Run Delay with Preset Speed Example: Preset Speed

## 5.15 Z: Bypass Parameters



Parameter Settings:  
 Z1-12 Run Delay Time = 10.0 sec  
 Z1-13 Pre Int Run Sel = 1 (Enable)  
 Z1-14 Run Delay Fref = 30.0 Hz  
 Z1-15 Interlock Wait Tm = 0.0 sec (Never Time: Out)

Figure 5.59 Run Delay with Preset Speed Example: Preset Speed with Run Delay

### ■ Z1-16 to Z1-25: Bypass Energy Savings

Allows saving energy and reducing harmonics by automatically switching to Bypass while in Drive Mode.

Users can select one of two methods using parameter Z1-16, Energy Savings Mode, to switch into Energy Savings:

**Frequency Only** Setting Z1-16 to 1 enables Energy Savings based on frequency only. The Z1000 Bypass will automatically switch to Bypass when the following conditions are met for Z1-22, Energy Savings Mode Time:

- Drive frequency reference is within the value set to Z1-19, Energy Savings Mode Frequency Reference Deadband, of Z1-17, Energy Savings Mode Frequency.
- Drive output frequency is within the value set to Z1-20: Energy Savings Mode Output Frequency Deadband of Z1-17, Energy Savings Mode Frequency.

**Frequency and Output Current** Setting Z1-16 to 2 enables Energy Savings based on frequency and output current. The Z1000 Bypass will automatically switch to Bypass when the frequency only conditions are met and the drive output current is within Z1-21, Energy Savings Mode Output Current Deadband, of Z1-18, Energy Savings Mode Output Current Level.

When the above conditions are met, the system:

1. Increases the drive frequency reference by the value set to Z1-23, Energy Savings Mode Frequency Reference Increase
2. Waits for the drive output frequency to match the frequency reference
3. Sets the drive to baseblock
4. Removes the effect of Z1-23 from the drive frequency reference
5. Delays per L2-03, Minimum Baseblock time
6. Opens drive output contactor K2
7. Delays per Z1-24, Contactor Open Delay Time
8. Closes Bypass contactor K3 and transfers to Bypass.

When the drive frequency reference falls out of Z1-19, Energy Savings Mode Frequency Reference Deadband, of Z1-17, Energy Savings Mode Frequency, the system:

1. Transfers motor control back to the drive
2. Opens Bypass contactor K3 with the drive still baseblocked
3. Delays per the sum of Z1-24, Contactor Open Delay Time, and L2-03, Minimum Baseblock Time
4. Closes drive output contactor K2
5. Delays per Z1-25, Contact Close Delay Time
6. Releases the drive from baseblock

7. Then the drive catches a spinning motor via Speed Search and follows frequency reference to take control. Refer to *Figure 5.60* for an example of the sequence that is followed when entering and exiting the Energy Savings Mode.

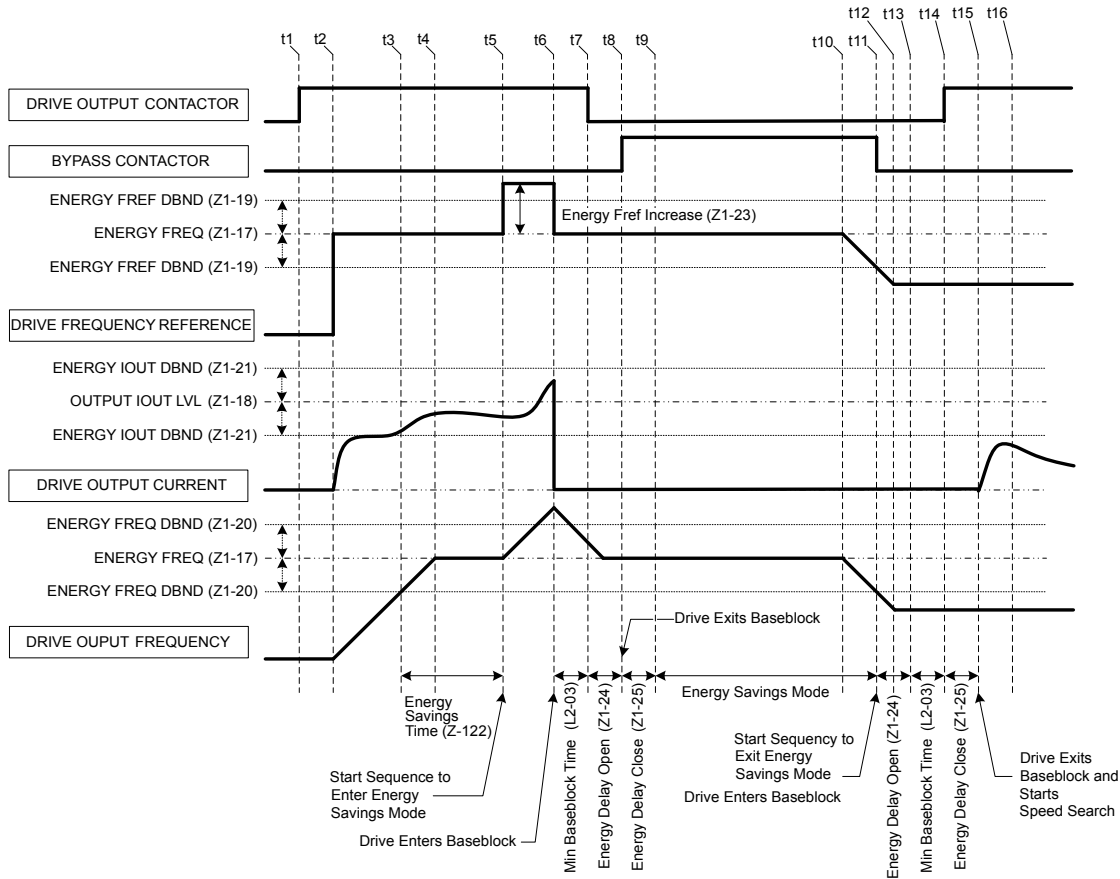

Figure 5.60 Drive Bypass Energy Savings Mode Sequence Example

**Z1-16: Energy Savings Mode**

Enables and disables the Energy Savings Mode.

No.	Name	Setting Range	Default
Z1-16	Energy Savings Mode Enable	0 to 2	0

Setting 0: Disable

Setting 1: Enable (Freq)

Setting 2: Enable (Freq + Output Current)

**Z1-17: Energy Savings Mode Frequency**

Sets the value of the drive frequency reference for use in comparison to enter or exit Energy Savings mode.

No.	Name	Setting Range	Default
Z1-17	Energy Savings Mode Frequency	0.0 to 60.0 Hz <1>	60.0 Hz <1>

<1> Values are given in Hz, but actual values are dependent upon unit settings using drive parameters o1-03, o1-09, o1-10, and o1-11.

**Z1-18: Energy Savings Mode Output Current Level**

Allows system to switch when the output current rises above this level of motor rated current for time specified in Z1-22.

No.	Name	Setting Range	Default
Z1-18	Energy Savings Mode Output Current Level	0.0 to 100.0%	0.0%

**Z1-19: Energy Savings Mode Frequency Reference Deadband**

Sets the tolerance around the drive frequency reference value during comparisons to enter or exit Energy Savings mode

## 5.15 Z: Bypass Parameters

No.	Name	Setting Range	Default
Z1-19	Energy Savings Mode Frequency Reference Deadband	0.0 to 5.0 Hz </>	0.5 Hz </>

<1> Values are given in Hz, but actual values are dependent upon unit settings using drive parameters o1-03, o1-09, o1-10, and o1-11.

### ■ Z1-20: Energy Savings Mode Output Frequency Deadband

Sets the tolerance around the drive output frequency value during comparisons to enter or exit Energy Savings mode.

No.	Name	Setting Range	Default
Z1-20	Energy Savings Mode Output Frequency Deadband	0.0 to 5.0 Hz </>	0.5 Hz </>

<1> Values are given in Hz, but actual values are dependent upon unit settings using drive parameters o1-03, o1-09, o1-10, and o1-11.

### ■ Z1-21: Energy Savings Mode Output Current Deadband

Sets the tolerance around the drive output current value during comparisons to enter or exit Energy Savings mode as a percentage of motor rated current.

No.	Name	Setting Range	Default
Z1-21	Energy Savings Mode Output Current Deadband	0.0 to 30.0%	15.0%

### ■ Z1-22: Energy Savings Mode Time

Sets the time that the drive frequency reference and drive output frequency must be within the set limits before transferring to Energy Savings mode.

No.	Name	Setting Range	Default
Z1-22	Energy Savings Mode Time	10 to 60000 s	30 s

### ■ Z1-23: Energy Savings Mode Frequency Reference Increase

Sets the value to add to the drive Frequency Reference when starting the transfer to bypass mode the drive when entering the Energy Savings Mode.

No.	Name	Setting Range	Default
Z1-23	Energy Savings Mode Frequency Reference Increase	0.0 to 10.0 Hz </>	6.0 Hz </>

<1> Values are given in Hz, but actual values are dependent upon unit settings using drive parameters o1-03, o1-09, o1-10, and o1-11.

### ■ Z1-24: Contactor Open Delay Time

Sets the time to delay after commanding the drive output contactor K2 or bypass contactor K3 or 2-Motor AND/OR contactors K4 and K5 to open to allow the contacts to open.

No.	Name	Setting Range	Default
Z1-24	Contactor Open Delay Time	0.0 to 5.0 s	0.2 s

### ■ Z1-25: Contactor Close Delay Time

Sets the time to delay after commanding the drive output contactor K2 or bypass contactor K3 or 2-Motor AND/OR contactors K4 and K5 to open to allow the contacts to close.

No.	Name	Setting Range	Default
Z1-25	Contactor Close Delay Time	0.0 to 5.0 s	0.2 s

### ■ Z1-27 to Z1-29: Control Voltage Protection

The Bypass controller monitors the voltage to the contactor coils and the Bypass controller power supply. The controller will detect brownout and blackout conditions. Blackout and brownout conditions will trigger an FB08 or FB09 fault and de-energize the contactor coils.

### ■ Z1-27: Phase Loss Brownout Voltage Level

Sets the brownout condition voltage level.

No.	Name	Setting Range	Default
Z1-27	Phase Loss Brownout Voltage Level	0 to 150 V	98 V

**■ Z1-28: Phase Loss Brownout Detection Time**

Sets the time that the input voltage is continuously measured to be below the Brownout Voltage level before declaring a brownout fault.

No.	Name	Setting Range	Default
Z1-28	Phase Loss Brownout Detection Time	0.0 to 300.0 s	3.0 s

**■ Z1-29: Phase Loss Blackout Voltage Level**

Sets the voltage level below which is considered a blackout condition.

No.	Name	Setting Range	Default
Z1-29	Phase Loss Blackout Voltage Level	0 to 150 V0	0 V

**■ Z1-30: EF0 Fault Delay Time**

Sets the time between declaring a drive fault and opening the drive and bypass contactors.

No.	Name	Setting Range	Default
Z1-30	EF0 Fault Delay Time	0.0 to 300.0 s	1.0 s

**■ Z1-31: Loss of Load Detection Enable**

No.	Name	Setting Range	Default
Z1-31	Loss of Load Detection Enable	0 to 2	0

**Setting 0: Disable**

**Setting 1: Enable and Declare Fault**

**Setting 2: Enable and Alarm Only**

**■ Z1-32: Loss of Load Drive Frequency**

Sets the value to which the drive output frequency must be equal to or greater than for the drive to detect a loss of load.

No.	Name	Setting Range	Default
Z1-32	Loss of Load Drive Frequency	0.0 to 60.0 Hz </>	60.0 Hz </>

<1> Values are given in Hz, but actual values are dependent upon unit settings using drive parameters o1-03, o1-09, o1-10, and o1-11.

**■ Z1-33: Loss of Load Drive Output Current**

Sets the value to which the drive output current must be equal to or less than for the drive to detect a loss of load.

No.	Name	Setting Range	Default
Z1-33	Loss of Load Drive Output Current	0.0 to 999.9 A	0.0 A

**■ Z1-34: Loss of Load Drive Time**

While in Drive mode, the Loss of Load detection conditions must be met for the length of time entered here before detecting a loss of load.

No.	Name	Setting Range	Default
Z1-34	Loss of Load Drive Time	0.0 to 300.0 s	1.0 s

**■ Z1-35: Loss of Load Bypass Output Current**

The motor current must be equal to or less than this value to detect a loss of load.

No.	Name	Setting Range	Default
Z1-35	Loss of Load Bypass Output Current	0.0 to 999.9	0.0 A

**■ Z1-36: Loss of Load Bypass Time**

While in Bypass mode, the Loss of Load detection conditions must be met for the length of time entered here before detecting a loss of load.

## 5.15 Z: Bypass Parameters

No.	Name	Setting Range	Default
Z1-36	Loss of Load Bypass Time	0.0 to 300.0	1.0 s

### ■ Z1-37: Set Time

Changes the LCD display to time setting to set the Real Time Clock.

**Note:** Setting 2 is added in bypass controller software version VST800298. Setting 2 is not available in bypass controller software versions VST800297 and earlier.

No.	Name	Setting Range	Default
Z1-37	Set Time	0 to 2	0

**Setting 0: Normal Display**

**Setting 1: Displays Time and Date Setting Mode**

**Setting 2: Reset Time**

### ■ Z1-38: HOA Source Select

No.	Name	Setting Range	Default
Z1-38	HOA Source Select	0 to 2	0

**Setting 0: Operator**

The HOA keypad controls the HAND/OFF/AUTO commands.

**Setting 1: Digital Inputs**

The H1-□□ multi-function digital input parameters control the HAND/OFF/AUTO commands.

**Setting 2: Serial Communications**

The serial communications protocol selected in parameter Z3-01 control the HAND/OFF/AUTO commands.

### ■ Z1-39: Drive/Bypass Source Select

No.	Name	Setting Range	Default
Z1-39	Drive/Bypass Source Select	0 to 2	0

**Setting 0: Operator**

The HOA keypad selects the Drive or Bypass as the source.

**Setting 1: Digital Inputs**

The H1-□□ multi-function digital input parameters select the Drive or Bypass as the source.

**Setting 2: Serial Communications**

The serial communications protocol selected in parameter Z3-01 selects the Drive or Bypass as the source.

### ■ Z1-40: Auto Transfer Wait Time

Sets the length of time that the bypass controller will wait before switching to bypass when Auto Transfer is enabled and a drive fault is detected.

No.	Name	Setting Range	Default
Z1-40	Auto Transfer Wait Time	0.0 to 300.0 s	0.0 s

### ■ Z1-41: HAND Speed Reference Selection

Selects the frequency reference source when in HAND Mode.

**Note:** Parameter available in bypass controller software versions VST800298 and later.

No.	Name	Setting Range	Default
Z1-41	HAND Speed Reference Selection	0, 1	0

**Setting 0: Parameter Z1-09**

Parameter Z1-09 sets the frequency reference for the drive when in HAND Mode.

**Setting 1: Analog**

An analog input sets the frequency reference when in HAND Mode.

- Note:**
1. Set H3-02 to “1F - HAND Mode” when using Terminal A1 for HAND Mode frequency reference.
  2. Set H3-10 to “1F - HAND Mode” when using Terminal A2 for HAND Mode frequency reference.

**■ Z1-42: Bypass Device Type**

Selects the soft starter device type when used with a bypass.

No.	Name	Setting Range	Default
Z1-42	Bypass Device Type	0 to 2	0

**Note:** Parameter is available in bypass controller software versions VST800299 and later.

**Setting 0: Contactor**

Turns off the cabinet fans (if equipped) when in Bypass Mode.

**Setting 1: Soft Starter**

Cabinet fans (if equipped) will run in both Drive and Bypass Modes.

**Setting 2: SftStr Ramp Ctrl**

Allows "Soft Start" and "Soft Stop" operation if unit is equipped with a soft-starter. The soft-starter requires additional wiring and configuration.

- Note:**
1. Selecting this setting will disable Energy Savings Mode.
  2. This setting is available in bypass controller software versions VST800400 and later.

**■ Z1-43: Soft Start Time Delay**

Sets the delay time between closing bypass contactor K3 to energizing the soft starter.

This parameter is effective only when Z1-42 = 2.

No.	Name	Setting Range	Default
Z1-43	Soft Start Time Delay	0.0 to 60.0 s	2.0 s

**Note:** Parameter is available in bypass controller software versions VST800400 and later.

**■ Z1-44: Soft Start Ramp Down Timeout**

Set this parameter to a value longer than the longest expected ramp-down time of the soft-starter.

The bypass contactor opens and the motor coasts to a stop when the output current does not drop below 5% of the E2-01 level in the length of time set in this parameter.

This parameter is effective only when Z1-42 = 2.

No.	Name	Setting Range	Default
Z1-44	Soft Start Ramp Down Timeout	1.0 to 60.0 s	15.0 s

**Note:** Parameter is available in bypass controller software versions VST800400 and later.

**■ Z1-50: Bypass Unbalanced Current Detection Level**

Sets the current unbalance level between phases as a percentage of parameter E2-01 when operating in Bypass Mode. This function is used in conjunction with parameter Z1-51 to detect input or output phase loss during bypass operation.

The unbalance level is determined by measuring the RMS current in each of the output phases. The amount of current unbalance between the phases is calculated using the following formula:

$$\text{Unbalance Level} = (I_{(\max)} - I_{(\min)}) / I_{(\max)} \times 100\%$$

When the unbalance level exceeds the Z1-50 setting for longer than the time set to Z1-51, an “FB15 – Input Phase Loss” fault is triggered and the drive will coast to stop.

This parameter rarely needs to be changed.

**Note:** Parameter available in bypass controller software versions VST800298 and later.

No.	Name	Setting Range	Default
Z1-50	Bypass Unbalanced Current Detection Level	5.0 to 50.0%	25.0%

## 5.15 Z: Bypass Parameters

### ■ Z1-51: Bypass Unbalance Trip Time Detection Level

Sets the trip time for an unbalance condition when operating in Bypass Mode. This function is used in conjunction with parameter Z1-50 to detect input or output phase loss during bypass operation.

- Note:**
1. Parameter available in bypass controller software versions VST800298 and later.
  2. Setting this parameter to 0.0 will disable unbalance (bypass phase loss) protection.

No.	Name	Setting Range	Default
Z1-51	Bypass Unbalance Trip Time Detection Level	0.0 to 30.0 s	5.0 s

### ■ Z1-52: Bypass Phase Rotation

Input phase rotation is ignored when operating in Drive Mode. Input phase rotation determines motor direction when operating in Bypass Mode.

If input phase rotation is reversed and this parameter is set to 1, an “AL16 – Inp Phase Rotation” alarm will be displayed when operation starts in Bypass Mode and operation continues.

If input phase rotation is reversed and this parameter is set to 2, an “FB16 – Inp Phase Rotation” fault will be displayed when operation starts in Bypass Mode and the drive will coast to stop.

Controls the behavior of the bypass phase rotation detection when operating in Bypass Mode.

- Note:** Parameter available in bypass controller software versions VST800298 and later.

No.	Name	Setting Range	Default
Z1-52	Bypass Phase Rotation	0 to 2	0 <i>&lt;/i&gt;</i>

*</i>* Default is 1 in bypass controller software versions VST800299 and earlier.

**Setting 0: Disabled**

**Setting 1: Alarm**

**Setting 2: Fault**

### ■ Z1-53: Load Verification Fault Select

Enables and disables verification that the motor is running when commanded to run.

When this function is enabled and the bypass detects a loss of output current, such as an open external motor disconnect, or a zero frequency reference command for longer than 10 seconds, the bypass will display a “Load Lost” fault, coast to stop, and any digital output programmed to “Damper Act Out” (Z2-2□ = 20) will open.

The "Load Lost" fault is disabled during smoke purge operation.

- Note:** Parameter available in bypass controller software versions VST800400 and later.

No.	Name	Setting Range	Default
Z1-53	Load Verification Fault Select	0 to 1	0



Setting 0: Disabled

Setting 1: Enabled

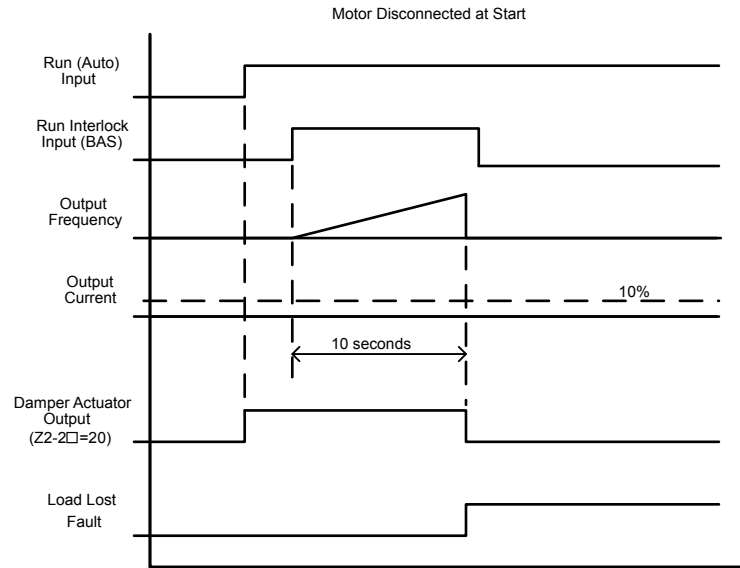

Figure 5.61 Motor Disconnected at Start

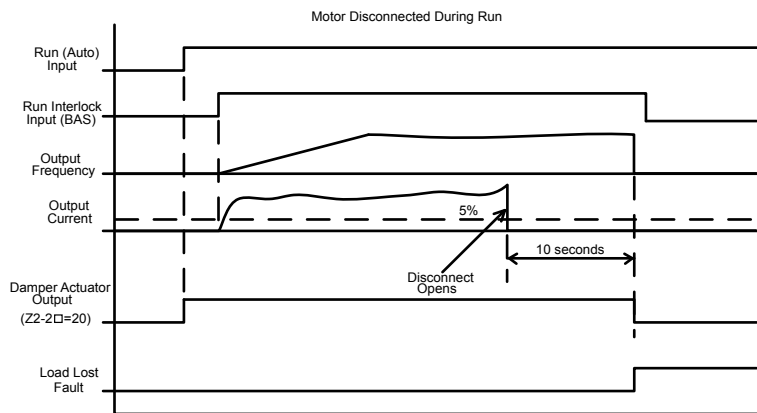

Figure 5.62 Motor Disconnected During Run

■ Z1-54: LCD Contrast Control

Sets the contrast of the LCD operator display on the bypass.

**Note:** Parameter available in bypass controller software versions VST800400 and later.

No.	Name	Setting Range	Default
Z1-54	LCD Contrast Control	1 to 5	3

■ Z1-55: Welded K3 Contactor Fault Select

Enables and disables monitoring of bypass contactor K3 for a "welded contactor" condition.

This detection is active when the bypass is taken out of bypass run mode or when power is first applied to the bypass package. The bypass will display an "FB18 - K3 Welded" fault upon detection of the condition. Cycle power to the bypass package to clear this fault.

**Note:** Parameter available in bypass controller software versions VST800400 and later.

No.	Name	Setting Range	Default
Z1-55	Welded K3 Contactor Fault Select	0, 1	0

## 5.15 Z: Bypass Parameters

Setting 0: Disabled

Setting 1: Enabled

### ■ Z1-60: Black Out Selection

Determines the bypass behavior when contactor voltage drops below Z1-29 setting.

**Note:** Parameter available in bypass controller software versions VST800401 and later.

No.	Name	Setting Range	Default
Z1-60	Black Out Selection	0, 1	0

Setting 0: Fault

Setting 1: Restart

### ■ Z1-61: Restart Delay

Sets the time delay for restart.

**Note:** Parameter available in bypass controller software versions VST800401 and later.

No.	Name	Setting Range	Default
Z1-61	Restart Delay	1 to 300 s	10 s

## ◆ Z2: Bypass Control Input/Output

### ■ Z2-01 to Z2-08: Digital Input 1 to 8 Function Select

No.	Name	Setting Range	Default
Z2-01	Digital Input 1 Function Select	0 to 36	21
Z2-02	Digital Input 2 Function Select	0 to 36	22
Z2-03	Digital Input 3 Function Select	0 to 36	23
Z2-04	Digital Input 4 Function Select	0 to 36	24
Z2-05	Digital Input 5 Function Select	0 to 36	25
Z2-06	Digital Input 6 Function Select	0 to 36	0
Z2-07	Digital Input 7 Function Select	0 to 36	0
Z2-08	Digital Input 8 Function Select	0 to 36	29

### ■ Bypass Digital Input Terminal Settings

Table 5.28 Bypass Digital Input Terminal Settings

Setting	Function	Page	Setting	Function	Page
0 <1>	Unused (Available for Serial Comms)	211	27	Motor OR Select	211
	<b>Note:</b> Multiple digital input terminals can be programmed for “Unused (Available for Serial Comms)” (Z2-0□ = 0). Set all other selections only once in parameters Z2-01 to Z2-08.		28	Motor AND Select	211
3	DRV Multi-Function Input S3 (H1-03 Setting)	211	29	Motor 1 Overload Contact	211
4	DRV Multi-Function Input S4 (H1-04 Setting)	211	30	Motor 2 Overload Contact	212
5	DRV Multi-Function Input S5 (H1-05 Setting)	211	31	HAND Select	212
6	DRV Multi-Function Input S6 (H1-06 Setting)	211	32	AUTO Select	212
7	DRV Multi-Function Input S7 (H1-07 Setting)	211	33	DRIVE/BYPASS Select	212
21	Run (AUTO Mode)	211	34	Fault Reset	212
22 <2>	Run Enable (Safety)	211	35	External Fault (EF0)	212
23	Run Interlock (BAS)	211	36	External Fault (EFB)	212
24	Remote Transfer to Bypass	211	37	Run Reverse (AUTO Mode)	212
25	Smoke Purge Bypass Run to Destruction	211	38 <3>	Fire Stat (Safety)	212
26	Smoke Purge Drive Run to Destruction at Smoke Purge Preset Speed	211	39 <3>	Freeze Stat (Safety)	212
			40 <3>	Smoke Alarm (Safety)	212
			41 <3>	Over Pressure (Safety)	212
			42 <3>	Low Suction (Safety)	212
			43 <3>	Vibration Switch (Safety)	212

- <1> Can be set to multiple digital input parameters simultaneously.
- <2> Can be set to multiple digital input parameters simultaneously in bypass controller software versions VST800298 and VST800299 only. The drive will run only when all digital inputs programmed for “22” are active.
- <3> Available in bypass controller software versions VST800400 and later.

#### Setting 0: Unused (Available for Serial Comms)

Input terminals programmed to this value will have no effect on the operation of the bypass package. It is possible, however, to read the status of the terminal over various serial communications protocols.

**Note:** Multiple digital input terminals can be programmed for “Unused (Available for Serial Comms)” (Z2-0□ = 0) in bypass controller software versions VST800298 and later. All other selections should only be set once in parameters Z2-01 to Z2-08.

#### Setting 3: DRV Multi-Function Input S3 (H1-03 Setting)

*Refer to H1-03 to H1-07: Functions for Terminals S3 to S7 on page 151* for available H1-03 multi-function input settings.

#### Setting 4: DRV Multi-Function Input S4 (H1-04 Setting)

*Refer to H1-03 to H1-07: Functions for Terminals S3 to S7 on page 151* for available H1-04 multi-function input settings.

#### Setting 5: DRV Multi-Function Input S5 (H1-05 Setting)

*Refer to H1-03 to H1-07: Functions for Terminals S3 to S7 on page 151* for available H1-05 multi-function input settings.

#### Setting 6: DRV Multi-Function Input S6 (H1-06 Setting)

*Refer to H1-03 to H1-07: Functions for Terminals S3 to S7 on page 151* for available H1-06 multi-function input settings.

#### Setting 7: DRV Multi-Function Input S7 (H1-07 Setting)

*Refer to H1-03 to H1-07: Functions for Terminals S3 to S7 on page 151* for available H1-07 multi-function input settings.

#### Setting 21: Run (AUTO Mode)

Starts and stops the bypass when Z1-08 is set to 1.

#### Setting 22: Run Enable (Safety)

Stops the drive from running regardless of Z1-08 setting. Z2-31 controls the message displayed on the HOA keypad when this input is open.

- Note:**
1. Multiple digital input terminals can be programmed for “Run Enable (Safety)” (Z2-0□ = 22) in bypass controller software versions VST800298 and VST800299 only. The drive will run only when all digital inputs programmed for “22” are active. All other selections should only be set once in parameters Z2-01 to Z2-08.
  2. Parameter Z2-31 available in bypass controller software versions VST800298 and VST800299 only.

#### Setting 23: Run Interlock (BAS)

Stops the drive and triggers alarm AL02. Use parameters Z1-13 and Z1-15 to modify Interlock settings.

#### Setting 24: Remote Transfer to Bypass

Stops the drive and turns on the bypass when a Run command is issued while in Drive Mode. The fault for this mode is controlled by parameter Z1-05. Parameter Z1-40 controls the length of time that the drive must be faulted before switching to Bypass Mode.

#### Setting 25: Smoke Purge Bypass Run to Destruction

Stops the drive, turns on the bypass, and triggers alarm AL03. The bypass runs continuously regardless of any faults or alarms.

#### Setting 26: Smoke Purge Drive Run to Destruction at Smoke Purge Preset Speed

Bypass controller will stay in this state even if the drive faults or is unavailable. The preset speed is equal to the value set to Z1-10.

#### Setting 27: Motor OR Select

2-Motor OR function; 0/1 for Motor 1/2. Behavior defined by Z1-11.

#### Setting 28: Motor AND Select

2-Motor AND function; 0/1 for 1/2 motor. If 1 motor, then look to Motor OR input for selected motor. Behavior defined by Z1-11.

#### Setting 29: Motor 1 Overload Contact

When input is open, declare an oL Fault, issue an EF0 fault to the drive, delay per EF0 Fault Delay Time (Z1-30), and open Bypass (K3) contactors.

## 5.15 Z: Bypass Parameters

---

### Setting 30: Motor 2 Overload Contact

When input is open, declare an oL Fault, issue an EF0 fault to the drive, delay per EF0 Fault Delay Time (Z1-30), and open Bypass (K3) contactors.

### Setting 31: HAND Select

When this is selected, the HAND function command will come from a digital input while the HAND key on the HOA operator will be ignored. If both HAND and AUTO functions are configured to come from digital inputs, the lack of both of these inputs being active will put the HOA function into the OFF state. The OFF key on the HOA operator will always place the HOA function to the OFF state.

### Setting 32: AUTO Select

When this is selected, the AUTO function command will come from a digital input while the AUTO key on the HOA operator will be ignored. If both HAND and AUTO functions are configured to come from digital inputs, the lack of both of these inputs being active will put the HOA function into the OFF state. The OFF key on the HOA operator will always place the HOA function to the OFF state.

### Setting 33: DRIVE/BYPASS Select

When this is selected, the DRIVE/BYPASS select function command will come from a digital input while the DRV/BYP key on the HOA operator will be ignored.

Input OFF: Drive Mode is selected.

Input ON: Bypass Mode is selected.

### Setting 34: Fault Reset

Resets any faults that are present.

### Setting 35: External Fault (EF0)

Issues external fault EF0 to the drive from the bypass. Use parameter Z1-30 to modify the fault delay time.

### Setting 36: External Fault (EFB)

Triggers external EFB on the bypass.

### Setting 37: Run Reverse (AUTO Mode)

Starts and stops the bypass in reverse when Z1-08 is set to 1.

### Setting 38: Fire Stat

Stops the drive from running and displays "Fire Stat" on the keypad regardless of Z1-08 setting.

**Note:** Available in bypass controller software versions VST800400 and later.

### Setting 39: Freeze Stat

Stops the drive from running and displays "Freeze Stat" on the keypad regardless of Z1-08 setting.

**Note:** Available in bypass controller software versions VST800400 and later.

### Setting 40: Smoke Alarm

Stops the drive from running and displays "Smoke Alarm" on the keypad regardless of Z1-08 setting.

**Note:** Available in bypass controller software versions VST800400 and later.

### Setting 41: Over Pressure

Stops the drive from running and displays "Over Pressure" on the keypad regardless of Z1-08 setting.

**Note:** Available in bypass controller software versions VST800400 and later.

### Setting 42: Low Suction

Stops the drive from running and displays "Low Suction" on the keypad regardless of Z1-08 setting.

**Note:** Available in bypass controller software versions VST800400 and later.

### Setting 43: Vibration Switch

Stops the drive from running and displays "Vibration Switch" on the keypad regardless of Z1-08 setting.

**Note:** Available in bypass controller software versions VST800400 and later.

### ■ Z2-09 to Z2-16: Digital Input 1 to 8 Invert Select

No.	Name	Setting Range	Default
Z2-09	Digital Input 1 Invert Select	0, 1	0
Z2-10	Digital Input 2 Invert Select	0, 1	0
Z2-11	Digital Input 3 Invert Select	0, 1	0
Z2-12	Digital Input 4 Invert Select	0, 1	0
Z2-13	Digital Input 5 Invert Select	0, 1	0
Z2-14	Digital Input 6 Invert Select	0, 1	0
Z2-15	Digital Input 7 Invert Select	0, 1	0
Z2-16	Digital Input 8 Invert Select	0, 1	0

### ■ Z2-23 to Z2-26: Digital Output 7 to 10 Function Select

No.	Name	Setting Range	Default
Z2-23	Digital Output 7 Function Select	0 to 24; 99	7
Z2-24	Digital Output 8 Function Select	0 to 24; 99	10
Z2-25	Digital Output 9 Function Select	0 to 24; 99	12
Z2-26	Digital Output 10 Function Select	0 to 24; 99	15

### ■ Bypass Digital Output Terminal Settings

Table 5.29 Bypass Digital Output Terminal Settings

Setting	Function	Setting	Function
0	Serial Comm Controlled	16	Drive Fault Active
1	K1 Drive Input Contactor	17	Bypass Fault Active
2	K2 Drive Output Contactor	18	Auto Transfer Active
3	K3 Bypass Contactor	19	Serial Run Command Active
4	K4 Motor 1 Select	20	Damper Actuator Output
5	K5 Motor 2 Select	21	ON Always
6	READY (Drive and Bypass)	22	Loss of Load Detected
7	RUN Active (Drive or Bypass)	23 <1>	Run Verify The digital output closes when the drive or bypass output current exceeds 10% of the value set in E2-01. The digital output opens when the drive or bypass output current falls below 5% of the value set in E2-01.
8	Drive RUN Active	24 <2>	Soft Start Run Controls the soft starter Run command to ramp down the soft starter before opening bypass contactor K3.
9	Bypass RUN Active	99	Not Used (Through Mode) This setting allows serial communications to control the output.
10	HAND Mode Active		
11	OFF Mode Active		
12	AUTO Mode Active		
13	Drive Mode Selected		
14	Bypass Mode Selected		
15	Drive or Bypass Fault Active		

<1> Available in bypass controller software versions VST800298 and later.

<2> Available in bypass controller software versions VST800400 and later.

### ■ Z2-31: Safety Open Message Selection

Sets the fault message displayed when an FB01 fault is triggered. This parameter also determines the text that is displayed on the top line of the HOA keypad.

**Note:** Parameter available in bypass controller software versions VST800298 and VST800299 only.

No.	Name	Setting Range	Default
Z2-31	Safety Open Message Selection	0 to 6	0

## 5.15 Z: Bypass Parameters

### Setting 0: Safety Open

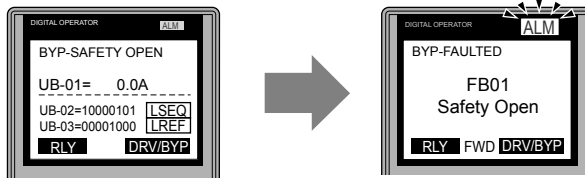

### Setting 1: Fire Stat

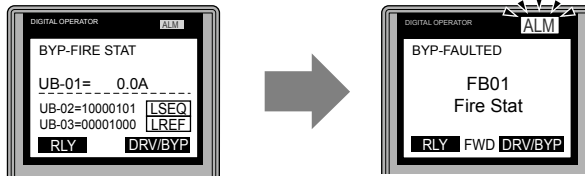

### Setting 2: Freeze Stat

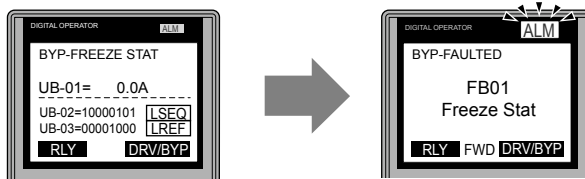

### Setting 3: Smoke Alarm

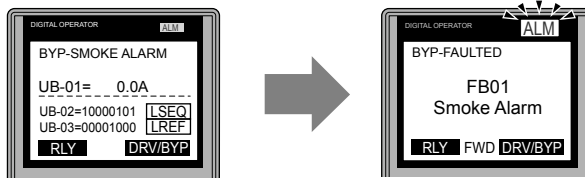

### Setting 4: Over Pressure

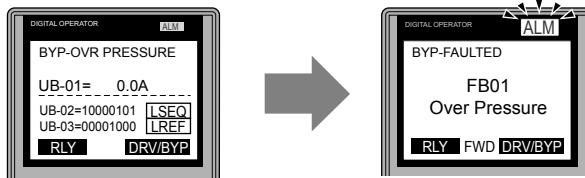

### Setting 5: Low Suction

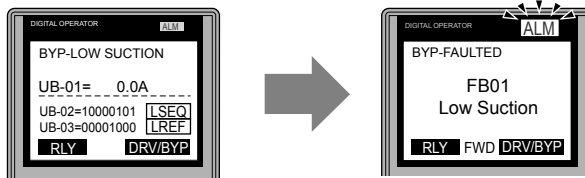

### Setting 6: Vibration Switch

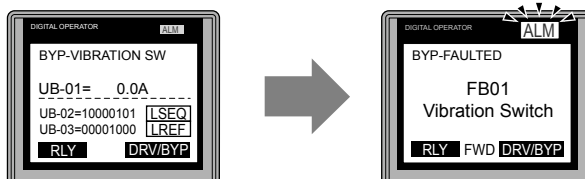

## ◆ Z3: Bypass Control Communication

### ■ Z3-01: Serial Communications Protocol Select

Selects the bypass serial communications protocol.

No.	Name	Setting Range	Default
Z3-01	Serial Communications Protocol Select	0 to 3	3

**Setting 0: Modbus**

**Setting 1: N2**

**Setting 2: P1**

**Setting 3: BACnet**

### ■ Z3-02: Serial Communications Node Select

Selects the bypass serial communications node address.

**Note:** Each slave must be assigned a unique slave address for serial communications to work properly. Slave addresses do not need to be assigned in sequential order, but no two slaves may share the same address.

No.	Name	Setting Range	Default
Z3-02	Serial Communications Node Select	0 to 127	1

## 5.15 Z: Bypass Parameters

### ■ Z3-03: Serial Communications Baud Rate Select

Selects the bypass serial communications speed.

Selecting settings 0, 1, or 2 will trigger an oPE29 error when using BACNet communication (Z3-01 = 3) in bypass controller software versions VST800400 and later.

No.	Name	Setting Range	Default
Z3-03	Serial Communications Baud Rate Select	0 to 8	3

**Setting 0: 1200 bps**

**Setting 1: 2400 bps**

**Setting 2: 4800 bps**

**Setting 3: 9600 bps**

**Setting 4: 19200 bps**

**Setting 5: 38400 bps**

**Setting 6: 57600 bps**

**Setting 7: 76800 bps**

**Setting 8: 115200 bps**

### ■ Z3-04: Serial Communications Parity Select

Selects the bypass serial communications parity. This setting is ignored when BACnet protocol is selected.

No.	Name	Setting Range	Default
Z3-04	Serial Communications Parity Select	0 to 2	0

**Setting 0: No Parity**

**Setting 1: Even Parity**

**Setting 2: Odd Parity**

### ■ Z3-05: Serial Communications Fault Select

Selects the action to take when a serial communications fault is detected. A serial communications fault is detected when after last communicating, no communications occurs within the time set to Z3-06.

No.	Name	Setting Range	Default
Z3-05	Serial Communications Fault Select	0 to 4	1

**Setting 0: Ignore**

**Setting 1: Alarm Only**

**Setting 2: Fault with EF0**

An EF0 fault will be sent to the drive.

**Setting 3: Fault with EF0 and Open Contactors**

An EF0 fault will be sent to the drive and the bypass contactor (K3) will be opened.

**Setting 4: Alarm and run at preset speed set in Z3-10**

Display AL14 alarm on operator.

### ■ Z3-06: Serial Communications Fault Time Select

Sets the time allowed to elapse since receiving serial communications before triggering a communications fault.

A value of 0.0 means to never time out.

No.	Name	Setting Range	Default
Z3-06	Serial Communications Fault Time Select	0.0 s to 99.9 s	2.0 s

### ■ Z3-07: Serial Communications Receive to Transmit Wait Time

Sets the time to delay a serial communications response to a serial communications command.

No.	Name	Setting Range	Default
Z3-07	Serial Communications Receive to Transmit Wait Time	0 to 99 ms	5 ms



### ■ Z3-08, Z3-09: BACnet Device Object Identifier

These parameters set the Instance Identifier of the BACnet Device Object, where Z3-08 is the least significant word and Z3-09 is the most significant word.

No.	Name	Setting Range	Default
Z3-08	BACnet Device Object Identifier 0	0 to FFFFH	1
Z3-09	BACnet Device Object Identifier 1	0 to 003FH	0

Example 1: Set Device Object Instance Identifier of “1234”.

1234 decimal is equal to 4D2H (hexadecimal).

Set Z3-08 to 4D2H and set Z3-09 to 0.

Example 2: Set Device Object Instance Identifier of “123456”.

123456 decimal is equal to 1E240H.

Set Z3-08 to D687H and set Z3-09 to 12H.

### ■ Z3-10: Cable Loss Pre-set Speed

Sets the frequency reference when a serial communications fault is detected and Z3-05 is set to 4.

No.	Name	Setting Range	Default
Z3-10	Cable Loss Pre-set Speed	0.0 to 60.0 Hz	0.0 Hz

### ■ Z3-11: Communication Fault Detection Selection

No.	Name	Setting Range	Default
Z3-11	Communication Fault Detection Selection	0 to 1	1

#### Setting 0: Disabled

Ignore setting in Z3-05.

#### Setting 1: Enabled

Behavior defined by Z3-05.

### ■ Z3-12: Network Digital Input Select

Determines whether the serial communication digital input simulation is active.

**Note:** Parameter available in bypass controller software versions VST800298 and later.

No.	Name	Setting Range	Default
Z3-12	Network Digital Input Select	0, 1	0

#### Setting 0: Disable

Serial communications physical digital inputs are ignored.

For MEMOBUS/Modbus (Z3-01 = 0): Command Register 8402H is disabled.

For Metasys N2 (Z3-01 = 1): Binary Outputs B05, B06, B07, B08, and B09 are disabled.

For P1 Apogee (Z3-01 = 2): Points LDO44, LDO45, LDO46, LDO47, and LDO48 are disabled.

For BACnet (Z3-01 = 3): BV72, BV73, BV74, BV75, BV76, BV77, BV78, and BV79 are disabled.

#### Setting 1: Enable

Physical digital inputs S1 to S8 are logically OR'd with the serial communications digital inputs.

**WARNING!** *Sudden Movement Hazard. Setting this parameter to 1 may cause the system to run unexpectedly or not stop when required even if the physical digital input is de-energized, resulting in death or serious injury. Clear all personnel from the drive, motor and machine area before applying power. Set this parameter to 0 to prevent serial communications from triggering undesired and unexpected system operation.*

## 5.15 Z: Bypass Parameters

### ■ Z3-13: BACNet Command Register Retention

**WARNING!** *Sudden Movement Hazard.* Setting this parameter to 2 or 3 will allow the bypass unit to start before receiving a valid network message. Clear all personnel from the drive, motor, and machine area before reapplying power. Failure to comply could result in injury to personnel.

Determines whether to restore the frequency reference, bypass command, or both upon the reapplication of power after losing power. The feature restores all bypass command register values except the fault reset bit.

Set Z1-06  $\neq$  0 or Z1-38 = 2 to allow the bypass to start running upon application of power.

- Note:**
1. Parameter is effective only when Z3-01 = 3 (Serial Communications Protocol Select = BACnet), Z1-07 = 2 (Speed Reference Select = Bypass Serial), and/or Z1-08 = 2 (Run Command Select = Bypass Serial).
  2. Parameter is available in bypass controller software versions VST800400 and later.

No.	Name	Setting Range	Default
Z3-13	BACNet Command Register Retention	0 to 3	0

#### Setting 0: Disabled

Reapplying power will not restore any BACNet objects.

#### Setting 1: Reference Only

Reapplying power restores the frequency reference object (AV2).

#### Setting 2: Run/Stop Only

Reapplying power restores various command objects including the Run commands. *Refer to BACNet Values Restored When Z3-13 = 2 or 3 on page 218* for a list of command objects.

#### Setting 3: Ref & Run/Stop

Reapplying power restores the frequency reference object (AV2) and various command objects. *Refer to BACNet Values Restored When Z3-13 = 2 or 3 on page 218* for a list of command objects.

Table 5.30 BACNet Values Restored When Z3-13 = 2 or 3

Object ID	Object Name
BV58	BYP Run Fwd CMD
BV59	BYP Run Rev CMD
BV61	BYP Xfer to BYP CMD
BV62	BYP Smok Prg BYP CMD
BV63	BYP Smok Prg DRV CMD
BV64	BYP Mtr OR Sel CMD
BV65	BYP Mtr AND Sel CMD
BV66	BYP HAND Select CMD
BV67	BYP Auto Select CMD
BV69	BYP BYPASS Sel CMD
BV71	BYP Ext Fault CMD (EFB)

### ◆ Z4: Ethernet Option Bypass Control

#### ■ Z4-01 to Z4-04: IP Address 1 to 4

Sets the network static IP address. Z4-01 is the most significant octet of the network static IP address; Z4-04 is the least significant.

No.	Parameter Name	Setting Range	Default
Z4-01	IP Address 1	0 to 255	192
Z4-02	IP Address 2		168
Z4-03	IP Address 3		1
Z4-04	IP Address 4		20

#### ■ Z4-05 to Z4-08: Subnet Mask 1 to 4

Sets the network static subnet mask. Z4-05 is the most significant octet of the network static subnet mask; Z4-08 is the least significant.

No.	Parameter Name	Setting Range	Default
Z4-05	Subnet Mask 1	0 to 255	255
Z4-06	Subnet Mask 2		255
Z4-07	Subnet Mask 3		255
Z4-08	Subnet Mask 4		0

#### ■ Z4-09 to Z4-12: Gateway Address 1 to 4

Sets the network gateway address. Z4-09 is the most significant octet of the network gateway address; Z4-12 is the least significant.

No.	Parameter Name	Setting Range	Default
Z4-09	Gateway Address 1	0 to 255	192
Z4-10	Gateway Address 2		168
Z4-11	Gateway Address 3		1
Z4-12	Gateway Address 4		1

#### ■ Z4-13: Address Startup Mode

Selects the option address setting method.

No.	Name	Setting Range	Default
Z4-13	Address Startup Mode	0 to 2	2

**Setting 0: User-Defined (Static IP)**

**Setting 1: BOOTP**

**Setting 2: DHCP**

#### ■ Z4-14: Duplex Mode Setting

No.	Name	Setting Range	Default
Z4-14	Duplex Mode Setting	0 to 2	1

**Setting 0: Forced Half Duplex**

**Setting 1: Auto Negotiate Duplex Mode and Communication Speed**

This setting also auto-negotiates Z4-15, Speed Mode Setting.

**Setting 2: Forced Full Duplex**

#### ■ Z4-15: Speed Mode Setting

No.	Name	Setting Range	Default
Z4-15	Speed Mode Setting	10, 100	10

**Setting 10: 10 Mbps**

**Setting 100: 100 Mbps**

#### ■ Z4-16: Timeout

Sets the Control Connection Timeout value for detection of communication loss in tenths of a second. A value of 0 disables the connection timeout.

Example: An entered value of 100 represents 10.0 seconds.

No.	Name	Setting Range	Default
Z4-16	Timeout	0 to 300 s	0 s

#### ■ Z4-17 to Z4-22: Scaling Factors

These parameters define scaling factors for drive monitors in the ODVA AC/DC Drive Object (Class 2AH), Instance 1, and the attribute given below:

Speed Scale is attribute 22

Current Scale is attribute 23

Torque Scale is attribute 24

## 5.15 Z: Bypass Parameters

Power Scale is attribute 26

Voltage Scale is attribute 27

Time Scale is attribute 28.

No.	Parameter Name	Setting Range	Default
Z4-17	Speed Scaling	-15 to 15	0
Z4-18	Current Scaling		0
Z4-19	Torque Scaling		0
Z4-20	Power Scaling		0
Z4-21	Voltage Scaling		0
Z4-22	Time Scaling		0

### ■ Z4-23 to Z4-32: Dynamic Output Assembly Parameters

Parameters used in Output Assembly 116. Each parameter contains a MEMOBUS/Modbus address. The value received for Output Assembly 116 will be written to this corresponding MEMOBUS/Modbus address. A MEMOBUS/Modbus address value of 0 means that the value received for Output Assembly 116 will not be written to any MEMOBUS/Modbus register.

No.	Parameter Name	Setting Range	Default
Z4-23	DOA116 1	0 to FFFFH	0
Z4-24	DOA116 2	0 to FFFFH	0
Z4-25	DOA116 3	0 to FFFFH	0
Z4-26	DOA116 4	0 to FFFFH	0
Z4-27	DOA116 5	0 to FFFFH	0
Z4-28	DOA116 6	0 to FFFFH	0
Z4-29	DOA116 7	0 to FFFFH	0
Z4-30	DOA116 8	0 to FFFFH	0
Z4-31	DOA116 9	0 to FFFFH	0
Z4-32	DOA116 10	0 to FFFFH	0

### ■ Z4-33 to Z4-42: Dynamic Input Assembly Parameters

Parameters used in Input Assembly 166. Each parameter contains a MEMOBUS/Modbus address. The value sent for Input Assembly 166 will be read from this corresponding MEMOBUS/Modbus address. A MEMOBUS/Modbus address value of 0 means that the value sent for Input Assembly 166 is not defined by the user, therefore the option default register value will be returned.

No.	Parameter Name	Setting Range	Default
Z4-33	DIA166 1	0 to FFFFH	0
Z4-34	DIA166 2	0 to FFFFH	0
Z4-35	DIA166 3	0 to FFFFH	0
Z4-36	DIA166 4	0 to FFFFH	0
Z4-37	DIA166 5	0 to FFFFH	0
Z4-38	DIA166 6	0 to FFFFH	0
Z4-39	DIA166 7	0 to FFFFH	0
Z4-40	DIA166 8	0 to FFFFH	0
Z4-41	DIA166 9	0 to FFFFH	0
Z4-42	DIA166 10	0 to FFFFH	0

# Diagnosics & Troubleshooting

---

This chapter provides descriptions of the Z1000 Bypass faults, alarms, errors, related displays, and guidance for troubleshooting. This chapter can also serve as a reference guide for tuning the Z1000 Bypass during a trial run.

<b>6.1</b>	<b>SECTION SAFETY.....</b>	<b>222</b>
<b>6.2</b>	<b>MOTOR PERFORMANCE FINE-TUNING.....</b>	<b>224</b>
<b>6.3</b>	<b>DRIVE ALARMS, FAULTS, AND ERRORS.....</b>	<b>225</b>
<b>6.4</b>	<b>FAULT DETECTION.....</b>	<b>229</b>
<b>6.5</b>	<b>ALARM DETECTION.....</b>	<b>245</b>
<b>6.6</b>	<b>PROGRAMMING ERRORS.....</b>	<b>252</b>
<b>6.7</b>	<b>AUTO-TUNING FAULT DETECTION.....</b>	<b>255</b>
<b>6.8</b>	<b>DIAGNOSING AND RESETTING FAULTS.....</b>	<b>257</b>
<b>6.9</b>	<b>TROUBLESHOOTING WITHOUT FAULT DISPLAY.....</b>	<b>259</b>

## 6.1 Section Safety

### DANGER

#### Electrical Shock Hazard

**Before servicing, disconnect all power to the equipment.** The internal capacitor remains charged even after the power supply is turned off. The charge indicator LED will extinguish when the DC bus voltage is below 50 Vdc. To prevent electric shock, wait for at least the time specified on the warning label, once all indicators are OFF, measure for unsafe voltages to confirm the drive is safe prior to servicing.

Failure to comply will result in death or serious injury.

### WARNING

#### Arc Flash Hazard

**It is possible that there is more than one source of power for equipment.**

Obey the requirements for Electrical Safety in the Workplace and local codes for safe work procedures and applicable personal protective equipment (PPE). Failure to obey can cause serious injury or death.

#### Electrical Shock Hazard

**Do not operate equipment with covers removed.**

Failure to comply could result in death or serious injury.

The diagrams in this section may illustrate drives without covers or safety shields to display details. Be sure to reinstall covers or shields before operating the drives and run the drives according to the instructions described in this manual.

**Always ground the motor-side grounding terminal.**

Improper equipment grounding could result in death or serious injury by contacting the motor case.

**Do not touch terminals before the capacitors have fully discharged.**

Failure to comply could result in death or serious injury.

Before servicing, disconnect all power to the equipment. The internal capacitor remains charged even after the power supply is turned off. The charge indicator LED will extinguish when the DC bus voltage is below 50 Vdc. To prevent electric shock, wait for at least the time specified on the warning label; after all indicators are OFF, measure for unsafe voltages to confirm the drive is safe prior to servicing.

**After blowing a fuse or tripping a GFCI, do not attempt to restart the drive or operate peripheral devices until five minutes pass and CHARGE lamp is OFF.**

Failure to comply could result in death, serious injury, and damage to the drive.

Check wiring and peripheral device ratings to identify the cause of trips.

Contact your supplier if the cause cannot be identified.

**Do not allow unqualified personnel to perform work on the drive.**

Failure to comply could result in death or serious injury.

Installation, maintenance, inspection and servicing must be performed only by authorized personnel familiar with installation, adjustment and maintenance of AC drives.

**Do not perform work on the drive while wearing loose clothing, jewelry, or without eye protection.**

Failure to comply could result in death or serious injury.

Remove all metal objects such as watches and rings, secure loose clothing and wear eye protection before beginning work on the drive.

**Do not remove covers or touch circuit boards while the power is on.**

Failure to comply could result in death or serious injury.

**⚠ WARNING****Fire Hazard**

**Tighten all terminal screws to the specified tightening torque.**

Loose electrical connections could result in death or serious injury by fire due to overheating of electrical connections.

**Do not use an improper voltage source.**

Failure to comply could result in death or serious injury by fire.

Verify that the rated voltage of the drive matches the voltage of the incoming drive input power before applying power.

**Do not use improper combustible materials.**

Failure to comply could result in death or serious injury by fire.

Attach the drive to metal or other noncombustible material.

**NOTICE**

**Observe proper electrostatic discharge procedures (ESD) when handling the drive and circuit boards.**

Failure to comply may result in ESD damage to the drive circuitry.

**Never connect or disconnect the motor from the drive while the drive is outputting voltage.**

Improper equipment sequencing could result in damage to the drive.

**Do not use unshielded cable for control wiring.**

Failure to comply may cause electrical interference resulting in poor system performance. Use shielded twisted-pair wires and ground the shield to the ground terminal of the drive.

**Do not modify the drive circuitry.**

Failure to comply could result in damage to the drive and will void warranty.

Yaskawa is not responsible for modification of the product made by the user.

**Check all the wiring after installing the drive and connecting other devices to ensure that all connections are correct.**

Failure to comply could result in damage to the drive.

## 6.2 Motor Performance Fine-Tuning

This section offers helpful information for counteracting oscillation, hunting, and other problems that occur while performing a trial run. Refer to the appropriate control method in this section.

**Note:** This section describes commonly edited parameters that may be set incorrectly. Consult Yaskawa for more information on detailed settings and for fine-tuning the drive.

### ◆ Fine-Tuning V/f Control

**Table 6.1 Parameters for Fine-Tuning Performance in V/f**

Problem	Parameter No.	Corrective Action	Default	Suggested Setting
Motor hunting and oscillation at speeds between 10 and 40 Hz	Hunting Prevention Gain (n1-02)	<ul style="list-style-type: none"> <li>Reduce the setting if insufficient motor torque relative to the size of the load causes hunting.</li> <li>Increase the setting when motor hunting and oscillation occur with a light load.</li> <li>Reduce the setting if hunting occurs when using a motor with a relatively low inductance, such as a high-frequency motor or a motor with a larger frame size.</li> </ul>	1.00	0.10 to 2.00
<ul style="list-style-type: none"> <li>Motor noise</li> <li>Motor hunting and oscillation at speeds up to 40 Hz</li> </ul>	Carrier Frequency Selection (C6-02)	<ul style="list-style-type: none"> <li>Increase the carrier frequency If the motor noise is too loud.</li> <li>Lower the carrier frequency when motor hunting and oscillation occur at speeds up to 40 Hz.</li> <li>The default setting for the carrier frequency depends on the drive capacity (o2-04).</li> </ul>	1 (2 kHz)	1 to max. setting
<ul style="list-style-type: none"> <li>Poor torque or speed response</li> <li>Motor hunting and oscillation</li> </ul>	Torque Compensation Primary Delay Time (C4-02)	<ul style="list-style-type: none"> <li>Reduce the setting if motor torque and speed response are too slow.</li> <li>Increase the setting if motor hunting and oscillation occur.</li> </ul>	Depends on o2-04, Drive Model Selection	100 to 1000 ms
<ul style="list-style-type: none"> <li>Poor motor torque at speeds below 10 Hz</li> <li>Motor hunting and oscillation</li> </ul>	Torque Compensation Gain (C4-01)	<ul style="list-style-type: none"> <li>Increase the setting if motor torque is insufficient at speeds below 10 Hz.</li> <li>Reduce the setting if motor hunting and oscillation with a relatively light load.</li> </ul>	1.00	0.50 to 1.50
<ul style="list-style-type: none"> <li>Poor motor torque at low speeds</li> <li>Motor instability at motor start</li> </ul>	V/f Pattern Selection (E1-03)	<ul style="list-style-type: none"> <li>Increase the setting if motor torque is insufficient at speeds below 10 Hz.</li> <li>Reduce the setting If motor instability occurs at motor start.</li> <li>Set E1-03 to a pattern that fits the application.</li> </ul>	Depends on o2-04	Default setting $\pm 5$ V

### ◆ Parameters to Minimize Motor Hunting and Oscillation

In addition to the parameters discussed in [Table 6.1](#), parameters in [Table 6.2](#) indirectly affect motor hunting and oscillation.

**Table 6.2 Parameters that Affect Control Performance in Applications**

Name (Parameter No.)	Application
<b>Accel/Decel Time (C1-01 through C1-11)</b>	Adjusting accel and decel times will affect the torque presented to the motor during acceleration or deceleration.
<b>S-Curve Characteristics (C2-01 and C2-02)</b>	Prevents shock at the beginning and end of acceleration and deceleration.
<b>Jump Frequency (d3-01 through d3-04)</b>	Skips over the resonant frequencies of connected machinery.
<b>Analog Filter Time Constant (H3-13)</b>	Prevents fluctuation in the analog input signal due to noise.
<b>Stall Prevention (L3-01 through L3-06, L3-11)</b>	<ul style="list-style-type: none"> <li>Prevents motor speed loss and overvoltage when the load is too heavy or during sudden acceleration/ deceleration.</li> <li>Adjustment is not normally necessary because Stall Prevention is enabled as a default.</li> </ul>



## 6.3 Drive Alarms, Faults, and Errors

### ◆ Types of Alarms, Faults, and Errors

Check the HOA keypad for information about possible faults if the drive or motor fails to operate. *Refer to Using the HOA Keypad on page 91.*

If problems occur that are not covered in this manual, contact the nearest Yaskawa representative with the following information:

- Z1000 Bypass model (located on nameplate inside bypass enclosure)
- Software version (UB-18)
- Date of purchase
- Description of the problem

**Table 6.3** contains descriptions of the various types of alarms, faults, and errors that may occur while operating the drive.

**Table 6.3 Types of Alarms, Faults, and Errors**

Type	Drive Response
<b>Faults</b>	<p>When the Z1000 Bypass detects a fault:</p> <ul style="list-style-type: none"> <li>• The HOA keypad displays text indicating the specific fault and the ALM indicator LED remains lit until the fault is reset.</li> <li>• The fault interrupts drive output and the motor coasts to a stop.</li> <li>• Some faults allow the user to select the stopping method when the fault occurs.</li> <li>• Fault output terminals TB1 11 and 12 will close, and TB1 10 and 11 will open.</li> </ul> <p>The Z1000 Bypass will remain inoperable until the fault is cleared. <i>Refer to Fault Reset Methods on page 258.</i></p>
<b>Minor Faults and Alarms</b>	<p>When the drive detects an alarm or a minor fault:</p> <ul style="list-style-type: none"> <li>• The HOA keypad displays text indicating the specific alarm or minor fault, and the ALM indicator LED flashes.</li> <li>• The drive continues running the motor, although some alarms allow the user to select a stopping method when the alarm occurs.</li> <li>• The HOA keypad displays text indicating a specific alarm and the ALM indicator LED flashes.</li> </ul> <p>Remove the cause of the problem to reset a minor fault or alarm.</p>
<b>Operation Errors</b>	<p>An operation error occurs when parameter settings conflict or do not match hardware settings (such as with an option card). When the drive detects an operation error:</p> <ul style="list-style-type: none"> <li>• The HOA keypad displays text indicating the specific error.</li> <li>• Multi-function contact outputs do not operate.</li> </ul> <p>The Z1000 Bypass will not operate the motor until the error has been reset. Correct the settings that caused the operation error to clear the error.</p>
<b>Tuning Errors</b>	<p>Tuning errors occur while performing Auto-Tuning. When the drive detects a tuning error:</p> <ul style="list-style-type: none"> <li>• The HOA keypad displays text indicating the specific error.</li> <li>• Multi-function contact outputs do not operate.</li> <li>• Motor coasts to stop.</li> </ul> <p>Remove the cause of the error and repeat the Auto-Tuning process.</p>

### ◆ Alarm and Error Displays

#### ■ Faults

**Table 6.4** gives an overview of possible fault codes. Conditions such as overvoltages can trip faults and alarms. It is important to distinguish between faults and alarms to determine the proper corrective actions.

When the drive detects a fault, the ALM indicator LED lights, the fault code appears on the HOA keypad, and the fault contact DO-10 triggers. An alarm is present if the ALM LED blinks and the fault code on the HOA keypad flashes. *Refer to [Minor Faults and Alarms on page 227](#)* for a list of alarm codes.

**Table 6.4** Fault Displays

HOA Keypad Display	Name	Page	HOA Keypad Display	Name	Page
bAT	HOA Keypad Battery Voltage Low	<a href="#">229</a>	FB21 <4>	Freeze Stat (Safety)	<a href="#">236</a>
bUS	Option Communication Error	<a href="#">229</a>	FB22 <4>	Smoke Alarm (Safety)	<a href="#">236</a>
CE	MEMOBUS/Modbus Communication Error	<a href="#">229</a>	FB23 <4>	Over Pressure (Safety)	<a href="#">236</a>
CoF	Current Offset Fault	<a href="#">229</a>	FB24 <4>	Low Suction (Safety)	<a href="#">236</a>
CPF00, CPF01 <1>	Control Circuit Error	<a href="#">230</a>	FB25 <4>	Vibration Switch (Safety)	<a href="#">236</a>
CPF02	A/D Conversion Error	<a href="#">230</a>	FB26 <4>	Option On Drive (Safety)	<a href="#">235</a>
CPF03	Control Board Connection Error	<a href="#">230</a>	FbH	Excessive PI Feedback	<a href="#">237</a>
CPF06	EEPROM Memory Data Error	<a href="#">230</a>	FbL	PI Feedback Loss	<a href="#">237</a>
CPF07, CPF08	Terminal Board Connection Error	<a href="#">230</a>	GF	Ground Fault	<a href="#">237</a>
CPF20, CPF21 <2>	Control Circuit Error	<a href="#">231</a>	LF	Output Phase Loss	<a href="#">237</a>
CPF22	Hybrid IC Error	<a href="#">231</a>	LF2	Current Imbalance	<a href="#">238</a>
CPF23	Control Board Connection Error	<a href="#">231</a>	nSE	Node Setup Error	<a href="#">238</a>
CPF24	Drive Unit Signal Fault	<a href="#">231</a>	oC	Overcurrent	<a href="#">238</a>
EF0	Option Card External Fault	<a href="#">231</a>	oFA00	Option Card Connection Error (CN5)	<a href="#">239</a>
Err	EEPROM Write Error	<a href="#">231</a>	oH	Heatsink Overheat	<a href="#">239</a>
FAn	Internal Fan Fault	<a href="#">231</a>	oH1	Heatsink Overheat	<a href="#">239</a>
Fn1	External Fan Fault	<a href="#">236</a>	oH3	Motor Overheat Alarm (PTC input)	<a href="#">239</a>
FB01	Safety Open	<a href="#">232</a>	oH4	Motor Overheat Fault (PTC input)	<a href="#">240</a>
FB02	BAS Interlock Open Time Out	<a href="#">232</a>	oL1	Motor Overload	<a href="#">240</a>
FB03	External Fault Bypass (EFB)	<a href="#">232</a>	oL2	Drive Overload	<a href="#">241</a>
FB05	Motor Overload	<a href="#">232</a>	oL3	Overtorque Detection 1	<a href="#">241</a>
FB06	External Motor 1 Overload	<a href="#">233</a>	oL7	High Slip Braking oL	<a href="#">241</a>
FB07	External Motor 2 Overload	<a href="#">233</a>	oPr	Operator Connection Fault	<a href="#">241</a>
FB08	Phase Loss Brownout	<a href="#">233</a>	ov	Overvoltage	<a href="#">241</a>
FB09	Phase Loss Blackout	<a href="#">234</a>	ov2	Overvoltage 2	<a href="#">242</a>
FB10	No Drive Comms	<a href="#">234</a>	PF	Input Phase Loss	<a href="#">242</a>
FB11	Bypass Board Hardware Error	<a href="#">234</a>	SEr	Too Many Speed Search Restarts	<a href="#">243</a>
FB12	Option Board Comms	<a href="#">234</a>	STo	Pull-Out Detection	<a href="#">243</a>
FB13	Loss of Load	<a href="#">234</a>	TdE	Time Data Error	<a href="#">243</a>
FB14	Serial Communications Fault	<a href="#">234</a>	TIM	Time Not Set	<a href="#">243</a>
FB15 <3>	Input Phase Loss	<a href="#">235</a>	UL3	Undertorque Detection 1	<a href="#">243</a>
FB16 <3>	Input Phase Rotation	<a href="#">235</a>	UL6	Motor Underload	<a href="#">243</a>
FB17 <4>	Load Lost	<a href="#">235</a>	Uv1	Undervoltage	<a href="#">244</a>
FB18 <4>	K3 Welded	<a href="#">235</a>	Uv2	Control Power Supply Undervoltage	<a href="#">244</a>
FB19 <4>	Duplicate Input	<a href="#">235</a>	Uv3	Soft Charge Circuit Fault	<a href="#">244</a>
FB20 <4>	Fire Stat (Safety)	<a href="#">235</a>	voF	Output Voltage Detection Fault	<a href="#">244</a>

<1> Displayed as CPF00 when occurring at drive power up. When a fault occurs after successfully starting the drive, the display will show CPF01.

<2> Displayed as CPF20 when occurring at drive power up. When a fault occurs after successfully starting the drive, the display will show CPF21.

<3> Available in bypass controller software versions VST800298 and later.

<4> Available in bypass controller software versions VST800400 and later.

**■ Minor Faults and Alarms**

Refer to [Table 6.5](#) for an overview of possible alarm codes. Conditions such as overvoltages can trip faults and alarms. It is important to distinguish between faults and alarms to determine the proper corrective actions.

When the drive detects an alarm, the ALM indicator LED blinks and the alarm code display flashes. A fault (not an alarm) is present if the ALM LED lights without blinking. [Refer to Faults on page 226](#) for information on fault codes.

**Table 6.5 Minor Fault and Alarm Displays**

HOA Keypad Display	Name	Page	HOA Keypad Display	Name	Page
AL02	BAS Interlock Open	<a href="#">245</a>	LT-1	Cooling Fan Maintenance Time	<a href="#">248</a>
AL03	Smoke Purge in Bypass	<a href="#">245</a>	LT-2	Capacitor Maintenance Time	<a href="#">248</a>
AL04	Smoke Purge in Drive	<a href="#">245</a>	LT-3	Soft Charge Bypass Relay Maintenance Time	<a href="#">249</a>
AL09 <1>	Run Active during Restart Delay	<a href="#">245</a>	oH	Heatsink Overheat	<a href="#">249</a>
AL13	Loss of Load	<a href="#">245</a>	oH2	Drive Overheat	<a href="#">249</a>
AL14	Serial Communications Fault	<a href="#">245</a>	oH3	Motor Overheat	<a href="#">249</a>
AL16 <2>	Input Phase Rotation	<a href="#">246</a>	oL3	Overtorque 1	<a href="#">249</a>
bAT	HOA Keypad Battery Voltage Low	<a href="#">229</a>	ov	Overvoltage	<a href="#">250</a>
bb	Drive Baseblock	<a href="#">246</a>	PASS	MEMOBUS/Modbus Test Mode Complete	<a href="#">250</a>
bUS	Option Card Communications Error	<a href="#">246</a>	SAFE	Customer Safety	<a href="#">250</a>
CE	MEMOBUS/Modbus Communication Error	<a href="#">247</a>	SE	MEMOBUS/Modbus Test Mode Fault	<a href="#">250</a>
CrST	Cannot Reset	<a href="#">247</a>	TdE	Time Data Error	<a href="#">243</a>
EF	Run Command Input Error	<a href="#">247</a>	TIM	Time Not Set	<a href="#">243</a>
EF0	Option Card External Fault	<a href="#">247</a>	UL3	Undertorque 1	<a href="#">250</a>
FAn	Internal Fan Fault	<a href="#">231</a>	UL6	Undertorque 6	<a href="#">251</a>
FbH	Excessive PI Feedback	<a href="#">247</a>	Uv	Undervoltage	<a href="#">251</a>
FbL	PI Feedback Loss	<a href="#">248</a>	voF	Output Voltage Detection Fault	<a href="#">251</a>
Fn1	External Fan Fault	<a href="#">236</a>	WrUn	Waiting for Run	<a href="#">251</a>
inTLK <3>	Interlock Open	<a href="#">248</a>			

<1> Available in bypass controller software versions VST800401 and later.

<2> Available in bypass controller software versions VST800298 and later.

<3> ALM LED will not blink.

**■ Operation Errors**

**Table 6.6 Operation Error Displays**

HOA Keypad Display	Name	Page	HOA Keypad Display	Name	Page
oPE01	Drive Unit Setting Error	<a href="#">252</a>	oPE09	PI Control Selection Error	<a href="#">253</a>
oPE02	Parameter Setting Range Error	<a href="#">252</a>	oPE10	V/f Data Setting Error	<a href="#">253</a>
oPE03	Multi-Function Input Setting Error	<a href="#">252</a>	oPE11	Carrier Frequency Setting Error	<a href="#">253</a>
oPE05	Run Command Selection Error	<a href="#">253</a>	oPE28	Sequence Timer Error	<a href="#">254</a>
oPE07	Multi-Function Analog Input Selection Error	<a href="#">253</a>	oPE29	Baud Rate Setting Error	<a href="#">254</a>

**■ Auto-Tuning Errors**

**Table 6.7 Auto-Tuning Error Displays**

HOA Keypad Display	Name	Page	HOA Keypad Display	Name	Page
End3	Rated Current Setting Alarm	<a href="#">255</a>	Er-02	Alarm	<a href="#">255</a>
End4	Adjusted Slip Value Fell Below Lower Limit	<a href="#">255</a>	Er-03	OFF Button Input	<a href="#">256</a>
End5	Resistance Between Lines Error	<a href="#">255</a>	Er-04	Line-to-Line Resistance Error	<a href="#">256</a>
End7	No-Load Current Alarm	<a href="#">255</a>	Er-05	No-Load Current Error	<a href="#">256</a>
Er-01	Motor Data Error	<a href="#">255</a>	Er-08	Rated Slip Error	<a href="#">256</a>

### 6.3 Drive Alarms, Faults, and Errors

---

HOA Keypad Display	Name	Page	HOA Keypad Display	Name	Page
Er-09	Acceleration Error	<a href="#">256</a>	Er-12	Current Detection Error	<a href="#">256</a>

## 6.4 Fault Detection

### ◆ Fault Displays, Causes, and Possible Solutions

Faults are detected for drive protection, and cause the drive to stop while triggering the fault output terminal TB1 10, 11, and 12. Remove the cause of the fault and manually clear the fault before attempting to run the drive again.

Table 6.8 Detailed Fault Displays, Causes, and Possible Solutions

HOA Keypad Display	Fault Name
bAT	HOA Keypad Battery Voltage Low
Cause	Possible Solution
The HOA keypad battery is low	Replace the HOA keypad battery.

HOA Keypad Display	Fault Name
bUS	Option Communication Error
	<ul style="list-style-type: none"> <li>The connection was lost after establishing initial communication.</li> <li>Only detected when the run command frequency reference is assigned to an option card.</li> </ul>
Cause	Possible Solution
No signal was received from the PLC	<ul style="list-style-type: none"> <li>Check for faulty wiring.</li> </ul>
Faulty communications wiring or an existing short circuit	<ul style="list-style-type: none"> <li>Correct the wiring.</li> <li>Check for disconnected cables and short circuits and repair as needed.</li> </ul>
Communication data error occurred due to noise	<ul style="list-style-type: none"> <li>Check the various options available to minimize the effects of noise.</li> <li>Counteract noise in the control circuit, main circuit, and ground wiring.</li> <li>Ensure that other equipment such as switches or relays do not cause noise. Use surge absorbers if necessary.</li> <li>Use only recommended cables or other shielded line. Ground the shield on the controller side or the drive input power side.</li> <li>Separate all communication wiring from drive power lines.</li> </ul>
The option card is damaged	Replace the option card if there are no problems with the wiring and the error continues to occur.
The option card is not properly connected to the drive	<ul style="list-style-type: none"> <li>The connector pins on the option card do not line up properly with the connector pins on the drive.</li> <li>Reinstall the option card.</li> </ul>

HOA Keypad Display	Fault Name
CE	MEMOBUS/Modbus Communication Error
	Control data was not received for the CE detection time set to H5-09.
Cause	Possible Solution
Faulty communications wiring or an existing short circuit	<ul style="list-style-type: none"> <li>Check for faulty wiring.</li> <li>Correct the wiring.</li> <li>Check for disconnected cables and short circuits and repair as needed.</li> </ul>
Communication data error occurred due to noise	<ul style="list-style-type: none"> <li>Check the various options available to minimize the effects of noise.</li> <li>Counteract noise in the control circuit, main circuit, and ground wiring.</li> <li>Use only recommended cables or other shielded line. Ground the shield on the controller side or the drive input power side.</li> <li>Ensure that other equipment such as switches or relays do not cause noise. Use surge suppressors if required.</li> <li>Separate all communication wiring from drive power lines.</li> </ul>
Communications between the bypass controller and the drive have stopped for longer than 2 seconds.	<p>Check the communication cable, terminal CN6 on the bypass board, and terminals R+, R-, S+, and S- on the drive terminal strip.</p> <p><b>Note:</b> This fault may also occur when the bypass is initialized by setting Z1-01 to 1, 2, or 3. Cycle power on the bypass to clear.</p>

HOA Keypad Display	Fault Name
CoF	Current Offset Fault
Cause	Possible Solution

## 6.4 Fault Detection

HOA Keypad Display	Fault Name
The drive tried to adjust the current offset value beyond the allowable range. This is due to residual induction current in the motor (e.g., during sudden deceleration or when coasting) when the drive attempted to start the motor.	<ul style="list-style-type: none"> <li>• Create a motor restart sequence that allows enough time for residual induction voltage to dissipate.</li> <li>• Enable Speed Search at start (b3-01 = 1).</li> </ul>
The current sensor in the drive is damaged	If the problem continues, replace the control board or the entire drive. Contact Yaskawa or a Yaskawa representative for instructions on replacing the control board.

HOA Keypad Display	Fault Name
CPF00 or CPF01	Control Circuit Error
<b>Cause</b>	<b>Possible Solution</b>
There is a self-diagnostic error in the control circuit	<ul style="list-style-type: none"> <li>• Cycle power to the drive.</li> <li>• If the problem continues, replace the control board or the entire drive. Contact Yaskawa or a Yaskawa representative for instructions on replacing the control board.</li> </ul>
Connector on the operator is damaged	Replace the operator.

HOA Keypad Display	Fault Name
CPF02	A/D Conversion Error An A/D conversion error or control circuit error occurred.
<b>Cause</b>	<b>Possible Solution</b>
Control circuit is damaged	<ul style="list-style-type: none"> <li>• Cycle power to the drive.</li> <li>• If the problem continues, replace the control board or the entire drive. Contact Yaskawa or a Yaskawa representative for instructions on replacing the control board.</li> </ul>

HOA Keypad Display	Fault Name
CPF03	Control Board Connection Error Connection error between the control board and the drive
<b>Cause</b>	<b>Possible Solution</b>
There is a connection error	<ul style="list-style-type: none"> <li>• Turn off the power and check the connection between the control board and the drive.</li> <li>• If the problem continues, replace the control board or the entire drive. Contact Yaskawa or a Yaskawa representative for instructions on replacing the control board.</li> </ul>
Drive fails to operate properly due to noise interference	<ul style="list-style-type: none"> <li>• Check the various options available to minimize the effects of noise.</li> <li>• Counteract noise in the control circuit, main circuit, and ground wiring.</li> <li>• Use only recommended cables or other shielded line. Ground the shield on the controller side or the drive input power side.</li> <li>• Ensure that other equipment such as switches or relays do not cause noise. Use surge suppressors if required.</li> <li>• Separate all communication wiring from drive power lines.</li> </ul>

HOA Keypad Display	Fault Name
CPF06	EEPROM Memory Data Error Error in the data saved to EEPROM
<b>Cause</b>	<b>Possible Solution</b>
There is an error in EEPROM control circuit	<ul style="list-style-type: none"> <li>• Turn off the power and check the connection between the control board and the drive.</li> <li>• If the problem continues, replace the control board or the entire drive. Contact Yaskawa or a Yaskawa representative for instructions on replacing the control board.</li> </ul>
The power supply was switched off while parameters were being saved to the drive	Reinitialize the drive using parameter A1-03.

HOA Keypad Display	Fault Name
CPF07	Terminal Board Connection Error
CPF08	
<b>Cause</b>	<b>Possible Solution</b>
There is a faulty connection between the terminal board and the control board	<ul style="list-style-type: none"> <li>• Turn off the power and check the connection between the control board and the drive.</li> <li>• If the problem continues, replace the control board or the entire drive. Contact Yaskawa or a Yaskawa representative for instructions on replacing the control board.</li> </ul>

HOA Keypad Display	Fault Name
CPF20 or CPF21	Control Circuit Error
<b>Cause</b>	<b>Possible Solution</b>
Hardware is damaged	<ul style="list-style-type: none"> <li>• Cycle power to the drive.</li> <li>• If the problem continues, replace the control board or the entire drive. Contact Yaskawa or a Yaskawa representative for instructions on replacing the control board.</li> </ul>

HOA Keypad Display	Fault Name
CPF22	Hybrid IC Failure
<b>Cause</b>	<b>Possible Solution</b>
Hybrid IC failure on the power board	<ul style="list-style-type: none"> <li>• Cycle power to the drive.</li> <li>• If the problem continues, replace the power board or the entire drive. Contact Yaskawa or a Yaskawa representative for instructions on replacing the power board.</li> </ul>

HOA Keypad Display	Fault Name
CPF23	Control Board Connection Error
	Connection error between the control board and the drive
<b>Cause</b>	<b>Possible Solution</b>
Hardware is damaged	<ul style="list-style-type: none"> <li>• Turn off the power and check the connection between the control board and the drive.</li> <li>• If the problem continues, replace the control board or the entire drive. Contact Yaskawa or a Yaskawa representative for instructions on replacing the control board.</li> </ul>

HOA Keypad Display	Fault Name
CPF24	Drive Unit Signal Fault
	The drive capacity cannot be detected correctly (drive capacity is checked when the drive is powered up).
<b>Cause</b>	<b>Possible Solution</b>
Hardware is damaged	If the problem continues, replace the control board or the entire drive. Contact Yaskawa or a Yaskawa representative for instructions on replacing the control board.

HOA Keypad Display	Fault Name
EF0	Option Card External Fault
	An external fault condition is present.
<b>Cause</b>	<b>Possible Solution</b>
An external fault was received from the serial communications network	<ul style="list-style-type: none"> <li>• Remove the cause of the external fault.</li> <li>• Remove the external fault input from the controller.</li> <li>• Verify that the controller program is correct.</li> </ul>
An external fault (EF0) digital input became active.	Remove the cause of the external fault.
Faults FB01 to FB09, FB13, or FB14 were declared by the bypass controller.	Remove the cause of the bypass controller fault.

HOA Keypad Display	Fault Name
Err	EEPROM Write Error
	Data cannot be written to the EEPROM
<b>Cause</b>	<b>Possible Solution</b>
Noise has corrupted data while writing to the EEPROM	<ul style="list-style-type: none"> <li>• Press “ENTER” on the HOA keypad.</li> <li>• Correct the parameter setting.</li> <li>• Cycle power to the drive.</li> <li>• If the problem continues, replace the control board or the entire drive. Contact Yaskawa or a Yaskawa representative for instructions on replacing the control board.</li> </ul>
Hardware problem	If the problem continues, replace the control board or the entire drive. Contact Yaskawa or a Yaskawa representative for instructions on replacing the control board.

HOA Keypad Display	Fault Name
FAn	Internal Fan Fault
	Fan or magnetic contactor failure

## 6.4 Fault Detection

HOA Keypad Display	Fault Name
Cause	Possible Solution
Internal cooling fan has malfunctioned	<ul style="list-style-type: none"> <li>• Cycle power to the drive.</li> <li>• Check for fan operation.</li> <li>• Verify the cumulative operation time of the fan with monitor U4-03, and verify the cumulative operation time of the fan maintenance timer with U4-04.</li> <li>• If the cooling fan has exceeded its expected performance life or is damaged in any other way, follow the replacement instructions in the <a href="#">Periodic Inspection &amp; Maintenance</a> chapter.</li> </ul>
Fault detected in the internal cooling fan or magnetic contactor to the power supply	<ul style="list-style-type: none"> <li>• Cycle power to the drive.</li> <li>• If the fault continues to occur, replace the power board/gate drive board or the entire drive.</li> <li>• Contact Yaskawa or a Yaskawa representative for instructions on replacing the power board/gate drive board.</li> </ul>

HOA Keypad Display	Fault Name
FB01	Safety Open <1> <b>Note:</b> A fault reset is not required. Bypass contactor K3 is opened.
Cause	Possible Solution
The digital input set to Safety open is open	<ul style="list-style-type: none"> <li>• Install a NC safety circuit between DI-□ and IG-24 on PCB A2</li> <li>• Install a jumper between DI-2 and IG-24 on PCB A2. Use this method if a safety circuit will be added in the future or is no safety circuit will be used at all.</li> </ul>

<1> Available in bypass controller software versions VST800298 and VST800299. Parameter Z2-31, Safety Open Message Selection, determines the fault message displayed when FB01 is triggered.

HOA Keypad Display	Fault Name
FB02	BAS Interlock Open Time Out <b>Note:</b> A fault reset is required. An EF0 is sent to the drive and bypass contactor K3 is not affected.
	BAS/Damper Interlock Open, Interlock Wait Timer Expired
Cause	Possible Solution
The digital input set to BAS Interlock is open	<ul style="list-style-type: none"> <li>• Install a NC BAS Interlock Circuit/Damper Interlock between DI-□ and IG-24 on PCB A2</li> <li>• Install a jumper between DI-2 and IG-24 on PCB A2. Use this method if a safety circuit will be added in the future or is no safety circuit will be used at all.</li> <li>• Verify that the input assigned for the BAS Interlock is active within the timeout period set in Z1-15.</li> </ul>

HOA Keypad Display	Fault Name
FB03	External Fault Bypass (EFB) <b>Note:</b> A fault reset is required. An EF0 is sent to the drive and drive output contactor K2 and Bypass contactor K3 are opened.
	External fault to bypass set
Cause	Possible Solution
An external fault (EFB) digital input became active.	Remove the cause of the external fault.
An external fault (EFB) was received from the serial communications network.	<ul style="list-style-type: none"> <li>• Remove the cause of the external fault</li> <li>• Remove the external fault input from the controller.</li> <li>• Verify that the controller program is correct.</li> </ul>

HOA Keypad Display	Fault Name
FB05	Motor Overload <b>Note:</b> A fault reset is required. An EF0 is sent to the drive and Bypass contactor K3 is opened.
	Motor Overload detected
Cause	Possible Solution
Load is too heavy	Reduce the load.
Cycle times are too short during acceleration and deceleration.	Increase the acceleration and deceleration times (C1-01 and C1-02).



HOA Keypad Display	Fault Name
A general-purpose motor is driven below the rated speed with a high load	<ul style="list-style-type: none"> <li>Reduce the load.</li> <li>Increase the speed.</li> <li>If the motor is supposed to operate at low speeds, either increase the motor capacity or use a motor specifically designed to operate in the desired speed range.</li> </ul>
The wrong motor rated current is set to E2-01	<ul style="list-style-type: none"> <li>Check the motor-rated current.</li> <li>Enter the motor rated current to parameter E2-01 as indicated on the motor nameplate.</li> </ul>
The maximum output frequency is set incorrectly	Check the E1-03 setting.
Multiple motors are running off the same bypass	Set L1-01 to 0 to disable the motor protection function and then install a thermal relay to each motor.
The electrical thermal protection characteristics and motor overload characteristics do not match.	<ul style="list-style-type: none"> <li>Check the motor characteristics.</li> <li>Correct the type of motor protection that has been selected (L1-01).</li> <li>Install an external thermal relay.</li> </ul>
The electrical thermal relay is operating at the wrong level.	<ul style="list-style-type: none"> <li>Check the current rating listed on the motor nameplate.</li> <li>Check the value set for the motor rated current (E2-01)</li> </ul>

HOA Keypad Display	Fault Name
FB06	External Motor 1 Overload
	<p><b>Note:</b> A fault reset is not required. An EF0 is sent to the drive and bypass Contactor K3 is opened.</p> <p>S10 overload input is active for motor 1</p>
<b>Cause</b>	<b>Possible Solution</b>
Load is too heavy	Reduce the load.
Cycle times are too short during acceleration and deceleration	Increase the acceleration and deceleration times (C1-01 and C1-02).
A general-purpose motor is driven below the rated speed with a high load	<ul style="list-style-type: none"> <li>Reduce the load.</li> <li>Increase the speed.</li> <li>If the motor is supposed to operate at low speeds, either increase the motor capacity or use a motor specifically designed to operate in the desired speed range.</li> </ul>

HOA Keypad Display	Fault Name
FB07	External Motor 2 Overload
	<p><b>Note:</b> A fault reset is not required. An EF0 is sent to the drive and bypass contactor K3 is opened.</p> <p>External overload input is active for motor 2</p>
<b>Cause</b>	<b>Possible Solution</b>
Load is too heavy	Reduce the load.
Cycle times are too short during acceleration and deceleration	Increase the acceleration and deceleration times (C1-01 and C1-02).
A general-purpose motor is driven below the rated speed with a high load	<ul style="list-style-type: none"> <li>Reduce the load.</li> <li>Increase the speed.</li> <li>If the motor is supposed to operate at low speeds, either increase the motor capacity or use a motor specifically designed to operate in the desired speed range.</li> </ul>

HOA Keypad Display	Fault Name
FB08	Phase Loss Brownout
	<p><b>Note:</b> A fault reset is required. An EF0 is sent to the drive and drive output contactor K2 and Bypass contactor K3 are opened.</p> <p>The contactor coil voltage was continuously detected below the configured brownout voltage level for the configured brownout time.</p>
<b>Cause</b>	<b>Possible Solution</b>
Input power is too low.	Verify input power is sufficient to power the bypass.
Settings for brownout are incorrect.	Verify Z1-27 (Brownout Voltage Level) and Z1-28 (Brownout Time) are set properly.

## 6.4 Fault Detection

HOA Keypad Display	Fault Name
FB09	Phase Loss Blackout <b>Note:</b> A fault reset is required. An EF0 is sent to the drive and drive output contactor K2 and Bypass contactor K3 are opened.
	The contactor coil voltage was detected below the configured blackout voltage level.
<b>Cause</b>	<b>Possible Solution</b>
Input power is too low or has dipped too low.	Verify input power is sufficient to power the bypass.
Settings for blackout are incorrect.	Verify Z1-29 (Blackout Voltage Level) is set properly.

HOA Keypad Display	Fault Name
FB10	No Drive Comms <b>Note:</b> A fault reset is required. An EF0 is not sent to the drive and Bypass contactor K3 is not affected.
	An unexpected loss of communication to the drive lasting longer than 15 seconds has been detected.
<b>Cause</b>	<b>Possible Solution</b>
The cable between the bypass controller and the drive is disconnected or has been damaged.	Verify the cable between the bypass controller board (A2) connector CN6 to drive terminal TB4 is connected at both ends and is not damaged.
The bypass controller circuit has become defective.	Replace the bypass control board.
The drive circuitry has become defective.	Replace the drive.

HOA Keypad Display	Fault Name
FB11	Bypass Board Hardware Error <b>Note:</b> A fault reset is not required. An EF0 is not sent to the drive. The drive output contactor K2 and and bypass contactor K3 are opened.
	The bypass control board failed.
<b>Cause</b>	<b>Possible Solution</b>
An unexpected event occurred with the bypass controller circuitry.	Replace the bypass controller board.

HOA Keypad Display	Fault Name
FB12	Option Board Comms <b>Note:</b> Fault reset will not remove the fault.
	Loss of communication to the communication option board. This fault can only occur if the bypass is programmed to be controlled by the option card (one or more of the following): Z1-07 = 3, Z1-08 = 2, Z1-38 = 2, or Z1-39 = 2.
<b>Cause</b>	<b>Possible Solution</b>
Communication between the option card and bypass board have timed out and communication has stopped	Ensure the option card is mounted properly. Replace the option card and cycle power to the bypass board.

HOA Keypad Display	Fault Name
FB13	Loss of Load <b>Note:</b> A fault reset is required. An EF0 fault is sent to the drive and drive output contactor K2 and bypass contactor K3 are opened.
	The conditions were such that it appears the motor has become disconnected from the load.
<b>Cause</b>	<b>Possible Solution</b>
The motor is disconnect from the drive	Check the continuity between the drive/bypass and the motor.
The load has been disconnected from the motor	Check the belt/coupling between the motor and the load
The Loss of Load settings are not proper.	Review and adjust the Loss of Load parameters Z1-31 to Z1-36.

HOA Keypad Display	Fault Name
FB14	Serial Communications Fault <b>Note:</b> A fault reset is required. Behavior of the drive and the contactors during an FB14 fault is determined by parameter Z3-05.
	Serial communications timeout
<b>Cause</b>	<b>Possible Solution</b>

HOA Keypad Display	Fault Name
Faulty communication wiring or an existing short circuit.	<ul style="list-style-type: none"> <li>• Check for faulty serial communication wiring</li> <li>• Correct the wiring</li> <li>• Check for disconnected cables and short circuits and repair as needed.</li> </ul>
Communication data error occurred due to noise.	<ul style="list-style-type: none"> <li>• Check the various options available to minimize the effects of noise</li> <li>• Counteract noise in the control circuit, main circuit, and ground wiring</li> <li>• Use only recommended cables or other shielded line. Ground the shield on the controller side</li> <li>• Ensure that other equipment such as switches or relays do not cause noise. Use surge suppressors if required</li> <li>• Separate all communication wiring from power lines. When the lines must cross, make the lines cross at a right angle to minimize noise coupling.</li> </ul>
Communication Error timeout time not set properly.	Verify the setting of the serial communications fault time (Z3-06) is set properly.
Controller is not sending data soon enough to stop the timeout.	Verify the scan rate in the controller that is communicating with the bypass controller is proper. Adjust as necessary.

HOA Keypad Display	Fault Name
FB15 </>	Input Phase Loss
<b>Cause</b>	<b>Possible Solutions</b>
Bypass Mode current unbalance condition exceeded the unbalance level limit set by Z1-50 for the amount of time specified in Z1-51.	<ul style="list-style-type: none"> <li>• Check input wiring including fuses, breakers, and connections upstream from the bypass.</li> <li>• Check the motor wiring and connections.</li> </ul>

<1> Available in bypass controller software versions VST800298 and later.

HOA Keypad Display	Fault Name
FB16 </>	Input Phase Rotation
<b>Cause</b>	<b>Possible Solution</b>
Incorrect phase rotation while Z1-52 is set to 2 in Bypass Mode.	Check the sequence (phase rotation) of the input wiring to the bypass package.

<1> Available in bypass controller software versions VST800298 and later.

HOA Keypad Display	Fault Name
FB17 </>	Load Lost
<b>Cause</b>	<b>Possible Solution</b>
Drive or bypass output current is less than 5% of E2-01, Motor Rated Current, for longer than 10 seconds.	Close all external output disconnects. <ul style="list-style-type: none"> <li>• Verify that the frequency reference or PID <math>\neq</math> 0.</li> <li>• Set d2-02 &gt; 0.0%.</li> </ul>

<1> Available in bypass controller software versions VST800400 and later.

HOA Keypad Display	Fault Name
FB18 </>	K3 Welded
<b>Cause</b>	<b>Possible Solution</b>
The bypass detected a welded K3 contactor condition.	Inspect K3 contactor.

<1> Available in bypass controller software versions VST800400 and later.

HOA Keypad Display	Fault Name
FB19 </>	Duplicate Input
<b>Cause</b>	<b>Possible Solution</b>
The bypass detected a duplicate digital input selection.	Check for duplicate settings in parameters Z2-01 through Z2-08. <b>Note:</b> Multiple settings of "0" are allowed and will not trigger this fault.

<1> Available in bypass controller software versions VST800400 and later.

HOA Keypad Display	Fault Name
FB20 </>	Fire Stat
<b>Cause</b>	<b>Possible Solution</b>

## 6.4 Fault Detection

HOA Keypad Display	Fault Name
The bypass detected a Fire Stat fault condition.	Inspect the digital input programmed for Fire Stat (Z2-0□ = 38). Check the connected device for continuity. Check Bypass Digital Input Invert Settings in Z2-09 to Z2-16.

<1> Available in bypass controller software versions VST800400 and later.

HOA Keypad Display	Fault Name
FB21 <1>	Freeze Stat
<b>Cause</b>	<b>Possible Solution</b>
The bypass detected a Freeze Stat fault condition.	Inspect the digital input programmed for Freeze Stat (Z2-0□ = 39). Check the connected device for continuity. Check Bypass Digital Input Invert Settings in Z2-09 to Z2-16.

<1> Available in bypass controller software versions VST800400 and later.

HOA Keypad Display	Fault Name
FB22 <1>	Smoke Alarm
<b>Cause</b>	<b>Possible Solution</b>
The bypass detected a Smoke Alarm fault condition.	Inspect the digital input programmed for Smoke Alarm (Z2-0□ = 40). Check the connected device for continuity. Check Bypass Digital Input Invert Settings in Z2-09 to Z2-16.

<1> Available in bypass controller software versions VST800400 and later.

HOA Keypad Display	Fault Name
FB23 <1>	Over Pressure
<b>Cause</b>	<b>Possible Solution</b>
The bypass detected an Over Pressure fault condition.	Inspect the digital input programmed for Over Pressure (Z2-0□ = 41). Check the connected device for continuity. Check Bypass Digital Input Invert Settings in Z2-09 to Z2-16.

<1> Available in bypass controller software versions VST800400 and later.

HOA Keypad Display	Fault Name
FB24 <1>	Low Suction
<b>Cause</b>	<b>Possible Solution</b>
The bypass detected a Low Suction fault condition.	Inspect the digital input programmed for Low Suction (Z2-0□ = 42). Check the connected device for continuity. Check Bypass Digital Input Invert Settings in Z2-09 to Z2-16.

<1> Available in bypass controller software versions VST800400 and later.

HOA Keypad Display	Fault Name
FB25 <1>	Vibration Switch
<b>Cause</b>	<b>Possible Solution</b>
The bypass detected a Vibration Switch fault condition.	Inspect the digital input programmed for Vibration Switch (Z2-0□ = 43). Check the connected device for continuity. Check Bypass Digital Input Invert Settings in Z2-09 to Z2-16.

<1> Available in bypass controller software versions VST800400 and later.

HOA Keypad Display	Fault Name
FB26 <1>	Option On Drive
<b>Cause</b>	<b>Possible Solution</b>
A communications option PCB is mounted directly on drive terminal CN5.	Remove the option from the drive and install it on terminal CN5 on the bypass controller.

<1> Available in bypass controller software versions VST800400 and later.

HOA Keypad Display	Fault Name
Fn1	External Fan Fault
	External fan failure
<b>Cause</b>	<b>Possible Solution</b>

HOA Keypad Display	Fault Name
External cooling fan has malfunctioned	<ul style="list-style-type: none"> <li>• Cycle power to the drive.</li> <li>• Check for fan operation.</li> <li>• Verify the cumulative operation time of the fan with monitor U4-03, and verify the cumulative operation time of the fan maintenance timer with U4-04.</li> <li>• If the cooling fan has exceeded its expected performance life or is damaged in any other way, follow the replacement instructions in the <i>Periodic Inspection &amp; Maintenance</i> chapter.</li> </ul>

HOA Keypad Display	Fault Name
FbH	Excessive PI Feedback
	PI feedback input is greater than the level set to b5-36 for longer than the time set to b5-37. Set b5-12 to 2 or 5 to enable fault detection.
<b>Cause</b>	<b>Possible Solution</b>
Parameters are set inappropriately	Check b5-36 and b5-37 settings.
Incorrect PI feedback wiring	Correct the wiring.
There is a problem with the feedback sensor	<ul style="list-style-type: none"> <li>• Check the sensor on the control side.</li> <li>• Replace the sensor if damaged.</li> </ul>

HOA Keypad Display	Fault Name
FbL	PI Feedback Loss
	This fault occurs when PI feedback loss detection is programmed to trigger a fault (b5-12 = 2) and the PI feedback level is below the detection level set to b5-13 for longer than the time set to b5-14.
<b>Cause</b>	<b>Possible Solution</b>
Parameters are set inappropriately	Check b5-13 and b5-14 settings.
Incorrect PI feedback wiring	Correct the wiring.
There is a problem with the feedback sensor	<ul style="list-style-type: none"> <li>• Check the sensor on the control side.</li> <li>• Replace the sensor if damaged.</li> </ul>

HOA Keypad Display	Fault Name
GF	Ground Fault
	<ul style="list-style-type: none"> <li>• A current short to ground exceeded 50% of rated current on the output side of the drive.</li> <li>• Setting L8-09 to 1 enables ground fault detection in models Z1B1D074 to D273 and B052 to B302.</li> </ul>
<b>Cause</b>	<b>Possible Solution</b>
Motor insulation is damaged	<ul style="list-style-type: none"> <li>• Check the insulation resistance of the motor.</li> <li>• Replace the motor.</li> </ul>
A damaged motor cable is creating a short circuit	<ul style="list-style-type: none"> <li>• Check the motor cable.</li> <li>• Remove the short circuit and reapply power to the drive</li> <li>• Check the resistance between the cable and the ground terminal ⊕.</li> <li>• Replace the cable.</li> </ul>
Excessive leakage current at the drive output	<ul style="list-style-type: none"> <li>• Reduce the carrier frequency.</li> <li>• Reduce the amount of stray capacitance.</li> </ul>
The drive started to run during a current offset fault or while coasting to a stop	Set b3-01 to 1 to enable Speed Search at Start.
Hardware problem	If the problem continues, replace the control board or the entire drive. Contact Yaskawa or a Yaskawa representative for instructions on replacing the control board.

HOA Keypad Display	Fault Name
LF	Output Phase Loss
	<ul style="list-style-type: none"> <li>• Phase loss on the output side of the drive.</li> <li>• Setting L8-07 to 1 or 2 enables Phase Loss Detection.</li> </ul>
<b>Cause</b>	<b>Possible Solution</b>
The output cable is disconnected	<ul style="list-style-type: none"> <li>• Check for wiring errors and properly connect the output cable.</li> <li>• Correct the wiring.</li> </ul>
The motor winding is damaged	<ul style="list-style-type: none"> <li>• Check the resistance between motor lines.</li> <li>• Replace the motor if the winding is damaged.</li> </ul>
The output terminal is loose	<ul style="list-style-type: none"> <li>• Apply the tightening torque specified in this manual to fasten the terminals. <i>Refer to Wire Gauge and Tightening Torque Specifications on page 62</i> for details.</li> </ul>

## 6.4 Fault Detection

HOA Keypad Display	Fault Name
The rated current of the motor being used is less than 5% of the drive rated current	Check the drive and motor capacities.
An output transistor is damaged	If the problem continues, replace the control board or the entire drive. Contact Yaskawa or a Yaskawa representative for instructions on replacing the control board.
A single-phase motor is being used	The drive cannot operate a single phase motor.

HOA Keypad Display	Fault Name
LF2	Output Current Imbalance
	One or more of the phases in the output current are lost.
Cause	Possible Solution
Phase loss has occurred on the output side of the drive	<ul style="list-style-type: none"> <li>• Check for faulty wiring or poor connections on the output side of the drive.</li> <li>• Correct the wiring.</li> </ul>
Terminal wires are loose on the output side of the drive	Apply the tightening torque specified in this manual to fasten the terminals. <i>Refer to Wire Gauge and Tightening Torque Specifications on page 62</i> for details.
The output circuit is damaged	If the problem continues, replace the control board or the entire drive. Contact Yaskawa or a Yaskawa representative for instructions on replacing the control board.
Motor impedance or motor phases are uneven	<ul style="list-style-type: none"> <li>• Measure the line-to-line resistance for each motor phase. Ensure all values match.</li> <li>• Replace the motor.</li> </ul>

HOA Keypad Display	Fault Name
nSE	Node Setup Error
	A terminal assigned to the node setup function closed during run.
Cause	Possible Solution
The node setup terminal closed during run	Stop the drive when using the node setup function.
A Run command was issued while the node setup function was active	

HOA Keypad Display	Fault Name
oC	Overcurrent
	Drive sensors detected an output current greater than the specified overcurrent level.
Cause	Possible Solution
The motor has been damaged due to overheating or the motor insulation is damaged	<ul style="list-style-type: none"> <li>• Check the insulation resistance.</li> <li>• Replace the motor.</li> </ul>
One of the motor cables has shorted out or there is a grounding problem	<ul style="list-style-type: none"> <li>• Check the motor cables.</li> <li>• Remove the short circuit and reapply power to the drive.</li> <li>• Check the resistance between the motor cables and the ground terminal ⊕.</li> <li>• Replace damaged cables.</li> </ul>
The load is too heavy	<ul style="list-style-type: none"> <li>• Measure the current flowing into the motor.</li> <li>• Replace the drive with a larger capacity drive if the current value exceeds the rated current.</li> <li>• Determine if there is sudden fluctuation in the current level.</li> <li>• Reduce the load to avoid sudden changes in the current level or switch to a larger drive.</li> </ul>
The acceleration or deceleration times are too short	Calculate the torque needed during acceleration relative to the load inertia and the specified acceleration time. If it is not possible to set the proper amount of torque, make the following changes: <ul style="list-style-type: none"> <li>• Increase the acceleration time (C1-01)</li> <li>• Increase the S-curve characteristics (C2-01 and C2-02)</li> <li>• Increase the capacity of the drive.</li> </ul>
The drive is attempting to operate a specialized motor or a motor larger than the maximum size allowed	<ul style="list-style-type: none"> <li>• Check the motor capacity.</li> <li>• Ensure that the rated capacity of the drive is greater than or equal to the capacity rating found on the motor nameplate.</li> </ul>
Magnetic contactor (MC) on the output side of the drive has turned on or off	Set up the operation sequence so the MC does not trip while the drive is outputting current.
V/f setting is not operating as expected	<ul style="list-style-type: none"> <li>• Check the ratios between the voltage and frequency.</li> <li>• Lower the voltage if it is too high relative to the frequency.</li> </ul>
Excessive torque compensation	<ul style="list-style-type: none"> <li>• Check the amount of torque compensation.</li> <li>• Reduce the torque compensation gain (C4-01) until there is no speed loss and less current.</li> </ul>

HOA Keypad Display	Fault Name
Drive fails to operate properly due to noise interference	<ul style="list-style-type: none"> <li>Review the possible solutions provided for handling noise interference.</li> <li>Review the section on handling noise interference on page 263 and check the control circuit lines, main circuit lines, and ground wiring.</li> </ul>
Overexcitation gain is set too high	<ul style="list-style-type: none"> <li>Check if the fault occurs simultaneously with overexcitation function operation.</li> <li>Consider motor flux saturation and reduce the value of n3-13 (Overexcitation Deceleration Gain).</li> </ul>
Run command was applied while motor was coasting	Set b3-01 to 1 to enable Speed Search at Start.
The rated output current of the drive is too small	Use a larger drive.

HOA Keypad Display	Fault Name
oFA00	Option Card Connection Error at Option Port CN5
	Option compatibility error
<b>Cause</b>	<b>Possible Solution</b>
The option card installed into port CN5 is incompatible with the drive	Check if the drive supports the option card to be installed. Contact Yaskawa for assistance.

HOA Keypad Display	Fault Name
oH	Heatsink Overheat
	The heatsink temperature exceeded the overheat pre-alarm level set to L8-02. The default value for L8-02 is determined by drive capacity (o2-04).
<b>Cause</b>	<b>Possible Solution</b>
Surrounding temperature is too high	<ul style="list-style-type: none"> <li>Check the temperature surrounding the drive. Verify temperature is within drive specifications.</li> <li>Improve the air circulation within the enclosure panel.</li> <li>Install a fan or air conditioner to cool the surrounding area.</li> <li>Remove anything near the drive that might be producing excessive heat.</li> </ul>
Load is too heavy	<ul style="list-style-type: none"> <li>Measure the output current.</li> <li>Decrease the load.</li> <li>Lower the carrier frequency (C6-02).</li> </ul>
External cooling fan is stopped	<ul style="list-style-type: none"> <li>Replace the cooling fan. <i>Refer to Cooling Fan Replacement: 2A0011 to 2A0059, 4A0005 to 4A0040, and 4A0052 □□B on page 293.</i></li> <li>After replacing the cooling fan, set parameter o4-03 to 0 to reset the cooling fan maintenance.</li> </ul>

HOA Keypad Display	Fault Name
oH1	Overheat 1 (Heatsink Overheat)
	The heatsink temperature exceeded the drive overheat level. Overheat level is determined by drive capacity (o2-04).
<b>Cause</b>	<b>Possible Solution</b>
Surrounding temperature is too high	<ul style="list-style-type: none"> <li>Check the temperature surrounding the drive.</li> <li>Improve the air circulation within the enclosure panel.</li> <li>Install a fan or air conditioner to cool the surrounding area.</li> <li>Remove anything near the drive that might be producing excessive heat.</li> </ul>
Load is too heavy	<ul style="list-style-type: none"> <li>Measure the output current.</li> <li>Lower the carrier frequency (C6-02).</li> <li>Reduce the load.</li> </ul>

HOA Keypad Display	Fault Name
oH3	Motor Overheat Alarm (PTC Input)
	<ul style="list-style-type: none"> <li>The motor overheat signal to analog input terminals A1 or A2 exceeded the alarm detection level.</li> <li>Detection requires setting multi-function analog inputs H3-02 or H3-10 to E.</li> </ul>
<b>Cause</b>	<b>Possible Solution</b>

## 6.4 Fault Detection

HOA Keypad Display	Fault Name
Motor has overheated	<ul style="list-style-type: none"> <li>• Check the size of the load, the accel/decel times, and the cycle times.</li> <li>• Decrease the load.</li> <li>• Increase the acceleration and deceleration times (C1-01 and C1-02).</li> </ul>
	Adjust the preset V/f pattern. Try setting E1-03 to 6.
	<ul style="list-style-type: none"> <li>• Check the motor rated current.</li> <li>• Enter the motor rated current to parameter E2-01 as indicated on the motor nameplate.</li> <li>• Ensure the motor cooling system is operating normally.</li> <li>• Repair or replace the motor cooling system.</li> </ul>

HOA Keypad Display	Fault Name
oH4	Motor Overheat Fault (PTC Input)
	<ul style="list-style-type: none"> <li>• The motor overheat signal to analog input terminal A1 or A2 exceeded the fault detection level.</li> <li>• Detection requires setting multi-function analog inputs H3-02 or H3-10 to E.</li> </ul>
<b>Cause</b>	<b>Possible Solution</b>
Motor has overheated	<ul style="list-style-type: none"> <li>• Check the size of the load, the accel/decel times, and the cycle times.</li> <li>• Decrease the load.</li> <li>• Increase the acceleration and deceleration times (C1-01 and C1-02).</li> </ul>
	Adjust the preset V/f pattern. Set E1-03 to 6.
	<ul style="list-style-type: none"> <li>• Check the motor rated current.</li> <li>• Enter the motor rated current to parameter E2-01 as indicated on the motor nameplate.</li> <li>• Ensure the motor cooling system is operating normally.</li> <li>• Repair or replace the motor cooling system.</li> </ul>

HOA Keypad Display	Fault Name
oL1	Motor Overload
	The electronic motor overload protection tripped
<b>Cause</b>	<b>Possible Solution</b>
Load is too heavy	Reduce the load.
Cycle times are too short during acceleration and deceleration	Increase the acceleration and deceleration times (C1-01 and C1-02).
A general-purpose motor is driven below the rated speed with a high load	<ul style="list-style-type: none"> <li>• Reduce the load.</li> <li>• Increase the speed.</li> <li>• If the motor is supposed to operate at low speeds, either increase the motor capacity or use a motor specifically designed to operate in the desired speed range.</li> </ul>
The output voltage is too high	<ul style="list-style-type: none"> <li>• Adjust the V/f pattern. Set E1-03 to 6.</li> <li>• Do not set E1-08 and E1-10 too low. This reduces load tolerance at low speeds.</li> </ul>
The wrong motor rated current is set to E2-01	<ul style="list-style-type: none"> <li>• Check the motor-rated current.</li> <li>• Enter the motor rated current to parameter E2-01 as indicated on the motor nameplate.</li> </ul>
The maximum output frequency is set incorrectly	<ul style="list-style-type: none"> <li>• Check the rated frequency indicated on the motor nameplate.</li> <li>• Set E1-03 to a V/f pattern matching the application.</li> </ul>
Multiple motors are running off the same drive	Set L1-01 to 0 to disable the motor protection function and then install a thermal relay to each motor.
The electrical thermal protection characteristics and motor overload characteristics do not match	<ul style="list-style-type: none"> <li>• Check the motor characteristics.</li> <li>• Correct the type of motor protection that has been selected (L1-01).</li> <li>• Install an external thermal relay.</li> </ul>
The electrical thermal relay is operating at the wrong level	<ul style="list-style-type: none"> <li>• Check the current rating listed on the motor nameplate.</li> <li>• Check the value set for the motor rated current (E2-01).</li> </ul>
Motor overheated by overexcitation operation	<ul style="list-style-type: none"> <li>• Overexcitation increases the motor loss and the motor temperature. Excessive duration of overexcitation may cause motor damage. Prevent excessive overexcitation operation or apply proper cooling to the motor.</li> <li>• Reduce the excitation deceleration gain (n3-13).</li> <li>• Set L3-04 (Stall Prevention during Deceleration) to a value other than 4.</li> </ul>
Parameters related to Speed Search are set incorrectly	<ul style="list-style-type: none"> <li>• Check values set to Speed Search related parameters.</li> <li>• Adjust the Speed Search current and Speed Search deceleration times (b3-02 and b3-03 respectively).</li> </ul>
Output current fluctuation due to input phase loss	Check the power supply for phase loss.



HOA Keypad Display	Fault Name
oL2	Drive Overload
	The thermal sensor of the drive triggered overload protection.
<b>Cause</b>	<b>Possible Solution</b>
Load is too heavy	Reduce the load.
Acceleration or deceleration time is too short	Increase the settings for the acceleration and deceleration times (C1-01 and C1-02).
The output voltage is too high	<ul style="list-style-type: none"> <li>Set E1-03 to a V/f pattern matching the application.</li> <li>Do not lower E1-08 and E1-10 excessively. This reduces load tolerance at low speeds.</li> </ul>
Drive capacity is too small	Replace the drive with a larger model.
Overload occurred when operating at low speeds	<ul style="list-style-type: none"> <li>Reduce the load when operating at low speeds.</li> <li>Replace the drive with a model that is one frame size larger.</li> <li>Lower the carrier frequency (C6-02).</li> </ul>
Excessive torque compensation	Reduce the torque compensation gain in parameter C4-01 until there is no speed loss but less current.
Parameters related to Speed Search are set incorrectly	<ul style="list-style-type: none"> <li>Check the settings for all Speed Search related parameters.</li> <li>Adjust the current used during Speed Search (b3-03) and the Speed Search deceleration time (b3-02).</li> <li>After Auto-Tuning, set b3-24 to 1 to enable Speed Estimation Speed Search.</li> </ul>
Output current fluctuation due to input phase loss	Check the power supply for phase loss.

HOA Keypad Display	Fault Name
oL3	Overtorque Detection 1
	The current has exceeded the value set for torque detection (L6-02) for longer than the allowable time (L6-03).
<b>Cause</b>	<b>Possible Solution</b>
Parameter settings are not appropriate for the load	Check L6-02 and L6-03 settings.
Fault on the machine side (e.g., machine is locked up)	Check the status of the load. Remove the cause of the fault.

HOA Keypad Display	Fault Name
oL7	High Slip Braking oL
	The output frequency stayed constant for longer than the time set to n3-04 during High Slip Braking.
<b>Cause</b>	<b>Possible Solution</b>
Excessive load inertia	Reduce deceleration time in parameter C1-02 for applications that do not use High Slip Braking.
Motor is driven by the load	
Something on the load side is restricting deceleration	
The overload time during High Slip Braking is too short	<ul style="list-style-type: none"> <li>Increase parameter n3-04 (High-slip Braking Overload Time).</li> <li>Install a thermal relay and increase the setting of n3-04 to maximum value.</li> </ul>

HOA Keypad Display	Fault Name
oPr	HOA Keypad Connection Fault
	The HOA keypad has been disconnected from the drive. <b>Note:</b> An oPr fault will occur when The Run command is assigned to the keypad (Z1-07 = 0 and OFF mode has been selected).
<b>Cause</b>	<b>Possible Solution</b>
External operator is not properly connected to the drive	<ul style="list-style-type: none"> <li>Check the connection between the operator and the drive.</li> <li>Replace the cable if damaged.</li> <li>Turn off the drive input power and disconnect the operator. Reconnect the operator and reapply drive input power.</li> </ul>

HOA Keypad Display	Fault Name
ov	Overvoltage
	Voltage in the DC bus has exceeded the overvoltage detection level. <ul style="list-style-type: none"> <li>For 208 V: approximately 410 V</li> <li>For 480 V: approximately 820 V (740 V when E1-01 is less than 400)</li> </ul>
<b>Cause</b>	<b>Possible Solution</b>

## 6.4 Fault Detection

HOA Keypad Display	Fault Name
Deceleration time is too short and regenerative energy is flowing from the motor into the drive	<ul style="list-style-type: none"> <li>• Increase the deceleration time (C1-02).</li> <li>• Set L3-04 to 1 to enable stall prevention during deceleration. Stall Prevention is enabled as the default setting.</li> </ul>
Fast acceleration time causes the motor to overshoot the speed reference	<ul style="list-style-type: none"> <li>• Check if sudden drive acceleration triggers an overvoltage alarm.</li> <li>• Increase the acceleration time.</li> <li>• Use longer S-curve acceleration and deceleration times.</li> <li>• Enable the Overvoltage Suppression function (L3-11 = 1).</li> <li>• Lengthen the S-curve at acceleration end.</li> </ul>
Ground fault in the output circuit causes the DC bus capacitor to overcharge	<ul style="list-style-type: none"> <li>• Check the motor wiring for ground faults.</li> <li>• Correct grounding shorts and reapply power.</li> </ul>
Improper parameters related to Speed Search (including Speed Search after a momentary power loss and after a fault restart)	<ul style="list-style-type: none"> <li>• Check the settings for Speed Search-related parameters.</li> <li>• Enable Speed Search restart function (b3-19 greater than or equal to 1 to 10).</li> <li>• Adjust the current level during Speed Search and the deceleration time (b3-02 and b3-03 respectively).</li> <li>• Perform Stationary Auto-Tuning for line-to-line resistance and then set b3-14 to 1 to enable Speed Estimation Speed Search.</li> </ul>
Drive input power voltage is too high	<ul style="list-style-type: none"> <li>• Check the voltage.</li> <li>• Lower drive input power voltage within the limits listed in the specifications.</li> </ul>
Drive fails to operate properly due to noise interference	<ul style="list-style-type: none"> <li>• Review the list of possible solutions provided for controlling noise.</li> <li>• Review the section on handling noise interference on page 263 and check the control circuit lines, main circuit lines, and ground wiring.</li> </ul>
Load inertia is set incorrectly	<ul style="list-style-type: none"> <li>• Check the load inertia settings when using KEB, overvoltage suppression, or Stall Prevention during deceleration.</li> <li>• Adjust the load inertia ratio in L3-25 to better match the load.</li> </ul>
Motor hunting occurs	<ul style="list-style-type: none"> <li>• Adjust the parameters that control hunting.</li> <li>• Set the gain for Hunting Prevention (n1-02).</li> </ul>

HOA Keypad Display	Fault Name
ov2	Overvoltage 2
	Bus voltage is boosted because the motor cable is too long.
<b>Cause</b>	<b>Possible Solution</b>
The wiring is too long	<ul style="list-style-type: none"> <li>• Shorten the shielded motor cable</li> <li>• Lower the carrier frequency</li> <li>• Switch on the internal EMC filter if the power supply has a neutral ground</li> </ul>

HOA Keypad Display	Fault Name
PF	Input Phase Loss
	Drive input power has an open phase or has a large imbalance of voltage between phases. Detected when L8-05 is set 1 (enabled).
<b>Cause</b>	<b>Possible Solution</b>
There is phase loss in the drive input power	<ul style="list-style-type: none"> <li>• Check for wiring errors in the main circuit drive input power.</li> <li>• Correct the wiring.</li> </ul>
There is loose wiring in the drive input power terminals	<ul style="list-style-type: none"> <li>• Ensure the terminals are tightened properly.</li> <li>• Apply the tightening torque as specified in this manual. <i>Refer to Wire Gauge and Tightening Torque Specifications on page 62</i> for details.</li> </ul>
There is excessive fluctuation in the drive input power voltage	<ul style="list-style-type: none"> <li>• Check the voltage from the drive input power.</li> <li>• Review the possible solutions for stabilizing the drive input power.</li> </ul>
There is poor balance between voltage phases	Stabilize drive input power or disable phase loss detection.
The main circuit capacitors are worn	<ul style="list-style-type: none"> <li>• Check the maintenance time for the capacitors (U4-05).</li> <li>• Replace the capacitor if U4-05 is greater than 90%. For instructions on replacing the capacitor, contact Yaskawa or a Yaskawa representative.</li> </ul> <p>Check for problems with the drive input power. If drive input power appears normal but the alarm continues to occur, replace either the control board or the entire drive. For instructions on replacing the control board, contact Yaskawa or a Yaskawa representative.</p>

HOA Keypad Display	Fault Name
SEr	Too Many Speed Search Restarts
	The number of Speed Search restarts exceeded the value set to b3-19.
<b>Cause</b>	<b>Possible Solution</b>
Parameters related to Speed Search are set to the wrong values	<ul style="list-style-type: none"> <li>Reduce the detection compensation gain during Speed Search (b3-10).</li> <li>Increase the current level when attempting Speed Search (b3-17).</li> <li>Increase the detection time during Speed Search (b3-18).</li> </ul>
The motor is coasting in the opposite direction of the Run command	Set b3-14 to 1 to enable Bi-Directional Speed Search.

HOA Keypad Display	Fault Name
STo	Motor Pull Out or Step Out Detection
	Motor pull out or step out has occurred. Motor has exceeded its pull-out torque.
<b>Cause</b>	<b>Possible Solution</b>
Load is too heavy	<ul style="list-style-type: none"> <li>Increase the pull-in current during accel/decel (n8-51).</li> <li>Reduce the load.</li> <li>Increase the motor or drive capacity.</li> </ul>
Acceleration and deceleration times are too short	<ul style="list-style-type: none"> <li>Increase the acceleration and deceleration times (C1-01 and C1-02).</li> <li>Increase the S-curve acceleration and deceleration times (C2-01).</li> </ul>

HOA Keypad Display	Fault Name
TdE	Time Data Error
<b>Cause</b>	<b>Possible Solution</b>
An error has occurred in the Real-Clock Time function of the HOA keypad	Replace the HOA keypad. For instructions on replacing the HOA keypad, contact Yaskawa or your nearest sales representative.
A communication error has occurred with the Real-Clock Time function of the HOA keypad	

HOA Keypad Display	Fault Name
TIM	Time Not Set
<b>Cause</b>	<b>Possible Solution</b>
The time for the HOA keypad has not been set	Set the time for the HOA keypad.
The HOA keypad battery is low or the battery has been replaced	Replace the HOA keypad battery and set the current time.
An error has occurred in the Real-Time Clock function of the HOA keypad	Replace the HOA keypad. For instructions on replacing the HOA keypad, contact Yaskawa or your nearest sales representative.

HOA Keypad Display	Fault Name
UL3	Undertorque Detection 1
	The current has fallen below the minimum value set for torque detection (L6-02) for longer than the allowable time (L6-03).
<b>Cause</b>	<b>Possible Solution</b>
Parameter settings are not appropriate for the load	Check the settings of parameters L6-02 and L6-03.
There is a fault on the machine side	Check the load for any problems.

HOA Keypad Display	Fault Name
UL6	Motor Underload
	The weight of the load has fallen below the underload curve defined in L6-14.
<b>Cause</b>	<b>Possible Solution</b>
The output current has fallen below the motor underload curve defined in L6-14 for longer than the time set to L6-03	Adjust the value set to L6-14 so that output current remains above the motor underload curve during normal operation.

## 6.4 Fault Detection

HOA Keypad Display	Fault Name
Uv1	DC Bus Undervoltage
	Voltage in the DC bus fell below the undervoltage detection level (L2-05). <ul style="list-style-type: none"> <li>For 208 V: approximately 190 V</li> <li>For 480 V: approximately 440 V</li> </ul> The fault is output only if L2-01 is set to 0 or 1 and the DC bus voltage has fallen below the level set to L2-05 for longer than the time set to L2-02 <1> .
<b>Cause</b>	<b>Possible Solution</b>
Input power phase loss	<ul style="list-style-type: none"> <li>The main circuit drive input power is wired incorrectly.</li> <li>Correct the wiring.</li> </ul>
One of the drive input power wiring terminals is loose	<ul style="list-style-type: none"> <li>Ensure there are no loose terminals.</li> <li>Apply the tightening torque specified in this manual to fasten the terminals. <i>Refer to Wire Gauge and Tightening Torque Specifications on page 62</i> for details.</li> </ul>
There is a problem with the voltage from the drive input power	<ul style="list-style-type: none"> <li>Check the voltage.</li> <li>Correct the voltage to be within the range listed in drive input power specifications.</li> <li>If there is no problem with the power supply to the main circuit, check for problems with the main circuit magnetic contactor.</li> </ul>
The power has been interrupted	Correct the drive input power.
The main circuit capacitors are worn	<ul style="list-style-type: none"> <li>Check the maintenance time for the capacitors (U4-05).</li> <li>Replace either the control board or the entire drive if U4-05 exceeds 90%. For instructions on replacing the control board, contact Yaskawa or a Yaskawa representative.</li> </ul>
The relay or contactor on the soft-charge bypass circuit is damaged	<ul style="list-style-type: none"> <li>Cycle power to the drive and see if the fault reoccurs.</li> <li>If the problem continues, replace either the control board or the entire drive. For instructions on replacing the control board, contact Yaskawa or a Yaskawa representative.</li> <li>Check monitor U4-06 for the performance life of the soft-charge bypass.</li> <li>Replace either the control board or the entire drive if U4-06 exceeds 90%. For instructions on replacing the control board, contact Yaskawa or a Yaskawa representative.</li> </ul>

<1> Details on this function can be found in the standard Z1000 Programming Manual (SIEPC71061645) at [www.yaskawa.com](http://www.yaskawa.com).

HOA Keypad Display	Fault Name
Uv2	Control Power Supply Voltage Fault
	Voltage is too low for the control drive input power.
<b>Cause</b>	<b>Possible Solution</b>
Internal circuitry is damaged	<ul style="list-style-type: none"> <li>Cycle power to the drive. Check if the fault reoccurs.</li> <li>If the problem continues, replace either the control board or the entire drive. For instructions on replacing the control board, contact Yaskawa or a Yaskawa representative.</li> </ul>

HOA Keypad Display	Fault Name
Uv3	Undervoltage 3 (Soft-Charge Circuit Fault)
	The soft-charge bypass circuit failed.
<b>Cause</b>	<b>Possible Solution</b>
The relay or contactor on the soft-charge bypass circuit is damaged	<ul style="list-style-type: none"> <li>Cycle power to the drive and see if the fault reoccurs.</li> <li>If the problem continues, replace either the control board or the entire drive. For instructions on replacing the control board, contact Yaskawa or a Yaskawa representative.</li> <li>Check monitor U4-06 for the performance life of the soft-charge bypass.</li> <li>Replace either the control board or the entire drive if U4-06 exceeds 90%. For instructions on replacing the control board, contact Yaskawa or a Yaskawa representative.</li> </ul>

HOA Keypad Display	Fault Name
voF	Output Voltage Detection Fault
	Problem detected with the voltage on the output side of the drive.
<b>Cause</b>	<b>Possible Solution</b>
Hardware is damaged	Replace the control board or the entire drive. For instructions on replacing the control board, contact Yaskawa or a Yaskawa representative.

## 6.5 Alarm Detection

### ◆ Alarm Codes, Causes, and Possible Solutions

Alarms are drive protection functions that do not necessarily cause the drive to stop. Once the cause of an alarm is removed, the drive will return to the same status it was before the alarm occurred.

When an alarm has been triggered, the ALM light on the HOA keypad display blinks and the alarm code display flashes. If a multi-function output is set for an alarm (H2-□□ = 10), that output terminal will be triggered<sup><1></sup>.

**Note:** If a multi-function output is set to close when an alarm occurs (H2-□□ = 10), it will also close when maintenance periods are reached, triggering alarms LT-1 through LT-4 (triggered only if H2-□□ = 2F<sup><1></sup>).

<1> Details on this function can be found in the standard Z1000 Programming Manual (SIEPC71061645) at [www.yaskawa.com](http://www.yaskawa.com).

**Table 6.9 Detailed Alarm Codes, Causes, and Possible Solutions**

HOA Keypad Display	Fault Name
AL02	BAS Interlock Open
<b>Cause</b>	<b>Possible Solution</b>
The digital input set to Bas interlock is open	Check to see if the damper is functioning properly. The damper may be in the process of opening and the end switch may not have closed.
HOA Keypad Display	Fault Name
AL03	Smoke Purge in Bypass <b>Note:</b> Also referred to as “Fireman's Override” (Bypass).
<b>Cause</b>	<b>Possible Solution</b>
Smoke Purge Bypass input is activated	This is typically an intentional emergency run state. Check the Z2-□□ digital input settings to determine which is set to 25, then check to the physical digital input terminal DI-□□ to determine why it is closed.
HOA Keypad Display	Fault Name
AL04	Smoke Purge in Drive <b>Note:</b> Also referred to as “Fireman's Override” (Drive).
<b>Cause</b>	<b>Possible Solution</b>
Smoke Purge Drive input is activated.	This is typically an intentional emergency run state. Check the Z2-□□ digital input settings to determine which is set to 25, then check to the physical digital input terminal DI-□□ to determine why it is closed.
HOA Keypad Display	Fault Name
AL09	Run Active during Restart Delay
<b>Cause</b>	<b>Possible Solution</b>
Drive run command is asserted during the restart delay.	This is not a fault condition, just informative to show why the drive is not running. If the run command to the drive is removed, the AL09 alarm will not be shown.
HOA Keypad Display	Fault Name
AL13	Loss of Load
<b>Cause</b>	<b>Possible Solution</b>
The conditions were such that it appears that the motor has been disconnected from the load.	Replace the belt or coupling between the motor and the load. In the event of a false detection, review parameters Z1-27 to Z1-32 and set them to more appropriate values.
HOA Keypad Display	Fault Name
AL14	Serial Comm Fault
<b>Cause</b>	<b>Possible Solution</b>
Faulty communication wiring or an existing short circuit.	<ul style="list-style-type: none"> <li>• Check for faulty serial communication wiring</li> <li>• Correct the wiring</li> <li>• Check for disconnected cables and short circuits and repair as needed.</li> </ul>

## 6.5 Alarm Detection

HOA Keypad Display	Fault Name
Communication data error occurred due to noise.	<ul style="list-style-type: none"> <li>• Check the various options available to minimize the effects of noise</li> <li>• Counteract noise in the control circuit, main circuit, and ground wiring</li> <li>• Use only recommended cables or other shielded line. Ground the shield on the controller side</li> <li>• Ensure that other equipment such as switches or relays do not cause noise. Use surge suppressors if required</li> <li>• Separate all communication wiring from power lines. When the lines must cross, make the lines cross at a right angle to minimize noise coupling.</li> </ul>
Communication Error timeout time not set properly.	Verify the setting of the serial communications fault time (Z3-06) is set properly.
Controller is not sending data soon enough to stop the timeout.	Verify the scan rate in the controller that is communicating with the bypass controller is proper. Adjust as necessary.

HOA Keypad Display	Minor Fault Name
AL16 <1>	Input Phase Rotation
<b>Cause</b>	<b>Possible Solution</b>
Incorrect phase rotation while Z1-52 is set to 1 in Bypass Mode.	Check the sequence (phase rotation) of the input wiring to the bypass package.

<1> Available in bypass controller software versions VST800298 and later.

HOA Keypad Display	Minor Fault Name
bb	Baseblock
<b>Cause</b>	<b>Possible Solutions</b>
External baseblock signal was entered via one of the multi-function input terminals (S1 to S7)	Check external sequence and baseblock signal input timing.
Connection is broken or master controller stopped communicating	<ul style="list-style-type: none"> <li>• Check for faulty wiring.</li> <li>• Correct the wiring.</li> <li>• Check for disconnected cables and short circuits. Repair as needed.</li> </ul>

HOA Keypad Display	Minor Fault Name
bUS	Option Communication Error
<b>Cause</b>	<b>Possible Solutions</b>
Connection is broken or master controller stopped communicating	<ul style="list-style-type: none"> <li>• Check for faulty wiring.</li> <li>• Correct the wiring.</li> <li>• Check for disconnected cables and short circuits. Repair as needed.</li> </ul>
Option is damaged	If there are no problems with the wiring and the fault continues to occur, replace the option.
The option is not properly connected to the drive	<ul style="list-style-type: none"> <li>• The connector pins on the option are not properly lined up with the connector pins on the drive.</li> <li>• Reinstall the option.</li> </ul>
A data error occurred due to noise	<ul style="list-style-type: none"> <li>• Check options available to minimize the effects of noise.</li> <li>• Take steps to counteract noise in the control circuit wiring, main circuit lines and ground wiring.</li> <li>• Try to reduce noise on the controller side.</li> <li>• Use surge absorbers on magnetic contactors or other equipment causing the disturbance.</li> <li>• Use recommended cables or some other type of shielded line. Ground the shield to the controller side or on the input power side.</li> <li>• Separate the wiring for communication devices from the drive input power lines.</li> </ul>

HOA Keypad Display	Minor Fault Name
CALL	Serial Communication Transmission Error
<b>Cause</b>	<b>Possible Solutions</b>
Communications wiring is faulty, there is a short circuit, or something is not connected properly	<ul style="list-style-type: none"> <li>• Check for wiring errors.</li> <li>• Correct the wiring.</li> <li>• Check for disconnected cables and short circuits. Repair as needed.</li> </ul>
Programming error on the master side	Check communications at start-up and correct programming errors.

HOA Keypad Display	Minor Fault Name
Communications circuitry is damaged	<ul style="list-style-type: none"> <li>Perform a self-diagnostics check.</li> <li>If the problem continues, replace either the control board or the entire drive. For instructions on replacing the control board, contact Yaskawa or your nearest sales representative.</li> </ul>
Termination resistor setting is incorrect	Install a termination resistor at both ends of a communication line. Set the internal termination resistor switch correctly on slave drives. Place DIP switch S2 to the ON position.

HOA Keypad Display	Minor Fault Name
CE	MEMOBUS/Modbus Communication Error
	Control data was not received correctly for two seconds.
Cause	Possible Solutions
A data error occurred due to noise	<ul style="list-style-type: none"> <li>Check options available to minimize the effects of noise.</li> <li>Take steps to counteract noise in the control circuit wiring, main circuit lines, and ground wiring.</li> <li>Reduce noise on the controller side.</li> <li>Use surge absorbers for the magnetic contactors or other components that may be causing the disturbance.</li> <li>Use only recommended shielded line. Ground the shield on the controller side or on the drive input power side.</li> <li>Separate all wiring for communication devices from drive input power lines.</li> </ul>
Communication protocol is incompatible	<ul style="list-style-type: none"> <li>Check the Z3 parameter settings and the protocol setting in the controller.</li> <li>Ensure settings are compatible.</li> </ul>
The CE detection time (H5-09) is set shorter than the time required for a communication cycle to take place	<ul style="list-style-type: none"> <li>Check the PLC.</li> <li>Change the software settings in the PLC.</li> <li>Set a longer CE detection time using parameter Z3-06.</li> </ul>
Incompatible PLC software settings or there is a hardware problem	<ul style="list-style-type: none"> <li>Check the PLC.</li> <li>Remove the cause of the error on the controller side.</li> </ul>
Communications cable is disconnected or damaged	<ul style="list-style-type: none"> <li>Check the connector to make sure the cable has a signal.</li> <li>Replace the communications cable.</li> </ul>

HOA Keypad Display	Minor Fault Name
CrST	Cannot Reset
Cause	Possible Solutions
Fault reset was being executed when a Run command was entered	<ul style="list-style-type: none"> <li>Ensure that a Run command cannot be entered from the external terminals or option during fault reset.</li> <li>Turn off the Run command.</li> </ul>

HOA Keypad Display	Minor Fault Name
EF	Forward/Reverse Run Command Input Error
	Both forward run and reverse run closed simultaneously for longer than 0.5 s.
Cause	Possible Solutions
Sequence error	<p>Check the forward and reverse command sequence and correct the problem.</p> <p><b>Note:</b> When minor fault EF detected, motor ramps to stop.</p>

HOA Keypad Display	Minor Fault Name
EF0	Option Card External Fault
	An external fault condition is present.
Cause	Possible Solutions
An external fault was received from the PLC with F6-03 set to 3, which allows the drive to continue running after an external fault occurs	<ul style="list-style-type: none"> <li>Remove the cause of the external fault.</li> <li>Remove the external fault input from the PLC.</li> </ul>
There is a problem with the PLC program	Check the PLC program and correct problems.

HOA Keypad Display	Minor Fault Name
FbH	Excessive PI Feedback
	The PI feedback input is higher than the level set to b5-36 for longer than the time set to b5-37, and b5-12 is set to 1 or 4.
Cause	Possible Solutions

## 6.5 Alarm Detection

HOA Keypad Display	Minor Fault Name
Parameter settings for b5-36 and b5-37 are incorrect	Check parameters b5-36 and b5-37.
PI feedback wiring is faulty	Correct the wiring.
Feedback sensor has malfunctioned	Check the sensor and replace it if damaged.
Feedback input circuit is damaged	Replace either the control board or the entire drive. For instructions on replacing the control board, contact Yaskawa or your nearest sales representative.

HOA Keypad Display	Minor Fault Name
FbL	PI Feedback Loss
	The PI feedback input is lower than the level set to b5-13 for longer than the time set to b5-14, and b5-12 is set to 1 or 4.
<b>Cause</b>	<b>Possible Solutions</b>
Parameter settings for b5-13 and b5-14 are incorrect	Check parameters b5-13 and b5-14.
PI feedback wiring is faulty	Correct the wiring.
Feedback sensor has malfunctioned	Check the sensor and replace it if damaged.
Feedback input circuit is damaged	Replace either the control board or the entire drive. For instructions on replacing the control board, contact Yaskawa or your nearest sales representative.

HOA Keypad Display	Minor Fault Name
HCA	Current Alarm
	Drive current exceeded overcurrent warning level (150% of the rated current).
<b>Cause</b>	<b>Possible Solutions</b>
Load is too heavy	Reduce the load for applications with repetitive operations (i.e., stops and starts), or replace the drive.
Acceleration and deceleration times are too short	<ul style="list-style-type: none"> <li>Calculate the torque required during acceleration and for the inertia moment.</li> <li>If the torque level is not right for the load, take the following steps:</li> <li>Increase the acceleration and deceleration times (C1-01 to C1-04).</li> <li>Increase the capacity of the drive.</li> </ul>
A special-purpose motor is being used, or the drive is attempting to run a motor greater than the maximum allowable capacity	<ul style="list-style-type: none"> <li>Check the motor capacity.</li> <li>Use a motor appropriate for the drive. Ensure the motor is within the allowable capacity range.</li> </ul>
The current level increased due to Speed Search after a momentary power loss or while attempting to perform a fault restart	The alarm will only appear briefly. There is no need to take action to prevent the alarm from occurring in such instances.

HOA Keypad Display	Minor Fault Name
inTLK	Interlock Open
	ALM LED will not blink
<b>Cause</b>	<b>Possible Solutions</b>
BAS Interlock multi-function input is open	Check the cause of interlock.

HOA Keypad Display	Minor Fault Name
LT-1	Cooling Fan Maintenance Time
	The cooling fan has reached its expected maintenance period and may need to be replaced.
<b>Cause</b>	<b>Possible Solutions</b>
The cooling fan has reached 90% of its expected performance life	Replace the cooling fan and set o4-03 to 0 to reset the Maintenance Monitor.

HOA Keypad Display	Minor Fault Name
LT-2	Capacitor Maintenance Time
	The main circuit and control circuit capacitors are nearing the end of their expected performance life.
<b>Cause</b>	<b>Possible Solutions</b>
The main circuit and control circuit capacitors have reached 90% of their expected performance lives	Replace either the control board or the entire drive. For instructions on replacing the control board, contact Yaskawa or your nearest sales representative.



HOA Keypad Display	Minor Fault Name
LT-3	Soft Charge Bypass Relay Maintenance Time
	The DC bus soft charge relay is nearing the end of its expected performance life.
<b>Cause</b>	<b>Possible Solutions</b>
The DC bus soft charge relay has reached 90% of expected performance life	Replace either the control board or the entire drive. For instructions on replacing the control board, contact Yaskawa or your nearest sales representative.

HOA Keypad Display	Minor Fault Name
LT-4	IGBT Maintenance Time (50%)
	IGBTs have reached 50% of their expected performance life.
<b>Cause</b>	<b>Possible Solutions</b>
IGBTs have reached 50% of their expected performance life	Check the load, carrier frequency, and output frequency.

HOA Keypad Display	Minor Fault Name
oH	Heatsink Overheat
	The temperature of the heatsink exceeded the overheat pre-alarm level set to L8-02 (90-100 °C). Default value for L8-02 is determined by drive capacity (o2-04).
<b>Cause</b>	<b>Possible Solutions</b>
Surrounding temperature is too high	<ul style="list-style-type: none"> <li>Check the surrounding temperature.</li> <li>Improve the air circulation within the enclosure panel.</li> <li>Install a fan or air conditioner to cool surrounding area.</li> <li>Remove anything near drive that may cause extra heat.</li> </ul>
Internal cooling fan has stopped	<ul style="list-style-type: none"> <li>Replace the cooling fan.</li> <li>After replacing the drive, set parameter o4-03 to 0 to reset the cooling fan operation time.</li> </ul>
Airflow around the drive is restricted	<ul style="list-style-type: none"> <li>Provide proper installation space around the drive as indicated in the manual. <i>Refer to Installation Orientation and Spacing on page 41</i> for details.</li> <li>Allow for the proper space and ensure that there is sufficient circulation around the control panel.</li> <li>Check for dust or other foreign materials clogging the cooling fan.</li> <li>Clear debris caught in the fan that restricts air circulation.</li> </ul>

HOA Keypad Display	Minor Fault Name
oH2	Drive Overheat Warning
<b>Cause</b>	<b>Possible Solutions</b>
An external device triggered an overheat warning in the drive	Search for the device that tripped the overheat warning. Remove the cause of the problem.

HOA Keypad Display	Minor Fault Name
oH3	Motor Overheat
	The motor overheat signal entered to a multi-function analog input terminal exceeded the alarm level (H3-02 or H3-10 = E).
<b>Cause</b>	<b>Possible Solutions</b>
Motor thermostat wiring is faulty (PTC input).	Repair the PTC input wiring.
There is a fault on the machine side (e.g., the machine is locked up)	<ul style="list-style-type: none"> <li>Check the status of the machine.</li> <li>Remove the cause of the fault.</li> </ul>
Motor has overheated	<ul style="list-style-type: none"> <li>Check the load size, accel/decel times, and cycle times.</li> <li>Decrease the load.</li> <li>Increase accel and decel times (C1-01 and C1-02).</li> <li>Adjust the preset V/f pattern. Set E1-03 to 6.</li> <li>Check the motor-rated current.</li> <li>Enter motor-rated current on motor nameplate (E2-01).</li> <li>Ensure the motor cooling system is operating normally.</li> <li>Repair or replace the motor cooling system.</li> </ul>

HOA Keypad Display	Minor Fault Name
oL3	Overtorque 1
	Drive output current was greater than L6-02 for longer than the time set to L6-03.

## 6.5 Alarm Detection

HOA Keypad Display	Minor Fault Name
Cause	Possible Solutions
Inappropriate parameter settings	Check parameters L6-02 and L6-03.
There is a fault on the machine side (e.g., the machine is locked up)	<ul style="list-style-type: none"> <li>• Check the status of the machine.</li> <li>• Remove the cause of the fault.</li> </ul>

HOA Keypad Display	Minor Fault Name
ov	DC Bus Overvoltage The DC bus voltage exceeded the trip point. <ul style="list-style-type: none"> <li>• For 208 V: approximately 410 V</li> <li>• For 480 V: approximately 820 V</li> </ul>
Cause	Possible Solutions
Surge voltage present in the drive input power	<ul style="list-style-type: none"> <li>• Install an AC reactor.</li> <li>• Voltage surge can result from a thyristor convertor and a phase advancing capacitor operating on the same drive input power system.</li> </ul>
The motor is short-circuited	<ul style="list-style-type: none"> <li>• Check the motor power cable, relay terminals and motor terminal box for short circuits.</li> <li>• Correct grounding shorts and turn the power back on.</li> </ul>
Ground current has overcharged the main circuit capacitors via the drive input power	
Noise interference causes the drive to operate incorrectly	<ul style="list-style-type: none"> <li>• Review possible solutions for handling noise interference.</li> <li>• Review section on handling noise interference and check control circuit lines, main circuit lines and ground wiring.</li> <li>• If the magnetic contactor is identified as a source of noise, install a surge protector to the MC coil.</li> </ul>
	Set number of fault restarts (L5-01) to a value other than 0.

HOA Keypad Display	Minor Fault Name
PASS	MEMOBUS/Modbus Comm. Test Mode Complete
Cause	Possible Solutions
MEMOBUS/Modbus test has finished normally	This verifies that the test was successful.

HOA Keypad Display	Minor Fault Name
SAFE	Customer Safety Customer Safeties mult-function input is open. This alarm has display priority over the Interlock Open (inTLK).
Cause	Possible Solutions
External contact from customer wiring is open.	Check the cause of the open safety.

HOA Keypad Display	Minor Fault Name
SE	MEMOBUS/Modbus Communication Test Mode Error
Cause	Possible Solutions
A digital input set to 67H (MEMOBUS/Modbus test) was closed while the drive was running	Stop the drive and run the test again.

HOA Keypad Display	Minor Fault Name
TrPC	IGBT Maintenance Time (90%) IGBTs have reached 90% of their expected performance life.
Cause	Possible Solutions
IGBTs have reached 90% of their expected performance life	Replace the drive.

HOA Keypad Display	Minor Fault Name
UL3	Undertorque Detection 1 Drive output current less than L6-02 for longer than L6-03 time.
Cause	Possible Solutions
Inappropriate parameter settings	Check parameters L6-02 and L6-03.
Load has dropped or decreased significantly	Check for broken parts in the transmission system.

HOA Keypad Display	Minor Fault Name
UL6	Undertorque Detection 6
Cause	Possible Solutions
The load has dropped or decreased under the motor underload curve	Check parameters L6-13 and L6-14.

HOA Keypad Display	Minor Fault Name
Uv	Undervoltage
	One of the following conditions was true when the drive was stopped and a Run command was entered: <ul style="list-style-type: none"> <li>DC bus voltage dropped below the level specified in L2-05.</li> <li>Contactor to suppress inrush current in the drive was opened.</li> <li>Low voltage in the control drive input power. This alarm outputs only if L2-01 is not 0 and DC bus voltage is under L2-05.</li> </ul>
Cause	Possible Solutions
Phase loss in the drive input power	Check for wiring errors in the main circuit drive input power. Correct the wiring.
Loose wiring in the drive input power terminals	<ul style="list-style-type: none"> <li>Ensure the terminals have been properly tightened.</li> <li>Apply the tightening torque to the terminals as specified. <i>Refer to Wire Gauge and Tightening Torque Specifications on page 62.</i></li> </ul>
There is a problem with the drive input power voltage	<ul style="list-style-type: none"> <li>Check the voltage.</li> <li>Lower the voltage of the drive input power so that it is within the limits listed in the specifications.</li> </ul>
Drive internal circuitry is worn	<ul style="list-style-type: none"> <li>Check the maintenance time for the capacitors (U4-05).</li> <li>Replace either the control board or the entire drive if U4-05 exceeds 90%. For instructions on replacing the control board, contact Yaskawa or your nearest sales representative.</li> </ul>
The drive input power transformer is too small and voltage drops when the power is switched on	<ul style="list-style-type: none"> <li>Check for an alarm when the magnetic contactor, line breaker, and leakage breaker are closed.</li> <li>Check the capacity of the drive input power transformer.</li> </ul>
Air inside the drive is too hot	Check the temperature inside the drive.
The CHARGE light is broken or disconnected	Replace either the control board or the entire drive. For instructions on replacing the control board, contact Yaskawa or your nearest sales representative.

HOA Keypad Display	Minor Fault Name
voF	Output Voltage Detection Fault
	There is a problem with the output voltage.
Cause	Possible Solutions
Hardware is damaged	Replace either the control board or the entire drive. For instructions on replacing the control board, contact Yaskawa or your nearest sales representative.

HOA Keypad Display	Minor Fault Name
WrUn	Waiting for Run
	A Run command has been issued and the drive is waiting to begin running the motor.
Cause	Possible Solutions
After a Run command has been entered, the drive must wait for the time set to b1-11 to pass before it can begin to operate the motor	This is not an error.

## 6.6 Programming Errors

### ◆ Programming Error Codes, Causes, and Possible Solutions

A Programming Error (oPE) occurs when a contradictory parameter is set or an individual parameter is set to an inappropriate value.

The drive will not operate until the parameter or parameters causing the problem are set correctly. An oPE, however, does not trigger an alarm or fault output. If an oPE occurs, investigate the cause and refer to [Table 6.10](#) for the appropriate action. When an oPE appears on the HOA keypad display, press the ENTER button to view U1-18 and see which parameter is causing the oPE.

**Table 6.10 oPE Codes, Causes, and Possible Solutions**

HOA Keypad Display	Error Name
oPE01	Drive Capacity Setting Fault
	Drive capacity and the value set to o2-04 do not match.
<b>Cause</b>	<b>Possible Solutions</b>
The drive model selection (o2-04) and the actual capacity of the drive are not the same	Correct the value set to o2-04.

HOA Keypad Display	Error Name
oPE02	Parameter Range Setting Error
	Use U1-18 to find parameters set outside the range.
<b>Cause</b>	<b>Possible Solutions</b>
Parameters were set outside the possible setting range	<ul style="list-style-type: none"> <li>Set parameters to the proper values by checking the modified constants menu and verifying that settings are within the limits.</li> <li>Set Z1-01 to 1 to re-initialize the drive and bypass.</li> </ul> Set parameters to the proper values by checking the modified constants menu and verifying that settings are within the limits.
<b>Note:</b>	When multiple errors occur simultaneously, other errors are given precedence over oPE02

HOA Keypad Display	Error Name
oPE03	Multi-Function Input Selection Error
	A contradictory setting is assigned to multi-function contact inputs Z2-01 to Z2-08.
<b>Cause</b>	<b>Possible Solutions</b>
<ul style="list-style-type: none"> <li>The same function is assigned to two multi-function inputs</li> <li>Excludes “Not used” and “External Fault”</li> </ul> Settings for N.C. and N.O. input for the following functions were selected simultaneously: <ul style="list-style-type: none"> <li>External Search Command 1 and External Search Command 2 (61 vs. 62)</li> <li>Fast Stop N.O. and Fast Stop N.C. (15 vs. 17)</li> <li>KEB for Momentary Power Loss and High Slip Braking (65, 66, 7A, 7B vs. 68)</li> <li>KEB Command 1 and KEB Command 2 (65, 66 vs. 7A, 7B)</li> <li>FWD Run Command (or REV) and FWD/REV Run Command (2-wire) (40, 41 vs. 42, 43)</li> <li>Drive Enable (60 vs. 6A)</li> </ul>	<ul style="list-style-type: none"> <li>Ensure all multi-function inputs are assigned to different functions.</li> <li>Re-enter the multi-function settings to ensure this does not occur.</li> </ul> Check if contradictory settings have simultaneously been assigned to the multi-function input terminals. <ul style="list-style-type: none"> <li>Correct setting errors.</li> </ul>

HOA Keypad Display	Error Name
oPE05	Run Command/Frequency Reference Source Selection Error
<b>Cause</b>	<b>Possible Solutions</b>
Frequency reference is assigned to an option card (Z1-07) and an input option card is not connected to the drive	Reconnect the input option card to the drive.
The Run command is assigned to an option card (Z1-08) and an input option card is not connected to the drive	

HOA Keypad Display	Error Name
oPE07	Multi-Function Analog Input Selection Error
<b>Cause</b>	<b>Possible Solutions</b>
A contradictory setting is assigned to multi-function analog inputs H3-02 or H3-10 and PI functions conflict.	Change the settings to H3-02 and H3-10 so that functions no longer conflict. <b>Note:</b> Both 0 (Frequency Reference Bias) and F (Not Used) can be set to H3-02 and H3-10 simultaneously.
At least two analog input terminals are set to the same function (i.e., at least two of these parameters have the same setting: H3-02 or H3-10)	
The following simultaneous contradictory settings: H3-02 or H3-10 = C (PI Target Value) while b5-18 = 1 (enables b5-19 as the target PI value)	Disable one of the PI selections.

HOA Keypad Display	Error Name
oPE09	PI Control Selection Fault
<b>Cause</b>	<b>Possible Solutions</b>
PI control function selection is incorrect. Requires that PI control is enabled (b5-01 = 1 or 3).	<ul style="list-style-type: none"> <li>Set b5-15 to a value other than 0.0.</li> <li>Set the stopping method to coast to stop or ramp to stop (b1-03 = 0 or 1).</li> </ul>
The following simultaneous contradictory settings have occurred: <ul style="list-style-type: none"> <li>b5-15 is not set to 0.0 (PI Sleep Function Operation Level)</li> <li>The stopping method is set to either DC Injection Braking or coast to stop with a timer (b1-03 = 2 or 3)</li> </ul>	
b5-01 is set to 1, enabling PI control, but the lower limit for the frequency reference (d2-02) is not set to 0 while reverse output is enabled (b5-11 = 1)	Correct the parameter settings.
b5-01 is set to 3, enabling PI control, but the lower limit for the frequency reference (d2-01) is not 0. Parameter d2-01 is not accessible.	Correct the parameter settings.

HOA Keypad Display	Error Name
oPE10	V/f Data Setting Error
<b>Cause</b>	<b>Possible Solutions</b>
V/f pattern setting error	Set E1-03 to the pattern that fits the application.

HOA Keypad Display	Error Name
oPE11	Carrier Frequency Setting Error
<b>Cause</b>	<b>Possible Solutions</b>
The following simultaneous contradictory settings have occurred: C6-05 > 6 and C6-04 > C6-03 (carrier frequency lower limit is greater than the upper limit) If C6-05 ≤ 6, the drive operates at C6-03 <1>	Correct the parameter settings.
The upper and lower limits between C6-02 and C6-05 are contradictory	

<1> Details on this function can be found in the standard Z1000 Programming Manual (SIEPC71061645) at [www.yaskawa.com](http://www.yaskawa.com).

## 6.6 Programming Errors

HOA Keypad Display	Error Name
oPE28	Sequence Timer Error
	One or more of the sequence timers is not set in the correct order.
Cause	Possible Solutions
One of the following contradictory settings is true: <ul style="list-style-type: none"> <li>• S2-01 &gt; S2-02</li> <li>• S2-06 &gt; S2-07</li> <li>• S2-11 &gt; S2-12</li> <li>• S2-16 &gt; S2-17</li> </ul>	Correct the parameter settings.

HOA Keypad Display	Error Name
oPE29	Baud Rate Setting Error
	The baud rate setting (H5-02) is not compatible with currently selected protocol (H5-08).
Cause	Possible Solutions
One of the following contradictory settings is true: <ul style="list-style-type: none"> <li>• H5-08 = 1 and H5-02 ≠ 3</li> <li>• H5-08 = 2 and H5-02 ≠ 2, 3</li> <li>• H5-08 = 3 and H5-02 ≠ 3, 4, 5, 7</li> </ul>	Correct the parameter settings.

## 6.7 Auto-Tuning Fault Detection

When the Auto-Tuning faults shown below are detected, the fault is displayed on the operator and the motor coasts to a stop. Auto-Tuning faults do not trigger a multi-function terminal set for fault or alarm output.

An End□ error indicates that although Auto-Tuning has successfully completed, there is some discrepancy in the calculations. If an End□ error occurs, check for the cause of the error using the table in this section, and perform Auto-Tuning again or manually set the motor parameters after fixing the problem. Start the application if no problem can be diagnosed despite the existence of the End□ error.

### ◆ Auto-Tuning Codes, Causes, and Possible Solutions

Table 6.11 Auto-Tuning Codes, Causes, and Possible Solutions

HOA Keypad Display	Error Name
End3	Rated Current Setting Alarm (displayed after Auto-Tuning is complete)
<b>Cause</b>	<b>Possible Solutions</b>
The correct current rating printed on the motor nameplate was not entered into T1-04	<ul style="list-style-type: none"> <li>• Check the setting of parameter T1-04.</li> <li>• Check the motor data and repeat Auto-Tuning.</li> </ul>
HOA Keypad Display	Error Name
End4	Adjusted Slip Calculation Error
<b>Cause</b>	<b>Possible Solutions</b>
The calculated slip is outside the allowable range	Make sure the data entered for Auto-Tuning is correct.
HOA Keypad Display	Error Name
End5	Resistance Tuning Error
<b>Cause</b>	<b>Possible Solutions</b>
The calculated resistance value is outside the allowable range	<ul style="list-style-type: none"> <li>• Double-check the data entered for the Auto-Tuning process.</li> <li>• Check the motor and motor cable connection for faults.</li> </ul>
HOA Keypad Display	Error Name
End7	No-Load Current Alarm
<b>Cause</b>	<b>Possible Solutions</b>
The entered no-load current value was outside the allowable range	Check and correct faulty motor wiring.
Auto-Tuning results were less than 5% of the motor rated current	Double-check the data entered for the Auto-Tuning process.
HOA Keypad Display	Error Name
Er-01	Motor Data Error
<b>Cause</b>	<b>Possible Solutions</b>
Motor data or data entered during Auto-Tuning was incorrect	<ul style="list-style-type: none"> <li>• Check that the motor data entered to T1 parameters matches motor nameplate input before Auto-Tuning.</li> <li>• Restart Auto-Tuning and enter the correct information.</li> </ul>
Motor output power and motor-rated current settings (T1-02 and T1-04) do not match	<ul style="list-style-type: none"> <li>• Check the drive and motor capacities.</li> <li>• Correct the settings of parameters T1-02 and T1-04.</li> </ul>
Motor rated current and detected no-load current are inconsistent	<ul style="list-style-type: none"> <li>• Check the motor rated current and no-load current.</li> <li>• Correct the settings of parameters T1-04 and E2-03.</li> </ul>
Base frequency and motor rated speed (T1-05 and T1-07) do not match	<ul style="list-style-type: none"> <li>• Correct the settings of parameters T1-05 and T1-07.</li> <li>• Check that the correct number of poles were entered to T1-06.</li> </ul>
HOA Keypad Display	Error Name
Er-02	Minor Fault
<b>Cause</b>	<b>Possible Solutions</b>
An alarm was triggered during Auto-Tuning	Exit the Auto-Tuning menu, check the alarm code, remove the alarm cause, and repeat Auto-Tuning.

## 6.7 Auto-Tuning Fault Detection

HOA Keypad Display	Error Name
Er-03	OFF Button Input
Cause	Possible Solutions
Auto-Tuning canceled by pressing the OFF button	Auto-Tuning did not complete properly. Restart Auto-Tuning.

HOA Keypad Display	Error Name
Er-04	Line-to-Line Resistance Error
Cause	Possible Solutions
Motor data entered during Auto-Tuning was incorrect	<ul style="list-style-type: none"> <li>Make sure the data entered to the T1 parameters match the information written on the motor nameplate.</li> <li>Restart Auto-Tuning and enter the correct information.</li> </ul>
Results from Auto-Tuning are outside the parameter setting range or the tuning process took too long	Check and correct faulty motor wiring.
Faulty motor cable or cable connection	

HOA Keypad Display	Error Name
Er-05	No-Load Current Error
Cause	Possible Solutions
Motor data entered during Auto-Tuning was incorrect	<ul style="list-style-type: none"> <li>Make sure the data entered to the T1 parameters match the information written on the motor nameplate.</li> <li>Restart Auto-Tuning and enter the correct information.</li> </ul>
Results from Auto-Tuning are outside the parameter setting range or the tuning process took too long	Check and correct faulty motor wiring.

HOA Keypad Display	Error Name
Er-08	Rated Slip Error
Cause	Possible Solutions
Motor data entered during Auto-Tuning was incorrect	<ul style="list-style-type: none"> <li>Make sure the data entered to the T1 parameters match the information written on the motor nameplate.</li> <li>Restart Auto-Tuning and enter the correct information.</li> </ul>
Results from Auto-Tuning are outside the parameter setting range or the tuning process took too long	Check and correct faulty motor wiring.

HOA Keypad Display	Error Name
Er-09	Acceleration Error
Cause	Possible Solutions
The motor did not accelerate for the specified acceleration time	<ul style="list-style-type: none"> <li>Increase the acceleration time (C1-01).</li> <li>Disconnect the machine from the motor if possible.</li> </ul>

HOA Keypad Display	Error Name
Er-12	Current Detection Error
Cause	Possible Solutions
One of the motor phases is missing: (U/T1, V/T2, W/T3)	Check motor wiring and correct any problems.
The current exceeded the current rating of the drive	<ul style="list-style-type: none"> <li>Check motor wiring for a short between motor lines.</li> <li>Close any magnetic contactors used between motors.</li> <li>Replace the control board or the entire drive. For instructions on replacing the control board, contact Yaskawa or your nearest sales representative.</li> </ul>
The current is too low	
Attempted Auto-Tuning without motor connected to the drive	Connect the motor and restart Auto-Tuning.
Current detection signal error	Replace the control board or the entire drive. For instructions on replacing the control board, contact Yaskawa or your nearest sales representative.



## 6.8 Diagnosing and Resetting Faults

When a fault occurs and the drive stops, follow the instructions below to remove whatever conditions triggered the fault, then restart the drive.

**Note:** An oC/SC fault will be displayed in the event of an IGBT failure. It may not be possible to reset this fault until the IGBT problem is corrected.

### ◆ Fault Occurs Simultaneously with Power Loss

**WARNING! Electrical Shock Hazard.** Ensure there are no short circuits between the main circuit terminals (R/L1, S/L2, and T/L3) or between the ground and main circuit terminals before restarting the drive. Failure to comply may result in serious injury or death and will cause damage to equipment.

1. Turn on the drive input power.
2. Use monitor parameters U2-□□ to display data on the operating status of the drive just before the fault occurred.
3. Remove the cause of the fault and reset.

**Note:**

1. To find out what faults were triggered, check the fault history in U2-02. Information on drive status when the fault occurred such as the frequency, current, and voltage can be found in U2-03 through U2-32. [Refer to Viewing Fault Trace Data After Fault on page 257](#) for information on how to view fault data.
2. When the fault continues to be displayed after cycling power, remove the cause of the fault and reset.

### ◆ If the Drive Still has Power After a Fault Occurs



1. Look at the HOA keypad for information on the fault that occurred.
2. [Refer to Fault Displays, Causes, and Possible Solutions on page 229.](#)
3. Reset the fault. [Refer to Fault Reset Methods on page 258.](#)

### ◆ Viewing Fault Trace Data After Fault

Step		Display/Result
1. Turn on the drive input power. The first screen displays.	→	
2. Press  or  until the monitor screen is displayed.	→	
3. Press  to display the parameter setting screen.	→	
4. Press  and  to scroll to monitor U2-02. The fault code shown in U2-02 is the fault that occurred most recently.	→	
5. Press  to view drive status information when fault occurred. Parameters U2-03 through U2-32 help determine the cause of a fault. Parameters to be monitored differ depending on the control mode.	→	

### ◆ Fault Reset Methods

When a fault occurs, the cause of the fault must be removed and the drive must be restarted. The table below lists the different ways to restart the drive.

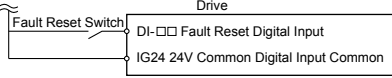
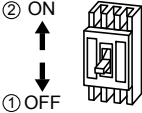
After the Fault Occurs	Procedure	
Fix the cause of the fault, restart the drive, and reset the fault	Press  on the HOA keypad.	
Resetting via Fault Reset Digital Input DI-□□ Resetting via Fault Reset serial command.	Close then open the fault signal digital input via the digital input defined as Fault Reset (one of Z2-01 through Z2-08 set to 34).	
Turn off the main power supply if the above methods do not reset the fault. Reapply power after the HOA keypad display has turned off. When an “SC” error occurs, contact Yaskawa or a Yaskawa agent before cycling the power to the drive.		

**Note:** If the Run command is present, the drive will disregard any attempts to reset the fault. Remove the Run command or press “OFF” on the HOA keypad before attempting to clear a fault situation.

## 6.9 Troubleshooting without Fault Display

This section describes troubleshooting problems that do not trip an alarm or fault.



The following symptoms indicate that the drive is not set correctly for proper performance with the motor. *Refer to Motor Performance Fine-Tuning on page 224* for guidance on troubleshooting.

- Motor hunting and oscillation
- Poor motor torque
- Poor speed precision
- Poor motor torque and speed response
- Motor noise

### ◆ Common Problems

Common Problems		Page
Cannot Change Parameter Settings		259
Motor Does Not Rotate Properly after Pressing the AUTO Button or after Entering External Run Command	Motor Does Not Rotate	260
	Motor Rotates in the Opposite Direction from the Run Command	261
	Motor Rotates in One Direction Only	261
Motor is Too Hot		261
oPE02 Error Occurs When Lowering the Motor Rated Current Setting		262
Motor Stalls During Acceleration or With Large Loads		262
Drive Frequency Reference Differs from the Controller Frequency Reference Command		262
Excessive Motor Oscillation and Erratic Rotation		263
Deceleration Takes Longer Than Expected		263
Noise From Drive or Motor Cables When the Drive is Powered On		263
Ground Fault Circuit Interrupter (GFCI) Trips During Run		263
Connected Machinery Vibrates When Motor Rotates	Unexpected Noise from Connected Machinery	263
	Oscillation or Hunting	264
PI Output Fault		264
Motor Rotates After the Drive Output is Shut Off (Motor Rotates During DC Injection Braking)		264
Output Frequency is not as High as Frequency Reference		264
Sound from Motor		264
Motor Does Not Restart after Power Loss		265

### ◆ Cannot Change Parameter Settings





Cause	Possible Solutions
The drive is running the motor (i.e., the Run command is present).	<ul style="list-style-type: none"> <li>• Stop the drive and switch over to the Programming Mode.</li> <li>• Most parameters cannot be edited during run.</li> </ul>
The operator is not in the Parameter Setup Mode (the screen will display “PAR”).	<ul style="list-style-type: none"> <li>• See what mode the operator is currently set for.</li> <li>• Parameters cannot be edited when in the Setup Mode (“STUP”). Switch modes so that “PAR” appears on the screen. <i>Refer to The Drive and Programming Modes on page 99.</i></li> </ul>
A multi-function contact input terminal is set to allow or restrict parameter editing (H1-01 through H1-07 = 1B).	<ul style="list-style-type: none"> <li>• When the terminal is open, parameters cannot be edited.</li> <li>• Turn on the multi-function contact input set to 1B.</li> </ul>
The wrong password was entered.	<ul style="list-style-type: none"> <li>• If the password entered to A1-04 does not match the password saved to A1-05, then drive settings cannot be changed.</li> <li>• Reset the password.</li> </ul> <p>If you cannot remember the password:</p> <ul style="list-style-type: none"> <li>• Scroll to Z1-02. Press  and  simultaneously. Parameter Z1-03 will appear.</li> <li>• Set a new password to parameter Z1-03.</li> </ul>

## 6.9 Troubleshooting without Fault Display

Cause	Possible Solutions
Undervoltage was detected.	<ul style="list-style-type: none"> <li>• Check the drive input power voltage by looking at the DC bus voltage (U1-07).</li> <li>• Check all main circuit wiring.</li> </ul>

### ◆ Motor Does Not Rotate Properly after Pressing AUTO Button or after Entering External Run Command

#### ■ Motor Does Not Rotate

Cause	Possible Solutions
The drive is not in the Drive Mode.	<ul style="list-style-type: none"> <li>• Check if the DRV light on the HOA keypad is lit.</li> <li>• Enter the Drive Mode to begin operating the motor. <i>Refer to The Drive and Programming Modes on page 99.</i></li> </ul>
 was pushed.	<p>Stop the drive and check if the correct frequency reference source is selected. If the operator keypad shall be the source, the LO/RE button LED must be on. If the source is REMOTE, it must be off.</p> <p>Take the following steps to solve the problem:</p> <ul style="list-style-type: none"> <li>• Push .</li> </ul>
Auto-Tuning has just completed.	<ul style="list-style-type: none"> <li>• When Auto-Tuning completes, the drive is switched back to the Programming Mode. The Run command will not be accepted unless the drive is in the Drive Mode.</li> <li>• Use the HOA keypad to enter the Drive Mode. <i>Refer to The Drive and Programming Modes on page 99.</i></li> </ul>
A Fast Stop was executed and has not yet been reset.	Reset the Fast Stop command.
Settings are incorrect for the source that provides the Run command.	<p>Check parameter Z1-08 (Run Command Selection). Set Z1-08 so that it corresponds with the correct Run command source.</p> <p>0: HOA keypad 1: Control circuit terminal (default setting) 2: MEMOBUS/Modbus communications 3: Option card</p>
There is faulty wiring in the control circuit terminals.	<ul style="list-style-type: none"> <li>• Check the wiring for the control terminal.</li> <li>• Correct wiring mistakes.</li> <li>• Check the input terminal status monitor (U1-10).</li> </ul>
The drive has been set to accept the frequency reference from the incorrect source.	<p>Check parameter b1-01 (Frequency Reference Selection 1). Set b1-01 to the correct source of the frequency reference.</p> <p>0: HOA keypad 1: Control circuit terminal (default setting) 2: MEMOBUS/Modbus communications 3: Option card</p>
The terminal set to accept the main speed reference is set to the incorrect voltage and/or current.	If the frequency reference is set at terminal A1, check parameter H3-01 for the correct signal level selection. If terminal A2 is used, check parameter H3-09. <i>Refer to Input Signal Selection for Terminals A1 and A2 on page 85.</i>
Selection for the sink/source mode and the internal/external power supply is incorrect.	Check wire jumper connection between terminals SC and SP.
Frequency reference is too low.	Check the frequency reference monitor (U1-01).
Multi-function analog input is set up to accept gain for the frequency reference, but no voltage (current) has been provided.	<ul style="list-style-type: none"> <li>• Check the multi-function analog input settings.</li> <li>• Check if analog inputs A1 or A2 are set for frequency reference gain (H3-02, H3-10 = 1). If so, check if the correct signal is applied to the terminal. The gain and the frequency reference will be 0 if no signal is applied to the gain input.</li> <li>• Check if H3-02 and H3-10 have been set to the proper values.</li> <li>• Check if the analog input value has been set properly. (U1-13 and U1-14)</li> </ul>
 was pressed when the drive was started from a REMOTE source.	<ul style="list-style-type: none"> <li>• Pressing  will decelerate the drive to stop.</li> <li>• Switch off the Run command and then re-enter a new Run command.</li> <li>• Set o2-02 to 0 to disable .</li> </ul>
Motor starting torque is too low.	<i>Refer to Motor Performance Fine-Tuning on page 224.</i>
Frequency reference value is too low or the drive does not accept the value entered.	Enter a value that is above the minimum output frequency determined by E1-09.

■ Motor Rotates in the Opposite Direction from the Run Command

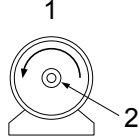
Cause	Possible Solutions
Phase wiring between the drive and motor is incorrect.	<ul style="list-style-type: none"> <li>• Check the motor wiring.</li> <li>• Switch two motor cables (U, V, and W) to reverse motor direction.</li> <li>• Connect drive output terminals U/T1, V/T2, and W/T3 in the right order to match motor terminals U, V, and W.</li> <li>• Change the setting of parameter b1-14.</li> </ul>
The forward direction for the motor is set up incorrectly.	<p>Typically, forward is designated as being counterclockwise when looking from the motor shaft (see figure below).</p>  <p>1. Forward Rotating Motor (looking down the motor shaft) 2. Motor Shaft</p>
The motor is running at almost 0 Hz and the Speed Search estimated the speed to be in the opposite direction.	<ul style="list-style-type: none"> <li>• Disable bi-directional search (b3-14 = 0) so that Speed Search is performed only in the specified direction.</li> </ul>

**Note:** Check the motor specifications for the forward and reverse directions. The motor specifications will vary depending on the manufacturer of the motor.

■ Motor Rotates in One Direction Only

Cause	Possible Solutions
The drive prohibits reverse rotation.	<ul style="list-style-type: none"> <li>• Check parameter b1-04.</li> <li>• Set parameter b1-04 to 0 to allow the motor to rotate in reverse.</li> </ul>

◆ Motor is Too Hot

Cause	Possible Solutions
The load is too heavy.	<p>If the load is too heavy for the motor, the motor will overheat as it exceeds its rated torque value for an extended period of time. Keep in mind that the motor also has a short-term overload rating in addition to the possible solutions provided below:</p> <ul style="list-style-type: none"> <li>• Reduce the load.</li> <li>• Increase the acceleration and deceleration times.</li> <li>• Check the values set for the motor protection (L1-01, L1-02) as well as the motor rated current (E2-01).</li> <li>• Increase motor capacity.</li> </ul>
The air around the motor is too hot.	<ul style="list-style-type: none"> <li>• Check the ambient temperature.</li> <li>• Cool the area until it is within the specified temperature range.</li> </ul>
Insufficient voltage insulation between motor phases.	<p>When the motor cable is long, high voltage surges occur between the motor coils and drive switching. Normally, surges can reach up to three times the drive input power supply voltage.</p> <ul style="list-style-type: none"> <li>• Use a motor with a voltage tolerance higher than the max voltage surge.</li> <li>• Use an inverter-duty motor rated for use with AC drives when using the motor on drives rated higher than 208 V.</li> <li>• Install an AC reactor on the output side of the drive. The carrier frequency should be set to 2 kHz when installing an AC reactor.</li> </ul>
The motor fan has stopped or is clogged.	Check the motor fan.
The carrier frequency is too low.	Increase the carrier frequency to lower the current harmonic distortion and lower the motor temperature.

## 6.9 Troubleshooting without Fault Display

### ◆ oPE02 Error Occurs When Lowering the Motor Rated Current Setting

Cause	Possible Solutions
Motor rated current and the motor no-load current setting in the drive are incorrect.	<ul style="list-style-type: none"> <li>The user is trying to set the motor rated current in E2-01 to a value lower than the no-load current set in E2-03.</li> <li>Make sure that value set in E2-01 is higher than E2-03.</li> <li>If it is necessary to set E2-01 lower than E2-03, first lower the value set to E2-03, then change the setting in E2-01 as needed.</li> </ul>

### ◆ Motor Stalls during Acceleration or Acceleration Time is Too Long

Cause	Possible Solutions
Current suppression prevents the drive from accelerating.	Take the following steps to resolve the problem: <ul style="list-style-type: none"> <li>Reduce the load.</li> <li>Increase motor capacity.</li> </ul>
Load is too heavy.	<p><b>Note:</b> Although the drive has a Stall Prevention function and a Torque Compensation function, accelerating too quickly or trying to drive an excessively large load can exceed the capabilities of the motor.</p>
Frequency reference is too low.	<ul style="list-style-type: none"> <li>Set E1-03 to a pattern with a higher input frequency.</li> <li>Check U1-01 for proper frequency reference.</li> <li>Check if a frequency reference signal switch has been set to one of the multi-function input terminals.</li> <li>Check for low gain level set to terminals A1 or A2 (H3-03 or H3-11).</li> </ul>
Load is too heavy.	<ul style="list-style-type: none"> <li>Reduce the load so that the output current remains within the motor rated current.</li> <li>Increase the acceleration time.</li> <li>Check if the mechanical brake is fully releasing as it should.</li> </ul>
Acceleration time has been set too long.	Check if the acceleration time parameters have been set too long (C1-01).
Motor characteristics and drive parameter settings are incompatible with one another.	<ul style="list-style-type: none"> <li>Set the correct V/f pattern so that it matches the characteristics of the motor being used.</li> <li>Check the V/f pattern set to E1-03.</li> </ul>
Incorrect frequency reference setting.	<ul style="list-style-type: none"> <li>Check the multi-function analog input settings. Multi-function analog input terminals A1 or A2 are set for frequency gain (H3-02 or H3-10 are set to 1), but there is no voltage or current input provided.</li> <li>Make sure H3-02 and H3-10 are set to the proper values.</li> <li>See if the analog input value is set to the right value (U1-13 and U1-14).</li> </ul>
The Stall Prevention level during acceleration and deceleration set too low.	<ul style="list-style-type: none"> <li>Check the Stall Prevention level during acceleration (L3-02).</li> <li>If L3-02 is set too low, acceleration may be taking too long.</li> <li>Increase L3-02.</li> </ul>
The Stall Prevention level during run has been set too low.	<ul style="list-style-type: none"> <li>Check the Stall Prevention level during run (L3-06).</li> <li>If L3-06 is set too low, speed will drop as the drive outputs torque.</li> <li>Increase the setting value.</li> </ul>
Drive reached the limitations of the V/f motor control method.	<ul style="list-style-type: none"> <li>The motor cable may be long enough (over 50 m) to require Auto-Tuning for line-to-line resistance.</li> <li>Be aware that V/f Control is comparatively limited when it comes to producing torque at low speeds.</li> </ul>

### ◆ Drive Frequency Reference Differs from the Controller Frequency Reference Command

Cause	Possible Solutions
The analog input gain and bias for the frequency reference input are set to incorrect values.	<ul style="list-style-type: none"> <li>Check the gain and bias settings for the analog inputs that are used to set the frequency reference. Check parameters H3-03 and H3-04 for input A1 and check parameters H3-11 and H3-12 for input A2.</li> <li>Set these parameters to the appropriate values.</li> </ul>
A frequency bias signal is being entered via analog input terminals A1 to A2.	<ul style="list-style-type: none"> <li>If multi-function analog inputs A1 and A2 are set for frequency reference bias (H3-02 or H3-10 is set to 0), then the sum of all signals builds the frequency reference.</li> <li>Make sure that H3-02 and H3-10 are set appropriately.</li> <li>Check the input level set for terminals A1 and A2 (U1-13 and U1-14).</li> </ul>

Cause	Possible Solutions
PI control is enabled, and the drive is consequently adjusting the output frequency to match the PI setpoint. The drive will only accelerate to the maximum output frequency set in E1-04 while PI control is active.	If PI control is not necessary for the application, disable it by setting b5-01 to 0.

◆ **Excessive Motor Oscillation and Erratic Rotation**

Cause	Possible Solutions
Poor balance between motor phases.	Check drive input power voltage to ensure that it provides stable power.
Hunting prevention function is disabled.	Set n1-01 to 1 to enable Hunting Prevention.

◆ **Deceleration Takes Longer Than Expected**

Cause	Possible Solutions
L3-04 is set incorrectly.	Check the Stall Prevention level during deceleration (L3-04).
The deceleration time is set too long.	Set deceleration to more appropriate time (C1-02).
Insufficient motor torque.	<ul style="list-style-type: none"> <li>Assuming parameter settings are normal and that no overvoltage occurs when there is insufficient torque, it is likely that the demand on the motor has exceeded the motor capacity.</li> <li>Use a larger motor.</li> </ul>
Load exceeded the internal torque limit determined by the drive rated current.	Switch to a larger capacity drive.

◆ **Noise From Drive or Motor Cables When the Drive is Powered On**

Cause	Possible Solutions
Relay switching in the drive generates excessive noise.	<ul style="list-style-type: none"> <li>Lower the carrier frequency (C6-02).</li> <li>Install a noise filter on the input side of drive input power.</li> <li>Install a noise filter on the output side of the drive.</li> <li>Place the wiring inside a metal conduit to shield it from switching noise.</li> <li>Ground the drive and motor properly.</li> <li>Separate the main circuit wiring and the control lines.</li> <li>Make sure wires and the motor have been properly grounded.</li> </ul>

◆ **Ground Fault Circuit Interrupter (GFCI) Trips During Run**

Cause	Possible Solutions
Excessive leakage current trips GFCI.	<ul style="list-style-type: none"> <li>Check the wiring and rating of peripheral devices.</li> <li>Increase the GFCI sensitivity or use GFCI with a higher threshold.</li> <li>Lower the carrier frequency (C6-02).</li> <li>Reduce the length of the cable used between the drive and the motor.</li> <li>Disable the internal EMC filter.</li> </ul>

◆ **Connected Machinery Vibrates When Motor Rotates**

■ **Unexpected Noise from Connected Machinery**

Cause	Possible Solutions
The carrier frequency is at the resonant frequency of the connected machinery.	Adjust the carrier frequency using parameters C6-02 through C6-05.
The drive output frequency is the same as the resonant frequency of the connected machinery.	<ul style="list-style-type: none"> <li>Adjust the parameters used for the Jump frequency function (d3-01 through d3-04) to skip the problem-causing bandwidth.</li> <li>Place the motor on a rubber pad to reduce vibration.</li> </ul>

**Note:** The drive may have trouble assessing the status of the load due to white noise generated from using Swing PWM (C6-02 = 7 to A).

## 6.9 Troubleshooting without Fault Display

### ■ Oscillation or Hunting

Cause	Possible Solutions
Gain is too low when using PI control.	<i>Refer to b5: PI Control on page 128</i> for details.
The frequency reference is assigned to an external source and the signal is noisy.	<ul style="list-style-type: none"> <li>• Ensure that noise is not affecting the signal lines.</li> <li>• Separate main circuit wiring and control circuit wiring.</li> <li>• Use twisted-pair cables or shielded wiring for the control circuit.</li> <li>• Increase the analog input time filter constant (H3-13).</li> </ul>
The cable between the drive and motor is too long.	<ul style="list-style-type: none"> <li>• Perform Auto-Tuning for line-to-line resistance.</li> <li>• Reduce the length of the cable.</li> </ul>

### ◆ PI Output Fault

Cause	Possible Solutions
No PI feedback input.	<ul style="list-style-type: none"> <li>• Check the multi-function analog input terminal settings.</li> <li>• Set multi-function analog input terminal A1 or, A2 for PI feedback (H3-02 or H3-10 = B).</li> <li>• A signal input to the terminal selection for PI feedback is needed.</li> <li>• Check the connection of the feedback signal.</li> <li>• Check the various PI-related parameter settings.</li> <li>• No PI feedback input to the terminal causes the value detected to be 0, causing a PI fault and the drive to operate at max frequency.</li> </ul>
The level of detection and the target value do not correspond with each other.	<ul style="list-style-type: none"> <li>• PI control keeps the difference between target and detection values at 0. Set the input level for the values relative to one another.</li> <li>• Use analog input gains H3-03 and H3-11 to adjust PI target and feedback signal scaling.</li> </ul>
Reverse drive output frequency and speed detection. When output frequency rises, the sensor detects a speed decrease.	Set PI output for reverse characteristics (b5-09 = 1).
PI parameter setting adjustments are insufficient.	<i>Refer to b5: PI Control on page 128</i> for details.

### ◆ Motor Rotates after the Drive Output is Shut Off (Motor Rotates During DC Injection Braking)

Cause	Possible Solutions
DC Injection Braking is set too low and the drive cannot decelerate properly.	<ul style="list-style-type: none"> <li>• Adjust the DC Injection braking settings.</li> <li>• Increase the current level for DC Injection Braking Current (b2-02).</li> <li>• Increase the DC Injection Braking time at stop (b2-04).</li> </ul>
The stopping method is set so that the drive coasts to stop.	Set b1-03 (Stopping Method Selection) to 0 or 2.

### ◆ Output Frequency is Not as High as Frequency Reference

Cause	Possible Solutions
Frequency reference is set within the range of the Jump frequency.	<ul style="list-style-type: none"> <li>• Adjust the parameters used for the Jump frequency function (d3-01, d3-02, d3-03).</li> <li>• Enabling the Jump frequency prevents the drive from outputting the frequencies specified in the Jump range.</li> </ul>
Large load triggered Stall Prevention function during acceleration.	<ul style="list-style-type: none"> <li>• Reduce the load.</li> <li>• Adjust the Stall Prevention level during acceleration (L3-02).</li> </ul>

### ◆ Sound from Motor

Cause	Possible Solutions
Exceeded 110% of the rated output current of the drive while operating at low speeds.	<ul style="list-style-type: none"> <li>• If the output current rises too high at low speeds, the carrier frequency is automatically reduced and causes a whining or buzzing sound.</li> <li>• If the sound is coming from the motor, disable carrier frequency derating (L8-38 = 0).</li> <li>• Disabling the automatic carrier frequency derating increases the chances of an overload fault (oL2). Switch to a larger capacity motor if oL2 faults occur too frequently.</li> </ul>



**◆ Motor Does Not Restart after Power Loss**

Cause	Possible Solutions
The Run command was not issued again when power was restored.	<ul style="list-style-type: none"><li>• Check the sequence and wiring that has been set up to enter the Run command.</li><li>• A relay should be set up to make sure the Run command remains enabled throughout any power loss.</li></ul>
The relay that is supposed to maintain the Run command has been switched off.	Check wiring and circuitry for the relay intended to keep the Run command enabled.

**This Page Intentionally Blank**

## Peripheral Devices & Options

---

7.1	SECTION SAFETY.....	268
7.2	BYPASS COMMUNICATION OPTIONS.....	270
7.3	OPTION INSTALLATION PROCEDURE.....	271

## 7.1 Section Safety

### DANGER

#### Electrical Shock Hazard

**Do not connect or disconnect wiring while the power is on.**

Failure to comply will result in death or serious injury.

Disconnect all power to the bypass and wait at least the amount of time specified on the bypass front cover safety label. After all indicators are off, measure the DC bus voltage to confirm safe level, and check for unsafe voltages before servicing. The internal capacitor remains charged after the power supply is turned off.

### WARNING

#### Electrical Shock Hazard

Failure to comply could result in death or serious injury.

The diagrams in this section may include options and bypass units without covers or safety shields to show details. Be sure to reinstall covers or shields before operating any devices. The option should be used according to the instructions described in this manual.

**Do not allow unqualified personnel to use equipment.**

Failure to comply could result in death or serious injury.

Maintenance, inspection, and replacement of parts must be performed only by authorized personnel familiar with installation, adjustment, and maintenance of this product.

Failure to comply could result in death or serious injury.

**Do not use damaged wires, stress the wiring, or damage the wire insulation.**

Failure to comply could result in death or serious injury.

**Do not use damaged wires, place excessive stress on wiring, or damage the wire insulation.**

Failure to comply could result in death or serious injury.

#### Fire Hazard

**Tighten all terminal screws to the specified tightening torque.**

Loose electrical connections could result in death or serious injury by fire due to overheating of electrical connections.

### NOTICE

**Observe proper electrostatic discharge procedures (ESD) when handling the bypass and circuit boards.**

Failure to comply may result in ESD damage to the bypass circuitry.

**Never shut the power off while the bypass is outputting voltage.**

Failure to comply may cause the application to operate incorrectly or damage the bypass.

**Do not operate damaged equipment.**

Failure to comply may cause further damage to the equipment.

Do not connect or operate any equipment with visible damage or missing parts.

**Do not use unshielded cable for control wiring.**

Failure to comply may cause electrical interference resulting in poor system performance.

Use shielded twisted-pair wires and ground the shield to the ground terminal of the bypass.

**NOTICE**

**Properly connect all pins and connectors.**

Failure to comply may prevent proper operation and possibly damage equipment.

**Check wiring to ensure that all connections are correct after installing the option and connecting any other devices.**

Failure to comply could result in damage to the option.

# 7.2 Bypass Communication Options

**Table 7.1** lists communication options available for the bypass. Contact Yaskawa or your Yaskawa agent to order these options.

**Table 7.1 Available Communication Options**

Option Protocol	Option Model Number	Option Technical Manual	Description	Supported Bypass Software Version
EtherNet/IP	SI-EN3, SI-EN3D	SIEPYAICOM22	Connects to an EtherNet/IP network.	VST800298 and later
LonWorks	SI-W3	SIEPYAICOM26	Connects to a LonWorks network.	
Modbus TCP/IP	SI-EM3, SI-EM3D	SIEPYAICOM23	Connects to a Modbus TCP/IP network.	
PROFINET	SI-EP3	SIEPYAICOM25	Connects to a PROFINET network.	

### ◆ Tools Required for Option Installation

- A Phillips screwdriver (M3 metric or #1, #2 U.S. standard) is required to install the option and remove the bypass front cover. Screw sizes vary by capacity. Select a screwdriver appropriate for the capacity.
- Use a short-shaft, magnetic screwdriver when installing the option card into the narrow enclosure models Z1B1D002 to Z1B1D074 and Z1B1B001 to Z1B1B077.
- A straight-edge screwdriver (blade depth: 0.4 mm, width: 2.5 mm) is required to wire the option terminal block when installing the SI-W3 LonWorks option.

**Note:** Tools required to prepare the option cables for wiring are not listed in this manual.

## 7.3 Option Installation Procedure

This section explains how to properly mount and install a communication option card to the bypass.

### ◆ Prior to Installing the Option

**NOTICE:** Install communications options on the bypass control PCB. Do not install communications options on the drive PCB. Improperly connected communications options will cause erroneous operation.

### ■ Verify Bypass Operation

Verify that the bypass functions normally without the option installed. Refer to [Electrical Installation](#) on 49 for information on wiring and connecting the bypass unit.

### ■ Prepare Network Cables for SI-W3 LonWorks Option

Use only the LonWorks network cables.

Refer to the Echelon web site for more information on network cabling ([www.echelon.com](http://www.echelon.com)). The performance cannot be guaranteed when using the cables other than LonWorks network cables.

Separate the LonWorks cables from the wiring to the main circuit and other lines.

Determine the length of cable required to connect from the option to a network device and attach all connectors to network cables before installing the option.

The communication terminal is a pluggable terminal block that serves as the connection point of the LonWorks network cable to the option.

Table 7.2 Terminal CN1 Descriptions

Terminal	Terminal No.	Name	Description
1	1	A	Signal Line A
2	2	SLD	Shield
3	3	B	Signal Line B

**NOTICE:** Heat shrink tubing or electrical tape may be required to ensure that cable shielding does not come into contact with other wiring. Insufficient insulation may cause a short circuit that can damage the option or the bypass.

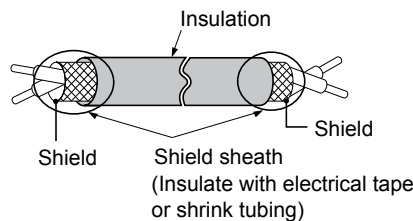
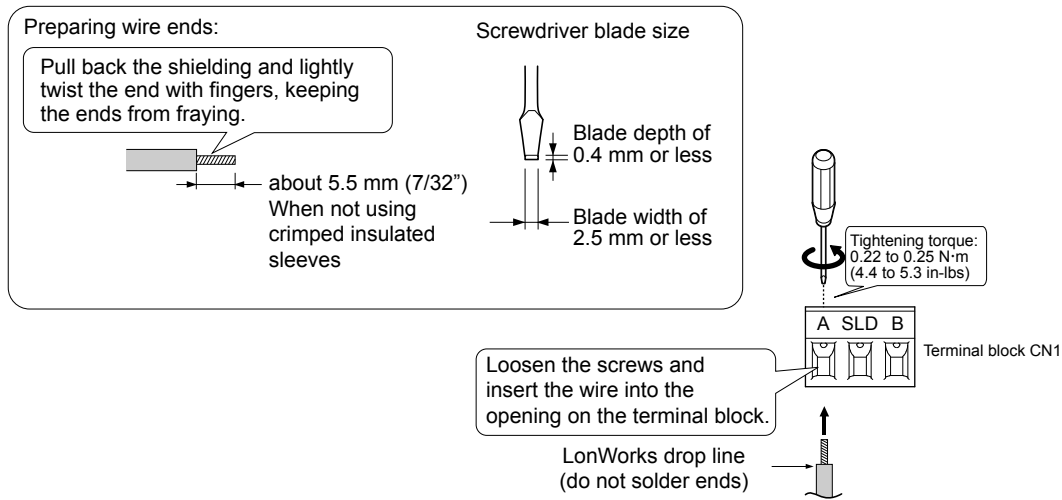

Figure 7.1 Preparing Ends of Shielded Cable

**Note:** Separate network cables from main circuit wiring and other electrical lines.

## 7.3 Option Installation Procedure



**Figure 7.2 Preparing and Connecting Network Cable Wiring**

### ■ Prepare Network Cables for Non-LonWorks Options

Determine the length of cable required to connect from the option to a network device and attach all connectors to network cables before installing the option. Refer to [Table 7.4 Network Cable Specifications](#) for details.

The network connection point on the option is designated CN1. CN1 may have 2 ports depending on the option type.

CN1 is the connection point for a customer-supplied network cable with a modular RJ45 connector.

**Table 7.3 8-Way Modular Connector (Customer-Supplied)**

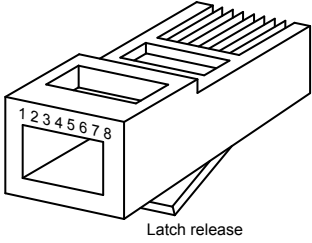
Male 8-Way Modular Connector	Pin	Description
	1 (Pair 2)	Transmit data (TXD) +
	2 (Pair 2)	Transmit data (TXD) -
	3 (Pair 3)	Receive data (RXD) +
	4 (Pair 1)	Not used <1>
	5 (Pair 1)	Not used <1>
	6 (Pair 3)	Receive data (RXD) -
	7 (Pair 4)	Not used <1>
	8 (Pair 4)	Not used <1>

<1> Not used for 10 Mbps and 100 Mbps networks.

**Table 7.4 Network Cable Specifications**

Communication Protocol	Description
EtherNet/IP	Only use cable recommended for EtherNet/Industrial Protocol (EtherNet/IP™). Using a cable not specifically recommended may cause the option or bypass to malfunction. Refer to the ODVA website for more information on network cabling ( <a href="http://www.odva.org">www.odva.org</a> ).
Modbus TCP/IP	Only use cable recommended for Modbus TCP/IP. Using a cable not specifically recommended may cause the option or bypass to malfunction. Refer to the Modbus-IDA website for more information on network cabling ( <a href="http://www.modbus.org">www.modbus.org</a> ).
PROFINET	Only use cable recommended for PROFINET. Using a cable not specifically recommended may cause the option or bypass to malfunction. Refer to the PROFIBUS and PROFINET International (PI) website for more information ( <a href="http://www.profibus.com">www.profibus.com</a> ).



## ◆ Remove the Bypass Front Cover

**WARNING!** *Electrical Shock Hazard. Do not open the front cover of the bypass while the power is on. Failure to comply may result in death or serious injury. Make sure that the disconnect handle is in the “OFF” position before attempting to open the front cover.*

### ■ Models Z1B1D002 to D074 and Z1B1B001 to B077

1. Turn the disconnect handle to the “OFF” position and wait the appropriate amount of time for voltage to dissipate. Verify using a multimeter and follow all appropriate lockout/tagout procedures.

**NOTICE:** *Damage to Equipment. Observe proper electrostatic discharge procedures (ESD) when handling the option, bypass, and circuit boards. Failure to comply may result in ESD damage to circuitry.*

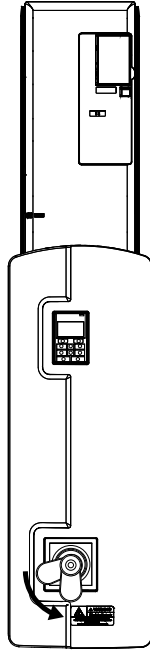

Figure 7.3 Disconnect Power

## 7.3 Option Installation Procedure

2. Remove the two front cover screws using a #2 Phillips screwdriver.

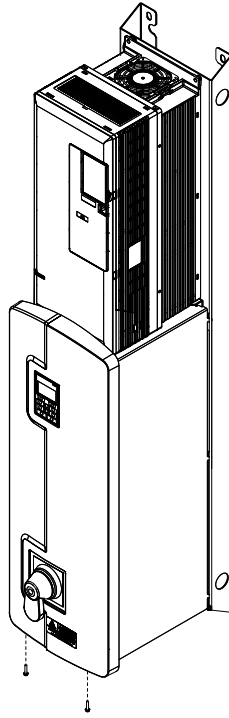

Figure 7.4 Remove Front Cover Screws

3. Lift the cover up and gently pull forward to remove the front cover.

**NOTICE:** Do not damage the Cat5e cable that connects the keypad to the bypass control PCB when removing the front cover. Failure to comply may cause erroneous operation.

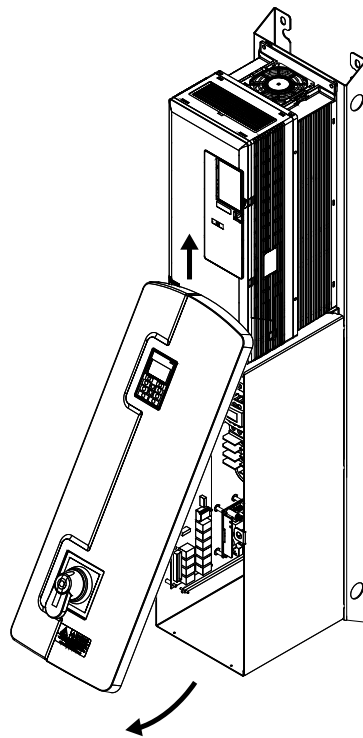

Figure 7.5 Lift and Remove Front Cover

### ■ Models Z1B1D088 to D273 and Z1B1B096 to B302

1. Turn the disconnect handle to the “OFF” position and wait the appropriate amount of time for voltage to dissipate. Verify using a multimeter and follow all appropriate lockout/tagout procedures.

**NOTICE:** *Damage to Equipment. Observe proper electrostatic discharge procedures (ESD) when handling the option, bypass, and circuit boards. Failure to comply may result in ESD damage to circuitry.*

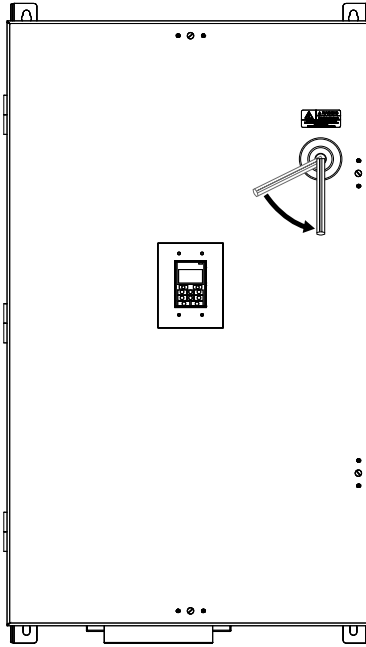

Figure 7.6 Disconnect Power

2. Turn the flat head screw fasteners on the front cover 1/2 turn counter-clockwise.

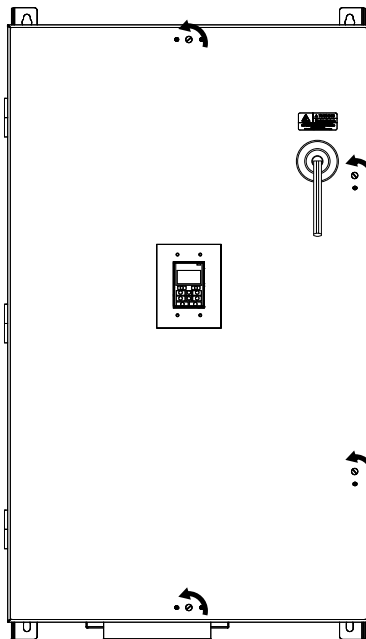

Figure 7.7 Turn Front Cover Fasteners

### 7.3 Option Installation Procedure

---

3. Carefully swing open the bypass front cover door.

**NOTICE:** Do not damage the Cat5e cable that connects the keypad to the bypass control PCB when removing the front cover. Failure to comply may cause erroneous operation.

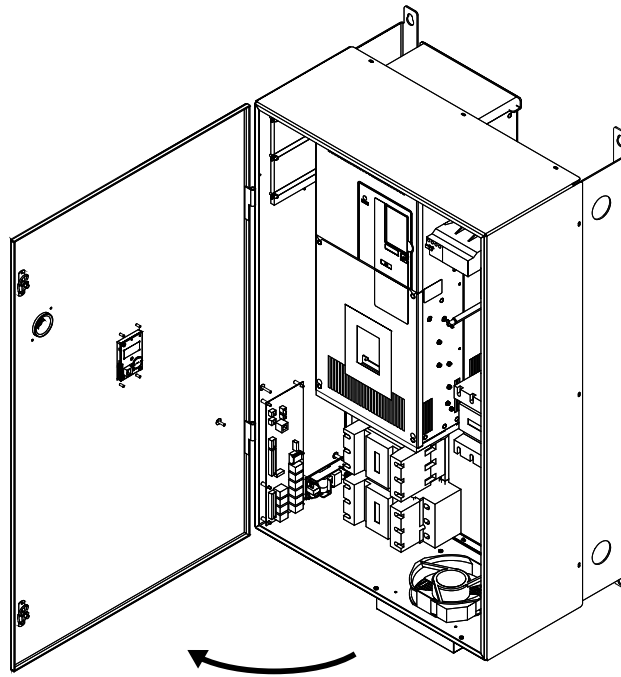

Figure 7.8 Swing Open Door

## ◆ Install the Option

**DANGER! Electrical Shock Hazard.** Do not connect or disconnect wiring while the power is on. Failure to comply could result in death or serious injury. Before installing the option, disconnect all power to the bypass and wait at least the amount of time specified on the bypass front cover safety label. After all indicators are off, measure the DC bus voltage to confirm safe level, and check for unsafe voltages before servicing. The internal capacitor remains charged after the power supply is turned off.

1. Fasten the option card to the metal standoffs on the bypass PCB using two screws included in the option kit. Use a short-shaft, magnetic screwdriver for narrow enclosure models Z1B1D002 to Z1B1D074 and Z1B1B001 to Z1B1B077. Tighten each screw to 0.5 to 0.6 N•m (4.4 to 5.3 in lbs).

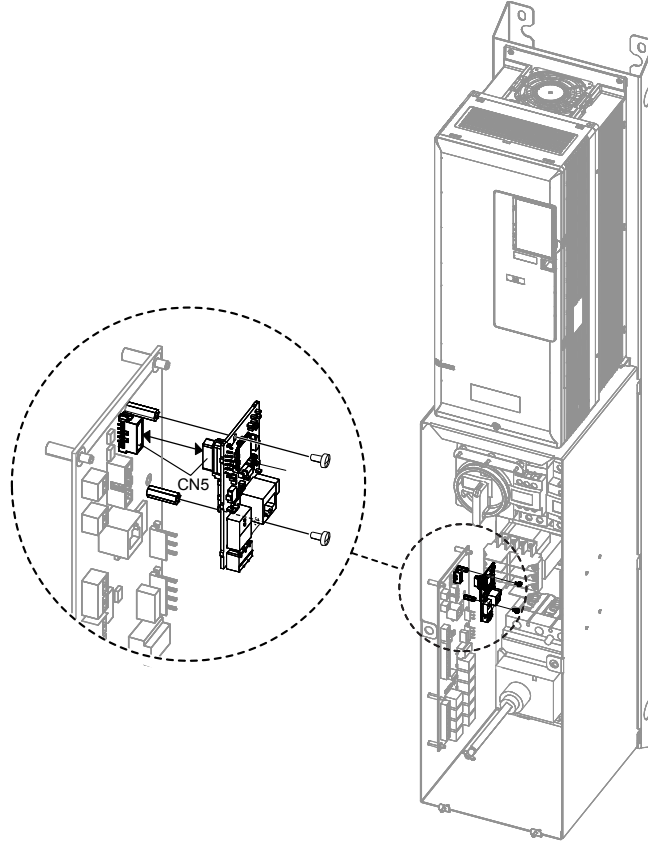

Figure 7.9 Insert Option into Bypass PCB CN5 Connector Port - Model Z1B1D002

## 7.3 Option Installation Procedure

2. Connect the customer-supplied network cable to the option by firmly inserting the end of the cable into the CN1 connection port on the option board.  
When using a dual-port option, connect two network cables to the two network ports in CN1 for flexibility in cabling topology.

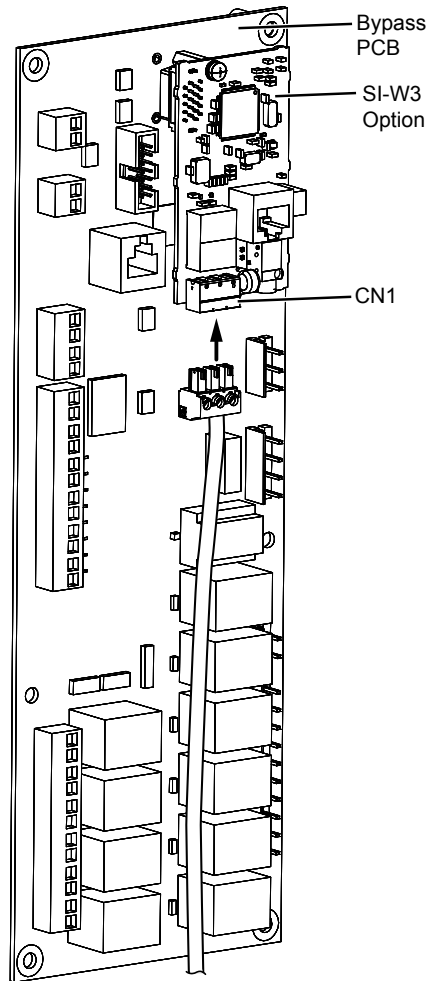

Figure 7.10 Connect Network Cable to Option (SI-W3 LonWorks Example)

**NOTICE:** Separate control circuit wiring from main circuit wiring and other high-power lines. Improper wiring practices could result in bypass malfunction due to electrical interference.

Connection Diagram - SI-W3 LonWorks Option

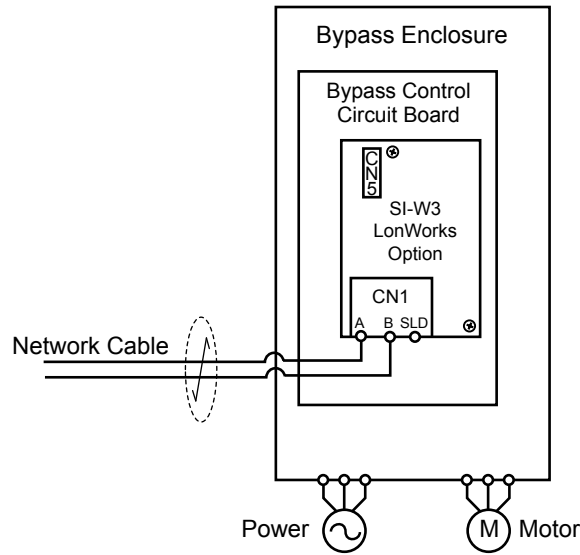

Figure 7.11 Option Connection Diagram

Connection Diagram - Non-LonWorks Options

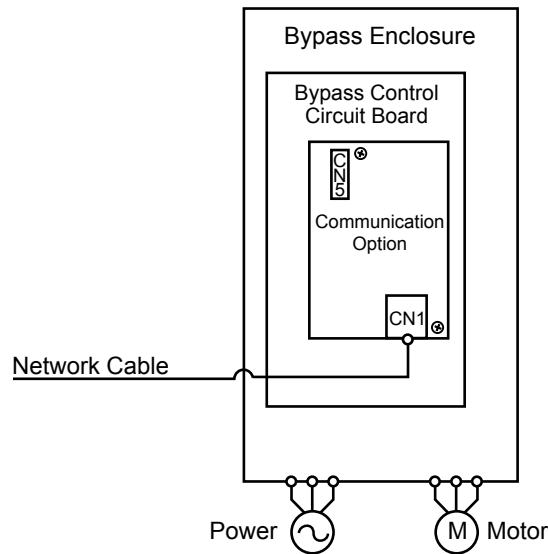
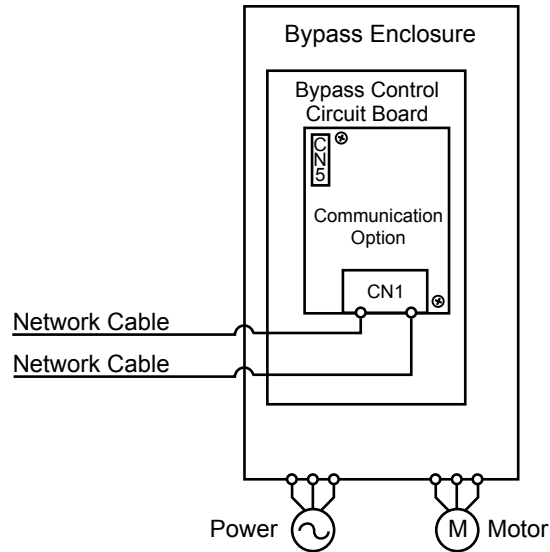

Figure 7.12 Option Connection Diagram (Single Port CN1 Connection)



**Figure 7.13 Option Connection Diagram (Dual-Port CN1 Connection)**

3. Make sure no cables are pinched between the front cover and the bypass enclosure, then replace and secure the front cover.
4. Set bypass parameters for option functionality.

Refer to the option technical manual for your communication protocol for programming information. Refer to **Option Programming and Troubleshooting** for details.

### ◆ Option Programming and Troubleshooting

For additional programming and troubleshooting information, download the correct option technical manual for your communication protocol from [www.yaskawa.com](http://www.yaskawa.com). Refer to [Table 7.5](#) to find the manual document number.

**Table 7.5 Communication Option Technical Manuals**

Option Protocol	Option Model Number	Document Number
EtherNet/IP	SI-EN3, SI-EN3D	SIEPYAICOM22
LonWorks	SI-W3	SIEPYAICOM26
Modbus TCP/IP	SI-EM3, SI-EM3D	SIEPYAICOM23
PROFINET	SI-EP3	SIEPYAICOM25



# Periodic Inspection & Maintenance

---

This chapter describes the periodic inspection and maintenance of the Z1000 Bypass to ensure that it receives the proper care to maintain overall performance.

<b>8.1</b>	<b>SECTION SAFETY.....</b>	<b>282</b>
<b>8.2</b>	<b>INSPECTION.....</b>	<b>284</b>
<b>8.3</b>	<b>PERIODIC MAINTENANCE.....</b>	<b>287</b>
<b>8.4</b>	<b>HOA KEYPAD BATTERY REPLACEMENT.....</b>	<b>289</b>
<b>8.5</b>	<b>DRIVE COOLING FANS.....</b>	<b>291</b>

## 8.1 Section Safety

### WARNING

#### Electrical Shock Hazard

**Do not connect or disconnect wiring while the power is on.**

Failure to comply could result in death or serious injury.

Before servicing, disconnect all power to the equipment. The internal capacitor remains charged even after the power supply is turned off. The charge indicator LED will extinguish when the DC bus voltage is below 50 Vdc. To prevent electric shock, wait for at least the time specified on the warning label; after all indicators are OFF, measure for unsafe voltages to confirm the drive is safe prior to servicing.

**Do not operate equipment with covers removed.**

Failure to comply could result in death or serious injury.

The diagrams in this section may show drives without covers or safety shields to show details. Be sure to reinstall covers or shields before operating the drives and run the drives according to the instructions described in this manual.

**Always ground the motor-side grounding terminal.**

Improper equipment grounding could result in death or serious injury by contacting the motor case.

**Do not remove covers or touch circuit boards while the power is on.**

Failure to comply could result in death or serious injury.

**Do not allow unqualified personnel to perform work on the drive.**

Failure to comply could result in death or serious injury.

Installation, maintenance, inspection, and servicing must be performed only by authorized personnel familiar with installation, adjustment, and maintenance of AC drives.

**Do not perform work on the drive while wearing loose clothing, jewelry or without eye protection.**

Failure to comply could result in death or serious injury.

Remove all metal objects such as watches and rings, secure loose clothing, and wear eye protection before beginning work on the drive.

**Do not touch any terminals before the capacitors have fully discharged.**

Failure to comply could result in death or serious injury.

Before servicing, disconnect all power to the equipment. The internal capacitor remains charged even after the power supply is turned off. The charge indicator LED will extinguish when the DC bus voltage is below 50 Vdc. To prevent electric shock, wait for at least the time specified on the warning label; after all indicators are OFF, measure the DC bus voltage level to confirm it has reached a safe level.

#### Fire Hazard

**Tighten all terminal screws to the specified tightening torque.**

Loose electrical connections could result in death or serious injury by fire due to overheating of electrical connections.

**Do not use an improper voltage source.**

Failure to comply could result in death or serious injury by fire.

Verify that the rated voltage of the drive matches the voltage of the incoming power supply before applying power.

**Do not use improper combustible materials.**

Failure to comply could result in death or serious injury by fire.

Attach the drive to metal or other noncombustible material.

**NOTICE****Observe proper electrostatic discharge procedures (ESD) when handling the drive and circuit boards.**

Failure to comply may result in ESD damage to the drive circuitry.

**Follow cooling fan replacement instructions. The cooling fan cannot operate properly when it is installed incorrectly and could seriously damage the drive.**

Follow the instructions in this manual to replace the cooling fan, making sure that the label is on top before inserting the cooling fan into the drive. To ensure maximum useful product life, replace both cooling fans when performing maintenance.

**Never connect or disconnect the motor from the drive while the drive is outputting voltage.**

Improper equipment sequencing could result in damage to the drive.

**Do not use unshielded cable for control wiring.**

Failure to comply may cause electrical interference resulting in poor system performance. Use shielded, twisted-pair wires and ground the shield to the ground terminal of the drive.

**Do not allow unqualified personnel to use the product.**

Failure to comply could result in damage to the drive or braking circuit.

Maintenance, inspection, and replacement of parts must be performed only by authorized personnel familiar with installation, adjustment and maintenance of AC drives.

**Do not modify the drive circuitry.**

Failure to comply could result in damage to the drive and will void warranty.

Yaskawa is not responsible for any modification of the product made by the user. This product must not be modified.

**Check all the wiring to ensure that all connections are correct after installing the drive and connecting any other devices.**

Failure to comply could result in damage to the drive.

**Comply with proper wiring practices.**

The motor may run in reverse if the phase order is backward.

Connect motor input terminals U, V and W to drive output terminals U/T1, V/T2, and W/T3. The phase order for the drive and motor should match.

**Frequently switching the drive power supply to stop and start the motor can damage the drive.**

To get the full performance life out of the electrolytic capacitors and circuit relays, refrain from switching the drive power supply off and on more than once every 30 minutes. Frequent use can damage the drive. Use the drive to stop and start the motor.

**Do not operate damaged equipment.**

Failure to comply could result in further damage to the equipment.

Do not connect or operate any equipment with visible damage or missing parts.

## 8.2 Inspection

Power electronics have limited life and may exhibit changes in characteristics or performance deterioration after years of use under normal conditions. To help avoid such problems, it is important to perform preventive maintenance and periodic inspection on the drive.

Drives contain a variety of power electronics such as power transistors, semiconductors, capacitors, resistors, fans, and relays. The electronics in the drive serve a critical role in maintaining proper motor control.

Follow the inspection lists provided in this chapter as a part of a regular maintenance program.

**Note:** The drive will require more frequent inspection if it is placed in harsh environments, such as:

- High ambient temperatures
- Frequent starting and stopping
- Fluctuations in the AC supply or load
- Excessive vibrations or shock loading
- Dust, metal dust, salt, sulfuric acid, chlorine atmospheres
- Poor storage conditions.

Perform the first equipment inspection one to two years after installation.

### ◆ Recommended Daily Inspection

*Table 8.1* outlines the recommended daily inspection for Yaskawa drives. Check the following items on a daily basis to avoid premature deterioration in performance or product failure. Copy this checklist and mark the “Checked” column after each inspection.

**Table 8.1 General Recommended Daily Inspection Checklist**

Inspection Category	Inspection Points	Corrective Action	Checked
<b>Motor</b>	Inspect for abnormal oscillation or noise coming from the motor.	<ul style="list-style-type: none"> <li>• Check the load coupling.</li> <li>• Measure motor vibration.</li> <li>• Tighten all loose components.</li> </ul>	
<b>Cooling</b>	Inspect for abnormal heat generated from the drive or motor and visible discoloration.	Check for the following: <ul style="list-style-type: none"> <li>• Excessive load.</li> <li>• Loose connections.</li> <li>• Dirty heatsink or motor.</li> <li>• Ambient temperature.</li> </ul>	
	Inspect drive cooling fan and circulation fan operation.	Check for the following: <ul style="list-style-type: none"> <li>• Clogged or dirty fan.</li> <li>• Correct Fan operation parameter setting.</li> </ul>	
<b>Environment</b>	Verify the drive environment complies with the specifications listed in the Specifications chapter in the User Manual packaged with the drive.	Eliminate the source of contaminants or correct poor environment.	
<b>Load</b>	The drive output current should not be higher than the motor or drive rating for an extended period of time.	Check for the following: <ul style="list-style-type: none"> <li>• Excessive load.</li> <li>• Correct motor parameter settings.</li> </ul>	
<b>Power Supply Voltage</b>	Check main power supply and control voltages.	<ul style="list-style-type: none"> <li>• Correct the voltage or power supply to within nameplate specifications.</li> <li>• Verify all main circuit phases.</li> </ul>	

## ◆ Recommended Periodic Inspection

**Table 8.2** outlines the recommended periodic inspections for Yaskawa drive installations. Although periodic inspections should generally be performed once a year; the drive may require more frequent inspection in harsh environments or with rigorous use. Operating and environmental conditions, along with experience in each application, will determine the actual inspection frequency for each installation. Periodic inspection will help to avoid premature deterioration in performance or product failure. Copy this checklist and mark the “Checked” column after each inspection.

### ■ Periodic Inspection

**WARNING! Electrical Shock Hazard.** Do not inspect, connect, or disconnect any wiring while the power is on. Failure to comply can result in serious personal injury. Before servicing, disconnect all power to the equipment. The internal capacitor remains charged even after the power supply is turned off. The charge indicator LED will extinguish when the DC bus voltage is below 50 Vdc. To prevent electric shock, wait for at least the time specified on the warning label; after all indicators are OFF, measure for unsafe voltages to confirm the drive is safe prior to servicing.

**Table 8.2 Periodic Inspection Checklist**

Inspection Area	Inspection Points	Corrective Action	Checked
<b>Main Circuit Periodic Inspection</b>			
General	<ul style="list-style-type: none"> <li>Inspect equipment for discoloration from overheating or deterioration.</li> <li>Inspect for damaged or deformed parts.</li> </ul>	<ul style="list-style-type: none"> <li>Replace damaged components as required.</li> <li>The drive has few serviceable parts and may require complete drive replacement.</li> </ul>	
	Inspect for dirt, foreign particles, or dust collection on components.	<ul style="list-style-type: none"> <li>Inspect enclosure door seal if used.</li> <li>Remove foreign particles and dust with a vacuum cleaner to avoid touching parts.</li> <li>Replace components if cleaning is not possible.</li> </ul>	
Conductors and Wiring	<ul style="list-style-type: none"> <li>Inspect wiring and connections for discoloration, damage, or heat stress.</li> <li>Inspect wire insulation and shielding for wear.</li> </ul>	Repair or replace damaged wiring.	
Terminals	Inspect terminals for stripped, damaged, or loose connections.	Tighten loose screws and replace damaged screws or terminals.	
Relays and Contactors	<ul style="list-style-type: none"> <li>Inspect contactors and relays for excessive noise during operation.</li> <li>Inspect coils for signs of overheating such as melted or cracked insulation.</li> </ul>	<ul style="list-style-type: none"> <li>Check coil voltage for overvoltage or undervoltage conditions.</li> <li>Replace damaged removable relays, contactors, or circuit board.</li> </ul>	
Electrolytic Capacitor	<ul style="list-style-type: none"> <li>Inspect for leaking, discoloration, or cracks.</li> <li>Check if the cap has come off, for any swelling, or if the sides have burst open.</li> </ul>	The drive has few serviceable parts and may require complete drive replacement.	
Diode, IGBT (Power Transistor)	Inspect for dust or other foreign material collected on the surface.	Remove foreign particles and dust with a vacuum cleaner to avoid touching parts.	
<b>Motor Periodic Inspection</b>			
Operation Check	Check for increased vibration or abnormal noise.	Stop the motor and contact qualified maintenance personnel as required.	
<b>Control Circuit Periodic Inspection</b>			
General	<ul style="list-style-type: none"> <li>Inspect terminals for stripped, damaged, or loose connections.</li> <li>Make sure all terminals have been properly tightened.</li> </ul>	<ul style="list-style-type: none"> <li>Tighten loose screws and replace damaged screws or terminals.</li> <li>If terminals are integral to a circuit board, then board or drive replacement may be required.</li> </ul>	
Circuit Boards	Check for any odor, discoloration, and rust. Make sure connections are properly fastened and that no dust or oil mist has accumulated on the surface of the board.	<ul style="list-style-type: none"> <li>Fix any loose connections.</li> <li>If an antistatic cloth or vacuum plunger cannot be used, replace the board.</li> <li>Do not use any solvents to clean the board.</li> <li>Remove foreign particles and dust with a vacuum cleaner to avoid touching parts.</li> </ul> <p>The drive has few serviceable parts and may require complete drive replacement.</p>	
<b>Cooling System Periodic Inspection</b>			
Cooling Fan, Circulation Fan, Control Board Cooling Fan	<ul style="list-style-type: none"> <li>Check for abnormal oscillation or unusual noise.</li> <li>Check for damaged or missing fan blades.</li> </ul>	<ul style="list-style-type: none"> <li>Replace as required.</li> <li><b>Refer to Drive Cooling Fans on page 291</b> for information on cleaning or replacing the fan.</li> </ul>	
Heatsink	Inspect for dust or other foreign material collected on the surface.	Remove foreign particles and dust with a vacuum cleaner to avoid touching parts.	

## 8.2 Inspection

Inspection Area	Inspection Points	Corrective Action	Checked
Air Duct	Inspect air intake and exhaust openings. They must be free from obstruction and properly installed.	<ul style="list-style-type: none"><li>• Visually inspect the area.</li><li>• Clear obstructions and clean air duct as required.</li></ul>	
<b>Display Periodic Inspection</b>			
HOA Keypad	<ul style="list-style-type: none"><li>• Make sure data appears on the display properly.</li><li>• Inspect for dust or other foreign material that may have collected on surrounding components.</li></ul>	<ul style="list-style-type: none"><li>• Contact the nearest sales office if there is any trouble with the display or keypad.</li><li>• Clean the HOA keypad.</li></ul>	

## 8.3 Periodic Maintenance

The drive has Maintenance Monitors that keep track of component wear. This feature provides advance maintenance warning and eliminates the need to shut down the entire system for unexpected problems. The drive allows the user to check predicted maintenance periods for the components listed below.

- Cooling Fan, Circulation Fan, Control Board Cooling Fan
- Electrolytic Capacitors
- Inrush Prevention Circuit
- IGBTs

For replacement parts, contact the distributor where the drive was purchased or contact Yaskawa directly.

### ◆ Replacement Parts

**Table 8.3** contains the estimated performance life of components that require replacement during the life of the drive. Only use Yaskawa replacement parts for the appropriate drive model and revision.

**Table 8.3 Estimated Performance Life**

Component	Estimated Performance Life
Cooling Fan, Circulation Fan	5 years
Electrolytic Capacitors	5 years </>

<1> The drive has few serviceable parts and may require complete drive replacement.

**NOTICE:** *Estimated performance life based on specific usage conditions. These conditions are provided for the purpose of replacing parts to maintain performance. Some parts may require more frequent replacement due to poor environments or rigorous use.*

*Usage conditions for estimated performance life:*

*Ambient temperature: Yearly average of 30 °C (IP20/NEMA 1, UL Type 1 enclosure, external heatsink) or 40 °C (IP00/Open-Type enclosure)*

*Load factor: 80% maximum*

*Operation time: 24 hours a day*

### ■ Performance Life Monitors Maintenance Monitors

The drive calculates the maintenance period for components that may require replacement during the life of the drive. A percentage of the maintenance period is displayed on the HOA keypad by viewing the appropriate monitor parameter.

When the maintenance period reaches 100%, there is increased risk that the drive may malfunction. Yaskawa recommends checking the maintenance period regularly to ensure maximum performance life.

**Refer to Recommended Periodic Inspection on page 285** for more details.

**Table 8.4 Performance Life Monitors Used for Component Replacement**

Parameter	Component	Contents
U4-03	Cooling Fan Circulation Fan	Displays the accumulated operation time of the fan, from 0 to 99999 hours. This value is automatically reset to 0 once it reaches 99999.
U4-04	Control Board Cooling Fan	Displays the accumulated fan operation time as a percentage of the specified maintenance period.
U4-05	DC Bus Capacitors	Displays the accumulated time the capacitors are used as a percentage of the specified maintenance period.
U4-06	Inrush (pre-charge) Relay	Displays the number of times the drive is powered up as a percentage of the performance life of the inrush circuit.

## 8.3 Periodic Maintenance

### ■ Alarm Outputs for Maintenance Monitors

An output can be set up to inform the user when a specific components has neared its expected performance life.

When one of multi-function digital output terminals has been assigned the maintenance monitor function (H2-□□ = 2F<1>), the terminal will close when the cooling fan, DC bus capacitors, or DC bus pre-charge relay reach 90% of the expected performance life, or when the IGBTs have reached 50% of their expected performance life. Additionally the HOA keypad will display an alarm like shown in **Table 8.5** to indicate the specific components that may need maintenance.

<1> Details on this function can be found in the standard Z1000 Programming Manual (SIEPC71061645) at [www.yaskawa.com](http://www.yaskawa.com).

**Table 8.5 Maintenance Alarms**

HOA Keypad Alarm Display		Function	Corrective Action
<i>LF-1</i>	LT-1	The cooling fans have reached 90% of their designated life time.	Replace the cooling fan.
<i>LF-2</i>	LT-2	The DC bus capacitors have reached 90% of their designated life time.	Contact a Yaskawa representative or the nearest Yaskawa sales office on possible drive replacement.
<i>LF-3</i>	LT-3	The DC bus charge circuit has reached 90% of its designated life time.	Contact a Yaskawa representative or the nearest Yaskawa sales office on possible drive replacement.



## 8.4 HOA Keypad Battery Replacement

The HOA keypad contains a monitor battery that allows the user to check drive functions. The battery requires periodic replacement because the lifespan of the battery is shorter than the performance life of the HOA keypad.

**WARNING! Fire Hazard.** Properly handle the HOA keypad battery. Improper use of the battery may cause fire by explosion and injury. Correctly install the battery, paying attention to polarity (+/-). Do not charge the battery or improperly disassemble the HOA keypad.

When replacing the battery, use a Hitachi Maxell CR1220 Lithium Manganese Dioxide Battery or an equivalent battery with the following specifications:

- Nominal Voltage 3 V
- Operating Temperature Range -20 °C to +85 °C
- Nominal battery life of 2 years (ambient temperature of +20 °C).

**NOTICE:** Do not heat or throw the battery into fire. The battery remains in use even when power to the drive has been shut off. Be sure to also remove the battery in the HOA keypad when the drive will be shut off for long periods of time.

A dead battery left inside the HOA keypad may leak and damage the keypad and drive. Replace the battery with a new one immediately after the expected lifespan has passed or when the “bAT” error is displayed on the HOA keypad.

**NOTICE:** Observe Perchlorate Best Management Practices (BMPs). BMPs apply to primary lithium (manganese dioxide) coin batteries sold or distributed in California. Perchlorate Material special handling may apply, please refer to: [www.dtsc.ca.gov/hazardouswaste/perchlorate](http://www.dtsc.ca.gov/hazardouswaste/perchlorate).

### ◆ Real-Time Clock Adjustment

The HOA keypad will display the Real Time Clock Adjustment Display as shown in [Figure 8.1](#) where the user can adjust the Real-Time Clock. [Refer to Manual Clock Adjustment Procedure on page 290](#) for the Real-Time Clock setting procedure.

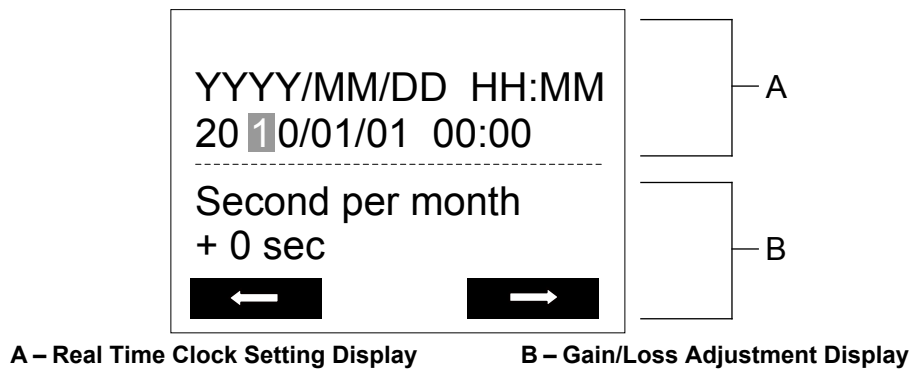

Figure 8.1 Real Time Clock Adjustment Display

Display	Description
YYYY	Set the year with the last two digits.
MM	Set the month with two digits.
DD	Set the day with two digits.
HH:MM	Set the hours and minutes, with two digits for each.
Second per month	Set the gain or loss in seconds per month.

#### Moving the Cursor

Pressing the F2 key or the RESET key will move the cursor to the digit on the right. Pressing the F1 key will move the cursor to the left.

#### Changing Settings

- **Changing YYYY/MM/DD HH:MM:** Pressing the up arrow key will increase the number selected by the cursor from 0 to 9. Pressing the down arrow key will decrease the number selected by the cursor from 0 to 9.
- **Setting the Seconds per Month:** Pressing the up arrow key will increase the number selected by the cursor from -504 to +488 in increments of 8. Pressing the down arrow key will decrease the number selected by the cursor from -504 to +488 in increments of 8.

#### Verifying the New Time Setting

After pressing ENTER, the display will indicate “Entry accepted” and the new time value will be saved to the Real-Time Clock (RTC).

## 8.4 HOA Keypad Battery Replacement

If there is a problem with the entered time, the operator will indicate “Input error” and the screen will return to the time setting display.

### Canceling the Input

Pressing the ESC key will display “Aborted” on the operator, and no value will be saved to the RTC. Pressing OFF will abort the setting process without any display, and no setting changes will be saved to the RTC.

### Exiting from the Time Setting Screen Without Making Any Changes

If no changes are entered, the display will exit Real Time Clock Adjustment Display after a few seconds and no changes will be saved.

### Manual Clock Adjustment by Setting Z1-37 to 1

If time and date stamps are required by the user for faults and other data, the Real-time clock will need to be set upon receipt of the Bypass or after HOA keypad battery replacement.

*Refer to Z1-37: Set Time on page 206* for details on parameter Z1-37.

The following actions are possible in the Clock Adjustment Mode:

- Set the current time
- Check the time set to the drive Real-Time Clock

*Table 8.6* illustrates how to set the Real-Time Clock manually.

**Table 8.6 Manual Clock Adjustment Procedure**

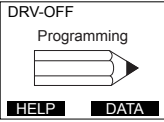
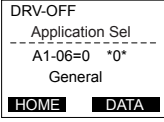
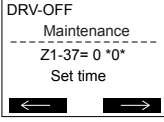
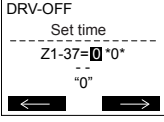
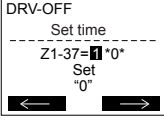
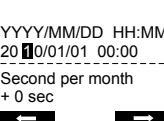
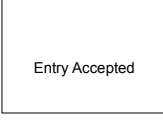
Procedure		Display
1	Use the up and down arrow keys to scroll through display menu until the screen shows “Programming”.	
2	Press the ENTER key to enter select the parameter setting mode.	
3	Use the up and down arrow keys to scroll through display menu until parameter Z1-37 appears.	
4	Press the ENTER key until “0” flashes.	
5	Press the up arrow key so that the display changes to “1”.	
6	Press the ENTER key and the time setting screen will appear. Use the right arrow key to select the desired digit, then set the correct date and time using the up and down arrow keys.	
7	After entering the correct time, press the ENTER key to save the changes.	

## 8.5 Drive Cooling Fans

**NOTICE:** Follow cooling fan replacement instructions. The cooling fan cannot operate properly when installed incorrectly and could seriously damage the drive. To ensure maximum useful product life, replace all cooling fans when performing maintenance.

Contact a Yaskawa representative or the nearest Yaskawa sales office to order replacement cooling fans as required.

For drives with multiple cooling fans, replace all the fans when performing maintenance to ensure maximum product performance life.

### ◆ Number of Cooling Fans

Z1000 Bypass Model Z1B1	Drive Model CIMR-Z□	Drive Cooling Fans	Drive Circulation Fans	Drive Control Board Cooling Fans	Bypass Enclosure Fans	Page
<b>Three-Phase 208 Vac</b>						
D002	2A0011	1	-	-	-	293
D003						
D004						
D007						
D010						
D016	2A0017	1	-	-	-	293
D024	2A0024	1	-	-	-	
D030	2A0031	1	-	-	-	
D046	2A0046	1	-	-	-	
D059	2A0059	1	-	-	-	
D074	2A0075	2	-	-	-	297
D088	2A0088	2	-	-	1	
D114	2A0114	2	-	-	1	
D143	2A0143	2	-	-	1	308
D169	2A0169	2	-	-	1	
D211	2A0211	2	-	-	0	
D273	2A0273	2	-	-	0	
—	2A0343	3	1	-	2	310
—	2A0396	3	1	-	2	
<b>Three-Phase 480 Vac</b>						
B001	4A0005	1	-	-	-	293
B002						
B003						
B004						
B007	4A0008	1	-	-	-	293
B011	4A0011	1	-	-	-	
B014	4A0014	1	-	-	-	
B021	4A0021	1	-	-	-	
B027	4A0027	1	-	-	-	
B034	4A0034	1	-	-	-	
B040	4A0040	1	-	-	-	
B52L	4A0052□□B	1	-	-	-	
B052	4A0052□□A	2	-	-	-	
B065	4A0065	2	-	-	-	
B077	4A0077	2	-	-	-	297
B096	4A0096	2	-	-	1	
B124	4A0124	1	-	-	1	
						302

## 8.5 Drive Cooling Fans

Z1000 Bypass Model Z1B1	Drive Model CIMR-Z□	Drive Cooling Fans	Drive Circulation Fans	Drive Control Board Cooling Fans	Bypass Enclosure Fans	Page
B156	4A0156	2	–	–	1	308
B180	4A0180	2	–	–	1	
B240	4A0240	2	–	–	0	
B302	4A0302	2	–	–	2	312

### ◆ Drive Cooling Fan Component Names

**WARNING! Electrical Shock Hazard.** Do not connect or disconnect wiring while the power is on. Failure to comply can result in serious personal injury. Before servicing, disconnect all power to the equipment. The internal capacitor remains charged even after the power supply is turned off. The charge indicator LED will extinguish when the DC bus voltage is below 50 Vdc. To prevent electric shock, wait for at least the time specified on the warning label, once all indicators are OFF, measure for unsafe voltages to confirm the drive is safe prior to servicing.

**CAUTION! Burn Hazard.** Do not touch a hot drive heatsink. Failure to comply could result in minor or moderate injury. Shut off the power to the drive when replacing the cooling fan. To prevent burns, wait at least 15 minutes and ensure the heatsink has cooled down.

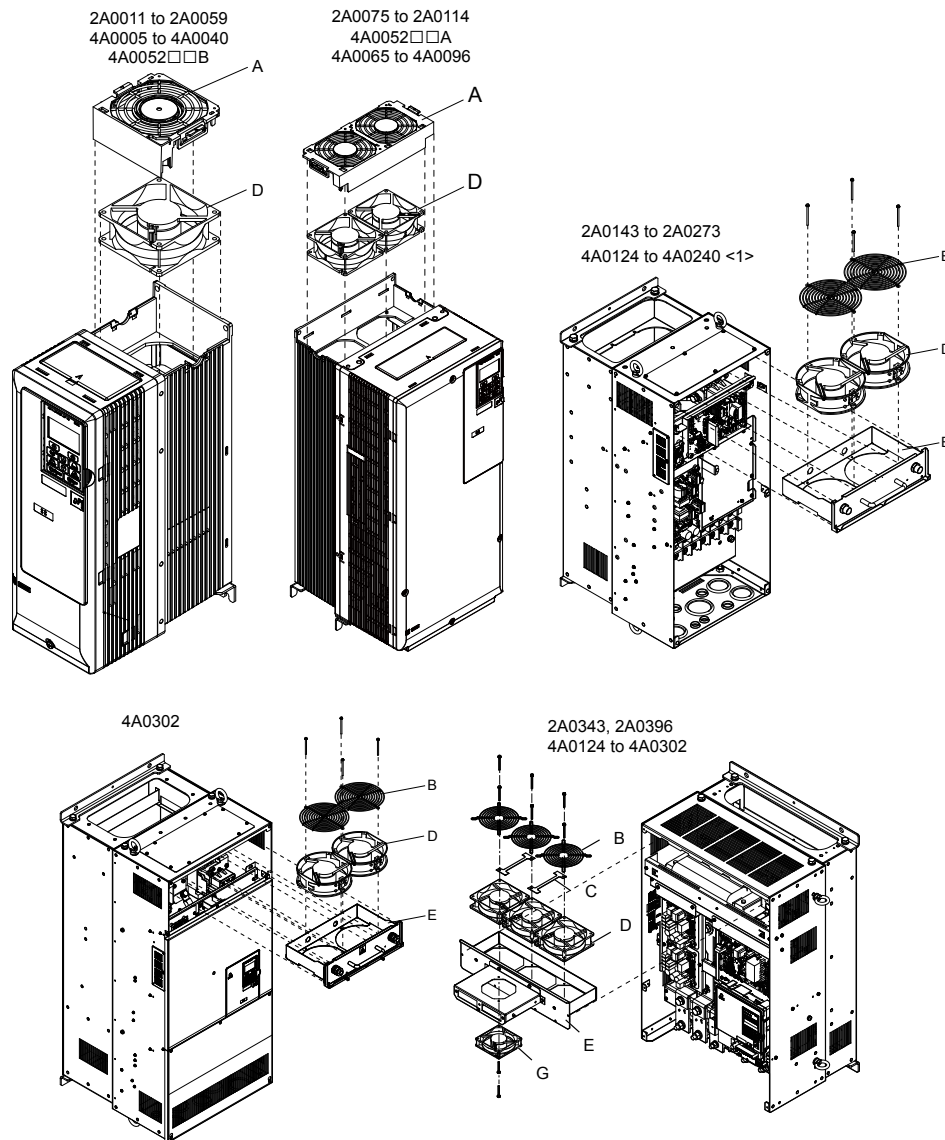

Figure 8.2 Cooling Fan Component Names

<1> Drive model CIMR-Z□4A0124 has a single cooling fan.

## ◆ Cooling Fan Replacement: 2A0011 to 2A0059, 4A0005 to 4A0040, and 4A0052□□B

When the heatsinks are externally mounted, these models enable access to the fans from the back or top of the drive when the fans need replacing.

The drive can also be dismantled when replacing the fans. When dismantling the drive, be careful not to damage the mounting flange gasket. If the gasket is damaged, contact a Yaskawa representative or the nearest Yaskawa sales office.

**WARNING! Electrical Shock Hazard.** Do not connect or disconnect wiring while the power is on. Failure to comply can result in serious personal injury. Before servicing, disconnect all power to the equipment. The internal capacitor remains charged even after the power supply is turned off. The charge indicator LED will extinguish when the DC bus voltage is below 50 Vdc. To prevent electric shock, wait for at least the time specified on the warning label, once all indicators are OFF, measure for unsafe voltages to confirm the drive is safe prior to servicing.

**CAUTION! Burn Hazard.** Do not touch a hot drive heatsink. Failure to comply could result in minor or moderate injury. Shut off the power to the drive when replacing the cooling fan. To prevent burns, wait at least 15 minutes and ensure the heatsink has cooled down.

**NOTICE:** Follow cooling fan replacement instructions. Improper fan replacement could cause damage to equipment. Make sure the fan is facing upwards when installing the replacement fan into the drive. Replace all fans when performing maintenance to help ensure maximum useful product life.

### ■ Removing the Cooling Fan Finger Guard and Cooling Fan: 2A0011 to 2A0059, 4A0005 to 4A0040, and 4A0052□□B

1. Depress the right and left sides of the fan cover tabs and pull upward. Remove the fan cover from the top of the drive. The following figure illustrates a drive with a single cooling fan.

**Note:** The cooling fan and finger guard are mechanically joined.

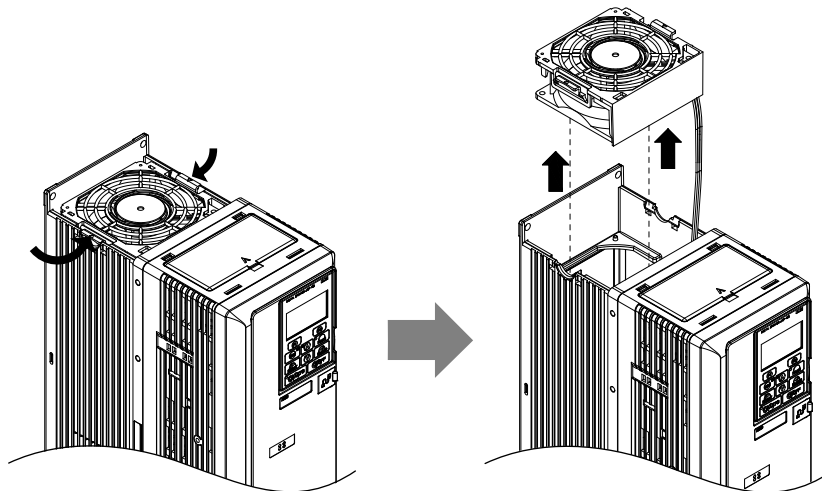

Figure 8.3 Remove the Cooling Fan Finger Guard: 2A0011 to 2A0059, 4A0005 to 4A0040, and 4A0052□□B

2. Unplug the protective tube and relay connector from the cooling fan unit.

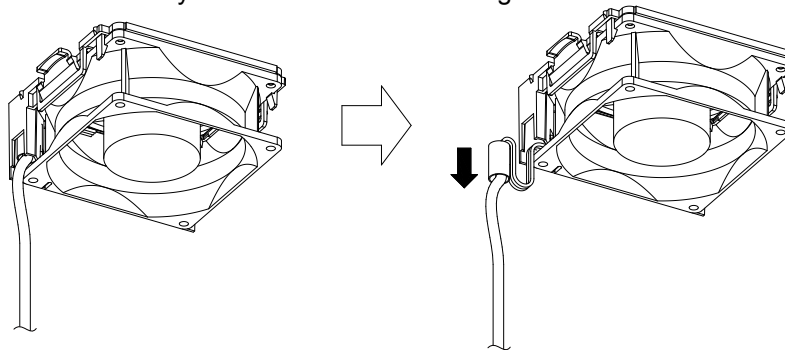
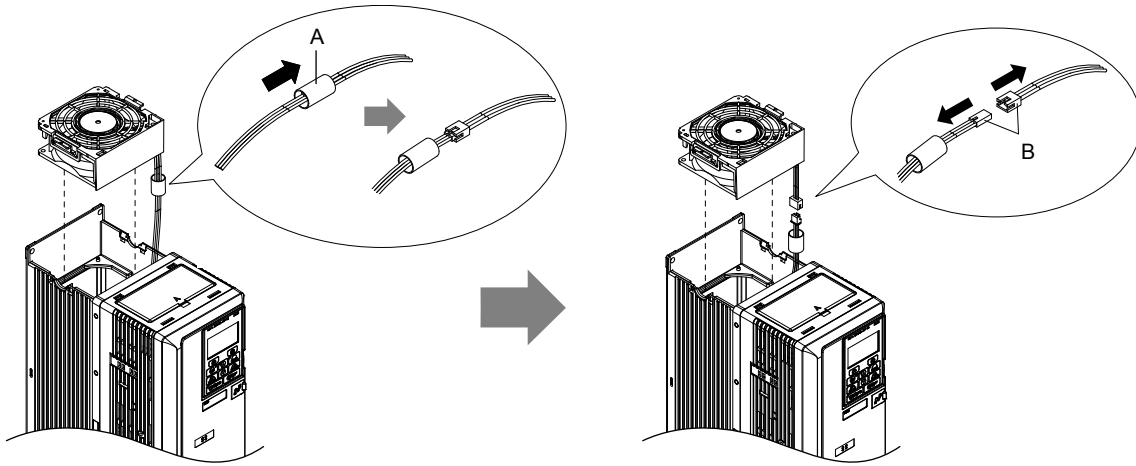

Figure 8.4 Unplug the Protective Tube and Relay Connector: 2A0011 to 2A0059, 4A0005 to 4A0040, and 4A0052□□B

3. Slide the protective tube towards the cooling fan to expose the connector. Unplug the connector.



**A – Protective tube**

**B – Fan connector**

**Figure 8.5 Remove the Fan Connector: 2A0011 to 2A0059, 4A0005 to 4A0040, and 4A0052□□B**

4. Pull back on the hook to free the cooling fan unit. Lift the cooling fan diagonally to remove it from the drive.

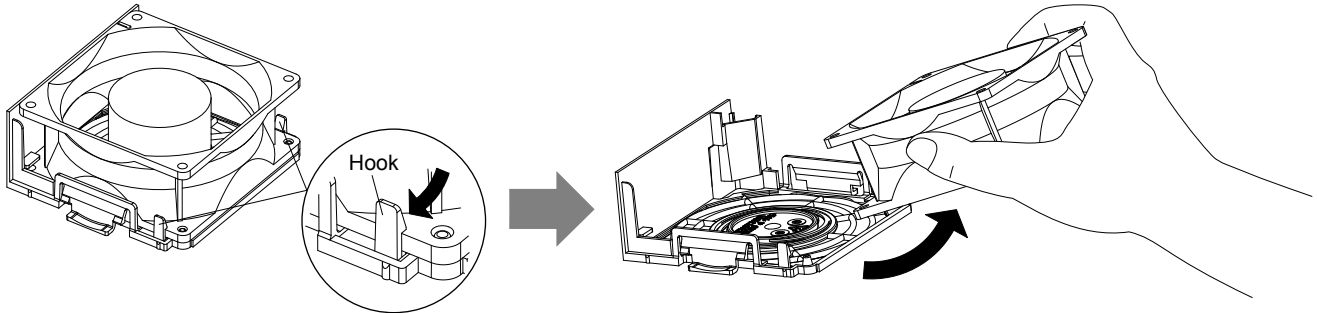

**Figure 8.6 Remove the Cooling Fan: 2A0011 to 2A0059, 4A0005 to 4A0040, and 4A0052□□B**

## ■ Installing the Cooling Fan: 2A0011 to 2A0059, 4A0005 to 4A0040, and 4A0052□□B

**NOTICE:** Prevent Equipment Damage. Follow cooling fan replacement instructions. Improper cooling fan replacement could result in damage to equipment. When installing the replacement cooling fan into the drive, make sure the fan is facing upwards. To ensure maximum useful product life, replace all cooling fans when performing maintenance.

Reverse the procedure described above to reinstall the cooling fan.

1. Line up the small alignment notch on the cooling fan and the corresponding protrusion on the fan finger guard.

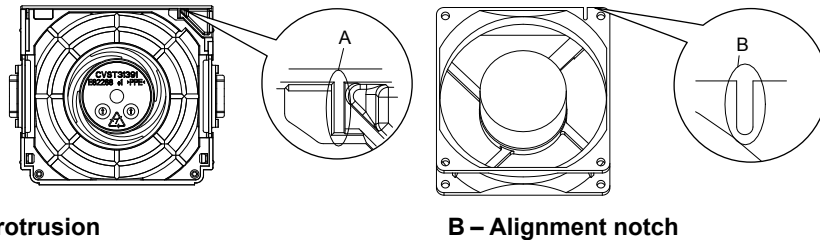

A – Protrusion

B – Alignment notch

Figure 8.7 Alignment Notch and Protrusion: 2A0011 to 2A0059, 4A0005 to 4A0040, and 4A0052□□B

2. Insert the cooling fan diagonally into the fan finger guard so the bosses and holes match. It should click into place.

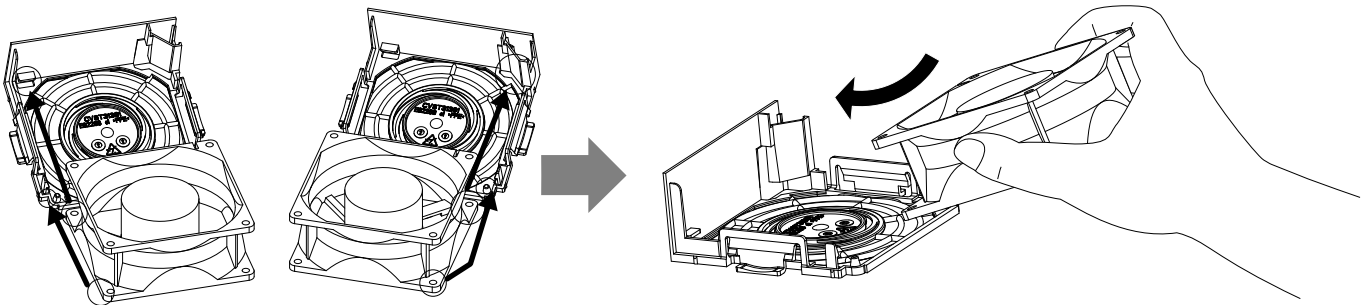
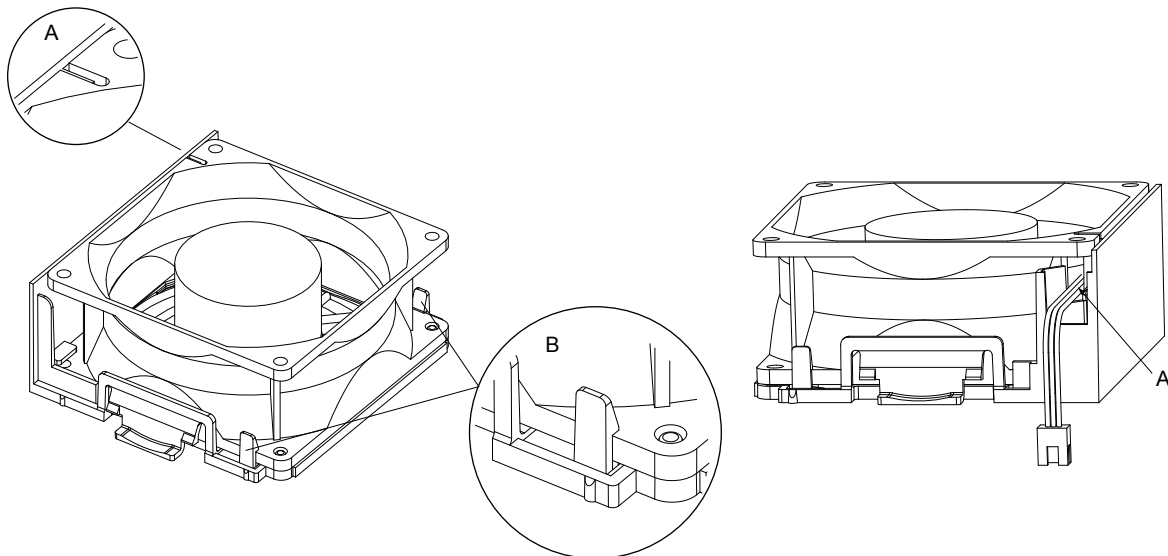

Figure 8.8 Insert the Cooling Fan into the Fan Finger Guard: 2A0011 to 2A0059, 4A0005 to 4A0040, and 4A0052□□B

3. Make sure that the cooling fan has been correctly inserted into the fan finger guard.



A – Alignment notches should fit into the corresponding protrusions.

B – Hooks should hold the cooling fan tightly, and the bosses should align properly with the corresponding holes.

Figure 8.9 Check the Placement of the Fan Finger Guard: 2A0011 to 2A0059, 4A0005 to 4A0040, and 4A0052□□B

4. Plug the fan connector, then slide the protective cover over the connector.

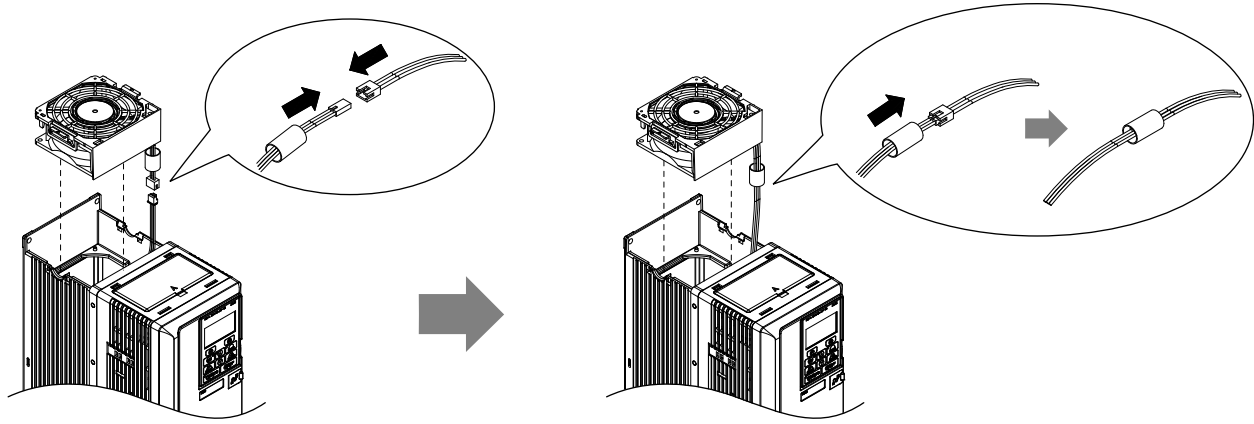

Figure 8.10 Plug the Fan Connector: 2A0011 to 2A0059, 4A0005 to 4A0040, and 4A0052□□B

5. Push the fan connector and protective tube into the fan finger guard.

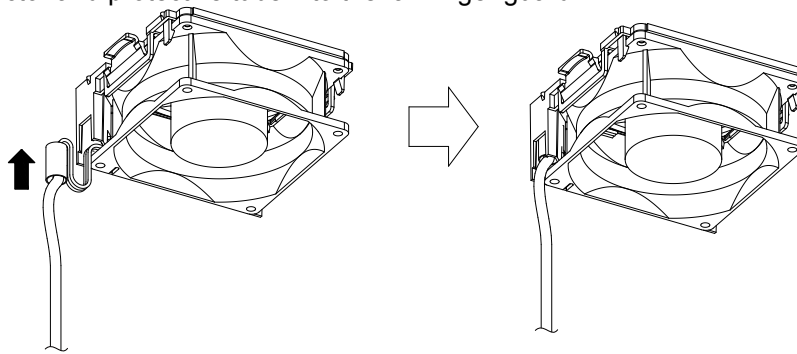

Figure 8.11 Placement of Fan Connector and Protective Tube: 2A0011 to 2A0059, 4A0005 to 4A0040, and 4A0052□□B

6. While pressing in on the hooks on the left and right sides of the fan finger guard, guide the fan finger guard until it clicks into place.

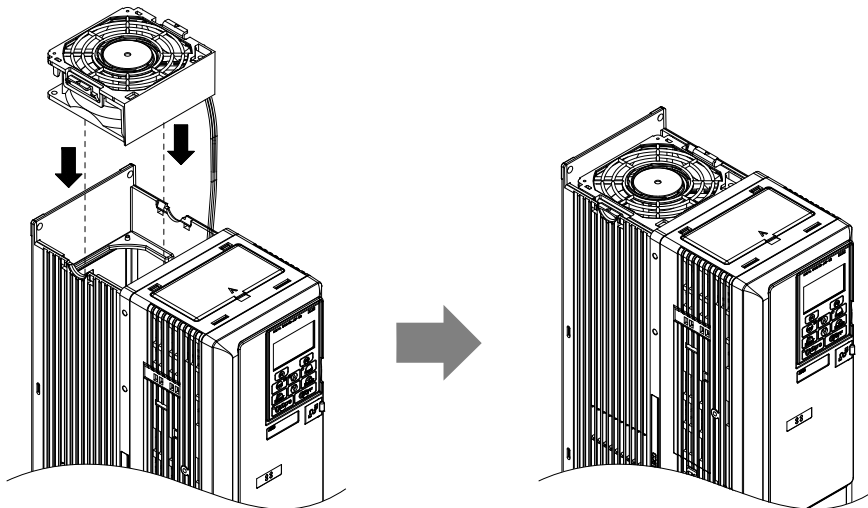

Figure 8.12 Reattach the Cooling Fan and Fan Finger Guard: 2A0011 to 2A0059, 4A0005 to 4A0040, and 4A0052□□B



## ◆ Cooling Fan Replacement: 2A0075 to 2A0114, 4A0052□□A, and 4A0065 to 4A0096

When the heatsinks are externally mounted, these models enable access to the fans from the back or top of the drive when the fans need replacing.

The drive can also be dismantled when replacing the fans. When dismantling the drive, be careful not to damage the mounting flange gasket. If the gasket is damaged, contact a Yaskawa representative or the nearest Yaskawa sales office.

**WARNING! Electrical Shock Hazard.** Do not connect or disconnect wiring while the power is on. Failure to comply can result in serious personal injury. Before servicing, disconnect all power to the equipment. The internal capacitor remains charged even after the power supply is turned off. The charge indicator LED will extinguish when the DC bus voltage is below 50 Vdc. To prevent electric shock, wait for at least the time specified on the warning label, once all indicators are OFF, measure for unsafe voltages to confirm the drive is safe prior to servicing.

**CAUTION! Burn Hazard.** Do not touch a hot drive heatsink. Failure to comply could result in minor or moderate injury. Shut off the power to the drive when replacing the cooling fan. To prevent burns, wait at least 15 minutes and ensure the heatsink has cooled down.

**NOTICE:** Follow cooling fan and circulation fan replacement instructions. Improper fan replacement may cause damage to equipment. When installing the replacement fan into the drive, make sure the fan is facing upwards. Replace all fans when performing maintenance to help ensure maximum useful product life.

### ■ Removing the Cooling Fan Finger Guard and Cooling Fan: 2A0075 to 2A0114, 4A0052□□A, and 4A0065 to 4A0096

1. Depress the right and left sides of the fan finger guard tabs and pull upward. Remove the cooling fan and the finger guard from the top of the drive.

**Note:** The cooling fan and cooling fan finger guard are mechanically joined.

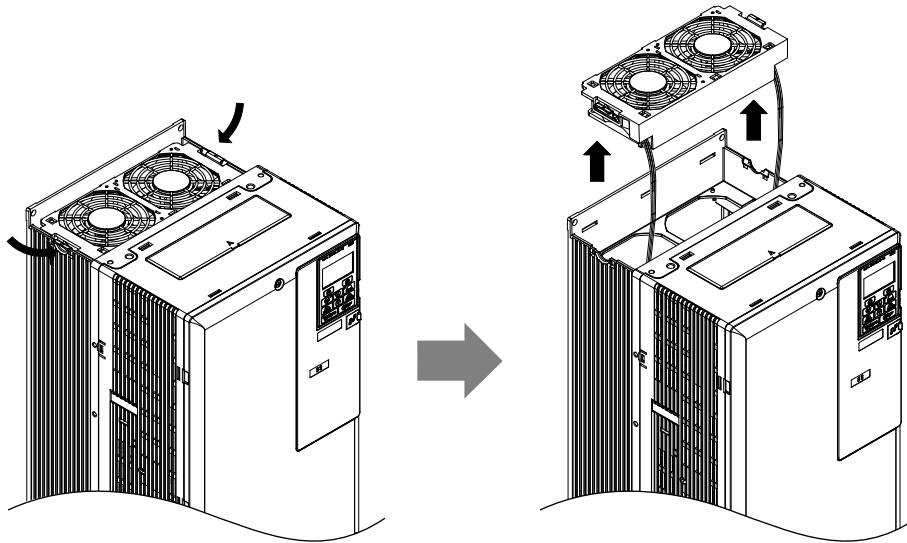

Figure 8.13 Remove the Cooling Fan Finger Guard and Cooling Fan: 2A0075 to 2A0114, 4A0052□□A, and 4A0065 to 4A0096

2. Unplug the protective tube and the fan connector from the cooling fan unit.

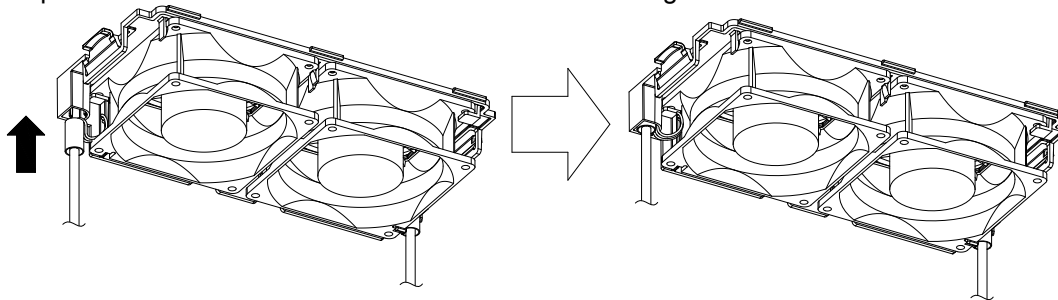

Figure 8.14 Unplug the Protective Tube and Fan Connector: 2A0075 to 2A0114, 4A0052□□A, and 4A0065 to 4A0096

3. Slide the protective tube toward the cooling fan to expose the fan connector, then unplug the connector.

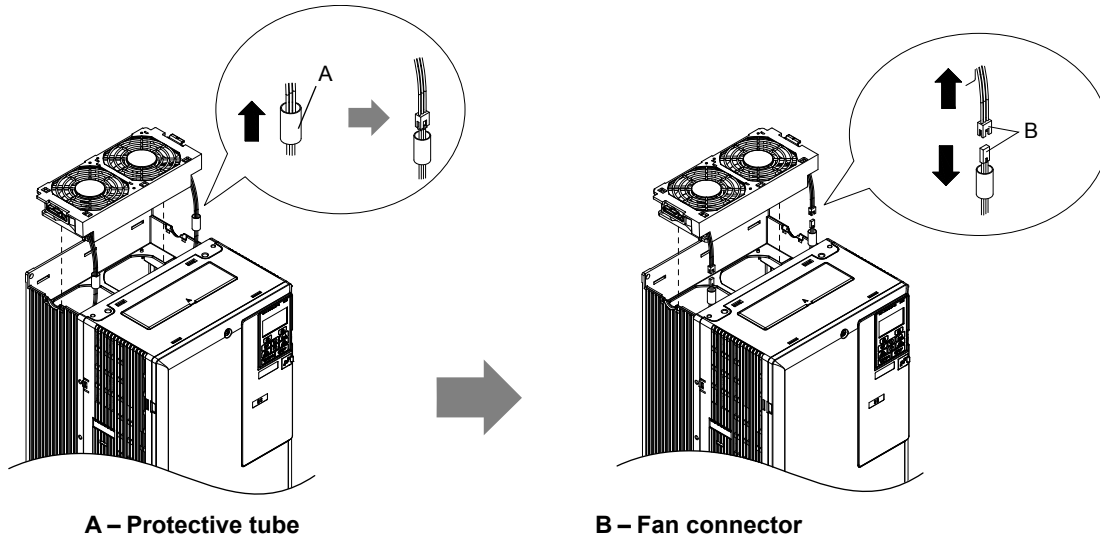

Figure 8.15 Remove the Fan Connector: 2A0075 to 2A0114, 4A0052□□A, and 4A0065 to 4A0096

4. Pull back on the two fan hooks on the **right** side of the cooling fan unit, then lift the **right-side** fan diagonally to remove it from the drive. Repeat the process for the left-side cooling fan unit.

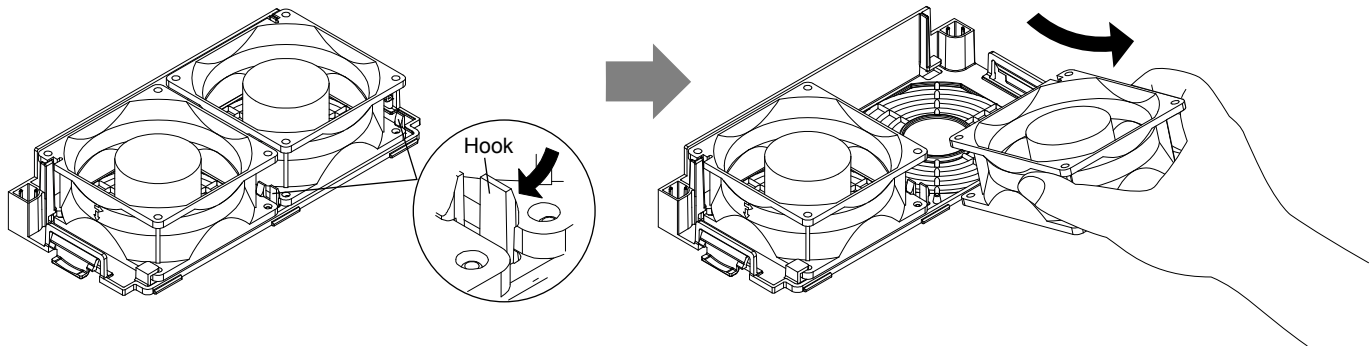

Figure 8.16 Remove the Right-Side Cooling Fan: 2A0075 to 2A0114, 4A0052□□A, and 4A0065 to 4A0096

### ■ Installing the Cooling Fan: 2A0075 to 2A0114, 4A0052□□A, and 4A0065 to 4A0096

1. Insert the **left-side** cooling fan diagonally into the fan finger guard so that the bosses and holes match. It should click into place.

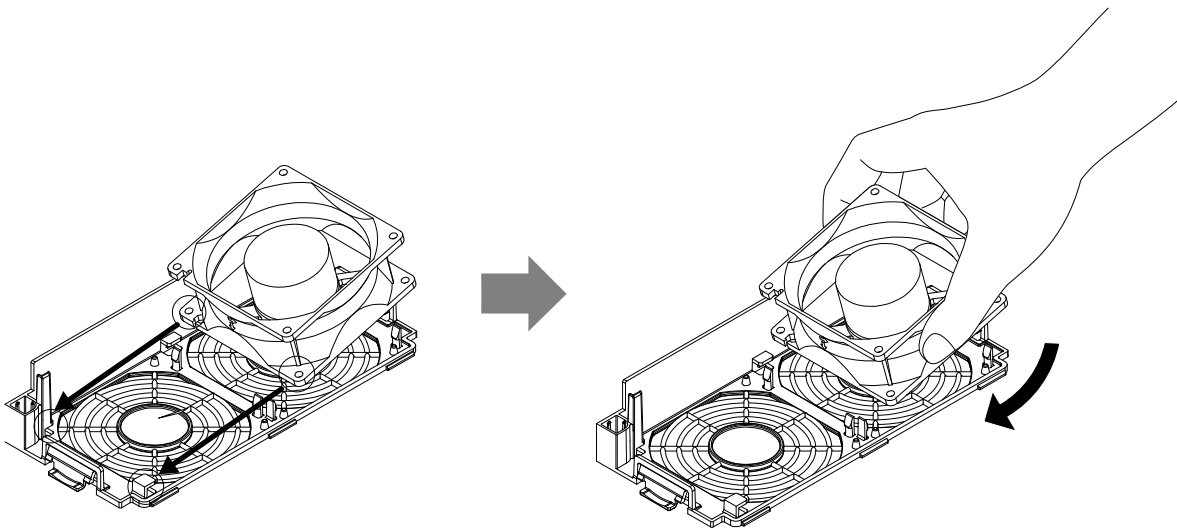
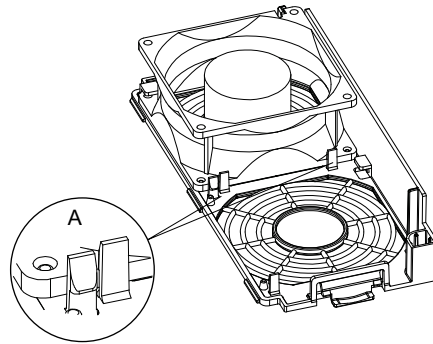

Figure 8.17 Insert the Left-Side Cooling Fan into the Fan Finger Guard: 2A0075 to 2A0114, 4A0052□□A, and 4A0065 to 4A0096

2. Make sure that the **left-side** cooling fan has been inserted correctly into the fan finger guard.



A –Alignment notches should fit into the corresponding protrusions.

Figure 8.18 Check the Placement of the Fan Finger Guard: 2A0075 to 2A0114, 4A0052□□A, and 4A0065 to 4A0096

3. Insert the **right-side** cooling fan diagonally into the fan finger guard. It should click into place.

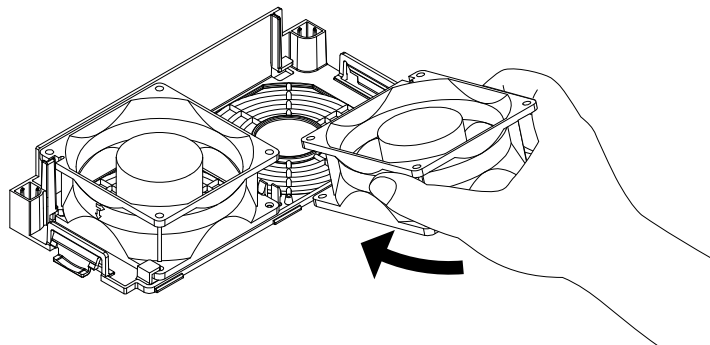
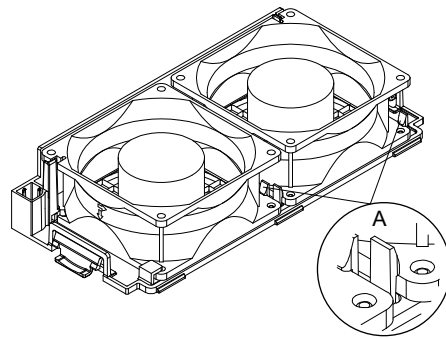

Figure 8.19 Insert the Right-Side Cooling Fan into the Fan Finger Guard: 2A0075 to 2A0114, 4A0052□□A, and 4A0065 to 4A0096

4. Make sure that the **right-side** cooling fan has been inserted correctly into the fan finger guard.



**A** –Alignment notches should fit into the corresponding protrusions.

**Figure 8.20** Check the Placement of the Fan Finger Guard: 2A0075 to 2A0114, 4A0052□□A, and 4A0065 to 4A0096

5. Plug the fan connector, then slide the protective cover over the connector.

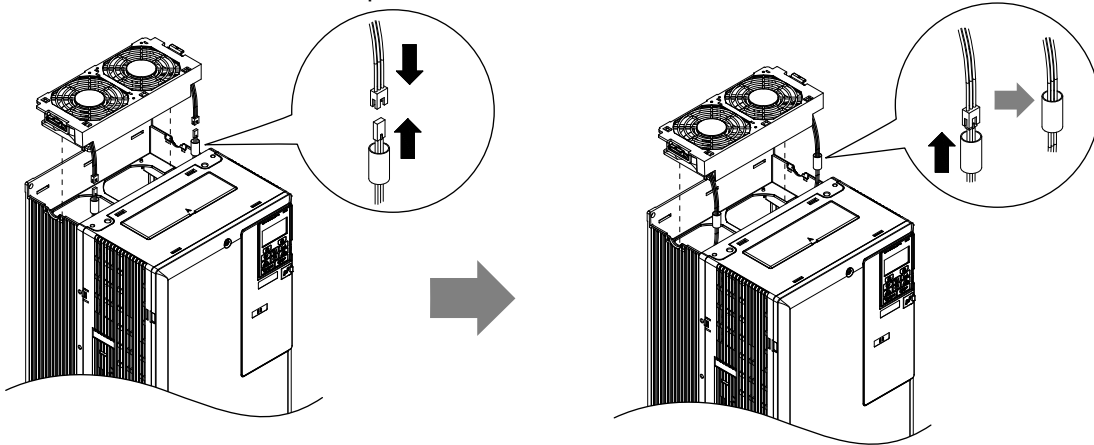

**Figure 8.21** Plug the Fan Connector: 2A0075 to 2A0114, 4A0052□□A, and 4A0065 to 4A0096

6. Push the fan connector and protective tube into the fan finger guard.

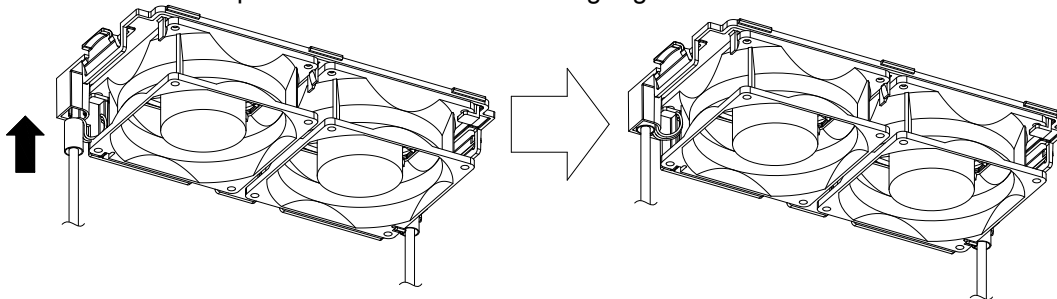

**Figure 8.22** Placement of Fan Connector and Protective Tube: 2A0075 to 2A0114, 4A0052□□A, and 4A0065 to 4A0096

7. While pressing in on the hooks on the left and right sides of the fan finger guard, guide the fan finger guard until it clicks into place.

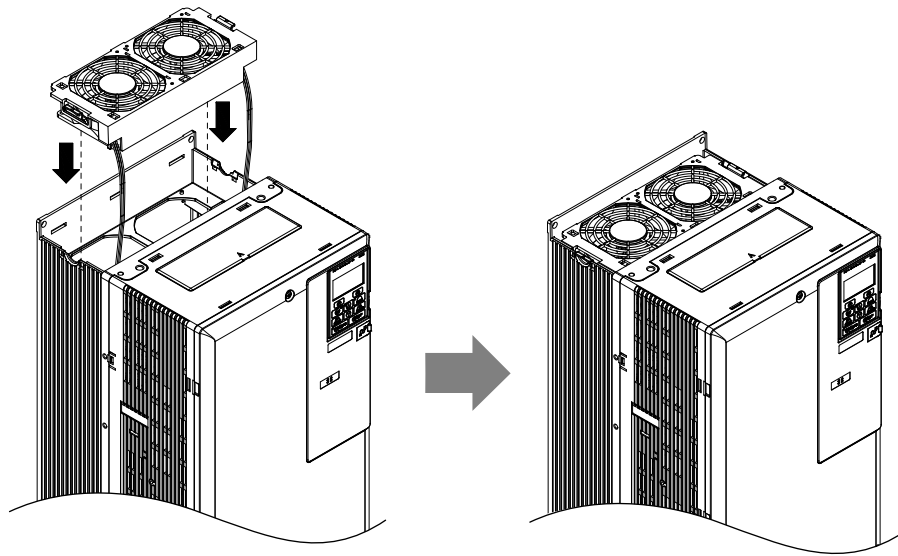

Figure 8.23 Reattach the Cooling Fan and Fan Finger Guard: 2A0075 to 2A0114, 4A0052□□A, and 4A0065 to 4A0096

### ◆ Cooling Fan Replacement: 4A0124

**WARNING! Electrical Shock Hazard.** Do not connect or disconnect wiring while the power is on. Failure to comply can result in serious personal injury. Before servicing, disconnect all power to the equipment. The internal capacitor remains charged even after the power supply is turned off. The charge indicator LED will extinguish when the DC bus voltage is below 50 Vdc. To prevent electric shock, wait for at least the time specified on the warning label, once all indicators are OFF, measure for unsafe voltages to confirm the drive is safe prior to servicing.

**CAUTION! Burn Hazard.** Do not touch a hot drive heatsink. Failure to comply could result in minor or moderate injury. Shut off the power to the drive when replacing the cooling fan. To prevent burns, wait at least 15 minutes and ensure the heatsink has cooled down.

**NOTICE:** Follow cooling fan and circulation fan replacement instructions. Improper fan replacement may cause damage to equipment. When installing the replacement fan into the drive, make sure the fan is facing upwards. Replace all fans when performing maintenance to help ensure maximum useful product life.

### ■ Removing and Disassembling the Cooling Fan Unit: 4A0124

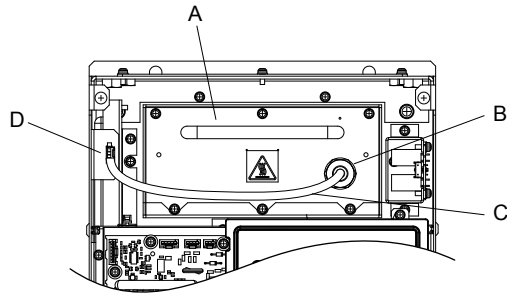

A – Fan unit  
B – Cable gland

C – Fan cable  
D – Relay connector

Figure 8.24 Cooling Fan Replacement: 4A0124

1. Remove the terminal cover. Refer to the User Manual packaged with the drive for details on removing the terminal cover.
2. Loosen the four screws on the drive cover.

**CAUTION!** Be sure to keep a firm grip on the drive cover when removing it from the drive. Failure to comply may result in minor or moderate injury from the cover falling.

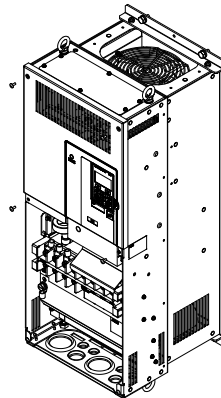

Figure 8.25 Loosen the Screws on the Drive Cover: 4A0124

3. Pull forward on the drive cover to free it from the drive.

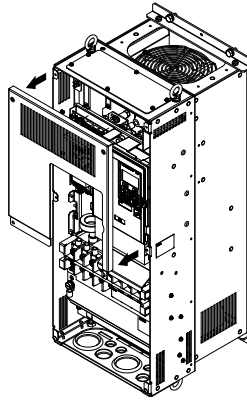
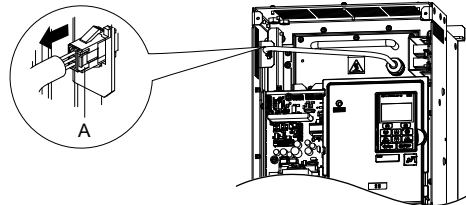

Figure 8.26 Remove the Drive Cover: 4A0124

4. Pull out the relay connector and loosen the cap of the cable gland to remove the fan cable.



A –Relay connector

Figure 8.27 Remove the Relay Connector and Loosen the Cable Gland: 4A0124

5. Remove the screws holding the fan unit in place and slide the cooling fan unit out of the drive.

**CAUTION!** *Injury to Personnel. Use two hands to remove the fan unit. Failure to comply may cause the fan unit to fall, resulting in minor to moderate injury.*

**Note:** Use a magnetized screwdriver when removing the screws to prevent the screws from falling.

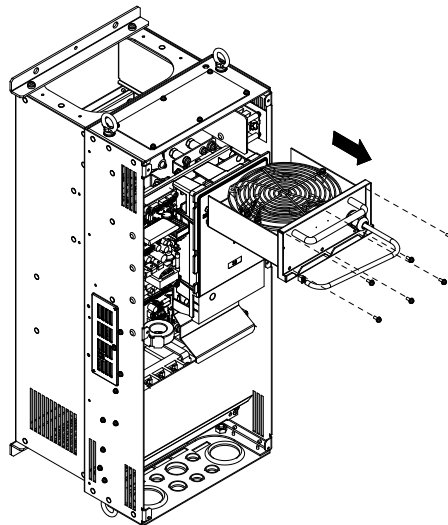

Figure 8.28 Remove the Cooling Fan Unit: 4A0124

6. Unscrew and remove the sealing nut. Yaskawa recommends using a wrench from AVC Corp. of Japan or equivalent.

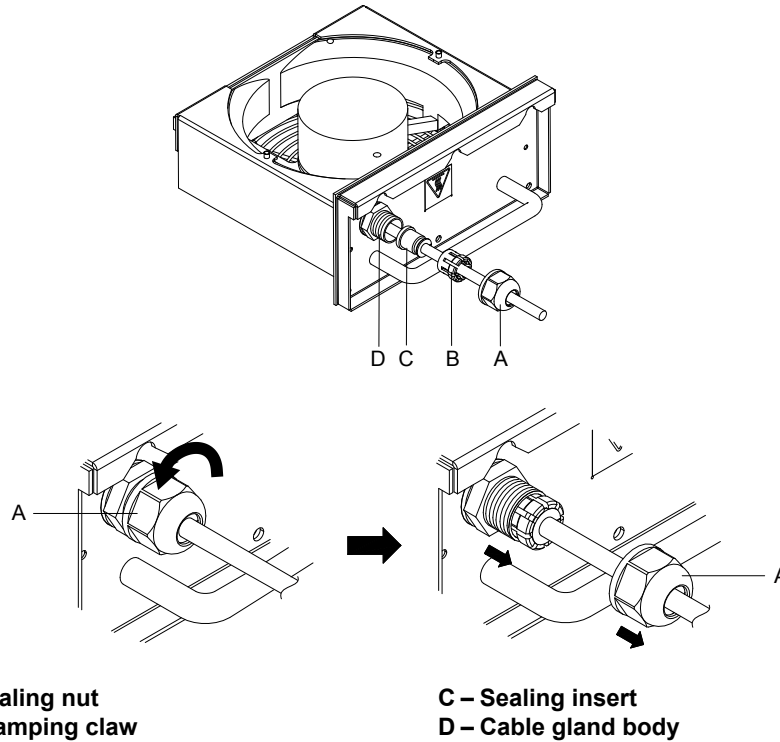

Figure 8.29 Cooling Fan Cable Gland: 4A0124

7. Pull the clamp claw and sealing nut insert from the gland body and separate the pieces.

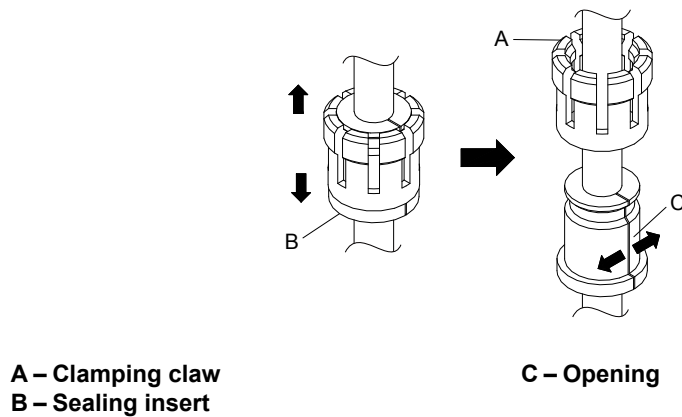
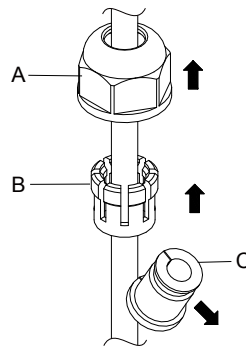

Figure 8.30 Separate the Clamping Claw and Sealing Insert: 4A0124

8. Pull apart the opening on the sealing insert then remove it from the wiring. Slide the sealing nut and clamping claw off the power lines.





A – Sealing nut  
B – Sealing insert

C – Clamping claw

Figure 8.31 Remove the Cable Gland: 4A0124

9. Turn the fan unit over and replace the cooling fan. Install the fan so the air flows upward.

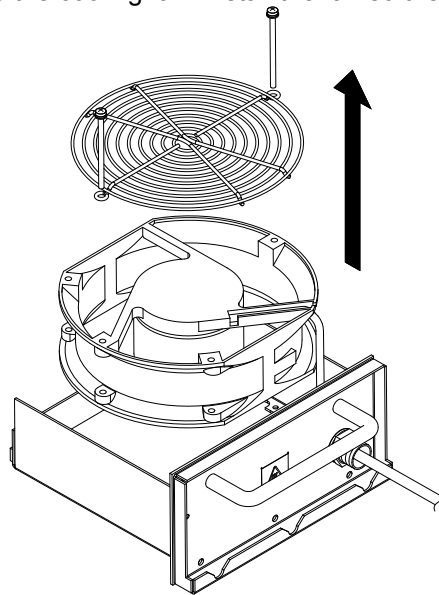
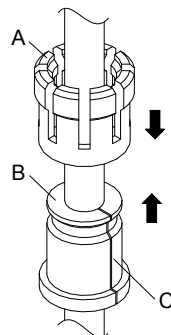

Figure 8.32 Replace the Cooling Fan: 4A0124

### ■ Installing the Cooling Fan Unit: 4A0124

**Note:** Do not pinch the fan cable between parts when reassembling the fan unit.

1. Allow the fan cable to pass through the cable gland body, then pull apart the opening in the sealing insert and fit the insert around the cable.



A – Clamping claw  
B – Sealing insert

C – Opening

Figure 8.33 Reassemble the Cable Gland: 4A0124

## 8.5 Drive Cooling Fans

2. Assemble the clamping claw and sealing insert.

**Note:** The clamping claw and sealing insert should fit together so that no opening remains and the sealing insert is not deformed.

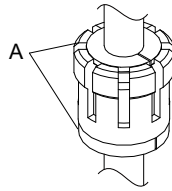

**A** – No opening remains and the sealing insert is not deformed.

**Figure 8.34 Clamping Claw and Sealing Insert: 4A0124**

3. Place the clamping claw and sealing insert into the cable gland body then tighten the sealing nut into place.

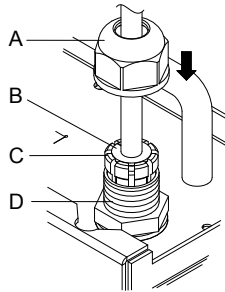

**A** – Sealing nut  
**B** – Sealing insert

**C** – Clamping claw  
**D** – Cable gland body

**Figure 8.35 Reassemble the Cable Gland: 4A0124**

4. The remaining space between the sealing nut and the clamping claw should be between 2.5 and 3.0 mm (0.10 to 0.12 in).

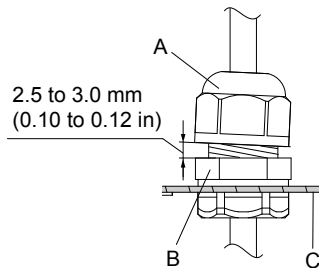

**A** – Sealing nut  
**B** – Cable gland body

**C** – Fan unit

**Figure 8.36 Cable Gland: 4A0124**

5. Insert the cooling fan into the drive.

**Note:** Use a magnetized screwdriver when inserting the screws to prevent the screws from falling.

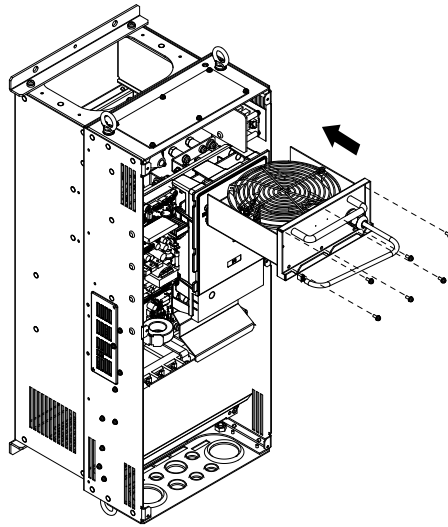

Figure 8.37 Insert the Cooling Fan Unit: 4A0124

6. Reverse procedure steps 2 and 3 in [Removing and Disassembling the Cooling Fan Unit: 4A0124](#) to reattach the drive cover. After reattaching the drive cover, reattach the terminal cover. Refer to the User Manual packaged with the drive for details on reattaching the terminal cover.

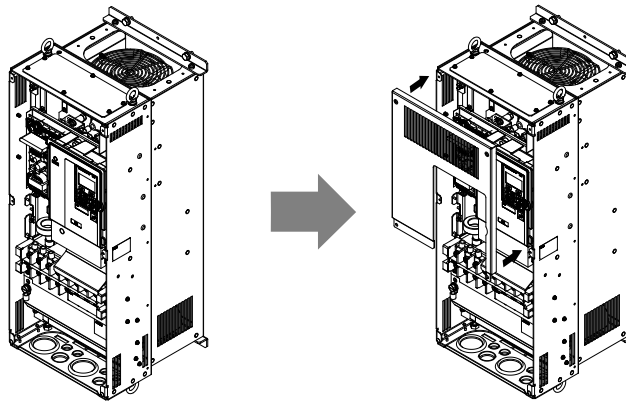

Figure 8.38 Reattach the Drive Cover: 4A0124

7. Turn on the power supply and set o4-03 to 0 to reset the Maintenance Monitor cooling fan operation time.

### ◆ Cooling Fan Replacement: 2A0143 to 2A0273, 4A0156 to 4A0240

**WARNING! Electrical Shock Hazard.** Do not connect or disconnect wiring while the power is on. Failure to comply can result in serious personal injury. Before servicing, disconnect all power to the equipment. The internal capacitor remains charged even after the power supply is turned off. The charge indicator LED will extinguish when the DC bus voltage is below 50 Vdc. To prevent electric shock, wait for at least the time specified on the warning label, once all indicators are OFF, measure for unsafe voltages to confirm the drive is safe prior to servicing.

**CAUTION! Burn Hazard.** Do not touch a hot drive heatsink. Failure to comply could result in minor or moderate injury. Shut off the power to the drive when replacing the cooling fan. To prevent burns, wait at least 15 minutes and ensure the heatsink has cooled down.

**NOTICE:** Follow cooling fan and circulation fan replacement instructions. Improper fan replacement may cause damage to equipment. When installing the replacement fan into the drive, make sure the fan is facing upwards. Replace all fans when performing maintenance to help ensure maximum useful product life.

### ■ Removing and Disassembling the Cooling Fan Unit: 2A0143 to 2A0273, 4A0156 to 4A0240

1. Remove the covers.

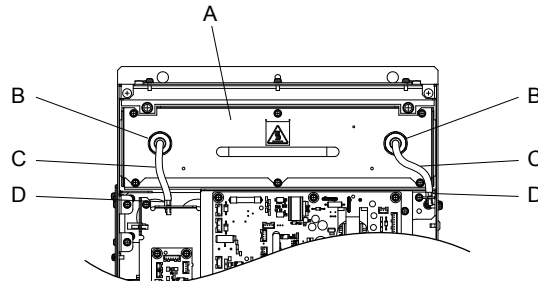

A – Fan unit

B – Ground cables

C – Fan cables

D – Relay connectors

Figure 8.39 Cooling Fan Replacement: 2A0143 to 2A0273, 4A0156 to 4A0240

2. Pull out the two relay connectors and loosen the ground cable caps to remove the fan cables.

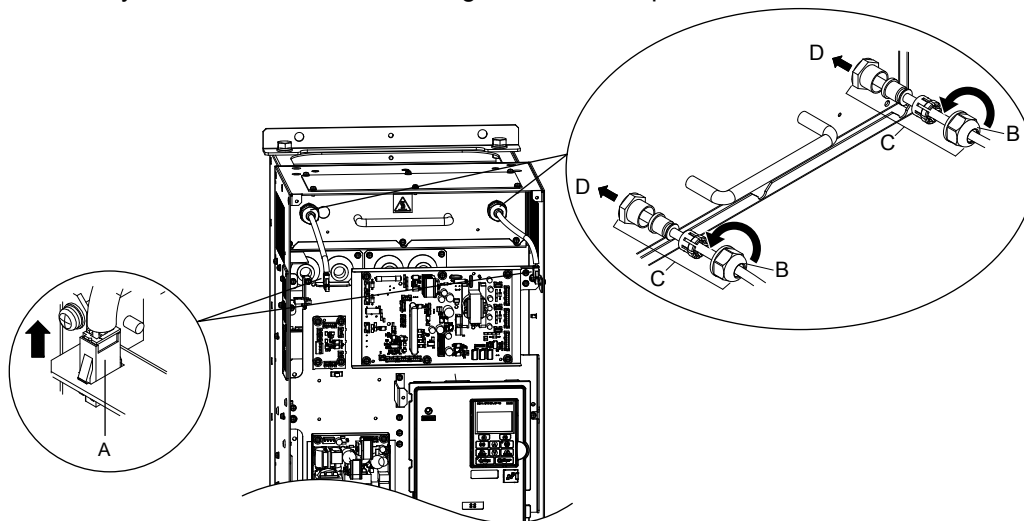

A – Relay connectors

B – Caps

C – Ground cables

D – Remove the fan cables

Figure 8.40 Remove the Relay Connector and Loosen the Cable Ground: 2A0143 to 2A0273, 4A0156 to 4A0240

3. Remove the screws holding the cooling fan unit in place and slide the fan unit out of the drive.

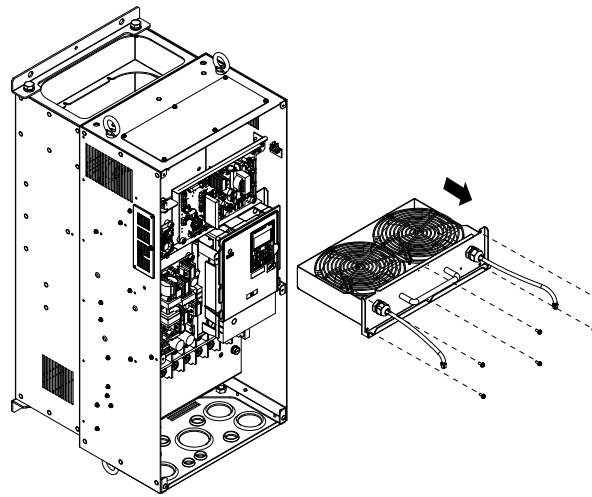
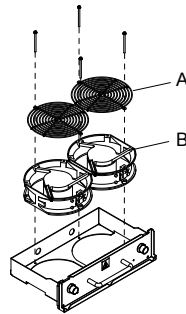

Figure 8.41 Remove the Cooling Fan Unit: 2A0143 to 2A0273, 4A0156 to 4A0240

4. Remove the fan guards and replace the cooling fans.



A – Fan guards

B – Cooling fans

Figure 8.42 Cooling Fan Disassembly: 2A0143 to 2A0273, 4A0156 to 4A0240

### ■ Installing the Cooling Fan Unit: 2A0143 to 2A0273, 4A0156 to 4A0240

1. Reverse the procedure to reinstall the cooling fan unit.

**Note:** Do not pinch the fan cable between parts when reassembling the fan unit.

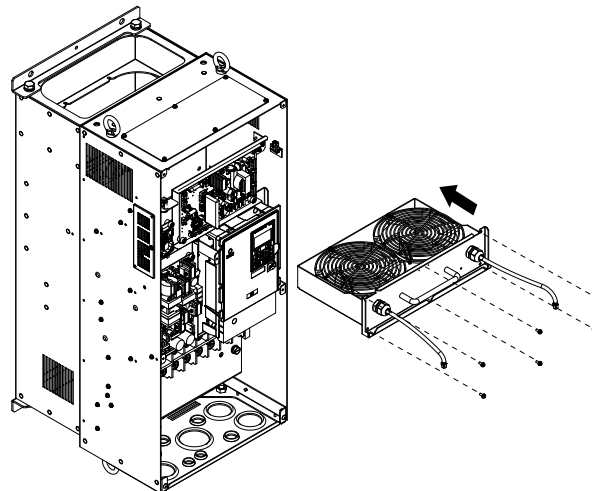

Figure 8.43 Insert the Cooling Fan Unit: 2A0143 to 2A0273, 4A0156 to 4A0240

2. Reattach the covers.
3. Turn on the power supply and set o4-03 to 0 to reset the Maintenance Monitor cooling fan operation time.

### ◆ Cooling Fan Replacement: 2A0343 and 2A0396

**WARNING! Electrical Shock Hazard.** Do not connect or disconnect wiring while the power is on. Failure to comply can result in serious personal injury. Before servicing, disconnect all power to the equipment. The internal capacitor remains charged even after the power supply is turned off. The charge indicator LED will extinguish when the DC bus voltage is below 50 Vdc. To prevent electric shock, wait for at least the time specified on the warning label, once all indicators are OFF, measure for unsafe voltages to confirm the drive is safe prior to servicing.

**CAUTION! Burn Hazard.** Do not touch a hot drive heatsink. Failure to comply could result in minor or moderate injury. Shut off the power to the drive when replacing the cooling fan. To prevent burns, wait at least 15 minutes and ensure the heatsink has cooled down.

**NOTICE:** Follow cooling fan and circulation fan replacement instructions. Improper fan replacement may cause damage to equipment. When installing the replacement fan into the drive, make sure the fan is facing upwards. Replace all fans when performing maintenance to help ensure maximum useful product life.

### ■ Removing and Disassembling the Cooling Fan Unit: 2A0343 and 2A0396

1. Remove the terminal cover and front cover.
2. Remove the fan connectors (CN6, CN7).

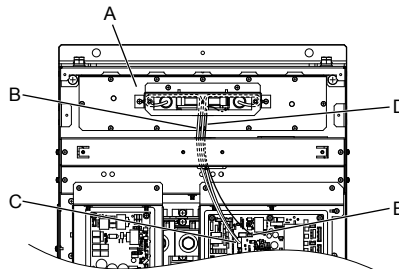

A – Fan unit  
B – Fan relay cable  
C – Fan connector (CN6)

D – Circulation fan relay cable  
E – Fan connector (CN7)

Figure 8.44 Cooling Fan Replacement: 2A0343 and 2A0396

3. Remove the screws holding the fan unit in place and slide the fan unit out of the drive.

**CAUTION! Injury to Personnel.** Use two hands to remove the fan unit. Failure to comply may cause the fan unit to fall, resulting in minor to moderate injury.

**Note:** Use a magnetized screwdriver when removing the screws to prevent the screws from falling.

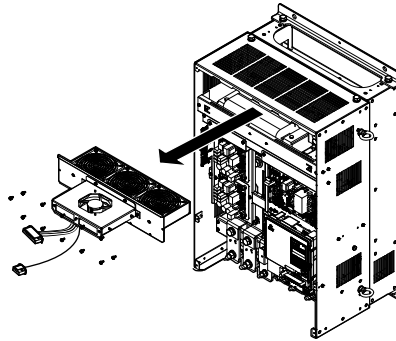
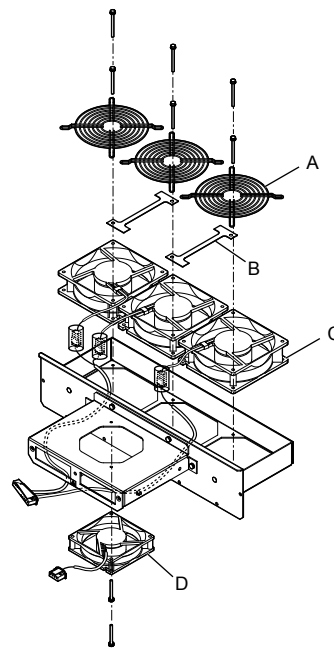

Figure 8.45 Remove the Fan Unit: 2A0343 and 2A0396

4. Remove the fan guard and replace the cooling fans.

**Note:** Do not pinch the fan cable between parts when reassembling the fan unit.



A – Fan guard  
B – Cable cover

C – Cooling fan  
D – Circulation fan

Figure 8.46 Fan Unit Disassembly: 2A0343 and 2A0396

### ■ Cooling Fan Wiring: 2A0343 and 2A0396

1. Position the protective tube so the fan connector sits in the center of the protective tube.

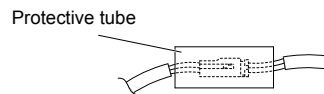

2. In the space between fans 1 and 2, place the fan connector for fan B2 in front of the fan connector for fan B1.
3. Place the connector for fan B3 between fans B2 and B3.

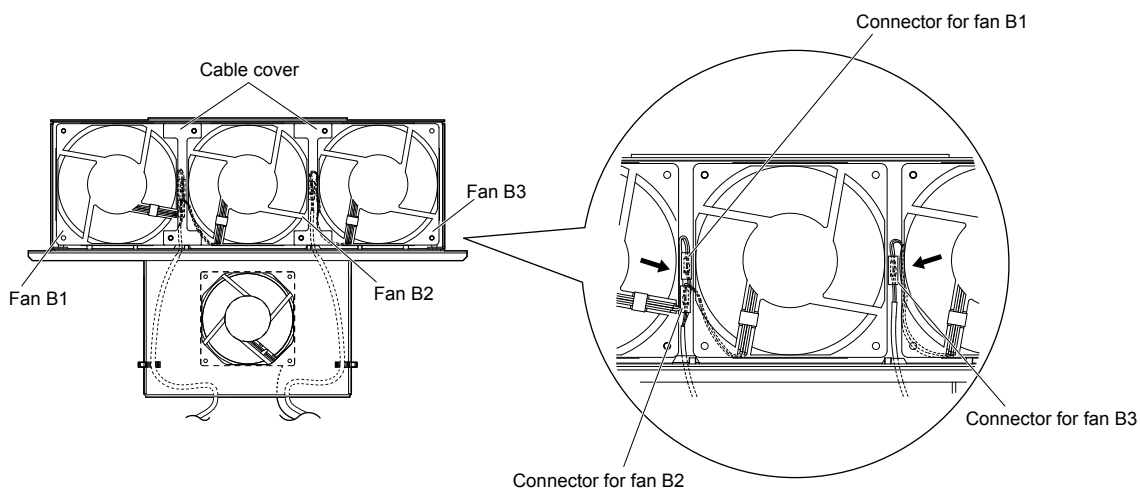

Figure 8.47 Cooling Fan Wiring: 2A0343 and 2A0396

4. Double-check the relay connector to ensure it is properly connected.
5. Reattach the cable cover to its original position and tighten the screws so the fan guard holds the cable cover in place.

**Note:** Do not pinch the fan cable between parts when reassembling the fan unit.

### ■ Installing the Cooling Fan Unit: 2A0343 and 2A0396

1. Reverse the procedure described above to reinstall the cooling fan unit.

**Note:** Use a magnetized screwdriver when inserting the screws to prevent the screws from falling.

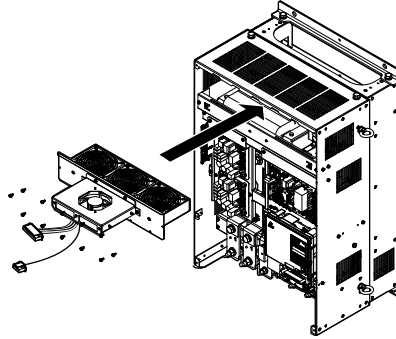

Figure 8.48 Install the Cooling Fan Unit: 2A0343 and 2A0396

2. Reattach the covers and HOA keypad.
3. Turn on the power supply and set o4-03 to 0 to reset the Maintenance Monitor cooling fan operation time.

### ◆ Cooling Fan Replacement: 4A0302

**WARNING!** *Electrical Shock Hazard. Do not connect or disconnect wiring while the power is on. Failure to comply can result in serious personal injury. Before servicing, disconnect all power to the equipment. The internal capacitor remains charged even after the power supply is turned off. The charge indicator LED will extinguish when the DC bus voltage is below 50 Vdc. To prevent electric shock, wait for at least the time specified on the warning label, once all indicators are OFF, measure for unsafe voltages to confirm the drive is safe prior to servicing.*

**CAUTION!** *Burn Hazard. Do not touch a hot drive heatsink. Failure to comply could result in minor or moderate injury. Shut off the power to the drive when replacing the cooling fan. To prevent burns, wait at least 15 minutes and ensure the heatsink has cooled down.*

**NOTICE:** *Follow cooling fan and circulation fan replacement instructions. Improper fan replacement may cause damage to equipment. When installing the replacement fan into the drive, make sure the fan is facing upwards. Replace all fans when performing maintenance to help ensure maximum useful product life.*

### ■ Removing and Disassembling the Cooling Fan Unit: 4A0302

1. Remove the covers.

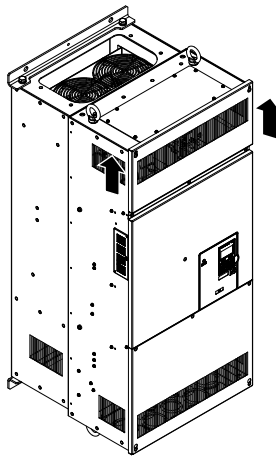
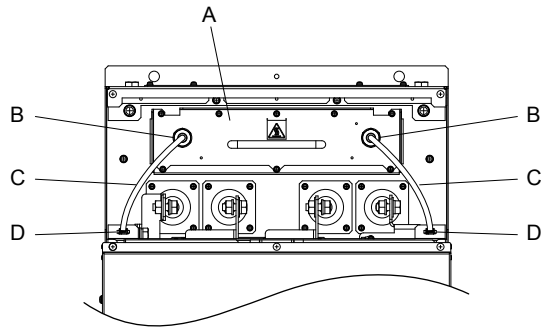

Figure 8.49 Remove the Front Cover: 4A0302





A – Fan unit  
 B – Ground cables  
 C – Fan cables  
 D – Relay connectors

Figure 8.50 Cooling Fan Replacement: 4A0302

2. Pull out the two relay connectors and loosen the ground cable caps to remove the fan cable.

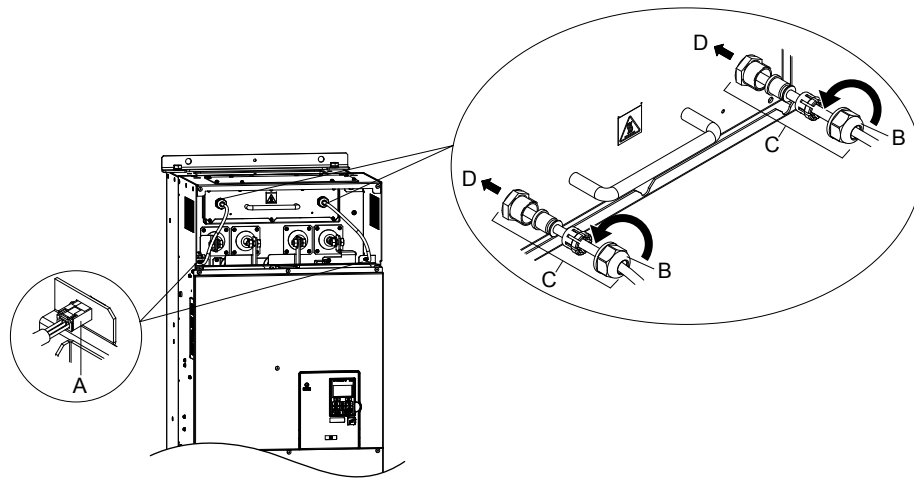

A – Relay connectors  
 B – Caps  
 C – Ground cables  
 D – Remove the fan cables

Figure 8.51 Remove the Relay Connector and Loosen the Cable Ground: 4A0302

3. Remove the screws holding the cooling fan unit in place and slide the fan unit out of the drive.

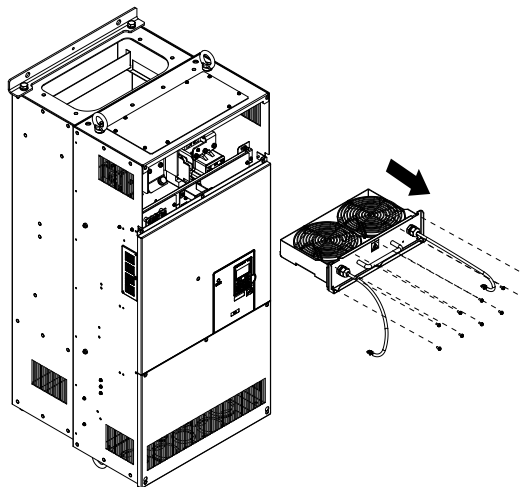
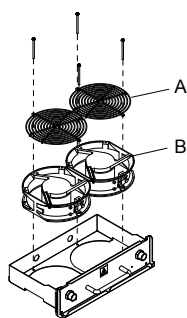

Figure 8.52 Remove the Cooling Fan Unit: 4A0302

4. Remove the fan guards and replace the cooling fans.



A – Fan guards

B – Cooling fans

Figure 8.53 Cooling Fan Disassembly: 4A0302

### ■ Installing the Cooling Fan Unit: 4A0302

1. Reverse the procedure to reinstall the cooling fan unit.

**Note:** Do not pinch the fan cable between parts when reassembling the fan unit.

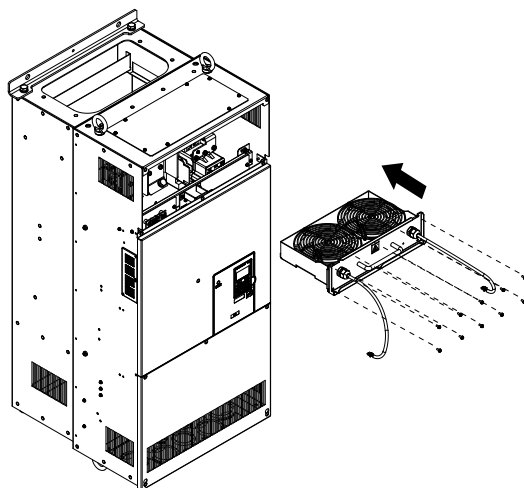

Figure 8.54 Insert the Cooling Fan Unit: 4A0302

2. Reattach the covers.
3. Turn on the power supply and set o4-03 to 0 to reset the Maintenance Monitor cooling fan operation time.

# Appendix: A

## Specifications

---

<b>A.1</b>	<b>POWER RATINGS.....</b>	<b>316</b>
<b>A.2</b>	<b>DRIVE SPECIFICATIONS.....</b>	<b>320</b>
<b>A.3</b>	<b>DRIVE WATT LOSS DATA.....</b>	<b>322</b>
<b>A.4</b>	<b>DRIVE DERATING DATA.....</b>	<b>324</b>
<b>A.5</b>	<b>BYPASS OPTIONS.....</b>	<b>325</b>

## A.1 Power Ratings

### ◆ Three-Phase 208 Vac Models Z1B1D002 to D046

Table A.1 Power Ratings (Three-Phase 208 V)

Item		Specification								
Bypass Model Z1B1		D002	D003	D004	D007	D010	D016	D024	D030	D046
Maximum Applicable Motor Capacity <1>	HP	0.5	0.75	1	2	3	5	7.5	10	15
	kW	0.37	0.55	0.74	1.5	2.2	3.7	5.5	7.5	11
Input	Input Current (A) <2>	2.9	4.0	5.1	8.0	11.1	17.2	24.7	31.3	46.7
	Rated Voltage Rated Frequency	Three-phase 208 Vac 50/60 Hz								
	Allowable Voltage Fluctuation	-15 to 10%								
	Allowable Frequency Fluctuation	±5%								
Output	Rated Output Current (A)	2.4 <3>	3.5 <3>	4.6 <3>	7.5 <3>	10.6 <3>	16.7 <3>	24.2 <3>	30.8 <3>	46.2 <3>
	Overload Tolerance	110% of rated output current for 60 s 150% peak								
	Carrier Frequency	User adjustable between 1 and 12.5 kHz (Maximum Frequency varies with Rated Output Capacity)								
	Maximum Output Voltage (V)	Three-phase 208 Vac								
	Maximum Output Frequency (Hz)	240 Hz								
Harmonics Reduction	DC Link Choke	Built-in								
EMC	Filter (IEC/EN 61800-3 Category 2)	Built-in								

- <1> The motor capacity (HP) refers to an NEC Table 430.250 208 V motor. The rated output current of the drive output amps should be equal to or greater than the motor current. Select the appropriate capacity drive if operating the motor continuously above motor nameplate current.
- <2> Assumes operation at the rated output current. Input current rating varies depending on the power supply transformer, input reactor, wiring connections, and power supply impedance.
- <3> Carrier frequency is set to 5 kHz. Current derating is required to raise the carrier frequency.

### ◆ Three-Phase 208 Vac Models Z1B1D059 to D273

Table A.2 Power Ratings Continued (Three-Phase 208 V)

Item		Specification							
Bypass Model Z1B1		D059	D074	D088	D114	D143	D169	D211	D273
Maximum Applicable Motor Capacity <1>	HP	20	25	30	40	50	60	75	100
	kW	14.7	18.4	22	29.4	36.8	44.1	55.2	73.6
Input	Input Current (A) <2>	59.9	75.5	88.7	114.7	144.4	170.4	212.4	274.4
	Rated Voltage Rated Frequency	Three-phase 208 Vac 50/60 Hz							
	Allowable Voltage Fluctuation	-15 to 10%							
	Allowable Frequency Fluctuation	±5%							
Output	Rated Output Current (A)	59.4 <3>	74.8 <3>	88.0 <3>	114.0 <3>	143.0 <3>	169.0 <3>	211.0 <3>	273.0 <3>
	Overload Tolerance	110% of rated output current for 60 s 150% peak							
	Carrier Frequency	User adjustable between 1 and 12.5 kHz (Maximum Frequency varies with Rated Output Capacity)							
	Maximum Output Voltage (V)	Three-phase 208 V							
	Maximum Output Frequency (Hz)	240 Hz							
Harmonics Reduction	DC Link Choke	Built-in							
EMC	Filter (IEC/EN 61800-3 Category 2)	Built-in							

<1> The motor capacity (HP) refers to an NEC Table 430.250 208 V motor. The rated output current of the drive output amps should be equal to or greater than the motor current. Select the appropriate capacity drive if operating the motor continuously above motor nameplate current.

<2> Assumes operation at the rated output current. Input current rating varies depending on the power supply transformer, input reactor, wiring connections, and power supply impedance.

<3> Carrier frequency is set to 5 kHz. Current derating is required to raise the carrier frequency.

### ◆ Three-Phase 480 Vac Models Z1B1B001 to B034

Table A.3 Power Ratings (Three-Phase 480 V)

Item		Specification									
Bypass Model Z1B1		B001	B002	B003	B004	B007	B011	B014	B021	B027	B034
Maximum Applicable Motor Capacity	HP <1>	0.75	1	2	3	5	7.5	10	15	20	25
	kW	0.55	0.74	1.5	2.2	3.7	5.5	7.5	11	14.7	18.4
Input	Input Current (A) <2>	1.8	2.3	3.6	5.0	7.8	11.2	14.2	21.2	27.2	34.2
	Rated Voltage Rated Frequency	Three-phase 480 Vac 50/60 Hz									
	Allowable Voltage Fluctuation	-15 to 10%									
	Allowable Frequency Fluctuation	±5%									
Output	Rated Output Current (A)	1.6 <3>	2.1 <3>	3.4 <3>	4.8 <3>	7.6 <3>	11.0 <3>	14.0 <3>	21.0 <3>	27.0 <3>	34.0 <3>
	Overload Tolerance	110% of rated output current for 60 s 150% peak									
	Carrier Frequency	User adjustable between 1 and 12.5 kHz (Maximum Frequency varies with Rated Output Capacity)									
	Maximum Output Voltage (V)	Three-phase 480 V									
	Maximum Output Frequency (Hz)	240 Hz									
Harmonics Reduction	DC Link Choke	Built-in									
EMC	Filter (IEC/EN 61800-3 Category 2)	Built-in									

<1> The motor capacity (HP) refers to an NEC Table 430.250 208 V motor. The rated output current of the drive output amps should be equal to or greater than the motor current. Select the appropriate capacity drive if operating the motor continuously above motor nameplate current.

<2> Assumes operation at the rated output current. Input current rating varies depending on the power supply transformer, input reactor, wiring connections, and power supply impedance.

<3> Carrier frequency is set to 5 kHz. Current derating is required to raise the carrier frequency.

## ◆ Three-Phase 480 Vac Models Z1B1B040 to B302

Table A.4 Power Ratings Continued (Three-Phase 480 V)

Item		Specification										
Bypass Model Z1B1		B040	B52L	B052	B065	B077	B096	B124	B156	B180	B240	B302
Maximum Applicable Motor Capacity	HP <1>	30	40	40	50	60	75	100	125	150	200	250
	kW	22	29.4	29.4	36.8	44.1	55.2	73.6	92	110.3	147.1	183.9
Input	Input Current (A) <2>	40.2	52.2	52.2	65.3	77.3	96.3	124.3	156.6	180.6	240.6	302.0
	Rated Voltage Rated Frequency	Three-phase 480 Vac 50/60 Hz										
	Allowable Voltage Fluctuation	-15 to 10%										
	Allowable Frequency Fluctuation	±5%										
Output	Rated Output Current (A)	40.0 <3>	52.0 <3>	52.0 <3>	65.0 <3>	77.0 <3>	96.0 <3>	124.0 <3>	156.0 <3>	180.0 <3>	240.0 <4>	302.0 <4>
	Overload Tolerance	110% of rated output current for 60 s 150% peak										
	Carrier Frequency	User adjustable between 1 and 12.5 kHz (Maximum Frequency varies with Rated Output Capacity)										
	Maximum Output Voltage (V)	Three-phase 480 V										
	Maximum Output Frequency (Hz)	240 Hz										
Harmonics Reduction	DC Link Choke	Built-in										
EMC	Filter (IEC/EN 61800-3 Category 2)	Built-in										

<1> The motor capacity (HP) refers to an NEC Table 430.250 208 V motor. The rated output current of the drive output amps should be equal to or greater than the motor current. Select the appropriate capacity drive if operating the motor continuously above motor nameplate current.

<2> Assumes operation at the rated output current. Input current rating varies depending on the power supply transformer, input reactor, wiring connections, and power supply impedance.

<3> Carrier frequency is set to 5 kHz. Current derating is required to raise the carrier frequency.

<4> Carrier frequency is set to 4 kHz. Current derating is required to raise the carrier frequency.

## A.2 Drive Specifications

- Note:**
1. Perform rotational Auto-Tuning to obtain the performance specifications given below.
  2. For optimum performance life of the drive, install the drive in an environment that meets the required specifications.

**Table A.5 Specifications**

	Item	Specification
Control Characteristics	Control Method	V/f Control (V/f)
	Frequency Control Range	0.01 to 240 Hz
	Frequency Accuracy (Temperature Fluctuation)	Digital input: within $\pm 0.01\%$ of the max output frequency (-10 to +50 °C) Analog input: within $\pm 0.1\%$ of the max output frequency (25 °C $\pm 10$ °C)
	Frequency Setting Resolution	Digital inputs: 0.01 Hz Analog inputs: 1/1000 of the maximum output frequency setting (10 bit unsigned)
	Output Frequency Resolution	0.001 Hz
	Frequency Setting Signal	0 to 10 V, 0 to 20 mA, 4 to 20 mA
	Starting Torque <1>	140% at 3 Hz
	Speed Control Range <2>	1:40
	Accel/Decel Time	0.0 to 6000.0 s (4 selectable combinations of independent acceleration and deceleration settings)
	Braking Torque	Approximately 20%
	V/f Characteristics	User-selected programs and V/f preset patterns possible
Protection Functions	Main Control Functions	Momentary Power Loss Ride-Thru, Speed Search, Overtorque/Undertorque Detection, 4 Step Speed (max), Accel/Decel Switch, S-curve Accel/decel, 3-Wire Sequence, Auto-Tuning (Stationary for Line-to-Line Resistance, Rotational for V/f Control), Cooling Fan on/off Switch, Slip Compensation, Torque Compensation, Frequency Jump, Upper/lower Limits for Frequency Reference, DC Injection Braking at Start and Stop, Overexcitation Braking, High Slip Braking, PI Control (with sleep function), Energy Saving Control, MEMOBUS/Modbus Comm. (RS-422/RS-485 max, 115.2 kbps), BACnet Comm. (RS-485 max, 115.2 kbps), Fault Restart, Application Presets, KEB, Overexcitation Deceleration, Overvoltage Suppression, Sequence Timer Operation, Secondary PI Control, Bypass Operation, HOA Keypad, Dynamic Noise Control
	Motor Protection	Electronic thermal overload relay
	Momentary Overcurrent Protection	Drive stops when rated output current exceeds 175%
	Overload Protection	Drive stops after 60 s at 110% of rated output current <2> Drive stops after 0.5 s at 140% of rated output current <2>
	Overvoltage Protection	208 V: Stops when DC bus voltage exceeds approx. 410 V 480 V: Stops when DC bus voltage exceeds approx. 820 V
	Undervoltage Protection	208 V: Stops when DC bus voltage falls below approx. 190 V 480 V: Stops when DC bus voltage falls below approx. 440 V
	Momentary Power Loss Ride-Thru	Immediately stop after 15 ms or longer power loss <3>
	Heatsink Overheat Protection	Thermistor
	Stall Prevention	Stall Prevention is available during acceleration, deceleration, and during run.
	Ground Protection	Electronic circuit protection <4> <5>
	DC Bus Charge LED	Remains lit until DC bus voltage falls below 50 V
Environment	Area of Use	Indoors
	Ambient Temperature	-10 °C to +40 °C NEMA Type 1 Enclosure
	Humidity	95% RH or less (no condensation)
	Storage Temperature	-20 °C to 70 °C (short-term temperature during transportation)
	Altitude	Up to 1000 meters without derating, up to 3000 m with output current and voltage derating. <i>Refer to Altitude Derating on page 324</i> for details.
	Vibration/Shock	10 to 20 Hz at 9.8 m/s <sup>2</sup> 20 to 55 Hz at 5.9 m/s <sup>2</sup> (Drive models CIMR-Z□2A0011 to 2A0031 and 4A0005 to 4A0027) or 2.0 m/s <sup>2</sup> (Drive Models CIMR-Z□2A0046 to 2A0396 and 4A0034 to 4A0590)
Safety Standard		IEC/EN 61800-5-1
Protection Design		NEMA Type 1 enclosure

<1> The accuracy of these values depends on motor characteristics, ambient conditions, and drive settings. Specifications may vary with different motors and with changing motor temperature. Contact Yaskawa for consultation.

<2> Overload protection may be triggered when operating with 100% of the rated output current if the output frequency is less than 6 Hz.

<3> May be shorter due to load conditions and motor speed.



- <4> Ground protection cannot be provided when the impedance of the ground fault path is too low, or when the drive is powered up while a ground fault is present at the output.
- <5> Setting L8-09 to 1 enables ground fault detection in models Z1B1D064 to D273 and B052 to B302.

## A.3 Drive Watt Loss Data

Table A.6 Watt Loss 200 V Class Three-Phase Models

Model	Rated Amps (A)	Heatsink Loss (W)	Interior Unit Loss (W)	Total Loss (W)
2A0011	10.6 <1>	121	28	148
2A0017	16.7 <1>	176	37	214
2A0024	24.2 <1>	280	55	335
2A0031	30.8 <1>	378	73	451
2A0046	46.2 <1>	396	86	482
2A0059	59.4 <1>	542	116	658
2A0075	74.8 <1>	557	132	688
2A0088	88 <1>	670	157	827
2A0114	114 <1>	864	200	1064
2A0143	143 <1>	1191	307	1499
2A0169	169 <1>	1447	365	1811
2A0211	211 <1>	1753	471	2224
2A0273	273 <1>	2378	625	3003
2A0343	343 <2>	1964	655	2620
2A0396	396 <2>	2435	829	3264

<1> Value assumes the carrier frequency is set to 5 kHz or less.

<2> Value assumes the carrier frequency is set to 2 kHz.

Table A.7 Watt Loss 400 V Class Three-Phase Models

Model	Rated Amps (A)	Heatsink Loss (W)	Interior Unit Loss (W)	Total Loss (W)
4A0005	4.8 <1>	93	24	117
4A0008	7.6 <1>	146	33	178
4A0011	11 <1>	184	38	222
4A0014	14 <1>	231	52	283
4A0021	21 <1>	306	69	375
4A0027	27 <1>	390	85	475
4A0034	34 <1>	457	105	562
4A0040	40 <1>	558	118	677
4A0052□□B	52 <1>	584	151	734
4A0052□□A	52 <1>	463	130	594
4A0065	65 <1>	576	161	737
4A0077	77 <1>	891	225	1116
4A0096	96 <1>	1131	288	1419
4A0124	124 <1>	1581	398	1979
4A0156	156 <1>	1929	535	2464
4A0180	180 <1>	2342	621	2963
4A0240	240 <2>	2863	790	3653
4A0302	302 <2>	3278	929	4207
4A0361	361 <3>	3009	1157	4166
4A0414	414 <3>	3206	1633	4840
4A0480	480 <3>	3881	2011	5893
4A0590	590 <3>	4130	1964	6094

<1> Value assumes the carrier frequency is set to 5 kHz or less.

<2> Value assumes the carrier frequency is set to 4 kHz or less.

<3> Value assumes the carrier frequency is set to 2 kHz.

## A.4 Drive Derating Data

The drive can be operated at above the rated temperature, altitude, and default carrier frequency by derating the drive capacity.

### ◆ Carrier Frequency Derating

Derate the drive according to [Figure A.1](#) to [Figure A.3](#) as the carrier frequency increases above the factory default setting.

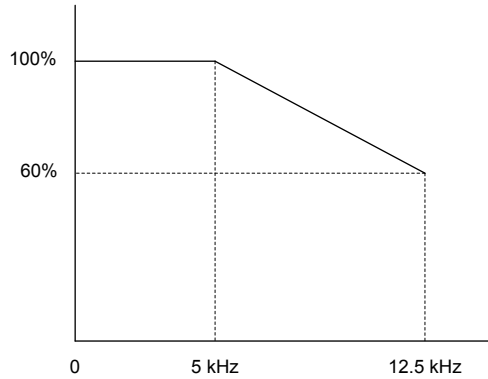

Figure A.1 Carrier Frequency Derating (Z1B1D002 to D114 and B001 to B096)

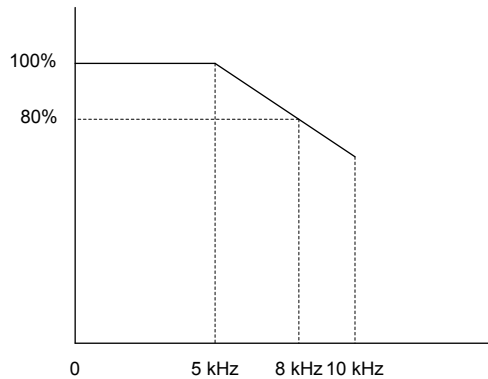

Figure A.2 Carrier Frequency Derating (Z1B1D143 to D173 and B124 to B180)

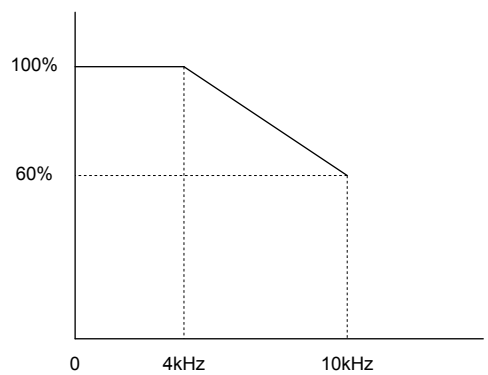

Figure A.3 Carrier Frequency Derating (Z1B1B240 and B302)

### ◆ Altitude Derating

The drive standard ratings are valid for installation altitudes up to 1000 m. For installations from 1000 m to 3000 m, the drive rated output current must be derated for 0.2% per 100 m.

## A.5 Bypass Options

The following configurations are available for the Z1000 Bypass.

---

### ◆ Option B

Three-contactor bypass: Isolates the drive circuit by adding a separate drive input contactor.

---

### ◆ Option D

Ethernet/IP option.

---

### ◆ Option M

Motor Circuit Protector (MCP)/Disconnect: Replaces the standard input disconnect switch and provides short circuit protection integral with the drive and bypass package. The MCP includes a feature to padlock the operator mechanism through the door. Without this option, short circuit protection must be provided by others on the input side of the drive and bypass.

---

### ◆ Option G

Drive Input Disconnect Switch: Provides a disconnect means for the input side of the Drive, for Drive isolation capability during bypass operation. This disconnect is located inside the enclosure with an integral operating handle.

---

### ◆ Option L

Serial Communication, Echelon LonWorks: An isolated circuit board provides LonTalk protocol for network communication to a BAS. This option plugs into the CN5 connection on the bypass control circuit board.

---

### ◆ Option W

Custom Nameplate: Provides a custom nameplate for placement on the front of the Z1000 Bypass.

**This Page Intentionally Blank**

# Appendix: B

## Parameter List

---

This appendix contains a full listing of all parameters and settings available in the drive.

<b>B.1</b>	<b>PARAMETER GROUPS.....</b>	<b>328</b>
<b>B.2</b>	<b>A: INITIALIZATION PARAMETERS.....</b>	<b>329</b>
<b>B.3</b>	<b>B: APPLICATION.....</b>	<b>330</b>
<b>B.4</b>	<b>C: TUNING.....</b>	<b>334</b>
<b>B.5</b>	<b>D: REFERENCES.....</b>	<b>335</b>
<b>B.6</b>	<b>E: MOTOR PARAMETERS.....</b>	<b>337</b>
<b>B.7</b>	<b>F: OPTIONS.....</b>	<b>338</b>
<b>B.8</b>	<b>H PARAMETERS: MULTI-FUNCTION TERMINALS.....</b>	<b>339</b>
<b>B.9</b>	<b>L: PROTECTION FUNCTION.....</b>	<b>344</b>
<b>B.10</b>	<b>N: SPECIAL ADJUSTMENT.....</b>	<b>347</b>
<b>B.11</b>	<b>O: OPERATOR-RELATED SETTINGS.....</b>	<b>348</b>
<b>B.12</b>	<b>S: SPECIAL APPLICATION.....</b>	<b>350</b>
<b>B.13</b>	<b>U: MONITORS.....</b>	<b>354</b>
<b>B.14</b>	<b>Z: BYPASS PARAMETERS.....</b>	<b>363</b>
<b>B.15</b>	<b>DEFAULTS BY DRIVE MODEL.....</b>	<b>372</b>

## B.1 Parameter Groups

Table B.1 Parameter Groups

Parameter Group	Name	Page	Parameter Group	Name	Page
A1	Initialization Parameters	329	L4	Speed Detection	345
b1	Operation Mode Selection	330	L5	Fault Restart	345
b2	DC Injection Braking and Short Circuit Braking	330	L6	Torque Detection	346
b3	Speed Search	330	L8	Drive Protection	346
b5	PI Control	331	n1	Hunting Prevention	347
C1	Acceleration and Deceleration Times	334	n3	High Slip Braking (HSB) and Overexcitation Braking	347
C2	S-Curve Characteristics	334	o1	HOA Keypad Display Selection	348
C4	Torque Compensation	334	o2	HOA Keypad Functions	348
C6	Carrier Frequency	334	o4	Maintenance Monitor Settings	349
d1	Frequency Reference	335	S1	Dynamic Noise Control Function	350
d2	Frequency Upper/Lower Limits	335	S2	Sequence Timer Operation	350
d3	Jump Frequency	335	T1	Induction Motor Auto-Tuning	352
E1	V/f Pattern for Motor 1	337	UB	Bypass Control Monitors	354
E2	Motor 1 Parameters	337	U1	Operation Status Monitors	355
F6	Drive/Bypass Communications	338	U2	Fault Trace	357
H1	Multi-Function Digital Inputs	339	U3	Fault History	358
H2 <1>	Multi-Function Digital Outputs	340	U4	Maintenance Monitors	360
H3	Multi-Function Analog Inputs	341	U5	PI Monitors	361
H4	Multi-Function Analog Outputs	165	Z1	Bypass Control System	363
H5 <2>	MEMOBUS/Modbus Serial Communication	343	Z2	Bypass Control Input/Output	367
L1	Motor Protection	344	Z3	Bypass Control Communication	368
L2	Momentary Power Loss Ride-Thru	344	Z4	Bypass Control Option Boards	370
L3	Stall Prevention	344			

<1> Available in bypass controller software versions VST800298 and later.

<2> Available in bypass controller software versions VST800297 and earlier.

Table B.2 Symbols and Icons Used in Parameter Descriptions

Symbol	Description
	Parameter can be changed during run.



## B.2 A: Initialization Parameters

### ◆ A1: Initialization

No. (Addr. Hex)	Name	Description	Values	Page
A1-06 (127)	Application Preset Application Sel	0: Standard 0: General 1: Fan 1: Fan General 2: Fan with PI Control 2: Fan PI 3: Return Fan with PI Control 3: Fan ReturnAir/PI 4: Cooling Tower Fan 4: Cooling Tower 5: Cooling Tower Fan with PI Control 5: CoolingTower/PI 6: Pump (Secondary) 6: Pump Secondary 7: Pump with PI Control 7: Pump PI	Default: 0 Range: 0 to 7	<i>118</i>

## B.3 b: Application

Application parameters configure the source of the Run command, DC Injection Braking, Speed Search, timer functions, PI control, Energy Savings, and a variety of other application-related settings.

### ◆ b1: Operation Mode Selection

No. (Addr. Hex)	Name	Description	Values	Page
b1-03 (182)	Stopping Method Selection Stopping Method	0: Ramp to stop 0: Ramp to Stop 1: Coast to stop 1: Coast to Stop 2: DC Injection Braking to stop 2: DCInj to Stop 3: Coast with timer 3: Coast w/Timer	Default: 1 Range: 0 to 3	119
b1-04 (183)	Reverse Operation Selection Reverse Oper	0: Reverse enabled 0: Reverse Enabled 1: Reverse disabled 1: Reverse Disabled	Default: 1 Range: 0, 1	121

### ◆ b2: DC Injection Braking and Short Circuit Braking

No. (Addr. Hex)	Name	Description	Values	Page
b2-01 (189)	DC Injection Braking Start Frequency DCInj Start Freq	Sets the frequency at which DC Injection Braking starts when “Ramp to stop” (b1-03 = 0) is selected.	Default: 0.5 Hz Min.: 0.0 Max.: 10.0	121
b2-02 (18A)	DC Injection Braking Current DCInj Current	Sets the DC Injection Braking current as a percentage of the drive rated current.	Default: 50% Min.: 0 Max.: 100	121
b2-03 (18B)	DC Injection Braking Time at Start DCInj Time@Start	Sets DC Injection Braking time at start. Disabled when set to 0.00 seconds.	Default: 0.00 s Min.: 0.00 Max.: 10.00	122
b2-04 (18C)	DC Injection Braking Time at Stop DCInj Time@Stop	Sets DC Injection Braking time at stop.	Default: 0.00 s Min.: 0.00 Max.: 10.00	122

### ◆ b3: Speed Search

No. (Addr. Hex.)	Name	Description	Values	Page
b3-01 (191)	Speed Search Selection at Start SpdSrch at Start	0: Disabled 0: Disabled 1: Enabled 1: Enabled	Default: 0 Range: 0, 1	125
b3-02 (192)	Speed Search Deactivation Current SpdSrch DeactCur	Sets the current level at which the speed is assumed to be detected and Speed Search is ended. Set as a percentage of the drive rated current.	Default: 120% Min.: 0 Max.: 200	125
b3-03 (193)	Speed Search Deceleration Time SpdSrch Dec Time	Sets output frequency reduction time during Speed Search.	Default: 2.0 s Min.: 0.1 Max.: 10.0	125
b3-04 (194)	V/f Gain during Speed Search SpdSrch V/f	Determines how much to lower the V/f ratio during Speed Search. Output voltage during Speed Search equals the V/f setting multiplied by b3-04.	Default: <V> Min.: 10% Max.: 100%	125
b3-05 (195)	Speed Search Delay Time Search Delay	When using an external contactor on the output side, b3-05 delays executing Speed Search after a momentary power loss to allow time for the contactor to close.	Default: 0.2 s Min.: 0.0 Max.: 100.0	125
b3-06 (196)	Output Current 1 during Speed Search Srch Im Lvl1	Sets the current injected to the motor at the beginning of Speed Estimation Speed Search. Set as a coefficient for the motor rated current.	Default: <V> Min.: 0.0 Max.: 2.0	125
b3-07 (197)	Output Current 2 during Speed Search (Speed Estimation Type) Srch Im Lvl2	Sets the amount of output current during Speed Estimation Speed Search as a coefficient for the no-load current (output current during Speed Search is automatically limited by the drive rated current). Increase this setting value in increments of 0.1 if the drive fails to perform Speed Estimation.	Default: 1.0 Min.: 0.0 Max.: 5.0	126

No. (Addr Hex.)	Name	Description	Values	Page
b3-08 (198)	Current Control Gain during Speed Search (Speed Estimation Type) Srch ACR P Gain	Sets the proportional gain for the current controller during Speed Search.	Default: <I> Min.: 0.00 Max.: 6.00	126
b3-09 (199)	Current Control Integral Time during Speed Search (Speed Estimation Type) Srch ACR I Time	Sets the Integral Time for the current controller during Speed Search.	Default: 2.0 ms Min.: 0.0 Max.: 1000.0	126
b3-10 (19A)	Speed Search Detection Compensation Gain Srch Detect Comp	Sets the gain which is applied to the speed detected by Speed Estimation Speed Search before the motor is reaccelerated. Increase this setting if ov occurs when performing Speed Search after a relatively long period of baseblock.	Default: 1.05 Min.: 1.00 Max.: 1.20	126
b3-11 (19B)	Speed Search Method Switching Level (Speed Estimation Type) Srch Mthd Sw Lvl	Uses the amount of voltage remaining in the motor to automatically switch the search method within the type of speed measurement. (208 Vac at 100% = 208 V, and 480 Vac at 100% = 480 V)	Default: 5.0% Min.: 0.5 Max.: 100.0	126
b3-12 (19C)	Minimum Current Detection Level during Speed Search Srch I Deadband	Sets the minimum current detection level during Speed Search. Increase this setting value in increments of 0.1 if the drive fails to perform Speed Estimation.	Default: <I> Min.: 2.0 Max.: 10.0	126
b3-14 (19E)	Bi-Directional Speed Search Selection Bidir Search Sel	0: Disabled 0: Disabled (uses the direction of the frequency reference) 1: Enabled 1: Enabled (drive detects which way the motor is rotating)	Default: 1 Range: 0, 1	126
b3-17 (1F0)	Speed Search Restart Current Level SrchRestart Lvl	Sets the Speed Search restart current level as a percentage of the drive rated current.	Default: 110% Min.: 0 Max.: 200	127
b3-18 (1F1)	Speed Search Restart Detection Time SrchRestart Time	Sets the time to detect Speed Search restart.	Default: 0.10 s Min.: 0.00 Max.: 1.00	127
b3-19 (1F2)	Number of Speed Search Restarts Num of SrchRestr	Sets the number of times the drive can attempt to restart when performing Speed Search.	Default: 3 Min.: 0 Max.: 10	127
b3-24 (1C0)	Speed Search Method Selection SpdSrch Method	0: Current Detection 0: CurrentDetection 1: Speed Estimation 1: Speed Estimation	Default: 0 Range: 0, 1	127
b3-25 (1C8)	Speed Search Wait Time SpdSrch WaitTime	Sets the time the drive must wait between each Speed Search restart attempt.	Default: 0.5 s Min.: 0.0 Max.: 30.0	127
b3-27 (1C9)	Start Speed Search Select Start srch sel	Selects a condition to activate Speed Search Selection at Start (b3-01) or External Speed Search Command 1 or 2 from the multi-function input. 0: Triggered when a Run command is issued. 0: start from 0 (normal). 1: Triggered when an external baseblock is released. 1: Start Fref>Fmin	Default: 0 Range: 0, 1	127

<I> Default setting is dependent on parameter o2-04, Drive Model Selection.

## ◆ b5: PI Control

No. (Addr. Hex.)	Name	Description	Values	Page
b5-01 (1A5)	PI Function Setting PI Mode	0: Disabled 0: Disabled 1: Enabled 1: Enabled D=Fdbk (PI output becomes output frequency reference) 3: Enabled 3: Fref+PID D=Fdbk (PI output added to frequency reference)	Default: 0 Range: 0, 1, 3	131
b5-02 (1A6) [RUN]	Proportional Gain Setting (P) PI Gain	Sets the proportional gain of the PI controller.	Default: 2.00 Min.: 0.00 Max.: 25.00	131
b5-03 (1A7) [RUN]	Integral Time Setting (I) PI I Time	Sets the integral time for the PI controller.	Default: 0.5 s Min.: 0.0 Max.: 360.0	131
b5-04 (1A8) [RUN]	Integral Limit Setting PI I Limit	Sets the maximum output possible from the integrator as a percentage of the maximum output frequency.	Default: 100.0% Min.: 0.0 Max.: 100.0	131

## B.3 b: Application

No. (Addr. Hex)	Name	Description	Values	Page
b5-06 (1AA) 	PI Output Limit PI Limit	Sets the maximum output possible from the entire PI controller as a percentage of the maximum output frequency.	Default: 100.0% Min.: 0.0 Max.: 100.0	<a href="#">131</a>
b5-07 (1AB) 	PI Offset Adjustment PI Offset	Applies an offset to the PI controller output. Set as a percentage of the maximum output frequency.	Default: 0.0% Min.: -100.0 Max.: 100.0	<a href="#">131</a>
b5-08 (1AC) 	PI Primary Delay Time Constant PI Delay Time	Sets a low pass filter time constant on the output of the PI controller.	Default: 0.00 s Min.: 0.00 Max.: 10.00	<a href="#">131</a>
b5-09 (1AD)	PI Output Level Selection Output Level Sel	0: Normal output 0: Normal Character (direct acting) 1: Reverse output 1: Rev Character (reverse acting)	Default: 0 Range: 0, 1	<a href="#">132</a>
b5-10 (1AE)	PI Output Gain Setting Output Gain	Sets the gain applied to the PI output.	Default: 1.00 Min.: 0.00 Max.: 25.00	<a href="#">132</a>
b5-11 (1AF)	PI Output Reverse Selection Output Rev Sel	0: Negative PI output triggers zero limit. 0: limit 1: Rotation direction reverses with negative PI output. 1: Reverse <b>Note:</b> When using setting 1, make sure reverse operation is permitted by b1-04.	Default: 0 Range: 0, 1	<a href="#">132</a>
b5-12 (1B0)	PI Feedback Loss Detection Selection Fb loss Det Sel	0: No fault. Digital output only. 0: DO Only - Always 1: Fault detection. Alarm output, drive continues operation. 1: Alarm - Always 2: Fault detection. Fault output, drive output is shut off. 2: Fault - Always 3: Digital Output Always 3: DO Only@PI Enbl 4: Feedback Loss Alarm 4: Alarm @ PI Enbl 5: Feedback Loss Fault 5: Fault @ PI Enbl	Default: 0 Range: 0 to 5	<a href="#">133</a>
b5-13 (1B1)	PI Feedback Loss Detection Level Fb loss Det Lvl	Sets the PI feedback loss detection level as a percentage of the maximum output frequency.	Default: 0% Min.: 0 Max.: 100	<a href="#">133</a>
b5-14 (1B2)	PI Feedback Loss Detection Time Fb loss Det Time	Sets a delay time for PI feedback loss.	Default: 1.0 s Min.: 0.0 Max.: 25.5	<a href="#">134</a>
b5-15 (1B3)	PI Sleep Function Start Level PI Sleep Level	Sets the frequency level that triggers the sleep/snooze function.	Default: 0.0 Hz Min.: 0.0 Max.: 240.0	<a href="#">135</a>
b5-16 (1B4)	PI Sleep Delay Time PI Sleep Time	Sets a delay time before the sleep/snooze function is triggered.	Default: 0.0 s Min.: 0.0 Max.: 25.5	<a href="#">135</a>
b5-17 (1B5)	PI Accel/Decel Time PI Acc/Dec Time	Sets the acceleration and deceleration time to PI setpoint.	Default: 0.0 s Min.: 0.0 Max.: 6000.0	<a href="#">135</a>
b5-18 (1DC)	PI Setpoint Selection PI Setpoint Sel	0: Disabled 0: Disabled 1: Enabled 1: Enabled	Default: 0 Range: 0, 1	<a href="#">135</a>
b5-19 (1DD)	PI Setpoint Value PI Setpoint	Sets the PI target value when b5-18 = 1. Set as a percentage of the maximum output frequency.	Default: 0.00% Min.: 0.00 Max.: 100.00	<a href="#">135</a>
b5-20 (1E2)	PI Setpoint Scaling PI Disp Scaling	0: 0.01 Hz units 0: 0.01Hz units 1: 0.01% units 1: 0.01% units (100% = max output frequency) 2: r/min 2: r/min (number of motor poles must entered) 3: User-set 3: User Units (set scaling to b5-38 and b5-39)	Default: 1 Range: 0 to 3	<a href="#">135</a>
b5-34 (19F) 	PI Output Lower Limit PI Out Low Lim	Sets the minimum output possible from the PI controller as a percentage of the maximum output frequency.	Default: 0.0% Min.: -100.0 Max.: 100.0	<a href="#">136</a>
b5-35 (1A0) 	PI Input Limit PI Input Limit	Limits the PI control input (deviation signal) as a percentage of the maximum output frequency. Acts as a bipolar limit.	Default: 1000.0% Min.: 0.0 Max.: 1000.0	<a href="#">136</a>
b5-36 (1A1)	PI Feedback High Detection Level Fb High Det Lvl	Sets the PI feedback high detection level as a percentage of the maximum output frequency.	Default: 100% Min.: 0 Max.: 100	<a href="#">134</a>

No. (Addr. Hex)	Name	Description	Values	Page
b5-37 (1A2)	PI Feedback High Detection Time Fb High Dly Time	Sets the PI feedback high level detection delay time.	Default: 1.0 s Min.: 0.0 Max.: 25.5	134
b5-38 (1FE)	PI Setpoint User Display PI UsrDspMaxVal	Sets the display value of U5-01 and U5-04 when the maximum frequency is output.	Default: <1> Min.: 1 Max.: 60000	136
b5-39 (1FF)	PI Setpoint Display Digits PI UsrDspDigits	0: No decimal places 0: No Dec (XXXXX) 1: One decimal place 1: 1 Dec (XXXX.X) 2: Two decimal places 2: 2 Dec (XXX.XX) 3: Three decimal places 3: 3 Dec (XX.XXX)	Default: <1> Range: 0 to 3	136
b5-40 (17F)	Frequency Reference Monitor Content during PI Fref Mon Sel@PI	0: Display the frequency reference (U1-01) after PI compensation has been added. 0: After PI 1: Display the frequency reference (U1-01) before PI compensation has been added. 1: Before PI	Default: 0 Range: 0, 1	136
b5-46 (165)	PI Setpoint Monitor Unit Selection PI Mon Unit Sel	0: "WC" 0: "WC(Inch of water) 1: PSI 1: PSI(Pounds per square inch) 2: GPM 2: GPM(Gallons per minute) 3: F 3: °F (Degrees Fahrenheit) 4: CFM 4: CFM(Cubic feet per minute) 5: CMH 5: CMH(Cubic meters per hour) 6: LPH 6: LPH(Liters per hour) 7: LPS 7: LPS(Liters per second) 8: Bar 8: Bar(Bar) 9: Pa 9: Pa(Pascal) 10: C 10: °C (Degrees Celsius) 11: Mtr 11: Mtr(Meters) 12: Ft 12: Ft(Feet) 13: LPM 13: LPM(Liters per minute) 14: CMM 14: CMM(Cubic meters per minute)	Default: 0 Range: 0 to 14	136
b5-47 (17D)	Reverse Operation Selection 2 by PI Output Output Rev Sel2	Reverse operation selection when b5-01 = 3 0: Reverse Disabled 0: 0 limit 1: Reverse Enabled 1: Reverse	Default: 1 Range: 0, 1	137

<1> Default setting is dependent on parameter b5-20, PI Setpoint Scaling.

## B.4 C: Tuning

C parameters are used to adjust the acceleration and deceleration times and carrier frequency selections.

### ◆ C1: Acceleration and Deceleration Times

No. (Addr. Hex)	Name	Description	Values	Page
C1-01 (200) RUN	Acceleration Time 1 Accel Time 1	Sets the time to accelerate from 0 to maximum frequency.	Default: 30.0 s Min.: 0.1 Max.: 6000.0	139
C1-02 (201) RUN	Deceleration Time 1 Decel Time 1	Sets the time to decelerate from maximum frequency to 0.		139
C1-09 (208)	Fast Stop Time Fast Stop Time	Sets the time for the Fast Stop function.	Default: 10.0 s Min.: 0.1 Max.: 6000.0	139

### ◆ C2: S-Curve Characteristics

No. (Addr. Hex)	Name	Description	Values	Page
C2-01 (20B)	S-Curve Characteristic at Accel Start SCrv Acc @ Start	The S-curve can be controlled at the four points shown below. 	Default: 0.20 s Min.: 0.00 Max.: 10.00	139
C2-02 (20C)	S-Curve Characteristic at Accel End SCrv Acc @ End		Default: 0.20 s Min.: 0.00 Max.: 10.00	139

<1> S-curve characteristics at decel start/end are fixed to 0.20 s.

### ◆ C4: Torque Compensation

No. (Addr. Hex)	Name	Description	Values	Page
C4-01 (215) RUN	Torque Compensation Gain Torq Comp Gain	Sets the gain for the automatic torque (voltage) boost function and helps to produce better starting torque. Used for motor 1.	Default: 1.00 Min.: 0.00 Max.: 2.50	140

### ◆ C6: Carrier Frequency

No. (Addr. Hex)	Name	Description	Values	Page
C6-02 (224)	Carrier Frequency Selection CarrierFreq Sel	1: 2.0 kHz 1: Fc=2.0kHz 2: 5.0 kHz 2: Fc=5.0 kHz 3: 8.0 kHz 3: Fc=8.0 kHz 4: 10.0 kHz 4: Fc=10.0 kHz 5: 12.5 kHz 5: Fc=12.5 kHz 7: Swing PWM1 7: Swing PWM1 (Audible sound 1) 8: Swing PWM2 8: Swing PWM2 (Audible sound 2) 9: Swing PWM3 9: Swing PWM3 (Audible sound 3) A: Swing PWM4 A: Swing PWM4 (Audible sound 4)	Default: <1> Range: 1 to 5; 7 to A	140
C6-05 (227)	Carrier Frequency Proportional Gain CarrierFreq Gain	Determines the proportional gain for the carrier frequency.	Default: <2> Min.: 0 Max.: 99	141

<1> Default setting value is dependent on parameter o2-04, Drive Model Selection.

<2> Default setting value is dependent on parameter C6-02, Carrier Frequency Selection.

## B.5 d: References

Reference parameters set the various frequency reference values during operation.

### ◆ d1: Frequency Reference

No. (Addr. Hex)	Name	Description	Values	Page
d1-01 (280) <input type="checkbox"/> RUN	Frequency Reference 1 Reference 1	Sets the frequency reference for the drive. Setting units are determined by parameter o1-03.	Default: 0.00 Hz Min.: 0.00 Max.: 240.00 <I>	142
d1-02 (281) <input type="checkbox"/> RUN	Frequency Reference 2 Reference 2	Sets the frequency reference for the drive. Setting units are determined by parameter o1-03.	Default: 0.00 Hz Min.: 0.00 Max.: 240.00 <I>	142
d1-03 (282) <input type="checkbox"/> RUN	Frequency Reference 3 Reference 3	Sets the frequency reference for the drive. Setting units are determined by parameter o1-03.	Default: 0.00 Hz Min.: 0.00 Max.: 240.00 <I>	142
d1-04 (283) <input type="checkbox"/> RUN	Frequency Reference 4 Reference 4	Sets the frequency reference for the drive. Setting units are determined by parameter o1-03.	Default: 0.00 Hz Min.: 0.00 Max.: 240.00 <I>	142

<I> Range upper limit is determined by parameter E1-04, Maximum Output Frequency.

### ◆ d2: Frequency Upper/Lower Limits

No. (Addr. Hex.)	Name	Description	Setting	Page
d2-01 (289)	Frequency Reference Upper Limit Ref Upper Limit	Sets the frequency reference upper limit as a percentage of the maximum output frequency.	Default: 100.0% Min.: 0.0 Max.: 110.0	143
d2-02 (28A)	Frequency Reference Lower Limit Ref Lower Limit	Sets the frequency reference lower limit as a percentage of the maximum output frequency.	Default: 0.0% Min.: 0.0 Max.: 110.0	143
d2-03 (293)	Master Speed Reference Lower Limit Ref1 Lower Limit	Sets the lower limit for frequency references from analog inputs as a percentage of the maximum output frequency.	Default: 0.0% Min.: 0.0 Max.: 110.0	143

### ◆ d3: Jump Frequency

No. (Addr. Hex)	Name	LCD Display	Description	Values	Page
d3-01 (294)	Jump Frequency 1	Jump Freq 1	Eliminates problems with resonant vibration of the motor/machine by avoiding continuous operation in predefined frequency ranges. The drive accelerates and decelerates the motor through the prohibited frequency ranges. Setting 0.0 disables this function. Parameters must be set so that $d3-01 \geq d3-02 \geq d3-03$ .	Default: 0.0 Hz Min.: 0.0 Max.: 240.0	144
d3-02 (295)	Jump Frequency 2	Jump Freq 2	Eliminates problems with resonant vibration of the motor/machine by avoiding continuous operation in predefined frequency ranges. The drive accelerates and decelerates the motor through the prohibited frequency ranges. Setting 0.0 disables this function. Parameters must be set so that $d3-01 \geq d3-02 \geq d3-03$ .	Default: 0.0 Hz Min.: 0.0 Max.: 240.0	144
d3-03 (296)	Jump Frequency 3	Jump Freq 3	Eliminates problems with resonant vibration of the motor/machine by avoiding continuous operation in predefined frequency ranges. The drive accelerates and decelerates the motor through the prohibited frequency ranges. Setting 0.0 disables this function. Parameters must be set so that $d3-01 \geq d3-02 \geq d3-03$ .	Default: 0.0 Hz Min.: 0.0 Max.: 240.0	144

## B.5 d: References

---

No. (Addr. Hex)	Name	LCD Display	Description	Values	Page
d3-04 (297)	Jump Frequency Width	Jump Bandwidth	Sets the dead-band width around each selected prohibited frequency reference point.	Default: 1.0 Hz Min.: 0.0 Max.: 20.0	<i>144</i>



## B.6 E: Motor Parameters

### ◆ E1: V/f Pattern for Motor 1

No. (Addr. Hex)	Name	Description	Values	Page
E1-01 (300)	Input Voltage Setting Input Voltage	This parameter must be set to the power supply voltage.  <b>WARNING! Electrical Shock Hazard. Drive input voltage (not motor voltage) must be set in E1-01 for the protective features of the drive to function properly. Failure to do so may result in equipment damage and/or death or personal injury.</b>	Default: 230 V <1> Min.: 190 Max.: 240 <1>	145
E1-03 (302)	V/f Pattern Selection V/F Selection	0: 50 Hz, Constant torque 1 0: 50 Hz 1: 60 Hz, Constant torque 2 1: 60 Hz Saturation 2: 50 Hz, Constant torque 3 (50 Hz base) 2: 50 Hz Saturation 3: 72 Hz, Constant torque 4 (60 Hz base) 3: 72 Hz 4: 50 Hz, Variable torque 1 4: 50 Hz VT1 5: 50 Hz, Variable torque 2 5: 50 Hz VT2 6: 60 Hz, Variable torque 3 6: 60 Hz VT1 7: 60 Hz, Variable torque 4 7: 60 Hz VT2 8: 50 Hz, High starting torque 1 8: 50 Hz HST1 9: 50 Hz, High starting torque 2 9: 50 Hz HST2 A: 60 Hz, High starting torque 3 A: 60 Hz HST1 B: 60 Hz, High starting torque 4 B: 60 Hz HST2 C: 90 Hz (60 Hz base) C: 90 Hz D: 120 Hz (60 Hz base) D: 120 Hz E: 180 Hz (60 Hz base) E: 180 Hz F: Custom V/f F: Custom V/F E1-05 setting defines the V/f pattern	Default: F <2> Range: 0 to 9; A to F	145
E1-05 (304)	Maximum Voltage Max Voltage	Only applicable when E1-03 is set to F.	Default: <3> Min.: 0.0 V Max.: 255.0 V <1>	148

<1> Values shown are specific to 208 Vac. Double the value for 480 Vac.

<2> Parameter setting value is not reset to the default value when the drive is initialized.

<3> Default setting is dependent on parameter o2-04, Drive Model Selection.

### ◆ E2: Motor Parameters

No. (Addr. Hex)	Name	Description	Values	Page
E2-01 (030E)	Motor Rated Current Motor Rated FLA	Sets the motor nameplate full load current in amps. Automatically set during Auto-Tuning.	Default: <1> Min.: 10% of drive rated current Max.: 200% of drive rated current <2>	149
E2-03 (310)	Motor No-Load Current No-Load Current	Sets the no-load current for the motor. Automatically set during Auto-Tuning.	Default: <1> Min.: 0 A Max.: E2-01 <2>	149

<1> Default setting is dependent on parameter o2-04, Drive Model Selection.

<2> The number of decimal places in the parameter value depends on the drive model. *Refer to Defaults by Drive Model on page 372* for details.

## B.7 F: Options

F parameters control the communication between the drive and the bypass.

### ◆ F6: Drive/Bypass Communications

No. (Addr. Hex)	Name	Description	Values	Page
F6-01 (03A2)	Communication Error Operation Selection	Selects the drive behavior when the drive detects a CE fault. 0: Ramp to Stop. Decelerate to stop using the deceleration time in C1-02. 1: Coast to Stop. 2: Fast-Stop. Decelerate to stop using the deceleration time in C1-09. 3: Alarm only. 4: Alarm (d1-04)	Default: 1 Range: 0 to 4	<i>150</i>
F6-02 (03A3)	External Fault from Bypass Controller Detection Selection EF0 Detection	Selects when the drive should detect an EF0 fault issued by the bypass controller. 0: Always detected 1: Only during run	Default: 0 Range: 0, 1	<i>150</i>
F6-03 (03A4)	External Fault from Bypass Controller Operation Selection EF0 Action	0: Ramp to Stop. Decelerate to stop using the deceleration time in C1-02. 1: Coast to Stop. 2: Fast-Stop. Decelerate to stop using the deceleration time in C1-09. 3: Alarm Only.	Default: 1 Range: 0 to 3	<i>150</i>

## B.8 H Parameters: Multi-Function Terminals

H parameters assign functions to the multi-function input and output terminals.

### ◆ H1: Multi-Function Digital Inputs

No. (Addr. Hex)	Name	Description	Values	Page
H1-03 (400)	Multi-Function Digital Input Terminal S3 Function Selection Term S3 Func Sel	Assigns a function to the multi-function digital inputs through Z2-□□ = 3. Refer to <a href="#">Table B.3</a> for descriptions of setting values. <b>Note:</b> Set unused terminals to F.	Default: 24 Min.: 3 Max.: 60	<a href="#">151</a>
H1-04 (401)	Multi-Function Digital Input Terminal S4 Function Selection Term S4 Func Sel	Assigns a function to the multi-function digital inputs through Z2-□□ = 4. Refer to <a href="#">Table B.3</a> for descriptions of setting values. <b>Note:</b> Set unused terminals to F.	Default: 14 Min.: 3 Max.: 60	<a href="#">151</a>
H1-05 (402)	Multi-Function Digital Input Terminal S5 Function Selection Term S5 Func Sel	Assigns a function to the multi-function digital inputs through Z2-□□ = 5. Refer to <a href="#">Table B.3</a> for descriptions of setting values. <b>Note:</b> Set unused terminals to F.	Default: 3 Min.: 3 Max.: 60	<a href="#">151</a>
H1-06 (403)	Multi-Function Digital Input Terminal S6 Function Selection Term S6 Func Sel	Assigns a function to the multi-function digital inputs through Z2-□□ = 6. Refer to <a href="#">Table B.3</a> for descriptions of setting values. <b>Note:</b> Set unused terminals to F.	Default: 4 Min.: 3 Max.: 60	<a href="#">151</a>
H1-07 (404)	Multi-Function Digital Input Terminal S7 Function Selection Term S7 Func Sel	Assigns a function to the multi-function digital inputs through Z2-□□ = 7. Refer to <a href="#">Table B.3</a> for descriptions of setting values. <b>Note:</b> Set unused terminals to F.	Default: 6 Min.: 3 Max.: 60	<a href="#">151</a>

**Table B.3 H1 Multi-Function Digital Input Selections**

H1-□□ Setting	Function	Description	Page
3	Multi-Step Speed Reference 1 Multi-Step Ref 1	When input terminals are set to Multi-Step Speed References 1 through 3, switching combinations of those terminals will create a multi-step speed sequence using the frequency references set in d1-01 through d1-08.	<a href="#">151</a>
4	Multi-Step Speed Reference 2 Multi-Step Ref 2	When input terminals are set to Multi-Step Speed References 1 through 3, switching combinations of those terminals will create a multi-step speed sequence using the frequency references set in d1-01 through d1-08.	<a href="#">151</a>
6	Jog reference selection Jog Freq Ref	Closed: Jog frequency reference (d1-17) selected. Jog has priority over all other reference sources.	<a href="#">151</a>
C	Analog terminal input selection Term AI Enable	Open: Function assigned by H3-14 is disabled. Closed: Function assigned by H3-14 is enabled.	<a href="#">151</a>
F <1>	Not Used (Through Mode)	Allows serial communications to control the output.	<a href="#">151</a>
10	Up command Up Command 1	The drive accelerates when the Up command terminal closes, and decelerates when the Down command closes. When both terminals are closed or both are open, the drive holds the frequency reference. The Up and Down commands must always be used in conjunction with one another.	<a href="#">151</a>
11	Down command Down Command 1	The drive accelerates when the Up command terminal closes, and decelerates when the Down command closes. When both terminals are closed or both are open, the drive holds the frequency reference. The Up and Down commands must always be used in conjunction with one another.	<a href="#">151</a>
13 <2>	Reverse Jog Reverse Jog	Closed: Runs reverse at the Jog frequency d1-17	<a href="#">152</a>
14	Fault Reset	Closed: Resets faults if the cause is cleared and the Run command is removed.	<a href="#">153</a>
19	PI disable PI Disable	Open: PI control enabled Closed: PI control disabled	<a href="#">153</a>
24	External fault NO/Always Det Coast to Stop	Normally Open, Always Detected, Coast to Stop	<a href="#">153</a>
60	Motor pre-heat 1 Motor Preheat 1	Closed: Triggers Motor pre-heat 1	<a href="#">153</a>

<1> Available in bypass controller software versions VST800298 and later.

<2> Available in bypass controller software versions VST800297 and earlier.

### ◆ H2: Multi-Function Digital Outputs

**Note:** H2-□□ parameters are available in bypass controller software versions VST800298 and later.

No. (Addr. Hex)	Name	Description	Values	Page
H2-01 (040B)	Terminal M1-M2 function selection (relay) M1-M2 Func Sel	Refer to H2 Multi-Function Digital Output Settings on pages <a href="#">340</a> to <a href="#">341</a> for descriptions of setting values.	Default: 0 Range: 0 to 160	<a href="#">153</a>
H2-02 (040C)	Terminal M3-M4 function selection (relay) M3/M4 Func Sel		Default: 1 Range: 0 to 160	<a href="#">153</a>
H2-03 (040D)	Terminal M5-M6 function selection (relay) M5/M6 Func Sel		Default: 2 Range: 0 to 160	<a href="#">153</a>

H2 Multi-Function Digital Output Settings				
H2-□□ Setting	Function	LCD Display	Description	Page
0	During run	During RUN 1	Closed: A Run command is active or voltage is output.	<a href="#">154</a>
1	Zero speed	Zero Speed	Open: Output frequency is above the minimum output frequency set in E1-09. Closed: Output frequency is below the minimum output frequency set in E1-09.	<a href="#">154</a>
2	Speed agree 1	Fref/Fout Agree1	Closed: Output frequency equals the speed reference (plus or minus the hysteresis set to L4-02).	<a href="#">154</a>
3	User-set speed agree 1	Fref/Set Agree 1	Closed: Output frequency and speed reference equal L4-01 (plus or minus the hysteresis set to L4-02).	<a href="#">155</a>
4	Frequency detection 1	Freq Detect 1	Closed: Output frequency is less than or equal to the value in L4-01 with hysteresis determined by L4-02.	<a href="#">155</a>
5	Frequency detection 2	Freq Detect 2	Closed: Output frequency is greater than or equal to the value in L4-01 with hysteresis determined by L4-02.	<a href="#">156</a>
6	Drive ready	Drive Ready	Closed: Power up is complete and the drive is ready to accept a Run command.	<a href="#">156</a>
7	DC bus undervoltage	DC Bus Undervolt	Closed: DC bus voltage is below the Uv trip level set in L2-05.	<a href="#">156</a>
8	During baseblock (N.O.)	BaseBlk 1	Closed: Drive has entered the baseblock state (no output voltage).	<a href="#">156</a>
B	Torque detection 1 (N.O.)	Trq Det 1 N.O.	Closed: An overtorque or undertorque situation has been detected.	<a href="#">157</a>
C	Frequency reference loss	Loss of Ref	Closed: Analog frequency reference has been lost.	<a href="#">157</a>
E	Fault	Fault	Closed: Fault occurred.	<a href="#">157</a>
F	Not Used (Through mode)	Not Used	Set this value when using the terminal in the pass-through mode.	<a href="#">157</a>
10	Minor fault	Minor Fault	Closed: An alarm has been triggered, or the IGBTs have reached 90% of their expected life span.	<a href="#">157</a>
11	Fault reset command active	Reset Cmd Active	Closed: A command has been entered to clear a fault via the input terminals or from the serial network.	<a href="#">157</a>
13	Speed agree 2	Fref/Fout Agree2	Closed: When drive output frequency equals the frequency reference ±L4-04.	<a href="#">157</a>
14	User-set speed agree 2	Fref/Set Agree 2	Closed: When the drive output frequency is equal to the value in L4-03 ±L4-04.	<a href="#">157</a>
15	Frequency detection 3	Freq Detect 3	Closed: When the drive output frequency is less than or equal to the value in L4-03 ±L4-04.	<a href="#">158</a>
16	Frequency detection 4	Freq Detect 4	Closed: When the output frequency is greater than or equal to the value in L4-03 ±L4-04.	<a href="#">158</a>
17	Torque detection 1 (N.C.)	Trq Det 1 N.C.	Open: Overtorque or undertorque has been detected.	<a href="#">157</a>
1A	During Reverse	Reverse Dir	Closed: Drive is running in the reverse direction.	<a href="#">157</a>
1B	During baseblock (N.C.)	BaseBlk 2	Open: Drive has entered the baseblock state (no output voltage).	<a href="#">159</a>
1E	Restart enabled	Dur Flt Restart	Closed: An automatic restart is performed	<a href="#">159</a>
20	Drive overheat pre-alarm (oH)	OH Prealarm	Closed: Heatsink temperature exceeds the parameter L8-02 value, or an external device has triggered an oH2 alarm via multi-function input H1-□□ = B.	<a href="#">159</a>
2F	Maintenance period	Maintenance	Closed: Cooling fan, electrolytic capacitors, IGBTs, or the soft charge bypass relay may require maintenance.	<a href="#">159</a>

H2 Multi-Function Digital Output Settings				
H2-□□ Setting	Function	LCD Display	Description	Page
37	During frequency output	During RUN 2	Open: Either the drive has stopped or baseblock, DC Injection Braking, or Initial Excitation is being performed. Closed: Drive is running the motor (not in a baseblock state and DC Injection is not being performed).	159
39	Watt hour pulse output	Watt-hour Pulse	Output units are determined by H2-06. Outputs a pulse every 200 ms to indicate the kWh count.	160
3D	During speed search	During SpdSrch	Closed: Speed Search is being executed.	160
4C	During fast stop	During Fast Stop	Closed: A Fast Stop command has been entered from the operator or input terminals.	160
4D	oH Pre-alarm time limit	OH Pre-Alarm	Closed: oH pre-alarm time limit has passed.	160
60	Internal cooling fan alarm	Fan Alrm Det	Closed: Internal cooling fan alarm	160
100 to 160	Function 0 to 60 with inverse output Note: A prefix of "!" is added to represent inverse functions on the LCD keypad display. Example: "!"Zero speed"	–	Inverts the output switching of the multi-function output functions. Set the last two digits of 1□□ to reverse the output signal of that specific function.	160

### ◆ H3: Multi-Function Analog Inputs

No. (Addr. Hex)	Name	Description	Values	Page
H3-01 (410)	Terminal A1 Signal Level Selection Term A1 Level	0: 0 to 10 V with zero limit 0: 0-10V, (LowLim=0) 1: 0 to 10 V without zero limit 1: 0-10V, (BipolRef) 2: 4-20 mA 3: 0-20 mA  <b>Note:</b> Use jumper switch S1 to set input terminal A1 for current or voltage.	Default: 0 Range: 0 to 3	160
H3-02 (434)	Terminal A1 Function Selection Term A1 FuncSel	Sets the function of terminal A1.	Default: 0 Range: 0 to 26	161
H3-03 (411) [RUN]	Terminal A1 Gain Setting Terminal A1 Gain	Sets the level of the input value selected in H3-02 when 10 V is input at terminal A1.	Default: 100.0% Min.: -999.9 Max.: 999.9	161
H3-04 (412) [RUN]	Terminal A1 Bias Setting Terminal A1 Bias	Sets the level of the input value selected in H3-02 when 0 V is input at terminal A1.	Default: 0.0% Min.: -999.9 Max.: 999.9	161
H3-09 (417)	Terminal A2 Signal Level Selection Term A2 Level	0: 0 to 10 V with zero limit 0: 0-10V, (LowLim=0) 1: 0 to 10 V without zero limit 1: 0-10V, (BipolRef) 2: 4 to 20 mA 2: 4-20 mA 3: 0 to 20 mA 3: 0-20 mA  <b>Note:</b> Use jumper switch S1 to set input terminal A2 for current or voltage input signal.	Default: 2 Range: 0 to 3	162
H3-10 (418)	Terminal A2 Function Selection Term A2 FuncSel	Sets the function of terminal A2.	Default: 0 Range: 0 to 26	162
H3-11 (419) [RUN]	Terminal A2 Gain Setting Terminal A2 Gain	Sets the level of the input value selected in H3-10 when 10 V (20 mA) is input at terminal A2.	Default: 100.0% Min.: -999.9 Max.: 999.9	162
H3-12 (41A) [RUN]	Terminal A2 Bias Setting Terminal A2 Bias	Sets the level of the input value selected in H3-10 when 0 V (0 or 4 mA) is input at terminal A2.	Default: 0.0% Min.: -999.9 Max.: 999.9	162
H3-13 (41B)	Analog Input Filter Time Constant A1/A2 Filter T	Sets a primary delay filter time constant for terminals A1 and A2. Used for noise filtering.	Default: 0.03 s Min.: 0.00 Max.: 2.00	162

## B.8 H Parameters: Multi-Function Terminals

No. (Addr. Hex)	Name	Description	Values	Page
H3-14 (41C)	Analog Input Terminal Enable Selection A1/A2 Sel	Determines which analog input terminals will be enabled when a digital input programmed for “Analog input enable” (H1-□□ = C) is activated. 1: Terminal A1 only 1: A1 Available 2: Terminal A2 only 2: A2 Available 3: Terminals A1 and A2 3: A1/A2 Available	Default: 2 Range: 1 to 3	162
H3-16 (2F0)	Terminal A1 Offset Term A1 Offset	Adds an offset when the analog signal to terminal A1 is at 0 V.	Default: 0 Min.: -500 Max.: 500	163
H3-17 (2F1)	Terminal A2 Offset Term A2 Offset	Adds an offset when the analog signal to terminal A2 is at 0 V.	Default: 0 Min.: -500 Max.: 500	163

### H3 Multi-Function Analog Input Settings

H3-□□ Setting	Function	Description	Page
0	Frequency bias Freq Ref Bias	10 V = E1-04 (maximum output frequency)	163
1	Frequency gain Freq Ref Gain	0 to 10 V signal allows a setting of 0 to 100%. -10 to 0 V signal allows a setting of -100 to 0%.	163
2	Auxiliary frequency reference 1 (used as a Multi-Step Speed 2) Aux Reference1	10 V = E1-04 (maximum output frequency)	163
3	Auxiliary frequency reference 2 (3rd step analog) Aux Reference2	10 V = E1-04 (maximum output frequency)	164
4	Output voltage bias Voltage Bias	10 V = E1-05 (motor rated voltage)	164
5	Accel/decel time gain Acc/Dec Time Gain	10 V = 100%	164
6	DC Injection Braking current DC Brake Current	10 V = Drive rated current	164
7	Overtorque/undertorque detection level Torque Det Level	10 V = Drive rated current (V/f)	164
8	Stall Prevention level during run Stall Prev Level	10 V = Drive rated current	164
9	Output frequency lower limit level Ref Lower Limit	10 V = E1-04 (maximum output frequency)	165
B	PI feedback PI Feedback1	10 V = 100%	165
C	PI setpoint PI Set Point	10 V = 100%	165
D	Frequency bias Freq Ref Bias 2	10 V = E1-04 (maximum output frequency)	165
E	Motor temperature (PTC input) Motor PTC	10 V = 100%	165
F	Through mode Not Used	Set this value when using the terminal in the pass-through mode.	165
16	Differential PI feedback PI Feedback 2	10 V = 100%	165
1F <1>	HAND Reference Hand Ref	Sets the frequency reference when in HAND Mode and parameter Z1-41, HAND Speed Reference Selection, is set to 1 (Analog).	165
25	Secondary PI setpoint PI2 Setpoint	10 V = S3-02 (maximum output frequency)	165
26	Secondary PI feedback PI2 Feedback	10 V = S3-02 (maximum output frequency)	165

<1> Setting 1F is “HAND Reference” in bypass controller software versions VST800298 and later. Setting 1F is “Not Used (Through Mode)” in bypass controller software versions VST800297 and earlier.

◆ H4: Analog Outputs

No. (Addr. Hex)	Name	LCD Display	Description	Values	Page
H4-01 (41D)	Multi-Function Analog Output Terminal FM Monitor Selection	Term FM FuncSel	Selects the data to be output through multi-function analog output terminal FM. Set the desired monitor parameter to the digits available in U□-□□. For example, enter “103” for U1-03.	Default: 102 Range: 000 to 621	165
H4-02 (41E) RUN	Multi-Function Analog Output Terminal FM Gain	Terminal FM Gain	Sets the signal level at terminal FM that is equal to 100% of the selected monitor value.	Default: 100.0% Min.: -999.9 Max.: 999.9	166
H4-03 (41F) RUN	Multi-Function Analog Output Terminal FM Bias	Terminal FM Bias	Sets the signal level at terminal FM that is equal to 0% of the selected monitor value.	Default: 0.0% Min.: -999.9 Max.: 999.9	166
H4-04 (420)	Multi-Function Analog Output Terminal AM Monitor Selection	Terminal AM Sel	Selects the data to be output through multi-function analog output terminal AM. Set the desired monitor parameter to the digits available in U□-□□. For example, enter “103” for U1-03.	Default: 103 Range: 000 to 621	165
H4-05 (421) RUN	Multi-Function Analog Output Terminal AM Gain	Terminal AM Gain	Sets the signal level at terminal AM that is equal to 100% of the selected monitor value.	Default: 50.0% Min.: -999.9 Max.: 999.9	166
H4-06 (422) RUN	Multi-Function Analog Output Terminal AM Bias	Terminal AM Bias	Sets the signal level at terminal AM that is equal to 0% of the selected monitor value.	Default: 0.0% Min.: -999.9 Max.: 999.9	166
H4-07 (423)	Multi-Function Analog Output Terminal FM Signal Level Selection	Term FM Lvl Sel	0: 0 to 10 V 0: 0-10 VDC 2: 4 to 20 mA 2: 4-20 mA	Default: 0 Range: 0, 2	166
H4-08 (424)	Multi-Function Analog Output Terminal AM Signal Level Selection	Term AM Lvl Sel	0: 0 to 10 V 0: 0-10 VDC 2: 4 to 20 mA 2: 4-20 mA	Default: 0 Range: 0, 2	166

◆ H5: MEMOBUS/Modbus Serial Communication

No. (Addr. Hex)	Name	Description	Values	Page
H5-04 (428) <1>	Stopping Method after Communication Error (CE) Serial Fault Sel	<p><b>Note:</b> The function associated with this parameter is only used internally and is not related to customer serial communications.</p> <p>0: Ramp to Stop 0: Ramp to Stop 1: Coast to Stop 1: Coast to Stop 2: Fast-Stop 2: Fast-Stop 3: Alarm only 3: Alarm Only 4: Run at d1-04 4: Alarm (d1-04)</p>	Default: 3 Range: 0 to 4	167

<1> Parameter is only available in bypass controller software versions VST800297 and earlier.

## B.9 L: Protection Function

L parameters provide protection to the drive and motor, including control during momentary power loss, stall prevention, frequency detection, fault restarts, overtorque and undertorque detection, and other types of hardware protection.

### ◆ L1: Motor Protection

No. (Addr. Hex)	Name	Description	Values	Page
L1-01 (480)	Motor Overload Protection Selection Mtr OL Charact	0: Disabled 0: OL1 Disabled 1: General purpose motor 1: VT Motor (standard fan cooled) The drive may not be able to provide protection when using multiple motors, even if overload is enabled in L1-01. Set L1-01 to 0 and install separate thermal relays to each motor.	Default: 1 Range: 0, 1	168
L1-02 (481)	Motor Overload Protection Time MOL Time Const	Sets the motor thermal overload protection (oL1) time.	Default: 1.0 min Min.: 0.1 Max.: 5.0	169

### ◆ L2: Momentary Power Loss Ride-Thru

No. (Addr. Hex)	Name	Description	Values	Page
L2-01 (485)	Momentary Power Loss Operation Selection PwrL Selection	0: Disabled. 0: Disabled Drive trips on Uv1 fault when power is lost. 1: Recover within the time set in L2-02. 1: Enbl with Timer Uv1 will be detected if power loss is longer than L2-02. <b>Note:</b> L2-02 is dependent on drive model selection and is not accessible. 2: Recover as long as CPU has power. 2: Enbl whl CPU act Uv1 is not detected.	Default: 2 <1> Range: 0 to 2	169
L2-02 (486)	Momentary Power Loss Ride-Thru Time PwrL Ridethru t	Sets the Power Loss Ride-Thru time. Enabled only when L2-01 = 1 or 3.	Default: <2> Min.: 0.0 s Max.: 25.5 s	170
L2-03 (487)	Momentary Power Loss Minimum Baseblock Time PwrL Baseblock t	Sets the minimum wait time for residual motor voltage decay before the drive output reenergizes after performing Power Loss Ride-Thru. Increasing the time set to L2-03 may help if overcurrent or overvoltage occur during Speed Search or during DC Injection Braking.	Default: <2> Min.: 0.1 s Max.: 5.0 s	170
L2-05 (489)	Undervoltage Detection Level (Uv1) PUV Det Level	Sets the DC bus undervoltage trip level.	Default: 190 Vdc <3> <4> Min.: 150 Vdc Max.: 220 Vdc <4>	170

<1> Default is 0 in bypass controller software versions VST800297 and earlier.

<2> Default setting is dependent on parameter o2-04, Drive Model Selection.

<3> Default setting is dependent on parameters o2-04, Drive Model Selection, and E1-01, Input Voltage Setting.

<4> Values shown are specific to 208 Vac. Double the value for 480 Vac.

### ◆ L3: Stall Prevention

No. (Addr. Hex)	Name	Description	Values	Page
L3-02 (490)	Stall Prevention Level during Acceleration StallP Accel Lvl	Used when L3-01 = 1 or 2. 100% is equal to the drive rated current.	Default: <1> Min.: 0% Max.: 150% <1>	170
L3-03 (491)	Stall Prevention Limit during Acceleration StallPAcc LowLim	Sets Stall Prevention lower limit during acceleration when operating in the constant power range. Set as a percentage of drive rated current.	Default: 50% Min.: 0 Max.: 100	171



No. (Addr. Hex)	Name	Description	Values	Page
L3-04 (492)	Stall Prevention Selection during Deceleration StallP Decel Sel	0: Disabled. Deceleration at the active deceleration rate. An ov fault may occur. 0: Disabled 1: General purpose. 1: General Purpose Deceleration is paused when the DC bus voltage exceeds the Stall Prevention level. 2: Intelligent. 2: Intelligent Decelerate as fast as possible while avoiding ov faults. 4: Overexcitation 4: High Flux Brake Deceleration. Decelerates while increasing the motor flux 5: Overexcitation Deceleration 2. 5: High Flux Brake2 Adjust the deceleration rate according to the DC bus voltage.	Default: 1 Range: 0 to 2; 4, 5	171
L3-06 (494)	Stall Prevention Level during Run StallP Run Level	Enabled when L3-05 is set to 1 or 2. 100% is equal to the drive rated current.	Default: <1> Min.: 30% Max.: 150% <1>	172
L3-11 (4C7)	Overvoltage Suppression Function Selection OV Inhibit Sel	Enables or disables the ov suppression function, which allows the drive to change the output frequency as the load changes to prevent an ov fault. 0: Disabled 0: Disabled 1: Enabled 1: Enabled	Default: 0 Range: 0, 1	172
L3-25 (46F)	Load Inertia Ratio Load Inertia Rat	Sets the ratio between the motor and machine inertia.	Default: 1.0 Min.: 1.0 Max.: 1000.0	173

<1> Upper limit is dependent on parameter L8-38, Frequency Reduction Selection.

### ◆ L4: Speed Detection

No. (Addr. Hex)	Name	LCD Display	Description	Values	Page
L4-05 (49D)	Frequency Reference Loss Detection Selection	Ref Loss Sel 0: Stop 1: Run@L4-06PrevRef	0: Stop. Drive stops when the frequency reference is lost. 1: Run. Drive runs at a reduced speed when the frequency reference is lost.	Default: 1 Range: 0, 1	173
L4-06 (4C2)	Frequency Reference at Reference Loss	Fref at Floss	Sets the percentage of the frequency reference that the drive should run with when the frequency reference is lost.	Default: 80.0% Min.: 0.0 Max.: 100.0	173

### ◆ L5: Fault Restart

No. (Addr. Hex)	Name	LCD Display	Description	Values	Page
L5-01 (49E)	Number of Auto Restart Attempts	Num of Restarts	Sets the number of times the drive may attempt to restart after the following faults occur: GF, LF, oC, ov, PF, oL1, oL2, oL3, STo, Uv1.	Default: 0 Min.: 0 Max.: 10	174
L5-02 (49F)	Auto Restart Fault Output Operation Selection	Restart Sel 0: Flt Outp Disabld 1: Flt Outp Enabled	0: Fault output not active. 1: Fault output active during restart attempt.	Default: 0 Range: 0, 1	174
L5-03 (4A0)	Time to Continue Making Fault Restarts	Max Restart Time	Enabled only when L5-05 is set to 0. Causes a fault if a fault restart cannot occur after the set time passes.	Default: 180.0 s Min.: 0.0 Max.: 600.0	174
L5-04 (46C)	Fault Reset Interval Time	Flt Reset Wait T	Sets the amount of time to wait between performing fault restarts.	Default: 10.0 s Min.: 0.5 Max.: 600.0	176
L5-05 (467)	Fault Reset Operation Selection	Fault Reset Sel 0: Continuous 1: Use L5-04 Time	0: Continuously attempt to restart while incrementing restart counter only at a successful restart (same as F7 and G7). 1: Attempt to restart with the interval time set in L5-04 and increment the restart counter with each attempt (same as V7).	Default: 1 Range: 0, 1	176

## B.9 L: Protection Function

### ◆ L6: Torque Detection

No. (Addr. Hex)	Name	Description	Values	Page
L6-01 (4A1) <1>	Torque Detection Selection 1	0: Disabled 1: oL3 detection only active during speed agree, operation continues after detection 2: oL3 detection always active during run, operation continues after detection 3: oL3 detection only active during speed agree, output shuts down on an oL3 fault 4: oL3 detection always active during run, output shuts down on an oL3 fault 5: UL3 detection only active during speed agree, operation continues after detection 6: UL3 detection always active during run, operation continues after detection 7: UL3 detection only active during speed agree, output shuts down on an oL3 fault 8: UL3 detection always active during run, output shuts down on an oL3 fault	Default: 0 Range: 0 to 8	177
L6-02 (4A2)	Torque Detection Level 1 Torq Det 1 Lvl	Sets the overtorque and undertorque detection level.	Default: 15% Min.: 0 Max.: 300	178
L6-03 (4A3)	Torque Detection Time 1 Torq Det 1 Time	Sets the time an overtorque or undertorque condition must exist to trigger torque detection 1.	Default: 10.0 s Min.: 0.0 Max.: 10.0	178
L6-13 (62E)	Motor Underload Protection Selection Underload Select	Sets the motor underload protection (UL□) based on motor load. 0: Overtorque/undertorque detection enabled 0: Base Freq Enable 1: Base frequency motor load enabled 1: Max Freq Enable	Default: 0 Range: 0, 1	178
L6-14 (62F)	Motor Underload Protection Level at Minimum Frequency Underload Level	Sets the UL6 detection level at minimum frequency by percentage of drive rated current.	Default: 15% Min.: 0 Max.: 300	178

<1> Available in bypass controller software versions VST800298 and later.

### ◆ L8: Drive Protection

No. (Addr. Hex)	Name	Description	Values	Page
L8-02 (4AE)	Overheat Alarm Level OH Pre-Alarm Lvl	An overheat alarm occurs when heatsink temperature exceeds the L8-02 level.	Default: <1> Min.: 50 °C Max.: 150 °C	179
L8-05 (4B1)	Input Phase Loss Protection Selection Inp Ph Loss Det	Selects the detection of input current phase loss, power supply voltage imbalance, or main circuit electrolytic capacitor deterioration. 0: Disabled 0: Disabled 1: Enabled 1: Enabled	Default: 1 Range: 0, 1	179
L8-06 (4B2)	Input Phase Detection Level Inp Ph Loss Lvl	When ripple is observed in the DC bus, expansion of the input bias is calculated. This value becomes the input phase if the difference between the maximum and minimum values of the ripple is greater than the value set to L8-06. Detection Level = 100% = Voltage class x $\sqrt{2}$	Default: <1> Min.: 0.0% Max.: 50.0%	179
L8-07 (4B3)	Output Phase Loss Protection Selection Outp Ph Loss Det	0: Disabled 0: Disabled 1: Enabled 1: 1PH Loss Det (triggered by a single phase loss) 2: Enabled 2: 2/3PH Loss Det (triggered when two phases are lost)	Default: 1 Range: 0 to 2	179
L8-09 (4B5)	Output Ground Fault Detection Selection Grnd Flt Det Sel	0: Disabled 0: Disabled 1: Enabled 1: Enabled	Default: <1> Range: 0, 1	180
L8-38 (4EF)	Carrier Frequency Reduction Fc Reduct dur OL	0: Disabled 0: Disabled 1: Enabled below 6 Hz 1: Active below 6Hz 2: Enabled for the entire speed range 2: Active @ any Spd	Default: <1> Range: 0 to 2	180

<1> Default setting is dependent on parameter o2-04, Drive Model Selection.

## B.10 n: Special Adjustment

The n parameters adjust more advanced performance characteristics such as Hunting Prevention, speed feedback detection, High Slip Braking, and Online Tuning for motor line-to-line resistance.

### ◆ n1: Hunting Prevention

No. (Addr. Hex)	Name	Description	Values	Page
n1-01 (580)	Hunting Prevention Selection Hunt Prev Select	0: Disabled 0: Disabled 1: Enabled 1: Enabled	Default: 1 Range: 0, 1	<a href="#">181</a>
n1-02 (581)	Hunting Prevention Gain Setting Hunt Prev Gain	If the motor vibrates while lightly loaded, increase the gain by 0.1 until vibration ceases. If the motor stalls, decrease the gain by 0.1 until the stalling ceases.	Default: 1.00 Min.: 0.00 Max.: 2.50	<a href="#">181</a>

### ◆ n3: High Slip Braking (HSB) and Overexcitation Braking

No. (Addr. Hex)	Name	Description	Values	Page
n3-04 (58B)	High-Slip Braking Overload Time HSB OL Time	Sets the time required for an HSB overload fault (oL7) to occur when the drive output frequency does not change during an HSB stop. This parameter does not typically require adjustment.	Default: 40 s Min.: 30 Max.: 1200	<a href="#">181</a>
n3-13 (531)	Overexcitation Deceleration Gain Hflux Brake Gain	Sets the gain applied to the V/f pattern during Overexcitation Deceleration (L3-04 = 4).	Default: 1.10 Min.: 1.00 Max.: 1.40	<a href="#">182</a>

## B.11 o: Operator-Related Settings

The o parameters set up the digital operator displays.

### ◆ o1: HOA Keypad Display Selection

No. (Addr. Hex)	Name	Description	Values	Page
o1-01 (500) RUN <I>	Drive Mode Unit Monitor Selection	Selects the content of the last monitor that is shown when scrolling through Drive Mode display. Enter the last three digits of the monitor parameter number to be displayed: U□-□□.	Default: 106 Range: 104 to 699	183
o1-02 (501) RUN <I>	Drive Mode Unit Monitor Power Up	1: Frequency reference (U1-01) 2: Direction 3: Output frequency (U1-02) 4: Output current (U1-03) 5: User Monitor	Default: 1 Range: 1 to 5	183
o1-03 (502)	HOA Keypad Operator Display Selection Display Unit Sel	Sets the units the drive should use to display the frequency reference and motor speed monitors. 0: 0.01 Hz 0: 0.01 Hz 1: 0.01% 1: 0.01%(100% = E1-04) 2: r/min 2: r/min (calculated using the number of motor poles setting in E2-04, E4-04, or E5-04) 3: User-selected units 3: User Units (set by o1-10 and o1-11)	Default: 0 Range: 0 to 3	183
o1-09 (51C)	Frequency Reference Display Units Fref Disp Unit	Sets unit display for the frequency reference parameters and frequency related monitors when o1-03 > 40. 0: "WC 0: "WC(Inch of water) 1: PSI 1: PSI(Pounds per square inch) 2: GPM 2: GPM(Gallons per minute) 3: F 3: °F (Degrees Fahrenheit) 4: CFM 4: CFM(Cubic feet per minute) 5: CMH 5: CMH(Cubic meters per hour) 6: LPH 6: LPH(Liters per hour) 7: LPS 7: LPS(Liters per second) 8: Bar 8: Bar(Bar) 9: Pa 9: Pa(Pascal) 10: C 10: °C (Degrees Celsius) 11: Mtr 11: Mtr(Meters) 12: Ft 12: Ft(Feet) 13: LPM 13: LPM(Liters per minute) 14: CMM 14: CMM(Cubic meters per minute) 16: None 16: No Unit	Default: 16 Range: 0 to 14; 16	183
o1-10 (520)	User-Set Display Units Maximum Value UserDisp Scaling	These settings define the display values when o1-03 is set to 3. o1-10 sets the display value that is equal to the maximum output frequency. o1-11 sets the position of the decimal position.	Default: <2> Range: 1 to 60000	185
o1-11 (521)	User-Set Display Units Decimal Display UserDisp Dec Sel	0: No decimal point 0: No Dec (XXXXX) 1: One decimal point 1: 1 Dec (XXXX.X) 2: Two decimal points 2: 2 Dec (XXX.XX) 3: Three decimal points 3: 3 Dec (XX.XXX)	Default: <2> Range: 0 to 3	185

<I> Available in bypass controller software versions VST800401 and later.

<2> Default setting is dependent on parameter o1-03, HOA Keypad Display Selection.

### ◆ o2: HOA Keypad Functions

No. (Addr. Hex)	Name	Description	Values	Page
o2-04 (508)	Drive Model Selection Inverter Model #	Enter the drive model. Setting required only if installing a new control board.	Default: Determined by drive capacity	185

## ◆ o4: Maintenance Monitor Settings

No. (Addr. Hex)	Name	Description	Values	Page
o4-03 (050E)	Cooling Fan Operation Time Setting FanElapsTimeCnt	Sets the value of the fan operation time monitor U4-03 in units of 10 h.	Default: 0 h Min.: 0 Max.: 9999	<a href="#">185</a>
o4-11 (0510) </>	U2, U3, and UB-09 to UB-16 Initialization	0: The drive and bypass keep the previously saved record concerning fault trace and fault history. 1: Resets the data for the U2-□□, U3-□□, and UB-09 to UB-16 monitors. Setting o4-11 to 1 and pressing the ENTER key erases fault data in the bypass and drive and returns the display to 0.	Default: 0 Range: 0, 1	<a href="#">185</a>

<1> Available in bypass controller software versions VST800298 and later.

## B.12 S: Special Application

### ◆ S1: Dynamic Noise Control Function

No. (Addr. Hex)	Name	LCD Display	Description	Values	Page
S1-01 (3200)	Dynamic Audible Noise Control Function Selection	Dyn Noise Ctrl 0: Disabled 1: Enabled	Reduces audible noise by decreasing the output voltage in variable torque applications with light loads. 0: Disabled 1: Enabled	Default: 1 Range: 0, 1	187
S1-02 (3201)	Voltage Reduction Rate	Volt Reduce Amt	Sets the rate at which the output voltage will be reduced as a percentage of the V/f pattern when operating with no load.	Default: 50.0% Min.: 50.0 Max.: 100.0	187
S1-03 (3202)	Voltage Restoration Level	V Reduce On Lvl	Sets the level when the drive should start restoring the voltage as a percentage of the drive rated torque.	Default: 20.0% Min.: 0.0 Max.: 90.0	187
S1-04 (3203)	Voltage Restoration Complete Level	V Reduce Off Lvl	Sets the level at which voltage restoration for the V/f pattern is complete as a percentage of the drive rated torque. If the output torque rises above the value of S1-04, then the voltage will be controlled in a manner specified by the V/f pattern setting.	Default: 50.0% Min.: S1-03 + 10.0 Max.: 100.0	188
S1-05 (3204)	Voltage Restoration Sensitivity Time Constant	Sensitivity Time	Sets the level of sensitivity of the output torque and LPF time constant for the voltage reduction rate. The level of sensitivity can be adjusted in accordance with the load response.	Default: 1.000 s Min.: 0.000 Max.: 3.000	188
S1-06 (3205)	Voltage Restoration Time Constant at Impact	Impact Load Time	Sets the voltage restoration time constant if an impact load is added.	Default: 0.050 s Min.: 0.000 Max.: 1.000	188

### ◆ S2: Sequence Timers

No. (Addr. Hex)	Name	LCD Display	Description	Values	Page
S2-01 (3206)	Sequence Timer 1 Start Time	Tmr 1 Start Time	Sets the start time for timer 1. The value must be set less than or equal to S2-02.	Default: 00:00 Min.: 00:00 Max.: 24:00	189
S2-02 (3207)	Sequence Timer 1 Stop Time	Tmr 1 Stop Time	Sets the stop time for timer 1. The value must be set greater than or equal to S2-01.	Default: 00:00 Min.: 00:00 Max.: 24:00	189
S2-03 (3208)	Sequence Timer 1 Day Selection	Tmr 1 Day Sel 0: Timer disabled 1: Daily 2: Mon - Fri 3: Sat - Sun 4: Monday 5: Tuesday 6: Wednesday 7: Thursday 8: Friday 9: Saturday 10: Sunday	Sets the days for which sequence timer 1 is active. 0: Timer disabled 1: Daily 2: Mon - Fri 3: Sat - Sun 4: Monday 5: Tuesday 6: Wednesday 7: Thursday 8: Friday 9: Saturday 10: Sunday	Default: 0 Range: 0 to 10	189
S2-04 (3209)	Sequence Timer 1 Selection	Tmr 1 Seq Sel 0: Digital Out Only 1: Run 2: Run - PI Disable	Sets the action that occurs when sequence timers 1 is active. 0: Digital output only 1: Run 2: Run - PI disable	Default: 0 Range: 0 to 2	190
S2-05 (320A)	Sequence Timer 1 Reference Source	Tmr 1 Ref Source 0: Operator (d1-01) 1: Operator (d1-02) 2: Operator (d1-03) 3: Operator (d1-04) 4: Terminals 5: Serial Com	Selects the frequency reference source used for running the drive when sequence timer 1 is active (only applicable when S2-04 is set to 1 or 2). 0: Operator (d1-01) 1: Operator (d1-02) 2: Operator (d1-03) 3: Operator (d1-04) 4: Terminals 5: Serial communication	Default: 0 Range: 0 to 5	190
S2-06 (320B)	Sequence Timer 2 Start Time	Tmr 2 Start Time	Sets the start time for timer 2. The value must be set less than or equal to S2-07.	Default: 00:00 Min.: 00:00 Max.: 24:00	189

No. (Addr. Hex)	Name	LCD Display	Description	Values	Page
S2-07 (320C)	Sequence Timer 2 Stop Time	Tmr 2 Stop Time	Sets the stop time for timer 2. The value must be set greater than or equal to S2-06.	Default: 00:00 Min.: 00:00 Max.: 24:00	189
S2-08 (320D)	Sequence Timer 2 Day Selection	Tmr 2 Day Sel 0: Timer disabled 1: Daily 2: Mon - Fri 3: Sat - Sun 4: Monday 5: Tuesday 6: Wednesday 7: Thursday 8: Friday 9: Saturday 10: Sunday	Sets the days for which sequence timer 2 is active. 0: Timer disabled 1: Daily 2: Mon - Fri 3: Sat - Sun 4: Monday 5: Tuesday 6: Wednesday 7: Thursday 8: Friday 9: Saturday 10: Sunday	Default: 0 Range: 0 to 10	189
S2-09 (320E)	Sequence Timer 2 Selection	Tmr 2 Seq Sel 0: Digital Out Only 1: Run 2: Run - PI Disable	Sets the action that occurs when sequence timers 2 is active. 0: Digital output only 1: Run 2: Run - PI disable	Default: 0 Range: 0 to 2	190
S2-10 (320F)	Sequence Timer 2 Reference Source	Tmr 2 Ref Source 0: Operator (d1-01) 1: Operator (d1-02) 2: Operator (d1-03) 3: Operator (d1-04) 4: Terminals 5: Serial Com	Selects the frequency reference source used for running the drive when sequence timer 2 is active (only applicable when S2-09 is set to 1 or 2). 0: Operator (d1-01) 1: Operator (d1-02) 2: Operator (d1-03) 3: Operator (d1-04) 4: Terminals 5: Serial communication	Default: 0 Range: 0 to 5	190
S2-11 (3210)	Sequence Timer 3 Start Time	Tmr 3 Start Time	Sets the start time for timer 3. The value must be set less than or equal to S2-12.	Default: 00:00 Min.: 00:00 Max.: 24:00	189
S2-12 (3211)	Sequence Timer 3 Stop Time	Tmr 3 Stop Time	Sets the stop time for timer 3. The value must be set greater than or equal to S2-11.	Default: 00:00 Min.: 00:00 Max.: 24:00	189
S2-13 (3212)	Sequence Timer 3 Day Selection	Tmr 3 Day Sel 0: Timer disabled 1: Daily 2: Mon - Fri 3: Sat - Sun 4: Monday 5: Tuesday 6: Wednesday 7: Thursday 8: Friday 9: Saturday 10: Sunday	Sets the days for which sequence timer 3 is active. 0: Timer disabled 1: Daily 2: Mon - Fri 3: Sat - Sun 4: Monday 5: Tuesday 6: Wednesday 7: Thursday 8: Friday 9: Saturday 10: Sunday	Default: 0 Range: 0 to 10	189
S2-14 (3213)	Sequence Timer 3 Selection	Tmr 3 Seq Sel 0: Digital Out Only 1: Run 2: Run - PI Disable	Sets the action that occurs when sequence timer 3 is active. 0: Digital output only 1: Run 2: Run - PI disable	Default: 0 Range: 0 to 2	190
S2-15 (3214)	Sequence Timer 3 Reference Source	Tmr 3 Ref Source 0: Operator (d1-01) 1: Operator (d1-02) 2: Operator (d1-03) 3: Operator (d1-04) 4: Terminals 5: Serial Com	Selects the frequency reference source used for running the drive when sequence timer 3 is active (only applicable when S2-14 is set to 1 or 2). 0: Operator (d1-01) 1: Operator (d1-02) 2: Operator (d1-03) 3: Operator (d1-04) 4: Terminals 5: Serial communication	Default: 0 Range: 0 to 5	190
S2-16 (3215)	Sequence Timer 4 Start Time	Tmr 4 Start Time	Sets the start time for timer 4. The value must be set less than or equal to S2-17.	Default: 00:00 Min.: 00:00 Max.: 24:00	189
S2-17 (3216)	Sequence Timer 4 Stop Time	Tmr 4 Stop Time	Sets the stop time for timer 4. The value must be set greater than or equal to S2-16.	Default: 00:00 Min.: 00:00 Max.: 24:00	189

## B.12 S: Special Application

No. (Addr. Hex)	Name	LCD Display	Description	Values	Page
S2-18 (3217)	Sequence Timer 4 Day Selection	Tmr 4 Day Sel 0: Timer disabled 1: Daily 2: Mon - Fri 3: Sat - Sun 4: Monday 5: Tuesday 6: Wednesday 7: Thursday 8: Friday 9: Saturday 10: Sunday	Sets the days for which sequence timer 4 is active. 0: Timer disabled 1: Daily 2: Mon - Fri 3: Sat - Sun 4: Monday 5: Tuesday 6: Wednesday 7: Thursday 8: Friday 9: Saturday 10: Sunday	Default: 0 Range: 0 to 10	<a href="#">189</a>
S2-19 (3218)	Sequence Timer 4 Selection	Tmr 4 Seq Sel 0: Digital Out Only 1: Run 2: Run - PI Disable	Sets the action that occurs when sequence timer 4 is active. 0: Digital output only 1: Run 2: Run - PI disable	Default: 0 Range: 0 to 2	<a href="#">190</a>
S2-20 (3219)	Sequence Timer 4 Reference Source	Tmr 4 Ref Source 0: Operator (d1-01) 1: Operator (d1-02) 2: Operator (d1-03) 3: Operator (d1-04) 4: Terminals 5: Serial Com	Selects the frequency reference source used for running the drive when sequence timer 4 is active (only applicable when S2-19 is set to 1 or 2). 0: Operator (d1-01) 1: Operator (d1-02) 2: Operator (d1-03) 3: Operator (d1-04) 4: Terminals 5: Serial communication	Default: 0 Range: 0 to 5	<a href="#">190</a>

### ◆ T: Motor Tuning

Enter data into the following parameters to tune the motor and drive for optimal performance. When the drive is not accessible, the current values of these parameters are not accessible. The default values are set by the Bypass Controller when a Bypass Control Parameter Initialize (Z1-01 = 1, 2, or 3) command is given.

### ◆ T1: Induction Motor Auto-Tuning

No. (Addr. Hex)	Name	Description	Values	Page
T1-00 (0700)	Motor 1/Motor 2 Selection	1: Motor 1 2: Motor 2	Default: 1 Range: 1, 2	<a href="#">114</a>
T1-01 (0701) </>	Auto-Tuning Mode Selection Tuning Mode Sel	2: Stationary Auto-Tuning for Line-to-Line Resistance 2: Term Resistance 3: Rotational Auto-Tuning for V/f Control Energy Saving 3: V/f Engy Sav Tun	Default: 2 Range: 2, 3	<a href="#">114</a>
T1-02 (0702)	Motor Rated Power Mtr Rated Power	Sets the motor rated power as specified on the motor nameplate. <b>Note:</b> Use the following formula to convert horsepower into kilowatts: 1HP = 0.746 kW.	Default: <> Min.: 0.00 kW Max.: 650.00 kW	<a href="#">114</a>
T1-03 (0703)	Motor Rated Voltage Rated Voltage	Sets the motor rated voltage as specified on the motor nameplate.	Default: 200.0 V <3> Min: 0.0 Max: 255.0 <3>	<a href="#">114</a>
T1-04 (0704)	Motor Rated Current Rated Current	Sets the motor rated current as specified on the motor nameplate.	Default: <> Min.: 10% of drive rated current Max.: 200% of drive rated current	<a href="#">115</a>
T1-05 (0705)	Motor Base Frequency Rated Frequency	Sets the rated frequency of the motor as specified on the motor nameplate.	Default: 60.0 Hz Min.: 0.0 Max.: 240.0	<a href="#">115</a>
T1-06 (0706)	Number of Motor Poles Number of Poles	Sets the number of motor poles as specified on the motor nameplate.	Default: 4 Min.: 2 Max.: 48	<a href="#">115</a>
T1-07 (0707)	Motor Base Speed Rated Speed	Sets the rated speed of the motor as specified on the motor nameplate.	Default: 1750 r/min Min.: 0 Max.: 14400	<a href="#">115</a>



No. (Addr. Hex)	Name	Description	Values	Page
T1-11 (070B)	Motor Iron Loss <small>Mtr Iron Loss(W)</small>	Sets the iron loss for determining the Energy Saving coefficient. The value is set to E2-10 (motor iron loss) set when the power is cycled. If T1-02 is changed, a default value appropriate for the motor capacity that was entered will appear.	Default: 14 W <4> Min.: 0 Max.: 65535	115

- <1> The availability of certain Auto-Tuning methods depends on the control mode selected for the drive.
- <2> Default setting is dependent on parameter o2-04, Drive Model Selection.
- <3> Values shown are specific to 208 Vac. Double the value for 480 Vac.
- <4> Default setting value differs depending on the motor code value and motor parameter settings.

## B.13 U: Monitors

Monitor parameters allow the user to view drive status, fault information, and other data concerning drive operation.

### ◆ UB: Bypass Control Monitors

No. (Addr. Hex)	Name	Description	Unit
UB-01 (8780)	Motor Current	Format is XXX.X amps.	Amp
UB-02 (8781)	Bypass Digital Input States	View status of bypass digital inputs XXXXXXXX Where X = 0 (not asserted) or 1 (asserted) The right-most digit is the status of digital input 1.	–
UB-03 (8782)	Bypass Digital Output States	View status of bypass digital outputs XXXXXXXX Where X = 0 (not asserted) or 1 (asserted) The right-most digit is the status of digital output 1.	–
UB-04 (8783)	Bypass Digital Output States	View status of bypass digital outputs XXXXXXXX Where X = 0 (not asserted) or 1 (asserted) The right-most digit is the status of digital output 9.	–
UB-05 (8784)	Bypass Controller Status Register 1	<p>UB-05 = 00000000</p> <ul style="list-style-type: none"> <li><input type="checkbox"/> HAND Mode</li> <li><input type="checkbox"/> OFF Mode</li> <li><input type="checkbox"/> AUTO Mode</li> <li><input type="checkbox"/> DRIVE Mode</li> <li><input type="checkbox"/> BYPASS Mode</li> <li><input type="checkbox"/> Smoke Purge Bypass Active</li> <li><input type="checkbox"/> Smoke Purge Drive Active</li> <li><input type="checkbox"/> Safety Open</li> </ul>	–
UB-06 (8785)	Bypass Controller Status Register 2	<p>UB-06 = 00000000</p> <ul style="list-style-type: none"> <li><input type="checkbox"/> BAS Interlock Open</li> <li><input type="checkbox"/> RUN Active</li> <li><input type="checkbox"/> Fault Active</li> <li><input type="checkbox"/> Auto Transfer Active</li> <li><input type="checkbox"/> Remote Transfer Active</li> <li><input type="checkbox"/> Energy Savings Active</li> <li><input type="checkbox"/> Motor 1 Selected</li> <li><input type="checkbox"/> Motor 2 Selected</li> </ul> <p><b>Note:</b> When read over serial communications, address 8785H, contains two additional bits of information: Bit 8: "0" when Z1-07 = 2, otherwise "1". Bit 9: "0" when Z1-08 = 2, otherwise "1".</p>	–
UB-07 (8786)	Bypass Controller Active Faults Register 1	<p>UB-07 = 00000000</p> <ul style="list-style-type: none"> <li><input type="checkbox"/> Drive Fault</li> <li><input type="checkbox"/> Safety Open</li> <li><input type="checkbox"/> BAS Interlock Open Time Out</li> <li><input type="checkbox"/> External Fault Bypass (EFB)</li> <li><input type="checkbox"/> Reserved</li> <li><input type="checkbox"/> Motor Overload</li> <li><input type="checkbox"/> External Motor 1 Overload</li> <li><input type="checkbox"/> External Motor 2 Overload</li> </ul>	–

No. (Addr. Hex)	Name	Description	Unit
UB-08 (8787)	Bypass Controller Active Faults Register 2	<p style="text-align: center;">UB-08 = 00000000</p> <ul style="list-style-type: none"> <li>0 Phase Loss Brownout</li> <li>0 Phase Loss Blackout</li> <li>0 No Drive Comms</li> <li>0 Available</li> <li>0 Option Board Comms</li> <li>0 Loss of Load</li> <li>0 Serial Communications Fault</li> <li>0 Available</li> </ul>	–
UB-09 (8788)	Current Fault	Displays the current fault. <i>Refer to Bypass Fault Codes on page 420</i> for details.	–
UB-10 (8789)	Current Fault Year	Displays the year of the current fault.	–
UB-11 (878A)	Current Fault Month Day	Displays the month and day of the current fault.	–
UB-12 (878B)	Current Fault Hour Minute	Displays the hour and minute of the current fault.	–
UB-13 (878C)	Previous Fault	Displays the previous fault. <i>Refer to Bypass Fault Codes on page 420</i> for details.	–
UB-14 (878D)	Previous Fault Year	Displays the year of the previous fault.	–
UB-15 (878E)	Previous Fault Month Day	Displays the month and day of the previous fault.	–
UB-16 (878F)	Previous Fault Hour Minute	Displays the hour and minute of the previous fault.	–
UB-17 (8790)	Contactors Voltage (120 VAC)	Displays the measured voltage for the power going to the contactor coils.	1 Vac
UB-18 (8791)	Software Version	Displays the software version currently programmed into the bypass.	–
UB-19 (8792)	Date Year	Displays the current year.	–
UB-20 (8793)	Date Month & Day	Displays the current date (Month and Date).	–
UB-21 (8794)	Time Hour & Minute	Displays the current time (Hours and Minutes).	–
UB-90 (87A0)	Service Register 0	Unfiltered CT1 current	–
UB-91 (87A1)	Service Register 1	Unfiltered CT2 current	–
UB-92 (87A2)	Service Register 2	Electronic overload calculations	–
UB-93 (87A3)	Service Register 3	BACnet messages sent	–
UB-94 (87A4)	Service Register 4	BACnet received messages errored	–
UB-96 (87DF)	Bypass Unbalance Level	Displays the percent of current unbalance when operating in Bypass Mode.	0.0 to 100.0%

Parameter List

B

◆ U1: Operation Status Monitors

No. (Addr. Hex)	Name	Description	Analog Output Level	Unit
U1-01 (40)	Frequency Reference Frequency Ref	Monitors the frequency reference. Display units are determined by o1-03.	10 V: Max frequency	0.01 Hz
U1-02 (41)	Output Frequency Output Freq	Displays the output frequency. Display units are determined by o1-03.	10 V: Max frequency	0.01 Hz

## B.13 U: Monitors

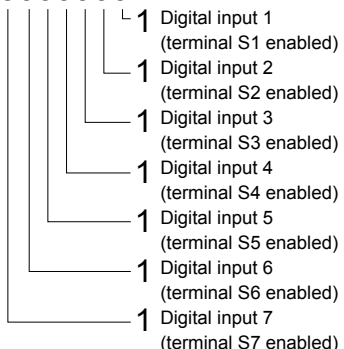
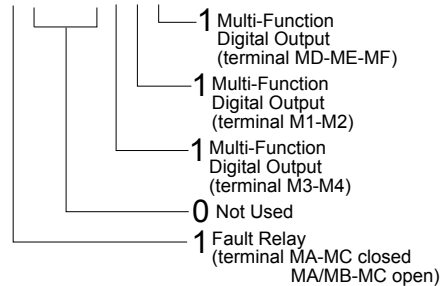
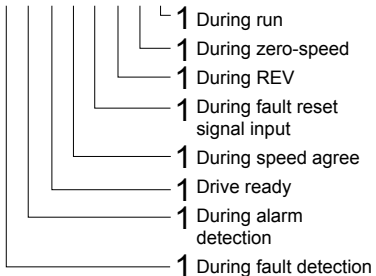
No. (Addr. Hex)	Name	Description	Analog Output Level	Unit
U1-03 (42)	Output Current Output Current	Displays the output current.	10 V: Drive rated current	0.1 A <2>
U1-04 (43)	Control Method Control Method	0: V/f Control	No signal output available	–
U1-06 (45)	Output Voltage Reference Output Voltage	Displays the output voltage.	10 V: 200 Vrms <3>	0.1 Vac
U1-07 (46)	DC Bus Voltage DC Bus Voltage	Displays the DC bus voltage.	10 V: 400 V <3>	1 Vdc
U1-08 (47)	Output Power Output kWatts	Displays the output power (this value is calculated internally).	10 V: Drive rated power (kW)	<1>
U1-10 (49)	Input Terminal Status Input Term Sts	Displays the input terminal status. <b>U1 - 10 = 00000000</b> 	No signal output available	–
U1-11 (4A)	Output Terminal Status Output Term Sts	Displays the output terminal status. <b>U1 - 11 = 00000000</b> 	No signal output available	–
U1-12 (4B)	Drive Status Int Ctl Sts 1	Verifies the drive operation status. <b>U1 - 12 = 00000000</b> 	No signal output available	–
U1-13 (4E)	Terminal A1 Input Level Term A1 Level	Displays the signal level to analog input terminal A1.	10 V: 100%	0.1%
U1-14 (4F)	Terminal A2 Input Level Term A2 Level	Displays the signal level to analog input terminal A2.	10 V: 100%	0.1%
U1-16 (53)	Output Frequency after Soft Starter SFS Output	Displays output frequency with ramp time and S-curves. Units determined by o1-03.	10 V: Max frequency	0.01 Hz

No. (Addr. Hex)	Name	Description	Analog Output Level	Unit
U1-18 (61)	oPE Fault Parameter OPE Error Code	Displays the parameter number that caused the oPE□□ or Err (EEPROM write error) error.	No signal output available	–
U1-25 (4D)	Software Number (Flash) CPU 1 SW Number	FLASH ID	No signal output available	–
U1-26 (5B)	Software No. (ROM) CPU 2 SW Number	ROM ID	No signal output available	–

<1> The number of decimal places in the parameter value depends on the drive model. *Refer to Defaults by Drive Model on page 372* for details.

<2> When reading the value of this monitor via MEMOBUS/Modbus, a value of 8192 is equal to 100% of the drive rated output current.

<3> Values shown are specific to 208 Vac. Double the value for 480 Vac.

## ◆ U2: Fault Trace

No. (Addr. Hex)	Name	Description	Analog Output Level	Unit
U2-01 (80)	Current Fault Current Fault	Displays the current fault.	No signal output available	–
U2-02 (81)	Previous Fault Last Fault	Displays the previous fault.	No signal output available	–
U2-03 (82)	Frequency Reference at Previous Fault Frequency Ref	Displays the frequency reference at the previous fault.	No signal output available	0.01 Hz
U2-04 (83)	Output Frequency at Previous Fault Output Freq	Displays the output frequency at the previous fault.	No signal output available	0.01 Hz
U2-05 (84)	Output Current at Previous Fault Output Current	Displays the output current at the previous fault.	No signal output available	<1> <2>
U2-07 (86)	Output Voltage at Previous Fault Output Voltage	Displays the output voltage at the previous fault.	No signal output available	0.1 Vac
U2-08 (87)	DC Bus Voltage at Previous Fault DC Bus Voltage	Displays the DC bus voltage at the previous fault.	No signal output available	1 Vdc
U2-09 (88)	Output Power at Previous Fault Output kWatts	Displays the output power at the previous fault.	No signal output available	0.1 kW
U2-11 (8A)	Input Terminal Status at Previous Fault Input Term Sts	Displays the input terminal status at the previous fault. Displayed as in U1-10.	No signal output available	–
U2-12 (8B)	Output Terminal Status at Previous Fault Output Term Sts	Displays the output status at the previous fault. Displays the same status displayed in U1-11.	No signal output available	–
U2-13 (8C)	Drive Operation Status at Previous Fault Inverter Status	Displays the operation status of the drive at the previous fault. Displays the same status displayed in U1-12.	No signal output available	–
U2-14 (8D)	Cumulative Operation Time at Previous Fault Elapsed time	Displays the cumulative operation time at the previous fault.	No signal output available	1 h
U2-15 (7E0)	Soft Starter Speed Reference at Previous Fault SFS Output	Displays the speed reference for the soft starter at the previous fault.	No signal output available	0.01 Hz
U2-16 (7E1)	Motor q-Axis Current at Previous Fault Motor Iq Current	Displays the q-axis current for the motor at the previous fault.	No signal output available	0.10%
U2-17 (7E2)	Motor d-Axis Current at Previous Fault Motor Id Current	Displays the d-axis current for the motor at the previous fault.	No signal output available	0.10%

## B.13 U: Monitors

No. (Addr. Hex)	Name	Description	Analog Output Level	Unit
U2-20 (8E)	Heatsink Temperature at Previous Fault Actual Fin Temp	Displays the temperature of the heatsink when the most recent fault occurred.	No signal output available	1 °C
U2-27 (07FA)	Motor Temperature at Previous Fault (NTC) Motor Temp (NTC)	Displays the temperature of the motor when the most recent fault occurred.	No signal output available	–
U2-30 (3008)	Date Year at Previous Fault Date Year YYYY	Displays the year when the most recent fault occurred.	No signal output available	–
U2-31 (3009)	Date Month and Day at Previous Fault Date Mo Day MMDD	Displays the date and day when the most recent fault occurred.	No signal output available	–
U2-32 (300A)	Time Hours and Minutes at Previous Fault Time Hr Min HHMM	Displays the time when the most recent fault occurred.	No signal output available	–

<1> The number of decimal places in the parameter value depends on the drive model. *Refer to Defaults by Drive Model on page 372* for details.

<2> When reading the value of this monitor via MEMOBUS/Modbus, a value of 8192 is equal to 100% of the drive rated output current.

## ◆ U3: Fault History

No. (Addr. Hex)	Name	Description	Analog Output Level	Unit
U3-01 to U3-04 (90 to 93 (800 to 803))	First to 4th Most Recent Fault ( Fault Message □)	Displays the first to the fourth most recent faults.	No signal output available	–
U3-05 to U3-10 (804 to 809)	5th to 10th Most Recent Fault ( Fault Message □)	Displays the fifth to the tenth most recent faults. After ten faults, data for the oldest fault is deleted. The most recent fault appears in U3-01, with the next most recent fault appearing in U3-02. The data is moved to the next monitor parameter each time a fault occurs.	No signal output available	–
U3-11 to U3-14 (94 to 97 (80A to 80D))	Cumulative Operation Time at 1st to 4th Most Recent Fault ( Elapsed Time □).	Displays the cumulative operation time when the first to the fourth most recent faults occurred.	No signal output available	1 h
U3-15 to U3-20 (80E to 813)	Cumulative Operation Time at 5th to 10th Most Recent Fault ( Elapsed Time □).	Displays the cumulative operation time when the fifth to the tenth most recent faults occurred.	No signal output available	1 h
U3-21 (300B)	Date Year at Most Recent Fault Fault 1 YYYY	Displays the year when the most recent fault occurred.	No signal output available	–
U3-22 (300C)	Date Month and Day at Most Recent Fault Fault 1 MMDD	Displays the date and day when the most recent faults occurred.	No signal output available	–
U3-23 (300D)	Time Hours and Minutes at Most Recent Fault Fault 1 HHMM	Displays the time when the most recent fault occurred.	No signal output available	–
U3-24 (300E)	Date Year at 2nd Most Recent Fault Fault 2 YYYY	Displays the year when the second most recent fault occurred.	No signal output available	–
U3-25 (300F)	Date Month and Day at 2nd Most Recent Fault Fault 2 MMDD	Displays the date and day when the second most recent fault occurred.	No signal output available	–
U3-26 (3010)	Time Hours and Minutes at 2nd Most Recent Fault Fault 2 HHMM	Displays the time when the second most recent fault occurred.	No signal output available	–
U3-27 (3011)	Date Year at 3rd Most Recent Fault Fault 3 YYYY	Displays the year when the most third recent fault occurred.	No signal output available	–

No. (Addr. Hex)	Name	Description	Analog Output Level	Unit
U3-28 (3012)	Date Month and Day at 3rd Most Recent Fault Fault 3 MMDD	Displays the date and day when the third most recent fault occurred.	No signal output available	–
U3-29 (3013)	Time Hours and Minutes at 3rd Most Recent Fault Fault 3 HHMM	Displays the time when the third most recent fault occurred.	No signal output available	–
U3-30 (3014)	Date Year at 4th Most Recent Fault Fault 4 YYYY	Displays the year when the fourth most recent fault occurred.	No signal output available	–
U3-31 (3015)	Date Month and Day at 4th Most Recent Fault Fault 4 MMDD	Displays the date and day when the fourth most recent fault occurred.	No signal output available	–
U3-32 (3016)	Time Hours and Minutes at 4th Most Recent Fault Fault 4 HHMM	Displays the time when the fourth most recent fault occurred.	No signal output available	–
U3-33 (3017)	Date Year at 5th Most Recent Fault Fault 5 YYYY	Displays the year when the fifth most recent fault occurred.	No signal output available	–
U3-34 (3018)	Date Month and Day at 5th Most Recent Fault Fault 5 MMDD	Displays the date and day when the fifth most recent fault occurred.	No signal output available	–
U3-35 (3019)	Time Hours and Minutes at 5th Most Recent Fault Fault 5 HHMM	Displays the time when the fifth most recent fault occurred.	No signal output available	–
U3-36 (301A)	Date Year at 6th Most Recent Fault Fault 6 YYYY	Displays the year when the sixth most recent fault occurred.	No signal output available	–
U3-37 (301B)	Date Month and Day a 6th Most Recent Fault Fault 6 MMDD	Displays the date and day when the sixth most recent fault occurred.	No signal output available	–
U3-38 (301C)	Time Hours and Minutes at 6th Most Recent Fault Fault 6 HHMM	Displays the time when the most sixth recent fault occurred.	No signal output available	–
U3-39 (301D)	Date Year at 7th Most Recent Fault Fault 7 YYYY	Displays the year when the most seventh recent fault occurred.	No signal output available	–
U3-40 (301E)	Date Month and Day at 7th Most Recent Fault Fault 7 MMDD	Displays the date and day when the seventh most recent fault occurred.	No signal output available	–
U3-41 (301F)	Time Hours and Minutes at 7th Most Recent Fault Fault 7 HHMM	Displays the time when the seventh most recent fault occurred.	No signal output available	–
U3-42 (3020)	Date Year at 8th Most Recent Fault Fault 8 YYYY	Displays the year when the eighth most recent fault occurred.	No signal output available	–
U3-43 (3021)	Date Month and Day 8th at Most Recent Fault Fault 8 MMDD	Displays the date and day when the eighth most recent fault occurred.	No signal output available	–
U3-44 (3022)	Time Hours and Minutes at 8th Most Recent Fault Fault 8 HHMM	Displays the time when the eighth most recent fault occurred.	No signal output available	–
U3-45 (3023)	Date Year at 9th Most Recent Fault Fault 9 YYYY	Displays the year when the ninth most recent fault occurred.	No signal output available	–
U3-46 (3024)	Date Month and Day at 9th Most Recent Fault Fault 9 MMDD	Displays the date and day when the ninth most recent fault occurred.	No signal output available	–
U3-47 (3025)	Time Hours and Minutes at 9th Most Recent Fault Fault 9 HHMM	Displays the time when the ninth most recent fault occurred.	No signal output available	–

## B.13 U: Monitors

No. (Addr. Hex)	Name	Description	Analog Output Level	Unit
U3-48 (3026)	Date Year at 10th Most Recent Fault Fault 10 YYYY	Displays the year when the tenth most recent fault occurred.	No signal output available	–
U3-49 (3027)	Date Month and Day at 10th Most Recent Fault Fault 10 MMDD	Displays the date and day when the tenth most recent fault occurred.	No signal output available	–
U3-50 (3028)	Time Hours and Minutes at 10th Most Recent Fault 10 HHMM	Displays the time when the tenth most recent fault occurred.	No signal output available	–

## ◆ U4: Maintenance Monitors

No. (Addr. Hex)	Name	Description	Analog Output Level	Unit
U4-01 (4C)	Cumulative Operation Time Drv Elapsed Time	Displays the cumulative operation time of the drive. The value for the cumulative operation time counter can be reset in parameter o4-01. Use parameter o4-02 to determine if the operation time should start as soon as the power is switched on or only while the Run command is present. The maximum number displayed is 65535.  <b>Note:</b> This monitor is only updated every 10 operating hours.	No signal output available	1 h
U4-02 (75)	Number of Run Commands RUN Cmd Counter	Displays the number of times the Run command is entered. Reset the number of Run commands using parameter o4-13. This value will reset to 0 and start counting again after reaching 65535.	No signal output available	1 Time
U4-03 (67)	Cooling Fan Operation Time Fan Elapsed Time	Displays the cumulative operation time of the cooling fan. The default value for the fan operation time is reset in parameter o4-03. The maximum number displayed is 65535.  <b>Note:</b> This monitor is only updated every 10 operating hours.	No signal output available	1 h
U4-04 (7E)	Cooling Fan Maintenance Fan Life Mon	Displays main cooling fan usage time as a percentage of its expected performance life. Parameter o4-03 can be used to reset this monitor.	No signal output available	1%
U4-05 (7C)	Capacitor Maintenance Cap Life Mon	Displays main circuit capacitor usage time as a percentage of their expected performance life. Parameter o4-05 can be used to reset this monitor.	No signal output available	1%
U4-06 (07D6)	Soft Charge Bypass Relay Maintenance ChgCirc Life Mon	Displays the soft charge bypass relay maintenance time as a percentage of its estimated performance life. Parameter o4-07 can be used to reset this monitor.	No signal output available	1%
U4-07 (07D7)	IGBT Maintenance IGBT Life Mon	Displays IGBT usage time as a percentage of the expected performance life. Parameter o4-09 can be used to reset this monitor.	No signal output available	1%
U4-08 (68)	Heatsink Temperature Heatsink Temp	Displays the heatsink temperature.  <b>Note:</b> This monitor reports the correct value only when the drive is running.	10 V: 100 °C	1 °C
U4-09 (5E)	LED Check LED Oper Check	Lights all segments of the LED to verify that the display is working properly.	No signal output available	–
U4-10 (5C)	kWh, Lower 4 Digits kWh Lower 4 dig	Monitors the drive output power. The value is shown as a 9-digit number displayed across two monitor parameters, U4-10 and U4-11. Example: 12345678.9 kWh is displayed as: U4-10: 678.9 kWh U4-11: 12345 MWh	No signal output available	1 kWh
U4-11 (5D)	kWh, Upper 5 Digits kWh Upper 5 dig		No signal output available	1 MWh
U4-13 (7CF)	Peak Hold Current Current PeakHold	Displays the highest current value that occurred during run.	No signal output available	0.01 A </>
U4-14 (7D0)	Peak Hold Output Frequency Freq@1 PeakHold	Displays the output frequency when the current value shown in U4-13 occurred.	No signal output available	0.01 Hz
U4-16 (7D8)	Motor Overload Estimate (oL1) Motor OL1 Level	Shows the value of the motor overload detection accumulator. 100% is equal to the oL1 detection level.	10 V: 100%	0.1%



No. (Addr. Hex)	Name	Description	Analog Output Level	Unit
U4-18 (7DA)	Frequency Reference Source Selection Reference Source	Displays the source for the frequency reference as XY-nn. <b>X: indicates which reference is used:</b> 0 = OFF 1 = AUTO 2 = HAND <b>Y-nn: indicates the reference source</b> 0-01 = HOA keypad 1-00 = Analog (not assigned) 1-01 = Analog (terminal A1) 1-02 = Analog (terminal A2) 2-02 to 17 = Multi-step speed (d1-02 to 17) 3-01 = MEMOBUS/Modbus communications 4-01 = Communication option card 9-01 = Up/Down	No signal output available	–
U4-19 (7DB)	Frequency Reference from MEMOBUS/Modbus Comm. MEMOBUS Freq Ref	Displays the frequency reference provided by MEMOBUS/Modbus (decimal).	No signal output available	0.01%
U4-20 (7DC)	Option Frequency Reference Option Freq Ref	Displays the frequency reference input by an option card (decimal).	No signal output available	–
U4-21 (7DD)	Run Command Source Selection Run Cmd Source	Displays the source for the Run command as XY-nn. <b>X: Indicates which Run source is used:</b> 0 = OFF 1 = AUTO 2 = HAND <b>Y: Input power supply data</b> 0 = HOA keypad 1 = External terminals 3 = BACnet or MEMOBUS/Modbus communications 4 = Communication option card <b>nn: Run command limit status data</b> 00: No limit status. 01: Run command was left on when stopped in the PRG mode 02: Run command was left on when switching from LOCAL to REMOTE operation 03: Waiting for soft charge bypass contactor after power up (Uv or Uv1 flashes after 10 s) 04: Waiting for “Run command prohibited” time period to end 05: Fast Stop (digital input, HOA keypad) 06: b1-17 (Run command given at power-up) 07: During baseblock while coast to stop with timer 08: Frequency reference is below minimal reference during baseblock 09: Waiting for Enter command	No signal output available	–
U4-22 (7DE)	MEMOBUS/Modbus Communications Reference MEMOBUS Ref Reg	Displays the drive control data set by MEMOBUS/Modbus communications register no. 0001H as a four-digit hexadecimal number.	No signal output available	–
U4-23 (7DF)	Communication Option Card Reference Option Ref Reg	Displays drive control data set by an option card as a four-digit hexadecimal number.	No signal output available	–

<1> When reading the value of this monitor via MEMOBUS/Modbus, a value of 8192 is equal to 100% of the drive rated output current.

### ◆ U5: PI Monitors

No. (Addr. Hex)	Name	Description	Analog Output Level	Unit
U5-01 (57)	PI Feedback PI Feedback 1	Displays the PI feedback value.	10 V: 100%	0.01%
U5-02 (63)	PI Input PI Input	Displays the amount of PI input (deviation between PI setpoint and feedback).	10 V: 100%	0.01%
U5-03 (64)	PI Output PI Output	Displays PI control output.	10 V: 100%	0.01%
U5-04 (65)	PI Setpoint PI Setpoint	Displays the PI setpoint.	10 V: 100%	0.01%

Parameter List

**B**

## B.13 U: Monitors

No. (Addr. Hex)	Name	Description	Analog Output Level	Unit
U5-05 (7D2)	PI Differential Feedback PI Feedback 2	Displays the second PI feedback value if differential feedback is used (H3-□□ = 16).	10 V: 100%	0.01%
U5-06 (7D3)	PI Adjusted Feedback PI Diff Fdbk	Displays the difference of both feedback values if differential feedback is used (U5-01 - U5-05). If differential feedback is not used, then U5-01 and U5-06 will be the same.	10 V: 100%	0.01%
U5-30 (3000)	Time Hr Min HHMM Time Hr Min HHMM	Displays the current time (Hours and Minutes).	No signal output available	1
U5-31 (3001)	Date Year Date Year	Displays the current year.	No signal output available	1
U5-32 (3002)	Date Mo Day MMDD Date Mo Day MMDD	Displays the current date (Month and Day).	No signal output available	1
U5-33 (3003)	Date Week 000W Date Week	Displays the current date of the week. 0: Sunday 0: Sunday 1: Monday 1: Monday 2: Tuesday 2: Tuesday 3: Wednesday 3: Wednesday 4: Thursday 4: Thursday 5: Friday 5: Friday 6: Saturday 6: Saturday	No signal output available	1

## ◆ U6: Operation Status Monitors

No. (Addr. Hex)	Name	Description	Analog Output Level	Unit
U6-80 to U6-83 (07B0 to 07B3)	Online IP Address	IP Address currently available; U6-80 is the most significant octet.	No signal output available.	-
U6-84 to U6-87 (07B4 to 07B7)	Online IP Address	Subnet currently available; U6-84 is the most significant octet.	No signal output available.	-
U6-88 to U6-91 (07B8 to 07F1)	Online Gateway	Gateway currently available; U6-88 is the most significant octet.	No signal output available.	-
U6-92 (07F2)	Online Gateway	Link Speed	10: 10 Mbps 100: 100 Mbps .	-
U6-93 (07F3)	Online Gateway	Duplex Setting	0: Half 1: Full .	-
U6-98 (07F8)	Online Gateway	First Option Fault	-	-
U6-99 (07F9)	Current Fault	Current Option Fault	-	-

**Note:** Available in bypass controller software versions VST800400 and later.

## B.14 Z: Bypass Parameters

### ◆ Z1: Bypass Control System

No. (Addr. Hex)	Name	LCD Display	Description	Values	Page
Z1-01 (85C6) <span style="border: 1px solid black; padding: 1px;">RUN</span>	Initialize	Initialize 0: No init 1: Set All Def 2: Set Byp Def 3: Set Drv Def	0: No Initialize 1: Set all parameters to their default values. For drive parameters, first issues two-wire reset, then sets individual parameter default values. 2: Set only Bypass Controller parameters to their default values. 3: Set only Drive Controller parameters to their default values. First issues two-wire reset, then sets individual parameter default values.	Default: 0 Range: 0 to 3	196
Z1-02 (85C7) <span style="border: 1px solid black; padding: 1px;">RUN</span>	Password	Password	Allows and restricts access to all parameters. Setting this value equal to the value in Z1-03 toggles access to all parameter settings except this parameter. If the value entered to Z1-02 matches the value entered to Z1-03, the access to all parameters is denied or granted.	Default: — Min.: — Max.: —	196
Z1-03 (85C8) <span style="border: 1px solid black; padding: 1px;">RUN</span>	Password Change	Password Change <5>	The value entered here is the password.	Default: 0 Min.: 0 Max.: 9999	196
Z1-05 (85CA) <span style="border: 1px solid black; padding: 1px;">RUN</span>	Auto Transfer to Bypass Upon Drive Fault	Auto Xfr Byp Flt	When the drive is running and a drive fault occurs, operation will switch to Bypass mode. When the fault is cleared, operation will switch back to Drive mode 0: Disable 1: Enable	Default: 0 Range: 0, 1	196
Z1-06 (85CB) <span style="border: 1px solid black; padding: 1px;">RUN</span>	Power-Up Mode	Power Up Mode <5>	Determines the mode of the Bypass Control upon power-up. 0: OFF 1: AUTO-DRIVE 2: HAND-DRIVE 3: AUTO-BYPASS 4: HAND-BYPASS	Default: 0 Range: 0 to 4	196
Z1-07 (85CC) <span style="border: 1px solid black; padding: 1px;">RUN</span>	Speed Reference Select	Freq Ref Select <5>	Determines the source of the Frequency Reference sent from the Bypass Controller to the Drive. 0: Operator 1: Analog Input 2: Bypass Serial 3: Option Board (CN5)	Default: 1 <5> Range: 0 to 3	197
Z1-08 (85CD) <span style="border: 1px solid black; padding: 1px;">RUN</span>	Run Command Select	Run Command Sel <5>	Determines the source of the Auto Mode Run command used by the Bypass Controller. 0: Operator 1: Bypass Controller Digital Input 2: Bypass Serial 3: Option Board (CN5)	Default: 1 Range: 0 to 3	198
Z1-09 (85CE) <span style="border: 1px solid black; padding: 1px;">RUN</span>	HAND Mode Drive Speed Reference	HandMode FreqRef <5>	This is the speed reference used when the Drive is running in HAND mode. Units are in Hz.	Default: 10.0 Hz <5> Min.: 0.0 Max.: 60.0	198
Z1-10 (85CF) <span style="border: 1px solid black; padding: 1px;">RUN</span>	Smoke Purge Preset Frequency Reference	Smoke Purge Fref <5>	Sets the speed at which the drive will run when the Smoke Purge Drive input is active.	Default: 60.0 Hz <5> Min.: 0.0 Max.: 60.0	199

## B.14 Z: Bypass Parameters

No. (Addr. Hex)	Name	LCD Display	Description	Values	Page
Z1-11 (85D0) <input type="checkbox"/> RUN	2-Motor AND/OR Function Select	2-Mtr AND/OR Sel	0: Disabled (ignore digital inputs) 1: Always use only motor 1 2: Always use only motor 2 3: Always use motors 1 AND 2 4: OR function motor selected by digital input in HAND and AUTO modes 5: OR function use motor 1 in HAND mode and motor selected by digital input in AUTO mode 6: OR function use motor 2 in HAND mode and motor selected by digital input in AUTO mode 7: AND/OR function motor selected (1, 2, or both) by (2) digital inputs in HAND and AUTO mode 8: AND/OR function use motor 1 in HAND mode and motor selected (1, 2, or both) by (2) digital inputs in AUTO mode 9: AND/OR function use motor 2 in HAND mode and motor selected (1, 2, or both) by (2) digital inputs in AUTO mode 10: AND/OR function use motors 1 AND 2 in HAND mode and motor selected (1, 2, or both) by (2) digital inputs in AUTO mode	Default: 0 Range: 0 to 10	199
Z1-12 (85D1) <input type="checkbox"/> RUN	Run Delay Time	Run Delay Time	Delays the drive or bypass Run from when commanded (after RUN, RUN ENABLE, and RUN INTERLOCK are all asserted).	Default: 0.0 s Min.: 0.0 Max.: 300.0	199
Z1-13 (85D2) <input type="checkbox"/> RUN	Pre-Interlock Run Select	Pre Int Run Sel	Allows running at a preset speed starting immediately upon a Run command, ignoring the BAS Interlock Input. The drive frequency reference stays at this preset speed until the Run Delay time (Z1-12) times out. 0: Disabled 1: Enable delay time only	Default: 0 Range: 0, 1	199
Z1-14 (85D3) <input type="checkbox"/> RUN	Run Delay Frequency Reference	Run Delay Fref	Frequency used while delaying the Run command.	Default: 60.0 Hz Min.: 0.0 Max.: 60.0	199
Z1-15 (85D4) <input type="checkbox"/> RUN	Interlock Wait Time	InterlkWait Time <>	Upon entering a Run command, the damper actuator output will be asserted. When an input is programmed for Interlock and the time set to this parameter is reached before the Interlock input goes active, a fault will be declared. A setting of 0.0 will never time out.	Default: 0.0 s Min.: 0.0 Max.: 300.0	200
Z1-16 (85D5)	Energy Savings Mode Enable	Engy Savings En	0: Disable 1: Enable (Freq) 2: Enable (Freq + Cur)  <b>Note:</b> Energy Savings will not function if the motor is running in reverse.	Default: 0 Range: 0 to 2	203
Z1-17 (85D6) <input type="checkbox"/> RUN	Energy Savings Mode Frequency	Energy Freq	Sets the value of the drive frequency reference for use in comparison to enter or exit Energy Savings mode.	Default: 60.0 Hz Min.: 0.0 Max.: 60.0	203
Z1-18 (85D7) <input type="checkbox"/> RUN	Energy Savings Mode Output Current Level	Energy Iout Lvl	Allows system to switch when the output current rises above this level of motor rated current for time specified in Energy Time.	Default: 0.0% Min.: 0.0 Max.: 100.0	203
Z1-19 (85D8) <input type="checkbox"/> RUN	Energy Savings Mode Frequency Reference Deadband	Engy Fref Dbnd	Sets the tolerance around the drive frequency reference value during comparisons to enter or exit Energy Savings mode	Default: 0.5 Hz Min.: 0.0 Max.: 5.0	203
Z1-20 (85D9) <input type="checkbox"/> RUN	Energy Savings Mode Output Frequency Deadband	Energy Freq Dbnd	Sets the tolerance around the drive output frequency value during comparisons to enter or exit Energy Savings mode.	Default: 0.5 Hz Min.: 0.0 Max.: 5.0	204
Z1-21 (85DA) <input type="checkbox"/> RUN	Energy Savings Mode Output Current Deadband	Energy Iout Dbnd	Sets the tolerance around the drive output current value during comparisons to enter or exit Energy Savings mode as a percentage of motor rated current.	Default: 15.0% Min.: 0.0 Max.: 30.0	204
Z1-22 (85DB) <input type="checkbox"/> RUN	Energy Savings Mode Time	Energy Time	Sets the time that the drive frequency reference and drive output frequency must be within the set limits before transferring to Energy Savings mode.	Default: 30 s Min.: 10 Max.: 60000	204

No. (Addr. Hex)	Name	LCD Display	Description	Values	Page
Z1-23 (85DC) RUN	Energy Savings Mode Frequency Reference Increase	Energy Fref Incr	Sets the value to add to the drive Frequency Reference when starting the transfer to bypass mode the drive when entering the Energy Savings Mode.	Default: 6.0 Hz Min.: 0.0 Max.: 10.0	204
Z1-24 (85DD) RUN	Contactor Open Delay Time	Kx Open Delay	Sets the time to delay after commanding the drive output contactor K2 or bypass contactor K3 or 2-Motor OR/AND contactors K4 and K5 to open to allow the contacts to open.	Default: 0.2 s Min.: 0.0 Max.: 5.0	204
Z1-25 (85DE) RUN	Contactor Close Delay Time	Kx Close Delay	Sets the time to delay after commanding the drive output contactor K2 or bypass contactor K3 or 2-Motor OR/AND contactors K4 and K5 to close to allow the contacts to close.	Default: 0.2 s Min.: 0.0 Max.: 5.0	204
Z1-27 (08E0) RUN	Phase Loss Brownout Voltage Level	PL Brownout Volt <=>	Sets the voltage level below which is considered a brownout condition.	Default: 98 V Min.: 0 Max.: 150	204
Z1-28 (85E1) RUN	Phase Loss Brownout Detection Time PL Brownout T	PL Brownout Time <=>	Sets the time that the input voltage is continuously measured to be below the Brownout Voltage level before declaring a Brownout fault.	Default: 3.0 s Min.: 0.0 Max.: 300.0	205
Z1-29 (85E2) RUN	Phase Loss Blackout Voltage Level	PL Blackout Volt <=>	Sets the voltage level below which is considered a blackout condition. When the input voltage is measured below this level, a Blackout fault will be declared.	Default: 0 V Min.: 0 Max.: 150	205
Z1-30 (85E3) RUN	EF0 Fault Delay Time	EF0 FltDly Time <=>	Sets the time between declaring a drive fault and opening the drive and bypass contactors.	Default: 1.0 s Min.: 0.0 Max.: 300.0	205
Z1-31 (85E4) RUN	Loss of Load Detection Enable	Loss of Load En 0: Disable 1: Enable Fault 2: Enable Alarm	0: Disable 1: Enable and declare fault. 2: Enable and alarm only	Default: 0 Range: 0 to 2	205
Z1-32 (85E5) RUN	Loss of Load Drive Frequency	Load Drive Freq	Sets the value to which the drive output frequency must be equal to or greater than for the drive to detect a loss of load.	Default: 60.0 Hz <=> Min.: 0.0 Max.: 60.0	205
Z1-33 (85E6) RUN	Loss of Load Drive Output Current	Load Drive Curr	The drive output current must be equal to or less than this value to detect a loss of load.	Default: 0.0 A Min.: 0.0 Max.: 999.9	205
Z1-34 (85E7) RUN	Loss of Load Drive Time	Load Drive Time	The conditions must be met for the length of time entered here before detecting a loss of load while in Drive mode.	Default: 1.0 s Min.: 0.0 Max.: 300.0	205
Z1-35 (85E8) RUN	Loss of Load Bypass Output Current	Load Byp Cur	The motor current must be equal to or less than this value to detect a loss of load.	Default: 0.0 A Min.: 0.0 Max.: 999.9	205
Z1-36 (85E9) RUN	Loss of Load Bypass Time	Load Byp Time	The conditions must be met for the length of time entered to this parameter before detecting a loss of load while in Bypass mode.	Default: 1.0 s Min.: 0.0 Max.: 300.0	205
Z1-37 (85EA) RUN	Set Time	Set Time 0: Normal display 1: Time Setting 2: Reset Time	Changes the LCD display to time setting to set the Real Time Clock. 0: Normal display 1: Displays time and date setting mode 2: Reset time <=>	Default: 0 Range: 0 to 2	206
Z1-38 (85EB) RUN	HOA Source Select	HOA Select 0: Operator 1: Digital Inputs 2: Ser Comm & Opt	0: Operator 1: Digital Inputs 2: Serial Communications	Default: 0 Range: 0 to 2	206
Z1-39 (85EC) RUN	Drive/Bypass Source Select	Drv/Byp Select 0: Operator 1: Digital Inputs 2: Ser Comm & Opt	0: Operator 1: Digital Inputs 2: Serial Communications	Default: 0 Range: 0 to 2	206

## B.14 Z: Bypass Parameters

No. (Addr. Hex)	Name	LCD Display	Description	Values	Page
Z1-40 (85ED) 	Auto Transfer Wait Time	AutoXfr WaitTime <>	If Auto Transfer is enabled and a drive fault is detected, the bypass controller will wait this length of time before switching to bypass.	Default: 0.0 s Min.: 0.0 Max.: 300.0	206
Z1-41 (85EE) <>	Hand Speed Reference Selection	Hand Spd Ref Sel	Selects the frequency reference source when in Hand Mode. 0: Parameter Z1-09 1: Analog	Default: 0 Range: 0, 1	206
Z1-42 (85EF) <>	Bypass Device Type	Byp Device Type	Selects the soft starter device type when used with a bypass. 0: Contactor 1: Soft Starter 2: SftStr Ramp Ctrl	Default: 0 Range: 0 to 2	207
Z1-43 (85F0) <>	Soft Start Time Delay	SoftStr Time Dly	Sets the delay time between closing contactor K3 to energizing the soft starter.	Default: 2.0 s Min.: 0.0 s Max.: 60.0 s	207
Z1-44 (85F1) <>	Soft Start Ramp Down Timeout	SftStr Rmp Dn TO	Sets the maximum wait time for the current to drop below 5% of E2-01 after removing the soft starter Run command. The soft starter digital output turns off if the current does not fall below below 5% of E2-01 within the set time.	Default: 15.0 s Min.: 1.0 s Max.: 60.0 s	207
Z1-50 (85F7) <>	Bypass Unbalanced Current Detection Level	Byp Unbal Level	Sets the current unbalance level between phases when operating in Bypass Mode.	Default: 25.0% Min.: 5.0 Max.: 25.0	207
Z1-51 (85F8) <>	Bypass Unbalance Trip Time Detection Level	Byp Unbal Time	Sets the trip time for an unbalance condition operating in Bypass Mode. <b>Note:</b> Setting this parameter to 0.0 will disable unbalance detection.	Default: 5.0 s Min.: 0.0 Max.: 30.0	208
Z1-52 (85F9) <>	Bypass Phase Rotation	Byp Phs Rotation	Determines the action to take when Bypass Mode phase rotation is incorrect. 0: Disabled 1: Alarm 2: Fault	Default: 0 <4> Range: 0 to 2	208
Z1-53 (85FA) <>	Load Verification Fault Select	Load Verify	Enables and disables verification that the motor is running when commanded to run. 0: Disabled 1: Enabled	Default: 0 Range: 0, 1	208
Z1-54 (85FB) <>	LCD Contrast Control	LCD Contrast	Sets the contrast of the LCD operator display on the bypass.	Default: 3 Range: 1 to 5	209
Z1-55 (85FC) <>	Welded K3 Contactor Fault Select	Welded Contactor	Enables and disables detection of K3 "welded contactor" condition. 0: Disabled 1: Enabled	Default: 0 Range: 0, 1	209
Z1-60 (8601) <6>	Black Out Selection	Black out Selection	Determines the bypass behavior when contactor voltage drops below Z1-29 setting. 0: Fault 1: Restart	Default: 0 Range: 0, 1	210
Z1-61 (8602) <6>	Restart Delay	Restart Delay	Sets the time delay for restart.	Default: 10 s Min.: 10 s Max.: 300 s	210

<1> Default is 0 in bypass controller software versions VST800297 and earlier.

- <2> Values are given in Hz, but actual values are dependent upon unit settings using drive parameters o1-03, o1-09, o1-10, and o1-11.
- <3> Available in bypass controller software versions VST800298 and later.
- <4> Default is 1 in bypass controller software versions VST800299 and earlier.
- <5> Available in bypass controller software versions VST800400 and later.
- <6> Available in bypass controller software versions VST800401 and later.

## ◆ Z2: Bypass Control Input/Output

No. (Addr. Hex)	Name	Description	Values	Page
Z2-01 (8563) <input type="checkbox"/> RUN	Digital Input 1 Function Select	0: Unused (Available for Serial Comms) 3: DRV Multi-Function Input S3 (H1-03 Setting) 4: DRV Multi-Function Input S4 (H1-04 Setting) 5: DRV Multi-Function Input S5 (H1-05 Setting) 6: DRV Multi-Function Input S6 (H1-06 Setting) 7: DRV Multi-Function Input S7 (H1-07 Setting)	Default: 21 Range: 0 to 43	210
Z2-02 (8564) <input type="checkbox"/> RUN	Digital Input 2 Function Select	21: Run (AUTO Mode) 22: Run Enable (Safety) 23: Run Interlock (BAS)	Default: 22 Range: 0 to 43	210
Z2-03 (8565) <input type="checkbox"/> RUN	Digital Input 3 Function Select	24: Remote Transfer to Bypass 25: Smoke Purge Bypass Run to Destruction 26: Smoke Purge Drive Run to Destruction at Smoke Purge Preset Speed (See Z1-10). Bypass controller will stay in this state even if the drive faults or is unavailable.	Default: 23 Range: 0 to 43	210
Z2-04 (8566) <input type="checkbox"/> RUN	Digital Input 4 Function Select	27: Motor OR Select (2-Motor OR function; 0/1 for Motor 1/2. Behavior defined by Z1-11) 28: Motor AND Select (2-Motor AND function; 0/1 for 1/2 motor. If 1 motor, then look to Motor OR input for selected motor. Behavior defined by Z1-11)	Default: 24 Range: 0 to 43	210
Z2-05 (8567) <input type="checkbox"/> RUN	Digital Input 5 Function Select	29: Motor 1 Overload Contact. When input is open, declare an OL Fault, issue an EF0 fault to the drive, delay per EF0 Fault Delay Time (Z1-30), and open Drive Output (K2) and Bypass (K3) contactors. 30: Motor 2 Overload Contact. When input is open, declare an OL Fault, issue an EF0 fault to the drive, delay per EF0 Fault Delay Time (Z130), and open Drive Output (K2) and Bypass (K3) contactors. 31: HAND Select 32: AUTO Select 33: DRIVE/BYPASS Select (0/1 for Drive/Bypass) 34: Fault Reset	Default: 25 Range: 0 to 43	210
Z2-06 (8568) <input type="checkbox"/> RUN	Digital Input 6 Function Select	35: External Fault (EF0) 36: External Fault (EFB) 37: Run Reverse	Default: 0 Range: 0 to 43	210
Z2-07 (8569)	Digital Input 7 Function Select	38: Fire Stat (Safety) <2> 39: Freeze Stat (Safety) <2> 40: Smoke Alarm (Safety) <2>	Default: 0 Range: 0 to 43	210
Z2-08 (856A) <input type="checkbox"/> RUN	Digital Input 8 Function Select	41: Over Pressure (Safety) <2> 42: Low Suction (Safety) <2> 43: Vibration Switch (Safety) <2>	Default: 29 Range: 0 to 43	210
Z2-09 (856B) <input type="checkbox"/> RUN	Digital Input 1 Invert Select	0: Normal. Lack of input signal = OFF 1: Inverted. Lack of input signal = ON	Default: 0 Range: 0, 1	213
Z2-10 (856C) <input type="checkbox"/> RUN	Digital Input 2 Invert Select	0: Normal. Lack of input signal = OFF 1: Inverted. Lack of input signal = ON	Default: 0 Range: 0, 1	213
Z2-11 (856D) <input type="checkbox"/> RUN	Digital Input 3 Invert Select	0: Normal. Lack of input signal = OFF 1: Inverted. Lack of input signal = ON	Default: 0 Range: 0, 1	213
Z2-12 (856E) <input type="checkbox"/> RUN	Digital Input 4 Invert Select	0: Normal. Lack of input signal = OFF 1: Inverted. Lack of input signal = ON	Default: 0 Range: 0, 1	213
Z2-13 (856F) <input type="checkbox"/> RUN	Digital Input 5 Invert Select	0: Normal. Lack of input signal = OFF 1: Inverted. Lack of input signal = ON	Default: 0 Range: 0, 1	213

## B.14 Z: Bypass Parameters

No. (Addr. Hex)	Name	Description	Values	Page
Z2-14 (8570) RUN	Digital Input 6 Invert Select	0: Normal. Lack of input signal = OFF 1: Inverted. Lack of input signal = ON	Default: 0 Range: 0, 1	213
Z2-15 (8571) RUN	Digital Input 7 Invert Select	0: Normal. Lack of input signal = OFF 1: Inverted. Lack of input signal = ON	Default: 0 Range: 0, 1	213
Z2-16 (8572) RUN	Digital Input 8 Invert Select	0: Normal. Lack of input signal = OFF 1: Inverted. Lack of input signal = ON	Default: 0 Range: 0, 1	213
Z2-23 (8579) RUN	Digital Output 7 Function Select	Digital Output 1 Function Select 0: Serial Comm Controlled 1: K1 Drive Input Contactor 2: K2 Drive Output Contactor	Default: 7 Range: 0 to 24; 99	213
Z2-24 (857A) RUN	Digital Output 8 Function Select	3: K3 Bypass Contactor 4: K4 Motor 1 Select 5: K5 Motor 2 Select 6: READY (Drive and Bypass)	Default: 10 Range: 0 to 24; 99	213
Z2-25 (857B) RUN	Digital Output 9 Function Select	7: RUN Active (Drive or Bypass) 8: Drive RUN Active 9: Bypass RUN Active 10: HAND Mode Active	Default: 12 Range: 0 to 24; 99	213
Z2-26 (857C) RUN	Digital Output 10 Function Select	11: OFF Mode Active 12: AUTO Mode Active 13: Drive Mode Selected 14: Bypass Mode Selected 15: Drive or Bypass Fault Active 16: Drive Fault Active 17: Bypass Fault Active 18: Auto Transfer Active 19: Serial RUN Command Active 20: Damper Actuator Output 21: ON Always 22: Loss of Load Detected 23: Run Verify <1> 24: Soft Start Run <2> 99: Not Used	Default: 15 Range: 0 to 24; 99	213
Z2-31 (8581) <1>	Safety Open Message Selection	Sets the fault message displayed when an FB01 fault is triggered. 0: Safety Open 1: Fire Stat 2: Freeze Stat 3: Smoke Alarm 4: Over Pressure 5: Low Suction 6: Vibration Switch	Default: 0 Range: 0 to 6	213

<1> Available in bypass controller software versions VST800298 and VST800299.

<2> Available in bypass controller software versions VST800400 and later.

## ◆ Z3: Bypass Control Communication

No. (Addr. Hex)	Name	Description	Values	Page
Z3-01 (8500) RUN	Serial Communications Protocol Select	Selects the bypass serial communications protocol. 0: Modbus 1: N2 2: P1 3: BACnet	Default: 3 Range: 0 to 3	214
Z3-02 (8501) RUN	Serial Communications Node Address Select	Selects the bypass serial communications node address.	Default: 1 Min.: 0 Max.: 127	215



No. (Addr. Hex)	Name	Description	Values	Page
Z3-03 (8502) <input type="button" value="RUN"/>	Serial Communications Baud Rate Select	Selects the bypass serial communications speed. 0: 1200 bps <2> 1: 2400 bps <2> 2: 4800 bps <2> 3: 9600 bps 4: 19200 bps 5: 38400 bps 6: 57600 bps 7: 76800 bps 8: 115200 bps	Default: 3 Range: 0 to 8	216
Z3-04 (8503) <input type="button" value="RUN"/>	Serial Communications Parity Select	Selects the bypass serial communications parity. 0: No Parity 1: Even Parity 2: Odd Parity	Default: 0 Range: 0 to 2	216
Z3-05 (8504) <input type="button" value="RUN"/>	Serial Communications Fault Select	Selects the action to take when a serial communications fault is detected. 0: Ignore. A serial communications loss will result in no action being taken. 1: Alarm only. 2: Fault with EF0. An EF0 will be sent to the drive. If running in Bypass mode, the bypass contactor will NOT open and the motor will keep running. 3: Fault with EF0 and Open Contactors. An EF0 fault will be sent to the drive and the bypass contactor (K3) will be opened. 4: Alarm and run at preset speed set in Z3-10. Display AL14 alarm on Operator.	Default: 1 Range: 0 to 4	216
Z3-06 (8505) <input type="button" value="RUN"/>	Serial Communications Fault Time Select	Sets the time allowed to elapse since receiving serial communications before triggering a communications fault. A setting of 0.0 will never time out.	Default: 2.0 s Min.: 0.0 Max.: 99.9	216
Z3-07 (8506) <input type="button" value="RUN"/>	Serial Communications Receive to Transmit Wait Time	Sets the time to delay a serial communications response to a serial communications command.	Default: 5 ms Min.: 0 Max.: 99 ms	216
Z3-08 (8507) <input type="button" value="RUN"/>	BACnet Device Object Identifier 0	BACnet only. Sets the least significant word of 22-bit virtual address.	Default: 1 Min.: 0 Max.: FFFF	217
Z3-09 (8508) <input type="button" value="RUN"/>	BACnet Device Object Identifier 1	BACnet only. Sets the most significant word of 22-bit virtual address.	Default: 0 Min.: 0 Max.: 003F	217
Z3-10 (8509) <input type="button" value="RUN"/>	Cable Loss Preset Frequency	When a serial communications fault is detected and Z3-05=4, the resulting value will become the frequency reference.	Default: 0 Min.: 0.0 Hz Max.: 60.0 Hz	217
Z3-11 (850A) <input type="button" value="RUN"/>	Communication Fault Detection Selection	Communication Fault Detection Selection 0: Disabled. Serial communications fault detection is completely disabled. 1: Enabled. Behavior defined by Z3-05.	Default: 1 Range: 0, 1	217
Z3-12 (850B) <1>	Network Digital Input Select	Enables and disables control of the digital inputs over a network. Wiring to the physical digital input is not required. 0: Disable 1: Enable	Default: 0 Range: 0, 1	217
Z3-13 (850C) <3> <4>	BACnet Command Register Retention	Determines whether to restore the frequency reference, bypass command, or both upon the reapplication of power after losing power.  <b>WARNING! Sudden Movement Hazard. Setting this parameter to 2 or 3 will allow the bypass unit to start before receiving a valid network message. Clear all personnel from the drive, motor, and machine area before reapplying power. Failure to comply could result in injury to personnel.</b>  0: Disable 1: Reference Only 2: Run/Stop Only 3: Ref & Run/Stop	Default: 0 Range: 0 to 3	218

<1> Available in bypass controller software versions VST800298 and later.

<2> Selecting settings 0, 1, or 2 will trigger an oPE29 error when using BACnet communication in bypass controller software versions VST800400 and later.

## B.14 Z: Bypass Parameters

<3> Available in bypass controller software versions VST800400 and later.

<4> Parameter is effective only when Z3-01 = 3 (Serial Communications Protocol Select = BACnet), Z1-07 = 2 (Speed Reference Select = Bypass Serial), and/or Z1-08 = 2 (Run Command Select = Bypass Serial).

### ◆ Z4: Bypass Control Option Boards

No. (Addr. Hex)	Name	Description	Values	Page
Z4-01 (8700) <input type="checkbox"/> RUN	IP Address 1	Sets the most significant octet of network static IP address.	Default: 192 Range: 0 to 255	<a href="#">218</a>
Z4-02 (8701) <input type="checkbox"/> RUN	IP Address 2	Sets the second most significant octet of network static IP address.	Default: 168 Range: 0 to 255	<a href="#">218</a>
Z4-03 (8702) <input type="checkbox"/> RUN	IP Address 3	Sets the third most significant octet of network static IP address.	Default: 1 Range: 0 to 255	<a href="#">218</a>
Z4-04 (8703) <input type="checkbox"/> RUN	IP Address 4	Sets the fourth most significant octet of network static IP address.	Default: 20 Range: 0 to 255	<a href="#">218</a>
Z4-05 (8704) <input type="checkbox"/> RUN	Subnet Mask 1	Sets the most significant octet of network static subnet mask.	Default: 255 Range: 0 to 255	<a href="#">218</a>
Z4-06 (8705) <input type="checkbox"/> RUN	Subnet Mask 2	Sets the second most significant octet of network static subnet mask.	Default: 255 Range: 0 to 255	<a href="#">218</a>
Z4-07 (8706) <input type="checkbox"/> RUN	Subnet Mask 3	Sets the third most significant octet of network static subnet mask.	Default: 255 Range: 0 to 255	<a href="#">218</a>
Z4-08 (8707) <input type="checkbox"/> RUN	Subnet Mask 4	Sets the fourth most significant octet of network static subnet mask.	Default: 0 Range: 0 to 255	<a href="#">218</a>
Z4-09 (8708) <input type="checkbox"/> RUN	Gateway IP Address 1	Sets the most significant octet of network gateway address.	Default: 192 Range: 0 to 255	<a href="#">219</a>
Z4-10 (8709) <input type="checkbox"/> RUN	Gateway IP Address 2	Sets the second most significant octet of network gateway address.	Default: 168 Range: 0 to 255	<a href="#">219</a>
Z4-11 (870A) <input type="checkbox"/> RUN	Gateway IP Address 3	Sets the third most significant octet of network gateway address.	Default: 1 Range: 0 to 255	<a href="#">219</a>
Z4-12 (870B) <input type="checkbox"/> RUN	Gateway IP Address 4	Sets the fourth most significant octet of network gateway address.	Default: 1 Range: 0 to 255	<a href="#">219</a>
Z4-13 (870C) <input type="checkbox"/> RUN	IP Address Mode Select	0: User-Defined (Static IP) 1: BOOTP 2: DHCP	Default: 2 Range: 0 to 2	<a href="#">219</a>
Z4-14 (870D) <input type="checkbox"/> RUN	Duplex Select	0: Forced Half Duplex 1: Auto Negotiate Duplex Mode and Communication Speed 2: Forced Full Duplex	Default: 1 Range: 0 to 2	<a href="#">219</a>
Z4-15 (870E) <input type="checkbox"/> RUN	Speed Mode Setting	10: 10 Mbps 100: 100 Mbps	Default: 10 Range: 10, 100	<a href="#">219</a>

No. (Addr. Hex)	Name	Description	Values	Page
Z4-16 (870F) <input type="checkbox"/> RUN	Communication Loss Timeout	Control connection timeout value for detection of communication loss.	Default: 0 s Min.: 0 Max.: 300	219
Z4-17 (8710) <input type="checkbox"/> RUN	Ethernet Speed Scale	AC/DC Drive Object, Instance 1, Attribute 22	Default: 0 Min.: -15 Max.: 15	219
Z4-18 (8711) <input type="checkbox"/> RUN	Ethernet Current Scale	AC/DC Drive Object, Instance 1, Attribute 23	Default: 0 Min.: -15 Max.: 15	219
Z4-19 (8712) <input type="checkbox"/> RUN	Ethernet Torque Scale	AC/DC Drive Object, Instance 1, Attribute 24	Default: 0 Min.: -15 Max.: 15	219
Z4-20 (8713) <input type="checkbox"/> RUN	Ethernet Power Scale	AC/DC Drive Object, Instance 1, Attribute 26	Default: 0 Min.: -15 Max.: 15	219
Z4-21 (8714) <input type="checkbox"/> RUN	Ethernet Voltage Scale	AC/DC Drive Object, Instance 1, Attribute 27	Default: 0 Min.: -15 Max.: 15	219
Z4-22 (8715) <input type="checkbox"/> RUN	Ethernet Time Scale	AC/DC Drive Object, Instance 1, Attribute 28	Default: 0 Min.: -15 Max.: 15	219
Z4-23 to Z4-32 (8716 to 871F) <input type="checkbox"/> RUN	Dynamic Output Assembly Parameters DOA116 1 to DOA116 10	Parameters used in Output Assembly 116	Default: 0 Range: 0 to FFFF	220
Z4-33 to Z4-42 (8720 to 8729) <input type="checkbox"/> RUN	Dynamic Input Assembly Parameters DIA166 1 to DIA166 10	Parameters used in Output Assembly 166	Default: 0 Range: 0 to FFFF	220

## B.15 Defaults by Drive Model

The following tables show parameters and default settings that change with the drive model selection (o2-04).

**Table B.4 208 V Default Settings by Model Selection**

No.	Name	Unit	Default Settings						
			D002 D003 D004 D007 D010	D016	D024	D031	D046	D059	D075
–	<b>Bypass Model Z1B1</b>	–							
<b>o2-04</b>	<b>Drive Model Selection</b>	<b>Hex.</b>	<b>66</b>	<b>68</b>	<b>6A</b>	<b>6B</b>	<b>6D</b>	<b>6E</b>	<b>6F</b>
b3-04	V/f Gain during Speed Search	%	100	100	100	100	100	100	100
b3-06	Output Current 1 during Speed Search	–	0.5	0.5	0.5	0.5	0.5	0.5	0.5
b3-08	Current Control Gain during Speed Search (Speed Estimation Type)	–	0.50	0.50	0.50	0.50	0.50	0.50	0.50
b3-11	Speed Search Method Switching Level (Speed Estimation Type)	–	5.0	5.0	5.0	5.0	5.0	5.0	5.0
C6-02	Carrier Frequency Selection	–	2	2	2	2	2	2	2
E2-01	Motor Rated Current	A	10.60	16.70	24.20	30.80	46.2	59.4	74.8
E2-03	Motor No-Load Current	A	3.00	4.50	5.10	8.00	11.2	15.2	15.7
L2-03	Momentary Power Loss Minimum Baseblock Time	s	0.5	0.6	0.7	0.8	0.9	1	1
L2-05	Undervoltage Detection Level (Uv1)	–	190	190	190	190	190	190	190
L8-02	Overheat Alarm Level	°C	80	80	105	105	110	110	115
L8-06	Input Phase Detection Level	–	16.0	21.0	15.0	18.0	22.0	23.0	24.0
L8-09	Output Ground Fault Detection Selection	–	0	0	0	0	0	0	1
L8-38	Carrier Frequency Reduction	–	2	2	2	2	2	2	2

No.	Name	Unit	Default Settings					
			D088	D114	D143	D169	D211	D273
–	<b>Bypass Model Z1B1</b>	–						
<b>o2-04</b>	<b>Drive Model Selection</b>	<b>Hex.</b>	<b>70</b>	<b>72</b>	<b>73</b>	<b>74</b>	<b>75</b>	<b>76</b>
b3-04	V/f Gain during Speed Search	%	100	80	80	80	80	80
b3-06	Output Current 1 during Speed Search	–	0.5	0.5	0.5	0.5	0.5	0.7
b3-08	Current Control Gain during Speed Search (Speed Estimation Type)	–	0.50	0.50	0.50	0.50	0.50	0.50
b3-11	Speed Search Method Switching Level (Speed Estimation Type)	–	5.0	5.0	5.0	5.0	5.0	5.0
C6-02	Carrier Frequency Selection	–	2	2	2	2	2	2
E2-01	Motor Rated Current	A	88	114	143	169	211	273
E2-03	Motor No-Load Current	A	18.5	21.9	38.2	44.0	45.6	72.0
L2-03	Momentary Power Loss Minimum Baseblock Time	s	1	1.1	1.1	1.2	1.3	1.5
L2-05	Undervoltage Detection Level (Uv1)	–	190	190	190	190	190	190
L8-02	Overheat Alarm Level	°C	115	115	109	109	109	109
L8-06	Input Phase Detection Level	–	24.0	25.0	28.0	26.0	28.0	28.0
L8-09	Output Ground Fault Detection Selection	–	1	1	1	1	1	1
L8-38	Carrier Frequency Reduction	–	2	2	2	2	2	2

Table B.5 480 V Default Settings by Model Selection

No.	Name	Unit	Default Settings					
			B001 B002 B003 B004	B007	B011	B014	B021	B027
–	Bypass Model Z1B1	–						
<b>o2-04</b>	<b>Drive Model Selection</b>	<b>Hex.</b>	<b>94</b>	<b>96</b>	<b>98</b>	<b>99</b>	<b>9A</b>	<b>9C</b>
b3-04	V/f Gain during Speed Search	%	100	100	100	100	100	100
b3-06	Output Current 1 during Speed Search	–	0.5	0.5	0.5	0.5	0.5	0.5
b3-08	Current Control Gain during Speed Search (Speed Estimation Type)	–	0.50	0.50	0.50	0.50	0.50	0.50
b3-11	Speed Search Method Switching Level (Speed Estimation Type)	–	5.0	5.0	5.0	5.0	5.0	5.0
C6-02	Carrier Frequency Selection	–	2	2	2	2	2	2
E2-01	Motor Rated Current	A	4.80	7.60	11.00	14.00	21.0	27.0
E2-03	Motor No-Load Current	A	1.5	2.3	2.6	4	5.6	7.6
L2-03	Momentary Power Loss Minimum Baseblock Time	s	0.5	0.6	0.7	0.8	0.9	1.0
L2-05	Undervoltage Detection Level (Uv1)	–	380	380	380	380	380	380
L8-02	Overheat Alarm Level	°C	75	75	75	95	95	95
L8-06	Input Phase Detection Level	–	14.0	15.0	17.0	24.0	27.0	25.0
L8-09	Output Ground Fault Detection Selection	–	0	0	0	0	0	0
L8-38	Carrier Frequency Reduction	–	2	2	2	2	2	2

No.	Name	Unit	Default Settings						
			B034	B040	B52L	B052	B065	B077	B096
–	Bypass Model Z1B1	–							
<b>o2-04</b>	<b>Drive Model Selection</b>	<b>Hex.</b>	<b>9D</b>	<b>9E</b>	<b>9F or (B0) &lt;1&gt;</b>	<b>9F or (B0) &lt;1&gt;</b>	<b>A1 or (B1) &lt;2&gt;</b>	<b>A2 or (B2) &lt;3&gt;</b>	<b>A3</b>
b3-04	V/f Gain during Speed Search	%	100	100	100	100	100	100	80
b3-06	Output Current 1 during Speed Search	–	0.5	0.5	0.5	0.5	0.5	0.5	0.5
b3-08	Current Control Gain during Speed Search (Speed Estimation Type)	–	0.50	0.50	0.50	0.50	0.50	0.50	0.50
b3-11	Speed Search Method Switching Level (Speed Estimation Type)	–	5.0	5.0	5.0	5.0	5.0	5.0	5.0
C6-02	Carrier Frequency Selection	–	2	2	2	2	2	2	2
E2-01	Motor Rated Current	A	34.0	40.0	52.0	52.0	65.0	77.0	96.0
E2-03	Motor No-Load Current	A	7.8	9.2	10.9	10.9	19.1	22	24
L2-03	Momentary Power Loss Minimum Baseblock Time	s	1.0	1.0	1.1	1.1	1.1	1.2	1.2
L2-05	Undervoltage Detection Level (Uv1)	–	380	380	380	380	380	380	380
L8-02	Overheat Alarm Level	°C	100	100	102	102	102	102	102
L8-06	Input Phase Detection Level	–	30.0	24.0	24.0	24.0	24.0	24.0	25.0
L8-09	Output Ground Fault Detection Selection	–	0	0	1	1	1	1	1
L8-38	Carrier Frequency Reduction	–	2	2	2	2	2	2	2

<1> Set o2-04 to B0 for Z1000 chassis drives with Rev: B in the nameplate model field.

<2> Set o2-04 to B1 for Z1000 chassis drives with Rev: B in the nameplate model field.

<3> Set o2-04 to B2 for Z1000 chassis drives with Rev: B in the nameplate model field.

## B.15 Defaults by Drive Model

No.	Name	Unit	Default Settings				
			B124	B156	B180	B240	B302
–	<b>Bypass Model Z1B1</b>	–	<b>B124</b>	<b>B156</b>	<b>B180</b>	<b>B240</b>	<b>B302</b>
<b>o2-04</b>	<b>Drive Model Selection</b>	<b>Hex.</b>	<b>A4</b>	<b>A5</b>	<b>A6</b>	<b>A7</b>	<b>A9</b>
b3-04	V/f Gain during Speed Search	%	60	60	60	60	60
b3-06	Output Current 1 during Speed Search	–	0.7	0.7	0.7	0.7	0.7
b3-08	Current Control Gain during Speed Search (Speed Estimation Type)	–	0.80	0.80	0.80	0.80	0.80
b3-11	Speed Search Method Switching Level (Speed Estimation Type)	–	5.0	5.0	5.0	5.0	5.0
C6-02	Carrier Frequency Selection	–	2	2	2	2	2
E2-01	Motor Rated Current	A	124.0	156.0	180.0	240.0	302.0
E2-03	Motor No-Load Current	A	36	40	49	58	81
L2-03	Momentary Power Loss Minimum Baseblock Time	s	1.3	1.5	1.7	1.7	1.9
L2-05	Undervoltage Detection Level (Uv1)	–	380	380	380	380	380
L8-02	Overheat Alarm Level	°C	102	112	112	112	111
L8-06	Input Phase Detection Level	–	27.0	23.0	23.0	26.0	25.0
L8-09	Output Ground Fault Detection Selection	–	1	1	1	1	1
L8-38	Carrier Frequency Reduction	–	2	2	2	2	2

# Appendix: C

## BACnet Communications

---

<b>C.1</b>	<b>BACNET CONFIGURATION.....</b>	<b>376</b>
<b>C.2</b>	<b>COMMUNICATION SPECIFICATIONS.....</b>	<b>377</b>
<b>C.3</b>	<b>CONNECTING TO A NETWORK.....</b>	<b>378</b>
<b>C.4</b>	<b>BACNET SETUP PARAMETERS.....</b>	<b>380</b>
<b>C.5</b>	<b>BYPASS OPERATIONS BY BACNET.....</b>	<b>382</b>
<b>C.6</b>	<b>BACNET OBJECTS SUPPORTED.....</b>	<b>383</b>
<b>C.7</b>	<b>ACCESSING BYPASS PARAMETERS AND THE ENTER COMMAND.....</b>	<b>390</b>
<b>C.8</b>	<b>COMMUNICATION ERRORS.....</b>	<b>391</b>
<b>C.9</b>	<b>BACNET PROTOCOL IMPLEMENTATION CONFORMANCE STATEMENT....</b>	<b>392</b>

### C.1 BACnet Configuration

The Z1000 Bypass system can be monitored and controlled by a controller on a Building Automation and Control network (BACnet) using RS-485 technology and MS/TP (Master-Slave/Token-Passing) protocol. The Z1000 Bypass conforms to the BACnet application specific controller (B-ASC) device profile. BACnet MS/TP connection is made to the bypass controller. Parameters and monitors in both the drive and the bypass controller are made accessible from this one connection.

Up to 127 bypasses can communicate on a single BACnet MS/TP network. If more bypasses or BACnet devices are required, then a BACnet router is required to allow another MS/TP network to be available with up to another 127 bypasses.

The BACnet node address is configurable by a parameter in the Z1000 Bypass. This defines the physical address of the bypass on the MS/TP network. In addition, both the Device Object instance ID and the Device Object Name are configurable. These allow the bypass to have a virtual address, and simplify the controller configuration.

Once the addressing is set, a controller can initiate communication to the Z1000 Bypass. The bypass will perform the specified function and then send a response back to the controller. The bypass will usually respond immediately, but may delay its response until it gets the token for commands that may take extra local processing time.

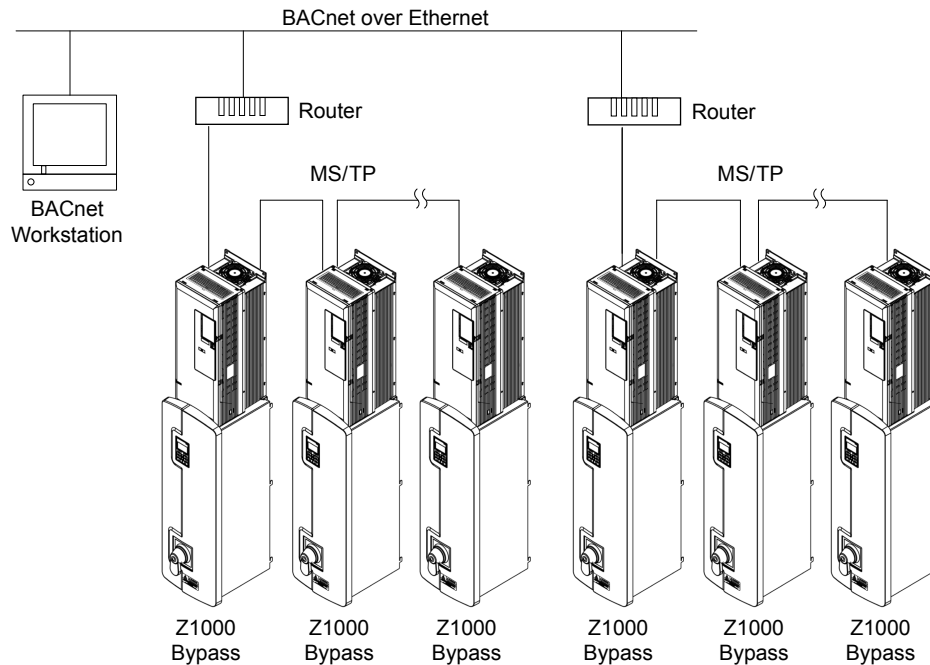

Figure C.1 Connecting Multiple Z1000 Bypasses to a BACnet Workstation



## C.2 Communication Specifications

BACnet specifications appear in the following table:

Item	Specifications
Interface	MS/TP (Master-Slave/Token-Passing) RS-485
Communication Parameters	Communication Speeds: 1200 <1>, 2400 <1>, 4800 <1>, 9600, 19200, 38400, 57600, 76800, 115200 bps
Protocol	BACnet MS/TP
Max Number of Bypasses	127 per MS/TP Network Segment

<1> Selecting these settings will trigger an oPE29 error when using BACNet communication in bypass controller software versions VST800400 and later.

### C.3 Connecting to a Network

This section explains how to connect the Z1000 Bypass to a BACnet network and the network termination required for a connection.

#### ◆ Network Cable Connection

Follow the instructions below to connect the Z1000 Bypass to a BACnet network.

1. With the power shut off, connect the communications cable to the bypass and the master. Use terminal TB3 for BACnet.

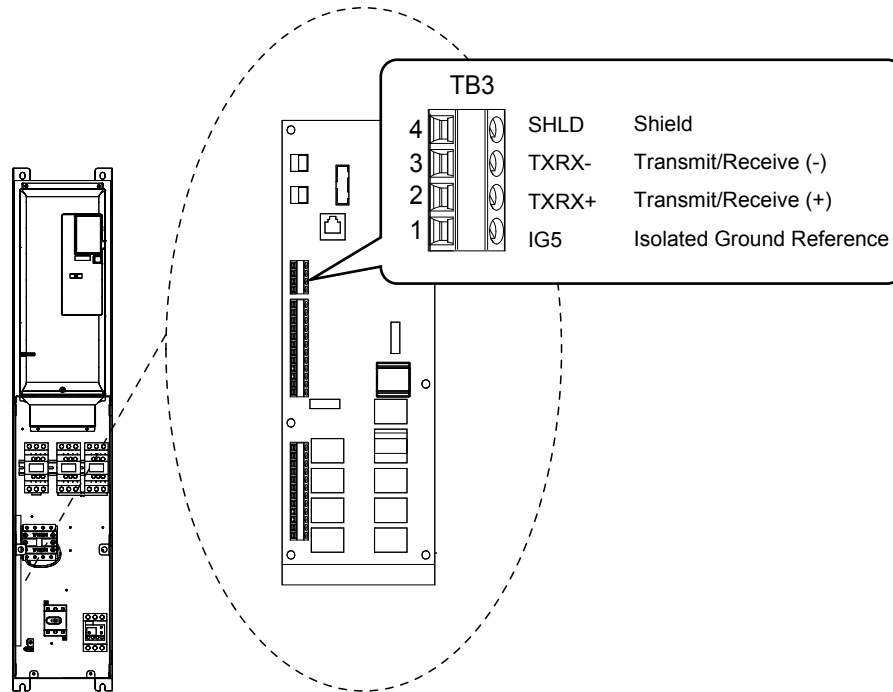

Figure C.2 Serial Communications Cable Connection Terminal (TB3)

**Note:** Separate the communications cables from the main circuit cables and other wiring and power cables. Use shielded cables for the communications cables, and properly shielded clamps to prevent problems caused by electrical interference.

2. Check or set the termination resistor selection at all slaves. Use the description in [Network Termination](#) on page 379 for slaves that are Z1000 Bypasses.
3. Switch the power on.
4. Set the parameters needed for serial communications (Z3-01 through Z3-09) using the digital operator.
5. Shut the power off and wait until the display on the digital operator goes out completely.
6. Turn the power back on.
7. The Z1000 Bypass is now ready to begin communicating with the master.

## ◆ Wiring Diagram for Multiple Connections

Figure C.3 explains the wiring diagrams for multiple connections using BACnet communication.

### ■ MS/TP Interface

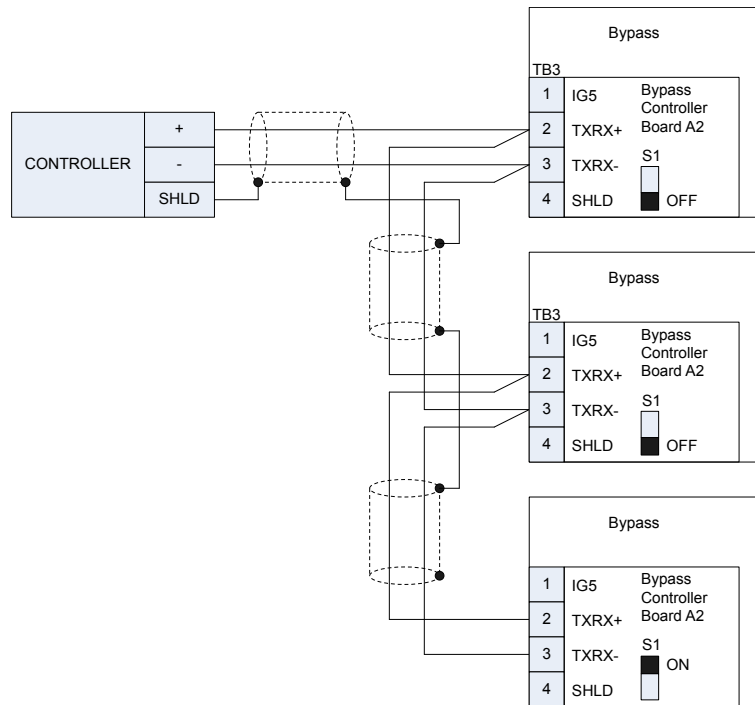

Figure C.3 Connection Diagram for Multiple Connections

**Note:** Turn on DIP switch S1 on the bypass that is located at the end of the network. If S1 is missing, then an external 120 ohm resistor must be placed across terminals TXRX+ and TXRX-. All other slave devices must have this DIP switch set to the OFF position (or if S1 is missing, no external resistor is used).

## ◆ Network Termination

The two ends of the BACnet network line have to be terminated with a 120 ohm resistor between the TXRX+ and TXRX- signals. The Z1000 Bypass has a built in termination resistor that can be enabled or disabled using DIP switch S1. If a bypass is located at the end of a network line, enable the termination resistor by setting DIP switch S1 to the ON position. Disable the termination resistor on all slaves that are not located at the network line end.

**Note:** Some bypass controllers do not have DIP switch S1. If this is the case, then an external 120 ohm resistor must be placed across the TXRX+ and TXRX- signals if the bypass controller is at the end of a network line.

## C.4 BACnet Setup Parameters

### ◆ BACnet Serial Communication

This section describes parameters necessary to set up BACnet communications.

#### ■ Z3-01: Serial Communications Protocol Select

Selects the bypass serial communications protocol.

No.	Name	Setting Range	Default
Z3-01	Serial Communications Protocol Select	0 to 3	3

**Setting 0: Modbus**

**Setting 1: N2**

**Setting 2: P1**

**Setting 3: BACnet**

#### ■ Z3-02: Serial Communications Node Select

Selects the bypass serial communications node address.

**Note:** Each slave must be assigned a unique slave address for serial communications to work properly. Slave addresses do not need to be assigned in sequential order, but no two slaves may share the same address.

No.	Name	Setting Range	Default
Z3-02	Serial Communications Node Select	0 to 127	1

#### ■ Z3-03: Serial Communications Baud Rate Select

Selects the bypass serial communications speed.

Selecting settings 0, 1, or 2 will trigger an oPE29 error when using BACNet communication (Z3-01 = 3) in bypass controller software versions VST800400 and later.

No.	Name	Setting Range	Default
Z3-03	Serial Communications Baud Rate Select	0 to 8	3

**Setting 0: 1200 bps**

**Setting 1: 2400 bps**

**Setting 2: 4800 bps**

**Setting 3: 9600 bps**

**Setting 4: 19200 bps**

**Setting 5: 38400 bps**

**Setting 6: 57600 bps**

**Setting 7: 76800 bps**

**Setting 8: 115200 bps**

#### ■ Z3-05: Serial Communications Fault Select

Selects the action to take when a serial communications fault is detected. A serial communications fault is detected when after last communicating, no communications occurs within the time set to Z3-06.

No.	Name	Setting Range	Default
Z3-05	Serial Communications Fault Select	0 to 4	1

**Setting 0: Ignore**

**Setting 1: Alarm Only**

**Setting 2: Fault with EF0**

An EF0 fault will be sent to the drive.

**Setting 3: Fault with EF0 and Open Contactors**

An EF0 fault will be sent to the drive and the bypass contactor (K3) will be opened.

**Setting 4: Alarm and run at preset speed set in Z3-10**

Display AL14 alarm on operator.

**■ Z3-08, Z3-09: BACnet Device Object Identifier**

These parameters set the Instance Identifier of the BACnet Device Object, where Z3-08 is the least significant word and Z3-09 is the most significant word.

No.	Name	Setting Range	Default
Z3-08	BACnet Device Object Identifier 0	0 to FFFFH	1
Z3-09	BACnet Device Object Identifier 1	0 to 003FH	0

Example 1: Set Device Object Instance Identifier of “1234”.

1234 decimal is equal to 4D2H (hexadecimal).

Set Z3-08 to 4D2H and set Z3-09 to 0.

Example 2: Set Device Object Instance Identifier of “123456”.

123456 decimal is equal to 1E240H.

Set Z3-08 to D687H and set Z3-09 to 12H.

**■ Z3-13: BACnet Command Register Retention**

Refer to [Z3-13: BACnet Command Register Retention](#) description on page 218.

# C.5 Bypass Operations by BACnet

The bypass operations that can be performed by BACnet communication depend on parameter settings. This section explains the functions that can be used and related parameter settings.

### ◆ Observing the Bypass Operation

A controller can perform the following actions with BACnet communications at any time regardless of parameter settings:

- Observe bypass and drive status and control terminal status from a controller
- Read and write parameters
- Set and reset faults
- Set multi-function inputs.

**Note:** Input settings from the input terminals S□ and from BACnet communications are both linked by a logical OR operation.

### ◆ Controlling the Bypass

Select an external reference and adjust the parameters in [Table C.1](#) accordingly to start and stop the drive or set the frequency reference using BACnet communications.

**Table C.1 Setting Parameters for Drive Control from BACnet**

Reference Source	Parameter	Name	Required Setting
External Reference 1	Z1-07	Frequency Reference Select	2
	Z1-08	Run Command Select	2

[Refer to Z1-07: Speed Reference Select on page 197](#) and [Refer to Z1-08: Run Command Select on page 198](#) for details on external reference parameter selections.

## C.6 BACnet Objects Supported

### ◆ Present Value Access

The Present Value (PV) of BACnet objects can always be read. In addition, some PVs can be written or commanded. A commandable PV is similar to writing the value, but the value is actually written into a priority array. The value occupying the highest priority in the array will be used by the bypass. The convention for showing how the PV is accessed is shown in [Table C.2](#) and will be noted for the PV of each object.

Table C.2 Present Value Access Values

PV Access	Name	Description
C	Commandable	Value written to a priority array. The highest priority value in the array is then written to the bypass.
R	Readable	Value is read-only
W	Writable	Value written to the bypass

### ◆ Supported Properties of Objects

Table C.3 Object Properties

Property	Object Type						
	Device	Analog Input	Analog Output	Analog Value	Binary Output	Binary Output	Binary Value
Object_Identifier	Yes	Yes	Yes	Yes	Yes	Yes	Yes
Object_Name	Yes	Yes	Yes	Yes	Yes	Yes	Yes
Object_Type	Yes	Yes	Yes	Yes	Yes	Yes	Yes
System_Status	Yes	–	–	–	–	–	–
Vendor_Name	Yes	–	–	–	–	–	–
Vendor_Identifier	Yes	–	–	–	–	–	–
Model_Name	Yes	–	–	–	–	–	–
Firmware_Revision	Yes	–	–	–	–	–	–
Protocol_Version	Yes	–	–	–	–	–	–
Protocol_Revision	Yes	–	–	–	–	–	–
Protocol_Services_Supported	Yes	–	–	–	–	–	–
Protocol_Object_Types_Supported	Yes	–	–	–	–	–	–
Object_List	Yes	–	–	–	–	–	–
Max_ADPU_Length_Accepted	Yes	–	–	–	–	–	–
Segmentation_Supported	Yes	–	–	–	–	–	–
Local_Time	Yes	–	–	–	–	–	–
Local_Date	Yes	–	–	–	–	–	–
ADPU_Timeout	Yes	–	–	–	–	–	–
Number_Of_ADPU_Retries	Yes	–	–	–	–	–	–
Max_Masters	Yes	–	–	–	–	–	–
Max_Info_Frames	Yes	–	–	–	–	–	–
Device_Address_Binding	Yes	–	–	–	–	–	–
Database_Revision	Yes	–	–	–	–	–	–
Present_Value	–	Yes	Yes	Yes	Yes	Yes	Yes
Status_Flags	–	Yes	Yes	Yes	Yes	Yes	Yes
Event_State	–	Yes	Yes	Yes	Yes	Yes	Yes
Reliability	–	Yes	Yes	Yes	Yes	Yes	Yes
Out_Of_Service	–	Yes	Yes	Yes	Yes	Yes	Yes
Units	–	Yes	Yes	Yes	–	–	–
Priority_Array	–	–	Yes <?>	Yes <?>	–	Yes	Yes
Relinquish_Default	–	–	Yes <?>	Yes <?>	–	Yes	Yes
Polarity	–	–	–	–	Yes	Yes	–

## C.6 BACnet Objects Supported

Property	Object Type						
	Device	Analog Input	Analog Output	Analog Value	Binary Output	Binary Output	Binary Value
Inactive_Text	–	–	–	–	Yes	Yes	Yes
Active_Text	–	–	–	–	Yes	Yes	Yes

<1> For Commandable Object Instances only.

### ◆ Analog Input Objects

Table C.4 Analog Input Objects

Object ID	Object Name	Modbus Address	Precision	Range	Units	PV Access
AI1	Analog Input 1 Level	004EH	XXXX.X	–	%	R
AI2	Analog Input 2 Level	004FH	XXXX.X	–	%	R
AI3	Not used AI3	–	–	–	–	–
AI4	Not used AI4	–	–	–	–	–
AI5	Not used AI5	–	–	–	–	–
AI6	Display Format o1-03	0502H	XXXXX	–	–	R
AI7	Scale Format b5-20	01E2H	XXXXX	–	–	R
AI8	Inverter Model o2-04	0508F	XXXXX	–	–	R
AI9	Rated Current n9-01	05D0H	XXXX.X	–	Amps	R
AI10	Motor Current UB-01	8780H	XXXX.X	–	Amps	R
AI11	Contactors Voltage	8790H	XXXXX	–	Volts	R

### ◆ Analog Output Objects

Table C.5 Analog Output Objects

Object ID	Object Name	Modbus Address	Precision	Range	Units	PV Access
AO1	Analog Output 1 Level	0007H	XXXX.X	0 to 100.0	%	C
AO2	Analog Output 2 Level	0008H	XXXX.X	0 to 100.0	%	C

### ◆ Analog Value Objects

Table C.6 Analog Value Objects

Object ID	Object Name	Modbus Address	Precision	Range	Units	PV Access
AV1	Operation Cmd	0001H	–	–	–	C
AV2	Frequency Cmd	8401H	XXX.XX Depends on o1-03	0.00 to 600.00	Hz Depends on o1-03	C
AV3	PI Setpoint Cmd	0006H	XXX.XX	-100.00 to 100.00	%	C
AV4	MF Output Cmd	0009H	–	–	–	C
AV5	Reference Select Cmd	000FH	–	–	–	C
AV6	Drive Status	0020H	–	–	–	R
AV7	Fault Details	0021H	–	–	–	R
AV8	Data Link Status	0022H	–	–	–	R
AV9	Frequency Reference	0040H	XXX.XX Depends on o1-03	–	Hz Depends on o1-03	R
AV10	Output Frequency	0041H	XXX.XX Depends on o1-03	–	Hz Depends on o1-03	R
AV11	Output Voltage	0045H	XXXX.X	–	Volts	R
AV12	Output Current	0026H	XXXX.X	–	Amps	R



Object ID	Object Name	Modbus Address	Precision	Range	Units	PV Access
AV13	Output Power	0047H	XXXX.X (for drives rated above 11 kVA) XXX.XX (for drives rated 11 kVA or lower)	–	kW	R
AV14	Torque Reference (U1-09)	0048H	XXXX.X	–	%	R
AV15	MF Input Status	002BH	–	–	–	R
AV16	Drive Status 2	002CH	–	–	–	R
AV17	MF Output Status	002DH	–	–	–	R
AV18	DC Bus Voltage	0031H	XXXXX	–	Volts	R
AV19	PI Feedback Level	0038H	XXXX.X	–	%	R
AV20	PI Input Level	0039H	XXXX.X	–	%	R
AV21	PI Output Level	003AH	XXXX.X	–	%	R
AV22	Drive SW Num	004DH	XXXXX	–	–	R
AV23	Bypass SW Num	8791H	XXXXX	–	–	R
AV24	Comm Error Detail	003DH	–	–	–	R
AV25	KVA Setting	003EH	XXXXX	–	–	R
AV26	Control Method	0043H	XXXXX	–	–	R
AV27	Accel Time	0200H	XXXX.X	0.0 to 6000.0	Sec	W
AV28	Decel Time	0201H	XXXX.X	0.0 to 6000.0	Sec	W
AV29 <4>	Parameter Number	–	XXXXX	0 to FFFFH	–	W
AV30 <4>	Parameter Data	–	XXXXX	0 to FFFFH	–	W
AV31	Motor Current	8780H	XXXX.X	–	Amps	R
AV32	120 V to Kx Coils	8790H	XXXXX	–	Volts	R
AV33 <2>	Drive kWh	0x005C and 0x005D	XXXXXXXX.X	0.0 to 32767999.9	kWh	R
AV35 <3>	Drive Run Time	0x004C	XXXX	-	Hours	R
AV36 <3>	Output Freq In %	0x003F	XXX.XX	-	%	R
AV37 <3>	Output Freq In RPM	0x003E	XXXX	-	RPM	R
AV38 <3>	Torque Iq (U6-01)	0x0051	XXX.X	-	%	R
AV39 <3>	Drive HOA Status	0x07DA first digit	X	-	-	R
AV40 <3>	Last Drive Fault <4>	0x0081	XX.XX	-	-	R
AV41 <3>	Last Bypass Fault <5>	0x878C	XXXX	-	-	R
AV41 <3>	Last Bypass Fault	0x878C	XXXX	-	-	R
AV42 <3>	Fault Code <6>	0080H (Drive Fault) or 8788H (Bypass Fault)	XXXXX	-	-	R

<1> Refer to [Accessing Bypass Parameters and the Enter Command on page 390](#) for an explanation of how to read and write drive parameters not listed in the analog or binary objects.

<2> Available in bypass controller software versions VST800298 and later.

<3> Available in bypass controller software versions VST800400 and later.

<4> Refer to [Fault Trace Contents on page 418](#) for details.

<5> Bypass fault is reported by its fault number. Example: This object will report a value of 3 when an FB03 - External Fault Bypass is present.

<6> Drive faults report the drive fault code. Refer to [Fault Trace Contents on page 418](#) for details. Bypass faults report the bypass fault number + 10000. For example: This object will report a value of 10003 when an FB03 - External Fault Bypass is present.

◆ Binary Input Objects

Table C.7 Binary Input Objects

Object ID	Object Name	Modbus Address	Active Text	Inactive Text	PV Access
BI1	Input Terminal 1	002BH:bit 0	ON	OFF	R
BI2	Input Terminal 2	002BH:bit 1	ON	OFF	R
BI3	Input Terminal 3	002BH:bit 2	ON	OFF	R
BI4	Input Terminal 4	002BH:bit 3	ON	OFF	R
BI5	Input Terminal 5	002BH:bit 4	ON	OFF	R
BI6	Input Terminal 6	002BH:bit 5	ON	OFF	R
BI7	Input Terminal 7	002BH:bit 6	ON	OFF	R
BI8	Multi-Function Out 1	0020H:bit 5	ON	OFF	R
BI9	Multi-Function Out 2	0020H:bit 6	ON	OFF	R
BI10	BYP DI-1 STAT	8781H: bit 0	ON	OFF	R
BI11	BYP DI-2 STAT	8781H: bit 1	ON	OFF	R
BI12	BYP DI-3 STAT	8781H: bit 2	ON	OFF	R
BI13	BYP DI-4 STAT	8781H: bit 3	ON	OFF	R
BI14	BYP DI-5 STAT	8781H: bit 4	ON	OFF	R
BI15	BYP DI-6 STAT	8781H: bit 5	ON	OFF	R
BI16	BYP DI-7 STAT	8781H: bit 6	ON	OFF	R
BI17	BYP DI-8 STAT	8781H: bit 7	ON	OFF	R
BI18	BYP DO-1 STAT	8782H: bit 0	ON	OFF	R
BI19	BYP DO-2 STAT	8782H: bit 1	ON	OFF	R
BI20	BYP DO-3 STAT	8782H: bit 2	ON	OFF	R
BI21	BYP DO-4 STAT	8782H: bit 3	ON	OFF	R
BI22	BYP DO-5 STAT	8782H: bit 4	ON	OFF	R
BI23	BYP DO-6 STAT	8782H: bit 5	ON	OFF	R
BI24	BYP DO-7 STAT	8782H: bit 6	ON	OFF	R
BI25	BYP DO-8 STAT	8782H: bit 7	ON	OFF	R
BI26	BYP DO-9 STAT	8783H: bit 0	ON	OFF	R
BI27	BYP DO-10 STAT	8783H: bit 1	ON	OFF	R
BI28 <1>	Drive Fault Status	004BH: bit 7	FAULT	OK	R
BI29 <1>	Drive Alarm Status	004BH: bit 6	ALARM	OK	R
BI30 <1>	Drive or Bypass Alarm	8748H: bit 8	ALARM	OK	R

<1> Available in bypass controller software versions VST800400 and later.

◆ Binary Output Objects

Table C.8 Binary Output Objects

Object ID	Object Name	Modbus Address	Active Text	Inactive Text	PV Access
BO1	MF Output M1-M2	0009H:bit 0	ON	OFF	C
BO2	MF Output M3-M4	0009H:bit 1	ON	OFF	C
BO3	MF Output M5-M6	0009H:bit 2	ON	OFF	C
BO4	Ref Sel: PI Setpoint	000FH:bit 1	ON	OFF	C
BO5	Ref Sel: Term S5 IN	8480H:bit 8	ON	OFF	C
BO6	Ref Sel: Term S6 IN	8480H:bit 9	ON	OFF	C
BO7	Refl Sel: Term S7 IN	8480H:bit 10	ON	OFF	C
BO8	BYP DO-07 COMMAND	8403H:bit 6	ON	OFF	C
BO9	BYP DO-08 COMMAND	8403H:bit 7	ON	OFF	C
B010	BYP DO-09 COMMAND	8403H:bit 8	ON	OFF	C

Object ID	Object Name	Modbus Address	Active Text	Inactive Text	PV Access
B011	BYP DO-10 COMMAND	8403H:bit 9	ON	OFF	C

◆ Binary Value Objects

Table C.9 Binary Value Objects

Object ID	Object Name	Modbus Address	Active Text	Inactive Text	PV Access
BV1	Not Used BV1	–	–	–	–
BV2	Not Used BV2	–	–	–	–
BV3	Ext Fault Cmd	8480H:bit 2	FAULT	OFF	C
BV4	Fault Reset Cmd	8480H:bit 3	RESET	OFF	C
BV5	Not Used BV5	–	–	–	–
BV6	Not Used BV6	–	–	–	–
BV7	MF Input 3 Cmd	8480H:bit 6	ON	OFF	C
BV8	MF Input 4 Cmd	8480H:bit 7	ON	OFF	C
BV9	MF Input 5 Cmd	8480H:bit 8	ON	OFF	C
BV10	MF Input 6 Cmd	8480H:bit 9	ON	OFF	C
BV11	MF Input 7 Cmd	8480H:bit 10	ON	OFF	C
BV12	Set Fault Contact Cmd	0009H:bit 6	ENABLE	OFF	C
BV13	RUN-STOP	0020H:bit 0	RUN	OFF	R
BV14	REV-FWD	0020H:bit 1	REV	FWD	R
BV15	READY	0020H:bit 2	READY	OFF	R
BV16	FAULT	0020H:bit 3	FAULTED	OFF	R
BV17	Data Set Error	0020H:bit 4	ERROR	OFF	R
BV18	Overcurrent – Gnd Flt	0021H:bit 0	OC-GF	OFF	R
BV19	Main Ckt OverVoltage	0021H:bit 1	OV	OFF	R
BV20	Drive OverLoad	0021H:bit 2	OL2	OFF	R
BV21	Drive OverHeat	0021H:bit 3	OH1-OH2	OFF	R
BV22	Fuse Blown	0021H:bit 5	PUF	OFF	R
BV23	PI Feedback Loss	0021H:bit 6	FBL	OFF	R
BV24	External Fault	0021H:bit 7	EF0-EF	OFF	R
BV25	Hardware Error	0021H:bit 8	CPF	OFF	R
BV26	Mtr OvrlD-OvrTorque	0021H:bit 9	OL1-OL3	OFF	R
BV27	OverSpeed	0021H:bit 10	OS-DEV	OFF	R
BV28	Main Ckt UnderVoltage	0021H:bit 11	UV	OFF	R
BV29	MCU Cntl Pwr Sy Err	0021H:bit 12	UV1-2-3	OFF	R
BV30	Output Phase Loss	0021H:bit 13	LF	OFF	R
BV31	Communication Error	0021H:bit 14	CE	OFF	R
BV32	Operator Disconnect	0021H:bit 15	OPR	OFF	R
BV33	Operating	002CH:bit 0	OPERATING	OFF	R
BV34	Zero Speed	002CH:bit 1	ON	OFF	R
BV35	Frequency Agree	002CH:bit 2	ON	OFF	R
BV36	Desired Freq Agree	002CH:bit 3	ON	OFF	R
BV37	Frequency Detect 1	002CH:bit 4	ON	OFF	R
BV38	Frequency Detect 2	002CH:bit 5	ON	OFF	R
BV39	Drv Startup Complete	002CH:bit 6	ON	OFF	R
BV40	Low Voltage Detect	002CH:bit 7	ON	OFF	R
BV41	Base Block	002CH:bit 8	ON	OFF	R
BV42	Frequency Ref Mode	8785H:bit 8	COM	LOCAL	R
BV43	Run Command Mode	8485H:bit 9	COM	LOCAL	R

## C.6 BACnet Objects Supported

Object ID	Object Name	Modbus Address	Active Text	Inactive Text	PV Access
BV44	Over Torque Detect	002CH:bit 11	ON	OFF	R
BV45	Frequency Ref Lost	002CH:bit 12	ON	OFF	R
BV46	Retry Error	002CH:bit 13	ON	OFF	R
BV47	Modbus Comms Error	002CH:bit 14	ON	OFF	R
BV48	Modbus Timeout Error	002CH:bit 15	ON	OFF	R
BV49	CRC Error	003DH:bit 0	ON	OFF	R
BV50	Invalid Data Length	003DH:bit 1	ON	OFF	R
BV51	Parity Error	003DH:bit 3	ON	OFF	R
BV52	Overrun Error	003DH:bit 4	ON	OFF	R
BV53	Framing Error	003DH:bit 5	ON	OFF	R
BV54	Timeout Error	003DH:bit 6	ON	OFF	R
BV55 </>	Parameter Accept	0910H:bit 0	ON	OFF	W
BV56 </>	Parameter Enter	0900H:bit 0	ON	OFF	W
BV57	Drive Comms Error	002CH:bit 15	ON	OFF	R
BV58	BYP Run Fwd CMD	8400H: bit 0	ON	OFF	C
BV59	BYP Run Rev CMD	8400H: bit 1	ON	OFF	C
BV60	Not Used BV60	–	ON	OFF	R
BV61	BYP Xfer to BYP CMD	8400H: bit 3	ON	OFF	C
BV62	BYP Smok Prg BYP CMD	8400H: bit 4	ON	OFF	C
BV63	BYP Smok Prg DRV CMD	8400H: bit 5	ON	OFF	C
BV64	BYP Mtr OR Sel CMD	8400H: bit 6	ON	OFF	C
BV65	BYP Mtr AND Sel CMD	8400H: bit 7	ON	OFF	C
BV66	BYP Drive Select CMD	8400H: bit 9	ON	OFF	C
BV67	BYP Auto Select CMD	8400H: bit 10	ON	OFF	C
BV68	Not Used BV68	8400H: bit 11	ON	OFF	C
BV69	BYP BYPASS Sel CMD	8400H: bit 12	BYP	DRV	C
BV70	BYP Fault Reset CMD	8400H: bit 13	ON	OFF	C
BV71	BYP Ext Fault CMD	8400H: bit 14	ON	OFF	C
BV72 </>	BYP DI-01 Command	8402H: bit 0	ON	OFF	W
BV73 </>	BYP DI-02 Command	8402H: bit 1	ON	OFF	W
BV74 </>	BYP DI-03 Command	8402H: bit 2	ON	OFF	W
BV75 </>	BYP DI-04 Command	8402H: bit 3	ON	OFF	W
BV76 </>	BYP DI-05 Command	8402H: bit 4	ON	OFF	W
BV77 </>	BYP DI-06 Command	8402H: bit 5	ON	OFF	W
BV78 </>	BYP DI-07 Command	8402H: bit 6	ON	OFF	W
BV79 </>	BYP DI-08 Command	8402H: bit 7	ON	OFF	W
BV80	BYP HAND Mode Status	8784H: bit 0	ON	OFF	R
BV81	BYP OFF Mode Status	8784H: bit 1	ON	OFF	R
BV82	BYP AUTO Mode Status	8784H: bit 2	ON	OFF	R
BV83	BYP DRV Mode Status	8784H: bit 3	ON	OFF	R
BV84	BYP BYPASS Mode Stat	8784H: bit 4	ON	OFF	R
BV85	BYP Smk Prg BYP Stat	8784H: bit 5	ACTIVE	OFF	R
BV86	BYP Smk Prg DRV Stat	8784H: bit 6	ACTIVE	OFF	R
BV87	BYP Safety Status	8784H: bit 7	OPEN	CLOSED	R
BV88	BYP BAS Interlk Stat	8785H: bit 0	OPEN	CLOSED	R
BV89	BYP RUN Status	8785H: bit 1	RUN	OFF	R
BV90	BYP Fault Status	8785H: bit 2	FAULT	OFF	R
BV91	BYP Auto Xfer Status	8785H: bit 3	ACTIVE	OFF	R

Object ID	Object Name	Modbus Address	Active Text	Inactive Text	PV Access
BV92	BYP Remote Xfer Stat	8785H: bit 4	ACTIVE	OFF	R
BV93	BYP Energy Save Stat	8785H: bit 5	ACTIVE	OFF	R
BV94	BYP Motor 1 Sel Stat	8785H: bit 6	SELECT	OFF	R
BV95	BYP Motor 2 Sel Stat	8785H: bit 7	SELECT	OFF	R
BV96	BYP Drive Flt Status	8786H: bit 0	FAULT	OFF	R
BV97	BYP Safety Flt Stat	8786H: bit 1	FAULT	OFF	R
BV98	BYP BAS ILock Status	8786H: bit 2	FAULT	OFF	R
BV99	BYP Ext Fault Stat	8786H: bit 3	FAULT	OFF	R
BV100	Not Used BV100	8786H: bit 4	FAULT	OFF	R
BV101	BYP Motor OL Stat	8786H: bit 5	FAULT	OFF	R
BV102	BYP Motor 1 OL Stat	8786H: bit 6	FAULT	OFF	R
BV103	BYP Mtr 2 OL Stat	8786H: bit 7	FAULT	OFF	R
BV104	BYP Input Phase Loss	8787H: bit 0	FAULT	OFF	R
BV105	BYP Drive Comms	8787H: bit 2	FAULT	OFF	R
BV106	BYP Loss Of Load	8787H: bit 5	FAULT	OFF	R
BV107	BYP Option Brd Comms	8787H: bit 3	FAULT	OFF	R

- <1> Refer to [Accessing Bypass Parameters and the Enter Command on page 390](#) for an explanation of how to read and write drive parameters not listed in the analog or binary objects.
- <2> Object is disabled when Z3-12 is set to 0 in bypass controller software versions VST800298 and later.

## ◆ Device Object

The Device Object fully describes the BACnet device to the network. Notable is that the Device Object Instance ID and the Device Object Name are configurable.

The Device Object Instance ID is a unique internetwork-wide numerical value. It is a 22-bit value that can range from 0 to 4,194,303. It is configurable by parameters Z3-08 and Z3-09. Any changes to these parameters will not take effect until the power is cycled to the bypass.

The Device Object Name is a unique internetwork-wide character string. It is a 20-character string. It is writable from the BACnet network. Any new string written will not take effect until the power is cycled to the bypass.

## C.7 Accessing Bypass Parameters and the Enter Command

### ◆ Reading Bypass Parameters

Reading bypass parameters not listed in the analog or digital objects is accomplished using AV29 and AV30 as shown below:

1. In decimal, write the desired Modbus register to AV29.
2. In decimal, read the value at the given register from AV30.

For example, to read the Frequency Reference Upper Limit, read from parameter d2-01.

Parameter d2-01 is located at Modbus register 0289H, which is decimal 649.

Set AV29 to “649”

Read AV30 to get the value.

### ◆ Writing Bypass Parameters

Writing bypass parameters not listed in the analog or digital objects is accomplished using AV29, AV30, and BV55 or BV56 as shown below:

1. In decimal, write the desired Modbus register to AV29.
2. In decimal, write the value to be written into AV30.
3. At this point the value is written to the drive, but the location is pending. If necessary, write in more values this way, then the drive will accept these settings by one of two methods:

Set BV55 to “ON” to move data to active memory.

Set BV56 to “ON” to move data into active memory and save to non-volatile memory.

For example, to enable the loss of load function, write a value of “1” to parameter Z1-31.

Parameter Z1-31 is located at Modbus register 85E4H, which is decimal 34276.

Set AV29 to “34276”

Set AV30 to “1”

Set BV56 to “ON”.

### ◆ Enter Command

Enter Commands are only required when using AV29 and AV30 to access bypass parameters. An Enter command is not required when reading or writing to the other BACnet objects.

When writing parameters to the bypass from a controller using BACnet communications, parameter H5-11 determines if an Enter command must be issued to enable these parameters. This section describes the types and functions of the Enter commands.

#### ■ Enter Command Types

The bypass supports two types of Enter commands as shown in [Table C.10](#).

**Table C.10 Enter Command Types**

BACnet Object	Modbus Address	Description
BV55 (Write “ON”)	0910H (Write 0)	Writes data in the RAM only. Parameter changes are lost when the drive or bypass is shut off.
BV56 (Write “ON”)	0900H (Write 0)	Simultaneously writes data into the EEPROM (non-volatile memory) of the drive or bypass and enables the data in RAM. Parameter changes remain after cycling power.

**Note:** The EEPROM can only be written to 100,000 times, so it is recommended to limit the number of times writing to the EEPROM. The Enter command registers 0900H and 0910H are write-only and if these registers are read, the register address will be invalid. However, BACnet objects BV55 and BV56 can be read without error.

## C.8 Communication Errors

Errors that may occur when accessing drive parameters using the BACnet objects are shown in [Table C.11](#).

**Table C.11 MEMOBUS to BACnet Error Conversion**

Error Code	Description
03d	BN_ERR_DEVICE_IS_BUSY Writing to a parameter was attempted while the drive was saving parameters to non-volatile memory.
27d	BN_ERR_READ_ACCESS_DENIED Invalid parameter register number used when reading.
37d	BN_ERR_VALUE_OUT_OF_RANGE Value written to the parameter is out of the valid range.
40d	BN_ERR_WRITE_ACCESS_DENIED An invalid parameter register number was used when writing. Writing to a parameter was attempted while the drive was in a mode that disables writing (i.e., writing while the drive was Auto-Tuning). Writing to a parameter was attempted while the DC Bus had an Undervoltage (Uv) fault

# C.9 BACnet Protocol Implementation Conformance Statement

Date: 9/19/2011

Vendor Name: Yaskawa America, Inc.

Product Name: VFD Bypass

Product Model Number: UTC00046X

Application Software Version: VST80029x / Firmware Revision: 1.0 / BACnet Protocol Revision: 4

Product Description:

The Yaskawa VFD Bypass is a high performance product specifically designed for commercial building automation applications. The Yaskawa BACnet feature connects the VFD Bypass to a standard BACnet MS/TP network. These products may be fully controlled and monitored over BACnet. All Bypass and drive parameters are available for reading and writing.

BACnet Standardized Device Profile (Annex L):

- BACnet Operator Workstation (B-OWS)
- BACnet Building Controller (B-BC)
- BACnet Advanced Application Controller (B-AAC)
- BACnet Application Specific Controller (B-ASC)
- BACnet Smart Sensor (B-SS)
- BACnet Smart Actuator (B-SA)

List all BACnet Interoperability Building Blocks Supported (Annex K):

- Data Sharing-ReadProperty-B (DS-RP-B)
- Data Sharing-WriteProperty-B (DS-WP-B)
- Device Management-Dynamic Device Binding-B (DM-DDB-B)
- Device Management-Dynamic Object Binding-B (DM-DOB-B)
- Device Management-DeviceCommunicationControl-B (DM-DCC-B)
- Device Management-ReinitializeDevice-B (DM-RD-B)
- Device Management-TimeSynchronization-B (DM-TS-B)

Segmentation Capability:

- Segmented requests supported / Window Size
- Segmented responses supported / Window Size

Standard Object Types Supported:

- Device Object
- Analog Input Object
- Analog Output Object
- Analog Value Object
- Binary Input Object
- Binary Output Object
- Binary Value Object

Data Link Layer Options:

- BACnet IP, (Annex J)
- BACnet IP, (Annex J), Foreign Device
- ISO 8802-3, Ethernet (Clause 7)
- ANSI/ATA 878.1, 2.5 Mb. ARCNET (Clause 8)
- ANSI/ATA 878.1, RS-485 ARCNET (Clause 8), baud rate(s)
- MS/TP master (Clause 9), baud rate(s): 9600, 19200, 38400, 76800
- MS/TP slave (Clause 9), baud rate(s):
- Point-To-Point, EIA 232 (Clause 10), baud rate(s):
- Point-To-Point, modem, (Clause 10), baud rate(s):



LonTalk, (Clause 11), medium:

Other:

Device Address Binding:

Is static device binding supported? (This is currently necessary for two-way communication with MS/TP slaves and certain other devices.)  Yes  No

Networking Options:

Router, Clause 6 - List all routing configurations, e.g., ARCNET-Ethernet, Ethernet-MS/TP, etc.

Annex H, BACnet Tunneling Router over IP

BACnet/IP Broadcast Management Device (BBMD)

Does the BBMD support registrations by Foreign Devices?  Yes  No

Character Sets Supported:

Indicating support for multiple character sets does not imply that they can all be supported simultaneously.

ANSI X3.4

IBM/Microsoft

DBCS

ISO 8859-1

ISO 10646 (UCS-2)

ISO 10646 (UCS-4)

JIS C 6226

If this product is a communication gateway, describe the types of non-BACnet equipment/network(s) that the gateway supports:

Not supported

**This Page Intentionally Blank**

# Appendix: D

## **MEMOBUS/Modbus Communications**

---

<b>D.1</b>	<b>MEMOBUS/MODBUS CONFIGURATION.....</b>	<b>396</b>
<b>D.2</b>	<b>COMMUNICATION SPECIFICATIONS.....</b>	<b>397</b>
<b>D.3</b>	<b>CONNECTING TO A NETWORK.....</b>	<b>398</b>
<b>D.4</b>	<b>MEMOBUS/MODBUS SETUP PARAMETERS.....</b>	<b>400</b>
<b>D.5</b>	<b>BYPASS OPERATIONS BY MEMOBUS/MODBUS.....</b>	<b>402</b>
<b>D.6</b>	<b>COMMUNICATIONS TIMING.....</b>	<b>403</b>
<b>D.7</b>	<b>MESSAGE FORMAT.....</b>	<b>404</b>
<b>D.8</b>	<b>MESSAGE EXAMPLES.....</b>	<b>406</b>
<b>D.9</b>	<b>MEMOBUS/MODBUS DATA TABLE.....</b>	<b>408</b>
<b>D.10</b>	<b>ENTER COMMAND.....</b>	<b>421</b>
<b>D.11</b>	<b>COMMUNICATION ERRORS.....</b>	<b>422</b>

### D.1 MEMOBUS/Modbus Configuration

Z1000 Bypasses can be controlled from a PLC or other master device via serial communications using the MEMOBUS/Modbus protocol.

MEMOBUS/Modbus communications can be configured using one master (PLC) and up to 31 slaves. The bypass has slave functionality only, and serial communication is normally initiated from the master and responded to by the slaves.

The master performs serial communications with only one slave at a time. The address or node for each slave must be set beforehand so that the master can communicate with the slave at that address. A slave that receives a command from the master will perform the specified function and then send a response back to the master.

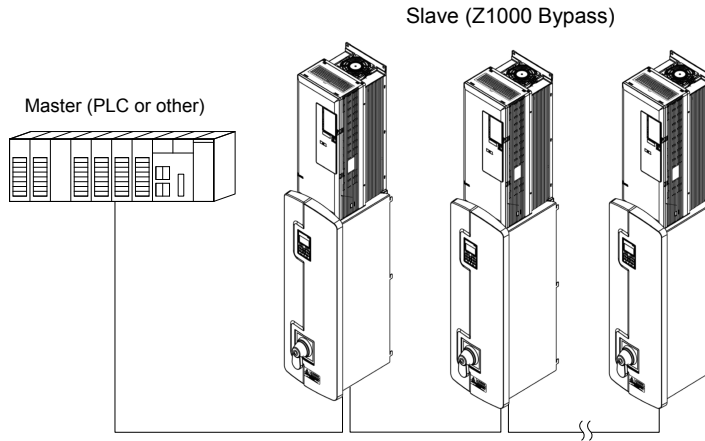

Figure D.1 Connecting Multiple Z1000 Bypasses to a PLC

## D.2 Communication Specifications

MEMOBUS/Modbus specifications appear in the following table:

Item	Specifications	
Interface	RS-485	
Communications Cycle	Asynchronous (Start-stop synchronization)	
Communication Parameters	Communication Speeds Available	1200, 2400, 4800, 9600, 19200, 38400, 57600, 76800, 115200 bps
	Data length	8-bit (fixed)
	Parity	Select even, odd, or none
	Stop bit	1-bit (fixed)
Protocol	MEMOBUS/Modbus (using RTU mode only)	
Max Number of Slaves	31 bypasses	

### D.3 Connecting to a Network

This section explains how to connect the drive to a MEMOBUS/Modbus network and the network termination required for a connection.

#### ◆ Network Cable Connection

Follow the instructions below to connect the bypass to a MEMOBUS/Modbus network.

1. With the power shut off, connect the communications cable to the bypass controller and the master. Use terminal TB3 for MEMOBUS/Modbus.

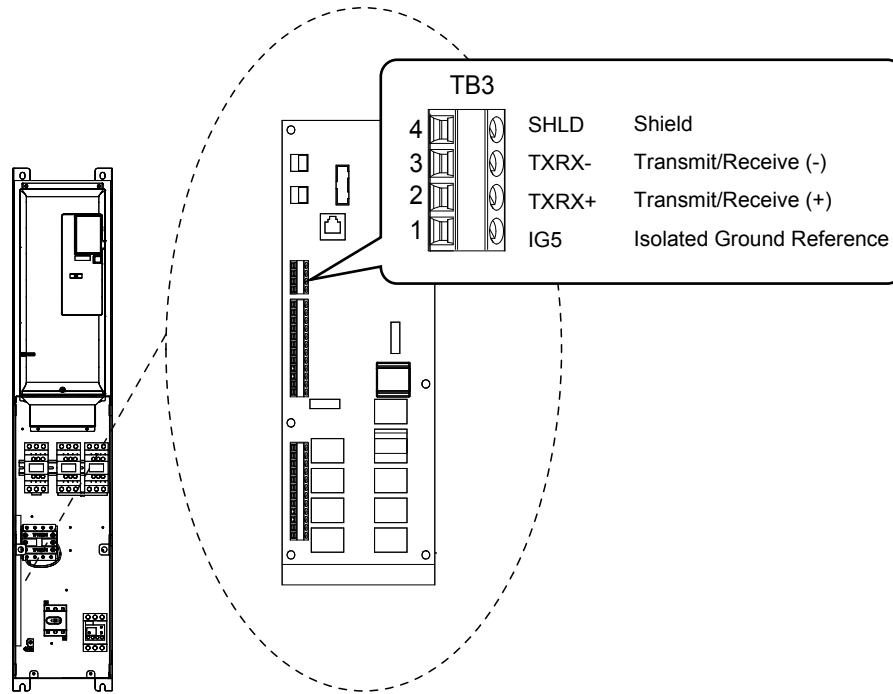

Figure D.2 Serial Communications Cable Connection Terminal (TB3)

**Note:** Separate the communications cables from the main circuit cables and other wiring and power cables. Use shielded cables for the communications cables, and properly shielded clamps to prevent problems caused by electrical interference.

2. Check or set the termination resistor selection at all slaves. Use the description in [Network Termination](#) on page 379 for slaves that are Z1000 Bypasses.
3. Switch the power on.
4. Set the parameters needed for serial communications (Z3-01 through Z3-07) using the digital operator.
5. Shut the power off and wait until the display on the digital operator goes out completely.
6. Turn the power back on.
7. The bypass is now ready to begin communicating with the master.

## ◆ Wiring Diagram for Multiple Connections

Figure C.3 explains the wiring diagrams for multiple connections using MEMOBUS/Modbus communication.

### ■ RS-485 Interface

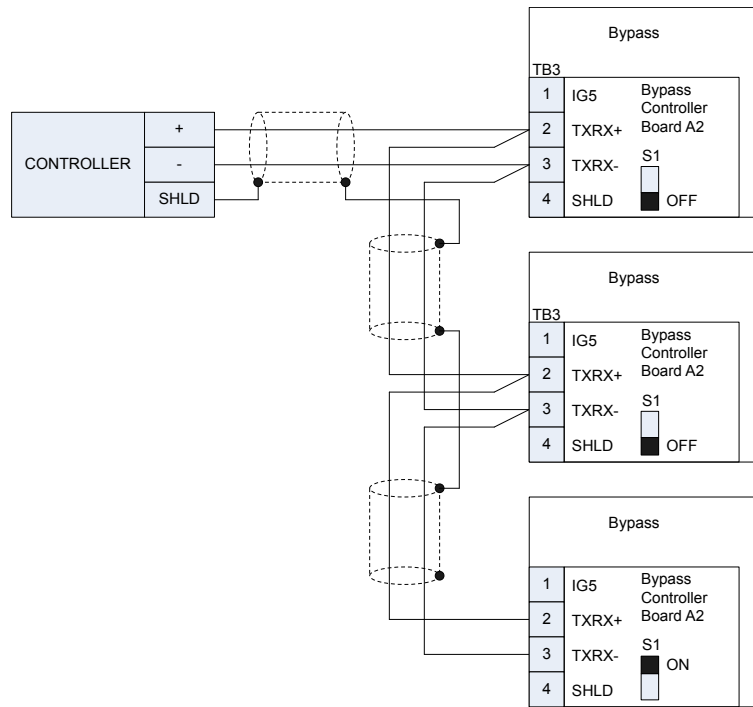

Figure D.3 Connection Diagram for Multiple Connections

**Note:** Turn on DIP switch S1 on the bypass controller located at the end of the network. If S1 is missing, then an external 120 ohm resistor must be placed across terminals TXRX+ and TXRX-. All other slave devices must have this DIP switch set to the OFF position (or if S1 is missing, no external resistor is used).

## ◆ Network Termination

The two ends of the MEMOBUS/Modbus network line have to be terminated with a 120 ohm resistor between the TXRX+ and TXRX- signals. The Z1000 Bypass has a built in termination resistor that can be enabled or disabled using DIP switch S1. If a bypass is located at the end of a network line, enable the termination resistor by setting DIP switch S1 to the ON position. Disable the termination resistor on all slaves that are not located at the network line end.

**Note:** Some bypass controllers do not have DIP switch S1. If this is the case, then an external 120 ohm resistor must be placed across the TXRX+ and TXRX- signals if the bypass controller is at the end of a network line.

## D.4 MEMOBUS/Modbus Setup Parameters

### ◆ MEMOBUS/Modbus Serial Communication

Changes to MEMOBUS/Modbus communications settings become effective after restarting the drive.

#### ■ Z3-01: Serial Communications Protocol Select

Selects the bypass serial communications protocol.

No.	Name	Setting Range	Default
Z3-01	Serial Communications Protocol Select	0 to 3	3

**Setting 0: Modbus**

**Setting 1: N2**

**Setting 2: P1**

**Setting 3: BACnet**

#### ■ Z3-02: Serial Communications Node Select

Selects the bypass serial communications node address.

**Note:** Each slave must be assigned a unique slave address for serial communications to work properly. Slave addresses do not need to be assigned in sequential order, but no two slaves may share the same address.

No.	Name	Setting Range	Default
Z3-02	Serial Communications Node Select	0 to 127	1

#### ■ Z3-03: Serial Communications Baud Rate Select

Selects the bypass serial communications speed.

Selecting settings 0, 1, or 2 will trigger an oPE29 error when using BACnet communication (Z3-01 = 3) in bypass controller software versions VST800400 and later.

No.	Name	Setting Range	Default
Z3-03	Serial Communications Baud Rate Select	0 to 8	3

**Setting 0: 1200 bps**

**Setting 1: 2400 bps**

**Setting 2: 4800 bps**

**Setting 3: 9600 bps**

**Setting 4: 19200 bps**

**Setting 5: 38400 bps**

**Setting 6: 57600 bps**

**Setting 7: 76800 bps**

**Setting 8: 115200 bps**

#### ■ Z3-04: Serial Communications Parity Select

Selects the bypass serial communications parity. This setting is ignored when BACnet protocol is selected.

No.	Name	Setting Range	Default
Z3-04	Serial Communications Parity Select	0 to 2	0

**Setting 0: No Parity**

**Setting 1: Even Parity**

**Setting 2: Odd Parity**



### ■ Z3-05: Serial Communications Fault Select

Selects the action to take when a serial communications fault is detected. A serial communications fault is detected when after last communicating, no communications occurs within the time set to Z3-06.

No.	Name	Setting Range	Default
Z3-05	Serial Communications Fault Select	0 to 4	1

**Setting 0: Ignore**

**Setting 1: Alarm Only**

**Setting 2: Fault with EF0**

An EF0 fault will be sent to the drive.

**Setting 3: Fault with EF0 and Open Contactors**

An EF0 fault will be sent to the drive and the bypass contactor (K3) will be opened.

**Setting 4: Alarm and run at preset speed set in Z3-10**

Display AL14 alarm on operator.

### ■ Z3-06: Serial Communications Fault Time Select

Sets the time allowed to elapse since receiving serial communications before triggering a communications fault.

A value of 0.0 means to never time out.

No.	Name	Setting Range	Default
Z3-06	Serial Communications Fault Time Select	0.0 s to 99.9 s	2.0 s

### ■ Z3-07: Serial Communications Receive to Transmit Wait Time

Sets the time to delay a serial communications response to a serial communications command.

No.	Name	Setting Range	Default
Z3-07	Serial Communications Receive to Transmit Wait Time	0 to 99 ms	5 ms

### D.5 Bypass Operations by MEMOBUS/Modbus

The bypass operations that can be performed by MEMOBUS/Modbus communication depend on parameter settings. This section explains the functions that can be used and related parameter settings.

---

#### ◆ Observing the Bypass Operation

A controller can perform the following actions with MEMOBUS/Modbus communications at any time regardless of parameter settings:

- Observe bypass and drive status and control terminal status from a controller
- Read and write parameters
- Set and reset faults
- Set multi-function inputs.

**Note:** Input settings from the input terminals DI-□□ and S□ and from MEMOBUS/Modbus communications are both linked by a logical OR operation.

## D.6 Communications Timing

To prevent a communications overrun in the slave drive, the master should wait a certain time between sending messages to the same drive. In the same way, the slave drive must wait before sending response messages to prevent an overrun in the master. This section explains the message timing.

### ◆ Command Messages from Master to Bypass

The master must wait for a specified time between receiving a response and resending the same type of command to the same bypass drive to prevent overrun and data loss. The minimum wait time depends on the command as shown in [Table D.1](#).

**Table D.1 Minimum Wait Time for Sending Messages**

Command Type	Example	Minimum Wait Time
1	<ul style="list-style-type: none"> <li>Control command (Run, Stop)</li> <li>Set inputs/outputs</li> <li>Read monitors and parameter values</li> </ul>	5 ms </>
2	Write parameters	200 ms </>
3	Save changes using an Enter command	200 ms to 2 s, depending on the number of parameters that were changed </>
4	Enter with storage to drive EEPROM after initialization	5 s

<1> If the drive receives command type 1 data during the minimum wait time, it will perform the command and then respond. However, if it receives a command type 2 or 3 during that time, either a communication error will result or the command will be ignored.

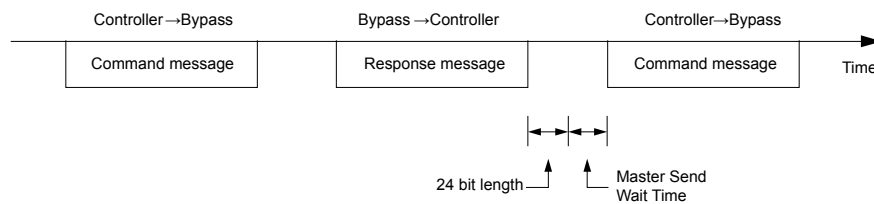
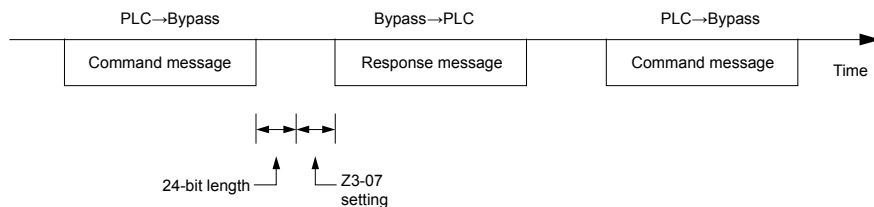

**Figure D.4 Minimum Wait Time for Sending Messages**

Set a timer in the master to check how long it takes for the slave bypass(es) to respond to the master. If no response is received within a certain amount of time, the master should try resending the message.

### ◆ Response Messages from Bypass to Master

If the bypass receives a command from the master, it will process the data received and wait for the time set in Z3-07 until it responds. Increase Z3-07 if the bypass response causes overrun in the master.



**Figure D.5 Minimum Response Wait Time**

## D.7 Message Format

### ◆ Message Content

In MEMOBUS/Modbus communications, the master sends commands to the slave, and the slave responds. The message format is configured for both sending and receiving as shown below, and the length of data packets depends on the command (function) content.

SLAVE ADDRESS
FUNCTION CODE
DATA
ERROR CHECK

### ◆ Slave Address

The slave address in the message defines the note the message is sent to. Use addresses between 0 and FF (hex). If a message with slave address 0 is sent (broadcast), the command from the master will be received by all slaves. The slaves do not provide a response to a broadcast type message.

### ◆ Function Code

The three types of function codes are shown in the table below.

Function Code	Function Name	Data Length (bytes)			
		Command Message		Response Message	
		Minimum	Maximum	Minimum	Maximum
03H	Read MEMOBUS/Modbus registers	8	8	7	37
08H	Loopback test	8	8	8	8
10H	Write to multiple MEMOBUS/Modbus registers	11	41	8	8

### ◆ Data

Configure consecutive data by combining the MEMOBUS/Modbus register address (test code in case of a loopback test) and the data the register contains. The data length changes depending on the command details.

A bypass MEMOBUS/Modbus register always has a data length of two bytes. Data written into drive registers must also always have a length of two bytes. Register data read out from the drive will always consist of two bytes.

### ◆ Error Check

The bypass uses a CRC-16 (cyclic redundancy check, checksum method) for checking data validity. Use the procedure described below when calculating the CRC-16 checksum for command data or when verifying response data.

#### ■ Command Data

When the drive receives data, it calculates the CRC-16 checksum from the data and compares it to the CRC-16 value received within the message. Both must match before a command is processed.

An initial value of FFFFH (i.e., all 16 bits equal 1) must be used for CRC-16 calculations in the MEMOBUS/Modbus protocol.

Calculate the CRC-16 checksum using the following steps:

1. The starting value is FFFFH.
2. Perform an XOR operation of this value and the slave address.
3. Right shift the result.
4. When the overflow bit of the shift operation becomes 1, perform an XOR operation of the result from step 3 above and the fix value A001H.
5. Repeat steps 3 and 4 until eight shift operations have been performed.
6. After eight shift operations, perform an XOR operation with the result and the next data in the message (function code, register address, data). Continue with steps 3 to 5 until the last data has been processed.
7. The result of the last shift or XOR operation is the checksum.

The example in *Table D.2* shows the CRC-16 calculation of the slave address 02H and the function code 03H, yielding the result D140H.

**Note:** This example does not show the calculation for a complete MEMOBUS/Modbus command. Normally data would follow in the calculation.

**Table D.2 CRC-16 Checksum Calculation Example**

Description	Calculation	Overflow	Description	Calculation	Overflow
Initial Value (FFFFH)	1111 1111 1111 1111		Function Code 03H	0000 0000 0000 0011	
Address 02H	0000 0000 0000 0010		XOR w result	1000 0001 0011 1101	
XOR w initial value	1111 1111 1111 1101		Shift 1	0100 0000 1001 1110	1
Shift 1	0111 1111 1111 1110	1	XOR w A001H	1010 0000 0000 0001	
XOR w A001H	1010 0000 0000 0001		XOR result	1110 0000 1001 1111	
XOR result	1101 1111 1111 1111		Shift 2	0111 0000 0100 1111	1
Shift 2	0110 1111 1111 1111	1	XOR w A001H	1010 0000 0000 0001	
XOR w A001H	1010 0000 0000 0001		XOR result	1101 0000 0100 1110	
XOR result	1100 1111 1111 1110		Shift 3	0110 1000 0010 0111	0
Shift 3	0110 0111 1111 1111	0	Shift 4	0011 0100 0001 0011	1
Shift 4	0011 0011 1111 1111	1	XOR w A001H	1010 0000 0000 0001	
XOR w A001H	1010 0000 0000 0001		XOR result	1001 0100 0001 0010	
XOR result	1001 0011 1111 1110		Shift 5	0100 1010 0000 1001	0
Shift 5	0100 1001 1111 1111	0	Shift 6	0010 0101 0000 0100	1
Shift 6	0010 0100 1111 1111	1	XOR w A001H	1010 0000 0000 0001	
XOR w A001H	1010 0000 0000 0001		XOR result	1000 0101 0000 0101	
XOR result	1000 0100 1111 1110		Shift 7	0100 0010 1000 0010	1
Shift 7	0100 0010 0111 1111	0	XOR w A001H	1010 0000 0000 0001	
Shift 8	0010 0001 0011 1111	1	XOR result	1110 0010 1000 0011	
XOR w A001H	1010 0000 0000 0001		Shift 8	0111 0001 0100 0001	1
XOR result	1000 0001 0011 1110		XOR w A001H	1010 0000 0000 0001	
Perform operations with next data (function code)			XOR result	1101 0001 0100 0000	
			CRC-16	1101 0001 0100 0000	
				D 1 4 0 (Lower) (Upper)	
			Continue from here with next data.		

**Response Data**

Perform a CRC-16 calculation on the response message data as described above as a validation check. The result should match the CRC-16 checksum received within the response message.

## D.8 Message Examples

Below are some examples of command and response messages.

### ◆ Reading Drive MEMOBUS/Modbus Register Contents

Using the function code 03H (Read), a maximum of 16 MEMOBUS/Modbus registers can be read out at a time.

The following table shows message examples when reading status signals, error details, data link status, and frequency references from the slave 2 drive.

Command Message			Response Message (normal)			Response Message (fault)		
Slave Address		02H	Slave Address		02H	Slave Address		02H
Function Code		03H	Function Code		03H	Function Code		83H
Starting No.	Upper	00H	Data Quantity		08H	Error Code		03H
	Lower	20H	1st storage register	Upper	00H	CRC-16	Upper	F1H
Data Quantity	Upper	00H		Lower	65H		Lower	31H
	CRC-16	Upper	45H	Next storage register	Upper	00H		
Lower		04H	Lower		00H			
CRC-16	Upper	45H	Next storage register	Upper	00H			
	Lower	F0H		Lower	00H			
CRC-16	Upper	45H	Next storage register	Upper	01H			
	Lower	F0H		Lower	F4H			
CRC-16	Upper	45H	CRC-16	Upper	AFH			
	Lower	F0H		Lower	82H			

### ◆ Loopback Test

Function code 08H performs a loopback test that returns a response message with exactly the same content as the command message. The response message can be used to check communications between the master and slave. User-defined test code and data values can also be set.

The following table shows a message example when performing a loopback test with the slave 1 drive.

Command Message			Response Message		
Slave Address		01H	Slave Address		01H
Function Code		08H	Function Code		08H
Test Code	Upper	00H	Test Code	Upper	00H
	Lower	00H		Lower	00H
Data	Upper	A5H	Data	Upper	A5H
	Lower	37H		Lower	37H
CRC-16	Upper	DAH	CRC-16	Upper	DAH
	Lower	8DH		Lower	8DH

## ◆ Writing to Multiple Registers

Function code 10H allows the user to write multiple MEMOBUS/Modbus registers with one message. This process works similar to reading registers, in that the address of the first register to be written and the data quantity are set in the command message. The data to be written must be consecutive so that the register addresses are in order, starting from the specified address in the command message. The data order must be high byte then lower byte.

The following table shows an example of a message where a forward operation has been set with a frequency reference of 60.0 Hz for the slave 1 drive.

If parameter values are changed using the Write command, an Enter command is necessary to save the data. *Refer to Enter Command on page 390* for detailed descriptions.

Command Message			Response Message (normal)			Response Message (fault)					
Slave Address		01H	Slave Address		01H	Slave Address		01H			
Function Code		10H	Function Code		10H	Function Code		90H			
Starting No.	Upper	00H	Starting No.	Upper	00H	Error Code		02H			
	Lower	01H		Lower	01H	CRC-16	Upper	CDH			
Data Quantity	Upper	00H	Data Quantity	Upper	00H		Lower	C1H			
	Lower	02H		Lower	02H						
Number of Bytes		04H	CRC-16	Upper	10H						
Starting Data	Upper	00H		Lower	08H						
	Next Data	Upper	02H								
Lower		58H									
CRC-16	Upper	63H									
	Lower	39H									

**Note:** Double the number of the data quantity for the number of bytes in the command message.

## D.9 MEMOBUS/Modbus Data Table

The tables below list all MEMOBUS/Modbus data.

The MEMOBUS register hex addresses for parameters are listed beginning on page [329](#).

### ◆ Command Data

It is possible to both read and write command data.

**Note:** Bits that are not used should be set to 0. Refrain from writing to reserved registers.

Register No.	Contents	
0000H	Reserved	
0001H	Operation Commands and Multi-function Inputs	
	bit 0	Reserved
	bit 1	Reserved
	bit 2	External Fault (EF0)
	bit 3	Fault Reset
	bit 4	Reserved
	bit 5	Reserved
	bit 6	Multi-Function Input 3
	bit 7	Multi-Function Input 4
	bit 8	Multi-Function Input 5
	bit 9	Multi-Function Input 6
	bit A	Multi-Function Input 7
	bit B to F	Reserved
0002H	Reserved	Reserved
0003H	V/f Gain	
0004H, 0005H	Reserved	
0006H	PI Target, 0.01% units, signed	
0007H	Analog Output Terminal FM Setting (10 V / 4000 H)	
0008H	Analog Output Terminal AM Setting (10 V / 4000 H)	
0009H	Settings for Multi-Function Digital Outputs	
	bit 0	Multi-Function Contact Output 1 (terminal M1-M2)
	bit 1	Multi-Function Contact Output 2 (terminal M3-M4)
	bit 2	Multi-Function Contact Output 3 (terminal M5-M6)
	bit 3 to 5	Reserved
	bit 6	Enables the function in bit 7
	bit 7	Fault Contact Output (terminal MA/MB-MC)
bit 8 to F	Reserved	
000AH to 000CH	Reserved	
000DH	PI2 Setpoint	
000EH	Reserved	
000FH	Control Selection Setting	
	bit 0	Reserved
	bit 1	PI Setpoint Input
	bit 2, bit 3	Reserved
	bit 4	PI2 Target Input (enables the setting from MEMOBUS/Modbus)
	bit 5 to B	Reserved
	bit C	Enable Terminal S5 Input for Broadcast Data
	bit D	Enable Terminal S6 Input for Broadcast Data
	bit E	Enable Terminal S7 Input for Broadcast Data
bit F	Reserved	



Register No.	Contents
0010H to 001FH	Reserved

## ◆ Monitor Data

Monitor data can be read only.

Register No.	Contents	
0020H	Drive Status 1	
	bit 0	During Run
	bit 1	During Reverse
	bit 2	Drive Ready
	bit 3	Fault
	bit 4	Data Setting Error
	bit 5	Multi-Function Contact Output 1 (terminal M1-M2)
	bit 6	Multi-Function Contact Output 2 (terminal M3-M4)
	bit 7	Multi-Function Contact Output 3 (terminal M5-M6)
	bit 8 to D	Reserved
	bit E	ComRef status
bit F	ComCtrl status	
0021H	Fault Contents 1	
	bit 0	Overcurrent (oC), Ground fault (GF)
	bit 1	Overvoltage (ov)
	bit 2	Drive Overload (oL2)
	bit 3	Overheat 1 (oH1), Drive Overheat Warning (oH2)
	bit 4, bit 5	Reserved
	bit 6	PI Feedback Loss (FbL / FbH)
	bit 7	EF to EF7: External Fault
	bit 8	CPF□□: Hardware Fault (includes oFx)
	bit 9	Motor Overload (oL1), Overtorque Detection 1 (oL3), Undertorque Detection 1 (UL3)
	bit A	Reserved
	bit B	Main Circuit Undervoltage (Uv)
	bit C	Undervoltage (Uv1), Control Power Supply Undervoltage (Uv2), Soft Charge Circuit Fault (Uv3)
	bit D	Output Phase Loss (LF), Input Phase Loss (PF)
bit E	MEMOBUS/Modbus Communication Error (CE), Option Communication Error (bUS)	
bit F	Operator Connection Fault (oPr)	
0022H	Data Link Status	
	bit 0	Writing data or switching motors
	bit 1	Reserved
	bit 2	Reserved
	bit 3	Upper or lower limit error
	bit 4	Data conformity error
	bit 5	Writing to EEPROM
bit 6 to F	Reserved	
0023H	Frequency Reference $\langle \! / \! \rangle$	
0024H	Output Frequency $\langle \! / \! \rangle$	
0025H	Output Voltage Reference, 0.1 V units (units are determined by parameter H5-10)	
0026H	Output Current, 0.1 A units	
0027H	Output Power	
0028H	Reserved	

## D.9 MEMOBUS/Modbus Data Table

Register No.	Contents	
0029H	Fault Contents 2	
	bit 0	Reserved
	bit 1	Ground Fault (GF)
	bit 2	Input Phase Loss (PF)
	bit 3	Output Phase Loss (LF)
	bit 4, bit 5	Reserved
	bit 6	Motor Overheat 2 (PTC input) (oH4)
	bit 7 to F	Reserved
002AH	Alarm Contents 1	
	bit 0, 1	Reserved
	bit 2	Run Command Input Error (EF)
	bit 3	Drive Baseblock (bb)
	bit 4	Overtorque Detection 1 (oL3)
	bit 5	Heatsink Overheat (oH)
	bit 6	Overvoltage (ov)
	bit 7	Undervoltage (Uv)
	bit 8	Cooling Fan Error (FAn)
	bit 9	MEMOBUS/Modbus Communication Error (CE)
	bit A	Option Communication Error (bUS)
	bit B	Undertorque Detection 1 (UL3)
	bit C	Motor Overheat (oH3)
	bit D	PI Feedback Loss (FbL, FbH)
	bit E	Reserved
bit F	Serial Communication Transmission Error (CALL)	
002BH	Input Terminal Status	
	bit 0	Terminal S1 Closed
	bit 1	Terminal S2 Closed
	bit 2	Terminal S3 Closed
	bit 3	Terminal S4 Closed
	bit 4	Terminal S5 Closed
	bit 5	Terminal S6 Closed
	bit 6	Terminal S7 Closed
bit 7 to F	Reserved	
002CH	Drive Status 2	
	bit 0	During Run
	bit 1	Zero Speed
	bit 2	Speed Agree
	bit 3	User Speed Agree
	bit 4	Frequency Detection 1
	bit 5	Frequency Detection 2
	bit 6	Drive Ready
	bit 7	During Undervoltage
	bit 8	During Baseblock
	bit 9	Frequency Reference from Operator Keypad
	bit A	Run Command from Operator Keypad
	bit B	Over/Undertorque 1
	bit C	Frequency Reference Loss
	bit D	During Fault Restart
bit E	Fault	
bit F	Communication Timeout	

Register No.	Contents	
002DH	Output Terminal Status	
	bit 0	Multi-Function Contact Output 1 (terminal M1-M2)
	bit 1	Multi-Function Contact Output 2 (terminal M3-M4)
	bit 2	Multi-Function Contact Output 3 (terminal M5-M6)
	bit 3 to 6	Reserved
	bit 7	Fault Contact Output (terminal MA/MB-MC)
bit 8 to F	Reserved	
002EH	Reserved	
002FH	Frequency Reference Bias (from Up/Down 2 Function), 0.1% units	
0030H	Reserved	
0031H	DC Bus Voltage, 1 Vdc units	
0032H, 0033H	Reserved	
0034H	Product Code 1 [ASCII], Product Type (Z0 for Z1000)	
0035H	Product Code 2 [ASCII], Region Code	
0036H, 0037H	Reserved	
0038H	PI Feedback, 0.1% units, unsigned, 100% / max. output frequency	
0039H	PI Input, 0.1% units, signed, 100% / max. output frequency	
003AH	PI Output, 0.1% units, signed, 100% / max. output frequency	
003BH, 003CH	Reserved	
003DH	Communications Error Contents <>	
	bit 0	CRC Error
	bit 1	Data Length Error
	bit 2	Reserved
	bit 3	Parity Error
	bit 4	Overflow Error
	bit 5	Framing Error
	bit 6	Timeout
bit 7 to F	Reserved	
003EH	Output Frequency	r/min <4>
003FH		0.01% units
0040H to 004AH	Used for various monitors U1-□□. <i>Refer to U: Monitors on page 354</i> for parameter details.	
004BH	Drive status (U1-12)	
	bit 0	During Run
	bit 1	During Zero Speed
	bit 2	During Reverse Run
	bit 3	During Fault Reset Signal Input
	bit 4	During Speed Agree
	bit 5	Drive Ready
	bit 6	Alarm
	bit 7	Fault
	bit 8	During Operation Error (oPE□□)
	bit 9	During Momentary Power Loss
	bit A, bit B	Reserved
bit E	ComRef status, NetRef status	
bit F	ComCtrl status, NetCtrl status	
004CH to 007EH	Used for various monitors U1-□□, U4-□□, U5-□□ and U6-□□. <i>Refer to U: Monitors on page 354</i> for parameter details.	
007FH	Alarm Code, <i>Refer to Alarm Register Contents on page 420</i> for alarm codes.	
0080H to 0097H	Used for monitors U2-□□, U3-□□. <i>Refer to U: Monitors on page 354</i> for parameter details and <i>Refer to Fault Trace Contents on page 418</i> for register value descriptions.	
0098H	High Word of Accumulated Operation Time Monitor, 10 h units (U4-01)	

## D.9 MEMOBUS/Modbus Data Table

Register No.	Contents		
0099H	Low Word of Accumulated Operation Time Monitor, 1 h units (U4-01)		
009AH	High Word of Cooling Fan Operation Time Monitor (U4-03)		
009BH	Low Word of Cooling Fan Operation Time Monitor (U4-03)		
009CH to 00AAH	Reserved		
00ABH	Drive Rated Current <3>		
00ACH	Motor Speed (U1-05)	r/min units <4>	
00ADH	<b>Note:</b> Not available in Z1000.	0.01% units	
00AEH to 00B4H	Reserved		
00B5H	Frequency Reference After	r/min units <4>	
00B6H	Soft-starter (U1-16)	0.01% units	
00B7H	Frequency Reference	r/min <4>	
00B8H		0.01% units	
00B9H to 00BEH	Reserved		
00BFH	Lists the last two digits of operation error code oPE□□.		
00C0H	Fault Contents 3		
	bit 1	Undervoltage (Uv1)	
	bit 2	Control Power Supply Undervoltage (Uv2)	
	bit 3	Soft Charge Circuit Fault (Uv3)	
	bit 4	Reserved	
	bit 5	Ground Fault (GF)	
	bit 6	Overcurrent (oC)	
	bit 7	Overvoltage (ov)	
	bit 8	Heatsink Overheat (oH)	
	bit 9	Heatsink Overheat (oH1)	
	bit A	Motor Overload (oL1)	
	bit B	Drive Overload (oL2)	
	bit C	Overtorque Detection 1 (oL3)	
bit D to F	Reserved		
00C1H	Fault Contents 4		
	bit 0	External Fault at input terminal S3 (EF3)	
	bit 1	External Fault at input terminal S4 (EF4)	
	bit 2	External Fault at input terminal S5 (EF5)	
	bit 3	External Fault at input terminal S6 (EF6)	
	bit 4	External Fault at input terminal S7 (EF7)	
	bit 5	Reserved	
	bit 6	Cooling Fan Error (FAn)	
	bit 7 to 9	Reserved	
	bit A	Input Phase Loss (PF)	
	bit B	Output Phase Loss (LF)	
	bit C	Motor Overheat (PTC input) (oH3)	
	bit D	Digital Operator Connection Fault (oPr)	
	bit E	EEPROM Write Error (Err)	
bit F	Motor Overheat Fault (PTC input) (oH4)		

Register No.	Contents	
00C2H	Fault Contents 5	
	bit 0	MEMOBUS/Modbus Communication Error (CE)
	bit 1	Option Communication Error (bUS)
	bit 2 to 5	Reserved
	bit 6	Option External Fault (EF0)
	bit 7	PI Feedback Loss (FbL)
	bit 8	Undertorque Detection 1 (UL3)
	bit 9	Reserved
	bit A	High Slip Braking Overload (oL7)
	bit B to E	Reserved
	bit F	Hardware Fault (includes oFx)
00C3H	Fault Contents 6	
	bit 0 to 4	Reserved
	bit 5	Current Imbalance (LF2)
	bit 6	Pullout Detection (STo)
	bit 7 to 9	Reserved
	bit A	Too Many Speed Search Restarts (SEr)
bit B to F	Reserved	
00C4H	Fault Contents 7	
	bit 0	PI Feedback Loss (FbH)
	bit 1	External Fault 1, input terminal S1 (EF1)
	bit 2	External Fault 2, input terminal S2 (EF2)
	bit 3, bit 4	Reserved
	bit 5	Current Offset Fault (CoF)
	bit 6 to B	Reserved
	bit C	Output Voltage Detection Fault (voF)
bit D to F	Reserved	
00C5H	Fault Contents 8	
	bit 0	Reserved
	bit 1	Node Setup Fault (nSE)
	bit 2 to 5	Reserved
	bit 9	Motor Underload Protection (UL6)
bit A to F	Reserved	
00C6H, 00C7H	Reserved	

## D.9 MEMOBUS/Modbus Data Table

Register No.	Contents	
00C8H	Alarm Contents 2	
	bit 0	Undervoltage (Uv)
	bit 1	Overvoltage (ov)
	bit 2	Heatsink Overheat (oH)
	bit 3	Drive Overheat (oH2)
	bit 4	Overtorque 1 (oL3)
	bit 5	Reserved
	bit 6	Run Commands Input Error (EF)
	bit 7	Drive Baseblock (bb)
	bit 8	External Fault 3, input terminal S3 (EF3)
	bit 9	External Fault 4, input terminal S4 (EF4)
	bit A	External Fault 5, input terminal S5 (EF5)
	bit B	External Fault 6, input terminal S6 (EF6)
	bit C	External Fault 7, input terminal S7 (EF7)
	bit D	Reserved
	bit E	Cooling Fan Error (FAn)
bit F	Reserved	
00C9H	Alarm Contents 3	
	bit 0, bit 1	Reserved
	bit 2	Digital Operator Connection Fault (oPr)
	bit 3	MEMOBUS/Modbus Communication Error (CE)
	bit 4	Option Communication Error (bUS)
	bit 5	Reserved
	bit 6	Motor Overload (oL1)
	bit 7	Drive Overload (oL2)
	bit 8	Reserved
	bit 9	Option Card External fault (EF0)
	bit A, bit B	Reserved
	bit C	Serial Communication Transmission Error (CALL)
	bit D	Undertorque Detection 1 (UL3)
	bit E	Reserved
bit F	MEMOBUS/Modbus Test Mode Fault (SE)	
00CAH	Alarm Contents 4	
	bit 0	Reserved
	bit 1	Motor Overheat 1 (PTC Input) (oH3)
	bit 2 to 5	Reserved
	bit 6	PI Feedback Loss (FbL)
	bit 7	PI Feedback Loss (FbH)
	bit 9	Drive Disabled (dnE)
bit A to F	Reserved	
00CBH	Alarm Contents 5	
	bit 0 to 2	Reserved
	bit 3	High Current Alarm (HCA)
	bit 4	Cooling Fan Maintenance Time (LT-1)
	bit 5	Soft Charge Bypass Relay Maintenance Time (LT-2)
	bit 6, 7	Reserved
	bit 8	External Fault 1 (input terminal S1) (EF1)
	bit 9	External Fault 2 (input terminal S2) (EF2)
bit A to F	Reserved	

Register No.	Contents	
00CCH	Alarm Contents 6	
	bit 0	Output Voltage Detection Fault (VoF)
	bit 1	Reserved
	bit 2	Capacitor Maintenance Time (LT-3)
	bit 3 to C	Reserved
	bit D	Motor Underload Protection (UL6)
	bit E	Waiting for Run (WrUn)
	bit F	Reserved
00CDH	Reserved	
00CEH	Alarm Contents 7	
	bit 2	Time Not Set (TIM)
	bit 3	Operator Battery Low (bAT)
	bit 4	Time Data Error (TdE)
	bit 5	External Fan Fault (Fn1)
	bit 6	Emergency Override Forward Run (EoF)
	bit 7	Emergency Override Reverse Run (Eor)
00CFH	Reserved	
00D0H	CPF Contents 1	
	bit 0, 1	Reserved
	bit 2	A/D Conversion Error (CPF02)
	bit 3	PWM Data Fault (CPF03)
	bit 4, 5	Reserved
	bit 6	EEPROM Memory Data Error (CPF06)
	bit 7	Terminal Board Connection Error (CPF07)
	bit 8	EEPROM Serial Communications Fault (CPF08)
00D1H	CPF Contents 2	
	bit 0 to 3	Reserved
	bit 4	Hardware fault at power up (CPF20)
	bit 5	Hardware fault at communication start up (CPF21)
	bit 6	A/D Conversion Fault (CPF22)
	bit 7	PWM Feedback Fault (CPF23)
	bit 8	Drive Unit Signal Fault (CPF24)
00D2H	Reserved	
00D3H to 00D7H	oFA0x Contents (CN5)	
00D8H	oFA0x Contents (CN5)	
	bit 0	Option Compatibility Error (oFA00)
	bit 1	Option not properly connected (oFA01)
	bit 2 to 4	Reserved
	bit 5	A/D Conversion Error (oFA05)
	bit 6	Option Response Error (oFA06)
	bit 7 to F	Reserved

## D.9 MEMOBUS/Modbus Data Table

Register No.	Contents	
00D9H	oFA1x Contents (CN5)	
	bit 0	Option RAM Fault (oFA10)
	bit 1	Option Operation Mode Fault (SLMoD) (oFA11)
	bit 2	Drive Receive CRC Error (oFA12)
	bit 3	Drive Receive Frame Error (oFA13)
	bit 4	Drive Receive Abort Error (oFA14)
	bit 5	Option Receive CRC Error (oFA15)
	bit 6	Option Receive Frame Error (oFA16)
	bit 7	Option Receive Abort Error (oFA17)
bit 8 to F	Reserved	
00DAH	Reserved	
00DBH	oFA3x Contents (CN5)	
	bit 0	Comm. ID Error (oFA30)
	bit 1	Model Code Error (oFA31)
	bit 2	Sumcheck Error (oFA32)
	bit 3	Comm. option timeout waiting for response (oFA33)
	bit 4	MEMOBUS Timeout (oFA34)
	bit 5	Drive timeout waiting for response (oFA35)
	bit 6	CI Check Error (oFA36)
	bit 7	Drive timeout waiting for response (oFA37)
	bit 8	Control Command Selection Error (oFA38)
	bit 9	Drive timeout waiting for response (oFA39)
	bit A	Control Response Selection 1 Error (oFA40)
	bit B	Drive timeout waiting for response (oFA41)
	bit C	Control Response Selection 2 Error (oFA42)
	bit D	Control Response Selection Error (oFA43)
bit E, bit F	Reserved	
00DCH to 00E9H	Reserved	
00EAH	Fault Contents 9	
	bit 0	Time Not Set (TIM)
	bit 1	Oper Battery Low (bAT)
	bit 2	Time Data Err (TdE)
	bit 3	Time Interval Error (TIE)
	bit 4	Overvoltage 2 (ov2)
	bit 5	Reserved
	bit 6	External Fan Fault (Fn1)
bit 7 to F	Reserved	
00EBH to 00FFH	Reserved	
0100H to 2FFFH	Reserved	
3000H to 3003H	Used for Various Monitors U5-□□. <i>Refer to U: Monitors on page 354</i> for details.	
3004H to 3007H	Reserved	
3008H to 3028H	Used for Various Monitors U2-□□, U3-□□, U5-□□. <i>Refer to U: Monitors on page 354</i> for details.	
3029H to 302EH	Reserved	
302FH to 83FFH	Reserved	



Register No.	Contents	
8400H	BYP Command	Bypass Command. Logically OR'd with the physical inputs XXXXXXXXXXXXXXXXXXXX 
8401H	BYP Freq Ref	Bypass Frequency Reference. This value is sent to the drive if selected by Bypass parameter Z1-07. The units are determined by drive parameter o1-03.
8402H <S>	BYP DI-□□ Command	Bypass Digital Input Command. These bits are logically OR'd with the physical inputs XXXXXXXXXXXXXXXXXXXX 
8403H	BYP DO-□□ Command	Bypass Digital Output Command. These bits allow the digital outputs to be set over a network if the corresponding digital output function is unused. XXXXXXXXXXXXXXXXXXXX 
8404H	Time Set HHMM	Time Set Hours and Minutes. Format is HHMM where HH is hours from 00 to 23 and MM is minutes from 00 to 59. When new HHMM is set to RTC, the seconds will be set to a value of 0.
8405H	Date Set Year	Date Set Year. Format is YYYY where YYYY is the four digit year from 2000 to 2099.
8406H	Date Set MMDD	Date Set Month and Day. Format is MMDD where MM is month from 01 to 12 and DD is day from 01 to 31.
8407H	Set RTC	The date and time values in registers 8404H to 8406H are written to the real time clock (RTC) in the HOA operator connected to the bypass. 0: Do not write values to RTC 1: Write values to RTC
8408H to 843FH	Reserved	

## D.9 MEMOBUS/Modbus Data Table

Register No.	Contents	
8440H	Time HHMM	Time Hours and Minutes. Reads current time. Format is HHMM where HH is hours from 00 to 23 and MM is minutes from 00 to 59. Reads 0x0000 when no RTC option
8441H	Date Year	Date Year. Reads current date. Format is YYYY where YYYY is the year from 0000 to 9999. Reads 0x0000 when there is no RTC option.
8442H	Date Mo Day MMDD	Date Month and Day. Reads current date. Format is MMDD where MM is month from 01 to 12 and DD is day from 01 to 31. Reads 0x0000 when there is no RTC option
8443H to 84FFH	Reserved	
8490H	Product Type Code	
8491H	Product Type Code	
8500H to 87FFH	BYP Parameters and Monitors	Z1-□□, Z2-□□, Z3-□□, Z4-□□, UB-□□. <i>Refer to Parameter List on page 327</i> for Modbus addresses.
8800H to FFFFH	Reserved	

- <1> Parameter o1-03, Digital Operator Display Selection, determines the units.
- <2> Communication error contents are saved until the fault is reset.
- <3> The number of decimal places in the parameter value depends on the drive model. *Refer to Defaults by Drive Model on page 372* for details.
- <4> Set the number of motor poles to parameter E2-04 or E5-05 depending on the motor being used.
- <5> Disabled when Z3-12 is set to 0 in bypass controller software versions VST800298 and later.

### ◆ Broadcast Messages

Data can be written from the master to all slave devices at the same time.

The slave address in a broadcast command message must be set to 00H. All slaves will receive the message, but will not respond.

Register No.	Contents	
0001H	Digital Input Command	
	bit 0	Forward Run (0: Stop 1: Run)
	bit 1	Direction Command (0: Forward, 1: Reverse)
	bit 2, bit 3	Reserved
	bit 4	External Fault
	bit 5	Fault Reset
	bit 6 to B	Reserved
	bit C	Multi-Function Digital Input S5
	bit D	Multi-Function Digital Input S6
	bit E	Multi-Function Digital Input S7
bit F	Reserved	
0002H	Frequency Reference	30000/100%

### ◆ Fault Trace Contents

The table below shows the drive fault codes that can be read out by MEMOBUS/Modbus commands from the U2-□□ monitor parameters.

Table D.3 Fault Trace / History Register Contents

Fault Code	Fault Name	Fault Code	Fault Name
0002H	Undervoltage (Uv1)	000CH	Drive Overload (oL2)
0003H	Control Power Supply Undervoltage (Uv2)	000DH	Overtorque Detection 1 (oL3)
0004H	Soft Charge Circuit Fault (Uv3)	0010H	Braking Resistor Overheat (rH)
0006H	Ground Fault (GF)	0011H	External Fault at Input Terminal S3 (EF3)
0007H	Overcurrent (oC)	0012H	External Fault at Input Terminal S4 (EF4)
0008H	Overvoltage (ov)	0013H	External Fault at Input Terminal S5 (EF5)
0009H	Heatsink Overheat (oH)	0014H	External Fault at Input Terminal S6 (EF6)
000AH	Heatsink Overheat (oH1)	0015H	External Fault at Input Terminal S7 (EF7)
000BH	Motor Overload (oL1)	001BH	Input Phase Loss (PF)

Fault Code	Fault Name
001CH	Output Phase Loss (LF)
001DH	Motor Overheat (PTC input) (oH3)
001EH	Digital Operator Connection (oPr)
001FH	EEPROM Write Error (Err)
0020H	Motor Overheat (PTC input) (oH4)
0021H	MEMOBUS/Modbus Communication Error (CE)
0022H	Option Communication Error (bUS)
0027H	Option External Fault (EF0)
0028H	PI Feedback Loss (FbL)
0029H	Undertorque Detection 1 (UL3)
002BH	High Slip Braking Overload (oL7)
0030H	Hardware Fault (including oFx)
0036H	Output Current Imbalance (LF2)
0037H	Pullout Detection (Sto)
003BH	Too Many Speed Search Restarts (SEr)
0041H	PI Feedback Loss (FbH)
0042H	External Fault 1, Input Terminal S1 (EF1)
0043H	External Fault 2, Input Terminal S2 (EF2)
0046H	Current Offset Fault (CoF)
0047H	PLC Detection Error 1 (PE1)
0048H	PLC Detection Error 2 (PE2)
004DH	Output Voltage Detection Fault (voF)
0052H	Node Setup Fault (nSE)
005AH	Motor Underload Protection (UL6)
0083H	A/D Conversion Error (CPF02)
0084H	PWM Data Fault (CPF03)
0087H	EEPROM Memory Data Error (CPF06)
0088H	Terminal Board Connection Error (CPF07)
0089H	EEPROM Serial Communication Fault (CPF08)
008CH	RAM Fault (CPF11)
008DH	Flash Memory Circuit Exception (CPF12)
008EH	Watchdog Circuit Exception (CPF13)
008FH	Control Circuit Fault (CPF14)
0091H	Clock Fault (CPF16)
0092H	Timing Fault (CPF17)
0093H	Control Circuit Fault (CPF18)
0094H	Control Circuit Fault (CPF19)
0095H	Hardware Fault at Power Up (CPF20)
0096H	Hardware Fault at Communication Start Up (CPF21)
0097H	A/D Conversion Fault (CPF22)
0098H	PWM Feedback Fault (CPF23)
0099H	Drive Unit Signal Fault (CPF24)
009AH	Terminal Board is Not Properly Connected. (CPF25)
009BH	ASIC BB Circuit Error (CPF26)
009CH	ASIC PWM Setting Register Error (CPF27)
009DH	ASIC PWM Pattern Error (CPF28)

Fault Code	Fault Name
009EH	ASIC On-delay Error (CPF29)
009FH	ASIC BBON Error (CPF30)
00A0H	ASIC Code Error (CPF31)
00A1H	ASIC Start-up Error (CPF32)
00A2H	Watch-dog Error (CPF33)
00A3H	ASIC Power/Clock Error (CPF34)
00A4H	External A/D Converter Error (CPF35)
00A9H	Control Circuit Error (CPF40)
00AAH	Control Circuit Error (CPF41)
00ABH	Control Circuit Error (CPF42)
00ACH	Control Circuit Error (CPF43)
00ADH	Control Circuit Error (CPF44)
00AEH	Control Circuit Error (CPF45)
0101H	Option Compatibility Error (oFA00)
0102H	Option Not Properly Connected (oFA01)
0106H	A/D Conversion Error (oFA05)
0107H	Option Response Error (oFA06)
0111H	Option RAM Fault (oFA10)
0112H	Option Operation Mode Fault (SLMOD) (oFA11)
0113H	Drive Receive CRC Error (oFA12)
0114H	Drive Receive Frame Error (oFA13)
0115H	Drive Receive Abort Error (oFA14)
0116H	Option Receive CRC Error (oFA15)
0117H	Option Receive Frame Error (oFA16)
0118H	Option Receive Abort Error (oFA17)
0131H	Comm. ID Error (oFA30)
0132H	Model Code Error (oFA31)
0133H	Sumcheck Error (oFA32)
0134H	Comm. Option Timeout Waiting for Response (oFA33)
0135H	MEMOBUS Timeout (oFA34)
0136H	Drive Timeout Waiting for Response (oFA35)
0137H	CI Check Error (oFA36)
0138H	Drive Timeout Waiting for Response (oFA37)
0139H	Control Command Selection Error (oFA38)
013AH	Drive Timeout Waiting for Response (oFA39)
013BH	Control Response Selection 1 Error (oFA40)
013CH	Drive Timeout Waiting for Response (oFA41)
013DH	Control Response Selection 2 Error (oFA42)
013EH	Control Response Selection Error (oFA43)
0401H	Time Not Set (TIM)
0402H	Operator Battery Low (bAT)
0403H	Time Data Error (TdE)
0404H	Time Interval Error (TiE)
0405H	Overvoltage 2 (ov2)
0407H	External Fan Fault (Fn1)

### ◆ Bypass Fault Codes

*Table D.4* shows the bypass fault codes that can be read out by MEMOBUS/Modbus commands from the UB-□□ monitor parameters.

**Table D.4 Bypass fault Codes**

Fault Code	Fault Name	Fault Code	Fault Name
0001H	Safety Open	0008H	PL Brownout
0002H	BAS InterLock Open	0009H	PL Blackout
0003H	External Fault (EFB)	000AH	No Bypass to Drive Communications
0004H	NA	000BH	Bypass Board Hardware Error
0005H	Motor Overload	000CH	Option Board Communication Fault
0006H	Ext Motor1 Overload	000DH	Loss of Load
0007H	Ext Motor2 Overload	000EH	Serial Communications Timeout

### ◆ Alarm Register Contents

The table below shows the alarm codes that can be read out from MEMOBUS/Modbus register 007FH.

**Table D.5 Alarm Register 007FH Contents**

Fault Code	Fault Name	Fault Code	Fault Name
0001H	Undervoltage (Uv)	0028H	PI Feedback Loss (FbH)
0002H	Overvoltage (ov)	002AH	Drive Disabled (dnE)
0003H	Heatsink Overheat (oH)	0031H, 0033H	Reserved
0004H	Overheat Signal from MFDI (oH2)	0034H	High Current Alarm (HCA)
0005H	Overtorque 1 (oL3)	0035H	Cooling Fan Maintenance Time (LT-1)
0007H	Run commands input error (EF)	0036H	Capacitor Maintenance Time (LT-2)
0008H	Drive Baseblock (bb)	0038H	Reserved
0009H	External Fault 3, input terminal S3 (EF3)	0039H	External Fault (input terminal S1) (EF1)
000AH	External Fault 4, input terminal S4 (EF4)	003AH	External Fault (input terminal S2) (EF2)
000BH	External Fault 5, input terminal S5 (EF5)	003FH	PLC Alarm (PA1)
000CH	External Fault 6, input terminal S6 (EF6)	0040H	PLC Alarm (PA2)
000DH	External Fault 7, input terminal S7 (EF7)	0041H	Output Voltage Detection Fault (voF)
000FH	Internal Fan Fault (FAn)	004EH	Motor Underload Protection (UL6)
0014H	MEMOBUS/Modbus Communication Error (CE)	004FH	Waiting for Run (WrUn)
0015H	Option Communication Error (bUS)	0063H	Time Not Set (TIM)
0017H	Motor Overload (oL1)	0064H	Operator Battery Low (bAT)
0018H	Drive Overload (oL2)	0065H	Time Data Error (TdE)
001AH	Option Card External Fault (EF0)	0066H	External Fan Fault (Fn1)
001DH	Serial Communication Transmission Error (CALL)	0067H	Emergency Override Forward Run (EoF)
001EH	Undertorque Detection 1 (UL3)	0068H	Emergency Override Reverse Run (Eor)
0020H	MEMOBUS/Modbus Test Mode Fault (SE)	006AH	Customer Safety (SAFE)
0022H	Motor Overheat (oH3)	006BH	Interlock Open (inTLK)
0027H	PI Feedback Loss (FbL)		

## D.10 Enter Command

When writing parameters to the bypass from the PLC using MEMOBUS/Modbus communication, parameters become active immediately. If it is desired to save the parameter value to non-volatile memory, then a separate Enter command must be given. This section describes the Enter command.

The bypass supports the Enter command as shown in [Table C.10](#). An Enter command is enabled by writing 0 to register number 0900H. It is only possible to write to this register; attempting to read from this register will cause an error.

**Table D.6 Enter Command**

Register No.	Description
0900H	Simultaneously writes data into the EEPROM (non-volatile memory) of the bypass and enables the data in RAM. Parameter changes remain after cycling power.

**Note:** The EEPROM can only be written to 100,000 times, so it is recommended to limit the number of times writing to the EEPROM. The Enter command register is write-only and if this register is read, the register address will be invalid (Error code: 02H). An Enter command is not required when reference or broadcast data are sent to the drive.

### ◆ Enter Command Behavior

An enter command is not required when writing registers 0000H to 001FH and 8400H to 83FFH. Changes to those registers cannot be saved to non-volatile memory.

Enter Conditions	Behavior
How parameter settings are enabled	As soon as the value is changed.
Upper/lower limit check	Checks only the upper/lower limits of the parameters that were changed.
Default value of related parameters	Default settings of related parameters are changed automatically.
Error handling when setting multiple parameters	Error occurs if only one setting is invalid. All data that was sent are discarded.

## D.11 Communication Errors

### ◆ MEMOBUS/Modbus Error Codes

A list of MEMOBUS/Modbus errors appears below.

When an error occurs, remove whatever caused the error and restart communications.

Error Code	Error Name
	Cause
01H	Function Code Error
	Attempted to set a function code from a PLC other than 03H, 08H, and 10H.
02H	Register Number Error
	<ul style="list-style-type: none"> <li>• A register number specified in the command message does not exist.</li> <li>• Attempted to send a broadcast message using other register numbers than 0001H or 0002H.</li> </ul>
03H	Bit Count Error
	<ul style="list-style-type: none"> <li>• Read data or write data is greater than 16 bits. Invalid command message quantity.</li> <li>• In a write message, the “Number of Data Items” contained within the message does not equal twice the amount of data words (i.e., the total of Data 1+ Data 2, etc.).</li> </ul>
21H	Data Setting Error
	<ul style="list-style-type: none"> <li>• Control data or parameter write data is outside the allowable setting range.</li> <li>• Attempted to write a contradictory parameter setting.</li> </ul>
22H	Write Mode Error
	<ul style="list-style-type: none"> <li>• During run, the user attempted to write a parameter that cannot be written to during run.</li> <li>• During an EEPROM memory data error (CPF06), the master attempted to write to a parameter other than A1-00 to A1-05, E1-03, or o2-04.</li> <li>• Attempted to write to read-only data.</li> </ul>
23H	DC Bus Undervoltage Write Error
	During an undervoltage situation, the master attempted to write to parameters that cannot be written to during undervoltage.
24H	Write Error During Parameter Process
	Master attempted writing to the drive while the drive was processing parameter data.
25H	Writing into EEPROM Disabled
	An attempt was made to write data into EEPROM by MEMOBUS/Modbus communications when writing EEPROM is not possible. (When this error code occurs, an error message is displayed and the drive continues operation.)

### ◆ Slave Not Responding

In the following situations, the slave drive will ignore the command message sent from the master, and not send a response message:

- When a communications error (overrun, framing, parity, or CRC-16) is detected in the command message.
- When the slave address in the command message and the slave address in the drive do not match (remember to set the slave address for the drive using Z3-02).
- When the gap between two blocks (8-bit) of a message exceeds 24 bits.
- When the command message data length is invalid.

**Note:** If the slave address specified in the command message is 00H, all slaves execute the write function, but do not return response messages to the master.

# Appendix: E

## Apogee FLN Network Protocol

---

This appendix explains the specifications and handling of the APOGEE FLN protocol for the Yaskawa Z1000 Bypass. The APOGEE FLN protocol connects the Z1000 Bypass to an APOGEE FLN network and facilitates the exchange of data.

<b>E.1</b>	<b>APOGEE FLN SET-UP.....</b>	<b>424</b>
<b>E.2</b>	<b>CONNECTING TO A NETWORK.....</b>	<b>425</b>
<b>E.3</b>	<b>SLOPE AND INTERCEPT CONVERSION.....</b>	<b>427</b>
<b>E.4</b>	<b>APOGEE FLN POINT LIST SUMMARY.....</b>	<b>429</b>
<b>E.5</b>	<b>CABLE LOSS CONFIGURATION AND BEHAVIOR.....</b>	<b>433</b>
<b>E.6</b>	<b>MAILBOX FUNCTION.....</b>	<b>435</b>
<b>E.7</b>	<b>FAULT CODES.....</b>	<b>436</b>

### E.1 APOGEE FLN Set-Up

A Yaskawa America representative is responsible for proper configuration of the Bypass for its primary application, while a Siemens Building Technologies representative is responsible for field panel programming to make use of the Bypass functionality in the building automation system. As such, there must be coordination between the Yaskawa America and Siemens Building Technologies representatives to ensure that the programming of the drive is consistent with the particular application requirements. After verifying that the drive installation and wiring are correct, apply power to the drive. [Refer to Drive Communication Parameter Settings on page 424](#) lists parameters and values required for proper APOGEE FLN communication and control.

#### ◆ Z1000 Bypass Parameter Settings for APOGEE FLN Communications

Table E.1 Drive Communication Parameter Settings

Parameter Number	Digital Operator Display	Settings for APOGEE FLN Communication
Z1-07	Reference Source	2: Serial Com
Z1-08	Run Source	2: Serial Com
Z3-02	Serial Comm Adr	Select the Bypass address
Z3-03	Serial Baud Rate	2: 4800 Baud
Z3-01	Protocol Select	2: P1

**NOTICE:** A Yaskawa representative should set the drive parameters to their appropriate values. Changes made to the parameters other than what is listed in the table above can result in damaging the drive or building equipment.



## E.2 Connecting to a Network

### ◆ Network Cable Connection

Follow the instructions below to connect the bypass to a MEMOBUS/Modbus network.

**Note:** Separate the communication cables from the main circuit cables and other wiring and power cables. Use shielded cables for the communication cables and properly shielded clamps to prevent problems from electrical interference.

- With the power shut off, connect the communications cable to the bypass controller and the master. Use the terminal TB3 for MEMOBUS/Modbus.

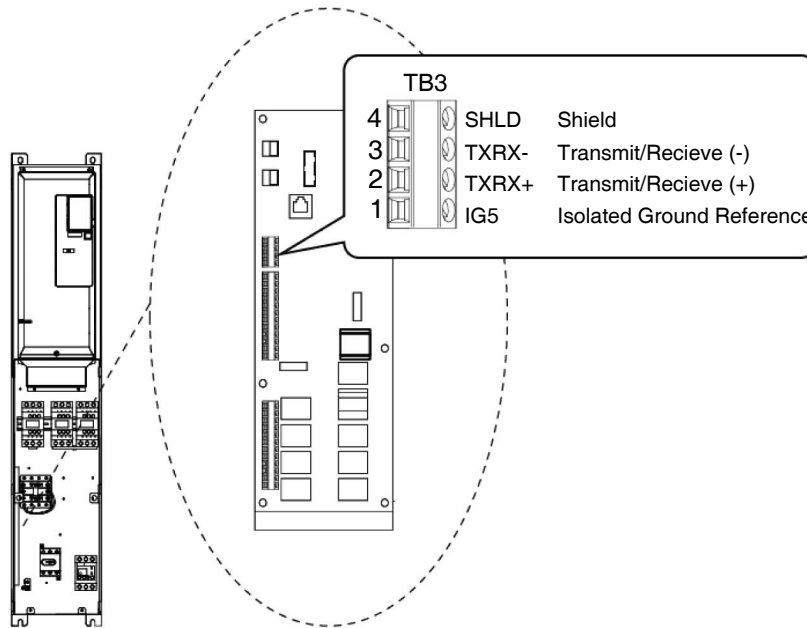
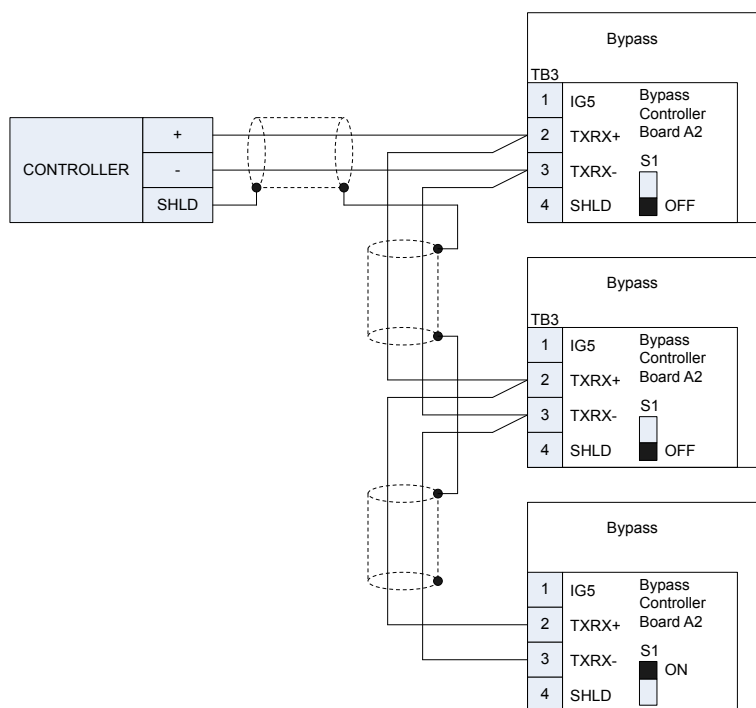

Figure E.1 Serial Communications Cable Connection Terminal (TB3)

- Check or set the termination resistor selection at all slaves. [Refer to Network Termination on page 379](#) for slaves that are Z1000 Bypasses.
- Apply power.
- Set parameters Z3-01 to Z3-11 needed for serial communications using the HOA keypad.
- Remove power and wait for the display on the HOA keypad to go blank.
- Reapply power.
- The bypass is now ready to begin communicating with the master.

### ◆ Wiring Diagram for Multiple Connections

#### ■ RS-485 Interface



**Figure E.2 Connection Diagram for Multiple Connections**

**Note:** Turn on DIP switch S1 on the bypass controller located at the end of the network. If DIP switch S1 is missing place an external 120 ohm resistor across terminals TXRX+ and TXRX-. All other slave devices must have this DIP switch set to the OFF position (or if S1 is missing, no external resistor is used).

### ◆ Network Termination

The two ends of the P1 network line have to be terminated with a 120 ohm resistor between the TXRX+ and TXRX- signals. The Z1000 Bypass has a built in termination resistor that can be enabled or disabled using DIP switch S1. If a bypass is located at the end of a network line, enable the termination resistor by setting DIP switch S1 to the ON position. Disable the termination resistor on all slaves that are not located on the network line end.

**Note:** Some bypass controllers do not have DIP switch S1. If this is the case, place an external 120 ohm resistor across the TXRX+ and TXRX- signals if the bypass controller is at the end of a network line.

### ◆ Recommended Cable

**Table E.2 APOGEE FLN Cable Specifications**

Specification	Description
Cable Configuration	Twisted Shielded Pair
Gauge	18-20 AWG (Solid or Stranded)
Wire Lay	6 twists per foot
Shields	100% foil with drain wire
NEC Type	UL Type CMP
Temperature	60 °C or higher

## E.3 Slope and Intercept Conversion

Several drive parameters are available for monitoring purposes. These include FREQ OUTPUT (Point 3), SPEED (Point 5), CURRENT (Point 6), TORQUE (Point 7), POWER (Point 8), DRIVE TEMP (Point 9), KWH (Point 10), and RUN TIME (Point 12). These points can be unbundled for monitoring or used in various global control strategies.

### ◆ Drive Controlled Feedback

The most typical application is Supervisory Control. The sensor for the control variable (e.g., water temperature) is hard-wired to the drive and the control device (fan) is modulated using the PI control loop that is built into the drive. The setpoint for the control variable (water temperature setpoint) is unbundled and commanded by the field panel, based on some building control strategy implemented in PPCL.

When this strategy is used, the point to unbundle and command for the setpoint is INPUT REF 1 (Point 60). The control variable (e.g., water temperature) can be monitored by unbundling PI FEEDBACK (Point 62). These points are provided in units of percent, where 0% and 100% correspond to the range of the sensor being used to measure the control variable. These points have default units in Hz. If other units are required, unbundle these points with appropriate slopes and intercepts. The new intercept will be equal to the lowest value of the desired range. You can define a new slope and intercept using the formula below to convert the units:

$$\text{New Slope} = \frac{(\text{Desired Range}) \times (\text{Slope of Existing Point})}{(\text{Range of Existing Point})}$$

$$\text{New Slope} = \frac{(60 - 0)\text{Hz} \times (0.01)}{(100 - 0)\%} = 0.006$$

### Conversion Example

You are controlling water temperature from a cooling tower using the drive to control a fan. The temperature sensor has a range of 30 °F to 250 °F. To unbundle the setpoint (INPUT REF 1), for commanding in degrees Fahrenheit, where 0 to 60 Hz is equal to 30 °F to 250 °F:

New Intercept = 30 (the temperature that corresponds to 0%)

$$\text{New Slope} = \frac{(\text{Desired Range}) \times (\text{Slope of Existing Point})}{(\text{Range of Existing Point})}$$

$$\text{New Slope} = \frac{(250 - 30)\text{°F} \times (0.1)}{(100 - 0)\%} = 0.022$$

Formula Notes:

Desired Range = Range Maximum – Range Minimum

Range of Existing Point = Existing Range Maximum – Existing Range Minimum

### ◆ Field Panel Controlled Feedback

In this strategy, the sensor is connected to the APOGEE FLN network at a remote location, and the control loop is executed in PPCL. The drive speed command is passed from the field panel to the drive by commanding INPUT REF 1 (Point 60).

**NOTICE:** *This strategy is not recommended because the loop is being closed over the network. Delays from processor scan time and network traffic can cause degradation or loss of control. Damage to HVAC equipment may result.*

Unbundle the FEEDBACK

To unbundle the feedback (PI FEEDBACK) for monitoring in degrees Fahrenheit:

New Intercept = 30

$$\text{New Slope} = \frac{(\text{Desired Range}) \times (\text{Slope of Existing Point})}{(\text{Range of Existing Point})}$$

$$\text{New Slope} = \frac{(250 - 30)\text{°F} \times (0.1)}{(100 - 0)\%} = 0.022$$

Formula Notes:

Desired Range = Range Maximum – Range Minimum

Range of Existing Point = Existing Range Maximum – Existing Range Minimum

### ◆ Other Functionality

Each of the following functions must be enabled during drive startup:

#### **Enable the drive to run**

RUN ENABLE (Point 35) can be commanded to require the drive to have a physical input (DI-2) set before the drive can run. This works in conjunction with CMD RUN.STOP (Point 24) or the CMD REV.STOP (Point 22). If RUN ENABLE (Point 35) is commanded ON then terminal for DI-2 does not need to be on and CMD RUN.STOP (Point 24) or CMD REV.STOP (point 22) needs to be commanded ON for the drive to run. If, on the other hand, RUN ENABLE (Point 35) is commanded OFF, then to run the drive the input terminal for DI-3 needs to be on and either CMD RUN.STOP (Point 24) or CMD REV.STOP (Point 22), needs to be commanded ON.

#### **Start and stop the drive**

CMD RUN.STOP (Point 24) can be commanded to run the Bypass in the forward direction. STOP.RUN (Point 23) shows the current status of the Bypass.

#### **Change directions**

CMD REV.STOP (Point 22) can be commanded to run the drive in the reverse direction (ignored in Bypass Mode). FWD.REV (Point 21) shows the current direction of the drive rotation.

**NOTICE:** *Improper drive direction may damage HVAC equipment if parameter b1-04, Reverse Enable, is improperly set (b1-04 = 0).*

#### **Digital Outputs**

MULTI OUT 1 (Point 40), MULTI OUT 2 (Point 41), and MULTI OUT 3 (Point 42) are physical digital outputs on the Bypass (DO-7 through DO-9). Their purpose depends on how the Bypass has been set-up. The Bypass can be programmed so that these points can display various limits, warnings, and status conditions. Some examples include HOA state, Drive or Bypass Mode, Fault Active, and Loss of Load detected.

#### **Loop gain**

PID P GAIN (Point 63) and PID I TIME (Point 64) are the gain and integral time parameters similar to the P and I gains in the APOGEE Terminal Equipment Controllers. The Z1000 Bypass's PI loop is structured differently than the Siemens loop, so there is not a one-to-one correspondence between the gains.

#### **Reading and resetting faults**

OK.FAULT (Point 93) shows the current status of the Bypass. FAULT CODE (Point 17) contains the code for the most current fault. LST FLT CODE (Point 66) contains the code for the previous drive fault. See table below for descriptions of the fault codes. The drive can be reset back to OK mode by commanding RESET FAULT (Point 94) to RESET.

## E.4 APOGEE FLN Point List Summary

This database is for APOGEE FLN Application 2721 and features 97 logical points: 29 Logical Analog Inputs (LAI), 35 Logical Analog Outputs (LAO), 19 Logical Digital Inputs (LDI) and 14 Logical Digital Outputs (LDO). These points configure, control or monitor the operation of the drive.

Information to consider when referencing this table:

- Points not listed are not used in this application.
- A single value in a column means that the value is the same in English units and in SI units.
- Point numbers that appear in curly brackets, e.g. {03}, can be unbundled at the field panel.

Table E.3 APOGEE FLN Application 2721 Point Number Summary

Point No.	Point Type	Point Name	Factory Default (SI Units)	Engr. Units (SI Units)	Slope (SI Units)	Intercept (SI Units)	On Text	Off Text	Z1000 Parameter
1	LAO	CTLR ADDRESS	31	–	1	0	–	–	Z3-02
2	LAO	APPLICATION	–	–	1	0	–	–	–
{03}	LAI	FREQ OUTPUT	0	HZ	0.01	0	–	–	U1-02
{04}	LAI	PCT OUTPUT	0	PCT	0.01	0	–	–	–
{05}	LAI	SPEED	0	RPM	1	0	–	–	–
{06}	LAI	CURRENT	0	AMPS (A)	0.01/0.1 <>	0	–	–	UB-01
{07}	LAI	TORQUE	0	PCT	0.1	0	–	–	–
{08}	LAI	POWER	0	KW	0.01/0.1 <>	0	–	–	U1-08
{09}	LAI	DRIVE TEMP	0	DEG F / C	1	0	–	–	U4-08 <>
{10}	LAI	DRIVE KWH	0	KWH	0.1	0	–	–	U4-10
{11}	LAI	MWH	0	MWH	1	0	–	–	U4-11
{12}	LAI	RUN TIME	0	HRS	1	0	–	–	U4-01
{13}	LAI	DC BUS VOLT	0	VOLTS (V)	1	0	–	–	U1-07
{14}	LAI	AC OUT VOLT	0	VOLTS (V)	0.1	0	–	–	U1-06
15	LAI	PAR N9.01	0	AMPS (A)	0.01/0.1 <>	0	–	–	n9-01
{16}	LAI	RUN TIMEX10K	0	10K HR	1	0	–	–	U4-01
{17}	LAI	FAULT CODE	0	–	1	0	–	–	U2-01/ UB-09
{18} <>	LDI	MINOR FLT	NO FLT	–	1	0	FAULT	NO FLT	U1-12 (Bit 6)
{19}	LDI	MAJOR FLT	NO FLT	–	1	0	FAULT	NO FLT	UB-06 (Bit 2)
20	LAO	OVRD TIME	1	HRS	1	0	–	–	–
{21}	LDI	FWD.REV	FWD	–	1	0	REV	FWD	U1-12 (Bit 2)
{22}	LDO	CMD REV.STOP	STOP	–	1	0	REV	STOP	–
{23}	LDI	RUN.STOP	STOP	–	1	0	RUN	STOP	UB-06 (Bit 1)
{24}	LDO	CMD RUN.STOP	STOP	–	1	0	FWD	STOP	–
{25}	LDI	ZERO SPEED	OFF	–	1	0	ON	OFF	U1-12 (Bit 1)
{26}	LDI	SPEED AGREE	NO AGR	–	1	0	AGREE	NO AGR	U1-12 (Bit 4)
{27}	LDI	DRIVE READY	NOTRDY	–	1	0	READY	NOTRDY	U1-12 (Bit 5)

## E.4 APOGEE FLN Point List Summary

Point No.	Point Type	Point Name	Factory Default (SI Units)	Engr. Units (SI Units)	Slope (SI Units)	Intercept (SI Units)	On Text	Off Text	Z1000 Parameter
{28}	LDI	LOC.REM MON	REMOTE	–	1	0	LOCAL	REMOTE	UB-05
{29}	LDO	DAY.NGT	DAY	–	1	0	NGT	DAY	–
30	LAO	CURRENT LMT	0	AMPS (A)	0.01/0.1 </>	0	–	–	E2-01
31	LAO	ACCEL TIME	0	SEC	0.1	0	–	–	C1-01
32	LAO	DECEL TIME	0	SEC	0.1	0	–	–	C1-02
33	LDO	LOCK PANEL	UNLOCK	–	1	0	LOCK	UNLOCK	–
35 </>	LDO	RUN ENABLE	STOP	–	1	0	ENABLE	STOP	Bypass DI-2
36	LAO	STALL PRE RN	90	PCT	1	30	–	–	L3-06
37	LAO	STALL PRE AC	120	PCT	1	0	–	–	L3-02
38	LAO	FREQ UP LIM	100	PCT	0.1	0	–	–	d2-01
39	LAO	FREQ LOW LIM	0	PCT	0.1	0	–	–	d2-02
{40}	LDI	MULTI OUT 1	OFF	–	1	0	ON	OFF	UB-03 (Bit 6) Bypass DO-7
{41}	LDI	MULTI OUT 2	OFF	–	1	0	ON	OFF	UB-03 (Bit 7) Bypass DO-8
{42}	LDI	MULTI OUT 3	OFF	–	1	0	ON	OFF	UB-03 (Bit 8) Bypass DO-9
{43}	LDI	SAFETY ILOCK	OFF	–	1	0	ON	OFF	UB-05 (Bit 7)
{44} </>	LDO	MF INP 1	OFF	–	1	0	ON	OFF	Bypass DI-3
{45} </>	LDO	MF INP 2	OFF	–	1	0	ON	OFF	Bypass DI-4
{46} </>	LDO	MF INP 3	OFF	–	1	0	ON	OFF	Bypass DI-5
{47} </>	LDO	MF INP 4	OFF	–	1	0	ON	OFF	Bypass DI-6
{48} </>	LDO	MF INP 5	OFF	–	1	0	ON	OFF	Bypass DI-7
49	LAO	JUMP FREQ 1	0	HZ	0.1	0	–	–	d3-01
50	LAO	JUMP FREQ 2	0	HZ	0.1	0	–	–	d3-02
51	LAO	JUMP FREQ 3	0	HZ	0.1	0	–	–	d3-03
52	LAO	JUMP FREQ BW	0	HZ	0.1	0	–	–	d3-04
53	LAO	NUM AUTOSTRT	0	–	1	0	–	–	L5-01
54	LAO	POWER LOSS RT	0.1	SEC	0.1	0	–	–	L2-02
55	LAO	RUN OP MODE	1	–	1	0	–	–	Z1-08
56	LAO	REF OP MODE	1	–	1	0	–	–	Z1-07
57	LAO	OPER DISP MD	0	–	1	0	–	–	o1-03
{58}	LDI	MF IN 1 MON	OFF	–	1	0	ON	OFF	UB-02 (Bit 2) Bypass DI-3
{59}	LDI	MF IN 2 MON	OFF	–	1	0	ON	OFF	UB-02 (Bit 3) Bypass DI-4

## E.4 APOGEE FLN Point List Summary

Point No.	Point Type	Point Name	Factory Default (SI Units)	Engr. Units (SI Units)	Slope (SI Units)	Intercept (SI Units)	On Text	Off Text	Z1000 Parameter
{60}	LAO	INPUT REF 1	0	HZ	0.01	0	–	–	–
61	LAO	INPUT REF 2	0	HZ	0.01	0	–	–	d1-02
{62}	LAI	PID FEEDBACK	0	PCT	0.01	0	–	–	U5-01
63	LAO	PID P GAIN	2	–	0.01	0	–	–	b5-02
64	LAO	PID I TIM	0.5	SEC	0.1	0	–	–	b5-03
65	LDO	PID MODE SEL	DISABLE	–	1	0	ENABLE	DISABLE	b5-01
{66}	LAI	LST FLT CODE	0	–	1	0	–	–	U2-02
{67}	LAI	FREF.FLT	0	HZ	0.01	0	–	–	U2-03
{68}	LAI	OUT FREQ FLT	0	HZ	0.01	0	–	–	U2-04
{69}	LAI	OUT CUR.FLT	0	AMPS (A)	0.01	0	–	–	U2-05
70	LAO	RD PARAM NUM	1	–	1	0	–	–	–
71	LAI	RD PARAM DAT	0	–	1	0	–	–	–
72	LAO	WR PARAM NUM	1	–	1	0	–	–	–
73	LAO	WR PARAM DAT	0	–	1	0	–	–	–
{74}	LDI	MF IN 3 MON	OFF	–	1	0	ON	OFF	UB-02 (Bit 4) Bypass DI-5
{75}	LAI	OUT VOLT.FLT	0	VOLTS (V)	0.1	0	–	–	U2-07
{76}	LAI	DC BUS.FLT	0	VOLTS (V)	1	0	–	–	U2-08
{77}	LAI	OUT PWR.FLT	0	KW	0.1	0	–	–	U2-09
{78}	LDI	MF IN 4 MON	OFF	–	1	0	ON	OFF	UB-02 (Bit 5) Bypass DI-6
{79}	LAI	PID DEVIATE	0	PCT	0.01	0	–	–	U5-02
80	LAO	PID I LIMIT	100	PCT	0.1	0	–	–	b5-04
81	LAO	PID UP LIMIT	100	PCT	0.1	0	–	–	b5-06
82	LAO	PID OFFS ADJ	100	PCT	0.1	-100	–	–	b5-07
83	LAO	PID PRI DYTM	0	SEC	0.1	0	–	–	b5-08
84	LAO	PID FB RMDS	0	–	1	0	–	–	b5-12
85	LAO	PID FB RMDL	0	PCT	1	0	–	–	b5-13
86	LAO	PID FB RMDT	1	SEC	0.1	0	–	–	b5-14
{87}	LAI	PID OUT CAP	0	PCT	0.01	0	–	–	U5-14
{88}	LAI	PID REF	0	PCT	0.01	0	–	–	U5-04
{89}	LAI	COMM ERR CD	0	–	1	0	–	–	U1-19
90	LDO	COMM FLT ENA	ENABLE	–	1	0	ENABLE	DISABLE	Z3-11

## E.4 APOGEE FLN Point List Summary

Point No.	Point Type	Point Name	Factory Default (SI Units)	Engr. Units (SI Units)	Slope (SI Units)	Intercept (SI Units)	On Text	Off Text	Z1000 Parameter
91	LAO	CBL LOSS FRQ	0	HZ	0.01	0	–	–	Z3-10
92	LAO	CBL LOSS TMR	2	SEC	0.1	0	–	–	Z3-06
{93}	LDI	OK.FAULT	OK	–	1	0	FAULT	OK	UB-06 (Bit 2)
{94}	LDO	RESET FAULT	NO	–	1	0	RESET	NO	–
{95}	LDI	DRV COMM ERR	NO FLT	–	1	0	FAULT	NO FLT	–
{96}	LDO	EXTERNAL FLT	OK	–	1	0	FAULT	OK	–
{97}	LDI	MF IN 5 MON	OFF	–	1	0	ON	OFF	UB-02 (Bit 6) Bypass DI-7
{99}	LAI	ERROR STATUS	0	–	1	0	–	–	–

- <1> In bypass controller software versions VST800298 and later, the number of decimal places in the value depends on the bypass model. This value has two decimal places in models Z1B1D002 to Z1B1D031 and Z1B1B001 to Z1B1B014; this value has one decimal place in models Z1B1D046 to Z1B1D273 and Z1B1B021 to Z1B1B302.
- <2> Will only report accurately when drive is running.
- <3> Point LDI 18 displays both drive alarms and bypass alarms in bypass controller software versions VST800298 and later.
- <4> Set Z2-02 to 22 (Run Enable) for point 35 to work properly.
- <5> Disabled when Z3-12 is set to 0 in bypass controller software versions VST800298 and later.



## E.5 Cable Loss Configuration and Behavior

This section describes the configurable cable loss feature of the drive. This feature offers a user maximum flexibility in determining drive response to a loss of communication.

### ◆ Drive Behavior at Loss of Communication

After some interval without receipt of a message, the drive can be configured to respond in one of the following manners:

- Continue at last speed
- Continue at last speed with Alarm
- Continue at preset speed
- Ramp to Stop with FB14 fault
- Coast to Stop with FB14 fault
- Emergency Stop with FB14 fault

### ◆ Apogee FLN Points

Three APOGEE FLN points are used to select the desired behavior:

- **POINT 92** – CBL LOSS TMR
- **POINT 91** – CBL LOSS FRQ
- **POINT 90** – COMM FLT ENA

Table E.4 Cable Loss Behavior Summary

Behavior	F6-03	Z3-05	CBL LOSS TMR (Point 92)	CBL LOSS FRQ (Point 91)	COMM FLT ENA (Point 90)
Decelerate to stop (stop time in C1-02) <b>FB14 Fault.</b> <b>Note:</b> In Bypass Mode, bypass contactor will open and motor will coast to stop.	0	3	Timeout Interval	X	On
Coast to stop <b>FB14 Fault.</b> <b>Note:</b> In Bypass Mode, bypass contactor will open and motor will coast to stop.	1	3	Timeout Interval	X	On
Fast stop (stop time in C1-09) <b>FB14 Fault.</b> <b>Note:</b> In Bypass Mode, bypass contactor will open and motor will coast to stop.	2	3	Timeout Interval	X	On
Continue at last speed	3	0	0	X	X
Continue at last speed with Alarm	3	1	Timeout Interval	X	On
Continue at preset speed with Alarm	3	4	Timeout Interval	Preset Speed	On
<b>Note:</b>	<ol style="list-style-type: none"> <li>1. Communication must first be established and then lost for these features to function as described. If a Bypass is powered-up without a cable connected or with the master controller offline, a communications timeout does not occur.</li> <li>2. For modes which describe the Bypass running after a communications timeout, a run command must have been issued (RUN ENABLE (Point 35) = 'On' and either CMD RUN.FWD (Point 22) = 'On' or CMD RUN.REV (Point 24) = 'On') prior to loss of communications. For safety purposes, the drive will not automatically restart from a stopped condition. If a user requires the drive to restart automatically, additional external wiring is required to accomplish this (consult factory).</li> </ol> <p>Upon expiration of the communications timeout interval, a CE (Communication Error) fault will be declared and will remain until communication is restored.</p>				

#### Continue at Last Speed

In this mode, CBL LOSS TMR (POINT 92) is set to 0, disabling the cable loss feature. The other two settings CBL LOSS FRQ (POINT 91) and COMM FLT ENA (POINT 90) are ignored. If communication is lost, the drive maintains its last commanded state. The drive will not display an alarm or fault to indicate it has lost communication. This behavior can also be achieved by setting parameter Z3-05 to 0.

## E.5 Cable Loss Configuration and Behavior

---

### Continue at Last Speed with Alarm

For this condition, COMM FLG ENA (Point 90) must be enabled and CBL LOSS TMR (Point 91) should be set to something other than 0. An AL14 Serial Communications Alarm is shown.

### Continue at Preset Speed with Alarm

In this mode, CBL LOSS TMR (POINT 92) is set to the desired interval, CBL LOSS FRQ (POINT 91) is set to the desired preset speed and Z3-05 is set to 4. If the time between messages exceeds the timeout interval, the drive speed command, INPUT REF 1, (Point 60) is set to the CBL LOSS FRQ (POINT 91) and the drive continues running at this new speed. COMM FLT ENA (POINT 90) must be set to ON.

### Stop with Fault (FB14)

COMM FLT ENA (POINT 90) must be set to ON. In this mode, CBL LOSS TMR (POINT 92) is set to the desired interval and parameter F6-03 is set to a value of 0,1, or 2. If the time between messages exceeds the timeout interval, the drive speed command, INPUT REF 1, (Point 60) is set to 0. The stopping method is determined by the setting of F6-03. An FB14 drive fault will be set and an EF0 will be sent to the drive. The drive behavior is determined by the setting of parameter F6-03.

- F6-03 = 0 selects Ramp to Stop. The deceleration time or the slope of the ramp is determined by the setting of drive parameter C1-02.
- F6-03 = 1 selects Coast to Stop. The drive does not attempt to control the rate of deceleration.
- F6-03 = 2 selects Fast Stop. The deceleration time is determined by the setting of drive parameter C1-09.

## E.6 Mailbox Function

### ◆ Mailbox Function Points

#### ■ Reading a Drive Parameter

Two points are defined for reading any drive parameter:

- Point 70 specifies the parameter to be read from
- Point 71 reports the value of the parameter specified in Point 70

When this point is read, it retrieves data from the parameter and sends it to the controller.

Example:

Writing a value of 387 (183 hex) to Point 70 specifies drive parameter b1-04. Reading Point 71 returns the current setting of parameter b1-04 to the controller.

#### ■ Writing to a Drive Parameter

Two points are defined for writing to any drive parameter:

- Point 72 specifies the parameter to be written to
- Point 73 is the entry location of the value to be written to the parameter specified in Point 72

When this point is written to, it will write the value to the drive. An enter or accept command does not need to be sent for the data to be taken by the drive. The behavior of the write is the same as with the HOA keypad. If the drive is running, there are a limited number of drive parameters that can be written to.

Example:

Writing a value of 387 (183 hex) to Point 72 specifies drive parameter b1-04. Writing a value of 1 to Point 73 enables the drive for reverse run.

## E.7 Fault Codes

### ◆ Communications Fault

Table E.5 Drive Faults

Fault	Description	Cause	Corrective Action
FB14	FB14 Communication Error	Connection is broken or master has stopped communicating	Check all connections Verify all APOGEE FLN software configurations

### ◆ Z1000 Bypass Faults–Apogee FLN Configuration

Table E.6 Bypass Faults

Fault Number (Decimal)	Fault Number (Hex)	Fault Name	Fault Number (Decimal)	Fault Number (Hex)	Fault Name
0	0000H	No Fault	42	002AH	UL4 - Undertorq Det 2
1	0001H	PUF - DC Bus Fuse Open	43	002BH	oL7 - HSB Overload
2	0002H	Uv1 - DC Bus Undervolt	59	003BH	SEr - Search Retry Err
3	0003H	Uv2 - CTL PS Undervolt	65	0041H	FbH - PI Fdbk High
4	0004H	Uv3 - MC Answerback	66	0042H	EF1 - Ext Fault S1
5	0005H	SC - Short Circuit	67	0043H	EF2 - Ext Fault S2
6	0006H	GF - Ground Fault	68	0044H	OL5 - Mech Fatigue OL
7	0007H	oC - Over Current	69	0045H	UL5 - Mech Fatigue UL
8	0008H	ov - DC Bus Overvolt	70	0046H	CoF - Current Offset
9	0009H	oH - Heatsnk Overtemp	71	0047H	PE1 - PLC Fault 1
10	000AH	oH1 - Heatsnk MAX Temp	72	0048H	PE2 - PLC Fault 2
11	000BH	oL1 - Motor Overloaded	73	0049H	DWFL - DWEZ Fault
12	000CH	oL2 - Drive Overloaded	74	004AH	DWF1 - DWEZ EEPROM Fault
13	000DH	oL3 - Overtorque Det 1	77	004DH	voF - Vout Det Error
14	000EH	oL4 - Overtorque Det 2	78	004EH	rF - Tr RFerr
15	000FH	rr - DynBrk Transistr	79	004FH	boL - Tr BOLerr
16	0010H	rH - DynBrk Resistor	80	0050H	OH5 - Motor Overtemp
17	0011H	EF3 - Ext Fault S3	90	005AH	UL6 - Underload Det 6
18	0012H	EF4 - Ext Fault S4	91	005BH	DV7 - PlrtyDet Timeout
19	0013H	EF5 - Ext Fault S5	92	005CH	GF1 - GF1 Error
20	0014H	EF6 - Ext Fault S6	131	0083H	CPF02 - Internal A/D Err
21	0015H	EF7 - Ext Fault S7	132	0084H	CPF03 - CPU Serial Err
23	0017H	FAn - Cooling FAN Err	134	0086H	CPF05 - CPU adjust Err
24	0018H	oS - Overspeed Det	135	0087H	CPF06 - EEPROM Error
27	001BH	PF - Input Pha Loss	136	0088H	CPF07 - Term Serial Err
28	001CH	LF - Output Pha Loss	137	0089H	CPF08 - EEPROM Error
29	001DH	oH3 - Motor Overheat 1	138	008AH	CPF09 - EEPROM Error
30	001EH	oPr - Oper Disconnect	140	008CH	CPF11 - RAM-Err
31	001FH	Err - EEPROM R/W Err	141	008DH	CPF12 - ROM-Err
32	0020H	oH4 - Motor Overheat 2	142	008EH	CPF13 - Watchdog Error
33	0021H	CE - Serial Com Err	143	008FH	CPF14 - Ctrl Circuit Err
34	0022H	bUS - Option Com Err	145	0091H	CPF16 - CLK-Err
35	0023H	E-15 - SI-F/G Com Err	146	0092H	CPF17 - Interrupt Err
36	0024H	E-10 - SI-F/G CPU down	147	0093H	CPF18 - Ctrl circuit Err
37	0025H	CF - Control Fault 1	148	0094H	CPF19 - Ctrl circuit Err
39	0027H	EF0 - Opt External Flt	149	0095H	CPF20 - CPU-Err
40	0028H	FbL - Feedback Loss	150	0096H	CPF21 - CPU-Err
41	0029H	UL3 - Undertorq Det 1	151	0097H	CPF22 - Internal A/D Err

Fault Number (Decimal)	Fault Number (Hex)	Fault Name	Fault Number (Decimal)	Fault Number (Hex)	Fault Name
152	0098H	CPF23 - 2 CPU COM Err	1030	0406H	LF3 - Output Pha Loss3
153	0099H	CPF24 - US Signal Error	1031	0407H	FN1 - Cooling FAN Err
154	009AH	CPF25 - No Tmnl card	5001	1389H <1>	FB01 - Safety Open
155	009BH	CPF26 - BB Circuit ERR	5002	138AH <1>	FB02 - BAS Ilock TO
156	009CH	CPF27 - PWM Set Reg ERR	5003	138BH <1>	FB03 - External EFB
157	009DH	CPF28 - PWM Pattern ERR	5004	138CH <1>	FB04 - Smoke Purge Drv
158	009EH	CPF29 - On-Delay ERR	5005	138DH <1>	FB05 - Motor Overload
159	009FH	CPF30 - BB On ERR	5006	138EH <1>	FB06 - Ext Motor1 OL
160	00A0H	CPF31 - ASIC Code ERR	5007	138FH <1>	FB07 - Ext Motor2 OL
161	00A1H	CPF32 - ASIC Startup ERR	5008	1390H <1>	FB08 - PL Brownout
162	00A2H	CPF33 - Watch-dog ERR	5009	1391H <1>	FB09 - PL Blackout
163	00A3H	CPF34 - Power/Clock ERR	5010	1392H <1>	FB10 - No Drive Comms
164	00A4H	CPF35 - Ext A/D Conv ERR	5011	1393H <1>	FB11 - Bypass Bd HW Err
257	0101H	oFA00 - Not supported	5012	1394H <1>	FB12 - Option Bd Comms
258	0102H	oFA01 - Connection error	5013	1395H <1>	FB13 - Loss of Load
259	0103H	oFA02 - DuplicateOptions	5014	1396H <1>	FB14 - Serial Comm Flt
260	0104H	oFA03 - Diagnostic Err	10001	2711H <2>	FB01 - Safety Open
261	0105H	oFA04 - Flash Write Mode	10002	2712H <2>	FB02 - BAS Ilock TO
262	0106H	oFA05 - Opt A/D ERR	10003	2713H <2>	FB03 - External EFB
263	0107H	oFA06 - Opt Comm ERR	10004	2714H <2>	FB04 - Smoke Purge Drv
273	0111H	oFA10 - Opt RAM ERR	10005	2715H <2>	FB05 - Motor Overload
274	0112H	oFA11 - Opt Ope Mode ERR	10006	2716H <2>	FB06 - Ext Motor1 OL
275	0113H	oFA12 - DRV RCV CRC ERR	10007	2717H <2>	FB07 - Ext Motor2 OL
276	0114H	oFA13 - DRV RCV FrameERR	10008	2718H <2>	FB08 - PL Brownout
277	0115H	oFA14 - DRV RCV AbortERR	10009	2719H <2>	FB09 - PL Blackout
278	0116H	oFA15 - Opt RCV CRC ERR	10010	271AH <2>	FB10 - No Drive Comms
279	0117H	oFA16 - Opt RCV FrameERR	10011	271BH <2>	FB11 - Bypass Bd HW Err
280	0118H	oFA17 - Opt RCV AbortERR	10012	271CH <2>	FB12 - Option Bd Comms
305	0131H	oFA30 - COM ID Error	10013	271DH <2>	FB13 - Loss of Load
306	0132H	oFA31 - Type code Error	10014	271EH <2>	FB14 - Serial Comm Flt
307	0133H	oFA32 - SUM Chk Error	10015	271FH <2>	FB15 - Input Phase Loss
308	0134H	oFA33 - OPT R TimeOver	10016	2720H <2>	FB16 - Inp Phs Rotation
309	0135H	oFA34 - MemobusTimeOver	10017	2721H <2>	FB17 - Load Lost
310	0136H	oFA35 - INV R TimeOver 1	10018	2722H	FB18 - K3 Welded <3>
311	0137H	oFA36 - CI Chk Error	10019	2723H	FB19 - Duplicate Input <3>
312	0138H	oFA37 - INV R TimeOver 2	10020	2724H	FB20 - Fire Stat (Safety) <3>
313	0139H	oFA38 - Ctrl Ref Error	10021	2725H	FB21 - Freeze Stat (Safety) <3>
314	013AH	oFA39 - INV R TimeOver 3	10022	2726H	FB22 - Smoke Alarm (Safety) <3>
315	013BH	oFA40 - CtrlResSel 1Err	10023	2727H	FB23 - Over Pressure (Safety) <3>
316	013CH	oFA41 - INV R TimeOver 4	10024	2728H	FB24 - Low Suction (Safety) <3>
317	013DH	oFA42 - CtrlResSel 2Err	10025	2729H	FB25 - Vibration Switch (Safety) <3>
318	013EH	oFA43 - INV R TimeOver 5	10026	272AH	FB26 - Option On Drive (Safety) <3>
1025	0401H	TIM - Time Not Set			
1026	0402H	BAT - Oper Battery Low			
1027	0403H	TDE - Time Data Err			
1028	0404H	TIE - TimeIntervalErr			
1029	0405H	ov2 - DC Bus Overvolt2			

<1> Available in bypass controller software versions VST800297 and earlier. Displayed by P1 Apogee Point LAI 17.

<2> Available in bypass controller software versions VST800298 and later. Displayed by P1 Apogee Point LAI 17.

<3> Available in bypass controller software versions VST800400 and later.



# Appendix: F

## Metasys N2 Network Protocol

---

<b>F.1</b>	<b>N2 SPECIFICATIONS AND CONFIGURATION.....</b>	<b>440</b>
<b>F.2</b>	<b>CONNECTING TO A NETWORK.....</b>	<b>441</b>
<b>F.3</b>	<b>N2 SETUP PARAMETERS.....</b>	<b>443</b>
<b>F.4</b>	<b>BYPASS OPERATIONS BY N2.....</b>	<b>446</b>
<b>F.5</b>	<b>COMMUNICATIONS TIMING.....</b>	<b>450</b>
<b>F.6</b>	<b>METASYS N2 POINT DATABASE.....</b>	<b>451</b>
<b>F.7</b>	<b>MAILBOX FUNCTION.....</b>	<b>454</b>

## F.1 N2 Specifications and Configuration

The bypasses can be monitored and controlled by a controller on a Metasys N2 network (N2) using RS-485 technology. The bypass act as slaves on the N2 network.

Up to 255 bypasses can communicate on a single N2 network. If more bypasses or N2 devices are required, another N2 network is required.

The N2 node address is configurable by a parameter in the bypass. This defines the physical address of the bypass on the N2 network.

Once the addressing is set, a controller can initiate communication to the bypass. The bypass will perform the specified function and then send a response back to the controller.

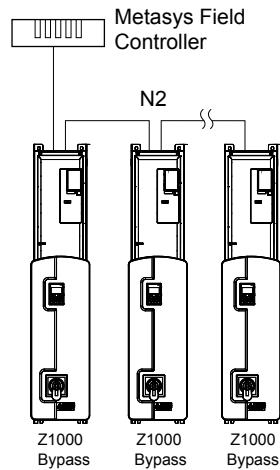

Figure F.1 Connecting Multiple Bypasses to a Metasys N2 Network

N2 specifications appear in the following table:

Item	Specifications
Interface	RS-485
Communication Parameters	Communication Speed: 9600 bps Data Length: 8-bit (fixed) Parity: None Stop Bit: 1-bit (fixed)
Protocol	Metasys N2
Max Number of Drives	255 per N2 Network Segment



## F.2 Connecting to a Network

This section explains how to connect the drive to an N2 network and the network termination required for a connection.

### ◆ Network Cable Connection

Follow the instructions below to connect the bypass to a N2 network.

1. With the power shut off, connect the communications cable to the bypass controller and the master. Use terminal TB3 for N2.

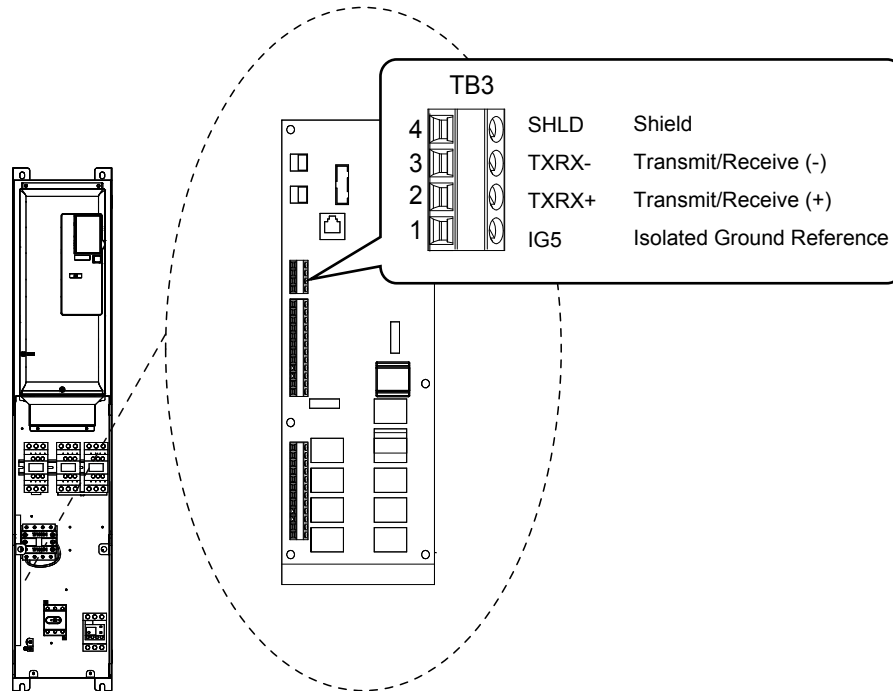

Figure F.2 Serial Communications Cable Connection Terminal (TB3)

**Note:** Separate the communications cables from the main circuit cables and other wiring and power cables. Use shielded cables for the communications cables, and properly shielded clamps to prevent problems caused by electrical interference.

2. Check or set the termination resistor selection at all slaves. Refer to the description in the **Network Termination** section for details on the termination resistor.
3. Switch the power on.
4. Set the parameters needed for serial communications (Z3-01 through Z3-11) using the digital operator.
5. Shut the power off and wait until the display on the digital operator goes out completely.
6. Turn the power back on.
7. The bypass is now ready to begin communicating with the master.

### ◆ Wiring Diagram for Multiple Connections

Figure C.3 explains the wiring diagrams for multiple connections using N2 communication.

#### ■ RS-485 Interface

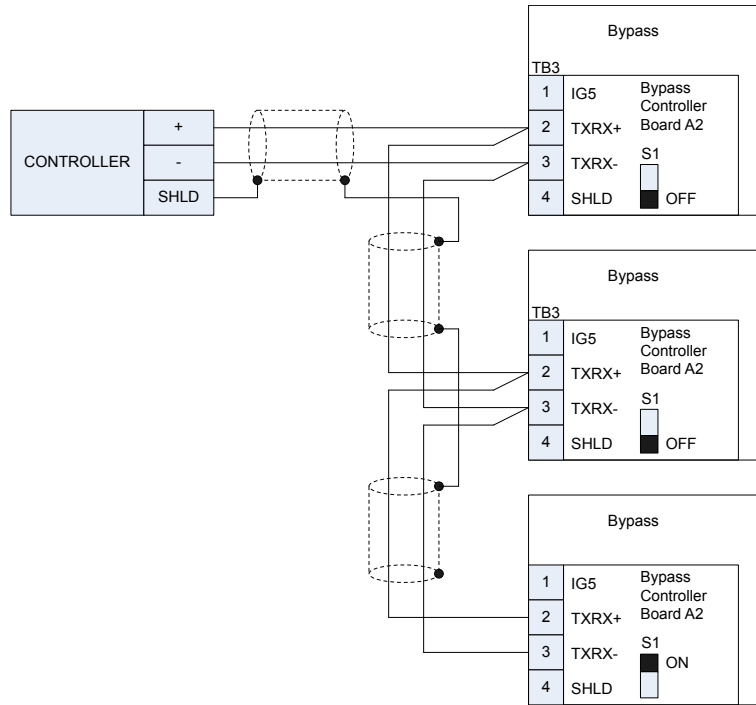

Figure F.3 Connection Diagram for Multiple Connections

**Note:** Turn on DIP switch S1 on the bypass that is located at the end of the network. If S1 is missing, then an external 120 ohm resistor must be placed across terminals TXRX+ and TXRX-. All other slave devices must have this DIP switch set to the OFF position (or if S1 is missing, no external resistor is used).

### ◆ Network Termination

The two ends of the network line must be terminated with a 120 ohm resistor between the TXRX+ and TXRX- signals. The Z1000 Bypass has a built in termination resistor that can be enabled or disabled using DIP switch S1. If a bypass is located at the end of a network line, enable the termination resistor by setting DIP switch S1 to the ON position. Disable the termination resistor on all slaves that are not located at the network line end.

**Note:** Some bypass controllers do not have DIP switch S1. In such cases an external 120 ohm resistor must be placed across the TXRX+ and TXRX- signals if the bypass controller is at the end of a network line.

## F.3 N2 Setup Parameters

### ◆ N2 Serial Communication

This section describes parameters necessary to set up N2 communications.

#### ■ Z3-01: Serial Communications Protocol Select

Selects the communications protocol.

No.	Name	Setting Range	Default
Z3-01	Serial Communications Protocol Selection	0 to 3	0

**Setting 0: MEMOBUS/Modbus**

**Setting 1: N2**

**Setting 2: P1**

**Setting 3: BACnet**

#### ■ Z3-02: Serial Communications Node Address Select

Sets the drive slave address used for communications.

**Note:** Cycle the power after changing this parameter to enable the new setting.

No.	Name	Setting Range	Default
Z3-02	Serial Communications Node Address Select	0 to FFH	1FH

Each slave drive must be assigned a unique slave address for serial communications to work. Slave addresses do not need to be assigned in sequential order, but no two drives may share the same address.

#### ■ Z3-03: Serial Communications Baud Rate Select

Selects the bypass serial communications speed.

Selecting settings 0, 1, or 2 will trigger an oPE29 error when using BACNet communication (Z3-01 = 3) in bypass controller software versions VST800400 and later.

No.	Name	Setting Range	Default
Z3-03	Serial Communications Baud Rate Select	0 to 8	3

**Setting 0: 1200 bps**

**Setting 1: 2400 bps**

**Setting 2: 4800 bps**

**Setting 3: 9600 bps**

**Setting 4: 19200 bps**

**Setting 5: 38400 bps**

**Setting 6: 57600 bps**

**Setting 7: 76800 bps**

**Setting 8: 115200 bps**

#### ■ Z3-04: Serial Communications Parity Select

Sets the parity used for communications.

**Note:** Cycle the power after changing this parameter to enable the new setting.

No.	Name	Setting Range	Default
Z3-04	Serial Communications Parity Select	0 to 2	0

## F.3 N2 Setup Parameters

**Setting 0: No parity**

**Setting 1: Even parity**

**Setting 2: Odd parity**

### ■ Z3-05: Serial Communications Fault Select

Selects the action to take when a serial communications fault is detected. A serial communications fault is detected when after last communicating, no communications occurs within the time set to Z3-06.

No.	Name	Setting Range	Default
Z3-05	Serial Communications Fault Select	0 to 4	1

**Setting 0: Ignore**

**Setting 1: Alarm Only**

**Setting 2: Fault with EF0**

An EF0 fault will be sent to the drive.

**Setting 3: Fault with EF0 and Open Contactors**

An EF0 fault will be sent to the drive and the bypass contactor (K3) will be opened.

**Setting 4: Alarm and run at preset speed set in Z3-10**

Display AL14 alarm on operator.

### ■ Z3-06: Serial Communications Fault Time Select

Sets the time allowed to elapse since receiving serial communications before triggering a communications fault. A value of 0.0 means to never time out.

No.	Name	Setting Range	Default
Z3-06	Serial Communications Fault Detection Time	0.0 to 99.9 s	2.0 s

### ■ Z3-07: Serial Communications Receive to Transmit Wait Time

Sets the time to delay a serial communications response to a serial communications command.

No.	Name	Setting Range	Default
Z3-07	Serial Communications Receive to Transmit Wait Time	0 to 99 ms	5 ms

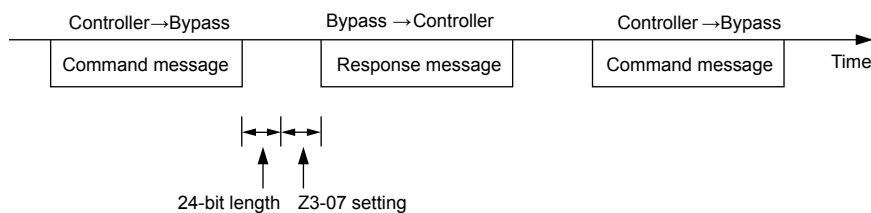

Figure F.4 Serial Communications Receive to Transmit Wait Time Setting

### ■ Z3-10: Cable Loss Pre-set Speed

When a serial communications fault is detected and Z3-05=4, the value here will become the frequency reference.

No.	Name	Setting Range	Default
Z3-10	Cable Loss Pre-set Speed	0.0 to 60.0 Hz	0.0 Hz

### ■ Z3-11: Serial Communication Fault Detection Selection

Enables or disables the serial communications fault detection.

No.	Name	Setting Range	Default
Z3-11	Serial Communication Fault Detection Selection	0 or 1	1

**Setting 0: Disabled**

No communication error detection. Ignore setting in Z3-05.

### Setting 1: Enabled

If the bypass does not receive data from the master for longer than the time set to Z3-06, then a FB14 Serial Communications fault will be triggered and the bypass will operate as determined by parameter Z3-05.

## F.4 Bypass Operations by N2

The drive operations that can be performed by N2 communication depend on drive parameter settings. This section explains the functions that can be used and related parameter settings.

### ◆ Observing the Bypass Operation

A controller can perform the following actions with N2 communications at any time regardless of parameter settings (except for Z3-□□ parameters):

- Observe drive status and drive control terminal status from a controller
- Read and write parameters
- Set and reset faults
- Set multi-function inputs.

**Note:** Input settings from the input terminals S□ and from N2 communications are both linked by a logical OR operation.

### ◆ Controlling the Bypass

Select an external reference and adjust the parameters in [Table C.1](#) accordingly to start and stop the drive or set the frequency reference using N2 communications.

**Table F.1 Setting Parameters for Bypass Control from N2**

Reference Source	Parameter	Name	Required Setting
External Reference 1	Z1-07	Frequency Reference Select	2
	Z1-08	Run Command Select	2

### ■ Z1000 Bypass Functions

Each of the following functions must be enabled during start-up:

#### Start and Stop the Bypass

Set the Run Forward Command (BO 1) to run the in the forward direction. Set the Run Reverse Command (BO 2) to run the in the reverse direction. Run/Stop Monitor (BI 1) shows the current run status. Forward/Reverse Monitor (BI 2) shows the current direction.

**NOTICE:** *Damage to Equipment. Improper motor direction may damage HVAC equipment if parameter b1-04, Reverse Enable, is set to 0 (Enable).*

#### Lock the Z1000 Bypass Panel

This function is not supported in the Z1000 Bypass.

#### Digital Inputs

Multi-Function Input S3 (BO 5) through Multi-Function Input S7 (BO 9) are physical digital inputs on the bypass. They can be set either by external devices, such as limit or pressure switches, or by the network. Their function depends on how the bypass has been programmed. The multi-function input status can be monitored through Multi-Function Input 3 Monitor (BI 15) through Multi-Function Input 7 Monitor (BI 19). The Multi-Function Input # Monitor state is the logical OR of the serial command value (BO 5 through BO 9) and the state of the external connection.

**Note:** The multi-function inputs can be set by both external devices or over the network. Use caution when connecting the multi-function inputs to external devices to ensure correct system operation.

#### Digital Outputs

Multi-Function Output 7 (BI 10) through Multi-Function Output 9 (BI 12) are physical digital outputs on the bypass. Their function depends on how the bypass is programmed. Refer to the Z1000 Bypass Technical Manual section on Multi-Function Outputs (Z2-23 through Z2-25) for detailed information on the use and programming of the multi-function outputs.

#### Loop Gain

PI Proportional Gain (AO 4) and PI Integral Time (AO 5) are the gain and integral time parameters used by the Z1000. The Z1000 PI loop is structured differently than the Metasys loop. Refer to the Z1000 Bypass Technical Manual section on PI for information on Z1000 PI loop functions.

### Reading and Resetting Faults

The Fault Monitor (BI 4) and Drive Ready Monitor (BI 3) show the current status of the bypass. The Fault Code (AI 10) contains the code for the most current fault. The LST Fault Code (AI 19) contains the code for the previous drive fault. *Refer to Fault Trace / History Register Contents on page 448* for descriptions of the fault codes. The drive faults can be reset through the Fault Reset Command (BO 4). The Fault Reset Command is only available when the Run Forward Command and the Run Reverse Command are both OFF.

### ■ Cable Loss Configuration and Behavior

This section describes the configurable cable loss feature of the drive. This feature offers a user maximum flexibility in determining drive response to a loss of communication.

#### Drive Behavior at Loss of Communication

The drive can be configured to respond to an interval without receipt of a message in one of the following methods:

- Continue at last speed
- Continue at last speed with alarm
- Continue at preset speed
- Ramp to Stop with FB14 fault
- Coast to Stop with FB14 fault
- Emergency Stop with FB14 fault

#### Metasys N2 I/O

Three Metasys N2 outputs are used to select the desired behavior:

- AO 21 – Cable Loss Timeout
- AO 22 – Cable Loss Speed
- BO 11 – Communication Fault Enable

Table F.2 Cable Loss Behavior Summary

Behavior	F6-03	Z3-05	Cable Loss Timeout (AO 21)	Cable Loss Speed (AO 22)	Communication Fault Enable (BO 11)
Decelerate to stop (stop time in C1-02) FB14 Fault. <b>Note:</b> In Bypass mode, bypass contactor will open and motor will coast to stop.	0	3	Timeout Interval	X	On
Coast to stop FB14 fault. <b>Note:</b> In Bypass mode, bypass contactor will open and motor will coast to stop.	1	3	Timeout Interval	X	On
Fast stop (stop time in C1-09) FB14 fault. <b>Note:</b> In Bypass mode, bypass contactor will open and motor will coast to stop.	2	3	Timeout Interval	X	On
Continue at last speed	3	0	0	X	X
Continue at last speed with alarm	3	1	Timeout Interval	X	On
Continue at preset speed with alarm	3	4	Timeout Interval	Preset speed	On

- Note:**
1. Communication must first be established and then lost for these features to function as described. If a bypass is powered-up without a cable connected or with the master controller offline, a communications timeout does not occur.
  2. For modes that describe the bypass running after a communications timeout, a run command must have been issued (BO 1 = 'On' or BO 2 = 'On') prior to loss of communications. For safety purposes, the drive will not automatically restart from a stopped condition. If a user requires the drive to restart automatically, additional external wiring is required to accomplish this (consult factory).
  3. Upon expiration of the communications timeout interval, the FAULT LED lights and remains lit until communication is restored.

#### Continue at Last Speed

In this mode, Cable Loss Timeout (AO 21) is set to 0, disabling the cable loss feature. The other two settings Cable Loss Speed (AO 22) and Communication Fault Enable (BO 11) are ignored. If communication is lost, the drive simply maintains its last commanded state. The drive will not display an alarm or fault to indicate it has lost communication. This behavior can also be achieved by setting parameter Z3-05 to "0".

## F.4 Bypass Operations by N2

### Continue at Last Speed with Alarm

For this condition, Communication Fault Enable (BO 11) must be enabled and Cable Loss Speed (AO 22) should be set to a value other than 0. An AL14 Serial Communications Alarm is shown.

### Continue at Preset Speed with Alarm

In this mode, Cable Loss Timeout (AO 21) is set to the desired interval, Cable Loss Speed (AO 22) is set to the desired preset speed and Z3-05 is set to "4". If the time between messages exceeds the timeout interval, the drive speed command (AO 1) is set to the Cable Loss Speed (AO 22) and the drive continues running at this new speed. Communication Fault Enable (BO 11) must be set to 'On'.

### Stop with Fault (FB14)

Communication Fault Enable (BO 11) must be set to 'On'. In this mode, Cable Loss Timeout (AO 21) is set to the desired interval and parameter F6-03 is set to a value of 0,1 or 2. If the time between messages exceeds the timeout interval, the drive will declare an EF0 fault and the drive speed command (AO 1) will be set to 0. The stopping method is determined by the setting of F6-03.

- F6-03 = 0 selects Ramp to Stop. The deceleration time or the slope of the ramp is determined by the setting of drive parameter C1-02
- F6-03 = 1 selects Coast to Stop. The drive does not attempt to control the rate of deceleration.
- F6-03 = 2 selects Emergency or Fast Stop. The deceleration time is determined by the setting of drive parameter C1-09.

## ■ Bypass Fault Numbers

Table F.3 Fault Trace / History Register Contents

Fault Code	Fault Name	Fault Code	Fault Name
0002H	Undervoltage (Uv1)	0037H	Pullout Detection (Sto)
0003H	Control Power Supply Undervoltage (Uv2)	003BH	Too Many Speed Search Restarts (SEr)
0004H	Soft Charge Circuit Fault (Uv3)	0041H	PID Feedback Loss (FbH)
0006H	Ground Fault (GF)	0042H	External Fault 1, Input Terminal S1 (EF1)
0007H	Overcurrent (oC)	0043H	External Fault 2, Input Terminal S2 (EF2)
0008H	Overvoltage (ov)	0046H	Current Offset Fault (CoF)
0009H	Heatsink Overheat (oH)	0047H	PLC Detection Error 1 (PE1)
000AH	Heatsink Overheat (oH1)	0048H	PLC Detection Error 2 (PE2)
000BH	Motor Overload (oL1)	004DH	Output Voltage Detection Fault (voF)
000CH	Drive Overload (oL2)	0052H	Node Setup Fault (nSE)
000DH	Overtorque Detection 1 (oL3)	005AH	Motor Underload Protection (UL6)
0010H	Braking Resistor Overheat (rH)	0083H	A/D Conversion Error (CPF02)
0011H	External Fault at Input Terminal S3 (EF3)	0084H	PWM Data Fault (CPF03)
0012H	External Fault at Input Terminal S4 (EF4)	0087H	EEPROM Memory Data Error (CPF06)
0013H	External Fault at Input Terminal S5 (EF5)	0088H	Terminal Board Connection Error (CPF07)
0014H	External Fault at Input Terminal S6 (EF6)	0089H	EEPROM Serial Communication Fault (CPF08)
0015H	External Fault at Input Terminal S7 (EF7)	008CH	RAM Fault (CPF11)
001BH	Input Phase Loss (PF)	008DH	Flash Memory Circuit Exception (CPF12)
001CH	Output Phase Loss (LF)	008EH	Watchdog Circuit Exception (CPF13)
001DH	Motor Overheat (PTC input) (oH3)	008FH	Control Circuit Fault (CPF14)
001EH	Digital Operator Connection (oPr)	0091H	Clock Fault (CPF16)
001FH	EEPROM Write Error (Err)	0092H	Timing Fault (CPF17)
0020H	Motor Overheat (PTC input) (oH4)	0093H	Control Circuit Fault (CPF18)
0021H	MEMOBUS/Modbus Communication Error (CE)	0094H	Control Circuit Fault (CPF19)
0022H	Option Communication Error (bUS)	0095H	Hardware Fault at Power Up (CPF20)
0027H	Option External Fault (EF0)	0096H	Hardware Fault at Communication Start Up (CPF21)
0028H	PID Feedback Loss (FbL)	0097H	A/D Conversion Fault (CPF22)
0029H	Undertorque Detection 1 (UL3)	0098H	PWM Feedback Fault (CPF23)
002BH	High Slip Braking Overload (oL7)	0099H	Drive Unit Signal Fault (CPF24)
0030H	Hardware Fault (including oFx)	009AH	Terminal Board is Not Properly Connected. (CPF25)
0036H	Output Current Imbalance (LF2)	009BH	ASIC BB Circuit Error (CPF26)



Fault Code	Fault Name
009CH	ASIC PWM Setting Register Error (CPF27)
009DH	ASIC PWM Pattern Error (CPF28)
009EH	ASIC On-delay Error (CPF29)
009FH	ASIC BBON Error (CPF30)
00A0H	ASIC Code Error (CPF31)
00A1H	ASIC Start-up Error (CPF32)
00A2H	Watch-dog Error (CPF33)
00A3H	ASIC Power/Clock Error (CPF34)
00A4H	External A/D Converter Error (CPF35)
00A9H	Control Circuit Error (CPF40)
00AAH	Control Circuit Error (CPF41)
00ABH	Control Circuit Error (CPF42)
00ACH	Control Circuit Error (CPF43)
00ADH	Control Circuit Error (CPF44)
00AEH	Control Circuit Error (CPF45)
0101H	Option Compatibility Error (oFA00)
0102H	Option Not Properly Connected (oFA01)
0106H	A/D Conversion Error (oFA05)
0107H	Option Response Error (oFA06)
0111H	Option RAM Fault (oFA10)
0112H	Option Operation Mode Fault (SLMOD) (oFA11)
0113H	Drive Receive CRC Error (oFA12)
0114H	Drive Receive Frame Error (oFA13)
0115H	Drive Receive Abort Error (oFA14)
0116H	Option Receive CRC Error (oFA15)
0117H	Option Receive Frame Error (oFA16)
0118H	Option Receive Abort Error (oFA17)
0131H	Comm. ID Error (oFA30)
0132H	Model Code Error (oFA31)
0133H	Sumcheck Error (oFA32)
0134H	Comm. Option Timeout Waiting for Response (oFA33)

Fault Code	Fault Name
0135H	MEMOBUS Timeout (oFA34)
0136H	Drive Timeout Waiting for Response (oFA35)
0137H	CI Check Error (oFA36)
0138H	Drive Timeout Waiting for Response (oFA37)
0139H	Control Command Selection Error (oFA38)
013AH	Drive Timeout Waiting for Response (oFA39)
013BH	Control Response Selection 1 Error (oFA40)
013CH	Drive Timeout Waiting for Response (oFA41)
013DH	Control Response Selection 2 Error (oFA42)
013EH	Control Response Selection Error (oFA43)
0401H	Time Not Set (TIM)
0402H	Operator Battery Low (bAT)
0403H	Time Data Error (TdE)
0404H	Time Interval Error (TiE)
0405H	Overvoltage 2 (ov2)
0407H	External Fan Fault (Fn1)
1389H	Safety Open
138AH	BAS InterLock Open
138BH	External Fault (EFB)
138CH	Not Used
138DH	Motor Overload
138EH	Ext Motor1 Overload
138FH	Ext Motor2 Overload
1390H	PL Brownout
1391H	PL Blackout
1392H	No Bypass to Drive Communications
1393H	Bypass Board Hardware Error
1394H	Option Board Communication Fault
1395H	Loss of Load
1396H	Serial Communications Timeout

## F.5 Communications Timing

To prevent a communications overrun in the slave drive, the master should wait a certain time between sending messages to the same drive. In the same way, the slave drive must wait before sending response messages to prevent an overrun in the master. This section explains the message timing.

### ◆ Command Messages from Master to Bypass

The master must wait for a specified time between receiving a response and resending the same type of command to the same slave bypass to prevent overrun and data loss. The minimum wait time depends on the command as shown in [Table F.4](#).

**Table F.4 Minimum Wait Time for Sending Messages**

Command Type	Example	Minimum Wait Time
1	<ul style="list-style-type: none"> <li>Control command (Run, Stop)</li> <li>Set inputs/outputs</li> <li>Read monitors and parameter values</li> </ul>	5 ms </>
2	Write parameters	H5-11 = 0: 50 ms H5-11 = 1: 200 ms </>
3	Save changes using an Enter command	200 ms to 2 s, depending on the number of parameters that were changed </>
4	Enter with storage to drive EEPROM after initialization	5 s

<1> If the bypass receives command type 1 data during the minimum wait time, it will perform the command and then respond. However, if it receives a command type 2 or 3 during that time, either a communication error will result or the command will be ignored.

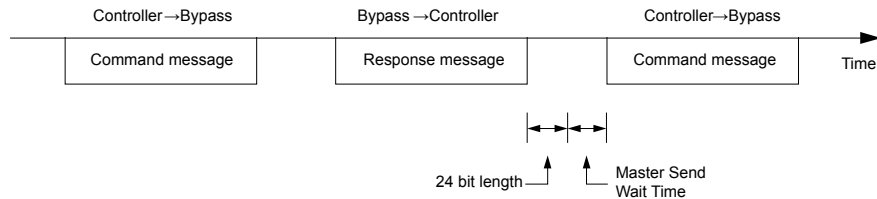
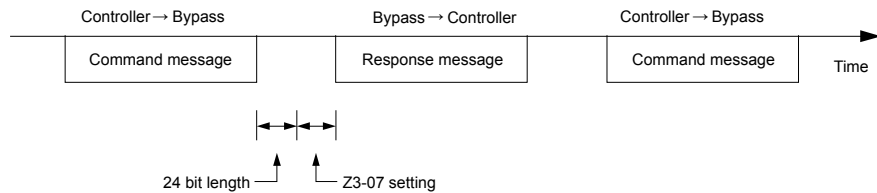

**Figure F.5 Minimum Wait Time for Sending Messages**

Set a timer in the master to check how long it takes for the slave bypass units to respond to the master. If no response is received within a certain amount of time, the master should try resending the message.

### ◆ Response Messages from Bypass to Master

If the bypass receives a command from the master, it will process the data received and wait for the time set in Z3-07 until it responds. Increase Z3-07 if the drive response causes overrun in the master.



**Figure F.6 Minimum Response Wait Time**

## F.6 Metasys N2 Point Database

This section describes the Metasys N2 point database. This database features 100 logical points: 38 Analog Inputs (AI), 32 Analog Outputs (AO), 19 Binary Inputs (BI) and 11 Binary Outputs (BO). These points configure, control, and monitor the operation of the drive.

### ◆ Metasys N2 Analog Input (AI) Summary

Table F.5 Metasys N2 Analog Input Summary (Bypass to Metasys N2)

Object ID	Object Name	Units	Bypass Parameter
AI 1	Speed Reference	0.01 Hz	U1-01
AI 2	Output Speed	0.01 Hz	U1-02
AI 3	Output Current	0.1 A	U1-03/UB-01 in Drive/Bypass Mode
AI 4	kWatt Hour Meter	kWh	U4-10
AI 5	Output Power	0.1 kWh	U1-08
AI 6	Drive Temperature	1 °C	U4-08 Will only report accurately when drive is running.
AI 7	PI Feedback	0.01%	U5-01
AI 8	AC Output Voltage	0.1 Vac	U1-06
AI 9	DC Bus Voltage	1 Vdc	U1-07
AI 10	Fault Code	–	U2-01/UB-09. Reads UB-09 first and if 0 returns U2-01
AI 11	Elapsed Time - Hours	1 hour	U4-01
AI 12	Elapsed Time - 10K Hours	10K hours	U4-01
AI 13	MWatt Hour meter	MWh	U4-11
AI 14	Drive Rated Current	A	n9-01
AI 15	Communication Error Code	–	Not supported. Always returns 0
AI 16	PI Deviation	0.01%	U5-02
AI 17	PI Output Capacity	0.01%	U5-03
AI 18	PI Reference	0.01%	U5-04
AI 19	Last Fault Code	–	U2-02
AI 20	Freq Ref @ Fault	0.01 Hz	U2-03
AI 21	Output Freq @ Fault	0.01 Hz	U2-04
AI 22	Output Current @ Fault	0.1 A	U2-05
AI 23	Out Volt Ref @ Fault	0.1 Vac	U2-07
AI 24	DC Bus Volts @ Fault	1 Vdc	U2-08
AI 25	Output Power @ Fault	0.1 kW	U2-09
AI 26	Input Term Status @ Fault	–	U2-11
AI 27	Output Term Status @ Fault	–	U2-12
AI 28	Operation Status @ Fault	–	U2-13
AI 29	Elapsed Operation Time @ Fault	1 hour	U2-14
AI 30	Most Recent Fault	–	U3-01
AI 31	2nd Most Recent Fault	–	U3-02
AI 32	3rd Most Recent Fault	–	U3-03
AI 33	4th Most Recent Fault	–	U3-04
AI 34	Elapsed Time @ Current Fault	1 hour	U3-11
AI 35	Elapsed Time @ 2nd Fault	1 hour	U3-12
AI 36	Elapsed Time @ 3rd Fault	1 hour	U3-13
AI 37	Elapsed Time @ 4th Fault	1 hour	U3-14
AI 38	Read Parameter Data	–	–

◆ Metasys N2 Analog Output (AO) Summary

Table F.6 Metasys N2 Analog Output Summary (Bypass to Metasys N2)

Object ID	Object Name	Units	Default Value	Bypass Parameter
AO 1	Speed Command	0.01 Hz	–	–
AO 2	Acceleration Time	seconds	30.0	C1-01
AO 3	Deceleration Time	seconds	30.0	C1-02
AO 4	PI Proportional Gain	–	2.00	b5-02
AO 5	PI Integral Time	seconds	5.0	b5-03
AO 6	Stall Prevention Level – Run	%	120	L3-06
AO 7	Stall Prevention Level – Accel	%	120	L3-02
AO 8	Frequency Reference Selection	–	0	Z1-07
AO 9	Run Command Selection	–	1	Z1-08
AO 10	PI Mode Select	–	0	b5-01
AO 11	Frequency Command Upper Limit	% of Max	100.0	d2-01
AO 12	Frequency Command Lower Limit	% of Max	0.0	d2-02
AO 13	Motor Rated Current	A	Motor model dependent	E2-01
AO 14	Jump Frequency 1	0.1 Hz	0.0	d3-01
AO 15	Jump Frequency 2	0.1 Hz	0.0	d3-02
AO 16	Jump Frequency 3	0.1 Hz	0.0	d3-03
AO 17	Jump Frequency Bandwidth	0.1 Hz	1.0	d3-04
AO 18	Number of Auto Restarts	–	0	L5-01
AO 19	Operator Display Mode	–	0	o1-03
AO 20	Power Loss Ride-Thru	seconds	Drive model dependent	L2-02
AO 21	Cable Loss Timeout	seconds	2.0	Z3-06
AO 22	Cable Loss Speed	0.01 Hz	0.00	Z3-10
AO 23	PI Integral Limit	0.1%	100.0	b5-04
AO 24	PI Upper Limit Value	0.1	100.0	b5-06
AO 25	PI Offset Adjustment	0.1	0.0	b5-07
AO 26	PI Primary Delay Time	0.01	0.00	b5-08
AO 27	PI Feedback Reference Missing Detection Select	1	0	b5-12
AO 28	PI Feedback Reference Missing Detection Level	1%	0	b5-13
AO 29	PI Feedback Reference Missing Detection Time	0.1 s	1.0	b5-14
AO 30	Read Parameter Number	–	–	–
AO 31	Write Parameter Number	–	–	–
AO 32	Write Parameter Data	–	–	–

◆ Metasys N2 Binary Input (BI) Summary

Table F.7 Metasys N2 Binary Input Summary (Bypass to Metasys N2)

Object ID	Object Name	Default	Off (0) State	On (1) State
BI 1	Run/Stop Monitor	0	Stopped	Running
BI 2	Forward/Reverse Monitor	0	Forward	Reverse
BI 3	Drive Ready Monitor	0	Not Ready	Ready
BI 4	Fault Monitor	0	Not Faulted	Faulted
BI 5	Zero Speed	0	Not Zero Speed	Zero Speed
BI 6	Speed Agree	0	Not Speed Agree	Speed Agree
BI 7	Minor Fault	0	No Minor Fault	Minor Fault
BI 8	Major Fault	0	No Major Fault	Major Fault
BI 9	Drive Communication Error Monitor	0	No Error	Error

Object ID	Object Name	Default	Off (0) State	On (1) State
BI 10	Multi-Function Output 7 (Z2-23)	0	Off	On
BI 11	Multi-Function Output 8 (Z2-24)	0	Off	On
BI 12	Multi-Function Output 9 (Z2-25)	0	Off	On
BI 13	Safety Interlock Monitor	0	Safety Clear	Safety Set
BI 14	HAND/AUTO Reference Monitor	0	AUTO or OFF	HAND
BI 15	Multi-Function Input 3 Monitor	0	Off	On
BI 16	Multi-Function Input 4 Monitor	0	Off	On
BI 17	Multi-Function Input 5 Monitor	0	Off	On
BI 18	Multi-Function Input 6 Monitor	0	Off	On
BI 19	Multi-Function Input 7 Monitor	0	Off	On

◆ Metasys N2 Binary Output (BO) Summary

Table F.8 Metasys N2 Binary Output Summary (Bypass to Metasys N2)

Object ID	Object Name	Default	Off (0) State	On (1) State
BO 1	Run Forward Command	0	Stop	Forward
BO 2	Run Reverse Command	0	Stop	Reverse
BO 3	External Fault (EFB) Command	0	No Fault	Fault (EFB)
BO 4	Fault Reset Command	0	No Reset	Reset
BO 5 <1>	Multi-Function Input 3 (Z2-03)	0	Off	On
BO 6 <1>	Multi-Function Input 4 (Z2-04)	0	Off	On
BO 7 <1>	Multi-Function Input 5 (Z2-05)	0	Off	On
BO 8 <1>	Multi-Function Input 6 (Z2-06)	0	Off	On
BO 9 <1>	Multi-Function Input 7 (Z2-07)	0	Off	On
BO10	Panel Lock <b>Note:</b> Not supported	0	–	–
BO 11	Communication Fault Enable	0	FB14 Not Activated if Cable Loss Occurs	FB14 Activated if Cable Loss Occurs

<1> Disabled when Z3-12 is set to 0 in bypass controller software versions VST800298 and later.

# F.7 Mailbox Function

---

### ◆ Reading Drive Parameters

Two points are defined for reading drive parameters:

- AO 30 – Specifies the parameter to be read from the bypass.
- AI 38 – Reports the value of the parameter specified in AO 30.

When this point is read, it retrieves data from the parameter and sends it to the controller

Example: Writing a value of 387 (183 hex) to AO 30 specifies drive parameter b1-04. Reading AI 38 returns the current setting of parameter b1-04 to the controller.

---

### ◆ Writing Drive Parameters

Two points are defined for writing to drive parameters:

- AO 31 – Specifies the parameter to be written to
- AO 32 – Entry location of the value to be written to the parameter specified in AO 31. When this point is written to, it will write the value to the drive. An ENTER or ACCEPT command does not need to be sent for the data to be taken by the drive. The behavior of the write is the same as with the digital operator. If the drive is running, there are a limited number of drive parameters that can be written to.

Example: Writing a value of 387 (183 hex) to AO 31 specifies drive parameter b1-04. Writing a value of 1 to AO 32 sets b1-04 to 1 and disables the drive for reverse run.

# Appendix: G

## Standards Compliance

---

This appendix explains the guidelines and criteria for maintaining CE and UL standards.

<b>G.1</b>	<b>SECTION SAFETY.....</b>	<b>456</b>
<b>G.2</b>	<b>EUROPEAN STANDARDS.....</b>	<b>458</b>
<b>G.3</b>	<b>UL/CUL STANDARDS.....</b>	<b>459</b>

## G.1 Section Safety

### DANGER

#### Electrical Shock Hazard

**Before servicing, disconnect all power to the equipment.** The internal capacitor remains charged even after the power supply is turned off. The charge indicator LED will extinguish when the DC bus voltage is below 50 Vdc. To prevent electric shock, wait for at least the time specified on the warning label, once all indicators are OFF, measure for unsafe voltages to confirm the drive is safe prior to servicing.

Failure to comply will result in death or serious injury.

### WARNING

#### Electrical Shock Hazard

**Do not operate equipment with covers removed.**

Failure to comply could result in death or serious injury.

The diagrams in this section may show drives without covers or safety shields to show details. Be sure to reinstall covers or shields before operating the drives and run the drives according to the instructions described in this manual.

**Always ground the motor-side grounding terminal.**

Improper equipment grounding could result in death or serious injury by contacting the motor case.

**Do not touch any terminals before the capacitors have fully discharged.**

Failure to comply could result in death or serious injury.

Before wiring terminals, disconnect all power to the equipment. The internal capacitor remains charged even after the power supply is turned off. After shutting off the power, wait for at least the amount of time specified on the drive before touching any components.

**Do not allow unqualified personnel to perform work on the drive.**

Failure to comply could result in death or serious injury.

Installation, maintenance, inspection, and servicing must be performed only by authorized personnel familiar with installation, adjustment and maintenance of AC drives.

**Do not perform work on the drive while wearing loose clothing, jewelry or without eye protection.**

Failure to comply could result in death or serious injury.

Remove all metal objects such as watches and rings, secure loose clothing, and wear eye protection before beginning work on the drive.

**Do not remove covers or touch circuit boards while the power is on.**

Failure to comply could result in death or serious injury.

#### Fire Hazard

**Tighten all terminal screws to the specified tightening torque.**

Loose electrical connections could result in death or serious injury by fire due to overheating of electrical connections.

**Do not use an improper voltage source.**

Failure to comply could result in death or serious injury by fire.

Verify that the rated voltage of the drive matches the voltage of the incoming power supply before applying power.

**Do not use improper combustible materials.**

Failure to comply could result in death or serious injury by fire.

Attach the drive to metal or other noncombustible material.



**NOTICE**

**Observe proper electrostatic discharge procedures (ESD) when handling the drive and circuit boards.**

Failure to comply may result in ESD damage to the drive circuitry.

**Never connect or disconnect the motor from the drive while the drive is outputting voltage.**

Improper equipment sequencing could result in damage to the drive.

**Do not use unshielded wire for control wiring.**

Failure to comply may cause electrical interference resulting in poor system performance. Use shielded twisted-pair wires and ground the shield to the ground terminal of the drive.

**Do not modify the drive circuitry.**

Failure to comply could result in damage to the drive and will void warranty.

Yaskawa is not responsible for modification of the product made by the user. This product must not be modified.

**Check all the wiring to ensure that all connections are correct after installing the drive and connecting other devices.**

Failure to comply could result in damage to the drive.

**If a fuse is blown or a Ground Fault Circuit Interrupter (GFCI) is tripped, check the wiring and the selection of the peripheral devices.**

Contact your supplier if the cause cannot be identified after checking the above.

**Do not restart the drive immediately operate the peripheral devices if a fuse is blown or a GFCI is tripped.**

Check the wiring and the selection of peripheral devices to identify the cause. Contact your supplier before restarting the drive or the peripheral devices if the cause cannot be identified.

# G.2 European Standards



Figure G.1 CE Mark

The CE mark indicates compliance with European safety and environmental regulations. It is required for engaging in business and commerce in Europe.

European standards include the Machinery Directive for machine manufacturers, the Low Voltage Directive for electronics manufacturers, and the EMC guidelines for controlling noise.

This drive displays the CE mark based on the EMC guidelines and the Low Voltage Directive.

- **Low Voltage Directive:** 2006/95/EC
- **EMC Guidelines:** 2004/108/EC

Devices used in combination with this drive must also be CE certified and display the CE mark. When using drives displaying the CE mark in combination with other devices, it is ultimately the responsibility of the user to ensure compliance with CE standards. After setting up the device, verify that conditions meet European standards.

---

### ◆ CE Low Voltage Directive Compliance

This drive has been tested according to European standard IEC/EN 61800-5-1:2007, and it fully complies with the Low Voltage Directive.

To comply with the Low Voltage Directive, be sure to meet the following conditions when combining this drive with other devices:

#### ■ Area of Use

Do not use drives in areas with pollution higher than degree 2 and overvoltage category 3 in accordance with IEC/EN 664.

#### ■ Installing Fuses on the Input Side

Always install input fuses.

**WARNING! Fire Hazard.** Branch Circuit protection is required to be installed according to applicable local codes and the requirements listed on the Z1000 Bypass nameplate. Failure to comply could result in fire and damage to the bypass and drive or injury to personnel. The Z1000 Bypass is suitable for use on a circuit capable of delivering not more than 100,000 RMS symmetrical amperes, 208 Vac and 480 Vac with the circuit breaker option or when protected by class J or class L fuses as specified on the Z1000 Bypass nameplate. Consult factory with questions.

#### ■ Grounding

The drive is designed to be used in T-N (grounded neutral point) networks. If installing the drive in other types of grounded systems, contact your Yaskawa representative for instructions.

---

### ◆ EMC Guidelines Compliance

This drive is tested according to European standards IEC/EN 61800-3: 2004.

#### ■ EMC Filter Installation

Verify the following installation conditions to ensure that other devices and machinery used with this drive comply with EMC guidelines.

1. Move the screws to the ON position to enable the internal EMC filter.
2. Use braided shield cable for the drive and motor wiring, or run the wiring through a metal conduit.
3. Keep wiring as short as possible. Ground the shield on both the drive side and the motor side.

Please consult Yaskawa for EMC filter installation.

## G.3 UL/cUL Standards

### ◆ UL Standards Compliance

The UL/cUL mark applies to products in the United States and Canada. It indicates that UL has performed product testing and evaluation, and determined that their stringent standards for product safety have been met. For a product to receive UL certification, all components inside that product must also receive UL certification.



Figure G.2 UL/cUL Mark

The Z1000 Bypass is tested in accordance with UL standard UL508A, and the drive is tested in accordance with UL standard UL508C; both comply with UL requirements. The conditions described below must be met to maintain compliance when using this drive in combination with other equipment:

### ■ Installation Area

Do not install the drive to an area greater than pollution degree 2 (UL standard).

**This Page Intentionally Blank**

# Appendix: H

## Quick Reference Sheet

---

This section provides tables to keep record of the Bypass specifications, motor specifications, and parameter settings. Fill in the table data after commissioning the application and have them ready when contacting Yaskawa for technical assistance.

<b>H.1</b>	<b>Z1000 BYPASS AND MOTOR SPECIFICATIONS.....</b>	<b>462</b>
<b>H.2</b>	<b>BASIC PARAMETER SETTINGS.....</b>	<b>463</b>
<b>H.3</b>	<b>USER SETTING TABLE.....</b>	<b>465</b>

# H.1 Z1000 Bypass and Motor Specifications

## ◆ Z1000 Bypass Specifications

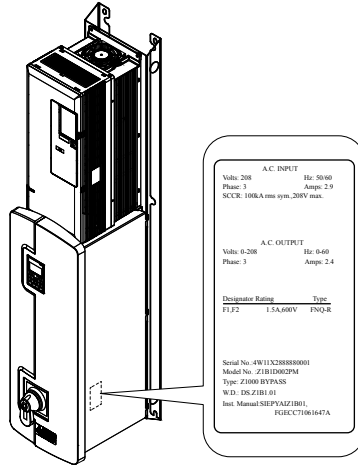

Items	Description
Z1000 Bypass Model	Z1B1
Z1000 Bypass Serial Number	
Z1000 Bypass Software Version	
Options used	
Date of Usage	

## ◆ Motor Specifications

### ■ Induction Motor

Items	Description	Items	Description
Manufacturer		Motor Rated Current (T1-04)	A
Model		Motor Base Frequency (T1-05)	Hz
Motor Rated Power (T1-02)	HP	Number of Motor Poles (T1-06)	
Motor Rated Voltage (T1-03)	V	Motor Base Speed (T1-07)	r/min

**Note:** These values must be entered as part of the Auto-Tuning process.

## H.2 Basic Parameter Settings

Use the following tables to keep records of important parameters. Have this data available when contacting Yaskawa technical support.

### ◆ Quick Setting Parameters

Parameter Name	Setting Value	Memo
Application Preset <1>	A1-06 =	
Input Voltage Setting	E1-01 =	
Maximum Voltage	E1-05 =	
Motor Rated FLA	E2-01 =	
Speed Reference Select	Z1-07 =	
Run Command Select	Z1-08 =	
HAND Mode Drive Speed Reference	Z1-09 =	
Set Time	Z1-37 =	
Serial Protocol	Z3-01 =	
Node Address	Z3-02 =	
Baud Rate	Z3-03 =	
Parity	Z3-04 =	
Fault Select	Z3-05 =	
Fault Time	Z3-06 =	
Rx to Tx Wait	Z3-07 =	
BAC Dev ID0	Z3-08 =	
BAC Dev ID1	Z3-09 =	

<1> Available in Bypass Quick Setting menu for bypass controller software versions VST800299 and earlier.

### ◆ Motor Setup

Motor Type	Item	Setting Value	Memo
Induction	Motor Rated Current	E2-01 =	
	Motor No-Load Current	E2-03 =	

### ◆ Multi-Function Digital Inputs

Terminal	Input Used	Setting Value and Function Name	Memo
TB2-1		Z2-01 =	
TB2-2		Z2-02 =	
TB2-3		Z2-03 =	
TB2-4		Z2-04 =	
TB2-5		Z2-05 =	
TB2-6		Z2-06 =	
TB2-7		Z2-07 =	
TB2-8		Z2-08 =	

## H.2 Basic Parameter Settings

---

### ◆ Analog Inputs

Terminal	Input Used	Setting Value and Function Name	Memo
A1		H3-02 =	
A2		H3-10 =	

### ◆ Multi-Function Digital Outputs

Name	Terminal	Output Used	Setting Value and Function Name	Memo
DO-7	TB1-1, 2, 3		Z2-23 =	
DO-8	TB1-4, 5, 6		Z2-24 =	
DO-9	TB1-7, 8, 9		Z2-25 =	
DO-10	TB1-10, 11, 12		Z2-26 =	

### ◆ Monitor Outputs

Terminal	Output Used	Setting Value and Function Name	Memo
FM		H4-01 =	
AM		H4-04 =	



## H.3 User Setting Table

Use the Verify Menu to see which parameters have been changed from their original default settings

RUN below the parameter number indicates that the parameter setting can be changed during run.

Parameter names in **bold face type** are included in the Quick Setting Group of parameters.

No.	Name	User Setting	No.	Name	User Setting
A1-06	<b>Application Preset</b>		b5-11	PI Output Reverse Selection	
b1-03	Stopping Method Selection		b5-12	PI Feedback Loss Detection Selection	
b1-04	Reverse Operation Selection		b5-13	PI Feedback Loss Detection Level	
b2-03	DC Injection Braking Time at Start		b5-14	PI Feedback Loss Detection Time	
b2-04	DC Injection Braking Time at Stop		b5-15	PI Sleep Function Start Level	
b3-01	Speed Search Selection at Start		b5-16	PI Sleep Delay Time	
b3-02	Speed Search Deactivation Current		b5-17	PI Accel/Decel Time	
b3-03	Speed Search Deceleration Time		b5-18	PI Setpoint Selection	
b3-04	V/f Gain during Speed Search		b5-19	PI Setpoint Value	
b3-05	Speed Search Delay Time		b5-20	PI Setpoint Scaling	
b3-06	Output Current 1 during Speed Search		b5-34	<span style="border: 1px solid black; padding: 0 2px;">RUN</span> PI Output Lower Limit	
b3-07	Output Current 2 during Speed Search (Speed Estimation Type)		b5-35	<span style="border: 1px solid black; padding: 0 2px;">RUN</span> PI Input Limit	
b3-08	Current Control Gain during Speed Search (Speed Estimation Type)		b5-36	PI Feedback High Detection Level	
b3-09	Current Control Integral Time during Speed Search (Speed Estimation Type)		b5-37	PI Feedback High Detection Time	
b3-10	Speed Search Detection Compensation Gain		b5-38	PI Setpoint User Display	
b3-11	Speed Search Method Switching Level (Speed Estimation Type)		b5-39	PI Setpoint Display Digits	
b3-12	Minimum Current Detection Level during Speed Search		b5-40	Frequency Reference Monitor Content during PI	
b3-14	Bi-Directional Speed Search Selection		b5-46	PI Setpoint Monitor Unit Selection	
b3-17	Speed Search Restart Current Level		b5-47	Reverse Operation Selection 2 by PI Output	
b3-18	Speed Search Restart Detection Time		C1-01	<span style="border: 1px solid black; padding: 0 2px;">RUN</span> Acceleration Time 1	
b3-19	Number of Speed Search Restarts		C1-02	<span style="border: 1px solid black; padding: 0 2px;">RUN</span> Deceleration Time 1	
b3-24	Speed Search Method Selection		C1-09	Fast-Stop Time	
b3-25	Speed Search Wait Time		C2-01	S-Curve Characteristic at Accel Start	
b3-27	Start Speed Search Select		C2-02	S-Curve Characteristic at Accel End	
b5-01	PI Function Setting		C4-01	<span style="border: 1px solid black; padding: 0 2px;">RUN</span> Torque Compensation Gain	
b5-02	<span style="border: 1px solid black; padding: 0 2px;">RUN</span> Proportional Gain Setting (P)		C6-02	Carrier Frequency Selection	
b5-03	<span style="border: 1px solid black; padding: 0 2px;">RUN</span> Integral Time Setting (I)		C6-05	Carrier Frequency Proportional Gain	
b5-04	<span style="border: 1px solid black; padding: 0 2px;">RUN</span> Integral Limit Setting		d1-01	<span style="border: 1px solid black; padding: 0 2px;">RUN</span> Frequency Reference 1	
b5-06	<span style="border: 1px solid black; padding: 0 2px;">RUN</span> PI Output Limit		d1-02	<span style="border: 1px solid black; padding: 0 2px;">RUN</span> Frequency Reference 2	
b5-07	<span style="border: 1px solid black; padding: 0 2px;">RUN</span> PI Offset Adjustment		d1-03	<span style="border: 1px solid black; padding: 0 2px;">RUN</span> Frequency Reference 3	
b5-08	<span style="border: 1px solid black; padding: 0 2px;">RUN</span> PI Primary Delay Time Constant		d1-04	<span style="border: 1px solid black; padding: 0 2px;">RUN</span> Frequency Reference 4	
b5-09	PI Output Level Selection		d2-02	Frequency Reference Lower Limit	
b5-10	PI Output Gain Setting		d2-03	Master Speed Reference Lower Limit	

### H.3 User Setting Table

No.	Name	User Setting	No.	Name	User Setting
d3-01	Jump Frequency 1		L2-03	Momentary Power Loss Minimum Baseblock Time	
d3-02	Jump Frequency 2		L2-05	Undervoltage Detection Level (Uv1)	
d3-03	Jump Frequency 3		L3-02	Stall Prevention Level during Acceleration	
d3-04	Jump Frequency Width		L3-03	Stall Prevention Limit during Acceleration	
E1-01	<b>Input Voltage Setting</b>		L3-04	Stall Prevention Selection during Deceleration	
E1-03	V/f Pattern Selection		L3-06	Stall Prevention Level during Run	
E1-04	Maximum Output Frequency		L3-11	Overvoltage Suppression Function Selection	
E1-05	<b>Maximum Voltage</b>		L3-25	Load Inertia Ratio	
E2-01	<b>Motor Rated Current</b>		L5-01	Number of Auto Restart Attempts	
E2-03	Motor No-Load Current		L5-02	Auto Restart Fault Output Operation Selection	
H1-03	Multi-Function Digital Input Terminal S3 Function Selection		L5-03	Time to Continue Making Fault Restarts	
H1-04	Multi-Function Digital Input Terminal S4 Function Selection		L5-04	Fault Reset Interval Time	
H1-05	Multi-Function Digital Input Terminal S5 Function Selection		L5-05	Fault Reset Operation Selection	
H1-06	Multi-Function Digital Input Terminal S6 Function Selection		L6-01	Torque Detection Selection 1	
H1-07	Multi-Function Digital Input Terminal S7 Function Selection		L6-02	Torque Detection Level 1	
H2-01	Multi-Function Contact Output (Terminal M1-M2)		L6-03	Torque Detection Time 1	
H2-02	Multi-Function Contact Output 2 (Terminal M3-M4)		L6-13	Motor Underload Protection Selection	
H2-03	Multi-Function Contact Output 3 (Terminal M5-M6)		L6-14	Motor Underload Protection Level at Minimum Frequency	
H3-01	Terminal A1 Signal Level Selection		L8-02	Overheat Alarm Level	
H3-02	Terminal A1 Function Selection		L8-05	Input Phase Loss Protection Selection	
H3-03	Terminal A1 Gain Setting	<input type="checkbox"/> RUN	L8-06	Input Phase Loss Detection Level	
H3-04	Terminal A1 Bias Setting	<input type="checkbox"/> RUN	L8-07	Output Phase Loss Protection	
H3-09	Terminal A2 Signal Level Selection		L8-09	Output Ground Fault Detection Selection	
H3-10	Terminal A2 Function Selection		L8-38	Carrier Frequency Reduction Selection	
H3-11	Terminal A2 Gain Setting	<input type="checkbox"/> RUN	n1-01	Hunting Prevention Selection	
H3-12	Terminal A2 Bias Setting	<input type="checkbox"/> RUN	n1-02	Hunting Prevention Gain Setting	
H3-13	Analog Input Filter Time Constant		n3-04	High-Slip Braking Overload Time	
H3-14	Analog Input Terminal Enable Selection		n3-13	Overexcitation Deceleration Gain	
H3-16	Terminal A1 Offset		o1-01	Drive Mode Unit Monitor Selection </>	
H3-17	Terminal A2 Offset		o1-02	User Monitor Selection after Power Up </>	
H4-01	Multi-Function Analog Output Terminal FM Monitor Selection		o1-03	Digital Operator Display Selection	
H4-02	Multi-Function Analog Output Terminal FM Gain	<input type="checkbox"/> RUN	o1-09	Frequency Reference Display Units	
H4-03	Multi-Function Analog Output Terminal FM Bias	<input type="checkbox"/> RUN	o1-10	User-Set Display Units Maximum Value	
H4-04	Multi-Function Analog Output Terminal AM Monitor Selection		o1-11	User-Set Display Units Decimal Display	
L1-01	Motor Overload Protection Selection		o2-04	Drive Model Selection	
L1-02	Motor Overload Protection Time		o4-03	Cooling Fan Maintenance Operation Time Setting	
L2-01	Momentary Power Loss Operation Selection		o4-11	UB-9 to UB-16 Initialization	
			S1-01	Stillness Control Selection	
			S1-02	Voltage Reduction Rate	
			S1-03	Voltage Restoration Level	
			S1-04	Voltage Restoration Complete Level	
			S1-05	Voltage Restoration Sensitivity Time Constant	
			S1-06	Voltage Restoration Time Constant at Impact	
			S2-01	Sequence Timer 1 Start Time	<input type="checkbox"/> RUN
			S2-02	Sequence Timer 1 Stop Time	<input type="checkbox"/> RUN

No.	Name	User Setting
S2-03 <input type="checkbox"/> RUN	Sequence Timer 1 Day Selection	
S2-04	Sequence Timer 1 Selection	
S2-05	Sequence Timer 1 Reference Source	
S2-06 <input type="checkbox"/> RUN	Sequence Timer 2 Start Time	
S2-07 <input type="checkbox"/> RUN	Sequence Timer 2 Day Selection	
S2-08 <input type="checkbox"/> RUN	Sequence Timer 2 Day Selection	
S2-09	Sequence Timer 2 Selection	
S2-10	Sequence Timer 2 Reference Source	
S2-11 <input type="checkbox"/> RUN	Sequence Timer 3 Start Time	
S2-12 <input type="checkbox"/> RUN	Sequence Timer 3 Stop Time	
S2-13 <input type="checkbox"/> RUN	Sequence Timer 3 Day Selection	
S2-14	Sequence Timer 3 Selection	
S2-15	Sequence Timer 3 Reference Source	
S2-16 <input type="checkbox"/> RUN	Sequence Timer 4 Start Time	
S2-17 <input type="checkbox"/> RUN	Sequence Timer 4 Stop Time	
S2-18 <input type="checkbox"/> RUN	Sequence Timer 4 Day Selection	
S2-19	Sequence Timer 4 Selection	
S2-20	Sequence Timer 4 Reference Source	
T1-00	Motor 1/Motor 2 Selection	
T1-01	Auto-Tuning Mode Selection	
T1-02	Motor Rated Power	
T1-03	Motor Rated Voltage	
T1-04	Motor Rated Current	
T1-05	Motor Base Frequency	
T1-06	Number of Motor Poles	
T1-07	Motor Base Speed	
T1-11	Motor Iron Loss	
Z1-01 <input type="checkbox"/> RUN	Initialize	
Z1-02 <input type="checkbox"/> RUN	Password	
Z1-03 <input type="checkbox"/> RUN	Password Change	
Z1-05 <input type="checkbox"/> RUN	Auto Transfer to Bypass Upon Drive Fault	
Z1-06 <input type="checkbox"/> RUN	Power-Up Mode	

No.	Name	User Setting
Z1-07 <input type="checkbox"/> RUN	<b>Speed Reference Select</b>	
Z1-08 <input type="checkbox"/> RUN	<b>Run Command Select</b>	
Z1-09 <input type="checkbox"/> RUN	<b>HAND Mode Drive Speed Reference</b>	
Z1-10 <input type="checkbox"/> RUN	Smoke Purge Preset Frequency Reference	
Z1-11 <input type="checkbox"/> RUN	2-Motor AND/OR Function Select	
Z1-12 <input type="checkbox"/> RUN	Run Delay Time	
Z1-13 <input type="checkbox"/> RUN	Pre-Interlock Run Select	
Z1-14 <input type="checkbox"/> RUN	Run Delay Frequency Reference	
Z1-15 <input type="checkbox"/> RUN	Interlock Wait Time	
Z1-16	Energy Savings Mode Enable	
Z1-17 <input type="checkbox"/> RUN	Energy Savings Mode Frequency	
Z1-18 <input type="checkbox"/> RUN	Energy Savings Mode Output Current Level	
Z1-19 <input type="checkbox"/> RUN	Energy Savings Mode Frequency Reference Deadband	
Z1-20 <input type="checkbox"/> RUN	Energy Savings Mode Output Frequency Deadband	
Z1-21 <input type="checkbox"/> RUN	Energy Savings Mode Output Current Deadband	
Z1-22 <input type="checkbox"/> RUN	Energy Savings Mode Time	
Z1-23 <input type="checkbox"/> RUN	Energy Savings Mode Frequency Reference Increase	
Z1-24 <input type="checkbox"/> RUN	Contactors Open Delay Time	
Z1-25 <input type="checkbox"/> RUN	Contactors Close Delay Time	
Z1-27 <input type="checkbox"/> RUN	Phase Loss Brownout Voltage Level	
Z1-28 <input type="checkbox"/> RUN	Phase Loss Brownout Detection Time	
Z1-29 <input type="checkbox"/> RUN	Phase Loss Blackout Voltage Level	
Z1-30 <input type="checkbox"/> RUN	EF0 Fault Delay Time	
Z1-31 <input type="checkbox"/> RUN	Loss of Load Detection Enable	

### H.3 User Setting Table

No.	Name	User Setting	No.	Name	User Setting
Z1-32 RUN	Loss of Load Drive Frequency		Z2-12 RUN	Digital Input 4 Invert Select	
Z1-33 RUN	Loss of Load Drive Output Current		Z2-13 RUN	Digital Input 5 Invert Select	
Z1-34 RUN	Loss of Load Drive Time		Z2-14 RUN	Digital Input 6 Invert Select	
Z1-35 RUN	Loss of Load Bypass Output Current		Z2-15 RUN	Digital Input 7 Invert Select	
Z1-36 RUN	Loss of Load Bypass Time		Z2-16 RUN	Digital Input 8 Invert Select	
Z1-37 RUN	<b>Set Time</b>		Z2-23 RUN	Digital Output 7 Function Select	
Z1-38 RUN	HOA Source Select		Z2-24 RUN	Digital Output 8 Function Select	
Z1-39 RUN	Drive/Bypass Source Select		Z2-25 RUN	Digital Output 9 Function Select	
Z1-41	HAND Speed Reference Selection		Z2-26 RUN	Digital Output 10 Function Select	
Z1-50	Bypass Unbalance Current Detection Level		Z2-31	Safety Open Message Selection <>	
Z1-51	Bypass Unbalance Trip Time Detection Level		Z3-01 RUN	<b>Serial Communications Protocol Select</b>	
Z1-52	Bypass Phase Rotation		Z3-02 RUN	<b>Serial Communications Node Address Select</b>	
Z1-53	Load Verification Fault Select <>		Z3-03 RUN	<b>Serial Communications Baud Rate Select</b>	
Z1-54	LCD Contrast Control <>		Z3-04 RUN	<b>Serial Communications Parity Select</b>	
Z1-55	Welded K3 Contactor Fault Select <>		Z3-05 RUN	<b>Serial Communications Fault Select</b>	
Z1-60	Black Out Selection <>		Z3-06 RUN	<b>Serial Communications Fault Time Select</b>	
Z1-61	Restart Delay <>		Z3-07 RUN	<b>Serial Communications Receive to Transmit Wait Time &lt;&gt;</b>	
Z2-01 RUN	Digital Input 1 Function Select		Z3-08 RUN	<b>BACnet Device Object Identifier 0 &lt;&gt;</b>	
Z2-02 RUN	Digital Input 2 Function Select		Z3-09 RUN	<b>BACnet Device Object Identifier 1 &lt;&gt;</b>	
Z2-03 RUN	Digital Input 3 Function Select		Z3-12	Network Digital Input Selection	
Z2-04 RUN	Digital Input 4 Function Select		Z3-13	BACNet Command Register Retention <>	
Z2-05 RUN	Digital Input 5 Function Select		Z4-01 RUN	IP Address 1	
Z2-06 RUN	Digital Input 6 Function Select		Z4-02 RUN	IP Address 2	
Z2-07 RUN	Digital Input 7 Function Select		Z4-03 RUN	IP Address 3	
Z2-08 RUN	Digital Input 8 Function Select				
Z2-09 RUN	Digital Input 1 Invert Select				
Z2-10 RUN	Digital Input 2 Invert Select				
Z2-11 RUN	Digital Input 3 Invert Select				

No.	Name	User Setting	No.	Name	User Setting
Z4-04 RUN	IP Address 4		Z4-14 RUN	Duplex Mode Setting	
Z4-05 RUN	Subnet Mask 1		Z4-15 RUN	Speed Mode Setting	
Z4-06 RUN	Subnet Mask 2		Z4-16 RUN	Timeout	
Z4-07 RUN	Subnet Mask 3		Z4-17 RUN	Speed Scaling	
Z4-08 RUN	Subnet Mask 4		Z4-18 RUN	Current Scaling	
Z4-09 RUN	Gateway Address 1		Z4-19 RUN	Torque Scaling	
Z4-10 RUN	Gateway Address 2		Z4-20 RUN	Power Scaling	
Z4-11 RUN	Gateway Address 3		Z4-21 RUN	Voltage Scaling	
Z4-12 RUN	Gateway Address 4		Z4-22 RUN	Time Scaling	
Z4-13 RUN	Address Startup Mode				

- <1> Available in bypass controller software versions VST800401 and later
- <2> This parameter will only appear when Modbus N2 or P1 is selected. (Z3-01= 0, 1, or 2)
- <3> This parameter will only appear when Bacnet is selected. (Z3-01= 3)
- <4> Available in bypass controller software versions VST800400 and later.
- <5> Available in bypass controller software versions VST800299 and earlier.

**This Page Intentionally Blank**

# Index

+		AUTO LED and HAND LED Indications	95
+V	71	AUTO Light	92
<b>Numerics</b>		Auto Restart Fault Output Operation Selection	174
5th Most Recent Fault	358	Auto Restart Operation Selection	345
<b>A</b>		Auto-Tuning	111, 114
A/D Conversion Error	230	Auto-Tuning Codes	255
A1	71	Auto-Tuning Errors	227
A1-04	259	Auto-Tuning Fault Codes	112
A1-05	259	Auto-Tuning Fault Detection	255
A2	71	Auto-Tuning Fault Solutions	255
AC	71	Auto-Tuning for Induction Motors	111
Accel/Decel Time	224, 320	Auto-Tuning Input Data	111, 112
Acceleration Error	256	Auto-Tuning Interruption Codes	112
Acceleration Time	139	Auto-Tuning Mode Selection	114, 352
Adjusted Slip Calculation Error	255	<b>B</b>	
AL02	245	BACnet Configuration	376
AL03	245	BACnet Objects Supported	383
AL04	245	BACnet Serial Communication	380
AL09	245	BACnet Setup Parameters	380
AL13	245	BACnet Specifications	377
AL14	245	Baseblock	246
AL16	246	Basic Auto-Tuning Preparations	111
Alarm Causes and Solutions	245	BAS Interlock Open	245
Alarm Outputs for Maintenance Monitors	288	bAT	229
Alarm Register 007FH Contents	420	Baud Rate Setting Error	254
Alarms and Errors	225	bb	246
Allowable Frequency Fluctuation	316, 317, 318, 319	Bi-Directional Speed Search Selection	126
Allowable Voltage Fluctuation	316, 317, 318, 319	Binary Input Objects	386
ALM LED Light	92	Binary Output Objects	386
Altitude	40, 320	Binary Value Objects	387
Ambient Temperature	40, 320	Black Out Selection	210
Analog Filter Time Constant	224	Braking Torque	320
Analog Input Filter Time Constant	162	Broadcast Messages	418
Analog Input Objects	384	bUS	229, 246
Analog Input Terminal Enable Selection	163	Bypass Communication Options	270
Analog Output Objects	384	Bypass Controller Active Faults Register 1	354
Analog Value Objects	384	Bypass Controller Active Faults Register 2	355
Apogee FLN Cable Loss Behavior	433	Bypass Controller Status Register 1	354
APOGEE FLN Cable Specifications	426	Bypass Controller Status Register 2	354
APOGEE FLN Communications	424	Bypass Control System	196
APOGEE FLN Point Number Summary	429	Bypass Digital Input States	354
Application Presets	108	Bypass Digital Input Terminal Settings	210, 213
Application Selection	108	Bypass Digital Output States	354
Area of Use	320	Bypass Model Enclosure Dimensions	44, 46, 48
AUTO Key	92	Bypass Nameplate	29
		Bypass Operations by BACnet	382

Bypass Operations by MEMOBUS/Modbus .....	402	Cooling Tower Fan with PI Control Application .....	109
Bypass Operations by N2 .....	446	CPF00 or CPF01 .....	230
Bypass Parameters .....	196	CPF02 .....	230
Bypass Phase Rotation .....	208	CPF03 .....	230
Bypass Unbalanced Current Detection Level .....	207	CPF06 .....	230
Bypass Unbalance Trip Time Detection Level .....	208	CPF07 .....	230
<b>C</b>		CPF08 .....	230
C2-01 and C2-02 .....	224	CPF20 .....	231
C4-01 .....	224	CPF21 .....	231
C4-02 .....	224	CPF22 .....	231
C6-02 .....	224	CPF23 .....	231
Cable Length Between Bypass and Motor .....	64	CPF24 .....	231
Cable Loss Behavior Summary .....	433	CRC-16 .....	404
Cable Loss Pre-set Speed .....	444	CRC-16 Checksum Calculation Example .....	405
Cable Specifications for APOGEE FLN .....	426	CrST .....	247
CALL .....	246	Cumulative Operation Time .....	360
Cannot Change Parameter Settings .....	259	Cumulative Operation Time at 5th Most Recent Fault .....	358
Cannot Reset .....	247	Cumulative Operation Time at Most Recent Fault .....	358
Capacitor Maintenance .....	360	Cumulative Operation Time at Previous Fault .....	357
Capacitor Maintenance Time .....	248	Current Alarm .....	248
Carrier Frequency .....	316, 317, 318, 319	Current Control Gain during Speed Search (Speed Estimation Type) .....	126
Carrier Frequency Derating .....	324	Current Control Integral Time during Speed Search (Speed Estimation Type) .....	126
Carrier Frequency Proportional Gain .....	141	Current Detection Error .....	256
Carrier Frequency Reduction .....	346	Current Detection Speed Search .....	122
Carrier Frequency Reduction Selection .....	180	Current Fault .....	355, 357, 362
Carrier Frequency Selection .....	64, 224	Current Fault Hour Minute .....	355
Carrier Frequency Setting Error .....	253	Current Fault Month Day .....	355
CE .....	229, 247	Current Fault Year .....	355
CE Low Voltage Directive Compliance .....	458	Current Offset Fault .....	229
CE mark .....	458	Customer Safety .....	250
Changing Parameter Settings or Values .....	99	Cyclic Redundancy Check .....	404
Coast to stop .....	119	<b>D</b>	
Coast with Timer .....	120	d3-01 through d3-04 .....	224
CoF .....	229	Daily Inspection .....	284
Command Messages from Master to Bypass .....	403, 450	DC Bus Charge LED .....	320
Communication Errors .....	391	DC Bus Overvoltage .....	250
Communication Option Card Reference .....	361	DC Bus Undervoltage .....	156, 244
Communication Parity Selection .....	443	DC Bus Voltage .....	356
Communications Error Operation Selection .....	150	DC Bus Voltage at Previous Fault .....	357
Communications Timing .....	403, 450	DC Injection Braking Current .....	121
Component Names .....	33	DC Injection Braking Start Frequency .....	121
Connecting to a BACnet Network .....	378	DC Injection Braking Time at Start .....	122
Connecting to an N2 Network .....	441	DC Injection Braking Time at Stop .....	122
Connection Diagram - LonWorks Option .....	279	DC Injection Braking to Stop .....	119
Connection Diagram - Non-LonWorks Option .....	279	Deceleration Time .....	139
Control Board Connection Error .....	230, 231	Defaults by Drive Model Selection .....	102
Control Circuit Error .....	230, 231	Device Object .....	389
Control Circuit Terminal Block Functions .....	70	Diagnosing and Resetting Faults .....	257
Control Mode .....	356	Digital Outputs .....	153
Control Mode Features .....	27	Down Arrow Key .....	92
Control Mode Selection .....	27	Drive/kVA Selection .....	348
Control Power Supply Voltage Fault .....	244	Drive Capacity Setting Fault .....	252
Cooling Fan Maintenance .....	360	Drive Cooling Fans .....	285
Cooling Fan Maintenance Setting (Operation Time) .....	349	Drive Derating Data .....	324
Cooling Fan Maintenance Time .....	248	Drive Faults with Apogee Configuration .....	436
Cooling Fan Operation Time .....	360	Drive Mode .....	99
Cooling Fan Operation Time Setting .....	185	Drive Model Selection .....	185
Cooling Fan Replacement .....	239	Drive Mode Unit Monitor Selection .....	183
Cooling Tower Fan Application .....	109		



Drive Nameplate .....	28	Fan Application .....	108
Drive Operation Status at Previous Fault .....	357	Fan with PI Control Application .....	108
Drive Overheat Pre-Alarm .....	159	Fast Stop Time .....	139
Drive Overheat Warning .....	249	Fault Causes and Solutions .....	229
Drive Overload .....	241	Fault Detection .....	229
Drive Ready .....	156	Fault Displays .....	229, 245
Drive Specifications .....	320	Fault History .....	195
Drive Status .....	356	Fault Reset Command Active .....	157
Drive Unit Signal Fault .....	231	Fault Reset Interval Time .....	176, 345
Drive Watt Loss Data .....	322	Fault Reset Methods .....	225
During Baseblock .....	159	Fault Reset Operation Selection .....	176, 345
During Baseblock (N.O.) .....	156	Fault Restart .....	174
During Fast Stop .....	160	Faults .....	225, 226
During Reverse .....	159	Fault Trace .....	195, 257
During Run .....	154	FB01 .....	232
During Run 2 .....	159	FB02 .....	232
During Speed Search .....	160	FB03 .....	232
Dynamic Audible Noise Control Function Selection .....	350	FB05 .....	232
Dynamic Audible Noise Control Selection .....	187	FB06 .....	233
Dynamic Noise Control Function .....	187	FB07 .....	233
<b>E</b>		FB08 .....	233
E2-03 .....	255	FB09 .....	234
EEPROM Memory Data Error .....	230	FB10 .....	234
EEPROM Write Error .....	231	FB11 .....	234
EF .....	247	FB12 .....	234
EF0 .....	231, 247	FB13 .....	234
EMC Filter Enable .....	65	FB14 .....	234
EMC Filter Installation .....	458	FB15 .....	235
EMC filter switch SW1 .....	35	FB16 .....	235
EMC filter switch SW2 .....	35	FB17 .....	235
EMC Guidelines .....	458	FB18 .....	235
EMC Guidelines Compliance .....	458	FB19 .....	235
End3 .....	255	FB20 .....	235
End4 .....	255	FB21 .....	236
End5 .....	255	FB22 .....	236
End7 .....	255	FB23 .....	236
Enter Command .....	390, 421	FB24 .....	236
Enter Command Types .....	390	FB25 .....	236
Enter Data from the Motor Nameplate .....	113	FB26 .....	236
ENTER Key .....	92	FbH .....	237, 247
Er-01 .....	255	FbL .....	237, 248
Er-02 .....	255	FE .....	71
Er-03 .....	256	Ferrule Dimensions .....	72
Er-04 .....	256	Ferrule Terminal Types and Sizes .....	73
Er-05 .....	256	Ferrule-Type Wire Terminals .....	72
Er-08 .....	256	Fine-Tuning V/f Control .....	224
Er-09 .....	256	Fn1 .....	236
Er-12 .....	256	Forward/Reverse Run Command Input Error .....	247
Err .....	231	Frequency Accuracy (Temperature Fluctuation) .....	320
European Standards .....	458	Frequency Control Range .....	320
Excessive Motor Oscillation and Erratic Rotation .....	263	Frequency Detection 1 .....	155
Excessive PI Feedback .....	237, 247	Frequency Detection 2 .....	156
Exterior and Mounting Dimensions .....	42	Frequency Detection 3 .....	158
External Fault from Bypass Controller Detection Selection .....	150	Frequency Detection 4 .....	158
External Fault from Bypass Controller Operation Selection .....	150	Frequency Reference .....	142, 355
External Interlock .....	86	Frequency Reference at Previous Fault .....	357
<b>F</b>		Frequency Reference at Reference Loss .....	173, 345
FAn .....	231	Frequency Reference Display Units .....	348
		Frequency Reference from MEMOBUS/Modbus Comm. ....	361
		Frequency Reference Inputs .....	71

Frequency Reference Loss.....	157	Input Phase Loss Protection Selection .....	179, 346
Frequency Reference Loss Detection Selection .....	173, 345	Input Terminal Status .....	356
Frequency Reference Lower Limit.....	143	Input Terminal Status at Previous Fault .....	357
Frequency Reference Monitor Content During PI .....	136	Input Voltage Setting.....	145
Frequency Reference Selection 1.....	260	Inrush Prevention Circuit Fault .....	244
Frequency Reference Setting / Decimal Display .....	348	Inspection .....	284, 285
Frequency Reference Setting and User-Set Display .....	348	Installation Area .....	40
Frequency Reference Source Selection.....	361	Installation Environment.....	40
Frequency Reference Upper Limit .....	143	Installation Orientation.....	41
Frequency Setting Resolution.....	320	Installation Orientation and Spacing .....	41
Frequency Setting Signal .....	320	Installation Spacing.....	41
Function Code.....	404	Installing the Cooling Fan .....	295
Functions for Terminals S1 to S7.....	151	Integral Limit Setting.....	131
<b>G</b>		Integral Time Setting (I) .....	131
GF.....	237	Interlock Open .....	248
Ground Fault .....	237	Internal Cooling Fan Alarm .....	160
Ground Protection .....	320	inTLK .....	248
Ground Terminal.....	35, 36	<b>J</b>	
Ground Wiring.....	64	Jumper S1 .....	35
<b>H</b>		Jumper S1 Settings .....	85
H3-01 .....	85	Jumper S5.....	35
H3-09.....	85	Jump Frequency.....	144, 224
H3-13.....	224, 264	Jump Frequency Width .....	144
H3 Multi-Function Analog Input Settings.....	342	<b>K</b>	
HAND Key .....	92	Keys and Displays on the HOA Keypad.....	92
HAND Light.....	92	kWh.....	360
HAND Speed Reference Selection .....	206	kWh, Lower 4 Digits .....	360
HCA .....	248	kWh, Upper 5 Digits .....	360
Heatsink Overheat .....	239, 249	<b>L</b>	
Heatsink Overheat Protection .....	320	L3-01 through L3-06 .....	224
Heatsink Temperature.....	360	L3-02 .....	264
High Slip Braking .....	181	L3-04 .....	263
High-slip Braking oL.....	241	L3-11 .....	224
High Slip Braking Overload Time.....	181	LCD Contrast Control.....	209
High-Slip Braking Overload Time .....	347	LCD Display .....	93
HOA Keypad.....	31	LED Check .....	360
HOA Keypad Battery Voltage Low.....	229	LF .....	237
HOA Keypad Connection Fault .....	241	LF2 .....	238
HOA Keypad Display Selection.....	183, 348	Line-to-Line Resistance Error.....	256
HOA Keypad Functions .....	185	Load Inertia Ratio.....	173, 345
HOA Keypad Menu Structure .....	97	Load Verification Fault Select .....	208
HOA Keypad Parameter Display.....	97	Loopback Test.....	406
Humidity .....	40, 320	Loss of Load.....	245
Hunting Prevention.....	181	Loss of Reference Function .....	173
Hunting Prevention Gain .....	224	Low Voltage Directive.....	458
Hunting Prevention Gain Setting.....	181, 347	LT-1 .....	248
Hunting Prevention Selection .....	181, 347	LT-2 .....	248
Hybrid IC Failure .....	231	LT-3 .....	249
<b>I</b>		LT-4 .....	249
I/O Connections.....	84	<b>M</b>	
IGBT Maintenance .....	360	Main Circuit Terminal and Motor Wiring.....	63
IGBT Maintenance Time (50%).....	249	Main Circuit Terminal Block Configuration.....	60
IGBT Maintenance Time (90%) .....	250	Main Circuit Terminal Functions.....	62
Initialization .....	118	Main Circuit Wiring.....	56
Input Current .....	316, 317, 318, 319	Main Control Functions.....	320
Input Phase Detection Level .....	346	Main Input Circuit Wiring.....	67
Input Phase Loss .....	242	Maintenance .....	287
Input Phase Loss Detection Level.....	179		

Maintenance Alarms .....	288	Motor Rotates Faster Than the Frequency Reference.....	262
Maintenance Monitors .....	195	Motor Rotates in One Direction Only.....	261
Maintenance Monitor Settings .....	185	Motor Stalls During Acceleration or With Large Loads .....	262
Maintenance Period .....	159	Motor Underload.....	243
Master Speed Reference Lower Limit .....	143	Motor Underload Protection Level at Minimum Frequency.....	179, 346
Maximum Applicable Motor Capacity .....	316, 317, 318, 319	Motor Underload Protection Selection.....	178, 346
Maximum Output Frequency.....	316, 317, 318, 319	Motor Wiring.....	63
Maximum Output Voltage.....	316, 317, 318, 319	Multi-Function Analog Inputs .....	160
Maximum Voltage.....	148	Multi-Function Analog Input Selection Error.....	253
MEMOBUS/Modbus Comm. Test Mode Complete.....	250	Multi-Function Analog Input Terminal Settings .....	161
MEMOBUS/Modbus Communication Error.....	229, 247	Multi-Function Analog Outputs .....	165
MEMOBUS/Modbus Communications Reference.....	361	Multi-Function Analog Output Terminal AM Bias .....	166
MEMOBUS/Modbus Data Table.....	408	Multi-Function Analog Output Terminal AM Gain.....	166
MEMOBUS/Modbus Error Codes .....	422	Multi-Function Analog Output Terminal AM Monitor Selection.....	165
MEMOBUS/Modbus Setup Parameters .....	400	Multi-Function Analog Output Terminal AM Signal Level Selection ..	167
MEMOBUS/Modbus Specifications .....	397	Multi-Function Analog Output Terminal FM Bias.....	166
Message Format.....	404	Multi-Function Analog Output Terminal FM Gain .....	166
Metasys N2 Point Database .....	451	Multi-Function Analog Output Terminal FM Monitor Selection .....	165
Minimum Current Detection Level during Speed Search.....	126	Multi-Function Analog Output Terminal FM Signal Level Selection...	167
Minimum Wait Time for Sending Messages.....	403, 450	Multi-Function Digital Input Terminal Settings.....	151
Minor Alarms .....	226	Multi-Function Digital Outputs .....	153
Minor Fault .....	255	Multi-Function Input Selection Error .....	252
Minor Fault and Alarm Displays .....	227	Multiple Connection Diagram .....	379, 399, 426, 442
Minor Faults .....	226	Multi-Step Speed Selection.....	142
Minor Faults and Alarms .....	225, 226		
Model Number and Nameplate Check .....	28	<b>N</b>	
Modes .....	99	n1-02.....	224
Modified Constants.....	100	N2 Configuration .....	440
Momentary Overcurrent Protection .....	320	N2 Serial Communication .....	443
Momentary Power Loss Minimum Baseblock Time.....	170, 344	N2 Setup Parameters .....	443
Momentary Power Loss Operation Selection.....	125, 344	N2 Specifications .....	440
Momentary Power Loss Ride-Thru .....	169, 320	Network Digital Input Select.....	217
Momentary Power Loss Ride-Thru Time .....	170, 344	Network Termination .....	378, 399, 442
Monitor Parameters.....	165, 354	No-Load Current Alarm .....	255
Most Recent Fault .....	358	No-Load Current Error.....	256
Motor 1 Parameters.....	149	Notes on Stationary Auto-Tuning .....	112
Motor Base Frequency.....	113, 115, 352	nSE .....	238
Motor Base Speed .....	115, 352	Number of Auto Restart Attempts.....	174, 345
Motor Data Error.....	255	Number of Motor Poles .....	115, 352
Motor d-Axis Current at Previous Fault.....	357	Number of Run Commands .....	360
Motor Does Not Rotate .....	260	Number of Speed Search Restarts .....	127
Motor Hunting and Oscillation Control Parameters .....	224		
Motor Iron Loss.....	115, 353	<b>O</b>	
Motor is Too Hot .....	261	oC.....	238
Motor No-Load Current.....	149	oFA00 .....	239
Motor Overheat .....	249	OFF button Input .....	256
Motor Overheat Alarm (PTC Input).....	239	OFF Key .....	92
Motor Overheat Fault (PTC Input).....	240	oH .....	239, 249
Motor Overload.....	240	oH1 .....	239
Motor Overload Estimate (oL1) .....	360	oH2 .....	249
Motor Overload Protection Selection .....	168, 344	oH3 .....	239, 249
Motor Overload Protection Time .....	169, 344	oH4 .....	240
Motor Performance Fine-Tuning .....	224	oH Pre-Alarm Time Limit.....	160
Motor Poles.....	113	oL1.....	240
Motor Protection .....	168, 320	oL2.....	241
Motor Pull Out or Step Out Detection .....	243	oL3.....	241, 249
Motor q-Axis Current at Previous Fault.....	357	oL7.....	241
Motor Rated Current .....	113, 115, 149, 352	Online Gateway.....	362
Motor Rated Power.....	114, 352	Online IP Address .....	362
Motor Rated Voltage.....	113, 114, 352	oPE .....	252

oPE01 ..... 252

oPE02 ..... 252

oPE03 ..... 252

oPE05 ..... 253

oPE07 ..... 253

oPE09 ..... 253

oPE10 ..... 253

oPE11 ..... 253

oPE28 ..... 254

oPE29 ..... 254

oPE Fault Parameter ..... 357

Operation Errors ..... 225, 227

Operation Status Monitors ..... 195

Operator Related Settings ..... 183

oPr ..... 241

Option Card Connection Error at Option Port CN5 ..... 239

Option card connector (CN5) ..... 36

Option Card External Fault ..... 231, 247

Option Communication Error ..... 229, 246

Option Frequency Reference ..... 361

Option Installation Procedure ..... 271

Option Programming and Troubleshooting ..... 280

Oscillation or Hunting ..... 264

Output Current ..... 356

Output Current 1 during Speed Search ..... 125

Output Current 2 During Speed Search (Speed Estimation Type) ..... 126

Output Current at Previous Fault ..... 357

Output Current Imbalance ..... 238

Output Frequency ..... 355

Output Frequency after Soft Start ..... 356

Output Frequency at Previous Fault ..... 357

Output Frequency is not as High as Frequency Reference ..... 264

Output Frequency Resolution ..... 320

Output Ground Fault Detection Selection ..... 180, 346

Output Phase Loss ..... 237

Output Phase Loss Protection ..... 346

Output Phase Loss Protection Selection ..... 179

Output Power ..... 356

Output Power at Previous Fault ..... 357

Output Terminal Status ..... 356

Output Terminal Status at Previous Fault ..... 357

Output Voltage at Previous Fault ..... 357

Output Voltage Detection Fault ..... 244, 251

Output Voltage Reference ..... 356

ov ..... 241, 250

ov2 ..... 242

Overcurrent ..... 238

Overexcitation Deceleration Gain ..... 182, 347

Overheat 1 (Heatsink Overheat) ..... 239

Overheat Alarm Level ..... 179, 346

Overload Protection ..... 320

Overload Tolerance ..... 316, 317, 318, 319

Overtorque 1 ..... 249

Overtorque Detection 1 ..... 241

Overtorque Detection Operation ..... 177

Overvoltage ..... 241

Overvoltage 2 ..... 242

Overvoltage Protection ..... 320

Overvoltage Suppression Function Selection ..... 172

ov Suppression Function Selection ..... 345

**P**

Parameter Range Setting Error ..... 252

Parameter Settings ..... 99

Parameter Settings for APOGEE FLN ..... 424

Parameters to Minimize Motor Hunting and Oscillation ..... 224

PASS ..... 250

Peak Hold Current ..... 360

Peak Hold Output Frequency ..... 360

Performance Life ..... 287

Performance Life Monitors Maintenance Monitors ..... 287

Periodic Inspection ..... 285

Periodic Maintenance ..... 287

Peripheral Devices & Options ..... 267

PF ..... 242

PI Accel/Decel Time ..... 135

PI Feedback ..... 361

PI Feedback High Detection Level ..... 134

PI Feedback High Detection Time ..... 134

PI Feedback Loss ..... 237, 248

PI Feedback Loss Detection Selection ..... 133

PI Feedback Low Detection Level ..... 133

PI Feedback Low Detection Time ..... 134

PI Function Setting ..... 131

PI Input (feedback) ..... 361

PI Input Limit ..... 136

PI Monitors ..... 195

PI Offset Adjustment ..... 131

PI Output ..... 361

PI Output Fault ..... 264

PI Output Gain Setting ..... 132

PI Output Level Selection ..... 132

PI Output Limit ..... 131

PI Output Lower Limit ..... 136

PI Output Reverse Selection ..... 132

PI Primary Delay Time Constant ..... 131

PI Setpoint ..... 361

PI Setpoint Display Digits ..... 136

PI Setpoint Monitor Unit Selection ..... 136

PI Setpoint Scaling ..... 135

PI Setpoint Selection ..... 135

PI Setpoint User Display ..... 136

PI Setpoint Value ..... 135

PI Sleep/Snooze ..... 134

PI Sleep Delay Time ..... 135

PI Sleep Function Start Level ..... 135

Powering Up the Drive ..... 103

Power Ratings (Three-Phase 208 V) ..... 316, 317

Power Ratings (Three-Phase 480 V) ..... 318, 319

Predefined V/f Patterns ..... 145

Preface ..... 14

Prepare Network Cables for Non-LonWorks Options ..... 272

Prepare Network Cables for SI-W3 LonWorks Option ..... 271

Preparing the Ends of Shielded Cables ..... 84

Present Value Access ..... 383

Preset Reference Timing Diagram ..... 142

Previous Fault ..... 355, 357

Previous Fault Hour Minute ..... 355

Previous Fault Month Day ..... 355

Previous Fault Year ..... 355

Programmable Run Timers for Real Time Clock (RTC).....	188	Sequence Timer 1 Start Time .....	350
Programming Errors.....	252	Sequence Timer 1 Stop Time .....	350
Programming Mode .....	99	Sequence Timer 2 Day Selection .....	351
Proportional Gain Setting (P) .....	131	Sequence Timer 2 Reference Source .....	351
Protection Design.....	320	Sequence Timer 2 Selection .....	351
Protective Cover .....	80	Sequence Timer 2 Start Time .....	350
Protective Covers, Reattaching .....	74	Sequence Timer 2 Stop Time .....	351
Protective Covers, Removing .....	73	Sequence Timer 3 Day Selection .....	351
Pump (Secondary) Application .....	110	Sequence Timer 3 Reference Source .....	351
Pump with PI Control Application .....	110	Sequence Timer 3 Selection .....	351
<b>Q</b>		Sequence Timer 3 Start Time .....	351
Quick Setting Group.....	101	Sequence Timer 3 Stop Time .....	351
Quick Setting Group Parameters .....	101	Sequence Timer 4 Day Selection .....	352
<b>R</b>		Sequence Timer 4 Reference Source .....	352
R/L1 .....	62	Sequence Timer 4 Selection .....	352
Ramp to stop .....	119	Sequence Timer 4 Start Time .....	351
Rated Current Setting Alarm .....	255	Sequence Timer 4 Stop Time .....	351
Rated Output Current.....	316, 317, 318, 319	Sequence Timer Error .....	254
Rated Slip Error.....	256	Sequence Timers 1/2/3/4 Reference Source .....	190
Rated Voltage, Rated Frequency .....	316, 317, 318, 319	Sequence Timers 1/2/3/4 Selection .....	190
Reading BACnet Bypass Parameters .....	390	Sequence Timers 1 to 4 Day Selection .....	189
Reading Drive MEMOBUS/Modbus Register Contents .....	406	Sequence Timers 1 to 4 Start Time .....	189
Real Time Clock .....	188	Sequence Timers 1 to 4 Stop Time .....	189
Reattaching the Front Cover .....	79	Sequence Timers 2 to 4 .....	189
Reattaching the Terminal Cover .....	74	SER .....	243
Removing the Cooling Fan .....	293	Serial Comm Fault.....	245
Removing the Front Cover .....	75	Serial Communication Fault Detection Selection .....	444
Removing the Terminal Cover.....	73	Serial Communications Cable Connection Terminal (TB3) ..	378, 398, 441
Replacement Parts .....	287	Serial Communications Fault Time Select .....	444
RESET Key.....	92	Serial Communications Node Address Select .....	443
Resistance Tuning Error .....	255	Serial Communications Protocol Select .....	443
Response Messages from Drive to Master .....	403, 450	Serial Communications Receive to Transmit Wait Time.....	444
Restart Delay .....	210	Serial Communication Terminals.....	72
Restart Enabled .....	159	Serial Communication Transmission Error .....	246
Return Fan with PI Control Application.....	108	Setup Mode.....	101
Reverse Operation Selection .....	121	Shielded Twisted-Pair Cables .....	84
Reverse Operation Selection 2 by PI Output.....	137	Simplified Setup Using the Quick Setting Group .....	101
Rotational Auto-Tuning for V/f Control.....	111	Slave Address .....	404
RS-485 Interface .....	399	Smoke Purge in Bypass.....	245
Run Active during Restart Delay .....	245	Smoke Purge in Drive.....	245
Run Command/Frequency Reference Source Selection Error.....	253	Soft Charge Bypass Relay Maintenance.....	360
Run Command Selection .....	260	Soft Charge Bypass Relay Maintenance Time.....	249
Run Command Source Selection .....	361	Soft Starter Speed Reference at Previous Fault.....	357
<b>S</b>		Software No. (Flash) .....	357
S: Special Parameters .....	187, 350	Software No. (ROM).....	357
S/L2.....	62	Software version .....	29
S1: Dynamic Noise Control Function.....	350	Speed Agree 1.....	154
S2: Sequence Timers.....	188, 350	Speed Agree 2.....	157
SAFE .....	250	Speed Control Range.....	320
Safety Open Message Selection .....	213	Speed Estimation Type Speed Search.....	123
Safety Standard .....	320	Speed Search .....	119
S-Curve Characteristics .....	139, 224	Speed Search Deactivation Current .....	125
SE.....	250	Speed Search Deceleration Time .....	125
Selecting the Type of Auto-Tuning .....	112	Speed Search Delay Time .....	125
Sequence Timer 1.....	188	Speed Search Detection Compensation Gain .....	126
Sequence Timer 1 Day Selection.....	350	Speed Search Method Selection .....	127
Sequence Timer 1 Reference Source.....	350	Speed Search Method Switching Level (Speed Estimation Type).....	126
Sequence Timer 1 Selection.....	350	Speed Search Restart Current Level.....	127
		Speed Search Restart Detection Time.....	127
		Speed Search Selection at Start.....	125

Speed Search Wait Time.....	127	Types of Alarms, Faults, and Errors .....	225
Stall Prevention .....	170, 224, 320	Types of Auto-Tuning for Induction Motors.....	111
Stall Prevention Level during Acceleration .....	170, 344	<b>U</b>	
Stall Prevention Level during Run .....	172, 345	U/T1 .....	62
Stall Prevention Limit during Acceleration .....	171, 344	U1-01 .....	262
Stall Prevention Selection during Deceleration.....	171, 345	U1-07 .....	260
Standard Connection Diagram .....	52	U2-00, U3-00, and UB-00 Initialization .....	185
Starting Torque.....	320	UL3 .....	243, 250
Start Speed Search Select.....	127	UL6 .....	243, 251
Stationary Auto-Tuning.....	112	UL and CSA Standards .....	459
Stationary Auto-Tuning for Line-to-Line Resistance .....	111	UL Standards Compliance.....	62
Status Display .....	103	Undertorque Detection 1.....	243, 250
STo .....	243	Undertorque Detection 6.....	251
Stopping Method after Communication Error .....	167	Undertorque Detection Operation .....	177
Stopping Method Selection.....	119	Undervoltage .....	251
Storage Temperature .....	40, 320	Undervoltage 3 .....	244
Supported Properties of Objects .....	383	Undervoltage 3 (Soft-Charge Circuit Fault).....	244
Surrounding Area .....	40	Undervoltage Detection Level (Uv1) .....	170, 344
Swing PWM.....	140	Undervoltage Protection .....	320
<b>T</b>		Unexpected Noise from Connected Machinery.....	263
T/L3.....	62	Unit Code .....	185
T1-03 .....	113	Up/Down Command Operation.....	152
T1-04 .....	113	Up Arrow Key.....	92
T1-05 .....	113	User Monitor Selection after Power Up .....	183
T1-06 .....	113	User-Set Display Units Decimal Display.....	185
T1-07 .....	113, 114	User-Set Display Units Maximum Value.....	185
TdE .....	243	User-Set Speed Agree 1.....	155
Terminal A1 Bias Setting.....	161	User-Set Speed Agree 2.....	157
Terminal A1 Function Selection.....	161	Uv .....	251
Terminal A1 Gain Setting .....	161	Uv1 .....	244
Terminal A1 Signal Level Selection .....	160	Uv2 .....	244
Terminal A2 Bias Setting.....	162	Uv3 .....	244
Terminal A2 Function Selection.....	162	<b>V</b>	
Terminal A2 Gain Setting .....	162	V/f Characteristics .....	320
Terminal A2 Signal Level Selection .....	162	V/f Control.....	27
Terminal Block Configuration .....	60	V/f Control Mode Tuning .....	224
Terminal Board Connection Error.....	230	V/f Control Mode Tuning Parameters .....	224
Terminal TB1 .....	36	V/f Data Setting Error.....	253
Terminal TB2 .....	36	V/f Gain During Speed Search.....	125
Terminal TB3 .....	35, 36	V/f Pattern Selection .....	145, 262
Terminal TB4 .....	35	V/T2 .....	62
Test Run.....	111, 114	Verifying Parameter Changes.....	100
Through Mode .....	157	Vibration/Shock.....	320
TIM .....	243	voF .....	244, 251
Time Data Error.....	243	Voltage drop calculation formula.....	62
Time Not Set .....	243	Voltage Reduction Rate.....	187, 350
Time to Continue Making Fault Restarts .....	345	Voltage Restoration Complete Level .....	188, 350
Tools Required for Option Installation .....	270	Voltage Restoration Level .....	187, 350
Too Many Speed Search Restarts.....	243	Voltage Restoration Sensitivity Time Constant .....	188, 350
Torque Compensation Gain .....	140, 224	Voltage Restoration Time Constant at Impact.....	188, 350
Torque Compensation Primary Delay Time .....	224	<b>W</b>	
Torque Detection .....	164	W/T3.....	62
Torque Detection 1 .....	157	Waiting for Run .....	251
Torque Detection Level 1.....	178, 346	Warranty Information .....	23
Torque Detection Selection 1 .....	177, 346	Watt Hour Pulse Output .....	160
Torque Detection Time 1 .....	178, 346	Watt Loss 200 V Class Three Phase Models.....	322
Troubleshooting without Fault Display.....	259	Watt Loss 400 V Class Three Phase Models.....	322
TrPC .....	250	Welded K3 Contactor Fault Select .....	209
Tuning Errors.....	225		

---

Wiring Distance.....	141
Wiring the Control Circuit Terminal.....	80
Writing BACnet Bypass Parameters.....	390
Writing to Multiple Registers.....	407
WrUn.....	251
<b>Z</b>	
Z: Bypass Parameters.....	196
Z1000 Bypass Faults with Apogee Configuration.....	436
Zero Speed.....	154

## Revision History

The revision dates and the numbers of the revised manuals appear on the bottom of the back cover.

Example:

MANUAL NO. SIEP YAIZ1B 01D

Published in U.S.A. September 2014 12-1 3

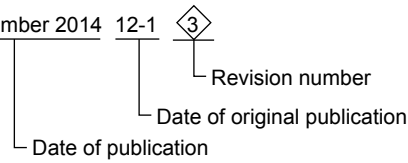

Date of Publication	Revision Number	Section	Revised Content
March 2018	<6>	All	Updated documentation to support bypass controller software version VST800401.
May 2017	<5>-1	Preface	Revision: Removed restrictions
August 2016	<5>	Chapter 7	Added: Peripheral Devices & Options - Communication option installation procedure.
April 2016	<4>	All	Updated documentation to support bypass controller software version VST800400.
September 2014	<3>	All	Updated documentation to support bypass controller software version VST800298 and drive software version PRG: 1017.
February 2014	<2>	All	Added: Bypass model Z1B1B52L and corresponding data.
May 2013	<1>	All	Added: Appendices E and F. This manual revised to support bypass controller software version VST800295 and drive software version PRG: 1015.
January 2012	-	-	First Edition. This manual supports bypass controller software version VST800292 and drive software version PRG: 1012.



---

**This Page Intentionally Blank**

# YASKAWA AC Drive Z1000 Bypass

## AC Drive Bypass for HVAC Fans and Pumps

### Technical Manual

---

**YASKAWA AMERICA, INC.**

2121 Norman Drive South, Waukegan, IL 60085, U.S.A.  
Phone: (800) YASKAWA (927-5292) or 1-847-887-7000 Fax: 1-847-887-7310  
<http://www.yaskawa.com>

**DRIVE CENTER (INVERTER PLANT)**

2-13-1, Nishimiyaichi, Yukuhashi, Fukuoka, 824-8511, Japan  
Phone: 81-930-25-3844 Fax: 81-930-25-4369  
<http://www.yaskawa.co.jp>

**YASKAWA ELECTRIC CORPORATION**

New Pier Takeshiba South Tower, 1-16-1, Kaigan, Minatoku, Tokyo, 105-6891, Japan  
Phone: 81-3-5402-4502 Fax: 81-3-5402-4580  
<http://www.yaskawa.co.jp>

**YASKAWA ELÉTRICO DO BRASIL LTDA.**

Avenda Fagundes Filho, 620 Bairro Saude, São Paulo, SP04304-000, Brasil  
Phone: 55-11-3585-1100 Fax: 55-11-5581-8795  
<http://www.yaskawa.com.br>

**YASKAWA EUROPE GmbH**

Hauptstrasse 185, 65760 Eschborn, Germany  
Phone: 49-6196-569-300 Fax: 49-6196-569-398  
<http://www.yaskawa.eu.com>

**YASKAWA ELECTRIC UK LTD.**

1 Hunt Hill Orchardton Woods, Cumbernauld, G68 9LF, United Kingdom  
Phone: 44-1236-735000 Fax: 44-1236-458182  
<http://www.yaskawa.co.uk>

**YASKAWA ELECTRIC KOREA CORPORATION**

7F, Doore Bldg, 24, Yeoido-dong, Yeongdungpo-gu, Seoul, 150-877, Korea  
Phone: 82-2-784-7844 Fax: 82-2-784-8495  
<http://www.yaskawa.co.kr>

**YASKAWA ELECTRIC (SINGAPORE) PTE. LTD.**

151 Lorong Chuan, #04-01, New Tech Park, 556741, Singapore  
Phone: 65-6282-3003 Fax: 65-6289-3003  
<http://www.yaskawa.com.sg>

**YASKAWA ELECTRIC (SHANGHAI) CO., LTD.**

No. 18 Xizang Zhong Road, 17F, Harbour Ring Plaza, Shanghai, 200001, China  
Phone: 86-21-5385-2200 Fax: 86-21-5385-3299  
<http://www.yaskawa.com.cn>

**YASKAWA ELECTRIC (SHANGHAI) CO., LTD. BEIJING OFFICE**

Room 1011, Tower W3 Oriental Plaza, No. 1 East Chang An Ave.,  
Dong Cheng District, Beijing, 100738, China  
Phone: 86-10-8518-4086 Fax: 86-10-8518-4082

**YASKAWA ELECTRIC TAIWAN CORPORATION**

9F, 16, Nanking E. Rd., Sec. 3, Taipei, 104, Taiwan  
Phone: 886-2-2502-5003 Fax: 886-2-2505-1280

---

# YASKAWA

## YASKAWA AMERICA, INC.

In the event that the end user of this product is to be the military and said product is to be employed in any weapons systems or the manufacture thereof, the export will fall under the relevant regulations as stipulated in the Foreign Exchange and Foreign Trade Regulations. Therefore, be sure to follow all procedures and submit all relevant documentation according to any and all rules, regulations and laws that may apply.

Specifications are subject to change without notice for ongoing product modifications and improvements.

© 2012-2019 YASKAWA AMERICA, INC. All rights reserved.



SIEPYAIZ1B01

MANUAL NO. SIEP YAIZ1B 01F <6>-1

Published in U.S.A. March 2018 12-1