

# Power Amplifiers with CNC Adaptation Modules

## EEA-PAM-5\*\*-F-32 Series

### General Description

The EEA-PAM-5\*\*-F-32 Eurocards are power amplifiers with integrated CNC adaptation modules. Each card replaces two conventional electronic cards.

These power amplifiers are used for high accuracy positioning systems with inexpensive standard proportional valves and CNC axis or PLC position controls.

### Features and Benefits

- Includes all features of “A” amplifiers
- Hysteresis compensation for valves with/without feedback
- Enhanced deadband adjustment for closed-loop position control using valves with overlap
- This particular configuration reduces the amount of external wiring, saves space in the rack enclosure and requires only one 24V power supply
- Smooth transition between the overlap region and working region
- Low cost, high accuracy positioning systems with overlapped proportional valves. Non-linearities and inconsistencies (friction) in the overlap region are compensated by the electronic linearization
- Simple set-up procedure
- A built-in test function significantly simplifies commissioning (start-up) and fault-diagnosis

### Front Panel

#### LEDs

- [1] 24V power supply input, green
- [2] 15V control supply output, green
- [3] Drive (solenoid) enabled, yellow
- [4] Overload, red
- [5] LVDT failure, red
- [6] Drive level to solenoid, yellow

#### Potentiometer

- [7] Offset

#### LED

- [8] Ramps enabled, yellow

#### Potentiometers

- [9] Acceleration ramp
- [10] Deceleration ramp

#### Monitor points ■

- [11] MP1: Conditioned command signal
- [12] Common ground (0V)
- [13] MP2: LVDT (spool) position ▲

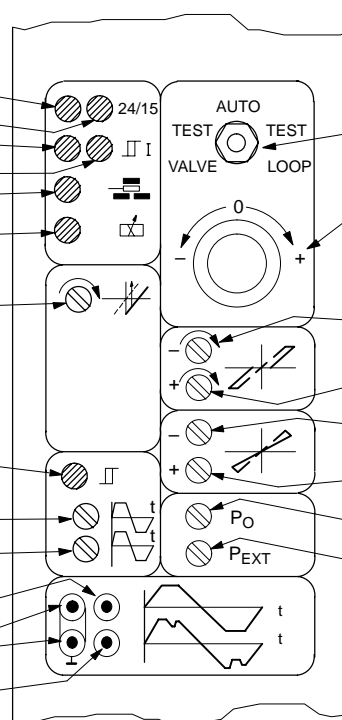

- [14] Mode switch
  - TEST VALVE setting
  - AUTO function setting
  - TEST LOOP setting

- [15] Test potentiometer

#### Potentiometers

- [16] Deadband compensation
- [17] Deadband compensation
- [18] Gain
- [19] Gain
- [20] Deadband gain
- [21] P-gain controller

■ Ø2,0 mm (0.0787" dia.) sockets.

▲ Solenoid current for EEA-PAM-523/525-F models.



This product has been designed and tested to meet specific standards outlined in the European Electromagnetic Compatibility Directive (EMC) 89/336/EEC, amended by 91/263/EEC, 92/31/EEC and 93/68/EEC, article 5. For instructions on installation requirements to achieve effective protection levels, see this leaflet and the Installation Wiring Practices for Vickers Electronic Products leaflet 2468. Wiring practices relevant to this Directive are indicated by Electromagnetic Compatibility (EMC).

## Model Codes

Amplifier model	For valves
EEA-PAM-523-F-32	KDG4V-3 } With type "H" KDG4V-5 } coils only
EEA-PAM-525-F-32	
EEA-PAM-533-F-32	KFDG4V-3
EEA-PAM-535-F-32	KFDG4V-5
EEA-PAM-561-F-32	KFDG5V-5/7
EEA-PAM-568-F-32	KFDG5V-8
EEA-PAM-581-F-32	KHDG5V-5/7/8

## Operating Data

Power (input) supply	bdz32	See appropriate base amplifier, e.g. for EEA-PAM-535-F-32 see EEA-PAM-535-A-32
Control (output) supplies	z22	+15V for LVDTs only
Reference voltages	z2 b2	+10V x 5 mA -10V x 5 mA
Analog inputs:		
Command inputs		
Direct-voltage inputs	b6, b8, b10, z8	
Inverting-voltage input	z10	
Voltage range		± 10V
Input impedance (voltage)		47 kΩ
Current input	d28	
Current range		± 20 mA
Input impedance (current)		100Ω
Input ramp		Can be inverted using jumper on plug X30 on circuit board.
Voltage range		± 10V (see circuit diagram on page 4)
Input impedance		10 kΩ
Velocity demand signal	d10, d16	
Voltage range		± 10V
Input impedance		15 kΩ
Digital inputs:		
Drive enable (power available to solenoid)	z24	
Ramps enable	b24	
Enabled		17 to 40V
Disabled		0 to 3,5V
Load current		≤ 10 mA
Analog outputs:		
P-controller output		
Voltage range	d12	± 10V
Load impedance		≥ 10 kΩ; short-circuit proof
Output ramp generator	d26	
Voltage range		± 10V
Load impedance		≥ 10 kΩ; short-circuit proof

Continued on next page

Alarm output: Set alarm Signal	z12	Enable amplifier (on pin z24) when switching power on. HIGH when alarm is activated. Output = Supply volts minus 2 volts. I = 50 mA max. LOW when solenoid overload has occurred. (Maintained until reset). Output = 0 to +/-2 volts. Output resistance = 50 ohms. Disable and re-enable on pin z24.
Reset after failure		
Potentiometers: Deadband compensation, separate control for each solenoid Gain, separate control for each solenoid P <sub>0</sub> -Deadband gain P <sub>EXT</sub> -Gain controller: Without link Link	d18 to d20	0 to 50% 40 to 90% 15 to 43 times  0,1 to 5 times 2 to 100 times
Integrated P-controller		The input circuit of the power amplifier card is used as a differential amplifier between the demand and feedback signals. The ramp signal generator can be used as profile generator.  <b>Caution:</b> When using "TEST LOOP" the command signal has to be connected to d8, and d14 has to be connected to the command signal input of the input stage.
Hysteresis compensation: Link	d2 to d6	For KDG4V-* valves only
Monitor points: Conditioned command signal power amplifier LVDT (spool) position▲ Voltage range Monitor point impedance	MP1 MP2	± 10V 10 kΩ
Ambient conditions: Storage temperature range Operating temperature range		-25 to +85°C (-13 to +185°F) 0 to 50°C (32 to 122°F)
Mass		0,4 kg (0.88 lb) approx.
Installation and start-up guidelines (supplied with product) Installation wiring requirements for Vickers electronic products Application notes (available on request)		9171 2468 9059
Integrated test modes		See three pages on
Supporting products: Power supply unit options Electronic accessories Portable test equipment		See catalogs: 2419 2460 2462 and 2315

▲ Solenoid current for EEA-PAM-523/525-F models.

# Circuit and Connections

EEA-PAM-5\*\*-F-32

Read circuit in conjunction with that for relevant base amplifier EEA-PAM-5\*\*-A

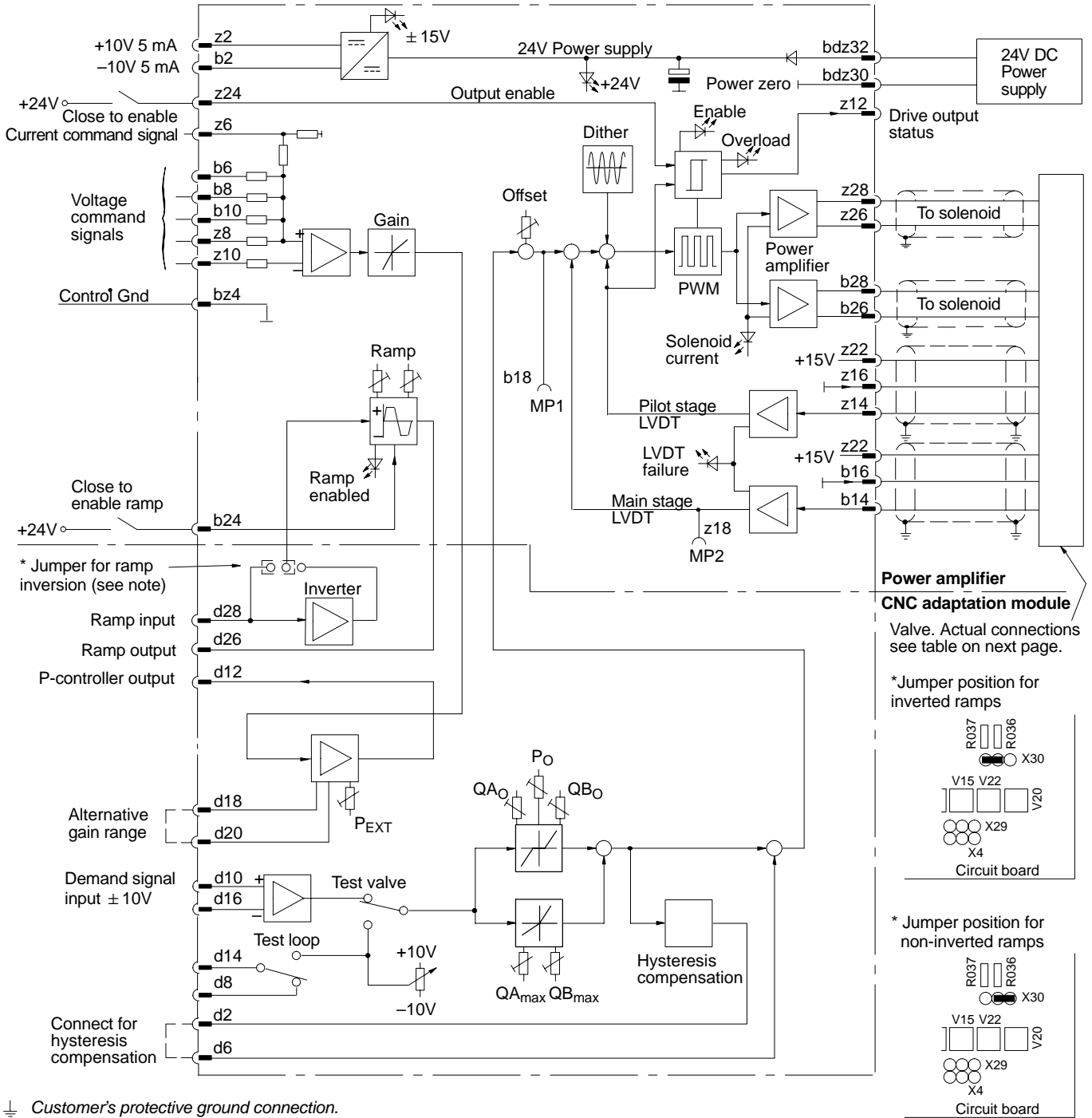

**Warning: Electromagnetic Compatibility (EMC)**

It is necessary to ensure that the valve is wired up in accordance with the connection arrangements shown in this leaflet. For effective protection, the user's electrical cabinet, the valve subplate or manifold and the cable screens should be connected to efficient earth (ground) points. The metal 7-pin connector part no. 934939 should be used for the integral amplifier.

In all cases, both valve and cable should be kept as far away as possible from any source of electromagnetic radiation such as cables carrying heavy current, relays and certain kinds of portable radio transmitters, etc. Difficult environments could mean that extra screening may be necessary to avoid the interference.

# Solenoid and LVDT Connections for Proportional Valves

Amplifier type	Solenoid with LVDT and/or for flow P to B	Solenoid without LVDT, or on pilot valve	Pilot-stage LVDT, (black plug):				Main-stage LVDT, (gray plug):			
			Pin 1	Pin 2	Pin 3	Pin 4	Pin 1	Pin 2	Pin 3	Pin 4
EEA-PAM-523-F-32	b26/b28	z26/z28	-	-	-	Not connected	-	-	-	Not connected
EEA-PAM-525-F-32	b26/b28	z26/z28	-	-	-	Not connected	-	-	-	Not connected
EEA-PAM-533-F-32	b26/b28	z26/z28	-	-	-	Not connected	b14	z22	b16	Not connected
EEA-PAM-535-F-32	b26/b28	z26/z28	-	-	-	Not connected	b14	z22	b16	Not connected
EEA-PAM-561-F-32	-	z26/z28	-	-	-	Not connected	b14	z22	b16	Not connected
EEA-PAM-568-F-32	-	z26/z28	-	-	-	Not connected	b14	z22	b16	Not connected
EEA-PAM-581-F-32	-	z26/z28	z14	z22	z16	Not connected	b14	z22	b16	Not connected

## Installation Dimensions in mm (inches)

Plug-in Unit of 3U Height, to IEC 297

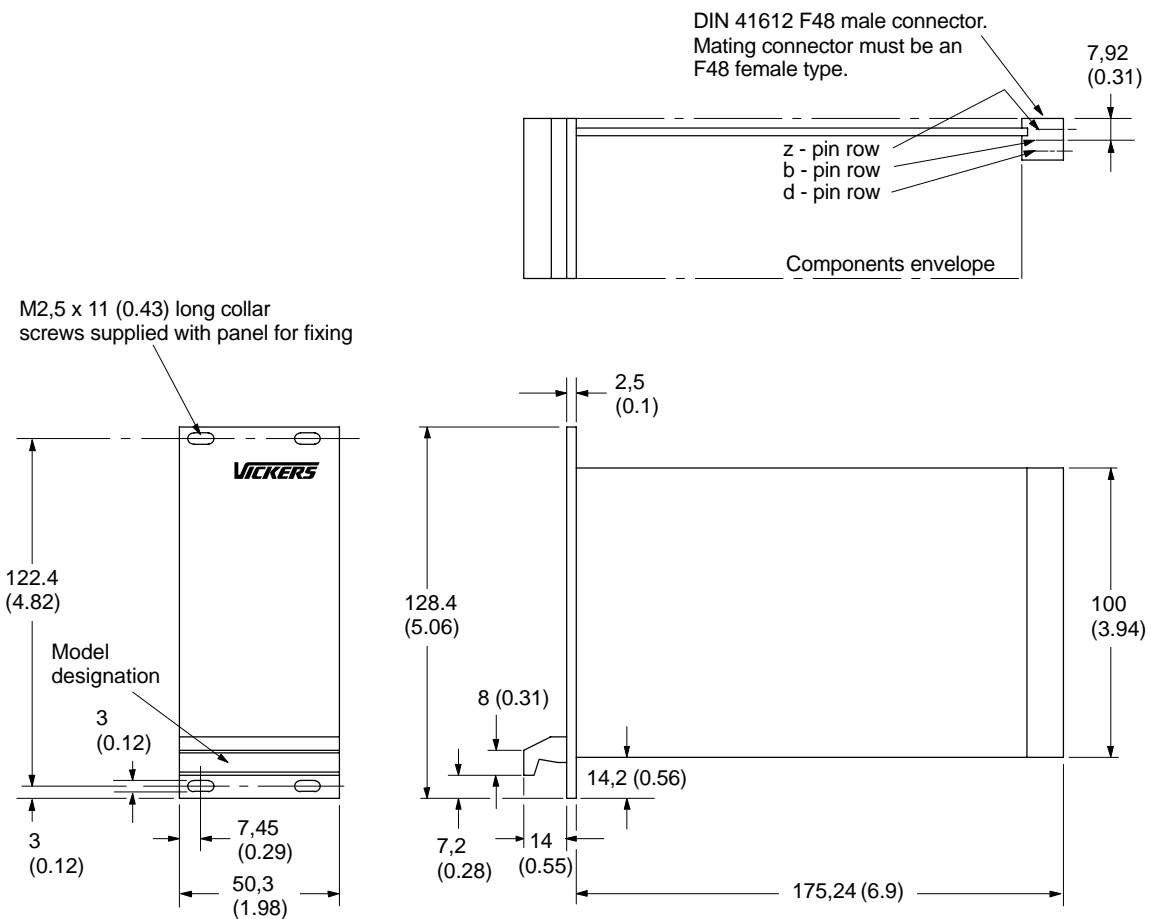

## Operation of the Integrated Test Mode

The basic operation of the hydraulic actuator can be tested by using the 3-position mode switch mounted on the front panel. To select different modes the toggle switch must be lifted slightly before moving to a new position.

### Caution:

Before setting the mode switch to either "Test valve" or "Test loop" make sure the test potentiometer is set to "0". Otherwise sudden movements of the actuator may occur.

The mode switch has three positions:

### AUTO

The controller operates in closed-loop mode, using the external command signal. The test potentiometer is disconnected.

### TEST VALVE

An open-loop command signal for the valve comes directly from the potentiometer. The external input signal is disconnected. The hydraulic part of the system may be tested in this configuration.

### TEST LOOP

The test potentiometer can be used to drive the separate P-controller, if "Test loop" (closed spool) is selected. The external input signal is disconnected. See wiring example. "Test loop" is usable only if the separate P-controller is used.

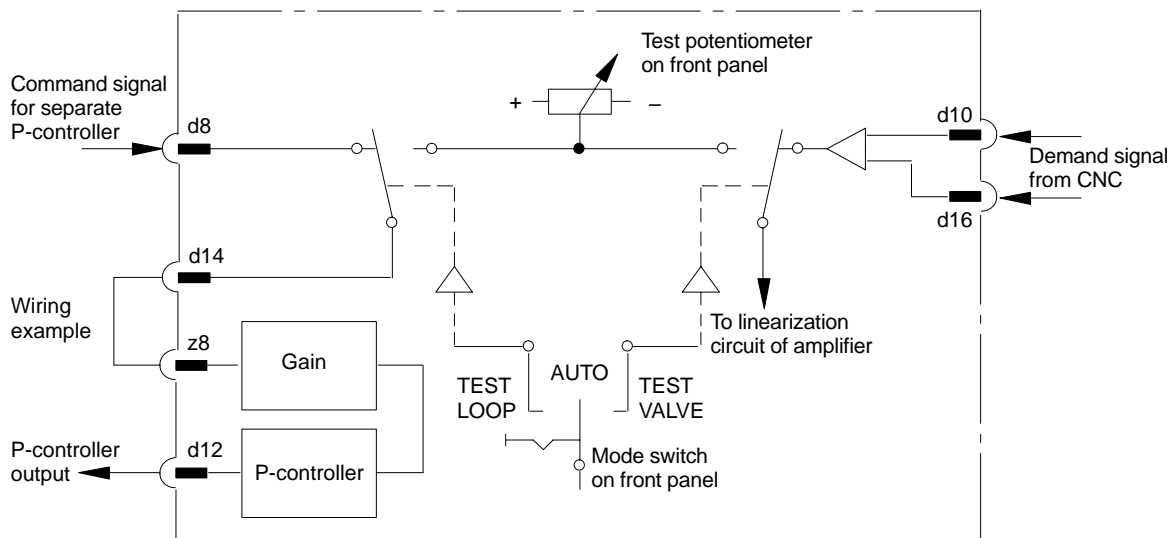

# Application Example

Positioning module with CNC axis controller

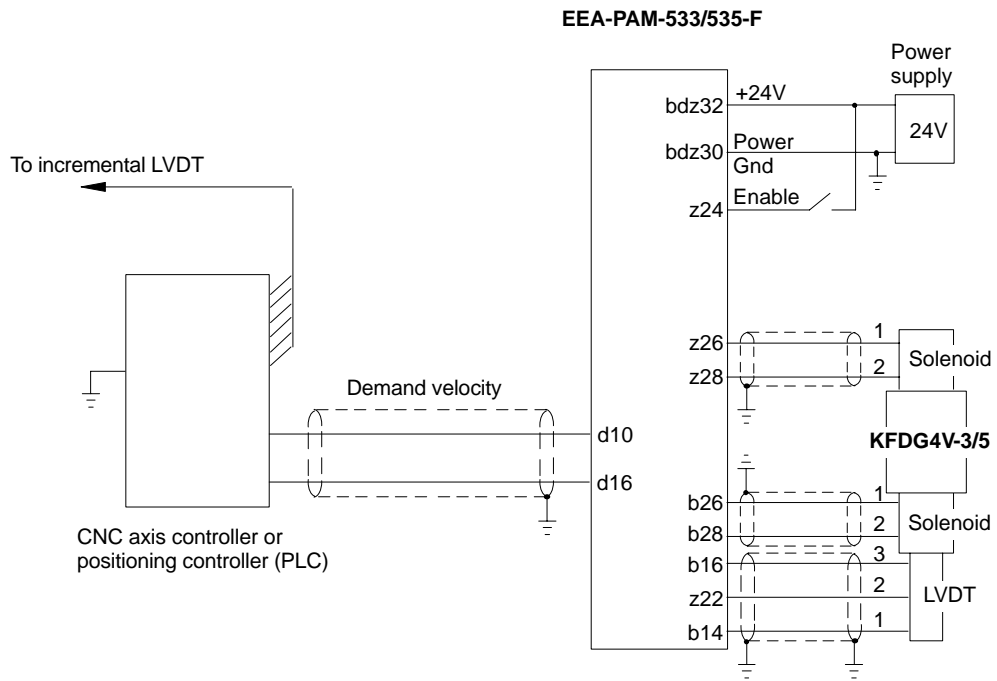

⏏ Customer's protective ground connection.