

ENGINEERING
TOMORROW

Danfoss

Catalog

Vickers by Danfoss

Proportional Two Stage Directional Valves without Electrical Feedback

KBDG5V-5-1*
KBDG5V-7-2*
KBDG5V-8-1*
KBDG5V-10-1*

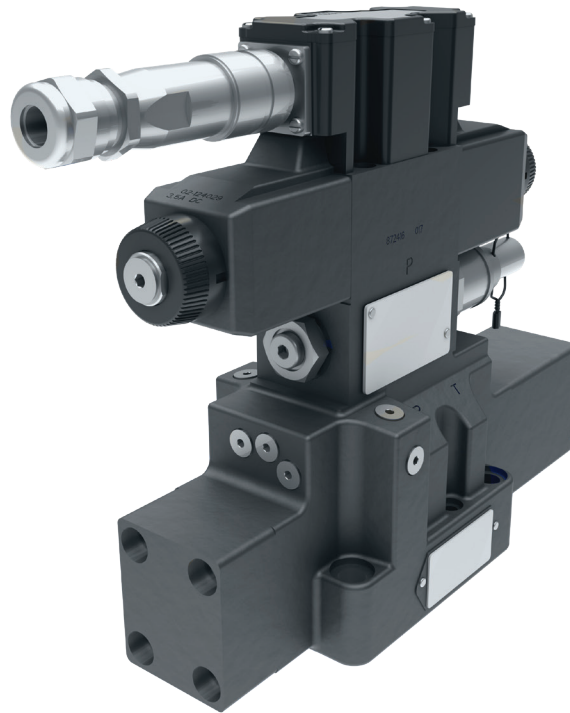

VICKERS
by Danfoss

Contents

General Description	Page 3
Typical Section	Page 3
Model Codes	Page 4
Spool Data	Page 5
Functional Symbols	Page 6
Operating Data	Page 7
Performance Characteristics	Page 8
Power Capacity Envelopes	Page 9
Flow Characteristics	Page 10
Step Response	Page 12
Installation Dimensions	
KBDG5V-5/7/8/10	Page 13
Pilot Supply and Drain Plugs	Page 14
Mounting Faces	Page 15
Electrical Information	
Block Diagram	Page 16
Typical Connection Arrangements	Page 17
Application Data	Page 18



This product has been designed and tested to meet specific standards outlined in the European Electromagnetic Compatibility Directive (EMC) 89/336/EEC, amended by 91/263/EEC, 92/31/EEC and 93/68/EEC, article 5. For instructions on installation requirements to achieve effective protection levels, see this leaflet and the Installation Wiring Practices for Vickers™ Electronic Products leaflet 2468. Wiring practices relevant to this Directive are indicated by  Electromagnetic Compatibility (EMC).

General Description

Vickers by Danfoss KBDG5V-5/7/8/10 are solenoid operated directional control, non-feedback type proportional valves.

These are two-stage proportional directional control valves in which the main-stage spool is positioned according to the output from an integrally mounted proportional, solenoid-operated, pressure-reducing valve. Direction of main-spool travel depends upon which of the two solenoids of the pilot

Valve is energized and the amount of travel is dependent upon the current input to the solenoid.

At any intermediate position of the main spool, a force balance exists between the controlled, reduced pilot pressure acting on the spool end and the opposing centering spring, plus the action of flow forces. There is no electrical feedback of the main-stage spool position.

This range of valves offers effective and economic solutions for applications having repetitive load conditions throughout each operating cycle, e.g. mold closure /opening in plastics molding machinery.

Standard Features and Benefits

- These global products, manufactured to world-class quality standards, are sold and serviced throughout the world.
- These valves open up expanded application opportunities as a cost effective alternative to feedback-type proportional and servo valves.
- Auxiliary DIN-rail mounted function modules available.

Typical Section

KBDG5V-7
With Integral Pilot Pressure Reducer

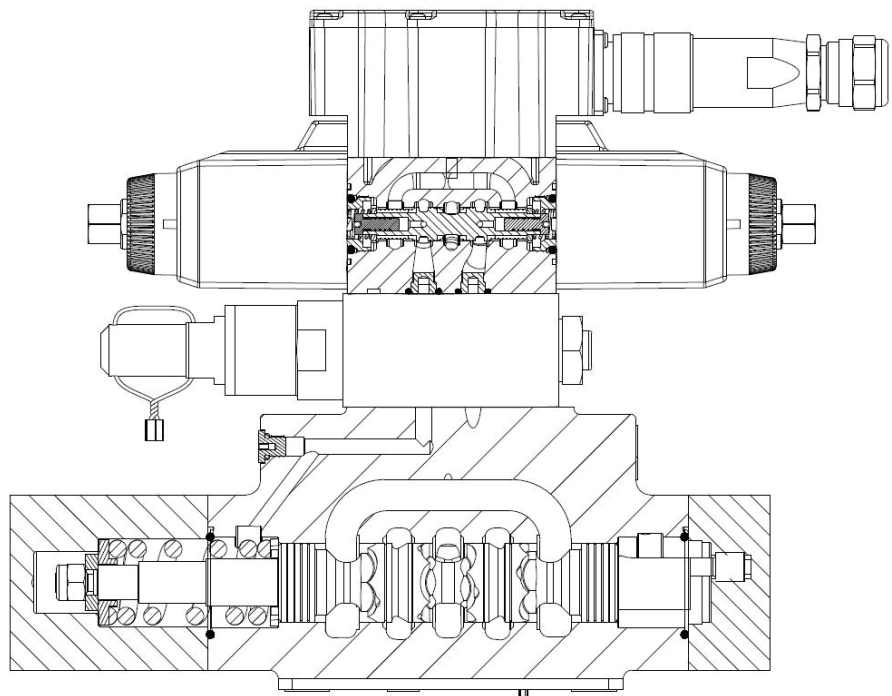

Model Codes

K B D G 5 V _*_* *** (**) (T) (*) ** P*7 *1 ****
1 2 3 4 5 6 7 8 9 10 11 12 13 14 15

1	Valve Type	K Proportional valve
2	Integral amplifier	B Integral Amplifier "B" Series
3	Control Type	D Directional valve
4	Mounting	G Subplate mounted
5	Operation	5 Pilot operated
6	Pressure rating	V Pressure rating on P, A & B ports Sizes 7, 8 and 10: 350 bar (5000 psi) Size 5: 315 bar (4500 psi)
7	Mounting Interface Size (ISO 4401)	5 NFPA D05, CETOP 5 7 NFPA D07, CETOP 7 8 NFPA D08, CETOP 8 10 NFPA D10, CETOP 10
8	Spool Type, flow rating and metering	See 'Functional Symbol' on page 7. p = 5bar (72psi) per metering flow path, e.g. B to T. Symmetric Spools For KBDG5V-5 valves. 2C90N 90 L/min (24 USgpm) 33C80N 80 L/min (21 USgpm) For KBDG5V-7 valves. 2C230N 230 L/min (61.3 USgpm) 33C230N 230 L/min (61.3 USgpm) 36C185N 185 L/min (49.3 USgpm) For KBDG5V-8 valves 2C330N 330 L/min (88 USgpm) 33C330N 330 L/min (88 USgpm) For KBDG5V-10 valves 2C550N 550 L/min (145 USgpm) 7C550N 550 L/min (145 USgpm) 12C550N 550 L/min (145 USgpm) 33C550N 550 L/min (145 USgpm)

Asymmetric Spools

First figure (**N) is flow rating P-A, or A-T ("A" port flow); last figure (N**) is flow rating P-B, or B-T ("B" port flow)

For KBDG5V-5 valves

2C70N45	70 L/min (18.6 USgpm), "A" port flow 45 L/min (12.0 USgpm), "B" port flow
33C60N35	60 L/min (16.0 USgpm), "A" port flow 35 L/min (9.3 USgpm), "B" port flow

For KBDG5V-7 valves

2C230N140	230 L/min (61.3 USgpm), "A" port flow 140 L/min (37.3 USgpm), "B" port flow
33C230N140	230 L/min (61.3 USgpm), "A" port flow 140 L/min (37.3 USgpm), "B" port flow
133C230N140	230 L/min (61.3 USgpm), "A" port flow 140 L/min (37.3 USgpm), "B" port flow

For KBDG5V-8 valves

2C330N200	330 L/min (88.0 USgpm), "A" port flow 200 L/min (66.6 USgpm), "B" port flow
33C330N200	330 L/min (88.0 USgpm), "A" port flow 200 L/min (66.6 USgpm), "B" port flow
133C330N200	330 L/min (88.0 USgpm), "A" port flow 200 L/min (66.6 USgpm), "B" port flow
12C330N200	330 L/min (88.0 USgpm), "A" port flow 200 L/min (66.6 USgpm), "B" port flow

For KBDG5V-10 valves

2C310N550	310 L/min (82.6 USgpm), "A" port flow 550 L/min (145 USgpm), "B" port flow
2C550N310	550 L/min (145 USgpm), "A" port flow 310 L/min (82.6 USgpm), "B" port flow
33C310N550	310 L/min (82.6 USgpm), "A" port flow 550 L/min (145 USgpm), "B" port flow
33C550N310	550 L/min (145 USgpm), "A" port flow 310 L/min (82.6 USgpm), "B" port flow

Model Codes (cont.)

9	Pilot Supply	
	Models without integral, fixed pilot pressure reducer module	
	E	External pilot supply
	Blank	Internal pilot supply
Models with integral, fixed pilot pressure reducer module		
	X	Internal pilot supply
	EX	External pilot supply
For system pressures less than 200 bar (2900 psi) the pilot pressure reducing module is optional.		
For system pressures above 200 bar (2900 psi) the pilot pressure reducing module must be fitted.		

10	Pilot Drain	
	T	Internal pilot drain
	Blank	External pilot drain

11	Manual Override	
	Blank	Plain overrides
	H	Water-resistant overrides
	Z	No overrides

12	Electrical Command Option	
	1 -	+/- 10V control signal
	2 -	4-20 mA control signal

13	Electrical Connection	
	PC7 -	7 pin connector without plug supplied
	PE7 -	7 pin connector with plug supplied
	PH7 -	As PE7 but with pin "C" used for enable signal
	PR7 -	As PC7 but with pin "C" used for enable signal

14	Coil Identification	
	H -	24V

15	Design Number, 10 Series	
	Subject to change. Installation dimensions unaltered for design numbers 10 to 19 respectively. Design 20 only for KBDG5V-7	



Warning

Valves with integral amplifiers are supplied with or without the metal 7-pin plug. The Vickers plug, part no. 934939, must be correctly fitted to ensure that the EMC rating and IP67 rating are achieved. The plug retaining nut must be tightened to 2-2,5 Nm (1.5-2.0 lbf ft) to effect a proper seal.

Spool Data

Spool Types and Flow Ratings

Symmetric Spools

Flow ratings for flow through P-A-B-T at $\Delta p = 5$ bar (72 psi) per flow path, e.g. P-A, or B-T. For other pressure drop values see "Flow Gain" curves on pages 10 and 11.

SPOOL CODE	MAIN STAGE SPOOL SYMBOL	FLOW RATING
For KBDG5V-5 valves:		
2C90N	2C	90 L/min (24 USgpm)
33C80	33C	80 L/min (21 USgpm)
For KBDG5V-7 valves:		
2C230N	2C	230 L/min (61.3 USgpm)
33C230N	33C	230 L/min (61.3 USgpm)
336C185N	36C	185 L/min (49.3 USgpm)
For KBDG5V-8 valves:		
2C330N	2C	330 L/min (88 USgpm)
33C330N	33C	330 L/min (88 USgpm)
For KBDG5V-10 valves:		
2C550N	2C	550 L/min (145 USgpm)
7C550N	7C	550 L/min (145 USgpm)
12C550N	12C	550 L/min (145 USgpm)
33C550N	33C	550 L/min (145 USgpm)

Asymmetric Spools

Figure preceding metering type designator, "N" (e.g. 2C***N) is flow rating P-A, or A-T ("A" port flow); figure after "N" (N***) is flow rating P-B, or B-T ("B" port flow).

SPOOL CODE	MAIN STAGE SPOOL SYMBOL	FLOW RATING
For KBDG5V-5 valves:		
2C70N45	2C	70 L/min (18.6 USgpm), "A" port flow 45 L/min (12.0 USgpm), "B" port flow
33C60N40	33C	60 L/min (16.0 USgpm), "A" port flow 35 L/min (9.3 USgpm), "B" port flow
For KBDG5V-7-20 valves:		
2C230N140	2C	230 L/min (61.3 USgpm), "A" port flow 140 L/min (37.3 USgpm), "B" port flow
33C230N140	33C	230 L/min (61.3 USgpm), "A" port flow 140 L/min (37.3 USgpm), "B" port flow
133C230N140	133C	230 L/min (61.3 USgpm), "A" port flow 140 L/min (37.3 USgpm), "B" port flow
For KBDG5V-8 valves:		
2C330N200	2C	330 L/min (88.0 USgpm), "A" port flow 250 L/min (66.6 USgpm), "B" port flow
33C330N200	33C	330 L/min (88.0 USgpm), "A" port flow 250 L/min (66.6 USgpm), "B" port flow
133C330N200	133C	330 L/min (88.0 USgpm), "A" port flow 250 L/min (66.6 USgpm), "B" port flow
12C330N200	12C	330 L/min (88.0 USgpm), "A" port flow 250 L/min (66.6 USgpm), "B" port flow
For KBDG5V-10 valves:		
2C310N550	2C	310 L/min (82.6 USgpm), "A" port flow 550 L/min (145 USgpm), "B" port flow
2C550N310	2C	550 L/min (145 USgpm), "A" port flow 310 L/min (82.6 USgpm), "B" port flow
33C310N550	33C	310 L/min (82.6 USgpm), "A" port flow 550 L/min (145 USgpm), "B" port flow
33C550N310	33C	550 L/min (145 USgpm), "A" port flow 310 L/min (82.6 USgpm), "B" port flow

Functional Symbols

Spool Symbols

Simplified symbols including transient flow conditions (dotted line).

Spool type 2C

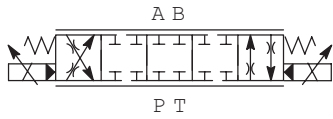

Spool type 7C

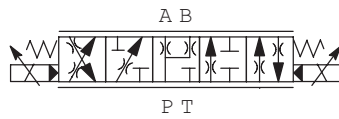

Spool type 12C

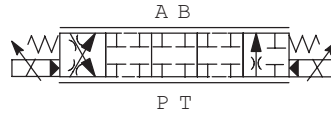

Spool type 33C

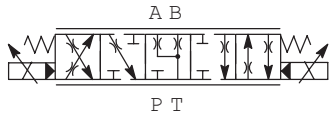

Spool type 36C

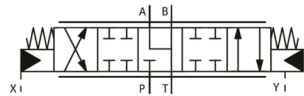

Spool type 133C
with typical regenerative circuit

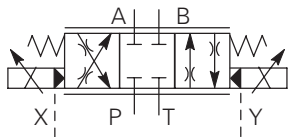
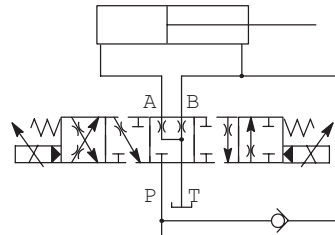

Simplified symbol
KBDG5V models
(Spool type "2" shown)

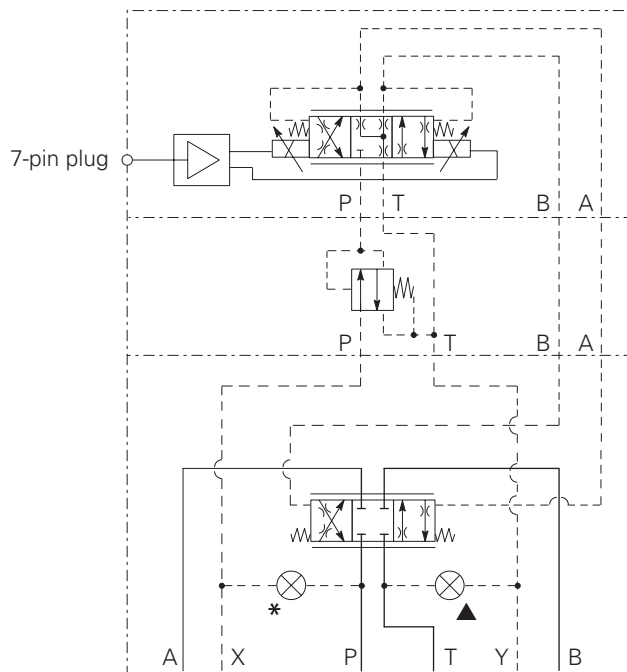

Pilot stage with integral
amplifier.

Pressure reducer module, see
"Model Code".

Main-stage.
Spool type "2C" shown.

Typical schematic symbol

* Internal plug shown, for external pilot supply (via port X). For internal pilot supply (from port P) plug is not fitted. Port X should be blocked at mounting interface, or otherwise plugged at subplate or manifold block. See "Model Code".

▲ Internal plug shown, for external pilot drain (via port Y). For internal pilot drain (via port T) plug is not fitted. Port Y should be blocked at mounting interface, or otherwise plugged at subplate or manifold block. See "Model Code".
See also "Pilot Drain Application" notes.

Operating Data

Data is typical with fluid at 36 cSt (168 SUS) and 50°C (122°F).

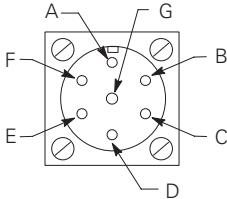
Power supply (24V)	(Model code 13 H)	24V DC (21V to 36V including 10% peak-to-peak ripple) maximum current - 1.2A
Command signal		
Voltage mode		0 to +10V DC, or 0 to -10V DC, or -10V to +10V DC
Input impedance		M1: 47 kΩ
Common mode voltage to pin D		18V (max)
Max differential voltage to pin E to pin B		4V
Current mode		4-20 mA
The content of row input impedance		100Ω
Command Signal (Current)		4-20 mA
Input impedance	(Model code 11 2)	100Ω
Valve enable signal:		
Enable		>9.0V (36V max)
Disable		<2.0V
Input impedance		36 kΩ
7-pin plug connector		Pin Description
		
View of pins of fixed half		A Power supply positive (+) B Power supply 0V and current command return C Valve enable (PH7 & PR7) D Command signal (+V or current in) E Command signal (-V or current GND) F Output monitor G Protective ground
Electromagnetic compatibility (EMC):		IEC 61326-2-1 (Electrical equipment for measurement, control and laboratory use) Conducted Emissions CISPR11 -2015-06 Ed 6.0/EN55011 - Class A, 150KHz - 30KHz Radiated Emissions CISPR11 -2015-06 Ed 6.0/EN55011 - Class A, 30MHz - 1GHz RF Continuous Conducted disturbances IEC 61000-4-6, 3Vrms Class A 150 KHz to 80MHz RF Electromagnetic Field, 80MHz to 1GHz, 10V/m; 1.4GHz to 2.7GHz, 3V/m; Meets Criterion A Surge: IEC 61000-4-5 • DC Power Port: +/- 1kV • Signal Control Port: +/-1kV Electrical Fast Transients IEC 61000-4-4, Class B • DC Power Port: +/- 1kV • Signal Control Port: +/-1kV Electrostatic discharges (ESO) IEC 61000-4-2 Class B • Air +/-8kV • Contact +/- 4kV
ROHS Compliance:		Complies with Restriction of Hazardous Substances (ROHS) Directive 2011/65/EU
Monitor signal (pin F)		0 to +5V (0.39 V/A)
Output impedance		10 kΩ
Reproducibility, valve-to-valve (at factory settings):		
Flow at 100% command signal		≤5%
Protection:		
Electrical		Reverse polarity protected
Environmental		IEC 529, Class IP67
Ambient air temperature range for full performance		0°C to 70°C (32°F to 158°F)
Oil temperature range for full performance		0°C to 70°C (32°F to 158°F)
Minimum temperature at which valves will work at reduced performance		-20°C (-4°F)
Storage temperature range		-25°C to +85°C (-13°F to +185°F)
Mass:		
Valves with integral pressure reducing module		
KBDG5V-5		9,8 kg (21.2 lb)
KBDG5V-7		12.3 kg (27.12 lb)
KBDG5V-8		20,6 kg (44.6 lb)
KBDG5V-10		54,9 kg (118.9 lb)
For models without reducing module, deduct 1,2 kg (2.6 lb)		
Ramp time		0-12 sec for full step input (0-100%)
Relative duty factor		Continuous rating (ED = 100%)
Hysteresis with flow through P-A-B-T		<8% of rated flow

Performance Characteristics

Data is typical with fluid at 36 cSt (168 SUS) and 50°C (122°F).

Minimum Pressure

KBDG5V-5/7/8

For full flow performance, pilot pressure ≥ 45 bar (650 psi).

KBDG5V-10

For full flow performance, pilot pressure ≥ 28 bar (405 psi).

i.e.

Pressure at port P for internal pilot supply.

or

Pressure at port X for external pilot supply.

Pilot Drain Application Notes

External pilot drain is the recommended configuration.

Internal pilot drain is possible where a stable "T" port pressure, not exceeding 8 bar (116 psi), can be guaranteed.

WARNING 

Any pressure surges at the "T" port (drain) will cause the main spool to move and change the valve output. This possibility is eliminated by the use of an external drain.

Maximum Pressures, bar (psi)

For models without integral pilot pressure reducer

MODEL	PILOT PRESSURE SOURCE	MODEL CODE 7	PORTS P, A, B	T	X	Y †
KBDG5V-5	External	E	315 (4500)	210 (3000)	200 (2900)	8 (116)
	Internal	Omit	200§ (2900)	210 (3000)	▪	8 (116)
KBDG5V-7/8	External	E	350 (5000)	350 (5000)	200 (2900)	8 (116)
	Internal	Omit	200§ (2900)	350 (5000)	▪	8 (116)
KBDG5V-10	External	E	350 (5000)	350 (5000)	40 (580)	8 (116)
	Internal	Omit	40 (580)	350♦ (5000)	▪	8 (116)

For models with integral pilot pressure reducer

KBDG5V-5	External	EX	315 (4500)	210 (3000)	315 (4500)	8 (116)
	Internal	X	315 (4500)	210 (3000)	▪	8 (116)
KBDG5V-7/8	External	EX	350 (5000)	350♣ (5000)	315 (4500)	8 (116)
	Internal	X	350 (5000)	350♣ (5000)	▪	8 (116)
KBDG5V-10	External	EX	350 (5000)	350♦ (5000)	315 (4500)	8 (116)
	Internal	X	350 (5000)	350♦ (5000)	▪	8 (116)

- When using internal pilot pressure, port X should be plugged at the subplate or manifold face (e.g. manifold not drilled for connection to port X).
- § The maximum pressure for ports A and B is: 315 bar (4500 psi) for size 5; 350 bar (5000 psi) for sizes 7 and 8.
- † See "Pilot Drain Application" note.
- ♦ Pilot must be externally drained, otherwise "Y" port pressure applies.
- ♣ Pilot must be externally drained, otherwise "T" port pressure limited to 210 bar (3000 psi).

Power Capacity Envelopes

Flow through P-A-B-T or P-B-A-T

Power Capacity
Looped Flow

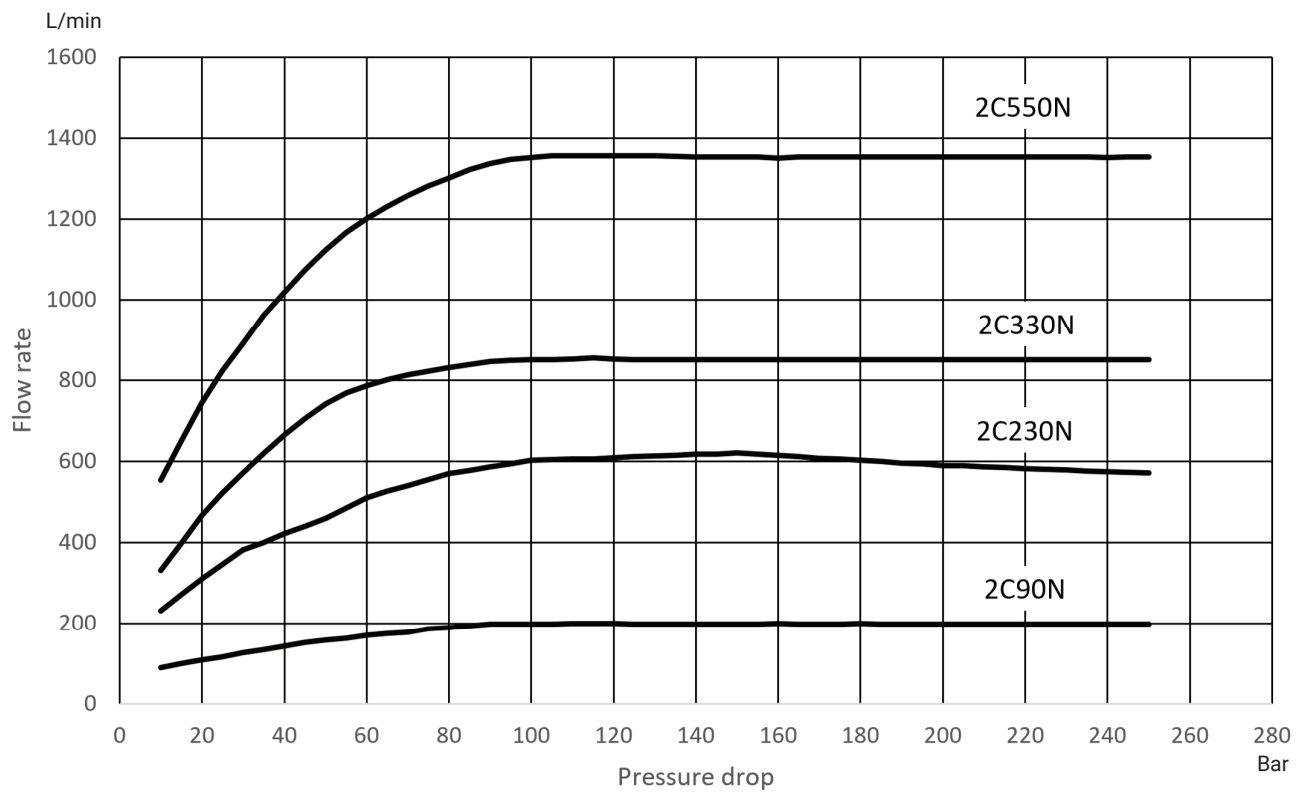
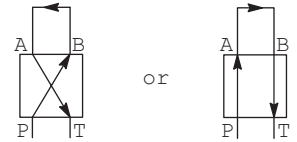

Flow Characteristics

Flow gain curves at stated values of total valve pressure drop, for flow P-A-B-T, or P-B-A-T.

Symmetric Spools

KBDG5V-5-2C90N

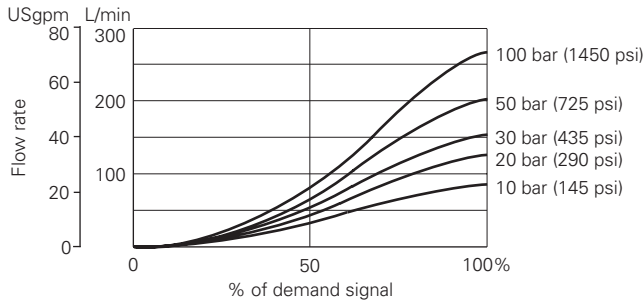

KBDG5V-5-33C80N

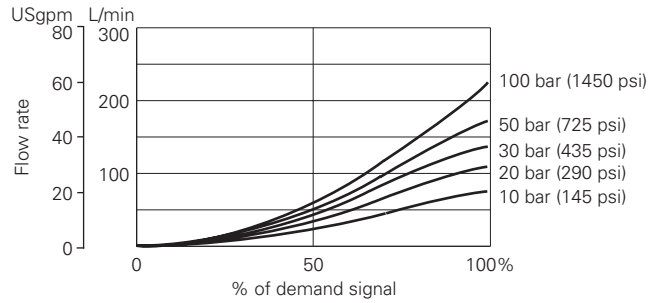

KBDG5V-7-2C230N

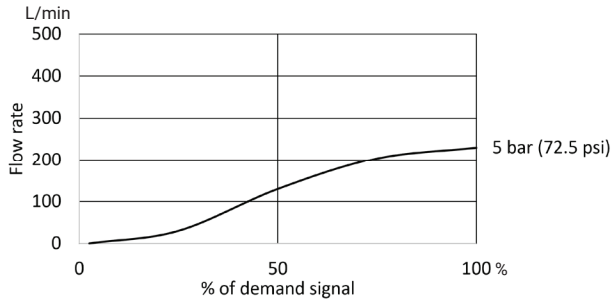

KBDG5V-7-33C230N

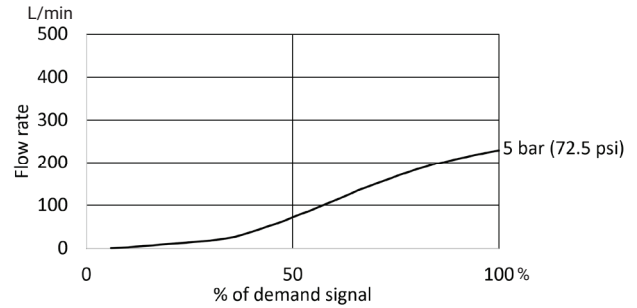

KBDG5V-8-2C330N

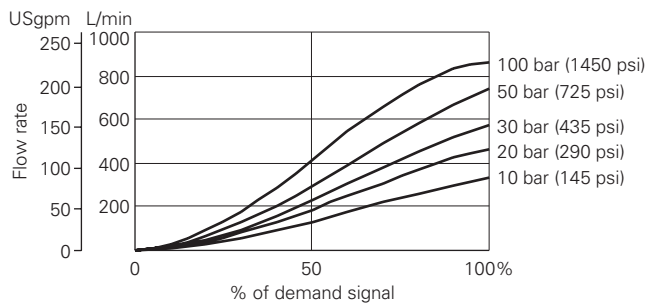

KBDG5V-8-33C330N

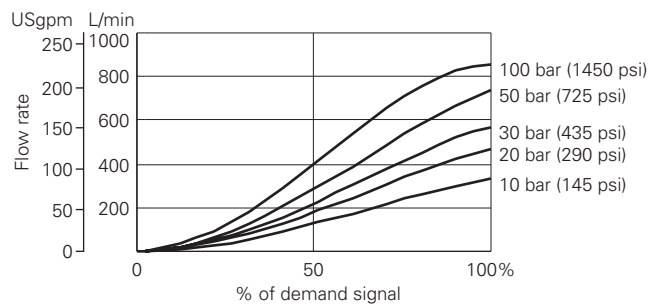

Flow Characteristics (continued)

Flow gain curves at 10 bar (145 psi) valve pressure drop, for flow P-A-B-T, or P-B-A-T.

KBDG5V-10-2C550N

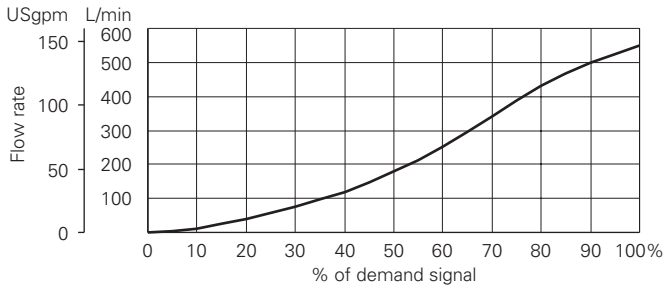

KBDG5V-10-7C550N KBDG5V-10-12C550N

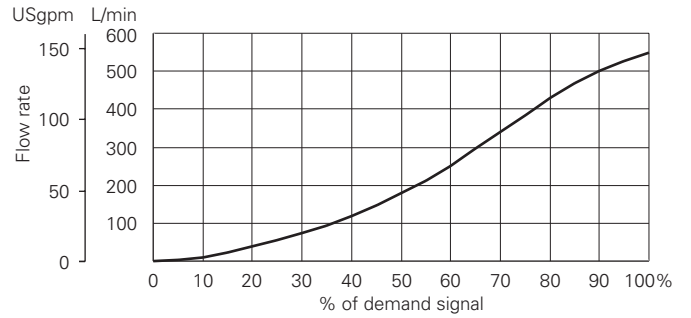

KBDG5V-10-33C550N

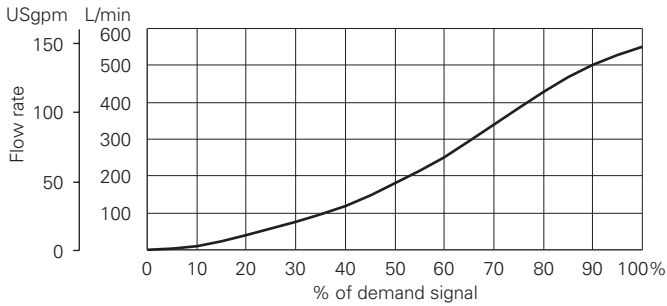

Asymmetric Spools

At 5 bar (72 psi) valve pressure drop

KBDG5V-5 2C70N45

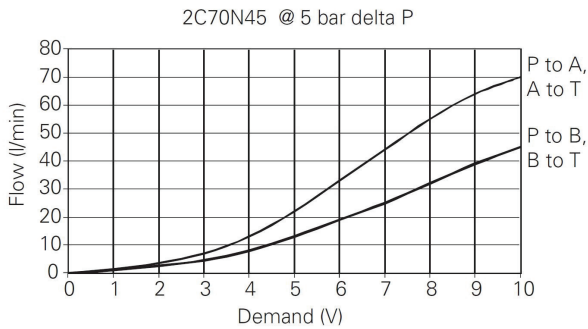

KBDG5V-5 33C60N35

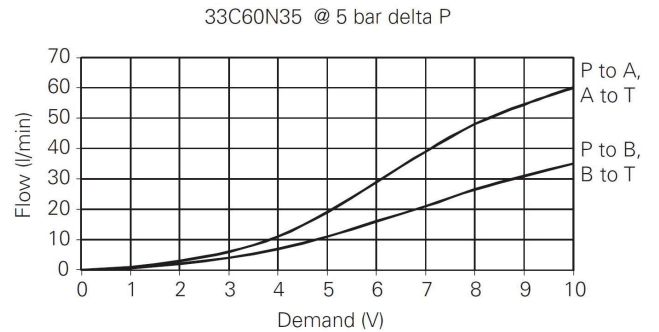

KBDG5V-7 33C230N140

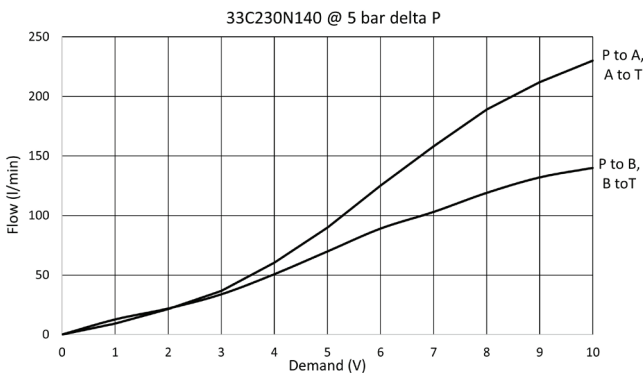

KBDG5V-8 2C330N200

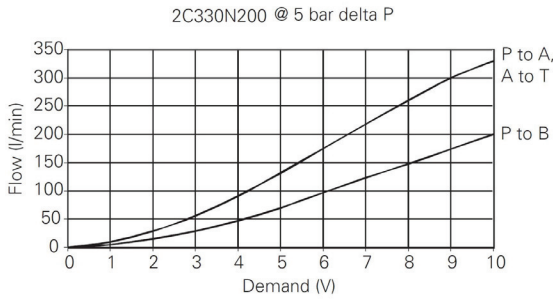

KBDG5V-8 33C330N200

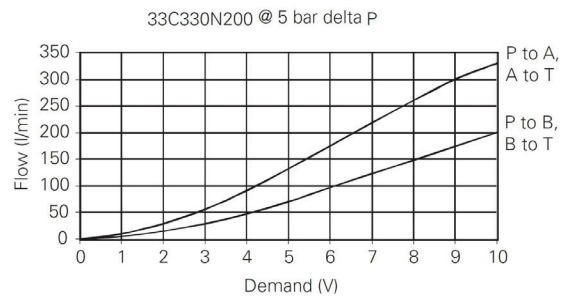

KBDG5V-8 133C330N200

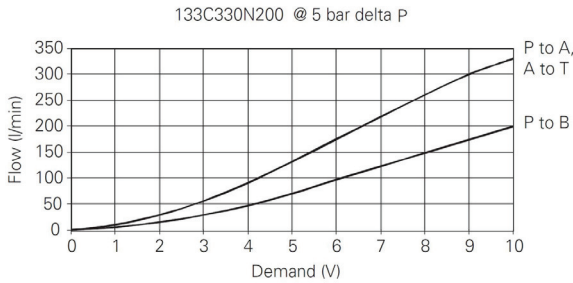

KBDG5V-8 12C330N200

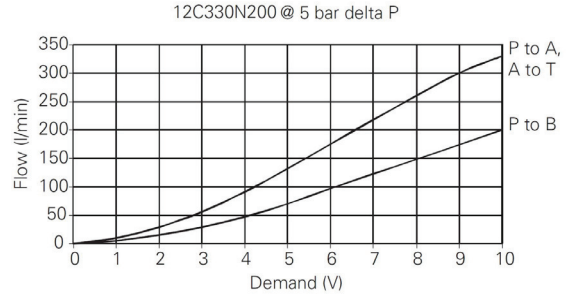

KBDG5V-10 2C550N310

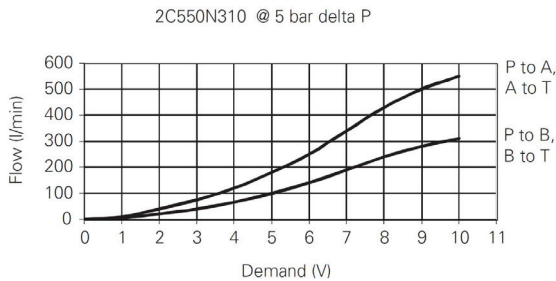

KBDG5V-10 33C550N310

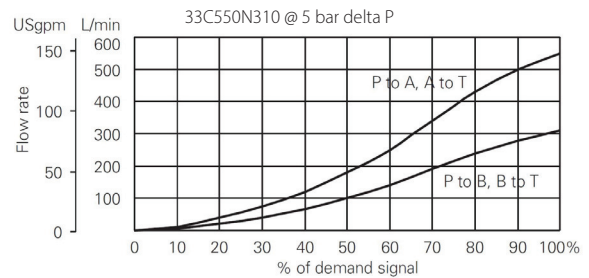

Step Response (Typical)

Test conditions:

No pressure reducer module

Flow P-A-B-T

Total valve $\Delta p = 10$ bar
(145 psi)

External pilot pressure = 50 bar
(725 psi)

“Response” = Time, from step response signal, until output reaches 90% of step change value

INPUT SIGNAL STEP CHANGE

INPUT SIGNAL STEP CHANGE	SPOOL RESPONSE TIMES (ms)			
	KBDG5V-5	KBDG5V-7	KBDG5V-8	KBDG5V-10
0 to 100%	42	65	85	110
100% to 0	33	45	55	110
10% to 90%	43	40	75	100
90% to 10%	40	60	54	100
25% to 75%	34	55	70	95
75% to 25%	30	45	45	95
90% to 90%	78	110	144	200

Pilot flow required to achieve above response times:

	KBDG5V-5	KBDG5V-7	KBDG5V-8	KBDG5V-10
	3,8 L/min	5,0 L/min	6,2 L/min	23,0 L/min
	(0.98 USgpm)	(1.3 USgpm)	(1.6 USgpm)	(5.96 USgpm)

Installation Dimensions

KBDG5V Models with "EX" or "X"

(With integral pilot pressure reducer)
The illustration is correct for KBDG5V-8 valves
Dimensions are shown in mm (inches)

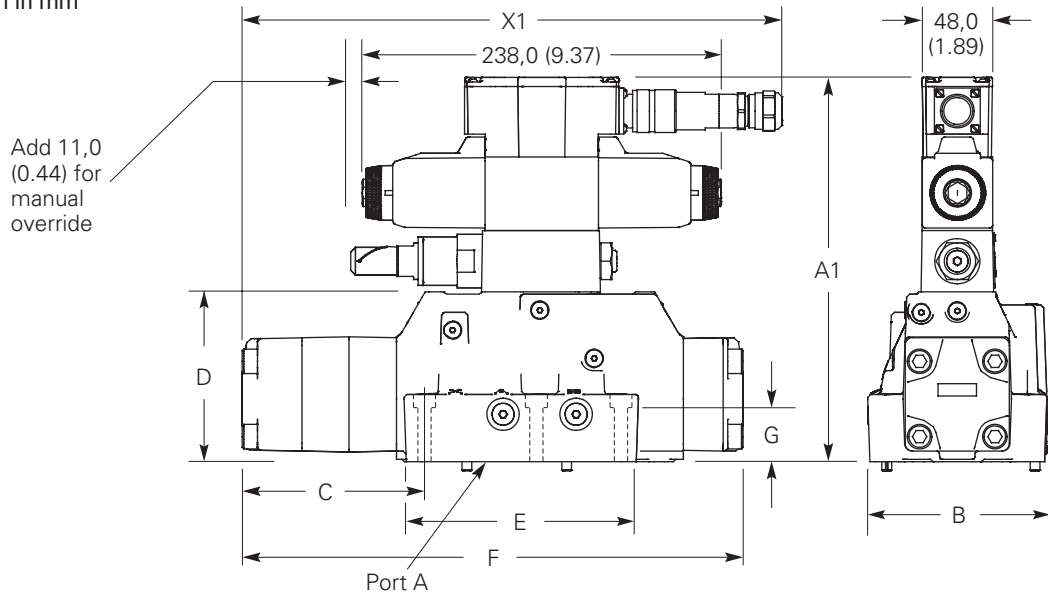

KBDG5V Models with "E" or No Symbol

(Without integral pilot pressure reducer)

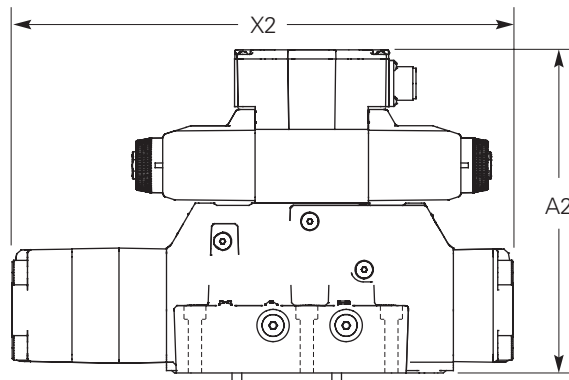

MODEL	A1	A2	B	C	D	E	F	G	X1s	X2s
KBDG5V-5	233,6 (9.20)	187,6 (7.39)	70,4 (2.77)	94,4 (3.72)	87,3 (3.4)	98,0 (3.86)	217,0 (8.54)	30,0 (1.18)	277,0 (10.9)	238,0 (9.37)
KBDG5V-7	235,1 (9.26)	195,1 (7.68)	92 (3.62)	123,3 (4.85)	95 (3.74)	121,4 (4.78)	269 (10.59)	33 (1.3)	310,8 (12.23)	269 (10.59)
KBDG5V-8	257,3 (10.13)	211,3 (8.32)	117,0 (4.60)	117,3 (4.62)	111,0 (4.37)	175,5 (6.91)	327,0 (12.87)	42,5 (1.67)	352,0 (13.86)	327,0 (12.87)
KBDG5V-10	339,8 (13.38)	293,8 (11.57)	196,8 (7.75)	194,3 (7.65)	193,5 (7.62)	226,8 (8.93)	516,9 (20.35)	35,0 (1.38)	516,9 (20.35)	516,9 (20.35)

▲ Overall installed length of KBD valves is X1 with connector fitted, and X2 without.

Pilot Supply and Drain Plugs

KBDG5V-5 models
Viewed from port B end of main-stage

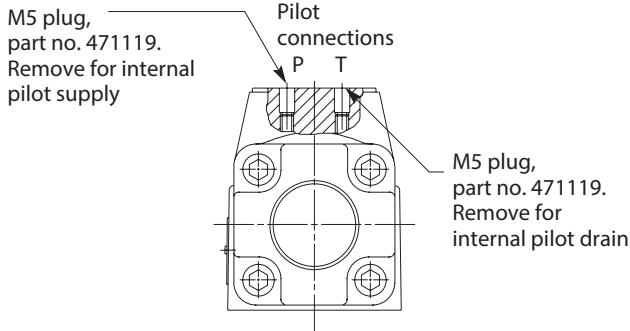

KBDG5V-7 Models
Viewed from port A end of main stage

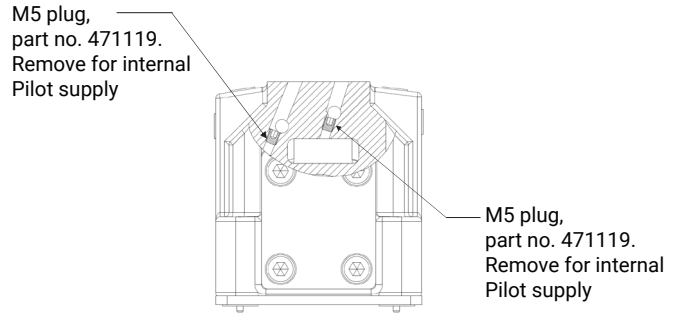

* Internal plug shown, for external pilot supply (via port X). For internal pilot supply (from port P) plug is not fitted. Port X should be blocked at mounting interface, or otherwise plugged at subplate of manifold block. See "Model Code".

KBDG5V-8 models
Section through port P of main-stage

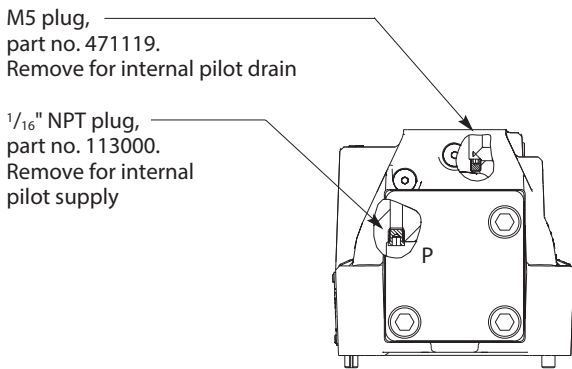

KBDG5V-10 models

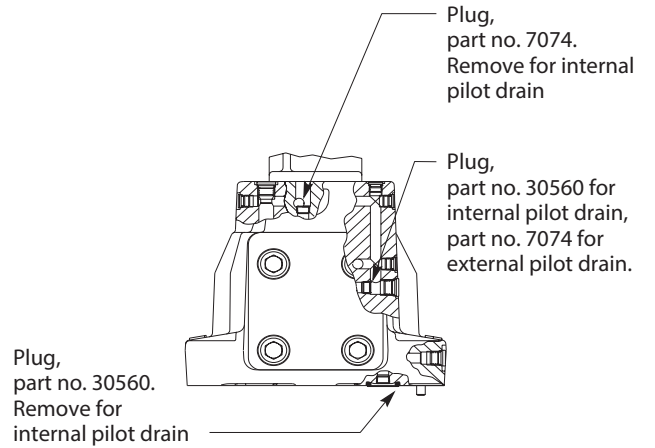

Views on
Mounting Faces

All O-seals supplied

KBDG5V-5

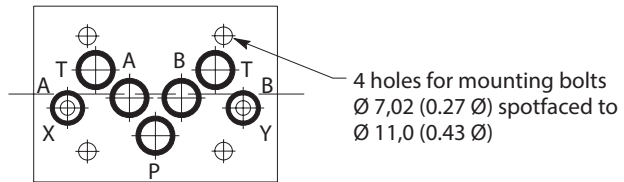

KBDG5V-7

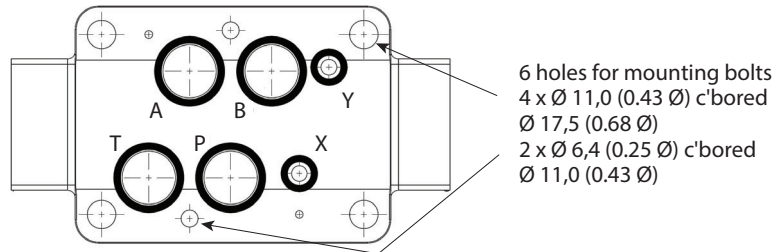

KBDG5V-8

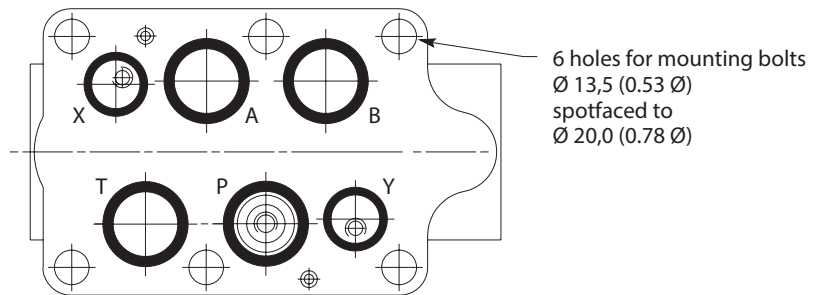

KBDG5V-10

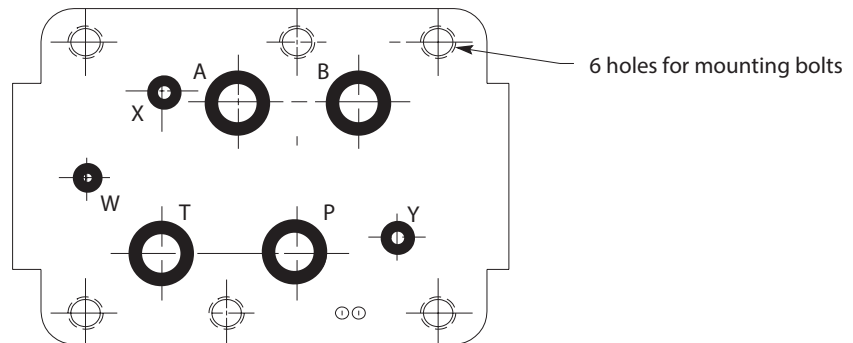

Block Diagram KBDG5V-*

COMMAND SIGNALS AND OUTPUTS

7-pin plug			Flow direction	
Command = Volts ($\pm 10V$)	Pin D	Pin E	P to A	
	Positive	0V		
	0V	Negative		
	$V_D - V_E = \text{Positive}$		P to B	
	Negative	0V		
0V	Positive			
$V_D - V_E = \text{Negative}$				

Command =	Pin D	Pin E	Pin B	Flow direction
Current (4-20 mA)	More than 12 mA	Current GND	Current return	P to A
	Less than 12 mA	Current GND	Current return	P to B

Wiring

Connections must be made via the 7-pin plug mounted on the amplifier. See this leaflet and Installation Wiring Practices for Vickers™ Electronic Products leaflet 2468. Recommended cable sizes are:

Power Cables

For 24V supply:
 0,75 mm² (18 AWG) up to 20m (65 ft)
 1,00 mm² (16 AWG) up to 40m (130 ft)

Signal Cables

0,50 mm² (20 AWG)

Screen (Shield)

A suitable cable would have 7 cores, a separate screen for the signal wires and an overall screen. Cable outside diameter 8,0-10,5 mm (0.31- 0.41 inches). See connection diagrams on next page.

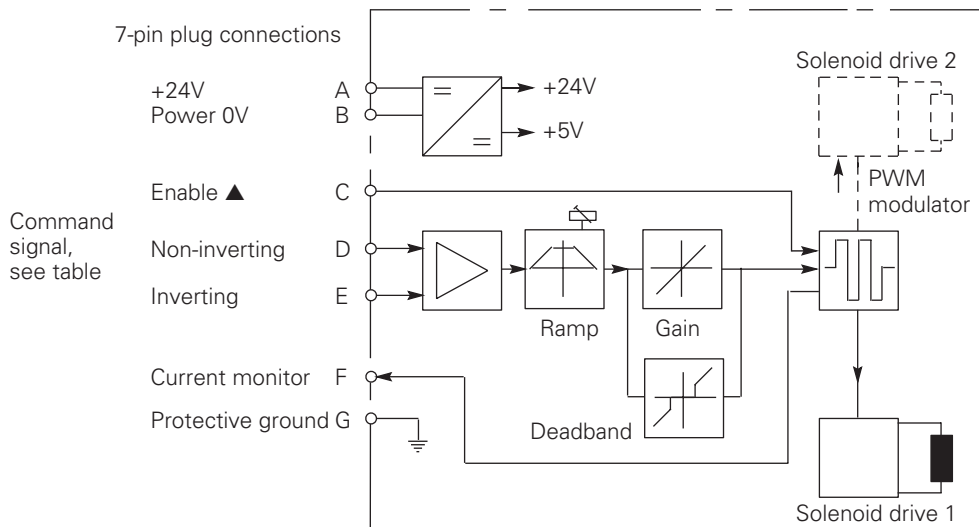

▲ In valves with PH7 or PR7 type electrical connection.



Warning

All power must be switched off before connecting or disconnecting any plugs.

Electrical Information

Voltage input (M1) wiring

Spool position monitor voltage (pin F) will be referenced to the KB valve local ground.

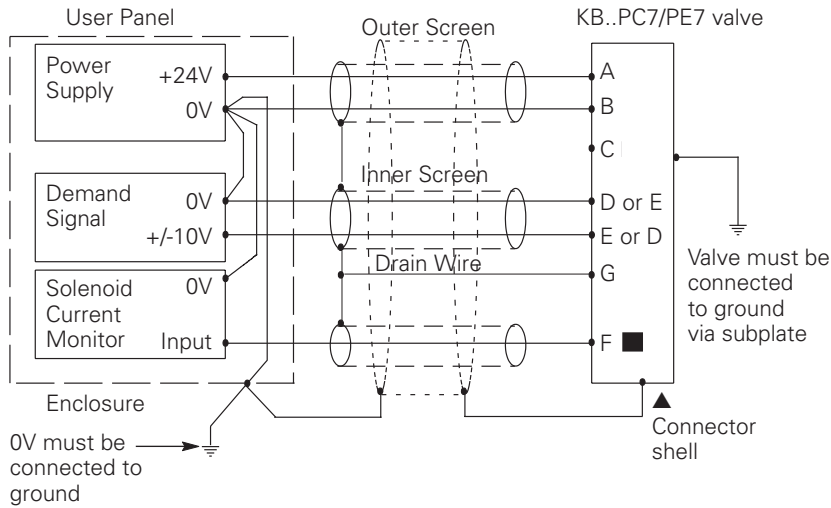

Wiring Connections for Valves with “Enable” Feature

▲ Note:

In applications where the valve must conform to European RFI/EMC regulations, the outer screen (shield) must be connected to the outer shell of the 7 pin connector, and the valve body must be fastened to the earth ground. Proper earth grounding practices must be observed in this case, as any differences in command source and valve ground potentials will result in a screen (shield) ground loop.

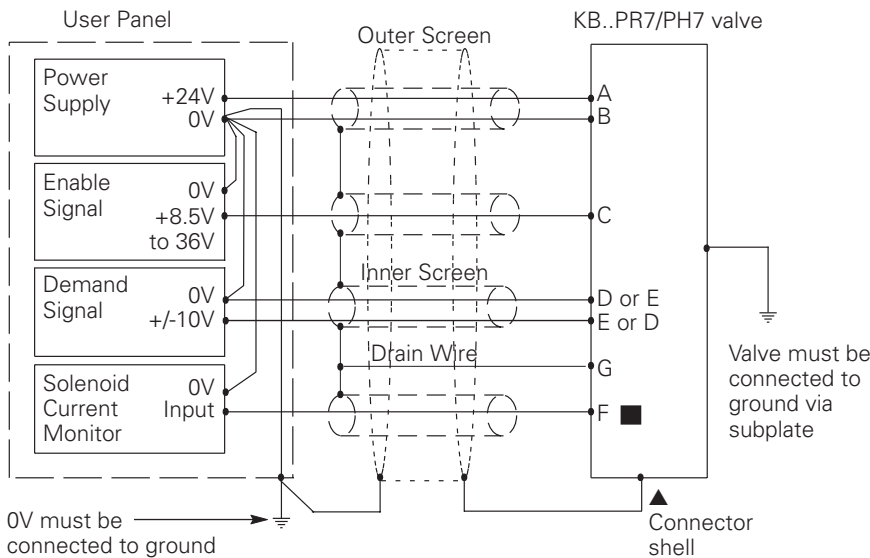

Electrical Information

Current input (M2) wiring

Spool position monitor voltage (pin F) will be referenced to the KB valve local ground.

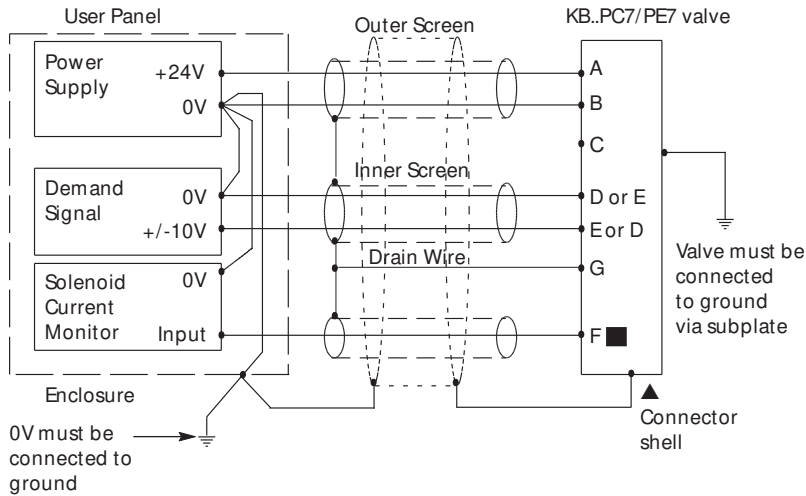

Warning

Electromagnetic Compatibility (EMC) It is necessary to ensure that the valve is wired up as above. For effective protection the user electrical cabinet, the valve subplate or manifold and the cable screens should be connected to efficient ground points. The metal 7 pin connector part no. 934939 should be used for the integral amplifier. In all cases both valve and cable should be kept as far away as possible from any sources of electromagnetic radiation such as cables carrying heavy current, relays and certain kinds of portable radio transmitters, etc. Difficult environments could mean that extra screening may be necessary to avoid the interference. It is important to connect the 0V lines as shown above. The multi-core cable should have at least two screens to separate the demand signal and monitor output from the power lines. The enable line to pin C should be outside the screen which contains the demand signal cables.

Wiring connections for M2 valves with enable feature

▲ Note:

In applications where the valve must conform to European RFI/EMC regulations, the outer screen (shield) must be connected to the outer shell of the 7 pin connector, and the valve body must be fastened to the earth ground. Proper earth grounding practices must be observed in this case, as any differences in command source and valve ground potentials will result in a screen (shield) ground loop.

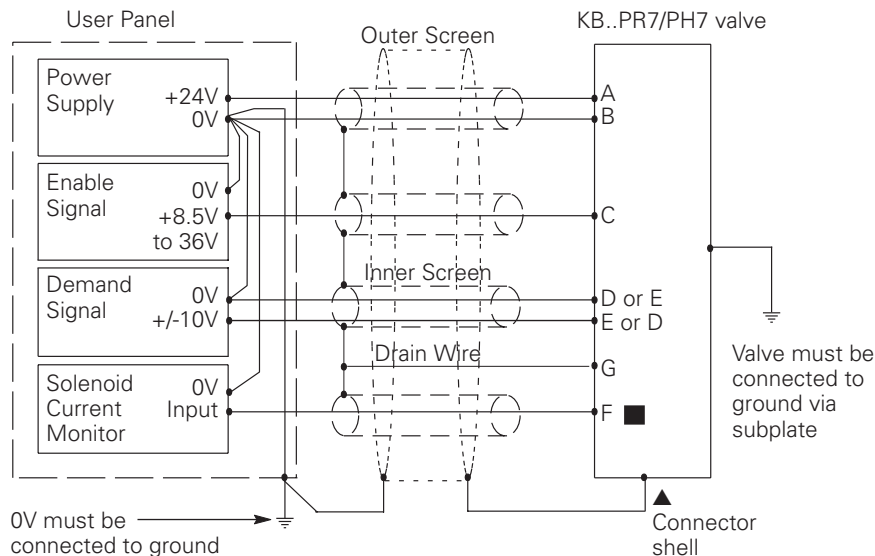

Application Data

Fluid Cleanliness

Proper fluid condition is essential for long and satisfactory life of hydraulic components and systems. Hydraulic fluid must have the correct balance of cleanliness, materials and additives for protection against wear of components, elevated viscosity and inclusion of air.

Recommendations on contamination control methods and the selection of products to control fluid condition are included in publication 9132 or 561, "Guide to Systemic Contamination Control". The book also includes information on the concept of "ProActive Maintenance". The following recommendations are based on ISO cleanliness levels at 2 µm, 5 µm and 15 µm.

For products in this catalog the recommended levels are:

0 to 70 bar (1000 psi)..18/16/13
70+ bar (1000+ psi)...17/15/12

Vickers™ products, as any components, will operate with apparent satisfaction in fluids with higher cleanliness codes than those described. Other manufacturers will often recommend levels above those specified.

Experience has shown, however, that life of any hydraulic components is shortened in fluids with higher cleanliness codes than those listed above. These codes have

been proven to provide a long trouble-free service life for the products shown, regardless of the manufacturer.

Hydraulic Fluids

Materials and seals used in these valves are compatible with antiwear hydraulic oils, and with non-alkyl-based phosphate esters.

The extreme operating viscosity range is 500 to 13 cSt (2270 to 70 SUS) but the recommended running range is 54 to 13 cSt (245 to 70 SUS).

Installation

The proportional valves in this catalog can be mounted in any attitude, but it may be necessary in certain demanding applications, to ensure that the solenoids are kept full of hydraulic fluid. Good installation practice dictates that the tank port and any drain port are piped so as to keep the valves full of fluid once the system start-up has been completed.

Mounting Bolt Kits

For KBDG5V-5
BK02-156493M (metric)
BK590720 (inch)

For KBDG5V-7
BKDG7M (metric)
BK590724 (inch)

For KBDG5V-8
BKDG8-655M (metric)
BKDG06-635 (inch)

For KBDG5V-10
BKDG10636M (metric)
BKDG10636 (inch)

If not using recommended Vickers™ bolt kits, bolts used should be to ISO 898, 12.9 or better.

For further technical information about fluids see "Technical Information" leaflet B-920 or I-286S.

Mounting Bolt Torques

Recommended torques with threads lubricated

For KBDG5V-5
M6 or 1/4"-20 UNC bolts:
To 210 bar (3000 psi) 14 Nm (10.3 lbf ft)
To 310 bar (4500 psi) 20 Nm (14.75 lbf ft)

For KBDG5V-7
M10 or 3/8"-16 UNC bolts:
49 to 59 Nm (36 to 43 lbf ft) plus
M6 or 1/4"-20 UNC bolts
9 to 14 Nm (6.6 to 10.3 lbf ft)

For KBDG5V-8
M12 or 1/2"-13 UNC bolts
103 to 127 Nm (76 to 93 lbf ft)

For KBDG5V-10
M20 or 3/4"-10 UNC-2B bolts
185-220 Nm (250-300 lbf ft)

Seal Kits (Mainstage Only)

KBDG5V-5.....565143
KBDG5V-7.....6048718-001
KBDG5V-8.....02-352520
KBDG5V-10.....02-329888

Plugs

7-pin plug (metal) 934939
(Metal plug must be used for full EMC protection)

Note: An alternative metal connector which gives EMC protection but not IP67 rating is available from ITT-Cannon, part number CA06-COM-E-14S-A7-P.

Service Information

The products from this range are preset at the factory for optimum performance; disassembling critical items would destroy these settings. It is recommended that if any mechanical or electronic repair is necessary, valves should be returned to the nearest Danfoss Hydraulics repair center. The products will be refurbished as necessary and retested to specification before return.

Field repair is restricted to the replacement of the seals.

ENGINEERING
TOMORROW

Danfoss

Danfoss
14615 Lone Oak Road
Eden Prairie, MN 55344-2287
USA
Tel: (+1) 952 937-9800
Fax: (+1) 952 974-7722

Danfoss
20 Rosamond Road
Footscray
Victoria 3011
Australia
Tel: (+61) 3 9319 8222
Fax: (+61) 3 9318 5714

Danfoss
46 New Lane, Havant
Hampshire PO9 2NB
England
Tel: (+44) 23 9248 6451
Fax: (+44) 23 9248 7110

VICKERS
by Danfoss

© 2022 Danfoss Corporation
All Rights Reserved
Printed in USA
Document No. AF434458717508en-000101
November 2022