

# Compressor Air Brake Systems

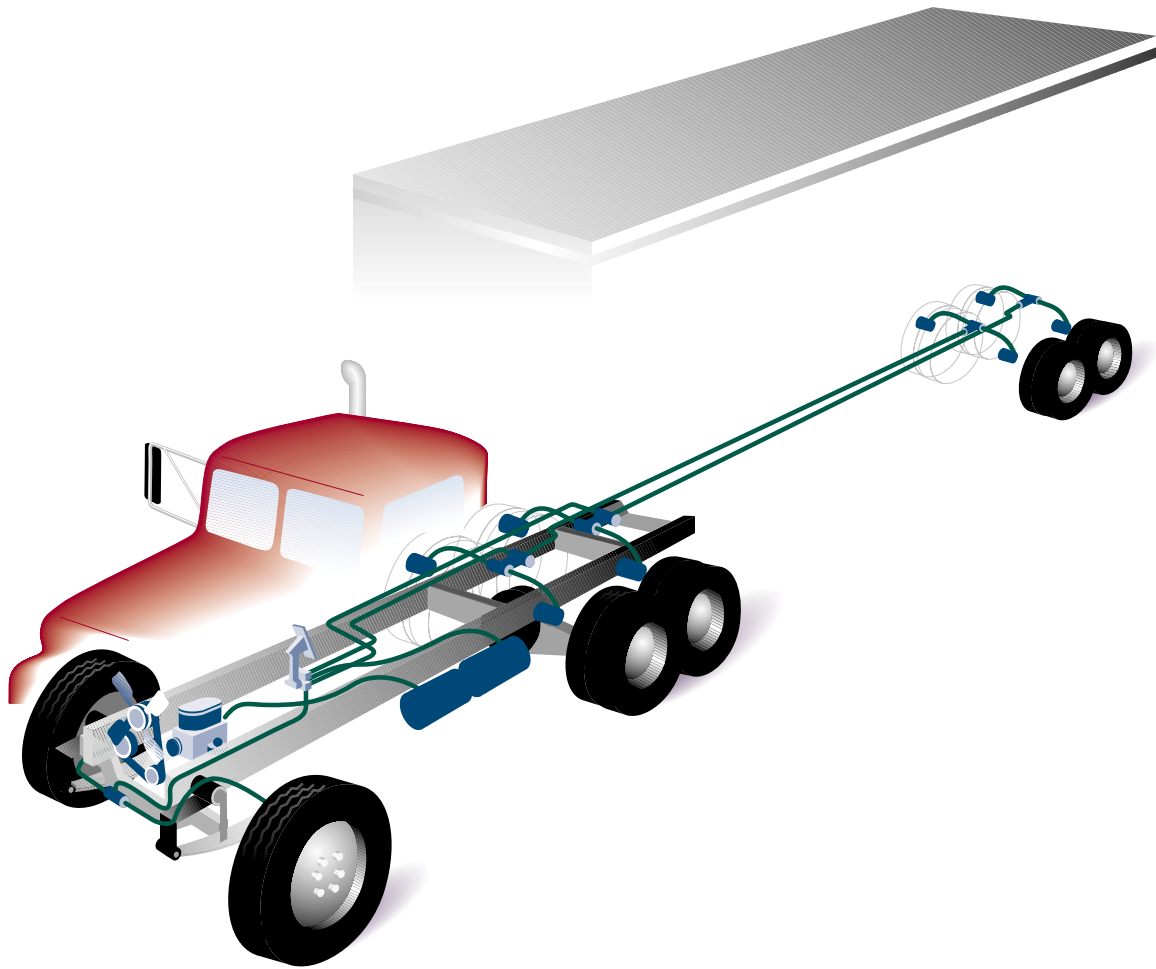

---

## 2570 Air Brake Hose

### Features:

- Synthetic rubber tube and cover
- Double textile braid reinforcement
- Crimp or screw-together reusable fittings

### Benefits:

- Proven heavy-duty elastomers
- Superior performance; extended service life
- Wide selection of fitting designs

# Aeroquip 2570

## Extended Service Air Brake Hose



### Specifications and Performance:

(SAE J1402 FMVSS 106 Type All)

Part Number	Hose I.D. (mm/inch)	Hose O.D. (mm/inch)	Max. Oper. Press. (Bar/psi)	Min. Burst Press. (Bar/psi)	Min. Bend Radius (mm/inch)
2570-6	9.5/.38	19.1/.75	15.5/225	62.0/900	44.5/1.75
2570-8	12.7/.50	22.4/.88	15.5/225	62.0/900	50.8/2.00
2570-10	15.9/.63	26.9/1.06	15.5/225	62.0/900	57.2/2.25

#### Operating Temperature Range:

- -40°F to +212°F  
(-40°C to +100°C)

#### Applications:

- Tractor to trailer lines
- Frame to axle chamber lines
- Tractor service lines



**Eaton Aeroquip**  
Industrial Division  
3000 Strayer Road, P.O. Box 631  
Maumee, Ohio 43537-0631  
419/867-2600, Fax: 419/867-2629  
[www.aeroquip.com](http://www.aeroquip.com)

