

# Line Filter MCC 107 Installation Instructions

Line Filters of the type MCC 107 combine a harmonic filter and an EMC filter. The line filters improve performance of the line current to the VLT® Micro Drive FC 51. The three different Line Filter frame sizes correspond to the M1, M2 and M3 Micro Drives.

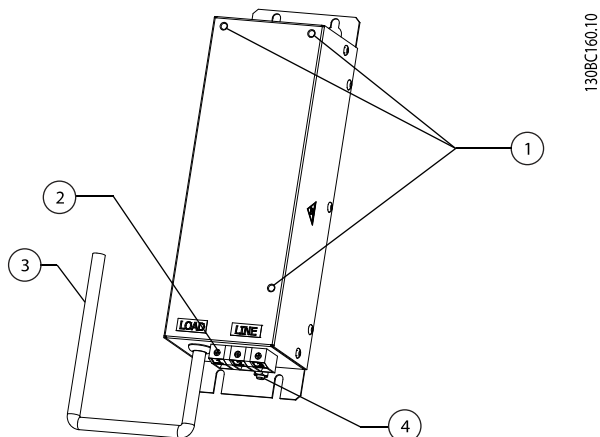

Illustration 1.1 Line Filter MCC 107 with Micro Drive FC 51

1	Mounting holes for frequency converter
2	Input terminal
3	Output line
4	Protective earth (PE)

Table 1.1

## CAUTION

### Hot surfaces

Risk of high surface temperatures.

- Do NOT touch the Line Filter during operation or wear protective gloves

## WARNING

### High voltage

Risk of electric shock.

- Never carry out maintenance work on the Line Filter during operation. Wait at least 4 minutes after the equipment has been disconnected from the frequency converter before touching any potentially live parts.

## NOTE

- Never repair a defective filter

## Mounting

There are two options for mounting the Line Filter correctly:

### 1. Front mounting

- Mount the filter in a vertical position with the terminals at the bottom.
- Mount the frequency converter on the front of the Line Filter using 3 M4 bolts.

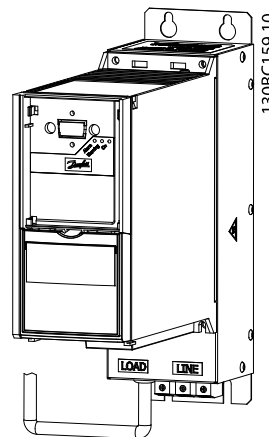

Illustration 1.2 Line Filter with frequency converter

- Ensure metal-to-metal contact between filter and frequency converter.

## NOTE

Metal-to-metal contact improves EMC performance and enables the baseplate of the frequency converter to function as heatsink for the Line Filter

2. Side mounting

- Mount the filter side-by-side with the frequency converter. There is no requirement for spacing between filter and frequency converter.
- Mount the back of the Line Filter to a cooling surface, such as a metal wall. Alternatively, derate the Line Filter by one size: For example use a 0.75 kW Line Filter with a 0.37 kW Micro Drive.

**CAUTION**

High temperatures

Risk of fire or device damage

- Do not mount the Line Filter in close proximity to other heating elements or heat-sensitive material (such as wood).

Wiring

**WARNING**

Risk of electrical shock due to high leakage currents

- Do not power up the Line Filter before it is connected to protective earth (PE)
1. Connect Line Filter to protective earth (PE). Use a cabinet mounting panel or similar to achieve optimum earthing conditions.
  2. Connect input terminal to mains power (cable not supplied)
  3. Connect output cable to the input terminals of the frequency converter
  4. Ensure solid electrical contact between Line Filter and frequency converter (high frequency earthing)

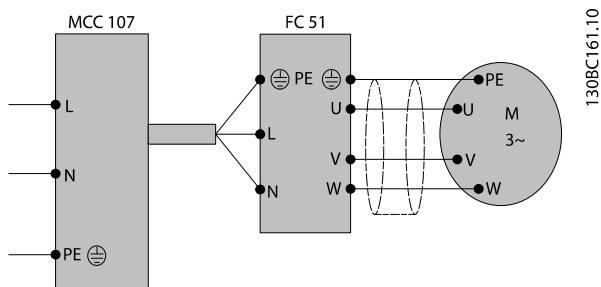

Illustration 1.3 Line 1

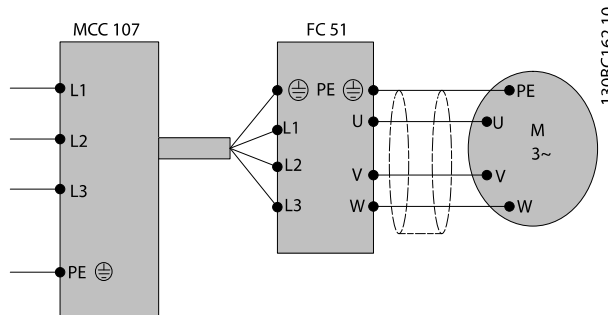

Illustration 1.4 Line 2

NOTE

- Reduce common mode interferences by establishing a low impedance current path to the VLT® Micro Drive.
- To ensure optimum EMC performance, use a De-Coupling plate kit (ordering numbers 132B0106 or 132B0107)

For voltage rating, wire size and fuse selection, see the VLT® Micro Drive Quick Guide at our technical literature website <http://www.danfoss.com/BusinessAreas/DrivesSolutions/Documentations/Technical+Documentation.htm>

## Dimensions

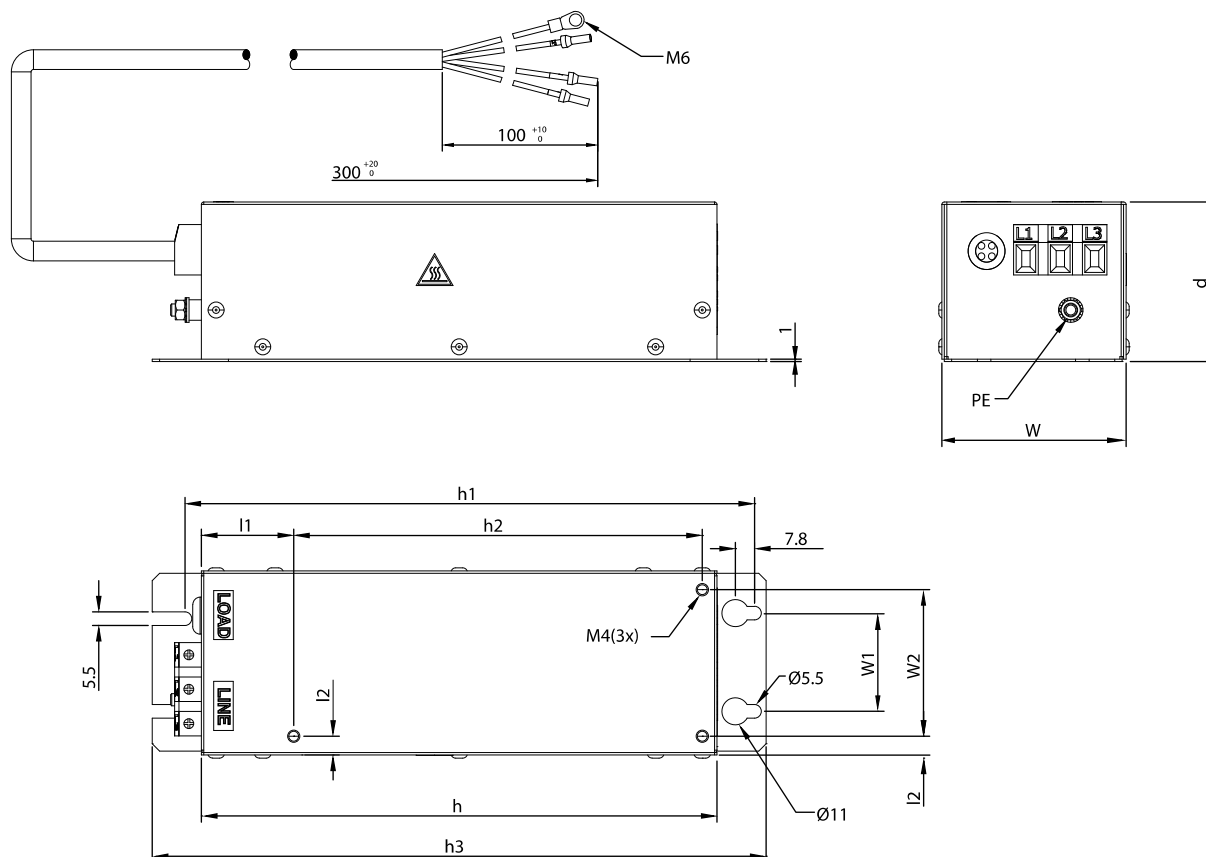

130BC163.10

Illustration 1.5

Frame /	M1	M2	M3	Unit/
w	70	75	90	mm
d	55	65	69	mm
h	190	210	300	mm
h3	230	250	340	mm
w1	40	40	55,6	mm
h1	213	233	323	mm
w2	55	59	69	mm
h2	140	166,5	226	mm
l1	45	38,5	68	mm
l2	7,6	8	9,3	mm
PE	M6	M6	M6	metric
Weight	2	3	5	kg

Table 1.2