

Installation guide – Spare parts and accessories

Repair kit | Code number 148B6060

SVA-S/L, SVA-ST/LT sizes 6 to 10, REG-SA/SB, REG size 10

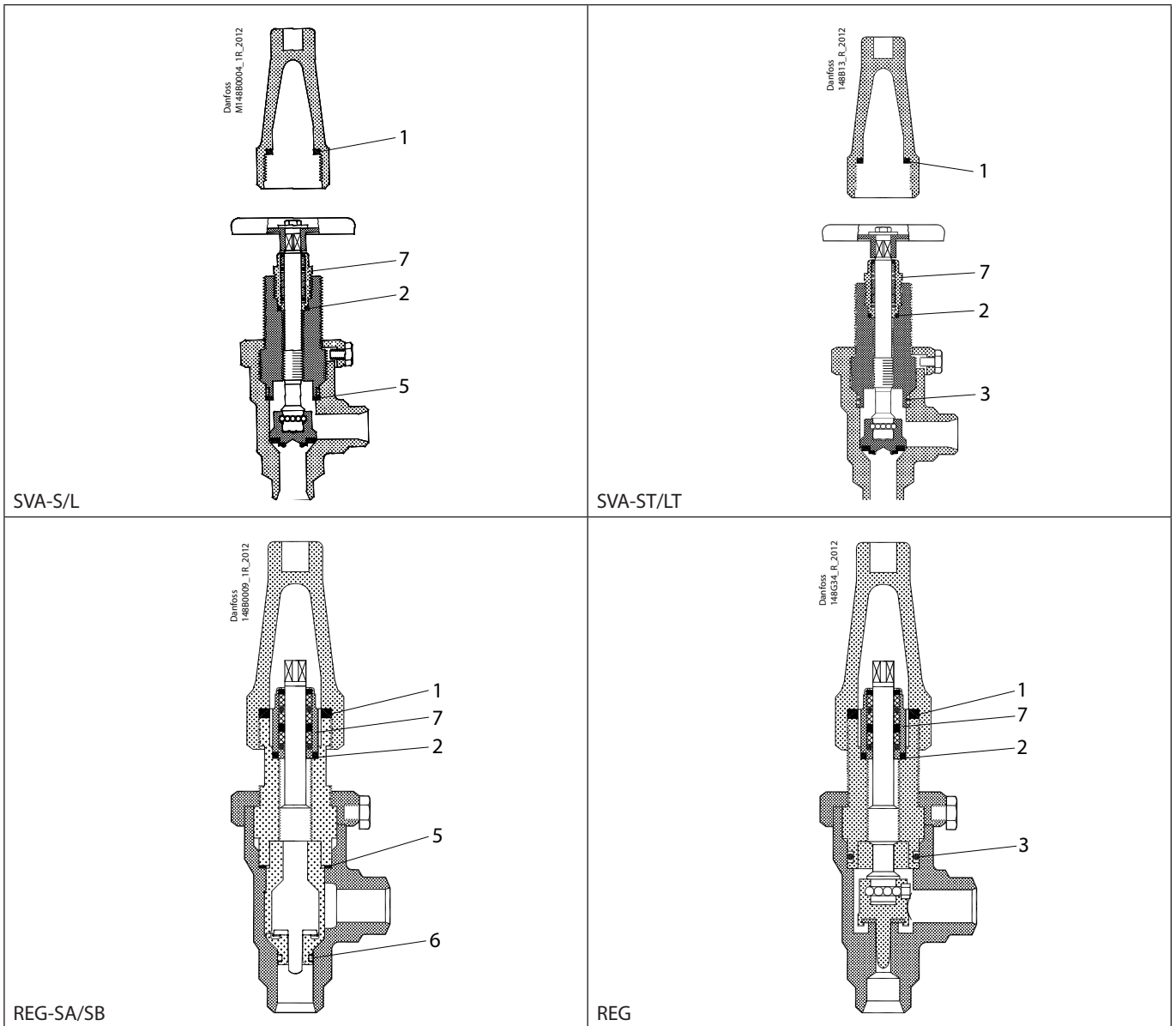

<p>1</p> <p> = Nylon</p> <p>Total no. = 1</p>	<p>2</p> <p> = Alu.</p> <p>Total no. = 1</p>	<p>3</p> <p>Total no. = 1</p>	<p>5</p> <p> = Alu.</p> <p>Total no. = 1</p>	<p>6</p> <p>Total no. = 1</p>
<p>7</p> <p>Total no. = 1</p>				

NOTE: When replacing the packing gland (pos. 7) in SVA-ST, SVA-S/L, SVA-HS or REG the aluminium gasket (pos. 2) is needed.