



Fan Drive HIC Technical Information

Quick Reference

Fan Drive HICs	Model No.	Description	Flow	Pressure	Page
	RFDE-40-000	Fan Drive HIC with Reversing Control	10 - 40 l/min [2.6 - 10.5 US gal/min]	210 bar [3000 psi]	FD - 5
	RFDE-80-000		20 - 80 l/min [5.3 - 21.1 US gal/min]	210 bar [3000 psi]	FD - 5

Fan Drive HICs	Model No.	Description	Flow	Pressure	Page
	RFDE-120-000	Fan Drive HIC with Reversing Control	Up to 120 l/min [31.7 US gal/min] See performance chart	210 bar [3000 psi]	FD - 7

Fan Drive HICs	Model No.	Description	Flow	Pressure	Page
	RFDE-40-PRV	Fan Drive HIC with Proportional and Reversing Control	10 - 40 l/min [2.6 - 10.5 US gal/min]	210 bar [3000 psi]	FD - 9
	RFDE-80-PRV		20 - 80 l/min [5.3 - 21.1 US gal/min]	210 bar [3000 psi]	FD - 9

Fan Drive HICs	Model No.	Description	Flow	Pressure	Page
	RFDE-120-PRV	Fan Drive HIC with Proportional and Reversing Control	Up to 120 l/min [31.7 US gal/min] See performance chart	210 bar [3000 psi]	FD - 11



Fan Drive HIC Technical Information

Application notes

OVERVIEW

Off-highway mobile machinery OEMs and distributors can choose from six pre-engineered Hydraulic Integrated Circuits (HICs) designed to provide speed control and reversing for hydraulic modulating fan drive motors in open circuit hydraulic fan drive systems. The program includes:

- 40, 80, and 120 LPM Frame Sizes
- Variable piston pump or fixed pump circuits
- Over-Pressure Protection / Anti-Cavitation is standard
- Viton O-rings are standard

40 & 80 LPM	120 LPM
RFDE-40-000 & RFDE-80-000	RFD-120-000

Variable pump fan drive circuits:

- Provide reversing control and over-pressure protection/anti-cavitation

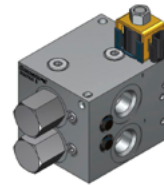

Fixed pump fan drive circuits:

- Provide modulating and reversing control with over-pressure protection/anti-cavitation

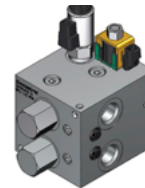

RFDE-40-PRV & RFDE-80-PRV	RFD-120-PRV
---------------------------	-------------

Functions

- Proportional relief valve:
 - Regulates fan speed by controlling pressure drop across fan motor
 - Normally closed to ensure full fan speed in the absence of electrical signal
 - PLUS+1[®] compliant
- Piloted directional control valve:
 - Reverses flow to the fan motor to reverse fan direction
 - Open transition spool reduces pressure spikes during reversals
 - Sized to minimize parasitic losses due to pressure drop
- Dual shock valve with anti-cavitation checks:
 - Trims the maximum motor torque by absorbing pressure spikes (shock effects) at the work ports
 - Anti-cavitation feature allows additional flow to the motor through the tank port when motor overruns the pump
 - PVLP shock valves (from PVG) allow for a compact design
- Custom designs available upon request



Circuits - Variable Pump or Fixed Pump

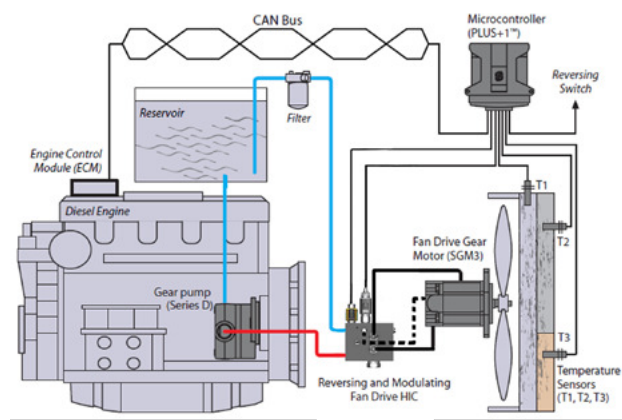
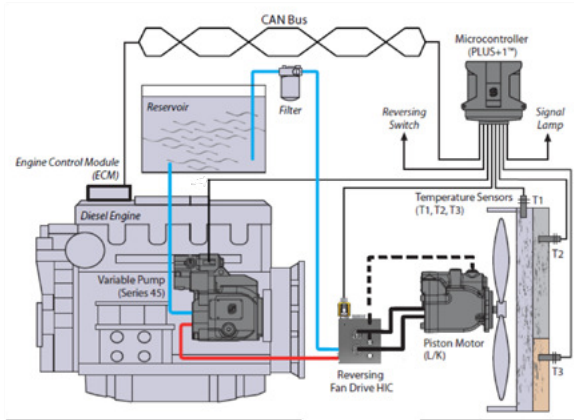

RFDE-40-000, RFDE-80-000 & RFD-120-000

- Variable Pump fan drive circuits
- HIC provides reversing control and over-pressure protection/anti-cavitation
- Variable pump provides modulation (speed control)

RFDE-40-PRV, RFDE-80-PRV & RFD-120-PRV

- Fixed Pump fan drive circuits
- HIC provides modulating and reversing control with over-pressure protection/anti-cavitation

Features

- Proportional Fan Speed Control:
 - Electronically match fan speed with cooling demand
 - Conserve engine power and fuel for the majority of operating conditions - as compared to non-proportional systems
- Increased design flexibility:
 - The compact HIC can be placed in the most suitable location on the machine
 - Minimize fan system pressure losses when choosing the optimal fan drive HIC size for the application
 - Internal and external reversing pilot options available (40 LPM & 80 LPM)
 - Drain port included on all models for motor case drain
 - Robust IP69K Deutsch coil standard for all three sizes
- Increased productivity:
 - Fan is reversible to purge (de-clog) coolers and radiators
 - Prevents overheating with purged cooler
 - More power available for useful work when radiator is not clogged



Features (continued)

- Automatic cleaning sequence programmed using PLUS+1™:
 - Manual or automatic activation
 - Reference Danfoss Power Solutions ‘Fan Drive Application Block’ information
- Custom designs available upon request

Service screen below illustrates an example reversing fan drive software setup

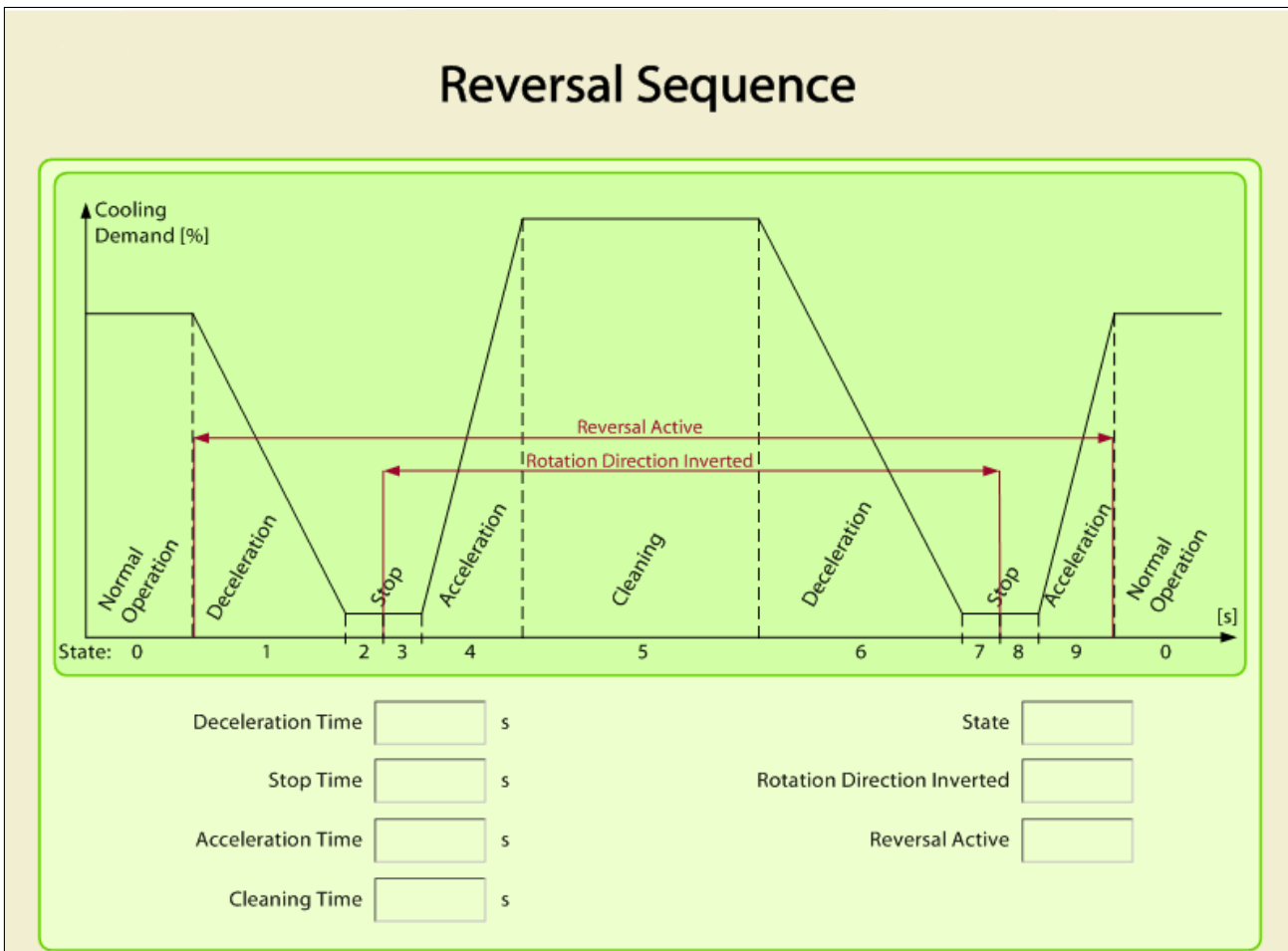



Fan Drive HIC Technical Information

Reversing Control

RFDE-40-000 & RFDE-80-000

OPERATION

This HIC reverses flow to the fan motor to reverse fan direction. It includes a DV15-P5-FD open transition spool valve to reduce pressure spikes during reversals. Internal and external piloting options are available. The HIC trims the maximum motor torque by absorbing pressure spikes at the work ports. An anti-cavitation feature allows additional flow to the motor when the motor over-runs the pump.

APPLICATIONS

This HIC can be used for fan reversal in circuits using a variable pump. Use this HIC for mobile equipment such as wheel loaders for purging (de-clogging) coolers and radiators to prevent overheating and increase cooling system efficiency. A drain port is included for motor case drain.



SPECIFICATIONS

Rated pressure	210 bar [3045 psi]
Flow range - RFDE-40-000	10 - 40 l/min [2.6 - 10.5 US gal/min]
Flow range - RFDE-80-000	20 - 80 l/min [5.3 - 21.1 US gal/min]
Weight	3.8 kg [8.37 lb]
Valves	DV15-P5-24-FD, SVP08-NC, PVLP
Minimum shift pressure	2 bar [29 psi]
Robust Coil (Standard)	R13 16 Watt (IP69K)
Diode (Optional)	Bi-directional

PERFORMANCE CURVE

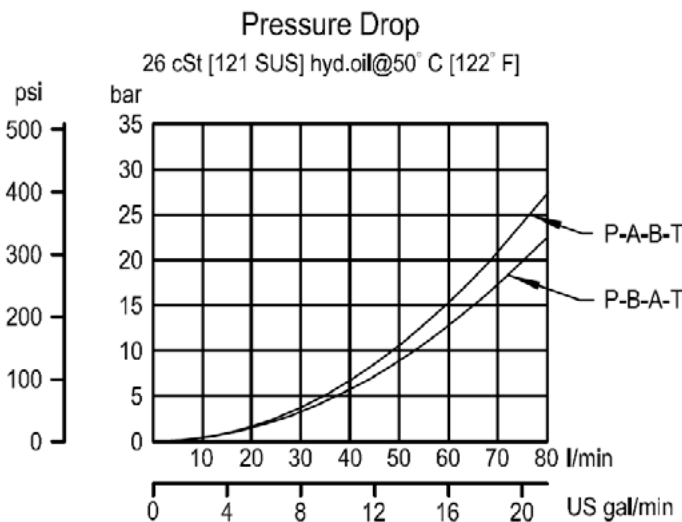

SCHEMATICS

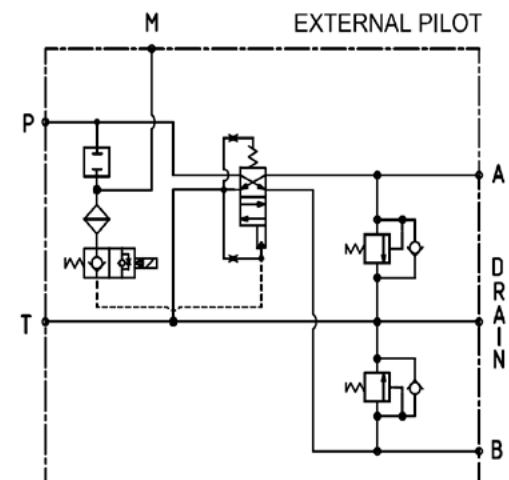
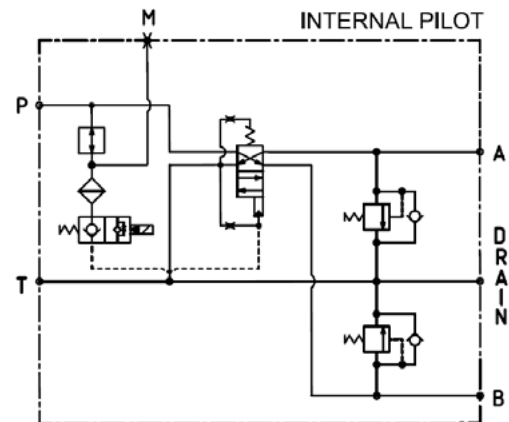



Fan Drive HIC Technical Information

Reversing Control

RFDE-40-000 & RFDE-80-000

DIMENSION DRAWING

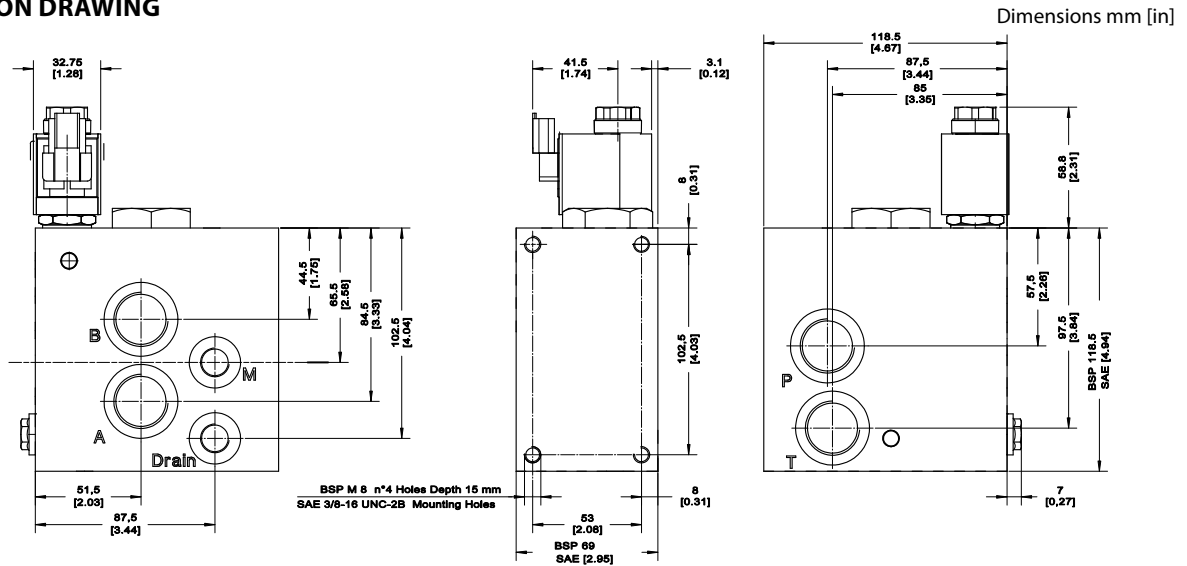

EXAMPLE CIRCUITS

Internal Pilot (00)

External Pilot (E)

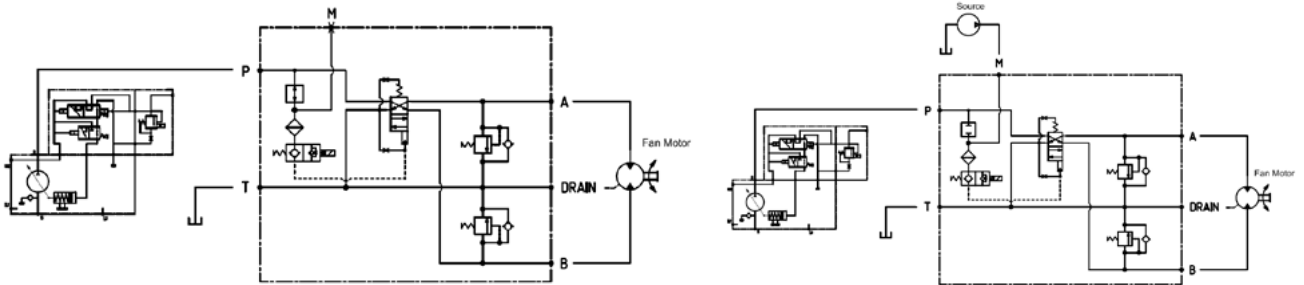

ORDERING INFORMATION

RFDE - 80 - 000 - R12D - DE - NP - 250 - E - 12S

Reversing Fan Drive,
Extended Program

Flow Capacity
40: 40 LPM [10.5 GPM]
80: 80 LPM [21.7 GPM]

000:
No Proportional Relief Valve;
Variable Pump Circuit

Coil Voltage & Termination

Voltage Description	Termination Description (Solenoid Valve)	Solenoid Valve: Robust Coil (R13) Code	IP Rating
12 VDC	Deutsch	R12D - DE	IP69K
	Deutsch with Diode	R12D-DEDB	IP69K
24 VDC	Deutsch	R24D - DE	IP69K
	Deutsch with Diode	R24D - DEDB	IP69K

Pilot to Shift:
00: Internal Pilot
E: External Pilot

Order Code	Ports
6B	3/4 BSP, AL
12S	#12 SAE, AL

Shock valve setting (Keep at least 25 bar higher than maximum control pressure)

80 bar [1160 psi]	180 bar [2755]
100 bar [1450 psi]	210 bar [3045 psi]
125 bar [1813 psi]	230 bar [3335 psi]
150 bar [2175 psi]	240 bar [3480 psi]
175 bar [2538 psi]	250 bar [3335 psi]

NP:
No PRV Valve



Fan Drive HIC Technical Information

Reversing Control

RFD-120-000

OPERATION

The RFD-120-000 reverses flow to the fan motor to reverse fan direction. It includes open transition spools in the directional valves to reduce pressure spikes during reversals. This HIC trims the maximum motor torque by absorbing pressure spikes at the work ports. An anti-cavitation feature allows additional flow to the motor when the motor over-runs the pump.

APPLICATIONS

The RFD-120-000 can be used for fan reversal in circuits using a variable pump. Use this HIC for applications requiring up to 120 LPM (31.6 GPM) including mobile equipment such as wheel loaders for purging (de-clogging) coolers and radiators to prevent overheating and increase cooling system efficiency.

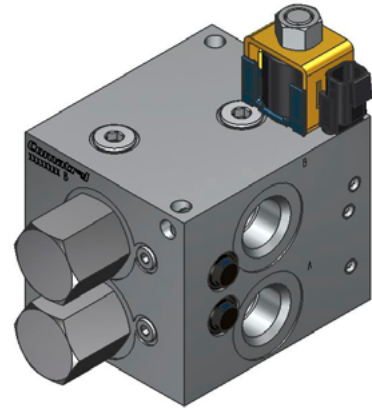

SPECIFICATIONS

Rated pressure	210 bar [3045 psi]
Flow	Up to 120 l/min [31.7 US gal/min] See performance chart
Weight	4.26 kg [9.40 lb]
Valves	CP722-5, SV08-24-01, PVLP
Robust Coil	R13 16 Watt (IP69K)
Diode (Optional)	Bi-directional

SCHEMATIC

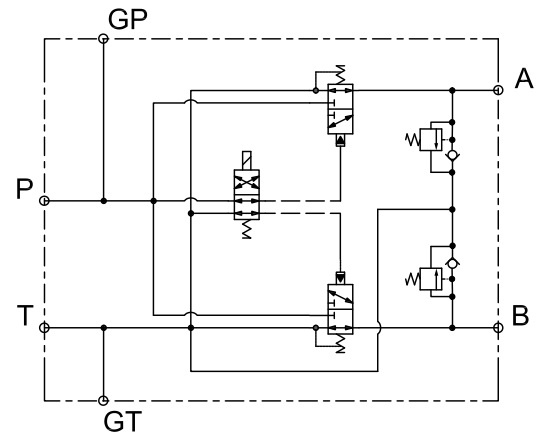

PERFORMANCE CURVE

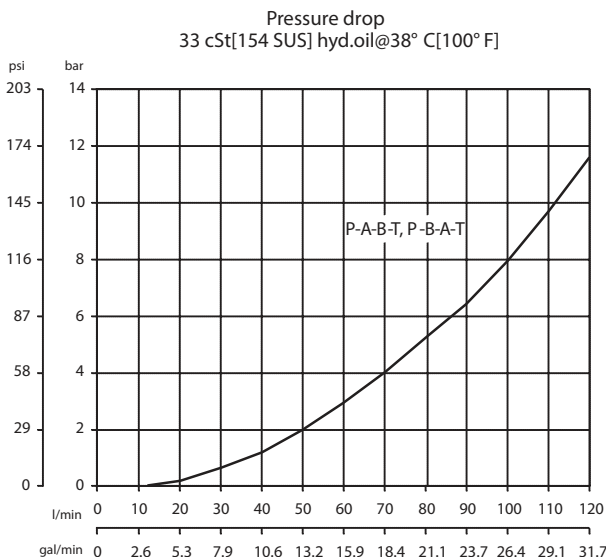



Fan Drive HIC Technical Information

Reversing Control

RFD-120-000

DIMENSION DRAWING

Dimensions mm [in]

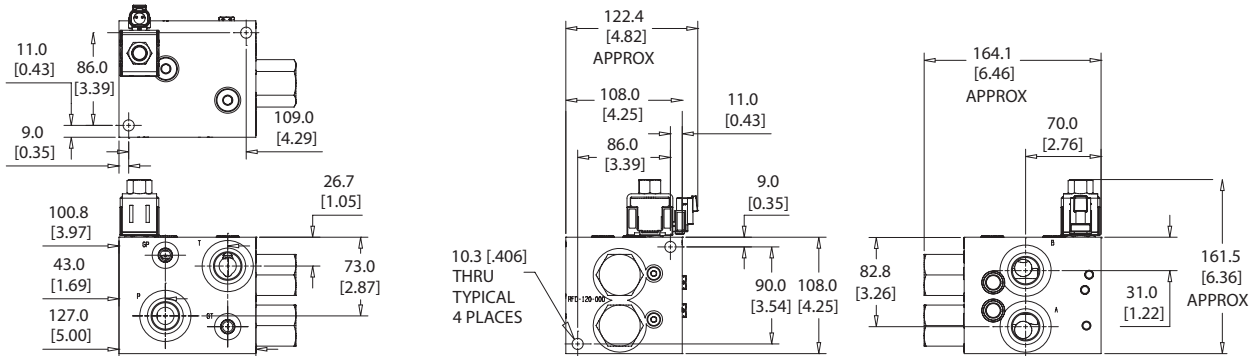

EXAMPLE CIRCUITS

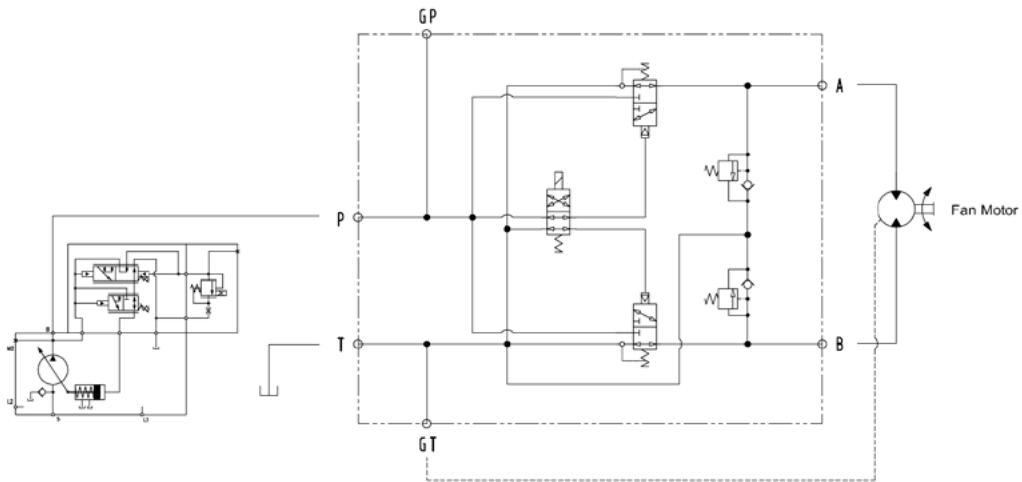

ORDERING INFORMATION

RFD - 120 - 000 - 12L - DE - NP - 250 - 12S

Reversing Fan Drive

Flow Capacity
120: 120 LPM [31.6 GPM]

000:
No Proportional Relief Valve;
Variable Pump Circuit

NP:
No PRV Valve

Order Code	Ports
6B	3/4 BSP, AL
12S	#12 SAE, AL

Shock valve setting (Keep at least 25 bar higher than maximum control pressure)

80 bar [1160 psi]	180 bar [2755]
100 bar [1450 psi]	210 bar [3045 psi]
125 bar [1813 psi]	230 bar [3335 psi]
150 bar [2175 psi]	240 bar [3480 psi]
175 bar [2538 psi]	250 bar [3625 psi]

Coil Voltage & Termination

Voltage Description	Termination Description (Solenoid Valve)	Solenoid Valve: Robust Coil (R13) Code	IP Rating
12 VDC	Deutsch	12L - DE	IP69K
	Deutsch with Diode	12L - DEDB	IP69K
24 VDC	Deutsch	24L - DE	IP69K
	Deutsch with Diode	24L - DEDB	IP69K



Fan Drive HIC Technical Information

Proportional and Reversing Control

RFDE-40-PRV & RFDE-80-PRV

OPERATION

This HIC regulates fan speed by controlling pressure drop across the fan motor. It operates in a normally closed configuration in the absence of an electrical signal. The HIC reverses flow to the fan motor to reverse fan direction. It includes a DV15-P5-FD open transition spool valve to reduce pressure spikes during reversals. Internal and external piloting options are available. This HICs trims the maximum motor torque by absorbing pressure spikes at the work ports. An anti-cavitation feature allows additional flow to the motor when the motor over-runs the pump.



APPLICATIONS

This HIC includes an integrated proportional relief valve to modulate fan speed in circuits using a fixed pump. It can also be used for fan reversal. Use this HIC for mobile equipment such as wheel loaders for purging (de-clogging) coolers and radiators to prevent overheating and increase cooling system efficiency. A drain port is included for motor case drain.

SCHEMATICS

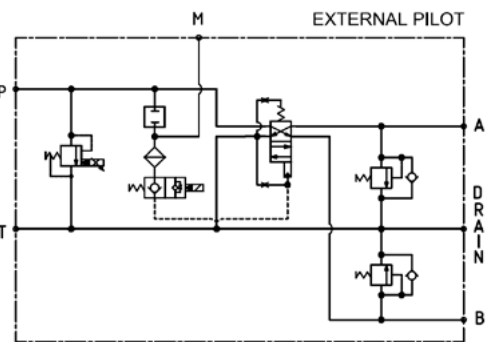
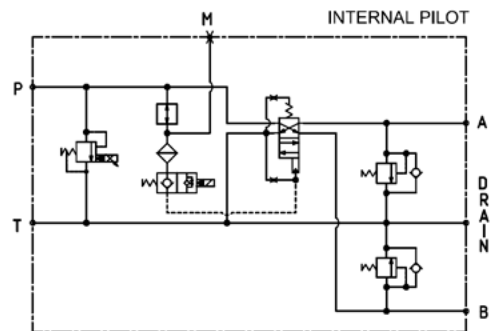

SPECIFICATIONS

Rated pressure	210 bar [3045 psi]
Flow range - RFDE-40-PRV	10 - 40 l/min [2.6 - 10.5 US gal/min]
Flow range - RFDE-80-PRV	20 - 80 l/min [5.3 - 21.1 US gal/min]
Weight	4.0 kg [9.0 lb]
Valves	DV15-P5-24-FD, SVP08-NC, PRV10-IS2, PVLP
Minimum pilot pressure	2 bar [29 psi]
Robust Coil (Standard)	R13 16 Watt (IP69K)
Diode (Optional)	Bi-directional (Not available with PRV10-IS2) M19P 22 Watt [IS2] (IP69K)

PERFORMANCE CURVES

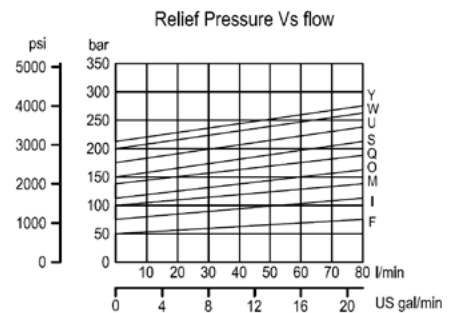
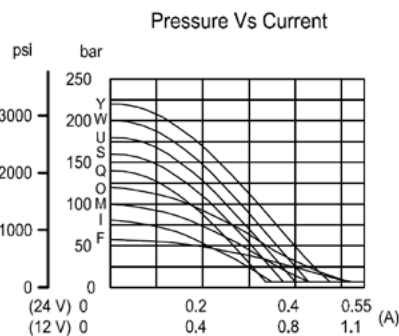
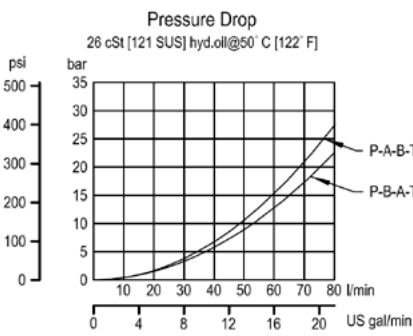



Fan Drive HIC Technical Information

Proportional and Reversing Control

RFDE-40-PRV & RFDE-80-PRV

DIMENSION DRAWING

Dimensions mm [in]

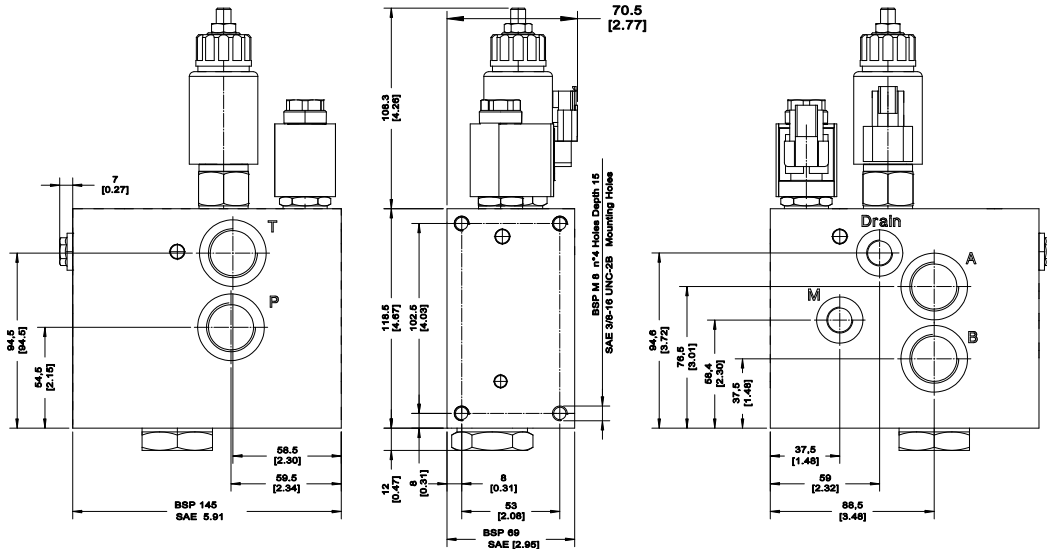

EXAMPLE CIRCUITS

Internal Pilot (00)

External Pilot (E)

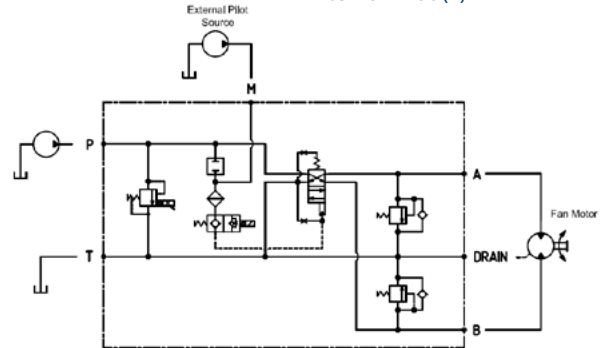
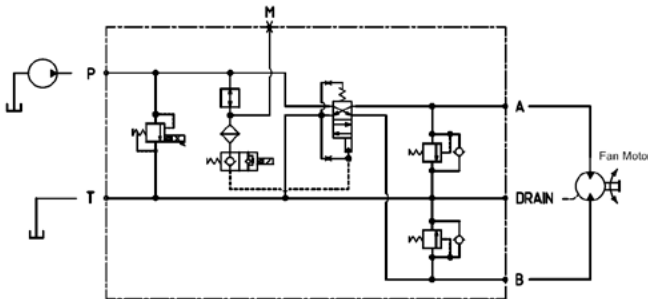

ORDERING INFORMATION

RFDE - 80 - PRV - R12D - DE - W - 250 - E - 12S

Reversing Fan Drive, Extended Program

Flow Capacity
40: 40 LPM [10.5 GPM]
80: 80 LPM [21.1 GPM]

PRV: Proportional Relief Valve, Fixed Pump Circuit

CAV: PRV replaced by cavity plug.

Coil Voltage & Termination

Voltage Description	Termination Description (Solenoid Valve / Proportional Valve)	Solenoid Valve: Robust Coil (R13) Code	IP Rating
12 VDC	Deutsch / Deutsch*	R12D - DE	IP69K
	Deutsch with Diode / Deutsch*	R12D - DEDB	IP69K
24 VDC	Deutsch / Deutsch*	R24D - DE	IP69K
	Deutsch with Diode / Deutsch*	R24D - DEDB	IP69K

* Proportional Relief Valve (PRV) coil M19P only available with Deutsch termination

Pilot to Shift:
00: Internal Pilot
E: External Pilot

Order Code	Ports
6B	3/4 BSP, AL
12S	#12 SAE, AL

Shock valve setting (Keep at least 25 bar higher than maximum control pressure)

80 bar [1160 psi]	180 bar [2755]
100 bar [1450 psi]	210 bar [3045 psi]
125 bar [1813 psi]	230 bar [3335 psi]
150 bar [2175 psi]	240 bar [3480 psi]
175 bar [2538 psi]	250 bar [3635 psi]

Proportional Relief Setting

F 55 bar [709 psi]	S 155 bar [2248 psi]
I 85 bar [1233 psi]	U 185 bar [2683 psi]
M 105 bar [1523 psi]	W 205 bar [2973 psi]
O 125 bar [1813 psi]	Y 225 bar [3263 psi]
Q 135 bar [1958]	NP No Setting (CAV option only)



Fan Drive HIC Technical Information

Proportional and Reversing Control

RFD-120-PRV

OPERATION

The RFD-120-PRV regulates fan speed by controlling pressure drop across the fan motor. It operates in a normally closed configuration in the absence of an electrical signal. This HIC reverses flow to the fan motor to reverse fan direction. It includes open transition spools in the directional valves to reduce pressure spikes during reversals. The RFD-120-PRV trims the maximum motor torque by absorbing pressure spikes at the work ports. An anti-cavitation feature allows additional flow to the motor when the motor over-runs the pump.

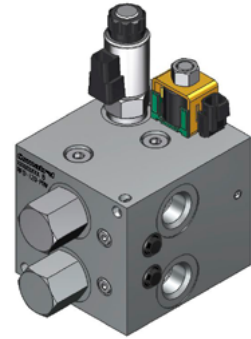

APPLICATIONS

The RFD-120-PRV includes an integrated proportional relief valve to modulate fan speed in circuits using a fixed pump. It can also be used for fan reversal. Use this HIC for mobile equipment for applications requiring up to 120 LPM (31.6 GPM) such as wheel loaders for purging (de-clogging) coolers and radiators to prevent overheating and increase cooling system efficiency.

SCHEMATIC

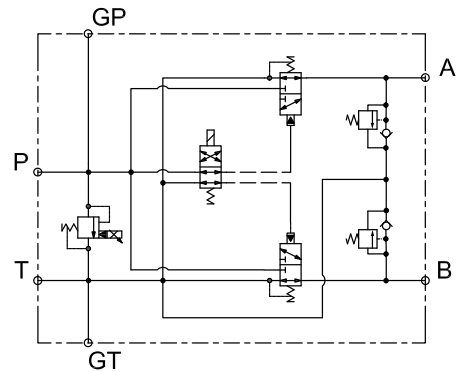

SPECIFICATIONS

Rated pressure	210 bar [3045 psi]
Flow	Up to 120 l/min [31.7 US gal/min] See performance chart
Weight	15.7 kg [6.93 lb]
Valves	CP722-5, SV08-24-01, PRV12-IS2, PVL P
Robust Coil (Standard)	R13 16 Watt (IP69K)
Diode (Optional)	Bi-directional (Not available with PRV12-IS2) M19P 22 Watt [IS2] (IP69K)

PERFORMANCE CURVES

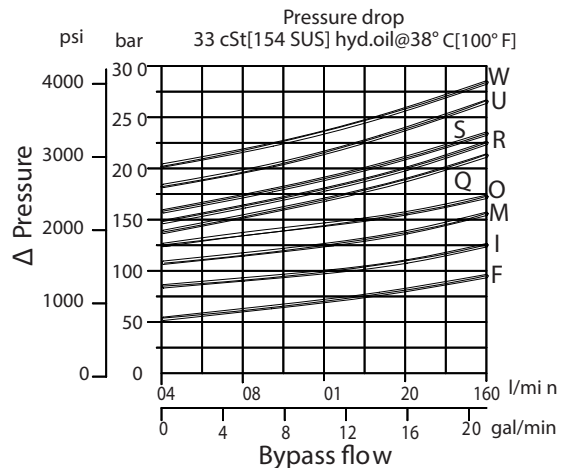
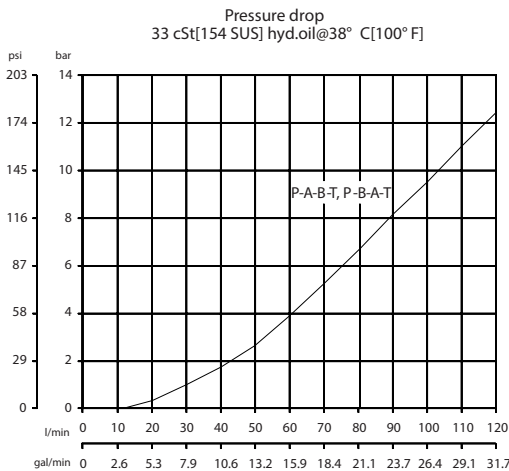



Fan Drive HIC Technical Information

Proportional and Reversing Control

RFD-120-PRV

DIMENSION DRAWING

Dimensions mm [in]

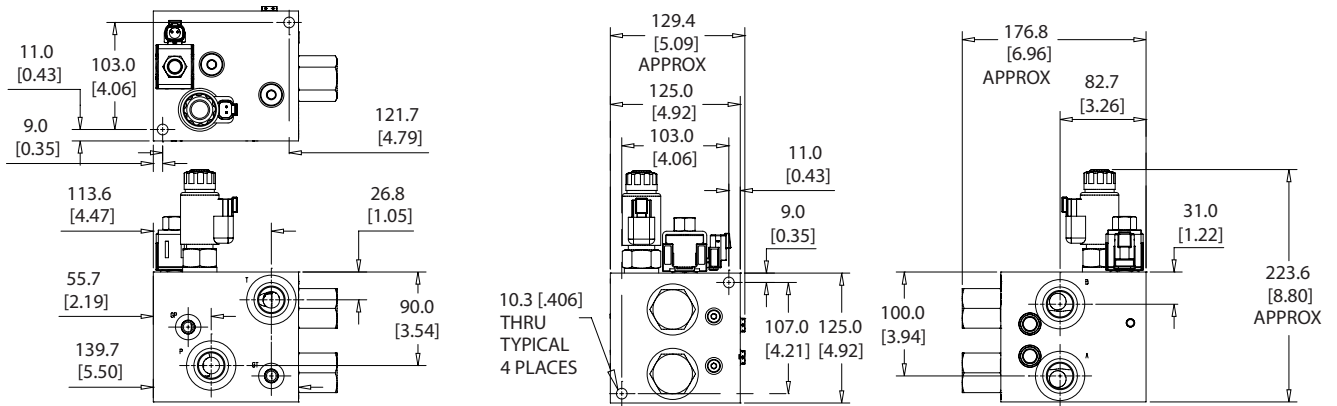

EXAMPLE CIRCUITS

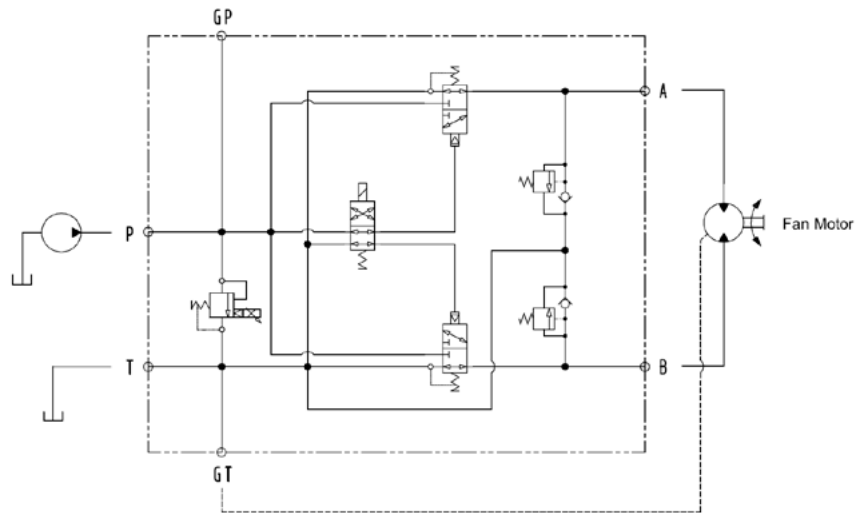

ORDERING INFORMATION

RFD - 120 - PRV - 12L - DE - W - 250 - 12S

Reversing Fan Drive

Flow Capacity
120: 120 LPM [31.6 GPM]

PRV:
Proportional Relief Valve;
Fixed Pump Circuit

Order Code	Ports
6B	3/4 BSP, AL
12S	#12 SAE, AL

Shock valve setting (Keep at least 25 bar higher than maximum control pressure)

80 bar [1160 psi]	180 bar [2755]
100 bar [1450 psi]	210 bar [3045 psi]
125 bar [1813 psi]	230 bar [3335 psi]
150 bar [2175 psi]	240 bar [3480 psi]
175 bar [2538 psi]	250 bar [3625 psi]

Coil Voltage & Termination			
Voltage Description	Termination Description (Solenoid Valve/Proportional Valve)	Solenoid Valve: Robust Coil (R13) Code	IP Rating
12 VDC	Deutsch / Deutsch*	12L - DE	IP69K
	Deutsch with Diode / Deutsch*	12L - DEDB	IP69K
24 VDC	Deutsch / Deutsch*	24L - DE	IP69K
	Deutsch with Diode / Deutsch*	24L - DEDB	IP69K

* Proportional Relief Valve (PRV) coil M19P only available with Deutsch termination

Proportional Relief Setting

F 50 bar [725 psi]	Q 145 bar [2103]
I 80 bar [1160 psi]	S 165 bar [2393 psi]
M 105 bar [1523 psi]	U 190 bar [2756 psi]
O 125 bar [1813 psi]	W 210 bar [2973 psi]