

ENGINEERING
TOMORROW



Technical Information

Electrohydraulic Actuators

PVED-CX4 Series 7



Revision history

Table of revisions

Date	Changed	Rev
April 2023	Updated tables and graphs	0301
January 2023	Added Service chapter and updated standards	0201
February 2022	First edition	0101

Contents

Reference

Acronyms used for PVG and PVE..... 7
 Literature reference for PVG/PVE products.....8
 Standards used for PVED-CX4.....8

General information

PVED-CX4 introduction..... 9
 PVED-CX4 Overview..... 10

PVG functionality

PVG functionality..... 12

PVED-CX4 functionality

PVED-CX4 functionality..... 13
 Mechanical subsystem..... 13
 Housing..... 13
 PVED-CX4 Cable kit..... 13
 Mounting..... 14
 Linear Variable Differential Transducer (LVDT)..... 14
 Spool neutral spring..... 15
 Hydraulic subsystem..... 15
 Electrical and electronic subsystem..... 15
 PVED-CX4 Communication..... 16
 Computerized subsystem..... 17
 Operational modes..... 18
 Full operational..... 18
 Hand operational..... 18
 Automatic system safety integrity self test – ASSIST 18
 PVED-CX4 settings..... 19
 PVED-CX4 Logging..... 19

Normal operation – self and neighbor supervision concept

Set point command..... 20
 Spool supervision..... 21
 Solenoid control..... 21
 Position reporting..... 21
 Neighbor supervision..... 21
 Microcontroller supervision..... 21
 Temperature supervision..... 21
 Power save for PVED-CX4..... 21

PVED-CX4 Safety description

POST – Power On Self Test..... 22
 ASSIST – Automatic System Safety Integrity Test..... 22
 PVED-CX4 runtime fault monitoring..... 22
 Communication fault..... 22
 Spool position fault..... 22
 System data fault..... 23
 Electrical fault..... 23
 Temperature fault and correction..... 23
 Test fault..... 23
 Fault level..... 23
 PVED-CX4 fault reaction..... 24
 Fault reporting..... 24
 PVED-CX4 Fault Tolerance Timing Intervals (FTTI) for Spool monitoring..... 25
 PVED-CX4 Fault Detection Time for CAN-Bus..... 25
 PVED-CX4 fault recovery..... 25

Service

PVED-CX4 maintenance..... 26
 Decommissioning PVED-CX4..... 26

Contents

Technical data

PVED-CX4 operational conditions.....	27
Performance.....	27
PVED-CX4 Dimensions and layout.....	28
PVED-CX4 hydraulic data.....	31
PVED-CX4 electrical data.....	32
Communication.....	33
PVED-CX4 LED	33
CAN.....	33
Spool control.....	34
PVED-CX4 spool positioning.....	34
Closed loop.....	34
Spool monitoring, control and fault reaction.....	34
Parameter settings.....	35
Node Id.....	35
EDS parameters – constants read only.....	36
EDS parameters – variables read write.....	36
Error register. Variable read only.....	37
Conversion of identity parameters to comparable values.....	37
Reading guide for product code and serial number.....	37
Byte reading guide.....	38
Reading guide for numbers	38
Error log. Variables, read only, volatile.....	38
Error list. Variable read only.....	38
Instantaneous temperature. Variable read only.....	39
Temperature log.....	39
Safety Switch status.....	39
Safety relevant features.....	40
Emergency msg. (EMCY).....	40
EMCY publishing order on CAN bus.....	40
Reset Emergency Message.....	40
EMCY consumer behavior.....	41
NMT reset application.....	41
NMT reset communication.....	41
Reload Command.....	42
Important Points for PVED-CX4 Valve Configuration.....	42
Changing Node ID using Layer Setting Service.....	43
Step 1: Switch to configuration mode.....	43
Switch To Configuration Mode Global Way.....	43
Switch to Configuration Mode Selective Way.....	43
Step-2: Configure Node ID.....	44
Step-3: Store New Assigned Node-ID.....	44
Step-4: Switch to Normal Mode.....	45
LSS Enquiry Services.....	45
Enquire Vendor-ID Command.....	45
Enquire Product Code Command.....	45
Enquire Revision Number Command.....	46
Enquire Serial Number Command.....	46
Enquire Device Node-ID Command.....	47
EDS access by SDO.....	47
Set EDS parameter.....	47
Set NNI example.....	47
Enquire EDS parameter.....	48
Enquire NNI example.....	48
Enquire error log example.....	48
Valve operation.....	49
Normal Operation.....	49
NMT boot up object.....	49
Heartbeat Message.....	49

Contents

Getting to Device Mode Active.....	50
PVED-CX4 node 0x21.....	50
PVED-CX4 node NID.....	51
Set point.....	52
The Sync message:.....	52
Transmission of PVED-CX4 Spool Pos. Messages on Sync Msg.....	53
Hand Operational Mode and Full Operational Mode configuration	53
ASSIST.....	54
ASSIST Pre-Trigger Command.....	54
ASSIST Run Command.....	55
LED by ASSIST	56
CANCEL ASSIST Command.....	57
ASSIST Abort Message.....	58

State machine

Important points about PVED-CX4 DSM Implementation.....	59
INIT state:.....	59
DISABLED state:.....	59
HOLD state:.....	59
DEVICE_MODE_ACTIVE state:.....	60
PVED-CX4 hand operational mode.....	61
PVED-CX4 full operational mode	61
ASSIST Mode	61
FAULT_REACTION state:.....	61
FAULT_HOLD state:.....	62
FAULT state:.....	62
State Transition.....	62

Limitations and Known Software Issues

Warnings

PVED-CX4 warnings.....	65
------------------------	----

Error codes

Index 1 • Common Name: Reserved.....	66
Index 2 • Common Name: Supply voltage too high.....	66
Index 3 • Supply voltage too low.....	66
Index 4 • Illegal state command.....	67
Index 5 • Division by zero, illegal SW operation.....	67
Index 6 • Internal table value corrupted, illegal SW operation.....	68
Index 7 • Wrong data interpretation, truncation of values.....	68
Index 8 • Interpolation fault, illegal SW operation.....	69
Index 9 • No handshake to μ C.....	69
Index 10 • Watchdog not starting.....	69
Index 11 • RTOS error.....	70
Index 12 • LVDT verification fault.....	70
Index 13 • Neighbor LVDT fault.....	71
Index 14 • Temperature sensor fault.....	71
Index 15 • Fault In RAM.....	71
Index 16 • Temperature average to high.....	72
Index 17 • Code memory check fault.....	72
Index 18 • Reserved.....	73
Index 19 • EEPROM write fault.....	73
Index 20 • EEPROM content fault.....	73
Index 21 • EEPROM mirror fault.....	74
Index 22 • Dead band parameter out of range.....	74
Index 23 • Reserved.....	74
Index 24 • CAN error frame warning.....	75
Index 25 • Signal from master missing.....	75
Index 26 • Recovered from Bus off.....	76
Index 27 • Command signal error.....	76

Contents

Index 28 • Reserved.....	76
Index 29 • Reserved.....	77
Index 30 • Spool not at set point.....	77
Index 31 • Spool out of neutral.....	78
Index 32 • Spool out of neutral at boot up.....	78
Index 33 • Electronics to warm.....	78
Index 34 • CAN spool position from neighbor missing.....	79
Index 35 • Neighbor CAN spool position fault.....	79
Index 36 • No set point.....	80
Index 37 • CAN stack error.....	80
Index 38 • DSM initialization failed.....	81
Index 39 • A/D converting fault.....	81
Index 40 • ASSIST. State fault.....	81
Index 41 • ASSIST. Timing fault.....	82
Index 42 • Neighbor. Spool out of neutral at boot up.....	82
Index 43 • ASSIST. Neighbor reporting fault.....	82
Index 44 • ASSIST. Spool not returned to neutral.....	83
Index 45 • ASSIST. Step fault.....	83
Index 46 • ASSIST. Neighbor spool does not steer out.....	84
Index 47 • ASSIST. Neighbor spool not returned to neutral.....	84
Index 48 • ASSIST: A port gives to high flow.....	85
Index 49 • ASSIST: B port gives to high flow.....	85
Index 50 • ASSIST: A port gives to low flow.....	85
Index 51 • ASSIST: B port gives to less flow.....	86
Index 52 • Neighbor. Spool out of neutral.....	86
Index 53 • Neighbor. Spool not at set point.....	87
Index 54 • Neighbor. Spool position reporting fault.....	87
Index 55 • Reference voltage fault.....	88
Index 56 • Node ID fault.....	88
Index 57 • EEPROM address fault.....	88
Index 58 • Error code buffer.....	89

Ordering information

Settings Agreement.....	90
Parameter Agreement Template.....	90
Factory settings for spare part PVED-CX4.....	90
PVED-CX4 setting agreement for PVG.....	91
PVED-CX4 code numbers.....	92
PVED-CX4 spare part code numbers.....	93

Reference

Acronyms used for PVG and PVE

Acronyms	Description
ATEX	Certificated for use in explosive environment
AVC	Auxiliary Valve Command - ISOBUS/J1939 standard signal for valve control
AVCTO	Auxiliary Valve Command Time Out - Fault monitoring setting
AVEF	Auxiliary Valve Estimated Flow - ISOBUS/J1939 standard signal for valve feedback
CAN	Controller Area Network - Communication method used by PVED
CLC	Closed Loop Circuit
CRC	Cyclic Redundancy Check - Method for ensuring validity of data.
-DI	PVE with Direction Indication
DM1	Diagnostic Message 1 - J1939 message informing about present fault
DM2	Diagnostic Message 2 - J1939 message informing about fault history
DM3	Diagnostic Message 3 - J1939 message clearing fault history
DSM	Device State Machine. Deterministic description of system process
ECU	Electronic Control Unit
EH	Electro Hydraulic
-F	PVE for Float spool. Two variants: 4 pin with float at 75%. 6 pin with separate float.
FMEA	Failure Mode Effect Analysis
ISOBUS	Communication standard for CAN
J1939	Communication standard for CAN
LED	Light Emitting Diode
LS	Load Sensing
LVDT	Linear Variable Differential Transducer - Position sensor
NC	Normally Closed solenoid valve in PVE
NC-H	Normally Closed standard solenoid valve in PVEH
NC-S	Normally Closed solenoid valve Super in PVES
NO	Normally Open solenoid valve in PVE
PLC	Programmable Logical Circuit
PLUS+1®	Trademark for Danfoss controllers and programming tool
POST	Power On Self Test. Boot up evaluation for PVED
Pp	Pilot Pressure. The oil gallery for PVE actuation
PVB	Proportional Valve Basic module - valve slice
PVBS	Proportional Valve Basic module Spool
PVBZ	Proportional Valve Basic module Zero leakage
PVE	Proportional Valve Electric actuator
PVEA	PVE variant with 2-6 % hysteresis
PVED	PVE variant Digital controlled via CAN communication
PVEH	PVE variant with 4-9% Hysteresis
PVEM	PVE variant with 25-35% hysteresis
PVEO	PVE variant with ON/OFF actuation
PVEP	PVE variant PWM controled
PVES	PVE variant with 0-2% hysteresis
PVEU	PVE variant with US 0-10V
PVG	Proportional multi-section Valve Group
PVHC	PV variant with High Current controlled valve actuator
PVM	Proportional Valve Manual control with handle
PVP	Proportional Valve Pump side module.Inlet

Reference

Acronyms	Description
PVS	Proportional Valve end plate
PVSK	Proportional Valve end plate crane. Inlet module with Spool Control
PWM	Pulse Width Modulation
S4 DJ	Series 4 Digital J1939 service tool software for PVED-CC
SAE	Society Automotive Engineering
-R	PVE with Ramp function
-NP	PVE with solenoid disable in Neutral Position
-SP	PVE with Spool Position feedback
μC	Microcontroller
μCSM	Microcontroller State Machine
U _{DC}	Power supply Direct Current; also called V _{bat} for battery voltage
U _s	Steering voltage for the PVE control; also called V _s

Literature reference for PVG/PVE products

Literature reference

Literature title	Type	Order number
PVG 32 Proportional valve group	Technical Information	BC152886483 664
PVG 100 Proportional valve group	Technical Information	BC152886483 475
PVG 120 Proportional valve group	Technical Information	BC152886483 344
PVG 32 Metric ports	Technical Information	BC152886484 163
PVED-CC Electro-hydraulic actuator	Technical Information	520L0665
PVED-CX Electro-hydraulic actuator	Technical Information	BC152886483 682
Basic module for PVBZ	Technical Information	BC152886484 167
PVSK module with integrated diverter valve and P-disconnect function	Technical Information	BC152886484 133
PVPV / PVPM pump side module	Technical Information	BC152886484 316
Combination module PVGI	Technical Information	BC152886483 392
PVSP/M Priority module	Technical Information	BC152886484 066

Standards used for PVED-CX4

- International Organization for Standardization:
 - ISO 11898-2:2016 Road vehicles, CAN, Part 2, High-speed medium access unit (physical layer)
 - ISO 13766:2006(E) Earth moving machinery, Electromagnetic compatibility
 - ISO 13849-1:2015 Safety of Machinery
- CAN in Automation:
 - CiA 3.01 v4.02 CANopen protocol.
 - CiA 4.08 v1.51 Device specific protocol for proportional valves.
- IEC 61508 Ed 2.0:2010

General information

PVED-CX4 introduction

The Danfoss PVED-CX4 is a PVE-Series 7 actuator for the PVG 32.

CX is an abbreviation for CAN bus communication and eXtended safety.

The PVED-CX4 is intended for markets where a documented extended safety is needed. In particular cranes, man-lifts and telehandlers are in focus.

A PVG with PVED-CX4 is designed to meet Safety Integrity Level 2 (SIL2) and Performance Level PL d with Category 2. So when performing a Risk and Hazard Analysis, as mandated by the EU Machinery Directive 2006/42/EC, the Danfoss customer can cut down on external safety systems and easier get an IEC61508 or ISO13849 certified system.

A product specific wiring harness is part of the PVED-CX4 concept as use of the special Danfoss end plate for cranes (PVSK) is.

Certification of the PVED-CX4 system appliance to the IEC61508 is made by TÜV SÜD, Munich, Germany.

PVG with PVED-CX4



PVED-CX4, front view



PVED-CX4, back view



General information

- 3 – PVG with PVED-CX4
- 4 – Safety switch
- 5 – Emergency

- 8 – Analog neighbor information
- 9 – Neighbor surveillance can cut the oil flow
- 10 – Set points and feedback

The PVED-CX4 uses the CANopen protocol, thus following the standard protocol CiA301v402 and the device specific protocol for proportional valves CiA408v151 with a minimum set of vendor specific additions.

The physical layer for CAN communication applies to ISO 11898-2 high speed CAN.

The spool is controlled by spool position with 127 positions each direction and dead band compensation. Monitored manual operation is possible.

Electronics and spool control are independently power supplied and the redundant system monitoring can shut down the whole control section in case of failures.

The redundant monitoring continuously evaluates spool position, communication, electronics, memory, calculations and temperature.

To avoid needless power consumption the PVED-CX4 has the Power Save feature, where power consumption is reduced by almost 90% when the spool is in neutral.

PVG 32 with PVED-CX4 overview

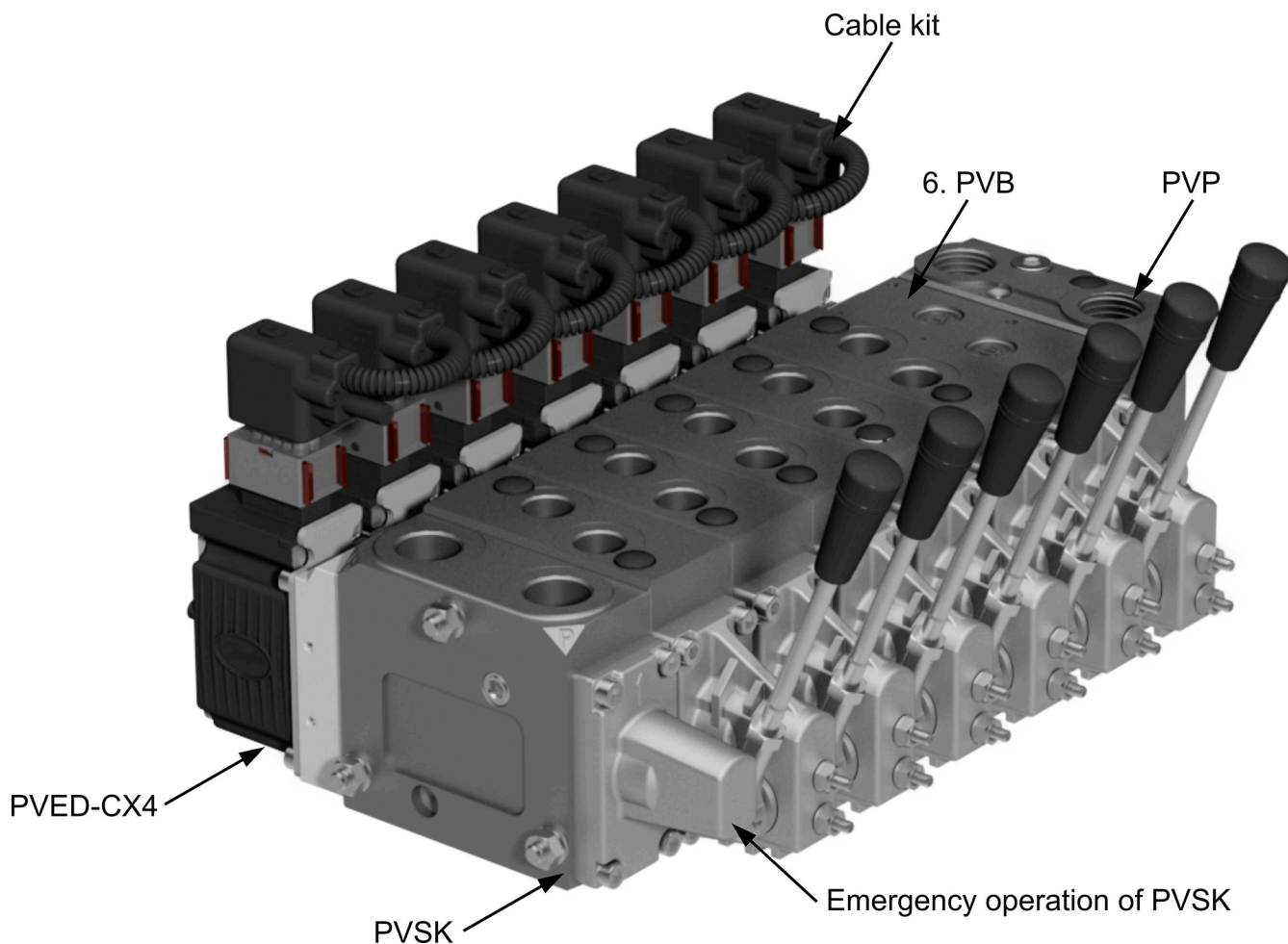

PVG functionality

PVG functionality

This chapter will give an overview of the PVG and its functionality.

Valve section with naming - standard mounted - seen from PVP

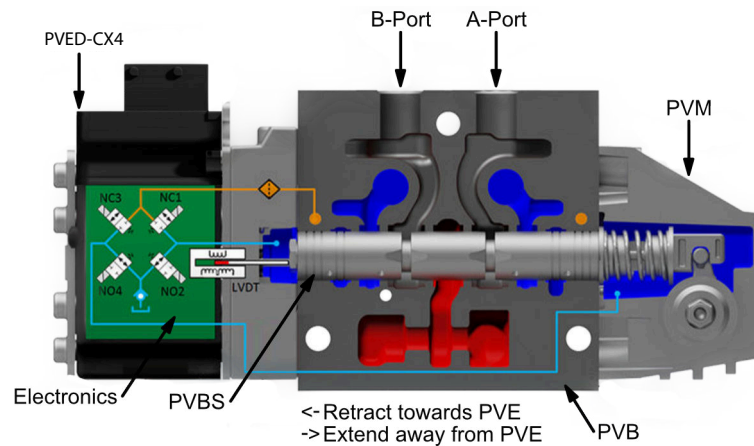

The PVG valve distributes oil from pump flow to a particular work function in the application via a specific valve section. This is done by moving the spool (PVBS).

Depending on the choice of components the oil work flow enters the PVG through the PVP (proportional valve pump side module) or the PVSK (proportional valve end plate for crane) and enters the PVB (proportional valve basic module) via the P gallery and leaves through the T gallery.

In the figure above you see a valve section seen from PVP towards PVSK with the PVM and PVE standard mounted. PVM and PVE can in general be interchanged, that is called option mounted.

With the spool in neutral, where it is kept by the neutral spring, the connection to the application via ports is blocked.

Moving the spool towards the PVE, as in figure 4, opens a connection between P and A and also between B and T. This is done by either pushing the PVM or sending a retract command to PVED. The PVED move the spool by letting Pilot Oil Pressure (Pp) push on the right end of the PVBS and releasing pressure from the left end. For details on PVG please see relevant technical information.

Any PVG with PVM can be operated by PVM alone, independent of a power supply. Any PVG with PVED-CX4 can monitor PVBS if power and communication conditions are present.

PVED-CX4 functionality

PVED-CX4 functionality

This section has focus on how the PVED-CX4 works and interacts. Understanding of this must be regarded as a pre-condition for understanding module settings and system operation.

The PVED-CX4 is a mechatronic device, meaning a mechanical, a hydraulic, an electric, an electronic and a computer system interacting with external mechanical, hydraulic, electrical, electronic and computerized systems.

PVED-CX4 mechatronical interaction

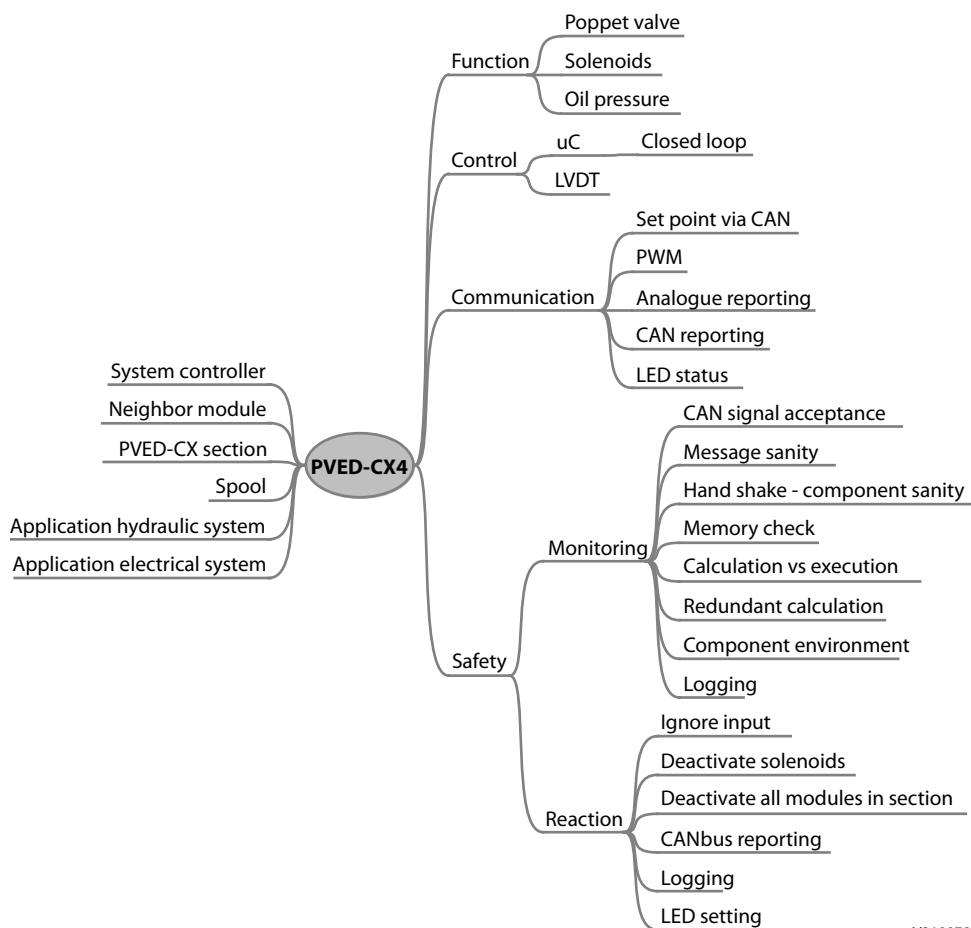

V310078.A

Mechanical subsystem

Housing

The housing of this product protects the internal parts from the environment and gives by design the optimal interface to cabling, Pilot pressure and spool.

PVED-CX4 Cable kit

A special cable kit has been designed for the PVED-CX4 making it possible to operate in control sections of two to eight modules with neighbor monitoring.

The cable has five incoming wires:

PVED-CX4 functionality

- CAN high signal wire
- CAN low signal wire
- V_{bat} for electronic power supply
- V_{bat2} for solenoid power supply
- Ground

Cable kit principle

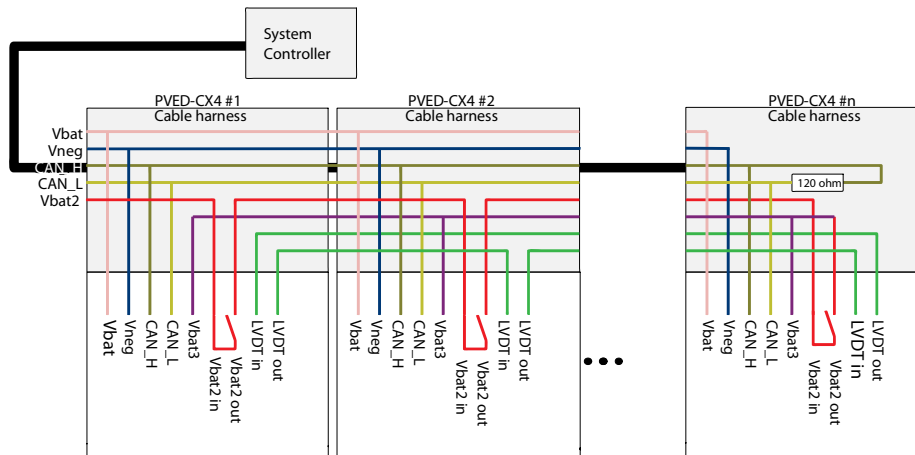

Three wires are added between the modules:

1. V_{bat2} power supply. This wire is looped as a **V_{bat2} out – V_{bat2} in** between the modules and goes through the safety switches in the modules.
2. V_{bat3} power supply is a transformation of V_{bat2} out from the last module and now used for powering the solenoid valves.
3. **LVDT out – LVDT in** signal wire. This connects the analogue spool position signal from one module to the neighbor microcontroller.

The termination in the last connector is optional.

Mounting

The Danfoss PVG concept is based on parts interchangeability. This is also valid for the PVED-CX4 and makes field retrofitting possible.

- PVED can be mounted on both ends of PVB.
- Cable kit can be mounted with first or last connector next to PVP.
- Cable kit can be delivered with and without CANbus termination.

Warning

Deviation from recommended torque can harm performance and module.

Linear Variable Differential Transducer (LVDT)

The Linear Variable Differential Transducer (LVDT) or position sensor is the interface between the mechanical system (spool) and the electronic system.

Warning

The LVDT must never be mechanically adjusted, bent, damaged or partially blocked as this will lead to incorrect information on spool position.

PVED-CX4 functionality

Spool neutral spring

The PVBS neutral spring is an important safety component as it keeps or moves the PVBS in blocked position when solenoid valves are disabled. The spring will keep the A and B port closed as long as the differential pressure is below 6 bar.

Hydraulic subsystem

The hydraulic subsystem is used for moving the spool and thereby opening the valve for work flow.

Pilot oil diagram

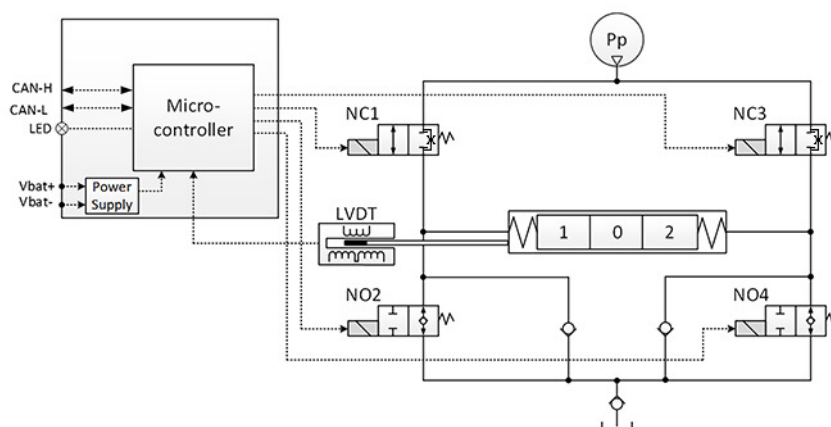

The heart of the hydraulic subsystem is the solenoid valve bridge. It consists of four poppet valves, the two upper ones are normally closed (NC-S) with a small bleed, the two lower ones are normally open (NO).

A continuous modulation of solenoid valves NC1 and NO4 together with a simultaneous energization of NO2 and de-energization of NC3 causes the main spool to move to the right direction and vice versa. When the main spool is stroked to the far right, a simultaneous energization of both NO2 and NO4 and de-energization of both NC1 and NC3 balances the main spool in its stroked position. An emergency stop activated when the spool is stroked will cause all solenoid valves to de-energize causing the main spool to move back to its neutral position by means of the main spool neutral spring and the hydraulic principle.

The Pp will work against the PVBS neutral spring when the spool is moved out of blocked (neutral) and together with the spring when going in blocked. This combined with a larger opening in the NO than in the NC-S will give a faster movement towards blocked than out of blocked.

Warning

Obstacles for the Pp can have direct influence on spool control. Reduced pilot pressure will limit spool control. Too high Pp can harm the system.

Electrical and electronic subsystem

The PVED-CX4 is based on the known closed loop (LVDT) control technology with one micro-controller core, controlling the main functionality of the solenoid valves. And a second micro-controller system as Module Safety Manager and interface between the micro-controllers and the CAN bus communication.

The micro-controllers also monitor its neighbor PVED-CX4 and has the ability to disable spool actuation for the whole control section.

PVED-CX4 functionality

Function blocks for electronics

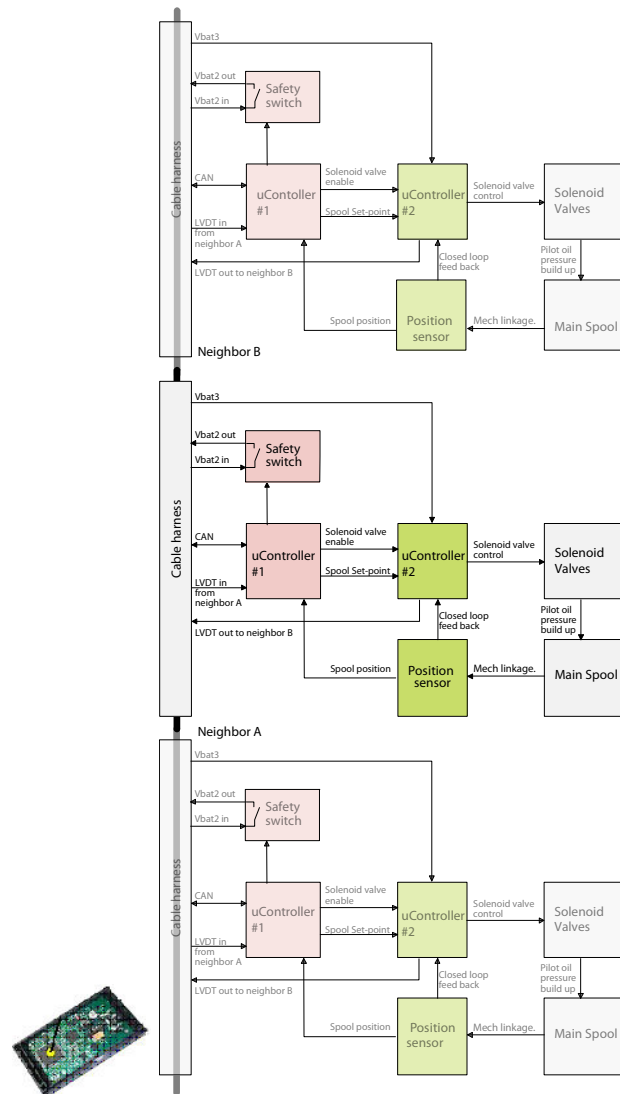

- Controller: The build in micro-controller.
- Safety switch: MOSFET for collective solenoid disabling inside the control section.
- Position sensor: Mechanical electrical interface.
- Analogue control: A closed loop control of spool position based on set point. Feedback to system is actual spool position and error state.

PVED-CX4 Communication

The PVED-CX4 has three methods of communication.

- Optical from module
- Analogue one way communication
- Digital two way communication

Optical – LED

Blinking and steady light is implemented to facilitate maintenance and application engineering.

PVED-CX4 functionality

Analogue

Analogue communication is implemented.

An analogue signal is sent from active module to monitoring module to enforce redundancy.

Module under surveillance is referred to as neighbor module in settings.

The operational mode of the module under surveillance (neighbor) decides the behavior of the monitoring module.

Digital – CANopen

The CANopen communication is the main method. It is used for:

- Control of module by master. Master defines state transition and set points.
- Reporting from module to master. Module reports spool position and safety violation
- Setting in module by master. Some parameters can be changed.
- Inquiry from master to module.

CANopen is a communication protocol defined by the society CAN in Automation (CiA). For details in the protocol we refer to CiA.

Computerized subsystem

The PVED-CX4 operates according to defined Device State Machines (DSM) giving conditions for transition between states. The Communication State Machine (CSM) is pre-condition for the DSM.

State transitions depends on internal conditions e.g. the sanity of the PVED-CX4 and can also depend on external conditions e.g. application controller commands and changes in preconditions for normal valve operation.

DSM and CSM for PVED-CX4

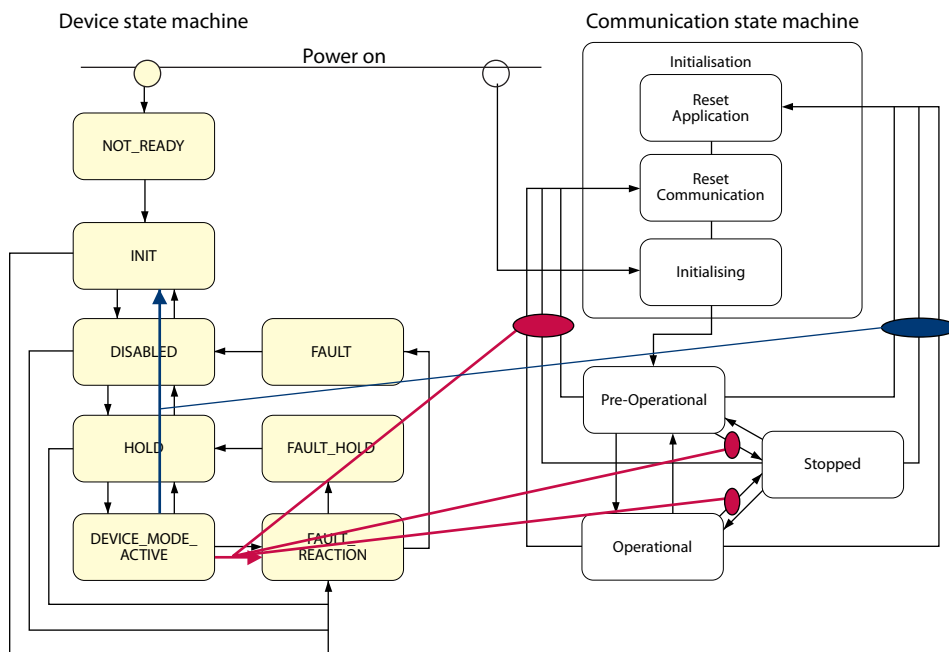

V310034.A

When power is applied to the PVED-CX4 it will initialize components and validate component states and parameter settings. This is the power on self test (POST).

If test is passed the PVED will enter Disabled State and make it self known to the controller as active. Otherwise it will enter Fault mode and if possible also generate a fault message.

PVED-CX4 functionality

When the state is Device Mode Active or Device Mode Disabled module reporting can be trusted when in fault states report validity is related to the fault type.

Operational modes

The PVED-CX4 has three accessible operational modes for normal operations.

- Full operational. Spool position is controlled and monitored. Device Mode Active.
- Hand operational. Spool position is monitored. Device Mode Disabled.
- Automatic system safety integrity self test. Device Mode Active.

It is not mandatory for all modules in the same Control Section to be in the same Operational Mode.

Fault monitoring is active independent of operational mode.

See [PVED-CX4 Safety description](#) section.

Full operational

In full operational mode the PVED-CX4 controls the spool and monitors the neighbor spool.

This mode is characterized by:

- Set point is received from Master and acted on by the module
- Solenoid valves are enabled by local switch if not in Power Save
- Neighbor monitoring of set point and spool position is active
- Spool position reporting is active
- No fault is present
- LED green

Hand operational

In hand operational mode the PVED-CX4 cannot control the spool.

This mode is characterized by:

- Spool position is defined by PVM and spool neutral spring
- Set point is not calculated. Master module does not have to send
- Solenoid valves are disabled by local switch
- Neighbor monitoring of spool reporting is active
- Spool position reporting is active
- No fault is present
- LED green.

Automatic system safety integrity self test – ASSIST

The ASSIST is as a tool for end-of-line test and maintenance test especially in connection with parts replacement and system modification.

In the ASSIST the system ability to recognize spool movement as fault and signal incongruence is tested automatically. This also includes the redundancy created by the cable harness.

The following is tested:

- Main spool kept in and brought back to neutral by spring
- The 4 magnetic solenoids
- The LVDT sensor

PVED-CX4 functionality

- The ASIC spool position reporting
- The ASIC closed loop control of the main spool position
- Node Id and neighbor node Id validity

This mode is characterized by:

- Solenoid valves are activated but not controlled by master device
- Fault monitoring and reporting has a mode specific pattern

PVED-CX4 settings

The PVED-CX4 offers a number of settings for both system information and system operation. The parameters are, as required in CANopen, organized in an Electronic Data Sheet (EDS). The available parameters are both fixed parameters and variable parameters. For details in the protocol we refer to CiA.

PVED-CX4 Logging

During operation the PVED-CX4 logs data, that can be accessed at any time.

- Error history. A runtime log, cleared by reset and power off, keeps track of error order in a FIFO buffer
- Error counts. For each error code an occurrence counter is maintained in the EEPROM
- Temperature (current)
- Temperature histogram. For every 6 minutes of run time the current temperature is logged

Normal operation – self and neighbor supervision concept

The main spool is kept in blocked/neutral position by the neutral spring. By use of the handle (PVM) or the solenoid valves and the Pp the spool can be moved to any position and so open for system pressure to the application.

Function cooperation in control section

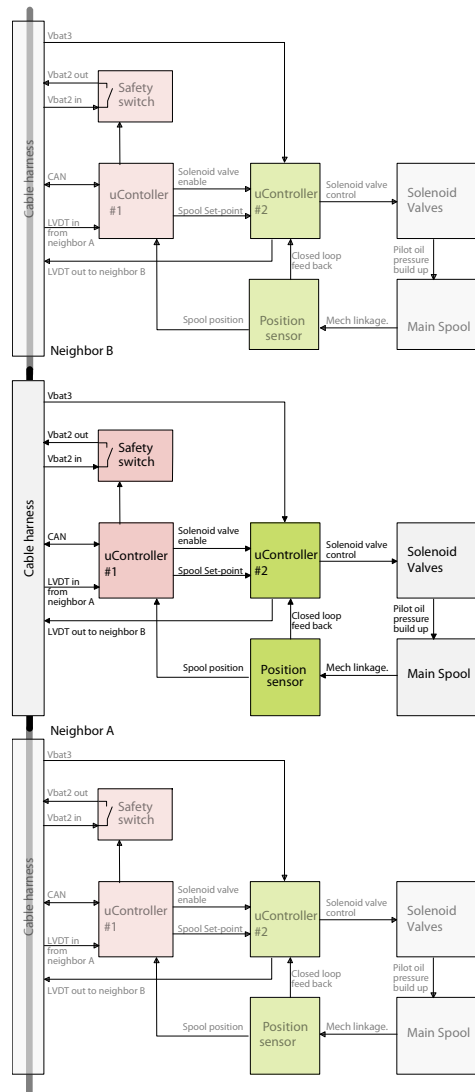

Set point command

The Set Point for the PVED is broadcasted on CAN bus by the System Main Controller/Master. During transmission the signal is evaluated for irregularity by all modules on the bus but only modules programmed for the specific signal will perform further calculations.

Upon reception the micro-controller (relevant module and neighbor) evaluates the validity of the set point.

If the set point is valid, and not blocked when power save is active, a local switch connected by the microcontroller and the solenoid valves are enabled.

The digital message is sent between the controllers evaluate if it is in the valid range.

Normal operation – self and neighbor supervision concept

Spool supervision

At any time the microcontroller monitors the spool position via the position sensor (LVDT) feedback. This determines the spool position for the closed loop control. Additionally the spool position is sent from the microcontroller to the neighbor microcontroller as an analogue signal and the LVDT feedback is also fed to the microcontroller for generation of the CAN message.

Solenoid control

Based on set point and spool position, the microcontroller performs a closed loop control at a fixed frequency controlling the solenoid bridge.

Position reporting

The PVED-CX4 sends, when operating as a system configured module, continued spool position reports. This is intended as information for comparison for the application controller and the neighbor module

CAN: Spool position is calculated and broadcasted on the CAN bus with redundant representation of data. Spool position is reported as blocked when closer to neutral than approx. 0.7 mm. Spool position is reported as not blocked when further from neutral than approx. 0.7 mm. When the spool is further from neutral than software dead-band threshold the spool position is calculated as an averaged value over the last 50 ms.

Analogue: Spool position is sent as an analogue signal to neighbor microcontroller.

Neighbor supervision

The special PVED-CX4 cable kit ensures that the supervising module has the spool position from the supervised module as an analogue value and also the reported spool position via CAN bus. If supervised module is in Full Operational mode the set point from the controller is also known.

The neighbor microcontroller compares the analogue and the CAN spool position values. In Full Operational Mode the spool position is also compared to the set point. Any deviation will raise an error.

Spool monitoring in PVG, see [Cable kit principle](#).

Microcontroller supervision

The twomicrocontrollers have mutual watch dog functionality with one microcontroller giving redundant ability to shut down the neighbor microcontroller. The microcontroller can also shut down CAN communication.

The microcontroller that feeds the signal for the LVDT is monitored by the neighbor microcontroller.

Temperature supervision

The temperature of the electronic printed circuit board (PCB) is continuously monitored. This has two purposes:

- Calculated expected system reaction time must reflect temperature changes in oil viscosity.
- Component temperature conditions are within specified values.

Power save for PVED-CX4

To minimize energy consumption the PVED-CX4 has a power save functionality. If the set point for the PVED-CX4 has been blocked for more than 500ms the solenoids will be deactivated by the local switch. This reduces power consumption by 90 %.

PVED-CX4 Safety description

The Danfoss definition of safe state transition by fault is: **Spool is placed in blocked position (neutral)**. The PVED-CX4 has Active Fault Reaction, e.g. brings the system into a safe state on fault.

The PVED-CX4 safety concept is based on three elements:

- POST – Power On Self Test
- ASSIST – Automatic System Safety Integrity Test
- Runtime fault monitoring and reaction

The basic elements for product safety are:

- Continuous module monitoring
- Fault recognition and reaction
- Fault reporting and recording
- Fault recovery

POST – Power On Self Test

Passing of the Power On Self Test is a pre condition for Full Operational Mode and ASSIST.

The POST evaluates internal signals, memory state, internal settings and neighbor connection.

ASSIST – Automatic System Safety Integrity Test

The Automatic System Safety Integrity Self Test evaluates the electrical wiring connections, module inter communication, spool monitoring and hydraulic spool control.

The ASSIST is an optional test but must be passed in case of:

- First time use of PVG
- Changes in settings
- Cable kit replacement and manipulation
- Module replacement

PVED-CX4 runtime fault monitoring

The fault monitoring is a part of the continuous self and neighbor monitoring. A number of conditions will force the Device State Machine transition to fault mode. For details see sections: Data section and Error codes.

Communication fault

Communication faults interrupts application (system) and module cooperation. These faults are mainly connected to wiring faults, disabled controllers and illegal commands.

- Loss of communication
- Valid communication with invalid data
- Communication disturbance

The CAN communication is based on a physical layer applying to ISO 11898-2 high speed CAN. Faults handled by this standard are not considered relevant for this document with recovery from bus off as an exception.

Spool position fault

Spool position faults are directly related to the hydraulic performance of the application. These faults indicate difference between demanded and actual spool position.

The following categories of position faults are recognized:

PVED-CX4 Safety description

- Spool further out than demanded.
- Spool in opposite direction to demanded.
- Spool not in neutral: Target window monitoring

The spool position is determined by LVDT contact to spool end. LVDT faults are treated as electrical faults. Spool position is handled with tolerance as stated in Data section with consideration to mechanical delay and temperature influence.

System data fault

The data handling is depending on the quality of stored data and the range of input data. To avoid faults the following is monitored:

- Degradation of EEPROM.
- Degradation of FLASH.
- Sanity of look up tables
- Undefined calculations – division by 0
- Interpolation replaced by extrapolation
- Unwanted truncation
- Interrupted write process - Data mirror
- Inconsistency in spool position calculation

Electrical fault

The quality/presence of the following electrical signals is monitored to guarantee behavior within specification.

- Reciprocal watch dog signals between the two internal microprocessors
- Battery voltage in specified level
- LVDT feeder signals from microcontroller
- Analogue to digital converter ADC
- PWM (Pulse width Modulated) signal from microcontroller to neighbor microcontroller

Temperature fault and correction

Electronic component reliability and electronic component life time are influenced by temperature as well as oil viscosity is. Temperature measurements on PCB is used for

- Interrupting spool control if PCB temperature is to high
- Interrupting spool control if PCB average temperature is to high
- Delay spool monitoring time out if PCB temperature is to low
- Determine product work hours based on temperature histogram

Test fault

The PVED-CX4 has two tests with special status.

- POST. Power On Self Test for module integrity before operation.
- ASSIST. Automatic System Safety Integrity Self Test for module cooperation in control section.

Fault level

The PVED-CX4 has three fault severity levels.

PVED-CX4 Safety description

- Warning
- Critical
- Severe

Warning

Warning is entered if the fault is expected to have external origin and the PVED performance is certain not to suffer once the state is passed. Warning has no influence on neighbor modules activity.

Critical

Critical is entered if reliability of a defined element of the system could be threatened. Critical has influence on neighbor modules activity.

Severe

Severe is entered if system reliability could be threatened. Severe has influence on neighbor modules activity.

Threshold not passed

If a fault precondition is present the PVED keeps track but operates as requested until an eventual threshold is passed e.g. spool not at demanded position but only for a short time.

For every fault related to a time or occurrence threshold a counter is established.

The counter is started and reset according to a fault depending scheme.

PVED-CX4 fault reaction

The fault reaction has highest priority in the PVED-CX4. Depending on the fault the PVED immediately goes into a defined fault state. Any fault of a higher severity will override any present less severe fault.

Warning

Local switch is disabled. Solenoid valves disabled.

Spool monitoring and reporting still active. Comparison set point-actual position is disabled

Fault monitoring still active depending on operation mode.

Neighbor monitoring still active

Critical and Severe

Safety switch is disabled. Solenoid valves disabled in the whole control section.

Spool monitoring and reporting still active. Comparison set point-actual position is disabled

Fault monitoring still active depending on operation mode.

Neighbor monitoring still active

Fault reporting

Fault reporting is a part of the communication task and has lower priority than fault reaction.

CAN bus

Appropriate emergency messages are sent out according to the CANopen standard. In case of multiple errors Severe has precedence over Critical that has precedence over Warning. Errors of same severity are broadcast in order of occurrence.

Error logs

Fault is stored in an EDS log in RAM over last 50 errors using a first in first out buffer. Fault is stored in an EDS log in EEPROM showing occurrence of every fault Id. Max 255. The Error log in the EEPROM cannot be reset.

Light emitting diode

To ensure easy maintenance the PVED-CX4 utilizes the LED to indicate state of the module.

PVED-CX4 Safety description

PVED-CX4 Fault Tolerance Timing Intervals (FTTI) for Spool monitoring

Process safety time is only defined in the normal viscosity range 12 - 75 mm²/s [65 - 347 SUS]

⚠ Warning

As the safety response times are temperature dependent, reach out to your Danfoss representative, in case the application is intended to work at lower operating temperatures (i.e. <20°C) with low viscosity oil AND the application requires a Process safety time in the range of 750ms.

Temperature >=[°C]	Temperature <[°C]	Fault Detection Time [ms]	Fault Reaction Time [ms]	Safety Response Time [ms]	Process Safety Time [ms]
Temperature interval		Sum of LVDT measurement and SW timeout	Max. time it takes the spool to move to neutral, after safe state command is triggered, within the normal oil viscosity range	Max. time for fault occurring until valve is in safe state, sum of Fault Detection Time and Fault Reaction Time	Time between a failure and according safety measure to prevent a hazardous event Defined at normal oil viscosity condition
-40	-30	4250	4000	8250	not defined
-30	-20	3250	3000	6250	not defined
-20	-10	2250	2000	4250	not defined
-10	0	1750	1500	3250	not defined
0	10	1100	1000	2100	not defined
10	20	1100	500	1600	not defined
20	30	600	125	725	750
30	40	600	125	725	750
40	50	600	125	725	750
50	60	600	125	725	750
60	70	600	125	725	750
70	80	600	125	725	750
80	90	600	125	725	750
90	100	600	125	725	750
100	110	600	125	725	750
110	120	600	125	725	750
120	130	600	125	725	750

PVED-CX4 Fault Detection Time for CAN-Bus

The Fault Detection Time for CAN-Bus communication loss is 250ms. The Fault Reaction Times plus resulting Safety Response Times are temperature dependent and the same as in table above.

PVED-CX4 fault recovery

Module and system fault recovery requires that all faults have disappeared.

- Warning** Recovery is possible with software reset command.
- Critical** Recovery is possible with software reset command.
- Severe** Recovery is only possible with power cycle.

Service**PVED-CX4 maintenance**

The PVED-CX4 is designed as a non-serviceable part. In case of failure or damage, the PVED-CX4 should be replaced.

If the PVED-CX4 is dismantled or replaced, ensure no external contamination (e.g. paint, dirt, etc.) enters the hydraulic system.

No internal parts are allowed to be replaced. O-rings should be replaced when dismantling the PVED-CX4. A seal kit containing O-ring replacements can be purchased from Danfoss.

When replacing or dismantling a PVED-CX4, or if the cable harness is replaced, ASSIST test must be performed.

Decommissioning PVED-CX4

Decommissioning should be done according to local legislation.

Technical data

PVED-CX4 operational conditions

The PVED-CX4 will only operate according to this table.

Operational conditions

Mode	Supply			
	Power	CAN control	Pilot oil pressure	Oil main pressure
Electronic test. POST	Mandatory	Optional	Optional	Optional
System test. ASSIST	Mandatory	Mandatory	Mandatory	Disabled
Manual operation	Optional*	Optional*	Optional	Mandatory**
Full operation	Mandatory	Mandatory	Mandatory	Mandatory**

* Mandatory if spool position information is requested.

** If hydraulic performance is expected.

A pre-condition for electrical performance according to this technical information is interconnection of the PVED-CX4 in control sections. A control section is two to eight PVED-CX4 connected by a cable kit.

Danfoss defines safe state as spool set to blocked/neutral position.

Performance

Reaction time for actuation (@ Oil viscosity: 21 ± 0.5 cSt; Pilot pressure (P-T): 13.3 ± 0.5 bar)

Reaction time - function	Solenoids	Minimum	Maximum
From neutral to maximum spool travel	Powered	50 ms	200 ms
From maximum spool travel to neutral	Powered	-	150 ms
From power on to maximum spool travel	Powered	1000 ms	4000 ms
From maximum spool travel to neutral	Disabled	-	175 ms
Power up; from power on to CAN active	-	-	1000 ms
ASSIST run time per module	4 seconds		
Hysteresis @0.02Hz	-	0 %	1 %

Technical data

PVED-CX4 Dimensions and layout

Connector pin out

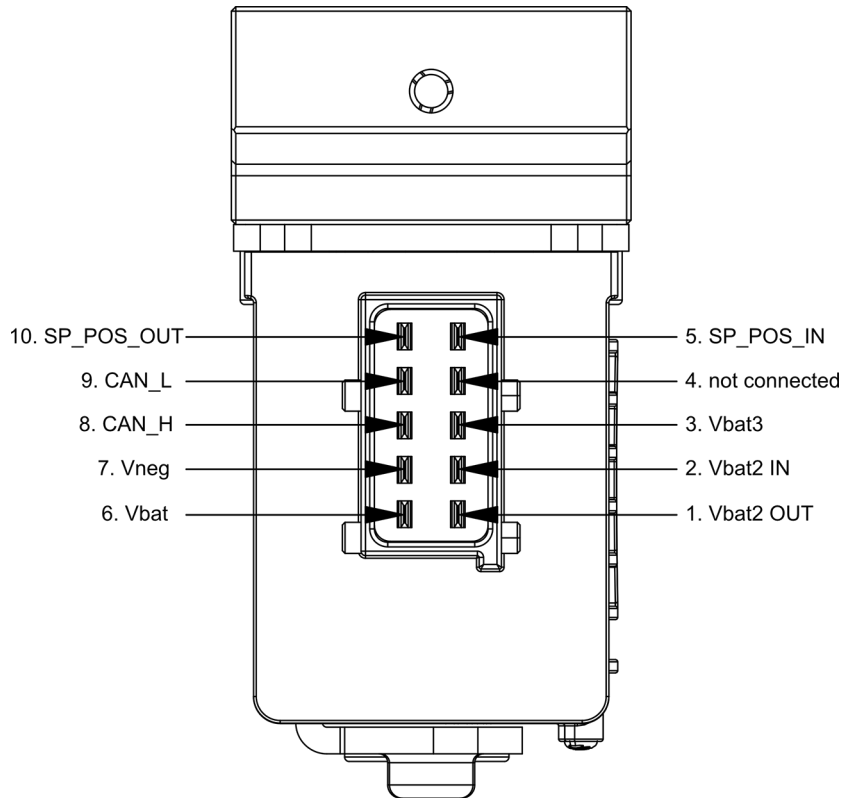

Cable dimensions

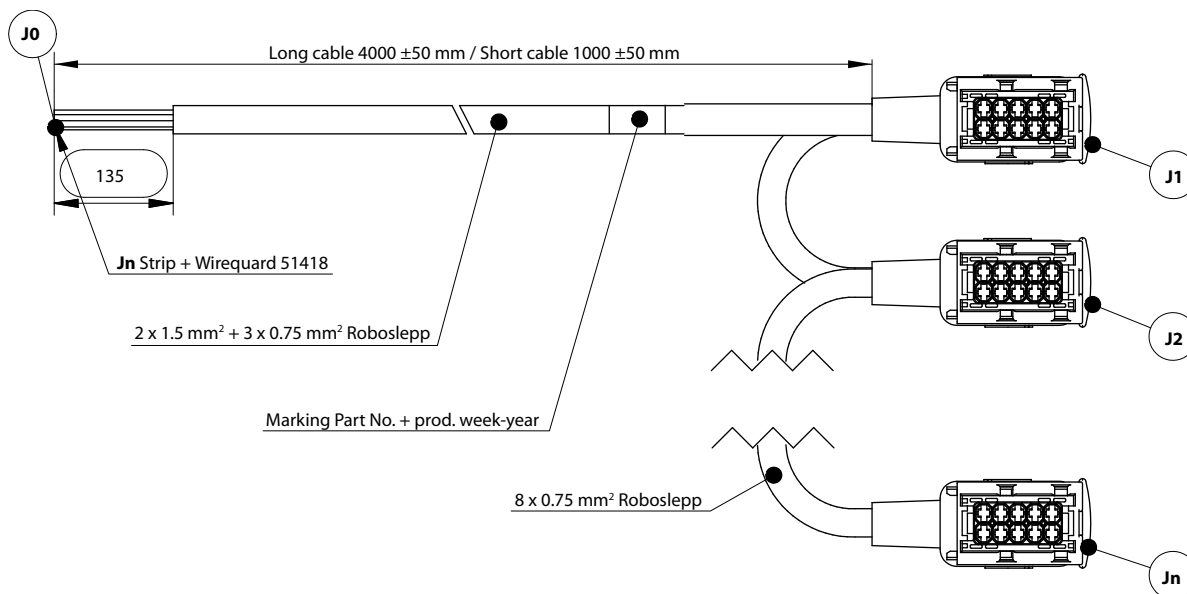

V310192.B

Long cable kit (4000 mm) is without CAN bus termination.

Short cable kit (1000 mm) is with 120 Ohm CAN bus termination in connector Jn.

Technical data

⚠ Warning

Cable is specific designed for use with PVED-CX4. When handling cable at temperature below 0°C [32°F] avoid twisting and rough handling.

Cable color codes and external connection

Description	J0 / wire ends	J1	J2	Jn
CAN low*	Yellow	9	9	9
CAN high	Orange	8	8	8
Ground	Brown	7	7	7
Vbat	Red	6	6	6
Vbat 2	Green	2	-	-

* CAN wires are only intended for communication according to ISO 11898-2.

PVED-CX4 with cable kit

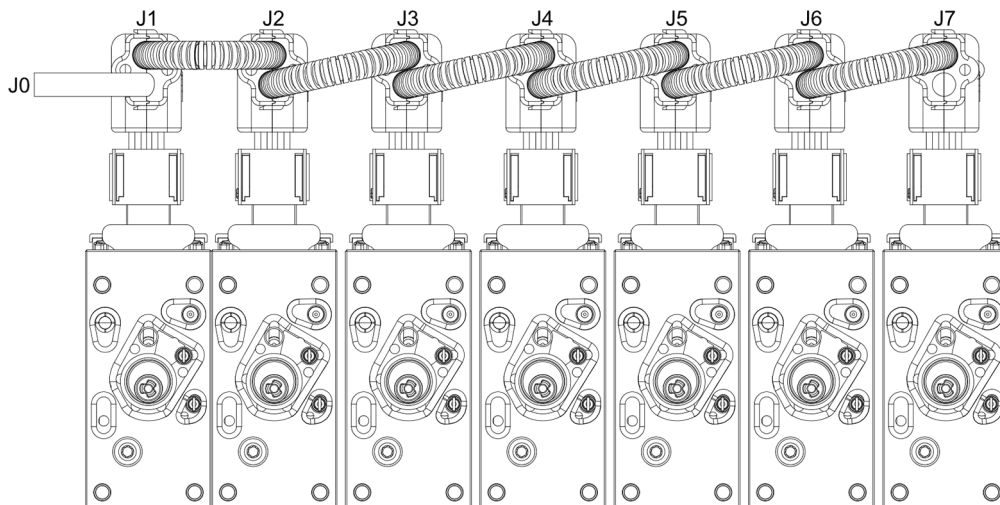

Cable can be mounted with J1 as the rightmost.

Neighbor guide

Node connector	J1	J2	J3	...	Jn
Neighbor connector	Jn	J1	J2	...	Jn-1
Example					
Node Id	20	21	22	...	26
Neighbor node Id	26	20	21	...	25

Cable kit specification

Voltage - V_{bat} , V_{bat2}	Maximum 36 V
Power	Maximum 80 W
Grade of enclosure - version with AMP JPT connector	IP 66

Technical data

Cable kit specification (continued)

Ambient temperature	Use	-30 °C → +90 °C [-22 °F → +194 °F]
	Storage	-40 °C → +100 °C [-40 °F → +212 °F]
	Recommended long time storage conditions in packaging	+10 °C → +30 °C [50 °F → +86 °F]

PVED-CX4 dimensions, mm [in]

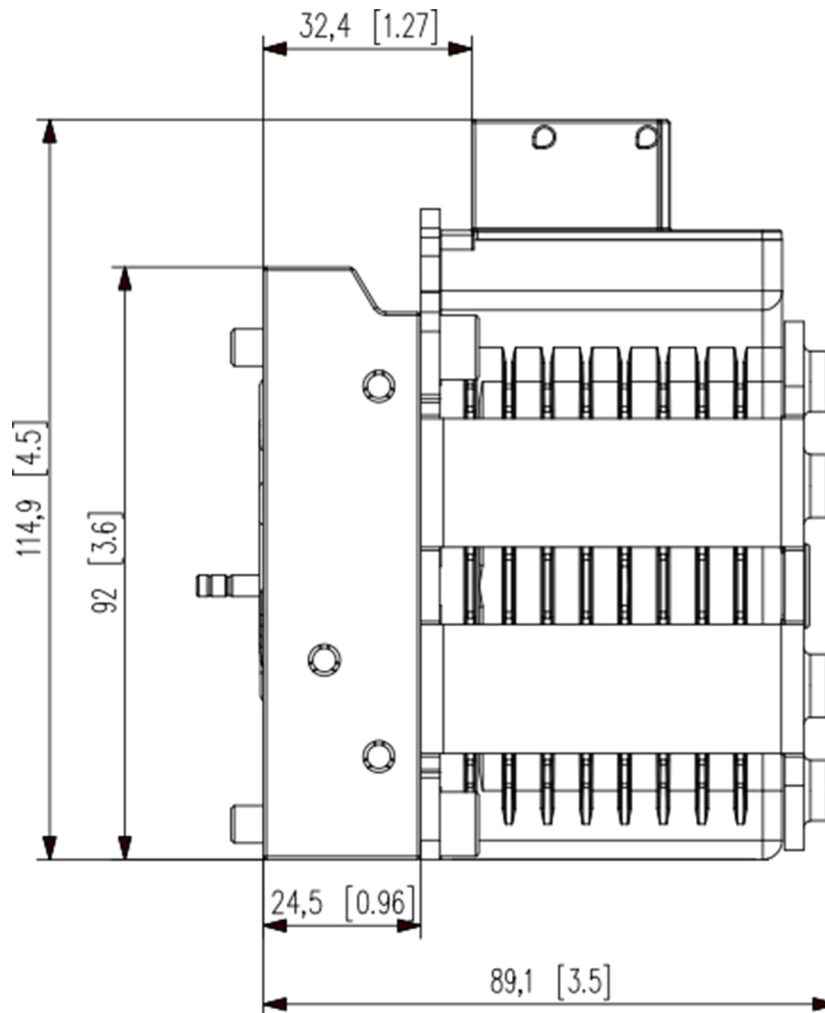

Technical data

PVED-CX4 used on PVG 32, mm [in]

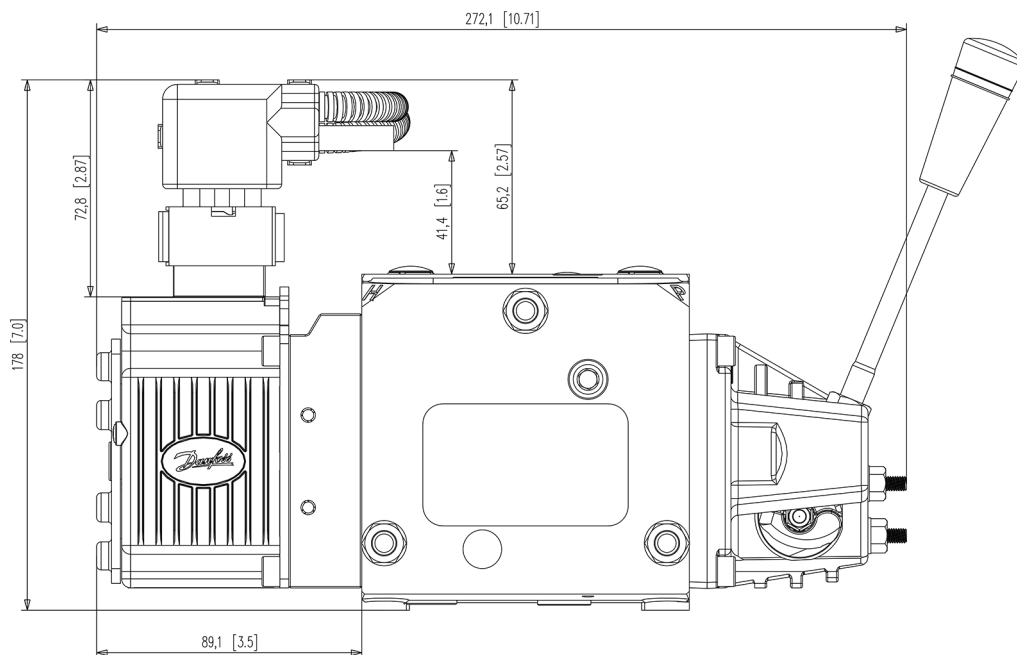

PVED-CX4 hydraulic data

Pilot oil consumption for one PVED-CX4

Solenoids depowered	0.2 - 0.4 l/min [0.05 - 0.10 US gal/min]
Spool locked by pilot oil	0.1 - 0.2 l/min [0.03 - 0.05 US gal/min]
Continuous actuation	0.9 - 1.1 l/min [0.24 - 0.29 US gal/min]
Oil viscosity: 21.0 ± 0.5 cSt, Pilot; Pilot pressure (P→T): 13.3 ± 0.5 bar	

Filtering in the hydraulic system

Required operating cleanliness level	18/16/13 (ISO 4406, 1999 version)
For further information see Danfoss documentation Hydraulic Fluids and Lubricants, Technical Information BC152886484524.	

Oil viscosity

Oil viscosity	range	12 - 75 mm ² /s [65 - 347 SUS]
	min.	4 mm ² /s [39 SUS]
	max.	460 mm ² /s [2128 SUS]

Pilot pressure

Pilot pressure (relative to T pressure)	nom.	13.5 bar [196 psi]
	min.	10.0 bar [145 psi]
	max.	15.0 bar [217 psi]

Technical data

Oil temperature

Oil temperature	range	30 - 60°C [86 - 140°F]
	min.	-30°C [-22°F]
	max.	90°C [194 °F]

Operating temperature

	Min	Max
Ambient	-30°C [-22°F]	70°C [158°F]
Stock	-40°C [-40°F]	90°C [194°F]
Recommended long time storage in packaging	10°C [50°F]	30°C [86°F]

PVP modules, pilot pressure curve

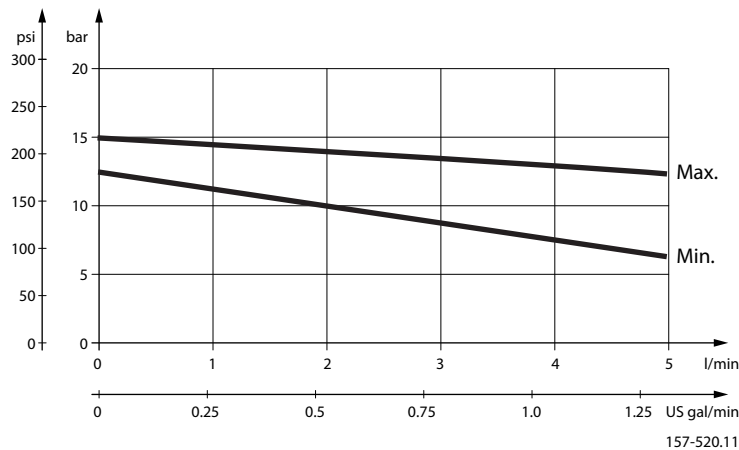

PVED-CX4 electrical data

PCB temperature

PCB temperature	range	0 - 85°C [32 - 185°F]
	min.	-30°C [-22°F]
	max average	85°C [185°F]
	max instant	100°C [212°F]

Version with AMP JPT connector

Grade of enclosure*	IP 66
---------------------	-------

* SW dead-band limit is configurable as EDS parameter.

Voltage and current

Supply voltage (DC)	
Nominal (V_{bat} and V_{bat2})	10 - 32 V
Minimum (V_{bat} and V_{bat2})	9.5 V (SW alarm 9.0 V)
Maximum (V_{bat} and V_{bat2})	33.5 V (SW alarm 35.5 V)
Max ripple	5%
Current Consumption	
Current consumption @ 12 V in Full Operational mode	750 mA

Technical data

Voltage and current (continued)

Supply voltage (DC)	
Power consumption in full operational mode	9 W
Current consumption @ 12 V in hand operational mode or power save	90 mA
Power consumption in hand operational mode or power save	1.1 W

Power consumption is independent on voltage.

Activation of solenoid valves by low voltage outside nominal is for short term exceptions, meaning maximum 10% of operating time and for max 5 minutes within an hour.

Activation of solenoid valves by 9-10 V will give reduced valve performance.

Voltage above 36 V and below 8 V will shut down electronics.

The PVED-CX4 is in conformity with the EU EMC directive 2004/108/EC and complies to the standard ISO 13766:2006 (E) Earth moving machinery – Electromagnetic compatibility.

Communication

PVED-CX4 LED

LED color interpretation

LED	Status	CAN	Vbat2	Local switch / μ C
Green	Full operational	Enabled	Enabled	Enabled
	Power save	Enabled	Enabled	Disabled
	Hand operational	Enabled	Enabled	Disabled
	Warning	Enabled	Enabled	Disabled
Orange	Fault Critical or Severe	Enabled	Disabled	Disabled
Red	Fault Severe internal handshake	Disabled	Disabled	Disabled

LED blinking interpretation

LED	Freq.	Indicates
Green	20 Hz	Spool is further out than SW-dead-band (EDS 0x6343 & EDS 0x6344) caused by a valid set point. No fault is present.
Orange	10 Hz	Fault on neighbor. Error code 0x8309, 0x830A or 0x8308. Neighbor reporting by LED has precedence over self reporting by LED. This is also happens by missing neighbor
Orange	1 Hz	Initialization of EEPROM after firmware download has ended. If the initialization process was not finalized before power off the process will restart at next boot up and then blink by finalization.

CAN

CAN data

Physical layer	ISO11898-2 high speed CAN
Protocol	ISO11783-7 / SAE J1939 (29 bit identifiers)
Baud rate	250 Kbps
Bit timing	TSEG1 = 13 TSEG2 = 4 SJW = 0 BRP = 1

According to this time quanta calculated as per data sheet is $t_q = 200$ n.s. (considering $f_{cpu} = 20$ MHz).

Technical data

Therefore:

- Before sample point [t(TSEG1)] = (TSEG1 + 1) x tq = 14 x 200 = 2800 n.s.
- After sample point [t(TSEG2)] = (TSEG2 + 1) x tq = 5 x 200 = 1000 n.s.
- t(sync-seg) = 1 x tq = 200 n.s.
- 1 Bit time = t(sync-seg) + t(TSEG1) + t(TSEG2) = 200 + 2800 + 1000 = 4000 n.s.
- One sample point at 75%.
- According to 250 kbps, 1 Bit time = 4000 n.s.

Spool control

PVED-CX4 spool positioning

- **Extend** is defined as spool moving away from PVE and equals positive values.
- **Retract** is defined as spool moving towards PVE and equals negative values.

Spool position

	-7 mm	-1.5 mm	-1.3 mm	-1.0 mm	0 mm	1.0 mm	1.3 mm	1.5 mm	7 mm
Set point	-127		-1	-	0	-	1	-	127
Feedback	-127 0x81		-1	-	0	-	1	-	127 0x7F
Oil	Oil flow		No oil flow (approx. -1.5mm to 1.5 mm)					Oil flow	
Name	Full retract	Mech dead-band	SW * dead-band	Target Window	Blocked	Target Window	SW * dead-band	Mech dead-band	Full extend
Safety	-1.0 mm Target Window 1.0 mm								
* EDS index 0x6343 sub1 and index 0x6344 sub 1.									

Closed loop

µC: Solenoid control is run at 40Hz in operation mode Full Operational.

Solenoid valve control is deactivated in power save. Monitoring is still active.

Spool monitoring, control and fault reaction

- When in blocked state a spool position further out than 1.0 mm (Target Window) is recognized as fault.
- When in flow state a spool position 0.8 mm further out than set point is recognized as fault.
- When a spool position fault is present for more than threshold time PVED enters Fault.
- Power save is entered when the set point has been Blocked/neutral for more than threshold time.
- Threshold time is defined relative to PCB temperature.

Technical data

Temperature trigger points	Time-out value (ms)	Power save and spool monitoring time out
-40	4000	<div style="text-align: center;"> <p>Temperature vs spool monitoring time-out</p> </div>
-30	3000	
-20	2000	
-10	1500	
0	1000	
10	1000	
20	500	
30	500	
40	500	
50	500	
60	500	
70	500	
80	500	
90	500	
100	500	
110	500	
120	500	

Parameter settings

Parameter setting in the PVED-CX4 is done via the Electronic Data Sheet (EDS) as described in the CANopen standard. All parameters are defined by index, sub index and value. An example of the relevant EDS file is available through your Danfoss sales representative.

Node Id

Default setting for spare part PVED-CX4 is:

- Node Id: 0xFF
- Neighbor node Id: 0xFF

A PVED-CX4 with node ID FF will not be operational and will not send a boot up message. PVED will still respond to enquire LSS address.

To operate a PVED-CX4 the Node Id and Neighbor Node Id must be values chosen from figure 26 and within same control group setting. Node Id and Neighbor Node Id must be different. Node Id and Neighbor Node Id setting is described in section Changing Node ID using LSS.

Node Id and Neighbor Node Id change will also change all COB-ID in the EDS for all read only (RO) COB-ID.

Node Id in Control sections

Ctrl sec	Node Id and neighbor node Id in group							
1	0x10*	0x11	0x12	0x13	0x14	0x15	0x16	0x17
2	0x18*	0x19	0x1A	0x1B	0x1C	0x1D	0x1E	0x1F
3	0x20*	0x21	0x22	0x23	0x24	0x25	0x26	0x27
4	0x28*	0x29	0x2A	0x2B	0x2C	0x2D	0x2E	0x2F
5	0x30*	0x31	0x32	0x33	0x34	0x35	0x36	0x37
6	0x38*	0x39	0x3A	0x3B	0x3C	0x3D	0x3E	0x3F

* Base Node-ID of section.

Technical data

Neighbor node naming guide

Connector	J1	J2	J3	...	Jn
Neighbor connector	Jn	J1	J2	...	Jn-1
Example					
Node Id	20	21	22	...	26
Neighbor node Id	26	20	21	...	25

- Connector J1 has surveillance of connector Jn e.g. PVED with J1 is programmed with Jn as neighbor.
- J0 goes to controller.
- Cable direction with ref to PVP-PVS(K) is optional.

EDS parameters – constants read only

Fixed parameters in EDS

Name	Default	Index, sub
Device type	408: proportional Hydraulic Valve	0x1000, -
COB-ID sync	Frame type 0: 11-bit ID (CAN 2.0A) 11bit SYNC-COB-ID: 128	0x1005, -
Manufacturer device name	PVED-CX4	0x1008, -
Manufacturer Hardware version	For present version: K Format - letters in order: A, ..., Z, ZA, ..., ZZ, ZZA, ...	0x1009, -
Manufacturer Software version	CANopen_R5.31	0x100A, -
Guard time	0	0x100C, -
COB-ID EMCY	Frame type 0: 11-bit ID (CAN 2.0A) 11bit COB-ID: 161	0x1014, -
Vendor Id	0x1000019	0x1018, 1
Product code	0x4317BA10 , translates to 155C4960	0x1018, 2
Revision number	0x503010 (5.31)	0x1018, 3
Serial number	e.g. 0x411ccb6f, translates to wwydxxxx*	0x1018, 4
Component ID string	157B4960N wwydxxxx (e.g. 188A7087)*	0x2201, -
Device vendor name	Danfoss	0x6057, -

* * For conversion see the section [Conversion of identity parameters to comparable values](#).

EDS parameters – variables read write

Configurable parameters in EDS

Name	Default	Range	Index, sub
Node ID	0xFF	See Spool position	
EMCY inhibit time ¹⁾	0xC8	0x64 - 0xC8, multiple of DEC 100 micro seconds	0x1015, -
Producer heart beat time ²⁾	0x0	0 if it is not used.	0x1017, -
Set point time guarding	0x64	0x0 - 0xFA	0x1400, 5
Neighbor spool position time guarding	0x64	0x0 - 0xFA	0x1402, 5
vpoc_neighbor_monitoring_additional_tolerance_in_IR ³⁾	200	0 - 1000	0x2101, -
Self TWM Timeout ⁴⁾	0xC8	0x0 - 0x1F4	0x2102, 1
Neighbor TWM Timeout	0xC8	0x0 - 0x1F4	0x2102, 2
Sync Message Event Timer ⁵⁾	0x32	0x0 - 0xFA	0x2103, -
Device description	CANopen_R5.31	Free choice of 32 ASCII	0x6053, -

Technical data

Configurable parameters in EDS (continued)

Name	Default	Range	Index, sub
Dead-band compensation A	186	100 - 1000	0x6343, 1
Dead-band compensation B	-186	(-100) - (-1000)	0x6344, 1

¹⁾ Minimum time between two EMCY published on CAN

²⁾ See "Heartbeat Messages"

³⁾ Distance between CAN position and analog position

⁴⁾ Time from blocked set point to monitoring with increased conditions

⁵⁾ Time from last SYNC to forced HOLD state

Error register. Variable read only

Error register interpretation

Bit	Mandatory / Optional	Interpretation
0	M	Generic Fault
1	O	Current
2	O	Voltage
3	O	Temperature
4	O	Communication error
5	O	Device profile specific
6	O	Reserved (always 0)
7	O	Manufacture specific

In EDS at index 1001 the present error state is given by a single byte. By any fault the setting of byte 0=1 and byte 6=0 is given.

Conversion of identity parameters to comparable values

To optimize data storage in the eds-file hexadecimal numbers, ASCII values and reverse writing is used.

Reading guide for product code and serial number

Product code and serial number is a combination of digits and letters.

The data string from the PVED-CX4, with Node Id 0x21, will give an answer to a product code enquiry in this form.

Notice product code is software part number and not sales part number.

5A1 8 43 18 10 02 10 BA 17 43

Identifier	Data Length	Product Code							
		Byte 0	Byte 1	Byte 2	Byte 3	Byte 4	Byte 5	Byte 6	Byte 7
0x580+NID	8	0x43	0x18	0x10	0x02	0x10	0xBA	0x17	0x43

Identity object byte 2 & byte 1

10 18

Sub index byte 3

2

Letter byte 7

0x43 = ASCII C

Technical data

Number byte 6 & byte 5 & byte 4

0x17BA10 = 1554960 hexadecimal to decimal

Number and letter must then be combined to 155C4960

The form of the data string from the PVED-CX4 as answer to the broadcast LSS product code enquiry broadcast.

7E4 8 5B 10 BA 17 43 00 00 00

Identifier	Data Length	Product Code							
		Byte 0	Byte 1	Byte 2	Byte 3	Byte 4	Byte 5	Byte 6	Byte 7
0x7E4	8	0x5B	0x10	0xBA	0x17	0x43	0x00	0x00	0x00

Byte reading guide

Identity object byte 0 0x5B

Letter byte 4 0x43 = ASCII C

Number byte 3 & byte 2 & byte 1

0x17BA10 = 1554960 hexadecimal to decimal

Number and letter must then be combined to 155C4960

Reading guide for numbers

The data string from the PVED-CX4, with Node Id 0x21, will give an answer to a temperature histogram value enquiry in this form.

5A1 8 43 01 23 09 E1 05 00 00

Identity object byte 2 & byte 1 23 01

Sub index byte 3 09

Number byte 7 & byte 6 & byte 5 & byte 4

0x 000005E1 = 1505 hexadecimal to decimal

Identifier	Data Length	Product Code							
		Byte 0	Byte 1	Byte 2	Byte 3	Byte 4	Byte 5	Byte 6	Byte 7
0x580+NID	8	0x43	0x01	0x23	0x09	0xE1	0x05	0x00	0x00

Error log. Variables, read only, volatile

A FIFO fault log, stored in RAM (volatile), of last 50 errors is in the EDS.

Position: Index, sub index: from 0x1003, 1 to 0x1003, 32 both included.

Error list. Variable read only

A log of occurrence count for every fault code with min 0 and max 255 is Position:

From index 0x2000 to index 0x2039 both included.

- Sub index 0: Number of entries: 5
- Sub index 1: Emergency error code: broadcast error code
- Sub index 2: Error register: error type
- Sub index 3: Occurrence counter: number of occurrences
- Sub index 4: Severity level: system reaction pattern

For further information see section Error codes.

Technical data

Instantaneous temperature. Variable read only

The current temperature is continuously measured by a dedicated circuit on the PCB.

Information is available in EDS at index 0x2300, 1

Temperature log

After every 6 minute up time the PVED-CX4 logs the current temperature. The relevant temperature interval is than counted up by one. For every temperature logging the average temperature is recalculated.

Temperature log

Interval	Limitation	Average value	Position
Interval 1	< -31 °C [$< -23.8^{\circ}\text{F}$]	-35 °C [-31°F]	0x2301, 1
Interval 2	-30 -> -21 °C [$-22 \rightarrow -5.2^{\circ}\text{F}$]	-25 °C [-13°F]	0x2301, 2
Interval 3	-20 -> -11 °C [$-4 \rightarrow -12.2^{\circ}\text{F}$]	-15 °C [5°F]	0x2301, 3
Interval 4	-10 -> -1 °C [$14 \rightarrow 30.2^{\circ}\text{F}$]	-5 °C [23°F]	0x2301, 4
Interval 5	0 -> 9 °C [$32 \rightarrow 48.2^{\circ}\text{F}$]	5 °C [41°F]	0x2301, 5
Interval 6	10 -> 19 °C [$50 \rightarrow 66.2^{\circ}\text{F}$]	15 °C [59°F]	0x2301, 6
Interval 7	20 -> 29 °C [$68 \rightarrow 84.2^{\circ}\text{F}$]	25 °C [77°F]	0x2301, 7
Interval 8	30 -> 39 °C [$86 \rightarrow 102.2^{\circ}\text{F}$]	35 °C [95°F]	0x2301, 8
Interval 9	40 -> 49 °C [$104 \rightarrow 120.2^{\circ}\text{F}$]	45 °C [113°F]	0x2301, 9
Interval 10	50 -> 59 °C [$122 \rightarrow 138.2^{\circ}\text{F}$]	55 °C [131°F]	0x2301, A
Interval 11	60 -> 69 °C [$140 \rightarrow 156.2^{\circ}\text{F}$]	65 °C [149°F]	0x2301, B
Interval 12	70 -> 79 °C [$158 \rightarrow 174.2^{\circ}\text{F}$]	75 °C [167°F]	0x2301, C
Interval 13	80 -> 89 °C [$176 \rightarrow 192.2^{\circ}\text{F}$]	85 °C [185°F]	0x2301, D
Interval 14	90 -> 99 °C [$194 \rightarrow 210.2^{\circ}\text{F}$]	95 °C [203°F]	0x2301, E
Interval 15	100 -> 109 °C [$212 \rightarrow 228.2^{\circ}\text{F}$]	105 °C [221°F]	0x2301, F
Interval 16	110 -> 119 °C [$230 \rightarrow 246.2^{\circ}\text{F}$]	115 °C [239°F]	0x2301, 10
Interval 17	> 120 °C [$> 248^{\circ}\text{F}$]	125 °C [257°F]	0x2301, 11

The average temperature can be calculated on basis of the temperature log.

Safety Switch status

The status for PVED-CX4 power supply is available in the EDS. See Figure 6. Cable kit principle.

- If Vbat2 In is supplied by more than 1.9 V reading is TRUE.
- If Vbat3 is supplied by more than 10 V reading is TRUE.

CEDS Parameters. Safety Switch

Name	Default	Range	Index, sub
Safety_Switch_Status		NA	2700
Number of entries	2	NA	2700sub0
VBAT2_IN_above_1.9V	0 (FALSE)	0 or 1	2700sub1
VBAT3_above_10V	0 (FALSE)	0 or 1	2700sub2

Technical data

Safety relevant features

Emergency msg. (EMCY)

The messages comply with Ref.3 with the extension that byte 3 of the "Manufacture specific Error Field" shows the Occurrence Counter and byte 7 gives the severity level of the relevant error.

EMCY message frame

COB-ID	Data Length	Error message							
		Byte 0	Byte 1	Byte 2	Byte 3	Byte 4	Byte 5	Byte 6	Byte 7
PVED-CX4 Node0x21									
0x0A1	8	Error Code		Error register	OC				Severity
		LSB	MSB						
... PVED-CX4 n									
0x80+NID	8	Error Code		Error register	OC				Severity
		LSB	MSB						

EMCY publishing order on CAN bus

The first active error in the system will be published on CAN bus immediately as soon as it gets activated in the system due to some fault.

In case of multiple simultaneous, e.g. more than one error within the configured EMCY Inhibit time the messages will be published in order of severity with severe first and then in order of occurrence.

EMCY Inhibit Time (Index 0x1015) is the minimum time delay in micro seconds between two consecutive EMCY messages published on CAN bus.

Reset Emergency Message

The PVED-CX4 device sends a Reset EMCY message on the CANBus for every fault whenever its get deactivated

EMCY reset frame

COB-ID	Data Length	Reset Error message							
		Byte 0	Byte 1	Byte 2	Byte 3	Byte 4	Byte 5	Byte 6	Byte 7
PVED-CX4 Node0x21									
0x0A1	4	Reset Error Code		Error register	Manufacturer Specific Error Feild				
		LSB	MSB						
... PVED-CX4 n									
0x80+NID	4	Error Code		Error register	Manufacturer Specific Error Feild				
		LSB	MSB						

Byte0 - Byte1: 16 bit EMCY Error Code

Byte2: Value of Error Register at OD-Index 0x1001

The Reset EMCY Code will be fixed for any type of fault e.g. 0x0000

PVED-CX4 device sets / resets the respective error bit of this 8 bit Error register.

Technical data

EMCY consumer behavior

The PVED-CX4 device receives EMCY message, if it is sent out by master device on CAN-bus with specified Error Code.

On receiving such EMCY from master device, the PVED-CX4 NMT state machine and DSM transit to STOPPED state and FAULT_HOLD respectively.

The EMCY message on which PVED-CX4 device is reacting as stated above is as follows:

EMCY message from Master Device

COB-ID	Data Length	Reset Error message							
		Byte 0	Byte 1	Byte 2	Byte 3	Byte 4	Byte 5	Byte 6	Byte 7
		Error Code		Error register	Manufacturer Specific Error Feild				
		LSB	MSB						
0x081	8	0x00	0x10	xx	xx	xx	xx	xx	xx

COB-ID = 0x80 + Master Device Node-ID = 0x81

Error Code = 0x10000

Byte2 to Byte7: Are don't care

NMT reset application

To reset application, e.g. deactivate all non Severe errors, reset manufacture area of object dictionary and device specific parameters to default value, a Reset Application Command is used. The frame format for Reset Application command is as follows:

Reset Application Command format

Identifier	Data Length	NMT RESET APPLICATION							
		Byte 0	Byte 1	Byte 2	Byte 3	Byte 4	Byte 5	Byte 6	Byte 7
0x000	2	Command Specifier	Node-ID	xx	xx	xx	xx	xx	xx
Ex: PVED-CX4 Node-ID = 0x20									
0x000	2	0x81	0x20						
Ex: PVED-CX4 Node-ID = 0x21									
0x000	2	0x81	0x21						

Device state:

0x81 - Reset ApplicationTo perform Reset Application Command on all PVED-CX4 modules in network 0x00 is used for "Node-ID".

This is an unconfirmed service e.g. the PVED-CX4 will not send any response.

NMT reset communication

To reset communication, e.g. deactivate all non Severe errors of communication type, a Reset Communication Command is used. The frame format for Reset Communication command is as follows:

Technical data

Reset Communication Command format

Identifier	Data Length	NMT RESET COMMUNICATION							
		Byte 0	Byte 1	Byte 2	Byte 3	Byte 4	Byte 5	Byte 6	Byte 7
0x000	2	Command Specifier	Node-ID	xx	xx	xx	xx	xx	xx
Ex: PVED-CX4 Node-ID = 0x20									
0x000	2	0x80	0x20						
Ex: PVED-CX4 Node-ID = 0x21									
0x000	2	0x80	0x21						

Device state:

0x82 - Reset Communication

To perform Reset Communication Command on all PVED-CX4 modules in network 0x00 is used for "Node-ID".

This is an unconfirmed service e.g. the PVED-CX4 will not send any response.

Reload Command

With this command the master can reload the PVED-CX4 with boot up values of all or group of parameters in non volatile memory e.g. EEPROM

Reload boot up parameters

Identifier	Data Length	Reload Parameter To EEPROM							
		Byte 0	Byte 1	Byte 2	Byte 3	Byte 4	Byte 5	Byte 6	Byte 7
COB-ID		Command Specifier	OD-Index		Sub-Index	'l'	'o'	'a'	'd'
Send reload command									
0x600+NID	8	0x22	0x11	0x10	0x01	0x6C*	0x6F	0x61	0x64
PVED-CX4 device responds with									
						Reserved			
0x580+NID	8	0x60	0x11	0x10	0x01	0x00	0x00	0x00	0x00
* ASCII 'l'									

The PVED-CX4 sends positive acknowledgement after successfully reloading

Byte0: The command specifier e.g. 0x60 indicates positive acknowledgement

COB-ID: 0x600 + Node-ID

Byte3: The sub-index will define the reload parameters.

BYTE-3	Description
0x01	RELOAD ALL PARAMETER
0x02	RELOAD COMMUNICATION PARAMETER
0x03	RELOAD APPLICATION PARAMETER
0x04	RELOAD MANUFACTURER PARAMETER

Important Points for PVED-CX4 Valve Configuration

If a valve boots up with a Node ID value outside the valid range e.g. outside {0x10, 0x3F}, then Node ID dependent COB-IDs will be initialized to 0x80000000 e.g. undefined value, and therefore no Set point

Technical data

RxPDO Mapping entry will be mapped to Set point Index at 0x3300 sub 0 and Neighbor-Set point Index at 0x2100 sub 1.

Device will stay in LSS-Init state without sending out NMT boot-up message.

Device will send out EMCY frame for CANOPEN_STACK_ERROR at boot-up, if either Node Id or Neighbor Node ID value is outside valid range at boot-up.

PVED-CX4 device does not check for Node Id and Neighbor Node Id belongs to same group, but will not be able to operate if this is the case.

Changing Node ID using Layer Setting Service

When using Layer Setting Service (LSS), it is possible to change the device Node-ID.

This service works in both of the following two ways.

- **Switch to configuration mode global method:** In this way only one PVED-CX4 device at a time can be connected to CAN-Bus for configuration.
- **Switch to configuration mode selective method:** In this way all other devices may remain connected to CAN-Bus and master selects one PVED-CX4 device among them on the basis of LSS Address for configuration.

If the LSS master device likes to switch a specific LSS slave device into LSS configuration state, the LSS master device requests a switch mode selective service with the known LSS address. The LSS address (vendor-ID, product-code, revision number, and serial number) e.g. master has the knowledge of LSS address for specific device.

If only one LSS slave device is in the network, the LSS master device may alternatively request the switch mode global service.

Step 1: Switch to configuration mode

Switch To Configuration Mode Global Way

If only one PVED-CX4 is connected to master this procedure can be used.

The transition to NMT Stopped is only required if the valve has already been configured to a valid operational Node-ID.

Switch to Configuration Mode Global Way

Identifier	Data Length	Transition to NMT stopped							
		Byte 1	Byte 2	Byte 3	Byte 4	Byte 5	Byte 6	Byte 7	Byte 8
Request Transition to NMT Stopped byte 3 to 8 are don't care:									
0x000	2	0x02	0x00						
Request (Go to LSS Global)									
7E5	8	0x04	0x01	0x00	0x00	0x00	0x00	0x00	0x00

Switch to Configuration Mode Selective Way

If more than one PVED-CX4 is connected to master this procedure must be used

Only one unconfigured PVED-CX4 must be present on the bus at a time.

All values for EDS index 0x1018 can be collected by enquire, see LSS enquire services.

It is up to master system to keep track of relation between values and node id.

Technical data

Switch to Configuration Mode Selective Way

Identifier	Data Length	LSS Switch State Selective							
		Byte 0	Byte 1	Byte 2	Byte 3	Byte 4	Byte 5	Byte 6	Byte 7
COB-ID		Command Specifier	LSS Address				Reserved		
			LSB			MSB			
Send Vendor Name, part of LSS address (Index 0x1018 sub-index 0x01)									
0x7E5	8	0x40	Vendor ID			0x00	0x00	0x00	
Send Product Name, part of LSS address (Index 0x1018 sub-index 0x02)									
0x7E5	8	0x41	Product Code			0x00	0x00	0x00	
Send Revision Number, part of LSS address (Index 0x1018 sub-index 0x03)									
0x7E5	8	0x42	Revision Number			0x00	0x00	0x00	
Send Serial Number, part of LSS address (Index 0x1018 sub-index 0x04)									
0x7E5	8	0x43	Serial Number			0x00	0x00	0x00	
PVED-CX4 device responds with									
0x7E4	8	0x44	0x00	0x00	0x00	0x00	0x00	0x00	0x00

Step-2: Configure Node ID

Configure node Id

Identifier	Data Length	Node-ID Configuration							
		Byte 0	Byte 1	Byte 2	Byte 3	Byte 4	Byte 5	Byte 6	Byte 7
COB-ID		Command Specifier	New Node-ID	Reserved					
Send New Node-ID to Device									
0x7E5	8	0x11	0x20	0x00	0x00	0x00	0x00	0x00	0x00
PVED-CX4 device responds with									
0x7E4	8	0x11	0x00	0x00	0x00	0x00	0x00	0x00	0x00

In response, data byte 1 to 2 represents error code. A non zero value indicates an error while configuring the Node-ID.

Step-3: Store New Assigned Node-ID

The device will store the newly configured Node-ID in its non volatile memory on receiving store command as per following frame format:

Store Node Id

Identifier	Data Length	Store Node ID							
		Byte 0	Byte 1	Byte 2	Byte 3	Byte 4	Byte 5	Byte 6	Byte 7
COB-ID		Command Specifier	Reserved						
Store Node-ID to device									
0x7E5	8	0x17	0x00	0x00	0x00	0x00	0x00	0x00	0x00
PVED-CX4 device responds with									
0x7E4	8	0x17	0x00	0x00	Reserved				

Technical data

In response, data byte 1 to 2 represents error code. If they are having non zero value it indicates an error while storing the Node-ID of the device.

Step-4: Switch to Normal Mode

Once new Node-ID is configured and stored in the device the system master has to perform command to come out of configuration mode as per following frame format:

Switch to normal mode

Identifier	Data Length	Switch to normal mode							
		Byte 0	Byte 1	Byte 2	Byte 3	Byte 4	Byte 5	Byte 6	Byte 7
COB-ID		Command Specifier	switch Mode	Reserved					
Request transition to normal mode									
0x7E5	8	0x04	0x01	0x00	0x00	0x00	0x00	0x00	0x00
PVED-CX4 device responds with Boot-Up Msg on New Node-ID									
0x720	8	0x00	0x00	0x00	0x00	0x00	0x00	0x00	0x00

LSS Enquiry Services

Using these services master is able to know device's LSS address and Node-ID

Before performing any of these command/s master device is expected to change the mode of device from normal to configuration e.g. Enquiry services are responded by device only in configuration mode. Use Switch to configuration mode global way.

The following information is available:

- Vendor-ID
- Product Code
- Revision Number
- Serial Number
- Node Id

Enquire can be performed in any order e.g. these commands are independent of each other.

Enquire Vendor-ID Command

This operation identifies a Danfoss product according to CAN in Automation.

Enquire Vendor-ID

Identifier	Data Length	Enquiry Service: Vendor-ID							
		Byte 0	Byte 1	Byte 2	Byte 3	Byte 4	Byte 5	Byte 6	Byte 7
COB-ID		Command Specifier	Reserved						
0x7E5	8	0x5A	0x00	0x00	0x00	0x00	0x00	0x00	0x00
PVED-CX4 device responds with Boot-Up Msg on New Node-ID									
			Vendor-ID (LSB --->MSB)				Reserved		
0x7E4	8	0x5A	0x19	0x00	0x00	0x01	0x00	0x00	0x00

Enquire Product Code Command

This information gives the software product code for the device.

Technical data

Enquire Product Code

Identifier	Data Length	Enquiry Service: Product Code							
		Byte 0	Byte 1	Byte 2	Byte 3	Byte 4	Byte 5	Byte 6	Byte 7
COB-ID		Command Specifier	Reserved						
Send									
0x7E5	8	0x5B	0x00	0x00	0x00	0x00	0x00	0x00	0x00
PVED-CX4 device responds									
			Product Code (LSB --->MSB)				Reserved		
0x7E4	8	0x5B	0xA2	0xF9	0x17	0x42	0x00	0x00	0x00

Enquire Revision Number Command

This information gives the revision number of software for the device.

Enquire Revision Number

Identifier	Data Length	Enquiry Service: Revision Number							
		Byte 0	Byte 1	Byte 2	Byte 3	Byte 4	Byte 5	Byte 6	Byte 7
COB-ID		Command Specifier	Reserved						
0x7E5	8	0x5C	0x00	0x00	0x00	0x00	0x00	0x00	0x00
PVED-CX4 device responds with									
			Revision Number (LSB --->MSB)				Reserved		
0x7E4	8	0x5C	0x05	0x03	0x01	0x00	0x00	0x00	0x00
For revision 5.31.									

Enquire Serial Number Command

This information gives the production serial number for the device.

Enquire Serial Number

Identifier	Data Length	Enquiry Service: Serial Number							
		Byte 0	Byte 1	Byte 2	Byte 3	Byte 4	Byte 5	Byte 6	Byte 7
COB-ID		Command Specifier	Reserved						
0x7E5	8	0x5D	0x00	0x00	0x00	0x00	0x00	0x00	0x00
PVED-CX4 device responds with									
			Revision Number(LSB --->MSB)				Reserved		
0x7E4	8	0x5D	0x39	0xFD	0x13	0x44	0x00	0x00	0x00
For 131D0009 (W:13, Y:1, D:Thursday, SN:0009)									

Technical data

Enquire Device Node-ID Command

Enquire Device Node-ID

Identifier	Data Length	Enquiry Service: Node-ID							
		Byte 0	Byte 1	Byte 2	Byte 3	Byte 4	Byte 5	Byte 6	Byte 7
COB-ID		Command Specifier	Reserved						
0x7E5	8	0x5E	0x00	0x00	0x00	0x00	0x00	0x00	0x00
PVED-CX4 device responds with									
			Node-ID	Reserved					
0x7E4	8	0x5E	0x20	0x00	0x00	0x00	0x00	0x00	0x00

EDS access by SDO

Set EDS parameter

Set EDS parameter

Identifier	Data Length	Setting of EDS parameter							
		Byte 0	Byte 1	Byte 2	Byte 3	Byte 4	Byte 5	Byte 6	Byte 7
0x600+NID	8	0x22	I LSB	I MSB	SUB I	0xP 1	0xP 2	0xP 3	0xP 4
Device responds with									
0x580+NID	8	0x60	I LSB	I MSB	SUB I	0x00	0x00	0x00	0x00
Send									
Identifier	Data Length	Save Parameter To EEPROM							
		Byte 0	Byte 1	Byte 2	Byte 3	Byte 4	Byte 5	Byte 6	Byte 7
COB-ID		Cmd-Specifier	OD-Index	Sub-Index	's'	'a'	'v'	'e'	
Send									
0x600+NID	8	0x22	0x10	0x10	0x01	0x73	0x61	0x76	0x65
PVED-CX4 device responds with									
0x580+NID	8	0x60	0x10	0x10	0x01	0x00	0x00	0x00	0x00
I LSB: EDS index LSB; I MSB: EDS index MSB; SUB I: EDS sub index P 1: Parameter byte LSB; P 2: Parameter byte more significant byte; P 3: Parameter byte even more significant byte; P 4: Parameter byte MSB									

Set NNI example

Set NNI example

Identifier	Data Length	Setting of neighbor node Id (0xYY) for node 0xNN							
		Byte 0	Byte 1	Byte 2	Byte 3	Byte 4	Byte 5	Byte 6	Byte 7
Request (PVED-CX4 with ID 0xNID to monitor valve with ID 0xYY)									
0x600+NID	8	0x22	0x00	0x30	0x00	0xYY	0x00	0x00	0x00
PVED-CX4 device responds with									
0x580+NID	8	0x60	0x00	0x30	0x00	0x00	0x00	0x00	0x00
Send									
Identifier	Data Length	Save Parameter To EEPROM							
		Byte 0	Byte 1	Byte 2	Byte 3	Byte 4	Byte 5	Byte 6	Byte 7

Technical data

Set NNI example (continued)

Identifier	Data Length	Setting of neighbor node Id (0xYY) for node 0xNN							
		Byte 0	Byte 1	Byte 2	Byte 3	Byte 4	Byte 5	Byte 6	Byte 7
COB-ID		Cmd-Specifier	OD-Index		Sub-Index	's'	'a'	'v'	'e'
Send save command									
0x600+NID	8	0x22	0x10	0x10	0x01	0x73	0x61	0x76	0x65
PVED-CX4 device responds with									
0x580+NID	8	0x60	0x10	0x10	0x01	0x00	0x00	0x00	0x00

Enquire EDS parameter

Enquire EDS parameters

Identifier	Data Length	Request ID YY for the node that node NN is monitoring							
		Byte 0	Byte 1	Byte 2	Byte 3	Byte 4	Byte 5	Byte 6	Byte 7
COB-ID		Cmd-Specifier	OD-Index		Sub-Index				
Send request									
0x600+NID	8	0x40	I LSB	I MSB	SUB I	0x00	0x00	0x00	0x00
PVED-CX4 device responds with									
0x580+NID	8	0xnn	I LSB	I MSB	SUB I	0xP 1	0xP 2	0xP 3	0xP 4
I LSB: EDS index LSB I MSB: EDS index MSB SUB I: EDS sub index 0xnn: the general CMD specifier					P 1: Parameter byte LSB P 2: Parameter byte more significant byte P 3: Parameter byte even more significant byte P 4: Parameter byte MSB				

Enquire NNI example

Enquire NNI example

Identifier	Data Length	Request ID YY for the node that node NN is monitoring							
		Byte 0	Byte 1	Byte 2	Byte 3	Byte 4	Byte 5	Byte 6	Byte 7
COB-ID		Cmd-Specifier	OD-Index						
0x600+NID	8	0x40	0x00	0x30	0x00	0x00	0x00	0x00	0x00
PVED-CX4 device responds with									
0x580+NID	8	0xCS	0x00	0x30	0x00	0xNNI	0x00	0x00	0x00
Data Byte (0) Command Specifier should be other than 0x80 for positive acknowledgement from device Data Byte (4): Neighbor-Node-ID									

Enquire error log example

Enquire error log example

Identifier	Data Length	Request error log							
		Byte 0	Byte 1	Byte 2	Byte 3	Byte 4	Byte 5	Byte 6	Byte 7
COB-ID		Cmd-Specifier	OD-Index		Sub-Index				
Send request for error code id									
0x600+NID	8	0x40	0xRR	0x20	0x01	0x00	0x00	0x00	0x00
PVED-CX4 device responds with									

Technical data

Enquire error log example (continued)

Identifier	Data Length	Request error log							
		Byte 0	Byte 1	Byte 2	Byte 3	Byte 4	Byte 5	Byte 6	Byte 7
0x580+NID	8	0x4F	0xRR	0x20	0x01	0xError code Id LSB	0xError code Id	0xError code Id	0xError code Id MSB
Send request for occurrences									
0x600+NID	8	0x40	0xRR	0x20	0x03	0x00	0x00	0x00	0x00
PVED-CX4 device responds with									
0x580+NID	8	0x4F	0xRR	0x20	0x03	0xcount LSB	0xcount	0xcount	0xcount MSB
RR is the LSB in the EDS index. RR [0x00 ; 0x39]. The error log has 58 posts. Sequence must be repeated for all value [0x00 ; 0x39]. Number of occurrences (0xcount) must be handled as described in section XXX.									

Valve operation

Normal Operation

The following gives description for operating a configured PVED-CX4:

NMT boot up object

The PVED-CX4 sends out a message at boot up with the Node ID.

NMT boot up - address claim

Identifier	Data Length	NMT Boot-Up Msg							
		Byte 0	Byte 1	Byte 2	Byte 3	Byte 4	Byte 5	Byte 6	Byte 7
Ex: PVED-CX4 Node-ID = 0x20									
0x720	1	0x00							
Ex: PVED-CX4 Node-ID = 0x21									
0x721	1	0x00							
... PVED-CX4 n									
0x700+NID	1	0x00							

“Address Claim” messages according to the CANopen protocol.

The NMT msg. is present on the CAN-BUS approximately 1 sec. after power on.

Heartbeat Message

Heartbeat Messages are cyclic messages which are transmitted by the PVED-CX4 as defined at OD Index 0x1017.

The messages give the NMT state of the module.

The PVED-CX4 starts sending the heartbeat messages as soon as the Heartbeat producer is configured with period not equal to Zero. The heartbeat value is number of 10ms between transmission.

Technical data

Heartbeat Message from PVED-CX4

Identifier	Data Length	HEART BEAT MSGS							
		Byte 0	Byte 1	Byte 2	Byte 3	Byte 4	Byte 5	Byte 6	Byte 7
		NMT STATE	xx	xx	xx	xx	xx	xx	xx
Ex: PVED-CX4 Node-ID = 0x20									
0x720	1	0x00							
Ex: PVED-CX4 Node-ID = 0x21									
0x721	1	0x00							
...									
Ex: PVED-CX4 Node-ID n									
0x700+NID	1	0x00							

Byte 0	NMT State
0x00	Boot up
0x04	Stopped
0x05	Operational
0x7F	Pre-Operational

Getting to Device Mode Active

Before it will be possible to send set point commands to the PVED-CX4, it is necessary to force each PVED-CX4 through a state machine into a final state called "Device Mode Active". The following sequence describes the CAN-communication, which is necessary to lead a PVED-CX4 through the state machine and into "Device Mode Active" and next is shown how a whole control section is commanded into "Device Mode Active"

PVED-CX4 node 0x21

Setting PVED 0x21 in device mode active

Identifier	Data Length	Getting PVED-CX4 1 into "Operation State"							
		Byte 1	Byte 2	Byte 3	Byte 4	Byte 5	Byte 6	Byte 7	Byte 8
0x000	2	0x01	0x21						
20 ms (Disable)									
0x621	8	0x22	0x40	0x60	0x00	0x09	0x00	0x00	0x00
The PVED-CX4 responds									
0x5A1	8	0x60	0x40	0x60	0x00	0x00	0x00	0x00	0x00
20 ms (Hold)									
0x621	8	0x22	0x40	0x60	0x00	0x0B	0x00	0x00	0x00
The PVED-CX4 responds									
0x5A1	8	0x60	0x40	0x60	0x00	0x00	0x00	0x00	0x00
20 ms (Full Operational Mode)									
0x621	8	0x22	0x42	0x60	0x00	0x01	0x00	0x00	0x00
The PVED-CX4 responds									
0x5A1	8	0x60	0x42	0x60	0x00	0x00	0x00	0x00	0x00
20 ms (Active)									
0x621	8	0x22	0x40	0x60	0x00	0x0F	0x00	0x00	0x00

Technical data

Setting PVED 0x21 in device mode active (continued)

Identifier	Data Length	Getting PVED-CX4 1 into "Operation State"							
		Byte 1	Byte 2	Byte 3	Byte 4	Byte 5	Byte 6	Byte 7	Byte 8
The PVED-CX4 responds									
0x5A1	8	0x60	0x40	0x60	0x00	0x00	0x00	0x00	0x00
1ms .. PVED-CX4 nr. 2 1ms ..									

State

State	Index	Sub	Value
Disable	0x6040	0	0x09
Hold	0x6040	0	0x0B
Active	0x6040	0	0x0F

Acknowledge from device 0x00

Mode	Index	Sub	Value
Full operational	0x6042	0	0x01
Hand operational	0x6042	0	0x02

PVED-CX4 node NID

Setting PVED node NID in device mode active

Identifier	Data Length	Getting PVED-CX4 n into "Device Mode Active"							
		Byte 1	Byte 2	Byte 3	Byte 4	Byte 5	Byte 6	Byte 7	Byte 8
0x000	2	0x01	Node-ID						
20 ms									
0x600+NID	8	0x22	0x40	0x60	0x00	0x09	0x00	0x00	0x00
The PVED-CX4 responds									
0x580+NID	8	0x60	0x40	0x60	0x00	0x00	0x00	0x00	0x00
20 ms									
0x600+NID	8	0x22	0x40	0x60	0x00	0x0B	0x00	0x00	0x00
The PVED-CX4 responds									
0x580+NID	8	0x60	0x40	0x60	0x00	0x00	0x00	0x00	0x00
20 ms									
0x600+NID	8	0x22	0x42	0x60	0x00	0x01	0x00	0x00	0x00
The PVED-CX4 responds									
0x580+NID	8	0x60	0x42	0x60	0x00	0x00	0x00	0x00	0x00
20 ms									
0x600+NID	8	0x22	0x40	0x60	0x00	0x0F	0x00	0x00	0x00
The PVED-CX4 responds									
0x580+NID	8	0x60	0x40	0x60	0x00	0x00	0x00	0x00	0x00

Technical data

Setting a control section in Device Mode Active through PDO

Identifier	Dic	Getting Control section 1 into "Device Mode Active"							
		Byte 0	Byte 1	Byte 2	Byte 3	Byte 4	Byte 5	Byte 6	Byte 7
Send NMT Operational to all PVED-CX4 device									
0x000	2	0x01	0x00						

Device Control RPDO Msg.									
		DSM State	Mode	xx	xx	xx	xx	xx	xx
Send Disabled State									
0x300+Base NID	3	0x09	0x00	0x01					
Send Hold State									
0x300+Base NID	3	0x0B	0x00	0x01					
Send Device Mode Active State									
0x300+Base NID	3	0x0F	0x00	0x01					

The control section whose state and mode is required to change can be selected by changing the identifier only.

- The identifier configuration for selecting a control section of PVED-CX4 is as follows:
- COB-ID = 0x300 + Basis Node-ID of section, see figure 28.

Set point

Time guarding on set point RxPDO messages is only active when PVED-CX4 is in 'DEVICE_MODE_ACTIVE' and in 'Full operational mode'.

The CANopen set point contains the set point to all valves in a control section. If a Node Id is not present set point should be blocked e.g. 0. The setpoint is only followed when in "Full operational mode".

Set point for Control Section

Identifier	Data Length	Set point message							
		Byte 0	Byte 1	Byte 2	Byte 3	Byte 4	Byte 5	Byte 6	Byte 7
0x200 +Base NID	8	set0	set1	set2	set3	set4	set5	set6	set7

Byte 0 is set point for lowest possible node Id in the control section e.g. 0x20

Byte 7 is set point for highest possible node Id in the control section e.g. 0x27

If more than 1 control section is active an additional set point message is required.

Set point for Control Section 1

Identifier	Data Length	Set point message							
		Byte 0	Byte 1	Byte 2	Byte 3	Byte 4	Byte 5	Byte 6	Byte 7
0x210	8	set0	set1	set2	set3	set4	set5	set6	set7

Each set-point is a signed 8 byte. The interval goes from -127 (0x81) to 127 (0x7F) with neutral set-point at 0.

The Sync message:

The sync message must be transmitted from master device.

Technical data

Sync message, global

Identifier	Data Length	Sync message							
		Byte 0	Byte 1	Byte 2	Byte 3	Byte 4	Byte 5	Byte 6	Byte 7
0x80	0								
10 ms									
0x80	0								

No information in byte 0 – 7.

Transmission of PVED-CX4 Spool Pos. Messages on Sync Msg

The PVED-CX4 sends the filtered spool position on every nth sync message from the controller.

- On which nth SYNC msg device has to send its spool position depends upon its transmission type.
- The Transmission type of Spool Pos TPDO can be configured at OD index 0x1800 Sub index 02.
- For example, if the Transmission type configured is 4 Group then on receiving four consecutive SYNC Messages a synchronization slot is opened and within the span of the next four Sync. Msg. one spool position actual value will be sent.

The actual value message from valve number 1:

Actual value messages

Identifier	Data Length	Actual value							
		Byte 0	Byte 1	Byte 2	Byte 3	Byte 4	Byte 5	Byte 6	Byte 7
0x180+NID	0	Actual	Inverted						

The Actual value message is a signed 8 byte. The interval goes from -127 (0x81) to 127 (0x7F) with neutral set-point at 0. The inverted data is a bitwise inversion of the actual value.

Actual spool position – Frame format

Identifier	Dlc	Send TxPDO (Spool Pos Info)							
		Byte 0	Byte 1	Byte 2	Byte 3	Byte 4	Byte 5	Byte 6	Byte 7
Send by PVED-CX4 Node-ID 0x20									
0x1A0	2	0x00	0xFF	xx	xx	xx	xx	xx	xx
Send by PVED-CX4 Node-ID 0x11									
0x191	2	0x84	0x7B	xx	xx	xx	xx	xx	xx
Send by PVED-CX4 Node-ID 0x3D									
0x1BD	2	0x9B	0x64	xx	xx	xx	xx	xx	xx
Byte 0: Actual Spool Pos Byte 1: Inverted Spool Pos									

The SYNC message from master is expected at rate of 10 ms.
 Default value of transmission Type for these PDOs is 4.

Hand Operational Mode and Full Operational Mode configuration

Using object at index 0x6042 and sub-index 0x00 master can change the mode of device from Hand Operational to Full Operational mode or vice versa:

Technical data

Transition between Hand operational and Full operational

Identifier	Dlc	Device State "HOLD"							
		Byte 0	Byte 1	Byte 2	Byte 3	Byte 4	Byte 5	Byte 6	Byte 7
		Command Specifier	OD-Index		Sub-Index	Mode			
Send Full Operational Mode PVED-CX4 Node-ID 0x20									
0x620	8	0x22	0x42	0x60	0x00	0x01	0x00	0x00	0x00
The PVED-CX4 responds									
0x5A0	8	0x60	0x42	0x60	0x00	0x00	0x00	0x00	0x00
Send Hand Operational Mode to PVED-CX4 Node-ID 0x21									
0x621	8	0x22	0x42	0x60	0x00	0x02	0x00	0x00	0x00
The PVED-CX4 responds									
0x5A1	8	0x60	0x42	0x60	0x00	0x00	0x00	0x00	0x00
...									
...									
Send New Mode									
0x600+NID	8	0x22	0x42	0x60	0x00	MODE	0x00	0x00	0x00
The PVED-CX4 responds									
0x5An	8	0x60	0x42	0x60	0x00	0x00	0x00	0x00	0x00

Or, alternatively master can change both DSM state and Mode by using Device control RPDOs as explained in point getting to device mode active through PDO.

Mode	Index	Sub	Value
Full operational	0x6042	0	0x01
Hand operational	0x6042	0	0x02

ASSIST

ASSIST is used for test of the electrical wiring, spool monitoring and spool control. An ASSIST will test every device in a control section individually and automatically. An ASSIST can only be performed on an entire control section.

To perform ASSIST a group of commands is required to be followed in a given order:

1. ASSIST Pre-Trigger
2. NMT Reset Application
3. ASSIST Run Command

If ASSIST is completed successfully a completion message will be sent by first tested device. ASSIST can be canceled by master device by an ASSIST Cancel Command. After ASSIST cancelation or successful completion of ASSIST a Reset Application command is required.

ASSIST Pre-Trigger Command

To start ASSIST master device must send a Pre-Trigger ASSIST command which will indicate to PVED-CX4 devices in the control section that they need to perform ASSIST.

The frame format for ASSIST Pre-trigger command is as follows:

Technical data

ASSIST Pre-trigger command

Identifier	Data Length	ASSIST Pre-Trigger Cmd							
		Byte 0	Byte 1	Byte 2	Byte 3	Byte 4	Byte 5	Byte 6	Byte 7
		Device ID	Group Num	Cmd Type	Other info	xx	xx	xx	xx
Send ASSIST Pre-Trigger command to control section 1									
0x281	4	0x01	0x00	0x01	0x00				
Send ASSIST Pre-Trigger command to control section 2									
0x281	4	0x01	0x01	0x01	0x00				
...									
Send ASSIST Pre-Trigger command to control section n									
0x281	4	0x01	0x(n-1)	0x01	0x00				

ASSIST Run Command

After receiving ASSIST Pre-Trigger and subsequently followed by NMT reset application PVED-CX4 devices are ready to perform ASSIST and waiting for ASSIST Run command from master.

The frame format for this command is as follows:

ASSIST run command

Identifier	Data Length	ASSIST run Cmd							
		Byte 0	Byte 1	Byte 2	Byte 3	Byte 4	Byte 5	Byte 6	Byte 7
		Device ID	Group Num	Cmd Type	Node-ID	xx	xx	xx	xx
Send ASSIST Run command to Node 0x10 in control section 1 to start ASSIST first									
0x281	4	0x01	0x00	0x02	0x10				

In byte-3 (Node-ID) any PVED-CX4 in the control section can be set as first device for starting the ASSIST.

Byte-0 (Device ID) indicates that on network this command is meant for PVED-CX4 devices.

- After, receiving the ASSIST run command the byte 3 PVED-CX4 will start performing the ASSIST and the other devices in the control section will turn to listening mode.
- A device performing ASSIST will send ASSIST related messages for various stages completed by device in ASSIST.
- On the completion of ASSIST for one device the device having it as neighbor will take over. When first device receive ASSIST completed from its neighbor it will acknowledge for the whole control section.

The Message-ID used by device for communicating ASSIST related messages on CAN-Bus is as follows:
 COB-ID: 0x290 + Node-ID

For example, if Node-ID = 0x10 and is performing ASSIST then it will send the response on Msg-ID = 0x2A0 and so on followed by other devices in control section.

The response messages from device having Node-ID 0x10 while performing ASSIST are as follows:

Device ASSIST step confirmation

Identifier	Data Length	ASSIST Step confirmation by PVED-CX4							
		Byte 0	Byte 1	Byte 2	Byte 3	Byte 4	Byte 5	Byte 6	Byte 7
COB-ID		Cmd Type	Info	xx	xx	xx	xx	xx	xx
ASSIST Started Msg by Node 0x10									
0x2A0	2	0x01	0x00						
ASSIST Step completion Msg by Node 0x10: (After completing step-1) Steer out in A side									

Technical data

Device ASSIST step confirmation (continued)

Identifier	Data Length	ASSIST Step confirmation by PVED-CX4							
		Byte 0	Byte 1	Byte 2	Byte 3	Byte 4	Byte 5	Byte 6	Byte 7
COB-ID		Cmd Type	Step	xx	xx	xx	xx	xx	xx
0x2A0	2	0x02	0x00						
ASSIST Step completion Msg by Node 0x10: (After completing step-2) Return to neutral									
COB-ID		Cmd Type	Step	xx	xx	xx	xx	xx	xx
0x2A0	2	0x02	0x01						
ASSIST Step completion Msg by Node 0x10: (After completing step-3) Steer in B side									
COB-ID		Cmd Type	Step	xx	xx	xx	xx	xx	xx
0x2A0	2	0x02	0x02						
ASSIST Step completion Msg by Node 0x10: (After completing step-4) Return to neutral									
COB-ID		Cmd Type	Step	xx	xx	xx	xx	xx	xx
0x2A0	2	0x02	0x03						

During ASSIST devices will send their TxPDO on their own e.g. without SYNC message and master is not required to send SYNC message while performing ASSIST.

This message indicates that ASSIST is performed successfully on entire control section.

ASSIST successfully completed

Identifier	Data Length	ASSIST completed by control section							
		Byte 0	Byte 1	Byte 2	Byte 3	Byte 4	Byte 5	Byte 6	Byte 7
COB-ID		Node-ID	ASSIST Result	Info	xx	xx	xx	xx	xx
ASSIST completed Msg by Node 0x10									
0x282	3	0x10	0xFF	0x00					

LED by ASSIST

During ASSIST the LED will flash to indicate the current state of the test.

Example with 4 PVED-CX4:

- #2 monitors #1
- #3 monitors #2
- #4 monitors #3
- #1 monitors #4

Test Sequence and operator feedback

Module activity	LED status of PVED-CX4			
	#1	#2	#3	#4
Normal operation mode	=====	=====	=====	=====
ASSIST started	G	G	G	G
#1 fault injection A-port	GGGG	GGGG	G	G
#2 detect faults	GGGG	YYYY	G	G
#2 releases vbat_2	GGGG	GGGG	G	G
#1 fault injection B-port	GGGG	GGGG	G	G

Technical data

Test Sequence and operator feedback (continued)

Module activity	LED status of PVED-CX4			
	#1	#2	#3	#4
#2 detect faults	GGGG	YYYY	G	G
#2 releases vbat_2	GGGG	GGGG	G	G
#2 fault injection A-port	G	GGGG	GGGG	G
#3 detect faults	G	GGGG	YYYY	G
#3 releases vbat_2	G	GGGG	GGGG	G
#2 fault injection B-port	G	GGGG	GGGG	G
#3 detect faults	G	GGGG	YYYY	G
#3 releases vbat_2	G	=====	GGGG	G
#3 fault injection A-port	G	=====	GGGG	GGGG
#4 detect faults	G	=====	GGGG	YYYY
#4 releases vbat_2	G	=====	GGGG	GGGG
#3 fault injection B-port	G	=====	GGGG	GGGG
#4 detect faults	G	=====	GGGG	YYYY
#4 releases vbat_2	G	=====	=====	GGGG
#4 fault injection A-port	GGGG	=====	=====	GGGG
#1 detect faults	YYYY	=====	=====	GGGG
#1 releases vbat_2	GGGG	=====	=====	GGGG
#4 fault injection B-port	GGGG	=====	=====	GGGG
#1 detect faults	YYYY	=====	=====	GGGG
#1 releases vbat_2	=====	=====	=====	=====

Legend:

===== constant green light

G green flash (1 Hz)

GGGG green flash (4 Hz)

YYYY yellow flash (4 Hz)

CANCEL ASSIST Command

ASSIST can be canceled while the test is performed by control section by using this command. The ASSIST cancellation must be sent to the same node as the ASSIST run command was sent to.

PVED-CX4 will on reception suspend the ASSIST and go into Safe State, e.g. DSM state changes to DISABLED State.

Frame Format for CANCEL ASSIST command:

ASSIST cancellation

Identifier	Data Length	ASSIST cancellation by master							
		Byte 0	Byte 1	Byte 2	Byte 3	Byte 4	Byte 5	Byte 6	Byte 7
COB-ID		Node-ID	Group Num	Cmd type	Info	xx	xx	xx	xx
Send ASSIST cancellation									
0x281	4	0x10	0x01	0x00	0x00				

Technical data

ASSIST Abort Message

PVED-CX4 device will abort and send ASSIST Abort message on the CAN bus if any problem fault is detected during test along with failure error code in message.

The frame format is as follows:

ASSIST aborted

Identifier	Data Length	ASSIST canceled by PVED-CX4							
		Byte 0	Byte 1	Byte 2	Byte 3	Byte 4	Byte 5	Byte 6	Byte 7
COB-ID		Node-ID	ASSIST Result	Err Code	xx	xx	xx	xx	xx
ASSIST aborted Msg by Node 0x12									
0x282	3	0x12	0x00	0x2B					

The above message indicates that ASSIST is aborted by node 0x12 in control section with error code 0x2B. On reception of ASSIST aborted all PVED-CX4 in the control section transits to disabled state.

State machine

Important points about PVED-CX4 DSM Implementation

Device State Machine (DSM)

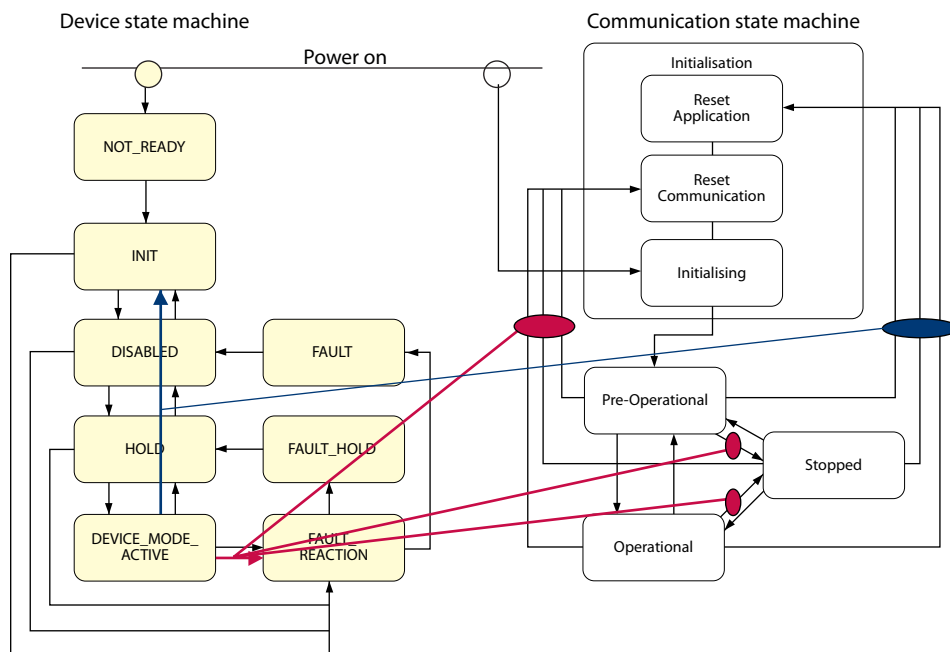

V310034.A

INIT state:

Module enters the INIT state after basic initialization related to communication system and goes into 'pre-operational' mode.

- Safety Switch: Disabled
- μ C solenoid driver circuit: Disabled
- Time-Guarding on RPDOs is Disabled
- PVED-CX4 does not send Actual value PDO.
- PVED-CX4 does NOT control spool.
- Comparisons of self Set Point and actual value is Enabled
- Neighbor Monitoring is Enabled

DISABLED state:

Pre-requisite for entering this state is that Communication state machine should be in 'Operational' state. This is a 'Safe state'

- Safety Switch: Disabled
- ASIC solenoid driver circuit: Disabled
- Time-Guarding on Actual Neighbor value RPDO and Set Points RPDO is Disabled
- PVED-CX4 sends Actual value PDO.
- PVED-CX4 does NOT control spool.
- Comparisons of self Set Point and actual value is Enabled

HOLD state:

In this state Master has write access to index 0x6042 (DEVICE_MODE) via SDO messages

State machine

Master can change DEVICE_MODE of the valve to either ASSIST mode, Hand Operational mode or Full Operational mode.

- Safety Switch Enabled
- μ C solenoid driver circuit: Disabled
- Time-Guarding on Neighbor Actual Value RPDO is Enabled
- Time-Guarding on Master Set Point RPDO is Disabled
- PVED-CX4 sends out Actual value PDO.
- PVED-CX4 does NOT control spool.
- Comparisons of Set Point and actual value is Enabled.
- Comparisons of Analog and Digital Actual values of Neighboring valve is either Disabled (Hand Operational Mode) or Enabled (Full Operational Mode).
- Comparisons of Neighbor Set Point and Neighbor Actual value (Digital) are either Disabled (Hand Operational Mode) or Enabled (Full Operational Mode), depending upon selected 'Device Mode'.

DEVICE_MODE_ACTIVE state:

Write access to index 0x6042 via SDO is NOT allowed in this state. Module will be in mode set in Hold State

Hand Operational Mode

- Safety Switch: Enabled
- μ C solenoid driver circuit: Disabled
- Time-Guarding on Neighbor Actual Value RPDO is Enabled
- Time-Guarding on Set Point RPDO is Disabled
- PVED-CX4 device sends Actual value PDO.
- PVED-CX4 does NOT control spool. Lever is used to control the valve.
- Comparisons of self Set Point and actual value is Disabled
- Comparisons of Analog and Digital Actual values of Neighbor valve is Enabled
- Comparisons of Neighbor Set Point and Neighbor Actual value (Analog) is Disabled

Full Operational Mode

In this state all features are enabled.

- Safety Switch: Enabled
- μ C solenoid driver circuit: Enabled
- Time-Guarding on Neighbor Actual Value RPDO is Enabled
- Time-Guarding on Set Point RPDO is Enabled
- PVED-CX4 sends out Actual value PDO on CAN bus
- PVED-CX4 controls the spool as defined by Set Point values
- Comparisons of self Set Point and actual value is Enabled
- Comparisons of Analog and Digital Actual values from neighbor valve is Enabled
- Comparisons of Neighbor Set Point and Neighbor Actual value (Analog) is Enabled

ASSIST Mode

- Safety Switch: Enabled
- μ C solenoid driver circuit: Enabled
- Time-Guarding on Neighbor Actual Value RPDO is Enabled
- Time-Guarding on Set Point RPDO is Enabled
- PVED-CX4 communicates with control section and master.

State machine

- Valve steers out using pre programmed values
- Comparisons of set point and actual value is Enabled
- Comparisons of Analog and Digital Actual values of Neighbor module is Enabled
- Comparisons of Neighbor Set Point and Neighbor Actual value (Analog) is Enabled.

PVED-CX4 hand operational mode

- Safety Switch: Enabled
- μ C solenoid driver circuit: Disabled
- Time-Guarding on Neighbor Actual Value RPDO is Enabled
- Time-Guarding on Set Point RPDO is Disabled
- PVED-CX4 device sends Actual value PDO.
- PVED-CX4 does NOT control spool. Lever is used to control the valve.
- Comparisons of self Set Point and actual value is Disabled
- Comparisons of Analog and Digital Actual values of Neighbor valve is Enabled
- Comparisons of Neighbor Set Point and Neighbor Actual value (Analog) is Disabled

PVED-CX4 full operational mode

In this state all features are enabled.

- Safety Switch: Enabled
- μ C solenoid driver circuit: Enabled
- Time-Guarding on Neighbor Actual Value RPDO is Enabled
- Time-Guarding on Set Point RPDO is Enabled
- PVED-CX4 sends out Actual value PDO on CAN bus
- PVED-CX4 controls the spool as defined by Set Point values
- Comparisons of self Set Point and actual value is Enabled
- Comparisons of Analog and Digital Actual values from neighbor valve is Enabled
- Comparisons of Neighbor Set Point and Neighbor Actual value (Analog) is Enabled

ASSIST Mode

- Safety Switch: Enabled
- μ C solenoid driver circuit: Enabled
- Time-Guarding on Neighbor Actual Value RPDO is Enabled
- Time-Guarding on Set Point RPDO is Enabled
- PVED-CX4 communicates with control section and master.
- Valve steers out using pre-programmed values
- Comparisons of set point and actual value is Enabled
- Comparisons of Analog and Digital Actual values of Neighbor module is Enabled
- Comparisons of Neighbor Set Point and Neighbor Actual value (Analog) is Enabled.

FAULT_REACTION state:

This is an intermediate, transient state as perceived by the CANopen master and other nodes on the network. PVED-CX4 goes into this state on occurrence of any fault in the system. PVED-CX4 device immediately transits to either FAULT_HOLD or FAULT state from here.

State machine

FAULT_HOLD state:

PVED-CX4 device will get into this state when some faults of Warning type occur and no fault of type Critical or Severe are present

EMCY frame is sent

- Safety Switch: Enabled
- μ C solenoid driver circuit Disabled
- Time-Guarding on Neighbor Actual Value RPDO is Enabled
- Time-Guarding on Master Set Point RPDO is either Disabled (Hand-Operation Mode) / Enabled (Full Operational Mode), depending upon selected 'Device Mode'
- PVED-CX4 device sends out Actual value PDO
- PVED-CX4 does NOT control spool.
- Comparisons of self Set Point and actual value is Disabled
- Comparisons of Analog and Digital Actual values of Neighboring valve are either Disabled (Hand Operational Mode) or Enabled (Full Operational Mode), depending upon selected 'Device Mode'
- Comparisons of Neighbor Set Point and Neighbor Actual value (Digital) are either Disabled (Hand Operational Mode) or Enabled (Full Operational Mode), depending upon selected 'Device Mode'

FAULT state:

On occurrence of Critical or Severe type of fault in the system, PVED-CX4 device gets into this state. It sends out appropriate EMCY frame. PVED-CX4 device needs to be re-booted, in order to take it out from the FAULT state.

- Safety Switch: Disabled
- μ C solenoid driver circuit Disabled
- PVED-CX4 does NOT control spool.
- Time-Guarding on Neighbor Actual Value RPDO is Enabled
- Time-Guarding on Master Set Point RPDO is Disabled
- PVED-CX4 device sends out Actual value PDO on CAN bus
- Comparisons of self Set Point and actual value are Disabled
- Disabled Comparisons of Analog and Digital Actual values of Neighbor valve
- Comparisons of Neighbor Set Point and Neighbor Actual value (Digital) are Disabled

State Transition

When performing the transition from FAULT_HOLD to HOLD state, PVED-CX4 device checks that no errors are ACTIVE in the system. If there are any, then this transition does not take place.

Transition from FAULT state to DISABLED state has been removed and is not applicable for PVED-CX4 device

For any invalid transition that gets triggered from master, PVED-CX4 device will respond with successful SDO-Write response frame, but it will send out an EMCY frame indicating Device State Machine related error, e.g. Device Control Error and will transit to FAULT_HOLD state. Also, DeviceStatusWord at 0x6041 index won't get updated.

PVED-CX4 device needs to be in 'Operational' state, before going in to the DISABLED state from INIT state, otherwise it will be treated as invalid transition

The responses from PVED-CX4 devices for various LSS identification and enquiry services are sent on same message-ID with same data content. This could generate multiple messages on the bus with same message-ID and data content simultaneously. E.g. multiple default configured PVED-CX4 on the bus and master tries to perform 'Identify Non Configured Remote Slave service'. In such cases there could be collision on the CANbus.

State machine

It would be required for the master device to take PVED-CX4 device from INIT (after boot-up) to DEVICE_MODE_ACTIVE through DISABLED and HOLD states, so as to bring PVED-CX4 valve into 100 % functional state.

PVED-CX4 resets parameters in 'Device Specific Area', when DSM goes to INIT state. e.g. reload default values 'Device Specific parameters'. Parameter values in 'Communication' and 'Manufacturer Specific' area stays untouched.

Limitations and Known Software Issues

- The set point range is ± 127 . Using -128 to $+127$ is not recommended as this input is asymmetric.
- It is advisable to perform Save and Reload operations on the valves, when they are in DISABLED state.
- Event Timer Implementation
 - PVED-CX4 device will perform upper and lower limit correction on Event Timer values. Since, as per CANopen specifications, value range for Event Timer object is from 0 - U16Max and 0 being a special value used to disable the time guarding, it is not possible to set practical upper and lower limit values of 30 ms and 250 ms resp. to these sub-indexes for SDO operations. So, if master configures any value between 1 to 29 ms to Event Timer sub-index, it performs lower limit correction and starts performing time-guarding with a timeout value of 30 ms. Similarly, if master configures any value more than 250 ms to Event Timer sub-index, it performs upper limit correction and starts performing time-guarding with a timeout value of 250 ms.
- LSS
 - PVED-CX4 will process LSS commands only if it is in NMT STOPPED state or if it boots up with Invalid Self-NodeID value of 0xFF.
 - The LSS slave device e.g. PVED-CX4 under configuration does not have the capability to verify if other LSS slave devices are also in configuration state. This means the LSS master device is responsible for correctness and sequence of LSS service requests.
 - The response from PVED-CX4 devices for various LSS identification and enquiry Services is sent on same Msg-ID and having same data byte content This could generate multiple messages on CAN-Bus with same Msg-ID and data byte Content simultaneously. E.g. multiple default configured PVED-CX4 on bus and master tries to perform 'Identify Non Configured Remote Slave service'. In such cases, there is chance having collision on CAN-Bus.
- Device Control RxPDO -
 - If master simultaneously changes both Device Control Word as well as Device Mode values in the Device Control RxPDO, then PVED-CX4 device will accept it. PVED-CX4 device will process new Device Mode first and then it will process new Device Control Word.
 - Default PDO-map is not fully compliant with the CiA-408
 - Asynchronous cyclic transmission type is not supported by TPDOs
- PVED-CX4 device acts as EMCY consumer and handles EMCY messages sent to it on 0x81 message ID. On receiving EMCY Error Code of 0x1000 in the message with COB-ID of 0x81, PVED-CX4 device goes to NMT-STOPPED state.
- The application is designed to handle bus load greater than 90% but is advisable to operate at lower bus load up to 70 %.
- It is possible that device may lose its current SYNC slot on changing its transmission type while they are transmitting their spool position related TxPDO on CAN-Bus as they are not listening to SYNC messages any more. Once new transmission time is configured and responded successfully device will start following its new SYNC slot. It is advisable to stop SYNC messages while changing transmission type.
- Dead Band Compensation:
Master should take care while changing dead band compensation it is expected that master should not configure it below 101 and higher than 214 (approx 1.5 mm) in terms of IR.

Warnings

PVED-CX4 warnings

Warning

The use of PVED-CX4 will not guarantee a system to be SIL 2 certified as this is the responsibility of the system integrator.

An application with PVG 32 and PVED-CX4 will only have SIL classification if the whole application has been certified.

A PVG with PVED-CX4 can only perform according to its SIL classification if conditions in this Technical Information are met.

SIL 2 is only verified within the control section. Communication and interaction outside the control section is not guaranteed by this product.

In particularly exposed applications, protection in the form of a shield is recommended.

When the PVED-CX4 is in Device Modes related to fault the validity of module reporting is limited by the fault type.

Deviation from recommended torque when mounting parts can harm performance and module.

Do not adjust the position transducer (LVDT) as this will influence calibration, and thus also safety and performance. This will also be the case by any damage or partial/full fixation of the LVDT.

All brands and all types of directional control valves – including proportional valves – can fail and cause serious damage. It is therefore important to analyze all aspects of the application. Because the proportional valves are used in many different operation conditions and applications, the machine builder/ system integrator alone is responsible for making the final selection of the products – and assuring that all performance, safety and warning requirements of the application are met.

When replacing the PVE, the electrical and the hydraulic systems must be turned off and the oil pressure released.

Hydraulic oil can cause both environmental damage and personal injuries.

Module replacement can introduce contamination and errors to the system. It is important to keep the work area clean and components should be handled with care.

After replacement of modules or cables wiring quality must be verified by an ASSIST. By PVED actuation at voltage below nominal, 11V, the PVG will have reduced performance.

The PVED-CX4 is not designed for use with voltage outside nominal for more than 5 minutes per hour and maximum 10% of operating time.

By operation with PCB temperature below 0°C [32°F] the transition to fault mode due to spool monitoring is delayed.

The PVED-CX4 will go into safe state if fault conditions are present.

Obstacles for the Pilot oil can have direct influence on spool control.

Reduced pilot pressure will limit spool control. Too high pilot pressure can harm the system.

Cable is designed specifically for use with PVED-CX4. When handling cable at temperatures below 0°C [32°F] avoid twisting and rough handling.

Error codes

The following information applies to all content in this chapter.

[Error code timing values may be subject to additional delay up to 100ms prior to broadcasting due to internal cross-validation.](#)

Index 1 • Common Name: Reserved

Obj. Dict. Index 0x2000
CANopen Name Reserved
Error code ID 0xFFFF
Severity 0
Error register 0x00
Error type 0
Filtered No
Finding Reserved
Problem Reserved
Likely root cause Reserved
Counteraction Replace module
Deactivation Not available.

Index 2 • Common Name: Supply voltage too high

Obj. Dict. Index 0x2001
CANopen Name Power Supply Voltage to high
Error code ID 0x3411
Severity Warning
Error register 0x5
Error type Application
Filtered yes
Finding AD converter in PVED shows voltage on Vbat or Vbat2 above 35,5 V for more than 500ms. Is based on voltage at sample time and is controlled by a counter. Over voltage at sample time will increment counter by 1 else counter is decremented by 1. At 50 counts fault is raised.
Problem Internal calculations can suffer from wrong reference voltage
Likely root cause A: Supply voltage is above 35,5 volt.
B: Internal error in μ C
Counteraction A: Lower supply voltage below 32V.
--- By multiple reoccurrence with control measurements not showing to high supply replace module
Deactivation Module is operational when fault disappears. Fault disappears when sum of samples with voltage below 35.5V (minus samples with voltage above) is 50.

Index 3 • Supply voltage too low

Obj. Dict. Index 0x2002
CANopen Name Power supply voltage to low
Error code ID 0x3412

Error codes

Severity Warning

Error register 0x5

Error type Application

Filtered Yes

Finding AD converter in PVED shows voltage on Vbat or Vbat2 below 9 V for more than 500ms. Is based on voltage at sample time and is controlled by a counter. Under voltage at sample time will increment counter by 1 else counter will decrement by 1.

At 50 counts fault is raised.

Problem Current in module too high and gives extreme heating. Electronics can't work properly

Likely root cause A: Supply voltage is below 9 volt.

B: Internal error in μ C

Counteraction A: Adjust supply voltage above 11V.

--- By multiple reoccurrence with control measurements not showing too high supply replace module

Deactivation Module is operational when fault disappears. Same procedure as above.

Index 4 • Illegal state command

Obj. Dict. Index 0x2003

CANopen Name Device Control

Error code ID 0x5200

Severity Warning

Error register 0x21

Error type Application

Filtered No

Finding The DSM was tried to be switched into a state which is not possible due to the state machine transitions. E.g.

INIT->HOLD or FAULT->HOLD.

Another cause of this error may be a transition request from FAULT to DISABLED while an active error prevents such transition.

Problem Illegal commands violate the safety concept

Likely root cause A: A state shift was ordered by master at the same time as a safety related switch was initiated by PVED.

B: A state shift was ordered during an active error.

C: Illegal state shift command from master.

Counteraction A: Verify for illegal commands.

B: Send legal transaction.

C: Reset Application.

--- By multiple reoccurrences replace module.

Deactivation Send legal state transaction.

Index 5 • Division by zero, illegal SW operation

Obj. Dict. Index 0x2004

CANopen Name Division by zero

Error codes

Error code ID 0x6201

Severity Severe

Error register 0x81

Error type Application

Filtered No

Finding Table value or input value used for division is 0.

Problem Operation puts μ C in fault mode

Likely root cause Electrical input out of range, electrical disturbance or fault in components

Counteraction A: Reboot module.

--- By multiple reoccurrence replace module

Deactivation Cycle power

Index 6 • Internal table value corrupted, illegal SW operation

Obj. Dict. Index 0x2005

CANopen Name Demand value generation

Error code ID 0x6202

Severity Severe

Error register 0x81

Error type Application

Filtered No

Finding Internal table value for set point or calibration is out of range

Problem Calculations can not be trusted

Likely root cause Electrical disturbance or fault in components

Counteraction A: Reboot module.

--- By multiple reoccurrence replace module

Deactivation Cycle power

Index 7 • Wrong data interpretation, truncation of values

Obj. Dict. Index 0x2006

CANopen Name Variable truncation

Error code ID 0x6203

Severity Severe

Error register 0x81

Error type Application

Filtered No

Finding Calculation is giving result out of range Software error indicating that an (unintended) variable truncation happened.

Problem Calculations can not be trusted

Likely root cause Electrical disturbance or fault in components

Counteraction A: Reboot module.

--- By multiple reoccurrence replace module

Error codes

Deactivation Cycle power

Index 8 • Interpolation fault, illegal SW operation

Obj. Dict. Index 0x2007

CANopen Name Interpolation fault

Error code ID 0x6204

Severity Severe

Error register 0x81

Error type Application

Filtered No

Finding Indication that an extrapolation was used instead of interpolation or interpolation coordinates are overlapping

Problem Calculations can not be trusted

Likely root cause A: Needed values not covered by saw or parameters.

B: Electrical disturbance or fault in components

Counteraction A: Reboot module.

--- By multiple reoccurrence replace module

Deactivation Cycle power

Index 9 • No handshake to μ C

Obj. Dict. Index 0x2008

CANopen Name Supervisor handshake

Error code ID 0x6205

Severity Severe

Error register 0x81

Error type Application

Filtered No

Finding The PVED microcontroller did not get an input. Pin 3 & 4 did not recognize expected input from watch dog

Problem Calculations can not be trusted

Likely root cause Electrical disturbance or fault in components

Counteraction A: Reboot module.

--- By multiple reoccurrence replace module

Deactivation Cycle power

Index 10 • Watchdog not starting

Obj. Dict. Index 0x2009

CANopen Name Supervisor Power-On-Self-Test

Error code ID 0x6206

Severity Severe

Error register 0x81

Error codes

Error type Application

Filtered No

Finding Boot up sequence for watchdog was not recognized as correct when expected

Problem Missing confirmation that part of the safety system has started correctly

Likely root cause Electrical disturbance or fault in components. Or same firmware has been downloaded twice and then module was not rebooted fast enough.

Counteraction A: Reboot module.

--- By multiple reoccurrence replace module

Deactivation Cycle power

Index 11 • RTOS error

Obj. Dict. Index 0x200A

CANopen Name RTOS Error

Error code ID 0x6207

Severity Severe

Error register 0x81

Error type Application

Filtered No

Finding The operating system did not perform as expected. Problems by task creation, task suspension or buffer access

Problem System can not be trusted

Likely root cause Electrical disturbance or fault in components

Counteraction A: Reboot module.

--- By multiple reoccurrence replace module

Deactivation Cycle power

Index 12 • LVDT verification fault

Obj. Dict. Index 0x200B

CANopen Name Sensor module LVDT

Error code ID 0x5231

Severity Critical

Error register 0x21

Error type Application

Filtered Yes

Finding One or more of LVDT test parameters has not been detected valid for more than 500ms

Problem Spool position can not be trusted

Likely root cause LVDT forced out of position, electrical disturbance or fault in components

Counteraction A: Verify for external influence on LVDT.

B: Reset application.

--- By multiple reoccurrence replace module

Deactivation Reset application

Error codes

Index 13 • Neighbor LVDT fault

Obj. Dict. Index 0x200C
CANopen Name Sensor neighbor LVDT
Error code ID 0x5232
Severity Critical
Error register 0x21
Error type Application
Filtered No
Finding Analogue input from neighbor LVDT is not within specification
Problem Neighbor monitoring and reaction not possible
Likely root cause A: Module not connected to an active neighbor.
B: Wiring fault.
C: Neighbor is not sending valid signal.
D: Module not reading voltage.
Counteraction A: Connect to an active neighbor.
B: Check wiring for connection.
C: Connect neighbor to other module or verify output voltage.
D: Connect to other module.
Deactivation Reset application

Index 14 • Temperature sensor fault

Obj. Dict. Index 0x200D
CANopen Name Sensor: Module Temperature
Error code ID 0x5233
Severity Critical
Error register 0x21
Error type Application
Filtered No
Finding Input from temperature sensor is not seen within specification
Problem Temperature monitoring not possible
Likely root cause Electrical disturbance or fault in components
Counteraction A: Reset application.
--- By multiple reoccurrence replace module
Deactivation Reset application

Index 15 • Fault In RAM

Obj. Dict. Index 0x200E
CANopen Name RAM: boot up test
Error code ID 0x5511
Severity Severe

Error codes

Error register 0x81
Error type Application
Filtered No
Finding Test failed for iRAM and xRAM found. RAM cell is stocked at 0 or 1
Problem Calculations can not be trusted
Likely root cause Electrical disturbance or fault in components
Counteraction A: Reboot module.
--- By multiple reoccurrence replace module
Deactivation Cycle power

Index 16 • Temperature average to high

Obj. Dict. Index 0x200F
CANopen Name Average temperature of PCB is too high
Error code ID 0x4223
Severity Warning
Error register 0x9
Error type Application
Filtered No
Finding Calculation of temperature average for PCB shows to high value. Greater than 85 deg C
Problem Validity of electronic components is threatened
Likely root cause Over heating of module
Counteraction Cool module while system is powered for more than 6 minutes
Deactivation reset Application

Index 17 • Code memory check fault

Obj. Dict. Index 0x2010
CANopen Name FLASH program memory CRC16
Error code ID 0x5521
Severity Severe
Error register 0x81
Error type Application
Filtered No
Finding The online calculated CRC16 of FLASH (program memory) is not matching with one calculated and stamped in image by CRC checksum tool while building the source files.
Problem Program Memory of PVED might be corrupted
Likely root cause Electrical disturbance or fault in components
Counteraction Cycle power
--- By multiple reoccurrences replace module.
Deactivation Cycle power

Error codes

Index 18 • Reserved

Obj. Dict. Index 0x2011
CANopen Name ERR_RESERVED_2
Error code ID 0x5001
Severity Reserved
Error register 0x81
Error type Reserved
Filtered No
Finding Reserved
Problem Reserved
Likely root cause Reserved
Counteraction Reserved
Deactivation Reserved

Index 19 • EEPROM write fault

Obj. Dict. Index 0x2012
CANopen Name EEPROM verified write to cell
Error code ID 0x5532
Severity Critical
Error register 0x81
Error type Application
Filtered No
Finding Verification of a EEPROM write was not recognized
Problem EEPROM might not have the right content and therefore PVED might not act as expected
Likely root cause Electrical disturbance or fault in components
Counteraction A: If related to EDS change redo change.
B: Reset Application.
--- By multiple reoccurrence replace module
Deactivation Reset Application

Index 20 • EEPROM content fault

Obj. Dict. Index 0x2013
CANopen Name EEPROM CRC16 failure
Error code ID 0x5533
Severity Severe
Error register 0x81
Error type Application
Filtered No
Finding EEPROM CRC value is not recognized equal to expected value. This fault only occurs at boot up.

Error codes

Problem EEPROM might not have the right content or μC have made a fault and therefore PVED might not act as expected

Likely root cause Electrical disturbance or fault in components

Counteraction A: Reboot module.

--- By multiple reoccurrence replace module

Deactivation Cycle power

Index 21 • EEPROM mirror fault

Obj. Dict. Index 0x2014

CANopen Name EEPROM fall back to old data

Error code ID 0x5534

Severity Critical

Error register 0x81

Error type Application

Filtered No

Finding EEPROM value for main and mirror section is not identical, but one has right CRC value

Problem EEPROM did not have identical copies and therefore a CRC valid version has replaced the incorrect. Therefore old values can have replaced newer.

Likely root cause Power fall out during EEPROM write process

Counteraction A: If related to EDS change verify content.

B: Reset Application.

--- By multiple reoccurrence replace module

Deactivation Reset application

Index 22 • Dead band parameter out of range

Obj. Dict. Index 0x2015

CANopen Name Parameter error dead band compensation

Error code ID 0x6321

Severity Critical

Error register 0x81

Error type Application

Filtered No

Finding Either dead-band on positive side is out of [0, 1000] or dead-band on negative side is out of [-1000, 0]

Problem A safety setting prohibits operations

Likely root cause Wrong setup

Counteraction Define dead band within range

Deactivation Reset application

Index 23 • Reserved

Obj. Dict. Index 0x2016

Error codes

CANopen Name ERR_RESERVED_3
Error code ID 0x8110
Severity Reserved
Error register 0x11
Error type Reserved
Filtered No
Finding Reserved
Problem Reserved
Likely root cause Reserved
Counteraction Reserved
Deactivation Reserved

Index 24 • CAN error frame warning

Obj. Dict. Index 0x2017
CANopen Name CAN in error passive mode
Error code ID 0x8120
Severity Warning
Error register 0x11
Error type Communication
Filtered No
Finding The CAN transceiver has passed error count 127, the warning level of error count and CAN chip is going to be in Passive mode
Problem PVED might go in error passive mode.
Likely root cause A: Illegal communication on bus.
B: Wiring fault.
C: Electrical disturbance or fault in components
Counteraction Evaluate communication and components. If module stops sending reset communication.
Deactivation By communication stop reset communication (Application)

Index 25 • Signal from master missing

Obj. Dict. Index 0x2018
CANopen Name Lifeguard heart beat fault, No heartbeat msg monitoring for master and hence Fault code is not used
Error code ID 0x8130
Severity Warning
Error register 0x11
Error type 0
Filtered 0
Finding Fault not raised
Problem No signal from master
Likely root cause Communication interrupted

Error codes

Counteraction A: Verify master signal

B: Verify communication line

--- By multiple reoccurrences and no external fault found replace module.

Deactivation 0

Index 26 • Recovered from Bus off

Obj. Dict. Index 0x2019

CANopen Name Recovered from Bus off

Error code ID 0x8140

Severity Critical

Error register 0x11

Error type Communication

Filtered No

Finding Module has been in CAN passive mode but is no longer.

Problem CAN communication from module has been interrupted but PVED can now start to transmit again

Likely root cause Noise on CAN line

Counteraction No counteraction. This is for information only. Investigate for noise sources

Deactivation Not available

Index 27 • Command signal error

Obj. Dict. Index 0x201A

CANopen Name PDO not processed due to length err

Error code ID 0x8210

Severity Severe

Error register 0x11

Error type Communication

Filtered No

Finding A PDO did not apply to standard, PDO received is not having length as expected.

Problem Command is ignored

Likely root cause Controller sends undefined message

Counteraction Verify control signal formats

Deactivation Cycle power

Index 28 • Reserved

Obj. Dict. Index 0x201B

CANopen Name ERR_RESERVED_5

Error code ID 0x8220

Severity Reserved

Error register 0x11

Error codes

Error type Reserved
Filtered No
Finding Reserved
Problem Reserved
Likely root cause Reserved
Counteraction Reserved
Deactivation Reserved

Index 29 • Reserved

Obj. Dict. Index 0x201C
CANopen Name ERR_RESERVED_6
Error code ID 0xFFFF
Severity Reserved
Error register 0x00
Error type Reserved
Filtered No
Finding Reserved
Problem Reserved
Likely root cause Reserved
Counteraction Reserved
Deactivation Reserved

Index 30 • Spool not at set point

Obj. Dict. Index 0x201D
CANopen Name CL Monitoring: critical dynamics
Error code ID 0x8305
Severity Critical
Error register 0x81
Error type Application
Filtered Yes
Finding The LVDT shows spool further out than set point. More than 0,84 mm, for more than 500 ms. This fault only occurs in combination with flow commands.
Problem Flow is not as expected. Spool position is as reported in feedback.
Likely root cause A: PVM has been pushed.
B: Oil viscosity is too high – spool stroke is not reduced fast enough.
C: Contamination preventing pilot system to operate as demanded.
Counteraction A: Verify for free movement of spool.
B: Wait until viscosity is within specification.
--- By multiple reoccurrences replace module.
Deactivation Reset application

Error codes

Index 31 • Spool out of neutral

Obj. Dict. Index 0x201E

CANopen Name CL Monitoring: unintended spool movement

Error code ID 0x8306

Severity Critical

Error register 0x81

Error type Application

Filtered Yes

Finding The LVDT feedback has shown spool further out of neutral than 0.5 mm for more than Self TWM Timeout. This fault occurs only in combination with blocked command.

Problem Flow might occur undemanded.

Likely root cause A: PVM has been pushed.

B: Contamination preventing pilot system to operate as demanded.

Counteraction A: Verify for free movement of spool.

--- By multiple reoccurrences replace module.

Deactivation Reset application

Index 32 • Spool out of neutral at boot up

Obj. Dict. Index 0x201F

CANopen Name CL Monitoring: main spool not in neutral at boot up

Error code ID 0x8307

Severity Critical

Error register 0x81

Error type Application

Filtered No

Finding The LVDT feedback has shown spool further out than 0.7 mm at boot up

Problem Spool position might not be trusted

Likely root cause A: PVM has been pushed.

B: Contamination preventing pilot system to operate as demanded.

Counteraction Verify for free movement of spool.

--- By multiple reoccurrences replace module.

Deactivation Reset application

Index 33 • Electronics too warm

Obj. Dict. Index 0x2020

CANopen Name Inst temp electronic components too high

Error code ID 0x4224

Severity Critical

Error register 0x9

Error type Application

Filtered No

Error codes

Finding The reading of the on board temperature sensor shows instant temperature is more than 100 °C for more than 80 ms.

Problem Electronic components might get unstable

Likely root cause A: Overheating,

B: Sensor fault

Counteraction A: Cool down system.

B: Verify likelihood for temperature measurement.

--- By multiple reoccurrences replace module.

Deactivation Reset application

Index 34 • CAN spool position from neighbor missing

Obj. Dict. Index 0x2021

CANopen Name Monitor neighbor time out actual value

Error code ID 0x8001

Severity Warning

Error register 0x91

Error type Communication

Filtered No

Finding Module has not received spool position from neighbor within time guarding, default value is 220ms

Problem Neighbor supervision has fault

Likely root cause A: Wiring fault.

B: Neighbor not sending.

C: Module not receiving

D: Neighbor Node-ID configuration is not proper

Counteraction A: Check wiring.

B: Reset communication or Application.

C: Check neighbor Node-ID configured is correct and mapped to physical valve in group

--- By multiple reoccurrences replace module.

Deactivation Reset communication (application) for both modules

Index 35 • Neighbor CAN spool position fault

Obj. Dict. Index 0x2022

CANopen Name Monitor neighbor data integrity

Error code ID 0x8002

Severity Critical

Error register 0x91

Error type Communication

Filtered No

Finding CANbus spool position reporting from neighbor has a fault. The position and the inverted value do not mach.

Problem Communication can not be trusted.

Error codes

Likely root cause A: Neighbor is sending signal with fault.

B: Module CAN interpretation has faults

Counteraction A: Reset Application.

--- By multiple reoccurrences replace module.

Switch positions to identify module with fault.

Deactivation Reset applications

Index 36 • No set point

Obj. Dict. Index 0x2023

CANopen Name Set point time guarding

Error code ID 0x8003

Severity Warning

Error register 0x91

Error type Communication

Filtered No

Finding Module has not recognized set point from master within time guarding, default value set is 220ms

Problem Missing command signal

Likely root cause A: Wiring fault.

B: Master not sending.

C: Module not receiving

Counteraction A: Check for master status.

B: Check wiring.

C: Reset communication.

D: Reboot system

--- By multiple reoccurrences replace module or wiring.

Deactivation Automatically, once again start receiving set point msg within timeout period

Index 37 • CAN stack error

Obj. Dict. Index 0x2024

CANopen Name CANopen stack error

Error code ID 0x8201

Severity Severe

Error register 0x11

Error type Communication

Filtered No

Finding Software error in the CANopen protocol stack

Problem Communication can not be trusted.

Likely root cause Electrical disturbance or fault in components

Counteraction Cycle power.

--- By multiple reoccurrence replace module.

Deactivation Cycle power

Error codes

Index 38 • DSM initialization failed

Obj. Dict. Index 0x2025
CANopen Name Device specific: DSM error
Error code ID 0xFF01
Severity Severe
Error register 0x11
Error type Communication
Filtered No
Finding The internal Device state machine of device in not initialized properly
Problem Control of PVED not possible
Likely root cause Electrical disturbance or fault in components
Counteraction A: Reboot module.
--- By multiple reoccurrences replace module
Deactivation Not available.

Index 39 • A/D converting fault

Obj. Dict. Index 0x2026
CANopen Name A/D Conversion error
Error code ID 0x5234
Severity Critical
Error register 0x81
Error type Application
Filtered No
Finding PVED-CX4 micro-controller has raised an internal AD conversion error flag
Problem PVED-CX4 can not evaluate analogue input e.g. Spool position
Likely root cause Electrical disturbance or fault in components
Counteraction A: Reset Application.
--- By multiple reoccurrences replace module.
Deactivation Reset application

Index 40 • ASSIST. State fault

Obj. Dict. Index 0x2027
CANopen Name ASSIST: operational error
Error code ID 0xFF10
Severity Severe
Error register 0x81
Error type Application
Filtered No
Finding ASSIST Operational state does not match the expected state. Internal ASSIST state machine.
Problem ASSIST can not be performed
Likely root cause Electrical disturbance or fault in components

Error codes

Counteraction Cycle power.
--- By multiple reoccurrences replace module.
Deactivation Cycle power

Index 41 • ASSIST. Timing fault

Obj. Dict. Index 0x2028
CANopen Name ASSIST: overall time guarding
Error code ID 0xFF11
Severity Critical
Error register 0x81
Error type Application
Filtered No
Finding Module did not receive the final expected ASSIST successful message
Problem ASSIST can not be performed
Likely root cause Electrical disturbance or fault in components
Counteraction Reset Application.
--- By multiple reoccurrences replace module.
Deactivation Reset applications

Index 42 • Neighbor. Spool out of neutral at boot up.

Obj. Dict. Index 0x2029
CANopen Name CL Monitoring of Neighbor: main spool not in neutral at boot up
Error code ID 0x8308
Severity Critical
Error register 0x81
Error type Application
Filtered Yes
Finding Neighbor module spool is not seen in neutral at boot up.
Problem Neighbor spool might not follow command. Possible risk for undemanded flow.
Likely root cause If fault "spool out of neutral at boot up" is not raised by neighbor.
A: Wiring fault.
B: Calculation fault in neighbor.
C: Calculation fault in module.
Counteraction A: Check wiring.
B: Reset Application.
– By multiple reoccurrences replace module.
Deactivation Reset application

Index 43 • ASSIST. Neighbor reporting fault

Obj. Dict. Index 0x202A
CANopen Name ASSIST: diff. between analog and CAN-BUS spoolpos

Error codes

Error code ID 0xFF12

Severity Critical

Error register 0x81

Error type Application

Filtered No

Finding Neighbor analogue and digital spool position reporting did not match in ASSIST mode.

Problem ASSIST can not be performed

Likely root cause A: Wiring fault.

B: Electrical disturbance

C: Fault in components

Counteraction A: Check wiring.

B: Reset Application.

--- By multiple reoccurrences replace module.

Deactivation Reset applications

Index 44 • ASSIST. Spool not returned to neutral

Obj. Dict. Index 0x202B

CANopen Name ASSIST: self spool does not return to neutral

Error code ID 0xFF13

Severity Critical

Error register 0x81

Error type Application

Filtered No

Finding Spool did not return to neutral when Vbat2 was cut off

Problem Safety system might not be trusted

Likely root cause A: Mechanical fault blocks spool return.

B: Safety switch can not be interrupted.

Counteraction A: Check for blocked PVM.

B: Reset Application.

--- By multiple reoccurrences replace module

Deactivation Reset applications

Index 45 • ASSIST. Step fault

Obj. Dict. Index 0x202C

CANopen Name ASSIST: step completion message check failed

Error code ID 0xFF14

Severity Critical

Error register 0x81

Error type Application

Filtered No

Finding The step sequence received in CAN message while performing ASSIST is not proper

Error codes

Problem ASSIST can not be performed
Likely root cause Electrical disturbance or fault in components
Counteraction Reset Application.
--- By multiple reoccurrences replace module.
Deactivation Reset applications

Index 46 • ASSIST. Neighbor spool does not steer out

Obj. Dict. Index 0x202D
CANopen Name ASSIST: neighbor spool does not steer out
Error code ID 0xFF15
Severity Critical
Error register 0x81
Error type Application
Filtered No
Finding ASSIST Mode- Spool not found moving by neighbor while module is performing ASSIST
Problem Neighbor might not get proper spool position feedback from monitored module
Likely root cause If spool is moving and neighbor is not able to capture the movement.
A: Wiring problem,
B: Neighbor-Node-ID configuration problem
Counteraction A: Check wiring.
B: Reset Application.
--- By multiple reoccurrences replace module.
Deactivation Not available.

Index 47 • ASSIST. Neighbor spool not returned to neutral

Obj. Dict. Index 0x202E
CANopen Name ASSIST: neighbor spool does not return to neutral
Error code ID 0xFF16
Severity Critical
Error register 0x81
Error type Application
Filtered No
Finding Neighbor spool did not return to neutral when Vbat2 was cut off
Problem Safety system might not be trusted
Likely root cause A: Mechanical fault blocks spool return.
B: Safety switch can not be interrupted.
C: Neighbor monitoring doesn't work
Counteraction A: Check for blocked PVM.
B: Reset Application.
--- By multiple reoccurrences replace module
Deactivation Reset applications

Error codes

Index 48 • ASSIST: A port gives to high flow

Obj. Dict. Index 0x202F

CANopen Name ASSIST: too much spool movement in A-port

Error code ID 0xFF17

Severity Critical

Error register 0x81

Error type Application

Filtered No

Finding In ASSIST mode spool moved more than required 214IR (± 7) ~ 1.5mm in A port while testing in this port for spool movement.

Problem Flow might occur uncommanded.

Likely root cause Electrical disturbance or fault in components

Counteraction Reset Application or cycle power.

--- By multiple reoccurrences replace module

Deactivation Reset applications

Index 49 • ASSIST: B port gives to high flow

Obj. Dict. Index 0x2030

CANopen Name ASSIST: too much spool movement in B-port

Error code ID 0xFF18

Severity Critical

Error register 0x81

Error type Application

Filtered No

Finding In ASSIST mode spool moved more than required 214IR (± 7) ~ 1.5mm in B port while testing in this port for spool movement.

Problem Flow might occur uncommanded.

Likely root cause Electrical disturbance or fault in components

Counteraction Reset Application or cycle power.

--- By multiple reoccurrences replace module

Deactivation Reset applications

Index 50 • ASSIST: A port gives to low flow

Obj. Dict. Index 0x2031

CANopen Name ASSIST: too less spool movement in A-port

Error code ID 0xFF19

Severity Critical

Error register 0x81

Error type Application

Filtered No

Finding In ASSIST mode spool moved less than required 711R (± 7) ~ 0.5mm in A port while testing in this port for spool movement

Error codes

Problem Flow is not as expected.

Likely root cause A: Blocked spool

B: Contamination preventing pilot system to operate as demanded.

Counteraction Verify for free movement of spool.

Reset Application or cycle power.

--- By multiple reoccurrences replace module

Deactivation Reset applications

Index 51 • ASSIST: B port gives to less flow

Obj. Dict. Index 0x2032

CANopen Name ASSIST: too less spool movement in B port

Error code ID 0xFF1A

Severity Critical

Error register 0x81

Error type Application

Filtered No

Finding In ASSIST mode spool moved less than required 71IR (± 7) ~ 0.5mm in B port while testing in this port for spool movement

Problem Flow is not as expected.

Likely root cause A: Blocked spool

B: Contamination preventing pilot system to operate as demanded.

Counteraction Verify for free movement of spool.

Reset Application or cycle power.

--- By multiple reoccurrences replace module

Deactivation Reset applications

Index 52 • Neighbor. Spool out of neutral

Obj. Dict. Index 0x2033

CANopen Name CL Monitoring of Neighbor: unintended spool movement

Error code ID 0x8309

Severity Critical

Error register 0x81

Error type Application

Filtered Yes

Finding Neighbor module spool is not seen to stay in neutral as commanded.

Problem Neighbor spool might not follow command. Possible risk for undemanded flow.

Likely root cause If fault "spool out of neutral" is not raised by neighbor.

A: Different time out due to temperature difference.

B: Extreme variation in set points.

C: Verify correct mounting of cable

D: Calculation fault in neighbor.

E: Calculation fault in module.

Error codes

Counteraction A: Check wiring.
B: Reset Application.
--- By multiple reoccurrences replace module.
Deactivation Reset application

Index 53 • Neighbor. Spool not at set point

Obj. Dict. Index 0x2034
CANopen Name CL Monitoring of Neighbor: critical dynamics
Error code ID 0x830A
Severity Critical
Error register 0x81
Error type Application
Filtered Yes
Finding Neighbor module spool is not seen to follow set point appropriate.
Problem Neighbor spool might not follow command
Likely root cause If fault "spool not at set point" is not raised by neighbor.
A: Different time out due to temperature difference.
B: Extreme variation in set points.
C: Wiring fault.
D: Calculation fault in neighbor.
E: Calculation fault in module.
Counteraction A: Evaluate valve operations.
B: Check wiring.
C: Reset Application.
--- By multiple reoccurrences replace module.
Deactivation Reset application

Index 54 • Neighbor. Spool position reporting fault

Obj. Dict. Index 0x2035
CANopen Name CL Monitoring of Neighbor: diff. between analog and CAN-BUS spoolpos.
Error code ID 0x830B
Severity Critical
Error register 0x81
Error type Application
Filtered Yes
Finding Neighbor module spool position report on CANbus and analogue is not matching
Problem Neighbor spool position report cannot be trusted
Likely root cause A: Extreme variation in set points.
B: Wiring fault.
C: Calculation fault in neighbor.

Error codes

D: Calculation fault in module.
Counteraction A: Evaluate valve operations.
B: Check wiring.
C: Reset Application.
--- By multiple reoccurrences replace module.
Deactivation Reset application

Index 55 • Reference voltage fault

Obj. Dict. Index 0x2036
CANopen Name Drift of ADC ref. voltage or SMPS
Error code ID 0x3111
Severity Critical
Error register 0x5
Error type Application
Filtered Yes
Finding The reference voltage to Analog to Digital converter on controller from SMPS of module is not found within limit [2.25, 2.75]V
Problem LVDT, Temperature Sensor, External Battery Voltage reading might not be trusted
Likely root cause Electrical disturbance or fault in components
Counteraction A: Reset Application.
--- By multiple reoccurrences replace module.
Deactivation Reset applications

Index 56 • Node ID fault

Obj. Dict. Index 0x2037
CANopen Name Configuration of node id and group id
Error code ID 0x8004
Severity Severe
Error register 0x81
Error type Application
Filtered No
Finding The PVED detected that neighbor node-id configured is not from same group to which it belongs
Problem PVED can not operate.
Likely root cause A: Node and neighbor were not in same Id group.
B: Node and neighbor have same ID.
C: Node and/or neighbor ID is invalid.
Counteraction Evaluate numbering. Set valid numbers.
Deactivation Set valid numbers

Index 57 • EEPROM address fault

Obj. Dict. Index 0x2038

Error codes

CANopen Name Invalid EEPROM address

Error code ID 0x5535

Severity Severe

Error register 0x81

Error type Application

Filtered No

Finding During read or write to EEPROM an address fault was seen. Application is trying to write in Boot sector of EEPROM below 500 address.

Problem System might not be trusted

Likely root cause Electrical disturbance or fault in components

Counteraction Cycle power.

--- By multiple reoccurrences replace module.

Deactivation Cycle power

Index 58 • Error code buffer

Obj. Dict. Index 0x2039

CANopen Name Buffer overflow

Error code ID 0x6208

Severity Severe

Error register 0x81

Error type Application

Filtered No

Finding Error code s/w buffer overflow.

Problem PVED can not operate properly.

Likely root cause A: High occurrence of faults.

B: Electrical disturbance or fault in components

Counteraction Cycle power.

--- By multiple reoccurrences replace module.

Deactivation Cycle power

Ordering information

Settings Agreement

When PVG32 with PVED-CX4 are ordered a Settings Agreement must be forwarded as well as assembly specification. Agreements can be made as a:

- Specific agreement for a single specification
- General agreement for PVG

The Hydraulic test is a mandatory part of the PVG32 with PVED-CX4.

Parameter Agreement Template

Customer OEM Parameter list - OEM Data for PVED-CX4

Agreement between

Customer Name:

Business unit PVG, Danfoss:

Filled in by:

Customer representative:

SD sales representative:

Date:

Factory settings for spare part PVED-CX4

Configurable parameters in EDS, same as fig. 31

Name	Default	Range	Index, sub
Node ID	0xFF	See fig 26	
EMCY inhibit time ¹⁾	0xC8	0x64 - 0xC8, multiple of DEC 100 micro seconds	0x1015, -
Producer heart beat time ²⁾	0x0	0 if it is not used.	0x1017, -
Set point time guarding	0xDC	0x0 - 0xFA	0x1400, 5
Neighbor spool position time guarding	0xDC	0x0 - 0xFA	0x1402, 5
vpc_neighbor_monitoring_additional_tolerance_in_IR ³⁾	200	0 - 1000	0x2101, -
Self TWM Timeout ⁴⁾	0xC8	0x0 - 0x1F4	0x2102, 1
Neighbor TWM Timeout	0xC8	0x0 - 0x1F4	0x2102, 2
Sync Message Event Timer ⁵⁾	0xDC	0x0 - 0xFA	0x2103, -
Device description	CANopen_R1.33	Free choice of 32 ASCII	0x6053, -
Dead-band compensation A	186	100 - 1000	0x6343, 1
Dead-band compensation B	-186	(-100) - (-1000)	0x6344, 1

¹⁾ Minimum time between two EMCY published on CAN.

²⁾ See "Heartbeat Messages".

³⁾ Distance between CAN position and analog position.

⁴⁾ Time from blocked set point to monitoring with increased conditions

⁵⁾ Time from last SYNC to forced HOLD state.

Ordering information

PVED-CX4 setting agreement for PVG

PVED-CX4 setting agreement for PVG

	PVED 1	PVED 2	PVED 3	PVED 4	PVED 5	PVED 6	PVED 7	PVED 8
Node ID	0x10	0x11	0x12	0x13	0x14	0x15	0x16	0x17
Neighbor Node ID	0x17	0x10	0x11	0x12	0x13	0x14	0x15	0x16
EMCY inhibit time	0xC8	0xC8	0xC8	0xC8	0xC8	0xC8	0xC8	0xC8
Producer heart beat time	0x0	0x0	0x0	0x0	0x0	0x0	0x0	0x0
Device description	CANopen _R1.33	CANopen _R1.33	CANopen _R1.33	CANopen _R1.33	CANopen _R1.33	CANopen _R1.33	CANopen _R1.33	CANopen _R1.33
Dead-band compensation A	186	186	186	186	186	186	186	186
Dead-band compensation B	-186	-186	-186	-186	-186	-186	-186	-186

PVED 1 is the PVED the closest to PVP. All changed cells must have light gray shading and bold font. The list can be extended to twelve modules - relation in control section must be applied.

Control section overview

Ctrl sec	Node Id and neighbor node Id in group							
1	0x10	0x11	0x12	0x13	0x14	0x15	0x16	0x17
2	0x18	0x19	0x1A	0x1B	0x1C	0x1D	0x1E	0x1F
3	0x20	0x21	0x22	0x23	0x24	0x25	0x26	0x27
4	0x28	0x29	0x2A	0x2B	0x2C	0x2D	0x2E	0x2F
5	0x30	0x31	0x32	0x33	0x34	0x35	0x36	0x37
6	0x38	0x39	0x3A	0x3B	0x3C	0x3D	0x3E	0x3F

Cable connector relation

Relation between Node Id and Neighbor Node Id in cable kit					
Connector	J1	J2	J3	...	JN
Neighbor connector	JN	J1	J2	...	JN-1
Example					
Node Id	20	21	22	...	26
Neighbor node Id	26	20	21	...	25

List of correlations between Node Id and function.

- | | |
|-------------------------|----------|
| - 0x10 = e.g. Swing | - 0x18 = |
| - 0x11 = e.g. Extension | - 0x19 = |
| - 0x12 = e.g. ... | - 0x1A = |
| - 0x13 = | - 0x1B = |
| - 0x14 = | - 0x1C = |
| - 0x15 = | - 0x1D = |
| - 0x16 = | - 0x1E = |
| - 0x17 = | - 0x1F = |

Ordering information

PVED-CX4 code numbers

PVED-CX4 code numbers

Name	Description	Code numbers
PVED-CX4	PVED-CX4 for CANopen	11266372
Cable Kit	CX4, AMP, 2 sections, 4 m, w/o termination	11293337
	CX4, AMP, 3 sections, 4 m, w/o termination	11293338
	CX4, AMP, 4 sections, 4 m, w/o termination	11293339
	CX4, AMP, 5 sections, 4 m, w/o termination	11293330
	CX4, AMP, 6 sections, 4 m, w/o termination	11293300
	CX4, AMP, 7 sections, 4 m, w/o termination	11293291
	CX4, AMP, 8 sections, 4 m, w/o termination	11293342
	CX4, AMP, 3 sections, 1.2 m, w/120 Ohm termination in J3	11293331
	CX4, AMP, 5 sections, 1.2 m, w/120 Ohm termination in J5	11293301
	CX4, AMP, 6 sections, 1.2 m, w/120 Ohm termination in J6	11293352
	CX4, AMP, 7 sections, 1.2 m, w/120 Ohm termination in J7	11293343
	CX4, AMP, 8 sections, 1.2 m, w/120 Ohm termination in J8	11293353
	Seal kit	O-rings for PVED-CX4

An example of the relevant EDS file is available through your Danfoss sales representative.

Ordering information

PVED-CX4 spare part code numbers

PVED-CX4 spare part code numbers

Name	Description	Code numbers
Spare part kit	PVED-CX4 Series 7 with 17 mm Extension plate kit ¹	11293949
	PVED-CX4 Series 7 with 39.5 mm Extension plate kit	11293935

¹ The 17 mm spare part kit is intended for use when exchanging a PVED-CX series 4 in-field when the cable kit has been exchanged to a CX4 cable kit.

The 39.5 mm spare part kit is intended for use when exchanging a PVED-CX Series 4 in-field, using the old CX Series 4 cable kit (without exchanging the cable kit for a CX4 cable kit).

Products we offer:

- Cartridge valves
- DCV directional control valves
- Electric converters
- Electric machines
- Electric motors
- Gear motors
- Gear pumps
- Hydraulic integrated circuits (HICs)
- Hydrostatic motors
- Hydrostatic pumps
- Orbital motors
- PLUS+1® controllers
- PLUS+1® displays
- PLUS+1® joysticks and pedals
- PLUS+1® operator interfaces
- PLUS+1® sensors
- PLUS+1® software
- PLUS+1® software services, support and training
- Position controls and sensors
- PVG proportional valves
- Steering components and systems
- Telematics

Danfoss Power Solutions is a global manufacturer and supplier of high-quality hydraulic and electric components. We specialize in providing state-of-the-art technology and solutions that excel in the harsh operating conditions of the mobile off-highway market as well as the marine sector. Building on our extensive applications expertise, we work closely with you to ensure exceptional performance for a broad range of applications. We help you and other customers around the world speed up system development, reduce costs and bring vehicles and vessels to market faster.

Danfoss Power Solutions – your strongest partner in mobile hydraulics and mobile electrification.

Go to www.danfoss.com for further product information.

We offer you expert worldwide support for ensuring the best possible solutions for outstanding performance. And with an extensive network of Global Service Partners, we also provide you with comprehensive global service for all of our components.

Local address:

Hydro-Gear

www.hydro-gear.com

Daikin-Sauer-Danfoss

www.daikin-sauer-danfoss.com

**Danfoss
Power Solutions (US) Company**
2800 East 13th Street
Ames, IA 50010, USA
Phone: +1 515 239 6000

**Danfoss
Power Solutions GmbH & Co. OHG**
Krokamp 35
D-24539 Neumünster, Germany
Phone: +49 4321 871 0

**Danfoss
Power Solutions ApS**
Nordborgvej 81
DK-6430 Nordborg, Denmark
Phone: +45 7488 2222

**Danfoss
Power Solutions Trading
(Shanghai) Co., Ltd.**
Building #22, No. 1000 Jin Hai Rd
Jin Qiao, Pudong New District
Shanghai, China 201206
Phone: +86 21 2080 6201

Danfoss can accept no responsibility for possible errors in catalogues, brochures and other printed material. Danfoss reserves the right to alter its products without notice. This also applies to products already on order provided that such alterations can be made without subsequent changes being necessary in specifications already agreed. All trademarks in this material are property of the respective companies. Danfoss and the Danfoss logotype are trademarks of Danfoss A/S. All rights reserved.