

047C423

047C0423

#### Montering - Mounting - Montage

mm (inch)

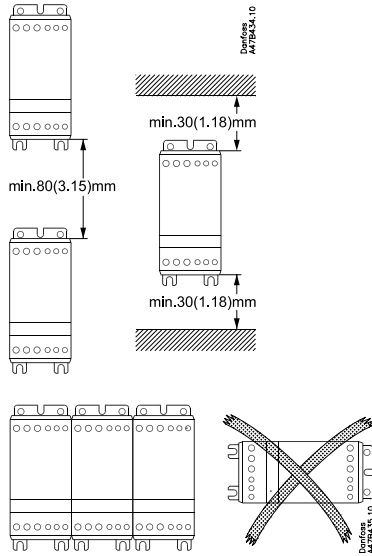

DK Hvis enhed er monteret vandret reducer strøm med 50%  
 UK If unit is mounted horizontally derate current by 50%  
 D Falls Einheit horizontal montiert wird, reduziert sich der Strom um 50%.

#### Mål - Dimensions - Abmessungen

mm (inch)

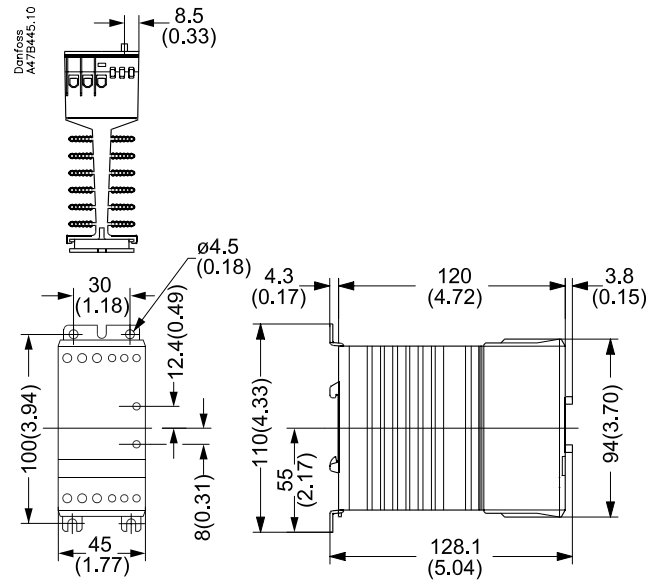

DK Køleplade skal holdes ren. Luftstrøm må ikke blokeres  
 UK Keep heat sink clean. Airflow should not be blocked  
 D Kühlfächen freihalten. Luftstrom muß ungehindert fließen

#### Forbindelse - Wiring - Verdrahtung

75°C Cable/ Wire	mm <sup>2</sup> (AWG)	mm <sup>2</sup> (AWG)
**	0.75 - 4 (18 - 12)	0.5 - 1.5 (20 - 16)
	2 x 1 (2 x 18)	2 x 0.5 - 0.75 (2 x 20 - 18)
**	0.75 - 6 (18 - 10)	0.5 - 1.5 (20 - 16)
	2 x 0.75 - 2.5 (2 x 18 - 14)	2 x 0.5 - 1.5 (2 x 20 - 16)
**	0.75 - 6 (18 - 10)	0.5 - 1.5 (20 - 16)
	2 x 0.75 - 1.5 (2 x 18 - 16)	2 x 0.5 - 1.5 (2 x 20 - 16)
	Pozidrive 1 0.5 Nm max. 4.4 lb-in max.	N.A.
	4 mm 0.5 Nm max. 4.4 lb-in max.	3 mm 0.5 Nm max. 4.4 lb-in max.

- **Vigtigt:** (Overhold max. skruedrejningsmomenter)
- **Important:** (Observe the maximum screw torque limits)
- **Wichtig:** (Max. Drehmoment beachten)
- \* Use copper conductor only
- \*\* UL tested

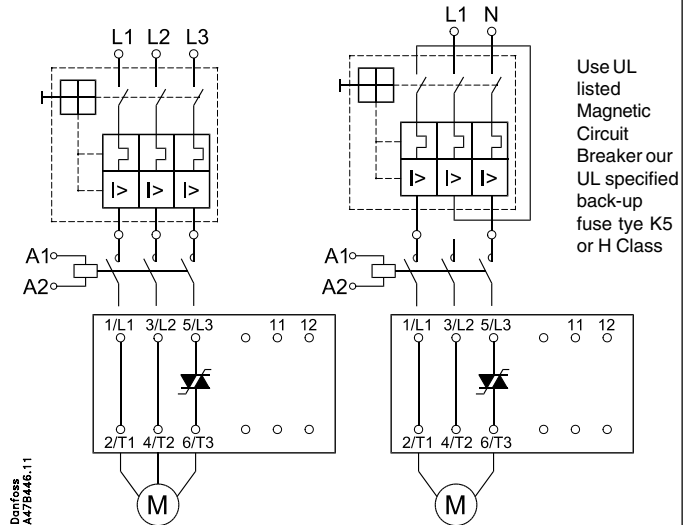

NB:  
 DK Hvis beskyttet med sikringer, se specifikationer i datablad  
 UK If protection with fuses, see recommendations in data sheet  
 D Falls Sicherungen verwendet werden, Empfehlungen im Datenblatt beachten

P.S. This product has been designed for class A equipment. Use of the product in domestic environment may cause radio interference, in which case the user may be required to employ additional mitigation methods.



UL LISTED

UL: Use thermal overload protection as required by the National Electric Code  
 UL: When protected by a non-time delay K5 or H Class fuse, rated 266% of motor FLA, this device is rated for use on a circuit capable of delivering not more than 5,000 rms. symmetrical amperes, 600 V maximum. Maximum surrounding temperature 40°C

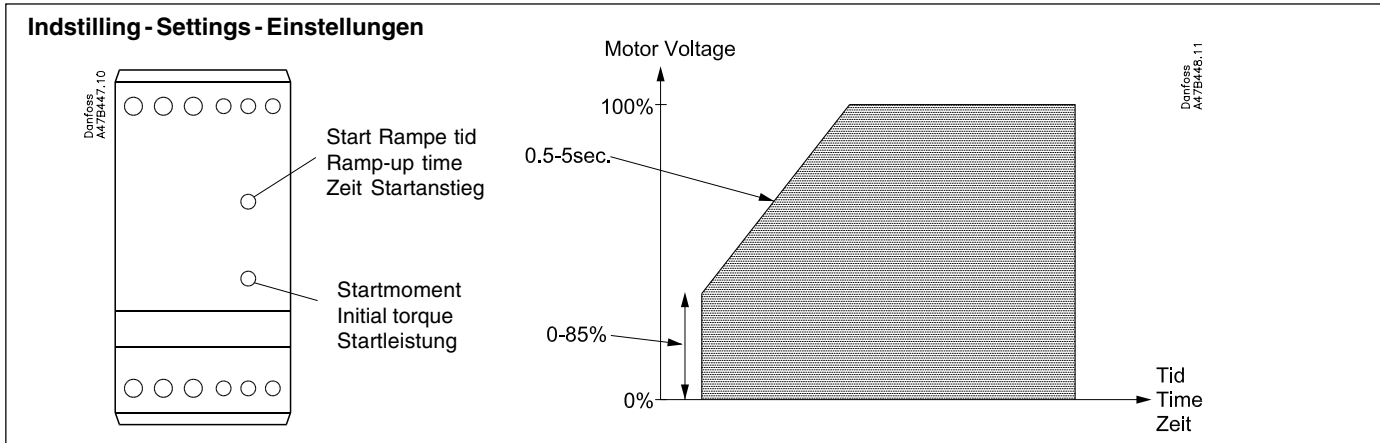

### Bemærkninger - Remarks - Bemerkungen

	Dansk	English	Deutsch
<b>NB!</b>	<ul style="list-style-type: none"> <li>Anvend 2 mm x 0.5 mm skruetrækker.</li> <li>Gentagne starter kan resultere i at motor overbelastningsrelæ aktiveres.</li> </ul>	<ul style="list-style-type: none"> <li>Use 2 mm x 0.5 mm screwdriver.</li> <li>Repeated starts may trip motor protection relay.</li> </ul>	<ul style="list-style-type: none"> <li>Schraubenzieher 2 mm x 0.5 mm verwenden.</li> <li>Mehrfache Starts können das Motorschutzrelais auslösen.</li> </ul>

### Startmoment indstilling - Initial torque setting - Einstellung der Startleistung

	Dansk	English	Deutsch
<p>Ramp up time</p> <p>Initial torque</p>	<ol style="list-style-type: none"> <li>Indstil <b>Ramp-up</b> kontakt til max.</li> <li>Indstil <b>Initial Torque</b> kontakt til min.</li> <li>Påtryk signalspænding i et par sekunder, hvis ikke motorakslen roterer øjeblikkelig efter start juster <b>Initial torque</b> en deling op. Gentag indtil motoraksel roterer øjeblikkelig efter start.</li> </ol>	<ol style="list-style-type: none"> <li>Set <b>Ramp-up</b> switch to max.</li> <li>Set <b>Initial torque</b> switch to min.</li> <li>Apply control signal for a few seconds. If the load does not rotate immediately increase the <b>Initial torque</b> for one step and try again. Repeat until the load starts to rotate immediately on start up.</li> </ol>	<ol style="list-style-type: none"> <li><b>Ramp-up</b> Schalter auf max. stellen</li> <li><b>Initial torque</b> Schalter auf min. stellen</li> <li>Steuersignal einige Sekunden betätigen. Falls der Motor nicht sofort anläuft <b>Initial torque</b> schrittweise erhöhen, bis der Motor anläuft.</li> </ol>

### Start rampe indstilling - Ramp up settings - Einstellung der Startanstiegszeit

	Dansk	English	Deutsch
<p>Ramp up time</p>	<ol style="list-style-type: none"> <li>Indstil <b>Ramp-up</b> tiden til max. og start motor.</li> <li>Gradvis nedsæt <b>Ramp-up</b> tiden indtil motor starter som ønsket.</li> </ol>	<ol style="list-style-type: none"> <li>Set <b>Ramp-up</b> switch to max. and start motor.</li> <li>Decrease the <b>Ramp-up</b> time until desired start is achieved.</li> </ol>	<ol style="list-style-type: none"> <li><b>Ramp-up</b> Schalter auf max. stellen.</li> <li><b>Ramp-up</b> Zeit solange verkürzen bis der Motor wie gewünscht anläuft.</li> </ol>