

Airflex®

Type VC
Rotorseals

Pneumatic Controls
Inching Drives

Electrical Controls

Clutches for Grinding Mills

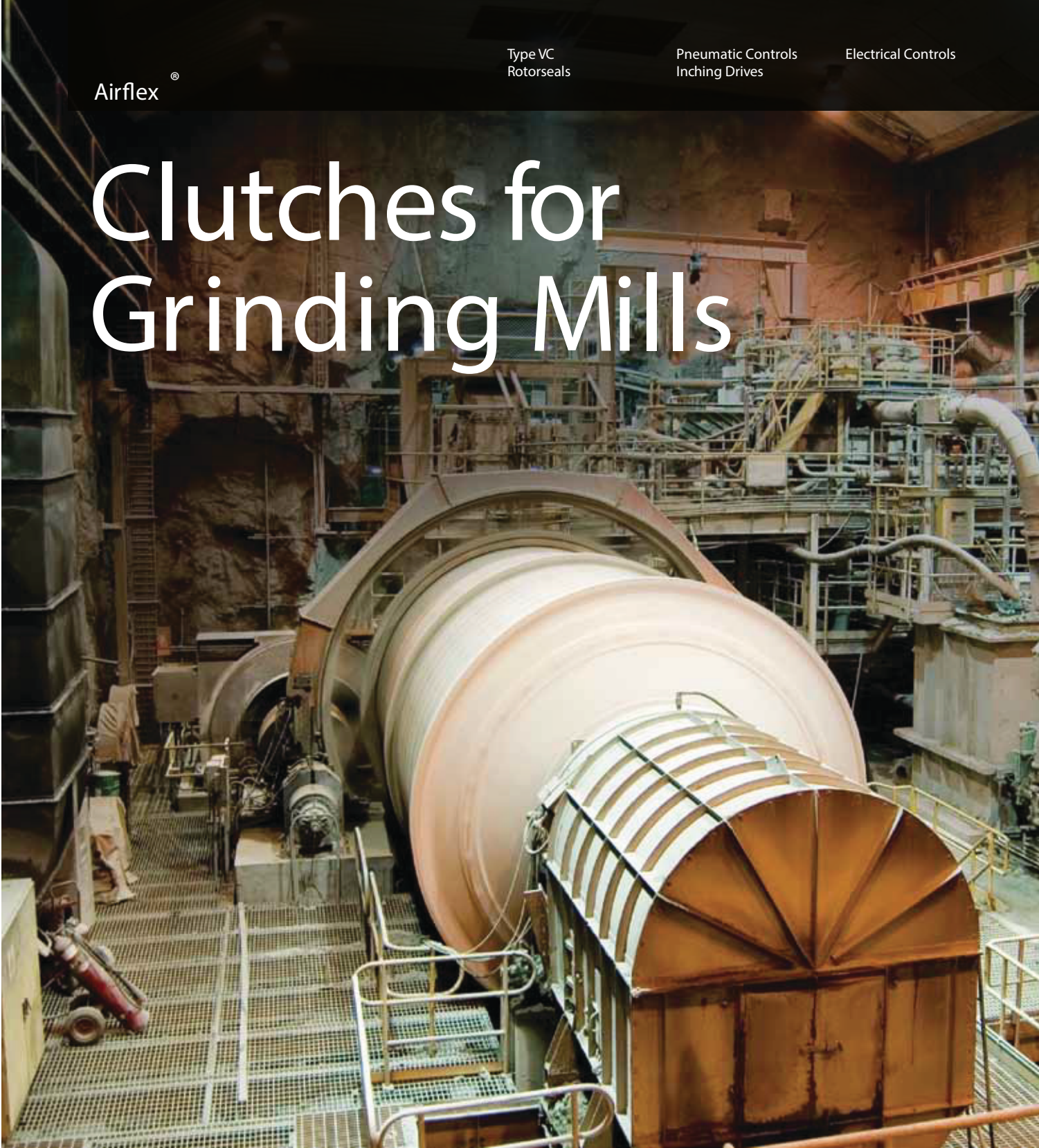

AF435375663990en-000102

VC Clutches for Grinding Mills

Airflex® is the logical choice for new grinding mill designs or for modernizing existing equipment.

Airflex's air-actuated, drum-type clutches are the logical choice for master clutch service on pebble, rod, ball, semi-autogenous and autogenous mills used in the grinding of various materials.

The uncomplicated design and the ability to modulate power transmission insures reliable service and minimum maintenance costs in all mill designs.

When modernizing existing mills or other equipment, very little engineering is required for installing Airflex clutches in place of existing direct drive systems.



Uncomplicated design

Air actuation and the absence of linkages, splines or complex electrical circuitry, needed with other types of clutches, eliminates many mechanical failures and minimizes costly downtime. Air is only used during engagement of an Airflex Clutch. This is because the clutches are designed as closed loop systems.

Neither the driving nor the driven shafts need to be removed to service the clutch. The clutch element and drum can be dropped out between the shafts by unbolting them from the mounting components.

Capacities

Danfoss Airflex offers VC clutches in a wide range of both single and dual elements with torque capacities up to 9,300,000 lb.-ins. (1,050,760 N.m)

Reduced initial equipment cost

Use of Airflex clutches makes it possible to drive grinding mills with synchronous motors, or high speed motor and gearbox designs with the clutch mounted on the output shaft of the gearbox, to avoid the need for the additional costly investment required for high torque equipment.

Where speeds permit, Airflex clutches can also be used for inching or jogging the grinding mill into position for charging, discharging, or relining. Thus costly external jogging equipment is not required.

Mounting of these clutches is uncomplicated. The clutch replaces a solid or shear pin coupling that would have to be used in a high torque drive system.

Total Solution

Airflex provides a total solution for grinding mill applications. This includes:

- VC Clutch
- Rotorseal
- Pneumatic Controls
- Electrical Controls
- Hydraulic Inching Drives

Shock-free engagement

Airflex clutches bring grinding mill loads on line gradually, preventing peak power demands which exceed allowed maximums. The clutches bring high inertia loads up to operating speeds in seconds. Smooth starting protects drive trains from severe shock associated with high torque motors and across-the-line starters.

Long service life

Airflex clutches have extremely high torque capacity, with a full 360-degree, drum-type friction surface. This allows the friction material to wear evenly across its face. Ventilated construction provides rapid heat dissipation during mill start-up.

There is no mechanical linkage to maintain and Airflex clutches require no lubrication. Adjustment is never necessary since the air-filled, rubber-and-cord actuating tube automatically compensates for friction shoe wear.

The drum type design assures that there is no unintentional wear due to dragging. The reason: centrifugal force acting on the clutch shoes results in total disengagement when air pressure is released.

An example of Airflex clutch service life is given by one mill superintendent, who gives his Airflex VC grinding mill clutch major credit for a 4 percent annual production increase.

He eliminated once-a-month

repairs on a 600 hp synchronous motor because the Airflex principle permits modulated power transmission. Peak power demands were lowered and overall power costs were reduced.

No-load starting

Airflex clutches permit grinding mill motors to be started in the "unloaded" condition, keeping current demand within limits agreed upon with local utilities. The result is a substantial saving on power costs. No-load starting also prevents blowing fuses or opening circuit breakers, which would result in unnecessary downtime.

The curves below compare peak power demands of high torque motor-direct drive systems and the Airflex standard torque motor-modulated power transmission systems which replaced them.

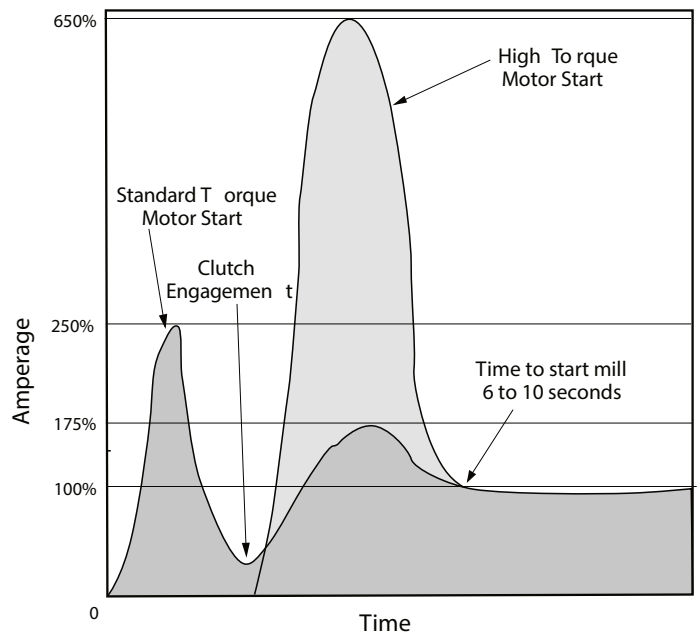

Airflex® VC Clutch Application
 Form VC 506 — Single Narrow Series

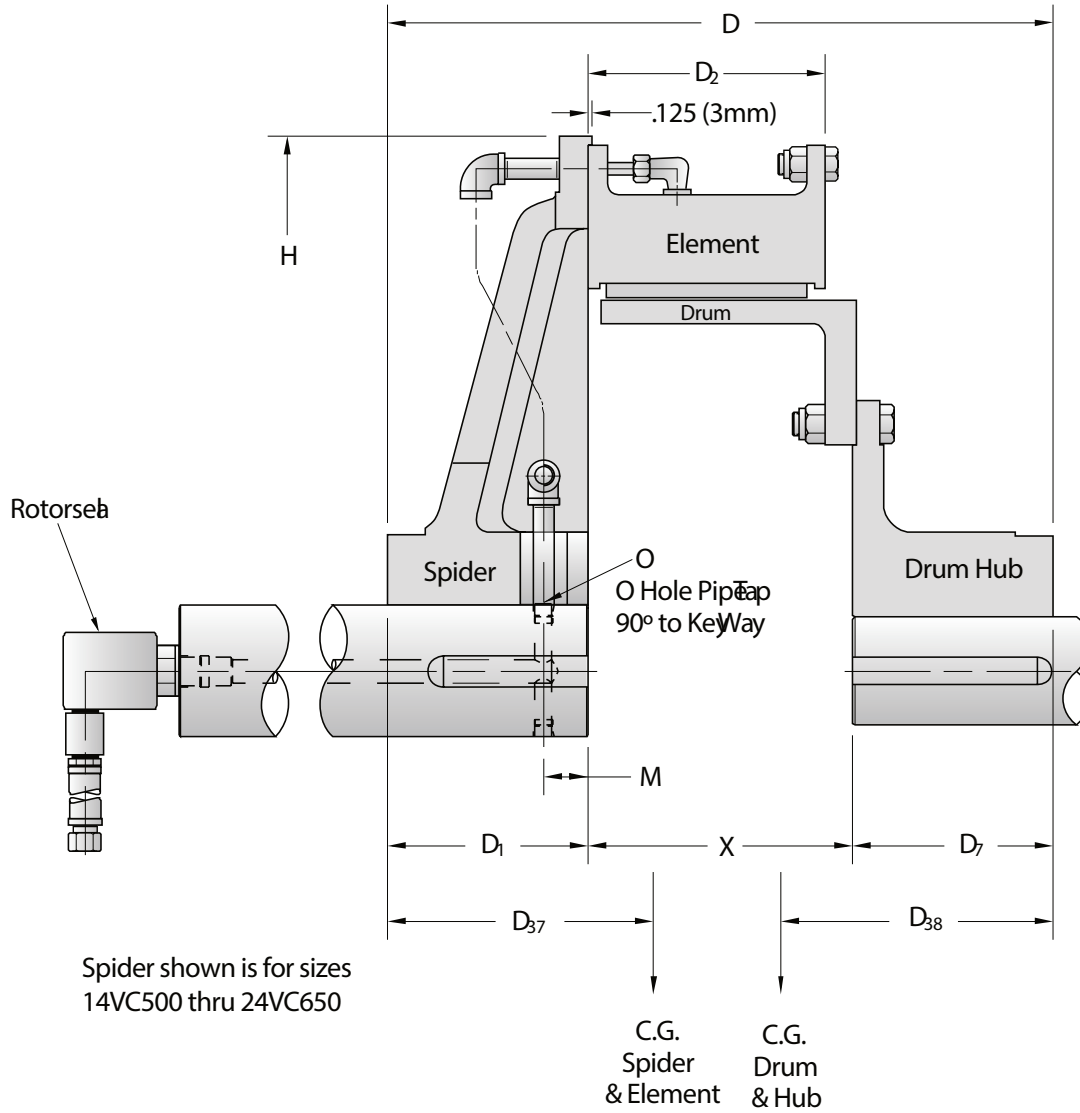

English				Bore Range (inches)			
Size	Basic B/M	Torque Rating (lb-ins) at 75 PSI	Weight (lbs)	Spider Min.	Max.	Hub Min.	Max.
11.5VC50004601		27,000	247	2.500	4.125	2.500	4.125
14VC500 104602		39,200	362	2.750	5.000	2.750	5.000
16VC600 104603		65,000	446	3.250	5.000	3.250	5.000
20VC600 104604		93,000	637	3.750	5.500	3.750	5.500
24VC650 104605		135,000	828	4.250	6.000	4.250	6.000
28VC650 104606		182,000	1265	4.750	8.000	4.750	8.000
33VC650 104607		255,000	1767	5.250	9.500	5.250	9.500
37VC650 104608		320,000	2111	5.500	9.500	5.500	9.500
42VC650 104609		380,000	2738	6.000	10.500	6.000	10.500

SI				Bore Range (millimeters)			
Size	Basic B/M	Torque Rating (N-m) at 5,2 bar	Mass (kg)	Spider Min.	Max.	Hub Min.	Max.
11.5VC50004601		3,050	112	64	105	64	105
14VC500 104602		4,430	164	70	127	70	127
16VC600 104603		7,340	202	83	127	83	127
20VC600 104604		10,505	289	95	140	95	140
24VC650 104605		15,250	375	108	152	108	152
28VC650 104606		20,560	573	121	203	121	203
33VC650 104607		28,810	800	133	241	133	241
37VC650 104608		36,155	956	140	241	140	241
42VC650 104609		42,930	1241	152	267	152	267

English Size	(Dimensions in inches)										Clearance for "Drop Out"	
	D	D ₁	D ₂	D ₇	D ₃₇	D ₃₈	H	M	O	X	Element	Drum
11.5VC50006.09	4.344	6.125	5.000	5.3	5.5	20.000	1	2	6.750	.27	.12	
14VC500 18.06	5.500	6.125	5.750	6.0	5.8	24.000	1.438	1/8-18 NPT	6.812	.25	.19	
16VC600 19.31	5.500	7.375	5.750	6.2	6.5	26.000	1.438	1/8-18 NPT	8.062	.25	.19	
20VC600 20.56	6.000	7.375	6.500	6.0	6.9	30.000	1.438	1/8-18 NPT	8.062	.25	.19	
24VC650 21.56	6.500	7.688	6.500	6.6	7.2	34.625	1.438	1/8-18 NPT	8.562	.36	.19	
28VC650 24.56	8.000	7.688	8.000	6.9	7.9	38.625	5.000	1/2-14 NPT	8.562	.36	.19	
33VC650 26.56	9.000	7.688	9.000	7.5	8.3	45.250	5.000	1/2-14 NPT	8.562	.28	.19	
37VC650 27.56	10.000	7.688	9.000	7.9	8.4	49.250	6.000	1/2-14 NPT	8.562	.28	.19	
42VC650 29.56	11.000	7.688	10.000	8.2	9.0	54.250	6.000	1/2-14 NPT	8.562	.28	.19	

SI Size	(Dimensions in millimeters)										Clearance for "Drop Out"	
	D	D ₁	D ₂	D ₇	D ₃₇	D ₃₈	H	M	O	X	Element	Drum
11.5VC50006.09	110	156	127	135	140	508	1	2	171	6,8	3,1	
14VC500 459	140	156	146	152	147	610	37	1/8-18 NPT	173	6,3	4,8	
16VC600 490	140	187	146	157	165	660	37	1/8-18 NPT	205	6,3	4,8	
20VC600 522	152	187	165	152	175	762	37	1/8-18 NPT	205	6,3	4,8	
24VC650 548	165	195	165	168	183	880	37	1/8-18 NPT	217	9,1	4,8	
28VC650 624	203	195	203	175	201	981	127	1/2-14 NPT	217	9,1	4,8	
33VC650 675	229	195	229	191	211	1149	127	1/2-14 NPT	217	7,1	4,8	
37VC650 700	254	195	229	201	213	1251	152	1/2-14 NPT	217	7,1	4,8	
42VC650 751	279	195	254	208	229	1378	152	1/2-14 NPT	217	7,1	4,8	

1 M(in)=0.268 (H/2-radius of bore) +0.34 M(mm)=0.268 (H/2-radius of bore) +8,7
2 Pipe tap not required. Thru hole diameter 0.44 in (11 mm).

Airflex® VC Clutch Application
 Form VC 508 — Dual NarrowSeries

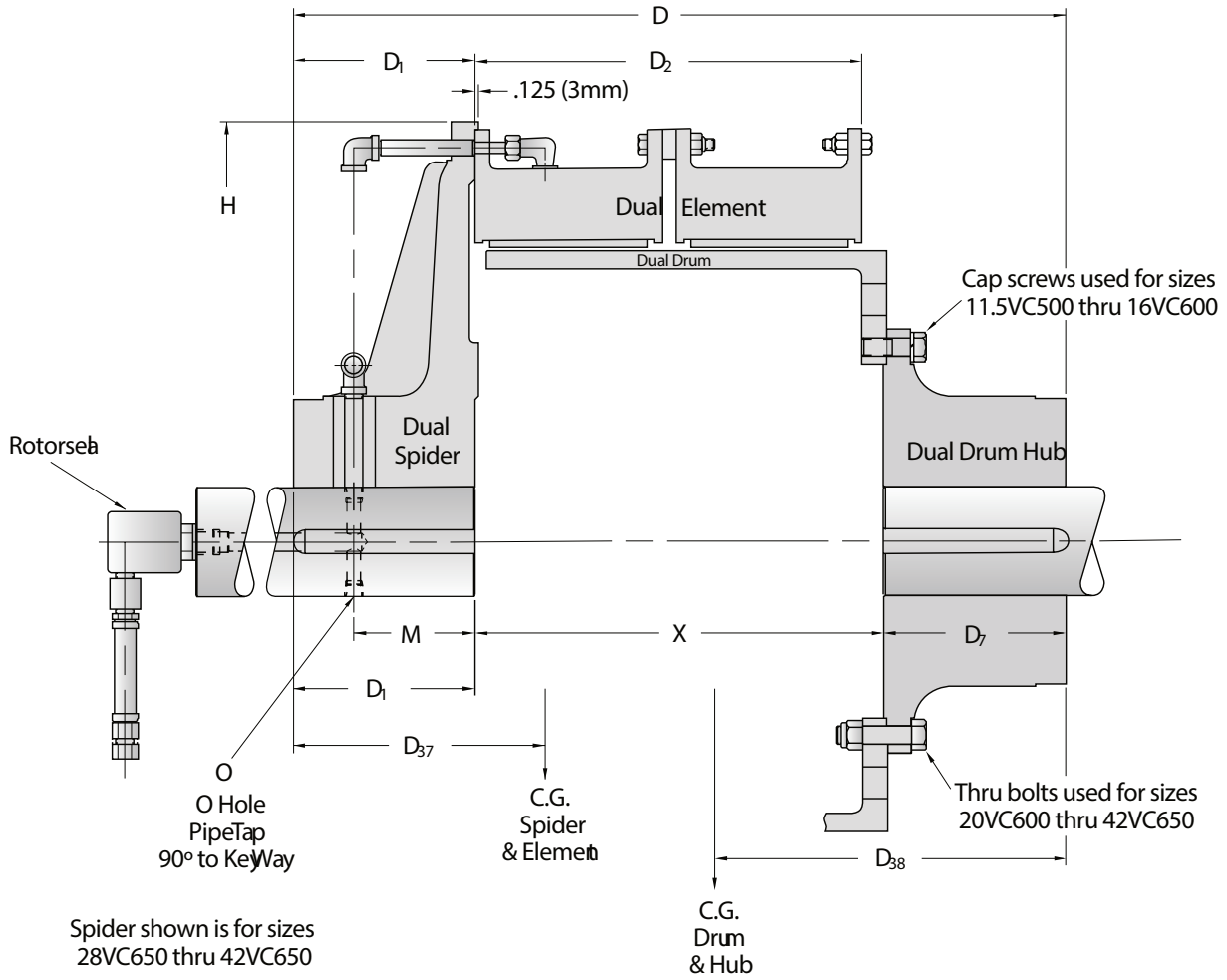

ENGL ISH

Size	Basic B/M	Torque Rating (lb-ins) at 75 PSI	Weight (lbs)	Bore Range (inches)			
				Spider Min.	Max.	Hub Min.	Max.
11.5VC50004610		54,000	393	3.000	4.000	3.000	4.000
14VC500 104611		78,400	559	3.500	4.750	3.500	4.750
16VC600 104612		130,000	800	4.250	6.000	4.250	5.000
20VC600 104613		186,000	1016	4.750	6.000	4.750	6.000
24VC650 104614		270,000	1413	5.250	7.500	5.250	7.500
28VC650 104615		364,000	1759	5.750	8.500	5.750	8.500
33VC650 104616		510,000	2488	6.500	9.000	6.500	9.000
37VC650 104617		640,000	2933	7.000	9.500	7.000	9.500
42VC650 104618		760,000	3407	7.500	10.500	7.500	10.500

SI

Size	Basic B/M	Torque Rating (N-m) at 5,2 bar	Mass (kg)	Bore Range (millimeters)			
				Spider Min.	Max.	Hub Min.	Max.
11.5VC50004610		6,100	178	76	102	76	102
14VC500 104611		8,860	253	89	121	89	121
16VC600 104612		14,690	362	108	152	108	152
20VC600 104613		21,010	460	121	152	121	152
24VC650 104614		30,500	640	133	191	133	191
28VC650 104615		41,125	797	146	216	146	216
33VC650 104616		57,620	1127	165	229	165	229
37VC650 104617		72,310	1329	178	241	178	241
42VC650 104618		85,870	1543	191	267	191	267

ENGL ISH

Size	(Dimensions in inches)										Clearance for Drop Out	
	D	D ₁	D ₂	D ₇	D ₃₇	D ₃₈	H	M	O	X	Element	Drum
11.5VC500	25.22	4.844	12.750	5.000	8.8	9.4	20.000	1	2	13.375	.27	.12
14VC500	24.69	5.500	12.688	5.750	9.2	8.9	24.000	1.438	½-14 NPT	13.438	.31	.19
16VC600	27.94	5.500	15.188	6.500	9.6	9.7	26.000	4.000	½-14 NPT	15.938	.31	.19
20VC600	29.94	7.000	15.188	7.000	10.2	9.7	30.000	5.000	½-14 NPT	15.938	.31	.19
24VC650	31.69	7.500	15.938	7.500	10.1	9.9	34.625	5.000	¾-14 NPT	16.688	.23	.19
28VC650	32.69	8.000	15.938	8.000	10.7	11.0	38.625	5.000	¾-14 NPT	16.688	.23	.19
33VC650	35.25	9.000	15.938	9.500	11.1	11.2	45.250	5.000	¾-14 NPT	16.750	.22	.19
37VC650	36.75	10.000	15.938	10.000	11.8	11.5	49.250	6.000	¾-14 NPT	16.750	.22	.19
42VC650	38.75	11.000	15.938	11.000	8.6	9.8	54.250	6.000	¾-14 NPT	16.750	.22	.19

SI

Size	(Dimensions in millimeters)										Clearance for Drop Out	
	D	D ₁	D ₂	D ₇	D ₃₇	D ₃₈	H	M	O	X	Element	Drum
11.5VC500	641	123	324	127	224	239	508	1	2	340	6,7	3,2
14VC500	627	140	322	146	234	226	610	37	½-14 NPT	341	7,9	4,8
16VC600	710	140	386	165	244	246	660	102	½-14 NPT	405	7,9	4,8
20VC600	760	178	386	178	259	246	762	127	½-14 NPT	405	7,9	4,8
24VC650	805	191	405	191	257	251	880	127	¾-14 NPT	424	5,9	4,8
28VC650	830	203	405	203	272	279	981	127	¾-14 NPT	424	5,9	4,8
33VC650	895	229	405	241	282	284	1149	127	¾-14 NPT	425	5,6	4,8
37VC650	933	254	405	254	300	292	1251	152	¾-14 NPT	425	5,6	4,8
42VC650	984	279	405	279	218	249	1378	152	¾-14 NPT	425	5,6	4,8

1 M(in)=0.268 (H/2-radius of bore) +0.34 M(mm)=0,268 (H/2-radius of bore) +8,7

2 Pipe tap not required. Thru hole diameter 0.44 in (11 mm).

Airflex® VC Clutch Application
 FORM VC508 (LA-7132) — Dual NarrowSeries
 with Locking Assembly

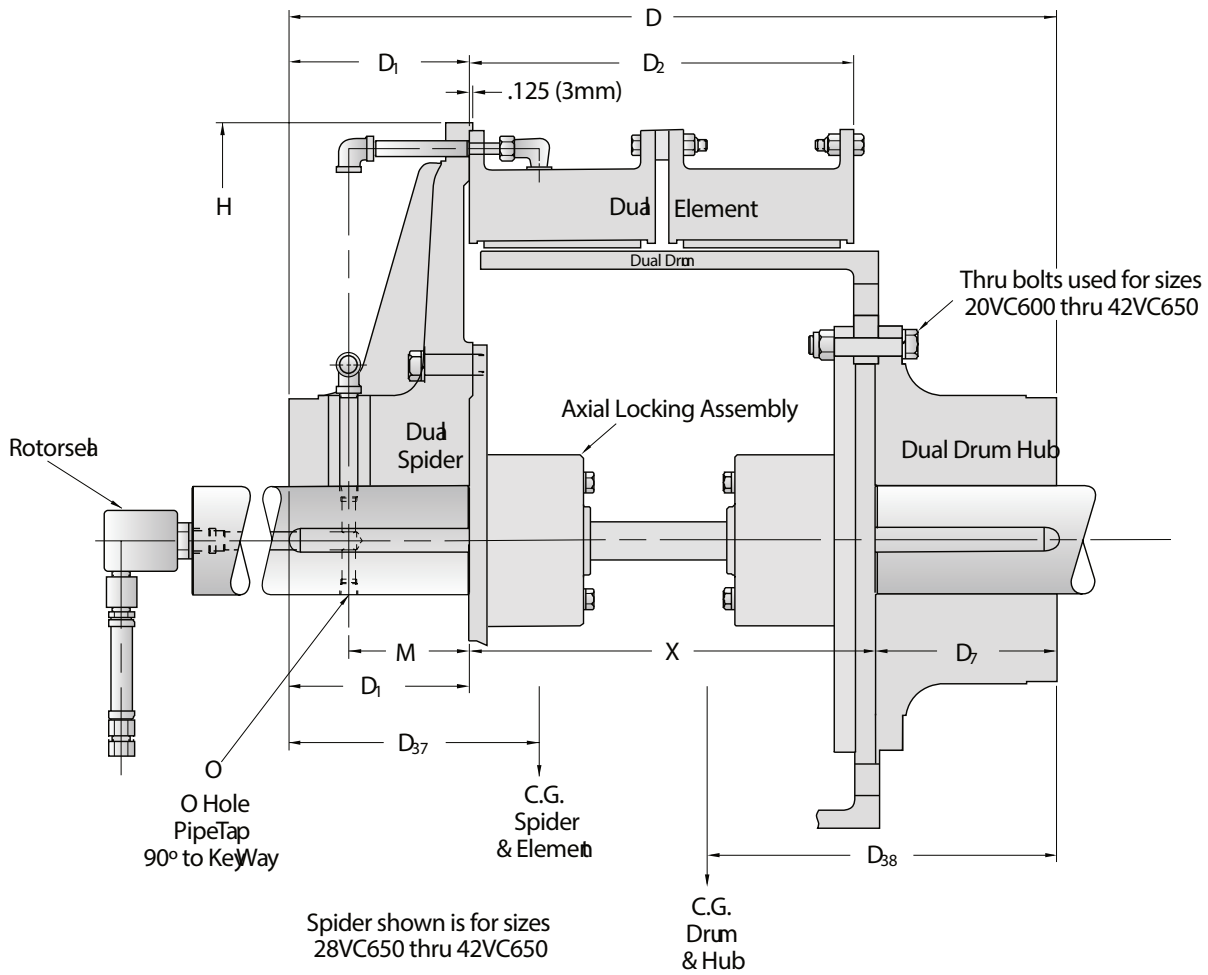

ENGL ISH

Size	Basic B/M	Torque Rating (lb-ins) at 75 PSI	Weight (lbs)	Bore Range (inches)		Hub Min.	Hub Max.
				Spider Min.	Max.		
20VC600	104620	186,000	1,126	4.750	6.000	4.750	6.000
24VC650	104621	270,000	1,539	5.250	7.500	5.250	7.500
28VC650	104622	364,000	1,949	5.750	8.500	5.750	8.500
33VC650	104623	510,000	2,655	6.500	9.000	6.500	9.000
37VC650	104624	640,000	3,135	7.000	9.500	7.000	9.500
42VC650	104625	760,000	3,677	7.500	10.500	7.500	10.500

SI

Size	Basic B/M	Torque Rating (N-m) at 5,2 bar	Mass (kg)	Bore Range (millimeters)		Hub Min.	Hub Max.
				Spider Min.	Max.		
20VC600	104620	21,010	511	121	152	121	152
24VC650	104621	30,500	698	133	191	133	191
28VC650	104622	41,120	884	146	216	146	216
33VC650	104623	57,620	1204	165	229	165	229
37VC650	104624	72,310	1422	178	241	178	241
42VC650	104625	85,870	1668	191	267	191	267

ENGL ISH

Size	(Dimensions in inches)										Clearance for "Drop Out" Moving Shafts .250 Apart Locking Assembly and Drum	Element
	D	D ₁	D ₂	D ₇	D ₃₇	D ₃₈	H	M	O	X		
20VC600	29.94	7.000	15.188	7.000	Consult	Factory	30.000	5.000	1/2-14 NPT	15.938	.12	.56
24VC650	31.69	7.500	15.938	7.500	Consult	Factory	34.625	5.000	3/4-14 NPT	16.688	.12	.48
28VC650	32.69	8.000	15.938	8.000	Consult	Factory	38.625	5.000	3/4-14 NPT	16.688	.12	.48
33VC650	35.25	9.000	15.938	9.500	Consult	Factory	45.250	5.000	3/4-14 NPT	16.750	.12	.47
37VC650	36.75	10.000	15.938	10.000	Consult	Factory	49.250	6.000	3/4-14 NPT	16.750	.12	.47
42VC650	38.75	11.000	15.938	11.000	Consult	Factory	54.250	6.000	3/4-14 NPT	16.750	.12	.47

SI

Size	(Dimensions in millimeters)										Clearance for "Drop Out" Moving Shafts .635 Apart Locking Assembly and Drum	Element
	D	D ₁	D ₂	D ₇	D ₃₇	D ₃₈	H	M	O	X		
20VC600	760	178	386	178	Consult	Factory	762	127	1/2-14 NPT	405	3,2	14,2
24VC650	805	191	405	191	Consult	Factory	880	127	3/4-14 NPT	424	3,2	12,3
28VC650	830	203	405	203	Consult	Factory	981	127	3/4-14 NPT	424	3,2	12,3
33VC650	895	229	405	229	Consult	Factory	1149	127	3/4-14 NPT	425	3,2	11,9
37VC650	933	254	405	254	Consult	Factory	1251	152	3/4-14 NPT	425	3,2	11,9
42VC650	984	279	405	279	Consult	Factory	1378	152	3/4-14 NPT	425	3,2	11,9

Airflex® VC Clutch Application

Form VC 509 — Single Wide Series

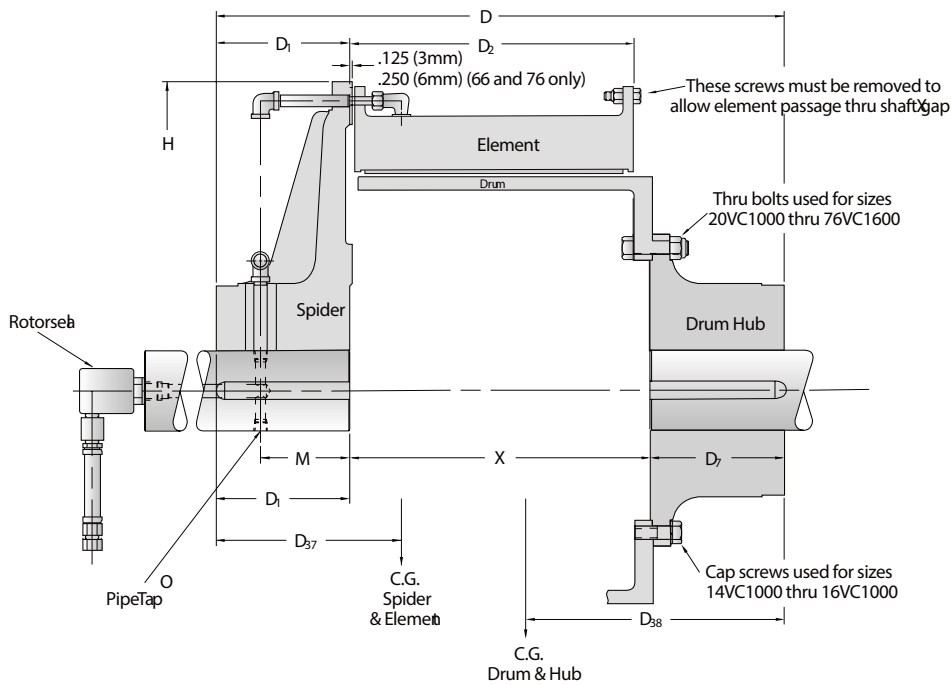

ENGLISH				Bore Range (inches)			
Size	Basic B/M	Torque Rating (lb-ins) at 75 PSI	Weight (lbs)	Spider Min.	Spider Max.	Hub Min.	Hub Max.
14VC1000	104979	85,000	610	3.625	5.000	3.625	5.000
16VC1000	104680	114,000	731	3.875	6.000	3.875	6.000
20VC1000	104681	161,000	896	4.500	6.250	4.500	6.250
24VC1000	104682	219,000	1,226	5.000	8.000	5.000	8.000
28VC1000	104683	296,000	1,577	5.500	8.500	5.500	8.500
32VC1000	104684	415,000	2,129	6.000	9.000	6.000	9.000
38VC1200	104685	680,000	2,759	7.250	9.250	7.250	9.250
42VC1200	104686	819,000	3,270	7.500	10.000	7.500	10.000
46VC1200	104687	950,000	4,026	8.000	10.000	8.000	10.000
52VC1200	104688	1,215,000	5,748	8.750	11.000	8.750	11.000
51VC1600	104689	1,610,000	6,920	9.500	12.500	9.500	12.500
60VC1600	104690	2,183,000	10,712	10.500	18.000	10.500	18.000
66VC1600	—	—	Consult Factory	—	—	—	—
76VC1600	—	—	Consult Factory	—	—	—	—

SI				Bore Range (millimeters)			
Size	Basic B/M	Torque Rating (N-m) at 5,2 bar	Mass (kg)	Spider Min.	Spider Max.	Hub Min.	Hub Max.
14VC1000	104979	9605	276	92	127	92	127
16VC1000	104680	12880	331	98	152	98	152
20VC1000	104681	18,190	406	114	159	114	159
24VC1000	104682	24,745	555	127	203	127	203
28VC1000	104683	33,445	714	140	216	140	216
32VC1000	104684	46,890	965	152	229	152	229
38VC1200	104685	76,830	1250	184	235	184	235
42VC1200	104686	92,535	1482	191	254	191	254
46VC1200	104687	107,335	1824	203	254	203	254
52VC1200	104688	137,275	2604	222	279	222	279
51VC1600	104689	181,905	3135	241	318	241	318
60VC1600	104690	246,645	4854	267	457	267	457
66VC1600	—	—	Consult Factory	—	—	—	—
76VC1600	—	—	Consult Factory	—	—	—	—

ENGL ISH

Size	D	(Dimensions in inches)						H	M	O	X	Clearance for "Drop Out"	
		D ₁	D ₂	D ₇	D ₃₇	D ₃₈	Element					Drum	
14VC1000	24.38	5.500	11.562	7.000	7.0	8.8	24.000	4.000	⅝-18 NPT	11.875	.19	.25	
16VC1000	22.88	5.500	11.562	5.500	6.7	6.6	26.000	4.000	⅝-18 NPT	11.875	.19	.25	
20VC1000	25.88	7.000	11.562	7.000	7.5	8.1	30.000	5.000	⅝-18 NPT	11.875	.19	.25	
24VC1000	26.88	7.500	11.562	7.500	7.9	8.3	34.625	5.000	½-14 NPT	11.875	.19	.25	
28VC1000	27.88	8.000	11.562	8.000	8.0	8.7	38.625	5.000	½-14 NPT	11.875	.19	.25	
32VC1000	30.44	9.000	11.625	9.500	9.1	9.6	44.500	5.000	½-14 NPT	11.938	.19	.31	
38VC1200	34.12	10.000	13.750	10.000	9.5	10.6	50.000	6.000	½-14 NPT	14.125	.25	.38	
42VC1200	36.12	11.000	13.750	11.000	10.6	11.0	54.250	6.000	½-14 NPT	14.125	.25	.38	
46VC1200	36.12	11.000	13.750	11.000	10.0	11.3	61.000	6.000	½-14 NPT	14.125	.25	.38	
52VC1200	39.62	12.500	14.250	12.500	10.3	12.3	67.750	7.000	¾-14 NPT	14.625	.25	.62	
51VC1600	48.88	15.000	18.250	15.000	13.9	14.3	67.750	7.000	¾-14 NPT	18.875	.50	.62	
60VC1600	50.75	16.000	18.500	16.000	14.2	15.2	77.750	7.000	1"-11 ½ NPT	18.750	.12	.88	

SI

Size	D	(Dimensions in millimeters)						H	M	O	X	Clearance for "Drop Out"	
		D ₁	D ₂	D ₇	D ₃₇	D ₃₈	Element					Drum	
14VC1000	619	140	294	178	178	224	610	102	⅝-18 NPT	302	4,8	6,3	
16VC1000	581	140	294	140	170	168	660	102	⅝-18 NPT	302	4,8	6,3	
20VC1000	657	178	294	178	191	206	762	127	⅝-18 NPT	302	4,8	6,3	
24VC1000	683	191	294	191	201	211	880	127	½-14 NPT	302	4,8	6,3	
28VC1000	708	203	294	203	203	221	981	127	½-14 NPT	302	4,8	6,3	
32VC1000	773	229	295	241	231	244	1130	127	½-14 NPT	303	4,8	7,9	
38VC1200	867	254	349	254	241	269	1270	152	½-14 NPT	359	6,3	9,5	
42VC1200	918	279	349	279	269	279	1378	152	½-14 NPT	359	6,3	9,5	
46VC1200	918	279	349	279	254	287	1549	152	½-14 NPT	359	6,3	9,5	
52VC1200	1007	318	362	318	262	312	1721	178	¾-14 NPT	372	6,3	15,9	
51VC1600	1242	381	464	381	353	363	1721	178	¾-14 NPT	480	12,7	15,9	
60VC1600	1289	406	470	406	361	386	1975	178	1"-11 ½ NPT	476	3,2	22,2	

Airflex® VC Clutch Application

FORM VC509 (LA-7134) — Single Wide Series

with Locking Assembly

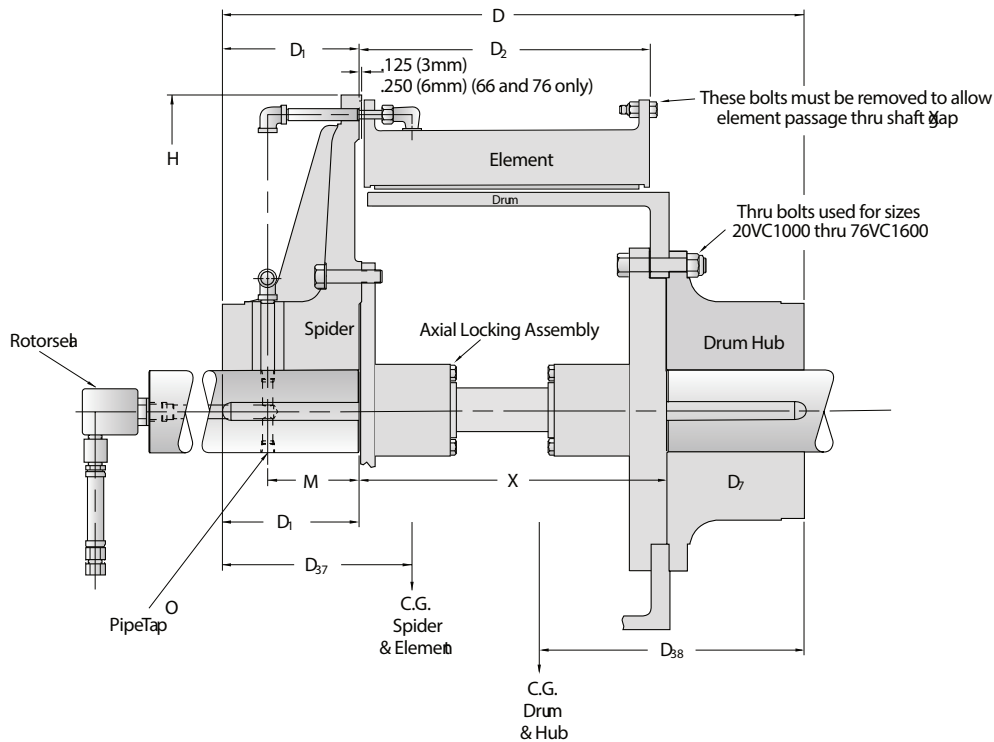

ENGLISH				Bore Range (inches)			
Size	Basic B/M	Torque Rating (lb-ins) at 75 PSI	Weight (lbs)	Spider Min.	Spider Max.	Hub Min.	Hub Max.
20VC1000	104700	161,000	1,006	4.500	6.250	4.500	6.250
24VC1000	104701	219,000	1,345	5.000	8.000	5.000	8.000
28VC1000	104702	296,000	1,714	5.500	8.500	5.500	8.500
32VC1000	104703	415,000	2,279	6.000	9.000	6.000	9.000
38VC1200	104704	680,000	2,964	7.250	9.250	7.250	9.250
42VC1200	104705	819,000	3,506	7.500	10.000	7.500	10.000
46VC1200	104706	950,000	4,302	8.000	10.000	8.000	10.000
52VC1200	104707	1,215,000	5,997	8.750	11.000	8.750	11.000
51VC1600	104708	1,610,000	7,233	9.500	12.500	9.500	12.500
60VC1600	104709	2,183,000	11,315	10.500	18.000	10.500	18.000

SI				Bore Range (millimeters)			
Size	Basic B/M	Torque Rating (N-m) at 5.2 bar	Spider Mass (kg)	Hub Min.	Hub Max.	Min.	Max.
20VC1000	104700	18,190	456	114	159	114	159
24VC1000	104701	24,745	610	127	203	127	203
28VC1000	104702	33,445	777	140	216	140	216
32VC1000	104703	46,890	1034	152	229	152	229
38VC1200	104704	76,830	1344	184	235	184	235
42VC1200	104705	92,535	1590	191	254	191	254
46VC1200	104706	107,335	1951	203	254	203	254
52VC1200	104707	137,275	2217	222	279	222	279
51VC1600	104708	181,905	3227	241	318	241	318
60VC1600	104709	246,645	5127	267	457	267	457

ENGLISH

Size	(Dimensions in inches)						H	M	O	X	Clearance for "Drop Out" Moving Shafts .250 Apart Locking Assembly	Element
	D	D ₁	D ₂	D ₇	D ₃₇	D ₃₈						
20VC1000	25.88	7.000	11.562	7.000	Consult	Factory	30.000	5.000	⅝-18 NPT	11.875	.12	.44
24VC1000	26.88	7.500	11.562	7.500	Consult	Factory	34.625	5.000	½-14 NPT	11.875	.12	.44
28VC1000	27.88	8.000	11.562	8.000	Consult	Factory	38.625	5.000	½-14 NPT	11.875	.12	.44
32VC1000	30.44	9.000	11.625	9.500	Consult	Factory	44.500	5.000	½-14 NPT	11.938	.12	.44
38VC1200	34.12	10.000	13.750	10.000	Consult	Factory	50.000	6.000	½-14 NPT	14.125	.12	.50
42VC1200	36.12	11.000	13.750	11.000	Consult	Factory	54.250	6.000	½-14 NPT	14.125	.12	.50
46VC1200	36.12	11.000	13.750	11.000	Consult	Factory	61.000	6.000	½-14 NPT	14.125	.12	.50
52VC1200	39.62	12.500	14.250	12.500	Consult	Factory	67.750	7.000	¾-14 NPT	14.625	.12	.50
51VC1600	48.88	15.000	18.250	15.000	Consult	Factory	67.750	7.000	¾-14 NPT	18.875	.12	.75
60VC1600	50.75	16.000	18.500	16.000	Consult	Factory	77.750	7.000	1"-11 ½ NPT	18.750	.12	.38

Size	(Dimensions in millimeters)						H	M	O	X	Clearance for "Drop Out" Moving Shafts 6,35 Apart Locking Assembly	Element
	D	D ₁	D ₂	D ₇	D ₃₇	D ₃₈						
20VC1000	657	178	294	178	Consult	Factory	762	127	⅝-18 NPT	302	3,1	11,1
24VC1000	683	191	294	191	Consult	Factory	880	127	½-14 NPT	302	3,1	11,1
28VC1000	708	203	294	203	Consult	Factory	981	127	½-14 NPT	302	3,1	11,1
32VC1000	773	229	295	241	Consult	Factory	1130	127	½-14 NPT	303	3,1	11,1
38VC1200	867	254	349	254	Consult	Factory	1270	152	½-14 NPT	359	3,1	12,7
42VC1200	918	279	349	279	Consult	Factory	1378	152	½-14 NPT	359	3,1	12,7
46VC1200	918	279	349	279	Consult	Factory	1549	152	½-14 NPT	359	3,1	12,7
52VC1200	1007	318	362	318	Consult	Factory	1721	178	¾-14 NPT	372	3,1	12,7
51VC1600	1242	381	464	381	Consult	Factory	1721	178	¾-14 NPT	480	3,1	19,1
60VC1600	1289	406	470	406	Consult	Factory	1975	178	1"-11 ½ NPT	476	3,1	9,5

Airflex® VC Clutch Application

Form VC 510 — Dual Wide Series

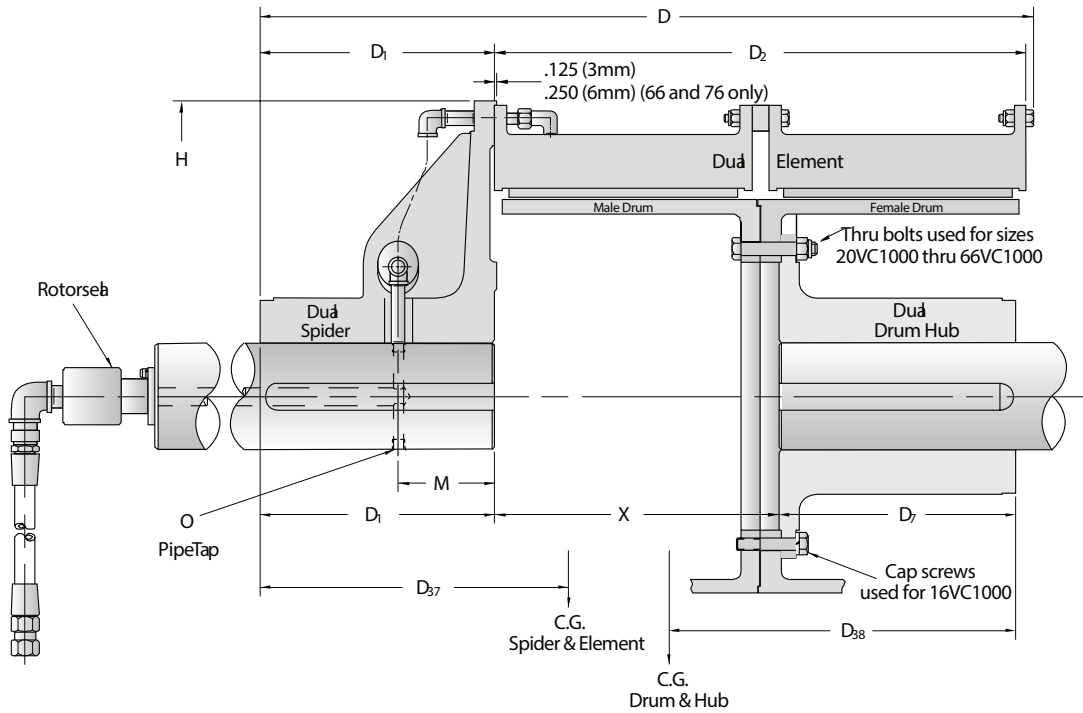

ENGLISH

Size	Basic B/M	Torque Rating (lb.-ins) at 75 PSI	Weight (lbs)	Bore Range (inches)		Hub	
				Spider Min.	Max.	Min.	Max.
16VC1000	104720	228,000	1,085	5.000	6.000	5.000	6.000
20VC1000	104721	322,000	1,440	5.500	6.500	5.500	6.500
24VC1000	104722	438,000	1,910	6.250	7.250	6.250	7.250
28VC1000	104723	592,000	2,490	6.750	8.000	6.750	8.000
32VC1000	104724	830,000	3,510	7.750	10.500	7.750	10.500
38VC1200	104725	1,360,000	4,610	9.000	11.000	9.000	11.000
42VC1200	104726	1,638,000	5,920	9.500	11.750	9.500	11.750
46VC1200	104727	1,900,000	6,560	10.000	12.500	10.000	12.500
52VC1200	104728	2,430,000	8,715	10.750	14.000	10.750	14.000
51VC1600	104729	3,220,000	11,560	12.000	15.500	12.000	15.500
60VC1600	104730	4,366,000	17,675	13.250	20.000	13.250	20.000
66VC1600	Consult Factory	5,600,000	22,960	15.000	22.000	15.000	22.000
76VC1600	Consult Factory	7,320,000	27,450	16.250	24.000	16.250	24.000
76VC2000	Consult Factory	9,300,000	30,255	16.250	24.000	16.250	24.000

SI

Size	Basic B/M	Torque Rating (N-m) at 5,2 bar	Mass (kgs)	Bore Range (millimeters)		Hub	
				Spider Min.	Max.	Min.	Max.
16VC1000	104720	25,760	492	127	152	127	152
20VC1000	104721	36,380	652	140	165	140	165
24VC1000	104722	49,490	865	159	184	159	184
28VC1000	104723	66,890	1,128	172	203	172	203
32VC1000	104724	93,780	1,590	197	267	197	267
38VC1200	104725	153,660	2,088	229	279	229	279
42VC1200	104726	185,070	2,682	241	299	241	299
46VC1200	104727	214,670	2,972	254	318	254	318
52VC1200	104728	274,550	3,948	273	356	273	356
51VC1600	104729	363,810	5,237	305	394	305	394
60VC1600	104730	493,290	8,007	337	508	337	508
66VC1600	Consult Factory	632,710	10,401	381	559	381	559
76VC1600	Consult Factory	827,050	12,438	413	610	413	610
76VC2000	Consult Factory	1,05,0759	13,723	413	610	413	610

ENGLISH

Size	D	D ₁	D ₂	D ₇	D ₃₇	D ₃₈	H	M	O	X	Clearance "Drop Out" Element	Drum
16VC1000	32.00	8.000	23.688	10.000	14.0	13.8	26.000	4.000	½-14 NPT	12.750	.19	.25
20VC1000	33.59	9.500	23.688	9.500	15.3	14.8	30.000	5.000	½-14 NPT	12.750	.19	.25
24VC1000	33.39	9.312	23.688	9.500	15.1	15.0	34.625	5.000	¾-14 NPT	12.750	.19	.25
28VC1000	34.08	10.000	23.688	10.000	14.5	15.3	38.625	5.000	¾-14 NPT	12.750	.19	.25
32VC1000	36.20	12.000	23.812	12.000	16.5	15.9	44.500	5.000	¾-14 NPT	12.812	.19	.31
38VC1200	41.53	13.000	28.062	13.000	17.0	18.0	50.000	6.000	¾-14 NPT	15.000	.25	.38
42VC1200	45.53	17.000	28.062	17.000	20.0	19.7	54.250	6.000	¾-14 NPT	15.125	.25	.38
46VC1200	45.61	17.000	28.062	17.000	20.3	20.8	61.000	6.000	¾-14 NPT	15.250	.25	.38
52VC1200	46.61	17.000	29.062	17.000	19.5	19.9	67.750	7.000	1"-11 ½ NPT	15.750	.25	.63
51VC1600	57.61	20.000	37.062	20.000	27.0	23.0	67.750	7.000	1"-11 ½ NPT	20.000	.50	.63
60VC1600	62.17	24.000	37.562	24.000	27.8	26.0	77.750	7.000	1¼-11 ½ NPT	20.375	.12	.88
66VC1600	70.00	CF	37.000	24.000	31.5	22.0	82.500	Consult Factory	1¼-11 ½ NPT	22.000	.25	.63
76VC1600	74.38	26.750	37.000	27.000	27.6	20.0	93.000	11.630	1¼-11½ NPT	20.370	.38	.88
76VC2000	78.39	26.750	27.000	24.020	30.8	20.7	93.000	11.630	1¼-11 ½ NPT	24.370	.38	.88

SI

Size	D	D ₁	D ₂	D ₇	D ₃₇	D ₃₈	H	M	O	X	Clearance "Drop Out" Element	Drum
16VC1000	813	203	602	254	356	351	660	102	½-14 NPT	324	4,8	6,3
20VC1000	853	241	602	241	389	376	762	127	½-14 NPT	324	4,8	6,3
24VC1000	848	236	602	241	384	381	880	127	¾-14 NPT	324	4,8	6,3
28VC1000	866	254	602	254	368	389	981	127	¾-14 NPT	324	4,8	6,3
32VC1000	919	305	605	305	419	404	1130	127	¾-14 NPT	325	4,8	7,9
38VC1200	1055	330	713	330	432	457	1270	152	¾-14 NPT	381	6,3	9,5
42VC1200	1156	432	713	432	508	500	1378	152	¾-14 NPT	384	6,3	9,5
46VC1200	1158	432	713	432	516	528	1549	152	¾-14 NPT	387	6,3	9,5
52VC1200	1184	432	738	432	495	505	1721	178	1"-11 ½ NPT	400	6,3	15,9
51VC1600	1463	508	941	508	686	584	1721	178	1"-11 ½ NPT	508	12,7	15,9
60VC1600	1579	610	954	610	706	660	1975	178	1¼-11 ½ NPT	518	3,2	22,2
66VC1600	1778	610	940	610	800	559	2096	229	1¼-11 ½ NPT	559	6,3	15,9
76VC1600	1889	680	940	686	701	508	2362	296	1¼-11½ NPT	517	9,5	22,2
76VC2000	1991	680	1143	686	782	526	2362	295	1¼-11 ½ NPT	619	9,5	22,2

Airflex® VC Clutch Application

FORM VC510 (LA-7136) — Dual Wide Series

with Locking Assembly

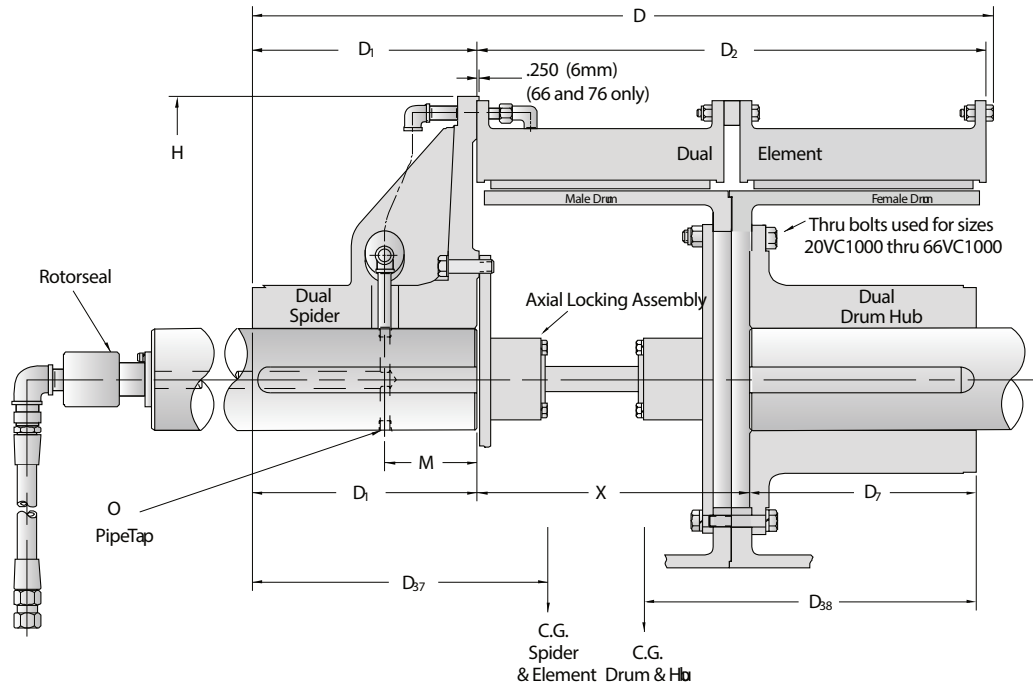

ENGLISH				Bore Range (inches)			
Size	Basic B/M	Torque Rating (lb-ins) at 75 PSI	Weight (lbs)	Spider		Hub	
				Min.	Max.	Min.	Max.
20VC1000	104740	322,000	1,577	5.500	6.500	5.500	6.500
24VC1000	104741	438,000	2,071	6.250	7.250	6.250	7.250
28VC1000	104742	592,000	2,641	6.750	8.000	6.750	8.000
32VC1000	104743	830,000	3,775	7.750	10.500	7.750	10.500
38VC1200	104744	1,360,000	4,790	9.000	11.000	9.000	11.000
42VC1200	104745	1,638,000	6,095	9.500	11.750	9.500	11.750
46VC1200	104746	1,900,000	6,754	10.000	12.500	10.000	12.500
52VC1200	104747	2,430,000	9,178	10.750	14.000	10.750	14.000
51VC1600	104748	3,220,000	12,095	12.000	15.500	12.000	15.500
60VC1600	104749	4,366,000	18,855	13.250	20.000	13.250	20.000
66VC1600	108002	5,600,000	23,054	15.000	22.000	15.000	22.000
76VC1600	108082	7,320,000	27,750	16.250	24.000	16.250	24.000
76VC2000	108120	9,300,000	30,565	16.250	24.000	16.250	24.000

SI				Bore Range (millimeters)			
Size	Basic B/M	Torque Rating (N-m) at 5,2 bar	Mass (kgs)	Spider		Hub	
				Min.	Max.	Min.	Max.
20VC1000	104740	36,380	715	140	165	140	165
24VC1000	104741	49,490	939	159	184	159	184
28VC1000	104742	66,890	1198	172	203	172	203
32VC1000	104743	93,780	1710	197	267	197	267
38VC1200	104744	153,660	2170	229	279	229	279
42VC1200	104745	185,070	2762	241	299	241	299
46VC1200	104746	214,670	3060	254	318	254	318
52VC1200	104747	274,550	4158	273	356	273	356
51VC1600	104748	363,810	5480	305	394	305	394
60VC1600	104749	493,290	8543	337	508	337	508
66VC1600	106972	632,710	10445	381	559	381	559
76VC1600	108082	827,050	12574	413	610	413	610
76VC2000	108120	1,050,760	13,864	413	610	413	610

ENGLISH

Size	(Dimensions in inches)								O	X	Clearance for "Drop Out"		Element
	D	D ₁	D ₂	D ₇	D ₃₇	D ₃₈	H	M			Drum &	Locking Assembly	
20VC1000	33.59	9.500	23.688	9.500	15.0	10.9	30.000	5.000	½-14 NPT	12.750	.12		.44
24VC1000	33.39	9.312	23.688	9.500	15.7	10.5	34.625	5.000	¾-14 NPT	12.750	.12		.44
28VC1000	34.08	10.000	23.688	10.000	15.4	10.9	38.625	5.000	¾-14 NPT	12.750	.12		.44
32VC1000	36.20	12.000	23.812	12.000	17.1	12.0	44.500	5.000	¾-14 NPT	12.812	.12		.44
38VC1200	41.53	13.000	28.062	13.000	18.2	12.6	50.000	6.000	¾-14 NPT	15.000	.12		.50
42VC1200	45.53	17.000	28.062	17.000	21.6	15.1	54.250	6.000	¾-14 NPT	15.125	.12		.50
46VC1200	45.61	17.000	28.062	17.000	21.7	15.6	61.000	6.000	¾-14 NPT	15.250	.12		.50
52VC1200	46.61	17.000	29.062	17.000	20.9	15.1	67.750	7.000	1"-11 ½ NPT	15.750	.12		.50
51VC1600	57.61	20.000	37.062	20.000	26.4	15.7	67.750	7.000	1"-11 ½ NPT	20.000	.12		.75
60VC1600	62.17	24.000	37.562	24.000	28.5	20.8	77.750	7.000	1¼-11 ½ NPT	20.375	.12		1.00
66VC1600	70.00	Consult Factory	37.000	24.000	28.0	19.2	82.500	Consult Factory	1¼-11 ½ NPT	22.000	.25		.88
76VC1600	74.39	26.750	37.000	27.000	27.6	20.5	93.000	11.630	1¼-11 ½ NPT	20.370	.25		1.00
76VC2000	78.39	26.75	45.000	27.000	30.8	21.2	93.500	11.630	1¼-11 ½ NPT	24.370	.25		1.00

SI

Size	(Dimensions in millimeters)								O	X	Clearance for "Drop Out"		Element
	D	D ₁	D ₂	D ₇	D ₃₇	D ₃₈	H	M			Drum &	Locking Assembly	
20VC1000	853	241	602	241	381	277	762	127	½-14 NPT	324	3,2		11,1
24VC1000	848	236	602	241	399	267	880	127	¾-14 NPT	324	3,2		11,1
28VC1000	866	254	602	254	391	277	981	127	¾-14 NPT	324	3,2		11,1
32VC1000	919	305	605	305	434	305	1130	127	¾-14 NPT	325	3,2		11,1
38VC1200	1055	330	713	330	462	320	1270	152	¾-14 NPT	381	3,2		12,7
42VC1200	1156	432	713	432	549	384	1378	152	¾-14 NPT	384	3,2		12,7
46VC1200	1158	432	713	432	551	396	1549	152	¾-14 NPT	387	3,2		12,7
52VC1200	1184	432	738	432	531	384	1721	178	1"-11 ½ NPT	400	3,2		12,7
51VC1600	1463	508	941	508	671	399	1721	178	1"-11 ½ NPT	508	3,2		19,0
60VC1600	1579	610	954	610	724	528	1975	178	1¼-11 ½ NPT	518	3,2		25,4
66VC1600	1778	Consult Factory	940	610	711	488	2096	Consult Factory	1¼-11 ½ NPT	559	6,3		22,2
76VC1600	1889	680	940	686	701	521	2362	296	1¼-11 ½ NPT	517	6,3		25,4
76VC2000	1991	680	1143	686	782	539	2362	295	1¼-11 ½ NPT	619	6,3		25,4

Airflex® Single Narrow VC Elements

Form VC-501 Sizes 11.5 to 42

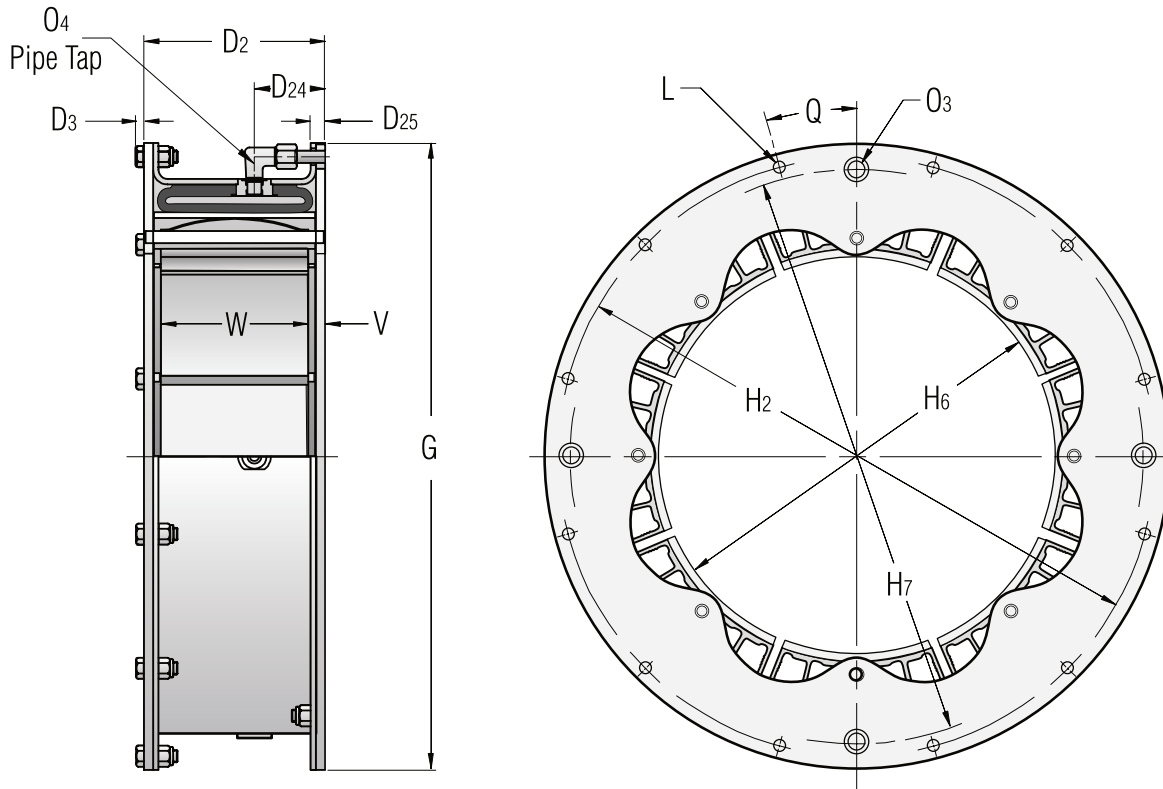

ENGLISH

Size	MrTorque Part Number	Rating (lb-in @ 75 psi)	Maximum Speed (rpm)	C _s Centrifugal loss (psi/rpm ²)	Wk ² (lb-ft ²)	Weight (lb)	Friction Area (in ²)	Friction Lining Thickness (inches)	Worn	AirTube Cavity (in ³)	Minimum Drum Diameter (inches)
11.5VC500	142639	27,000	1800	23 E-06	43	96	166	0.32	0.16	70	11.41
14VC500	143829	39,200	1500	28 E-06	78	128	205	0.32	0.16	95	13.91
16VC600	142640	65,000	1400	29 E-06	115	151	283	0.32	0.16	120	15.91
20VC600	142641	93,000	1200	40 E-06	193	179	380	0.32	0.16	140	19.88
24VC650	142642	135,000	1050	49 E-06	369	246	466	0.44	0.16	200	23.88
28VC650	142643	182,000	1000	58 E-06	537	280	548	0.44	0.16	270	27.81
33VC650	142644	255,000	900	74 E-06	1083	392	643	0.57	0.28	360	32.81
37VC650	142645	320,000	800	90 E-06	1400	433	720	0.57	0.28	400	36.81
42VC650	142647	380,000	800	95 E-06	1990	485	822	0.57	0.28	440	41.81

SI

Size	Part Number	MrTorque Rating (N·m @ 5.2 bar)	Maximum Speed (rpm)	C _s Centrifugal loss (bar/rpm ²)	J (kg·m ²)	Mass (kg)	Friction Area (cm ²)	Friction Lining Thickness (mm)	Worn	AirTube Cavity (dm ³)	Minimum Drum Diameter (mm)
11.5VC500	142639	3,050	1800	1,59 E-06	1,81	43	1071	8	4	1,15	290
14VC500	143829	4,430	1500	1,93 E-06	3,28	58	1322	8	4	1,56	353
16VC600	142640	7,340	1400	2,00 E-06	4,83	68	1825	8	4	1,97	404
20VC600	142641	10,505	1200	2,76 E-06	8,11	81	2451	8	4	2,30	505
24VC650	142642	15,250	1050	3,38 E-06	15,50	111	3006	11	4	3,28	607
28VC650	142643	20,560	1000	4,00 E-06	22,55	127	3535	11	4	4,43	706
33VC650	142644	28,810	900	5,11 E-06	45,49	178	4147	14	7	5,90	833
37VC650	142645	36,155	800	6,21 E-06	58,80	196	4644	14	7	6,56	935
42VC650	142647	42,930	800	6,56 E-06	83,58	220	5302	14	7	7,22	1062

ENGL ISH

(Dimensions in inches)

Size	D ₂	D ₃	D ₂₄	D ₂₅	G	H ₂	H ₆	H ₇	L No.	L Dia.	O ₃	O ₄ No.	O ₄ Size	Q (Deg)	V	W No.	W Width
11.5VC500	6.13	0.23	2.38	0.38	19.625	18.875	11.63	18.88	16	0.375	0.31	2	3/8-18 NPT	11.25	0.56	8	5.00
14VC500	6.13	0.31	2.88	0.58	23.500	22.500	14.22	22.25	8	0.500	0.38	4	3/8-18 NPT	22.50	0.56	8	5.00
16VC600	7.38	0.31	2.88	0.59	25.500	24.375	16.22	24.38	12	0.500	0.38	4	3/8-18 NPT	15.00	0.69	8	6.00
20VC600	7.38	0.31	2.88	0.59	29.500	28.375	20.22	28.38	12	0.500	0.38	4	3/8-18 NPT	15.00	0.69	10	6.00
24VC650	7.69	0.39	2.88	0.63	34.000	32.750	24.22	32.50	16	0.625	0.50	4	1/2-14 NPT	11.25	0.59	12	6.50
28VC650	7.69	0.39	2.88	0.63	38.000	36.750	28.22	36.50	16	0.625	0.50	4	1/2-14 NPT	11.25	0.59	14	6.50
33VC650	7.69	0.47	3.13	0.63	44.625	43.125	33.22	43.25	18	0.750	0.63	4	3/4-14 NPT	15.00	0.59	16	6.50
37VC650	7.69	0.47	3.13	0.69	48.625	47.125	37.22	47.25	20	0.750	0.63	4	3/4-14 NPT	9.00	0.59	18	6.50
42VC650	7.69	0.47	3.13	0.66	53.625	52.125	42.22	52.25	24	0.750	0.63	4	3/4-14 NPT	7.50	0.59	20	6.50

SI

(Dimensions in millimeters)

Size	D ₂	D ₃	D ₂₄	D ₂₅	G	H ₂	H ₆	H ₇	L No.	L Dia.	O ₃	O ₄ No.	O ₄ Size	Q (Deg)	V	W No.	W Width
11.5VC500	156	6	60	10	498,5	479,4	295	479	16	9,5	8	2	3/8-18 NPT	11,25	14	8	127
15VC500	156	8	73	15	596,9	571,5	361	565	8	12,7	10	4	3/8-18 NPT	22,50	14	8	127
16VC600	187	8	73	15	647,7	619,1	412	619	12	12,7	10	4	3/8-18 NPT	15,00	17	8	152
20VC600	187	8	73	15	749,3	720,7	514	721	12	12,7	10	4	3/8-18 NPT	15,00	17	10	152
24VC650	195	10		73						16		863,6	1/2-14 NPT	11,25	15	12	165
28VC650	195	10		73						16		965,2	1/2-14 NPT	11,25	15	14	165
33VC650	195	12		73						16		1133,5	3/4-14 NPT	15,00	15	16	165
37VC650	195	12		73						17		1235,1	3/4-14 NPT	9,00	15	18	165
42VC650	195	12	79	19,1	1362,1	1324,0	1072	1327	24	19,1	16	4	3/4-14 NPT	7,50	15	20	165

Notes

Part Number refers to basic part number only. When ordering, the number of air inlets and type of connection must be specified.

M_r — Dynamic torque shown, static torque approximately 25% greater. Torque in each application is dependent upon air pressure and speed.

Tolerance for sizes (G) :

11.5 thru 20
+0.000/-0.005 in
(+0,00/-0,13 mm)

24 thru 28
+0.000/-0.008 in
(+0,00/-0,20 mm)

33 thru 42
+0.000/-0.010 in
(+0,00/-0,25 mm)

(L) Tolerance:

+0.005/-0.000 in
(+0,13/-0,00 mm)

(O₄) — Sizes 11.5 available with one or two inlets. All other sizes have four inlets.

(Maximum Speed) — Maximum rpm is dependent upon operating conditions and varies for each application. Consult factory for applications exceeding these speeds.

(Air Tube Cavity) — Drum contact with worn shoes.

Airflex® Dual Narrow VC Elements

Form VC-502 Sizes 11.5 to 42

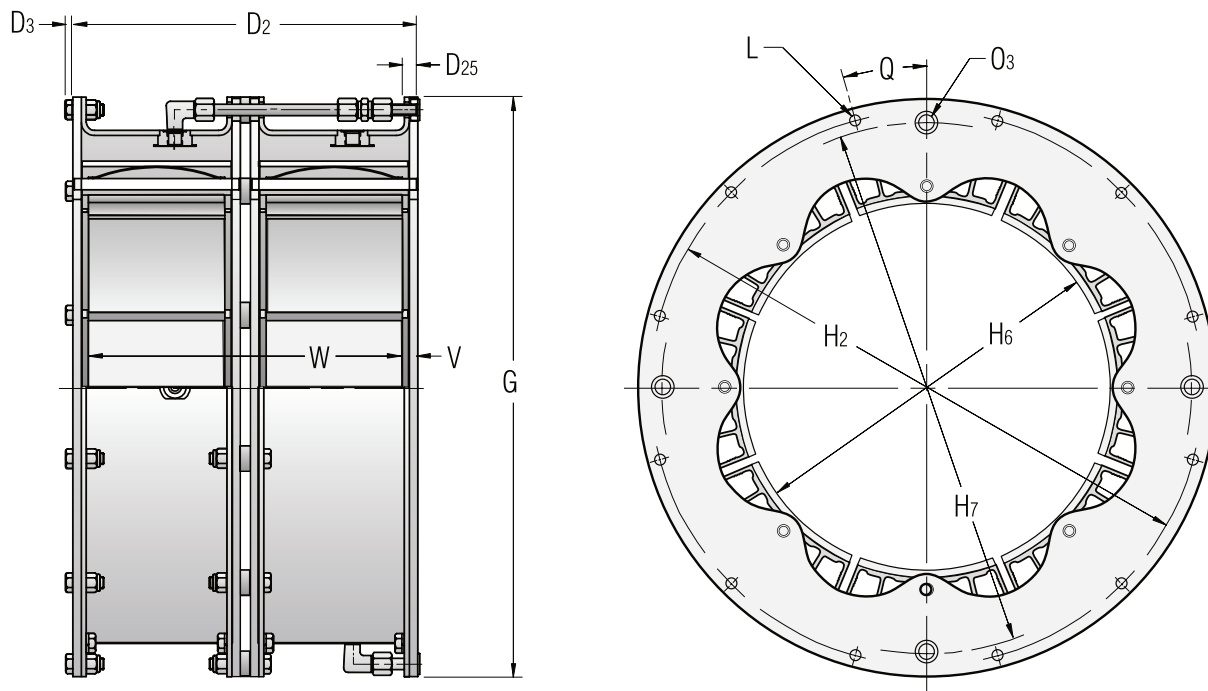

ENGLISH

Size	Part Number	M_r Torque Rating lb-in@ 75 psi	Max. Speed (rpm)	C_s Centrifugal Loss (psi/rpm ²)	Wk^2 (lb-ft ²)	Weight (lb)	Friction Area (in ²)	Friction New	Lining Thickness (ins) Worn	Air Tube Cavity (in ³)	Minimum Drum Diameter (ins)
11.5VC500	142112	5,4000	1800	23 E-06	86	197	332	0.32	0.16	140	11.41
14VC500	142114	78,400	1500	28 E-06	156	258	410	0.32	0.16	190	13.91
16VC600	142115	130,000	1400	29 E-06	230	307	566	0.32	0.16	240	15.91
20VC600	142116	186,000	1200	40 E-06	386	363	760	0.32	0.16	280	19.88
24VC650	142117	270,000	1050	49 E-06	738	497	932	0.44	0.16	400	23.88
28VC650	142118	364,000	1000	58 E-06	1074	565	1096	0.44	0.16	540	27.81
33VC650	142119	510,000	900	74 E-06	2166	784	1286	0.57	0.28	720	32.81
37VC650	142120	640,000	800	90 E-06	2800	871	1440	0.57	0.28	800	36.81
42VC650	142121	760,000	800	95 E-06	3980	980	1644	0.57	0.28	880	41.81

Size	Part Number	M_r Torque Rating N-m@ 5,2 bar	Max. Speed (rpm)	C_s Centrifugal Loss (bar/rpm ²)	J (kg-m ²)	Mass (kg)	Friction Area (cm ²)	Friction New	Lining Thickness (mm) Worn	Air Tube Cavity (dm ³)	Minimum Drum Diameter (mm)
11.5VC500	142112	6,100	1800	1,59 E-06	3,61	89	2141	8	4	2,30	290
14VC500	142114	8,860	1500	1,93 E-06	6,55	117	2645	8	4	3,12	353
16VC600	142115	14,690	1400	2,00 E-06	9,66	139	3651	8	4	3,94	404
20VC600	142116	21,010	1200	2,76 E-06	16,21	164	4902	8	4	4,59	505
24VC650	142117	30,500	1050	3,38 E-06	31,00	225	6011	11	4	6,56	607
28VC650	142118	41,125	1000	4,00 E-06	45,11	256	7069	11	4	8,86	706
33VC650	142119	57,620	900	5,11 E-06	90,97	355	8295	14	7	11,8	833
37VC650	142120	72,310	800	6,21 E-06	117,6	395	9288	14	7	13,1	935
42VC650	142121	85,870	800	6,56 E-06	167,2	444	10604	14	7	14,4	1062

E NGL ISH

Size	(Dimensions in inches)							L No.	L Dia	O ₃ No.	O ₃ Size	Q (Deg)	V	W No.	W Width
	D ₂	D ₃	D ₂₅	G	H ₂	H ₆	H ₇								
11.5VC500	12.75	0.23	0.56	19.625	18.875	11.63	18.88	16	0.375	2	0.31	11.25	0.56	16	11.63
14VC500	12.69	0.31	0.56	23.500	22.500	14.22	22.25	8	0.500	4	0.38	22.50	0.56	16	11.57
16VC600	15.19	0.31	0.56	25.500	24.375	16.22	24.38	12	0.500	4	0.38	15.00	0.69	16	13.81
20VC600	15.19	0.31	0.56	29.500	28.375	20.22	28.38	12	0.500	4	0.38	15.00	0.69	20	13.81
24VC650	15.94	0.39	0.63	34.000	32.750	24.22	32.50	16	0.625	4	0.50	11.25	0.59	24	14.75
28VC650	15.94	0.39	0.63	38.000	36.750	28.22	36.50	16	0.625	4	0.50	11.25	0.59	28	14.75
33VC650	15.94	0.47	0.69	44.625	43.125	33.22	43.25	18	0.750	4	0.63	15.00	0.59	32	14.75
37VC650	15.94	0.47	0.69	48.625	47.125	37.22	47.25	20	0.750	4	0.63	9.00	0.59	36	14.75
42VC650	15.94	0.47	0.69	53.625	52.125	42.22	52.25	24	0.750	4	0.63	7.50	0.59	40	14.75

SI

Size	(Dimensions in millimeters)							L No.	L Dia	O ₃ No.	O ₃ Size	Q (Deg)	V	W No.	W Width
	D ₂	D ₃	D ₂₅	G	H ₂	H ₆	H ₇								
11.5VC500	324	6	14	498,5	479,4	295	479	16	9,5	2	8	11,25	14	16	295
14VC500	322	8	14	596,9	571,5	361	565	8	12,7	4	10	22,50	14	16	294
16VC600	386	8	14	647,7	619,1	412	619	12	12,7	4	10	15,00	17	16	351
20VC600	386	8	14	749,3	720,7	514	721	12	12,7	4	10	15,00	17	20	351
24VC650	405	10	16	863,6	831,9	615	826	16	15,9	4	13	11,25	15	24	375
28VC650	405	10	16	965,2	933,5	717	927	16	15,9	4	13	11,25	15	28	375
33VC650	405	12	18	1133,5	1095,4	844	1099	18	19,1	4	16	15,00	15	32	375
37VC650	405	12	18	1235,1	1197,0	945	1200	20	19,1	4	16	9,00	15	36	375
42VC650	405	12	18	1362,1	1324,0	1072	1327	24	19,1	4	16	7,50	15	40	375

Notes:

Part Number refers to basic part number only. When ordering, the number of air inlets and type of connection must be specified.

M_r — Dynamic torque shown, static torque approximately 25% greater. Torque in each application is dependent upon air pressure and speed.

Tolerance for sizes (G) :

11.5 thru 20
+0.000/-0.005 in
(+0,00/-0,13 mm)

24 thru 28
+0.000/-0.008 in
(+0,00/-0,20 mm)

33 thru 42
+0.000/-0.010 in
(+0,00/-0,25 mm)

(L) Tolerance :
+0.005/-0.000 in
(+0,13/-0,00 mm)

(O₄) — Sizes 11.5 available with one or two inlets. All other sizes have four inlets.

(Maximum Speed) — Maximum rpm is dependent upon operating conditions and varies for each application. Consult factory for applications exceeding these speeds.

(Air Tube Cavity) — Drum contact with worn shoes.

Airflex® Single Wide VC Elements

Form VC-503 Sizes 14 to 76

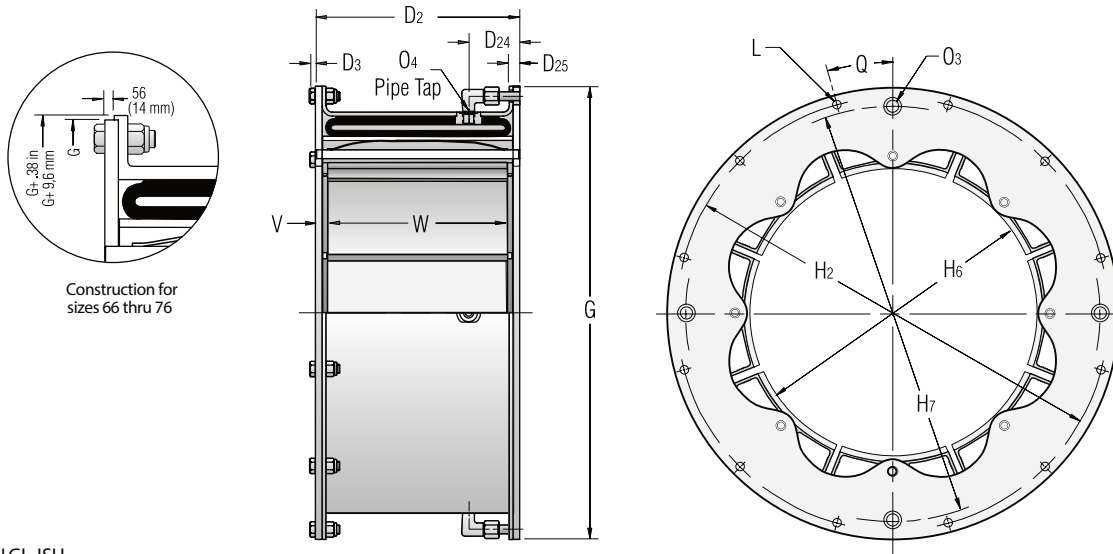

ENGLISH

Size	Part Number	M _r Torque Rating lb-in@ 75 psi	Max. Speed (rpm)	C _s Centrifugal L oss (psi/rpm ²)	Wk ² (lb-ft ²)	Weight (lb)	Friction Area (in ²)	Friction New	L ining Thickness (ins) Worn	Air Tube Cavity (in ³)	Minimum Drum Diameter (ins)
14VC1000	142838	85,000	1800	22 E-06	127	213	350	0.32	0.16	185	13.91
16VC1000	142821	114,000	1400	27 E-06	212	240	470	0.32	0.16	255	15.91
20VC1000	142832	161,000	1300	37 E-06	309	282	635	0.32	0.16	310	19.87
24VC1000	142675	219,000	1250	46 E-06	552	378	720	0.44	0.16	465	23.87
28VC1000	142674	296,000	1100	55 E-06	826	431	840	0.44	0.16	530	27.81
32VC1000	142673	415,000	1050	63 E-06	1570	624	960	0.57	0.38	600	31.81
38VC1200	142739	680,000	740	82 E-06	2330	684	1360	0.57	0.38	755	37.81
42VC1200	142677	819,000	670	86 E-06	3670	895	1500	0.57	0.38	850	41.75
46VC1200	142671	950,000	600	108 E-06	4830	980	1410	0.68	0.38	1205	45.75
52VC1200	142841	1,215,000	550	127 E-06	7285	1310	1590	0.68	0.38	1510	51.75
51VC1600	142835	1,610,000	550	125 E-06	10580	1830	2380	0.66	0.30	2000	50.75
60VC1600	142915	2,183,000	520	145 E-06	20532	2374	2800	0.66	0.30	2350	59.75
66VC1600	142097	2,800,000	480	185 E-06	24850	2630	3080	0.66	0.30	1950	65.75
76VC1600	—	—	—	Consult Factory	—	—	—	—	—	—	—

Size	Part Number	M _r Torque Rating N-m@ 5.2 bar	Max. Speed (rpm)	C _s Centrifugal L oss (bar/rpm ²)	J (kg-m ²)	Mass (kg)	Friction Area (cm ²)	Friction New	L ining Thickness (mm) Worn	Air Tube Cavity (dim ³)	Minimum Drum Diameter (mm)
14VC1000	142838	9,605	1800	1,52 E-06	5,33	96	2258	8	4	3,03	353
16VC1000	142821	12,880	1400	1,86 E-06	8,90	109	3032	8	4	4,18	404
20VC1000	142832	18,190	1300	2,55 E-06	12,98	128	4096	8	4	5,08	505
24VC1000	142675	24,745	1250	3,17 E-06	23,18	171	4644	11	4	7,63	606
28VC1000	142674	33,445	1100	3,80 E-06	34,69	195	5418	11	4	8,69	706
32VC1000	142673	46,890	1050	4,35 E-06	65,94	283	6192	14	10	9,84	808
38VC1200	142739	76,830	740	5,66 E-06	97,86	310	8772	14	10	12,4	960
42VC1200	142677	92,535	670	5,93 E-06	154,1	405	9675	14	10	13,9	1060
46VC1200	142671	107,335	600	7,45 E-06	202,9	444	9097	17	10	19,8	1162
52VC1200	142841	137,275	550	8,76 E-06	306,0	594	10256	17	10	24,8	1314
51VC1600	142835	181,905	550	8,63 E-06	444,4	830	15351	17	8	32,8	1289
60VC1600	142915	246,645	520	10,01 E-06	852,3	1077	18060	17	8	38,5	1518
66VC1600	142097	316,355	480	12,83 E-06	1044	1191	19866	17	8	32,1	1670
76VC1600	—	—	—	Consult Factory	—	—	—	—	—	—	—

E NGL ISH

Size	(Dimensions in inches)				G	H ₂	H ₆	H ₇	L No.	L Dia.	O ₃	O ₄ No.	O ₄ Size	Q (Deg)	V	W No.	W Width
	D ₂	D ₃	D ₂₄	D ₂₅													
14VC1000	11.56	0.31	2.88	0.63	23.500	22.500	14.22	22.25	8	0.500	0.38	4	3/8-18 NPT	22.50	0.78	8	10
16VC1000	11.56	0.31	2.88	0.63	25.500	24.375	16.22	24.38	12	0.500	0.38	4	3/8-18 NPT	15.00	0.78	8	10
20VC1000	11.56	0.31	2.88	0.63	29.500	28.375	20.22	28.38	12	0.500	0.38	4	3/8-18 NPT	15.00	0.78	8	10
24VC1000	11.56	0.39	2.88	0.63	34.000	32.750	24.22	32.50	16	0.625	0.50	4	1/2-14 NPT	11.25	0.78	10	10
28VC1000	11.56	0.39	2.88	0.63	38.000	36.750	28.22	36.50	16	0.625	0.50	4	1/2-14 NPT	11.25	0.78	10	10
32VC1000	11.63	0.39	2.88	0.63	43.875	42.625	32.22	42.13	24	0.625	0.50	4	1/2-14 NPT	7.50	0.81	12	10
38VC1200	13.75	0.47	3.13	0.69	49.375	47.875	38.22	48.00	20	0.750	0.63	4	3/4-14 NPT	9.00	0.88	12	12
42VC1200	13.75	0.47	3.13	0.66	53.625	52.125	42.22	52.25	24	0.750	0.63	4	3/4-14 NPT	7.50	0.88	14	12
46VC1200	13.75	0.55	4.88	0.78	60.250	58.500	46.25	57.50	24	0.875	0.63	4	3/4-14 NPT	7.50	0.88	16	12
52VC1200	14.25	0.55	7.13	1.13	67.000	65.500	52.25	65.00	32	0.875	0.88	4	1-11 1/2 NPT	5.63	1.13	18	12
51VC1600	18.25	0.55	9.13	1.13	67.000	65.500	51.25	65.00	32	0.875	0.88	4	1-11 1/2 NPT	5.63	1.13	18	16
60VC1600	18.50	0.61	9.25	1.38	77.000	75.000	60.43	74.25	36	1.000	0.88	4	1-11 1/2 NPT	5.00	1.25	20	16
66VC1600	18.50	0.78	9.25	1.38	82.123	79.625	66.22	78.38	40	1.312	0.88	4	1-11 1/2 NPT	5.00	1.25	22	16

SI

Size	(Dimensions in millimeters)				G	H ₂	H ₆	H ₇	L No.	L Dia.	O ₃	O ₄ No.	O ₄ Size	Q (Deg)	V	W No.	W Width
	D ₂	D ₃	D ₂₄	D ₂₅													
14VC1000	294	8	73	16	596,9	571,5	361	565	8	12,7	10	4	3/8-18 NPT	22,50	20	8	254
16VC1000	294	8	73	16	647,7	619,1	412	619	12	12,7	10	4	3/8-18 NPT	15,00	20	8	254
20VC1000	294	8	73	16	749,3	720,7	514	721	12	12,7	10	4	3/8-18 NPT	15,00	20	8	254
24VC1000	294	10	73	16	863,6	831,9	615	826	16	15,9	13	4	1/2-14 NPT	11,25	20	10	254
28VC1000	294	10	73	16	965,2	933,5	717	927	16	15,9	13	4	1/2-14 NPT	11,25	20	10	254
32VC1000	295	10	73	16	1114,4	1082,7	818	1070	24	15,9	13	4	1/2-14 NPT	7,50	21	12	254
38VC1200	349	12	79	18	1254,1	1216,0	971	1219	20	19,1	16	4	3/4-14 NPT	9,00	22	12	305
42VC1200	349	12	79	17	1362,1	1324,0	1072	1327	24	19,1	16	4	3/4-14 NPT	7,50	22	14	305
46VC1200	349	14	124	20	1530,4	1485,9	1175	1461	24	22,2	16	4	3/4-14 NPT	7,50	22	16	305
52VC1200	362	14	181	29	1701,8	1663,7	1327	1651	32	22,2	22	4	1-11 1/2 NPT	5,63	29	18	305
51VC1600	464	14	232	29	1701,8	1663,7	1302	1651	32	22,2	22	4	1-11 1/2 NPT	5,63	29	18	406
60VC1600	470	15	235	35	1955,8	1905,0	1535	1886	36	25,4	22	4	1-11 1/2 NPT	5,00	32	20	406
66VC1600	470	20	235	35	2085,9	2022,5	1682	1991	40	33,3	22	4	1-11 1/2 NPT	5,00	32	22	406

Notes:

Part Number refers to basic part number only. When ordering, the number of air inlets and type of connection must be specified.

M_r — Dynamic torque shown, static torque approximately 25% greater. Torque in each application is dependent upon air pressure and speed.

Tolerance for sizes (G) :

14 thru 20
+0.000/-0.005 in
(+0,00/-0,13 mm)

24 thru 28
+0.000/-0.008 in
(+0,00/-0,20 mm)

32 thru 60
+0.000/-0.010 in
(+0,00/-0,25 mm)

66 thru 76
+0.000/-0.005 in
(+0,00/-0,13 mm)

(L) Tolerance :
+0.005/-0.000 in
(+0,13/-0,00 mm)

(Maximum Speed) —
Maximum rpm is dependent upon operating conditions and varies for each application. Consult factory for applications exceeding these speeds.

(Air Tube Cavity) — Drum contact with worn shoes.

Airflex® Dual Wide VC Elements

Form VC-504 Sizes 16 to 76

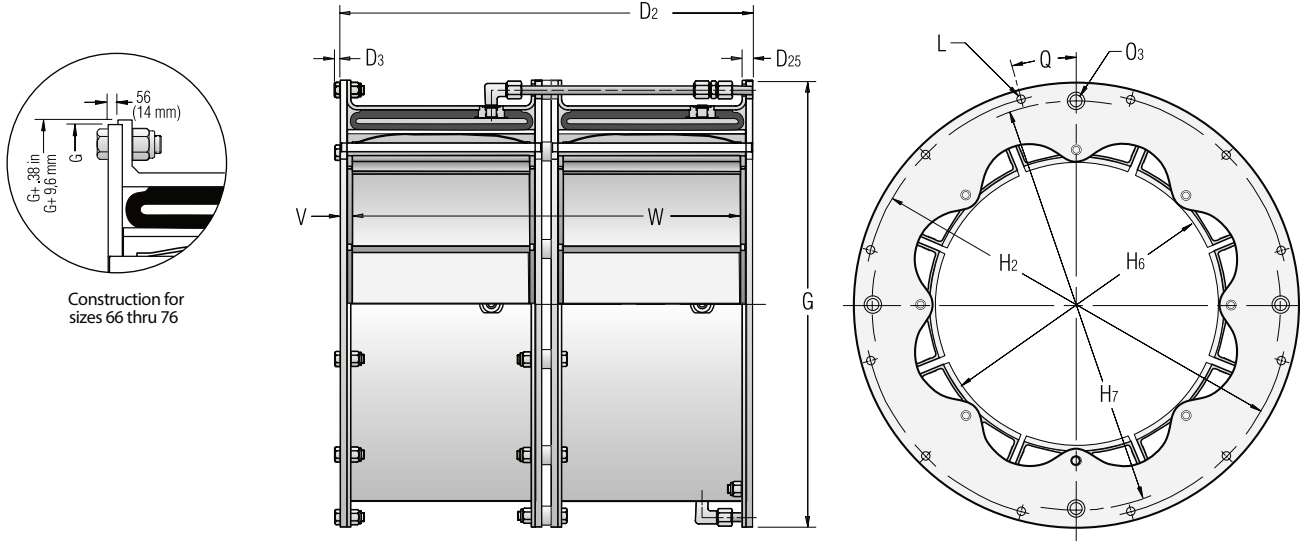

Construction for sizes 66 thru 76

ENGLISH

Size	Part Number	M_f Torque Rating lb-in@ 75 psi	Max. Speed (rpm)	C_s Centrifugal Loss (psi/rpm ²)	Wk^2 (lb-ft ²)	Weight (lb)	Friction Area (in ²)	Friction New	Lining Thickness (ins) Worn	Air Tube Cavity (in ³)	Minimum Drum Diameter (ins)
16VC1000	142122	228,000	1400	27 E-06	380	430	940	0.32	0.16	510	15.91
20VC1000	142123	322,000	1300	37 E-06	618	568	1270	0.32	0.16	620	19.87
24VC1000	142124	438,000	1250	46 E-06	1104	756	1440	0.44	0.16	930	23.87
28VC1000	142125	592,000	1100	55 E-06	1652	862	1680	0.44	0.16	1060	27.81
32VC1000	142126	830,000	1050	63 E-06	3140	1248	1920	0.57	0.38	1200	31.81
38VC1200	142127	1,360,000	740	82 E-06	4660	1368	2720	0.57	0.38	1510	37.81
42VC1200	142128	1,638,000	670	86 E-06	7340	1790	3000	0.57	0.38	1700	41.75
46VC1200	142129	1,900,000	600	108 E-06	9660	1960	3180	0.68	0.38	2410	45.75
52VC1200	142131	2,430,000	550	127 E-06	14570	2384	3580	0.68	0.38	3020	51.75
51VC1600	142130	3,220,000	550	125 E-06	21160	3868	4760	0.66	0.30	4000	50.75
60VC1600	142132	4,366,000	520	145 E-06	41064	4900	5600	0.66	0.30	4700	59.75
66VC1600	142198	5,600,000	480	186 E-06	49700	5260	6160	0.66	0.30	3920	65.75
76VC1600	146509	7,300,000	416	241 E-06	72940	5970	6940	0.66	0.30	4800	75.75
76VC2000	146531	9,300,000	275	146 E-06	82084	6700	8390	0.66	0.30	4963	75.75

Size	Part Number	M_f Torque Rating N-m@ 5,2 bar	Max. Speed (rpm)	C_s Centrifugal Loss (bar/rpm ²)	J (kg-m ²)	Mass (kg)	Friction Area (cm ²)	Friction New	Lining Thickness (mm) Worn	Air Tube Cavity (dm ³)	Minimum Drum Diameter (mm)
16VC1000	142122	25,760	1400	1,86 E-06	15,96	195	6063	8	4	8,36	404
20VC1000	142123	36,380	1300	2,55 E-06	25,96	257	8192	8	4	10,2	505
24VC1000	142124	49,490	1250	3,17 E-06	46,37	342	9288	11	4	15,3	606
24VC1000	142125	66,890	1100	3,80 E-06	69,38	390	10836	11	4	17,4	706
32VC1000	142126	93,780	1050	4,35 E-06	131,9	565	12384	14	10	19,7	808
38VC1200	142127	153,660	740	5,66 E-06	195,7	620	17544	14	10	24,8	960
42VC1200	142128	185,070	670	5,93 E-06	308,3	811	19350	14	10	27,9	1060
46VC1200	142129	214,670	600	7,45 E-06	405,7	888	20516	17	10	39,5	1162
52VC1200	142131	274,550	550	8,76 E-06	611,9	1080	23097	17	10	49,5	1314
51VC1600	142130	363,810	550	8,63 E-06	888,7	1752	30702	17	8	65,6	1289
60VC1600	142132	493,290	520	10,01 E-06	1725	2220	36120	17	8	77,1	1518
66VC1600	142198	632,710	480	12,83 E-06	2087	2383	39732	17	8	64,3	1670
76VC1600	146509	827,050	416	16,66 E-06	3074	2705	45150	17	8	79,0	1924
76VC2000	146531	1,050,760	275	10,06 E-06	3461	3038	54128	17	8	81,7	1924

E NGL ISH

Size	(Dimensions in inches)				H ₂	H ₆	H ₇	L No.	L Dia	O ₃ No.	O ₃ Size	Q (Deg)	V	W No.	W Width
	D ₂	D ₃	D ₂₅	G											
16VC1000	23.69	0.31	0.63	25.500	24.375	16.22	24.38	12	0.500	4	0.38	15.00	0.78	16	22.13
20VC1000	23.69	0.31	0.63	29.500	28.375	20.22	28.38	12	0.500	4	0.38	15.00	0.78	16	22.13
24VC1000	23.69	0.39	0.63	34.000	32.750	24.22	32.50	16	0.625	4	0.50	11.25	0.78	20	22.13
28VC1000	23.69	0.39	0.63	38.000	36.750	28.22	36.50	16	0.625	4	0.50	11.25	0.78	20	22.13
32VC1000	23.81	0.39	0.63	43.875	42.625	32.22	42.13	24	0.625	4	0.50	7.50	0.81	24	23.19
38VC1200	28.06	0.47	0.66	49.375	47.875	38.22	48.00	20	0.750	4	0.63	9.00	0.88	24	26.31
42VC1200	28.06	0.47	0.66	53.625	52.125	42.22	52.25	24	0.750	4	0.63	7.50	0.88	28	26.31
46VC1200	28.06	0.55	0.75	60.250	58.500	46.25	57.50	24	0.875	4	0.63	7.50	0.88	32	26.31
52VC1200	29.06	0.55	1.13	67.000	65.500	52.25	65.00	32	0.875	4	0.88	5.63	1.13	36	26.81
51VC1600	37.06	0.55	1.13	67.000	65.500	51.25	65.00	32	0.875	4	0.88	5.63	1.13	36	34.81
60VC1600	37.56	0.61	1.38	77.000	75.000	60.43	74.25	36	1.000	4	0.88	5.00	1.25	40	35.06
66VC1600	37.00	0.78	1.38	82.123	79.625	66.22	78.38	40	1.312	4	0.88	4.50	1.25	44	34.50
76VC1600	37.00	0.88	1.38	92.123	89.625	76.72	88.38	48	1.312	4	0.88	3.75	1.25	50	34.50
76VC2000	45.00	0.88	1.38	92.123	89.625	76.72	88.38	48	1.312	4	0.88	3.75	1.25	50	42.56

SI

Size	(Dimensions in millimeters)				H ₂	H ₆	H ₇	L No.	L Dia	O ₃ No.	O ₃ Size	Q (Deg)	V	W No.	W Width
	D ₂	D ₃	D ₂₅	G											
16VC1000	602	8	16	647,7	619,1	412	619	12	12,7	4	10	15,00	20	16	562
20VC1000	602	8	16	749,3	720,7	514	721	12	12,7	4	10	15,00	20	16	562
24VC1000	602	10	16	863,6	831,9	615	826	16	15,9	4	13	11,25	20	20	562
28VC1000	602	10	16	965,2	933,5	717	927	16	15,9	4	13	11,25	20	20	562
32VC1000	605	10	16	1114,4	1082,7	818	1070	24	15,9	4	13	7,50	21	24	589
38VC1200	713	12	17	1254,1	1216,0	971	1219	20	19,1	4	16	9,00	22	24	668
42VC1200	713	12	17	1362,1	1324,0	1072	1327	24	19,1	4	16	7,50	22	28	668
42VC1200	713	14	19	1530,4	1485,9	1175	1461	24	22,2	4	16	7,50	22	32	668
52VC1200	738	14	29	1701,8	1663,7	1327	1651	32	22,2	4	22	5,63	29	36	681
51VC1600	941	14	29	1701,8	1663,7	1302	1651	32	22,2	4	22	5,63	29	36	884
60VC1600	954	15	35	1955,8	1905,0	1535	1886	36	25,4	4	22	5,00	32	40	891
66VC1600	940	20	35	2085,9	2022,5	1682	1991	40	33,3	4	22	4,50	32	44	876
76VC1600	940	22	35	2339,9	2276,5	1948	2245	48	33,3	4	22	3,75	32	50	876
76VC2000	1143	22	35	2339,9	2276,5	1948	2245	48	33,3	4	22	3,75	32	50	1081

Notes:

Part Number refers to basic part number only. When ordering, the number of air inlets and type of connection must be specified.

M_r — Dynamic torque shown, static torque approximately 25% greater. Torque in each application is dependent upon air pressure and speed.

Tolerance for sizes (G):

16 thru 20
+0.000/-0.005 in
(+0,00/-0,13 mm)

24 thru 28
+0.000/-0.008 in
(+0,00/-0,20 mm)

32 thru 60
+0.000/-0.010 in
(+0,00/-0,25 mm)

66 thru 76
+0.000/-0.005 in
(+0,00/-0,13 mm)

(L) Tolerance :
+0.005/-0.000 in
(+0,13/-0,00 mm)

(O₃) — All sizes available with either two or four outlets.

(Maximum Speed) — Maximum rpm is dependent upon operating conditions and varies for each application. Consult factory for applications exceeding these speeds.

(Air Tube Cavity) — Drum contact with worn shoes.

Airflex® VC Mounting Components

Form VC-521 Spiders — Single Narrow Sizes

— Dimensional and Technical Data

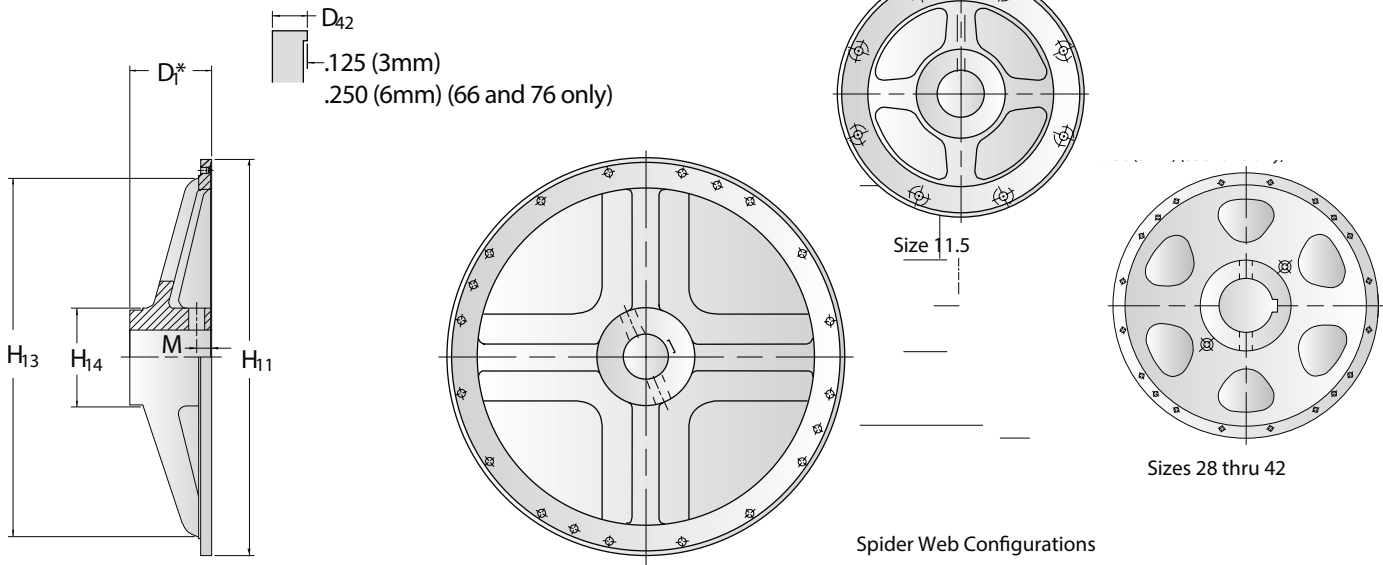

*D₁ is measured between the machined surfaces of the hub and spidered rim.
Spider shown is for sizes 14 thru 24

Sizes 14 thru 24

Spider Web Configurations

ENGLISH

Size	Part Number	Weight (lb)	Wk ² (lb-ft ²)	D ₁	(Dimensions in inches)			
					D ₄₂	H ₁₁	H ₁₃	H ₁₄
11.5VC500	408376	70	19	4.34	0.59	20.00	N/A	6.00
14VC500	411170	102	35	5.50	1.06	24.00	21.25	8.00
16VC600	408277	139	50	5.50	1.06	26.00	23.25	8.00
20VC600	408279	224	122	6.00	1.06	30.00	27.00	8.50
24VC650	408281	260	174	6.50	1.06	34.63	31.00	9.00
28VC650	505480	514	534	8.00	1.13	38.63	35.25	11.50
33VC650	505285	716	811	9.00	1.13	45.25	41.00	13.50
37VC650	505275	940	1404	10.00	1.25	49.25	45.50	13.50
42VC650	502369	1284	2106	11.00	1.31	54.25	50.48	16.50

SI

Size	Part Number	Mass (kg)	J (kg-m ²)	D ₁	(Dimensions in millimeters)			
					D ₄₂	H ₁₁	H ₁₃	H ₁₄
11.5VC500	408376	32	0,80	110	15	508	N/A	152
14VC500	411170	46	1,47	140	27	610	540	203
16VC600	408277	63	2,10	140	27	660	591	203
20VC600	408279	101	5,12	152	27	762	686	216
24VC650	408281	118	7,31	165	27	880	787	229
28VC650	505480	233	22,43	203	29	981	895	292
33VC650	505285	324	34,06	229	29	1149	1041	343
37VC650	505275	426	58,97	254	32	1251	1156	343
42VC650	502369	582	88,45	279	33	1378	1282	419

Notes:

Refer to VC Spider Piping and Configuration catalog page for other sizes.

For size 11.5, part number for two air passages.
Part number for single air passage - 408375.

Table data based upon minimum bore.

Airflex[®] VC Mounting Components

Form VC-522 Spiders — Dual Narrow Sizes

— Dimensional and Technical Data

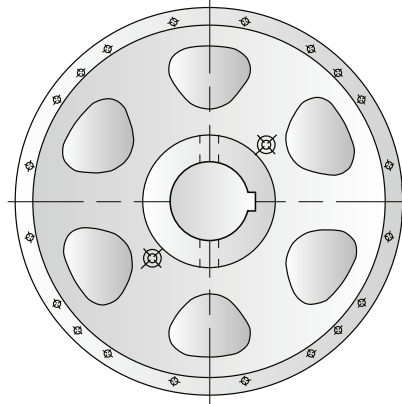
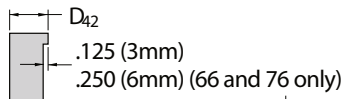
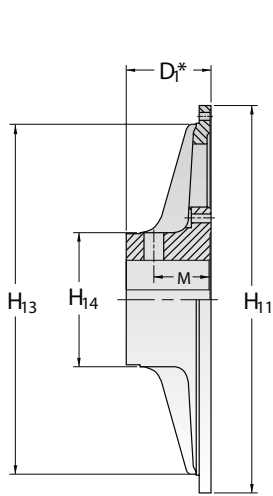

Sizes 16 thru 42

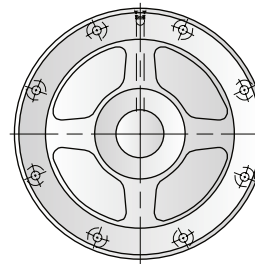

Size 11.5

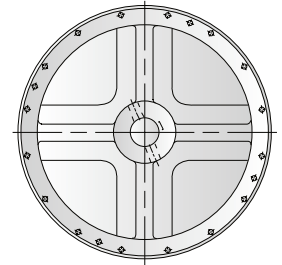

Size 14

Spider Web Configurations

*D₁ is measured between the machined surfaces of the hub and spidered rim.
Spider shown is for sizes 20 thru 24

ENGLISH

Size	Part Number	Weight (lb)	Wk ² (lb-ft ²)	(Dimensions in inches)				
				D ₁	D ₄₂	H ₁₁	H ₁₃	H ₁₄
11.5VC500	410856	71	19	4.84	0.62	20.00	N/A	7.50
14VC500	411170	102	35	5.50	1.06	24.00	21.25	8.00
16VC600	505283	236	111	5.50	1.50	26.00	23.00	10.00
20VC600	509698	295	167	7.00	1.13	30.00	27.00	10.00
24VC850	509699	408	285	7.75	1.13	34.63	31.50	12.00
28VC650	509700	554	474	8.00	1.13	38.63	35.25	14.00
33VC650	509701	802	965	9.00	1.13	45.25	41.00	15.00
37VC650	509702	981	1356	10.00	1.25	49.25	45.50	15.50
42VC650	509703	1116	1868	11.00	1.31	54.25	50.50	16.50

SI

Size	Part Number	Mass (kg)	J (kg-m ²)	(Dimensions in millimeters)				
				D ₁	D ₄₂	H ₁₁	H ₁₃	H ₁₄
11,5VC500	410856	32	0,80	122,9	15,8	508,0	N/A	190,5
14VC500	411170	46	1,47	139,7	26,9	609,6	539,7	203,2
16VC600	505283	107	4,66	139,7	38,1	660,4	584,2	254,0
20VC600	509698	134	7,01	177,8	28,7	762,0	685,8	254,0
24VC650	509699	185	11,97	196,9	28,7	879,6	800,1	304,9
28VC650	509700	251	19,91	203,2	28,7	981,2	895,3	355,6
33VC650	509701	363	40,53	228,6	28,7	1149,4	1041,0	381,0
37VC650	509702	444	56,95	254,0	31,8	1251,0	1155,0	388,7
42VC650	509703	506	78,46	279,4	33,3	1378,0	1282,0	419,1

Notes:

1 Refer to VC Spider Piping and Configuration catalog page for other sizes.

Table data based upon minimum bore.

Airflex® VC Mounting Components

Form VC-523 Spiders — Single Wide Sizes —

Dimensional and Technical Data

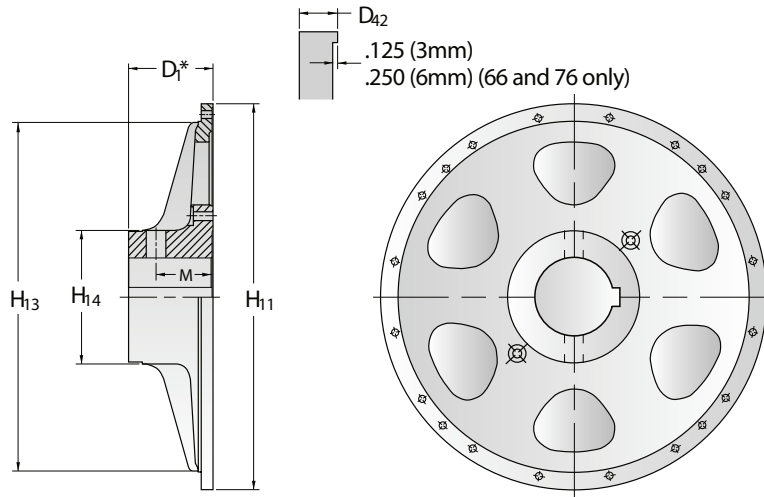

*D₁ is measured between the machined surfaces of the hub and spidered rim.

Spider shown is for sizes 20 thru 24

ENGLISH

Size	Part Number	Weight (lb)	Wk ² (lb-ft ²)	D ₁	(Dimensions in inches)			
					D ₄₂	H ₁₁	H ₁₃	H ₁₄
14VC1000	508545	205	79	5.50	1.13	24.00	21.00	8.00
16VC1000	505283	236	111	5.50	1.50	26.00	23.00	10.00
20VC1000	509698	295	167	7.00	1.13	30.00	27.00	10.00
24VC1000	509699	408	285	7.75	1.13	34.63	31.50	12.00
28VC1000	509700	554	474	8.00	1.13	38.63	35.25	14.00
32VC1000	509706	727	781	9.00	1.13	44.50	41.00	15.00
38VC1200	509707	1002	1502	10.00	1.25	50.00	45.50	15.50
42VC1200	509703	1116	1868	11.00	1.31	54.25	50.50	16.50
46VC1200	509708	1504	2968	11.00	1.50	61.00	56.50	17.00
52VC1200	509709	2579	5087	12.50	1.69	67.75	63.25	23.00
51VC1600	509710	2621	6706	15.00	1.69	67.75	63.25	20.00
60VC1600	509711	4096	13346	16.00	1.88	77.75	72.00	26.00

SI

Size	Part Number	Mass (kg)	J (kg-m ²)	D ₁	(Dimensions in millimeters)			
					D ₄₂	H ₁₁	H ₁₃	H ₁₄
14VC1000	508545	93	3,32	140	29	610	533	203
16VC1000	505283	107	4,66	140	38	660	584	254
20VC1000	509698	134	7,01	178	29	762	686	254
24VC1000	509699	185	11,97	197	29	880	800	305
28VC1000	509700	251	19,91	203	29	981	895	356
32VC1000	509706	329	32,80	229	29	1130	1041	381
38VC1200	509707	454	63,08	254	32	1270	1156	394
42VC1200	509703	506	78,46	279	33	1378	1283	419
46VC1200	509708	681	124,7	279	38	1549	1435	432
52VC1200	509709	1168	213,7	318	43	1721	1607	584
51VC1600	509710	1187	281,7	381	43	1721	1607	508
60VC1600	509711	1855	560,5	406	48	1975	1829	660

Notes:

1 Refer to VC Spider Piping and Configuration catalog page for other sizes.

Table data based upon minimum bore.

Airflex® VC Mounting Components

Form VC-524 Spiders — Dual Wide Sizes —

Dimensional and Technical Data

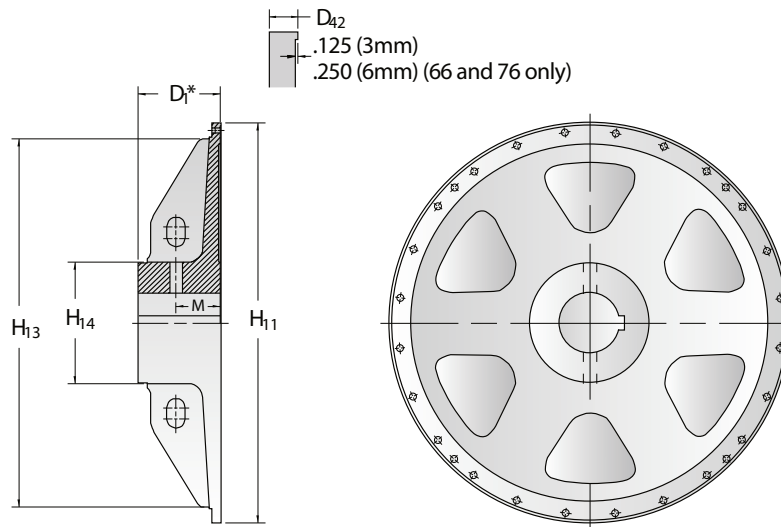

Web Configuration shown is for all sizes

*D₁ is measured between the machined surfaces of the hub and spidered rim.

Spider shown is for sizes 20 thru 24

ENGL ISH

Size	Part Number	Weight (lb)	Wk ² (lb-ft ²)	(Dimensions in inches)				
				D ₁	D ₄₂	H ₁₁	H ₁₃	H ₁₄
16VC1000	505284	264	113	8.00	1.50	26.00	23.00	10.00
20VC1000	509693	333	197	9.50	1.13	30.00	27.00	11.00
24VC1000	509694	442	312	9.31	1.13	34.63	31.50	12.50
28VC1000	509695	680	597	10.00	1.13	38.63	35.25	14.00
32VC1000	509696	967	932	12.00	1.13	44.50	41.00	16.75
38VC1200	509646	1350	1625	13.00	1.25	50.00	45.50	18.50
42VC1200	509647	1763	2445	17.00	1.31	54.25	50.50	19.00
46VC1200	509691	1855	3577	17.00	1.44	61.00	56.50	20.00
52VC1200	509648	2854	5277	17.00	1.69	67.75	63.25	23.00
51VC1600	509649	3639	7611	20.00	1.69	67.75	63.25	25.00
60VC1600	509692	5402	14489	24.00	1.88	77.75	72.00	30.00
66VC1600	514261	7385	Consult Factory	25.63	1.88	82.50	76.00	34.50
76VC1600	515152	9245	32860	27.00	1.88	93.00	86.00	38.50
76VC2000	515152	9245	32860	27.00	1.88	93.00	86.00	38.50

SI

Size	Part Number	Mass (kg)	J (kg-m ²)	(Dimensions in millimeters)				
				D ₁	D ₄₂	H ₁₁	H ₁₃	H ₁₄
16VC1000	505284	120	4,75	203	38	660	594	254
20VC1000	509693	151	8,27	241	29	762	686	279
24VC1000	509694	200	13,10	236	29	880	800	318
28VC1000	509695	306	25,07	254	29	981	895	356
32VC1000	509696	438	39,14	305	29	1130	1041	425
38VC1200	509646	612	68,25	330	32	1270	1156	470
42VC1200	509647	799	102,7	432	33	1378	1283	483
46VC1200	509691	840	150,2	432	37	1549	1435	508
52VC1200	509648	1293	221,6	432	43	1721	1607	584
51VC1600	509649	1648	319,7	508	43	1721	1607	635
60VC1600	509692	2447	608,5	610	48	1975	1829	762
66VC1600	514261	3349	CF	651	48	2096	1930	876
76VC1600	515152	4194	1380	686	48	2362	2184	978
76VC2000	515152	4194	1380	686	48	2362	2184	978

Notes:

Refer to VC Spider Piping and Configuration catalog page for other sizes.

Table data based upon minimum bore.

Airflex® VC Mounting Components

Form VC-528 — Internal Flange Drums —

Narrow Sizes — Dimensional and Technical Data

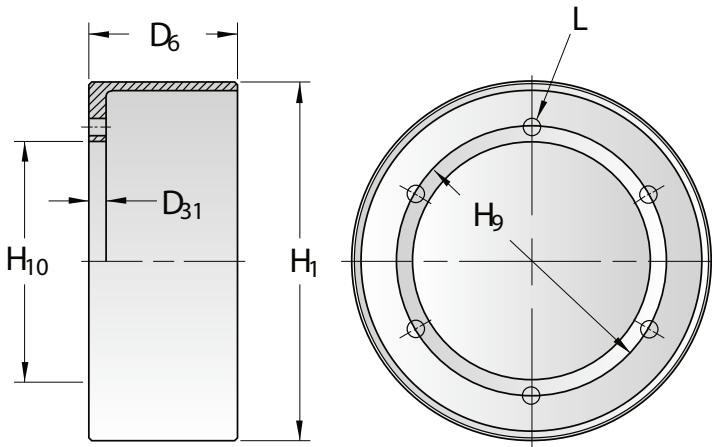

Size	Drum Part Numbers		Dual Elements	
	Single Elements Thru Holes	Tapped Holes	Thru Holes	Tapped Holes
11.5VC500	408290	408291	408306	408307
14VC500	408283	408284	408308	408309
16VC600	408292	408293	408310	408311
20VC600	408294	408295	408312	408313
24VC850	408296	408297	408314	411828
28VC650	409479	408299	408316	408317
33VC650	408300	408301	408318	408319
37VC650	408302	408303	408320	408321
42VC650	408304	408305	408322	408323

ENGL ISH

D ₃₁	(Dimensions in inches)			Thru	L Holes Tapped	L Holes No.	Single Drum D ₆	Weight (lb)	Wk ² (lb-ft ²)	L Holes (in)	D ₆ (lb)	Dual Drum		
	H ₁	H ₉	H ₁₀									Weight (lb-ft ²)	Size Wk ²	
11.5VC500	0.75	11.5	7.250	6.250	0.53	½-13	6	6.50	46	9	12	13.13	83	16
14VC500	0.75	14	9.250	8.250	0.53	½-13	12	6.50	66	19	12	13.13	139	40
16VC600	0.75	16	9.625	8.250	0.78	¾-10	8	7.75	94	35	8	15.63	175	66
20VC600	1.00	20	12.000	10.500	0.78	¾-10	12	7.75	139	78	12	15.63	234	136
24VC850	1.00	24	16.000	14.625	0.78	¾-10	12	8.25	178	148	16	16.38	293	258
28VC650	1.00	28	20.000	18.500	0.78	¾-10	16	8.25	231	269	16	16.38	346	472
33VC650	1.00	33	21.500	19.500	0.78	¾-10	14	8.25	312	486	24	16.44	507	827
37VC650	1.00	37	27.000	25.000	0.78	¾-10	18	8.25	340	691	32	16.44	553	1172
42VC650	1.13	42	31.000	29.000	0.78	¾-10	20	8.25	424	1100	36	16.44	662	1809

SI

D ₃₁	(Dimensions in millimeters)			Thru	L Holes Tapped	L Holes No.	Single Drum D ₆	Mass (kg)	Wk ² (kg-m ²)	L Holes (mm)	D ₆ (kg)	Dual Drum		
	H ₁	H ₉	H ₁₀									Mass (kg-m ²)	Size Wk ²	
11.5VC500	19	292	184,2	158,8	13	½-13	6	165	21	0,38	12	333	38	0,67
14VC500	19	356	235,0	209,6	13	½-13	12	165	30	0,80	12	333	63	1,68
16VC600	19	406	244,5	209,6	20	¾-10	8	197	43	1,47	8	397	79	2,77
20VC600	25	509	304,8	266,7	20	¾-10	12	197	63	3,28	12	397	106	5,80
24VC650	25	610	406,4	371,5	20	¾-10	12	210	81	6,22	16	416	133	10,84
28VC650	25	711	508,0	469,9	20	¾-10	16	210	105	11,30	16	416	158	19,82
33VC650	25	838	546,1	495,3	20	¾-10	14	210	141	20,41	24	418	230	34,73
37VC650	25	940	685,8	635,0	20	¾-10	18	210	154	29,02	32	418	251	49,22
42VC650	29	1067	787,4	736,6	20	¾-10	20	210	192	46,20	36	418	300	75,98

Notes:

Tolerance (H₁)
+0.000/-0.010 in
(+0,00/-0,25 mm)

Tolerance (H₁₀)
+0.003/-0.010 in
(+0,08/-0,00 mm)

Tapped L Holes meet
American National Standards
for United Screw Threads.

Airflex[®] VC Mounting Components

Form VC-528 — Internal Flange Drums —

Wide Sizes — Dimensional and Technical Data

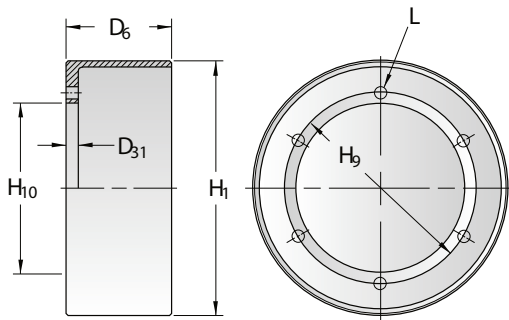

Size	Drum Part Numbers Having		Size	Drum Part Numbers Having	
	Male Register	Female Register		Male Register	Female Register
14VC1000	411111	N/A	42VC1200	409947	409948
16VC1000	409506	410320	46VC1200	409980	409981
20VC1000	410087	410088	52VC1200	409715	409716
24VC1000	409794	409795	51VC1600	409711	409712
28VC1000	409537	409538	60VC1600	411501	411502
32VC1000	410824	410825	66VC1600	413727	413726
38VC1200	409474	409475	76VC1600	515149	515150
			76VC2000	515382	515383

ENGL ISH

Size	(Dimensions in inches)				L Holes No	L Holes Size	D ₃₁ (in)	Male Register Drums			Female Register Drums	
	D ₆	H ₁	H ₉	H ₁₀				Weight (lb)	Wk ² (lb-ft ²)	D ₃₁ (in)	Weight (lb)	Wk ² (lb-ft ²)
14VC1000	11.50	14	9.250	8.250	12	1/2-13 NC	0.88	122	35	N/A	N/A	N/A
16VC1000	11.50	16	11.500	10.000	See Notes	0.78	1.00	130	38	0.88	94	37
20VC1000	11.50	20	15.000	13.500	See Notes	0.78	1.00	169	112	0.88	164	109
24VC1000	11.50	24	16.000	14.625	See Notes	0.78	1.00	225	192	0.88	215	186
28VC1000	11.50	28	20.000	18.500	See Notes	0.78	1.00	295	350	0.88	282	338
32VC1000	11.50	32	21.000	19.000	See Notes	0.78	1.00	371	559	0.88	352	537
38VC1200	13.63	38	27.000	25.000	See Notes	0.78	1.00	552	1214	0.88	530	1173
42VC1200	13.63	42	31.000	29.000	See Notes	0.78	1.13	582	1567	1.00	550	1510
46VC1200	13.63	46	34.500	32.500	See Notes	1.03	1.25	729	2357	1.13	700	2276
52VC1200	13.88	52	40.000	38.000	See Notes	1.06	1.25	852	3552	1.13	820	3425
51VC1600	18.13	51	40.000	38.000	See Notes	1.06	1.25	890	4145	1.13	860	4035
60VC1600	17.75	60	46.000	42.000	24	1.56	1.75	1640	8810	1.63	1590	8575
66VC1600	18.25	66	48.000	44.000	See Notes	1.56	1.75	1905	15070	1.50	1770	14340
76VC1600	18.25	76	58.000	54.000	See Notes	1.56	1.75	2230	19861	1.50	2060	18542
76VC2000	22.25	76	58.000	54.000	See Notes	1.56	1.75	2780	25000	1.50	2640	23900

Size	(Dimensions in millimeters)				L Holes No	L Holes Size	D ₃₁ (mm)	Male Register Drums			Female Register Drums	
	D ₆	H ₁	H ₉	H ₁₀				Weight (kg)	Wk ² (kg-m ²)	D ₃₁ (mm)	Weight (kg)	Wk ² (kg-m ²)
14VC1000	292	356	235,0	209,6	12	1/2-13 NC	22	55	1,47	N/A	N/A	N/A
16VC1000	292	406	292,1	254,0	See Notes	20	25	59	1,60	22	43	1,55
20VC1000	292	508	381,0	342,9	See Notes	20	25	77	4,70	22	74	4,58
24VC1000	292	610	406,4	371,5	See Notes	20	25	102	8,06	22	97	7,81
28VC1000	292	711	508,0	469,9	See Notes	20	25	134	14,70	22	128	14,20
32VC1000	292	813	533,4	482,6	See Notes	20	25	168	23,48	22	159	22,55
38VC1200	346	965	685,8	635,0	See Notes	20	25	250	50,99	22	240	49,27
42VC1200	346	1067	787,4	736,6	See Notes	20	29	264	65,81	25	249	63,42
46VC1200	346	1168	876,3	825,5	See Notes	26	32	330	98,99	29	317	95,59
52VC1200	353	1321	1016,0	965,2	See Notes	27	32	386	149,2	29	371	143,9
51VC1600	461	1295	1016,0	965,2	See Notes	27	32	403	174,1	29	390	169,5
60VC1600	451	1524	1168,4	1066,8	24	40	44	743	370,0	41	720	360,2
66VC1600	464	1676	1219,2	1117,6	See Notes	40	44	863	632,9	38	802	602,3
76VC1600	464	1930	1473,2	1371,6	See Notes	40	44	1011	837,0	38	934	781,0
76VC2000	565	1930	1473,2	1371,6	See Notes	40	44	1264	1050	38	1200	1005

Notes:

For size 14, drum furnished without male register.

For size 16, male drum has tapped holes. Female has drilled holes. See VC510

Tolerance (H₁)
+0.000/-0.010 in
(+0,00/-0,25 mm)

Tolerance (H₁₀)
14 thru 51 +0.003/-0.000 in
(+0,08/-0,00 mm)

60 thru 76 +0.005/-0.000 in
(+0,13/-0,00 mm)

For sizes 16-28,
14 Holes based upon a
16 hole pattern. Two holes 180°
apart not used.

For sizes 32, 52 & 51, 22 Holes
based upon a 24 hole pattern.
Two holes 180°
apart not used.

For sizes 38 & 46, 30
Holes based upon a 32
hole pattern. Two holes
180° apart not used.

For sizes 42 & 66, 34 Holes
based upon a 36 holes
pattern. Two holes 180°
apart not used.

For sizes 76, 46 Holes based
upon a 48 hole pattern. Two
holes 180° apart not used.
See Form VC 510 for male
and female register drums.

Airflex® VC Mounting Components

Form VC-514 — Drum Hubs — Narrow Sizes

— Dimensional and Technical Data

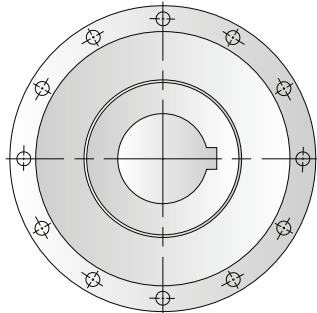
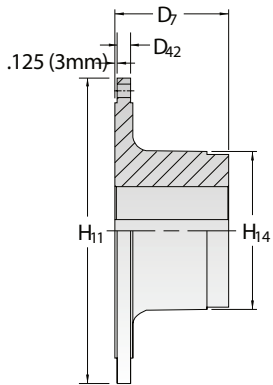

Thru or Tapped Holes

Size	Drum Hub Part Numbers for Single Element		Dual Elements	
	Thru Holes	Tapped Holes	Thru Holes	Tapped Holes
11.5VC500	406959	406960	406945	406946
14VC500	406961	406962	406961	406962
16VC600	406963	406964	407027	407028
20VC600	406965	406966	406376	407029
24VC650	406967	406968	405625	405626
28VC650	406969	406970	405628	405629
33VC650	406971	406972	405631	405632
37VC650	406973	406974	405634	405635
42VC650	406975	407000	405637	405638

Size	ENGL ISH H ₁₁ (in)	For Single Elements		D ₇ (Dimensions in inches)	D ₄₂ (Dimensions in inches)	H ₁₄	For Dual Elements		D ₇ (Dimensions in inches)	D ₄₂ (Dimensions in inches)	H ₁₄
		Weight (lb)	Wk ² (lb-ft ²)				Weight (lb)	Wk ² (lb-ft ²)			
11.5VC500	8.25	35	2	5.00	0.63	6.00	43	2	7.00	0.63	6.00
14VC500	10.25	64	4	5.75	0.75	7.50	64	4	5.75	0.75	7.50
16VC600	11.13	64	4	5.75	0.63	7.50	82	6	6.50	0.75	8.00
20VC600	13.50	95	9	6.50	0.75	8.50	124	13	7.00	0.75	10.00
24VC650	17.50	124	19	6.50	0.75	9.00	215	42	7.50	1.00	12.00
28VC650	21.50	240	59	8.00	0.75	11.50	292	85	8.00	1.00	13.00
33VC650	23.00	347	93	9.00	0.75	13.50	395	123	9.50	1.00	14.50
37VC650	28.50	398	159	9.00	0.75	13.50	528	240	10.00	1.00	15.50
42VC650	32.50	545	243	9.00	0.75	15.00	647	413	11.00	1.00	16.50

Size	SI H ₁₁ (mm)	For Single Elements		D ₇ (Dimensions in millimeters)	D ₄₂ (Dimensions in millimeters)	H ₁₄	For Dual Elements		D ₇ (Dimensions in millimeters)	D ₄₂ (Dimensions in millimeters)	H ₁₄
		Mass (kg)	Wk ² (kg-m ²)				Mass (kg)	Wk ² (kg-m ²)			
11.5VC500	210	16	0,08	127	16	152	19	0,08	178	16	152
14VC500	260	29	0,17	146	19	191	27	0,17	146	19	191
16VC600	283	29	0,17	146	16	191	37	0,25	165	19	203
20VC600	343	43	0,38	165	19	216	56	0,55	178	19	254
24VC650	445	56	0,80	165	19	229	97	1,76	191	25	305
28VC650	546	109	2,48	203	19	292	132	3,57	203	25	330
33VC650	584	157	3,91	229	19	343	179	5,17	241	25	368
37VC650	724	180	6,68	229	19	343	239	10,08	254	25	394
42VC650	826	247	10,21	254	19	381	293	17,35	279	25	419

Notes:

Table data based upon minimum bores.

Airflex[®] VC Mounting Components

Form VC-516 — Drum Hubs — Wide Sizes — Dimensional and Technical Data

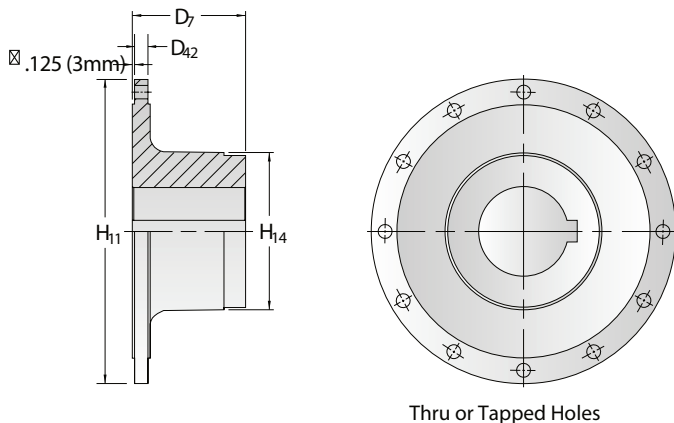

Size	Hub Part Numbers for Single Drums		Dual Drums	
	Thru Holes	Tapped Holes	Thru Holes	Tapped Holes
14VC1000	411113			
16VC1000	407069	407070	410487	407072
20VC1000	407073	407074	407075	407076
24VC1000	405625	405626	407077	407078
28VC1000	405628	405629	408031	407081
32VC1000	405631	405632	407082	407083
38VC1200	405634	405635	406841	407084
42VC1200	405637	405638	410990	407085
46VC1200	405640	405641	408001	407086
52VC1200	407079	407080	407876	407087
51VC1600	408585		408586	
60VC1600	411500		411691	
66VC1600			413725	
76VC1600			515147	
76VC2000			515147	

Size	D ₄₂ (in)	H ₁₁ (in)	For Single Element		D ₇ (in)	H ₁₄ (in)	Weight (lb)	For Dual Element		H ₁₄ (in)
			Weight (lb)	Wk ² (lb · ft ²)				Wk ² (lb · ft ²)	D ₇ (in)	
14VC1000	0.75	10.25	70	5	7.00	7.50				
16VC1000	0.75	13.00	97	9	5.50	9.50	199	19	10.00	9.50
20VC1000	0.75	16.50	150	21	7.00	10.00	203	32	9.50	11.00
24VC1000	1.00	17.50	215	44	7.50	12.00	271	50	9.50	12.75
28VC1000	1.00	21.50	297	82	8.00	13.00	370	99	10.00	14.00
32VC1000	1.00	22.50	407	127	9.50	14.50	574	185	12.00	16.50
38VC1200	1.00	28.50	521	236	10.00	15.50	806	368	13.00	18.50
42VC1200	1.00	32.50	677	378	11.00	16.50	1233	653	17.00	20.00
46VC1200	1.25	36.50	813	577	11.00	17.00	1316	856	17.00	20.00
52VC1200	1.25	42.00	1125	1000	12.50	18.50	1803	1514	17.00	23.00
51VC1600	1.25	42.00	1475	1150	15.00	20.00	2303	1993	20.00	25.00
60VC1600	1.75	49.00	2526	3034	16.00	26.00	4143	4967	24.00	30.00
66VC1600	2.00	51.50	4940	6760	20.00	34.00	6450	7800	24.00	34.00
76VC1600	2.00	61.50	7100	14970	24.00	38.50	7800	15576	27.00	38.50
76VC2000	2.00	61.50	7100	14970	24.00	38.50	7800	15576	27.00	38.50

Size	D ₄₂ (mm)	H ₁₁ (mm)	For Single Element		D ₇ (mm)	H ₁₄ (mm)	Mass (kg)	For Dual Element		H ₁₄ (mm)
			Mass (kg)	Wk ² (kg · m ²)				Wk ² (kg · m ²)	D ₇ (mm)	
14VC1000	19	260	32	0,21	178	191				
16VC1000	19	330	44	0,38	140	241	90	0,80	254	241
20VC1000	19	419	68	0,88	178	254	92	1,34	241	279
24VC1000	25	445	97	1,85	191	305	123	2,10	241	324
28VC1000	25	546	135	3,44	203	330	168	4,16	254	356
32VC1000	25	572	184	5,33	241	368	260	7,77	305	419
38VC1200	25	724	236	9,91	254	394	365	15,46	330	470
42VC1200	25	826	307	15,88	279	419	559	27,43	432	508
46VC1200	32	927	368	24,23	279	432	596	35,95	432	508
52VC1200	32	1067	510	42,00	318	470	817	63,59	432	584
51VC1600	32	1067	668	48,30	381	508	1043	83,71	508	635
60VC1600	44	1245	1144	127,4	406	660	1877	208,6	610	762
66VC1600	51	1308	2238	283,9	508	864	2922	327,6	610	864
76VC1600	51	1562	3217	628,7	610	978	3533	654,2	686	978
76VC2000	51	1562	3217	628,7	610	978	3533	654,2	686	978

Notes:

0.25 in (6 mm) for sizes 66 and 76.

Table data based upon minimum bores.

Airflex® Standard Air Tank Group

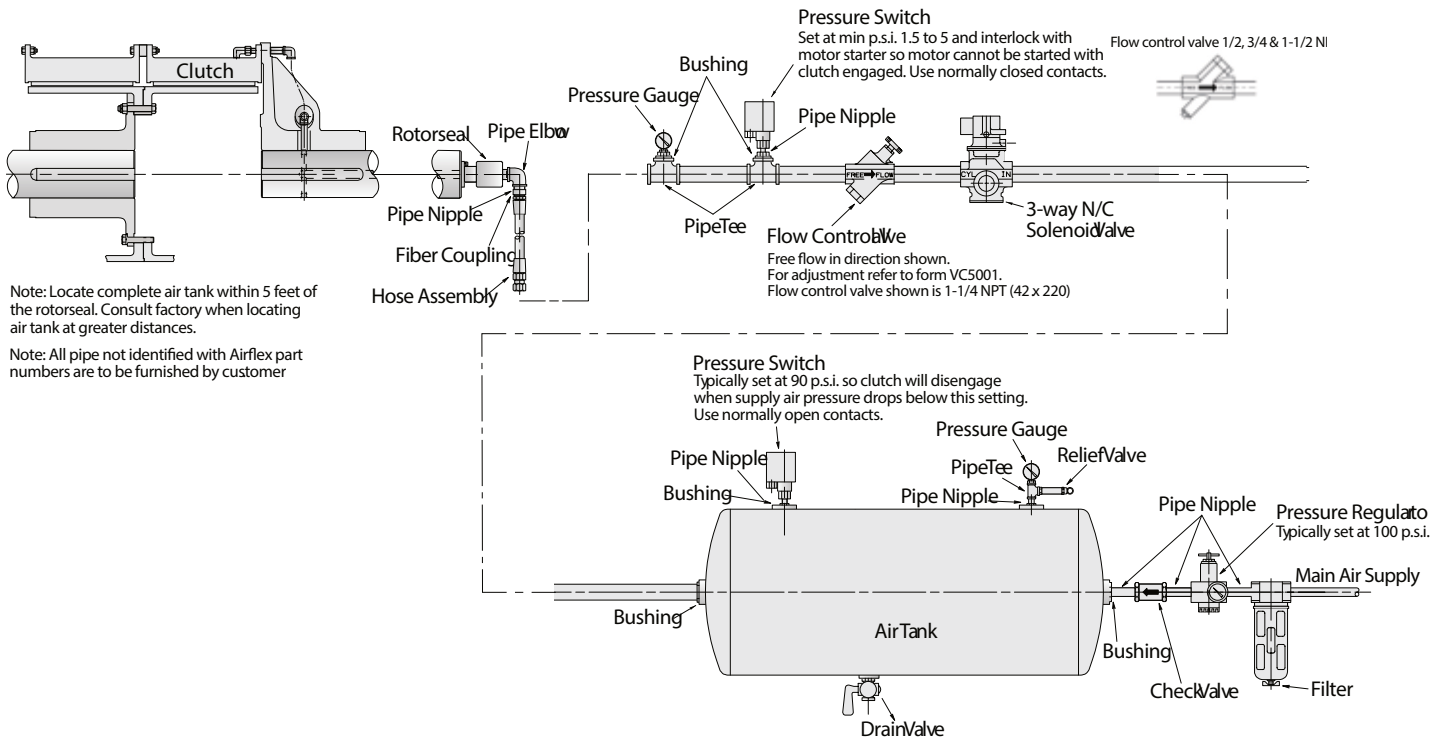

Rotorseals and Rotorseal Assemblies

B3, C2

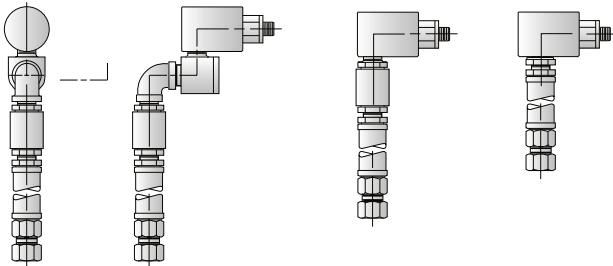

RH Rotorseals

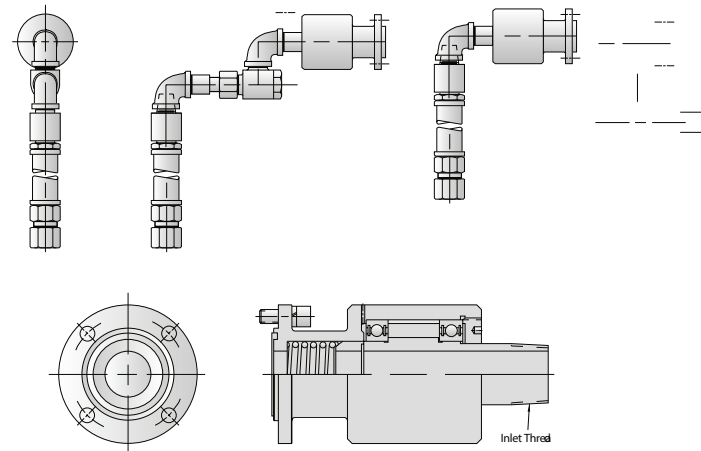

	Clutch	Pipe Size	Rotorseal G group	Size
Single	11.5VC500-16VC600	1/2	104921	B3
	20VC600-28VC650	1/2	104907	C2
	33VC650-42VC650	3/4	104908AA	RH
Dual	11.5VC500-20VC600	1/2	104907	C2
	24VC650-28VC650	3/4	104908AA	RH
	33VC650-37VC650	1	104909AA	1" RH
Single	42VC650	1 1/4	104910AA	1 1/4 RH
	14VC1000-20VC1000	1/2	104907	C2
	24VC1000-28VC1000	3/4	104908AA	3/4 RH
	32VC1000	1	104909AA	1" RH
	38VC1200-42VC1200	1 1/4	104910AA	1 1/4 RH
	46VC1200-52VC1200	1 1/2	105519AA	1 1/2 RH
Dual	51VC1600-66VC1600	1 1/2	105519AA	1 1/2 RH
	76VC1600	2	107815AA	2" RH
	16VC1000	3/4	104908AA	3/4 RH
	20VC1000-24VC1000	1	104909AA	1" RH
	28VC1000-32VC1000	1 1/4	104910AA	1 1/4 RH
	38VC1200	1 1/2	105519AA	1 1/2 RH
	42VC1200-46VC1200	1 1/2	105519AA	1 1/2 RH
	52VC1200-66VC1600	1 1/2	105519AA	1 1/2 RH
	76VC1600	2	107815AA	2" RH
	76VC2000	2	107815AA	2" RH

*For dimensional information, see I.Q.M. RS 9010 and RS 9031.

Rotorseals shown are for typical arrangements only.

Airflex Standard Electrical Controls

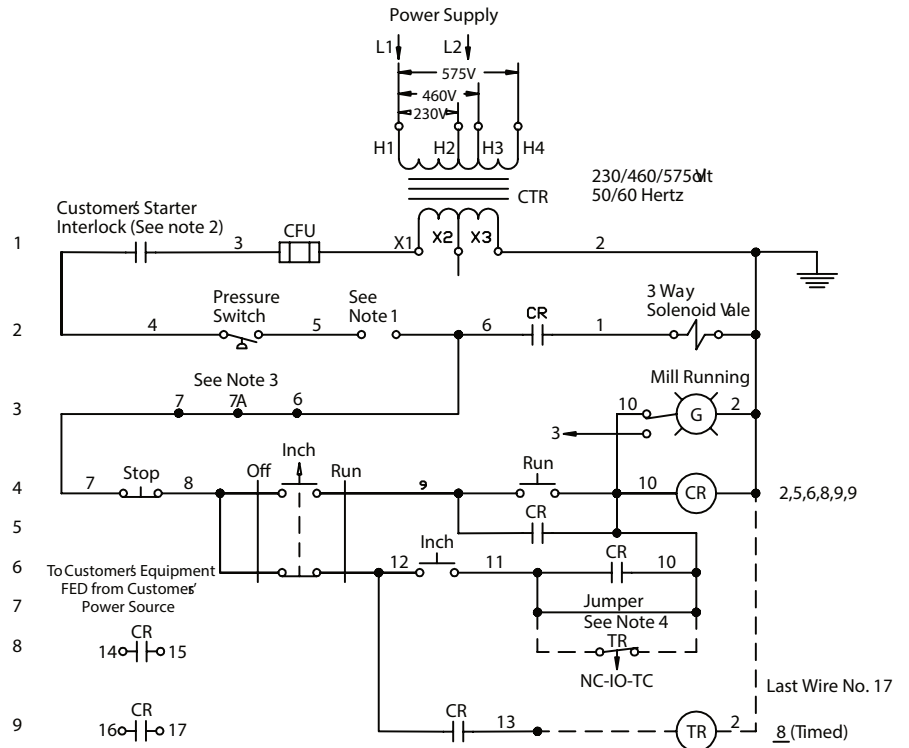

Normal mill starting procedure is to bring the motor up to operating speed and then engage the clutch to accelerate the mill. Airflex offers a simple, but very reliable system for clutch control. The system consists of two parts: the pneumatic and electrical portions.

A pressure actuated limit switch prevents the motor from starting if air pressure is applied to the clutch. It also insures that sufficient air volume and pressure is available before a start can be made. Rate of torque build-up and mill acceleration is determined by the setting of a manually adjusted flow control valve.

Interlocks in the pneumatic controls, furnished by Airflex are tied in electrically to the motor and clutch control. They regulate the electrical signal to the solenoid valve. The standard control permits starting, stopping and where applicable, inching of the mill.

Controls can be custom built to meet most operational and environmental requirements.

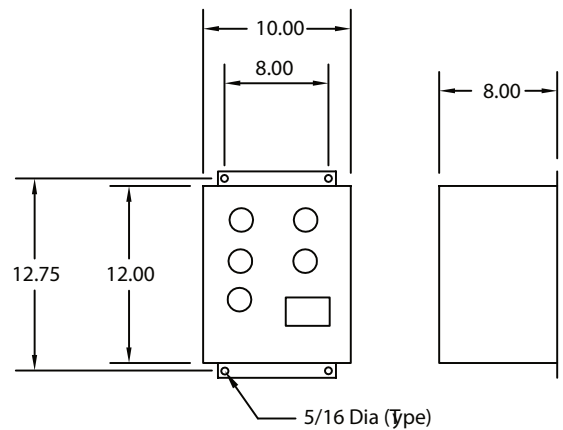

Enclosure for Standard Panel

Electrical Control Equipment

Bill of Mat'l	Panel No	Remark
	209811-01	Std. Panel w/PB's, Selector, Light in Door
105448	209811-02	Std. Panel w/219005-07 Operator Station
	209811-03	Timed Inching Panel w/PB's, Selector, Light in Door
105449	209811-04	Timed Inching Panel w/219005-07 Operator Station
	209811-05	Std. Panel (Similar to 209811-02 Except NEMA 4 Encl.)
	209811-15	Std. Panel w/Extra Terminal and NEMA 12 Encl.
	209811-23	Timed Panel w/219005-18 Station, NEMA 4 Encl.
	209811-24	Timed Panel (Sim. to 209811-03 Except NEMA 4)

Airflex® Slip Detection Control

Airflex® also offers a unique clutch slip detection control which provides protection for grinding mill drive systems.

Danfoss's clutch slip detection control has been developed to prevent costly damage to the motor, clutch and other grinding mill drive train components. This system continuously monitors clutch performance during start-up and running operations.

Detects fast starts

- Gives a warning that a fast start has occurred. This condition (if not corrected) may eventually lead to drive train component damage.

Detects long starts

- Start is aborted if excessive slip time occurs preventing costly downtime.
- Detects clutch slippage during operation.
- The control system prevents damage by detecting slippage during normal operation and automatically disengaging the clutch.



Operation

Monitors start-ups

During a mill start, the control monitors the time required to engage the clutch and bring the mill to full RPM (clutch lock-up). If the clutch locks up too quickly, a warning light on the control enclosure will illuminate alerting the operator.

If the clutch does not lock up (full mill RPM not achieved) within a predetermined time factor, the control will abort the start (disengage the clutch). A warning light will also illuminate to indicate the clutch was automatically disengaged because of excessive slippage.

Another start cannot be attempted until the control is physically reset at the mill. This prevents successive start attempts from a remote control room when there is a potential problem.

Monitors during mill operation

While running, the RPM of the input and output shaft are continually compared. If for some reason the clutch begins to slip, the control will sense the difference in RPM and disengage the clutch, again illuminating a warning light and requiring the control to be physically reset.

For further information, please consult the factory.

Reduces
Downtime!

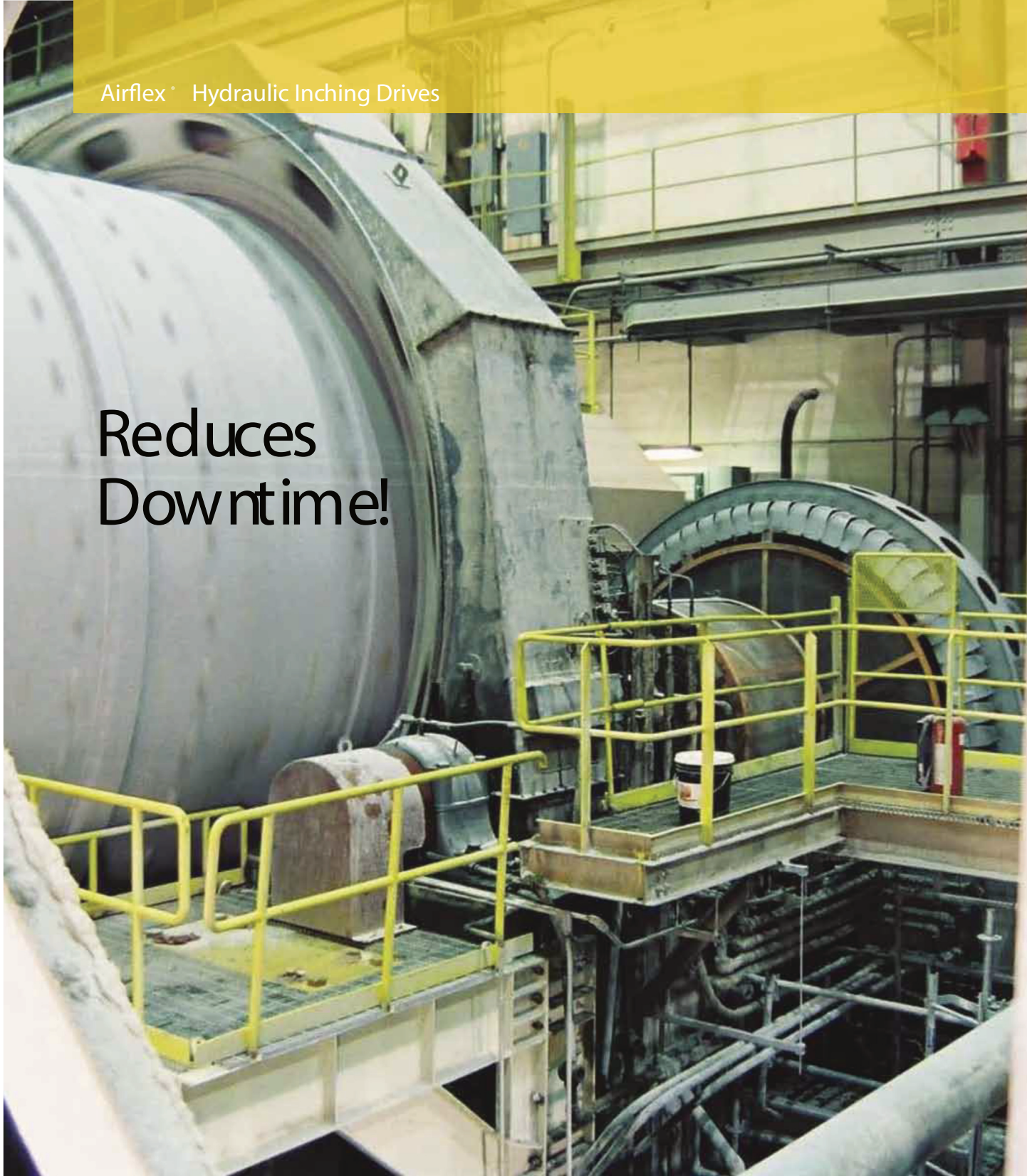

Hydraulic Inching Drives for Grinding Mills

Portable – single point lift system

Extends clutch life – reduces maintenance costs

Simple controls and connections – faster maintenance

Danfoss's expertise in Hydraulic Drives has enabled customer specific solutions to be realized in many industries. The latest of these innovations is the introduction of Hydraulic Inching Drives for Grinding Mills for the mining industry. Hydraulic Inching Drives allows easy maintenance of Grinding Mills and are available in a variety of configurations and sizes. The modular design of these units provides best in class flexibility of operation during maintenance activities. These systems are designed to meet or exceed all applicable standards, including ISO, JIC, and NFPA.



Hydraulic Power Unit

Providing power to the Drive System, the Hydraulic Power Unit has a Danfoss Hydrostatic Transmission Pump close coupled to the electric motor. The reservoir is sealed and filled only by an on-board pump with filter. The electric drive motor is available in 50 Hz or 60 Hz with a large range of voltages. Low leak, quick disconnects on the hoses provide means to cleanly connect the Drive System, and are assembled to eliminate the possibility of incorrect rotation. The operator control station allows the qualified technician to accurately drive the mill to the optimal position enabling maintenance. The electrical power supply cable stows on the skid while not in use and the optional control station pendant gives precise control where you need it.



Providing power to the Drive System, the Hydraulic Power Unit has a Danfoss Hydrostatic Transmission Pump close coupled to the electric motor

Dimensional Data

Hydraulic Power Unit

Dimensions in mm (in)

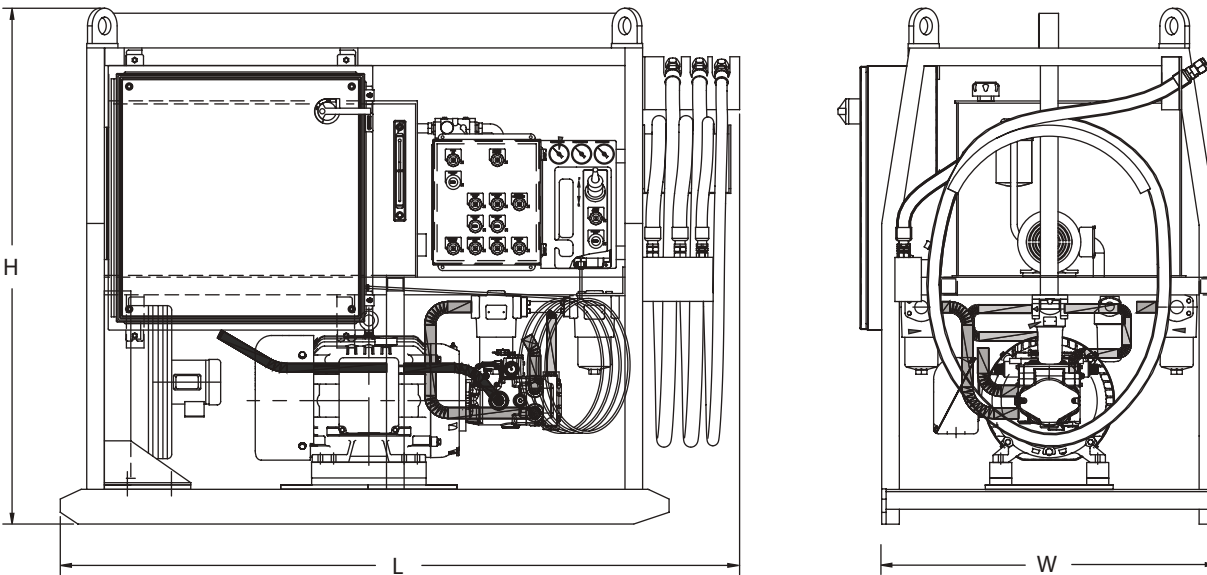

Electrical Motor Power

	25 hp	75 hp	150 hp	300 hp
Tank Volume in Gallons	60	60	100	200
Approximate "L"	1,880 (74)	2,311 (91)	2,616 (103)	3,429 (135)
Approximate "H"	1,448 (57)	1,701 (67)	2,184 (86)	2,692 (106)
Approximate "W"	990.6 (39)	1,067 (42)	1,346 (53)	1,524 (60)

Drive System

The Industrial planetary style torque multiplier with hydraulic motor drive input turns the pinion shaft at the required speed. Automatic torque overload protection is standard and can be adjusted as needed from the operator control station. The automatic brake can be manually set or released as desired for flexible operation. The foot mounting arrangement can be customized to any situation. Coupling engagement is manual lever operated, and additional drive couplings as well as base plates can be installed on other mills.

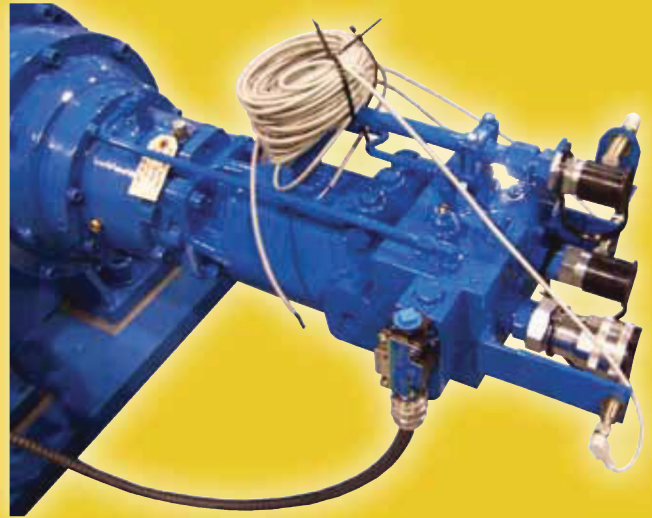

Automatic torque overload protection is standard and can be adjusted as needed from the operator control station.

Dimensional Data

Drive System

Dimensions in mm (in)

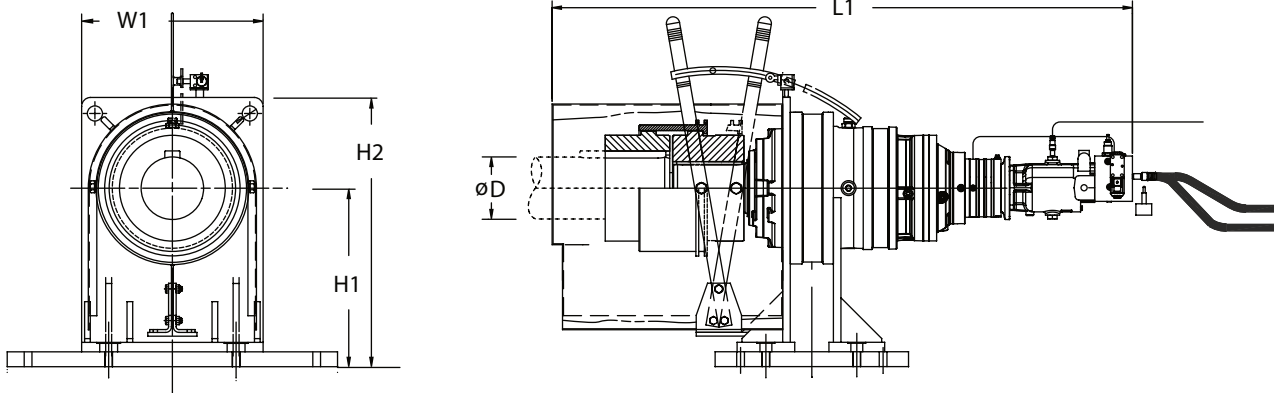

Gear Box/Drive Table

Base Stage	Power hp	Torque ft-lb	Speed rpm	Approximate D	Drive L1	Dimensions	H1	H2	W1
SL300	9.0	22,861	2.00	120 (4.72)	1,277 (50.30)		267 (10.51)	534 (21.02)	534 (21.02)
SL400	20.0	49,526	2.00	130 (5.12)	1,307 (51.48)		267 (10.51)	534 (21.02)	534 (21.02)
SL600	25.0	82,544	1.60	160 (6.30)	1,412 (55.61)		306 (12.05)	612 (24.10)	612 (24.10)
SL850	45.0	114,972	2.00	170 (6.69)	1,554 (61.19)		339 (13.35)	678 (26.70)	678 (26.70)
SL1200	55.0	172,752	1.70	200 (7.87)	1,699 (66.91)		381 (15.00)	762 (30.00)	762 (30.00)
SL1800	90.0	229,944	2.00	210 (8.27)	1,820 (71.68)		426 (16.77)	852 (33.54)	852 (33.54)
SL2500	127.0	333,502	2.00	240 (9.45)	2,048 (80.67)		485 (19.13)	972 (38.26)	972 (38.26)
SL3500	130.0	477,576	2.00	280 (11.02)	2,210 (87.05)		531 (20.91)	1,062 (41.82)	1,062 (41.82)
SL5000	250.0	651,262	2.00	340 (13.39)	2,533 (99.75)		588 (23.15)	1,176 (46.30)	1,176 (46.30)
SL7500	300.0	787,800	2.00	400 (15.75)	3,248 (127.90)		696 (27.40)	1,392 (54.80)	1,392 (54.80)

Features and Benefits

- Torque range up to 785,000 lb.ft (1,070,000 Nm)
- Speeds up to 2 rpm
- Maximum torque limiting built into the hydraulic pump
- Precision Electric Joystick controller ensures accurate positioning and saves time
- Automatic brake optimizes performance
- Inching while main motor is being serviced
- Frozen charge detection
- Highly efficient maintenance solution
- Comprehensive instruments including pressure, temperature, and optional mill position (position feedback device required) monitor key functions providing the operator complete control
- Sealed reservoir ensures long service life
- Standard filtered reservoir fill system with suction wand
- Power supply cable with receptacle makes start up quick
- Mechanical and electrical interlocks
- Standard shiftable coupling sleeve and mating hub easy to engage/disengage
- Additional coupling hubs and base-plates to share drive with other mills

Reliable and cost effective maintenance solution.

Complete range of optional features

- Custom torque and speed ranges available on request
- Pendant controller for remote operation
- Special epoxy paint for harsh environments
- 50Hz - 60Hz electrical system including high voltage motors
- Multi-lingual Installation, Operation and Maintenance manuals

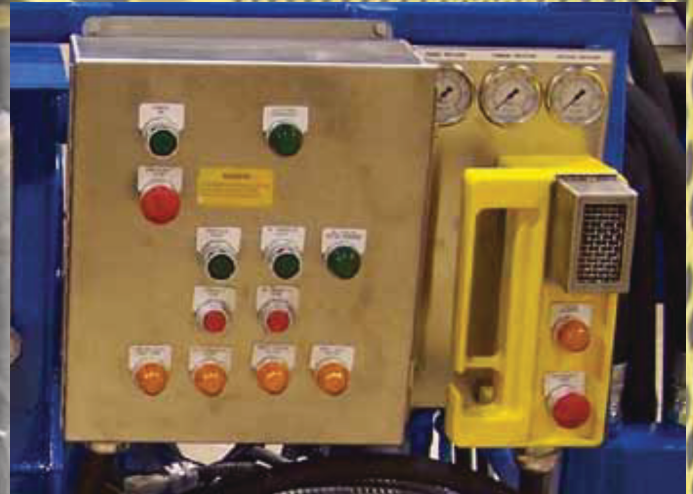

Preliminary Clutch Selection Guide

		Motor Horse Power																									
		100	125	150	175	200	250	300	350	400	450	500	600	700	800	900	1000	1250	1500	1650	1750	2000	2200	2250	2500	2750	
Clutch Shaft RPM (60 Hz. Synchronous speeds)	120					F											PP										
	124		E						N	FF		P															UU
	129					L	M			H						S								TT			
	133								EE																		
	138	D								N																	
	144						F				H	FF						T									
	150							M								R											
	157				E						N		P								RR				SS		
	164						L					H						S									
	172									EE									T								
	180						F					N	FF	P													
	190																										
	200							L					H		P							T					
	212	C							F				N														
	225				D						M						P									RR	
	240							L	F			EE	H								S	T					
	257												N				P									T	
	277									F	M			H	FF			R						PP			
	300								E			F			N											T	
	327									L		M			N		P								PP	T	
360			C								F				N								S		PP		
400		B									L		M				FF				R						
450								D			E		F				P									PP	
514												L	F		EE	N			P			GG					
600													CC	L	M		EE	FF			MM						
720						C							K	CC	L	M			LL								
900		A										BB	X		K		KK										
1200								AA																			

Selection Guide Parameters:

Minimum Torque Service Factor - 2

Minimum Operating Air Pressure - 100 psig

Maximum Contact Velocity - 4,500 fpm

Inching with clutch permitted at 3500 FPM or less (unshaded area).

Consult factory for applications which exceed these specifications.

For motor ratings up to 3000 hp (2250 kW) to determine the proper clutch size and and clutch shaft speeds up to 277 rpm, the starting time. The various starts are clutch element selected from this chart obtained by changing the rate of pressure build-up, hence the rate of torque build-up and in most cases can be used for inching the clutch. and spotting of the mill.

For larger power motors and higher clutch shaft speeds a more thorough analysis of the mill is required. Various mill starts can be simulated by computer modeling

3000	3500	4000	4400	4800	5000	5500	6000	6500	7000	7500	8000	8500	9000	9500	10000	10500	11000	11500	12000	12500	13000	13500			
																								120	
																									124
UU			WW							ZZ						QQ									129
																									133
	VV																								138
																									144
									YY											QQ					150
																									157
						WW																			164
TT																									172
	UU																								180
																									190
	TT			VV																	QQ				200
																									212
SS	TT																								225
											WW														240
																	YY								257
RR																									277
											W														300
					TT			UU																	327
																									360
		RR		SS																					400
PP																									450
																									514
																									600
																									720
																									900

Clutch Shaft RPM (60 Hz, Synchronous speeds)

A	11.5VC500	J	42VC650	T	46VC1200
B	14VC500	X	14VC1000	U	52VC1200
C	16VC600	K	16VC1000	V	51VC1600
D	20VC600	L	20VC1000	W	60VC1600
E	24VC650	M	24VC1000	Y	66VC1600
F	28VC650	N	28VC1000	Z	76VC1600
G	33VC650	P	32VC1000	Q	76VC2000
H	37VC650	R	38VC1200		
		S	42VC1200		

This guide is based on minimum data only.
Final clutch selection must be approved by the Airflex Division's Application Engr. Dept. in Cleveland, Ohio.

Double letters indicate dual elements

VC Clutch Total Application

Size		Part Number w/o Axial	Lock	Part Number w/Axial	Lock	Connection	Rotorseal Assembly	AirTank Standard	Group Premium	
Single	11.5VC500	104601				½	104921	N/A	N/A	
Narrow	14VC500	104602				½	104921	N/A	N/A	
	16VC600	104603				½	104921	N/A	N/A	
	20VC600	104604				½	104907	108702	108602	
	24VC650	104605				½	104907	108702	108602	
	28VC650	104606				½	104907	108702	108602	
	33VC650	104607				¾	104908AA	108703	108603	
	37VC650	104608				¾	104908AA	108703	108603	
	42VC650	104609				¾	104908AA	108703	108603	
	Dual	11.5VC500	104610				½	104907	108702	108602
Narrow	14VC500	104611				½	104907	108702	108602	
	16VC600	104612				½	104907	108702	108602	
	20VC600	104613		104620		½	104907	108702	108602	
	24VC650	104614		104621		¾	104908AA	108703	108603	
	28VC650	104615		104622		¾	104908AA	108703	108603	
	33VC650	104616		104623		1	104909AA	108704	108604	
	37VC650	104617		104624		1	104909AA	108704	108604	
	42VC650	104618		104625		1¼	104910AA	108705	108605	
	Single	16VC1000	104680				½	104907	108702	108602
Wide	20VC1000	104681		104700		½	104907	108702	108602	
	24VC1000	104682		104701		¾	104908AA	108703	108603	
	28VC1000	104683		104702		¾	104908AA	108703	108603	
	32VC1000	104684		104703		1	104909AA	108704	108604	
	38VC1200	104685		104704		1¼	104910AA	108705	108605	
	42VC1200	104686		104705		1¼	104910AA	108705	108605	
	46VC1200	104687		104706		1½	105519AA	108706	108606	
	52VC1200	104688		104707		1½	105519AA	108706	108606	
	51VC1600	104689		104708		1½	105519AA	108707	108607	
	60VC1600	104690		104709		1½	105519AA	108707	108607	
	66VC1600	108111		108112		1½	105519AA	108707	108607	
	Dual	16VC1000	104720				¾	104908AA	108703	108603
	Wide	20VC1000	104721		104740		1	104909AA	108704	108604
		24VC1000	104722		104741		1	104909AA	108704	108604
28VC1000		104723		104742		1¼	104910AA	108705	108605	
32VC1000		104724		104743		1¼	104910AA	108705	108605	
38VC1200		104725		104744		1½	105519AA	108706	108606	
42VC1200		104726		104745		1½	105519AA	108707	108607	
46VC1200		104727		104746		1½	105519AA	108707	108607	
52VC1200		104728		104747		1½	105519AA	108708	108608	
51VC1600		104729		104748		1½	105519AA	108708	108608	
60VC1600		104730		104749		1½	105519AA	108708	108608	
66VC1600		Consult Factory		106972		1½	105519AA	108708	108608	
76VC1600		Consult Factory		108082		2	107815AA	108709	108609	
76VC2000		Consult Factory		108120		2	107815AA	108709	108609	

Grinding Mill Clutch Selection Worksheet

Following is the information required to properly size a clutch for a grinding mill application

Type of Mill -----

Motor HP-----

Clutch RPM -----

Mill Interia (empty@mill speed) -----

Mill RPM -----

Inside dia. of liners -----

Total weight of the charge -----

Nominal percent fill -----

Max air pressure -----

Clutch mounting (forward of reverse) -----

Cascade Angle (if available) -----

Bearings w/hydraulic lifters? (yes/no) -----

Products we offer:

- Cartridge valves
- DCV directional control valves
- Electric converters
- Electric machines
- Electric motors
- Gear motors
- Gear pumps
- Hydraulic integrated circuits (HICs)
- Hydrostatic motors
- Hydrostatic pumps
- Orbital motors
- PLUS+1® controllers
- PLUS+1® displays
- PLUS+1® joysticks and pedals
- PLUS+1® operator interfaces
- PLUS+1® sensors
- PLUS+1® software
- PLUS+1® software services, support and training
- Position controls and sensors
- PVG proportional valves
- Steering components and systems
- Telematics

Danfoss Power Solutions is a global manufacturer and supplier of high-quality hydraulic and electric components. We specialize in providing state-of-the-art technology and solutions that excel in the harsh operating conditions of the mobile off-highway market as well as the marine sector. Building on our extensive applications expertise, we work closely with you to ensure exceptional performance for a broad range of applications. We help you and other customers around the world speed up system development, reduce costs and bring vehicles and vessels to market faster.

Danfoss Power Solutions – your strongest partner in mobile hydraulics and mobile electrification.

Go to www.danfoss.com for further product information.

We offer you expert worldwide support for ensuring the best possible solutions for outstanding performance. And with an extensive network of Global Service Partners, we also provide you with comprehensive global service for all of our components.

Local address:

Hydro-Gear

www.hydro-gear.com

Daikin-Sauer-Danfoss

www.daikin-sauer-danfoss.com

Danfoss Power Solutions (US) Company
2800 East 13th Street
Ames, IA 50010, USA
Phone: +1 515 239 6000

Danfoss Power Solutions GmbH & Co. OHG
Krokamp 35
D-24539 Neumünster, Germany
Phone: +49 4321 871 0

Danfoss Power Solutions ApS
Nordborgvej 81
DK-6430 Nordborg, Denmark
Phone: +45 7488 2222

Danfoss Power Solutions Trading (Shanghai) Co., Ltd.
Building #22, No. 1000 Jin Hai Rd
Jin Qiao, Pudong New District
Shanghai, China 201206
Phone: +86 21 2080 6201

Danfoss can accept no responsibility for possible errors in catalogues, brochures and other printed material. Danfoss reserves the right to alter its products without notice. This also applies to products already on order provided that such alterations can be made without subsequent changes being necessary in specifications already agreed. All trademarks in this material are property of the respective companies. Danfoss and the Danfoss logotype are trademarks of Danfoss A/S. All rights reserved.