

■ **Safe PLC Interface Option MCB 108**

The MCB 108 option module is a galvanically isolated via an internal DC/DC converter and it can be fitted into option slot B.

What is the MCB108 Option:

It is designed to be built in between the Safe dual pole(plus/minus) on the Safe PLC and the Safe Stop input on FC302. The Safe PLC interface allows the safe output on the Safe PLC, to maintain the test pulses on the plus and minus output without impacting the sensor signal to safe stop T37.

Can be used in combination with safety devices to satisfy the requirement of IEC61800-5-2 SIL 2, ISO13849-1 PL d, and Category 3 (EN954-1) for Safe Torque Off (STO)

Electrical Data:

Input voltage (DC).....	18 to 28 V DC
Typical current input (DC).....	60 mAmp
Max. current input (DC).....	110 mAmp DC
Max. current inrush (DC).....	500 mAmp DC
Output voltage (DC)	20 V DC@Vin = 24 V
Turn on delay	1 mSec
Turn off delay	3 mSec

How to mount the MCB 108 option:

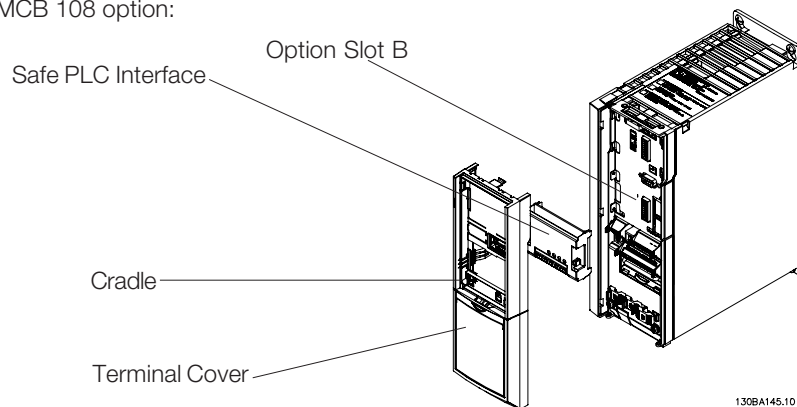

Following precautions have to be observed:

- The FC 302 with MCB 108 (including the connections between X31/9 and Terminal 37) must be placed inside an IP54 enclosure.
- Safe Stop activation (i.e. removal of 24 V DC voltage supply to terminal 37 by removing voltage to dual pole input of MCB 108) does not provide electrical safety.
- The safety device connected to the dual pole input of MCB 108 must itself fulfill the requirements of EN 954-1 Cat. 3 ISO13849-1 P Ld for interrupting the voltage/ current to MCB 108. This is also valid for the connections between MCB 108 and the safety device. You must read and follow the instructions for the safety device in order to connect it properly to MCB 108.

- The power to the frequency converter must be disconnected.
- Remove the LCP, the terminal cover and the cradle from the FC 300.
- Fit the MCB 108 option in slot B.
- Connect the control cables and relief the cables by the enclosed cable strips.
- Various systems must not be mixed.
- Fit the extended cradle and terminal cover.
- Replace the LCP.
- Connect the input to the Safety PLC's Output.
- Remove the connection between terminal 13 and 37 of the FC 302.

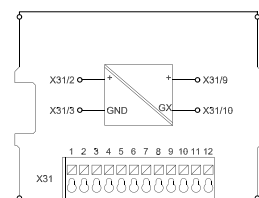

■ Commissioning Test

After installation and before first operation, perform a commissioning test of an installation or application making use of FC 302 Safe Stop with MCB 108.

Moreover, perform the test after each modification of the installation or application, which the FC 302 Safe Stop is part of.

A passed commissioning test is a necessary condition for fulfillment of EN 954-1 Cat. 3 ISO13849-1 P Ld of an application with FC 302 Safe Stop and MCB 108.

The commissioning test:

1. Remove the dual pole voltage supply to MCB 108 inputs by the safety device while the motor is driven by the FC 302 (i.e. mains supply is not interrupted). The test step is passed if the motor reacts with a coast and the mechanical brake (if connected) is activated.
2. Send Reset signal (via Bus, Digital I/O or [Reset] key). The test step is passed if the motor remains in the Safe Stop state and the mechanical brake (if connected) remains activated.
3. Reapply dual pole voltage supply to MCB 108 inputs. The test step is passed if the motor remains in the coasted state and the mechanical brake (if connected) remains activated.
4. Send Reset signal (via Bus, Digital I/O or [Reset] key). The test step is passed if the motor gets operational again.
5. The commissioning test is passed if all four test steps are passed.

Safety PLC Connection

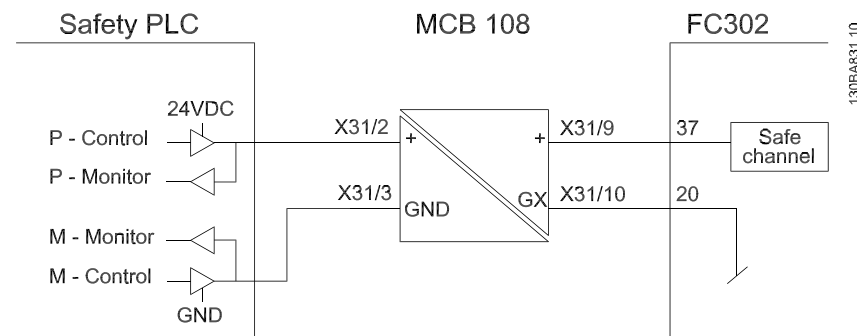

Wire inserting in MCB 108

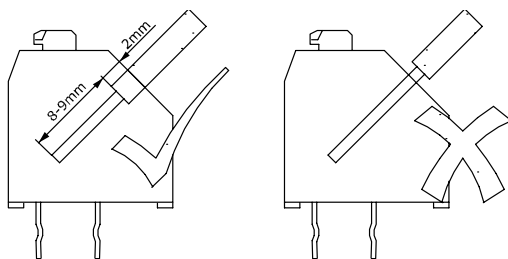

130BA177.10

Correct wire inserting



Do not combine liveparts and PELV systems.



Wires between X31/9 and Terminal 37 have to be short-circuit protected if not inside the cabinet.

Danfoss can accept no responsibility for possible errors in catalogues, brochures and other printed material. Danfoss reserves the right to alter its products without notice. This also applies to products already on order provided that such alterations can be made without subsequential changes being necessary in specifications already agreed. All trademarks in this material are property of the respective companies. Danfoss and the Danfoss logotype are trademarks of Danfoss A/S. All rights reserved.

