

Vickers® by Danfoss

## Flange Valves



### Flange Mounted Pressure Controls

Relief, Unloading & Check Valves -  
06, 08, 10 & 12 Size



# Flange Mounted Valves

Continued on next page

Model/Size: Relief Valves	Function	Max. Pressure	Max. Flow	Pressure Drop Ventcd at Max. Flow	P to T	Page	
CPF1S-06 SAE 3/4"	Relief, single pressure	275 bar (4000 psi)	100 l/min (26 USgpm)	-		6	
CPF1S-08 SAE 1"			300 l/min (80 USgpm)			11	
CPF1S-10 SAE 1 1/4"			600 l/min (160 US gpm)			12	
CPF1S-12 SAE 1 1/2"						13	
CPF1V-12 (code 62) SAE 1 1/2"		350 bar (5000 psi)	14				
CPF2S-06 SAE 3/4"	Relief, single pressure with vent	275 bar (4000 psi)	100 l/min (26 USgpm)	3,5 bar (51 psi) @ 100 l/min (26,4 USgpm)		15	
CPF2S-08 SAE 1"			300 l/min (80 USgpm)	4 bar (58 psi) @ 300 l/min (80 USgpm)		20	
CPF2S-10 SAE 1 1/4"			600 l/min (160 USgpm)	Internal Drain 7 bar (102 psi) @ 600 l/min (160 USgpm)		External Drain 4,9 bar (71 psi) @ 600 l/min (160 USgpm)	21
CPF2S-12 SAE 1 1/2"		Internal Drain 7,5 bar (109 psi) @ 600 l/min (160 USgpm)		External Drain 2,5 bar (36 psi) @ 600 l/min (160 USgpm)		22	
CPF2V-12 (code 62) SAE 1 1/2"		350 bar (5000 psi)	23				
CPF3S-06 SAE 3/4"	Bi-pressure relief with max. press. override	275 bar (4000 psi)	100 l/min (26 USgpm)	3,5 bar (51 psi) @ 100 l/min (26,4 USgpm)		24	
CPF3S-08 SAE 1"			300 l/min (80 USgpm)	4 bar (58 psi) @ 300 l/min (80 USgpm)		29	
CPF3S-10 SAE 1 1/4"			600 l/min (160 USgpm)	Internal Drain 7 bar (102 psi) @ 600 l/min (160 USgpm)		External Drain 4,9 bar (71 psi) @ 600 l/min (160 USgpm)	30
CPF3S-12 SAE 1 1/2"				Internal Drain 7,5 bar (109 psi) @ 600 l/min (160 USgpm)		External Drain 2,5 bar (36 psi) @ 600 l/min (160 USgpm)	31
CPF3V-12 (code 62) SAE 1 1/2"		350 bar (5000 psi)	32				
CPF4S-06 SAE 3/4"	Tri-pressure relief with max. press. override	275 bar (4000 psi)	100 l/min (26 USgpm)	3,5 bar (51 psi) @ 100 l/min (26,4 USgpm)		29	
CPF4S-08 SAE 1"			300 l/min (80 USgpm)	4 bar (58 psi) @ 300 l/min (80 USgpm)		30	
CPF4S-10 SAE 1 1/4"			600 l/min (160 USgpm)	Internal Drain 7 bar (102 psi) @ 600 l/min (160 USgpm)		External Drain 4,9 bar (71 psi) @ 600 l/min (160 USgpm)	31
CPF4S-12 SAE 1 1/2"				Internal Drain 7,5 bar (109 psi) @ 600 l/min (160 USgpm)		External Drain 2,5 bar (36 psi) @ 600 l/min (160 USgpm)	32
CPF4V-12 (code 62) SAE 1 1/2"		350 bar (5000 psi)					

Continued on next page

Model/Size: Unloading Valves	Function	Max. Pressure	Max. Flow	P P to T in Unloaded Position		Page	
UPF1S-06 SAE 3/4"	Unloading without check	275 bar (4000 psi)	100 l/min (26 USgpm)	Internal Drain 3,5 bar (51 psi) @ 100 l/min (26,4 USgpm)	External Drain 2,5 bar (36 psi) @ 100 l/min (26,4 USgpm)	33	
UPF1S-C*-06 SAE 3/4"	Unloading with check					38	
UPF1S-08 SAE 1 "	Unloading without check					39	
UPF1S-C*-08 SAE 1 "	Unloading with check			300 l/min (80 USgpm)	3,5 bar (51 psi) @ 100 l/min (26,4 USgpm)		40
UPF1S-10 SAE 1 1/4"	Unloading without check			600 l/min (160 US gpm)	Internal Drain 7,5 bar (109 psi ) @ 600 l/min (160 USgpm)	External Drain 4,9 bar (71 psi ) @ 600 l/min (160 USgpm)	41
UPF1S-C*-10 SAE 1 1/4"	Unloading with check						42
UPF1S-12 SAE 1 1/2"	Unloading without check					43	
UPF1V-12 (code 62) SAE 1 1/2"	Unloading without check	350 bar (5000 psi)			Internal Drain 7,5 bar (109 psi) @ 600 l/min (160 U S gpm)	External Drain 3 bar (44 psi) @ 600 l/min (160 US gpm)	44
UPF1S-C*-12 SAE 1 1/2"	Unloading with check						45
UPF2S-06 SAE 3/4"	Unloading with vent without check	275 bar (4000 psi)	100 l/min (26 USgpm)		Internal Drain 3,5 bar (51 psi) @ 100 l/min (26,4 USgpm)	External Drain 2,5 bar (36 psi) @ 100 l/min (26,4 USgpm)	46
UPF2S-C*-06 SAE 3/4"	Unloading with vent and check					51	
UPF2S-08 SAE 1 "	Unloading with vent without check			300 l/min (80 USgpm)	3,5 bar (51 psi) @ 100 l/min (26,4 USgpm)		53
UPF2S-C*-08 SAE 1 "	Unloading with vent and check					54	
UPF2S-10 SAE 1 1/4"	Unloading with vent without check	275 bar (4000 psi),	600 l/min 160 US gpm)	Internal Drain 7,5 bar (109 psi) @ 600 l/min (160 USgpm)	External Drain 4,9 bar (71 psi) @ 600 l/min (160 USgpm)	55	
UPF2S-C*-10 SAE 1 1/4"	Unloading with vent and check						56
UPF2S-12 SAE 1 1/2"	Unloading with vent without check						57
UPF2V-12 (code 62) SAE 1 1/2"	Unloading with vent without check	350 bar (5000 psi)			Internal Drain 7,5 bar (109 psi) @ 600 l/min (160 US gpm)	External Drain 3 bar (44 psi) @ 600 l/min (160 US gpm)	
UPF2S-C*-12 SAE 1 1/2"	Unloading with vent and check	275 bar (4000 psi)					58

Model/Size: Check Valve	Function	Max. Pressure	Max. Flow	Pressure Drop	Page
DCPFS-08 SAE 1 "	Right Angle Check valve	275 bar (4000 psi)	114 l/min (30 USgpm)	13 bar (187 psi) @114 l/min (30 USgpm) - 3,4 bar (50 psi) cracking press. 9,4 bar (137 psi) @114 l/min (30 USgpm) - 0,3 bar (5 psi) cracking press.	59 62
DCPFS-10 SAE 1 1/4"			227 l/min (60 USgpm)	4,1 bar (60 psi) @227 l/min (60 USgpm) - 0,3 (5 psi) cracking press.	62
DCPFS-12 SAE 1 1/2"			378 l/min (100 USgpm)	8,6 bar (125 psi) @378 l/min (100 USgpm) - 0,3 (5 psi) cracking press.	62
DICPFS-06 SAE .75 "	In-line Check valve	350 bar (5000 psi)	120 l/min (32 USgpm)	1,4 bar (20 psi) @120 l/min (32 USgpm) - 0,3 bar (5 psi) cracking press. 2,4 bar (35 psi) @120 l/min (32 USgpm) - 1,7 bar (25 psi) cracking press.	60 62
DICPFS-08 SAE 1 "			300 l/min (80 USgpm)	3,4 bar (49 psi) @300 l/min (80 USgpm) - 0,3 bar (5 psi) cracking press. 3,4 bar (49 psi) @300 l/min (80 USgpm) - 1,7 bar (25 psi) cracking press.	62
DICPFS-10 SAE 1 1/4"		280 bar (4000 psi)	600 l/min (160 USgpm)	8,3 bar (120 psi) @600 l/min (160 USgpm) - 0,3 bar (5 psi) cracking press. 8,3 bar (120 psi) @600 l/min (160 USgpm) - 1,7 bar (25 psi) cracking press.	62
DICPFS-12 SAE 1 1/2"		207 bar (3000 psi)	750 l/min (200 USgpm)	4,1 bar (60 psi) @750 l/min (200 USgpm) - 0,3 (5 psi) cracking press. 5,9 bar (85 psi) @750 l/min (200 USgpm) - 1,7 bar (25 psi) cracking press.	62

# Introduction

## Flange Mounted Valve Benefits

- Direct mounting to pump flange reduces potential leak points for superior leak resistance.
- Reduced installed costs and space requirements.
- Excellent repeatability and stable performance from cartridge design main stage parts.
- High response due to small trapped volume.
- Easier installation and servicing of components.
- Pilot design minimizes response time and cracking flow which allows for high pressure stability thus increasing system productivity.
- Fast opening and closing action and stable performance from cartridge design.
- Minimum unloaded pressure drop due to short piping runs.
- Viton seals provide multi-fluid capability without the need to change seals.

### Sizes

- 06 – 3/4" flange
- 08 – 1" flange
- 10 – 1 1/4" flange
- 12 – 1 1/2" flange

## General Description

### Relief Valves

Vickers by Danfoss space saving CPF relief valves improve machine reliability and uptime by limiting the pressure in a hydraulic circuit to the desired maximum, thereby protecting the hydraulic pump and system from pressure peaks. The CPF relief valves are designed to mount on a wide range of SAE pump outlet port flanges to eliminate intervalve piping and fittings.

Direct pump flange mounting of the valves reduces installation costs and provides a highly leak –resistant, compact pump control package.

CPF relief valves are of two –stage design with a fast –acting poppet type main stage for simple, long-lasting and effective operation. The pilot stage features a sensitive adjustment mechanism which allows setting of the pressure in fine increments over a wide range – up to the maximum rating of the valve.

The pressure setting adjustment choices available for the CPF relief valves are the standard screw-type adjuster with locknut, an optional knurled hand knob with set screw lock or a micrometer knob with or without keylock. External remote control/vent connections are available on all models. Additional optional features include various pressure setting ranges and many solenoid valve options on valves so equipped.

These CPF relief valves have excellent dynamic and steady state operating characteristics including stability, fast response and low pressure override. The many available control options make it possible to choose the optimum valve model for industrial and mobile applications. Additionally, CPF valves use many of the same parts of other Vickers by Danfoss products to insure proven durability. For over 70 years, the Vickers name has been synonymous with long, trouble-free service.

### Unloading Valves

Unloading valves are used in accumulator charging circuits where a pressure regulator is required to automatically unload the pump. This is done by diverting the pump delivery to the reservoir at low pressure when the desired accumulator pressure is reached. Also, the UPF unloading valve can be used to unload the low pressure side of a double pump.

The UPF unloading valves are designed to mount directly on SAE pump outlet port flanges to eliminate intervalve piping and fittings. Direct pump flange mounting of the valves reduces installation costs and provides a highly leak resistant, compact pump control package.

UPF unloading valves are of two-stage design with a fast acting poppet type main stage for simple, long-lasting, and effective operation. The pilot stage features a sensitive adjustment mechanism which allows setting of the pressure in fine increments over a wide range – up to the maximum rating of the valve.

The pressure setting adjustment choices available for the UPF unloading valves are the standard screw-type adjuster with locknut or optional adjusters with or without keylock. Gage connections for pump and system pressures are available on all models. Additional optional features include various pressure setting ranges and many solenoid valve options on valves so equipped.

Unloading valves may be ordered with or without the integral check valve.

### Check Valves

DCPF/DICPF flange mounted right angle and in-line check valves are ruggedly designed for superior shock resistance, reliability and long life.

The check valves may be mounted directly on an SAE pump outlet port flange or may be stacked with a CPF relief valve to provide a pump unloading function. The DCPF/DICPF check valves are not intended for use as an unloading check.

The right angle and in-line check valves are offered in sizes matching the CPF relief valves.

# CPF1\*-06/08/10/12-\*\*-20

## Relief Valve Without Venting

### Flange Sizes

- 06 - 3/4 inch flange
- 08 - 1 inch flange
- 10 - 1 1/4 inch flange
- 12 - 1 1/2 inch flange

### Benefits

- Direct mounting to pump flange reduces potential leak points for superior leak resistance.
- Reduced installed costs and space requirements.
- Excellent repeatability and stable performance from cartridge design mainstage parts.
- Easier installation and servicing of components (stackable design).
- Pilot design minimizes response time and cracking flow which allows for high pressure stability thus increasing system productivity.

Ratings	CPF1S-06	CPF1S-08	CPF1S-10	CPF1S-12
Maximum flow	100 l/min (26 USgpm)	300 l/min (80 USgpm)	600 l/min (160 USgpm)	600 l/min (160 USgpm)
Maximum pressure:				
P port	275 bar (4000 psi)	275 bar (4000 psi)	275 bar (4000 psi)	275 bar (4000 psi)*
T port	207 bar (3000 psi)	207 bar (3000 psi)	207 bar (3000 psi)	207 bar (3000 psi)

\* The CPF1V-12 (code 62 flange) has a P port max. pressure rating of 350 bar (5000 psi).

### Hydraulic Response

06 Size: Rate of pressure rise with 2,5 liters (.7 USgpm) of oil under compression = 3450 bar (50000 psi) /second. Maximum overshoot < 8%.

08 Size: Rate of pressure rise with 2,5 liters (.7 USgpm) of oil under compression = 2900 bar (42000 psi) /second. Maximum overshoot < 10%.

10/12 Sizes: Rate of pressure rise with 2,5 liters (.7 USgpm) of oil under compression = 2600 bar (37500 psi) /second. Maximum overshoot < 10%.

### General Description

This Vickers by Danfoss CPF1S relief valve features flange mounting for increased design flexibility and reduced external piping. The valve is designed for direct mounting on the SAE flange outlet port of a pump. Fewer leak points and SAE flange connections lead to installations with superior leak resistance.

Pressure relief valves are used to limit or control pressure by directing system flow to the reservoir when system pressure reaches the setting of the valve. System overload is thereby prevented and peak pressures which

could damage the pump and actuating components are eliminated.

The CPF1S valve has excellent dynamic and steady state operating characteristics including stability, fast response and low pressure override. CPF relief valves are of two –stage design with a fast –acting poppet type main stage for simple, long –lasting and effective operation. The many available control options make it possible to choose the optimum valve model for each application.

# CPF1\* Model Series

## Model Code

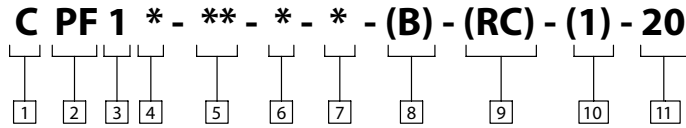

<p><b>1</b> Valve Function</p> <p>C - Relief</p>	<p><b>5</b> Valve Size</p> <p>06 - 3/4 inch              08 - 1 inch              10 - 1 1/4 inch              12 - 1 1/2 inch</p>	<p><b>8</b> Thread Type              (remote control/vent connection)</p> <p>Blank - SAE-6 O-ring boss port              (.5625-18 UNF-2B thd.)              B - BSP-G 1/4 (1/4" BSPF)</p>
<p><b>2</b> Mounting Type</p> <p>PF - Pump flange mounting</p>	<p><b>6</b> Pressure Range</p> <p>A - 10 - 50 bar (145 - 725 psi)              B - 10 - 100 bar (145 - 1450 psi)              F - 10 - 207 bar (145 - 3000 psi)              G - 10 - 275 bar (145 - 4000 psi)              350 bar (5000 psi) - (CPF*V-12 models only)</p>	<p><b>9</b> Remote Control</p> <p>Blank - No remote control              RC - Remote Control</p>
<p><b>3</b> Unit Type</p> <p>1 - Single pressure without vent</p>	<p><b>7</b> Control Type</p> <p>W - Screw adjust with locknut              H - Handknob adjust without keylock              K - Micrometer adjust with keylock</p>	<p><b>10</b> Pilot Drain</p> <p>Blank - Internal drain              1 - External drain</p>
<p><b>4</b> Flange Type</p> <p>S - SAE J518 4-bolt flange standard series code 61 (available in all sizes)              V - SAE J518 4-bolt high pressure series code 62 (size 12 only)</p>		<p><b>11</b> Design Number, 20 Series</p> <p>Subject to change. Installation dimensions unaltered for design numbers 20 to 29 inclusive.</p>

# Circuit Schematics

CPF15-06/08-\* -20 with remote control

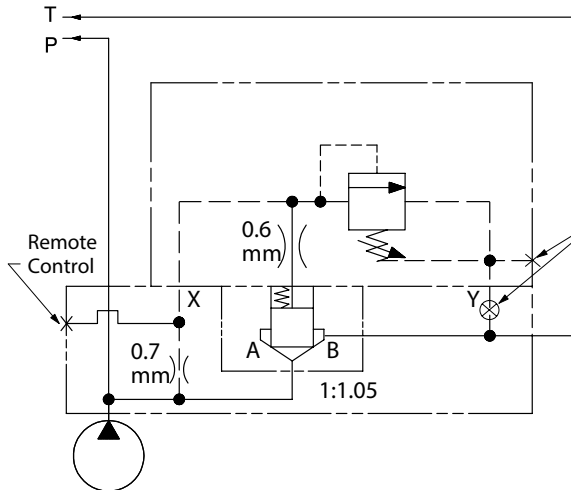

-06 size 100 l/min (26 USgpm) max. flow  
 -08 size 300 l/min (80 USgpm) max. flow

CPF15-06/08-P-\* -20 without remote control

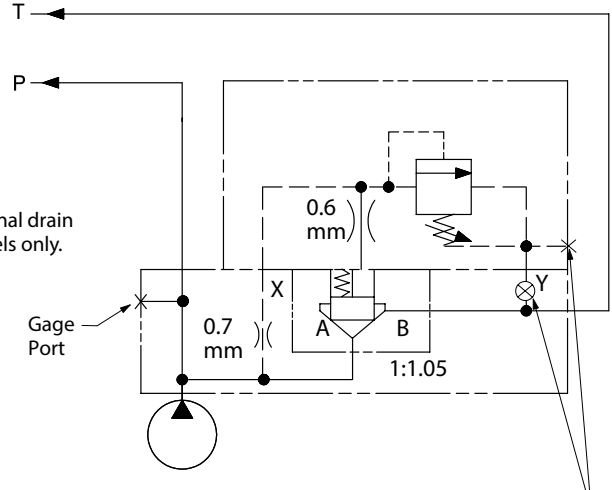

-06 size 100 l/min (26 USgpm) max. flow  
 -08 size 300 l/min (80 USgpm) max. flow

External drain models only.

CPF15-10/12-\* -20 with remote control

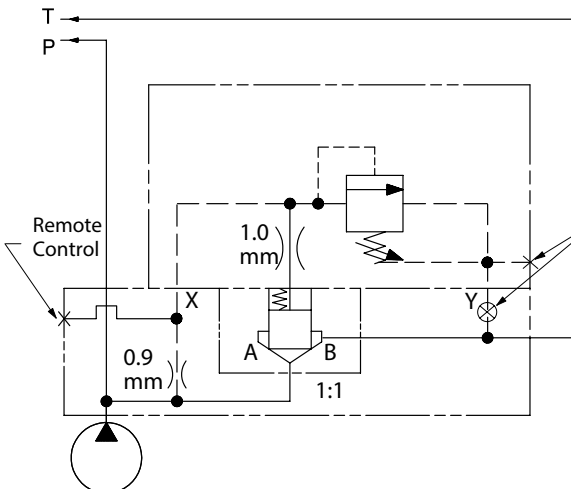

-10/-12 size 600 l/min (160 USgpm) max. flow

CPF15-10/12-P-\* -20 without remote control

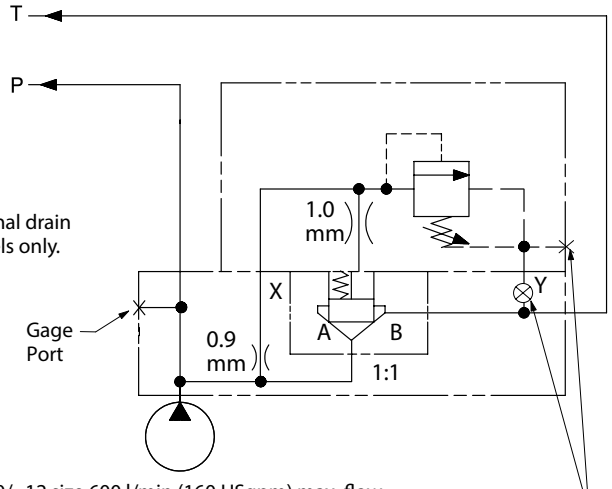

-10/-12 size 600 l/min (160 USgpm) max. flow

External drain models only.



# Pressure Curves

CPF1S-06

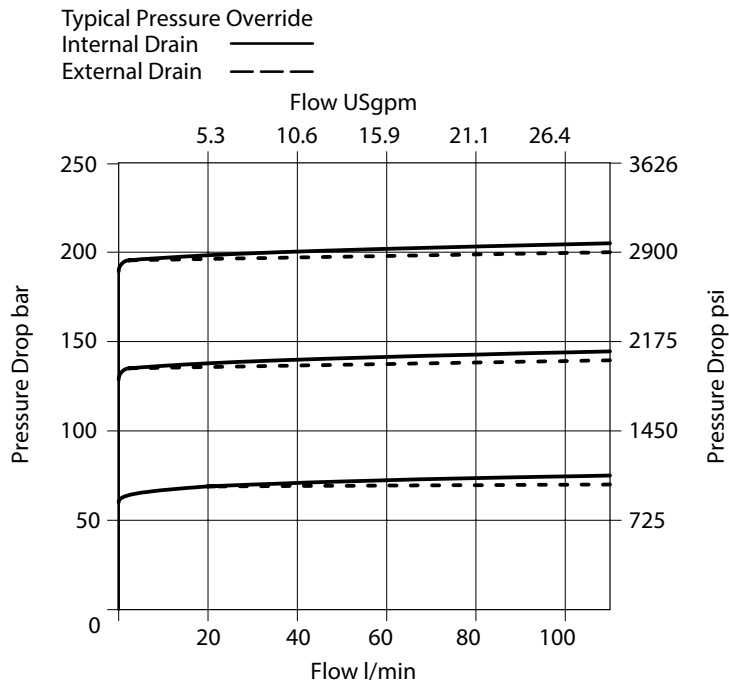

CPF1S-08

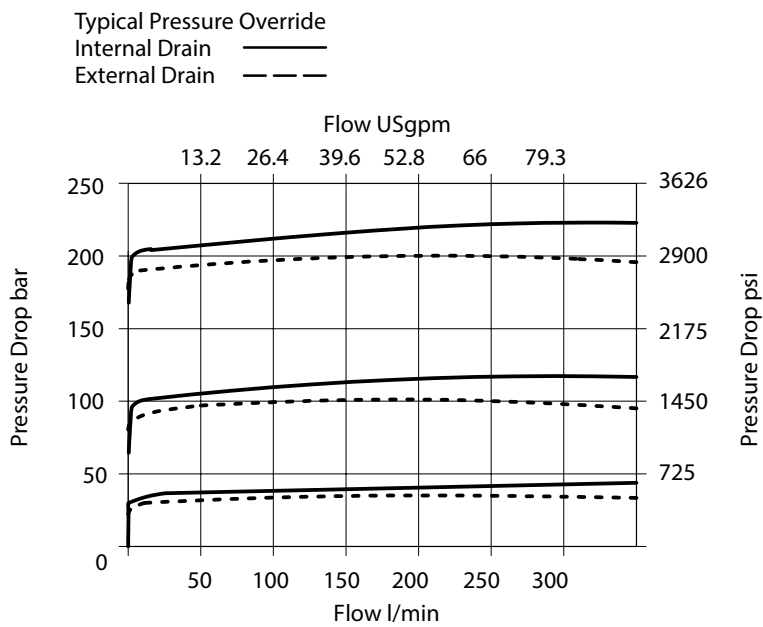

CPF1S-10

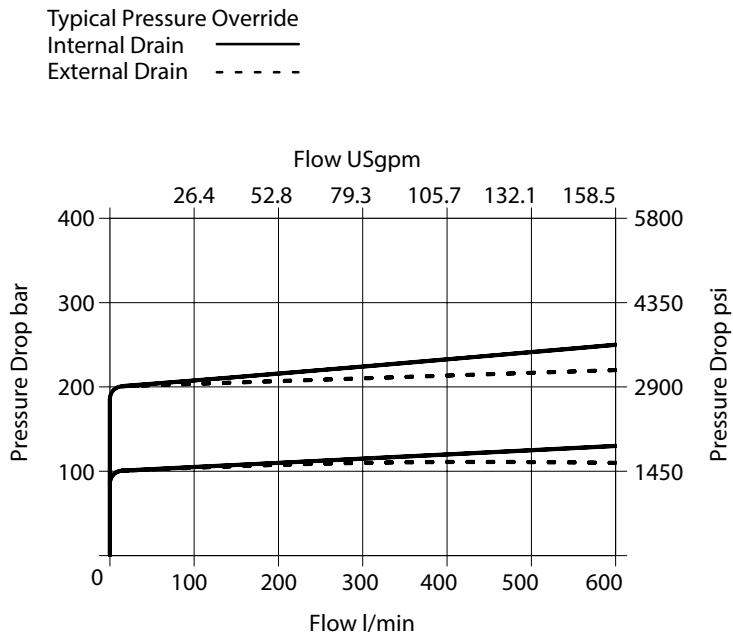

CPF1S-12  
CPF1V-12

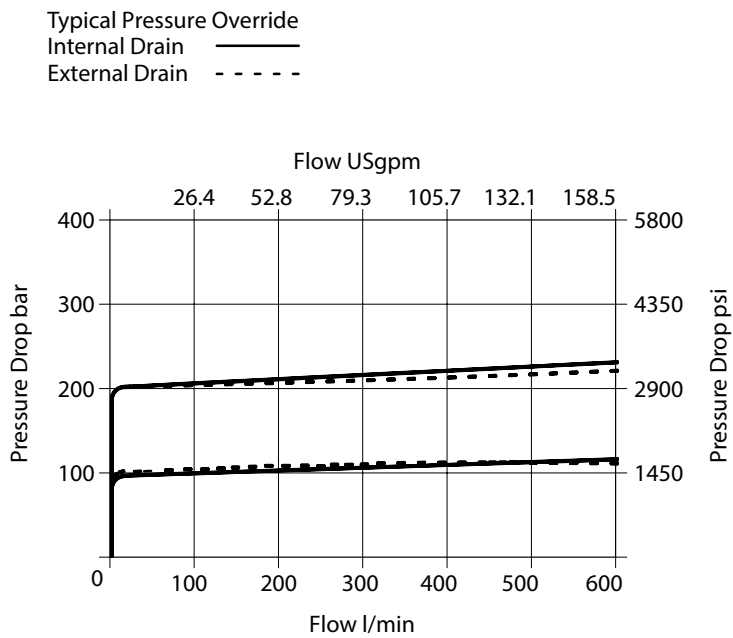

# Installation Dimensions

## CPF1S-06 3/4" Flange - Single Pressure Relief Valve without Vent

mm (inch)

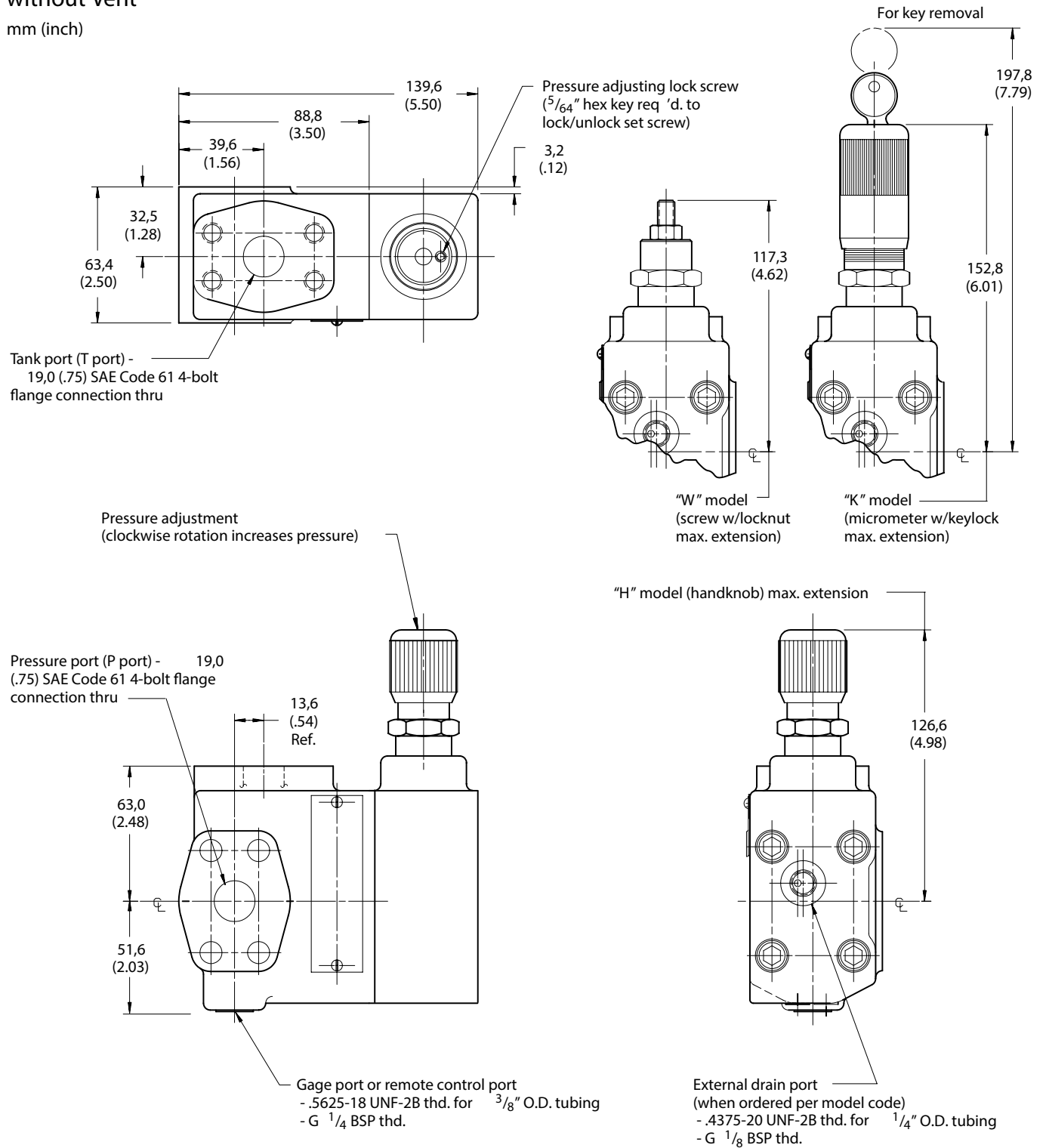

# CPF1S-08 1 " Flange - Single Pressure Relief Valve without Vent

mm (inch)

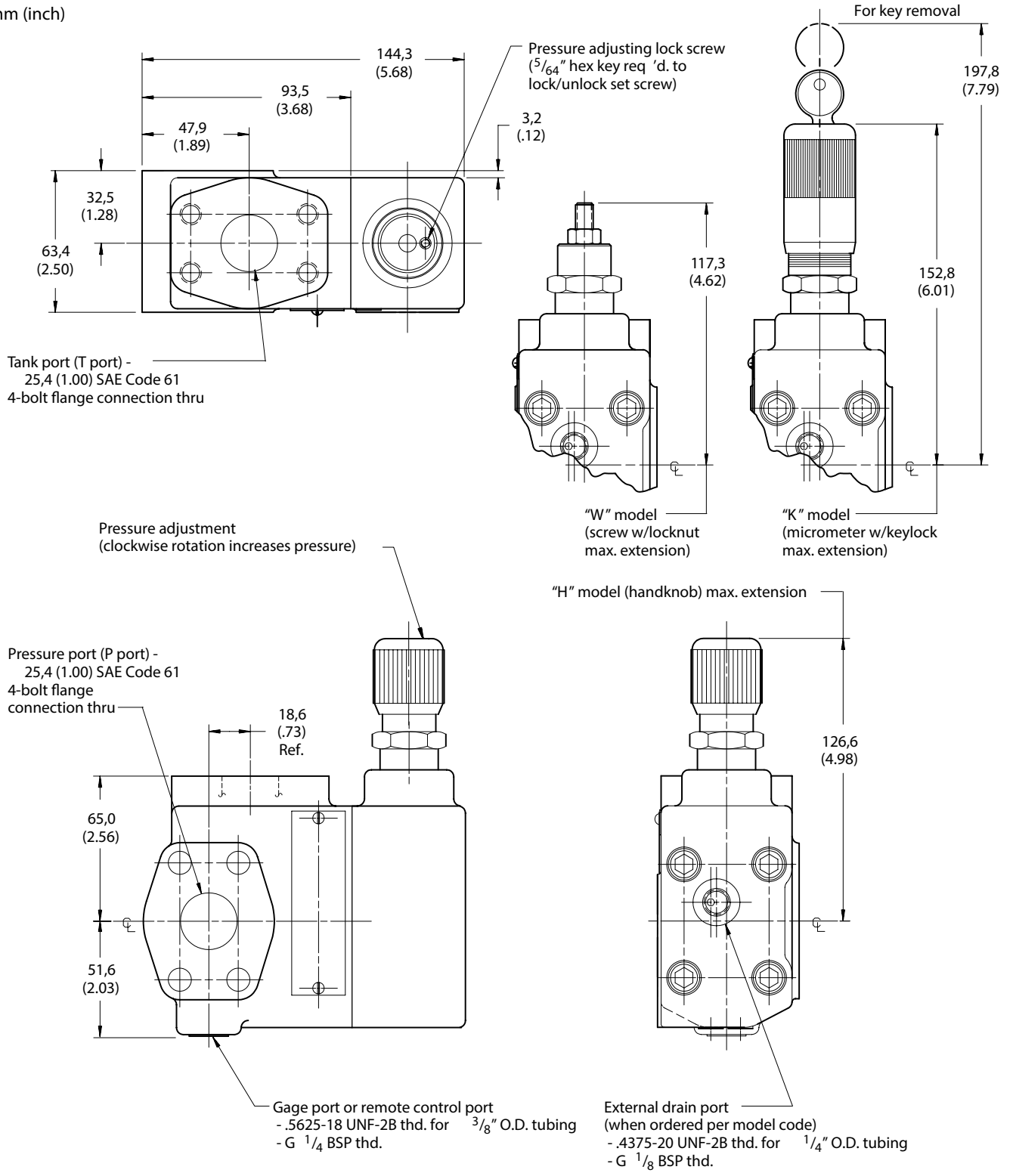

# CPF1S-10 1 1/4" Flange - Single Pressure Relief Valve Without Vent

mm (inch)

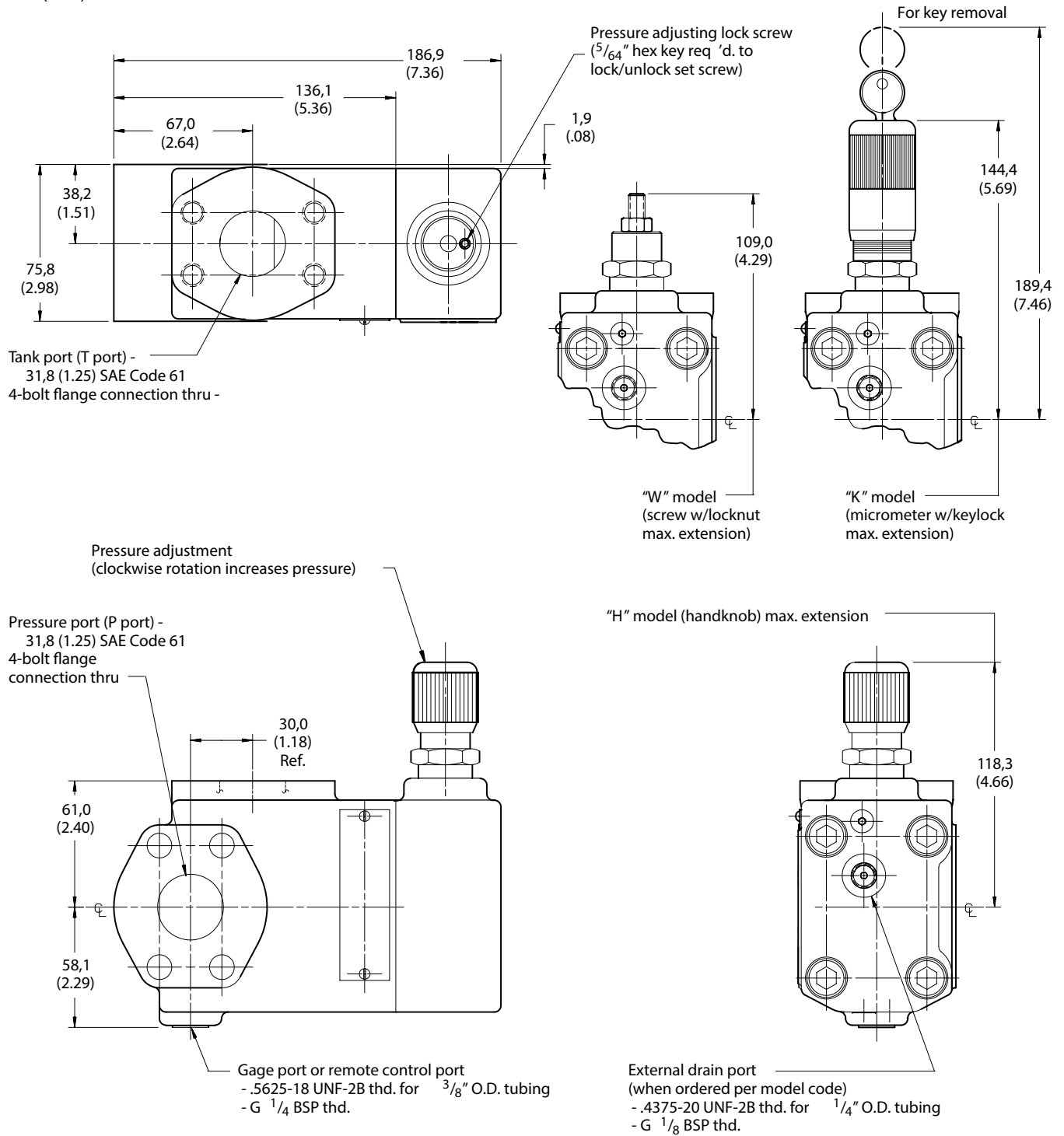

CPF1S-12 – Code 61  
 CPF1V-12 – Code 62  
 1½" Flange -  
 Single Pressure Relief Valve  
 Without Vent

mm (inch)

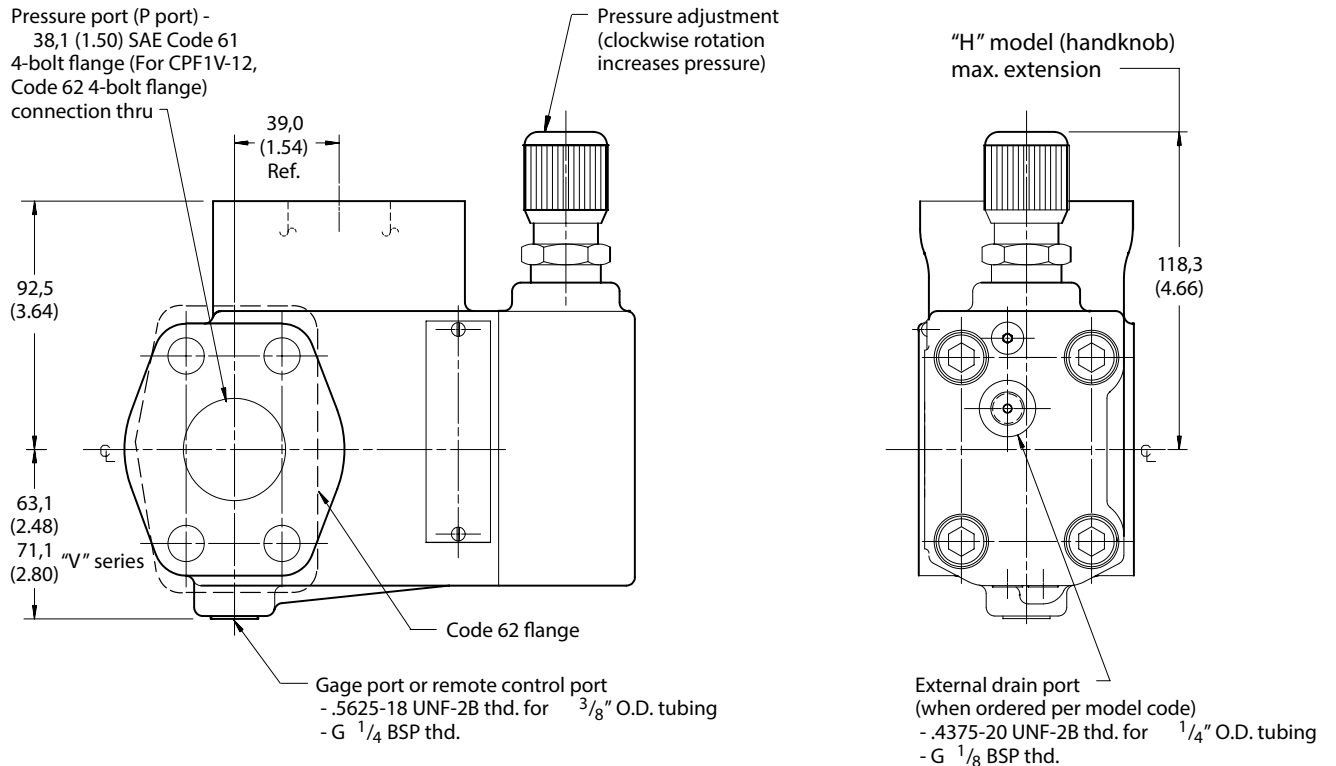
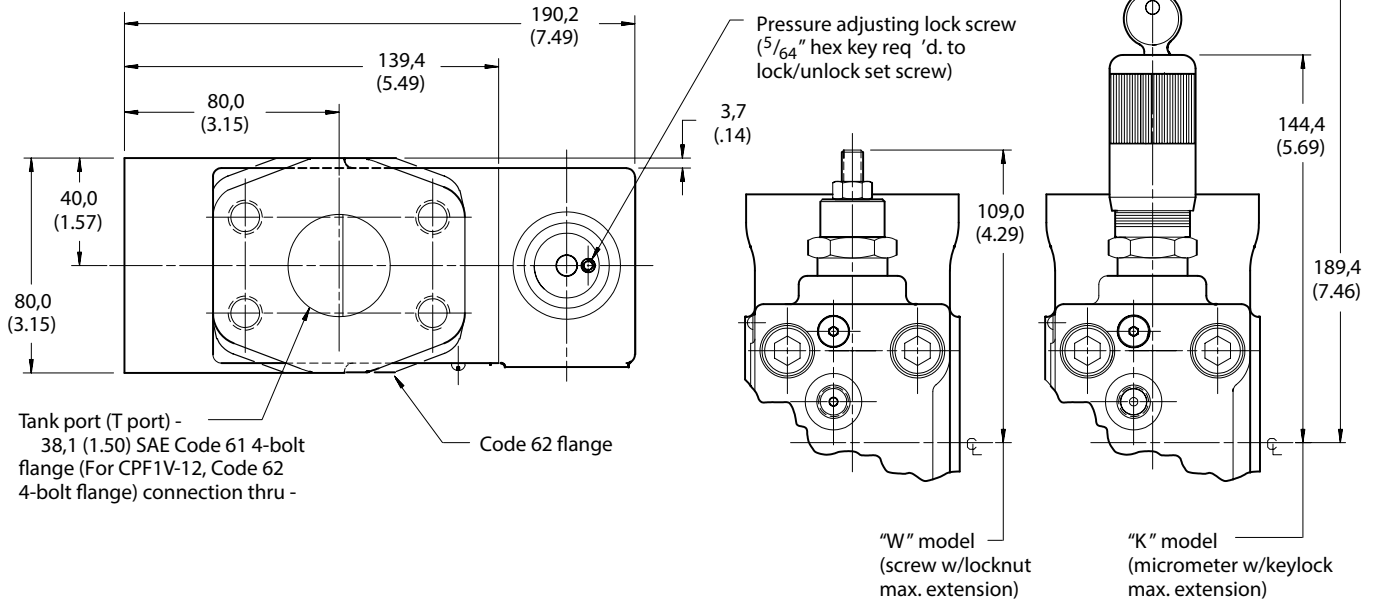

# CPF2\*-06/08/10/12-\*\*-20

## Relief Valve with Venting

### Flange Sizes

- 06 - 3/4 inch flange
- 08 - 1 inch flange
- 10 - 1 1/4 inch flange
- 12 - 1 1/2 inch flange

### Benefits

- Excellent repeatability and stable performance from cartridge design mainstage parts.
- Reduced installed costs and space requirements.
- Easier installation and servicing of components.
- Pilot design minimizes response time and cracking flow which allows for high pressure stability thus increasing system productivity.
- Direct mounting to pump flange reduces potential leak points for superior leak resistance.

Ratings	CPF2S-06	CPF2S-08	CPF2S-10	CPF2S-12
Maximum flow	100 l/min (26 USgpm)	300 l/min (80 USgpm)	600 l/min (160 USgpm)	600 l/min (160 USgpm)
Maximum pressure:				
P port	275 bar (4000 psi)	275 bar (4000 psi)	275 bar (4000 psi)	275 bar (4000 psi)*
T port	207 bar (3000 psi)	207 bar (3000 psi)	207 bar (3000 psi)	207 bar (3000 psi)

\* The CPF2V-12 (code 62 flange) has a max. P port pressure rating of 350 bar (5000 psi).

### Pilot Valve Max. T Port Pressure Rating

100 bar (1450 psi) for DG4V-3S valve  
 210 bar (3045 psi) for DG4V-3 valve AC  
 210 bar (3045 psi) for DG4V-3 valve DC

### Electrical Response

Electrical response is defined as the time from initiation of power to the solenoid, to the initiation of pressure rise, with 1,5 liters (.4 USgpm) of oil under compression:

06 size –  
 @100 l/min (26 USgpm) = DC - 200 ms  
 AC - 160 ms  
 08 size –  
 @300 l/min (80 USgpm) = DC - 210 ms  
 AC - 175 ms  
 10/12 size -  
 @300 l/min (80 USgpm) = DC - 180 ms  
 AC - 160 ms

### Hydraulic Response

06 Size: Rate of pressure rise with 2,5 liters (.7 USgpm) of oil under compression = 3450 bar (50000 psi) /second. Maximum overshoot < 8%.

08 Size: Rate of pressure rise with 2,5 liters (.7 USgpm) of oil under compression = 2900 bar (42000 psi) /second. Maximum overshoot < 10%.

10/12 Sizes: Rate of pressure rise with 2,5 liters (.7 USgpm) of oil under compression = 2600 bar (37500 psi) /second. Maximum overshoot < 10%.

### General Description

This Vickers by Danfoss CPF2S relief valve features flange mounting for increased design flexibility and reduced external piping. The valve is designed for direct mounting on the SAE flange outlet port of a pump. Fewer leak points and SAE flange connections lead to installations with superior leak resistance.

Pressure relief valves are used to limit or control pressure by directing system flow to the reservoir when system pressure reaches the setting of the

valve. System overload is thereby prevented and peak pressures which could damage the pump and actuating components are eliminated.

The CPF2S relief valves also provide a means of limiting system pressure to the relatively low vented pressure by directing pilot flow to tank by de-energizing the solenoid operated DG4V –3 valve.

The CPF2S valve has excellent dynamic and steady state operating characteristics including stability, fast

response and low pressure override. CPF relief valves are of two –stage design with a fast –acting poppet type main stage for simple, long –lasting and effective operation. The many available control options make it possible to choose the optimum valve model for each application.

# CPF2\* Model Series

## Model Code

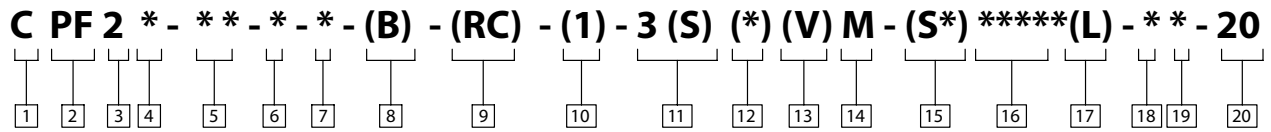

<p><b>1</b> Valve Function</p> <p>C - Relief</p>	<p><b>7</b> Control Type</p> <p>W - Screw adjust with locknut H - Handknob adjust without key K - Micrometer adjust with keylock</p>	<p><b>14</b> Electrical Options Flag</p>
<p><b>2</b> Mounting Type</p> <p>PF - Pump flange mounting</p>	<p><b>8</b> Thread Type (remote control/Vent connection)</p> <p>Blank - SAE-6 O-ring boss port (.5625-18 UNF-2B thd.) B - BSP-G 1/4 (1/4" BSPF)</p>	<p><b>15</b> Spool Position Monitoring Switch</p>
<p><b>3</b> Unit Type</p> <p>2 - Single pressure with vent</p>	<p><b>9</b> Remote Control</p> <p>Blank - No remote control RC - Remote control</p>	<p><b>16</b> Solenoid Type/Electrical Connections</p>
<p><b>4</b> Flange Type</p> <p>S - SAE J518 4-bolt flange standard series code 61 (available in all sizes) V - SAE J518 4-bolt high pressure series code 62 (size 12 only)</p>	<p><b>10</b> Pilot Drain</p> <p>Blank - Internal drain 1 - External drain</p>	<p><b>17</b> Indicator Lights</p>
<p><b>5</b> Valve Size</p> <p>06 - 3/4 inch 08 - 1 inch 10 - 1 1/4 inch 12 - 1 1/2 inch</p>	<p><b>11</b> Vent Valve</p> <p>3S - Standard performance 3 - High performance Uses OBL type spool/spring. Other features are optional. Refer to Vickers by Danfoss literature # GB-C-2015B Solenoid Operated Directional Control Valves catalog.</p>	<p><b>18</b> Coil Identification</p>
<p><b>6</b> Pressure Range</p> <p>A - 10 - 50 bar (145 - 725 psi) B - 10 - 100 bar (145 - 1450 psi) F - 10 - 207 bar (145 - 3000 psi) G - 10 - 275 bar (145 - 4000 psi) - 350 bar (5000 psi) - (CPF2V-12 models only)</p>	<p><b>12</b> Manual Override Options</p>	<p><b>19</b> Tank Rating Pressure</p> <p>2 - 10 bar (145 psi) for spool position indicator models. 5 - 100 bar (1450 psi) for standard performance models, DG4V-3S, with AC or DC solenoids. 6 - 207 bar (3000 psi) for high performance models, DG4V-3, with AC solenoids. 7 - 207 bar (3000 psi) for high performance models, DG4V-3 with DC solenoids.</p>
	<p><b>13</b> Solenoid Energization Identification</p>	<p><b>20</b> Design Number, 20 series</p> <p>Subject to change. Installation dimensions unaltered for design numbers 20 to 29 inclusive.</p> <p>EN417 - Normally closed, energize to vent relief</p>



# Circuit Schematics

CPF2S-06/08-\*-20

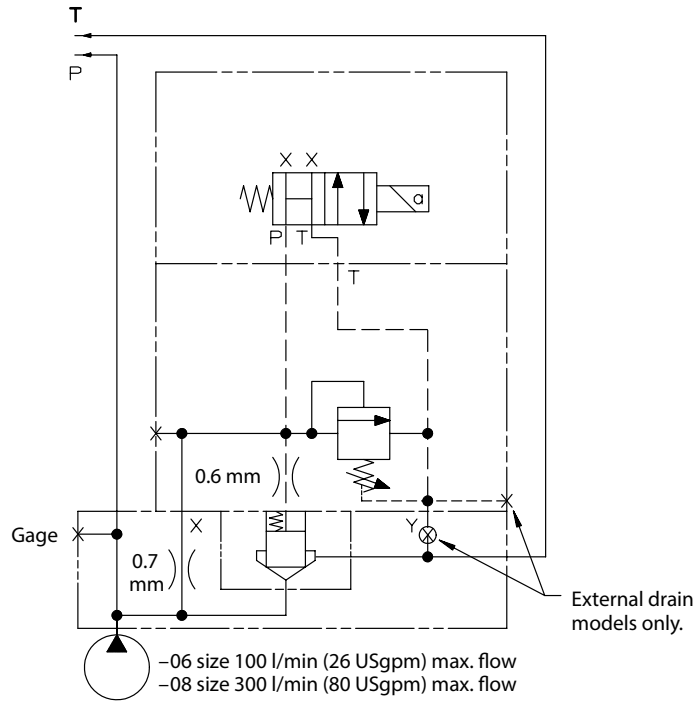

CPF2S-10/12-\*-20  
CPF2V-12-\*-20

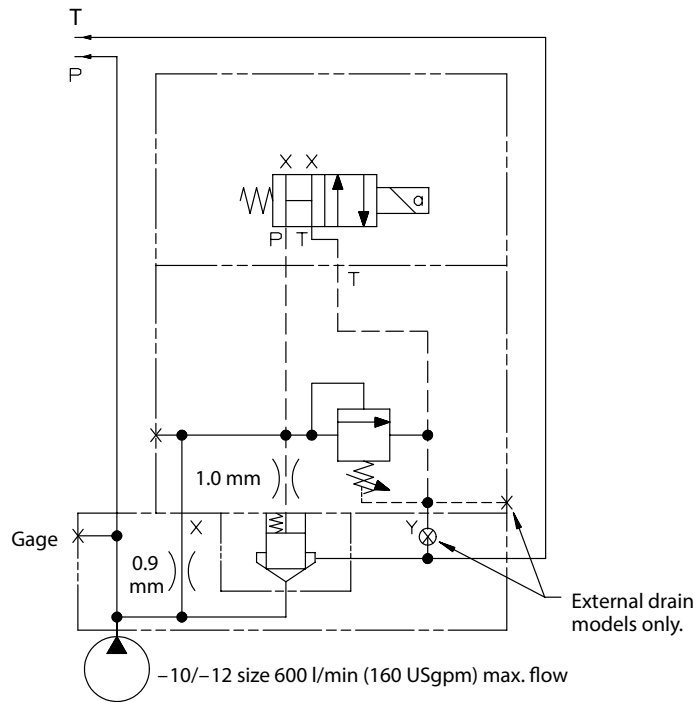

# Pressure Curves

CPF2S-06

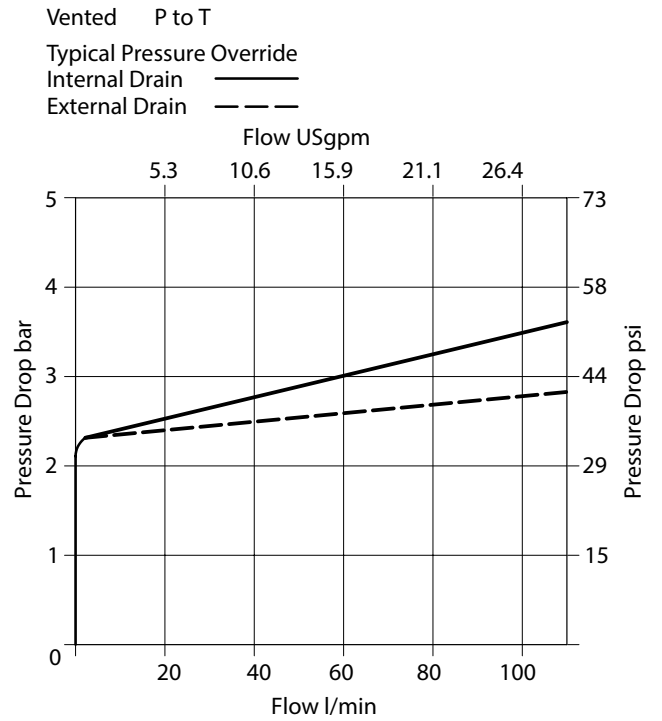
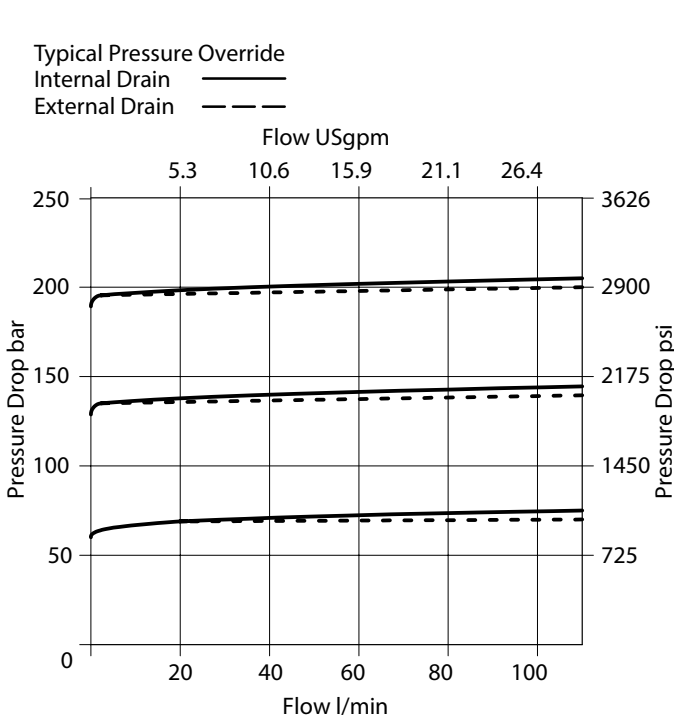

CPF2S-08

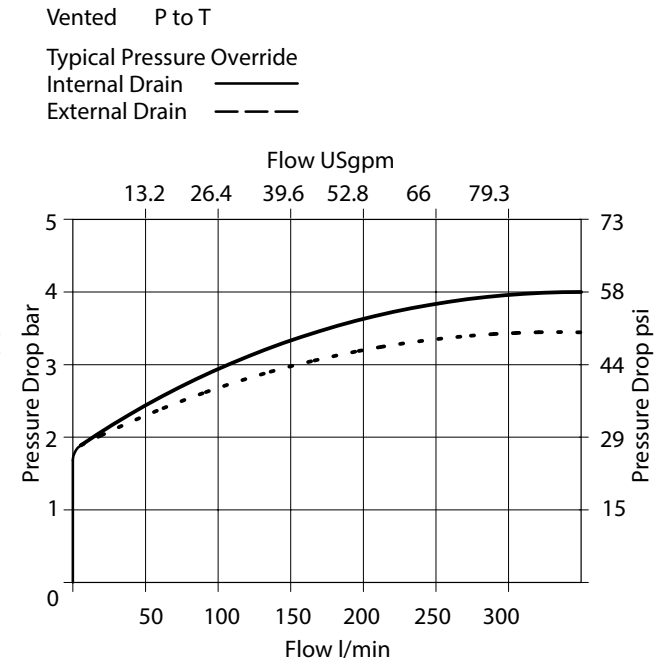
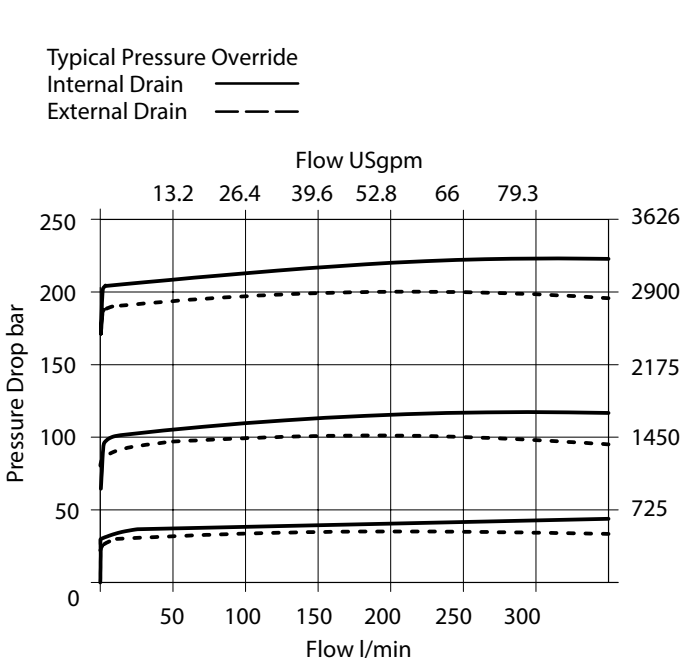

CPF2S-10

Typical Pressure Override  
 Internal Drain ———  
 External Drain - - - - -

Vented P to T  
 Internal Drain ———  
 External Drain - - - - -

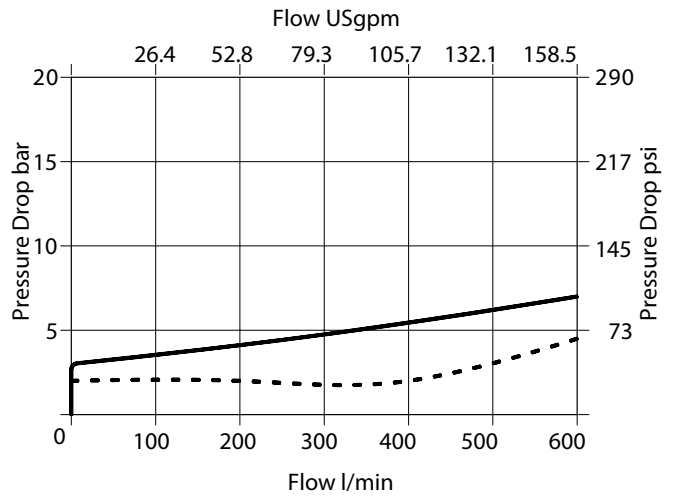
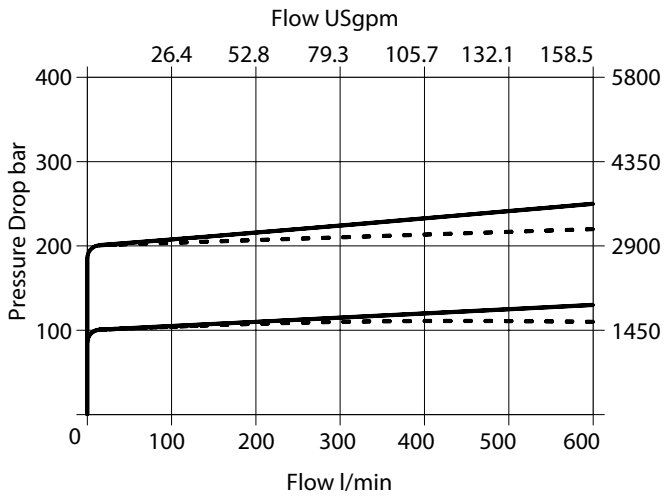

CPF2S-12  
 CPF2V-12

Typical Pressure Override  
 Internal Drain ———  
 External Drain - - - - -

Vented P to T  
 Internal Drain ———  
 External Drain - - - - -

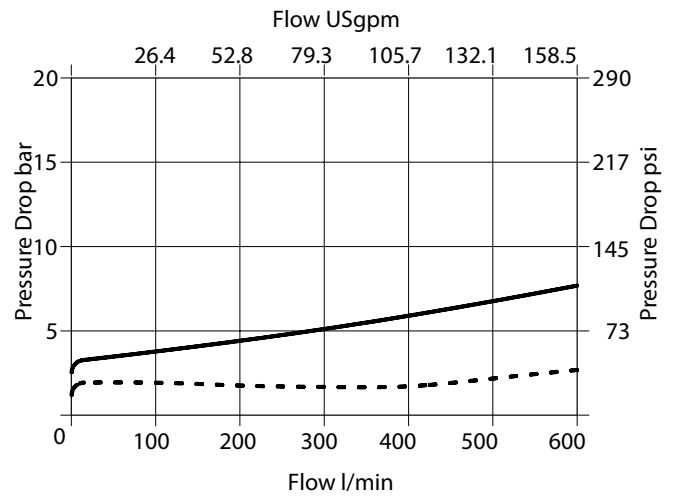
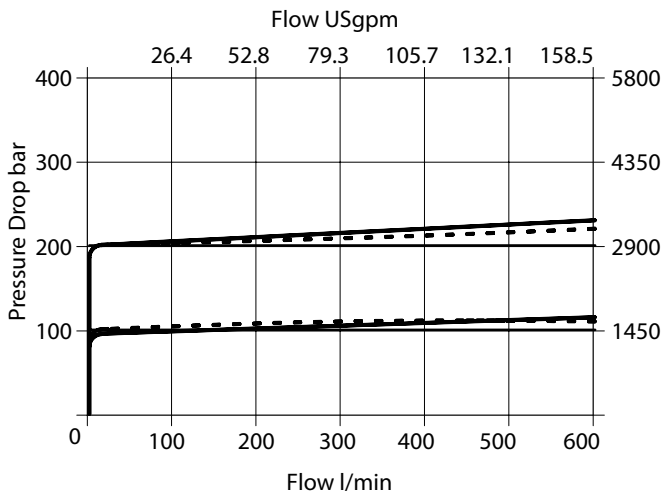

# Installation Dimensions

## CPF2S-06 3/4" Flange - Single Pressure Relief Valve With Vent

mm (inch)

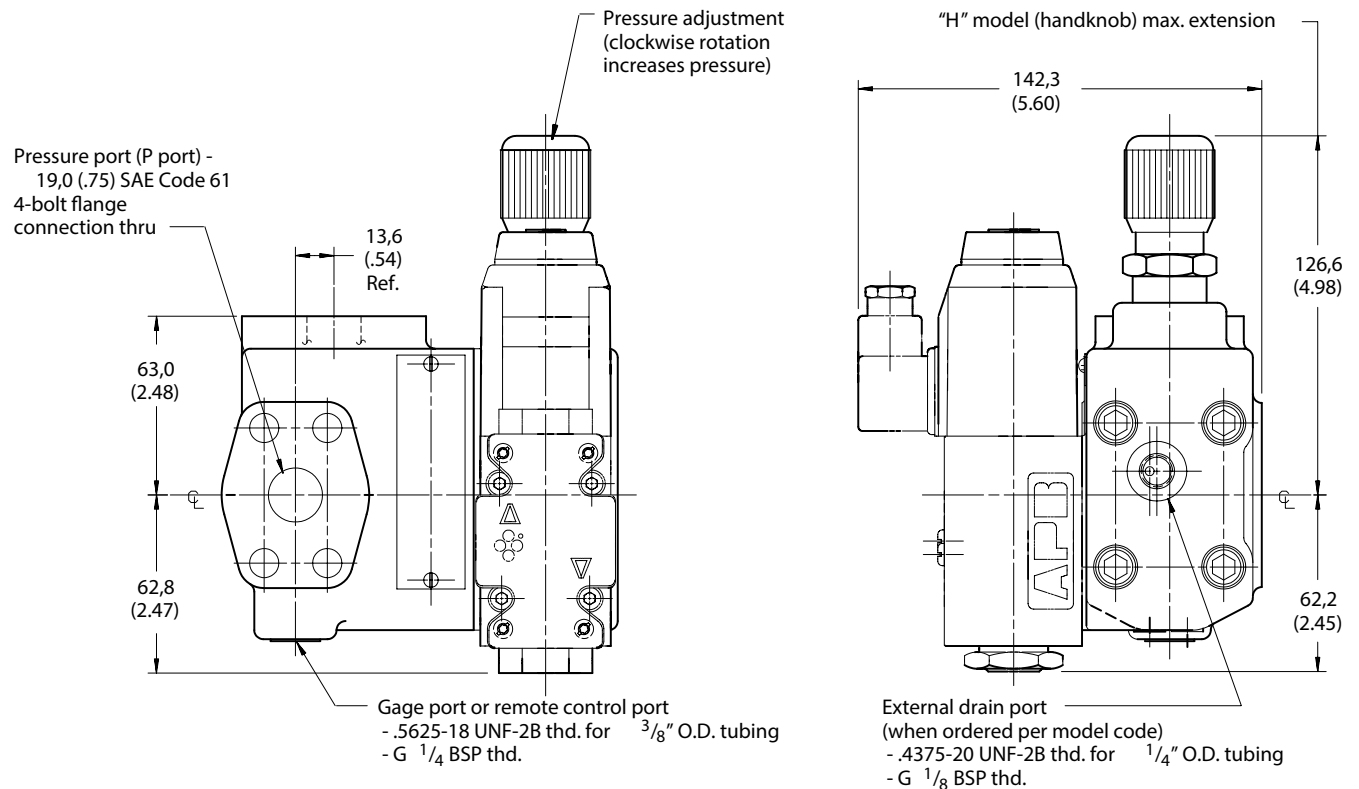
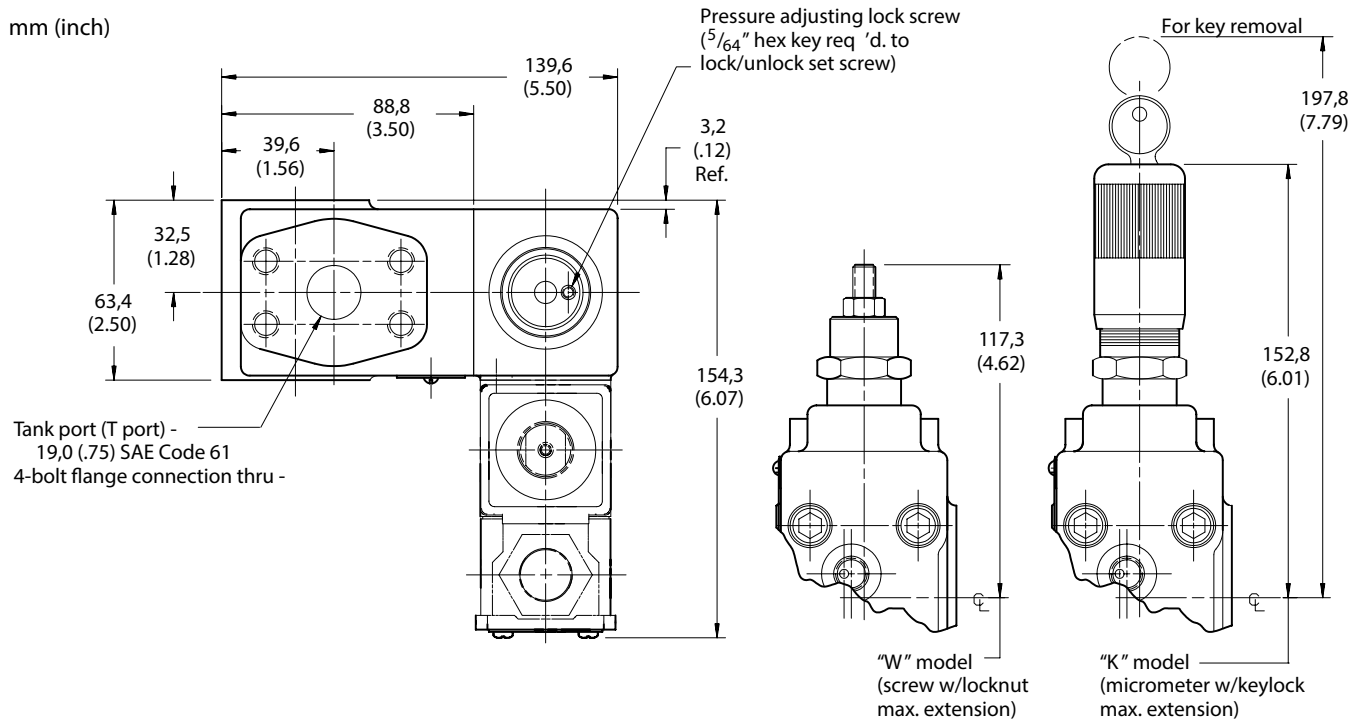

# CPF2S-08 1 " Flange - Single Pressure Relief Valve With Vent

mm (inch)

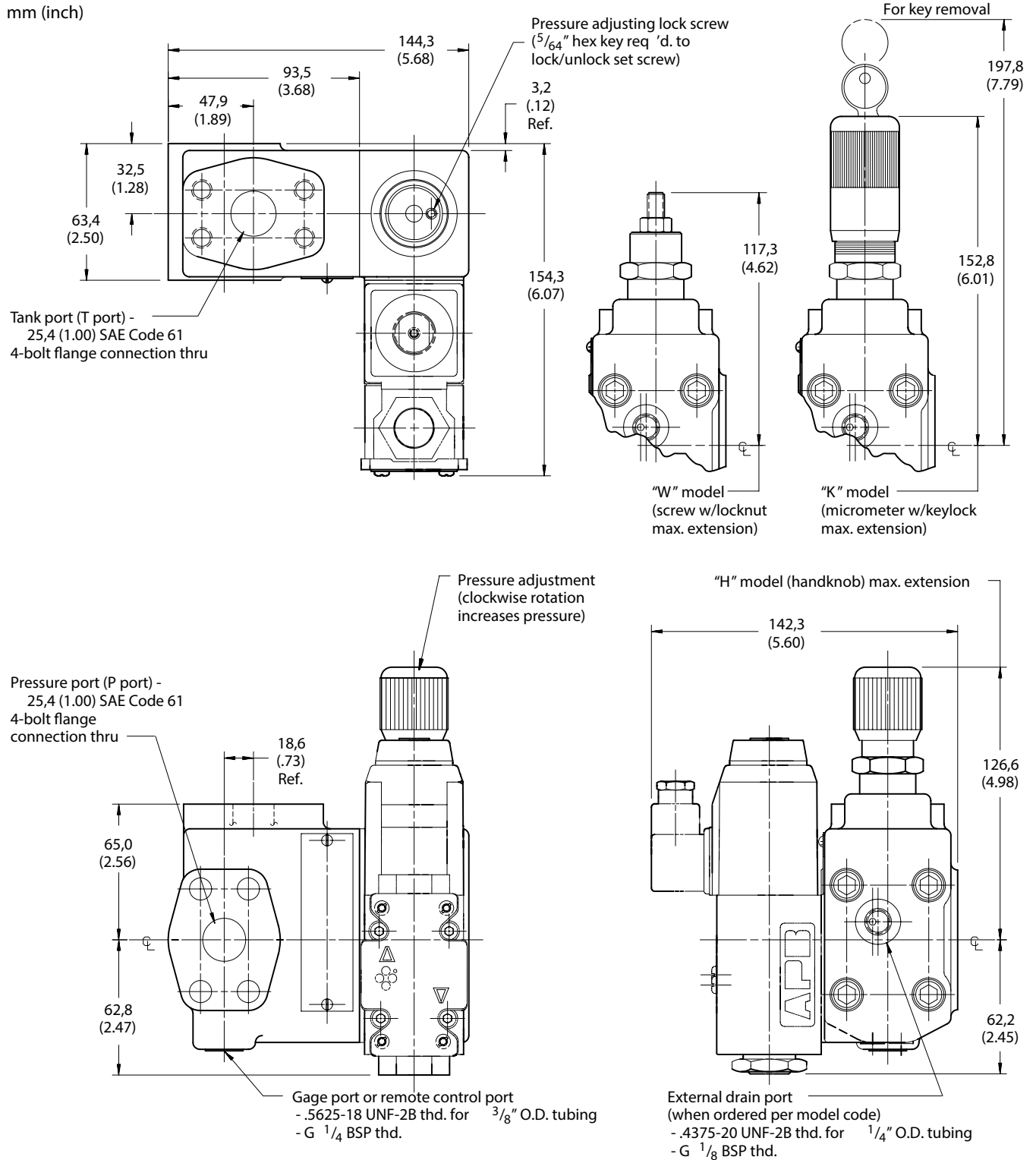

# CPF2S-10 1 1/4" Flange - Single Pressure Relief Valve With Vent

mm (inch)

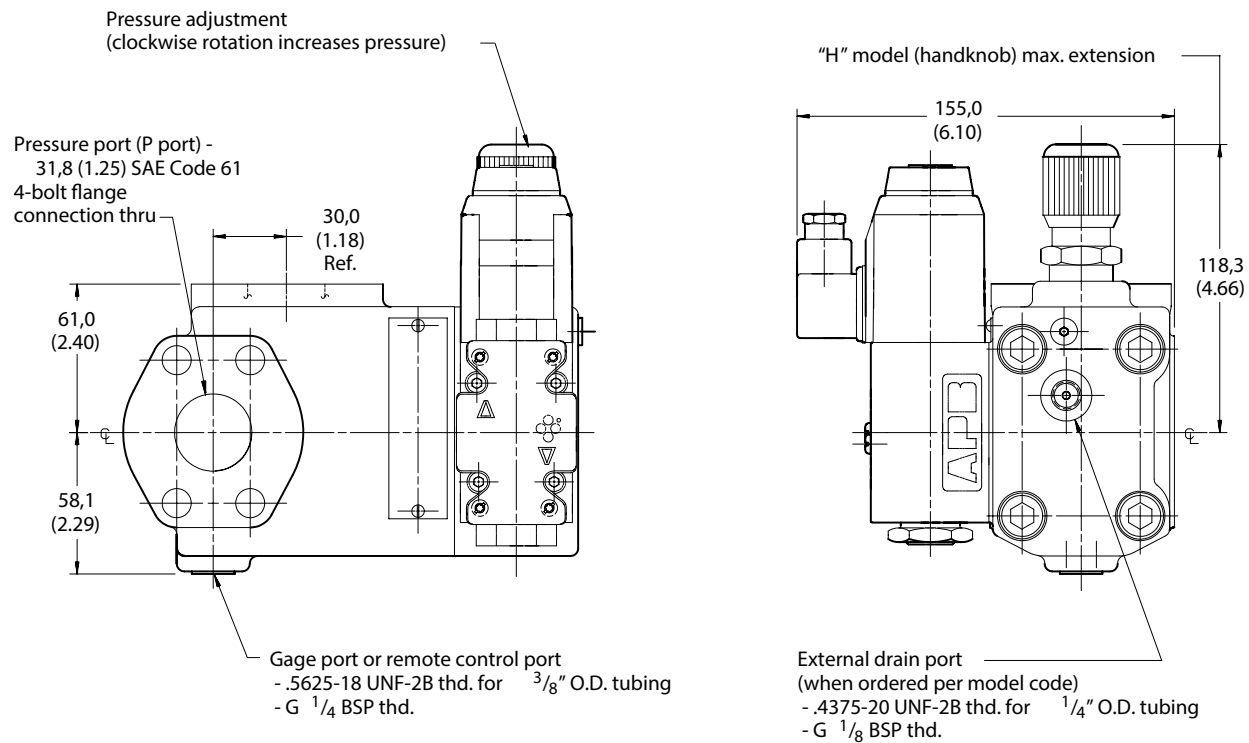
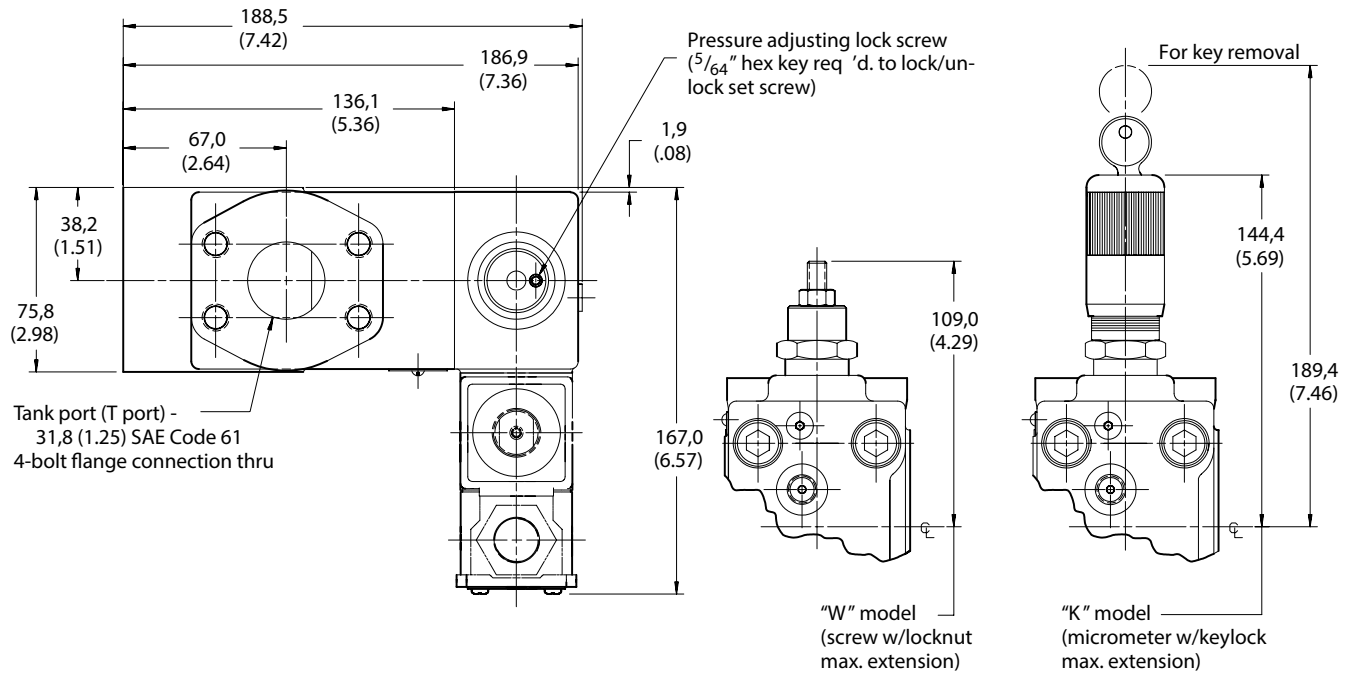

CPF2S-12 - Code 61  
 CPF2V-12 - Code 62  
 1 1/2" Flange -  
 Single Pressure Relief Valve  
 With Vent

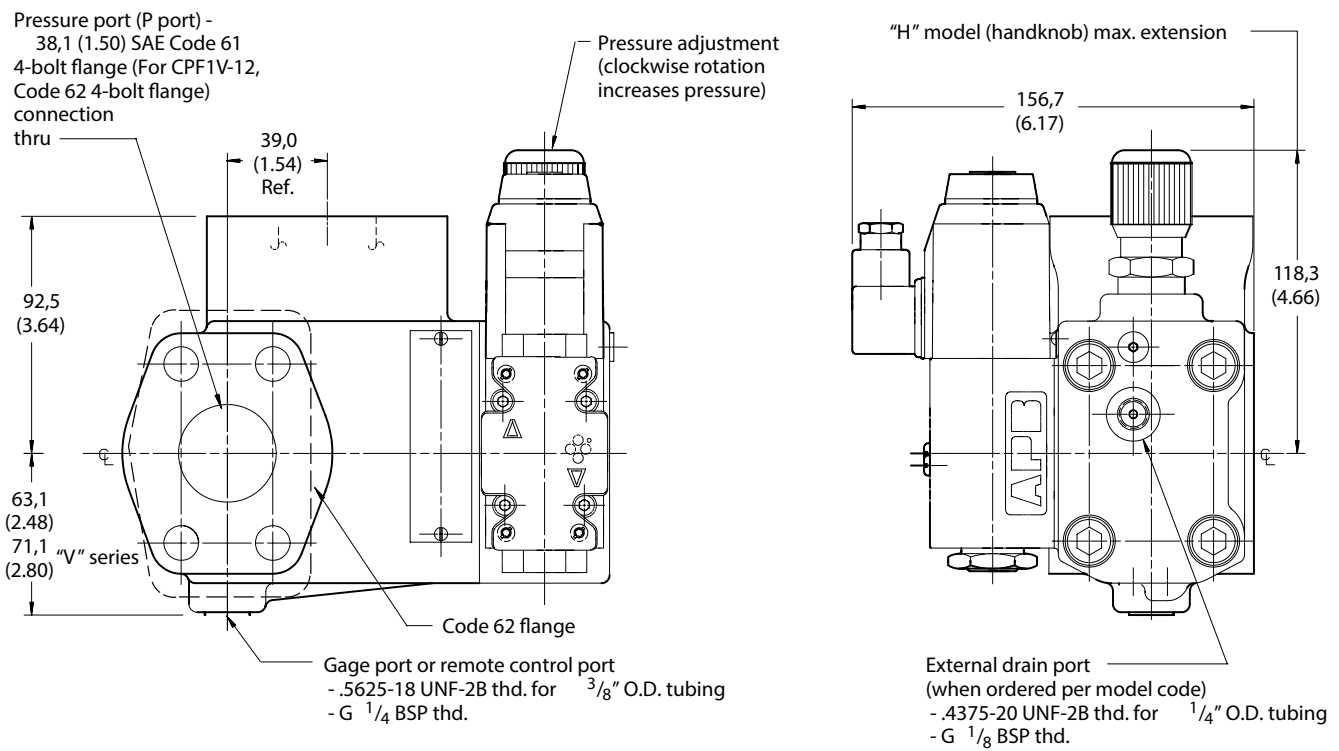
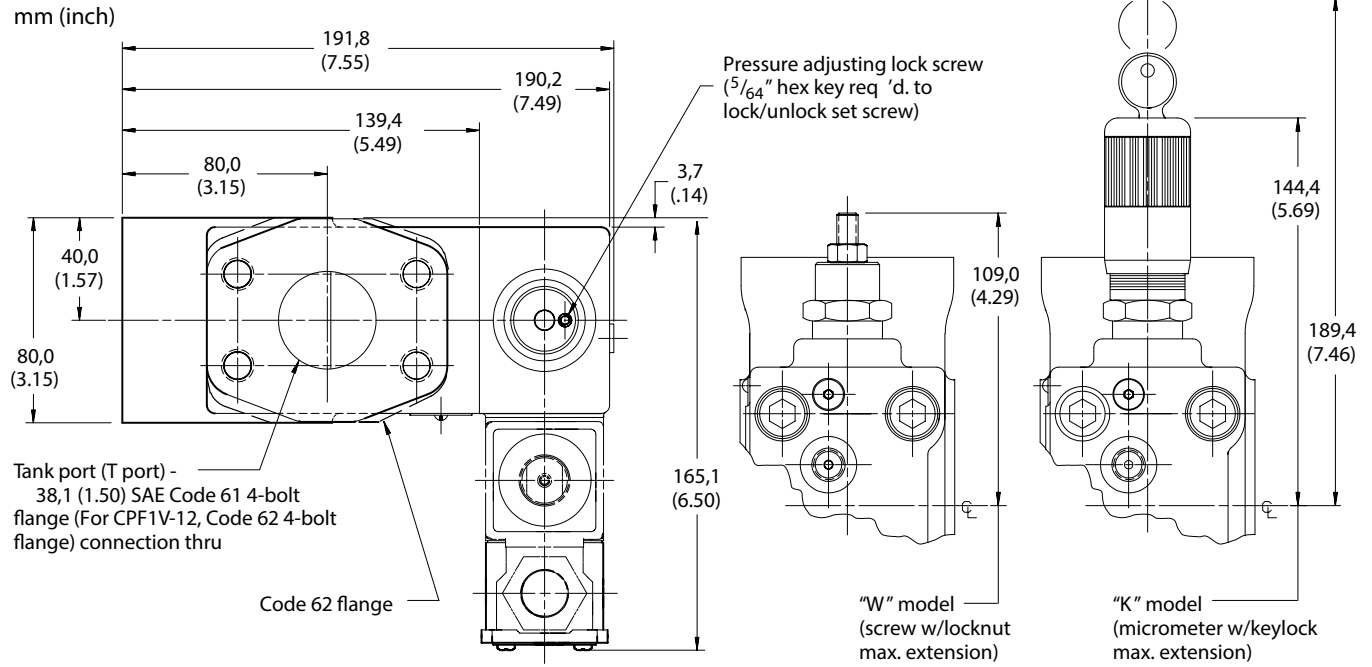

# CPF3/4\*-06/08/10/12-\*\*-20

## Bi-Pressure & Tri-Pressure Relief Valves With Venting

### Flange Sizes

- 06 - 3/4 inch flange
- 08 - 1 inch flange
- 10 - 1 1/4 inch flange
- 12 - 1 1/2 inch flange

### Benefits

- Excellent repeatability and stable performance from cartridge design mainstage parts.
- Reduced installed costs and space requirements.
- Easier installation and servicing of components.
- Pilot design minimizes response time and cracking flow which allows for high pressure stability thus increasing system productivity.
- Direct mounting to pump flange reduces potential leak points for superior leak resistance.

Ratings	CPF3/4S-06	CPF3/4S-08	CPF3/4S-10	CPF3/4S-12
Maximum flow	100 l/min (26 USgpm)	300 l/min (80 USgpm)	600 l/min (160 USgpm)	600 l/min (160 USgpm)
Maximum pressure:				
P port	275 bar (4000 psi)	275 bar (4000 psi)	275 bar (4000 psi)	275 bar (4000 psi)*
T port	207 bar (3000 psi)	207 bar (3000 psi)	207 bar (3000 psi)	207 bar (3000 psi)

\* The CPF2V-12 (code 62 flange) has a max. P port pressure rating of 350 bar (5000 psi).

### Pilot Valve Max. T Port Pressure Rating

100 bar (1450 psi) for DG4V-3S valve  
 210 bar (3045 psi) for DG4V-3 valve AC  
 210 bar (3045 psi) for DG4V-3 valve DC

### Electrical Response

Electrical response is defined as the time from initiation of power to the solenoid, to the initiation of pressure rise, with 1,5 liters (.4 USgpm) of oil under compression:

06 size –  
 @100 l/min (26 USgpm) = DC - 200 ms  
 AC - 160 ms  
 08 size –  
 @300 l/min (80 USgpm) = DC - 210 ms  
 AC - 175 ms  
 10/12 size -  
 @300 l/min (80 USgpm) = DC - 180 ms  
 AC - 160 ms

### Hydraulic Response

06 Size: Rate of pressure rise with 2,5 liters (.7 USgpm) of oil under compression = 3450 bar (50000 psi) /second. Maximum overshoot < 8%.

08 Size: Rate of pressure rise with 2,5 liters (.7 USgpm) of oil under compression = 2900 bar (42000 psi) /second. Maximum overshoot < 10%.

10/12 Sizes: Rate of pressure rise with 2,5 liters (.7 USgpm) of oil under compression = 2600 bar (37500 psi) /second. Maximum overshoot < 10%.

### General Description

This Vickers by Danfoss CPF3/4S relief valve features flange mounting for increased design flexibility and reduced external piping. The valve is designed for direct mounting on the SAE flange outlet port of a pump. Fewer leak points and SAE flange connections lead to installations with superior leak resistance.

Pressure relief valves are used to limit or control pressure by directing system flow to the reservoir when system pressure reaches the setting of the valve. System overload is thereby prevented and peak pressures which

could damage the pump and actuating components are eliminated.

This valve features an integrally mounted 3-position solenoid vent valve which requires no additional piping. Energizing the "a" or "b" solenoid selects pressure setting (2) or (1) respectively. With neither solenoid energized the relief valve is vented to limit system pressure to the maximum vent pressure. The CPF4S tri-pressure relief valve is a pressure control unit which can be used to electrically select any one of three preset pressures, or two pressures and vent with the CPF3S.

The CPF3/4S valve has excellent dynamic and steady state operating characteristics including stability, fast response and low pressure override. CPF relief valves are of two-stage design with a fast –acting poppet type main stage for simple, long-lasting and effective operation. The many available control options make it possible to choose the optimum valve model for each application.



# CPF3/4\* Model Series

## Model Code

**CPF\*\* - \*\* - \*\*\* - \* - (B) - (RC) - (1) - 3(S) (\*) (V) - M - (S\*) - \*\*\* (L) - \*\* - 20**

1 2 3 4 5 6 7 8 9 10 11 12 13 14 15 16 17 18 19 20 21 22

### 1 Valve Function

C - Relief

### 2 Mounting Type

PF - Pump flange mounting

### 3 Unit Type

3 - Bi-pressure with max. pressure override  
4 - Tri-pressure

### 4 Flange Type

S - SAE J518 4-bolt flange standard series code 61 (available all sizes)  
V - SAE J518 4-bolt high pressure series code 62 (size 12 only)

### 5 Valve Size

06 - 3/4 inch  
08 - 1 inch  
10 - 1 1/4 inch  
12 - 1 1/2 inch

### 6 Head 1 Pressure Range

A - 10 - 50 bar (145 - 725 psi)  
B - 10 - 100 bar (145 - 1450 psi)  
F - 10 - 207 bar (145 - 3000 psi)  
G - 10 - 275 bar (145 - 4000 psi)  
350 bar (5000 psi) - (CPF\*V-12 models only)

### 7 Head 2 Pressure Range

A - 10 - 50 bar (145 - 725 psi)  
B - 10 - 100 bar (145 - 1450 psi)  
F - 10 - 207 bar (145 - 3000 psi)  
G - 10 - 275 bar (145 - 4000 psi)  
350 bar (5000 psi) - (CPF\*V-12 models only)

### 8 Head 3 Pressure Range

A - 10 - 50 bar (145 - 725 psi)  
B - 10 - 100 bar (145 - 1450 psi)  
F - 10 - 207 bar (145 - 3000 psi)  
G - 10 - 275 bar (145 - 4000 psi)  
350 bar (5000 psi) - (CPF\*V-12 models only)

Note: Head 3 is the maximum pressure override adjustment. The pressure range selection should be at least 17 bar (250 psi) higher than those for Heads 1 and 2.

### 9 Control Type

W - Screw adjust with locknut  
H - Handknob adjust without key  
K - Micrometer adjust with keylock

### 10 Thread Type

Remote Control/Vent Connection  
Blank - SAE-6 O-ring boss port (.5625-18 UNF-2B thd.)  
B - BSP-G 1/4 (1/4" BSPF)

### 11 Remote Control

Blank - No remote control  
RC - Remote Control

### 12 Pilot Drain

Blank - Internal drain  
1 - External drain

### 13 Vent Valve

3S - Standard performance  
3 - High performance  
Uses 0C type spool/spring for CPF3 and 2C type spool/spring for CPF4; other features are optional. Refer to Vickers by Danfoss literature # GB-C-2015B Solenoid Operated Directional Control Valves catalog.

### 14 Manual Override Options

### 15 Solenoid Energization Identification

### 16 Electrical Options Flag

### 17 Spool Position Monitoring Switch

### 18 Solenoid Type/Electrical Connections

### 19 Indicator Lights

### 20 Coil Voltage Identification

### 21 Tank Rating Pressure

2 - 10 bar (145 psi) for spool position indicator models.  
5 - 100 bar (1450 psi) for standard performance models, DG4V-3S, with AC or DC solenoids.  
6 - 207 bar (3000 psi) for high performance models, DG4V-3, with AC solenoids.  
7 - 207 bar (3000 psi) for high performance models, DG4V-3 with DC solenoids.

### 22 Design Number, 20 Series

Subject to change. Installation dimensions unaltered for design numbers 20 to 29 inclusive.

# Circuit Schematics

CPF3S-06/08-\*-20

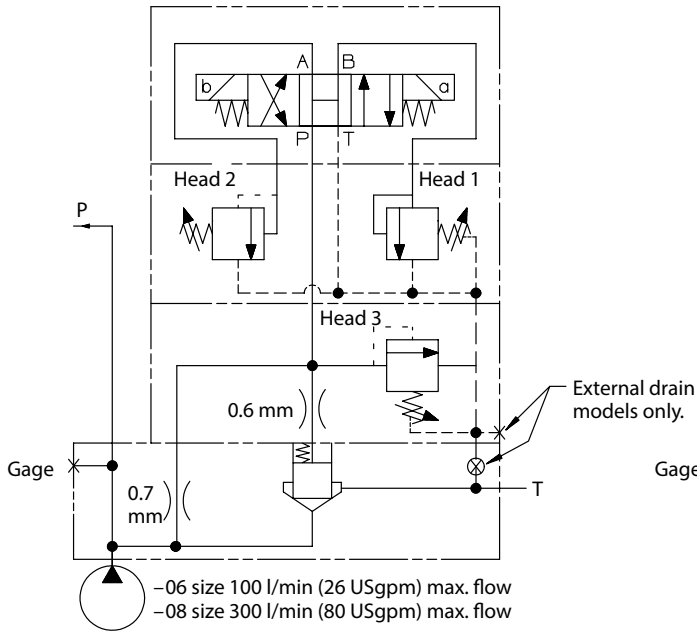

CPF4S-06/08-\*-20

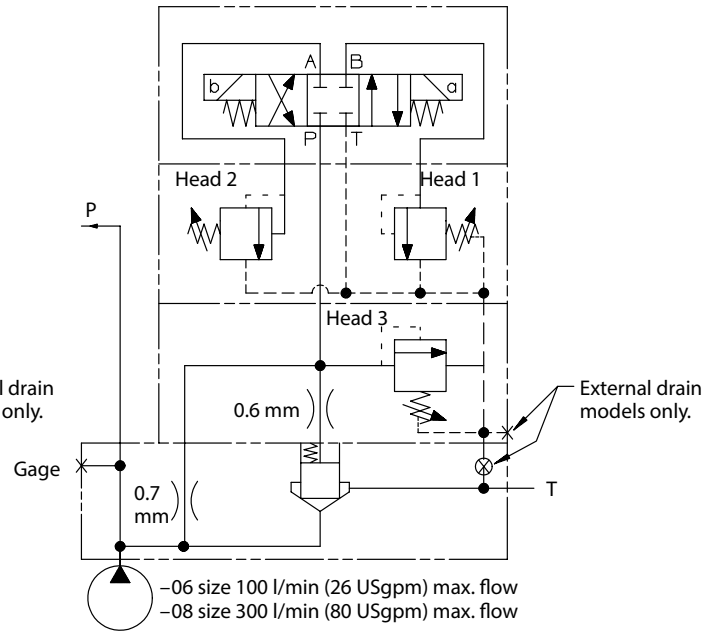

CPF3S-10/12-\*-20  
CPF3V-12-\*-20

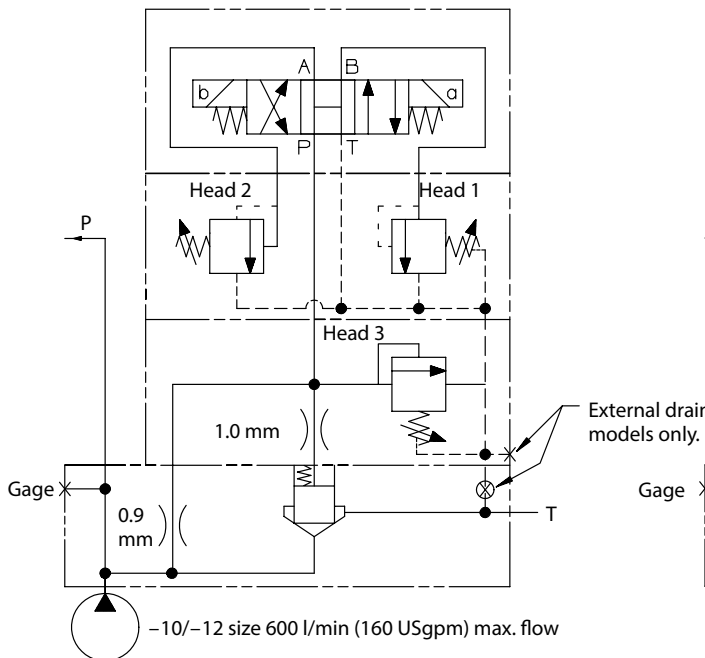

CPF4S-10/12-\*-20  
CPF4V-12-\*-20

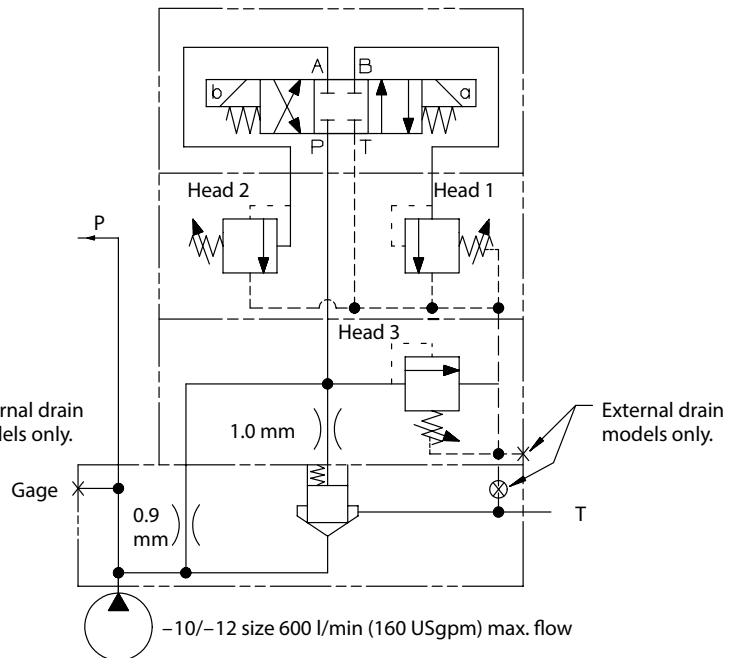

# Pressure Curves

CPF3/4S-06

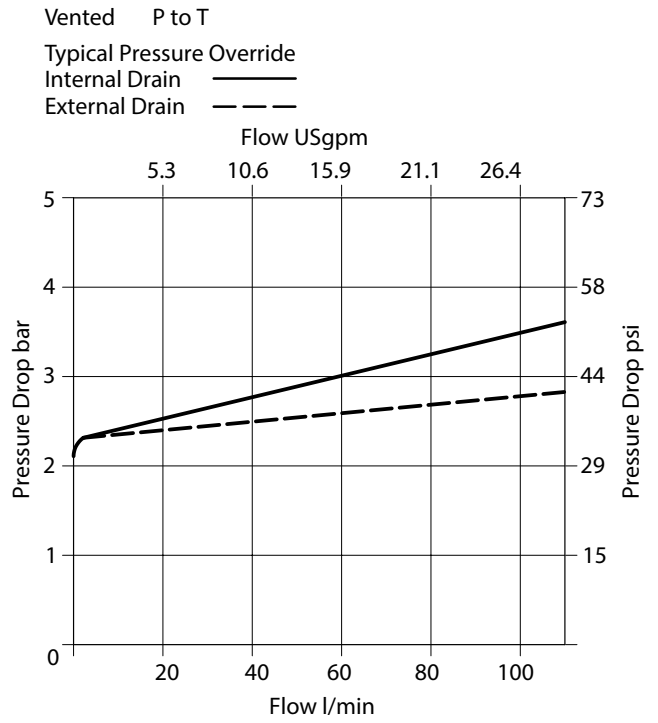
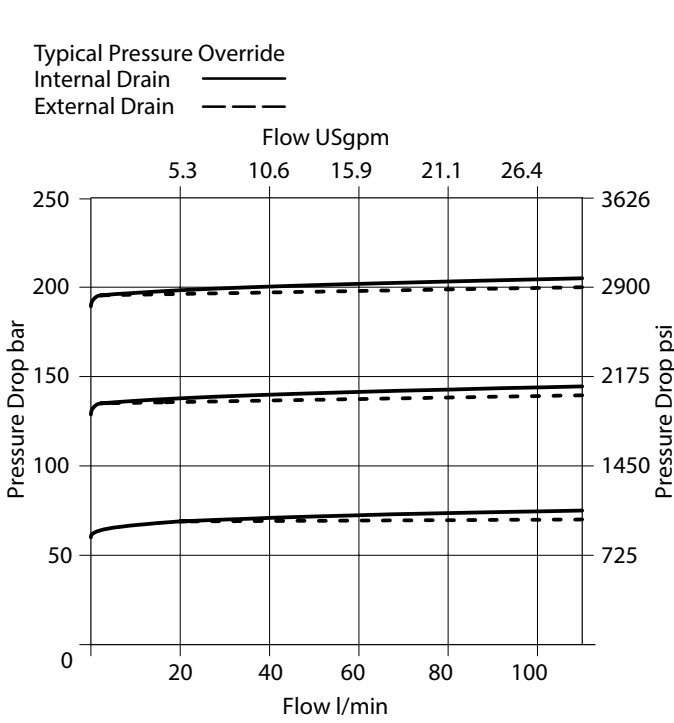

CPF3/4S-08

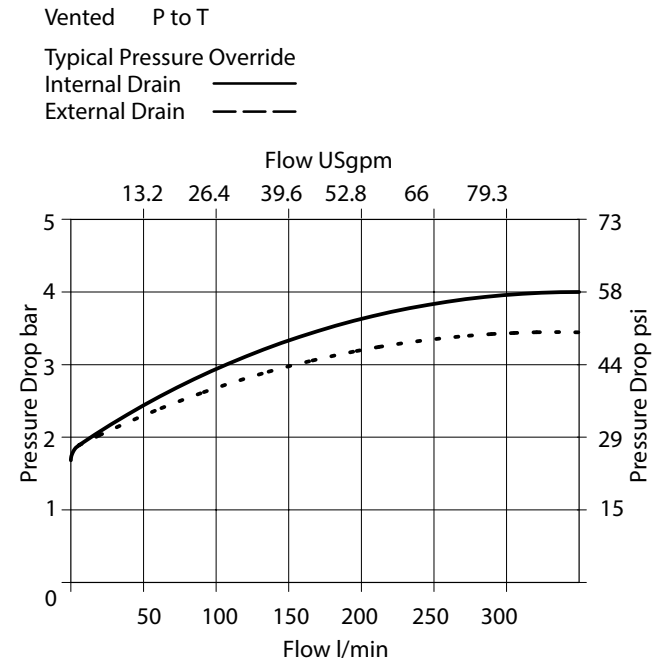
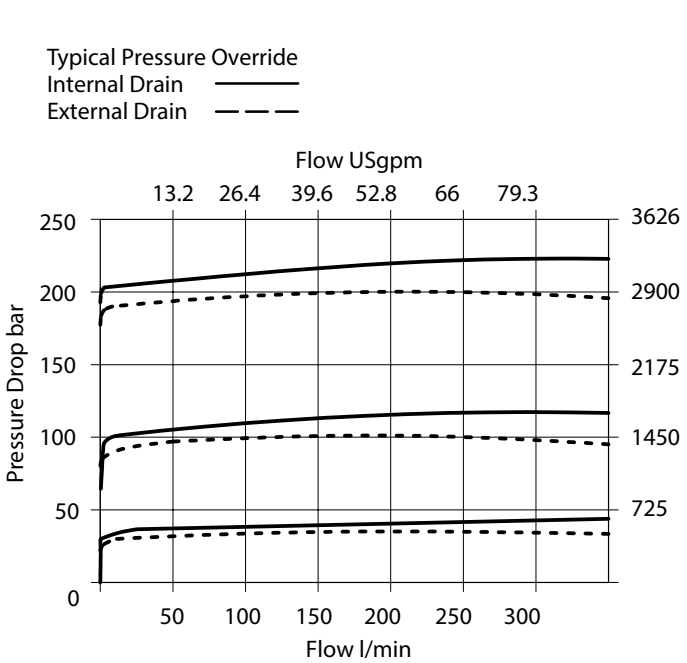

CPF3/4S-10

Typical Pressure Override  
 Internal Drain ———  
 External Drain - - - - -

Vented P to T  
 Internal Drain ———  
 External Drain - - - - -

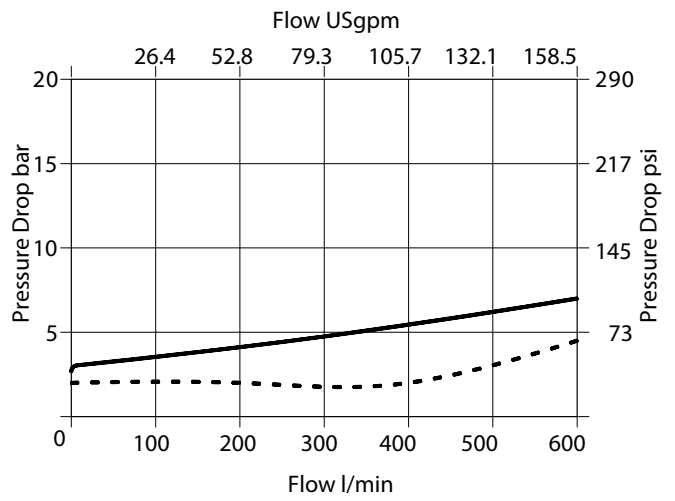
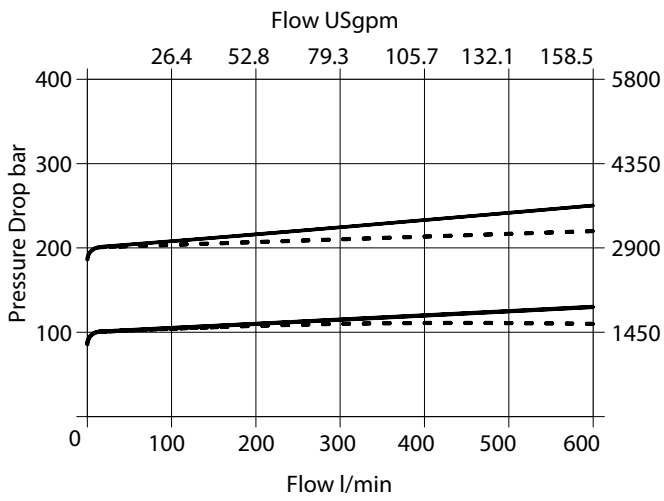

CPF3/4S-12  
 CPF3/4V-12

Typical Pressure Override  
 Internal Drain ———  
 External Drain - - - - -

Vented P to T  
 Internal Drain ———  
 External Drain - - - - -

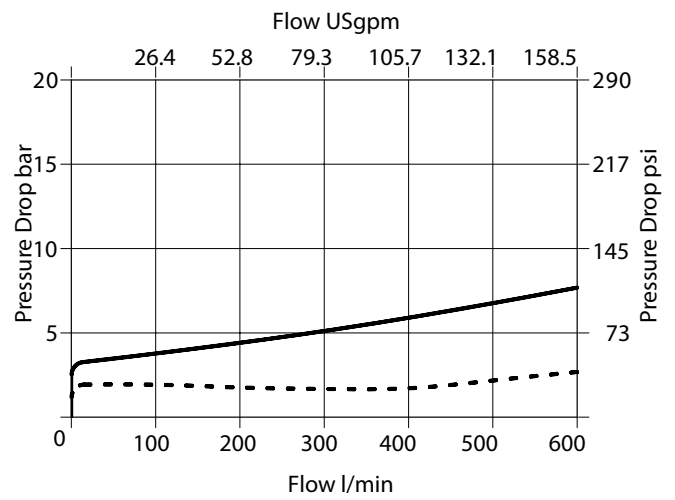
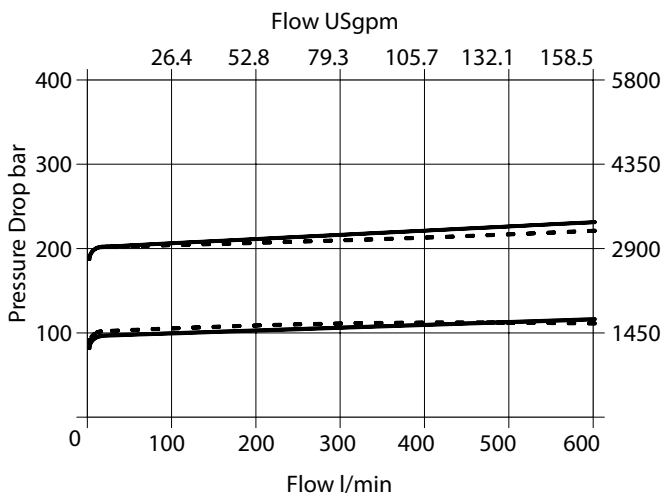

# Installation Dimensions

## CPF3/4S-06 3/4" Flange - Bi-Pressure With Safety & Tri-Pressure Relief Valve

mm (inch)

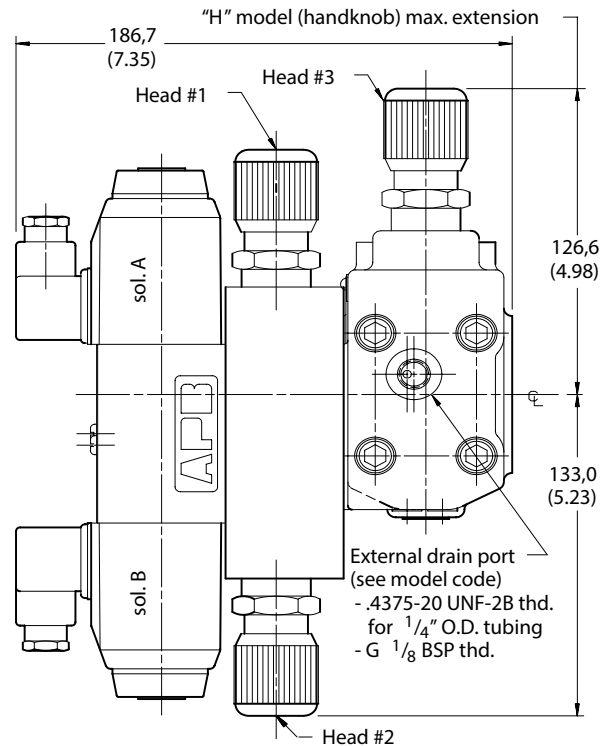
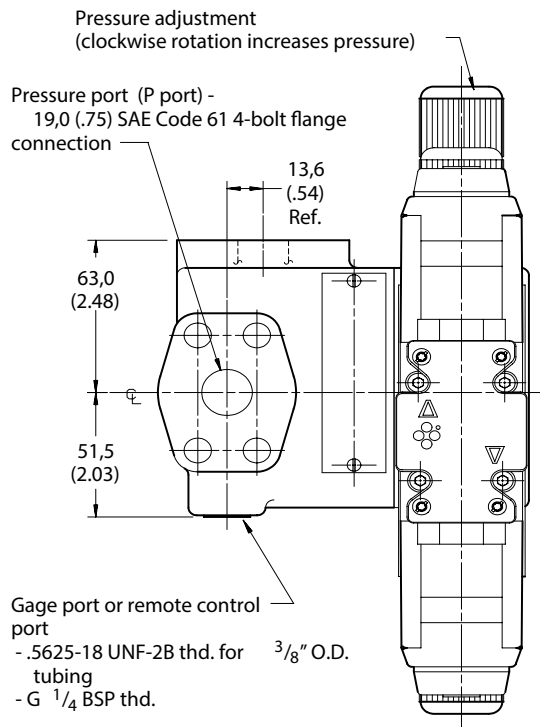
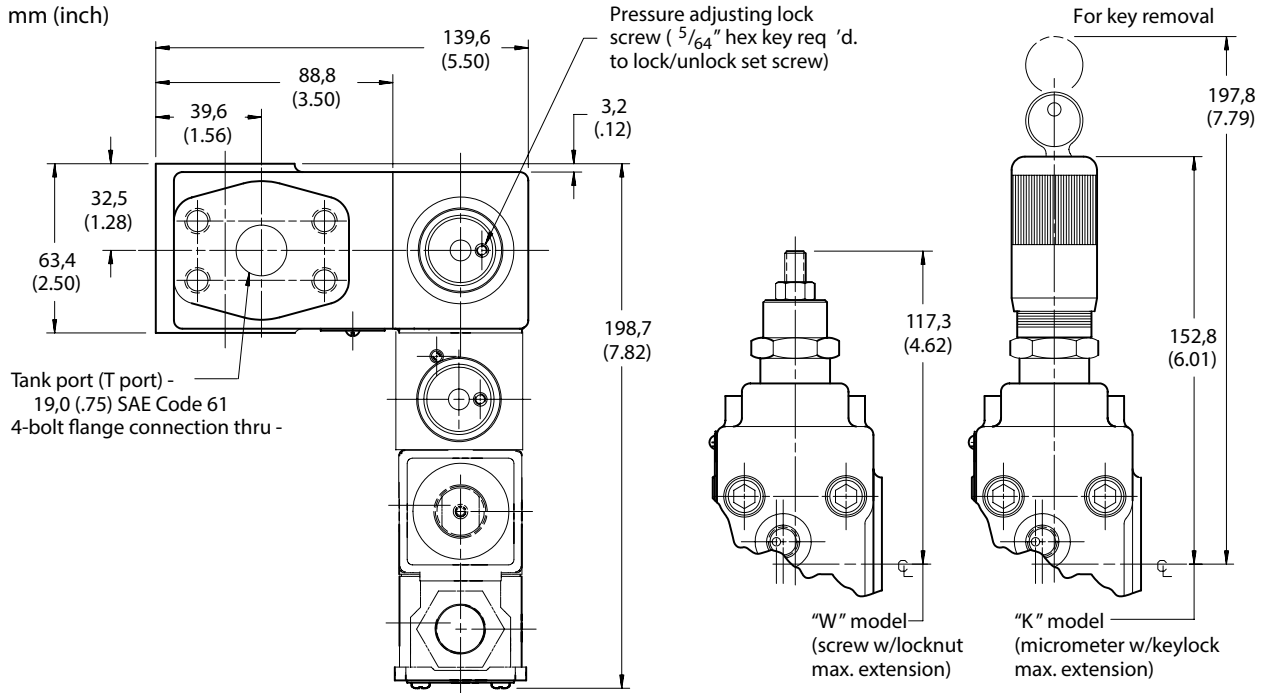

# CPF3/4S-08 1 " Flange - Bi-Pressure With Safety & Tri-Pressure Relief Valve

mm (inch)

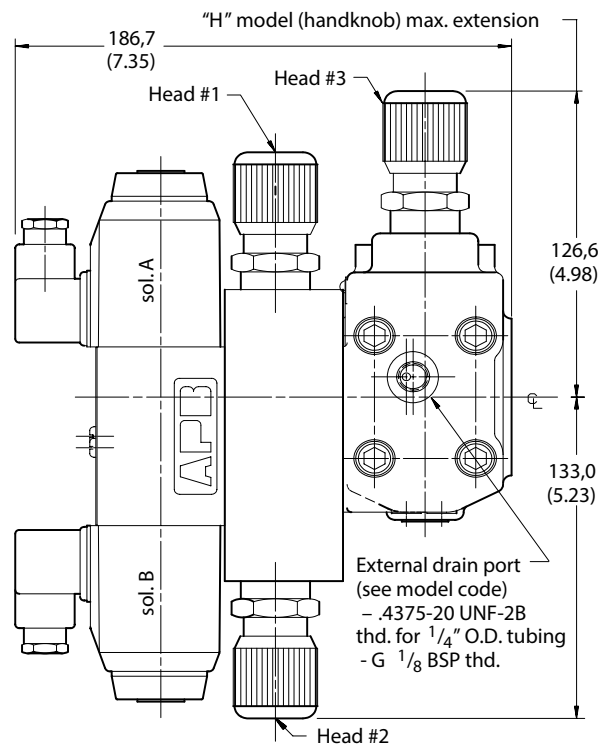
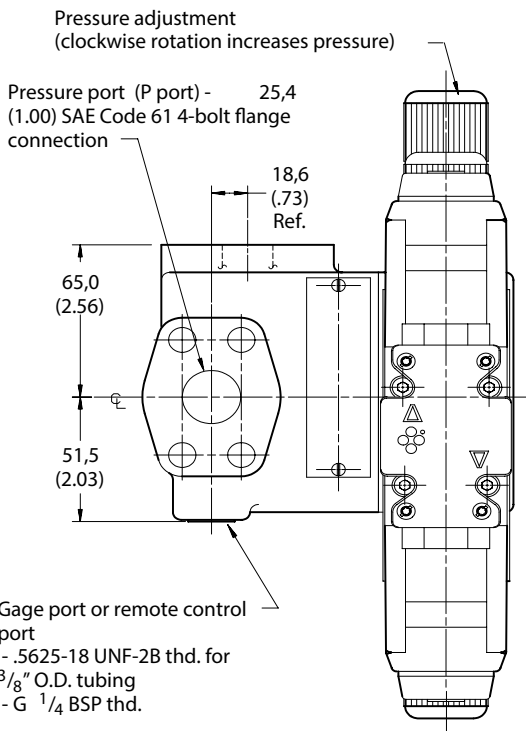
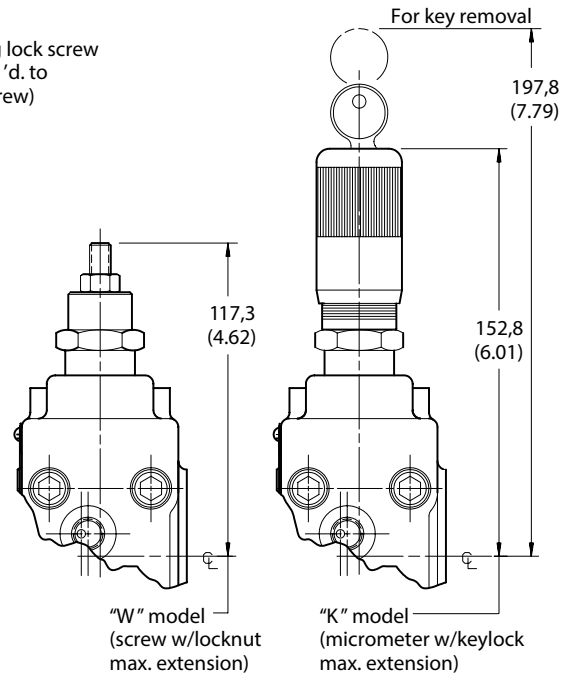
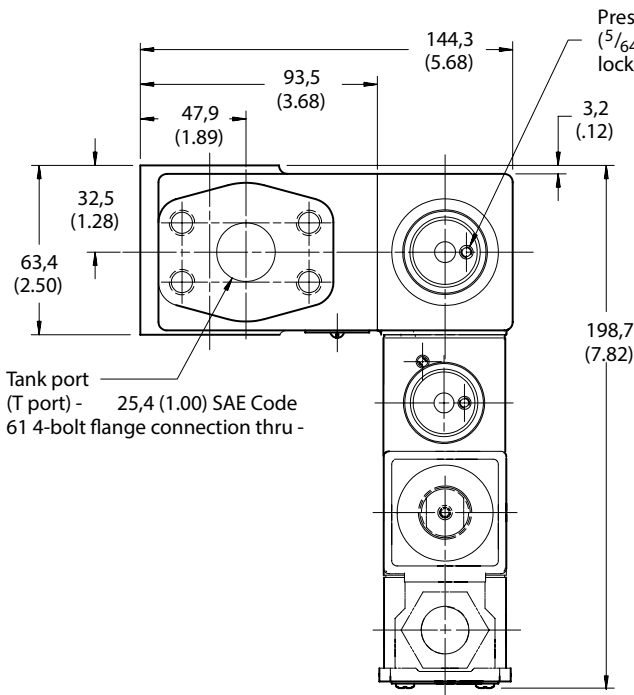

# CPF3/4S-10 1 1/4" Flange - Bi-Pressure With Safety & Tri-Pressure Relief Valve

mm (inch)

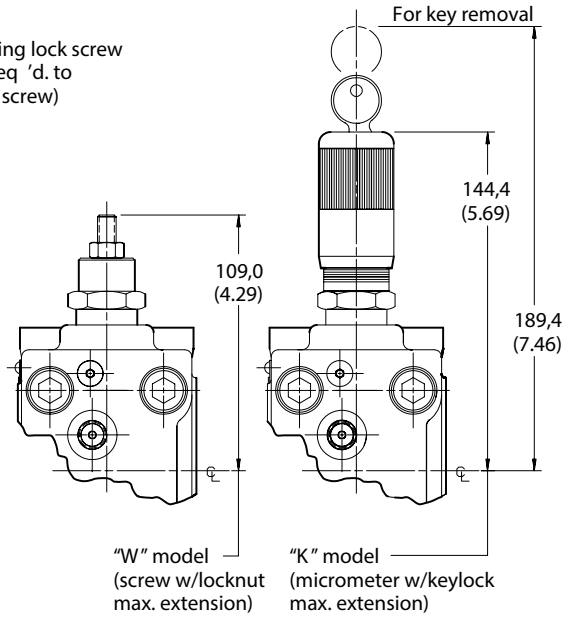
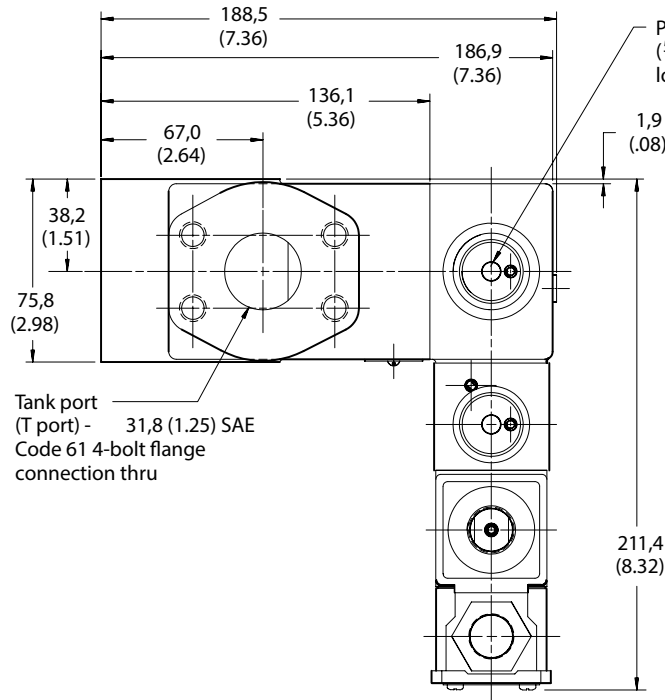

Pressure adjustment (clockwise rotation  
increases pressure)

Pressure port (P port) -  
31,8 (1.25) SAE Code 61  
4-bolt flange connection  
thru

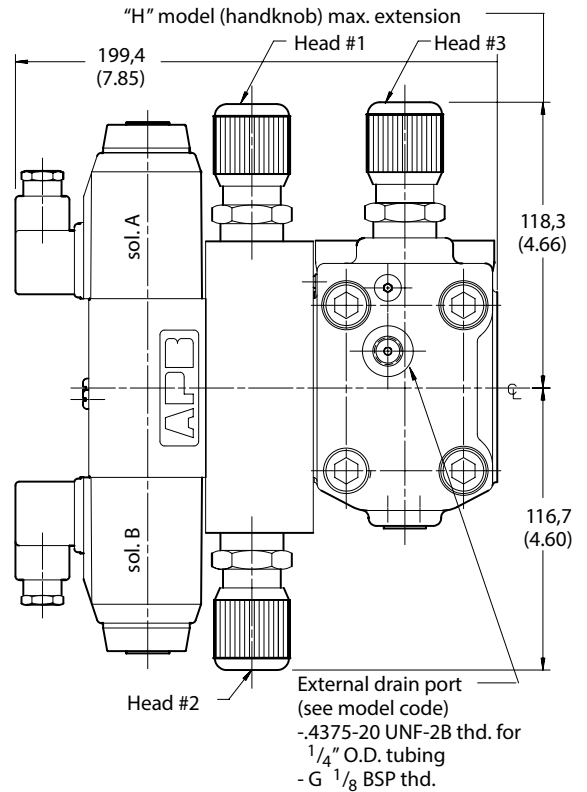
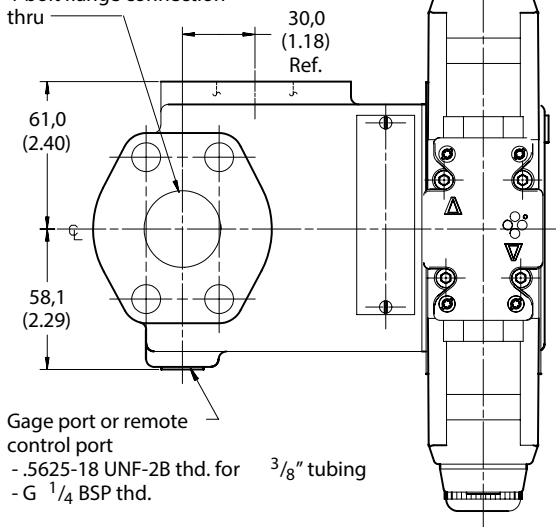

CPF3/4S-12 – Code 61  
 CPF3/4V-12 – Code 62  
 1½" Flange -  
 Bi-Pressure With Safety &  
 Tri-Pressure Relief Valve

mm (inch)

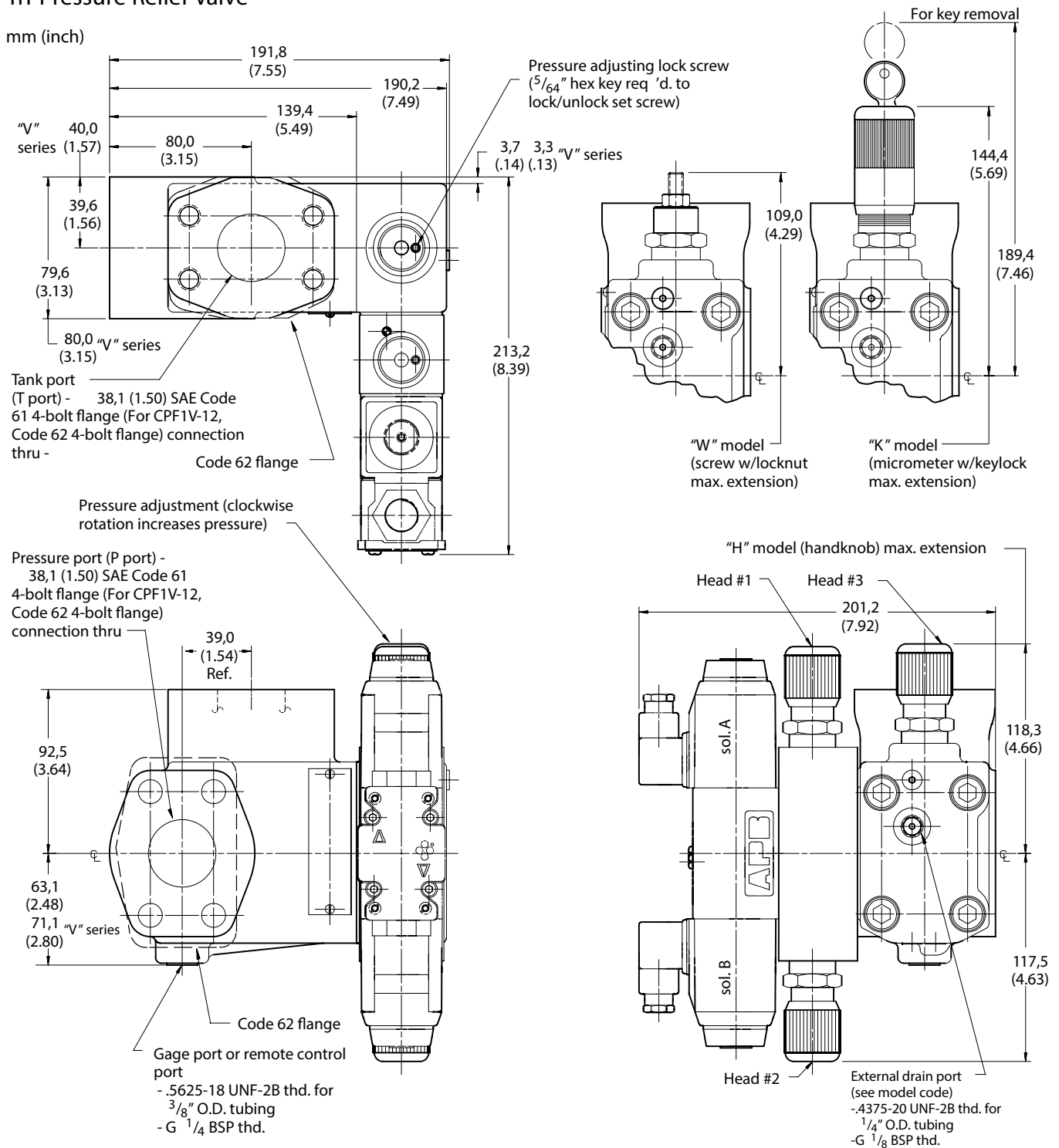



# UPF1\*-(\*\*)-06/08/10/12-\*\*-20

## Unloading Valves - Without Vent

### Flange Sizes

- 06 - 3/4 inch flange
- 08 - 1 inch flange
- 10 - 1 1/4 inch flange
- 12 - 1 1/2 inch flange

### Benefits

- Excellent repeatability and stable performance from cartridge design mainstage parts.
- Reduced installed costs and space requirements.
- Easier installation and servicing of components.
- Pilot design minimizes response time and cracking flow which allows for high pressure stability thus increasing system productivity.
- Direct mounting to pump flange reduces potential leak points for superior leak resistance.
- Multi-fluid capability without the need to change seals.

Ratings	UPF1S-06	UPF1S-08	UPF1S-10	UPF1S-12*
Maximum flow:	100 l/min (26 USgpm)	300 l/min (80 USgpm)	600 l/min (160 USgpm)	600 l/min (160 USgpm)
External drain	300 l/min (80 USgpm)	300 l/min (80 USgpm)		
Internal drain	151 l/min (40 USgpm)	151 l/min (40 USgpm)		
Maximum pressure:				
P port	275 bar (4000 psi)	275 bar (4000 psi)	275 bar (4000 psi)	275 bar (4000 psi)*
T port	207 bar (3000 psi)	207 bar (3000 psi)	207 bar (3000 psi)	207 bar (3000 psi)

\* The UPF1V-12 (code 62 flange) has a max. P port pressure rating of 350 bar (5000 psi).

### General Description

This Vickers by Danfoss UPF1S unloading valve features flange mounting for increased design flexibility and reduced external piping. The valve is designed for direct mounting on the SAE flange outlet port of a pump. Fewer leak points and SAE flange connections lead to installations with superior leak resistance.

Unloading valves are used in accumulator charging circuits where a pressure regulator is required to automatically unload the pump by diverting the pump delivery to the reservoir, at low pressure, when the

desired accumulator pressure is reached. These valves may also be used to unload the low pressure side of double pumps. The unloading valves also function as pressure relief valves when the remote pressure is lower than the plunger pressure setting.

In construction, an unloading valve contains a compound relief valve with a poppet-type main stage, an integral (when ordered per model code) check valve to prevent reverse flow from the accumulator, and a pressure operated plunger which vents the relief valve at the selected pressure.

The UPFS valve has excellent dynamic and steady state operating characteristics including stability, fast response and low pressure override

UPF valves are of two –stage design with a fast –acting poppet type main stage for simple, long –lasting and effective operation. The many available control options make it possible to choose the optimum valve model for each application.

# UPF1\* Model Series

## Model Code

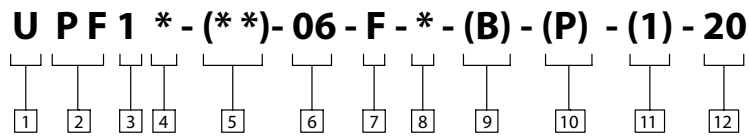

<p><b>1</b> Valve Function</p> <p>U - Unloading valve</p>	<p><b>6</b> Valve Size</p> <p>06 - 3/4 inch            08 - 1 inch            10 - 1 1/4 inch            12 - 1 1/2 inch</p>	<p><b>9</b> Thread Type            (remote control/vent connection)</p> <p>Blank - SAE-6 O-ring boss port            (.5625-18 UNF-2B thd.)            B - BSP-G 1/4 (1/4" BSPF)</p>
<p><b>2</b> Mounting Type</p> <p>PF - Pump flange mounting</p>	<p><b>7</b> Pressure Adjustment Range</p> <p>A - 9 - 70 bar (130 - 1000 psi)            B - 9 - 125 bar (130 - 1800 psi)            F - 9 - 245 bar (130 - 3600 psi)            G - 9 - 275 bar (130 - 4000 psi)            350 bar (5000 psi) - (UPF1V-12 models only)</p>	<p><b>10</b> Accumulator Sense Port</p> <p>Blank - Internal sense port            P - External sense port (not available on models w/integral check)</p>
<p><b>3</b> Unit type</p> <p>1 - Single pressure without vent</p>	<p><b>8</b> Control Type</p> <p>W - Screw adjust with locknut            K - Micrometer adjust with keylock            M - Micrometer adjust w/o keylock</p>	<p><b>11</b> Pilot Drain</p> <p>Blank - Internal drain            1 - External drain</p>
<p><b>4</b> Flange Type</p> <p>S - SAE J518 4-bolt flange standard series code 61 (available in all sizes)            V - SAE J518 4-bolt high pressure series code 62 (size 12 only)</p>	<p><b>5</b> Integral Check Valve*            (0,3 bar (5 psi) cracking pressure only)</p> <p>Blank - Without check valve            C - With right angle check - Not available with UPF1V-12            CL - With In-line check</p>	<p><b>12</b> Design Number, 20 series</p> <p>Subject to change. Installation dimensions unaltered for design numbers 20 to 29 inclusive.</p>

\* The integral check valve is not the same as the DCPFS right angle check valve.

# Circuit Schematics

UPF15-C\*-06/08-\*-20 with check valve

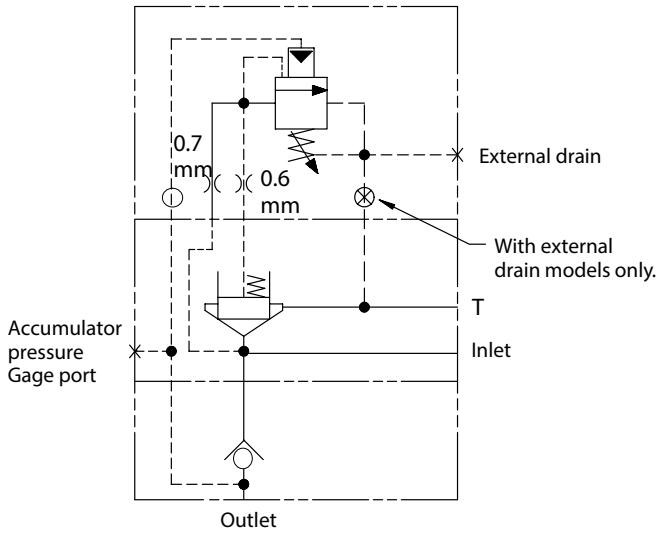

UPF15-06/08-(P)-\*-20 without check valve

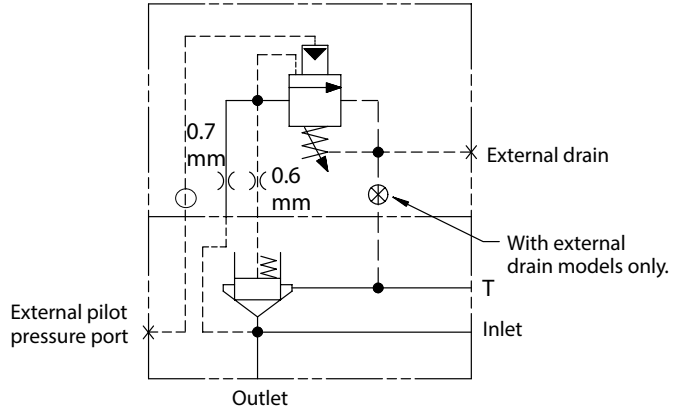

-06 size 100 l/min (26 USgpm) max. flow  
 -08 size 300 l/min (80 USgpm) external drain  
 150 l/min (40 USgpm) internal drain max. flow

UPF15-C\*-10/12-\*-20 with check valve

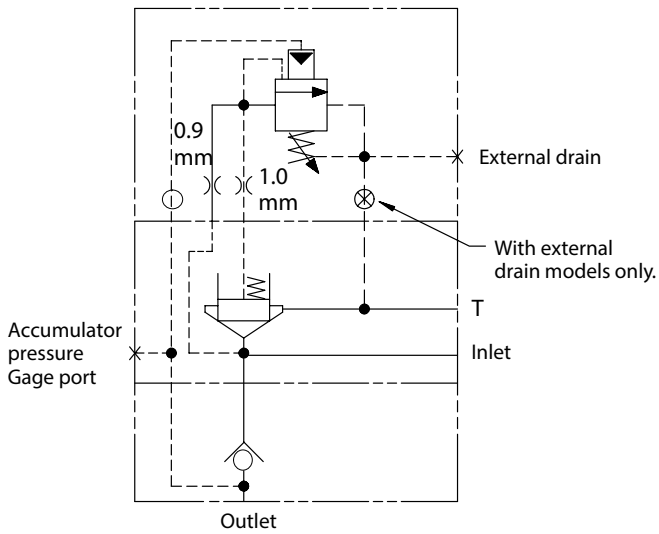

UPF15-10/12-(P)-\*-20 without check valve

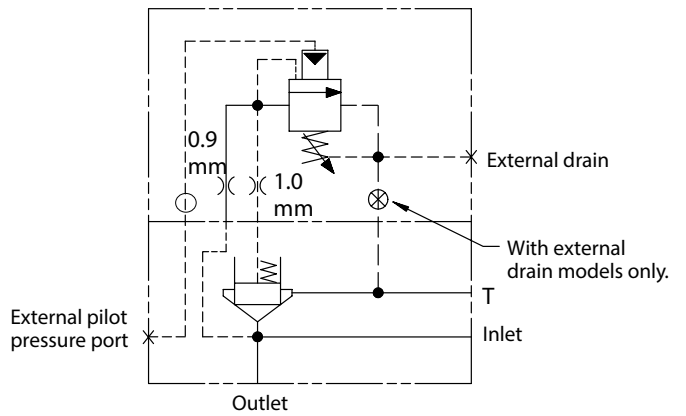

-10/-12 sizes 600 l/min (160 USgpm) max. flow

# Pressure Curves

## UPF1S-06

Unload vs Recharge P Pressure @100 l/min  
(26 USgpm) with integral check valve as supplied.

Internal Drain ———  
External Drain - - - -

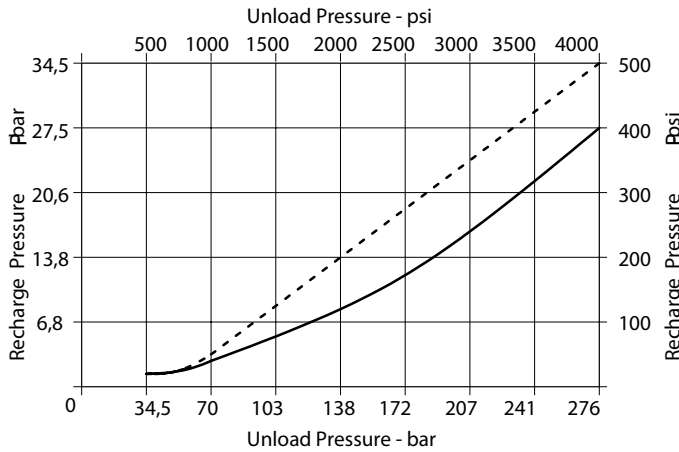

Vented P to T

Internal Drain ———  
External Drain - - - -

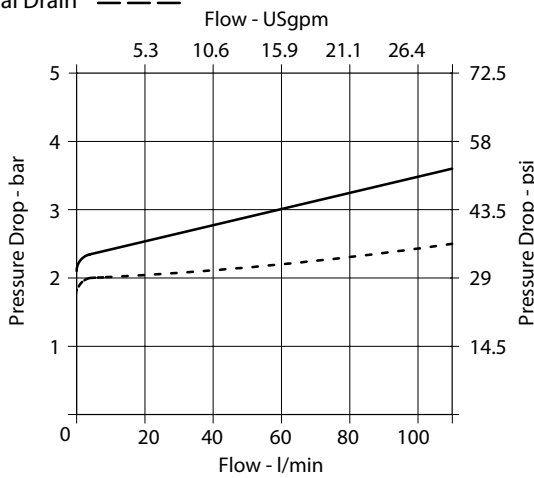

P P to P

With 0,34 bar (5 psi) Check Valve

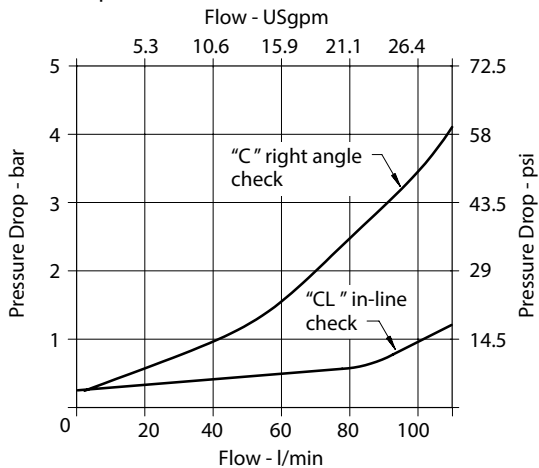

## UPF1S-08

Unload vs Recharge P Pressure with integral check valve as supplied.

Internal Drain ——— @150 l/min (40 USgpm)  
External Drain - - - - @300 l/min (80 USgpm)

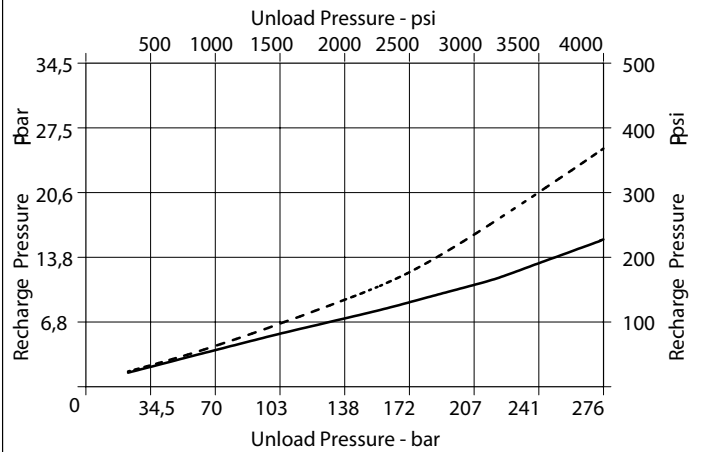

Vented P P to T

Internal Drain ———  
External Drain - - - -

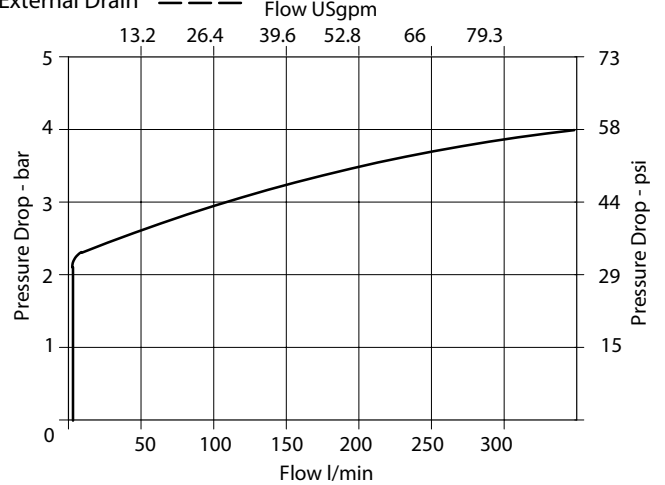

P P to P

With 0,34 bar (5 psi) Check Valve

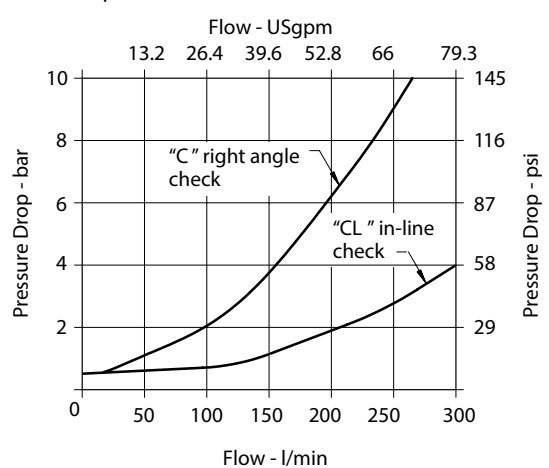

# Pressure Curves

## UPF1S-10

Unload vs Recharge P Pressure with integral check valve as supplied.

Internal Drain — @600 l/min (160 USgpm)  
External Drain - - - @600 l/min (160 USgpm)

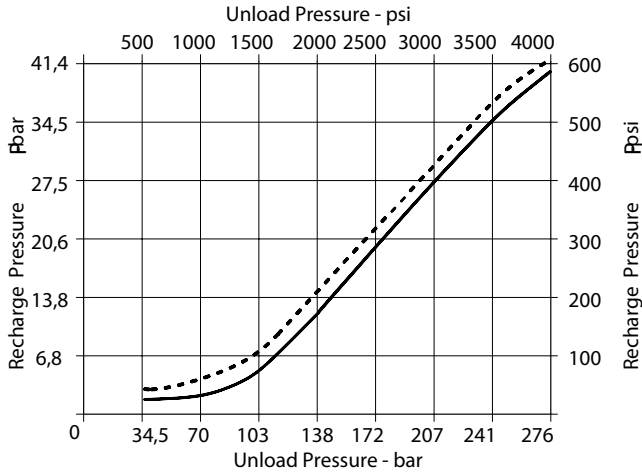

Vented P P to T

Internal Drain — @600 l/min (160 USgpm)  
External Drain - - - @600 l/min (160 USgpm)

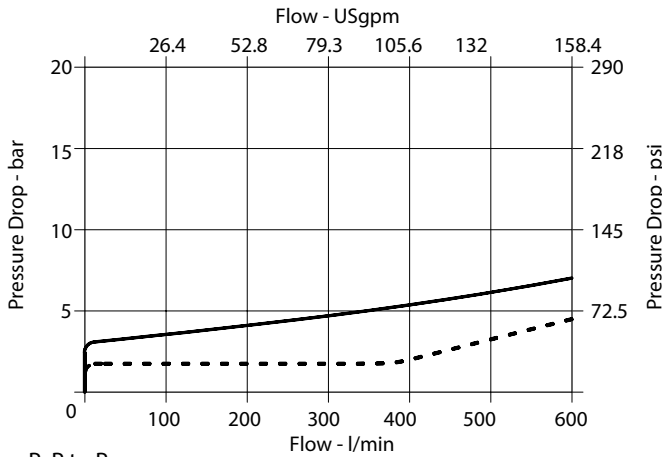

P P to P  
With 0,34 bar (5 psi) Check Valve

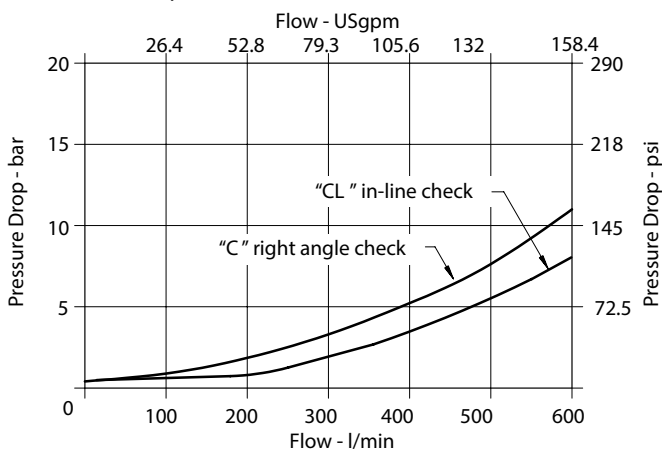

## UPF1S(V)-12

Unload vs Recharge P Pressure with integral check valve as supplied.

Internal Drain — @600 l/min (160 USgpm)  
External Drain - - - @600 l/min (160 USgpm)

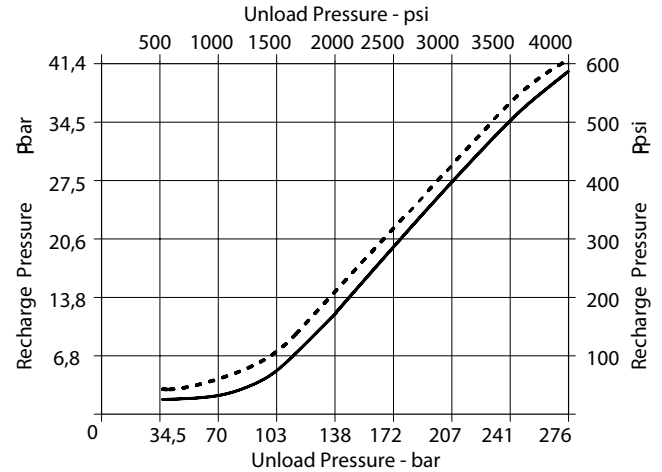

Vented P P to T

Internal Drain — @600 l/min (160 USgpm)  
External Drain - - - @600 l/min (160 USgpm)

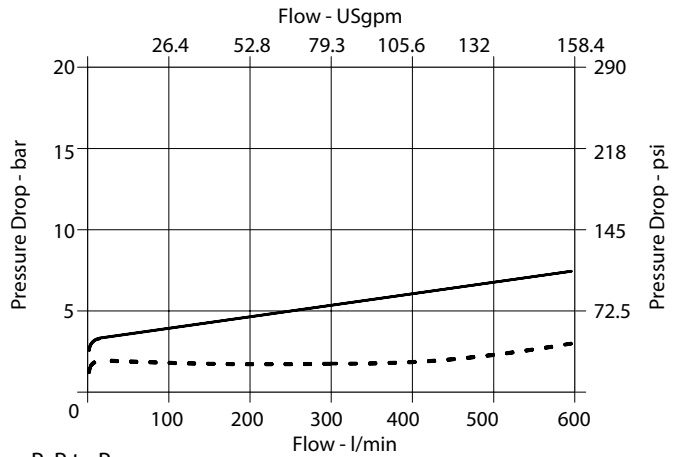

P P to P  
With 0,34 bar (5 psi) Check Valve

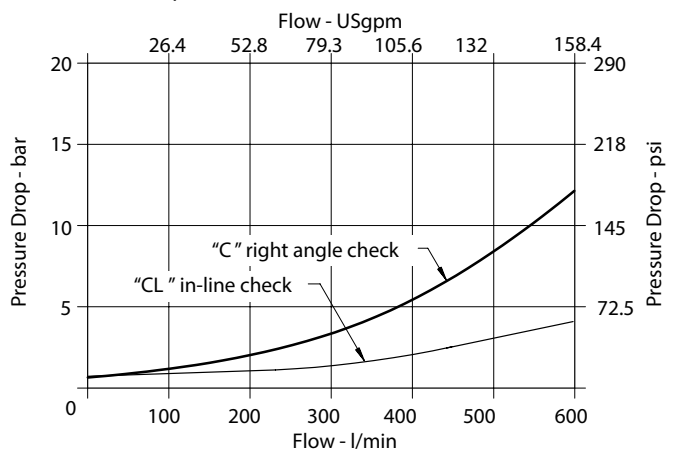

# Installation Dimensions

## UPF1S-06 3/4" Flange - Unloading Valve without Vent or Check

mm (inch)

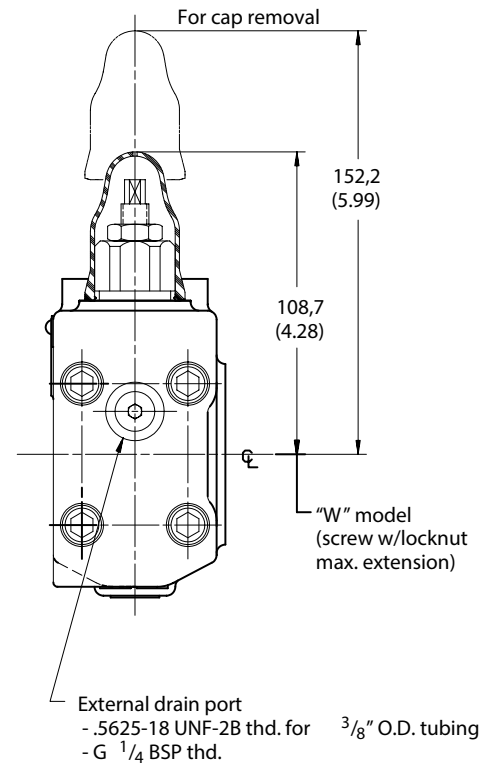
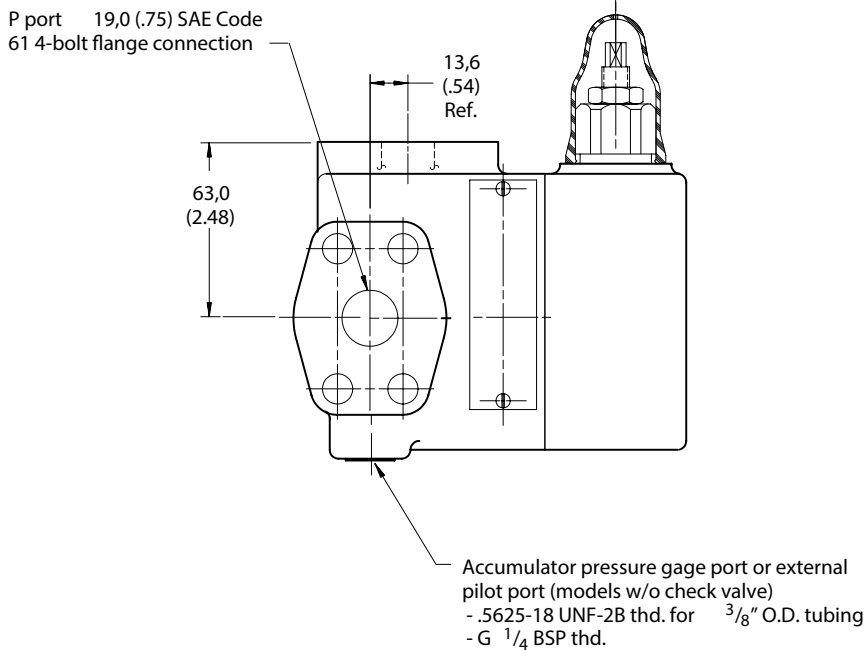
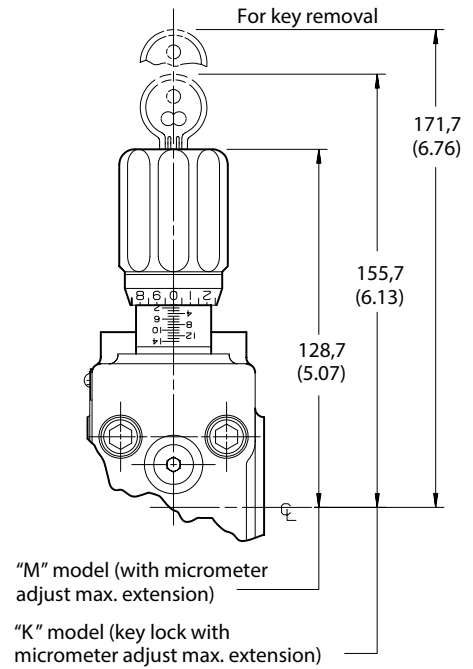
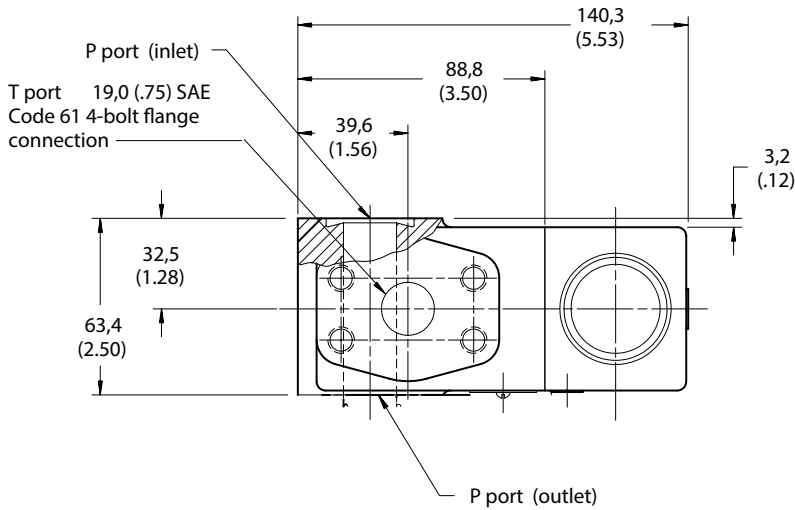

# Installation Dimensions

## UPF1S-C\*-06 3/4" Flange - Unloading Valve with Check without Vent

mm (inch)

**"C" Models**  
Right Angle Check

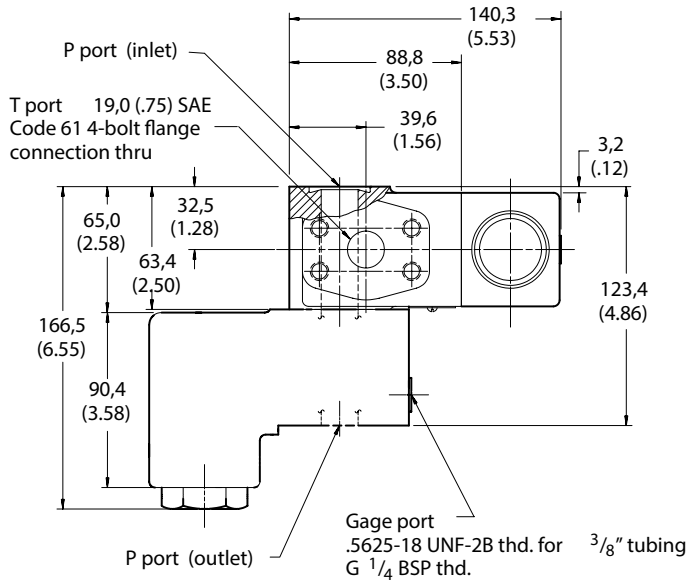

**"CL" Models**  
In-line Check

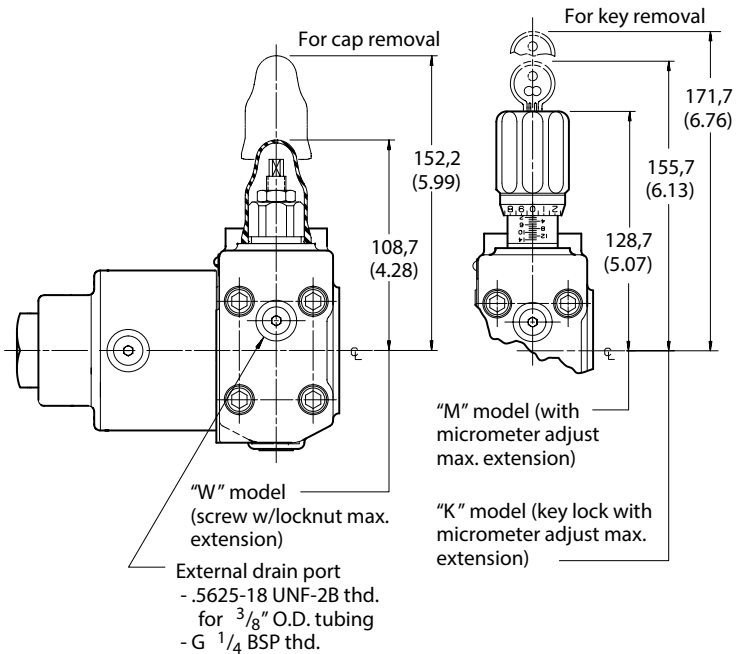
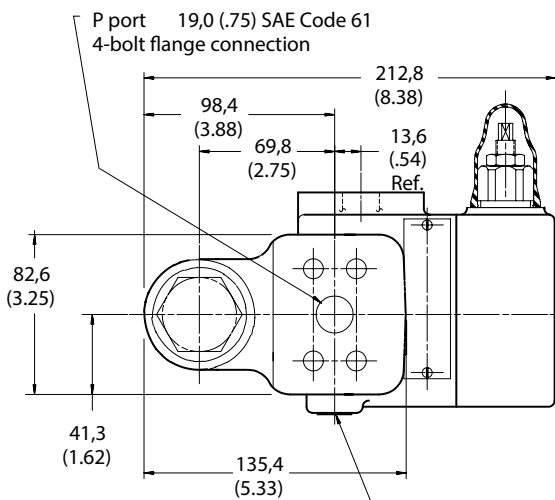
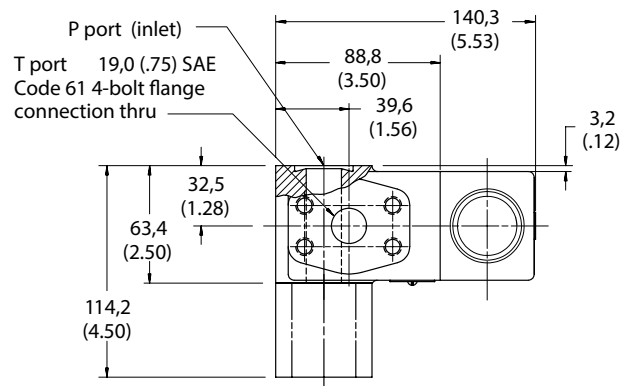

# UPF1S-08 1 " Flange - Unloading Valve without Vent or Check

mm (inch)

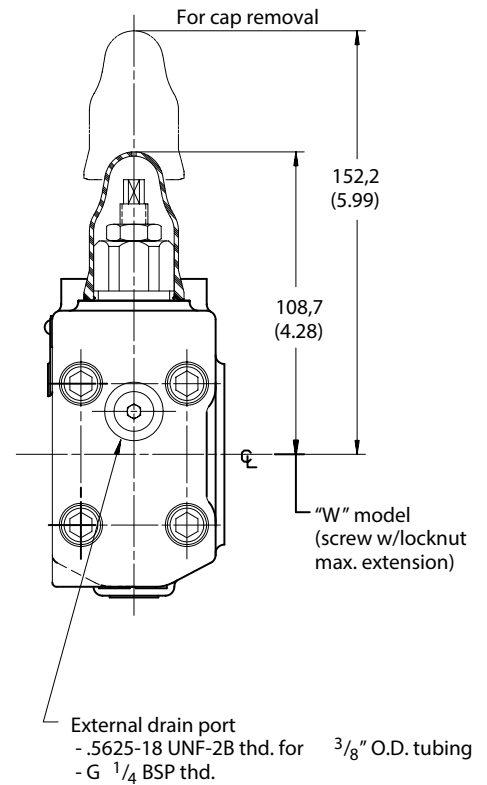
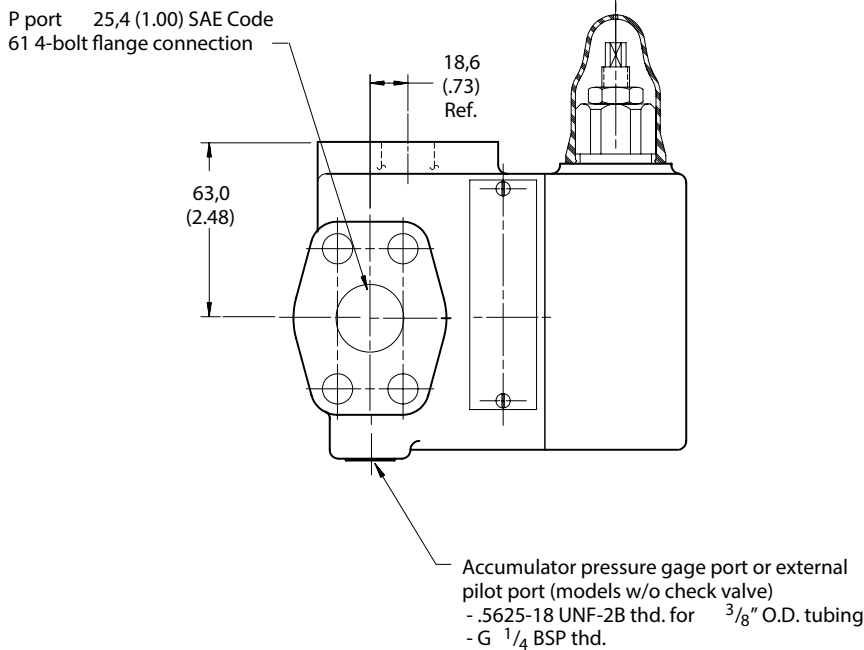
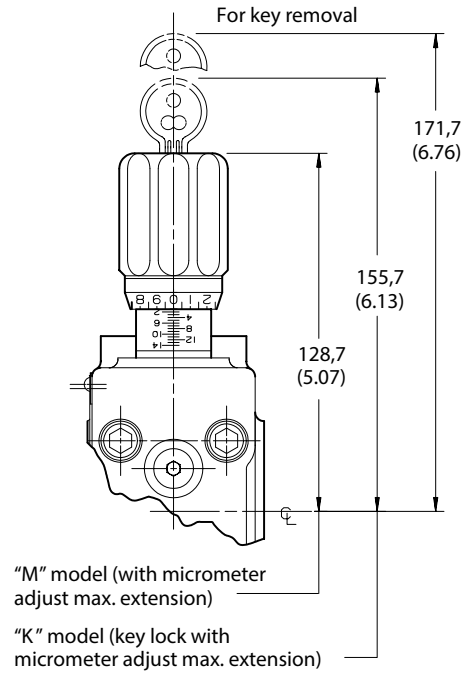
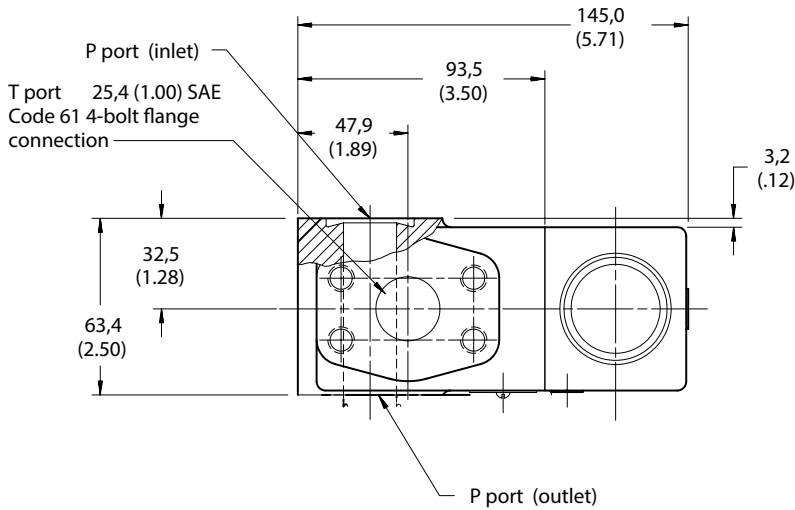



# UPF1S-C\*-08 1 " Flange - Unloading Valve with Check without Vent

mm (inch)

**"C" Models**  
Right Angle Check

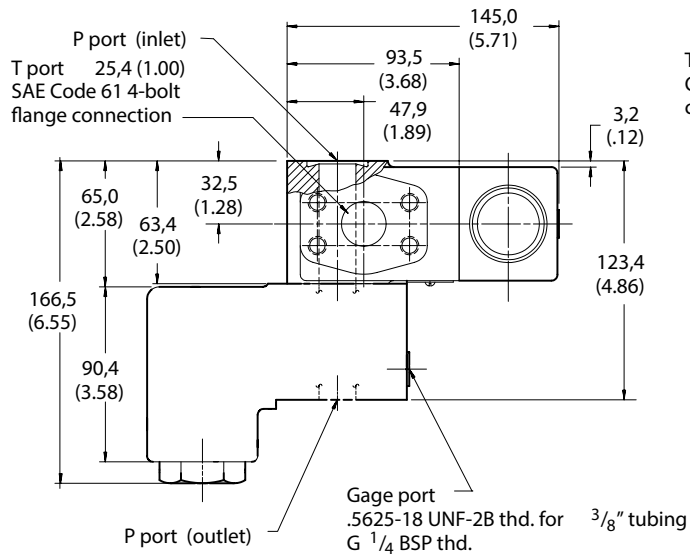

**"CL" Models**  
In-line Check

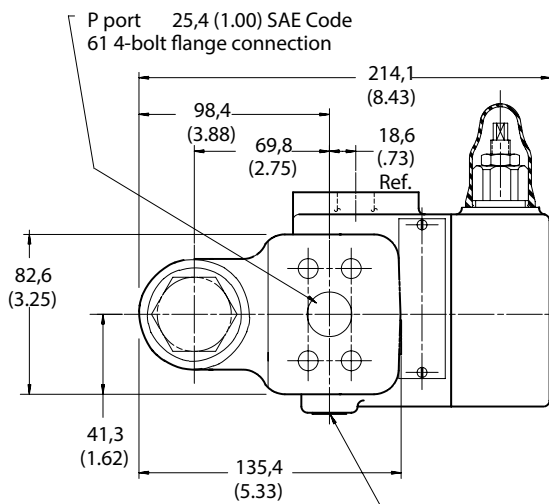
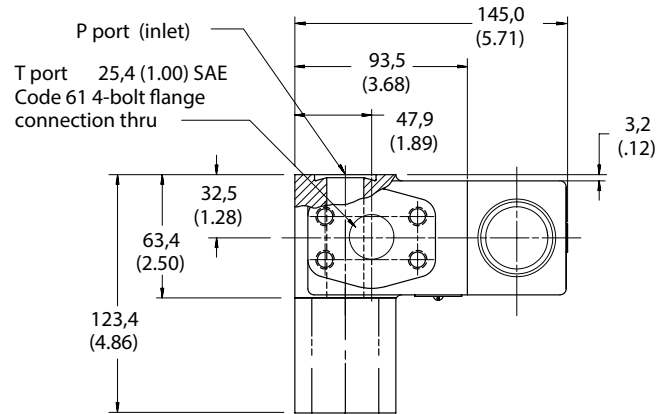

Accumulator pressure gage port  
or external pilot port (models w/o check valve)  
- .5625-18 UNF-2B thd. for 3/8" O.D. tubing  
- G 1/4 BSP thd.

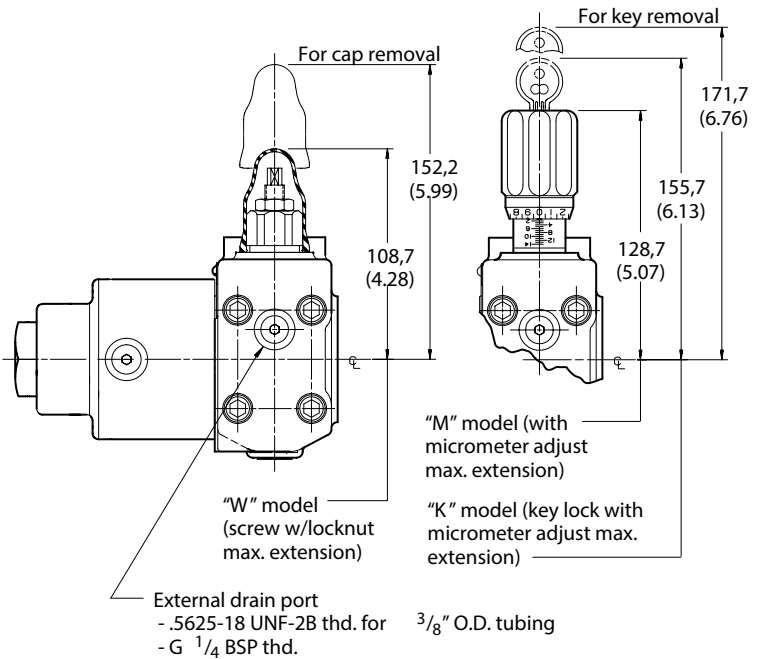

# UPF1S-10 1 1/4" Flange - Unloading Valve Without Vent or Check

mm (inch)

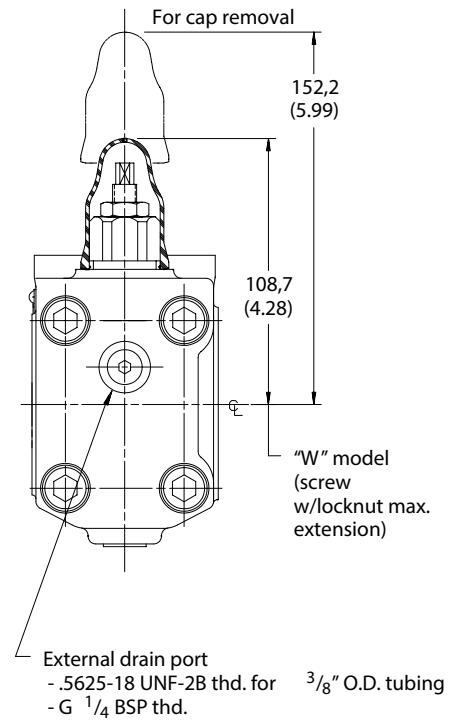
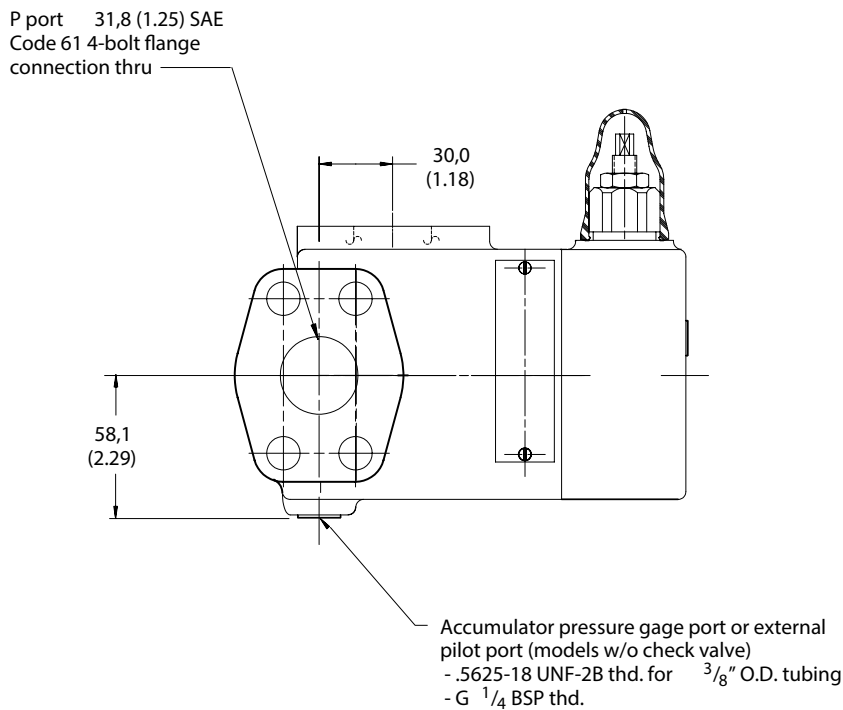
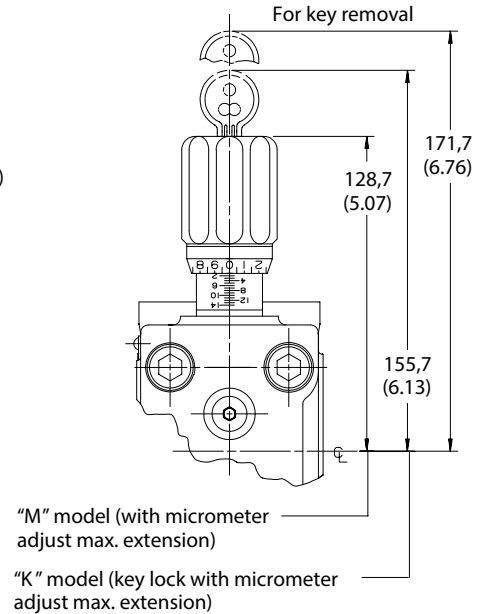
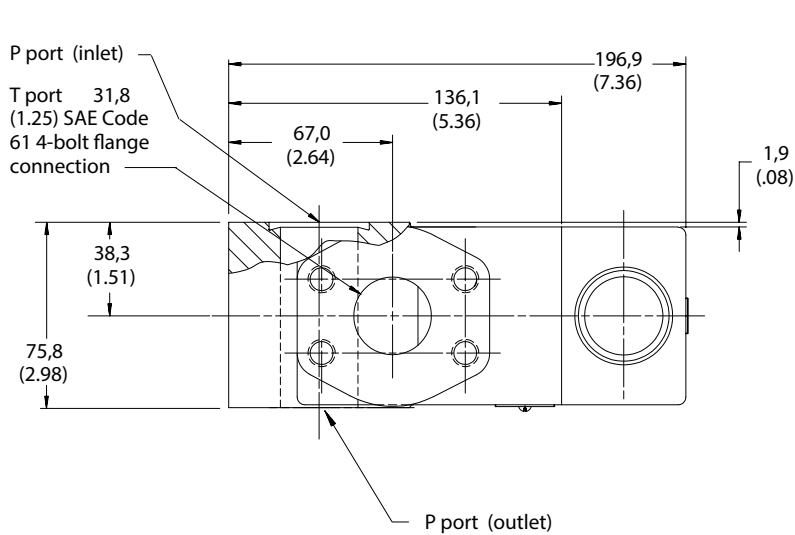

# UPF1S-C\*-10 1 1/4" Flange - Unloading Valve with Check without Vent

mm (inch)

**"C" Models**  
Right Angle Check

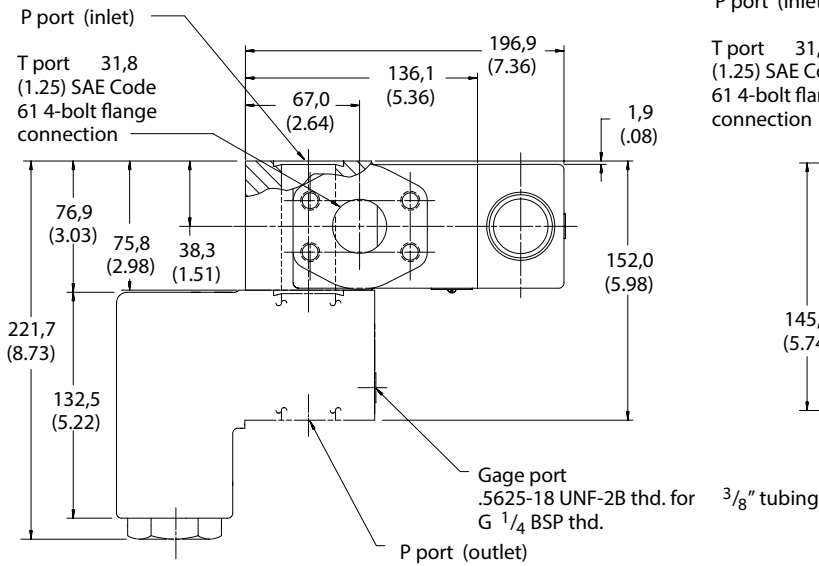

**"CL" Models**  
In-line Check

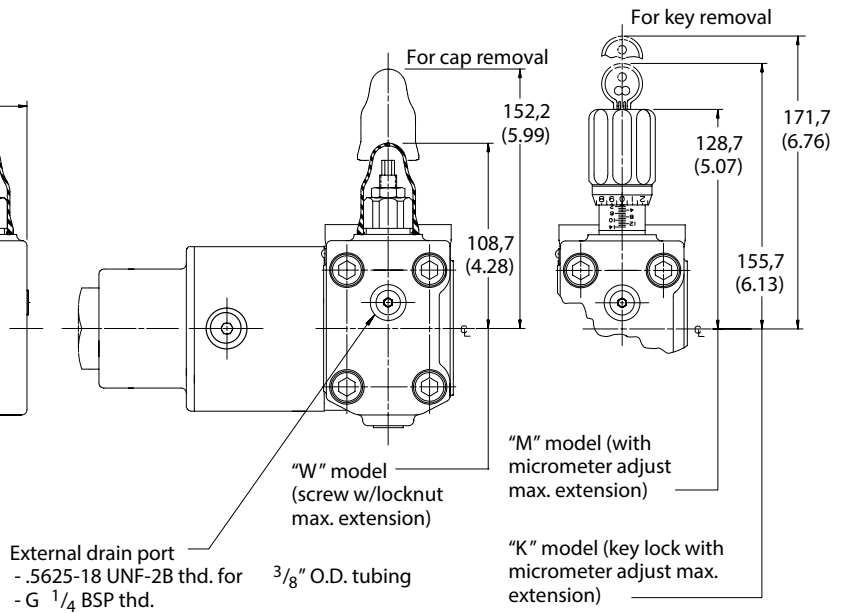
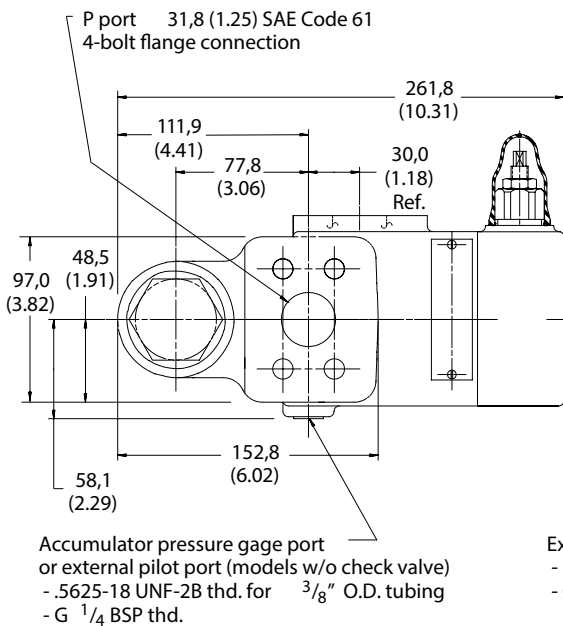
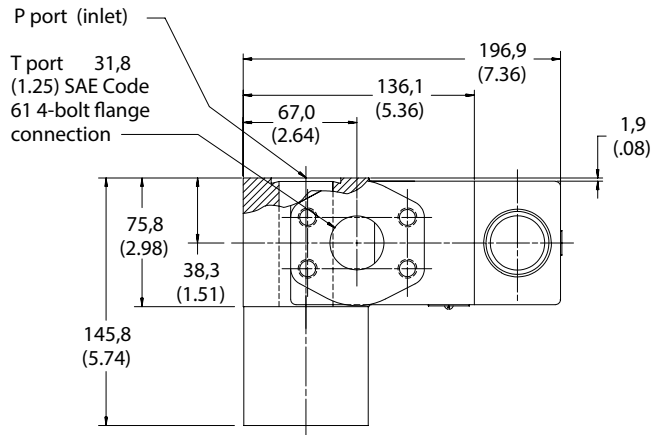

UPF1S-12 – Code 61  
 UPF1V-12 – Code 62  
 1½" Flange -  
 Unloading Valve without Vent or Check

mm (inch)

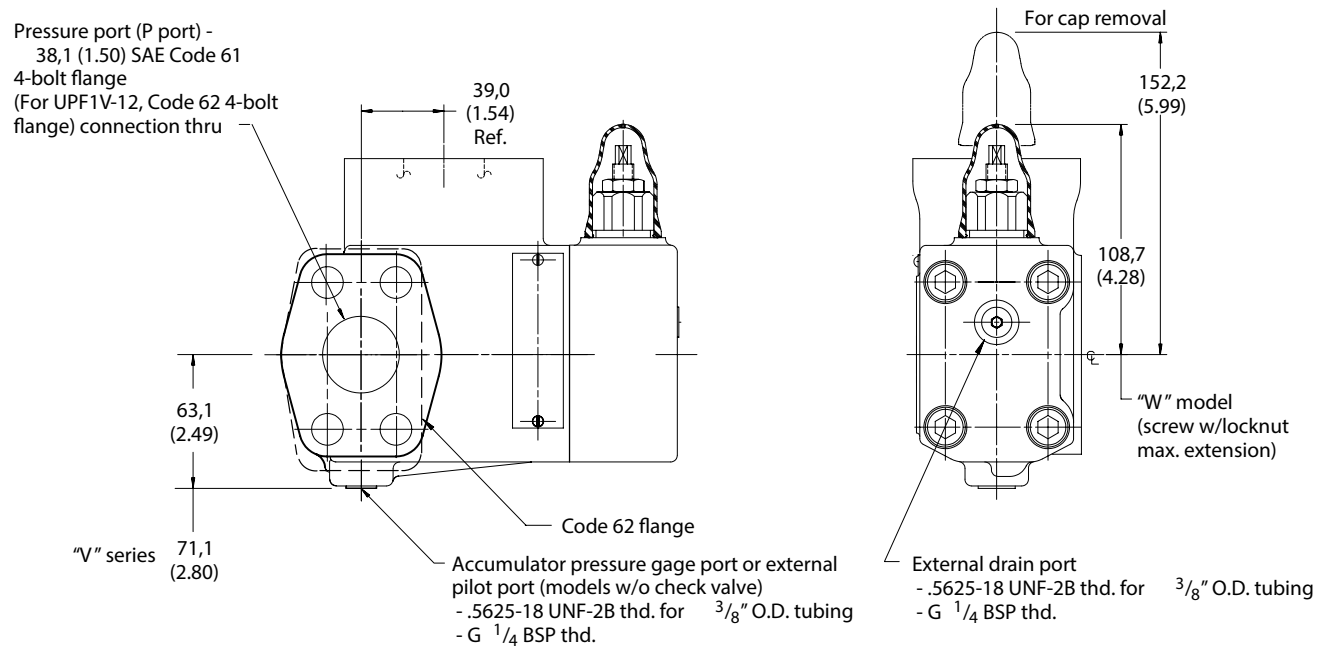
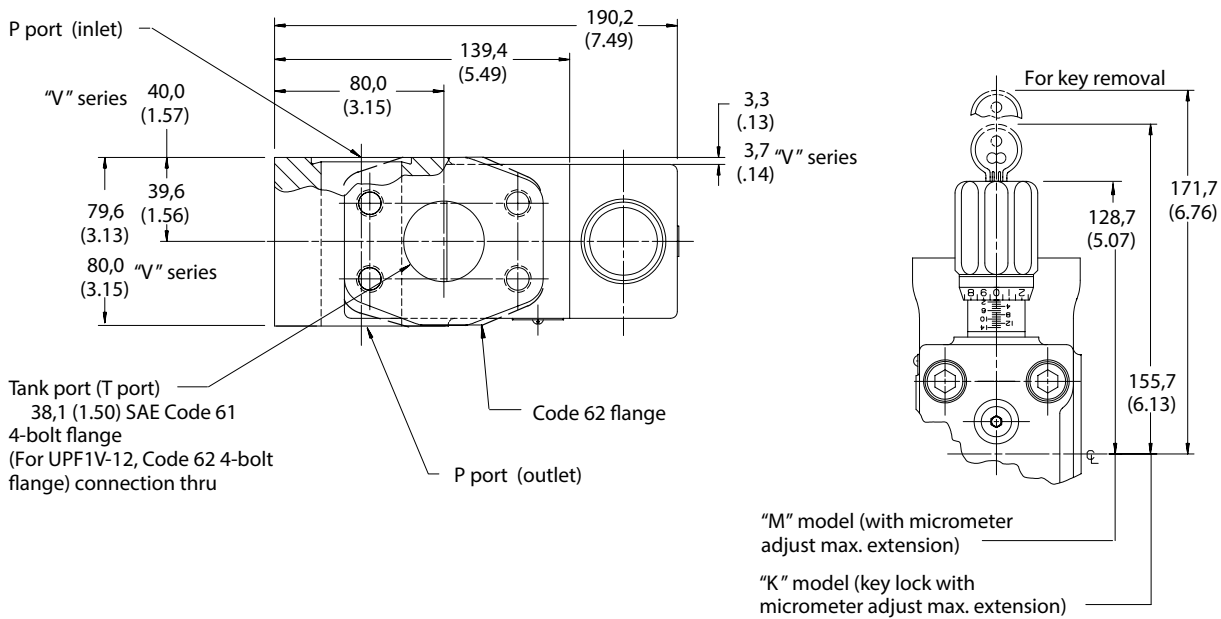

UPF1S-C\*-12 Code 61  
 UPF1V-CL-12 Code 62  
 1 1/2" Flange -  
 Unloading Valve without Vent with Check  
 mm (inch)

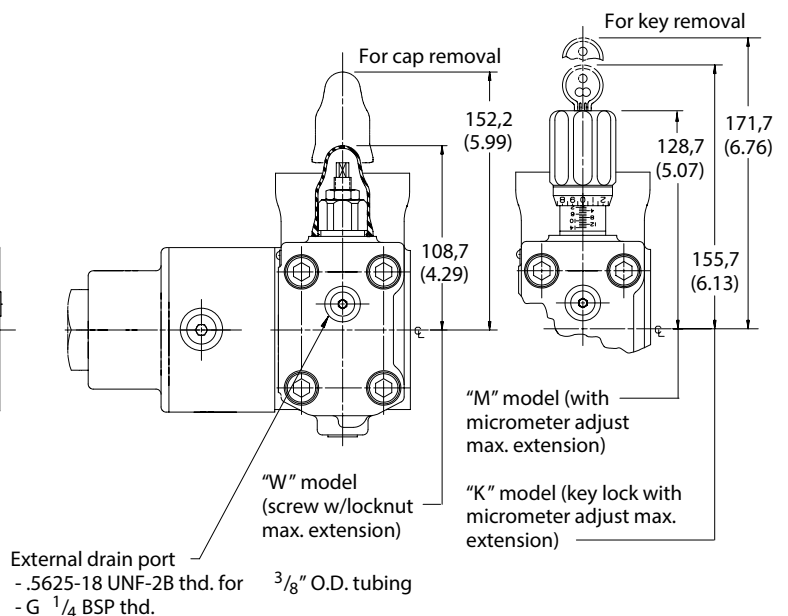
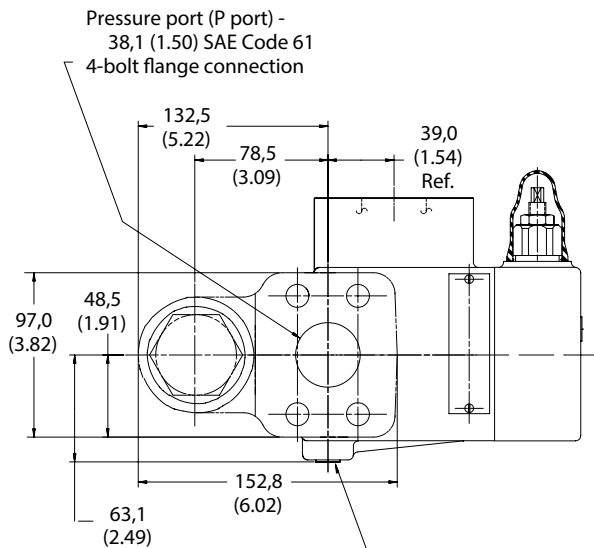
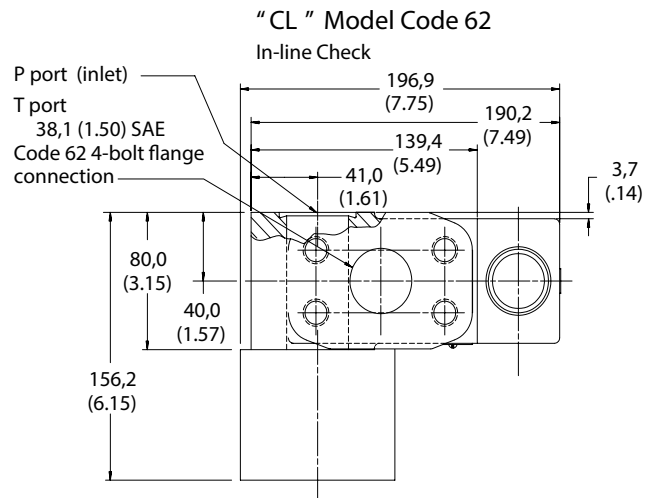
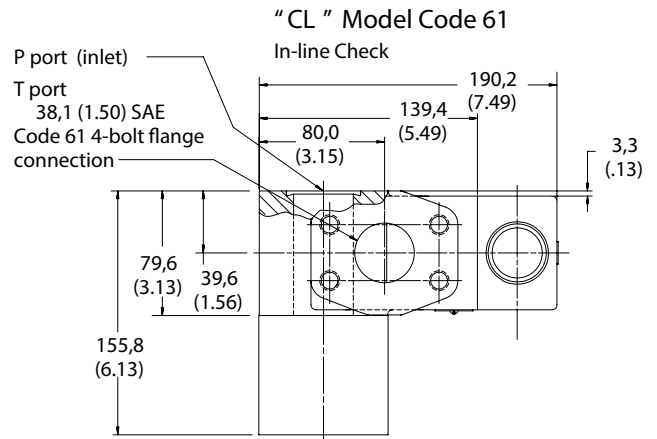
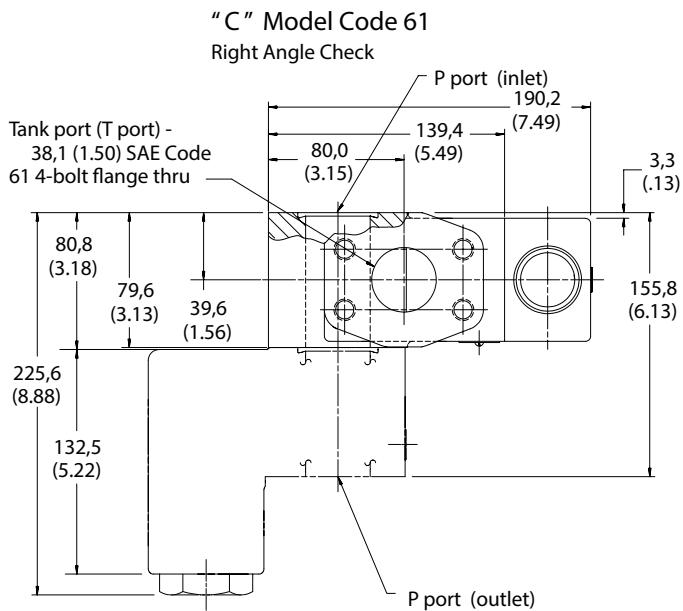

Accumulator pressure gage port or external pilot port (models w/o check valve)  
 - .5625-18 UNF-2B thd. for 3/8" O.D. tubing  
 - G 1/4 BSP thd.

# UPF2\*- (\*\*)- 06/08/10/12-\*\*-20

## Unloading Valves - With Vent

### Flange Sizes

- 06 - 3/4 inch flange
- 08 - 1 inch flange
- 10 - 1 1/4 inch flange
- 12 - 1 1/2 inch flange

### Benefits

- Excellent repeatability and stable performance from cartridge design mainstage parts.
- Reduced installed costs and space requirements.
- Easier installation and servicing of components.
- Pilot design minimizes response time and cracking flow which allows for high pressure stability thus increasing system productivity.
- Direct mounting to pump flange reduces potential leak points for superior leak resistance.

Ratings	UPF2S-06	UPF2S-08	UPF2S-10	UPF2S-12
Maximum flow	100 l/min (26 USgpm)	300 l/min (80 USgpm)	600 l/min (160 USgpm)	600 l/min (160 USgpm)
Maximum pressure:				
P port	275 bar (4000 psi)	275 bar (4000 psi)	275 bar (4000 psi)	275 bar (4000 psi)*
T port	207 bar (3000 psi)	207 bar (3000 psi)	207 bar (3000 psi)	207 bar (3000 psi)

\* The CPF2V-12 (code 62 flange) has a max. P port pressure rating of 350 bar (5000 psi).

### Pilot Valve Max. T Port Pressure Rating

100 bar (1450 psi) for DG4V-3S valve  
 207 bar (3000 psi) for DG4V-3 valve AC  
 207 bar (3000 psi) for DG4V-3 valve DC

### Electrical Response

Electrical response is defined as the time from initiation of power to the solenoid, to the initiation of pressure rise, with 1,5 liters (.4 USgpm) of oil under compression:

06 size –  
 @100 l/min (26 USgpm) = DC - 200 ms  
 AC - 160 ms

08 size –  
 @300 l/min (80 USgpm) = DC - 210 ms  
 AC - 175 ms

10/12 size -  
 @300 l/min (80 USgpm) = DC - 180 ms  
 AC - 160 ms

### Hydraulic Response

06 Size: Rate of pressure rise with 2,5 liters (.7 USgpm) of oil under compression = 3450 bar (50000 psi) /second. Maximum overshoot < 8%.

08 Size: Rate of pressure rise with 2,5 liters (.7 USgpm) of oil under compression = 2900 bar (42000 psi) /second. Maximum overshoot < 10%.

10/12 Sizes: Rate of pressure rise with 2,5 liters (.7 USgpm) of oil under compression = 2600 bar (37500 psi) /second. Maximum overshoot < 10%.

### General Description

This Vickers by Danfoss UPF2S relief valve features flange mounting for increased design flexibility and reduced external piping. The valve is designed for direct mounting on the SAE flange outlet port of a pump. Fewer leak points and SAE flange connections lead to installations with superior leak resistance.

Unloading valves are used in accumulator charging circuits where a pressure regulator is required to automatically unload the pump by diverting the pump delivery to the reservoir, at low pressure, when the

desired accumulator pressure is reached. These valves may also be used to unload the low pressure side of double pumps. The unloading valves also function as pressure relief valves when the remote pressure is lower than the plunger pressure setting. The UPF2S valve has excellent dynamic and steady state operating characteristics including stability, fast response and low pressure override.

UPF valves are of two-stage design with a fast-acting poppet type main stage for simple, long-lasting and effective operation. The many available

control options make it possible to choose the optimum valve model for each application.

In construction, an unloading valve contains a compound relief valve with a poppet-type main stage, a check valve to prevent reverse flow from the accumulator, and a pressure operated plunger, which vents the relief valve at the selected pressure.

# UPF2\* Model Series

## Model Code

**UPF2\* - (\*\*) - \*\* - \* - \* - (B) - (P) - (1) - 3(S)(\*) (V) M- (S\*) - \*\*\* (L) - \* \* - 20**

1 2 3 4 5 6 7 8 9 10 11 12 13 14 15 16 17 18 19 20 21

<p><b>1</b> Valve Function</p> <p>U - Unloading valve</p>	<p><b>7</b> Pressure Adjustment Range</p> <p>A - 9 - 70 bar (130 - 1000 psi)            B - 9 - 125 bar (130 - 1800 psi)            F - 9 - 245 bar (130 - 3600 psi)            G - 9 - 275 bar (130 - 4000 psi)            350 bar (5000 psi) - (UPF2V-12 models only)</p>	<p><b>13</b> Manual Override Options</p>
<p><b>2</b> Mounting Type</p> <p>PF - Pump flange mounting</p>	<p><b>8</b> Control Type</p> <p>W - Screw adjust with locknut            K - Micrometer adjust with keylock            M - Micrometer adjust w/o keylock</p>	<p><b>14</b> Solenoid Energization Identification</p>
<p><b>3</b> Unit Type</p> <p>2 - Single pressure with vent</p>	<p><b>9</b> Thread Type (remote control/vent connection)</p> <p>Blank - SAE-6 O-ring boss port (.5625-18 UNF-2B thd.)            B - BSP-G 1/4 (1/4" BSPF)</p>	<p><b>15</b> Electrical Options Flag</p>
<p><b>4</b> Flange Type</p> <p>S - SAE J518 4-bolt flange standard series code 61 (available all sizes)            V - SAE J518 4-bolt high pressure series code 62 (size 12 only)</p>	<p><b>10</b> Accumulator Sense Port</p> <p>Blank - Internal sense port            P - External sense port (not available w/check models)</p>	<p><b>16</b> Spool Position Monitoring Switch</p>
<p><b>5</b> Integral Check Valve* (0,3 bar (5 psi) cracking pressure only)</p> <p>Blank - Without right angle check            C - With right angle check - Not available with UPF2V-12            CL - In-line check</p>	<p><b>11</b> Pilot Drain</p> <p>Blank - Internal drain            1 - External drain</p>	<p><b>17</b> Solenoid Type/Electrical Connections</p>
<p><b>6</b> Valve Size</p> <p>06 - 3/4 inch            08 - 1 inch            10 - 1 1/4 inch            12 - 1 1/2 inch</p>	<p><b>12</b> Vent Valve</p> <p>3S - Standard performance            3 - High performance            Uses 22A type spool/spring; other features are optional. Refer to Vickers by Danfoss literature # GB-C-2015B Solenoid Operated Directional Control Valves catalog.</p>	<p><b>18</b> Indicator Lights</p>
		<p><b>19</b> Coil Voltage Identification</p>
		<p><b>20</b> Tank Rating Pressure</p> <p>2 - 10 bar (145 psi) for spool position indicator models.            5 - 100 bar (1450 psi) for standard performance models, DG4V-3S, with AC or DC solenoids.            6 - 207 bar (3000 psi) for high performance models, DG4V-3, with AC solenoids.            7 - 207 bar (3000 psi) for high performance models, DG4V-3 with DC solenoids.</p>
		<p><b>21</b> Design Number, 20 Series</p> <p>Subject to change. Installation dimensions unaltered for design numbers 20 to 29 inclusive.</p>

\* The integral check valve is not the same as the DCPFS right angle check valve.

# Circuit Schematics

UPF2S-C\*-06/08-\*-20 with check valve and vent

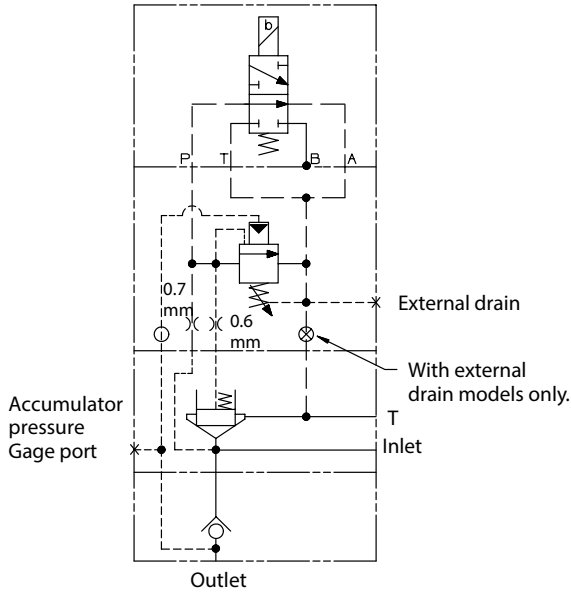

UPF2S-06/08-(P)-\*-20 with vent and without check valve

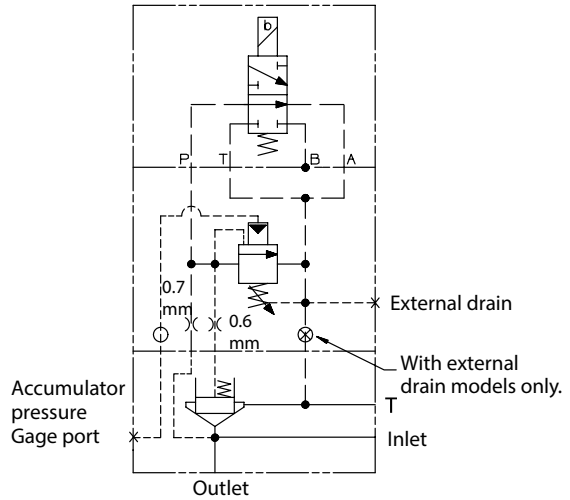

-06 size 100 l/min (26 USgpm) max. flow  
 -08 size 300 l/min (80 USgpm) external drain  
 150 l/min (40 USgpm) internal drain max. flow

UPF2S-C\*-10/12-\*-20 with check valve and vent

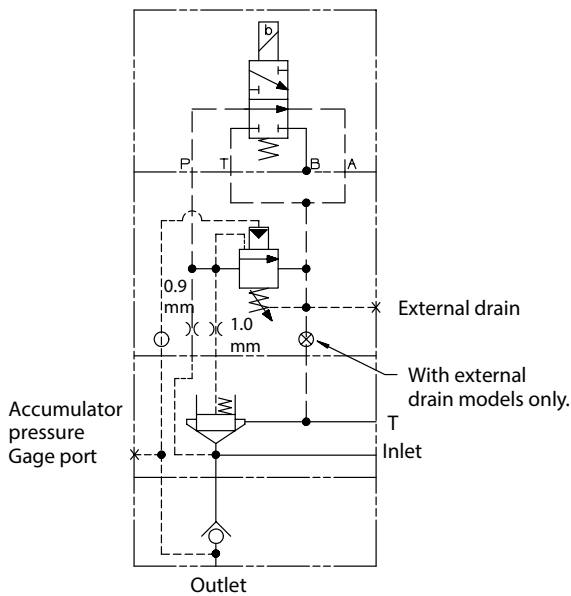

UPF2S-10/12-(P)-\*-20 with vent and without check valve

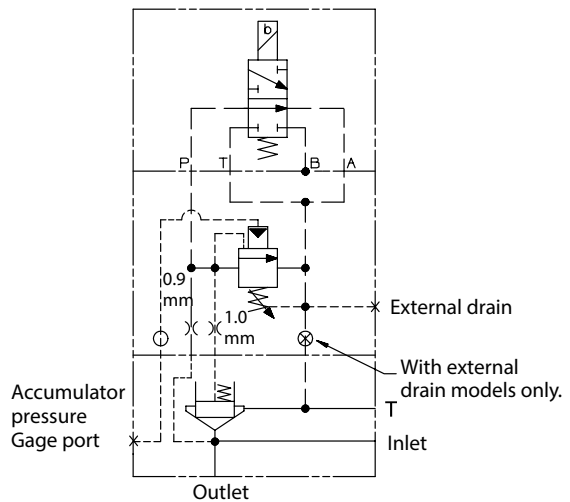

-10/-12 sizes 600 l/min (160 USgpm) max. flow



# Pressure Curves

## UPF2S-06

Unload vs Recharge P Pressure @100 l/min  
(26 USgpm) with integral check valve as supplied.

Internal Drain ———  
External Drain - - - -

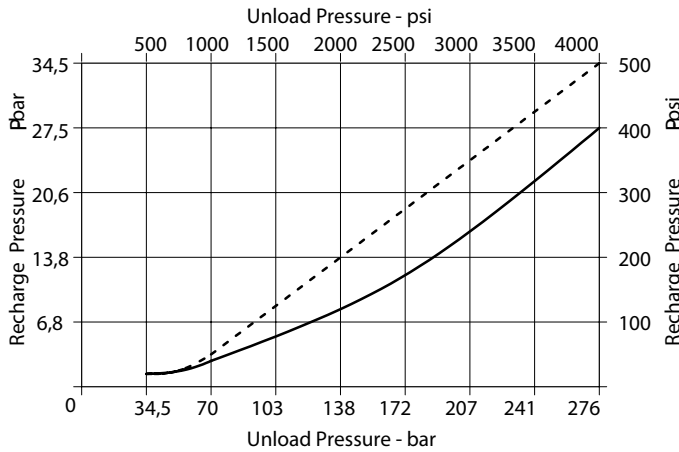

## Vented P P to T

Internal Drain ———  
External Drain - - - -

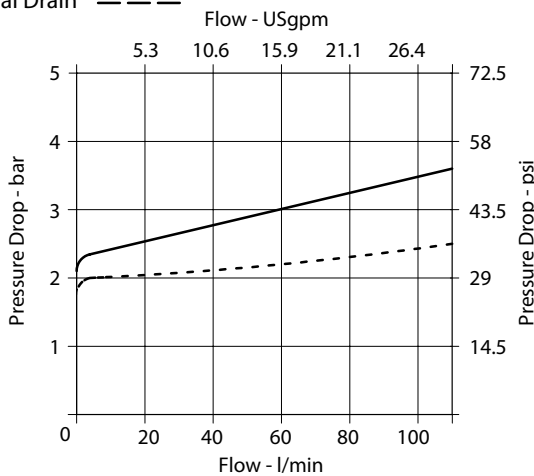

## P P to P

With 0,3 bar (5 psi) Check Valve

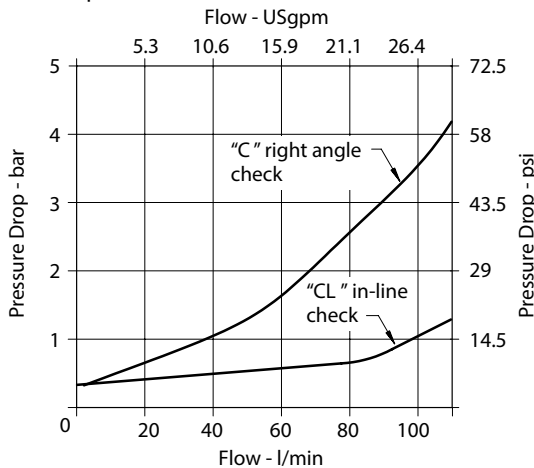

## UPF2S-08

Unload vs Recharge P Pressure with integral check valve as supplied.

Internal Drain ——— @150 l/min (40 USgpm)  
External Drain - - - - @300 l/min (80 USgpm)

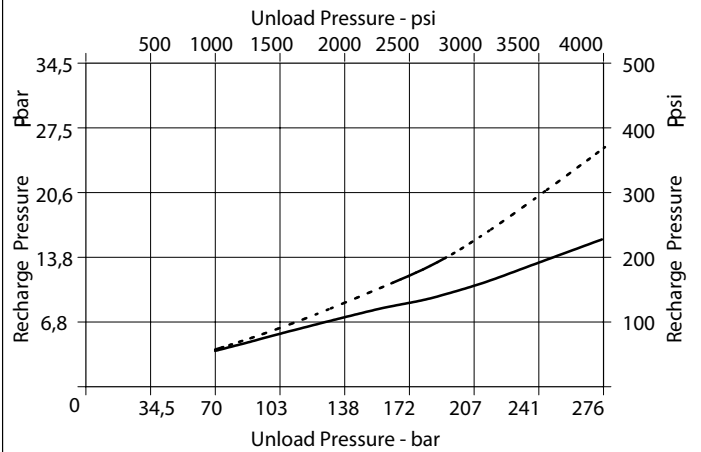

## Vented P P to T

Internal Drain ———  
External Drain - - - -

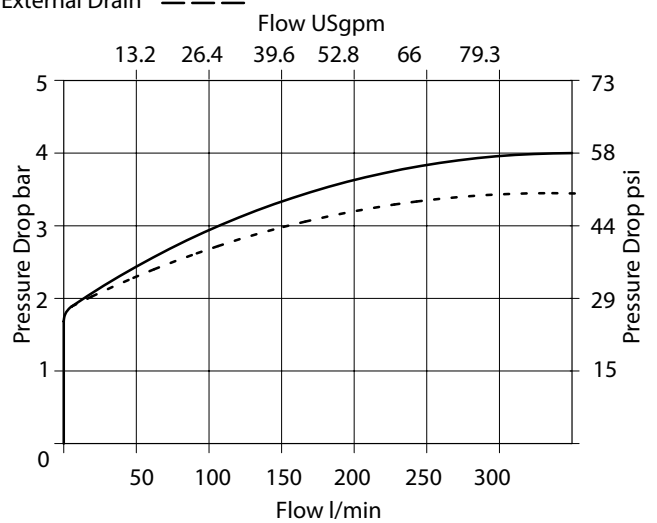

## P P to P

With 0,3 bar (5 psi) Check Valve

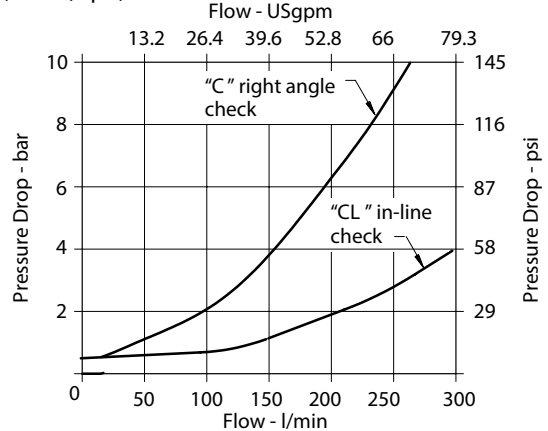

**UPF2S-10**

Unload vs Recharge P Pressure with integral check valve as supplied.

Internal Drain — @600 l/min (160 USgpm)  
 External Drain - - - @600 l/min (160 USgpm)

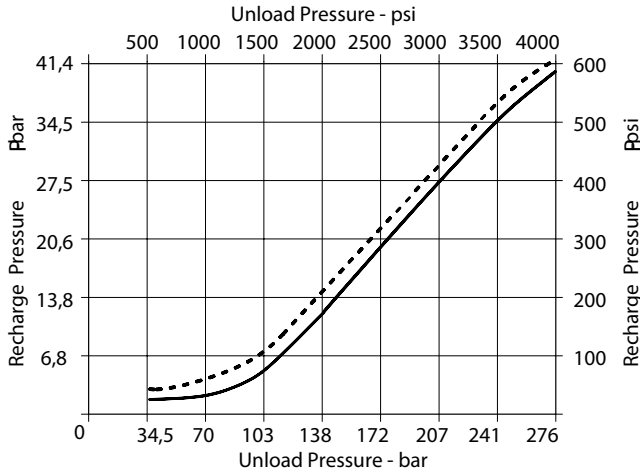

Vented P P to T

Internal Drain — @600 l/min (160 USgpm)  
 External Drain - - - @600 l/min (160 USgpm)

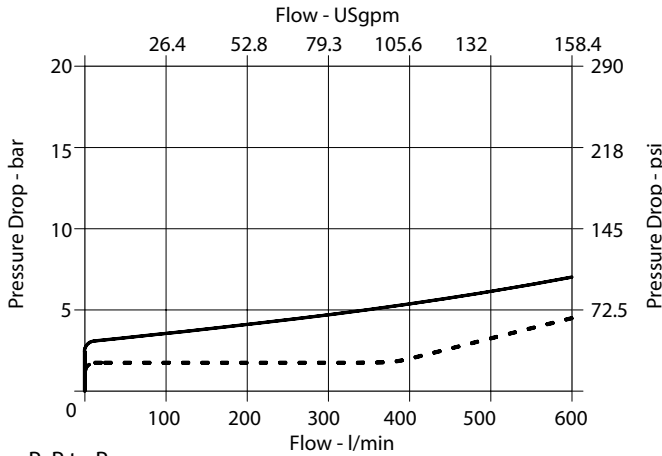

P P to P  
 With 0,34 bar (5 psi) Check Valve

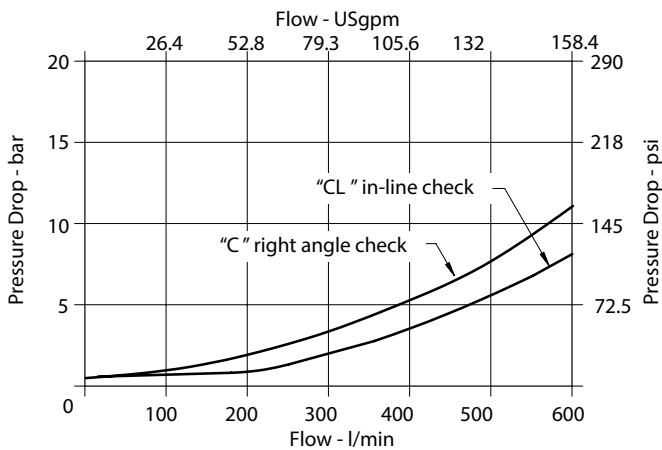

**UPF2S(V)-12**

Unload vs Recharge P Pressure with integral check valve as supplied.

Internal Drain — @600 l/min (160 USgpm)  
 External Drain - - - @600 l/min (160 USgpm)

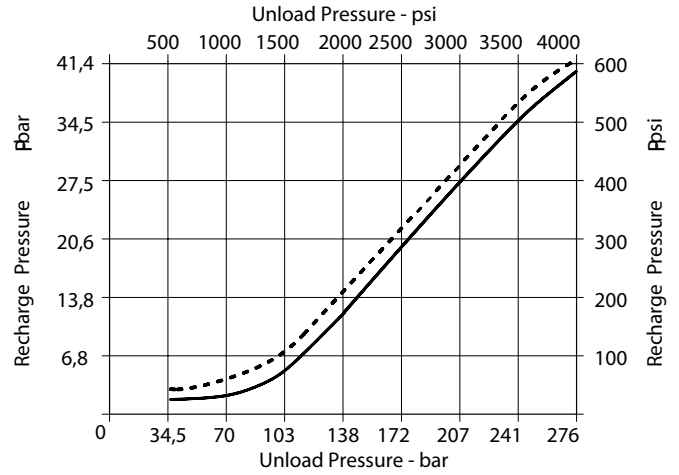

Vented P P to T

Internal Drain — @600 l/min (160 USgpm)  
 External Drain - - - @600 l/min (160 USgpm)

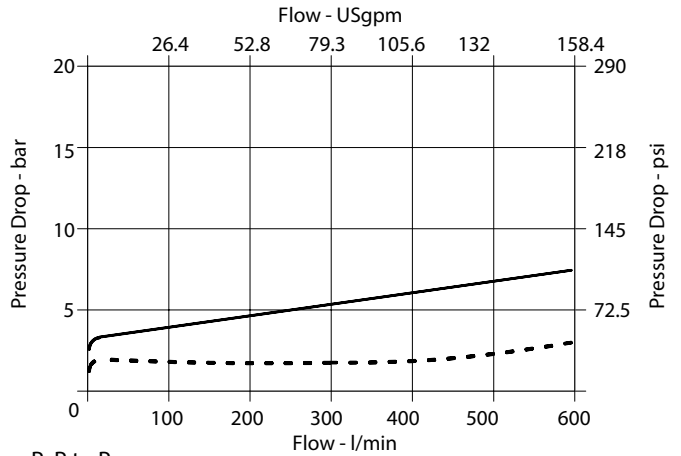

P P to P  
 With 0,34 bar (5 psi) Check Valve

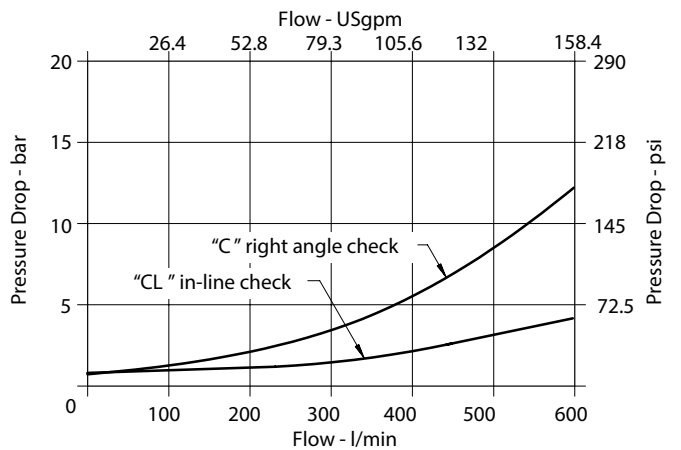

# Installation Dimensions

## UPF2S-06 3/4" Flange - Unloading with Vent without Check

mm (inch)

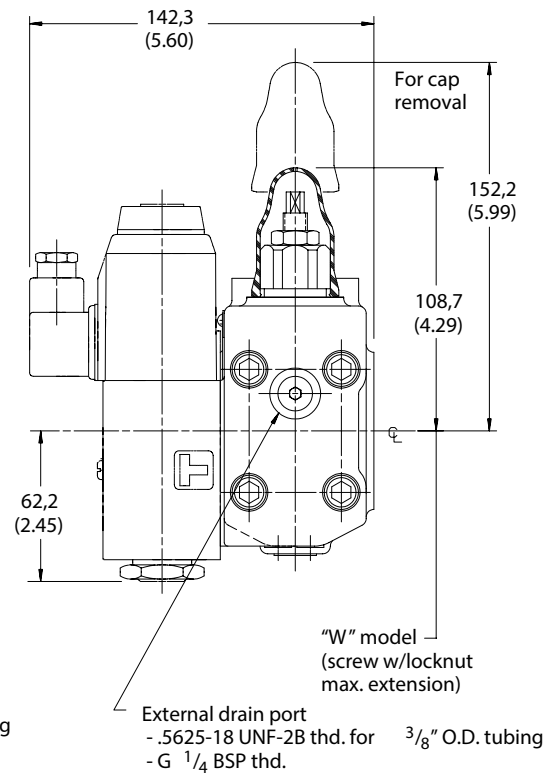
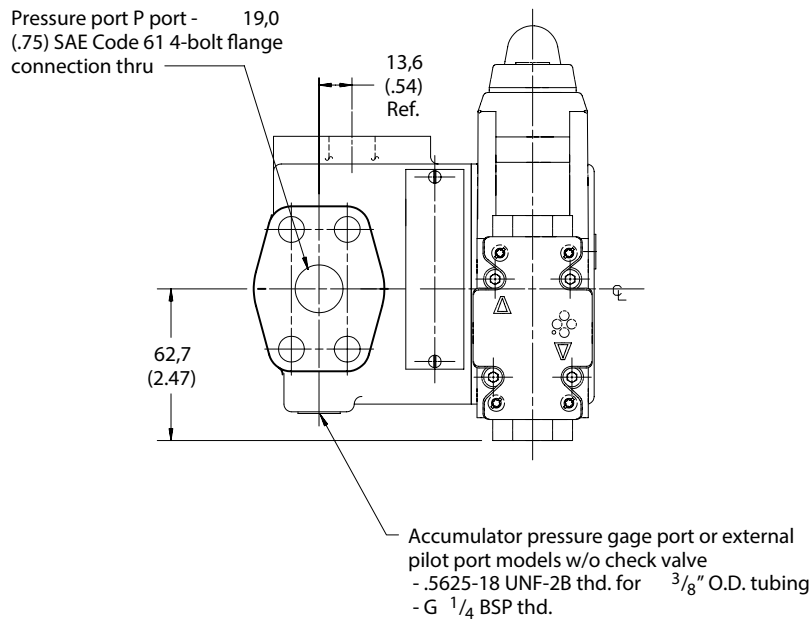
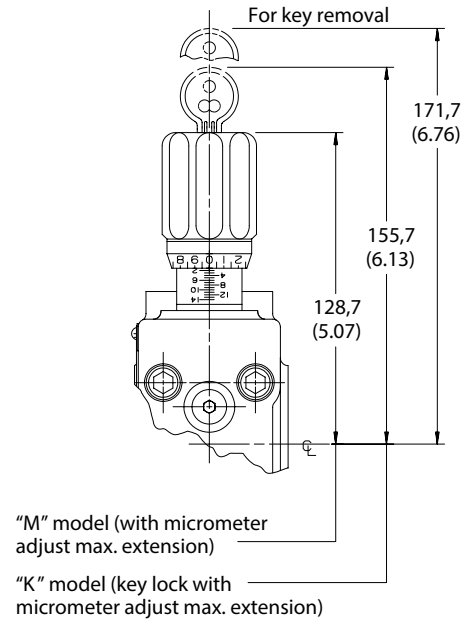
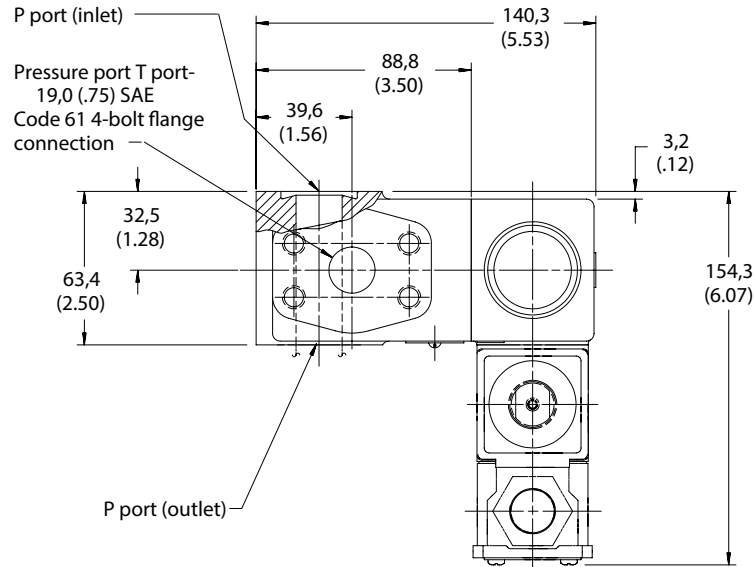



UPF2S-08  
 1" Flange -  
 Unloading with Vent without Check

mm (inch)

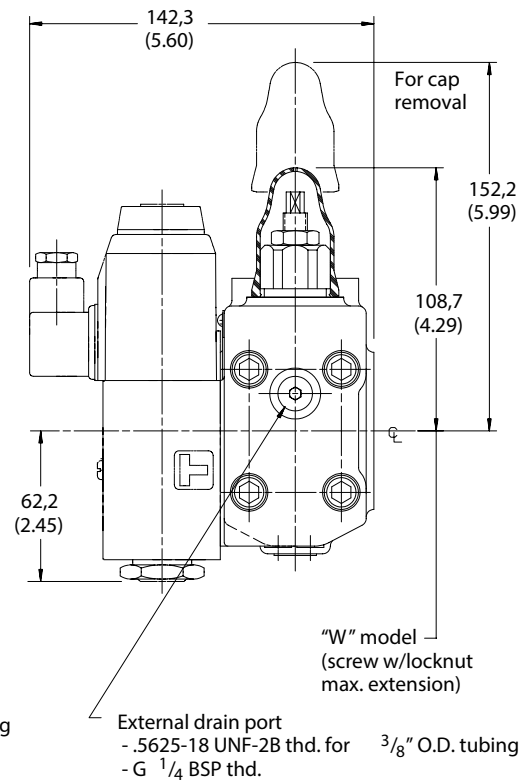
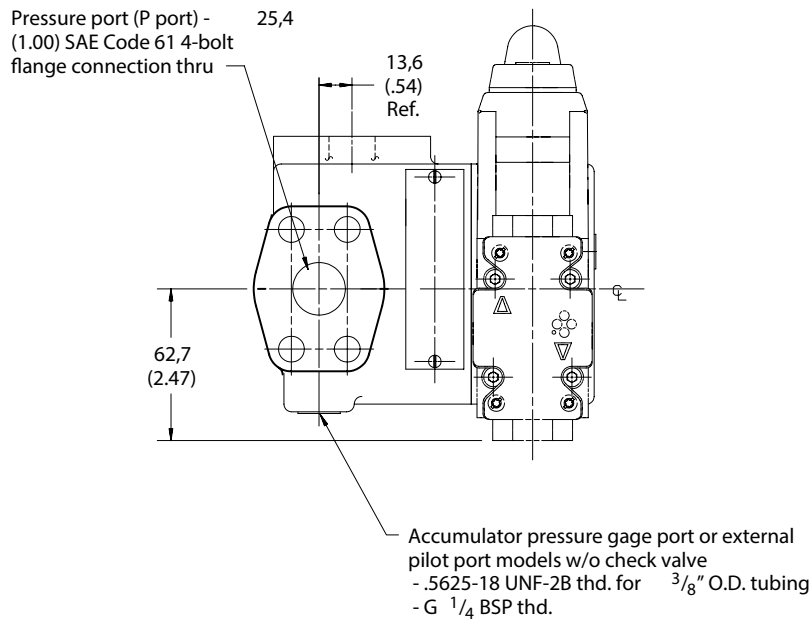
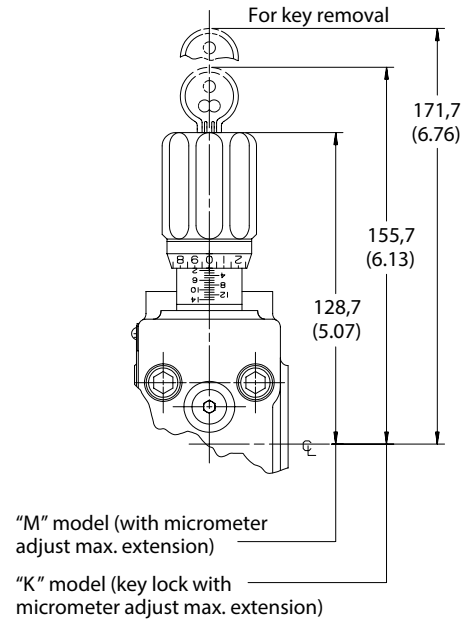
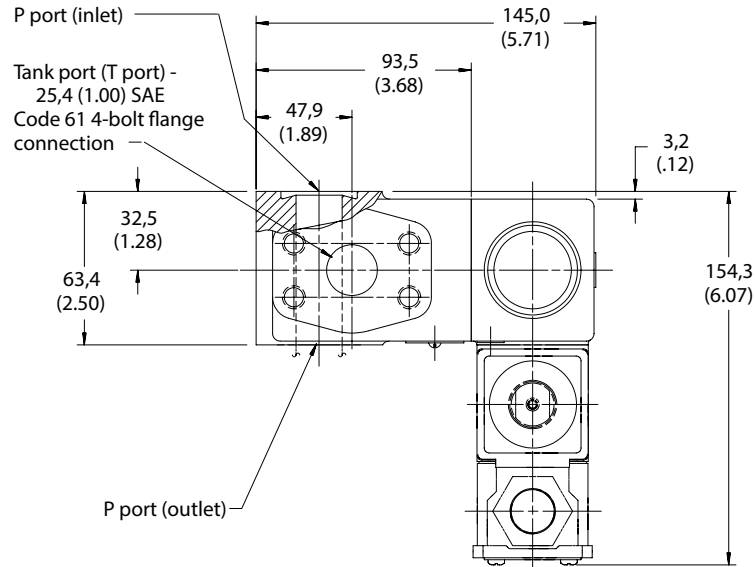

UPF2S-C\*-08  
 1" Flange -  
 Unloading with Vent & Check  
 mm (inch)

"C" Models  
 Right Angle Check

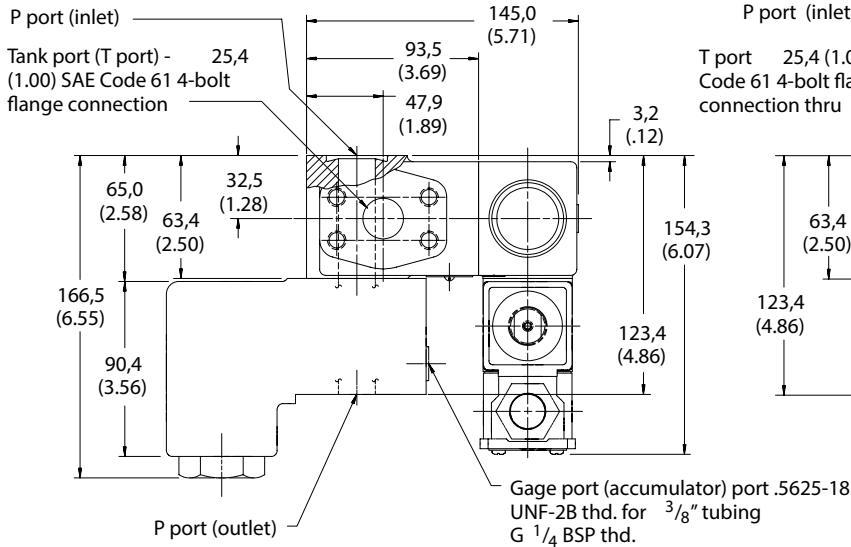

"CL" Models  
 In-line Check

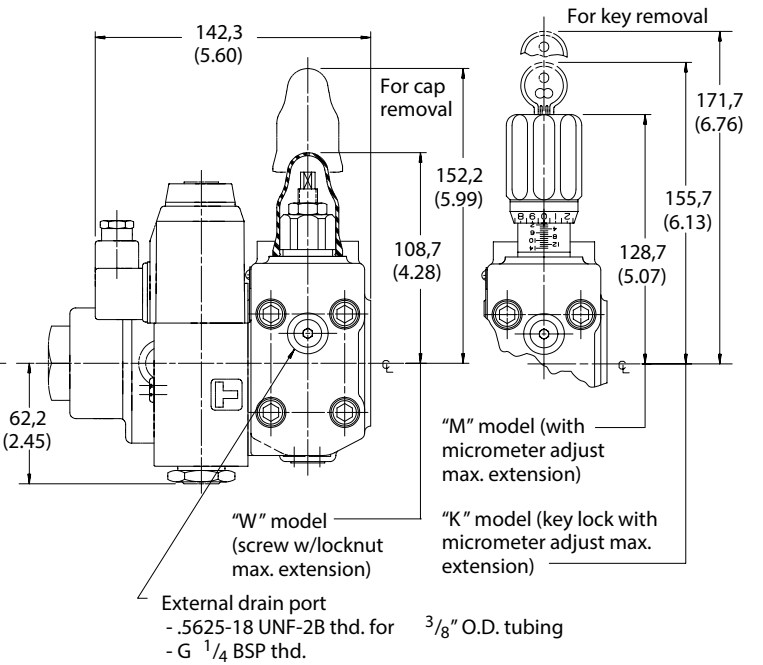
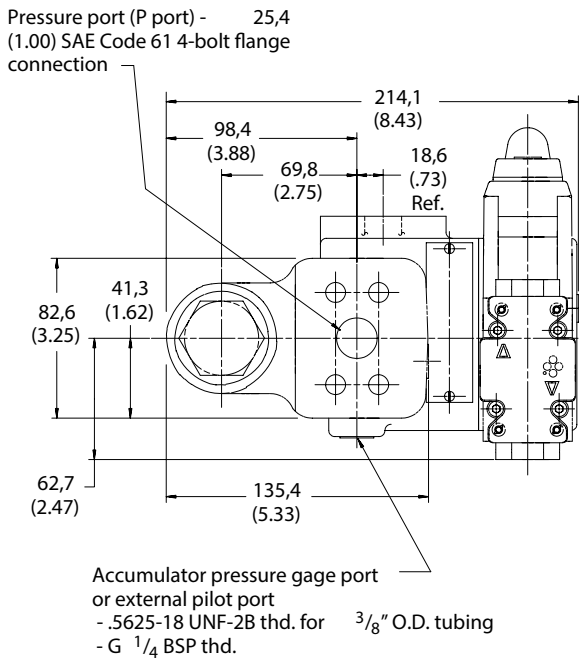
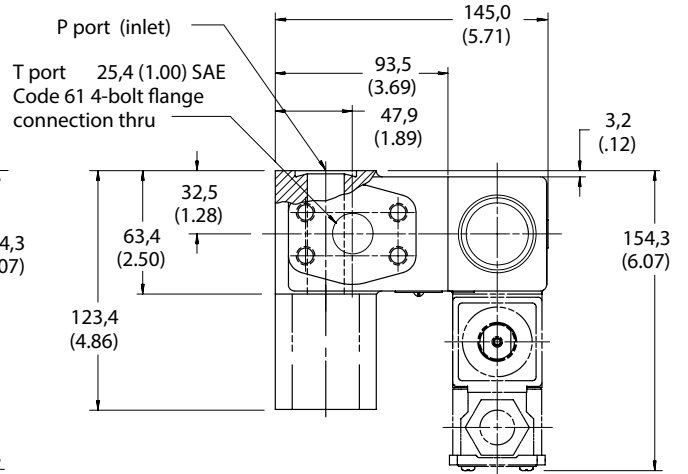

UPF2S-10  
 1 1/4" Flange -  
 Unloading with Vent without Check

mm (inch)

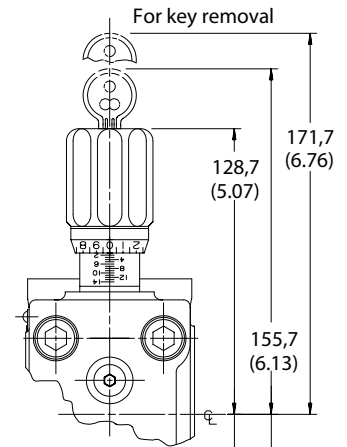
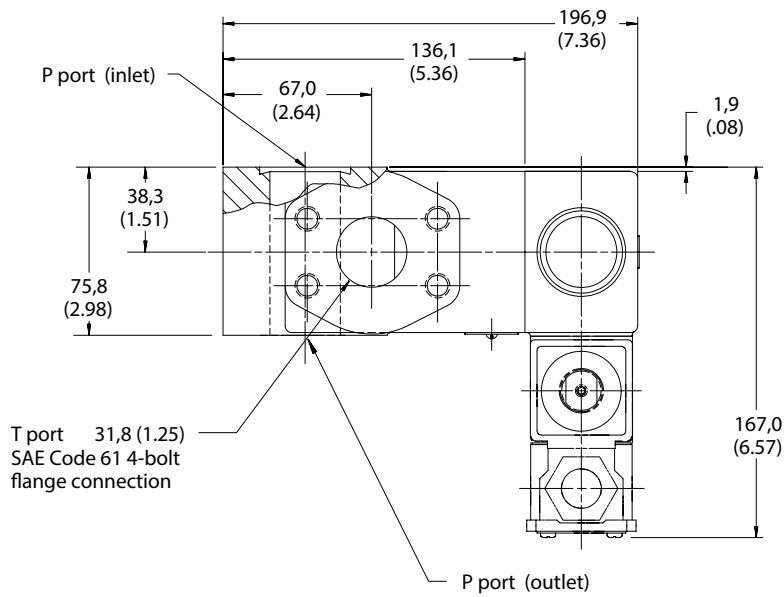

"M" model (with micrometer adjust max. extension)

"K" model (key lock with micrometer adjust max. extension)

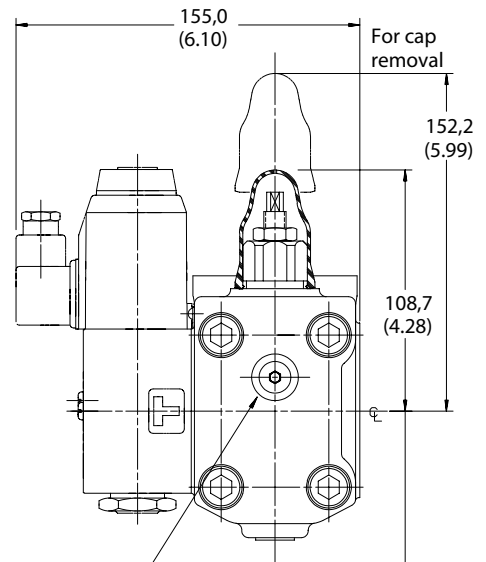
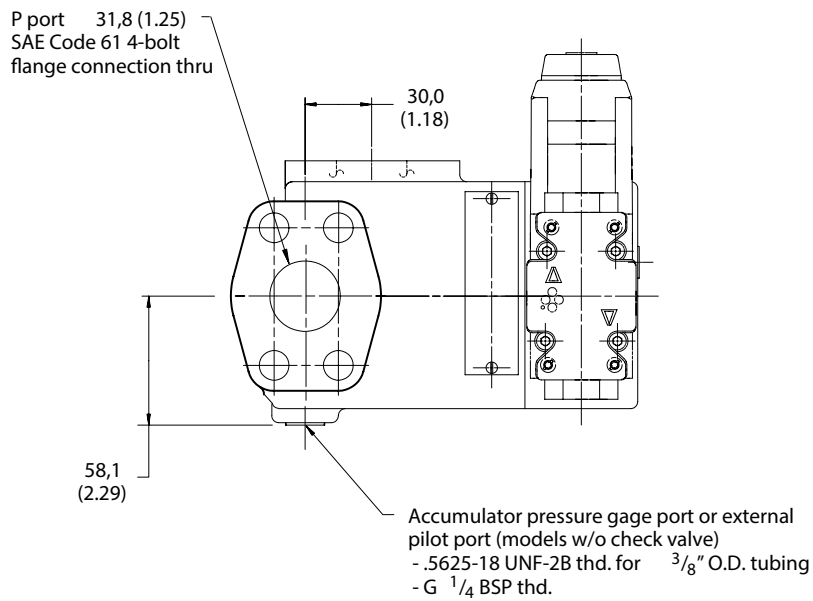

"W" model (screw w/locknut max. extension)

External drain port  
 - .5625-18 UNF-2B thd. for 3/8" O.D. tubing  
 - G 1/4 BSP thd.

UPF2S-C\*-10  
 1 1/4" Flange -  
 Unloading with Vent & Check

mm (inch)

"C" Models  
 Right Angle Check

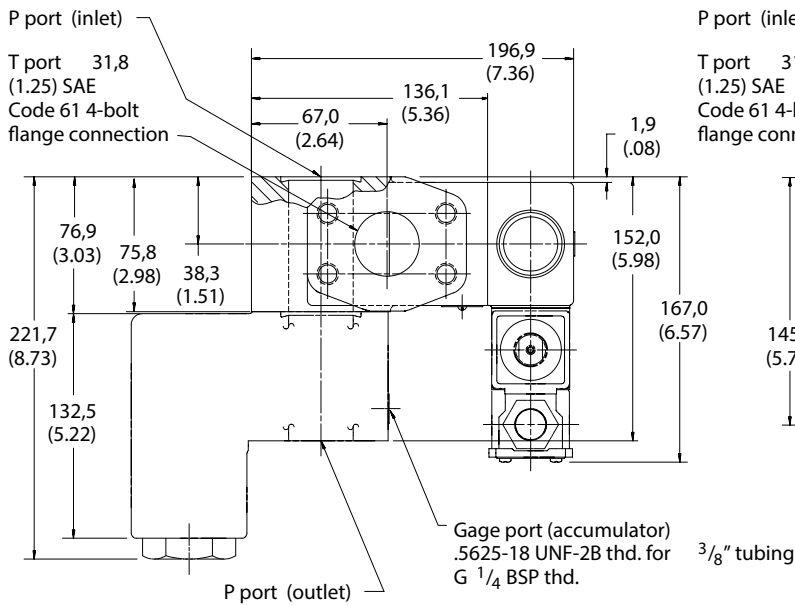

"CL" Models  
 In-line Check

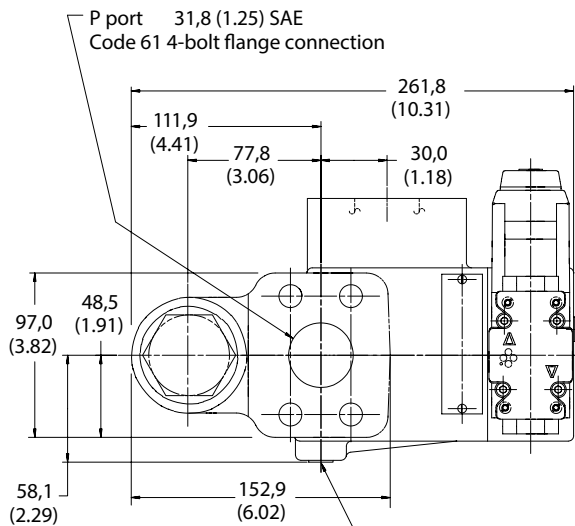
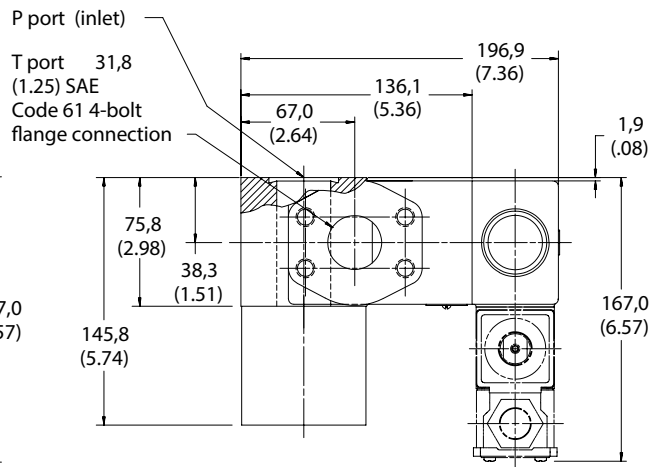

Accumulator pressure gage port or external pilot port  
 - .5625-18 UNF-2B thd. for 3/8" O.D. tubing  
 - G 1/4 BSP thd.

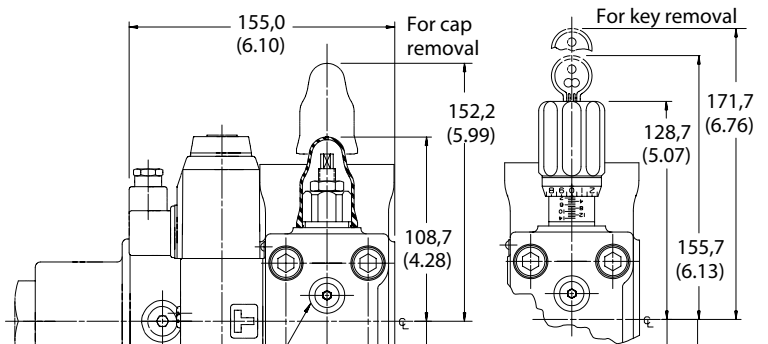

"M" model (with micrometer adjust max. extension)

"K" model (key lock with micrometer adjust max. extension)

"W" model (screw w/locknut max. extension)  
 External drain port  
 - .5625-18 UNF-2B thd. for 3/8" O.D. tubing  
 - G 1/4 BSP thd.



UPF2S-12 – Code 61  
 UPF2V-12 – Code 62  
 1 1/2" Flange -  
 Unloading with Vent without Check

mm (inch)

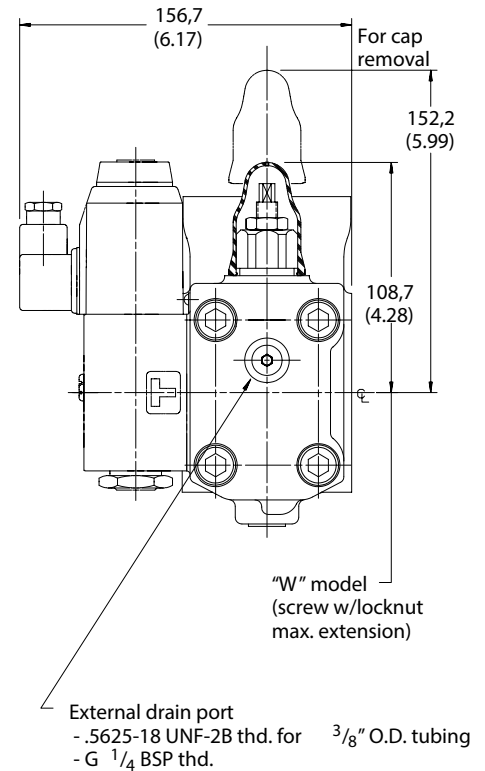
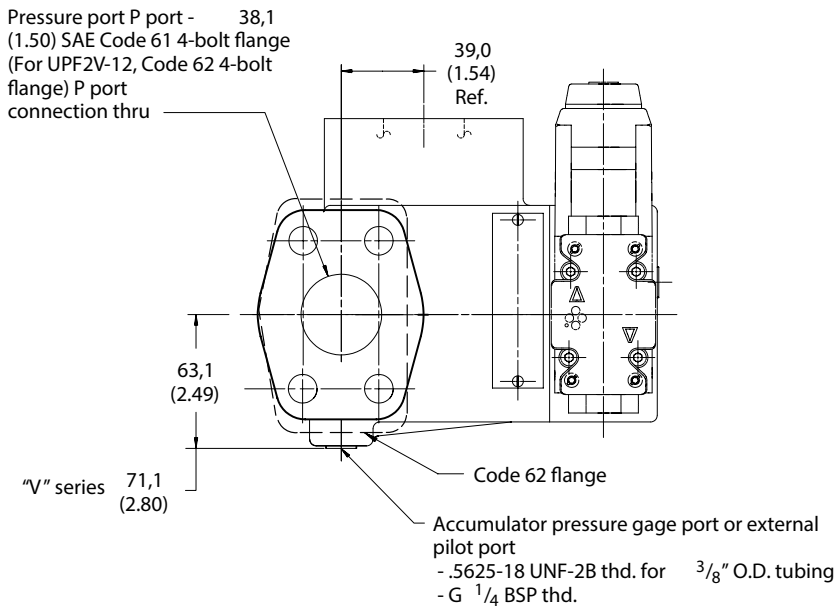
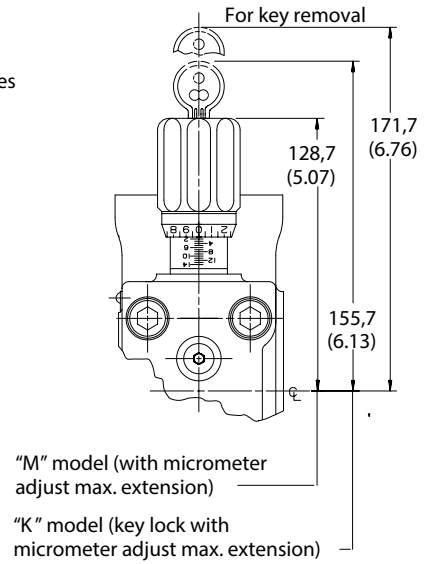
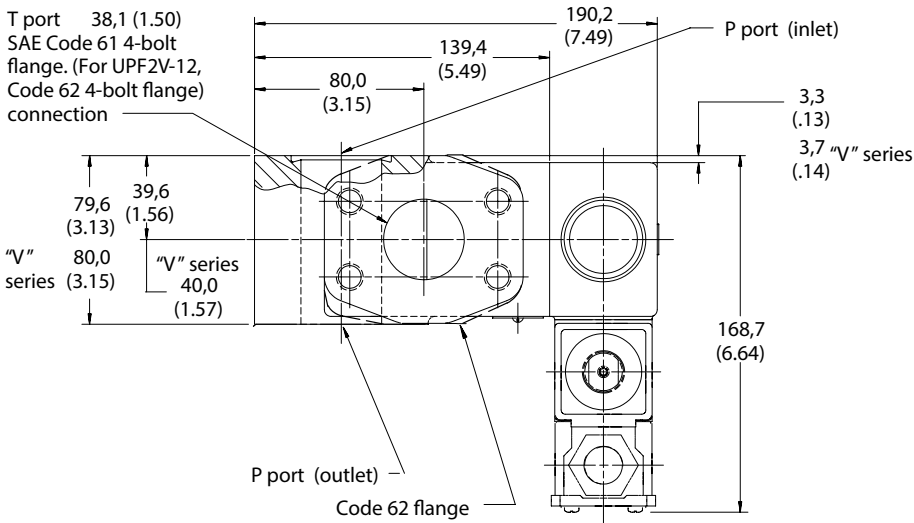

UPF2S-C\*-12 Code 61  
 UPF2V-CL-12 Code 62  
 1½" Flange -  
 Unloading with Vent & Check  
 mm (inch)

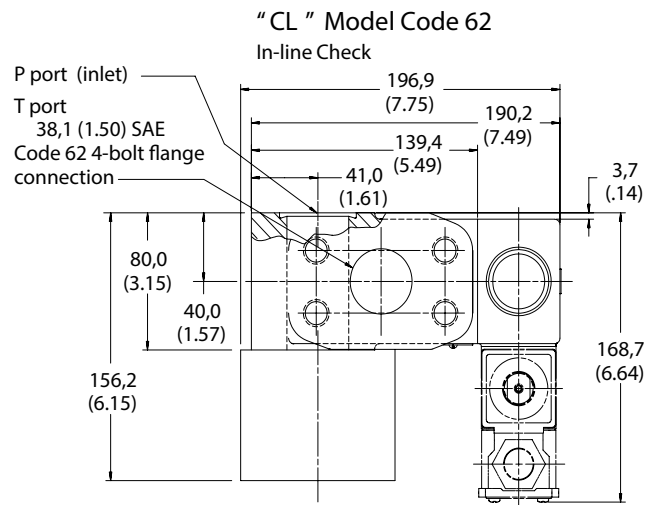
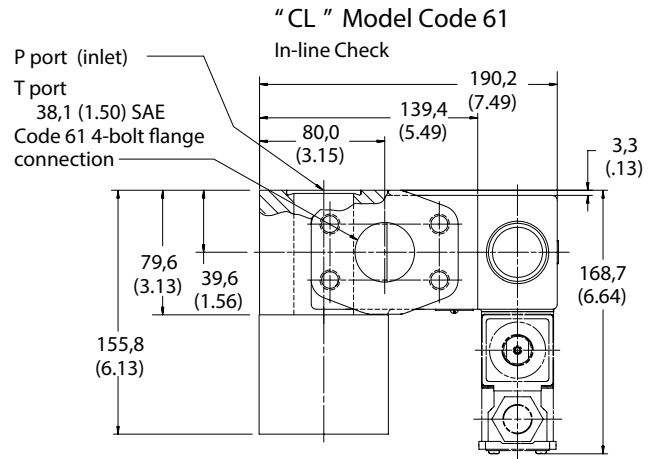
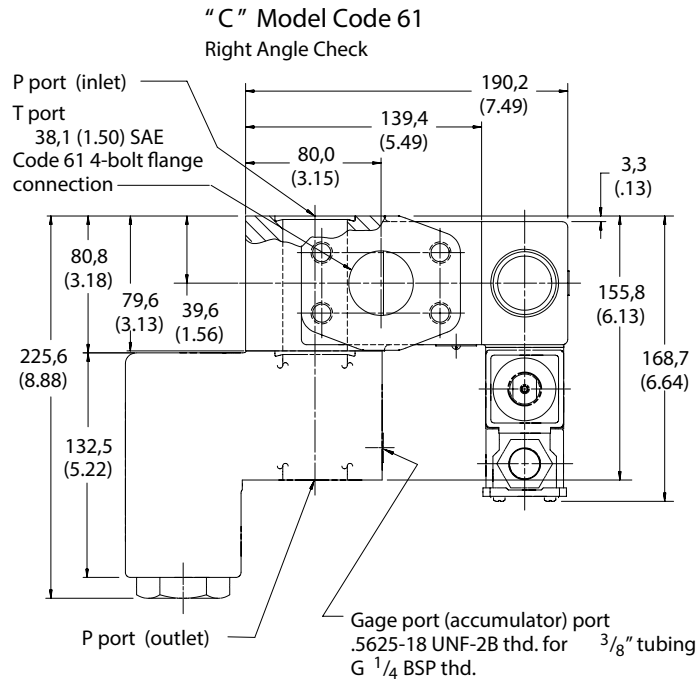

Pressure Port (P port)  
 38,1 (1.50) SAE Code  
 61 4-bolt flange  
 connection

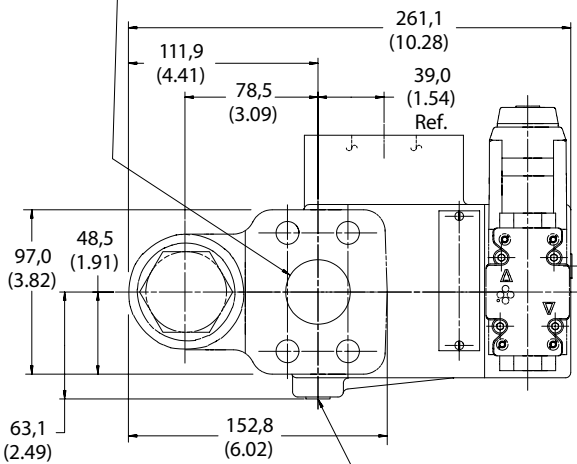

Accumulator pressure gage port  
 or external pilot port  
 - .5625-18 UNF-2B thd. for 3/8" O.D. tubing  
 - G 1/4 BSP thd.

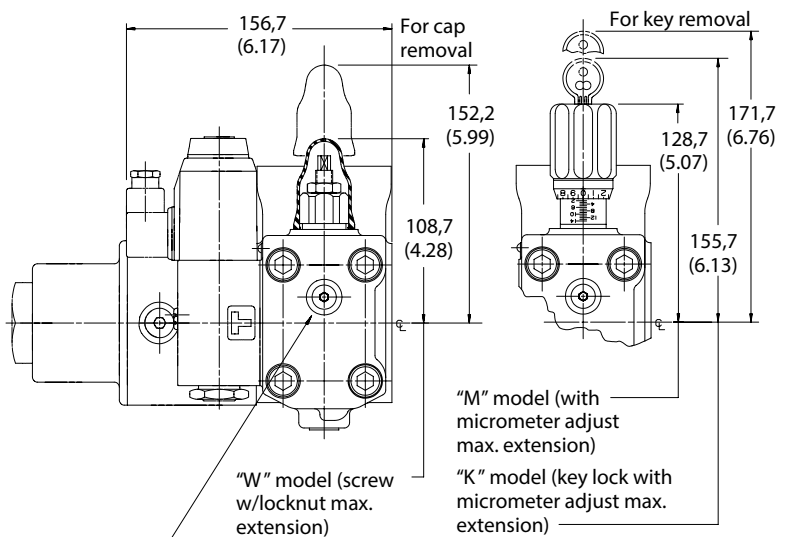

"W" model (screw w/locknut max. extension)  
 External drain port  
 - .5625-18 UNF-2B thd. for 3/8" O.D. tubing  
 - G 1/4 BSP thd.

"M" model (with micrometer adjust max. extension)  
 "K" model (key lock with micrometer adjust max. extension)

# DCPFS-08/10/12-\*\*-\*\*-20

## Right Angle Check Valves

### Flange Sizes

- 08 - 1 inch flange
- 10 - 1 1/4 inch flange
- 12 - 1 1/2 inch flange (Not available with Code 62 flanges.)

### Benefits

- Fast opening and closing and stable performance.
- Rugged, shock resistant, offset poppet design ensures long service life.
- Easier installation and servicing of components.
- Superior leak resistance due to SAE flange mounting and reduced piping.

Ratings	DCPFS-08	DCPFS-10	DCPFS-12
Maximum flow	114 l/min (30 USgpm)	227 l/min (60 USgpm)	378 l/min (100 USgpm)
Maximum pressure	275 bar (4000 psi)	275 bar (4000 psi)	275 bar (4000 psi)

### General Description

This Vickers by Danfoss DCPFS check valve is flange mounted to increase design flexibility and reduce external piping. Fewer leak points and SAE flange connections lead to installations with superior leak resistance.

The DCPFS check valve is designed for direct mounting on a pump flange, or may be stacked with the CPF series relief valves to provide a pump unloading function. The DCPFS is not intended to be used with the UPFS unloading valve.

Poppet design lifts easily to permit flow and reseats quickly to form a leakproof check to block flow in the opposite direction. The DCPFS check valves can be mounted in any position.

The DCPFS check valve has excellent operating characteristics with sizes that make it possible to choose the optimum model for each application.

### Right Angle Check Model Code

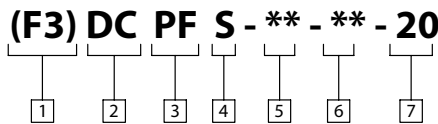

<p>1 Special Seals</p> <p>F3 - For mineral oil &amp; fire resistant fluids. (Omit if not required)</p>	<p>4 Flange Type</p> <p>S - SAE J518 4-bolt flange standard, series code 61</p>	<p>6 Spring Cracking Pressure</p> <p>5 - 0,3 bar (5 psi) 50 - 3,4 bar (50 psi) 75 - 5,2 bar (75 psi)</p>
<p>2 Valve Function</p> <p>DC - Check valve</p>	<p>5 Valve Size</p> <p>08 - 1" flange 10 - 1 1/4" flange 12 - 1 1/2" flange</p>	<p>7 Design Number, 20 Series</p> <p>Subject to change. Installation dimensions unaltered for design numbers 20 to 29 inclusive.</p>
<p>3 Mounting Type</p> <p>PF - Pump flange mounting</p>		

# DICPFS-06/08/10/12-\*\*-\*\*-10

## In-Line Check Valves

### Flange Sizes

- 06 - 3/4 inch flange
- 08 - 1 inch flange
- 10 - 1 1/4 inch flange
- 12 - 1 1/2 inch flange (Available with Code 62 high pressure.)

Ratings	DICPFS-06	DICPFS-08	DICPFS-10	DICPFS-12*
Maximum flow	120 l/min (32 USgpm)	300 l/min (80 USgpm)	600 l/min (160 USgpm)	750 l/min (200 USgpm)
Maximum pressure	350 bar (5000 psi)	350 bar (5000 psi)	280 bar (4000 psi)	207 bar (3000 psi)

\* DICPFV-12 Code 62 high pressure flange is rated at 750 l/min (200 USgpm) at 350 bar (5000 psi)

### Features

- Direct mounting to SAE flange.
- Compact, robust design.
- Low pressure drop design.
- Wide flow/pressure range.

### General Description

Vickers by Danfoss flange mounted in-line check valves can be used with the existing line of flange mounted pressure controls. The DICPF in-line check valves come in four sizes, 06 (.75 "), 08 (1 "), 10 (1.25 ") and 12 (1.50 ").

These are direct, flange mounted, in-line check valves with SAE 4-bolt mounting. They may be mounted directly on an SAE pump flange, actuator, manifold or may be stacked with a Vickers by Danfoss CPF relief valve to provide a pump unloading function.

This mounting style results in a much smaller space requirement and eliminates plumbing and potential leak points that result from installation of conventional line mounted check valves.

These check valves are not to be used with the UPF flange mounted unloading relief valves.

### In-Line Check Model Code

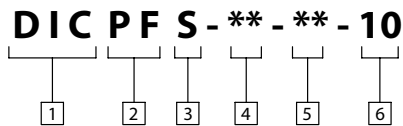

<b>1</b> Valve Function DIC – Direct inline check	<b>3</b> Flange Type S – SAE J518 4-bolt flange, std. pressure series, code 61 V – SAE J518 4-bolt flange, high pressure series, code 62 (1.50 in. models only)	<b>5</b> Cracking Pressure 05 – 0,3 bar (5 psi) 25 – 1,7 bar (25 psi)
<b>2</b> Mounting Type PF – Pump flange mounting	<b>4</b> Valve Size 06 – 0.75 in. flange, SAE-12 08 – 1.00 in. flange, SAE-16 10 – 1.25 in. flange, SAE-20 12 – 1.50 in. flange, SAE-24	<b>6</b> Design Number

# Pressure Drop Data

## Right Angle Check Valves

### DCPFS-08

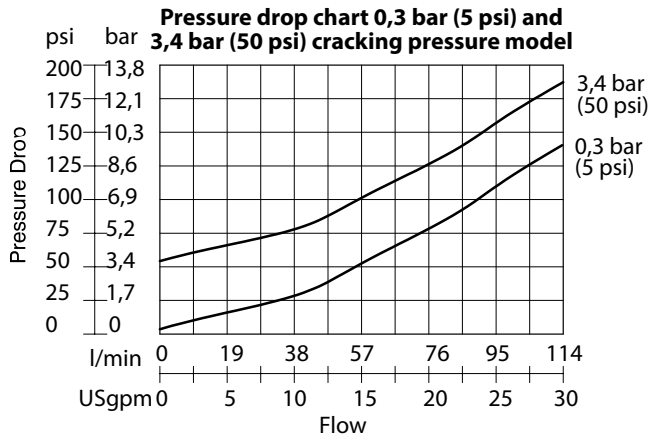

### DCPFS-10/12

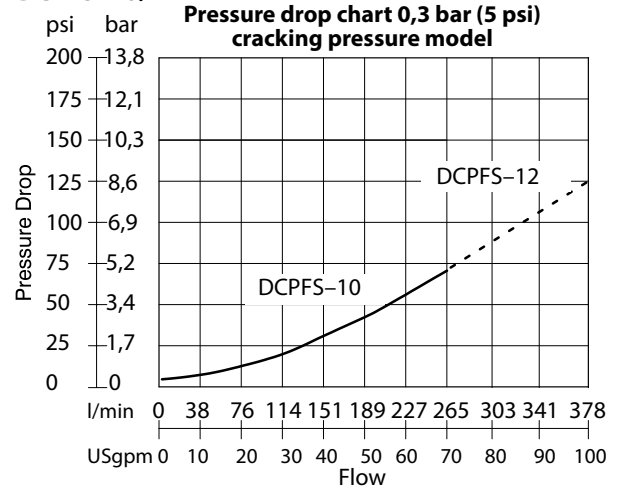

## In-Line Check Valves

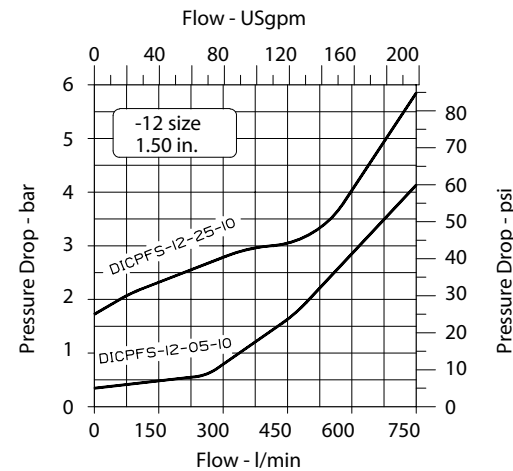
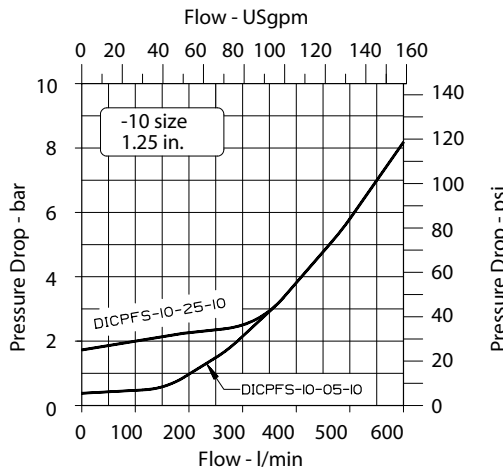
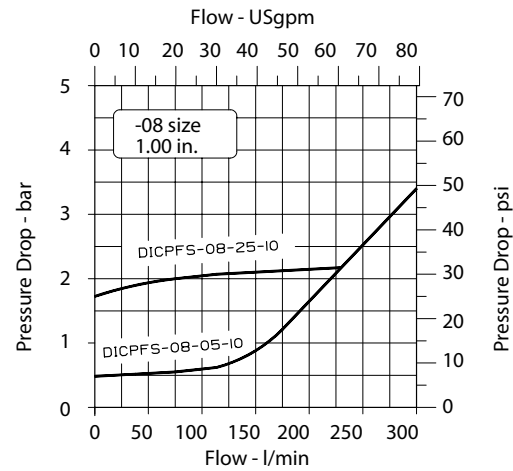
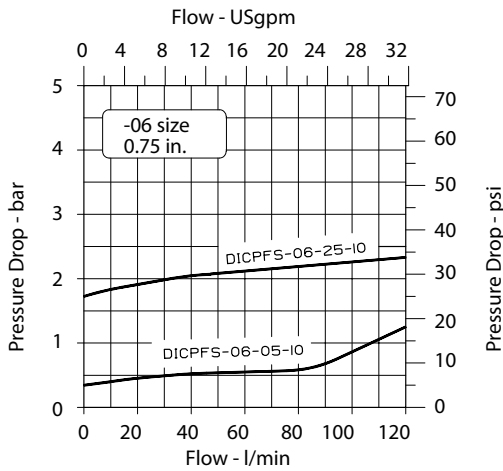

# Installation Dimensions

## DCPFS - 08/10/12 Right Angle Check Valve

mm (inch)

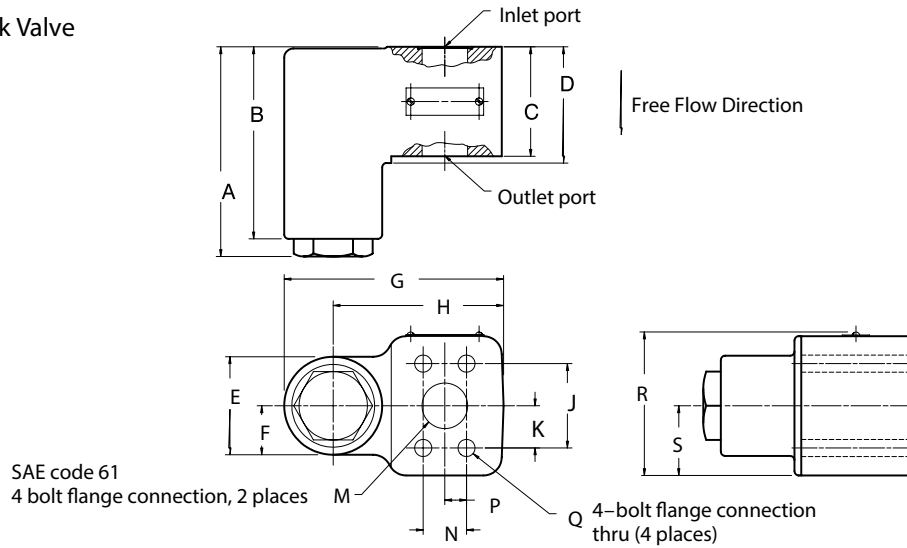

### Dimensions

Model	A	B	C	D	E	F	G	H	J	K	SAE flange M	N	P	4-bolt flange Q	R	S
DCPFS -08	102,9 (4.05)	91,9 (3.62)	59,9 (2.36)	64,8 (2.55)	57,2 (2.25)	28,4 (1.12)	135,1 (5.32)	106,7 (4.20)	52,3 (2.06)	26,2 (1.03)	25,4 (1.00) Dia.	26,2 (1.03)	13,2 (.52)	10,3 (.406) Dia.	85,3 (3.36)	41,1 (1.62)
DCPFS -10	146,0 (5.75)	133,6 (5.26)	76,2 (3.00)	80,8 (3.18)	68,3 (2.69)	34,0 (1.34)	152,9 (6.02)	118,6 (4.67)	58,7 (2.31)	29,5 (1.16)	31,7 (1.25) Dia.	30,2 (1.19)	15,0 (.59)	11,9 (.469) Dia.	99,8 (3.93)	48,5 (1.91)
DCPFS -12	146,0 (5.75)	133,6 (5.26)	76,2 (3.00)	80,8 (3.18)	68,3 (2.69)	34,0 (1.34)	152,9 (6.02)	118,6 (4.67)	69,8 (2.75)	35,1 (1.38)	38,1 (1.50) Dia.	35,8 (1.41)	17,8 (.70)	13,5 (.531) Dia.	99,8 (3.93)	48,5 (1.91)

## DICPF\* -06/ 08/10/12 In-Line Check Valve

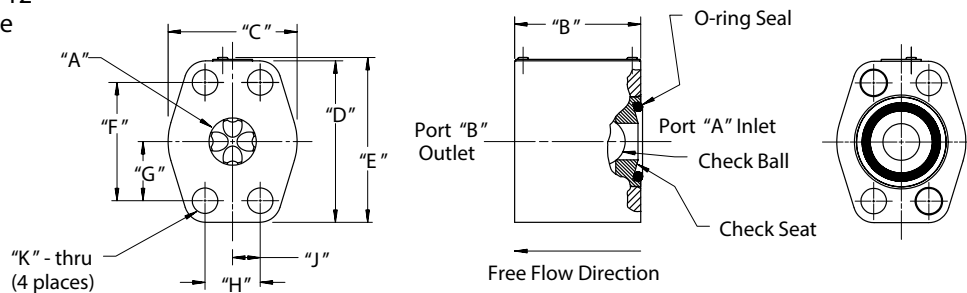

### Standard Pressure Series (Code 61) mm (inch)

Flange Size (inch)	Model Code	"A"	"B"	"C"	"D"	"E"	"F"	"G"	"H"	"J"	"K"
3/4"	S - 06	19,1 (.75)	50,8 (2.0)	52,0 (2.05 )	65,0 (2.56)	66,5 (2.61)	47,6 (1.88)	23,8 (.906)	22,2 (.875)	11,1 (.437)	10,4 (.407)
1"	S - 08	25,4 (1.00)	60,0 (2.36)	58,5 (2.30)	70,0 (2.76)	71,5 (2.81)	52,4 (2.06)	26,2 (1.03)	26,2 (1.03)	13,1 (.516)	10,4 (.407)
1 1/4"	S - 10	31,6 (1.25)	70,0 (2.76)	73,0 (2.88)	79,0 (3.11)	80,5 (3.16)	58,7 (2.31)	29,4 (1.16)	30,2 (1.19)	15,1 (.594)	12,0 (.470)
1 1/2"	S - 12	38,1 (1.50)	76,2 (3.00)	82,5 (3.25)	93,5 (3.68)	95,0 (3.74)	69,9 (2.75)	34,9 (1.38)	35,7 (1.41)	17,9 (.703)	13,5 (.532)

### High Pressure Series (Code 62) mm (inch)

Flange Size (inch)	Model Code	"A"	"B"	"C"	"D"	"E"	"F"	"G"	"H"	"J"	"K"
1 1/2"	V - 12	38,1 (1.50)	76,2 (3.00)	95,0 (3.74)	112,5 (4.43)	114,0 (4.48)	79,4 (3.13)	39,7 (1.56)	35,7 (1.44)	18,3 (.720)	16,7 (.657)

# Application Data

## Service Information

Refer to the following service drawings for parts breakdown:

CPF1S-06/08/10/12	I-3777-S
CPF2S-06/08/10/12	I-3778-S
CPF3/4S-06/08/10/12	I-3779-S
UPF1S-06/08/10/12	I-3768-S
UPF2S-06/08/10/12	I-3769-S
DCPFS-06/08/10/12	I-3435-S
Pilot valve service drawing:	
DG4V-3(S)-**-60	I-3886-S

## Weights

CPF1S – 06	5,4 kg (12 lbs)	UPF1S-10 w/check	14,5 kg (32 lbs)
CPF2S – 06	6,9 kg (15.5 lbs)	UPF1S-10 w/o check	8,2 kg (18 lbs)
CPF3/4S – 06	9,2 kg (20.5 lbs)	UPF2S-10 w/check	15,9 kg (35 lbs)
CPF1S – 08	5,5 kg (12.3 lbs)	UPF2S-10 w/o check	9,5 kg (21 lbs)
CPF2S – 08	7,1 kg (15.8 lbs)	UPF1*-12 w/check	16 kg (35.3 lbs)
CPF3/4S – 08	9,4 kg (20.8 lbs)	UPF1*-12 w/o check	9,6 kg (21.3 lbs)
CPF1S – 10	8,2 kg (18 lbs)	UPF2*-12 w/check	17,3 kg (38,3 lbs)
CPF2S – 10	9,5 kg (21 lbs)	UPF2*-12 w/o check	11 kg (24,3 lbs)
CPF3/4S – 10	12 kg (26.5 lbs)	DCPFS – 08	3,6 kg (8 lbs)
CPF1* – 12	9,6 kg (21.3 lbs)	DCPFS – 10	5,9 kg (13 lbs)
CPF2* – 12	11 kg (24.3 lbs)	DCPFS – 12	5,9 kg (13 lbs)
CPF3/4* – 12	13,5 kg (29.8 lbs)	DICPFS – 06	0,8 kg (1.59 lbs)
UPF1S-06 w/check	8,9 kg (19.8 lbs)	DICPFS – 8	1,2 kg (2.43 lbs)
UPF1S-06 w/o check	5,3 kg (11.8 lbs)	DICPFS – 10	1,9 kg (4.23 lbs)
UPF2S-06 w/check	10,6 kg (23.5 lbs)	DICPFS – 12	2,6 kg (5.58 lbs)
UPF2S-06 w/o check	7 kg (15.5 lbs)		
UPF1S-08 w/check	8,9 kg (19.8 lbs)		
UPF1S-08 w/o check	5,3 kg (11.8 lbs)		
UPF2S-08 w/check	10,6 kg (23.5 lbs)		
UPF2S-08 w/o check	7 kg (15.5 lbs)		

## Ordering Procedure

When ordering a unit please specify the complete model code, as detailed in the model code sections, which is applicable to your requirements.

## 4-Bolt SAE Code 61 Flanges\* (Maximum operating pressure 207 bar (3000psi))

mm (inches)

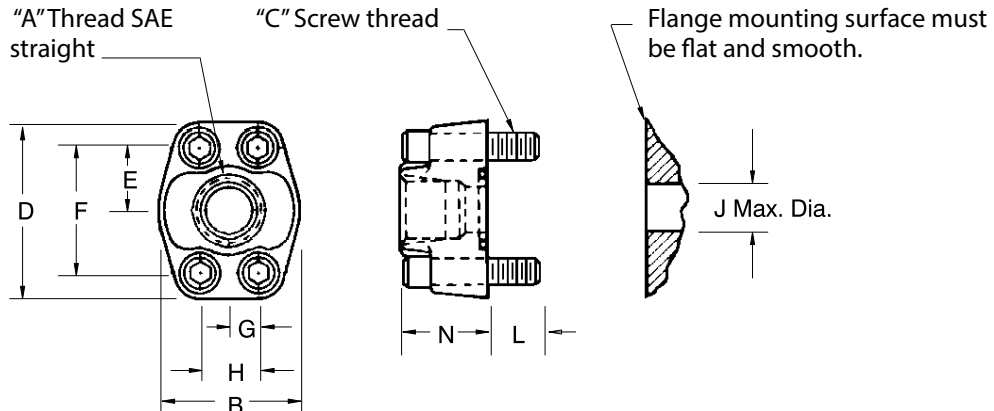

\* For additional information on SAE 4-bolt flanges see Vickers by Danfoss Catalog 700 or GB-C-2005A

Model	Assembly	A SAE Straight Thread	B	C	D	E	F	G	H	J	L	N
FL1-6-12S-10	683829	1.0625-12 (3/4" tube)	52,3 (2.06)	3/8-16	65,0 (2.56)	23,6 (.93)	47,8 (1.88)	10,9 (0.43)	22,2 (.875)	19,1 (.750)	13,5 (0.53)	31,8 (1.25)
FL1-8-16S-10	683830	1.3125-12 (1.0" tube)	58,7 (2.31)	3/8-16	70 (2.75)	26,2 (1.03)	52.4 (2.06)	13,2 (0.52)	26,2 (1.03)	25,4 (1.00)	16,8 (0.66)	35,1 (1.38)
FL1-10-20S-10	683832	1.625-12 (1 1/4" tube)	73,2 (2.88)	7/16-14	79,2 (3.12)	29,5 (1.16)	58,7 (2.31)	15 (0.59)	30,2 (1.19)	31,8 (1.25)	21,3 (0.84)	38,1 (1.50)
FL1-12-24S-10	683832	1.875-12 (1 1/2" tube)	82,6 (3.25)	1/2-13	93,7 (3.69)	35,1 (1.38)	69,9 (2.75)	17,8 (0.70)	35,8 (1.41)	38,1 (1.50)	18,5 (0.73)	41,1 (1.62)

# Fluid Cleanliness

## Hydraulic Fluid Information

Essential information on the correct methods for treating hydraulic fluid is included in Vickers by Danfoss publication 561; "Vickers Guide to Systemic Contamination Control," available from your local Vickers by Danfoss distributor or by contacting Danfoss Power Solutions.

Recommendations on filtration and the selection of products to control fluid condition are included in Vickers by Danfoss publication 561.

Recommended cleanliness levels using petroleum oil under common conditions is based on the highest fluid pressure levels in the system:

In referencing the table below, the shaded area highlights the recommended cleanliness level for flange mounted valves.

Fluids other than petroleum, severe service cycles or temperature extremes are cause for adjustment of these cleanliness codes. See Vickers by Danfoss publication 561 for exact details.

SYSTEM PRESSURE LEVEL			
PRODUCT	69 bar (1000 psi)	138 bar (2000 psi)	207+ bar (3000+ psi)
Vane Pumps – Fixed	20/18/15	19/17/14	18/16/13
Vane Pumps – Variable	18/16/14	17/15/13	
Piston Pumps – Fixed	19/17/15	18/16/14	17/15/13
Piston Pumps – Variable	18/16/14	17/15/13	16/14/12
Directional Valves	20/18/15	20/18/15	19/17/14
Pressure/Flow Control Valves	19/17/14	19/17/14	19/17/14
Servo Valves	16/14/11	16/14/11	16/13/10
Proportional Valves	16/14/12	16/14/12	15/13/11
Cylinders	20/18/15	20/18/15	20/18/15
Vane Motors	20/18/15	19/17/14	18/16/13
Axial Piston Motors	19/17/14	18/16/13	17/15/12
Radial Piston Motors	20/18/14	19/17/13	18/16/13



### Products we offer:

- Cartridge valves
- DCV directional control valves
- Electric converters
- Electric machines
- Electric motors
- Gear motors
- Gear pumps
- Hydraulic integrated circuits (HICs)
- Hydrostatic motors
- Hydrostatic pumps
- Orbital motors
- PLUS+1® controllers
- PLUS+1® displays
- PLUS+1® joysticks and pedals
- PLUS+1® operator interfaces
- PLUS+1® sensors
- PLUS+1® software
- PLUS+1® software services, support and training
- Position controls and sensors
- PVG proportional valves
- Steering components and systems
- Telematics

**Danfoss Power Solutions** is a global manufacturer and supplier of high-quality hydraulic and electric components. We specialize in providing state-of-the-art technology and solutions that excel in the harsh operating conditions of the mobile off-highway market as well as the marine sector. Building on our extensive applications expertise, we work closely with you to ensure exceptional performance for a broad range of applications. We help you and other customers around the world speed up system development, reduce costs and bring vehicles and vessels to market faster.

Danfoss Power Solutions – your strongest partner in mobile hydraulics and mobile electrification.

### Go to [www.danfoss.com](http://www.danfoss.com) for further product information.

We offer you expert worldwide support for ensuring the best possible solutions for outstanding performance. And with an extensive network of Global Service Partners, we also provide you with comprehensive global service for all of our components.

Local address:

### Hydro-Gear

[www.hydro-gear.com](http://www.hydro-gear.com)

### Daikin-Sauer-Danfoss

[www.daikin-sauer-danfoss.com](http://www.daikin-sauer-danfoss.com)

**Danfoss  
Power Solutions (US) Company**  
2800 East 13th Street  
Ames, IA 50010, USA  
Phone: +1 515 239 6000

**Danfoss  
Power Solutions GmbH & Co. OHG**  
Krokamp 35  
D-24539 Neumünster, Germany  
Phone: +49 4321 871 0

**Danfoss  
Power Solutions ApS**  
Nordborgvej 81  
DK-6430 Nordborg, Denmark  
Phone: +45 7488 2222

**Danfoss  
Power Solutions Trading  
(Shanghai) Co., Ltd.**  
Building #22, No. 1000 Jin Hai Rd  
Jin Qiao, Pudong New District  
Shanghai, China 201206  
Phone: +86 21 2080 6201

Danfoss can accept no responsibility for possible errors in catalogues, brochures and other printed material. Danfoss reserves the right to alter its products without notice. This also applies to products already on order provided that such alterations can be made without subsequent changes being necessary in specifications already agreed. All trademarks in this material are property of the respective companies. Danfoss and the Danfoss logotype are trademarks of Danfoss A/S. All rights reserved.