

Introduction

Over the past twenty years, the application of hydraulics in agricultural, construction and materials handling vehicles has seen a meteoric rise. In fact, virtually all modern vehicles use fluid power, and new vehicles and markets are appearing as fast as the development of new products and concepts will allow.

Vehicle size and work capacity are growing. Today's front-end loaders, for example, have bucket capacities equal to the capacities of scrapers of just a few years ago. To provide equipment with still larger load capacities, and increased speed to do the job faster, the trend is toward high-speed, high-pressure hydraulic pumps and motors that allow system components to remain relatively small.

To meet the ever increasing demands for fast positive action, longer service life and economical vehicle operation, Danfoss offers you the large selection of top-quality, precision-built pumps and motors described in the following pages. They are backed by over seven decades of experience with every type of hydraulic equipment.

You can always depend on Danfoss for the finest, most advanced hydraulic products and the best in customer service. Danfoss has the worldwide facilities and skilled personnel to give you prompt deliveries, volume production, and application and service assistance when you need it.

Table of Contents

Applying Vane Units

Pump & Motor Characteristics and Drives	7
Mounting Dimensions, Circuitry Requirements, Fluid and Fluid Cleanliness	8
Reservoirs	9
Pump Startup Procedure	10

Pumps, Single - 20VQ through 45VQ Series

Description	11
Operating Specifications	13
Model Codes	14
Installation Dimensions	16
Optional Shafts	19
Performance Curves	21
Shaft Torque Data	59

Pumps, Double - 2520VQ through 4535VQ

Description	11
Operating Specifications	25
Model Codes	26
Installation Dimensions	28
Optional Shafts	32
Performance Curves	34
Shaft Torque Data	59

Pumps, Triple – 2520VQSV10 through 4535VQSV10 Series

Description	11
Operating Specifications	45
Performance Curves Reference Table	45
Model Codes	46
Installation Dimensions	47
Shafts	48
Shaft Torque Data	59

Pumps, Single Thru-Drive – 25VQT*S through 45VQT*S

Description	11
Operating Specifications	49
Performance Curves Reference Table	49
Model Codes	50
Installation Dimensions	51
Thru-drive Rear Mountings	54
Optional Shafts	58
Shaft Torque Data	59

Pumps, Double Thru-Drive – 3525VQT*S and 4525VQT*S

Description	11
Operating Specifications	60
Model Codes	61
Installation Dimensions	62
Thru-drive Rear Mountings	64
Shaft Torque Data	66

Pumps, Single – V10 & V20 Series	
Description	68
Operating Specifications	69
Model Codes	70
Installation Dimensions	71
Optional Shafts	74
Performance Curves	75
Pumps, Double – V2010 & V2020 Series	
Description	68
Operating Specifications	80
Model Codes	81
Installation Dimensions	82
Optional Shafts	85
Performance Curves	86
Pumps, Power Steering – VTM42 Series	
Description	91
Operating Specifications and Model Codes	92
Installation Dimensions	93
Performance Curves	96
Motors – M2U & M2-200 Series	
Description	98
Operating Specifications and Model Codes	99
Installation Dimensions	100
Optional Shafts	101
Performance Curves	102
Motors – 25M through 50M Series	
Description	105
Operating Specifications and Model Codes	106
Installation Dimensions	107
Optional Shafts	109
Performance Curves	110
Accessory Products	
Foot Mounts	119
Filler/Breather Unit	120
SAE 4-Bolt Solid Flanges	121
Oil Recommendations	122
Hydraulic Formulae	123
Flow Capacities of Piping	124

Applying Vane Units

Pump Characteristics

Maximum Speed

Maximum rated pump speeds are based on one atmosphere of inlet pressure (14.7 psia) with the pump at sea level and operating with SAE 10W oil at 38° to 82° C (100° to 180° F), unless otherwise specified.

Minimum Speed

Minimum recommended starting speed, under fluid conditions stated above, is generally 600 r/min. However, the pump size, system characteristics and environmental conditions can raise or lower this speed. A lower speed can often be achieved after the pump has primed.

If low starting or operating speeds are required, consult your Danfoss representative.

Inlet Pressure

Recommended inlet pressure is 0 to 0,34 bar (0 to 5 psi) gauge. Inlet pressure should not exceed 1,38 bar (20 psi). Inlet depressions should not exceed 0,17 bar (5" of Hg or 12.2 psia).

Rated Pressure

Pumps should not be operated at or near rated pressures at idle speeds for extended periods. Localized overheating and damage can result.

Never assume pumps in a double, triple or thru-drive pump assembly can be simultaneously loaded to rated pressure. Shaft loading must be checked for excessive torque and side loads.

Pump Supercharge Pressure

A pressurized reservoir system does not always assure a positive (supercharge) pressure at the pump inlet. Vacuum at the pump inlet can result during cold start-ups. Avoid high speeds until the circuit has warmed and supercharge pressure actually exists at the pump inlet. When vacuum breaker pressure caps are used on the reservoir, exercise implements to obtain reservoir precharge.

Motor Characteristics

Minimum Speed

Normal operating motor speeds can be as low as 50 to 100 r/min. Lower operating speeds are permissible depending on torque requirements of the motor and characteristics of the driven load.

Stall Torque

Motor stall torque ranges between 65% and 100% of 1200 r/min running torque for a given pressure differential across the motor. This is dependent on the specific angular position of the shaft at stall and the volume supply of fluid to the motor.

Hydraulic Braking

Motors may be used as retarders but may not be used as hydraulic brakes. Systems requiring positive holding capabilities must be provided with externally operated mechanical holding devices.

The maximum pressure obtainable in a system using a motor as a retarder (pumping) is dependent upon speed. At speeds below 1000 r/min, maximum obtainable pressure is proportionally diminished relative to speed as speed approaches stall.

When a motor is used as a retarder, adequate pressure must be provided at the inlet port to prevent cavitation. Consult your Danfoss representative before using motors as retarders.

Drives

Recommended Drives

Danfoss units are designed for use on direct coaxial drives using spline connections and/or flexible couplings. If drives imposing radial or axial loads, or key drives, are being considered, consult your Danfoss representative for additional information.

Drive Alignment

Concentricity and angular alignment of shafts are important to pump life. Misalignment can induce heavy loads on bearings, causing premature failure. Flexible coupling halves must be aligned according to the coupling manufacturer's recommendations.

Universal Joints

When using double universal joint couplings, the shafts must be parallel and the yokes must be in line. The offset should be kept as low as possible. Maximum allowable offset will, of course, vary with application conditions. The pump shaft to universal joint diametral fit should be close (major diameter fit) with no looseness.

Mounting Pad Accessory Drives

A splined shaft is recommended on applications where the pump shaft is coupled directly into a transmission or gearbox. Spline drives should be lubricated.

The possibility of interference between the shaft and transmission splines, due to tolerance stack-up, can exist. To reduce this possibility, side tooth spline fits should be used. A side tooth fit and short length of engagement permits more flexibility and less tendency for side loading than does a major diameter fit spline or long spline engagement.

Mounting Dimensions

Requirements

Dimensional control requirements of the customer's mounting pad to which the pump or motor is affixed are as follows.

Pilot Diameter

Concentricity of the customer's female pilot diameter relative to the effective axis of the female drive must be within 0,10 mm (.004 in.) total indicator reading. The clearance between the male and female pilot diameters must be +0,01 to +0,05 mm (+.0005 to +.0020 in.).

Mounting Face

The customer's mounting face to which the pump or motor is affixed must be square to the axis of the female drive within 0,0381 mm per mm (.0015 inch per inch).

Shafts

Dimensions of keyed shaft receivers must be between +0,003 and +0,03 mm (+.0001 and +.0010 in.) of the maximum shaft diameter shown on the Danfoss installation drawing.

Circuitry Requirements

Valves

In the event of acceleration or deceleration of the drive or driven members, overrunning loads or system bleed-off, control valves and circuitry must provide a continuous supply of oil to the pump or motor. This supply should be sufficient to prevent transient or continuous cavitation, but not so large as to result in speeds beyond the published maximum speed.

Protect against hydraulic surge pressures (inlet, outlet or drain) applied to or generated by the pump or motor. Relief valves must prevent these surges from exceeding published pressure ratings.

Never assume a relief valve setting is the maximum pressure a pump experiences. Shock conditions may exist which can exceed circuit and pump limitations.

Piping

Hydraulic lines should be as short and have as large an inside diameter as possible. Where lines are long, it is desirable to adapt to a larger capacity line than a unit's ports specify. Inlet, outlet and drain lines should not be smaller than the nominal port size shown on installation drawings. A "Y" shaped inlet should not be used to feed two separate pumps because one may be starved and cavitate.

There should be as few bends and fittings in lines as possible. High-pressure lines and fittings are restrictive to flow and may result in excessive pressure drop through the system. They should be used only where necessary in a pressure line.

Hose

Because steering components move during operation, their working hydraulic lines consist mainly of flexible hoses. Long lines may be partly flexible hose and partly tubing where flexibility is not required.

When installing a hose, allow enough slack to avoid kinking. A taut hose will not allow movement with pressure surges. Slack in the line compensates for surges, relieving strain. The hose should not be twisted during installation or while in operation. Twisting will weaken the hose and loosen connections.

For power steering pumps using a remote reservoir, connecting hoses should not exceed three feet in length. It is highly desirable to design the reservoir-pump relationship so that there is always a static head on the pump inlet port.

A neater installation is usually obtainable by using extra fittings to minimize unusually long loops in a line. Hoses should be clamped to prevent rubbing and entanglement with moving parts. Where hoses are subject to chafing, they should be run through protective neoprene hose or shielded metallic guards.

Fluid Considerations

Preferred Viscosity

Normal pump operation (at rated conditions) is based on the use of SAE 10W oil in the 38° to 82° C (100° to 180° F) range (or comparable viscosities).

Permissible Viscosity

When operating with SAE 10W oil in the 860 to 40 cSt (4000 to 180 SUS) range (-12° to 35° C or 10° to 95° F oil temp.), the speed and pressure of the pump should be limited to 50% or less of their respective rated value until the system has warmed up. Caution must be used in starting units when fluid viscosity is greater than 860 cSt (4000 SUS). Care should be exercised to warm up the entire system (fluid). Remote components (cylinders, motors) should be actuated during the warm-up process.

Fluid viscosities must not be less than 60 SUS, and temperatures should not exceed 99° C (210° F), because the life expectancy of rotating groups and elastomers will decrease.

Care should be taken to change to appropriate oil viscosities when climatic conditions change. See recommendations for mobile hydraulic systems on pages 122 and 123. Consult your Danfoss representative for applicable decreases in ratings, and modifications, if fluids other than SAE type oils are considered.

Fluid Cleanliness

Proper fluid condition is essential for long and satisfactory life of hydraulic components and systems. Hydraulic fluid must have the correct balance of cleanliness, materials, and additives for protection against wear of components, elevated viscosity and inclusion of air.

Essential information on the correct methods for treating hydraulic fluid is included in Danfoss publication 561; "Vickers Guide to Systemic Contamination Control," available from your local Danfoss distributor or by contacting Danfoss, Incorporated. Recommendations on filtration and the selection of products to control fluid condition are included in this publication.

Recommended cleanliness levels using petroleum oil under common conditions are based on the highest fluid pressure levels in the system. See Figure 1.

Fluids other than petroleum, severe service cycles or temperature extremes are cause for adjustment of these cleanliness codes. See Danfoss publication 561 for exact details.

Applying Vane Units

Product	System Pressure Level		
	1000 psi	2000 psi	3000+ psi
Vane Pumps - fixed	20/18/15	19/17/14	18/16/13
Vane Pumps - variable	8/16/14	17/15/13	
Piston Pumps - fixed	19/17/15	18/16/14	17/15/13
Piston Pumps - variable	18/16/14	17/15/13	16/14/12
Directional Valves	20/18/15	20/18/15	19/17/14
Proportional Valves	17/15/12	17/15/12	15/13/11
Pressure/Flow Controls	19/17/14	19/17/14	19/17/14
Cylinders	20/18/15	20/18/15	20/18/15
Vane Motors	20/18/15	19/17/14	18/16/13
Axial Piston Motors	19/17/14	18/16/13	17/15/12
Radial Piston Motors	20/18/14	19/17/13	18/16/13

Figure 1

Aeration

Reservoir and circuit design must prevent aeration of the fluid. Particular care must be used to employ joints, seals and gaskets that will not leak or deteriorate. This is especially important in low pressure and suction lines. Connections should always be tight to prevent air from entering the system.

It is best to use windows and sight glasses in the reservoir and inlet lines during prototype evaluation to determine whether significant amounts of air are present in the fluid. Any opaqueness or milky appearance of the fluid in the lines or reservoir indicates excessive aeration. Bubbles on the surface of the reservoir fluid may indicate that excessive aeration is present.

Reservoirs

Oil Level

The oil level of the reservoir should be as high as possible above the pump suction line opening. All return lines should discharge near the tank bottom, always below the oil level, and as far from the pump inlet as possible.

For power steering pumps using a remote reservoir, the oil level should not be lower than one foot below the pump shaft centerline.

Reservoirs should incorporate a sight gauge, dipstick or other means for easy checking of the oil level. Without these devices, the oil level often goes unchecked and, should a leak occur, the pump can be starved and damaged from loss of lubrication.

Location

Preferably, reservoirs should be located above pumps. This creates a flooded pump inlet which reduces the possibility of pump cavitation.

Line Connections

Pump suction and tank return lines should be attached to the reservoir by flanges or welded heavy-duty coupling. If the suction line is connected to the bottom of the reservoir, the coupling should extend above the bottom inside the tank. This prevents residual dirt from getting into the suction line when

the tank is cleaned. The seals used on all suction line connections should be such that they will not deteriorate and leak.

Baffle Plate

A baffle plate in the reservoir is desirable to separate the suction and return lines. The plate causes return oil to circulate around the outer wall of the reservoir for cooling before it re-enters the pump. It also helps provide time for entrained air to separate from the oil. Baffle plate openings should be designed so that cascade effects and resultant air entrainment are minimized.

Magnets

Magnets in a reservoir should be able to pick up ferrous particles not retained by filters or strainers. Magnets should be assembled to the support bars located between suction and return lines, and be accessible for cleaning.

Filler/Breather

Most reservoirs are vented to the atmosphere through an opening that lets air leave or enter the space above the oil as the oil level rises or falls. A filler/breather unit containing an air filtering element, such as shown on page 120, is often used as the vent. It must be large enough to handle the air flow required to maintain atmospheric pressure whether the tank is full or empty.

Pump Start-up Procedure

Preparation Prior to Start-up

The reservoir and circuit should be clean and free of dirt and debris prior to filling with fluid.

Circuit Cleanup

The reservoir should be charged with filtered hydraulic fluid. The fluid level should be sufficient to prevent vortexing at the suction connection to the pump inlet. It is good practice to clean the system by flushing and filtering, using an external slave pump.

Filling Pump and Removing Air

If the pump is mounted above the fluid level, it should be filled with fluid through the outlet port.

If the pump is mounted below the fluid level, the pump outlet fitting (or other downstream fitting or plug) can be loosened to allow fluid to displace the air. It may be necessary to loosen the fill cap on the reservoir to allow the fluid to flow freely. When a solid stream of fluid with no observed air begins to drain through the loosened fitting, the fitting should be retightened.

An air bleed valve in the outlet circuit is also recommended to remove trapped air. If such a device is used, the pump should be filled with fluid before start-up.

In some cases, it may be possible to prime the pump by running the engine starter for five to ten seconds with the throttle and/or ignition switch in the "off" position. It will be necessary to loosen a fitting or plug in the pump outlet to allow air to escape.

Pump Start-up

All controls should be placed in the neutral position so the pump is unloaded when started.

Start the engine and run at low idle.

Once the pump is started, it should prime and pump within a few seconds. If it does not, make sure there are no restrictions between the reservoir and the inlet to the pump, and that there are no air leaks in the inlet line and connections. Also, make sure that trapped air can escape from the outlet.

Run at low engine idle for approximately five minutes. Then, while observing the reservoir fluid level, operate the implements. Extend all actuators to maximum safe limits to completely fill the system with fluid.

Do not run with the fluid level below the "low" limit.

Add fluid to the reservoir to bring the fluid to the proper fill level.

VQ Series High Speed, High Pressure Pumps

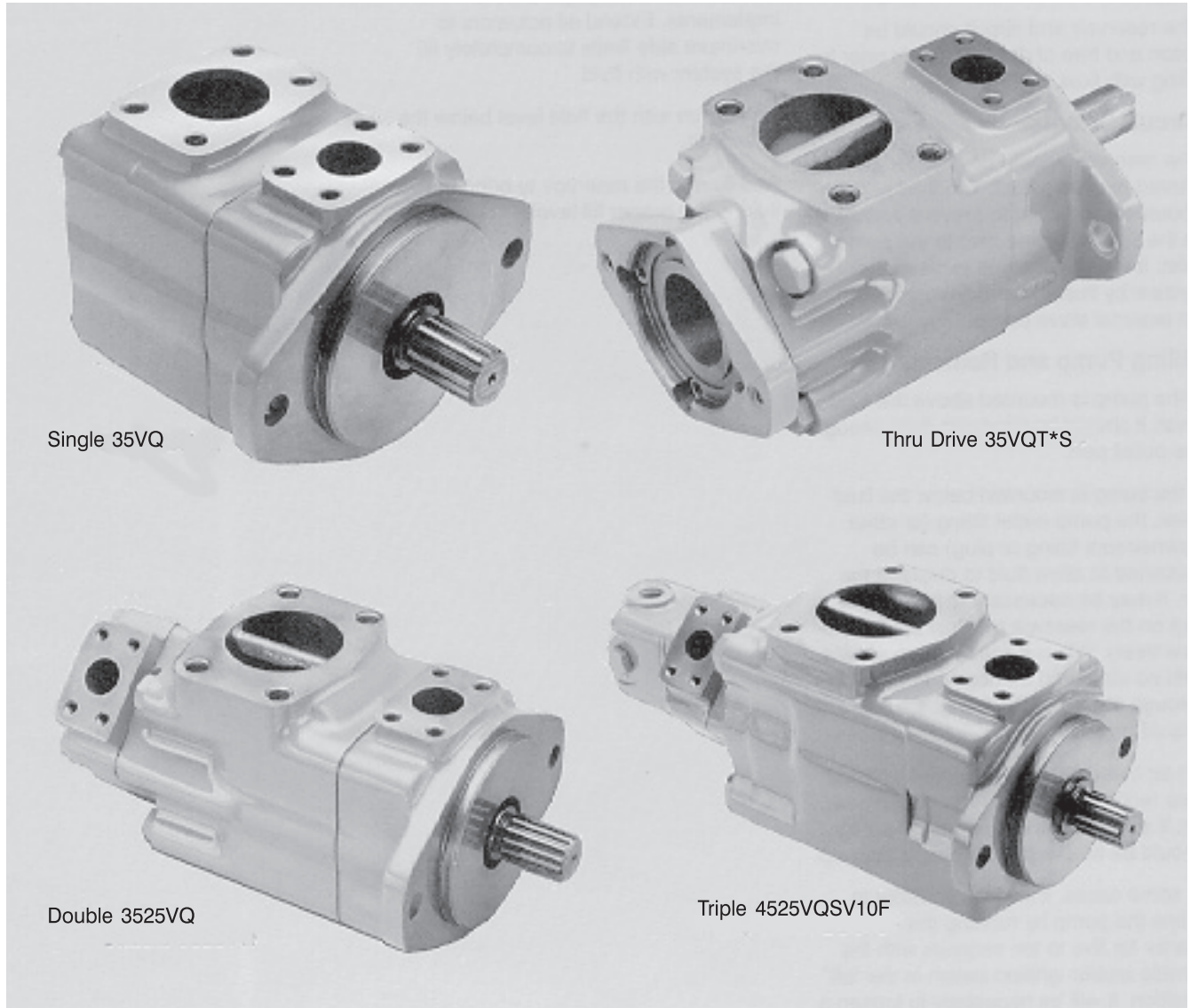

Single 35VQ

Thru Drive 35VQT*S

Double 3525VQ

Triple 4525VQSV10F

Design Features

In all pumps, except the rear pump of triple pumps, fluid flow is developed in a cartridge which consists principally of a cam ring, rotor, ten vanes, and unique side plates and support plates. The bimetallic flexible side plates are located on each side of the rotor with their bronze face toward the rotor and their steel face toward the support plate. Two cavities in each support plate hold high pressure oil against the flexible side plate, thereby hydrostatically balancing the flexible plate and providing optimum clearance with the rotor.

Performance

For a combination of maximum horsepower in a small package, high efficiency, serviceability and economy, Vickers "high output" pumps are unequalled anywhere in industry.

Durability

Danfoss high speed-high pressure pumps give more staying power – they last. Their workhorse ruggedness has been proved on the newest types of giant earth-moving equipment.

Reliability & Efficiency

Axial and radial running clearances, along with lubricating oil film on the rotor and vanes, are optimized over the entire operating pressure range. Excellent cold-start capability and superior resistance to seizure make Danfoss VQ pumps highly reliable and efficient.

Replaceable Cartridge

The pump cartridge described under design features is easy to service and can normally be replaced in ten minutes or less, without removing the pump from its mounting. A small stock of cartridges can serve many pump models on a variety of vehicles.

Hydraulic Balance

Pump inlet and outlet pressure chambers are diametrically opposed as shown in Figure 2. As a result, the rotor is hydraulically balanced. Bearings thus encounter no hydraulic loads, assuring long life.

Figure 3 shows an insert fitted into a slot in the vane. Outlet pressure is applied continuously only to the space between the vane and insert. Top and bottom areas of the vane are subject to either inlet or outlet pressure, depending upon the vane's location during rotor rotation. See Figure 2. Complete hydraulic balance is effected in the outlet pressure areas. Outward thrust by the vane in the inlet area is equal to the outlet pressure times the projected area of the end of the insert.

Double Pumps

Double pumps provide a single power source capable of serving two separate hydraulic circuits, or of providing greater volume through the combined delivery of both sections. In either type of application, two pumps in a single housing result in a more compact, simple installation and can be driven through a single shaft coupling.

Triple Pumps

Because triple pumps have three pumps in a single housing, they offer even more application versatility than do the double pumps described above.

Thru-Drive Pumps

These versions of single and double pumps have a rear pad for directly mounting and driving an additional pump. Many different multi-pump arrangements are thus possible.

Integral Valve Options

Single, double, and triple pumps are available with flow control and priority valve covers.

The flow control cover limits flow to the operating system to the desired maximum. Excess flow is diverted to tank. On double and triple pumps, the deliveries of the shaft-end and center pumps are proportional to speed.

The flow control cover also includes a relief valve to limit maximum operating pressure. Operating pressures of the shaft-end and center pumps of double and triple pumps must be controlled by separate, external relief valves.

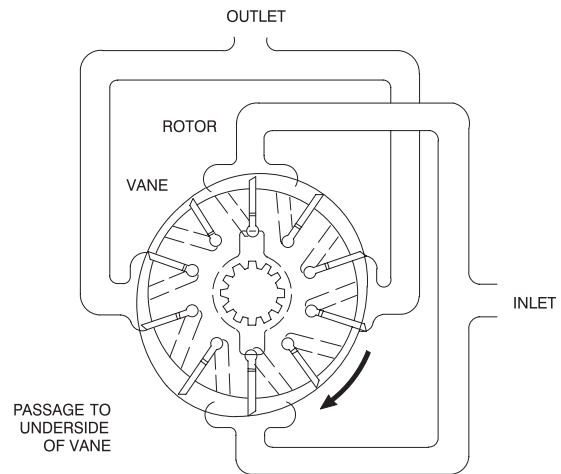

Figure 2

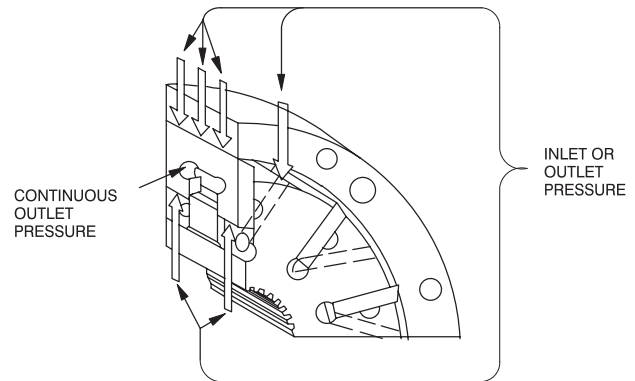

Figure 3

A typical application for the flow control is power steering, where it provides a constant supply of oil throughout the vehicle engine's mid to high speed range.

The priority valve cover maintains a nearly constant flow to a primary circuit and diverts remaining flow to a secondary circuit. The amount of flow going to the secondary circuit is determined by pump delivery. The primary circuit is protected by an integral relief valve, but an external relief valve must be provided for the secondary and any additional circuit.

Single Pump Operating Specifications

Model Series	Delivery @ 1200 r/min USgpm (7 bar (100 psi))	Displ. cm ³ /r (in ³ /r)	Max. r/min	Max. bar (psi)	Typical del. L/min (USgpm) @ max. speed & pressure	Typical input kW (hp) @ max. speed & pressure	Weight kg (lb)
20VQ	5	18,0 (1.10)	2700	210 (3000)	42,3 (11)	17,9 (24)	11,8 (26)
	8	27,4 (1.67)	2700	210 (3000)	65,4 (17)	26,1 (35)	
	11	36,4 (2.22)	2700	210 (3000)	88,5 (23)	35,4 (47.5)	
	12	39,5 (2.41)	2700	160 (2300)	98,1 (25.5)	28,4 (38)	
	14	45,9 (2.80)	2700	140 (2000)	115,4 (30)	29,1 (39)	
25VQ	12	40,2 (2.45)	2700	210 (3000)	88,5 (23)	41,0 (55)	14,5 (32)
	14	45,4 (2.77)	2700	210 (3000)	103,8 (27)	46,6 (62.5)	
	17	55,2 (3.37)	2500	210 (3000)	119,2 (31)	51,8 (69.5)	
	21	67,5 (4.12)	2500	210 (3000)	146,2 (38)	61,9 (83)	
35VQ	25	81,6 (4.98)	2500	210 (3000)	173,1 (45)	75,3 (101)	22,7 (50)
	30	97,7 (5.96)	2500	210 (3000)	211,5 (55)	87,7 (117.5)	
	35	112,8 (6.88)	2400	210 (3000)	230,8 (60)	98,5 (132)	
	38	121,6 (7.42)	2400	210 (3000)	250,0 (65)	104,4 (140)	
45VQ	42	138,7 (8.46)	2200	175 (2500)	255,8 (66.5)	91,4 (122.5)	34,1 (75)
	50	162,3 (9.90)	2200	175 (2500)	303,8 (79)	105,2 (141)	
	60	193,4 (11.80)	2200	175 (2500)	369,2 (96)	126,8 (170)	

Performance constants: SAE 10W fluid @ 82°C (180°F), and pump inlet @ 0 PSIG (14.7 PSIA)

Note: Outlet pressure must always be higher than inlet pressure.
See page 7 for details.

Model Codes

Single Pump

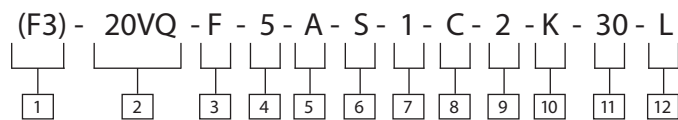

1 F3 – Viton seals
Omit if not required.

2 Intravane pump series

3 Integral valve options
Omit if not required
F – Flow control and relief
P – Priority valve and relief

4 Geometric displacement
Code = SAE rating (USgpm) at
1200 r/min, 7 bar (100 psi)

Code	cm ³ /r	in ³ /r
5	18,0	1.10
8	27,4	1.67
11	36,4	2.22
12	39,5	2.41
14	45,9	2.80

5 Port connections

Series	Code	Inlet	Outlets
20VQ	A	SAE 4-bolt flg.	SAE 4-bolt flg.
20VQ	AM*	Metric 4-bolt flg.	Metric 4-bolt flg.
20VQF&P	B	SAE Str. thd.	SAE Str. thd.
20VQF&P	C	SAE 4-bolt flg.	SAE Str. thd.

* Same as code "A" port connections, except metric threads for fastening flanges.

6 Mounting & shaft seal assembly
F – Foot mount with single shaft seal

S – Flange mount and double shaft seal
Omit for flange mount with single shaft seal.

7 Shaft type
1 – Straight keyed
151 – Splined

8 Outlet positions
(Viewed from cover end of pump)

A – Opposite inlet port
B – 90° CCW from inlet
C – In line with inlet
D – 90° CW from inlet

9 Controlled flow rate
(20VQF & 20VQP)

3 – 11 L/min (3 USgpm)
4 – 15 L/min (4 USgpm)
6 – 23 L/min (6 USgpm)
7 – 27 L/min (7 USgpm)
8 – 30 L/min (8 USgpm)
10 – 38 L/min (10 USgpm)
11 – 42 L/min (11 USgpm)
12 – 45 L/min (12 USgpm)

10 Relief valve setting
(20VQF & 20VQP)
bar (psi)

A – 17 (250)	F – 100 (1500)
B – 35 (500)	G – 121 (1750)
C – 52 (750)	H – 140 (2000)
D – 70 (1000)	J – 155 (2250)
E – 86 (1250)	K – 175 (2500)

11 Design
Subject to change. Installation dimensions remain the same for designs –30 through –39.

12 Shaft Rotation
(Viewed from shaft end of pump)
L – Left hand or counterclockwise.
Omit for right hand.

NOTE: For options other than listed above, i.e. shafts, ports, displacements, and mountings, contact your Danfoss representative.

Model Codes

Single Pump

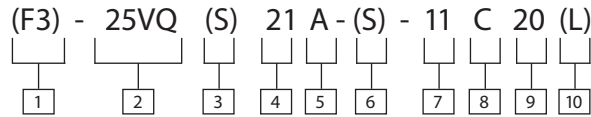

1 F3 - Viton seals
Omit if not required.

2 Intravane pump series

Standard bearing	Heavy duty bearing
25VQ	26VQ
35VQ	36VQ
45VQ	-

3 Pilot designation
S – SAE per ISO 3019/1 (SAE J744)
Omit for standard pilot.

4 Geometric displacement
Code = SAE rating (USgpm) at 1200 r/min and 7 bar (100 psi)
Frame

Size	Code	cm ³ /r	in ³ /r
25V	12	40,2	2.45
	14	45,4	2.77
	17	55,2	3.37
	21	67,5	4.12
35V	25	81,6	4.98
	30	97,7	5.96
	35	112,8	6.88
	38	121,6	7.42
45V	42	138,7	8.46
	50	162,3	9.90
	60	193,4	11.80

5 Port connections

Series	Code	Inlet	Outlets
All	A	SAE 4-bolt flg.	SAE 4-bolt flg.
All	AM*	Metric 4-bolt flg.	Metric 4-bolt flg.
25VQ	B	SAE str. thd.	SAE str. thd.
25VQ	C	SAE 4-bolt flg.	SAE str. thd.
25VQ	D	SAE str. thd.	SAE 4-bolt flg.

*Same as code "A" port connections, except metric threads for fastening flanges.

6 Mounting & shaft seal assembly

F – Foot mounting with single shaft seal

S – Flange mount and double shaft seal

Omit for flange mount with single shaft seal.

7 Shaft type

With standard pilot, single shaft seal

1 – Straight keyed

11 – Splined

86 – Straight keyed, heavy duty

With standard pilot, double shaft seal

123 – Splined (not available on 45VQ)

130 – Splined (for 45VQ only)

With SAE pilot, single or double shaft seal

203 – Straight keyed, heavy duty

297 – Splined

8 Outlet positions
(Viewed from cover end of pump)

A – Opposite inlet

B – 90° CCW from inlet

C – In line with inlet

D – 90° CW from inlet

9 Design
Subject to change. Installation dimensions remain the same for designs –20 through –29

10 Rotation
(Viewed from shaft end of pump)

L – Left hand (counterclockwise)

Omit for right hand.

NOTE: For options other than listed in the model code, i.e. shafts, ports, displacements and mountings, contact your Danfoss representative.

Installation Dimensions

20VQ Series

Dimensions in millimeters (inches).

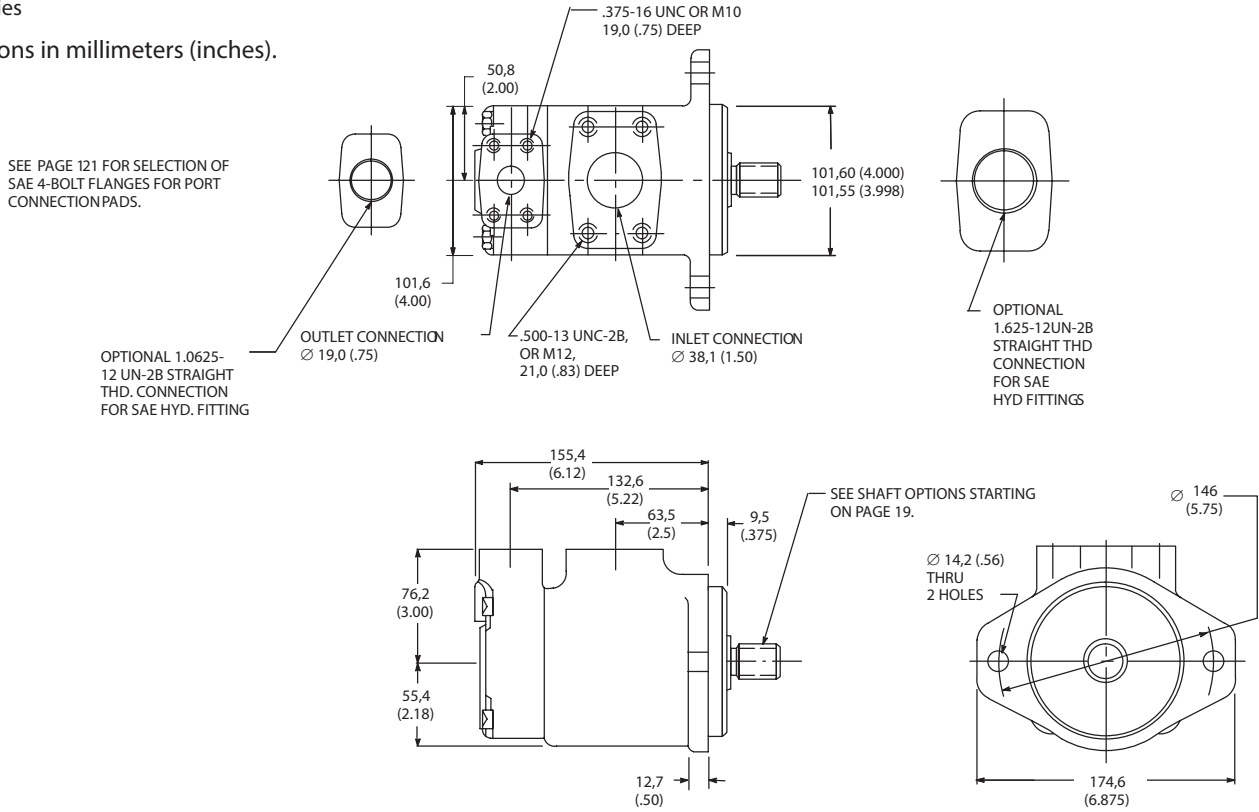

20VQF Series

Additional dimensions are shown above.

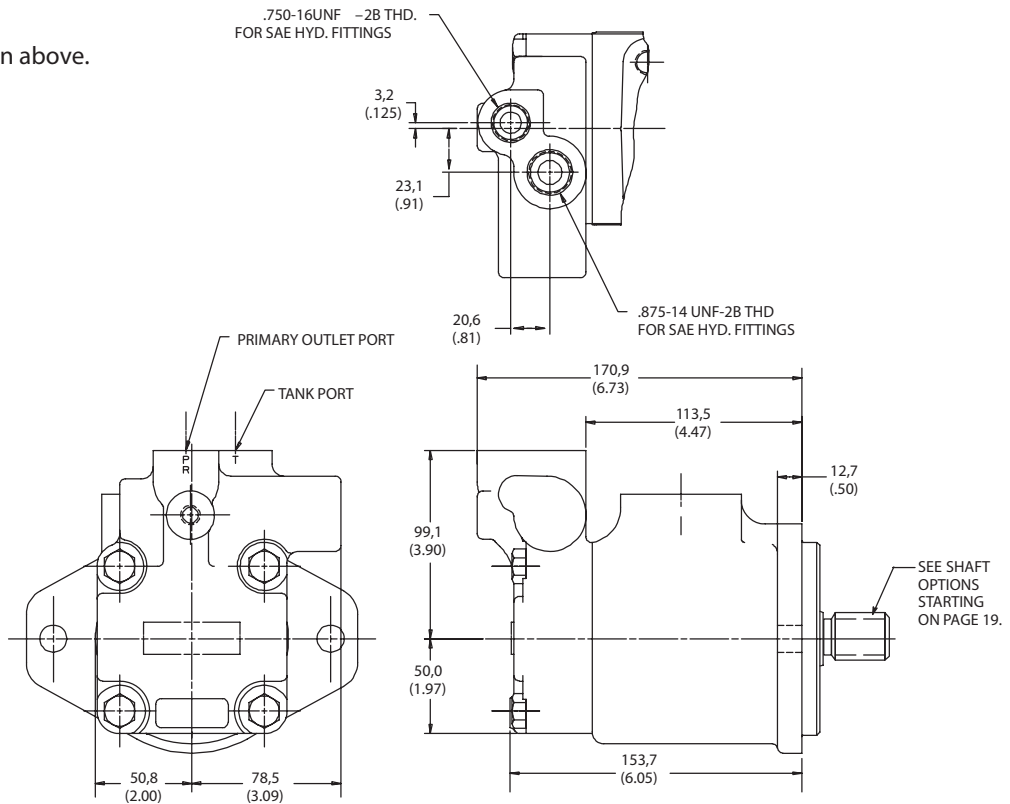

Installation Dimensions

20VQP Series

Dimensions in millimeters (inches)

See preceding page for additional dimensions.

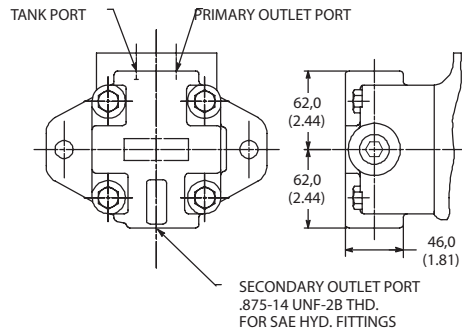
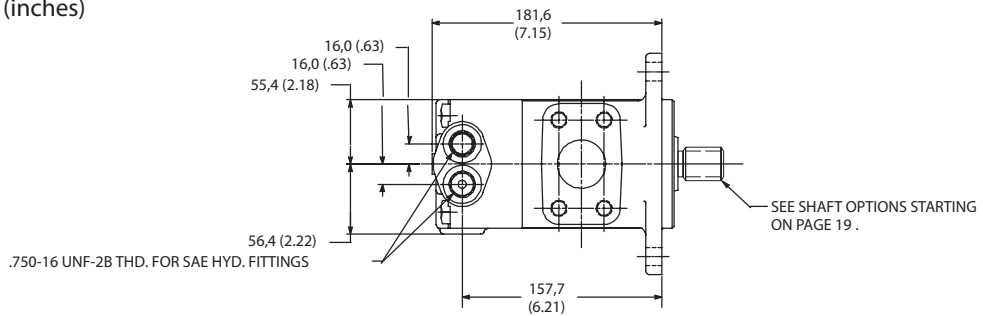

25VQ Series

Dimensions in millimeters (inches)

PORT CONNECTION PADS ARE FOR USE WITH 4-BOLT FLANGES. SEE PAGE 121 FOR SELECTION.

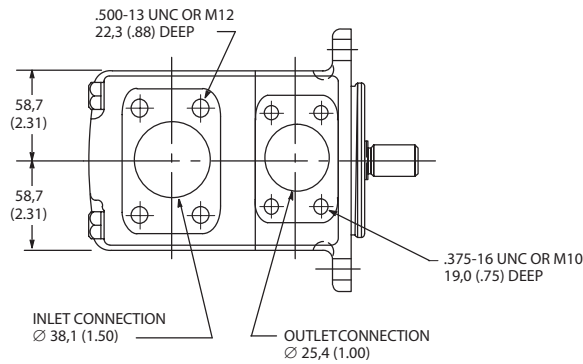

76,2 (3.00) FOR SAE 4-BOLT FLANGE PADS. 85,9 (3.38) FOR 1.875-12 STRAIGHT THREADED INLET AND 1.312-12 OUTLET. SEE MODEL CODE, PAGE 15.

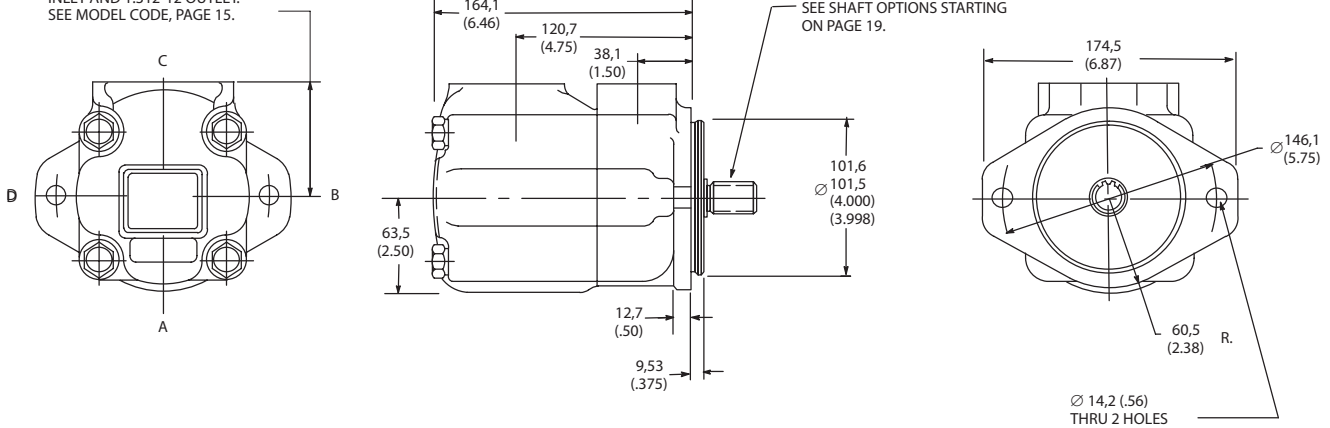

35VQ Series

Dimensions in millimeters (inches)

PORT CONNECTIONPADS ARE FOR USE WITH 4-BOLT FLANGES. SEE PAGE 119 FOR SELECTION.

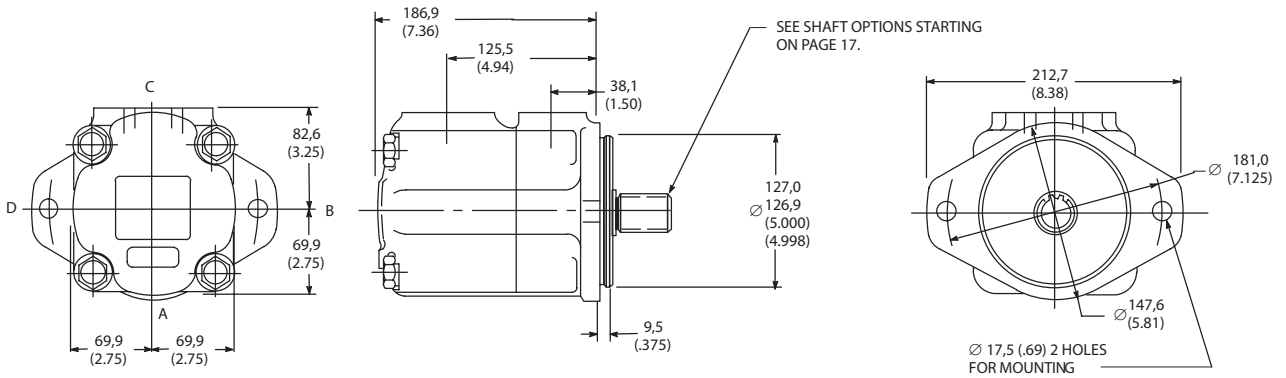
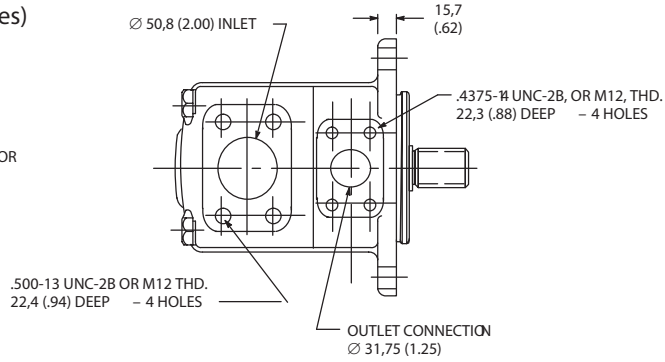

45VQ Series

Dimensions in millimeters (inches)

PORT CONNECTIONPADS ARE FOR USE WITH 4-BOLT FLANGES. SEE PAGE 121 FOR SELECTION.

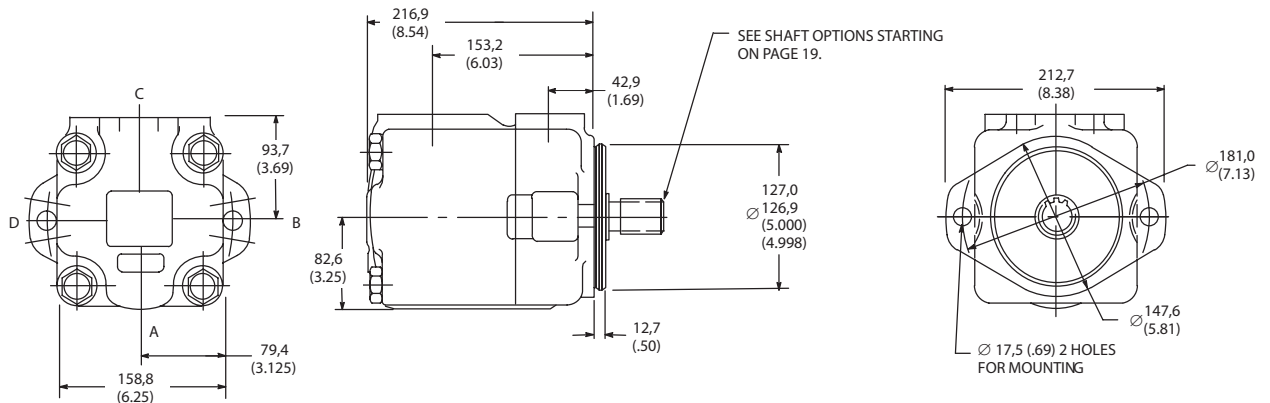
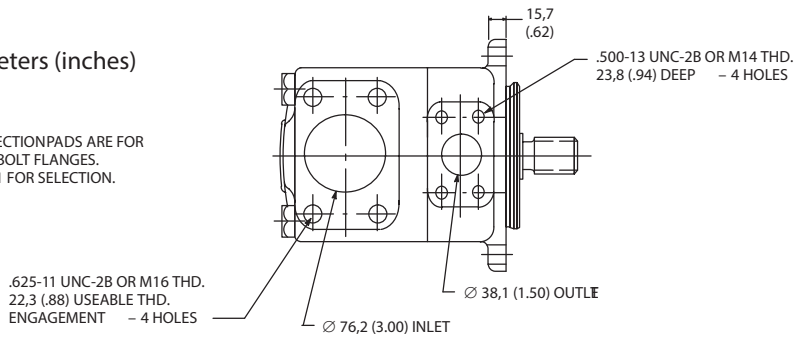

Optional Shafts

Splined Shafts

Dimensions in millimeters (inches)

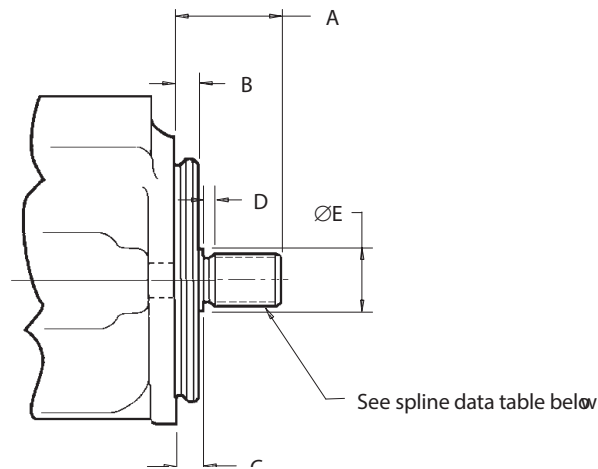

Pump	Shaft Code	A	B	C	D	ØE	Spline Data (See below w.)
20VQ, 20VQF, 20VQP	151	44,1 (1.62)	9,53 (.375)	11,9 (.468)	4,1 (.16)	27,8 (1.09)	A
	11	44,5 (1.75)	9,53 (.375)	11,1 (.437)	4,1 (.16)	27,8 (1.09)	A
25VQ	123	44,5 (1.75)	9,53 (.375)	15,7 (.62)	4,1 (.16)	27,8 (1.09)	A
	297	41,1 (1.62)	9,53 (.375)	7,9 (.31)	4,1 (.16)	27,8 (1.09)	C
35VQ	11	58,7 (2.31)	9,53 (.375)	11,1 (.437)	6,4 (.25)	35,1 (1.38)	D
	123	58,7 (2.31)	9,53 (.375)	15,2 (.60)	5,5 (.21)	35,1 (1.38)	D
	297	55,5 (2.19)	12,7 (.500)	7,9 (.31)	6,4 (.25)	35,1 (1.38)	E
45VQ	11	61,9 (2.44)	12,7 (.500)	14,3 (.565)	9,7 (.38)	39,6 (1.56)	D
	130	61,9 (2.44)	12,7 (.500)	15,2 (.60)	9,9 (.39)	40,4 (1.59)	D
	297	55,5 (2.19)	12,7 (.500)	7,9 (.31)	9,7 (.38)	39,6 (1.56)	E

Spline Data Table

(Involute splines from above chart)

Spline Data Reference	Number of Teeth	Pitch	Major Diameter	Form Diameter	Minor Diameter	Minor Diameter
A	13	16/32	22,17 (.873) 22,15 (.872)	19,03 (.749)	18,16 (.715)	Major dia. fit
C	13	16/32	21,8 (.858) 21,6 (.852)	19,03 (.749)	18,16 (.715)	Side fit
D	14	12/24	31,70 (1.248) 31,67 (1.247)	27,4 (1.08)	26,42 (1.040)	Major dia. fit
E	14	12/24	31,2 (1.229) 31,1 (1.223)	27,4 (1.08)	26,42 (1.040)	Side fit

Straight Key Shafts

Dimensions in millimeters (inches)

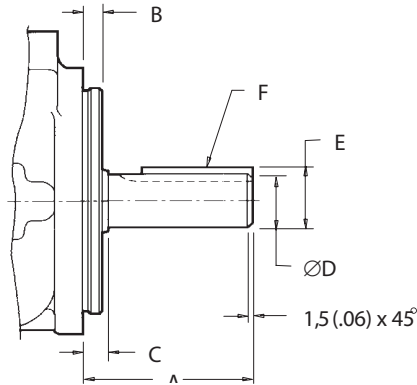

Pump	Shaft Code	A	B	C	ØD	E	F key width x length
20VQ, 20VQF, 20VQP	1	58,7 (2.31)	9,53 (.375)	11,9 (.468)	22,23 (.875) 22,20 (.874)	24,5 (.966) 24,4 (.961)	4,75 (.187) x 32 (1.25)
	1	58,7 (2.31)	9,53 (.375)	11,1 (.435)	22,23 (.875) 22,20 (.874)	24,5 (.966) 24,4 (.961)	4,75 (.187) x 32 (1.25)
25VQ	86	77,7 (3.06)	9,53 (.375)	11,1 (.435)	25,37 (.999) 25,35 (.998)	28,3 (1.11) 28,1 (1.10)	6,36 (.250) x 50,8 (2.00)
	203	77,7 (3.06)	9,53 (.375)	7,9 (.31) ▲	25,40 (1.00) 25,35 (.998)	28,20 (1.11) 27,94 (1.10)	6,36 (.250) x 49,2 (1.938)
35VQ	1	73,2 (2.88)	9,53 (.375)	11,1 (.435)	31,75 (1.250) 31,70 (1.248)	35,36 (1.39) 34,10 (1.38)	7,94 (.313) x 38,1 (1.50)
	86	85,9 (3.38)	9,53 (.375)	11,1 (.435)	34,90 (1.374) 34,87 (1.373)	38,6 (1.52) 38,3 (1.51)	7,92 (.312) x 54 (2.13)
45VQ	203	84,1 (3.31)	12,7 (.500)	7,9 (.31) ▲	34,90 (1.374) 34,87 (1.373)	38,6 (1.52) 38,3 (1.51)	7,92 (.312) x 54 (2.125)
	1	62,0 (2.44)	12,7 (.500)	14,22 (.560)	31,75 (1.250) 31,70 (1.248)	35,36 (1.39) 34,10 (1.38)	7,92 (.312) x 28,5 (1.12)
45VQ	86	87,4 (3.44)	12,7 (.500)	14,22 (.560)	38,07 (1.499) 38,05 (1.498)	42,4 (1.67) 42,1 (1.66)	9,53 (.375) x 50,8 (2.00)
	203	90,4 (3.56)	12,7 (.500)	7,9 (.31) ▲	38,07 (1.499) 38,05 (1.498)	42,4 (1.67) 42,1 (1.66)	9,53 (.375) x 57,1 (2.25)

▲ Shaft shoulder inside recess in pilot.

Typical Performance

20VQ Single Pumps

Performance Constants:
 SAE 10W fluid @ 82° C (180° F)
 Pump inlet @ 0 psig (14.7 psia)

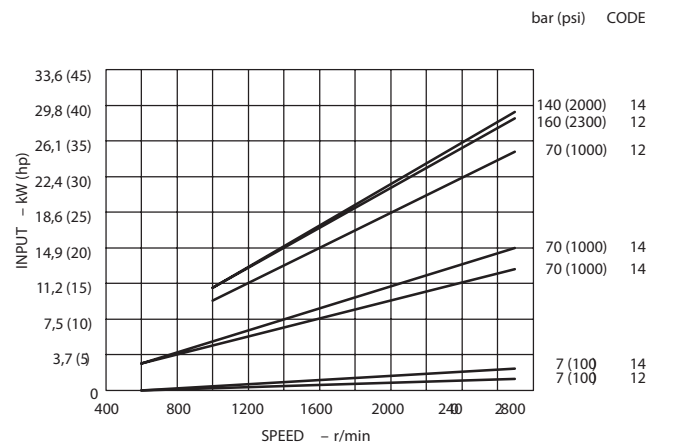
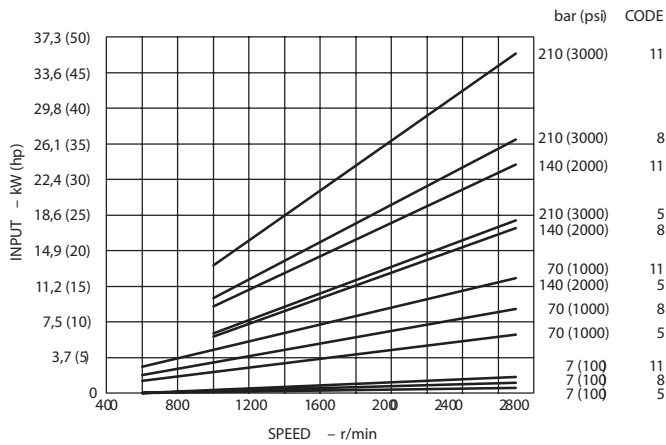
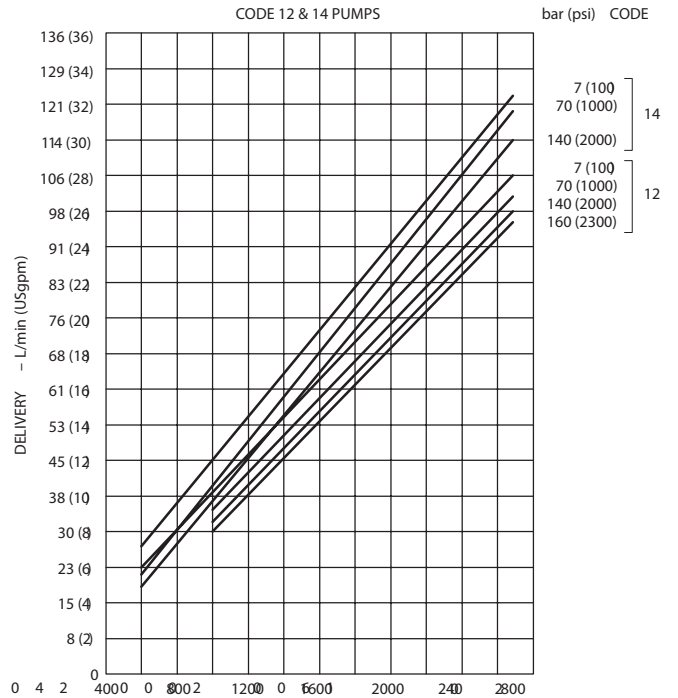
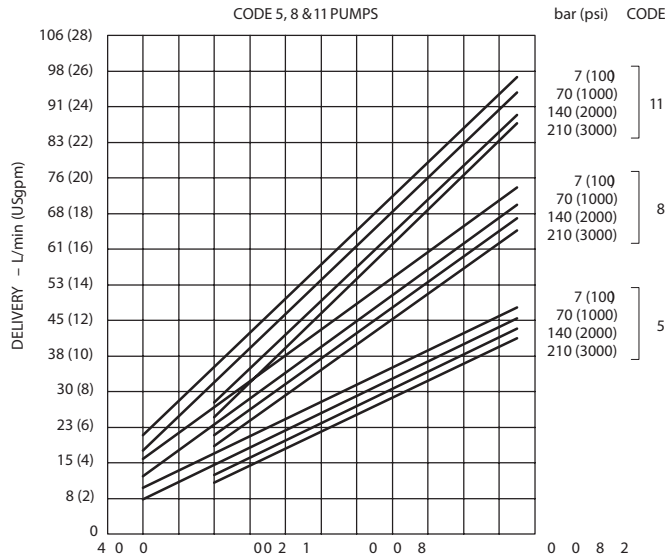

25VQ Single & 25VQT*S Thru-drive Pumps

Performance Constants:
 SAE 10W fluid @ 82 °C (180 °F)
 Pump inlet @ 0 psig (14.7 psia)

Maximum operating speeds shown on performance curves are for pumps operating at 0 psi inlet condition. To compute maximum operating speeds at other inlet conditions, use appropriate speed rating correction factor.

Example:

Max. speed @ 0 psi inlet 2700 r/min
 Correction factor @ 5 in. Hg $\times .93$
 Max. speed @ 5 in. Hg inlet 2511 r/min

Pump inlet suction should not exceed 5 in. Hg vacuum. Positive pressure on inlet should not exceed 1,4 bar (20 psi).

MAXIMUM OPERATING SPEED CORRECTION FACTORS BASED ON PUMP INLET CONDITIONS

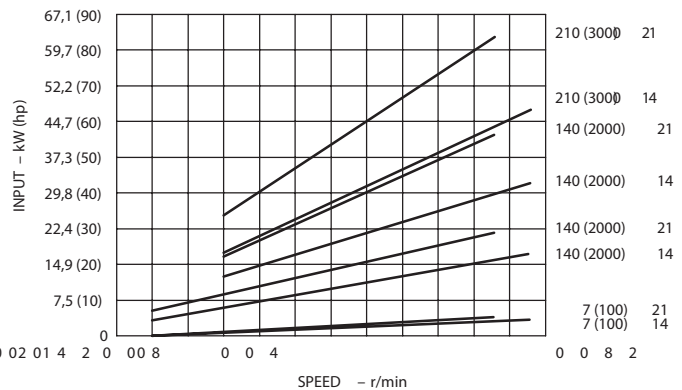
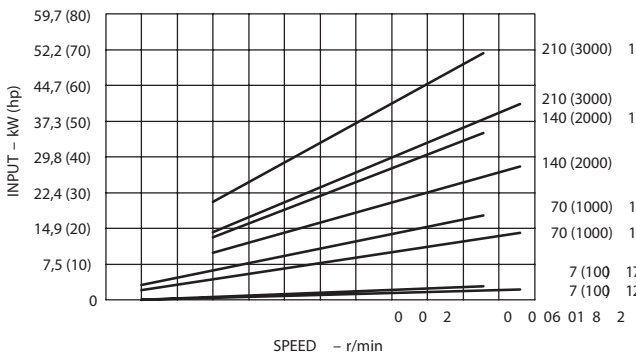
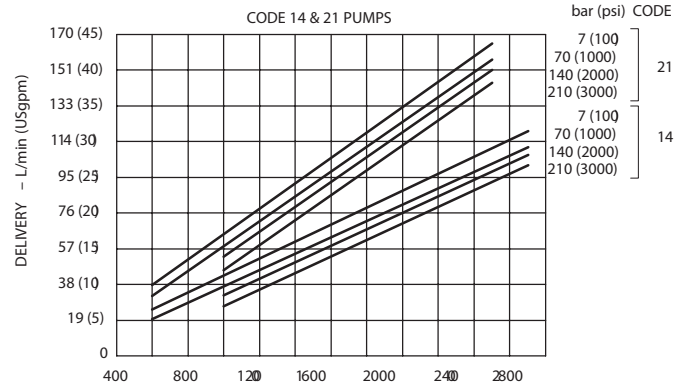
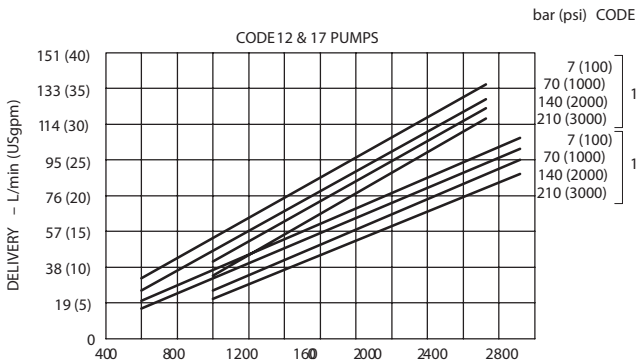
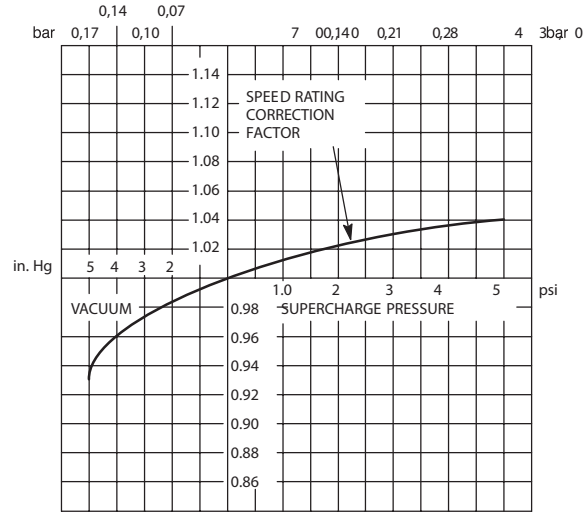

Typical Performance

35VQ Single & 35VQT*S Thru-drive Pumps

Performance Constants:

SAE 10W fluid @ 82 °C (180 °F)

Pump inlet @ 0 psig (14.7 psia)

Maximum operating speeds shown on performance curves are for pumps operating at 0 psi inlet condition. To compute maximum operating speeds at other inlet conditions, use appropriate speed rating correction factor.

Example:

Max. speed @ 0 psi inlet 2500 r/min

Correction factor @ 5 in. Hg $\times .92$

Max. speed @ 5 in. Hg inlet 2300 r/min

Pump inlet suction should not exceed 5 in. Hg vacuum. Positive pressure on inlet should not exceed 1,4 bar (20 psi).

MAXIMUM OPERATING SPEED CORRECTION FACTORS BASED ON PUMP INLET CONDITIONS

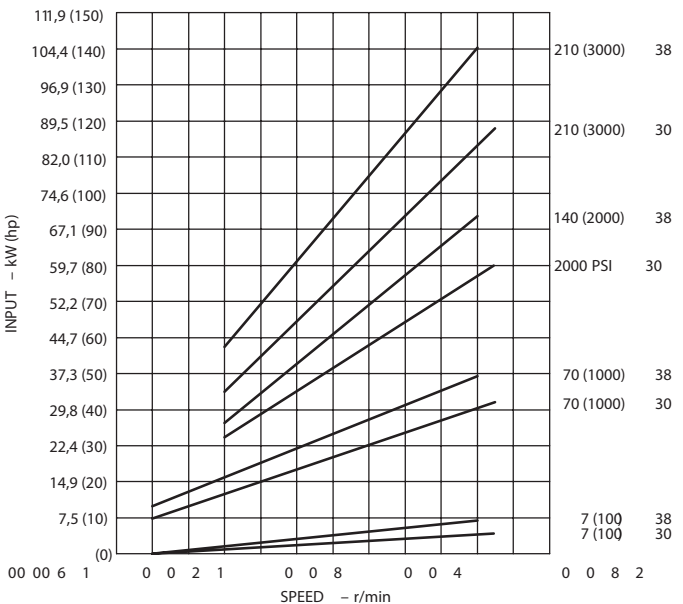
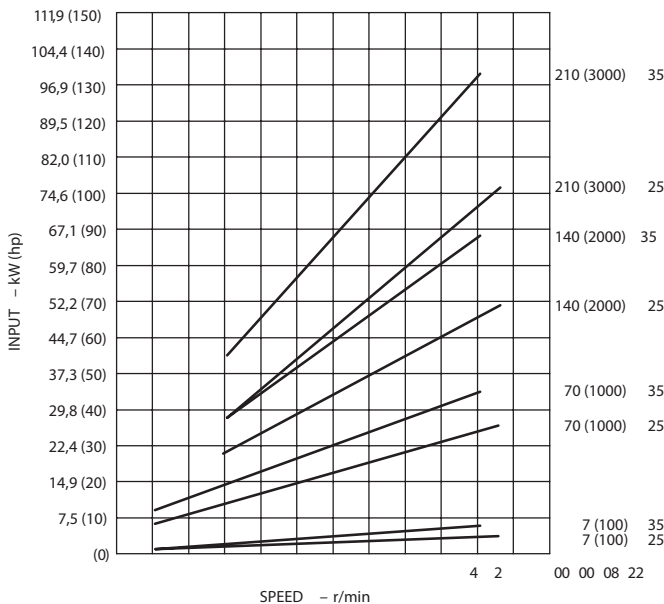
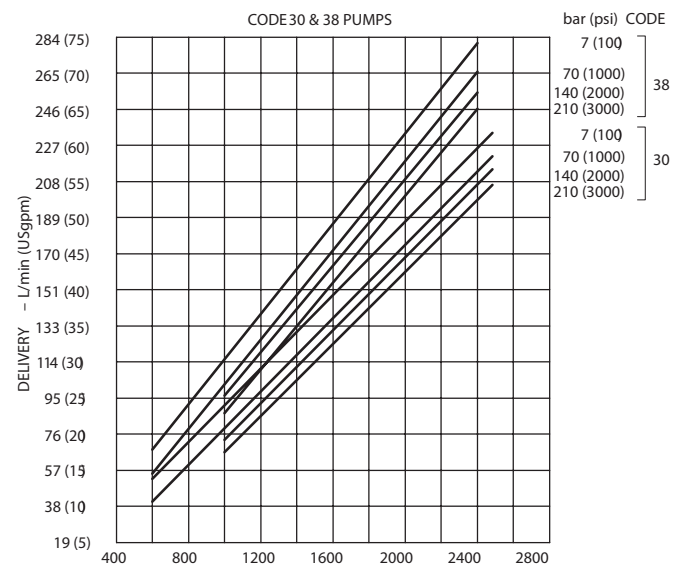
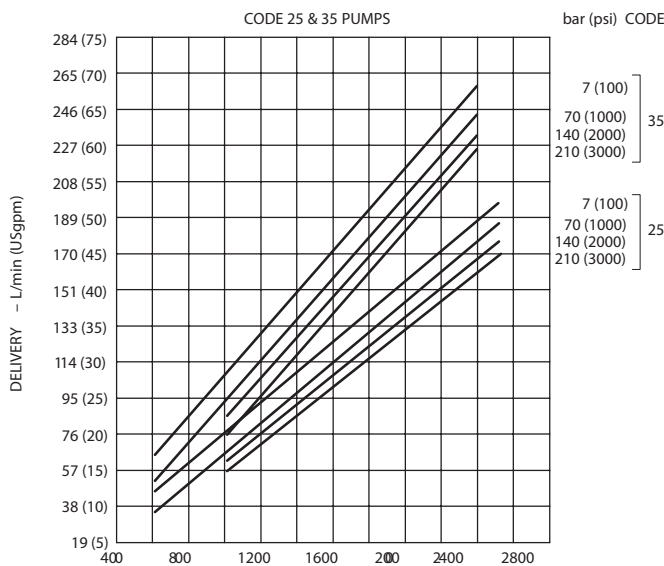
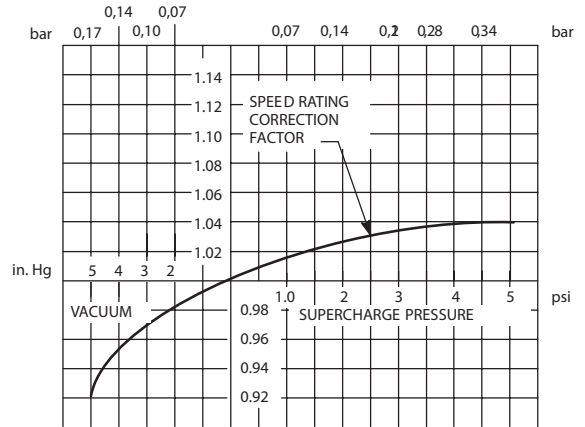

45VQ Single & 45VQT*S Thru-drive Pumps

Performance Constants:
 SAE 10W fluid @ 82 °C (180 °F)
 Pump inlet @ 0 psig (14.7 psia)

Maximum operating speeds shown on performance curves are for pumps operating at 0 psi inlet condition. To compute maximum operating speeds at other inlet conditions, use appropriate speed rating correction factor.

Example:

Max. speed @ 0 psi inlet 2200 r/min
 Correction factor @ 5 in. Hg $\times .91$
 Max. speed @ 5 in. Hg inlet 2002 r/min

Pump inlet suction should not exceed 5 in. Hg vacuum. Positive pressure on inlet should not exceed 1,4 bar (20 psi).

MAXIMUM OPERATING SPEED CORRECTION FACTORS BASED ON PUMP INLET CONDITIONS

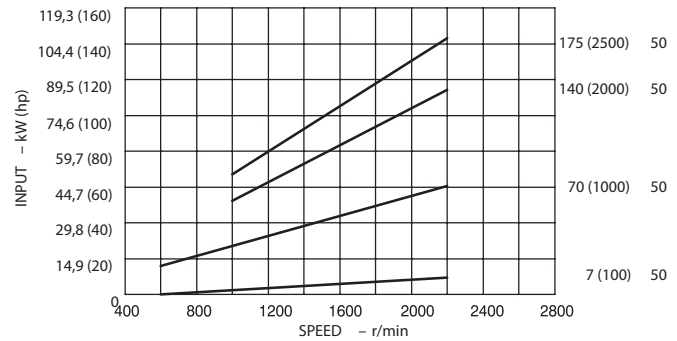
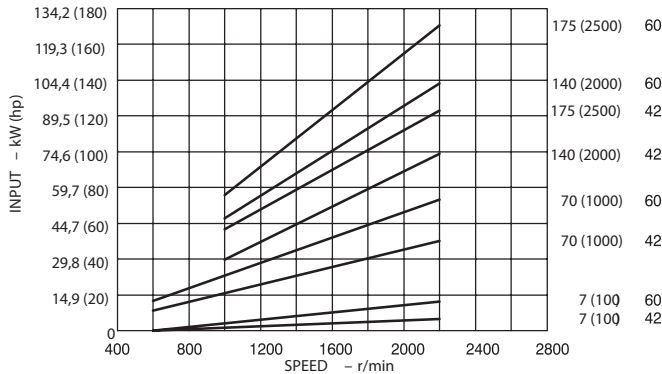
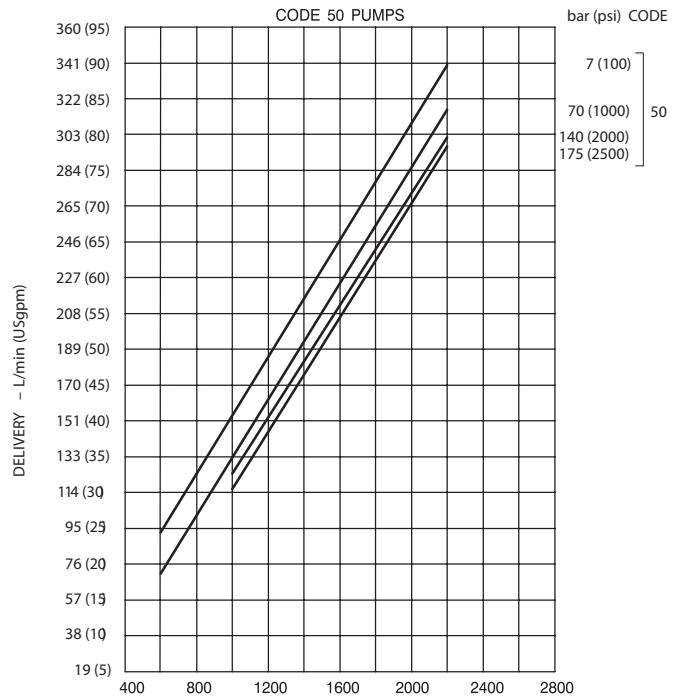
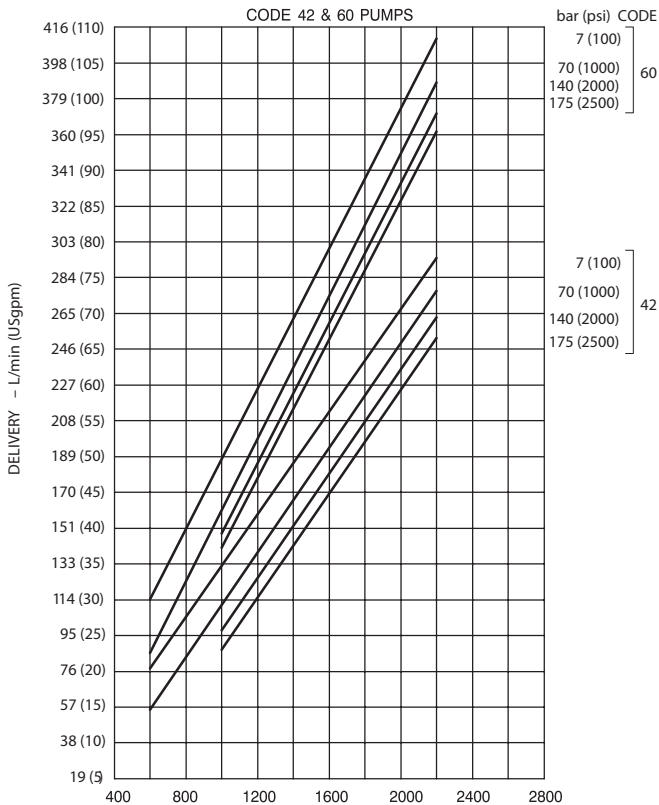
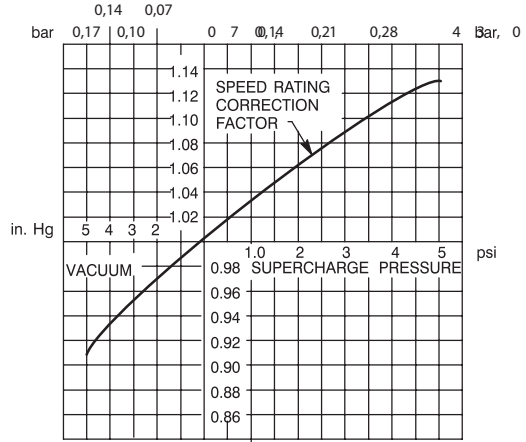

Double Pump Operating Specifications

Model Series	Shaft End Pump					Cover End Pump							Wt. kg (lb.)
	Delivery USgpm @ 1200 r/min 7 bar (100 psi)	Displ. cm ³ /r (in ³ /r)	Max. r/min	Max. bar (psi)	Typical del. L/min (USgpm) @ max. speed & pressure	Typical input kW (hp) @ max. speed & pressure	Delivery USgpm @ 1200 r/min 7 bar (100 psi)	Displ. cm ³ /r (in ³ /r)	Max. r/min	Max. bar (psi)	Typical del. L/min (USgpm) @ max. speed & pressure	Typical input kW (hp) @ max. speed & pressure	
2520VQ	12	40,2 (2.45)	2700	210 (3000)	88,5 (23)	41,0 (55)	5	18,0 (1.10)	2700	210 (3000)	42,3 (11)	17,9 (24)	20,5 (45)
	14	45,4 (2.77)	2700	210 (3000)	103,8 (27)	46,6 (62.5)	8	27,4 (1.67)	2700	210 (3000)	65,4 (17)	26,1 (35)	
	17	55,2 (3.37)	2500	210 (3000)	119,2 (31)	51,8 (69.5)	11	36,4 (2.22)	2700	210 (3000)	88,5 (23)	35,4 (47.5)	
	21	67,7 (4.12)	2500	210 (3000)	146,2 (38)	61,9 (83)	12	39,5 (2.41)	2700	160 (2300)	98,1 (25.5)	28,4 (38)	
3520VQ	25	81,6 (4.98)	2500	210 (3000)	173,1 (45)	75,3 (101)	5	18,0 (1.10)	2500	210 (3000)	38,5 (10)	16,5 (22)	34,0 (75)
	30	97,7 (5.96)	2500	210 (3000)	211,5 (55)	87,7 (117.5)	8	27,4 (1.67)	2500	210 (3000)	61,5 (16)	24,0 (32.5)	
	35	112,8 (6.88)	2400	210 (3000)	230,8 (60)	98,5 (132)	11	36,4 (2.22)	2500	210 (3000)	80,8 (21)	33,0 (44)	
	38	121,6 (7.42)	2400	210 (3000)	250,0 (65)	104,4 (140)	12	39,5 (2.41)	2500	160 (2300)	90,4 (23.5)	26,1 (35)	
3525VQ	25	81,6 (4.98)	2500	210 (3000)	173,1 (45)	75,3 (101)	12	40,2 (2.45)	2500	210 (3000)	79,5 (21)	38,0 (51)	34,5 (76)
	30	97,7 (5.96)	2500	210 (3000)	211,5 (55)	87,7 (117.5)	14	45,4 (2.77)	2500	210 (3000)	91,0 (24)	43,0 (58)	
	35	112,8 (6.88)	2400	210 (3000)	230,8 (60)	98,5 (132)	17	55,2 (3.37)	2500	210 (3000)	119,2 (31)	51,5 (69)	
	38	121,6 (7.42)	2400	210 (3000)	250,0 (65)	104,4 (140)	21	67,5 (4.12)	2500	210 (3000)	146,2 (38)	61,9 (83)	
4520VQ	42	138,7 (8.46)	2200	175 (2500)	255,8 (66.5)	91,4 (122.5)	5	18,0 (1.10)	2200	210 (3000)	32,0 (8.5)	14,5 (19.5)	43,0 (94)
	50	162,3 (9.90)	2200	175 (2500)	303,8 (79)	105,2 (141)	8	27,4 (1.67)	2200	210 (3000)	51,0 (13.5)	21,0 (28.5)	
	60	193,4 (11.80)	2200	175 (2500)	369,2 (96)	126,8 (170)	11	36,4 (2.22)	2200	210 (3000)	68,0 (18)	28,5 (38.5)	
							12	39,5 (2.41)	2200	160 (2300)	77,5 (20.5)	23,0 (31)	
4525VQ	42	138,7 (8.46)	2200	175 (2500)	255,8 (66.5)	91,4 (122.5)	12	40,2 (2.45)	2200	210 (3000)	68,0 (18)	33,0 (44)	46,0 (101)
	50	162,3 (9.90)	2200	175 (2500)	303,8 (79)	105,2 (141)	14	45,4 (2.77)	2200	210 (3000)	79,5 (21)	38,0 (51)	
	60	193,4 (11.80)	2200	175 (2500)	369,2 (96)	126,8 (170)	17	55,2 (3.37)	2200	210 (3000)	100,0 (26.5)	45,5 (61)	
							21	67,5 (4.12)	2200	210 (3000)	125,0 (33)	54,5 (73)	
4535VQ	42	138,7 (8.46)	2200	175 (2500)	255,8 (66.5)	91,4 (122.5)	25	81,6 (4.98)	2200	210 (3000)	145,5 (38.5)	66,5 (89)	53,6 (118)
	50	162,3 (9.90)	2200	175 (2500)	303,8 (79)	105,2 (141)	30	97,7 (5.96)	2200	210 (3000)	178,0 (47)	77,5 (104)	
	60	193,4 (11.80)	2200	175 (2500)	369,2 (96)	126,8 (170)	35	112,8 (6.88)	2200	210 (3000)	211,5 (55)	89,5 (120)	
							38	121,6 (7.42)	2200	210 (3000)	223,0 (59)	97,0 (130)	

Performance constants: SAE 10W fluid @ 120°F; pump inlet @ 0 PSIG (14.7 PSIA)

Note: Outlet pressure must always be higher than inlet pressure. See page 7 for details.

Model Codes

Double Pump (without integral valves)

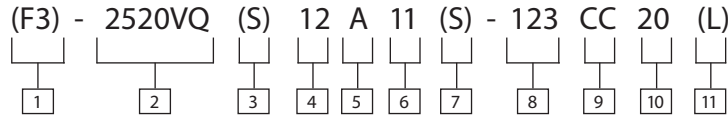

1 F3 - Viton seals

Omit if not required.

2 Intravane pump series

2520VQ	3525VQ	4525VQ
3520VQ	4520VQ	4535VQ

3 Pilot designation

S – SAE per ISO 3019/1 (SAE J744)

Omit for standard pilot.

4 Geometric displacement shaft end pump

Code = SAE rating (USgpm) at 1200 r/min and 7 bar (100 psi)

Frame	Code	Size	(USgpm)	cm ³ /r	in ³ /r
2520VQ	12	14	40,2	2,45	2,45
	14	17	45,4	2,77	2,77
	17	21	55,2	3,37	3,37
	21		67,5	4,12	4,12

35**VQ	25	81,6	4,98
	30	97,7	5,96
	35	112,8	6,88
	38	121,6	7,42

45**VQ	42	138,7	8,46
	50	162,3	9,90
	60	193,4	11,80

Note: For options other than listed in the model code, i.e. shafts, ports, displacements and mountings, contact your Danfoss representative.

6 Geometric displacement - cover end pump

Code = SAE rating (USgpm) at 1200 r/min and 7 bar (100 psi)

Frame	Code	Size	(USgpm)	cm ³ /r	in ³ /r
**20VQ	5	8	18,0	1,10	1,10
	8	11	27,4	1,67	1,67
	11	12	36,4	2,22	2,22
	12	14	39,5	2,41	2,41
	14		45,9	2,80	2,80

**25VQ	12	40,2	2,45
	14	45,4	2,77
	17	55,2	3,37
	21	67,5	4,12

4535VQ	25	81,6	4,98
	30	97,7	5,96
	35	112,8	6,88
	38	121,6	7,42

7 Mounting & shaft seal assembly

S – Flange mount and double shaft seal

Omit for flange mount with single shaft seal.

8 Shaft type

With standard pilot, single shaft seal

- 1 – Straight keyed
- 11 – Splined
- 86 – Straight keyed, heavy duty

With standard pilot, double shaft seal

- 123 – S plined (not available on 45**VQ)
- 130 – Splined (for 45**VQ only)

With SAE pilot, single or double shaft seal

- 203 – Straight keyed, heavy duty
- 297 – Splined

9 Port orientation

(Viewed from cover end of pump)

All series except 4535VQ

With No.1 outlet opposite inlet:

AA - No. 2 outlet 135 ° CCW from inlet

AB - No. 2 outlet 45 ° CCW from inlet

AC - No. 2 outlet 45 ° CW from inlet

AD - No. 2 outlet 135 ° CW from inlet

With No.1 outlet 90 ° CCW from inlet:

BA - No. 2 outlet 135 ° CCW from inlet

BB - No. 2 outlet 45 ° CCW from inlet

BC - No. 2 outlet 45 ° CW from inlet

BD - No. 2 outlet 135 ° CW from inlet

With No.1 outlet inline with inlet:

CA - No. 2 outlet 135 ° CCW from inlet

CB - No. 2 outlet 45 ° CCW from inlet

CC - No. 2 outlet 45 ° CW from inlet

CD - No. 2 outlet 135 ° CW from inlet

With No.1 outlet 90 ° CW from inlet:

DA - No. 2 outlet 135 ° CCW from inlet

DB - No. 2 outlet 45 ° CCW from inlet

DC - No. 2 outlet 45 ° CW from inlet

DD - No. 2 outlet 135 ° CW from inlet

Series 4535VQ

With No.1 outlet opposite inlet:

AA - No. 2 outlet opposite inlet

AB - No. 2 outlet 90 ° CCW from inlet

AC - No. 2 outlet inline with inlet

AD - No. 2 outlet 90 ° CW from inlet

With No.1 outlet 90 ° CW from inlet:

BA - No. 2 outlet opposite inlet

BB - No. 2 outlet 90 ° CCW from inlet

BC - No. 2 outlet inline with inlet

BD - No. 2 outlet 90 ° CW from inlet

With No.1 outlet inline with inlet:

CA - No. 2 outlet opposite inlet

CB - No. 2 outlet 90 ° CCW from inlet

CC - No. 2 outlet inline inlet

CD - No. 2 outlet 90 ° CW from inlet

With No.1 outlet 90 ° CW from inlet:

DA - No. 2 outlet opposite inlet

DB - No. 2 outlet 90 ° CCW from inlet

DC - No. 2 outlet inline with inlet

DD - No. 2 outlet 90 ° CW from inlet

5 Port connections

Pump series	Code	Inlet	Outlet no.1	Outlet no. 2
All	A	SAE 4-bolt flg	SAE 4-bolt flg.	SAE 4-bolt flg.
All	AM*	Metric 4-bolt flg.	Metric 4-bolt flg.	Metric 4-bolt flg.
2520VQ	C	SAE 4-bolt flg.	SAE str. thd.	SAE str. thd.
All but 4535VQ	E	SAE 4-bolt flg.	SAE 4-bolt flg.	SAE str. thd.
2520VQ	F	SAE 4-bolt flg.	SAE str. thd.	SAE 4-bolt flg.

*Same as code "A" port connections, except metric threads for fastening flanges.

10 Design

11 Shaft Rotation

(Viewed from shaft end of pump)

L – Left hand (counterclockwise)

Omit for right hand.

Model Codes

Double Pump (without integral valves)

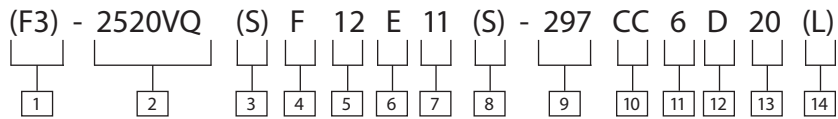

1 F3 - Viton seals
Omit if not required.

2 Intravane pump series
2520VQ 3525VQ 4525VQ

3 Pilot designation
S – SAE per ISO 3019/1 (SAE J744)
Omit for standard pilot.

4 Integral valve options
F – Flow control and relief
P – Priority valve and relief

5 Geometric displacement shaft end pump

Code = SAE rating (USgpm) at 1200 r/min and 7 bar (100 psi)

Frame	Code	Size	(USgpm)	cm ³ /r	in ³ /r
2520VQ	12	40,2	2.45		
	14	45,4	2.77		
	17	55,2	3.37		
	21	67,5	4.12		
3520VQ	25	81,6	4.98		
	30	97,7	5.96		
	35	112,8	6.88		
	38	121,6	7.42		
4520VQ	42	138,7	8.46		
	50	162,3	9.90		
	60	193,4	11.80		

6 Port connections

Pump series	Code	Inlet	Outlet no. 1	Outlet(s) no.	2 Tank
2520VQ only	C	SAE 4-bolt flg.	SAE str. thd.	SAE str. thd.	SAE str. thd.
All pumps	E	SAE 4-bolt flg.	SAE 4-bolt flg.	SAE str. thd.	SAE str. thd.

7 Geometric displacement - cover end pump
Code = SAE rating (USgpm) at 1200 r/min and 7 bar (100 psi)

Frame	Code	Size	(USgpm)	cm ³ /r	in ³ /r
**20VQ	5	18,0	1.10		
	8	27,4	1.67		
	11	36,4	2.22		
	12	39,5	2.41		
	14	45,9	2.80		

8 Mounting & shaft seal assembly
S – Flange mount and double shaft seal
Omit for flange mount with single shaft seal.

9 Shaft type
With standard pilot, single shaft seal
1 – Straight keyed
11 – Splined
86 – Straight keyed, heavy duty

With standard pilot, double shaft seal
123 – Splined (not available on 4520VQ)
130 – Splined (for 4520VQ only)

With SAE pilot, single or double shaft seal
203 – Straight keyed, heavy duty
297 – Splined

10 Port orientation
(Viewed from cover end of pump)
With No.1 outlet opposite inlet:
AA - No. 2 outlet 135 ° CCW from inlet
AB - No. 2 outlet 45 ° CCW from inlet
AC - No. 2 outlet 45 ° CW from inlet
AD - No. 2 outlet 135 ° CW from inlet
With No.1 outlet 90 ° CCW from inlet:
BA - No. 2 outlet 135 ° CCW from inlet
BB - No. 2 outlet 45 ° CCW from inlet
BC - No. 2 outlet 45 ° CW from inlet
BD - No. 2 outlet 135 ° CW from inlet
With No.1 outlet inline with inlet:
CA - No. 2 outlet 135 ° CCW from inlet
CB - No. 2 outlet 45 ° CCW from inlet
CC - No. 2 outlet 45 ° CW from inlet
CD - No. 2 outlet 135 ° CW from inlet
With No.1 outlet 90 ° CW from inlet:
DA - No. 2 outlet 135 ° CCW from inlet
DB - No. 2 outlet 45 ° CCW from inlet
DC - No. 2 outlet 45 ° CW from inlet
DD - No. 2 outlet 135 ° CW from inlet

11 Controlled flow rate – USgpm
2, 4, 6, 7, 8, 10 or 12 USgpm

12 Relief valve setting – bar (psi)
C – 52 (750) G – 121 (1750)
D – 70 (1000) H – 140 (2000)
E – 86 (1250) J – 155 (2250)
F – 100 (1500) K – 175 (2500)

13 Design
(Viewed from shaft end of pump)
L - Left hand (counterclockwise)
Omit for right hand.

14 Shaft Rotation
(Viewed from shaft end of pump)
L – Left hand (counterclockwise)
Omit for right hand.

Note: For options other than listed in the model code, i.e. shafts, ports, displacements and mountings, contact your Danfoss representative.

Installation Dimensions

2520VQ Series

Dimensions in millimeters (inches)

4-BOLT PORT CONNECTION PADS ARE FOR USE WITH 4-BOLT FLANGES. SEE PAGE 121 FOR SELECTION.

OPTIONAL STRAIGHT THREAD CONNECTION 1.0625-12 UN-2B THREAD FOR SAE HYD. FITTINGS



Ø 19,1 (.75)
OUTLET
CONN. NO.2

.375 UNC-2B OR M10 THD.
19,05 (.75) DEEP - 4 HOLES

Ø 63,5 (2.50)
INLET CONN.

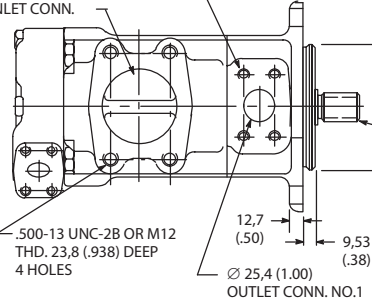

.500-13 UNC-2B OR M12
THD. 23,8 (.938) DEEP
4 HOLES

Ø 25,4 (1.00)
OUTLET CONN. NO.1

101,6

Ø 101,5

(4.000)

(3.998)



OPTIONAL STRAIGHT
THREAD CONNECTION
1.3125-12 UN-2B
THREAD FOR SAE HYD.
FITTINGS

SEE SHAFT OPTIONS
STARTING ON PAGE 32.

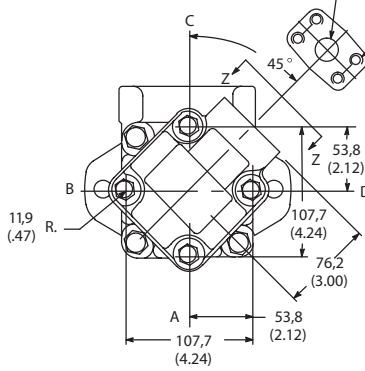

11,9
(.47)

R.

B

D

A

107,7

(4.24)

53,8

(2.12)

107,7

(4.24)

76,2

(3.00)

53,8

(2.12)

45°

Z

Z

53,8

(2.12)

107,7

(4.24)

76,2

(3.00)

107,7

(4.24)

53,8

(2.12)

107,7

(4.24)

76,2

(3.00)

53,8

(2.12)

107,7

(4.24)

76,2

(3.00)

107,7

(4.24)

53,8

(2.12)

107,7

(4.24)

76,2

(3.00)

107,7

(4.24)

53,8

(2.12)

107,7

(4.24)

76,2

(3.00)

.375-16 UNC-2B OR M10 THD.
19,05 (.75) DEEP- 4 HOLES

VIEW Z-Z

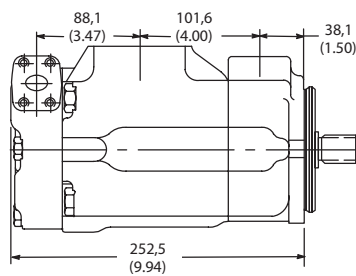

88,1

(3.47)

101,6

(4.00)

38,1

(1.50)

252,5

(9.94)

Ø 120,7 (4.75)

174,8

(6.88)

85,9

(3.38)

84,1

(3.31)

76,2

(3.00)

HEIGHT OF
STRAIGHT
THREAD
CONNECTION

Ø 146,1(5.75)

Ø 14,2 (.56) - 2 HOLES

3520VQ Series

Dimensions in millimeters (inches)

4-BOLT PORT CONNECTION PADS ARE FOR USE WITH 4-BOLT FLANGES. SEE PAGE 121 FOR SELECTION.

OPTIONAL STRAIGHT THREAD CONNECTION 1.0625-12 UN-2B THREAD FOR SAE HYD. FITTINGS

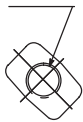

Ø 19,1 (.75)
OUTLET
CONN. NO.2

.625 UNC-2B OR M16 THD.
28,5 (1.125) DEEP- 4 HOLES

Ø 76,2 (3.00)
INLET CONN.

.375-16 UNC-2B OR M10 THD.
19,05 (.75) DEEP- 4 HOLES

.437-14 UNC-2B OR M12 THD
22,2 (.875) DEEP- 4 HOLES

Ø 31,8 (1.25)
OUTLET CONN. NO.1

15,7
(.62)

127,0

Ø 126,9

(5.000)

(4.998)

9,7

(.38)

SEE SHAFT OPTIONS
STARTING ON PAGE 32.

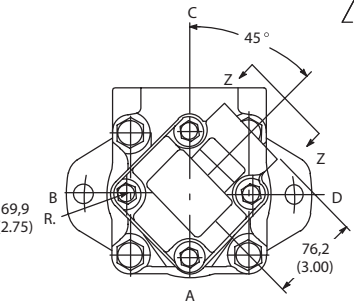

69,9

(2.75)

B

D

A

76,2

(3.00)

45°

Z

Z

69,9

(2.75)

76,2

(3.00)

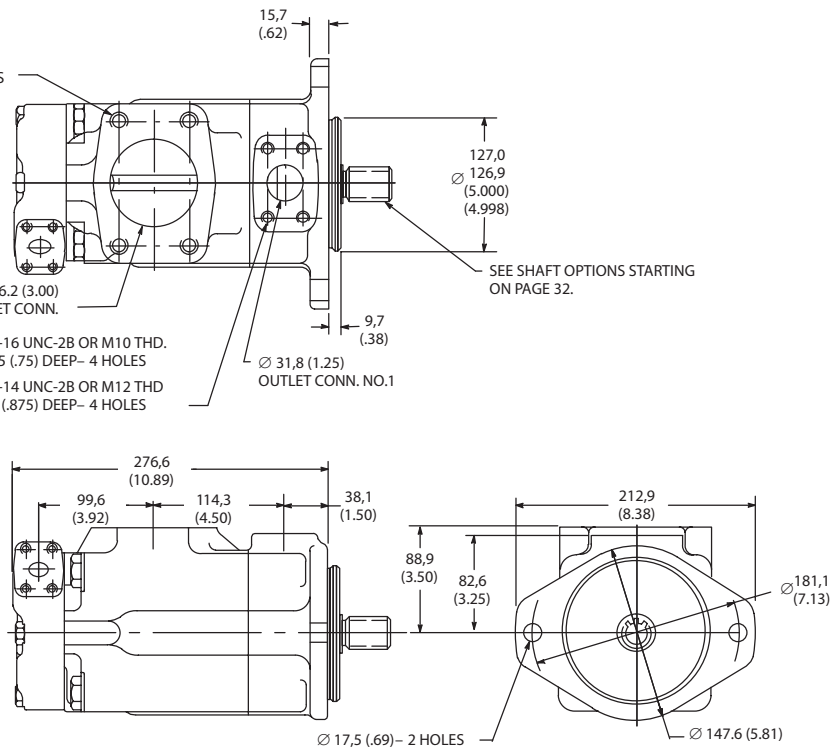

276,6

(10.89)

99,6

(3.92)

114,3

(4.50)

38,1

(1.50)

212,9

(8.38)

88,9

(3.50)

82,6

(3.25)

Ø 181,1

(7.13)

Ø 17,5 (.69) - 2 HOLES

Ø 147,6 (5.81)

Installation Dimensions

3525VQ Series

Dimensions in millimeters (inches)

4-BOLT PORT CONNECTION PADS ARE FOR USE WITH 4-BOLT FLANGES. SEE PAGE 121 FOR SELECTION.

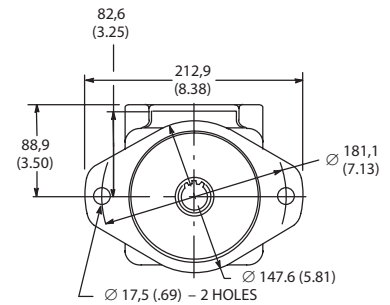
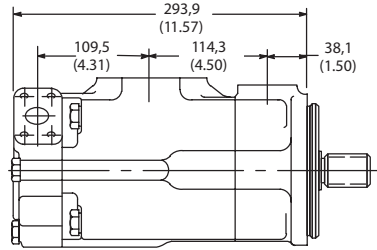
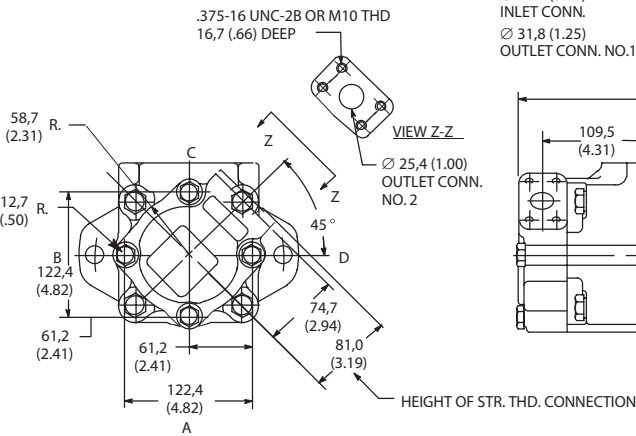
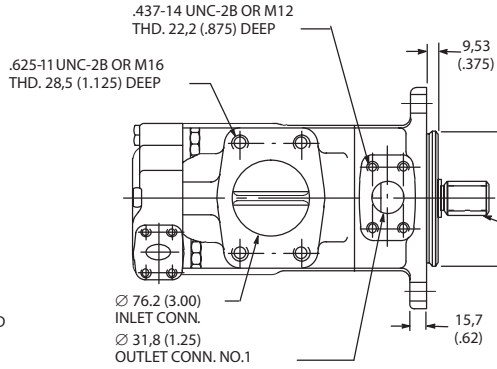
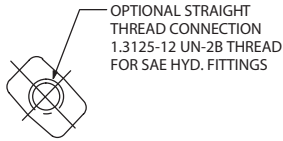

4520VQ Series

Dimensions in millimeters (inches)

4-BOLT PORT CONNECTION PADS ARE FOR USE WITH 4-BOLT FLANGES. SEE PAGE 121 FOR SELECTION.

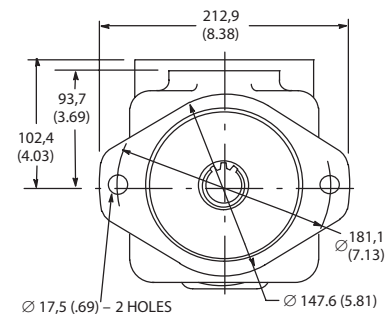
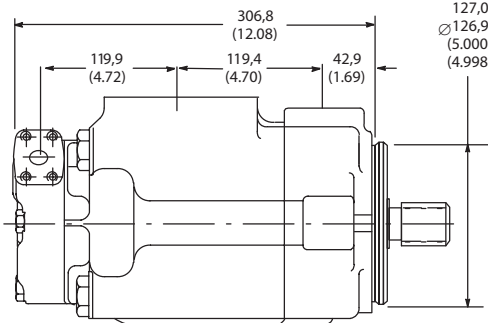
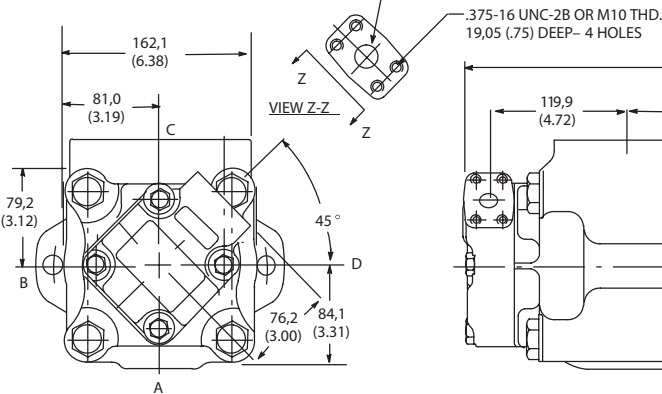
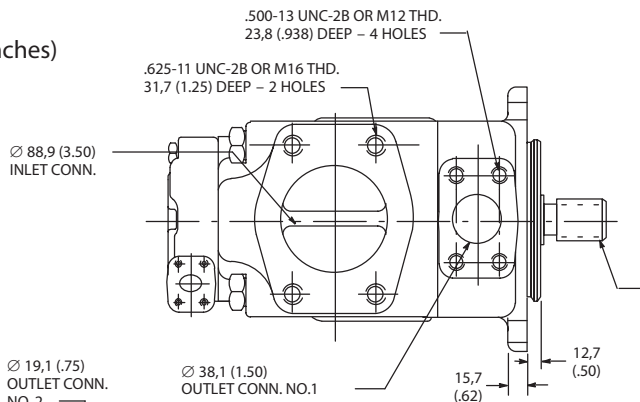
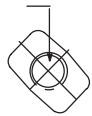

4525VQ Series

Dimensions in millimeters (inches)

4-BOLT PORT CONNECTIONPADS ARE FOR USE WITH 4-BOLT FLANGES. SEE PAGE 121 FOR SELECTION.

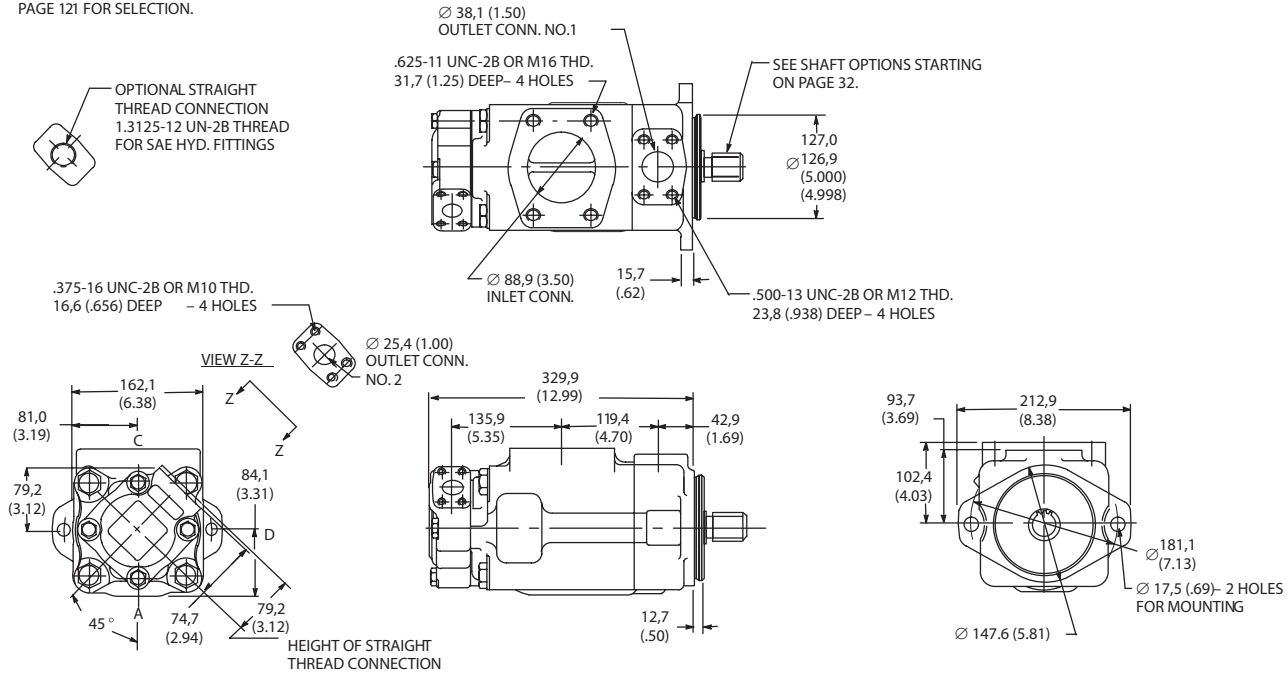

4535VQ Series

Dimensions in millimeters (inches)

PORT CONNECTIONPADS ARE FOR USE WITH 4-BOLT FLANGES. SEE PAGE 121 FOR SELECTION.

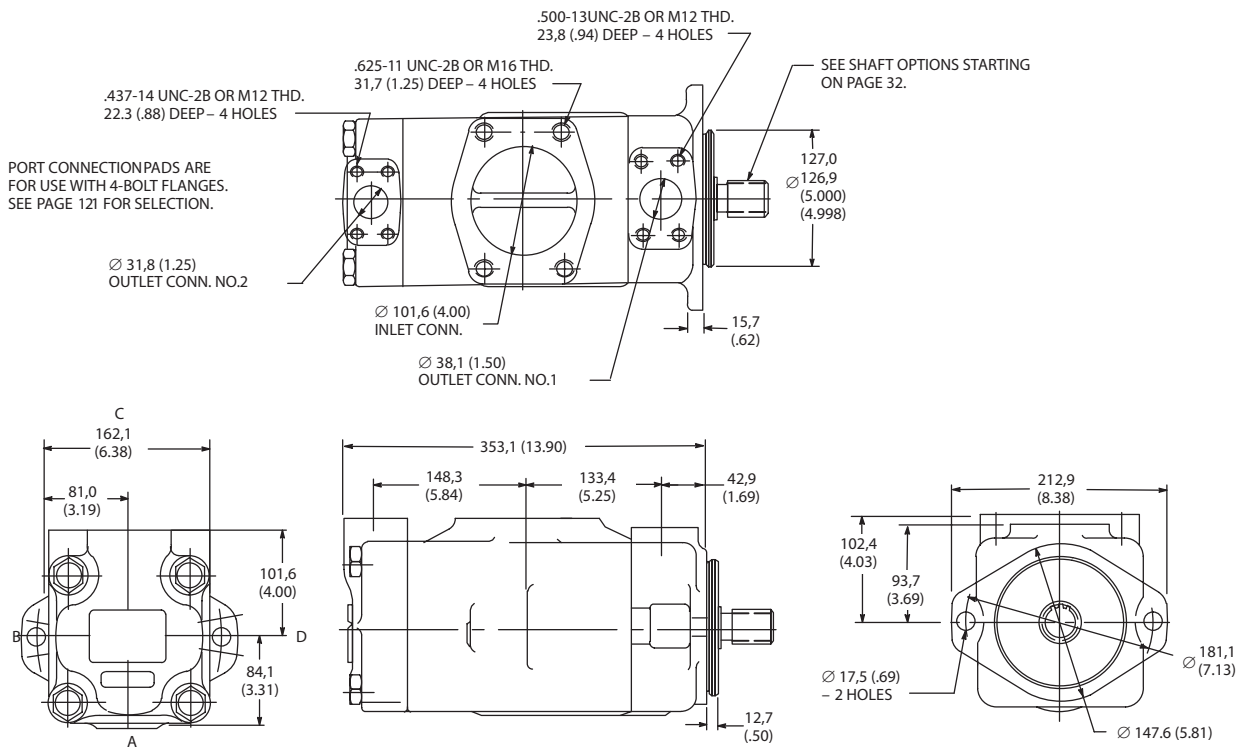

Installation Dimensions

Pumps with flow control cover

Dimensions in millimeters (inches)

Model series	A	B	Dimensions		E
			C	D	
2520VQF	265,9 (10.47)	108,7 (4.28)	88,1 (3.47)	101,6 (4.00)	38,1 (1.50)
3520VQF	289,8 (11.41)	120,1 (4.73)	99,6 (3.92)	114,3 (4.50)	38,1 (1.50)
4520VQF	320,3 (12.61)	140,5 (5.53)	119,9 (4.72)	119,4 (4.70)	42,9 (1.69)

OUTLET CONNECTION NO.2
.750-16 UNF-2B THD.

TANK CONNECTION
.875-14 UNF-2B THD.

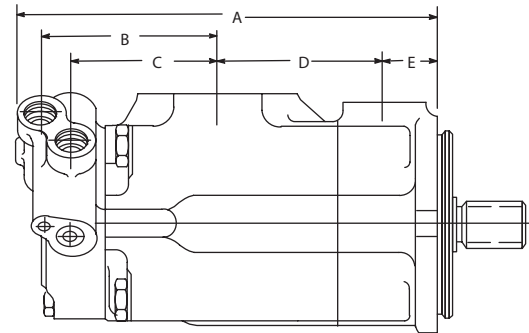
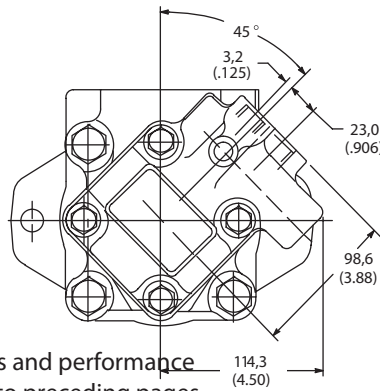
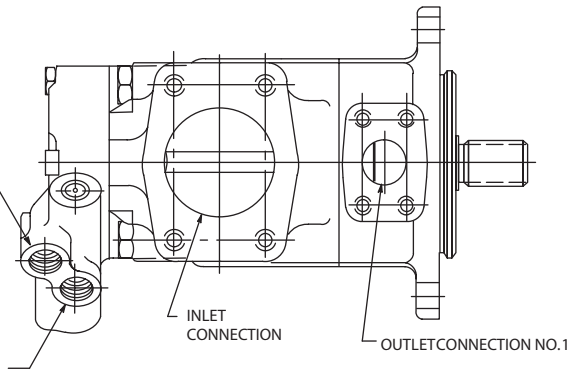

Note: For installation dimensions and performance data of basic pump series, refer to preceding pages.

Pumps with priority valve cover

Dimensions in millimeters (inches)

Model series	A	Dimensions B	C	D
2520VQP	276,6 (10.89)	113,0 (4.45)	101,6 (4.00)	38,1 (1.50)
3520VQP	300,7 (11.84)	124,5 (4.90)	114,3 (4.50)	38,1 (1.50)
4520VQP	331,0 (13.03)	144,8 (5.70)	119,4 (4.70)	42,9 (1.69)

SECONDARY OUTLET PORT
.875-14 UNF-2B THD PORT
MACHINED TO .62 TUBE SIZE
PER SAE SPEC FOR STRAIGHT
THD "O" RING BOSS.

#2 PRIMARY OUTLET PORT
.750-16 UNF-2B THD. PORT MACHINED
TO .50 TUBE SIZE PER SAE SPEC.
FOR STRAIGHT THREAD "O" RING BOSS

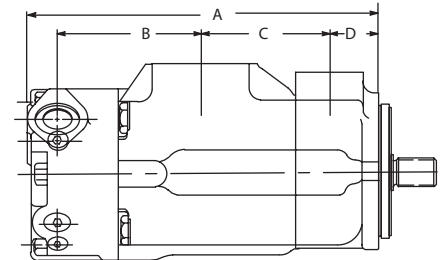
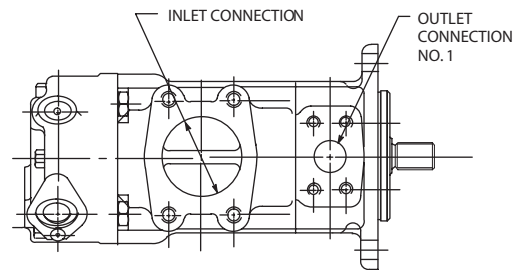
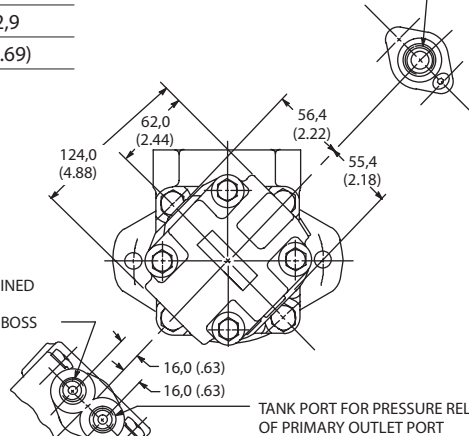

Optional Shafts

Splined Shafts

Dimensions in millimeters (inches)

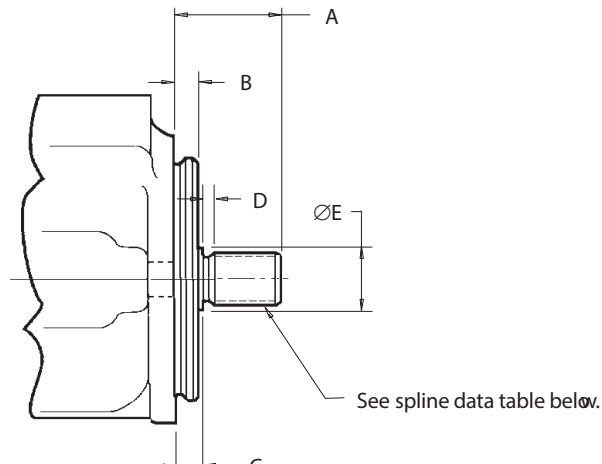

Pump	Shaft Code	A	B	C	D	ØE	Spline Data (See below w.)
2520VQ	11	44,5 (1.75)	9,53 (.375)	11,1 (.437)	4,1 (.16)	27,8 (1.09)	A
2520VQF,	123	44,5 (1.75)	9,53 (.375)	15,7 (.62)	4,1 (.16)	27,8 (1.09)	A
2520VQP	297	41,1 (1.62)	9,53 (.375)	7,9 (.31)	6,4 (.25)	27,8 (1.09)	C
3520VQ,							
3520VQF,	11	58,7 (2.31)	9,53 (.375)	11,1 (.437)	6,4 (.25)	35,1 (1.38)	D
3520VQP,	123	58,7 (2.31)	9,53 (.375)	15,2 (.60)	5,5 (.21)	35,1 (1.38)	D
3525VQ	297	55,5 (2.19)	12,7 (.500)	7,9 (.31)	5,5 (.21)	35,1 (1.38)	E
4520VQ,							
4520VQF,							
4520VQP,	11	61,9 (2.44)	12,7 (.500)	14,3 (.565)	9,7 (.38)	39,6 (1.56)	D
4525VQ,	130	61,9 (2.44)	12,7 (.500)	15,2 (.60)	9,9 (.39)	40,4 (1.59)	D
4535VQ	297	55,5 (2.19)	12,7 (.500)	7,9 (.31)	6,4 (.25)	39,6 (1.56)	E

Spline Data Table

(Involute splines from above chart)

Spline Data Reference	Number of Teeth	Pitch	Major Diameter	Form Diameter	Minor Diameter	Minor Diameter
A	13	16/32	22,17 (.873) 22,15 (.872)	19,03 (.749)	18,16 (.715)	Major dia. fit
C	13	16/32	21,8 (.858) 21,6 (.852)	19,03 (.749)	18,16 (.715)	Side fit
D	14	12/24	31,70 (1.248) 31,67 (1.247)	27,4 (1.08)	26,42 (1.040)	Major dia. fit
E	14	12/24	31,2 (1.229) 31,1 (1.223)	27,4 (1.08)	26,42 (1.040)	Side fit

Optional Shafts

Straight Key Shafts

Dimensions in millimeters (inches)

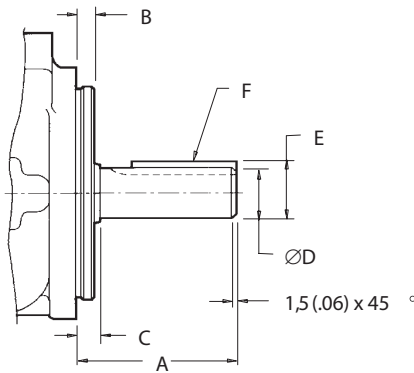

Pump	Shaft Code	A	B	C	ØD	E	F key width x length
2520VQ,	1	58,7 (2.31)	9,53 (.375)	11,1 (.435)	22,23 (.875) 22,20 (.874)	24,5 (.966) 24,4 (.961)	4,75 (.187) x 32 (1.25)
2520VQF,	86	77,7 (3.06)	9,53 (.375)	11,1 (.435)	25,37 (.999) 25,35 (.998)	28,3 (1.11) 28,1 (1.10)	6,35 (.250) x 50,8 (2.00)
2520VQP	203	77,7 (3.06)	9,53 (.375)	7,9 (.31) ▲	25,40 (1.00) 25,35 (.998)	28,20 (1.11) 27,94 (1.10)	6,35 (.250) x 49,2 (1.938)
3520VQ,	1	73,2 (2.88)	9,53 (.375)	11,1 (.435)	31,75 (1.250) 31,70 (1.248)	35,36 (1.39) 34,10 (1.38)	7,94 (.313) x 38,1 (1.50)
3520VQF, 3520VQP,	86	85,9(3.38)	9,53 (.375)	11,1 (.435)	34,90 (1.374) 34,87 (1.373)	38,6 (1.52) 38,3 (1.51)	7,92 (.312) x 54 (2.13)
3525VQ	203	84,1 (3.31)	12,7 (.500)	7,9 (.31) ▲	34,90 (1.374) 34,87 (1.373)	38,6 (1.52) 38,3 (1.51)	7,92 (.312) x 54 (2.125)
4520VQ, 4520VQF,	1	62,0 (2.44)	12,7 (.500)	14,22 (.560)	31,75 (1.250) 31,70 (1.248)	35,36 (1.39) 34,10 (1.38)	7,92 (.312) x 28,5 (1.12)
4520VQP, 4525VQ,	86	87,4 (3.44)	12,7 (.500)	14,22 (.560)	38,07 (1.499) 38,05 (1.498)	42,4 (1.67) 42,1 (1.66)	9,53 (.375) x 50,8 (2.00)
4535VQ	203	90,4 (3.56)	12,7 (.500)	7,9 (.31) ▲	38,07 (1.499) 38,05 (1.498)	42,4 (1.67) 42,1 (1.66)	9,53 (.375) x 57,1 (2.25)

▲ Shaft shoulder inside recess in pilot.

Typical Performance

Shaft End Pumps

2520VQ Double Pumps & 2520VQV10 Triple Pumps

Performance Constants:

SAE 10W fluid @ 82 °C (180 °F)

Pump inlet @ 0 psig (14.7 psia)

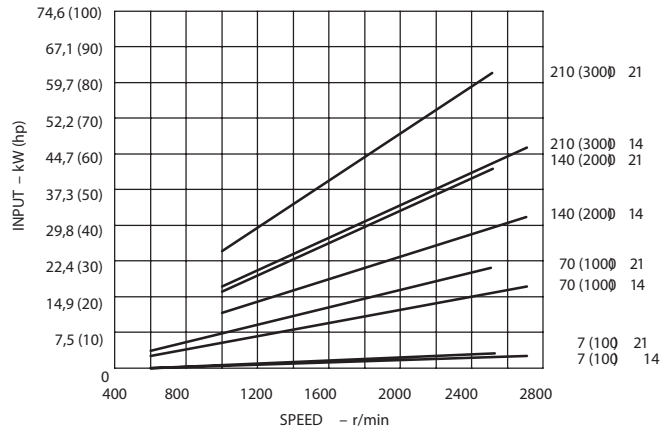
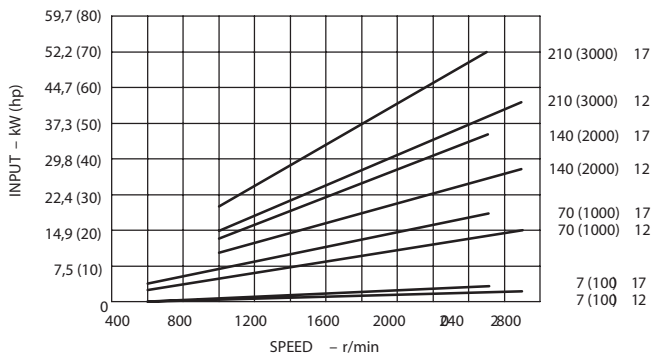
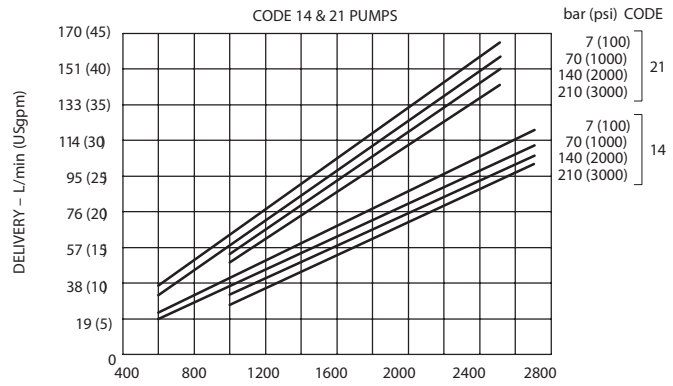
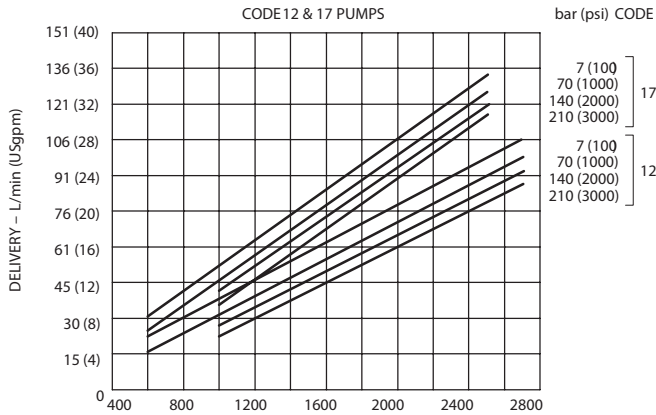

Typical Performance

Shaft End Pumps

3520VQ & 3525VQ Double Pumps, 352*VQV10 Triple Pumps,
3525VQT Double Thru-drive Pumps

Performance Constants:

SAE 10W fluid @ 82 °C (180 °F)

Pump inlet @ 0 psig (14.7 psia)

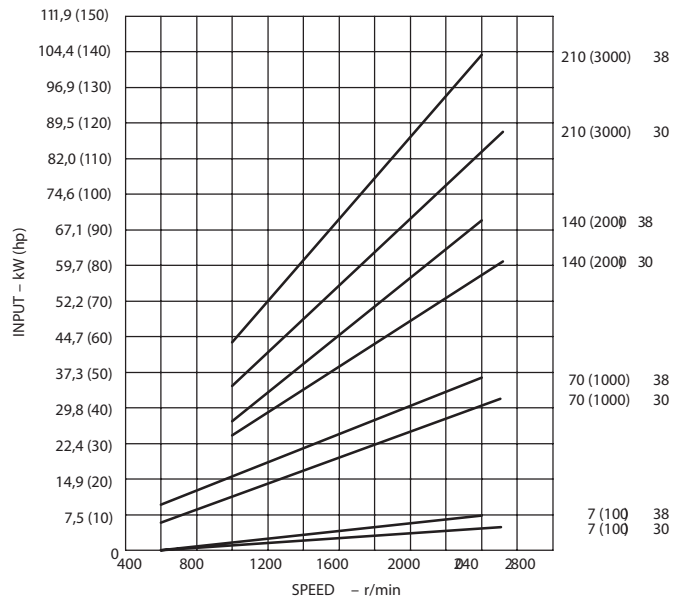
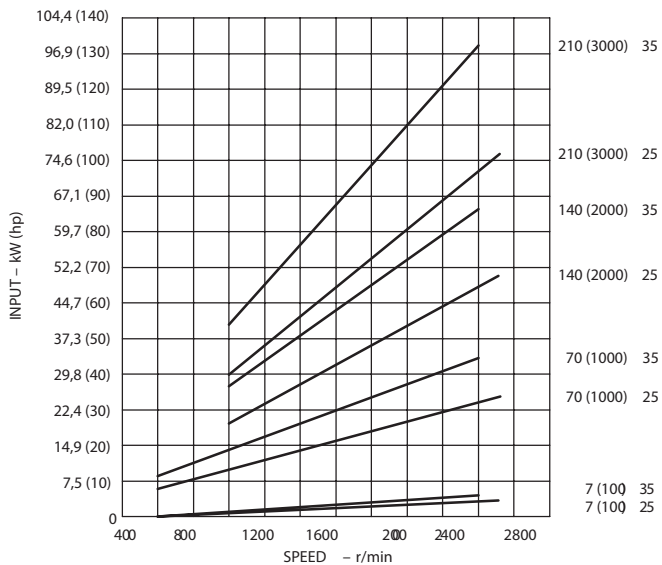
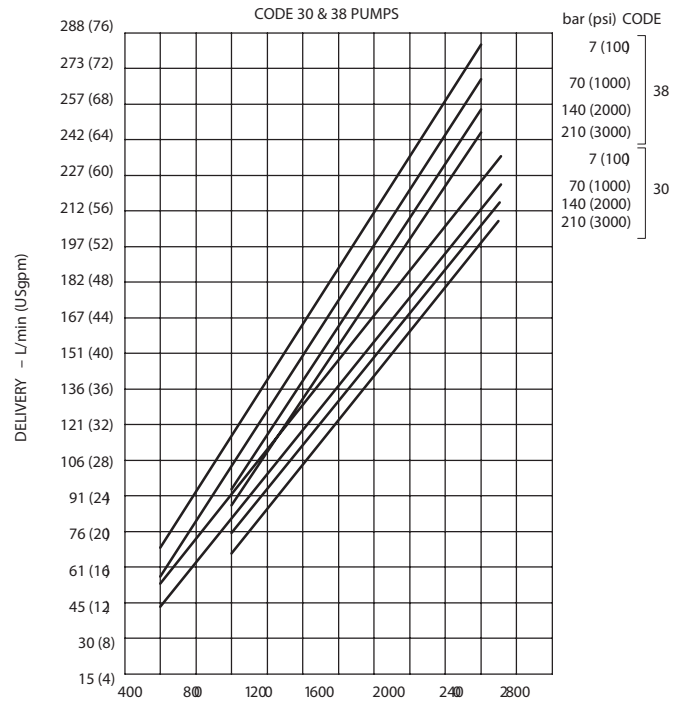
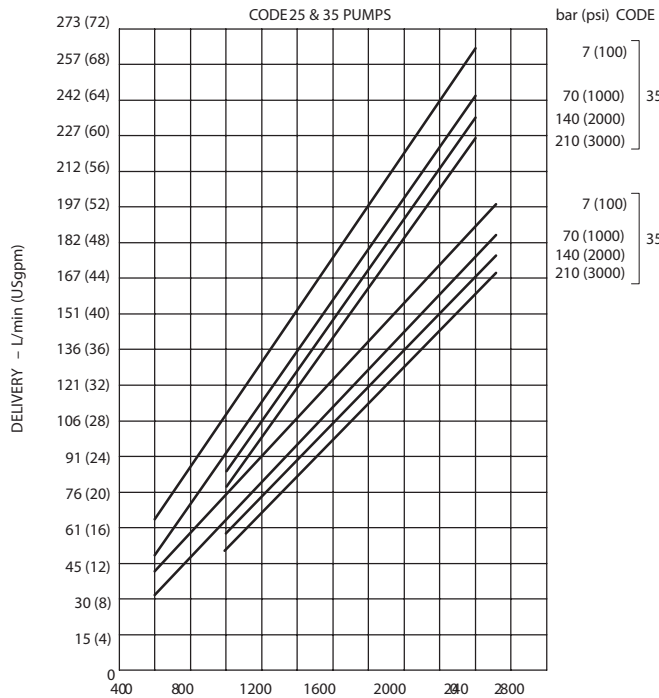

Shaft End Pumps 4520VQ, 4525VQ & 4535VQ Double Pumps,
45*5VQV10 Triple Pumps, 4525VQT Double Thru-drive Pumps

Performance Constants:
SAE 10W fluid @ 82 °C (180 °F)
Pump inlet @ 0 psig (14.7 psia)

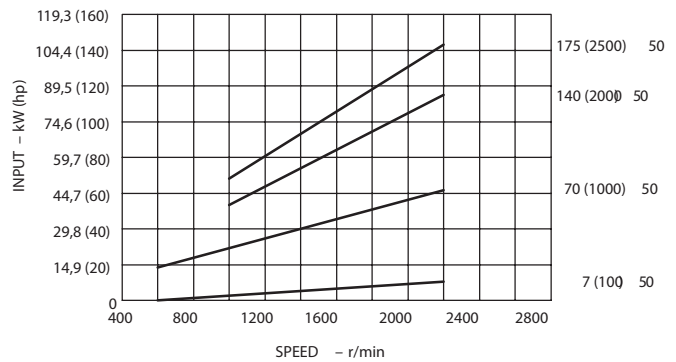
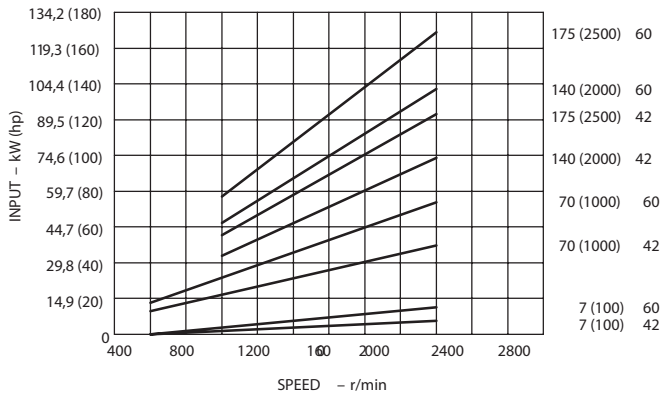
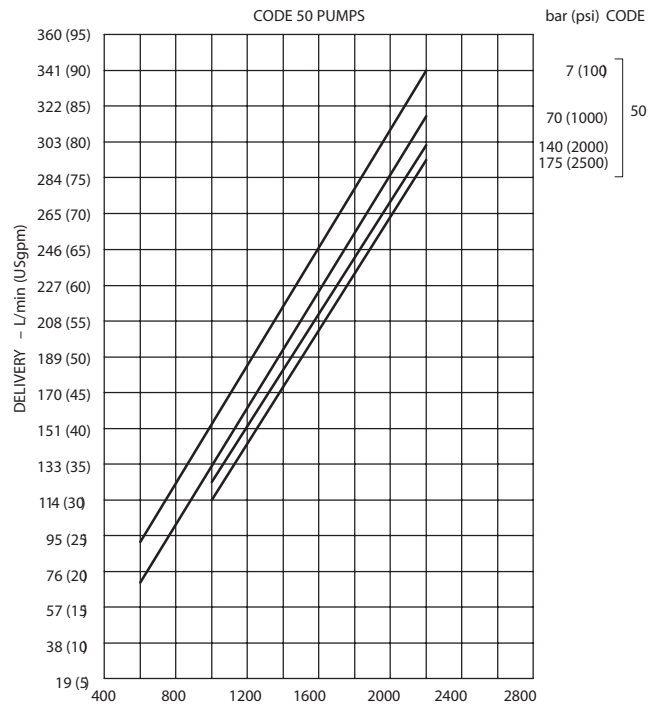
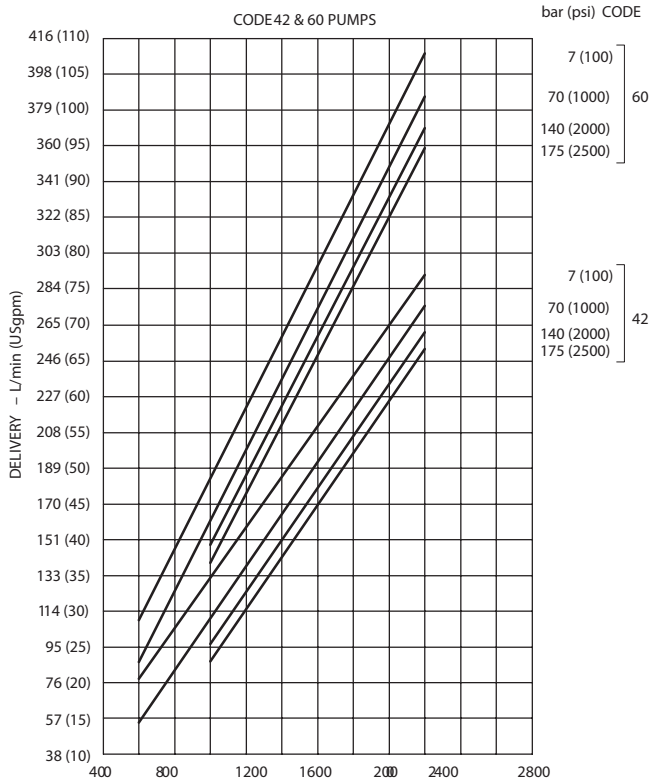

Typical Performance

Cover-end Pumps of 2520VQ Double Pumps & Center Pumps of 2520VQV10 Triple Pumps

Performance Constants:
 SAE 10W fluid @ 82 °C (180 °F)
 Pump inlet @ 0 psig (14.7 psia)

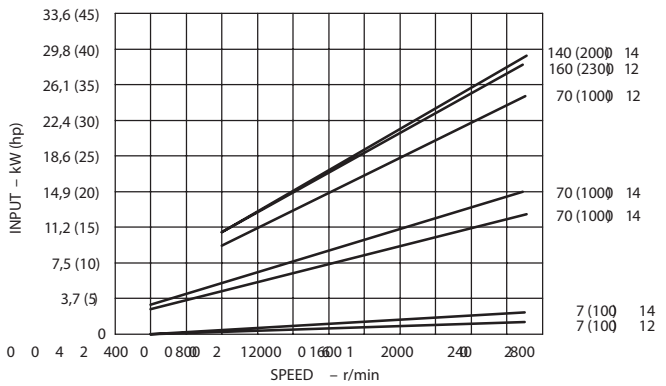
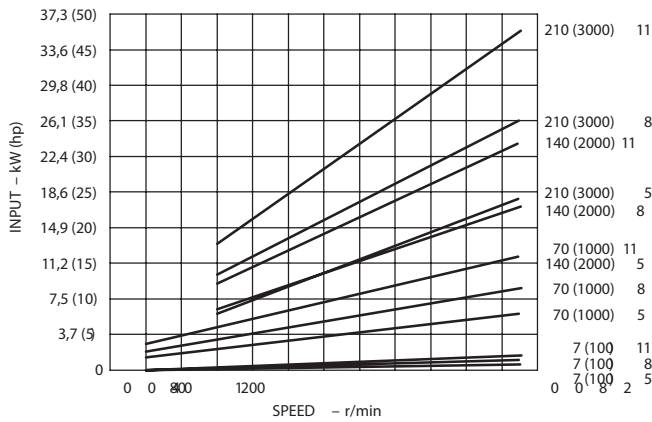
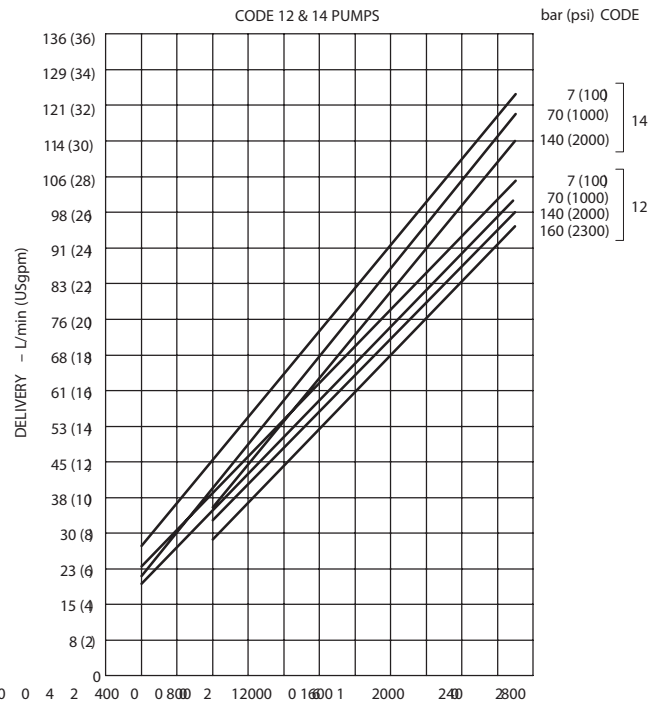
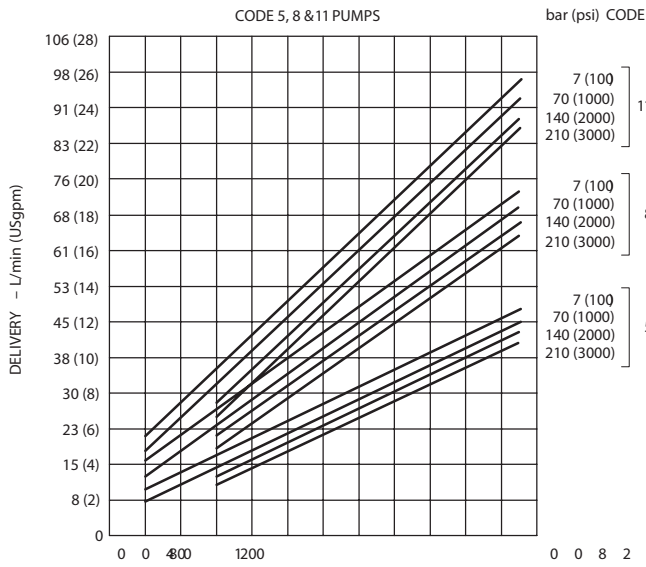

Cover-end Pumps of 3520VQ Double Pumps, Center Pumps of 3520VQV10 Triple Pumps, Rear Pumps of 3525VQT Double Thru-drive Pumps

Performance Constants:
 SAE 10W fluid @ 82 °C (180 °F)
 Pump inlet @ 0 psig (14.7 psia)

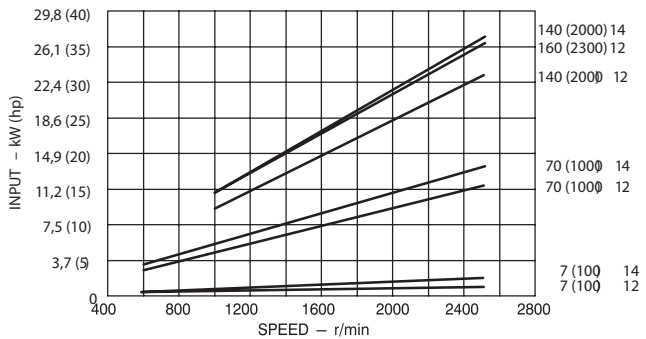
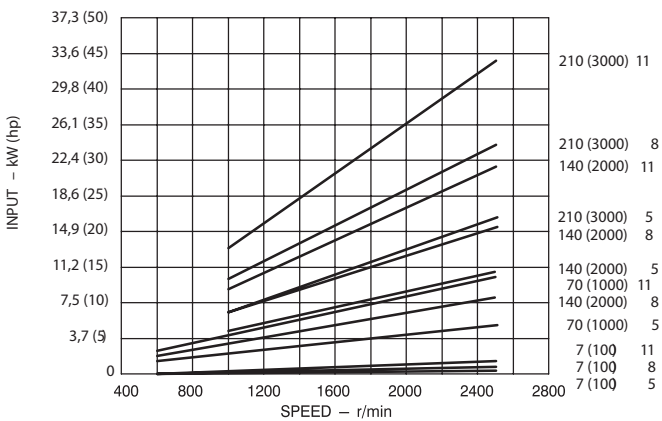
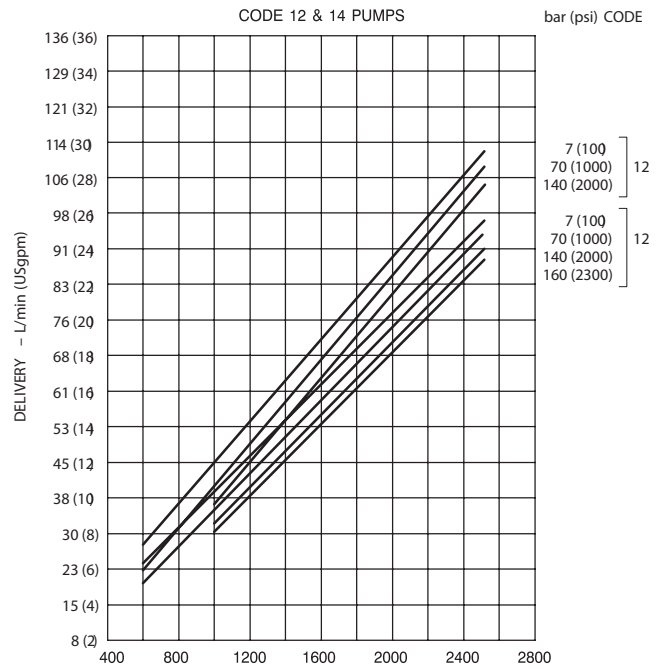
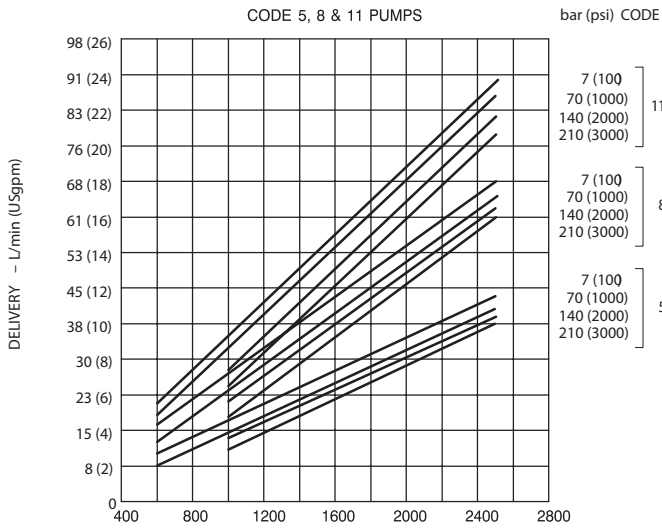

Typical Performance

Cover-end Pumps of 3525VQ Double Pumps & Center Pumps of 3525VQV10 Triple Pumps

Performance Constants:
 SAE 10W fluid @ 82 °C (180 °F)
 Pump inlet @ 0 psig (14.7 psia)

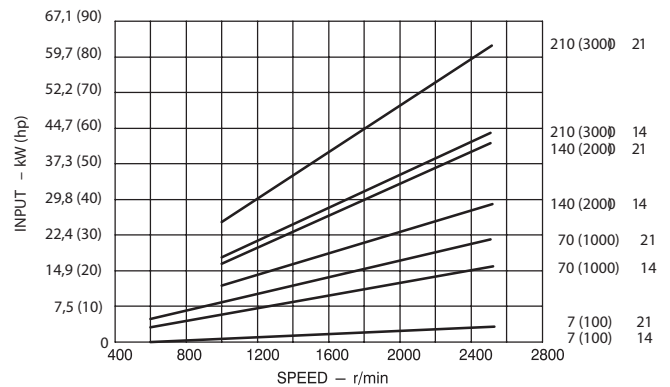
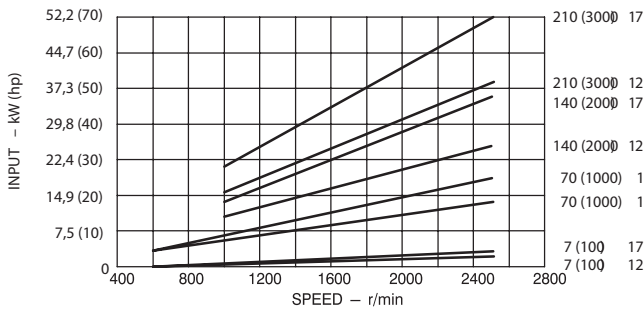
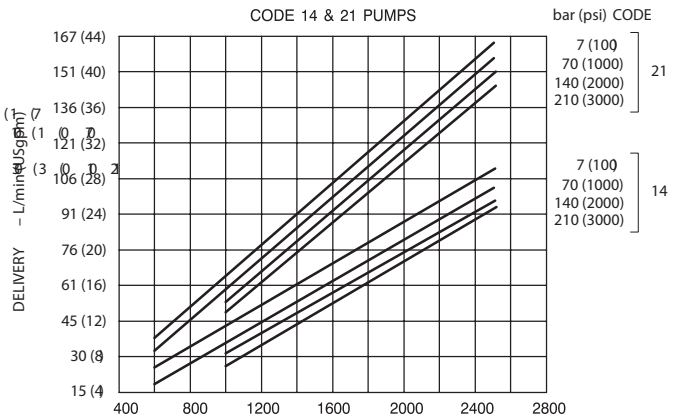
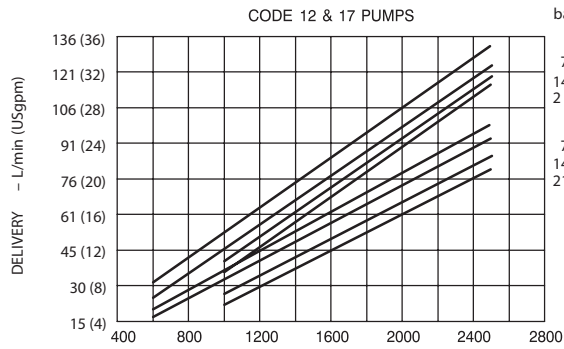

Cover-end Pumps of 4520VQ Double Pumps & Center Pumps of 4520VQV10 Triple Pumps

Performance Constants:
 SAE 10W fluid @ 82 °C (180 °F)
 Pump inlet @ 0 psig (14.7 psia)

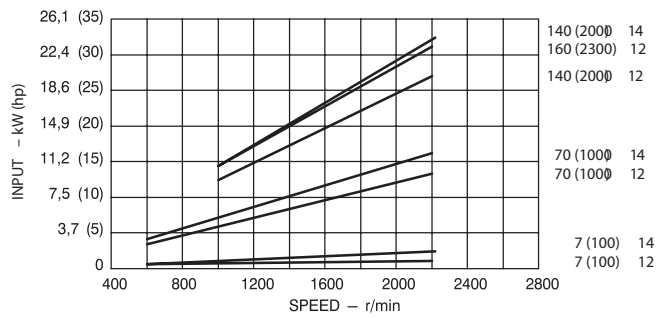
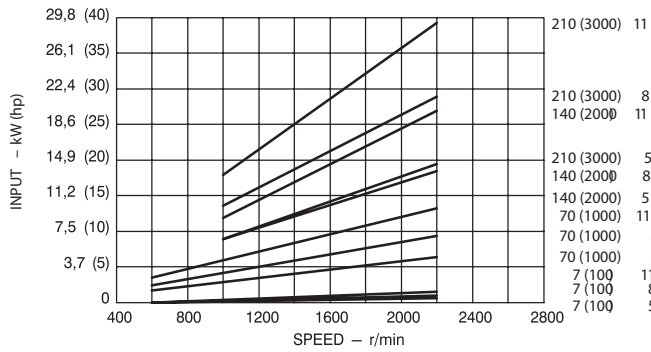
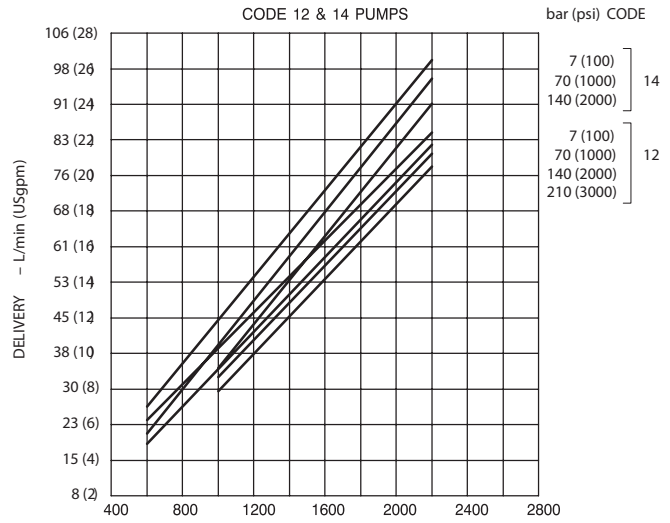
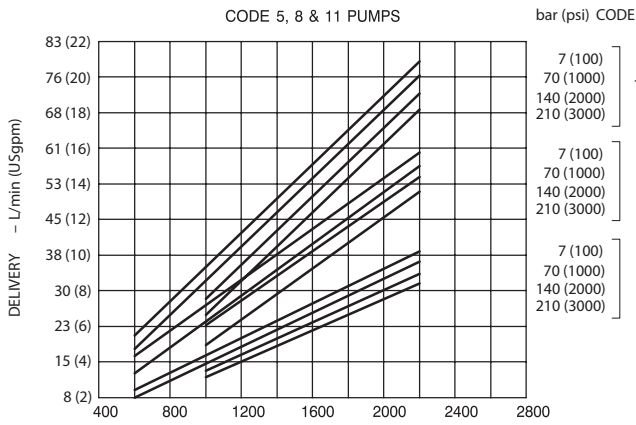

Typical Performance

Cover-end Pumps of 4520VQ Double Pumps, Center Pumps of 4525VQV10 Triple Pumps, Rear Pumps of 4525VQT Double Thru-drive Pumps

Performance Constants:
 SAE 10W fluid @ 82 °C (180 °F)
 Pump inlet @ 0 psig (14.7 psia)

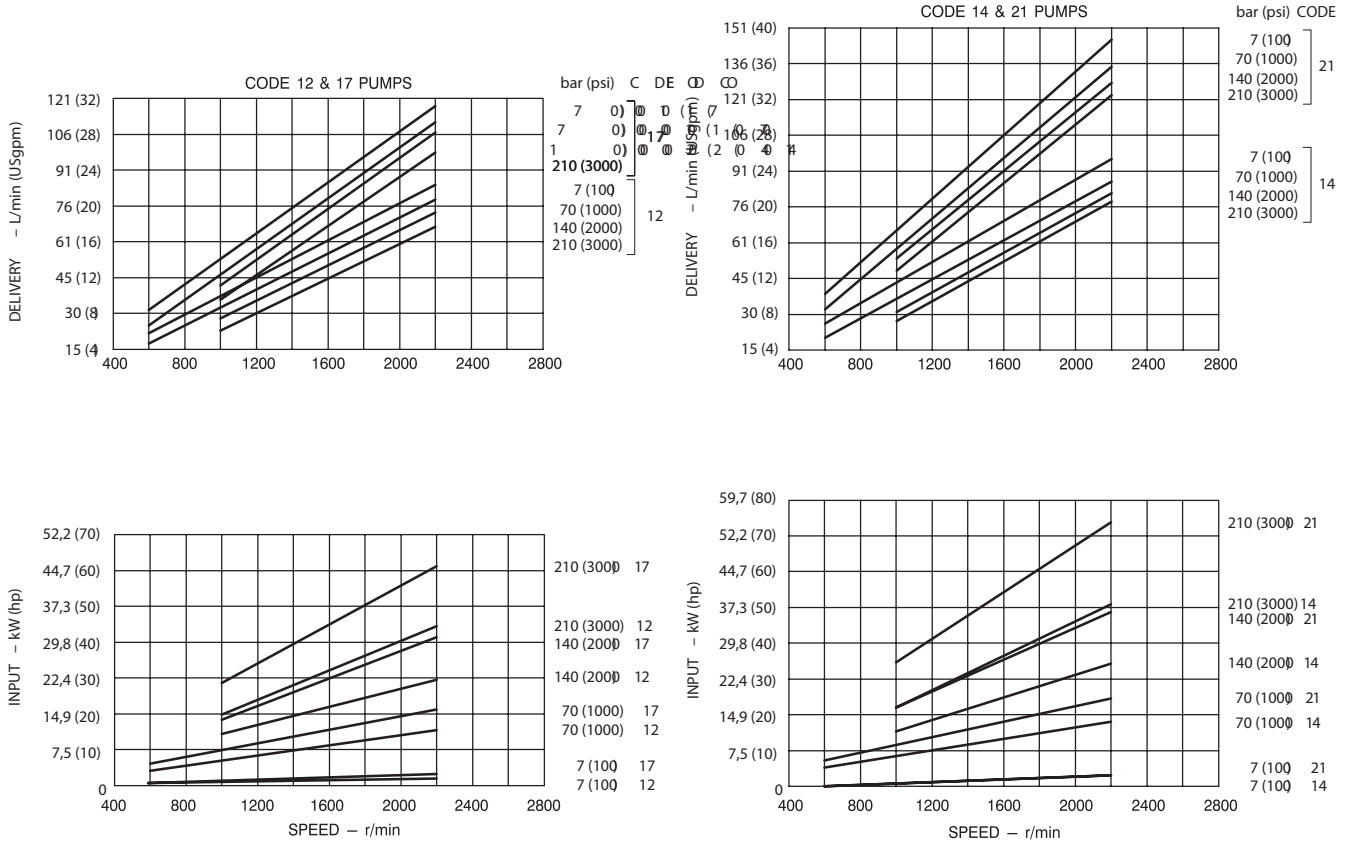

Cover-end Pumps of 4535VQ Double Pumps & Center Pumps of 4535VQV10 Triple Pumps

Performance Constants:
 SAE 10W fluid @ 82 °C (180 °F)
 Pump inlet @ 0 psig (14.7 psia)

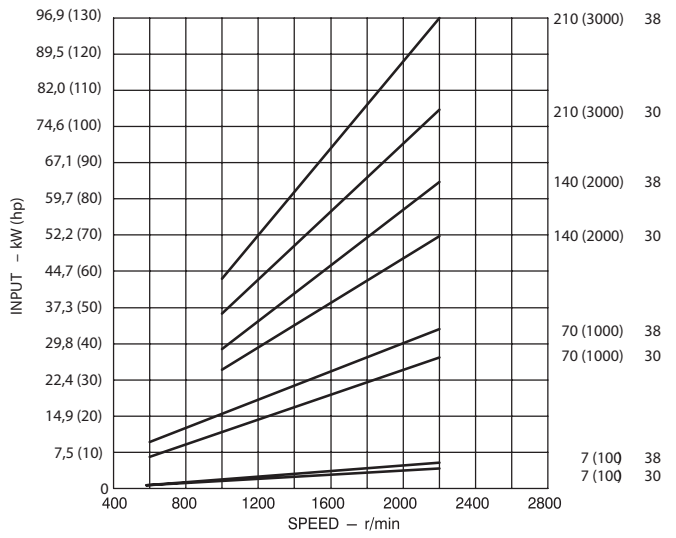
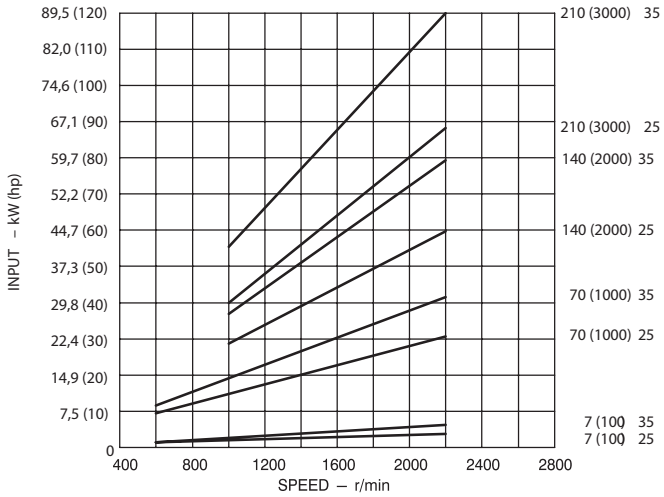
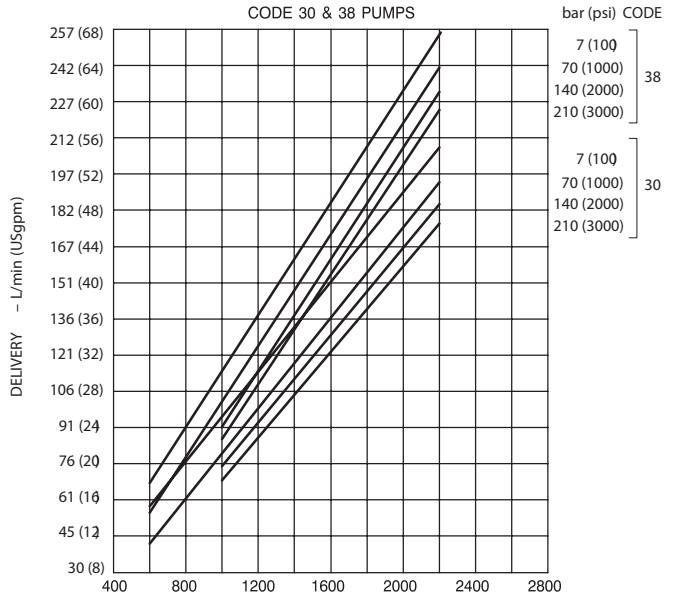
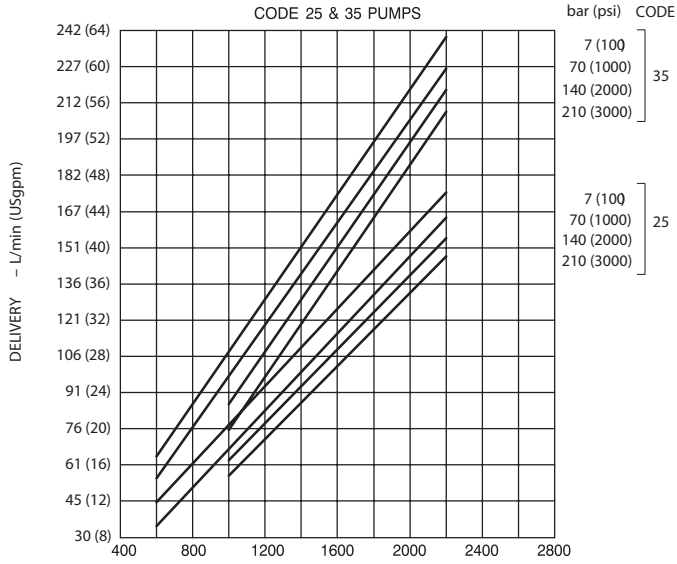

Typical Performance

Controlled Flow - Integral Valves (cover end) Models 2520VQF, 3520VQF & 4520VQF Double Pumps

Performance Constants:
 SAE 10W fluid @ 82 °C (180 °F)
 Pump inlet @ 0 psig (14.7 psia)

Curves shown for 70 bar (1000 psi) operating pressure. Controlled flow varies slightly at other pressures.

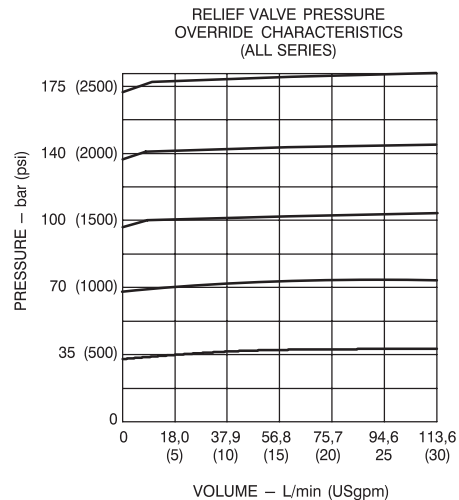
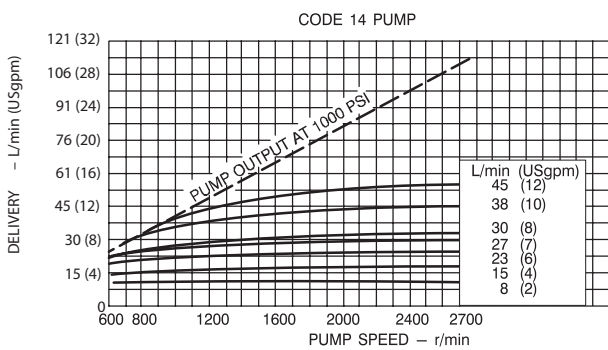
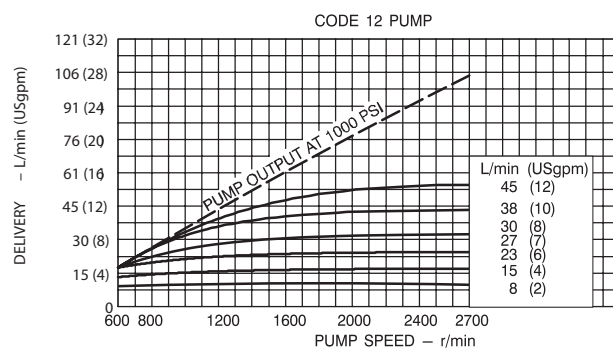
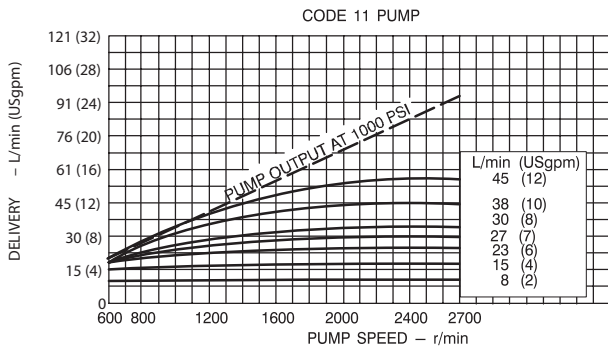
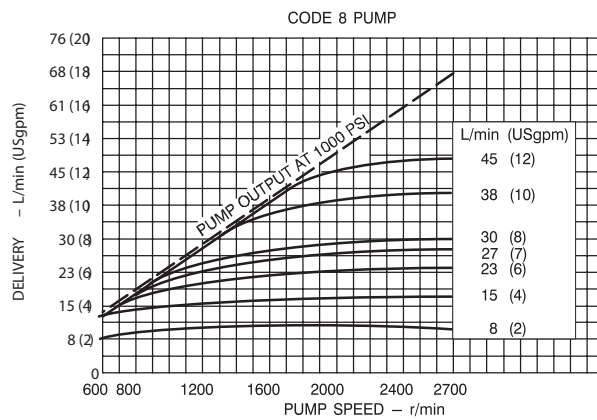
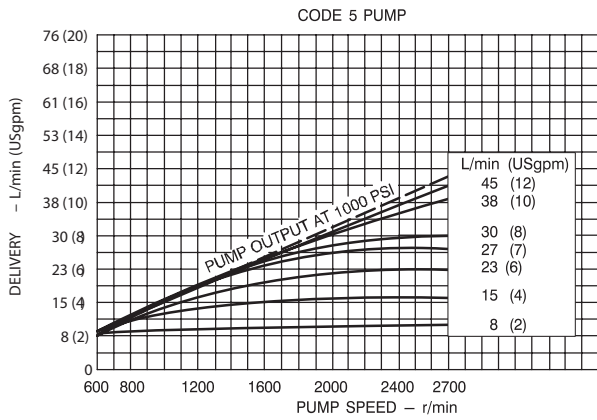

Speed Correction Curves

Maximum operating speed correction factors based on pump inlet conditions.

2520VQ Series

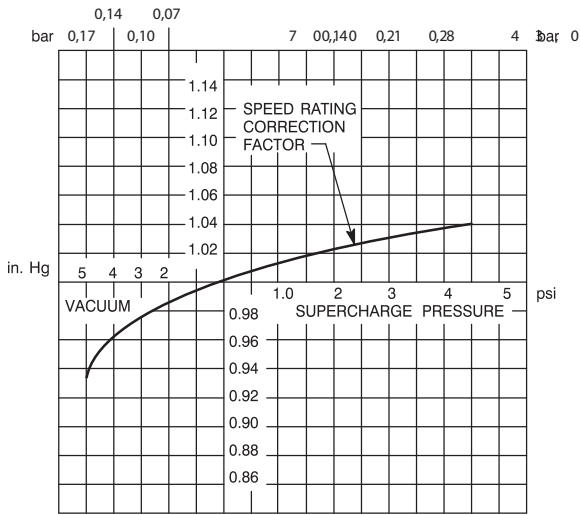

Maximum operating speeds shown on performance curves are for pumps operating at 0 psi inlet condition. To compute maximum operating speeds at other inlet conditions use the appropriate speed rating correction factor shown in the curve above.

EXAMPLE: Max. Speed @ 0 psi Inlet 2700 r/min
 Correction Factor @ 5 in. Hg $\times \frac{.93}{1.0}$
 Max. Speed @ 5 in. Hg Inlet 2511 r/min

Pump inlet suction should not exceed 5 in. Hg vacuum. Positive pressure on inlet should not exceed 1.4 bar (20 psi).

4520VQ & 4535VQ Series

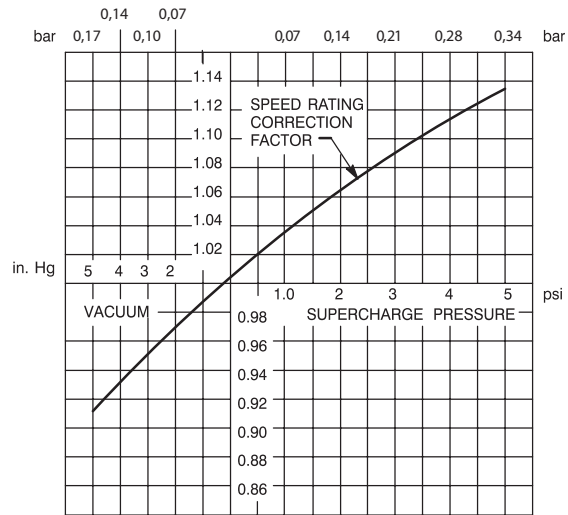

Maximum operating speeds shown on performance curves are for pumps operating at 0 psi inlet condition. To compute maximum operating speeds at other inlet conditions use the appropriate speed rating correction factor shown in the curve above.

EXAMPLE: Max. Speed @ 0 psi Inlet 2200 r/min
 Correction Factor @ 5 in. Hg $\times \frac{.91}{1.0}$
 Max. Speed @ 5 in. Hg Inlet 2002 r/min

Pump inlet suction should not exceed 5 in. Hg vacuum. Positive pressure on inlet should not exceed 1.4 bar (20 psi).

3520VQ & 3525VQ Series

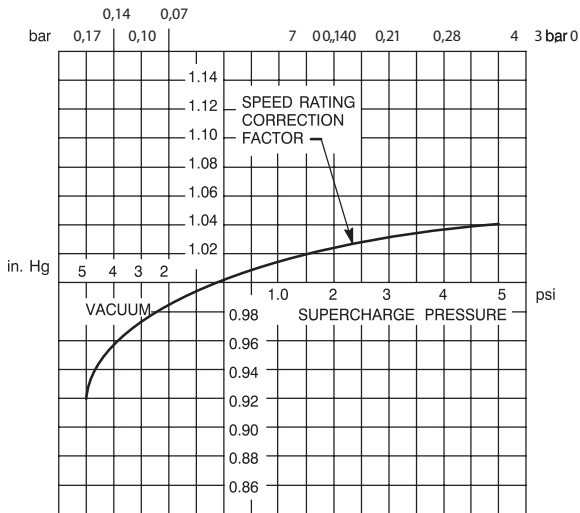

Maximum operating speeds shown on performance curves are for pumps operating at 0 psi inlet condition. To compute maximum operating speeds at other inlet conditions use the appropriate speed rating correction factor shown in the curve above.

EXAMPLE: Max. Speed @ 0 psi Inlet 2500 r/min
 Correction Factor @ 5 in. Hg $\times \frac{.92}{1.0}$
 Max. Speed @ 5 in. Hg Inlet 2300 r/min

Pump inlet suction should not exceed 5 in. Hg vacuum. Positive pressure on inlet should not exceed 1.4 bar (20 psi).

Triple Pump Operating Specifications

Maximum speed ratings for triple pumps are dependent upon V10 ring size. See chart below for ratings.

Pressure ratings are shown on page 25 for VQ sections and page 69 for V10 sections.

Cover-end pump (V10)
delivery/USgpm
@ 1200 rpm and 100 psi

Maximum Speed - r/min

	2520VQSV10	3520VQSV10	3525VQSV10	4525VQSV10	4535VQSV10
1	2700	2500	2500	2200	2200
2	2700	2500	2500	2200	2200
3	2700	2500	2500	2200	2200
4	2700	2500	2200* 2500+	2200	2200
5	2700	2500	2200* 2500+	2200	2200
6	2200* 2500+	2200* 2500+	2200* 2400+	2200	2200
7	1900* 2200+	1900* 2200+	2200	2000* 2200+	2100* 2200+

* With V10 pressure over 70 bar (1000 psi)

+ With V10 pressure to 70 bar (1000 psi)

Typical Performance

For triple pump performance, use curves listed in this table:

Triple pump model series	Shaft end pump	Center pump	Cover end pump	Page no.
2520VQSV10	25**VQ			34
		**20VQ		37
			V10	75, 78, 79
3520VQSV10	35**VQ			35
		**20VQ		38
			V10	75, 78, 79
3525VQSV10	35**VQ			35
		**25VQ		39
			V10	75, 78, 79
4525VQSV10	45**VQ			36
		**25VQ		41
			V10	75, 78, 79
4535VQSV10	45**VQ			36
		**35VQ		42
			V10	75, 78, 79

Model Codes

Triple Pump

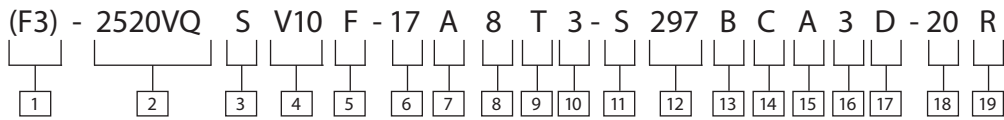

1 F3 - Viton seals
Omit if not required.

2 Double pump series
First two numerals in the series denote shaft end of triple pump; second two numerals denote the center pump.
2520VQ 4525VQ
3520VQ 4535VQ
3525VQ

3 SAE mounting
S – SAE mounting per J 744

4 Single pump series
Cover end pump of triple pump

5 Cover options for V10 pump
S – Standard cover
F – Integral flow control & relief valve
P – Integral priority valve & relief

6 SAE rated flow, shaft-end pump
Refer to table 1.

7 Double pump port connections
A – All SAE 4-bolt flange
AM – Metric 4-bolt flange

8 SAE rated flow, center pump
Refer to table 1.

9 No. 3 outlet port connection
Standard Cover
S – .750-16 straight thread
Flow Control Cover
T – .750-16 straight thread, control port & tank port.
Priority Valve Cover
K – .5625-18 straight thread, primary port & tank port.
.750-16 straight thread, secondary port

10 SAE rated flow, cover end pump
Refer to table 1.

11 Shaft seal
S – Double seal
Blank – Single seal

12 Splined shaft
297 – All series

13 No. 1 outlet port position
Refer to table 2.

14 No. 2 outlet port position
Refer to table 2.

15 No. 3 outlet port position
Refer to table 2.

16 Controlled flow rate, V10F & V10P
Omit for standard cover.
3 – 11 L/min (3 USgpm)
4 – 15 L/min (4 USgpm)

5 – 19 L/min (5 USgpm)
6 – 23 L/min (6 USgpm)
7 – 27 L/min (7 USgpm)
8 – 30 L/min (8 USgpm)

17 Relief valve setting, V10F & V10P
Omit for standard cover.

A – 17 bar (250 psi) F – 100 bar (1500 psi)
B – 35 bar (500 psi) G – 121 bar (1750 psi)
C – 52 bar (750 psi) H – 140 bar (2000 psi)
D – 70 bar (1000 psi) J – 155 bar (2250 psi)
E – 86 bar (1250 psi) K – 175 bar (2500 psi)

18 Design
Subject to change. Installation dimensions remain the same for designs -20 through -29.

19 Shaft rotation
(Viewed from shaft end of pump)
L – Left hand (counterclockwise)
R – Right hand

Table 1

Rated Flow @ 1200 r/min & 100 psi – USgpm

Shaft-end pump 2520	Shaft-end pump 35**	Shaft-end pump 45**	Center pump **20	Center pump **25	Center pump **35	Cover-end pump V10
12	25	42	5	12	25	1
14	30	50	8	14	30	2
17	35	60	11	17	35	3
21	38		12	21	38	4
			14			5
						6
						7

Table 2

Outlet position code

Position viewed from cover end	13 No. 1 outlet	14 No. 2 outlet	15 No. 3 outlet
Opposite inlet	A	A (4535 only)	A
135° CCW from inlet	–	A	–
90° CCW from inlet	B	B (4535 only)	B
45° CCW from inlet	–	B	–
Inline with inlet	C	C (4535 only)	C
45° CW from inlet	–	C	–
90° CW from inlet	D	D (4535 only)	D
135° CW from inlet	–	D	–

Installation Dimensions

Triple Pumps

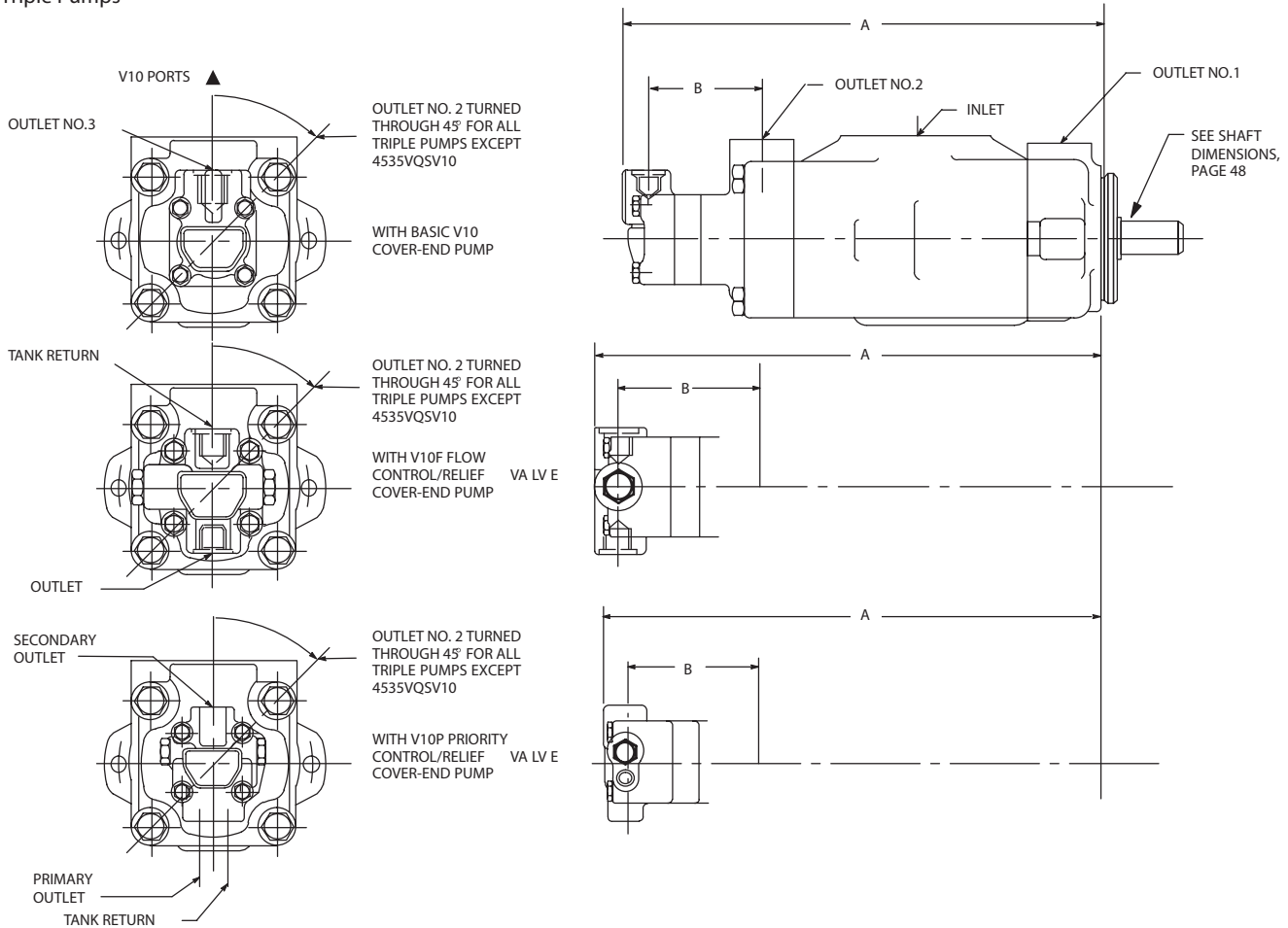

V10 cover can be assembled in any of four positions; see model codes, page 46. 4535VQSV10 shown.

Model series	Dimensions mm (in.)					
	1, 2 & 3 USgpm*		4 & 5 USgpm*		6 & 7 USgpm*	
	A	B	A	B	A	B
2520VQSV10	350 (13.78)	87 (3.43)	356 (14.03)	94 (3.68)	361 (14.23)	99 (3.88)
2520VQSV10F	363 (14.30)	105 (4.12)	370 (14.55)	111 (4.38)	375 (14.75)	116 (4.58)
2520VQSV10P	364 (14.35)	105 (4.12)	371 (14.60)	111 (4.38)	376 (14.80)	116 (4.58)
3520VQSV10	372 (14.66)	87 (3.43)	379 (14.91)	94 (3.68)	384 (15.11)	99 (3.88)
3520VQSV10F	386 (15.18)	105 (4.12)	392 (15.43)	111 (4.37)	397 (15.63)	116 (4.57)
3520VQSV10P	387 (15.23)	105 (4.12)	393 (15.48)	111 (4.37)	398 (15.68)	116 (4.57)
3525VQSV10	381 (15.00)	86 (3.40)	387 (15.25)	93 (3.65)	392 (15.45)	98 (3.85)
3525VQSV10F	394 (15.52)	104 (4.09)	401 (15.77)	110 (4.34)	406 (15.97)	115 (4.54)
3525VQSV10P	395 (15.57)	104 (4.09)	402 (15.82)	110 (4.34)	407 (16.02)	115 (4.54)
4525VQSV10	420 (16.53)	86 (3.40)	426 (16.78)	93 (3.65)	431 (16.98)	98 (3.85)
4525VQSV10F	433 (17.05)	104 (4.09)	439 (17.30)	110 (4.34)	445 (17.50)	115 (4.54)
4525VQSV10P	434 (17.10)	104 (4.09)	441 (17.35)	110 (4.34)	446 (17.55)	115 (4.54)
4535VQSV10	445 (17.50)	84 (3.31)	451 (17.75)	90 (3.56)	456 (17.95)	96 (3.76)
4535VQSV10F	458 (18.02)	102 (4.00)	464 (18.27)	108 (4.25)	469 (18.47)	113 (4.45)
4535VQSV10P	459 (18.07)	102 (4.00)	465 (18.32)	108 (4.25)	470 (18.52)	113 (4.45)

* SAE rated flows (@1200 rpm and 100 psi) of V10, V10F & V10P cover-end pump (see page 69).

For detailed dimensions of double pump end, see pages 28 through 30; for V10 series cover-end pump, see pages 71 and 72.

Shaft – Triple Pumps

Dimensions – No. 297 shaft

Dimensions in millimeters (inches)

Model	A	B	C
2520VQSV10	41,1 (1.62)	7,9 (.31)	27,7 (1.09)
352*VQSV10	55,4 (2.18)	7,9 (.31)	35,1 (1.38)
45**VQSV10	55,4 (2.18)	7,9 (.31)	40,4 (1.59)

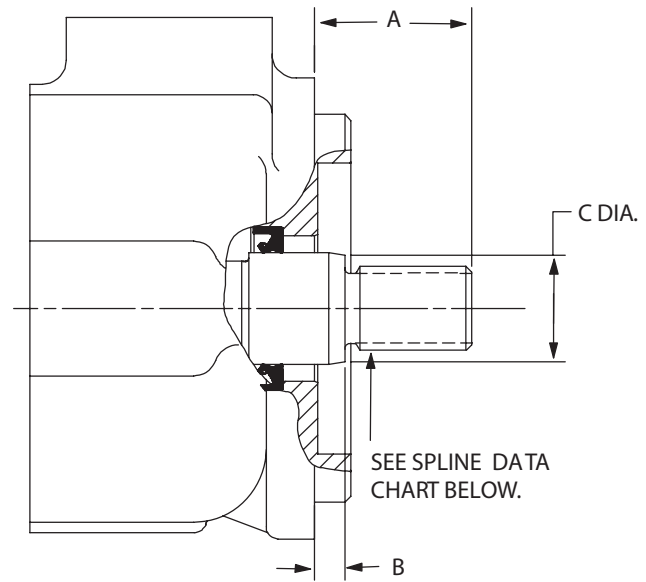

Spline data – No. 297 shaft

Dimensions in millimeters (inches)

Model	No. of teeth	Pitch	Major dia.	Form dia.	Minor dia.	Fit
2520VQSV10	13	16/32	21,8 (.858) 21,6 (.852)	19,0 (.749)	18,16 (.715)	
352*VQSV10	14	12/24	31,2 (1.229) 31,1 (1.223)	27,4 (1.08)	26,4 (1.040)	Side fit
45**VQSV10	14	12/24	31,2 (1.229) 31,1 (1.223)	27,4 (1.08)	26,4 (1.040)	

Shaft torque ratings – No. 297 shaft

Pump series	Drive shaft	Max. torque capability Nm (lb-in)
	Designation	
2520VQSV10	"B" per SAE J744C. 22-4 per SAE J744 Oct '83	344 (3040)
352*VQSV10	"C" per SAE J744C. 32-4 per SAE J744 Oct '83	791 (7000)
45**VQSV10	"C" per SAE J744C. 32-4 per SAE J744 Oct '83	1017 (9000)

Single Thru-drive Pump Operating Specifications

Model Series	Delivery USgpm @ 1200 r/min (10.0 psi)	Displ. cm ³ /r (in ³ /r)	Max. r/min	Max. bar (psi)	Typical del. L/min (USgpm) @ max. speed & pressure	Typical input kW (hp) @ max. speed & pressure	Approx. Wt. kg (lb.)
25VQT*S	12	40,2 (2.45)	2700	210 (3000)	88,5 (23)	41,0 (55)	19,5 (43)
	14	45,4 (2.77)	2700	210 (3000)	103,8 (27)	46,6 (62.5)	
	17	55,2 (3.37)	2500	210 (3000)	119,2 (31)	51,8 (69.5)	
	21	67,5 (4.12)	2500	210 (3000)	146,2 (38)	61,9 (83)	
35VQT*S	25	81,6 (4.98)	2500	210 (3000)	173,1 (45)	75,3 (101)	28,6 (63)
	30	97,7 (5.96)	2500	210 (3000)	211,5 (55)	87,7 (117.5)	
	35	112,8 (6.88)	2400	210 (3000)	230,8 (60)	98,5 (132)	
	38	121,6 (7.42)	2400	210 (3000)	250,0 (65)	104,4 (140)	
45VQT*S	42	138,7 (8.46)	2200	175 (2500)	255,8 (66.5)	91,4 (122.5)	38,2 (84)
	50	162,3 (9.90)	2200	175 (2500)	303,8 (79)	105,2 (141)	
	60	193,4 (11.80)	2200	175 (2500)	369,2 (96)	126,8 (170)	

Performance constants SAE 10W fluid @ 82 C. (180 F.)
Pump inlet @ 0 PSIG (14.7 PSIA)

Note: Outlet pressure must always be higher than inlet pressure. See page 7 for details.

Typical Performance

For thru-drive performance, use curves on the following pages:

Thru-drive model series	Page no.
25VQT*S	22
35VQT*S	23
45VQT*S	24

Model Codes

Thru-drive Single Pump

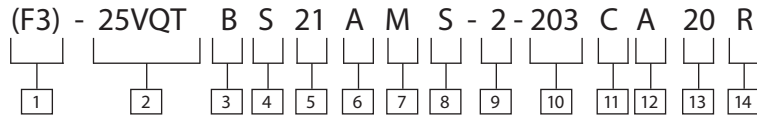

1 F3 - Viton seals
Omit if not required.

2 Intravane pump series – Thru-drive
25VQT
35VQT Standard bearing
45VQT

26VQT
36VQT Heavy duty bearing

3 Thru-drive connection mounting adapter (2-bolt)

Code	SAE Designation	
	J744C	J744 Oct '83
A	A	82-2
B	B	101-2
BP	Special mounting with spacer for Danfoss PVE12/19/21	
C	C	127-2 (not available on 25VQT)

4 Front mounting flange

Model series	SAE Designation	
	J744C	J744 Oct '83
2*VQT	B	101-2
3*VQT	C	127-2
45VQT	C	127-2

5 Geometric displacement
Code = SAE rating USgpm at 1200 r/min

Series	Code	cm ³ /r	(in ³ /r)
2*VQT	12	40,2	(2.45)
	14	45,4	(2.77)
	17	55,2	(3.37)
3*VQT	21	67,5	(4.12)
	25	81,6	(4.98)
	30	97,7	(5.96)
45VQT	35	112,8	(6.88)
	38	121,6	(7.42)
	42	138,7	(8.46)
	50	162,3	(9.90)
	60	193,4	(11.80)

6 SAE Port connections
4-bolt flange port connection

7 Metric threads on port connections
(Omit for inch threads)

8 Double shaft seal
S – Double shaft seal
Blank – Single seal

9 Coupling for tandem pump
2 – SAE splined coupling included with pump

10 Shaft type
203 – Heavy duty straight key
297 – Splined

11 Outlet positions
(Viewed from cover end of pump)
A – Opposite inlet
B – 90° CCW from inlet
C – In line with inlet
D – 90° CW from inlet

12 Adapter mounting orientation
(Viewed from cover end of pump)

Code	"A" adapter	"B" adapter
	J744C	J744 Oct '83
A	Rotated 45° CW with respect to pump mtg. flg.	In line with pump mtg. flg.
B	Rotated 45° CCW with respect to pump mtg. flg.	Rotated 90° with respect to pump mtg. flg.

13 Design
Subject to change. Installation dimensions remain the same for designs -20 through -29.

14 Shaft rotation
(Viewed from shaft end of pump)
L – Left hand (counterclockwise)
R – Right hand (clockwise)

NOTE:

For options other than listed above, i.e. shafts, ports, displacements and mountings, contact your Danfoss representative.

Installation Dimensions

25VQT*S Series

Dimensions in millimeters (inches)

Shaft options are shown on page 58.

See page 121 for selection of SAE 4-bolt flanges for port connection pads.

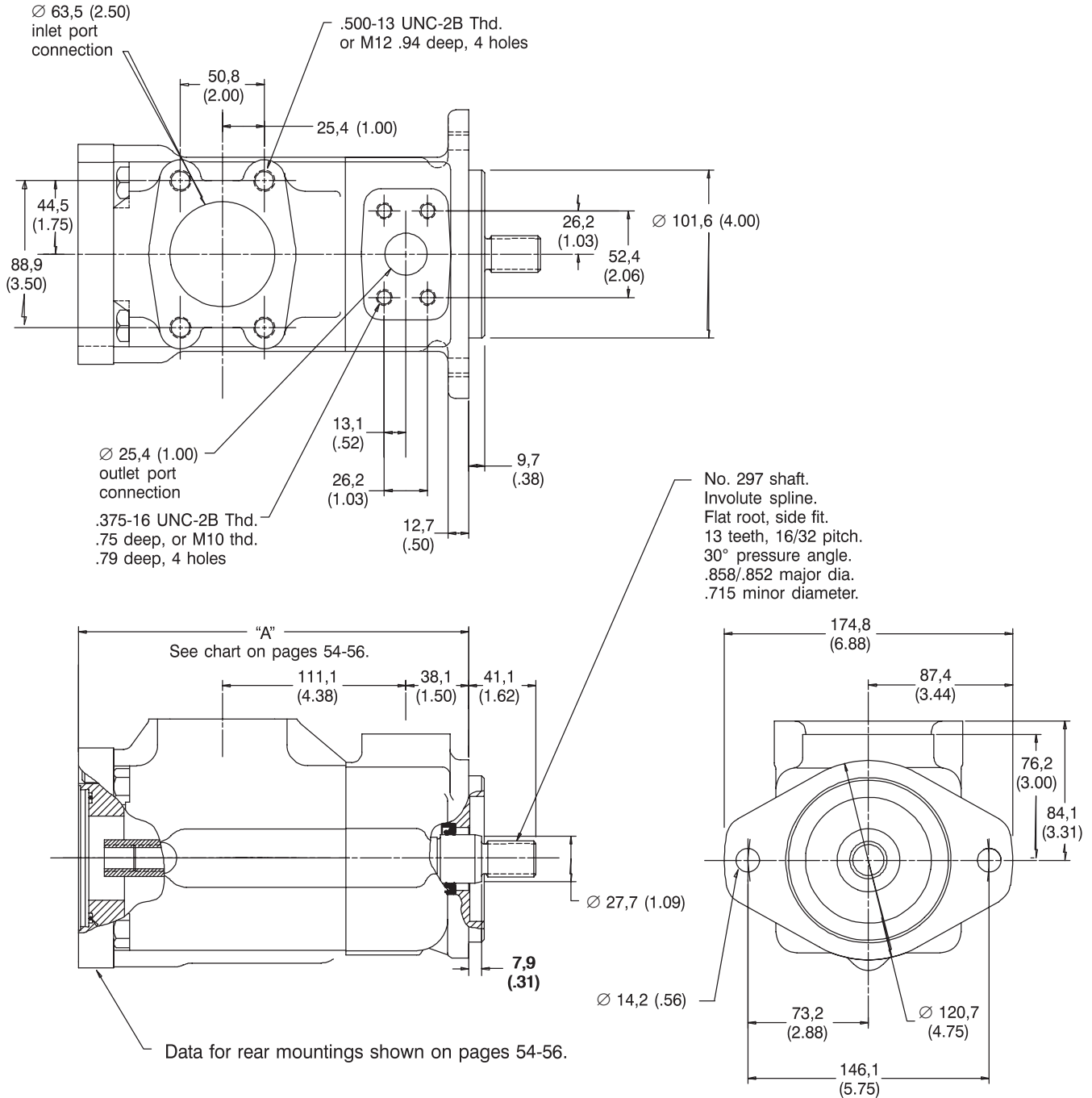

35VQT*S Series

Dimensions in millimeters (inches)

Shaft options are shown on page 58.

See page 121 for selection of SAE 4-bolt flanges for port connection pads.

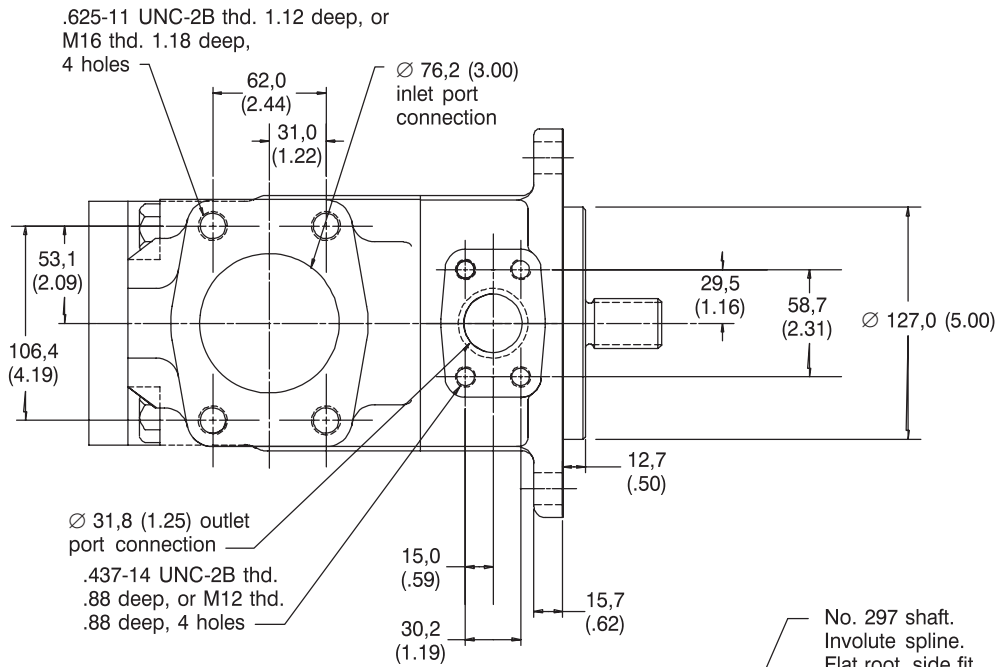

No. 297 shaft.
 Involute spline.
 Flat root, side fit.
 14 teeth, 12/24 pitch.
 30° pressure angle.
 1.229/1.223 major dia.
 1.04 minor diameter.

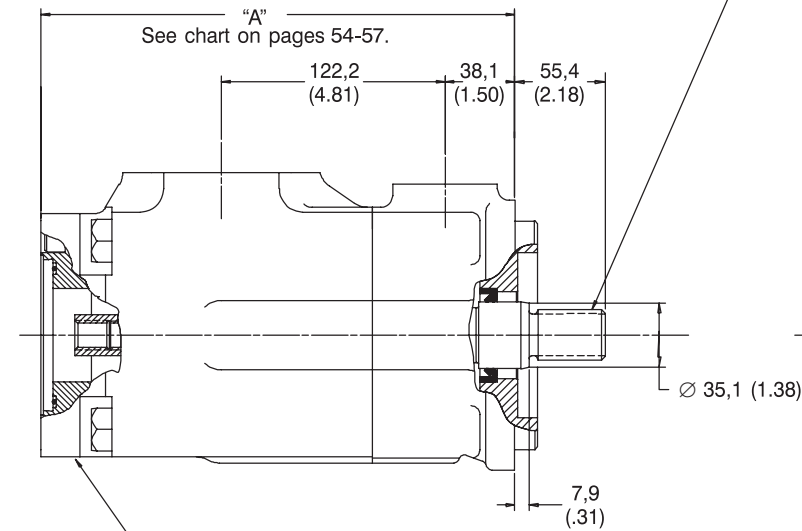

Data for rear mountings shown on pages 54-57

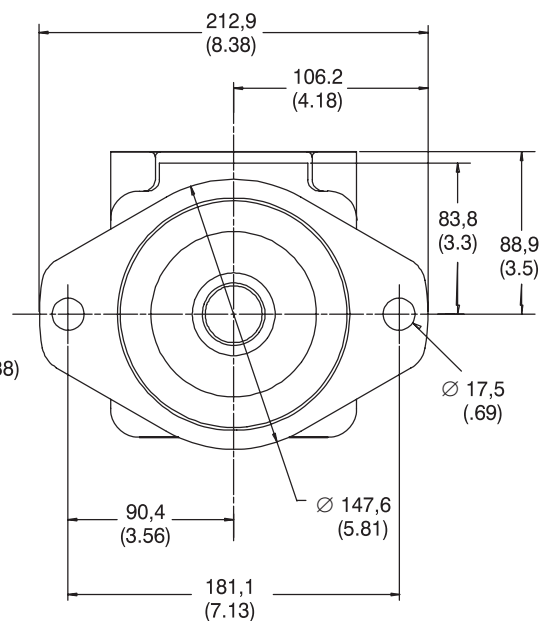

Installation Dimensions

45VQT*S Series

Dimensions in millimeters (inches)

Shaft options are shown on page 58.

See page 121 for selection of SAE 4-bolt flanges for port connection pads.

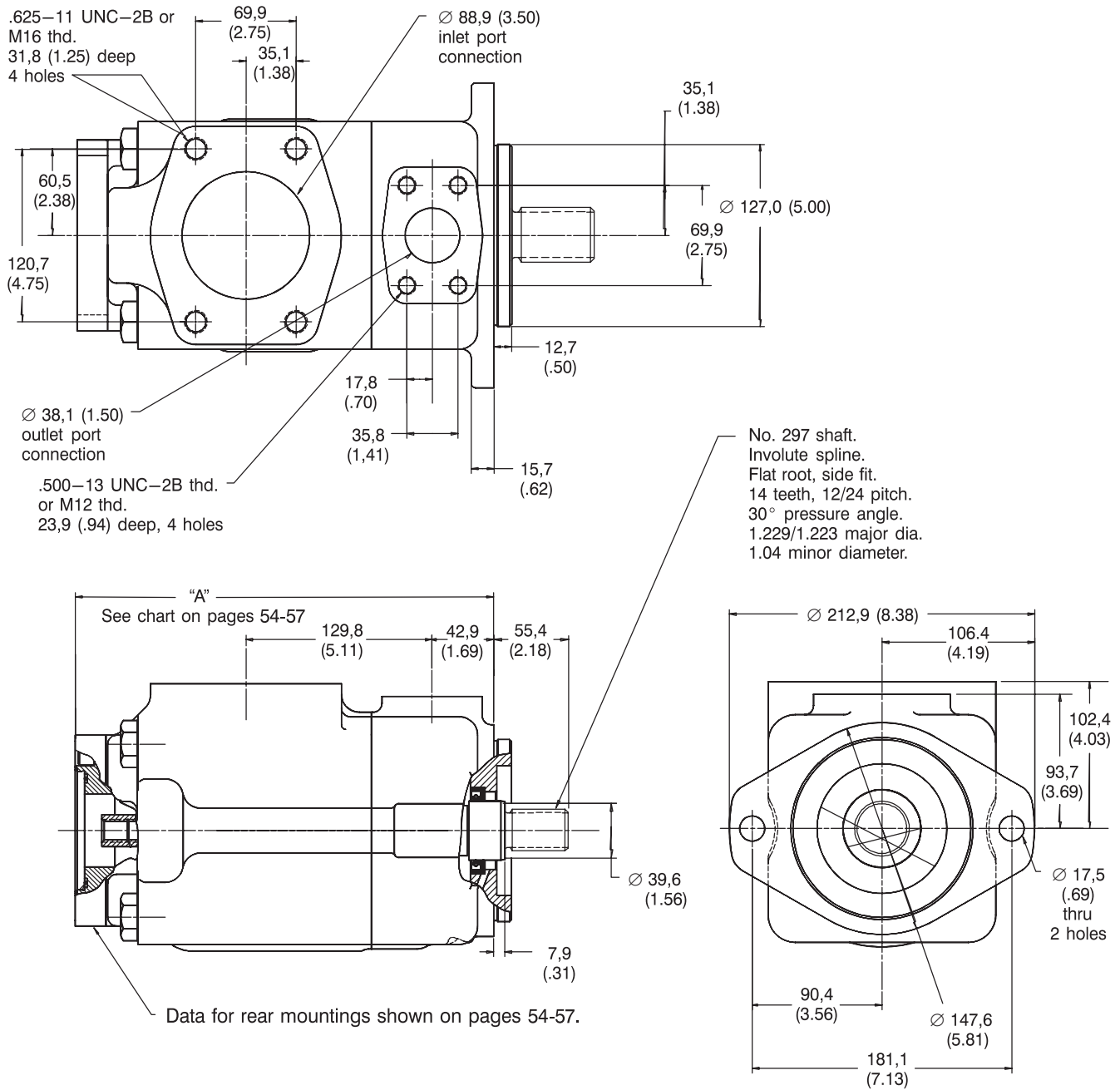

Thru-drive Rear Mountings

"A" rear mounting

Dimensions in millimeters (inches)

This unit accepts a hydraulic pump with a mounting configuration of the 82-2 (A) size per SAE std. J-744 Oct '83. The output coupling is for a pump shaft of SAE "A" size with a 30° involute spline (per SAE std J-744 Oct '83), 9T and 16/32 D.P. (Per ANSI B.92.1a1976). Concentricity of the shaft of the attached pump must meet or exceed requirements of SAE Std. J-744 Oct '83.

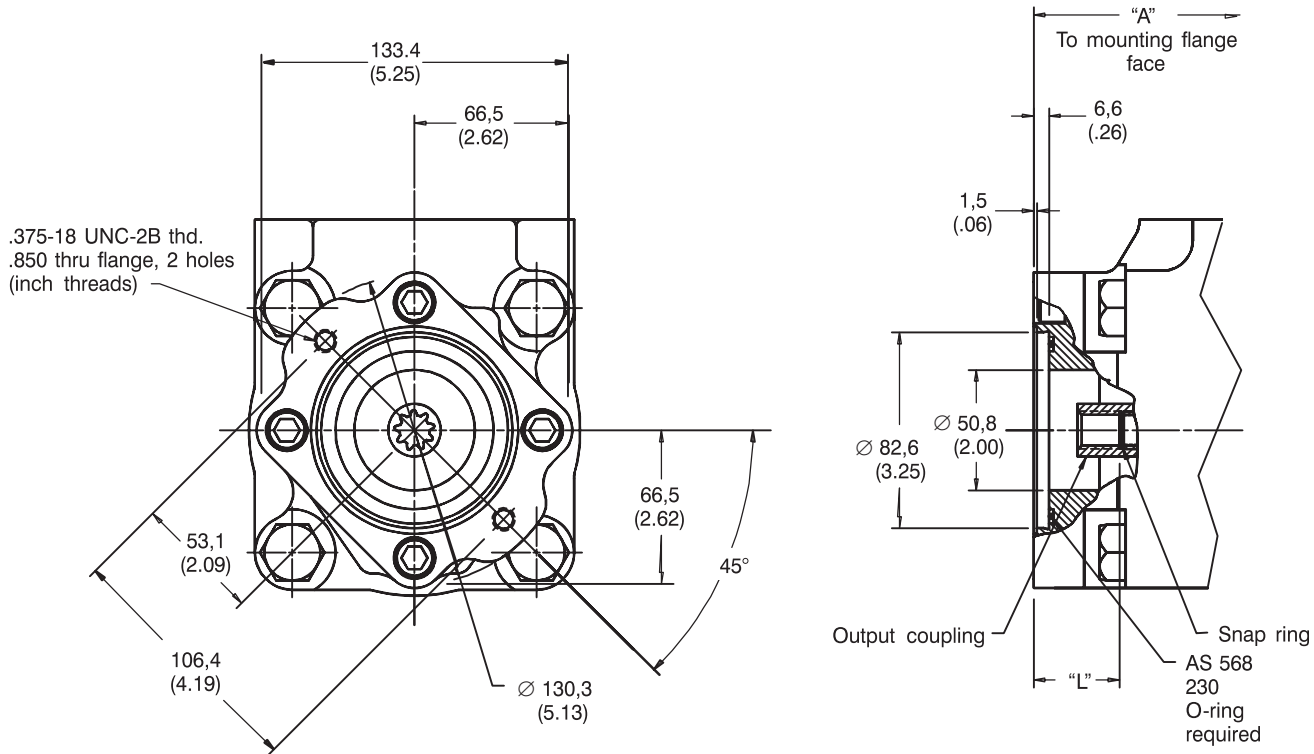

Pump model	Dimension "A"	"	Dimension "L"	*
25VQTAS	236, 2	(9.3)	32,5/31,0	(1.28/1.22) 33,0 (1.30) maximum
35VQTAS	259,1	(10.2)	32,5/31,0	(1.28/1.22) 35,6 (1.40) maximum
45VQTAS	292,1	(11.5)	32,5/31,0	(1.28/1.22) 35,3 (1.39) maximum

* CAUTION: Dimension "L" is important and must be observed.

Thru-drive Rear Mountings

"B" rear mounting

Dimensions in millimeters (inches)

This unit accepts a hydraulic pump with a mounting configuration of the 101-2 (B) size per SAE std. J-744 Oct '83. The output coupling is for a pump shaft of SAE "B" size with a 30° involute spline (per SAE std J-744 Oct '83), 13T and 16/32 D.P. (Per ANSI B.92.1a1976). Concentricity of the shaft of the attached pump must meet or exceed requirements of SAE Std. J-744 Oct '83.

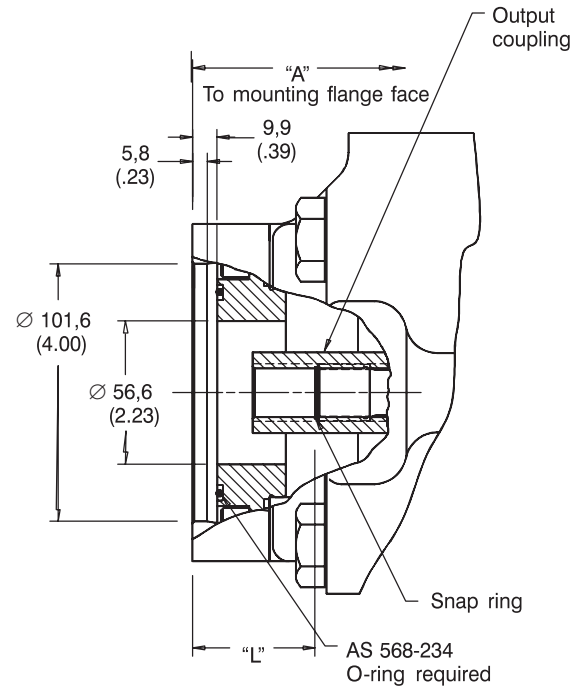
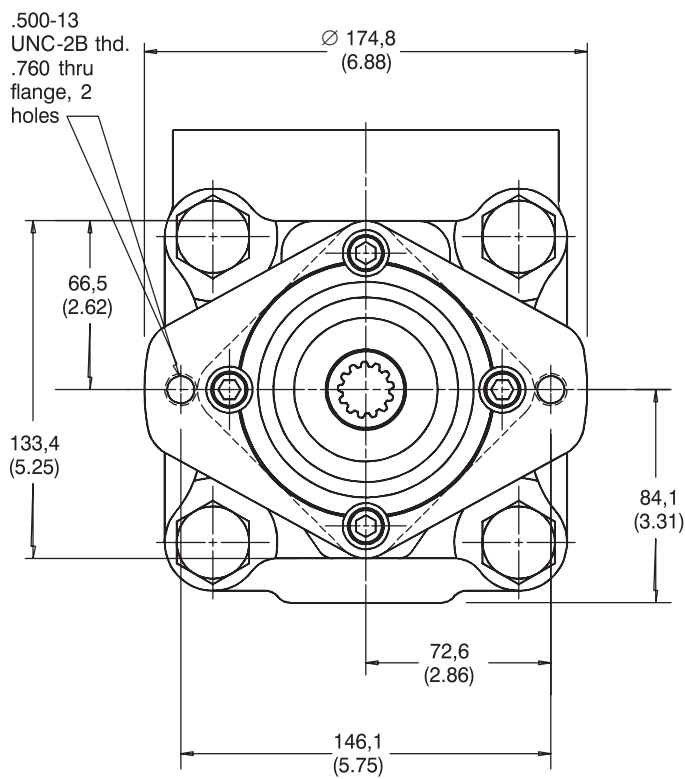

NOTE: For mounting PVE12/19/21, use "BP" adapter.

Pump model	Dimension "A" "	Dimension "L" *
25VQTBS	246,4 (9.7)	42,4/39,9 (1.67/1.57) 45,2 (1.78) maximum
35VQTBS	269,2 (10.6)	42,4/39,9 (1.67/1.57) 46,7 (1.84) maximum
45VQTBS	299,7 (11.8)	42,4/39,9 (1.67/1.57) 46,2 (1.82) maximum

* CAUTION: Dimension "L" is important and must be observed.

"BP" rear mounting

Dimensions in millimeters (inches)

This SAE "B" size unit with spacer accepts a Danfoss PVE12/19/21 pump. The output coupling is for a pump shaft of SAE "B" size with a 30° involute spline (per SAE std J-744 Oct '83), 13T and 16/32 D.P. (Per ANSI B.92.1a1976).

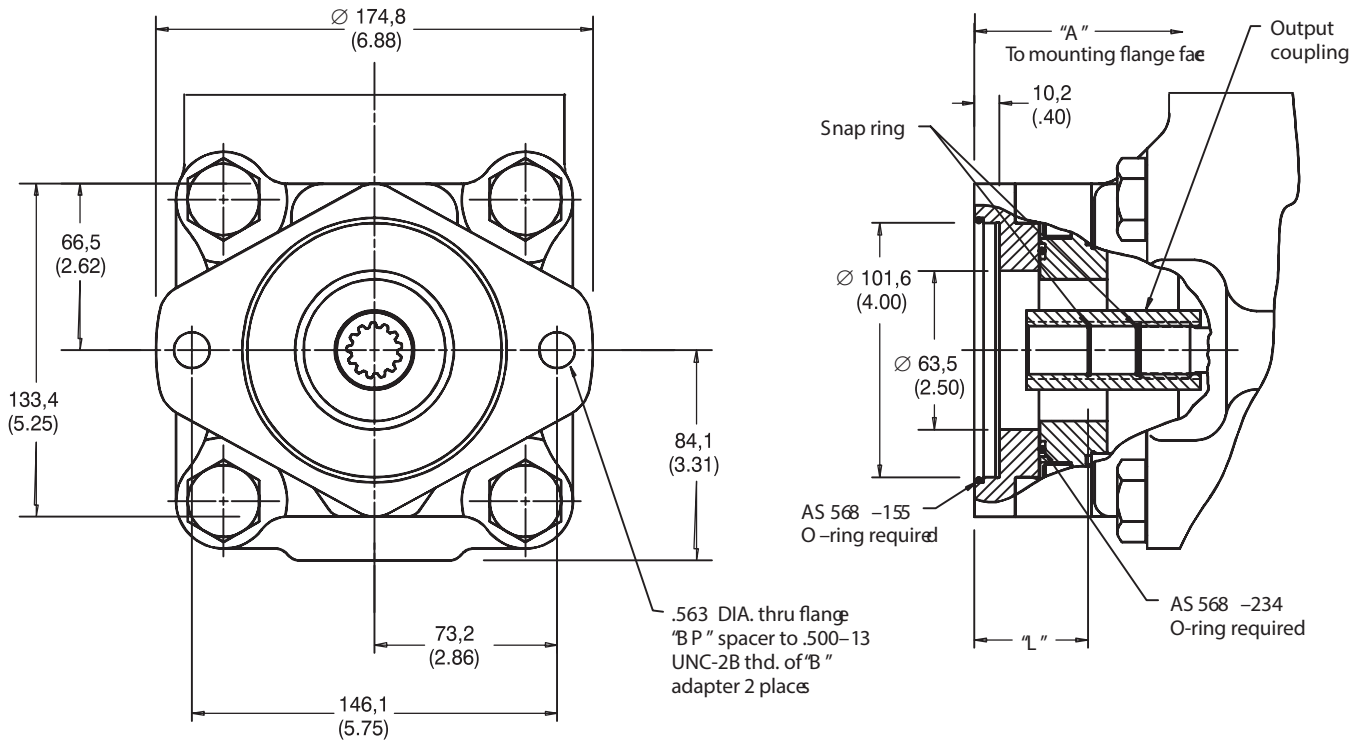

Pump model	Dimension "A" "	Dimension "L" *
25VQTBPS	261,9 (10.31)	45,7/43,2 (1.80/1.70) Not SAE std.
35VQTBPS	284,5 (11.20)	45,7/43,2 (1.80/1.70) Not SAE std.
45VQTBPS	317,0 (12.48)	45,7/43,2 (1.80/1.70) Not SAE std.

* CAUTION: Dimension "L" is important and must be observed.

Thru-drive Rear Mountings

"C" rear mounting

Dimensions in millimeters (inches)

This unit accepts a hydraulic pump with a mounting configuration of the 127-2 (C) size per SAE std. J-744 Oct '83. The output coupling is for a pump shaft of SAE "C" size with a 30° involute spline (per SAE std J-744 Oct '83), 14T and 12/24 D.P. (Per ANSI B.92.1a1976). Con- centricty of the shaft of the attached pump must meet or exceed requirements of SAE Std. J-744 Oct '83.

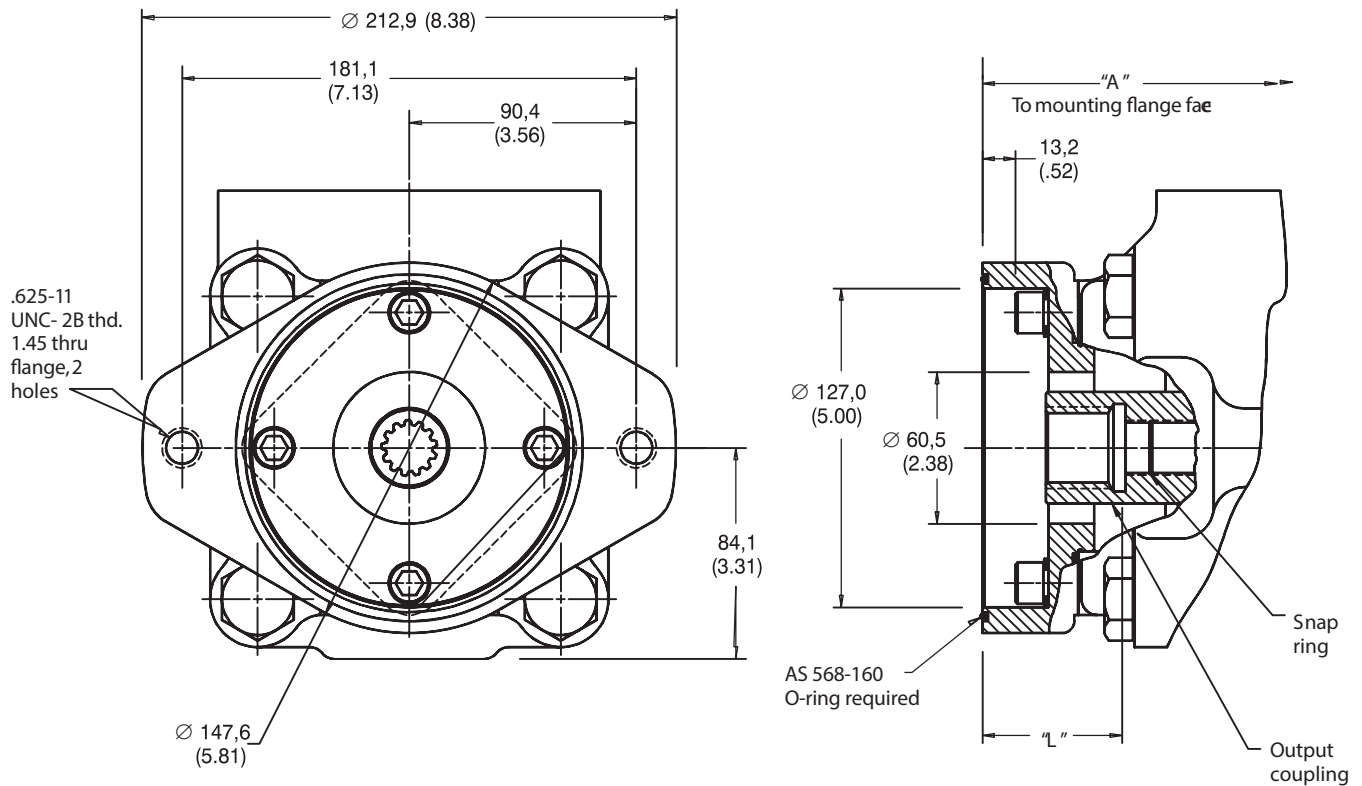

Pump model	Dimension "A" "	Dimension "L" *
35VQTCS	276,9 (10.9)	56,6/54,1 (2.23/2.13)
		61,2 (2.41) maximum
45VQTCS	307,3 (12.1)	56,6/54,1 (2.23/2.13)
		61,5 (2.42) maximum

* CAUTION: Dimension "L" is important and must be observed.

Optional Shafts

#203 Straight keyed heavy duty shaft
 Dimensions in millimeters (inches)

Note: No. 297 spline shaft shown on pages 51-53.

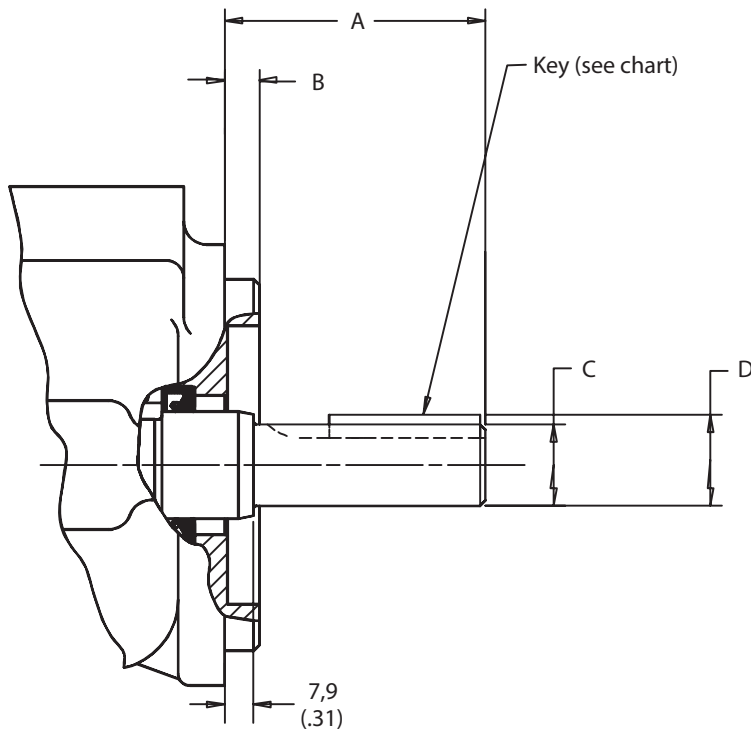

Dimensions

Model	A	B	Ø C	D	Key
25VQT*S	77,7 (3.06)	9,53 (.375)	25,40 (1.000)	28,19 (1.110)	6,35 (.250) sq. x 50,8 (2.00)
			25,35 (.998)	27,94 (1.100)	
35VQT*S	84,1 (3.31)	12,7 (.500)	34,90 (1.374)	38,56 (1.518)	7,94 (.313) sq. x 54,0 (2.13)
			34,87 (1.373)	38,30 (1.508)	
45VQT*S	90,4 (3.56)	12,7 (.500)	38,07 (1.499)	42,37 (1.668)	9,53 (.375) sq. x 57,2 (2.25)
			38,05 (1.498)	42,11 (1.658)	

Maximum Torque Loading for Direct Drives

Single pumps

All listed shafts are satisfactory up to maximum pressures in "Pressure and speed limits" in operating data for each series.

Double pumps

Where both cartridges are to be on-load together, check that the sum of their separate torques, taken from the graph below (right), does not exceed the torque limit in shaft torque Table 1.

Single thru-drive pumps and triple pumps

Where both the thru-drive pump and its rear-mounted pump are to be on-load together, check that the sum of the torques generated will never exceed the torque limit in shaft torque Table 2. Also check that the torque required on the rear-mounted pump never exceeds the thru-drive torque limit in shaft torque Table 2.

Table 2

Single Thru-drive Pumps and Triple Pumps – Shaft Torque Ratings

Pump Model	Shaft No.	Max. Input Torque Nm (lb. in.)*	Thru-drive Connection	Max. Thru-drive Torque Nm (lb. in.)
25VQT	203	402 (3560)	A	131 (1160)
			B	316 (2800)
25VQT or 2520VQSV10	297	344 (3040)	A	131 (1160)
			B	316 (2800)
35VQT	203	659(5830)	A	131 (1160)
			B	348 (3080)
			C	437 (3870)
35VQT or 352*VQSV10	297	791 (7000)	A	131 (1160)
			B	348 (3080)
			C	437 (3870)
45VQT	203	982 (8690)	A	131 (1160)
			B	384 (3400)
			C	702 (6210)
45VQT or 45*5VQSV10	297	1017 (9000)	A	131 (1160)
			B	384 (3400)
			C	702 (6210)

* Combined torque of Vickers "VQT" pump and thru-driven pump

Table 2

Single Thru-drive Pumps and Triple Pumps – Shaft Torque Ratings

Pump Model	Shaft Number	Maximum Input Torque Nm (lb. in.)*
25VQ or 25**VQ	1	316 (2800)
	86	402 (3560)
	11	316 (2800)
	123	316 (2800)
	203	402 (3560)
35VQ or 35**VQ	1	402 (3560)
	11	791 (7000)
	86	659 (5830)
	123	791 (7000)
	203	659 (5830)
45VQ or 45**VQ	1	402 (3560)
	11	1017 (9000)
	86	982 (8690)
	130	1017 (9000)
	203	982 (8690)
297	1017 (9000)	

Example:

A 3525VQ38A17 pump operating at 175 bar (2500 psi) front section and 140 bar (2000 psi) rear section will require over 452 Nm (4000 lb. in.) input torque. Therefore, all listed shafts are acceptable except No. 1.

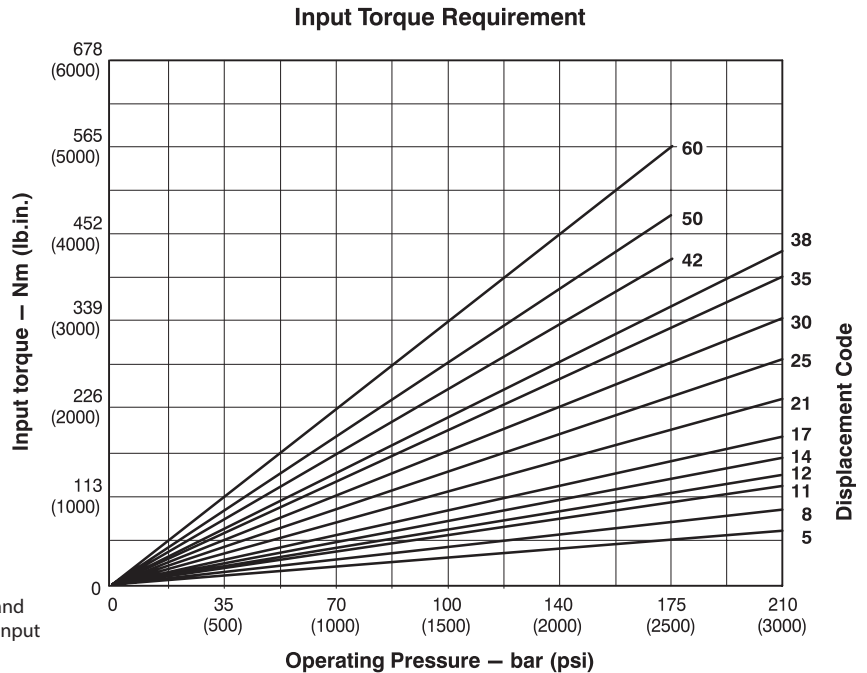

Double Thru-drive Pump Operating Specifications

Model Series	Displacement Code (USgpm at 1200 r/min and 7 bar (100 psi))		Displacement cm ³ /rev (in ³ /rev)	Rated Speed r/min	Maximum Pressure bar (psi)	Typical Delivery at Max Speed and Pressure l/min (USgpm)	Typical Input Power at Maximum Speed and Pressure kW (hp)
	Front Pump	Rear Pump					
	25		81,6 (4.98)	2500	207 (3000)	173,1 (45)	75 (101)
	30		97,7 (5.96)	2500	207 (3000)	211,5 (55)	88 (117.5)
	35		112,8 (6.88)	2400	207 (3000)	230,8 (60)	98 (132)
3525VQT	38		121,6 (7.42)	2400	207 (3000)	250,0 (65)	104 (140)
		12	40,2 (2.45)	2500	207 (3000)	79,0 (21)	38 (51)
		14	45,4 (2.77)	2500	207 (3000)	91,0 (24)	43 (58)
		17	55,2 (3.37)	2500	207 (3000)	119,2 (31)	51,8 (69,5)
		21	67,5 (4.12)	2500	207 (3000)	146,2 (38)	62 (83)
	42		138,7 (8.46)	2200	172 (2500)	255,8 (66.5)	91 (122.5)
	50		162,3 (9.90)	2200	172 (2500)	303,8 (79)	105 (141)
	60		193,4 (11.80)	2200	172 (2500)	369,2 (96)	127 (170)
4525VQT		12	40,2 (2.45)	2200	207 (3000)	68,0 (18)	33 (44)
		14	45,4 (2.77)	2200	207 (3000)	79,0 (21)	38 (51)
		17	55,2 (3.37)	2200	207 (3000)	100,0 (26.5)	45 (61)
		21	67,5 (4.12)	2200	207 (3000)	125,0 (33)	54 (73)

Performance constants: SAE 10W oil @ 82C (180F) and pump inlet @ 0 psig (14.7 psia).

Note: Outlet pressure must always be higher than inlet pressure. See page 8 for details.

Typical Performance

For thru-drive performance, use curves on the following pages:

Model Series	Page Number	
	Shaft-end Pump	Rear Pump
3525VQT	35	39
4525VQT	36	41

Model Codes

Thru-drive Double Pump

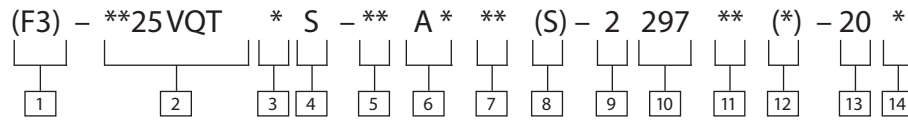

1 F3 - Viton seals
Omit if not required.

2 Series designation
3525VQT (standard bearing)
3625VQT (3525VQT with heavy duty bearing)
4525VQT (standard bearing)

3 Thru-drive (rear) 2-bolt mounting flange
A – SAE "A" flange
B – SAE "B" adapter flange
BP – SAE "B" spacer flange for Vickers PVE12, 19, or 21 pump

4 Front mounting flange
S – SAE J-744 (127-2)

5 Geometric displacement, shaft end pump
Code = SAE rating (USgpm) at 1200 rpm and 6,9 bar (100 psi)

Pump Series	Code	cm ³ /r	in ³ /r
3*25VQT	25	81,6	4.98
	30	97,7	5.96
	35	112,8	6.88
	38	121,6	7.42

4525VQT	42	138,7	8.46
	50	162,3	9.90
	60	193,4	11.80

6 Port connections
A – SAE 4-bolt flange
B – Metric 4-bolt flange (Flange pads stamped "M" for metric threads)

7 Geometric displacement, cover end pump
Code = SAE rating (USgpm) at 1200 rpm and 6,9 bar (100 psi)

Pump Series	Code	cm ³ /r	(in ³ /r)
**25VQT	12	40	2.45
	14	45	2.77
	17	55	3.37
	21	68	4.12

8 Shaft seal assembly
S – Single seal
– Omit for double seal

9 Thru-drive coupling
2 – With spline for tandem pump

10 Shaft
297 – Splined
"C" size per SAE J744C
32-4 per SAE J744 Oct '83

11 Port position
(Viewed from cover end of pump)
With no. 1 outlet opposite inlet
AA – No. 2 outlet 135 ° CCW from inlet
AB – No. 2 outlet 45 ° CCW from inlet
AC – No. 2 outlet 45 ° CW from inlet
AD – No. 2 outlet 135 ° CW from inlet

With no. 1 outlet 90 ° CCW from inlet
BA – No. 2 outlet 135 ° CCW from inlet
BB – No. 2 outlet 45 ° CCW from inlet
BC – No. 2 outlet 45 ° CW from inlet
BD – No. 2 outlet 135 ° CW from inlet

With no. 1 outlet in line with inlet
CA – No. 2 outlet 135 ° CCW from inlet
CB – No. 2 outlet 45 ° CCW from inlet
CC – No. 2 outlet 45 ° CW from inlet
CD – No. 2 outlet 135 ° CW from inlet

With no. 1 outlet 90 ° CCW from inlet
DA – No. 2 outlet 135 ° CCW from inlet
DB – No. 2 outlet 45 ° CCW from inlet
DC – No. 2 outlet 45 ° CW from inlet
DD – No. 2 outlet 135 ° CW from inlet

12 Thru-drive (rear) mounting flange position
(Viewed from cover end of pump)
A – In line with no. 2 outlet port in all cases
B – 90° from no. 2 outlet port in all cases
– Omit for **25VQTA models

13 Design
Subject to change. Installation dimensions remain unchanged for designs 20 through 29.

14 Shaft rotation
(Viewed from shaft end of pump)
L – Left hand (counterclockwise)
R – Right hand (clockwise)

NOTE:

State complete model number when ordering. Example: 3525VQTAS-25A12-2297CC-20R. Port flange kits with inch screws are available from Vickers and must be ordered separately. For port flange kits, or mounting, displacement, port, and shaft options other than coded above, contact your Vickers representative.

Installation Dimensions

3525VQT Series

Dimensions in millimeters (inches)

Port connection pads are for use with SAE or metric 4-bolt flanges. Pads stamped with "M" for metric threads. See page 121 for selection of SAE flanges.

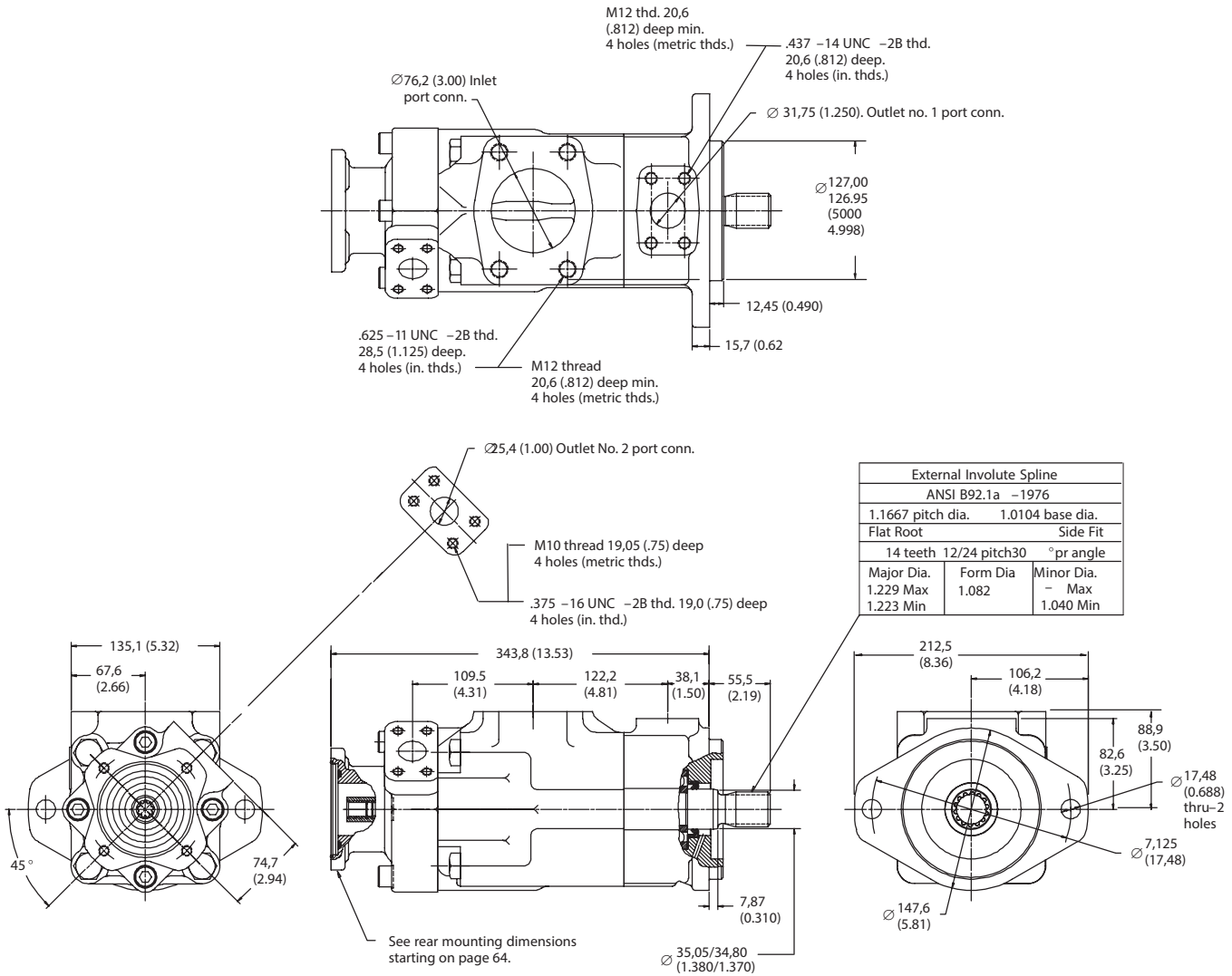

Installation Dimensions

4525VQT Series

Dimensions in millimeters (inches)

Port connection pads are for use with SAE or metric 4-bolt flanges. Pads stamped with "M" for metric threads. See page 121 for selection of SAE flanges.

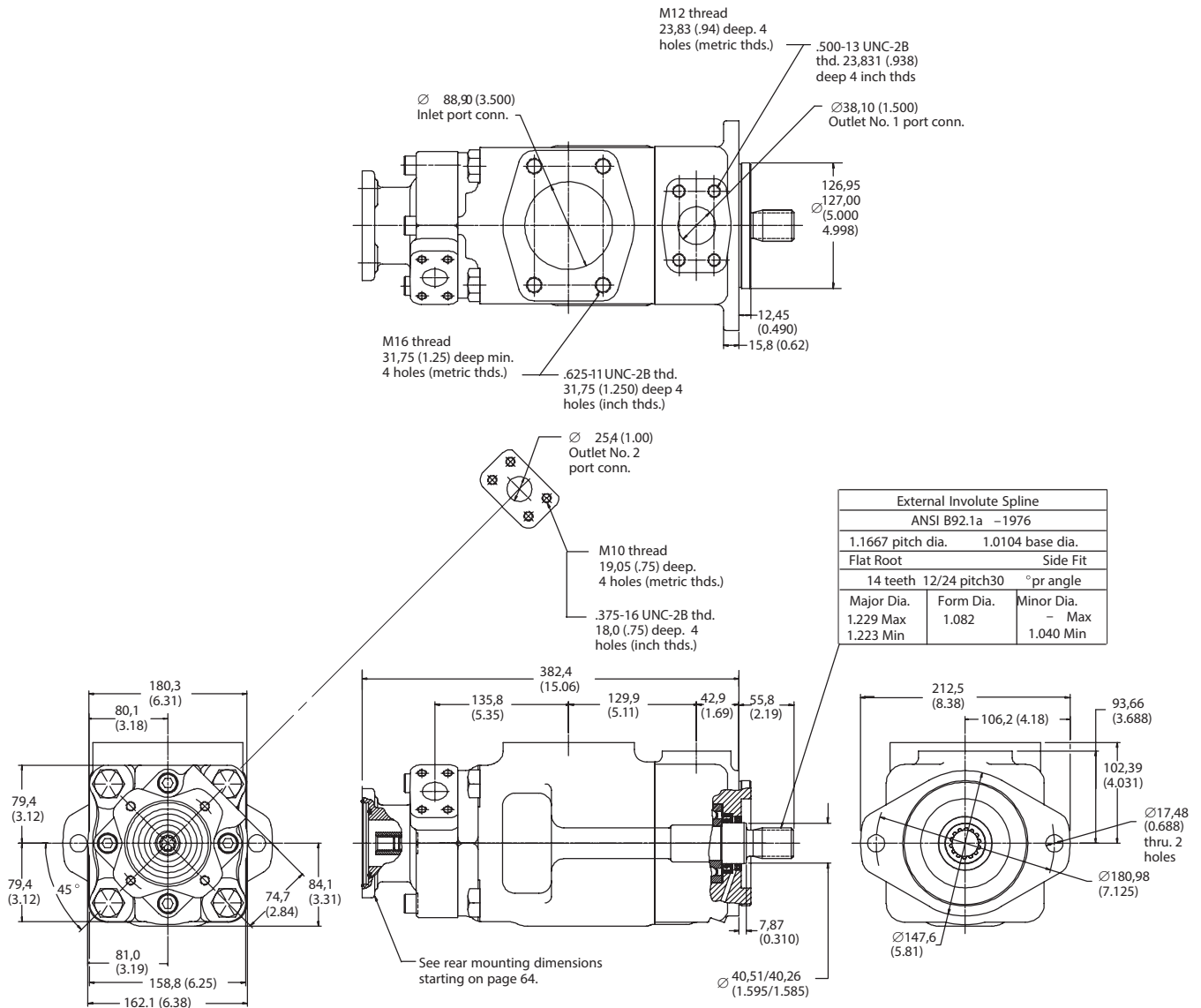

Rear Mountings for Thru-drive Double Pumps

"A" Rear Mounting
(SAE 82-2 size).

Dimensions in millimeters (inches)

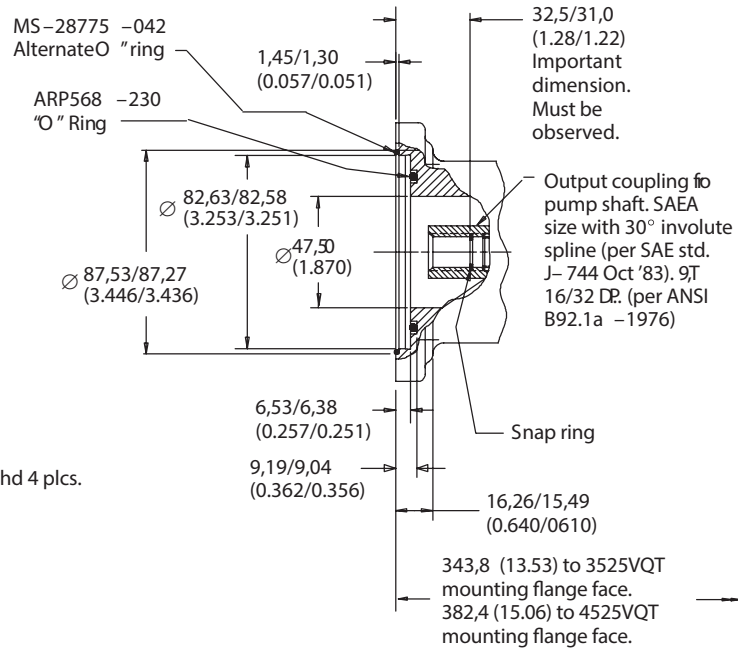
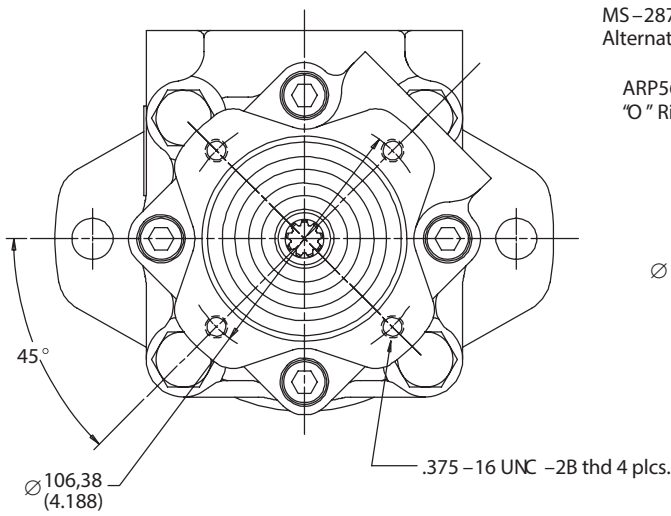

"B" Rear Mounting
(SAE 101-2 size).

Dimensions in millimeters (inches)

This unit accepts hydraulic pump with SAE mounting configuration of 101-2(B) size per SAE std. J-744 Oct '83.

NOTE: Concentricity of shaft of attached product must be to SAE std. J-744 Oct.'83 or better.

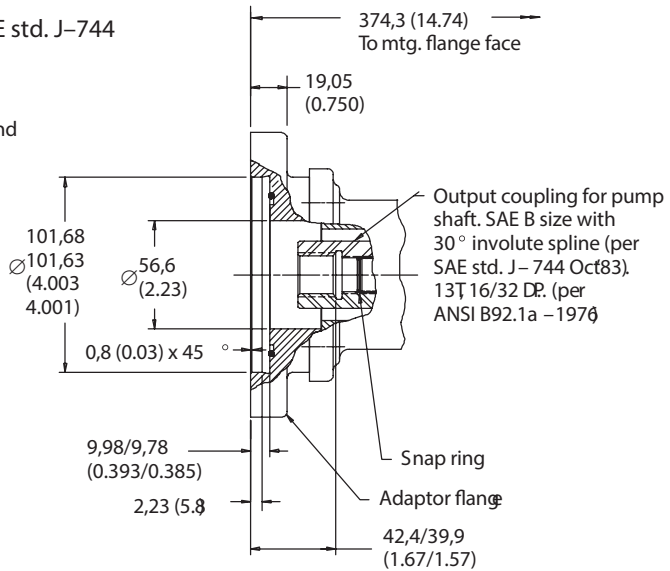
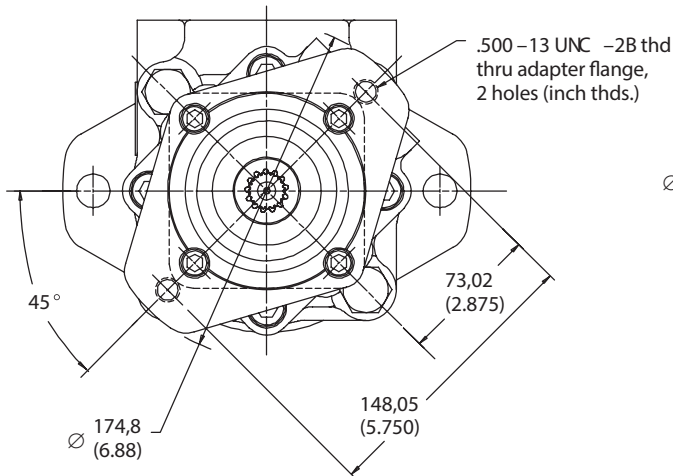

Rear Mountings for Thru-drive Double Pumps

"BP" Rear Mounting
 (SAE B size with spacer for Danfoss PVE19/21 pumps)

Dimensions in millimeters (inches)

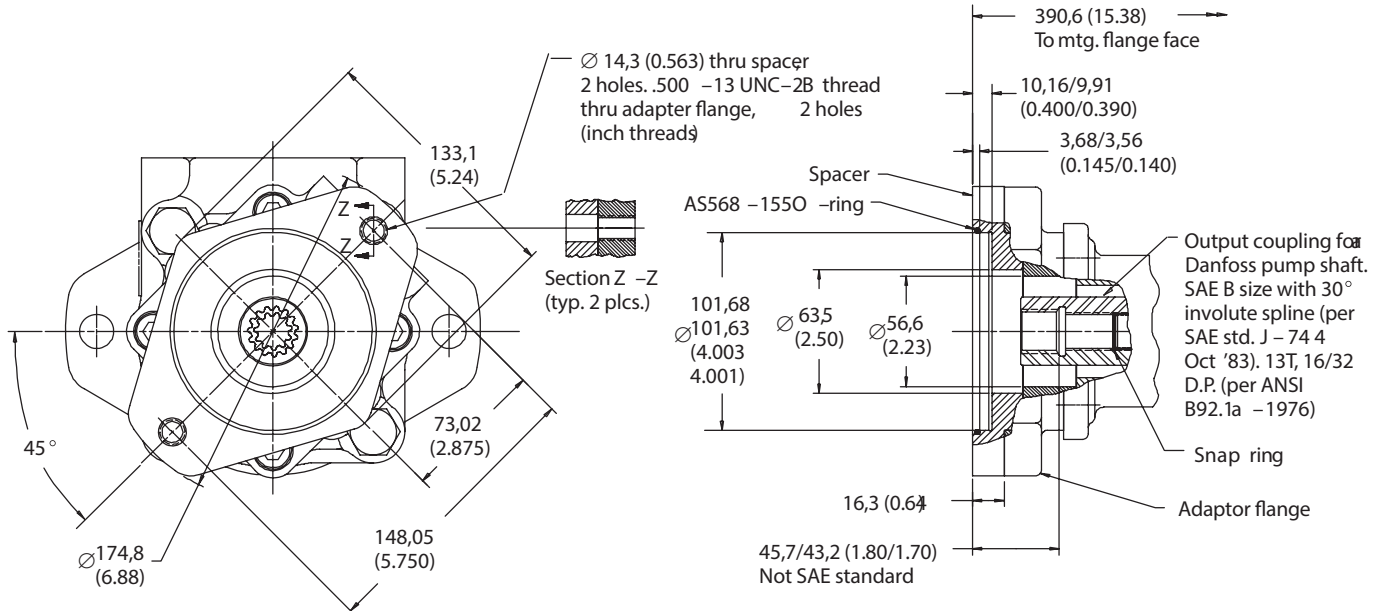

Maximum Torque Loading for Direct Drives

Double Thru-drive Pumps

As pictured at right, a coupled double VQT pump and thru-driven pump are essentially three pumps driven by one drive shaft. It is critical that the sum of the torque required for each pumping section not exceed the maximum torque capability of the drive shaft.

Use the following procedure to ensure proper loading on the drive shaft:

1. Determine maximum operating torque of pumping section #1 from "Front Pump Torque Requirements" figure #1 or #2 at right.
2. Determine maximum operating torque of pumping section #2 from "Rear Pump Torque Requirements" figure #3 on following page.
3. Determine maximum operating torque of thru-driven pump (pumping section #3) from its specific catalog data, or estimate the torque using the following formula:

$$\text{Torque} = (1.15 \times \text{displacement} \times \text{pressure}) \div 6.28$$

Note: Actual torque may be higher or lower than estimated.

4. Ensure the torque determined for the #3 pumping section does not exceed the "Maximum Thru-drive Torque" for the double VQT pump in figure #4 on following page.
5. Sum all torque values from steps 1, 2 and 3 above. This value must not exceed the "Maximum Input Torque" value in figure #4 on following page.

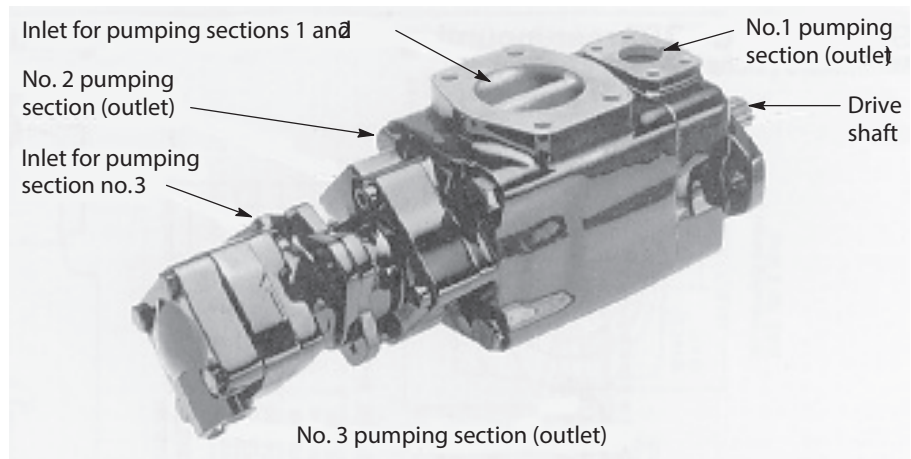

Figure 1

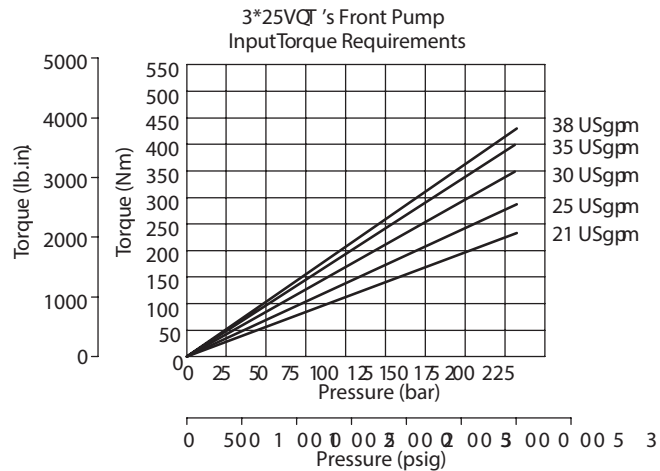
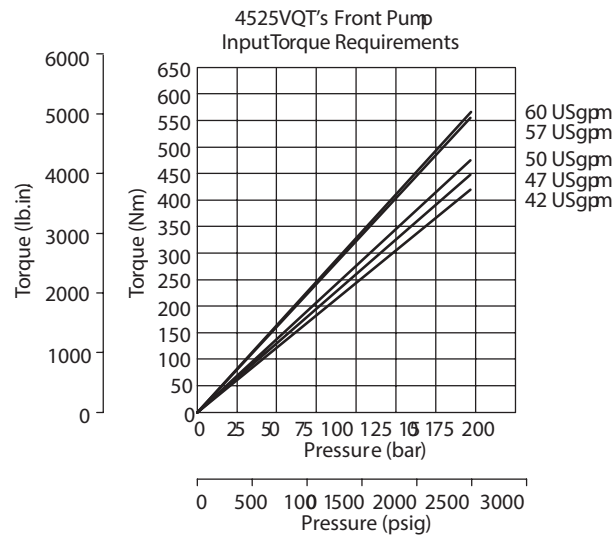

Figure 2



Maximum Torque Loading for Direct Drives

Figure 3

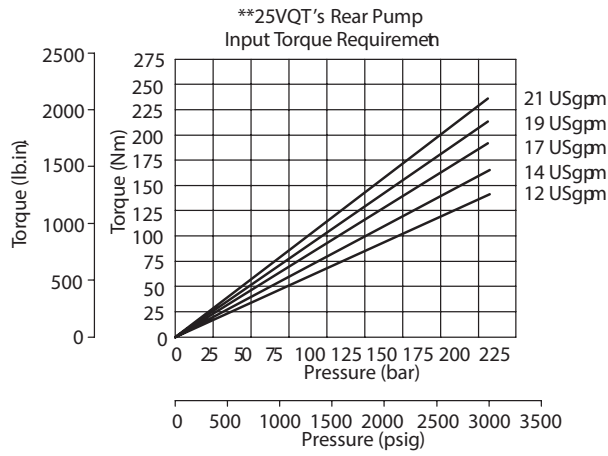

Figure 4

Model Series	Max. Torque – Nm (lb in)	
	Input †	Thru-drive
3*25VQTA	790 (7000)	131 (1160)
3*25VQTB	790 (7000)	316 (2800)
3*25VQTBP	790 (7000)	316 (2800)
4525VQTA	1017 (9000)	131 (1160)
4525VQTB	1017 (9000)	316 (2800)
4525VQTBP	1017 (9000)	316 (2800)

† Combined torque of Danfoss thru-drive double pump and thru-driven pump.

Typical Rear-mounted Pumps for **25VQT Thru-drive Assemblies

Mounting	Piston Pump Model Series	Shaft Code	Vane Pump Model Series	Shaft Code
SAE A	PVQ10/13	3	V10	11
			V20	62
SAE B	PVQ20/32	3	20V	15
	PVQ40/45	3	25V	11
	PVE12	2	V2020	11
	PVE19/21	9		

NOTE: Torque limits in Figure 4 must not be exceeded when applying the above Vickers pumps.

V10, V20, V2010 & V2020 Single & Double Pumps

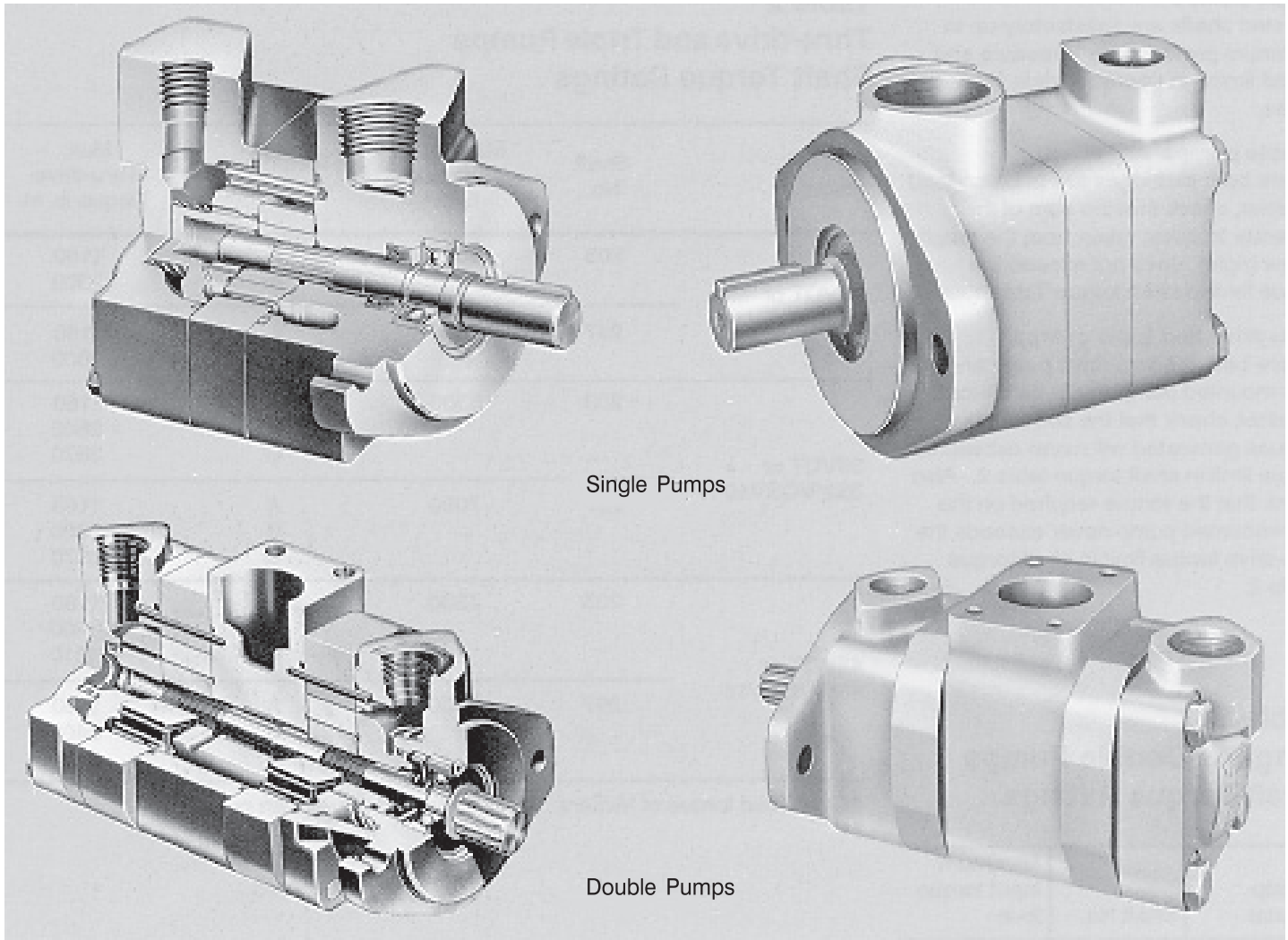

Single Pumps

Double Pumps

- Versatile**
High flow, pressure and speed capabilities enable these pumps to meet the needs of modern vehicle hydraulic circuits. Optional flow control and priority valve covers offer even more versatility.
- Flow Control**
The flow control cover limits flow to the operating system to the desired maximum. Excess flow is diverted to tank. On double pumps, shaft-end pump delivery is proportional to speed. The flow control cover also includes a relief valve to limit maximum system pressure. A typical application of a flow control is in a power steering unit where it provides a constant supply of oil over the engine's mid to high speed range.
- Priority Valve**
The priority valve cover maintains nearly a constant flow to a primary circuit and diverts the remaining flow to a secondary circuit. Flow going to the secondary circuit is determined by pump delivery. The primary circuit is protected by an integral relief valve but an external relief valve must be provided for the secondary circuit.
- Reliable**
The superior design of these units makes them last longer ... they've proven they'll hold up in rugged applications such as trenchers, backhoes and tractors.
- Hydraulic Balance**
Internal inlet and outlet pressure chambers are diametrically opposed. As a result, pressure-induced radial loads are balanced ... bearings have to carry the external load only.
- Performance**
Low vane tip/ring loading allows high pressure operation. High speeds are possible because the inlet flow paths are designed to give uniform oil acceleration - thus better filling - particularly at low inlet pressures.
- Low Cost**
Danfoss' efficient design produces extra horsepower per dollar of pump investment - providing industry with low pump cost per horsepower capacity.

Single Pump Operating Specifications

Model Series	Delivery USgpm @ 1200 r/min 7 bar (100 psi)	Displ. cm ³ /r (in ³ /r)	Max. r/min	Max. bar (psi)	Typical del. L/min (USgpm) @ max. speed & pressure	Typical input kW (hp) @ max. speed & pressure	Wt. kg (lb.)
V10 V10F V10P	1	3,3 (.20)	4800	172 (2500)	13,6 (3.6)	5,2 (7)	4,5 - 6,8 (10 - 15)
	2	6,6 (.40)	4500	172 (2500)	27,7 (7.3)	10,1 (13.6)	
	3	9,8 (.60)	4000	172 (2500)	35,6 (9.4)	13,3 (17.8)	
	4	13,1 (.80)	3400	172 (2500)	41,3 (10.9)	15,2 (20.4)	
	5	16,4 (1.00)	3200	172 (2500)	48,5 (12.8)	17 (22.8)	
	6	19,5 (1.19)	3000	152 (2200)	55,3 (14.6)	18,3 (24.5)	
	7	22,8 (1.39)	2800	138 (2000)	60,6 (16)	17,9 (24)	
V20 V20F V20P	6	19,5 (1.19)	3400	172 (2500)	61,0 (16.1)	21,6 (29)	7,3 - 8,2 (16 - 18)
	7	22,8 (1.39)	3000	172 (2500)	63,3 (16.7)	22 (29.5)	
	8	26,6 (1.62)	2800	172 (2500)	67,1 (17.7)	24,2 (32.5)	
	9	29,7 (1.81)	2800	172 (2500)	75,0 (19.8)	26,5 (35.5)	
	11	36,4 (2.22)	2500	172 (2500)	86,8 (22.9)	28 (37.5)	
	12	39 (2.38)	2400	152 (2200)	87,2 (23)	26,8 (36)	
	13	42,5 (2.59)	2400	152 (2200)	98,1 (25.9)	29,1 (39)	

Note: Review "Applying Vane Units" page 7 prior to selection of pump.

Model Codes

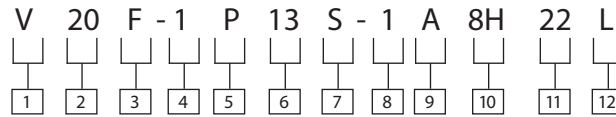

1 Vane pump

2 Series 10 or 20

3 Integral valve options (Omit if not required) F – Flow control & relief P – Priority valve & relief

4 Mounting 1 – 2-bolt flange 6 – 2 bolt flange (SAE “B” size)

5 Inlet port connections D – 1 5/16-12 str. thd. (V20 only) P – 1” NPT thread (V10 only) 1 1/4” NPT thread (V20 only) S – 1 5/16-12 str. thd. (V10 only) 1 5/8”-12 str. thd. (V20 only) T – 1 3/16-12 str. thd. (V10 only)

6 SAE rated capacity – USgpm (1200 r/min & 100 psi)

1	– 4 L/min (1 USgpm)	V10 series
2	– 8 L/min (2 USgpm)	
3	– 11 L/min (3 USgpm)	
4	– 15 L/min (4 USgpm)	
6	– 23 L/min (6 USgpm)	
7	– 27 L/min (7 USgpm)	
6	– 23 L/min (6 USgpm)	
7	– 27 L/min (7 USgpm)	
8	– 30 L/min (8 USgpm)	
9	– 34 L/min (9 USgpm)	
11	– 42 L/min (11 USgpm)	
12	– 45 L/min (12 USgpm)	
13	– 49 L/min (13 USgpm)	

7 Outlet port connections

Code	Std. cover	Flow control cover		Priority valve cover		
		Pressure	Tank	Primary outlet	Secondary outlet	Tank
K	–	–	–	9/16-18 St. thd. (V10P)	3/4-16 St. thd. (V10P)	9/16-18 St. thd. (V10P)
P	1/2” NPT thd. (V10 only)	–	–	–	–	–
	3/4” NPT thd. (V20 only)	3/4-16 St. thd. (V10F & V20F)	1/2” NPT thd. (V10F & V20F)	–	–	–
S	3/4”-16 St. thd. (V10 only)	–	–	–	–	–
	1-1/16-12 St. thd. (V20 only)	3/4-16. St. thd (V20F)	1-1/16-12 St. thd. (V20F)	–	–	–
T	–	3/4-16 St. thd. (V10F)	3/4-16 St. thd. (V10F)	3/4-16 St. thd. (V20P)	7/8-14 St. thd. (V20P)	3/4-16 St. thd. (V20P)

8 Shafts 1 – Straight keyed 3 – Threaded with woodruff key 11 – Splined 12 – Splined (V10 only) 38 – Splined 62 – SAE A Spline (V20 only)

9 Position of outlet or primary outlet port (Viewed from cover end of pump) A – Opposite inlet port B – 90° CCW from inlet C – In line with inlet D – 90° CW from inlet

10 Integral valves

Orifice No.	Relief valve setting	
Flow rate	A – 17 bar (250 psi)	H – 140 bar (2000 psi)
2 – 8 L/min (2 USgpm)	B – 35 bar (500 psi)	J – 155 bar (2250 psi)
3 – 11 L/min (3 USgpm)	C – 52 bar (750 psi)	K – 175 bar (2500 psi)
4 – 15 L/min (4 USgpm)	D – 70 bar (1000 psi)	
5 – 19 L/min (5 USgpm)	E – 86 bar (1250 psi)	
6 – 23 L/min (6 USgpm)	F – 100 bar (1500 psi)	
7 – 27 L/min (7 USgpm)	G – 121 bar (1750 psi)	
8 – 30 L/min (8 USgpm)		

11 Design Subject to change. Installation dimen - sions remain the same for designs –20 through –29.

12 Shaft Rotation (Viewed from shaft end of pump) L – Left hand for counterclockwise. Omit for right hand.

Installation Dimensions

V10 Series

Dimensions in millimeters (inches).
Shaft options shown on page 74.

Delivery @
1200 rpm
& 100 psi

	Dimensions	
	A	B
1 USgpm	115,6 (4.55)	91,9 (3.62)
2 USgpm	115,6 (4.55)	91,9 (3.62)
3 USgpm	115,6 (4.55)	91,9 (3.62)
4 USgpm	121,9 (4.80)	98,3 (3.87)
5 USgpm	121,9 (4.80)	98,3 (3.87)
6 USgpm	127,0 (5.00)	103,4 (4.07)
7 USgpm	127,0 (5.00)	103,4 (4.07)

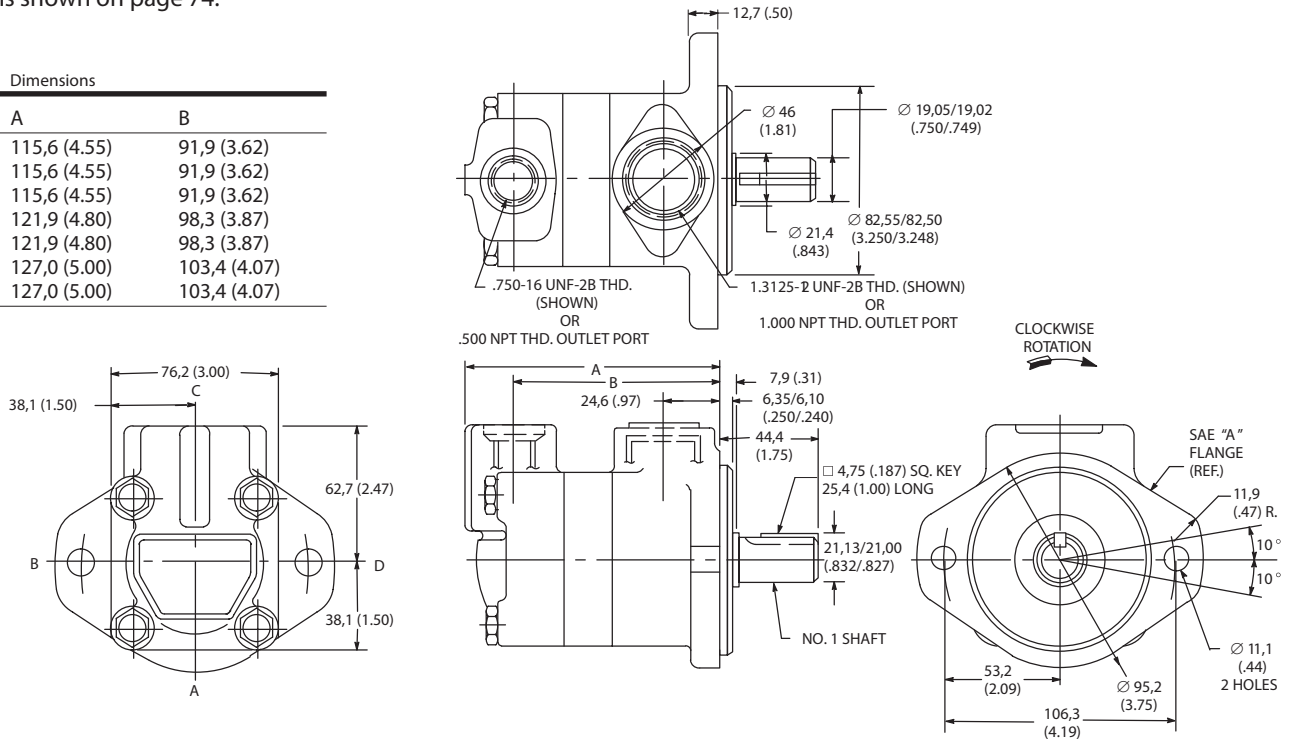

V10F Series

Dimensions in millimeters (inches).
Shaft options shown on page 74.

Delivery @
1200 rpm
& 100 psi

	Dimensions	
	A	B
1 USgpm	128,8 (5.07)	109,5 (4.31)
2 USgpm	128,8 (5.07)	109,5 (4.31)
3 USgpm	128,8 (5.07)	109,5 (4.31)
4 USgpm	135,1 (5.32)	115,8 (4.56)
5 USgpm	135,1 (5.32)	115,8 (4.56)
6 USgpm	140,2 (5.52)	120,9 (4.76)
7 USgpm	140,2 (5.52)	120,9 (4.76)

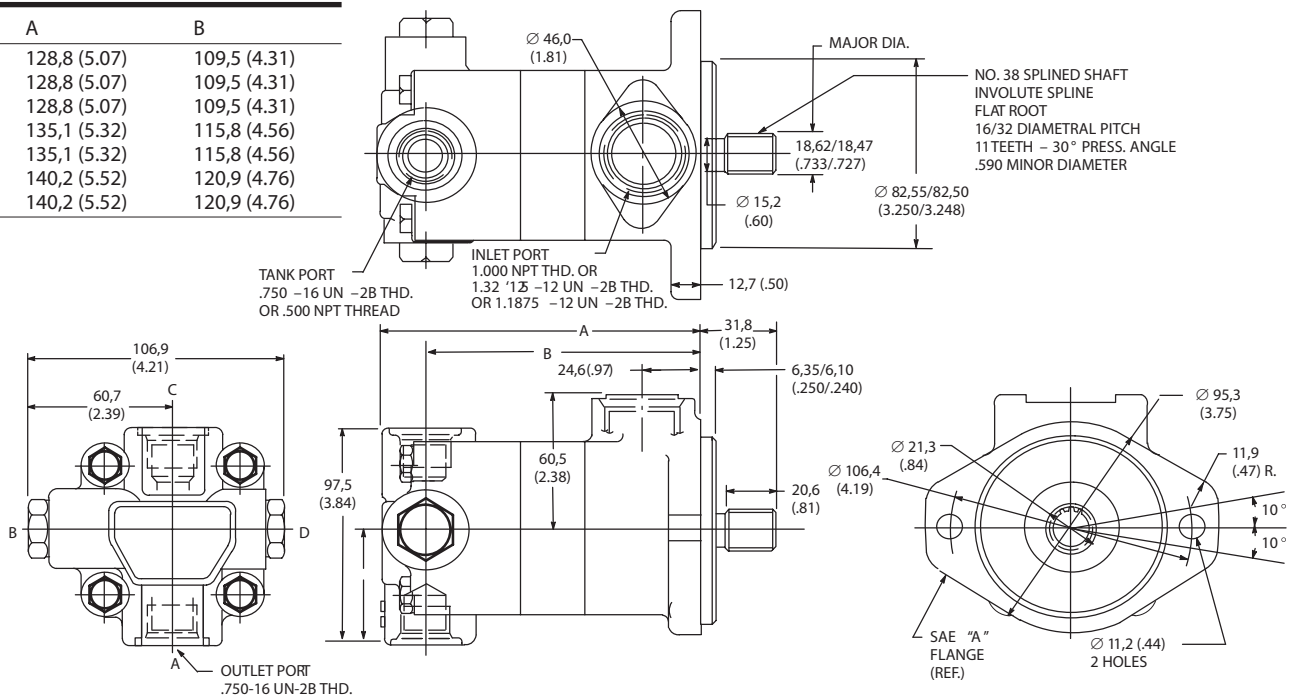

V10P Series

Dimensions in millimeters (inches).
Shaft options shown on page 74.

Delivery @
1200 rpm
& 100 psi

Dimensions

	A	B
1 USgpm	130,0 (5.12)	109,5 (4.31)
2 USgpm	130,0 (5.12)	109,5 (4.31)
3 USgpm	130,0 (5.12)	109,5 (4.31)
4 USgpm	136,4 (5.37)	115,8 (4.56)
5 USgpm	136,4 (5.37)	115,8 (4.56)
6 USgpm	141,5 (5.57)	120,9 (4.76)
7 USgpm	141,5 (5.57)	120,9 (4.76)

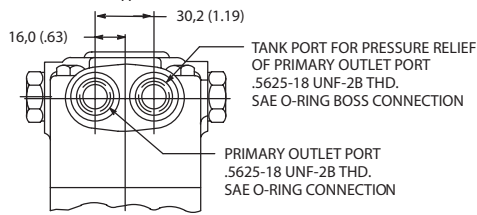
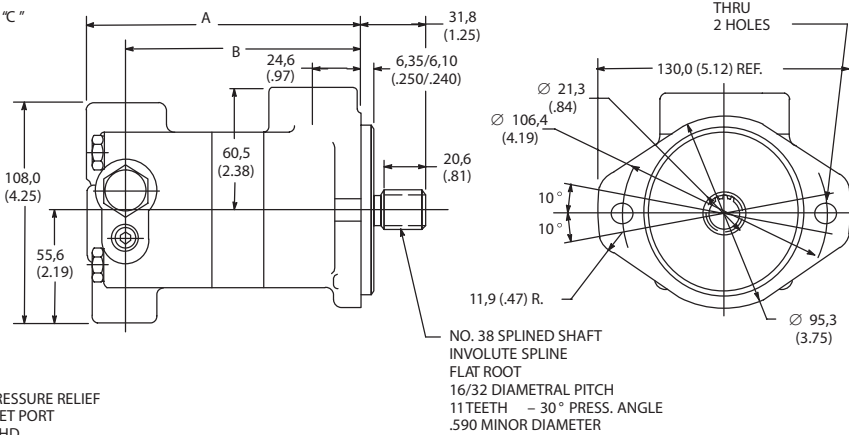
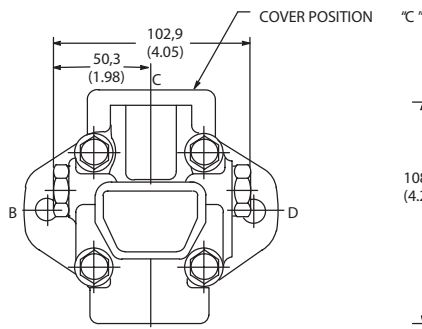
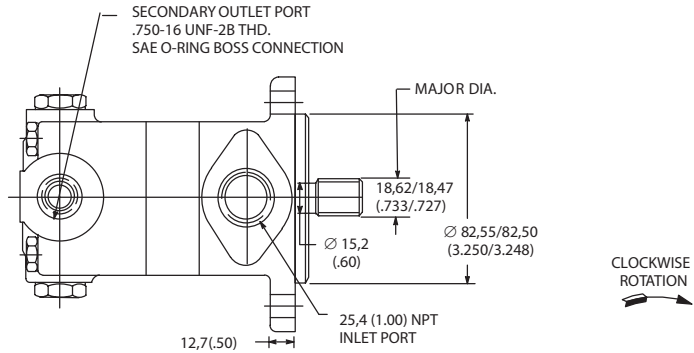

V20 Series

Dimensions in millimeters (inches).
Shaft options shown on page 74.

Delivery @
1200 rpm
& 100 psi

Dimensions

	A	B
6 USgpm	125,2 (4.93)	102,1 (4.02)
7 USgpm	131,6 (5.18)	108,4 (4.27)
8 USgpm	131,6 (5.18)	108,4 (4.27)
9 USgpm	131,6 (5.18)	108,4 (4.27)
11 USgpm	136,6 (5.38)	113,5 (4.47)
12 USgpm	140,2 (5.52)	117,1 (4.61)
13 USgpm	140,2 (5.52)	117,1 (4.61)

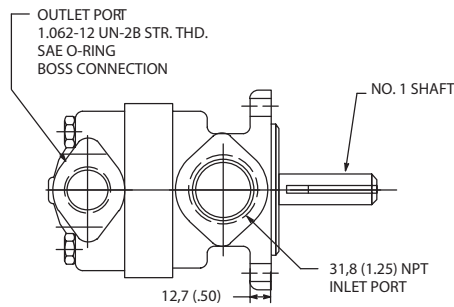

CLOCKWISE
ROTATION

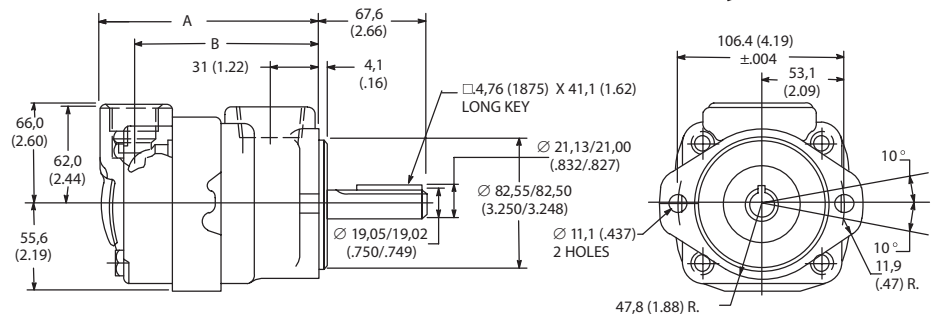
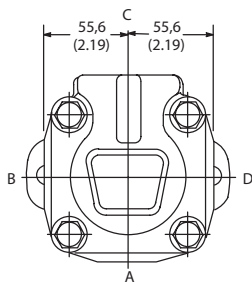

Installation Dimensions

V20F & V20P Series

Dimensions in millimeters (inches).

Shaft options shown on page 74.

Delivery @
1200 rpm
& 100 psi

	Dimensions	
	A	B
6 USgpm	149,6 (5.89)	125,7 (4.95)
7 USgpm	156,0 (6.14)	132,1 (5.20)
8 USgpm	156,0 (6.14)	132,1 (5.20)
9 USgpm	156,0 (6.14)	132,1 (5.20)
11 USgpm	161,0 (6.34)	136,9 (5.39)
12 USgpm	164,3 (6.47)	140,5 (5.53)
13 USgpm	164,3 (6.47)	140,5 (5.53)

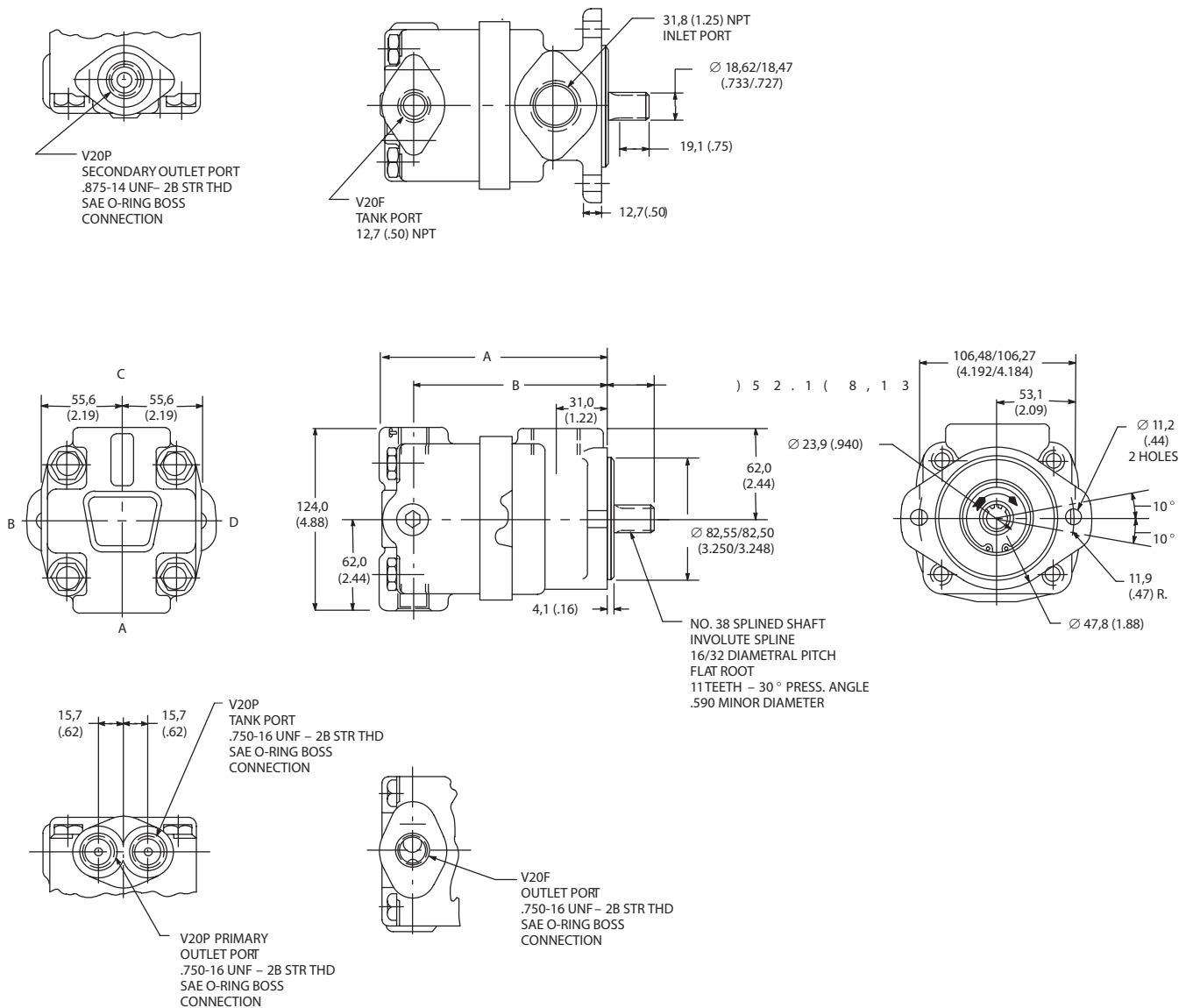

Optional Shafts

V10 Series

Dimensions in millimeters (inches)

Note: No. 1 keyed shaft and No. 38 splined shaft shown on pages 71 and 72 respectively.

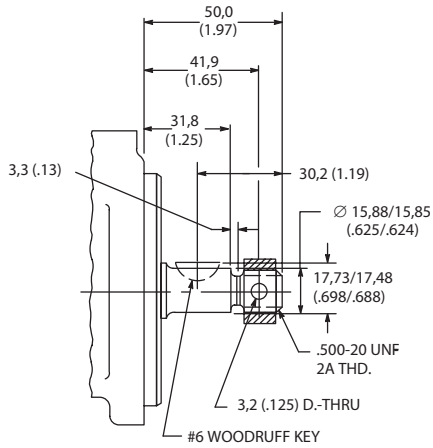

No. 3 shaft extension

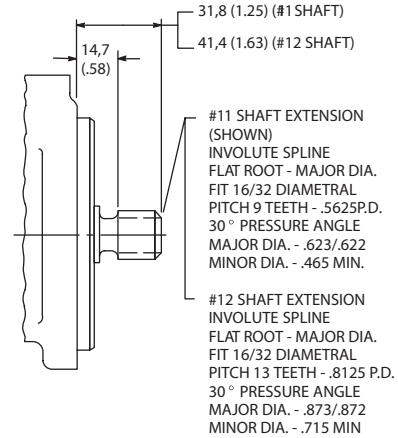

No. 11 & 12 shaft extension

V20 Series

Dimensions in millimeters (inches)

Note: No. 1 keyed shaft and No. 38 splined shaft shown on pages 72 and 73 respectively. No. 62 splined shaft same as V10 #11 shaft shown above.

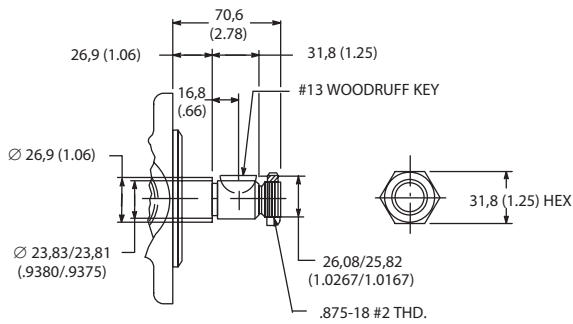

No. 3 shaft extension

Note: No. 3 shaft recommended nut torque 170 Nm (125 lb. ft.)

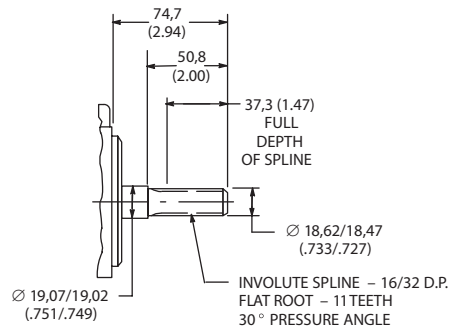

No. 11 shaft extension

Typical Performance

V10 Single Pumps

Performance Constants:

Oil temp. 49° C (120° F), viscosity 32 cSt (150 SSU) @ 38° C (100° F), inlet pressure zero

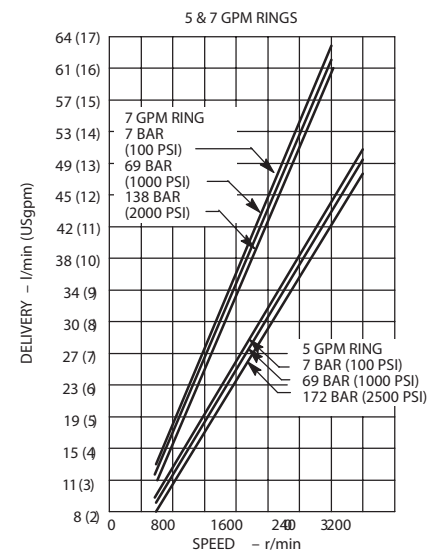
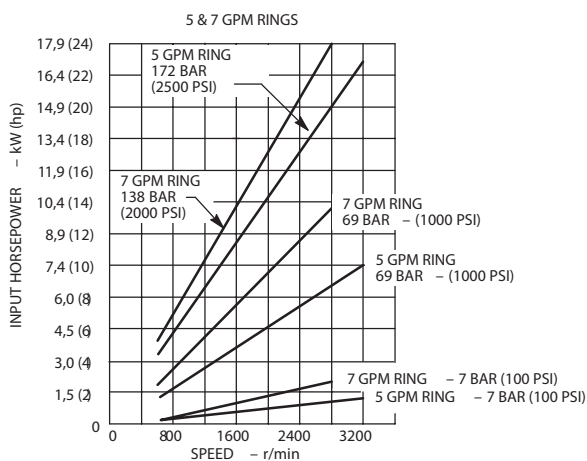
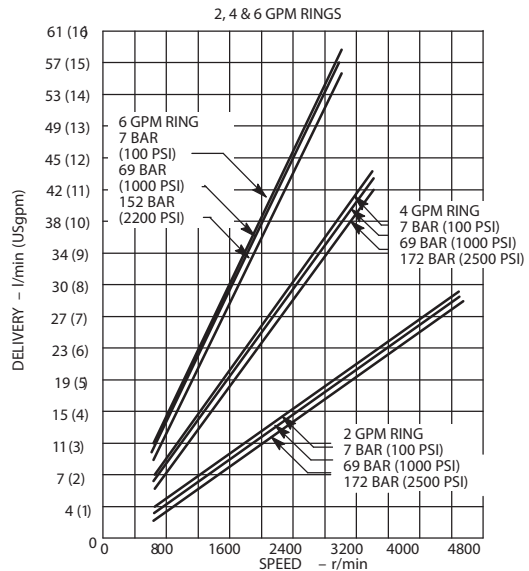
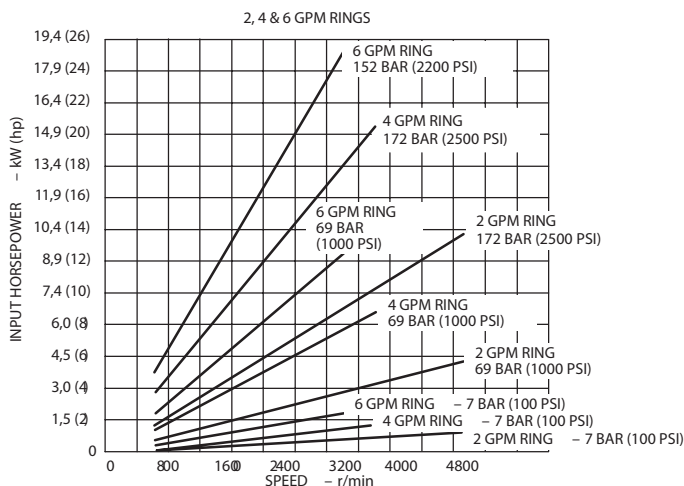
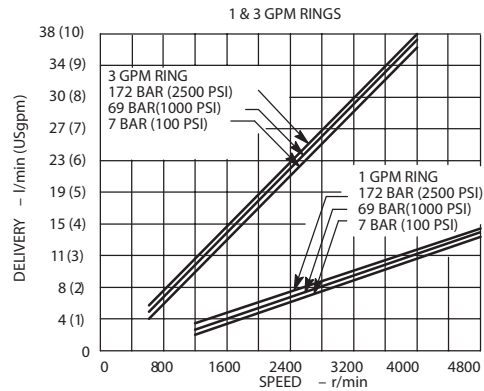
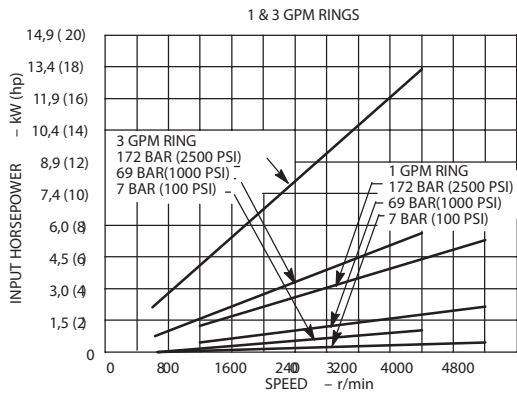

V20 Single Pumps

Performance Constants:

Oil temp. 49° C (120° F), viscosity 32 cSt (150 SSU) @ 38° C (100° F), inlet pressure zero

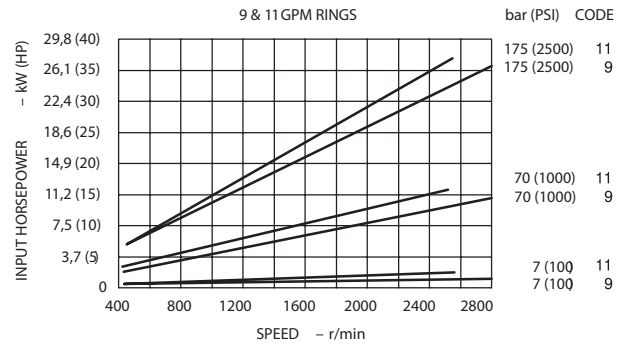
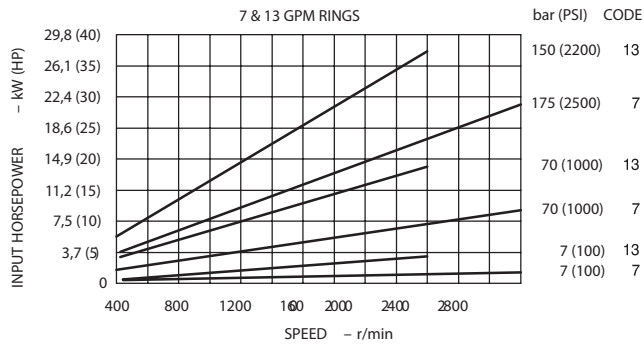
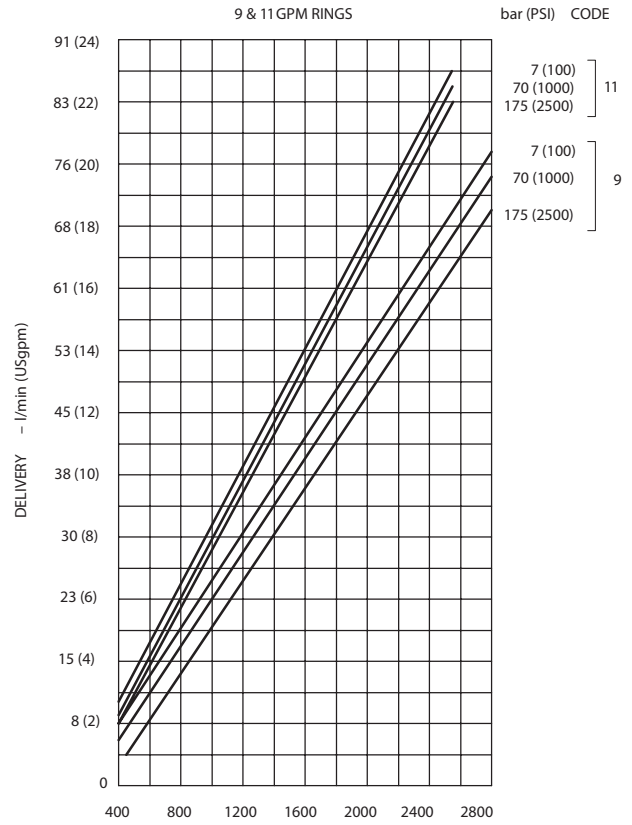
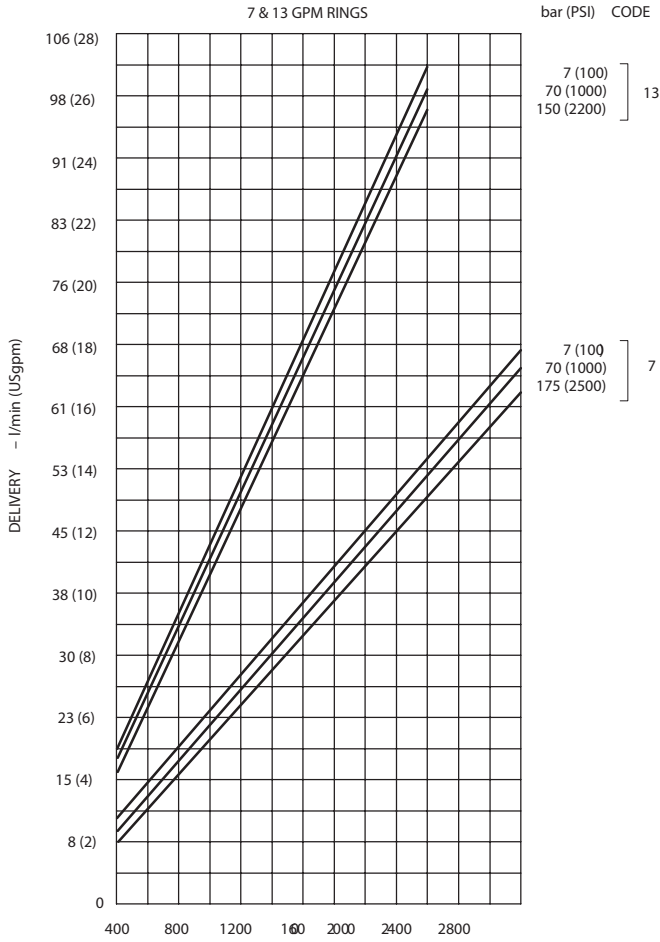

Typical Performance

V20 Single Pumps

Performance Constants:

Oil temp. 49° C (120° F), viscosity 32 cSt (150 SSU) @ 38° C

(100° F), inlet pressure zero

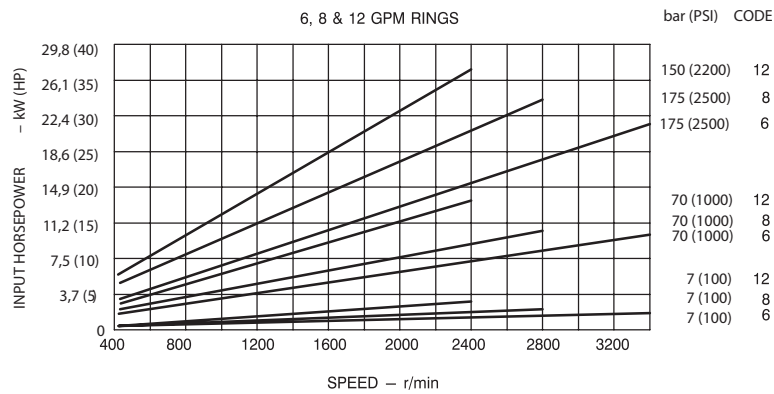
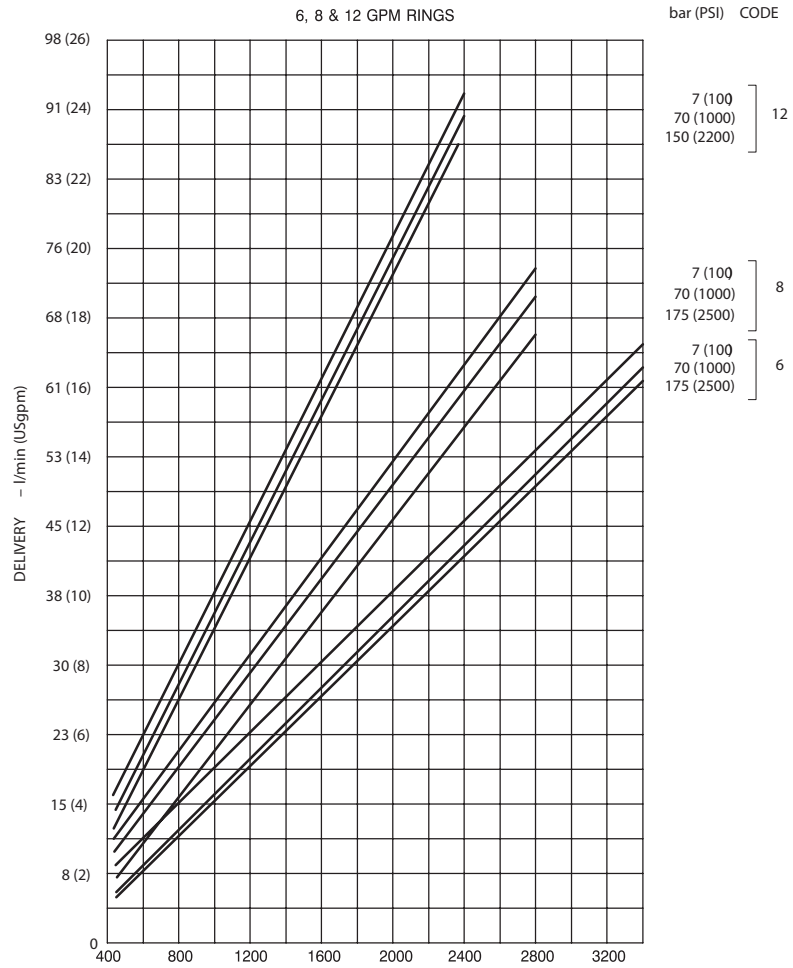

Priority Valve Models

V10P Single Pumps

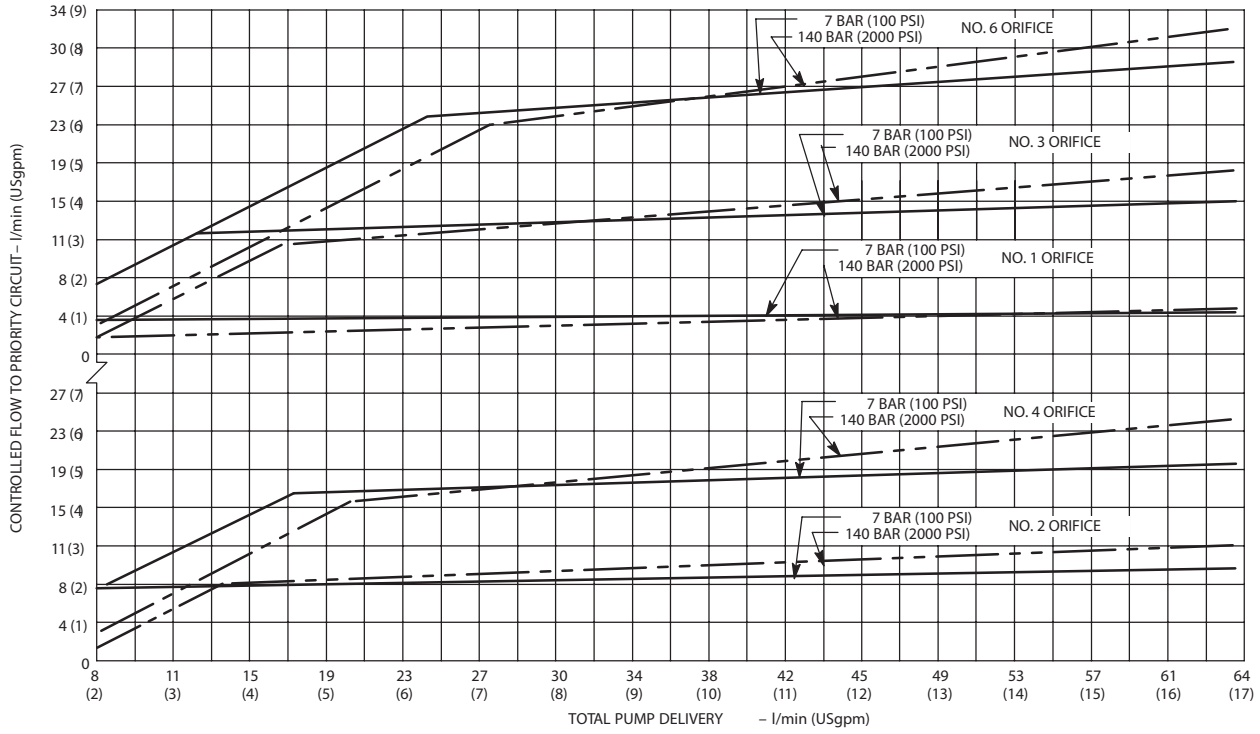

V20P Single Pumps

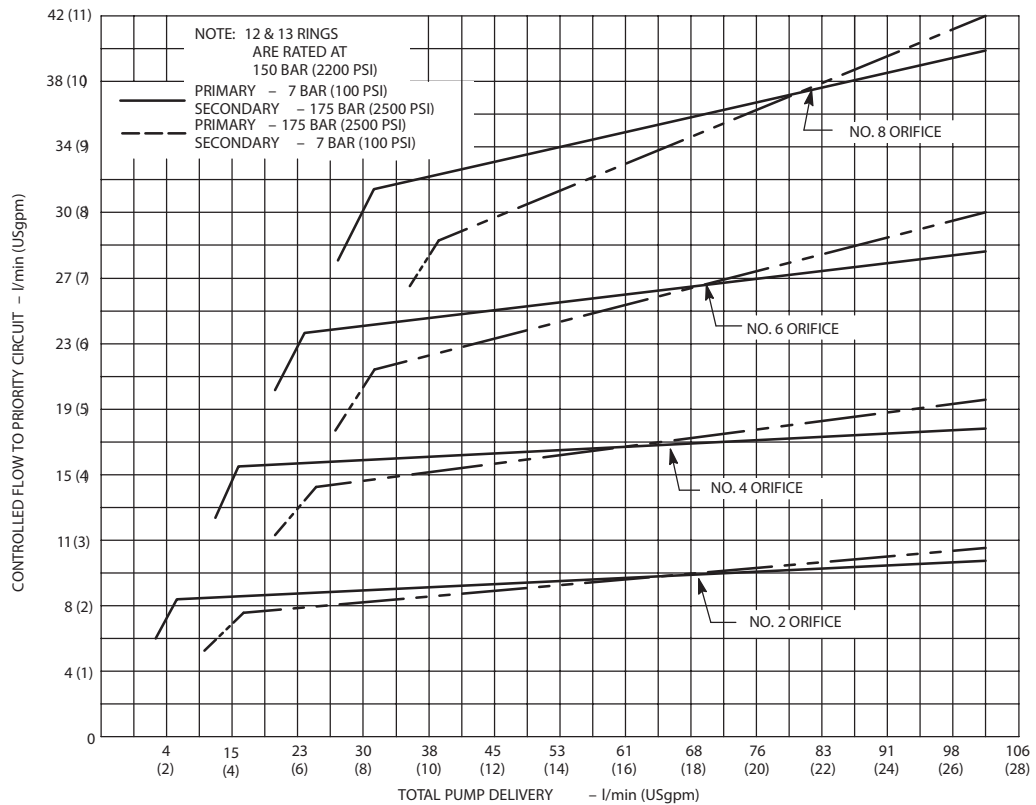

Typical Performance

Flow Control Models

V10F & V20F Single Pumps

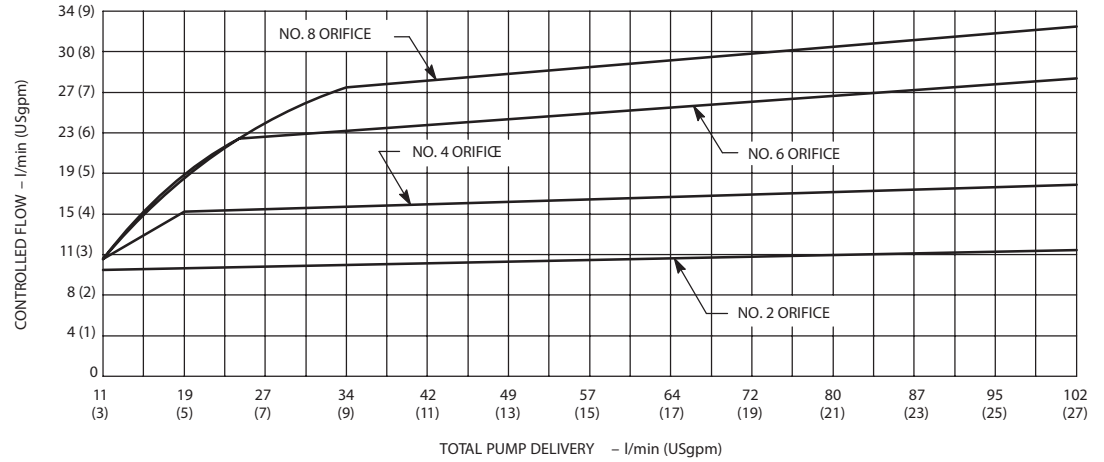

Speed Correction Curves

V10 & V20 Single Pumps

Maximum operating speeds shown on performance curves are for pumps operating at 0 psi inlet condition. To compute maximum operating speeds at other inlet conditions, use appropriate speed rating correction factor.

Example:

Max. speed @ 0 psi inlet 2700 r/min
 Correction factor @ 5 in. Hg $\times .93$
 Max. speed @ 5 in. Hg inlet 2511 r/min

Pump inlet suction should not exceed 5 in. Hg vacuum. Positive pressure on inlet should not exceed 0,7 bar (10 psi).

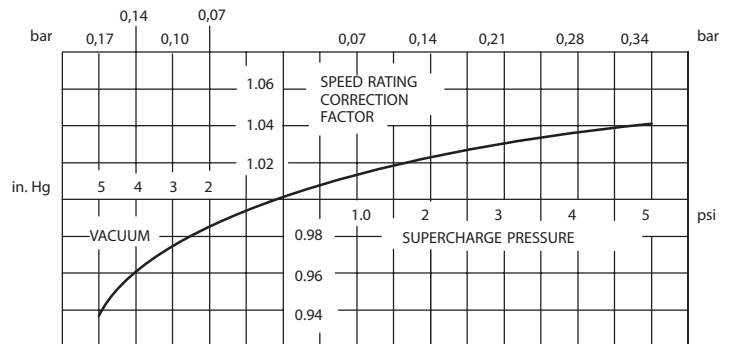

Double Pump Operating Specifications

Shaft end pump

Model Series	Delivery USgpm @ 120 0 r/min 7 bar (10 0 psi)	Displ. cm ³ /r (in ³ /r)	Max. r/min	Max. bar (psi)	Typical del. L/min (USgpm) @ max. speed & pressure	Typical input kW (hp) @ max. speed & pressure	Weight kg (lb.)
V2010,	6	19,5 (1.19)	3000	172 (2500)	54,9 (14.5)	18,3 (24.5)	13,6 (30)
V2010F	7	22,8 (1.39)	3000	172 (2500)	63,3 (16.7)	22,0 (29.5)	
&	8	26,6 (1.62)	2800	172 (2500)	67,1 (17.7)	24,2 (32.5)	
V2010P	9	29,7 (1.81)	2800	172 (2500)	75,0 (19.8)	26,5 (35.5)	
	11	36,4 (2.22)	2500	172 (2500)	86,8 (22.9)	28,0 (37.5)	
	12	39,0 (2.38)	2400	152 (2200)	87,2 (23.0)	26,8 (36.0)	
	13	42,5 (2.59)	2400	152 (2200)	98,1 (25.9)	29,1 (39.0)	
V2020,	6	19,5 (1.19)	3000	172 (2500)	54,9 (14.5)	19,4 (26.0)	15,9 (35)
V2020F	7	22,8 (1.39)	3000	172 (2500)	63,3 (16.7)	22,0 (29.5)	
&	8	26,6 (1.62)	2800	172 (2500)	67,1 (17.7)	24,2 (32.5)	
V2020P	9	29,7 (1.81)	2800	172 (2500)	75,0 (19.8)	26,5 (35.5)	
	11	36,4 (2.22)	2500	172 (2500)	86,8 (22.9)	28,0 (37.5)	
	12	39,0 (2.38)	2400	152 (2200)	87,2 (23.0)	26,8 (36.0)	
	13	42,5 (2.59)	2400	152 (2200)	98,1 (25.9)	29,1 (39.0)	

Cover end pump

V2010,	1	3,3 (.20)	3000	172 (2500)	7,6 (2.0)	3,4 (4.5)	13,6 (30)
V2010F	2	6,6 (.40)	3000	172 (2500)	17,8 (4.7)	6,7 (9.0)	
&	3	9,8 (.60)	3000	172 (2500)	26,5 (7.0)	10,0 (13.4)	
V2010P	4	13,1 (.80)	3000	172 (2500)	36,0 (9.5)	13,4 (18.0)	
	5	16,4 (1.00)	3000	172 (2500)	45,4 (12.0)	16,0 (21.5)	
	6	19,5 (1.19)	3000	152 (2200)	55,3 (14.6)	18,3 (24.5)	
	7	22,8 (1.39)	2800	138 (2000)	60,6 (16.0)	17,9 (24.0)	
V2020,	6	19,5 (1.19)	3000	172 (2500)	54,9 (14.5)	19,4 (26.0)	15,9 (35)
V2020F	7	22,8 (1.39)	3000	172 (2500)	62,5 (16.5)	22,4 (30.0)	
&	8	26,5 (1.62)	2800	172 (2500)	66,2 (17.5)	24,2 (32.5)	
V2020P	9	29,7 (1.81)	2800	172 (2500)	75,7 (20.0)	26,8 (36.0)	
	11	36,4 (2.22)	2500	172 (2500)	87,1 (23.0)	28,0 (37.5)	

NOTE: Review "Applying Vane Units" page 7, prior to selection of pump.

Model Codes

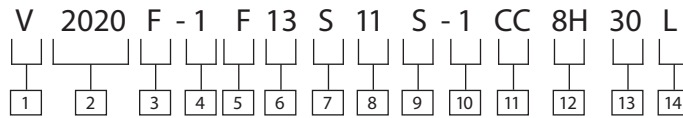

1 Vane pump

2 Series
V2010 or V2020

3 Integral valve options
(Omit if not required)
F – Flow control & relief
P – Priority valve & relief

4 Mounting
1 – 2-bolt flange (SAE “B” size pad)
6 – 2-bolt flange (SAE “A” size pad)

5 Inlet port connections
D – 4-bolt flange 2.00 dia. (V2020)
1.50 dia. (V2010)

6 Shaft end pump
SAE rated capacity – USgpm
(1200 rpm & 100 psi)
6 – 6 USgpm 11 – 11 USgpm
7 – 7 USgpm 12 – 12 USgpm
8 – 8 USgpm 13 – 13 USgpm
9 – 9 USgpm

7 No. 1 outlet port (shaft end)
S – 1.062 - 12 UN-2B thd.

8 Cover end pump
SAE rated capacity – USgpm
(1200 rpm & 100 psi)
6 – 6 USgpm
7 – 7 USgpm
8 – 8 USgpm
9 – 9 USgpm
1 – 11 USgpm
V2020

1 – 1 USgpm
2 – 2 USgpm
3 – 3 USgpm
4 – 4 USgpm
5 – 5 USgpm
6 – 6 USgpm
7 – 7 USgpm
V2010

9 No. 2 Outlet port (cover end)
(See table)

10 Shafts
1 – Straight keyed
3 – Threaded with Woodruff key
11 – Splined

11 Position of outlet
(Viewed from cover end of pump)
V2020
With no. 1 outlet opposite inlet
AA – No. 2 outlet opposite inlet
AB – No. 2 outlet 90 ° CCW from inlet
AC – No. 2 outlet in line with inlet
AD – No. 2 outlet 90 ° CW from inlet
With no. 1 outlet 90 ° CCW from inlet
BA – No. 2 outlet opposite inlet
BB – No. 2 outlet 90 ° CCW from inlet
BC – No. 2 outlet in line with inlet
BD – No. 2 outlet 90 ° CW from inlet
With no. 1 outlet inline with inlet
CA – No. 2 outlet opposite inlet
CB – No. 2 outlet 90 ° CCW from inlet
CC – No. 2 outlet in line with inlet
CD – No. 2 outlet 90 ° CW from inlet
With no. 1 outlet 90 ° CW from inlet
DA – No. 2 outlet opposite inlet
DB – No. 2 outlet 90 ° CCW from inlet
DC – No. 2 outlet in line with inlet
DD – No. 2 outlet 90 ° CW from inlet

V2010
With no. 1 outlet opposite inlet
AA – No. 2 outlet 135 ° CCW from inlet
AB – No. 2 outlet 45 ° CCW from inlet
AC – No. 2 outlet 45 ° CW from inlet
AD – No. 2 outlet 135 ° CW from inlet
With no. 1 outlet 90 ° CCW from inlet
BA – No. 2 outlet 135 ° CCW from inlet

No. 2 Outlet port

Code	Std. cover		Flow control cover		Priority valve cover		
	Pressure	Tank	Pressure	Tank	Primary outlet	Secondary outlet	Tank
K	-	-	-	-	9/16-18 St. thd. (V2010P)	3/4-16 St. thd. (V2010P)	9/16-18 St. thd. (V2010P)
P	-	-	3/4-16 St. thd. (V2010 & V2020F)	1/2" NPT thd. (V2010F & V2020F)	-	-	-
S	3/4"-16 St. thd. (V2010 only)	-	-	-	-	-	-
	1-1/16-12 St. thd. (V2020 only)	3/4-16 St. thd. (V2020F)	1-1/16-12 St. thd. (V2020F)	-	-	-	-
T	-	3/4-16 St. thd. (V2010F & V2020F)	3/4-16 St. thd. (V2010F & V2020F)	3/4-16 St. thd. (V2020P)	7/8-14 St. thd. (V2020P)	3/4-16 St. thd. (V2020P)	-

BB – No. 2 outlet 45 ° CCW from inlet
BC – No. 2 outlet 45 ° CW from inlet
BD – No. 2 outlet 135 ° CW from inlet
With no. 1 outlet in line with inlet
CA – No. 2 outlet 135 ° CCW from inlet
CB – No. 2 outlet 45 ° CCW from inlet
CC – No. 2 outlet 45 ° CW from inlet
CD – No. 2 outlet 135 ° CW from inlet
With no. 1 outlet 90 ° CW from inlet
DA – No. 2 outlet 135 ° CCW from inlet
DB – No. 2 outlet 45 ° CCW from inlet
DC – No. 2 outlet 45 ° CW from inlet
DD – No. 2 outlet 135 ° CW from inlet

12 Integral valves

Orifice No.	Relief valve setting	
Flow rate	bar (psi)	
l/min		
(USgpm)		
1 – 4 (1)	A – 17 (250)	G – 120 (1750)
2 – 8 (2)	B – 35 (500)	H – 140 (2000)
3 – 11 (3)	C – 52 (750)	J – 155 (2250)
4 – 15 (4)	D – 70 (1000)	K – 175 (2500)
6 – 22 (6)	E – 86 (1250)	
8 – 30 (8)	F – 100 (1500)	

13 Design
Subject to change. Installation dimensions remain the same for designs –10 thru –19 (V2010) and –30 thru –39 (V2020).

14 Shaft Rotation
(Viewed from shaft end of pump)
L – Left hand for counterclockwise
Omit for right hand.

Installation Dimensions

V2010 Series

Dimensions in millimeters (inches).

Shaft options shown on page 85.

Rated Delivery, gpm
@ 1200 rpm & 100 psi

Dimensions

Shaft end	Cover end	A	B	C
7,8 or 9	1, 2 or 3	213,1 (8.39)	189,2 (7.45)	113,3 (4.46)
7,8 or 9	4 or 5	219,5 (8.64)	195,6 (7.70)	113,3 (4.46)
7,8 or 9	6 or 7	224,5 (8.84)	200,7 (7.90)	113,3 (4.46)
11	1, 2 or 3	218,2 (8.59)	194,3 (7.65)	118,1 (4.65)
11	4 or 5	224,5 (8.84)	200,7 (7.90)	118,1 (4.65)
11	6 or 7	229,6 (9.04)	205,7 (8.10)	121,7 (4.79)
12 or 13	1, 2 or 3	221,7 (8.73)	197,9 (7.79)	121,7 (4.79)
12 or 13	4 or 5	227,8 (8.97)	204,0 (8.03)	121,7 (4.79)
12 or 13	6 or 7	232,9 (9.17)	209,0 (8.23)	121,7 (4.79)

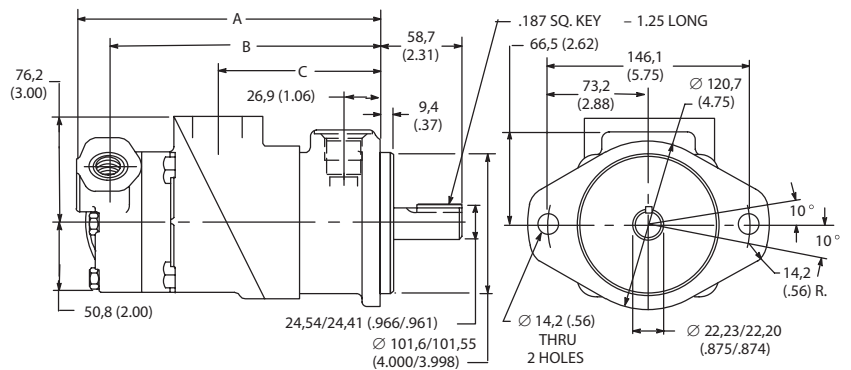
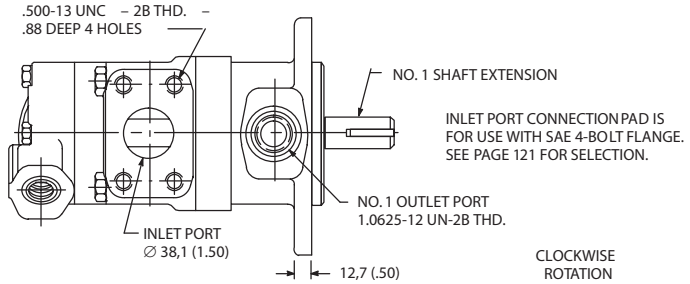
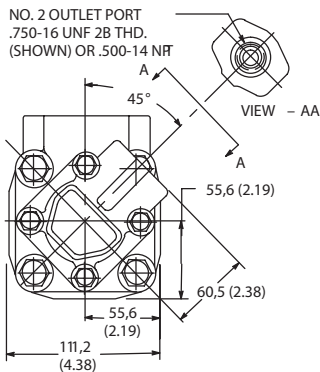

V2010F Series

Dimensions in millimeters (inches).

Shaft options shown on page 85.

Rated Delivery, gpm
@ 1200 rpm & 100 psi

Dimensions

Shaft end	Cover end	A	B	C
7,8 or 9	1, 2 or 3	226,1 (8.90)	206,8 (8.14)	113,3 (4.46)
7,8 or 9	4 or 5	232,4 (9.15)	213,1 (8.39)	113,3 (4.46)
7,8 or 9	6 or 7	237,5 (9.35)	218,2 (8.59)	113,3 (4.46)
11	1, 2 or 3	230,9 (9.09)	211,6 (8.33)	118,1 (4.65)
11	4 or 5	237,2 (9.34)	217,9 (8.58)	118,1 (4.65)
11	6 or 7	242,3 (9.54)	223,0 (8.78)	121,7 (4.79)
12 or 13	1, 2 or 3	234,4 (9.23)	215,1 (8.47)	121,7 (4.79)
12 or 13	4 or 5	240,8 (9.48)	221,5 (8.72)	121,7 (4.79)
12 or 13	6 or 7	245,9 (9.68)	226,6 (8.92)	121,7 (4.79)

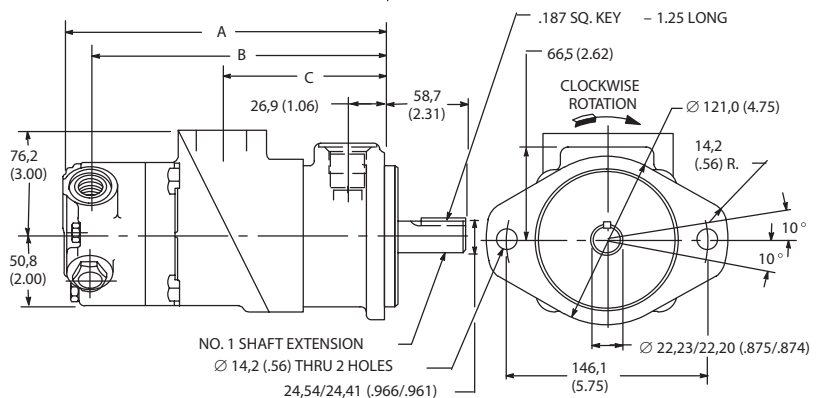
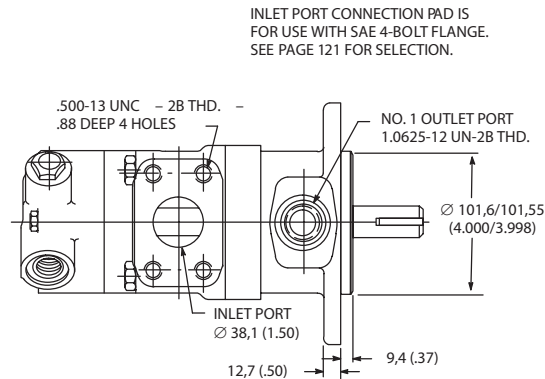
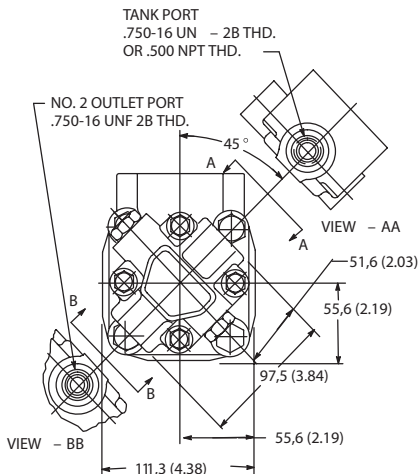

Installation Dimensions

V2010 Series

Dimensions in millimeters (inches).

Shaft options shown on page 85.

Rated Delivery, gpm
@ 1200 rpm & 100 psi

Dimensions

Shaft end	Cover end	A	B	C
7,8 or 9	1, 2 or 3	227,6 (8.96)	206,8 (8.14)	113,3 (4.46)
7,8 or 9	4 or 5	249,2 (9.21)	213,1 (8.39)	113,3 (4.46)
7,8 or 9	6 or 7	239,0 (9.41)	218,2 (8.59)	113,3 (4.46)
11	1, 2 or 3	232,4 (9.15)	211,6 (8.33)	118,1 (4.65)
11	4 or 5	238,8 (9.40)	217,9 (8.58)	118,1 (4.65)
11	6 or 7	243,8 (9.60)	223,0 (8.78)	121,7 (4.79)
12 or 13	1, 2 or 3	236,0 (9.29)	215,1 (8.47)	121,7 (4.79)
12 or 13	4 or 5	242,3 (9.54)	221,5 (8.72)	121,7 (4.79)
12 or 13	6 or 7	247,4 (9.74)	226,6 (8.92)	121,7 (4.79)

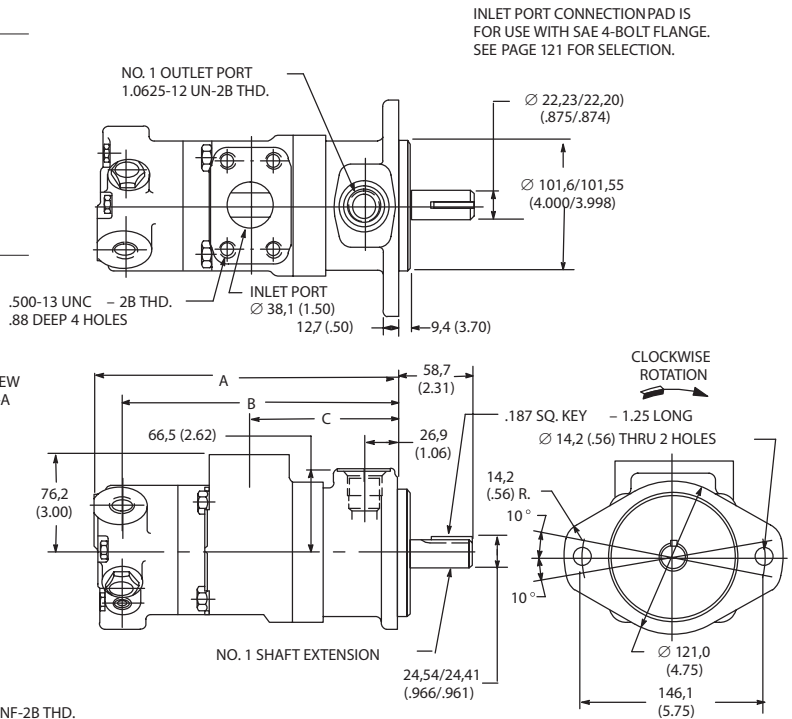
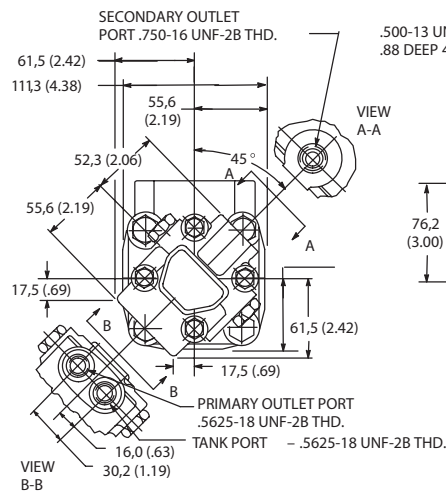

V2020 Series

Dimensions in millimeters (inches).

Shaft options shown on page 85.

Rated Delivery, gpm
@ 1200 rpm & 100 psi

Dimensions

Shaft end	Cover end	A	B	C
7,8 or 9	1, 2 or 3	227,6 (8.96)	206,8 (8.14)	113,3 (4.46)
7,8 or 9	4 or 5	249,2 (9.21)	213,1 (8.39)	113,3 (4.46)
7,8 or 9	6 or 7	239,0 (9.41)	218,2 (8.59)	113,3 (4.46)
11	1, 2 or 3	232,4 (9.15)	211,6 (8.33)	118,1 (4.65)
11	4 or 5	238,8 (9.40)	217,9 (8.58)	118,1 (4.65)
11	6 or 7	243,8 (9.60)	223,0 (8.78)	121,7 (4.79)
12 or 13	1, 2 or 3	236,0 (9.29)	215,1 (8.47)	121,7 (4.79)
12 or 13	4 or 5	242,3 (9.54)	221,5 (8.72)	121,7 (4.79)
12 or 13	6 or 7	247,4 (9.74)	226,6 (8.92)	121,7 (4.79)

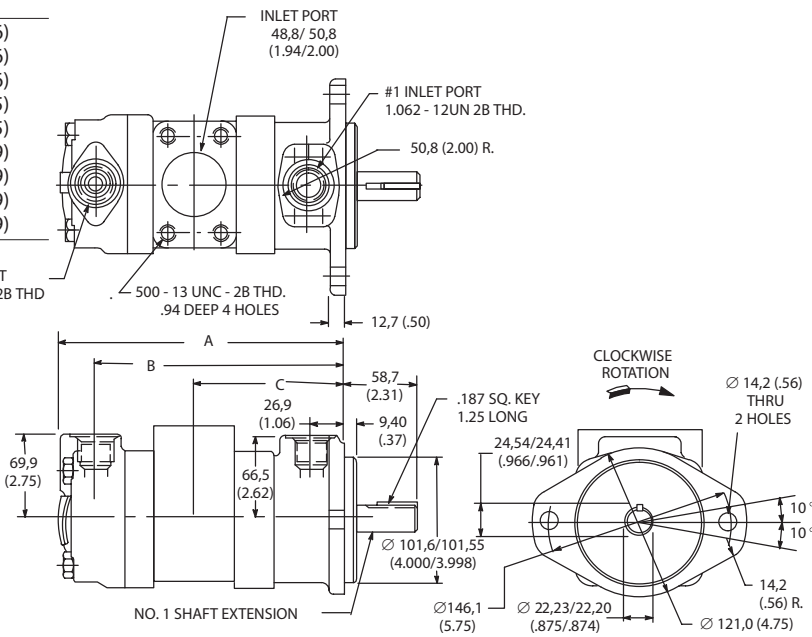
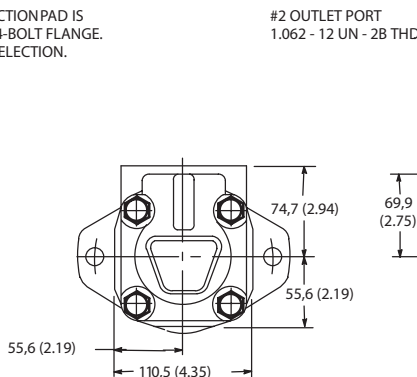

V2020F & V2020P Series

Dimensions in millimeters (inches).

Shaft options shown on page 85.

Rated Delivery, gpm
@ 1200 rpm & 100 psi

Dimensions

Shaft end	Cover end	A	B	C
7,8 or 9	6	235,0 (9.25)	211,1 (8.31)	114,0 (4.49)
7,8 or 9	7, 8 or 9	241,3 (9.50)	217,4 (8.56)	114,0 (4.49)
11	6	240,0 (9.45)	216,2 (8.51)	119,1 (4.69)
11	7, 8 or 9	246,4 (9.70)	222,5 (8.76)	119,1 (4.69)
11	11	251,2 (9.89)	227,3 (8.95)	119,1 (4.69)
12 or 13	6	243,6 (9.59)	219,7 (8.65)	122,4 (4.82)
12 or 13	7, 8 or 9	249,7 (9.83)	225,8 (8.89)	122,4 (4.82)
12 or 13	11	254,8 (10.03)	230,9 (9.09)	122,4 (4.82)

INLET PORT CONNECTION PAD IS
FOR USE WITH SAE 4-BOLT FLANGE.
SEE PAGE 121 FOR SELECTION.

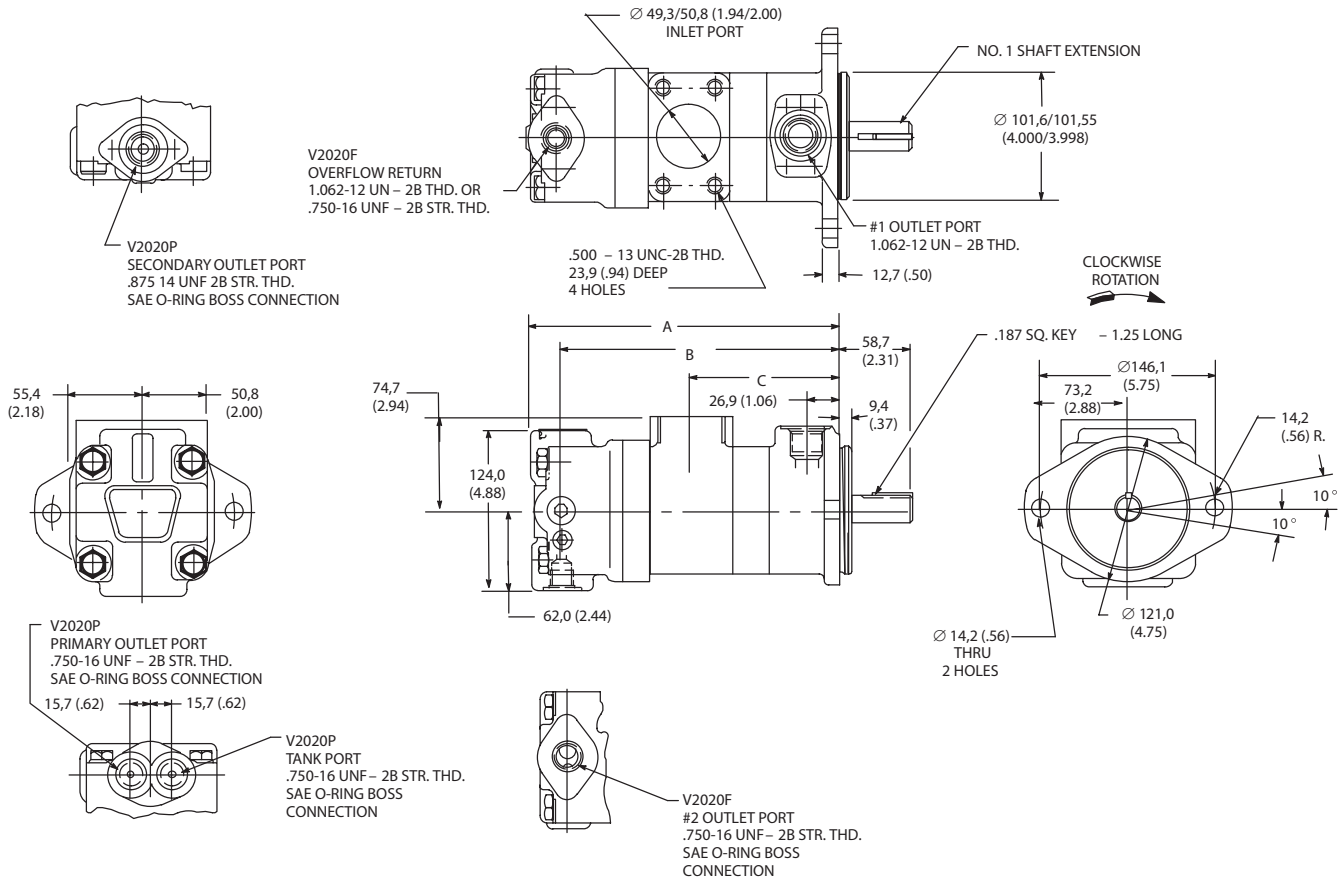

Optional Shafts

V2010 & V2020

Dimensions in millimeters (inches).

Note: No. 1 shaft is shown on pages 82 thru 84.

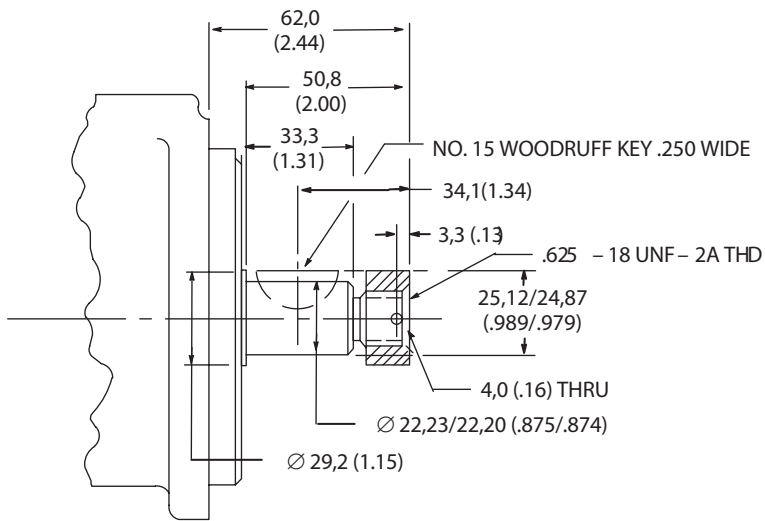

No. 3 shaft extension

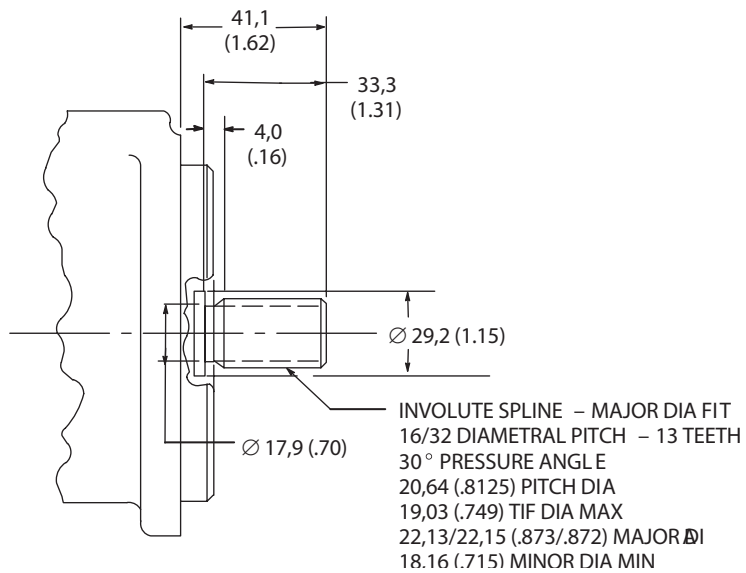

Typical Performance

Shaft-end Pumps
V2010 & V2020 Double Pumps

Performance Constants:
Oil temp. 49° C (120° F), viscosity 32 cSt (150 SSU) @ 38° C
(100° F), inlet pressure zero

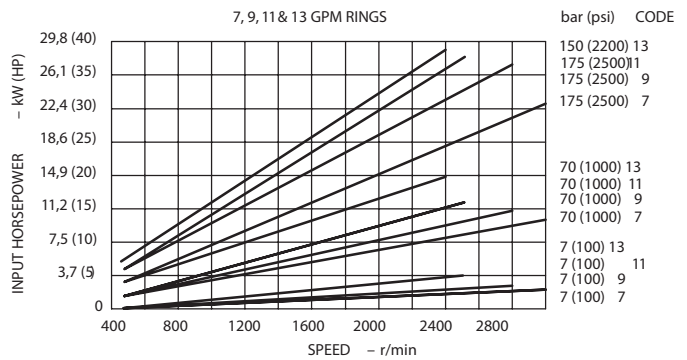
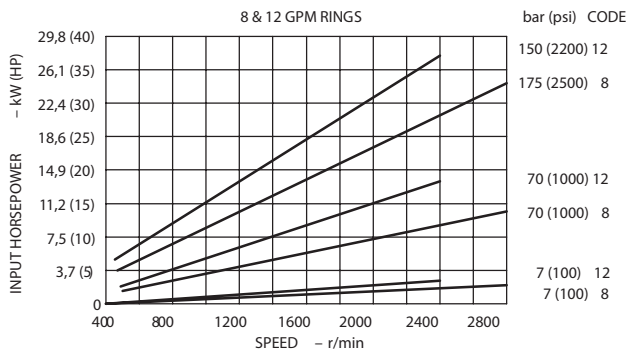
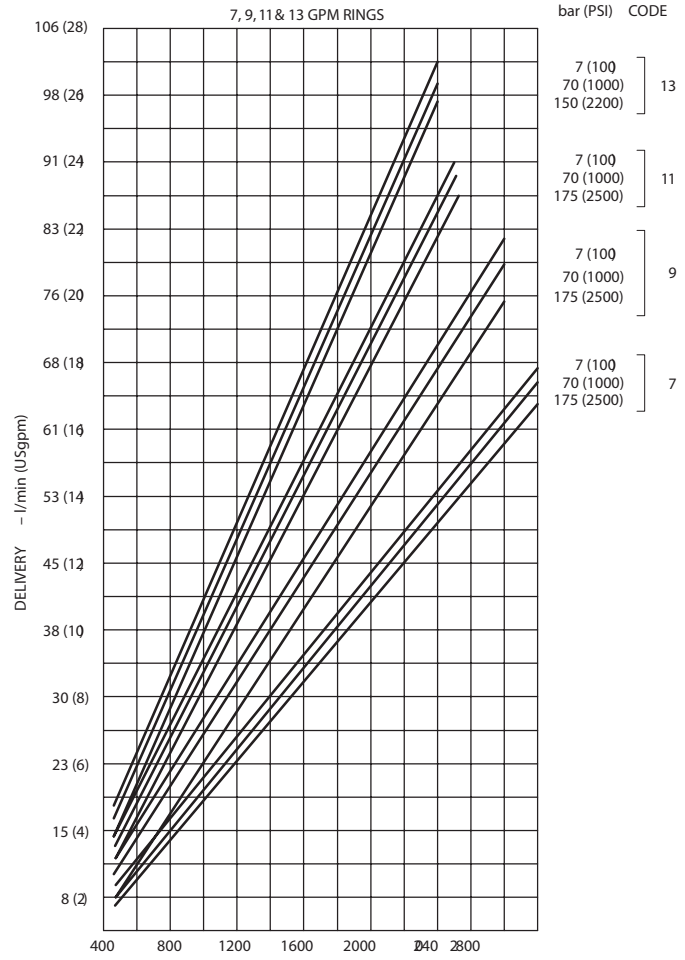
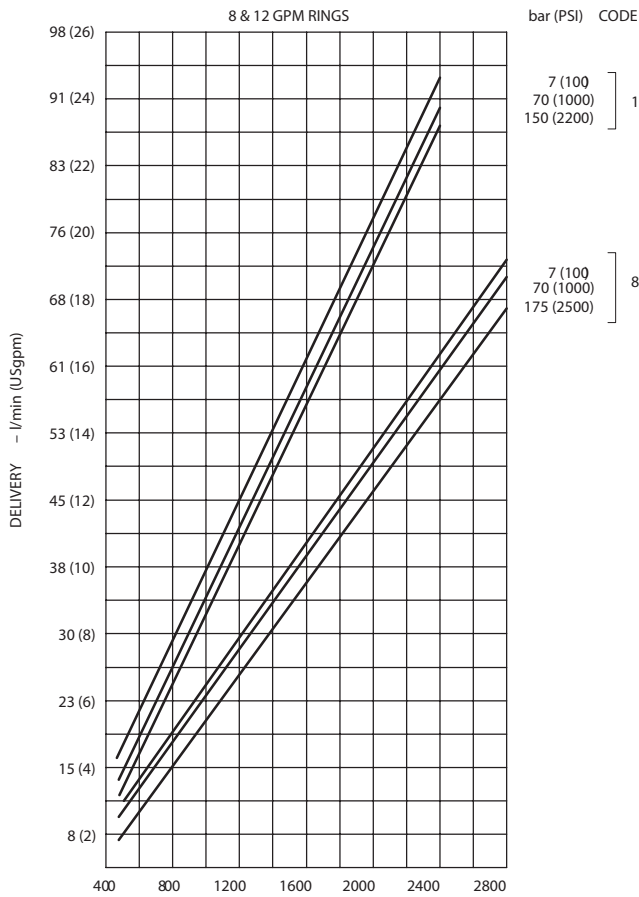

Typical Performance

Cover-end Pumps
V2010 Double Pumps

Performance Constants:
Oil temp. 49° C (120° F), viscosity 32 cSt (150 SSU) @ 38° C (100° F), inlet pressure zero

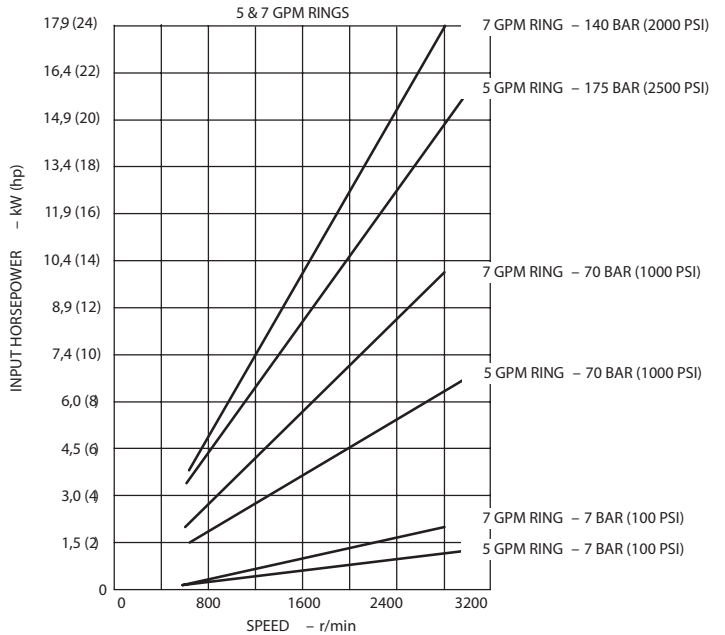
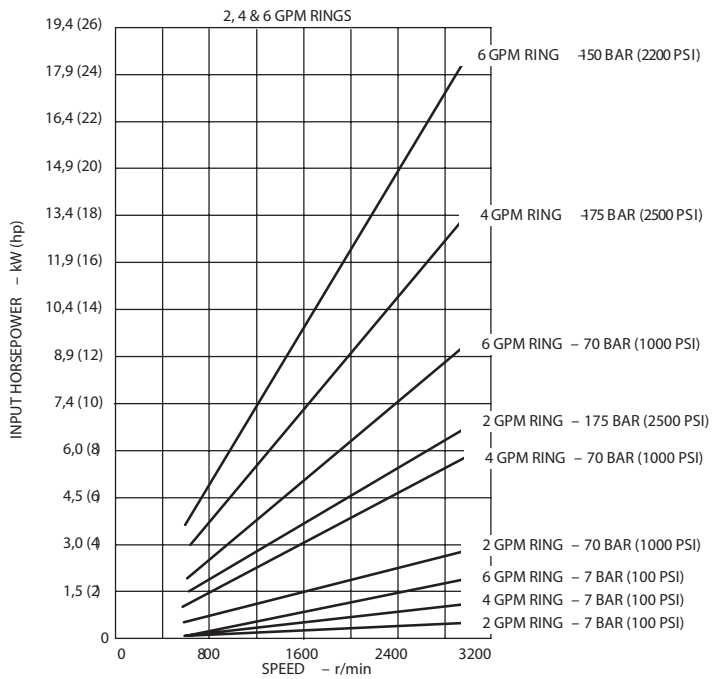
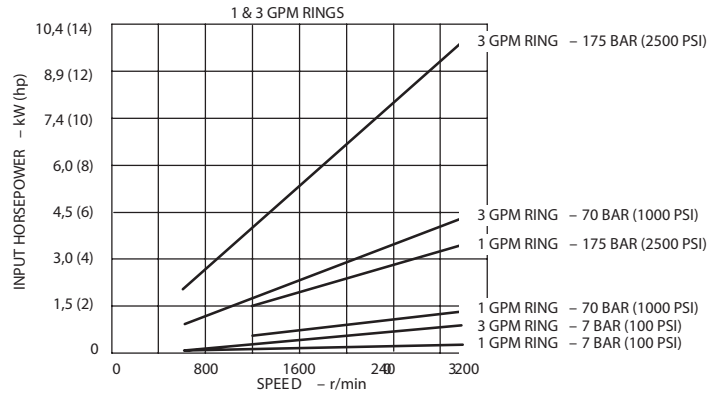
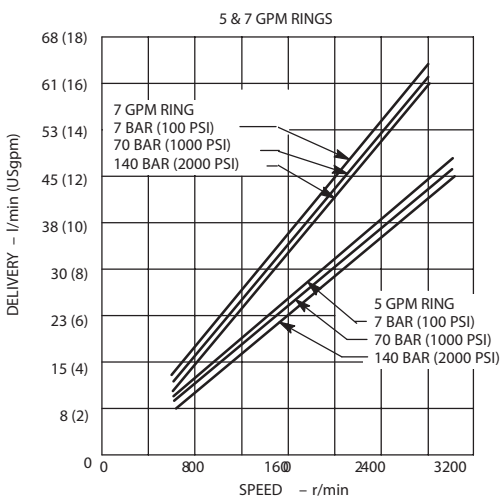
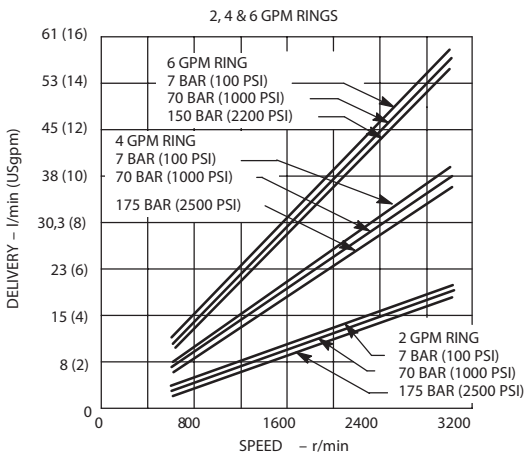
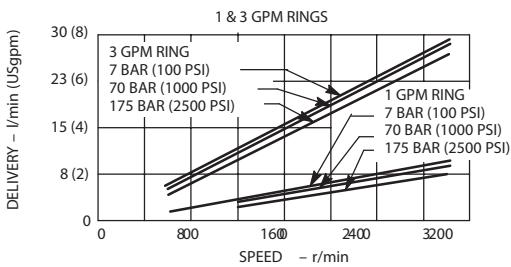

Cover-end Pumps V2020 Double Pumps

Performance Constants:

Oil temp. 49° C (120° F), viscosity 32 cSt (150 SSU) @ 38° C (100° F), inlet pressure zero

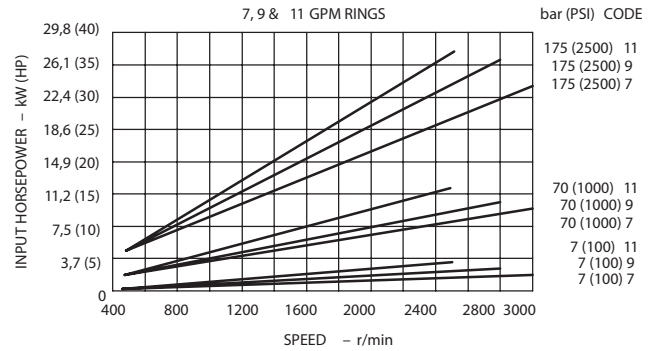
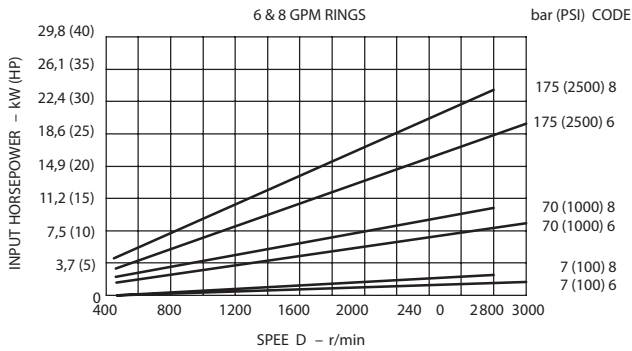
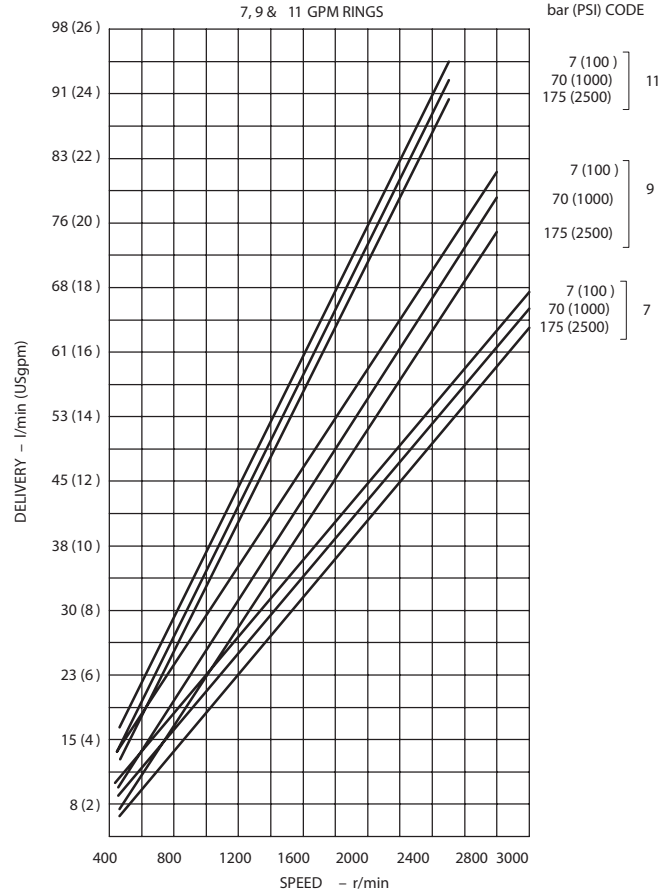
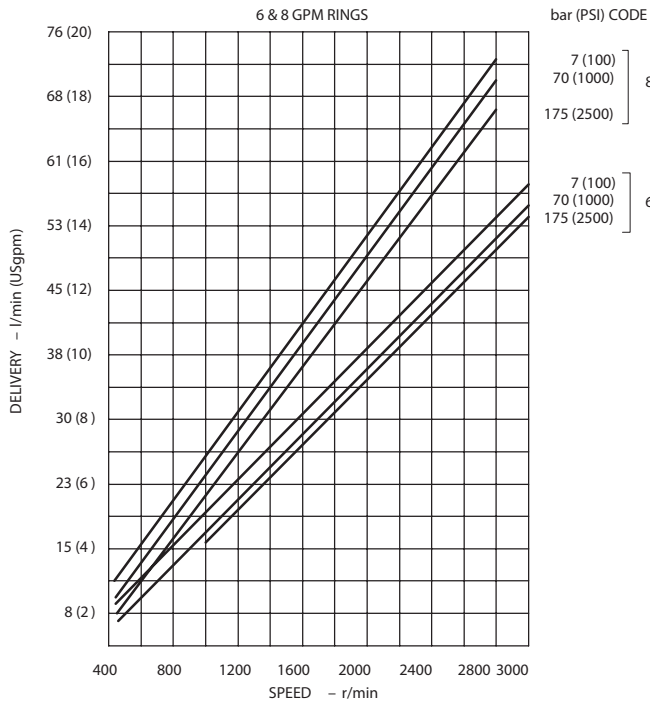

Typical Performance

Priority Valve Models

V2010P Double Pumps

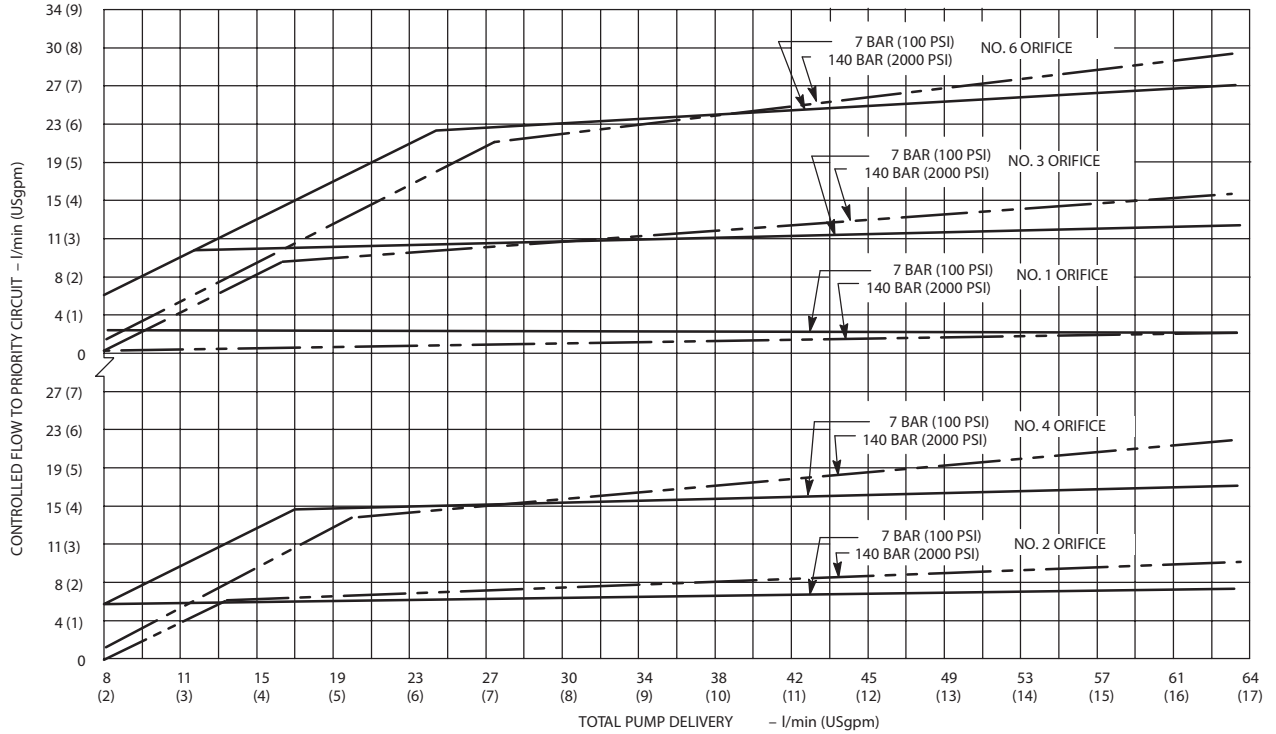

V2020P Double Pumps

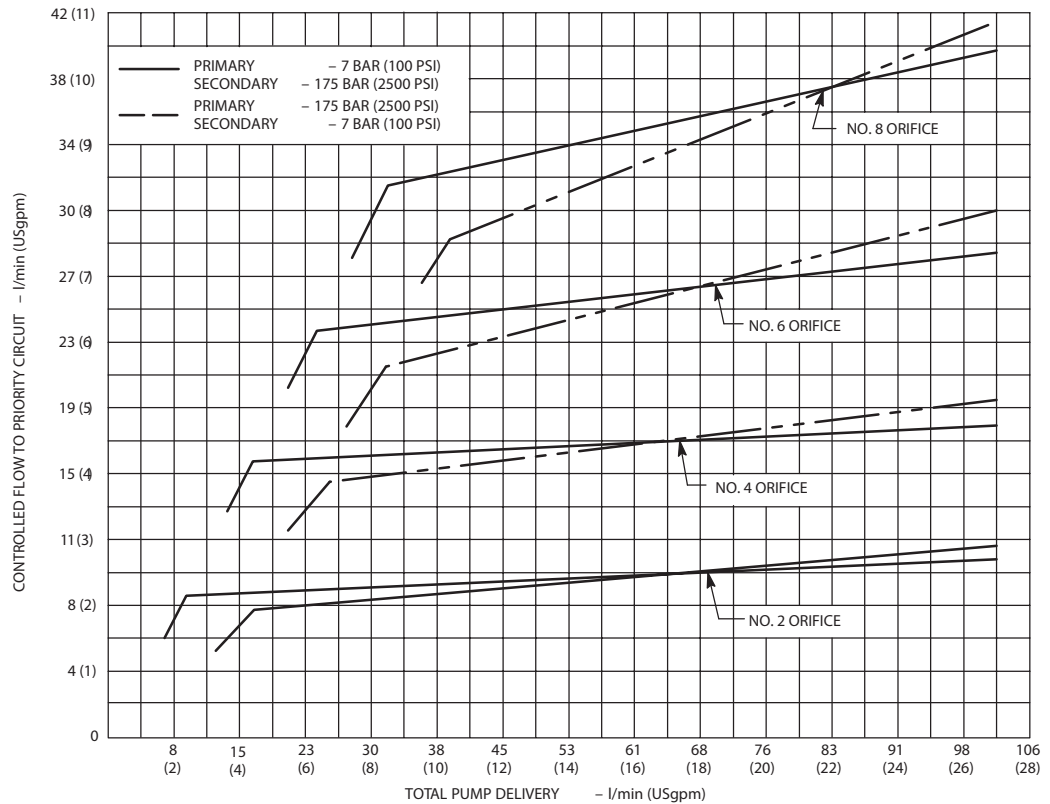

Flow Control Models

V2010F & V2020F Double Pumps

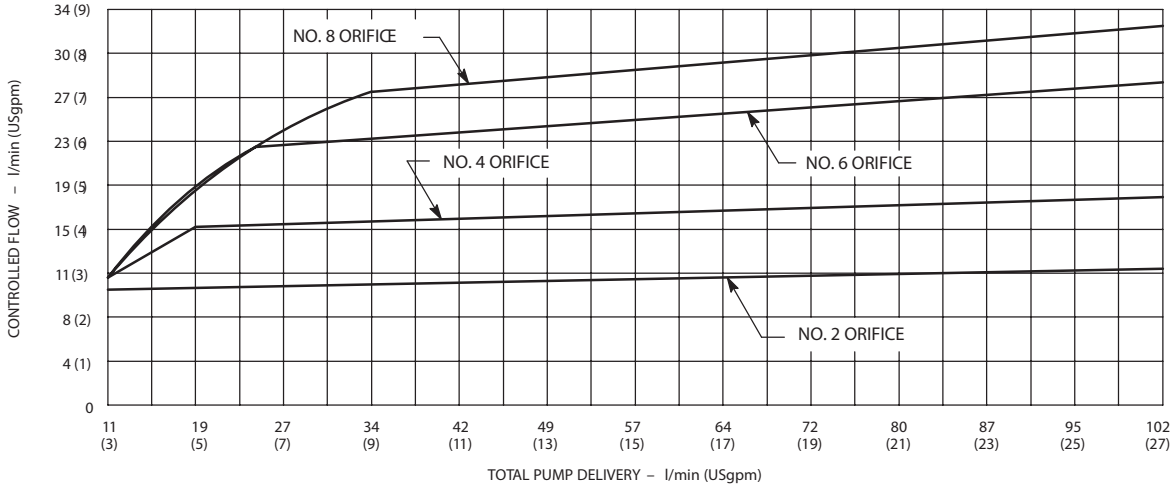

Speed Correction Curve

V2010 & V2020 Double Pumps

Maximum operating speeds shown on performance curves are for pumps operating at 0 psi inlet conditions. To compute maximum operating speeds at other inlet conditions, use appropriate speed rating corrections factors shown on the curve on the right.

Example:

Max. speed @ 0 psi inlet 2700 r/min
 Correction factor @ 5 in. Hg x .93
 Max. speed @ 5 in. Hg inlet 2511 r/min

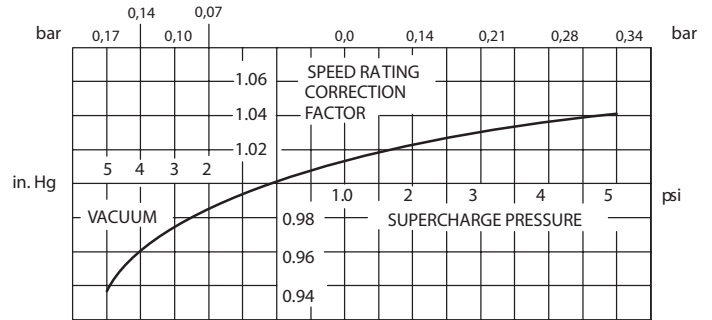

Pump inlet suction should not exceed 5 in. Hg vacuum. Positive pressure on inlet should not exceed 0,7 bar (10 psi)

VTM42 Power Steering Pumps

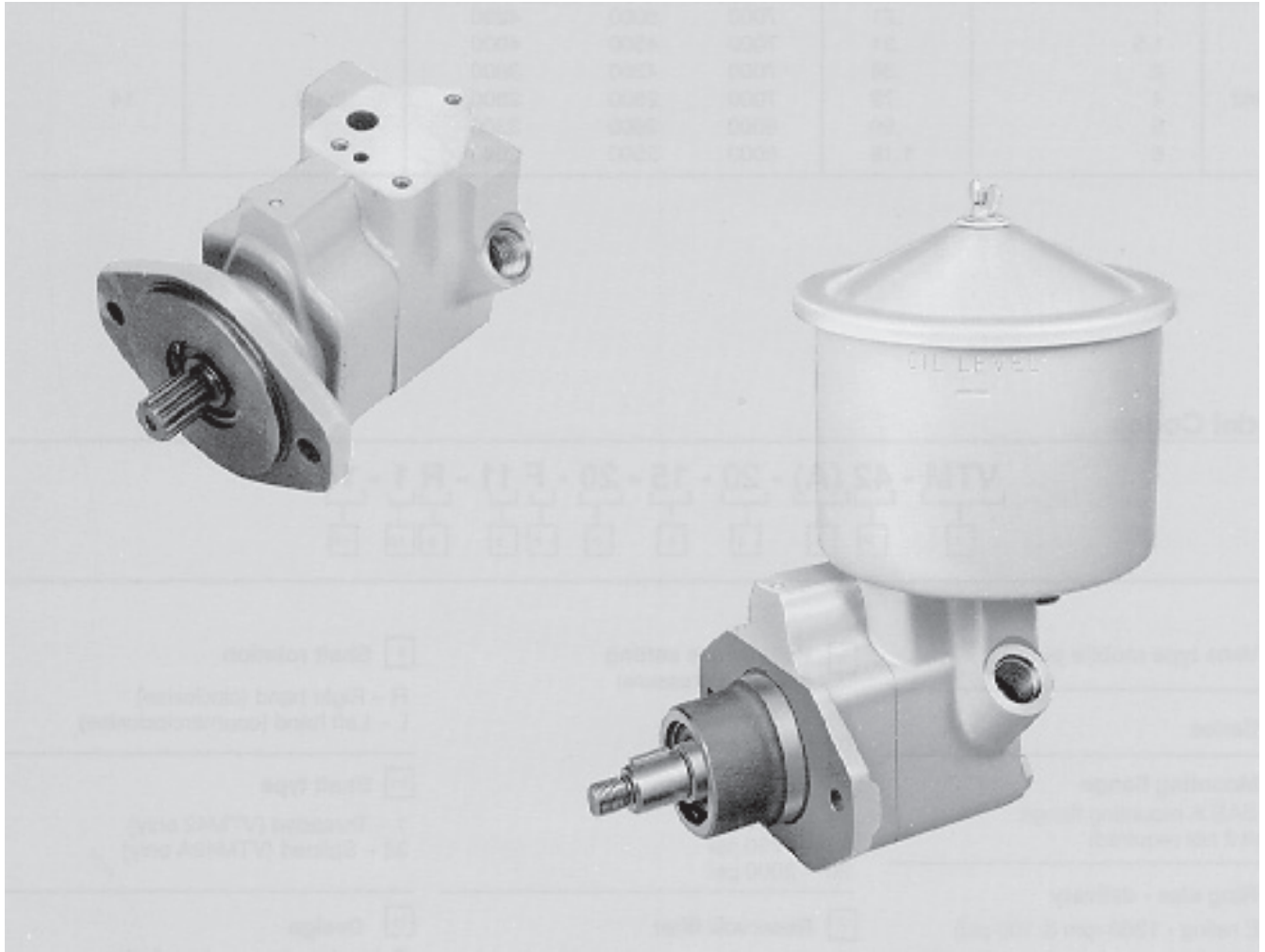

High Efficiency

Optimum running clearances and hydraulic balance provide sustained high efficiency throughout pump life.

Hydraulic Balance

Danfoss' design eliminates pressure-induced bearing loads to provide longer life and reduced maintenance.

Integral Valves

Flow control and relief eliminate the need for separate valves. Danfoss pumps supply, in one package, a complete power source for steering.

Operating Specifications

Model Series	Delivery USgpm		Displ. cm ³ /r (in ³ /r)	Maximum speed -r/min			Maximum pressure bar (psi)	Approx. weight kg (lbs.)
	@ 1200 r/min	@ 7 bar (100 psi)		@ 7 bar (100 psi)	@ 10 bar (150 psi)	@ 140 bar (200 psi)		
VTM42	1		3,4 (.21)	7000	5000	4250	140 (2000)	6,4 (14)
	1.5		5,1 (.31)	7000	4500	4000		
	2		6,2(.38)	7000	4200	3800		
	4		12,9 (.79)	7000	2800	2800		
	5		15,7 (.96)	6000	2600	2300		
	6		19,3 (1.18)	5000	2500	2000		

Model Codes

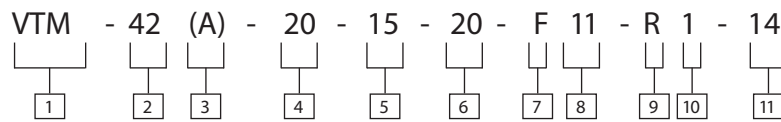

1 Vane type mobile pump

2 Series

3 Mounting flange

A – SAE A mounting flange
(Omit if not required)

4 Ring size - delivery
(SAE rating - 1200 rpm & 7 bar (100 psi))

10 – 1.0 USgpm	40 – 4.0 USgpm
15 – 1.5 USgpm	50 – 5.0 USgpm
20 – 2.0 USgpm	60 – 6.0 USgpm

5 Controlled flow rate
(at 1500 rpm & 7 bar (100 psi))

15 – 6 L/min (1.5 USgpm)
 20 – 8 L/min (2 USgpm)
 25 – 9,5 L/min (2.5 USgpm)
 30 – 11 L/min (3 USgpm)
 35 – 13 L/min (3.5 USgpm)
 40 – 15 L/min (4 USgpm)
 45 – 17 L/min (4.5 USgpm)
 50 – 19 L/min (5 USgpm)
 55 – 21 L/min (5.5 USgpm)
 60 – 23 L/min (6 USgpm)
 65 – 25 L/min (6.5 USgpm)
 70 – 26,5 L/min (7 USgpm)
 75 – 28 L/min (7.5 USgpm)

6 Relief valve setting
(cracking pressure)

05 – 35 bar (500 psi)
 07 – 52 bar (750 psi)
 10 – 70 bar (1000 psi)
 12 – 86 bar (1250 psi)
 15 – 100 bar (1500 psi)
 17 – 120 bar (1750 psi)
 20 – 140 bar (2000 psi)

7 Reservoir filter

F – Filter instead of standard baffle.
 Omit if not required.

8 Reservoir or manifold

07 – 1147 mL (70 in³) reservoir
 (Omit for VTM42A)
 11 – 1884 mL (115 in³) reservoir
 (Omit for VTM42A)
 MA – Manifold without bypass tube
 MB – Manifold with bypass tube
 MD – Manifold with 90° tank connection
 ME – Cast manifold without bypass tube
 MF – Cast manifold with bypass tube
 NO – None (shipping closure only)

9 Shaft rotation

R – Right hand (clockwise)
 L – Left hand (counterclockwise)

10 Shaft type

1 – Threaded (VTM42 only)
 38 – Splined (VTM42A only)

11 Design

Subject to change. Installation dimensions remain the same for designs –10 through –19.

VTM42A power steering pumps without manifold

Dimensions in millimeters (inches)

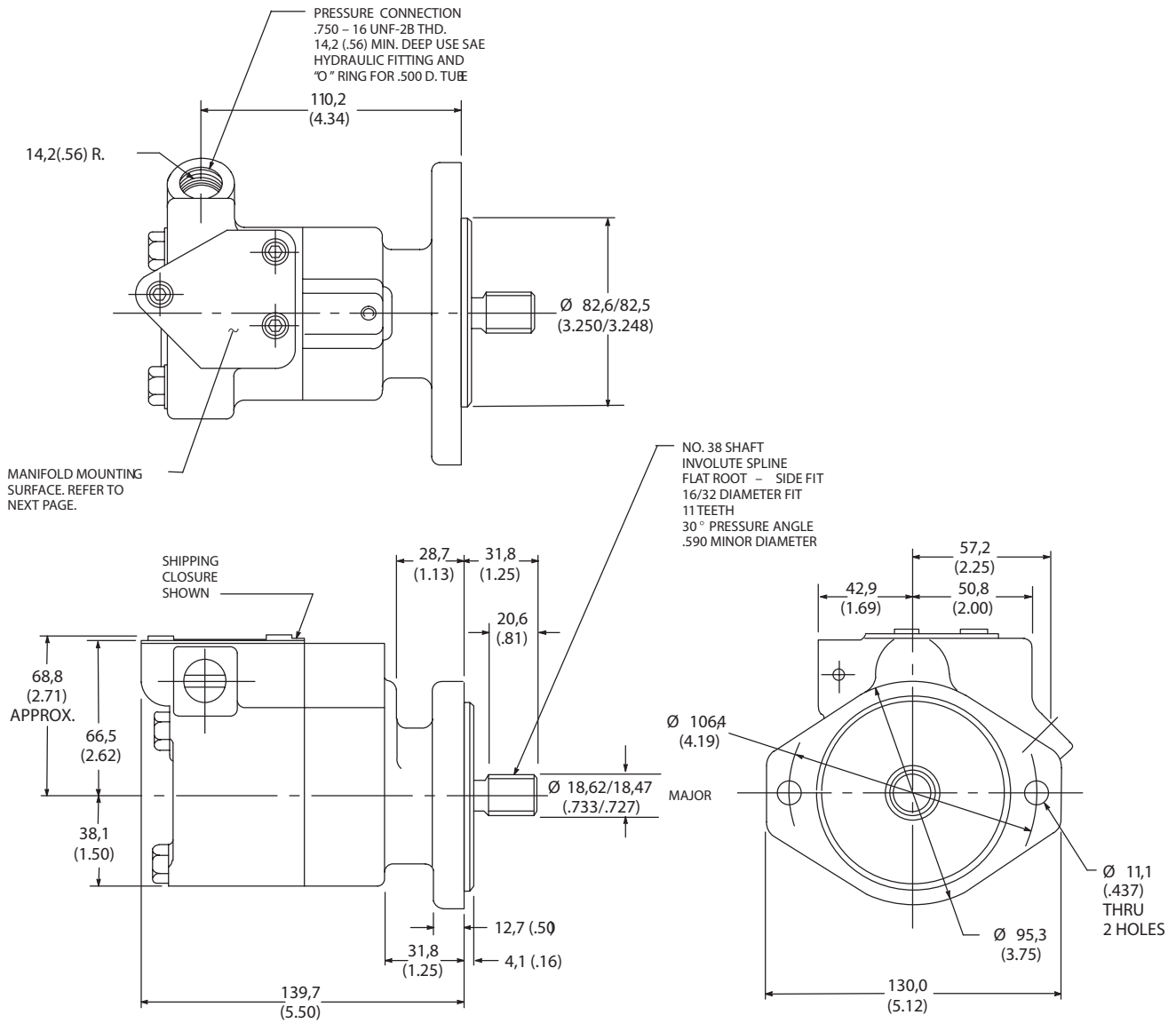

Installation Dimensions

Manifolds for power steering pumps

Dimensions in millimeters (inches)

"M A" MANIFOLD

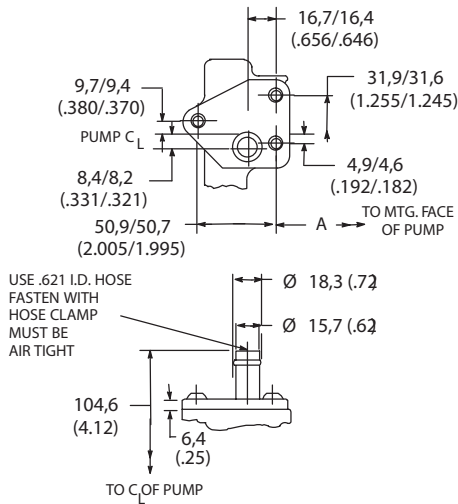

"M D" MANIFOLD

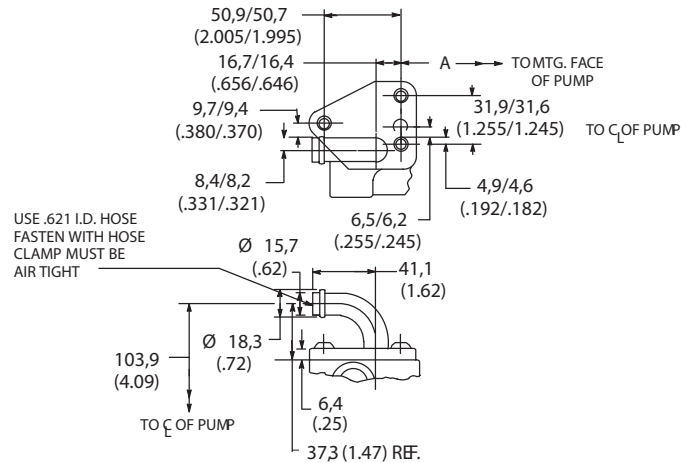

"MF" MANIFOLD

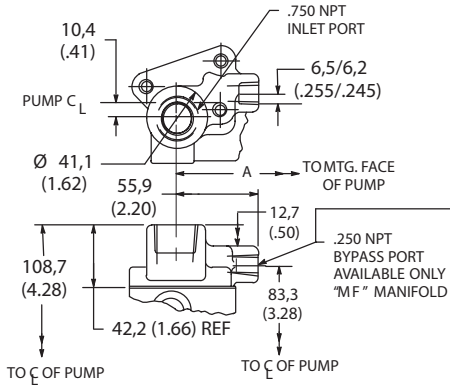

THIS TANK BYPASS CONN. IS REQUIRED FOR INSTALLATIONS WHICH OPERATE AT PUMP RELIEF VALVE PRESSURES FOR PERIODS EXCEEDING 15 SECONDS. CONNECTION MUST BE MADE BELOW OIL LEVEL IN RESERVOIR.

"ME" MANIFOLD

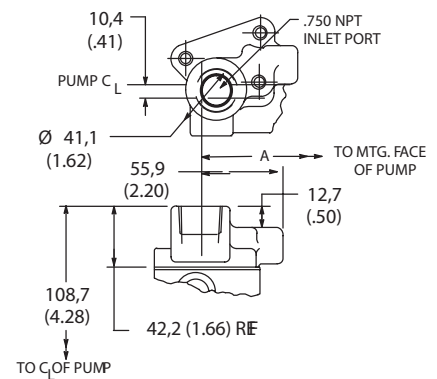

"M B" MANIFOLD

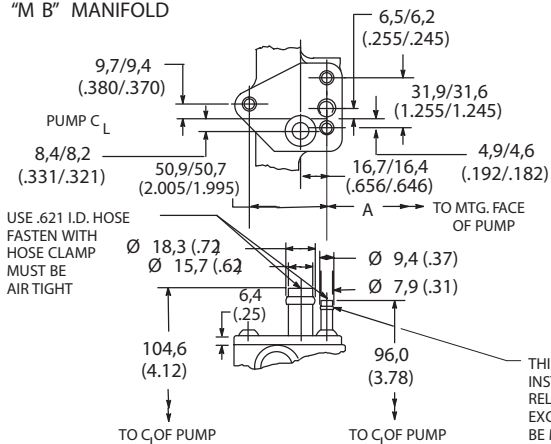

THIS TANK BYPASS CONN. IS REQUIRED FOR INSTALLATIONS WHICH OPERATE AT PUMP RELIEF VALVE PRESSURES FOR PERIODS EXCEEDING 15 SECONDS. CONNECTION MUST BE MADE BELOW OIL LEVEL IN RESERVOIR.

Manifold Code	Dimension A	
	VTM42	VTM42A
MA		
MB	47,0	78,7
MD	(1.85)	(3.10)
ME	75,9	107,7
MF	(2.99)	(4.24)

Typical Performance

VTM42(A)
power steering pumps

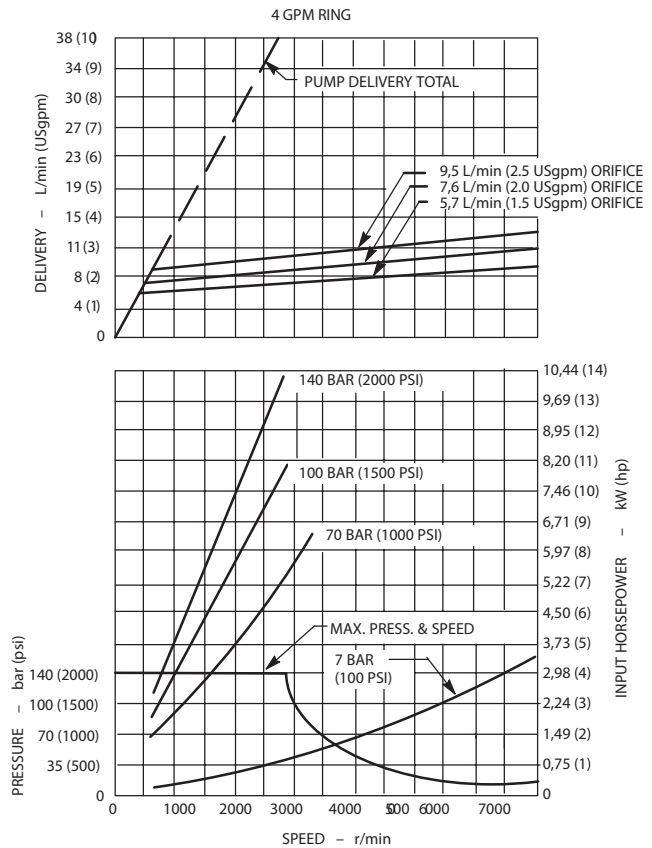
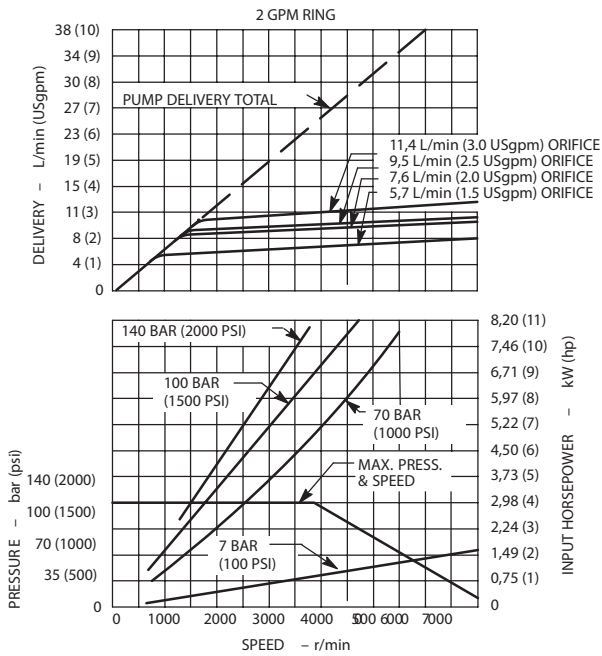
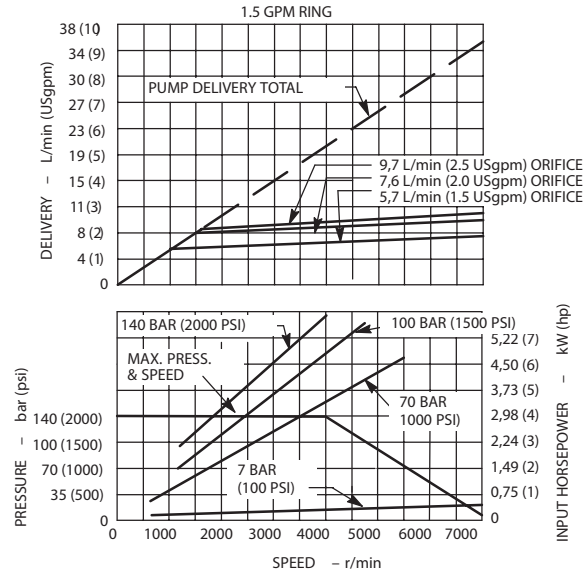
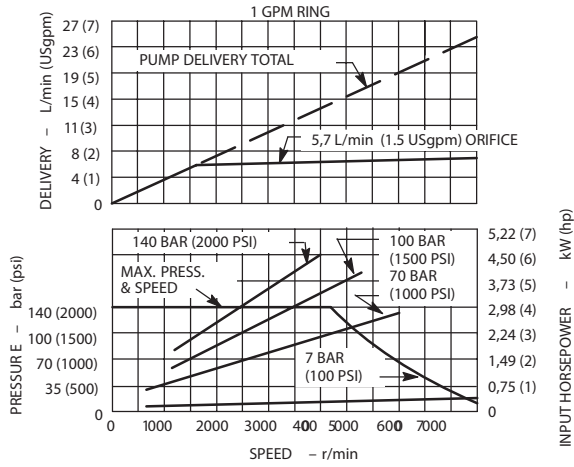

Typical Performance

VTM42(A)
Power Steering Pumps

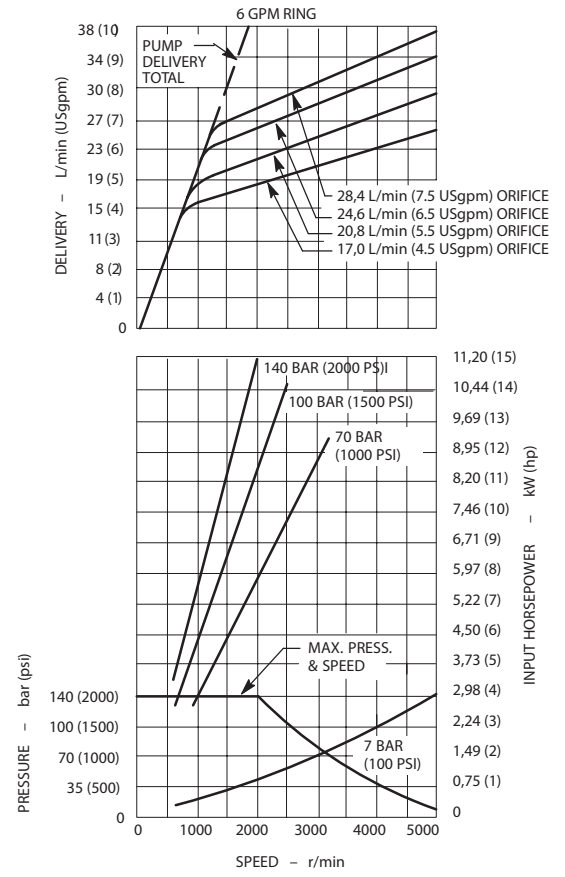
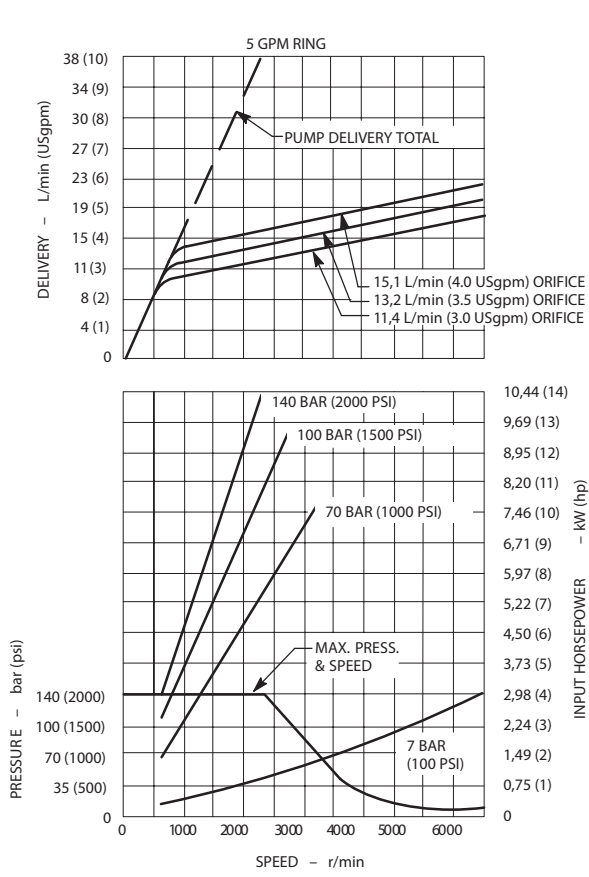

Vane Motors – 21,6 to 37,5 cm³/r (1.32 to 2.29 in³/r)

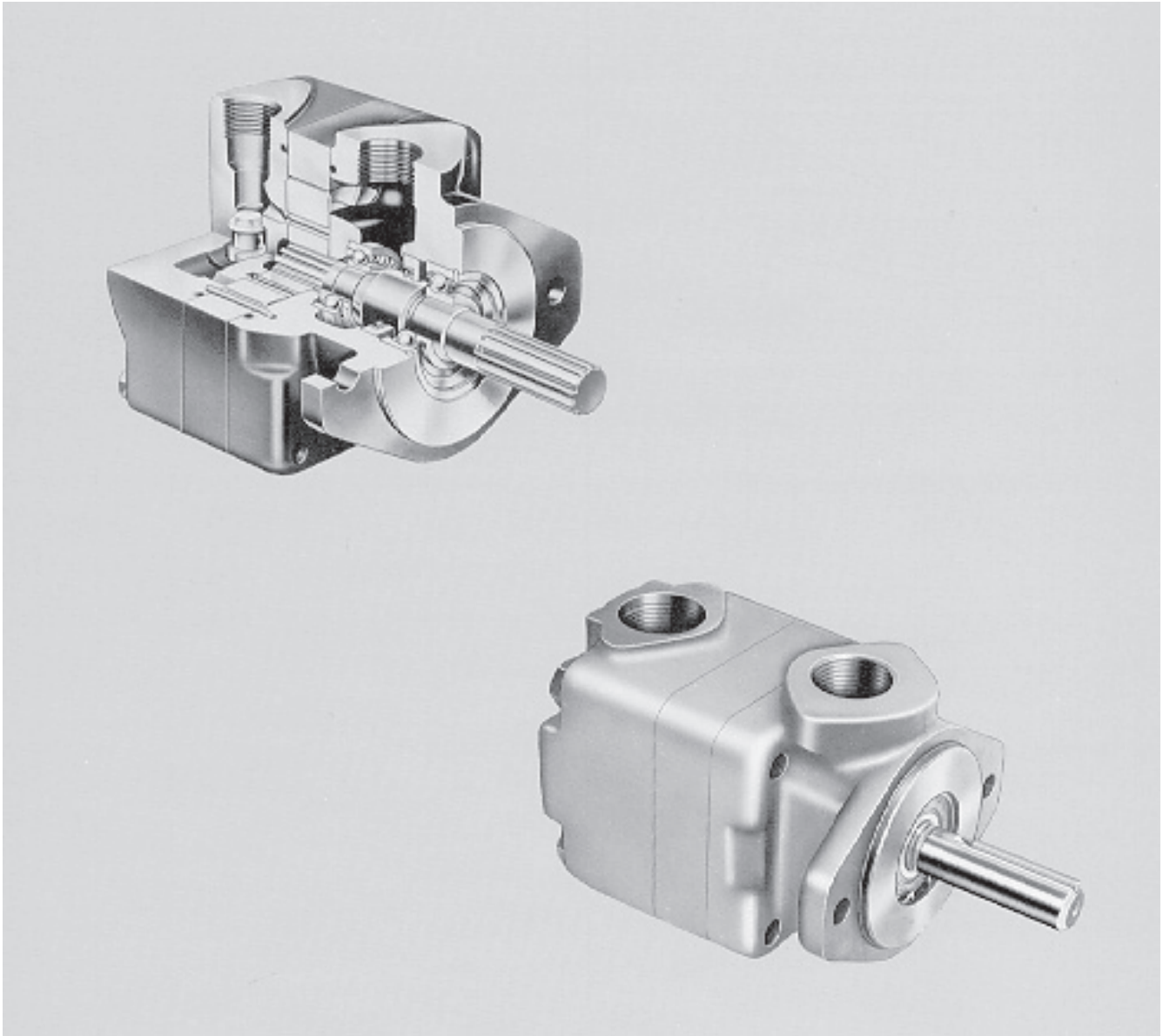

Characteristics

An economical, efficient and compact means of applying variable speed, rotary hydraulic power, these motors have variable horsepower (constant torque) characteristics. They can be stalled under load without damage when protected by a relief valve.

Hydraulic Balance

Two internal inlet chambers are diametrically opposed as are two outlet chambers. This construction eliminates bearing loads resulting from pressure, a major cause of wear in designs without this feature.

Efficiency

Optimum running clearances and hydraulic balance assure sustained high efficiency over the life of the motor.

Smooth Operation

Inertia of rotating parts is low ... parts are symmetrical, providing dynamic balance and freedom from vibration.

Operating Specifications

Model series	Torque Nm/6,9 bar (lb. in./100 psi)	Displ. cm ³ /r (in ³ /r)	Maximum torque Nm (lb. in.) @ max. pressure	Maximum speeds & pressures	Approx. weight lbs.
M2U	2,0 (18)	21,6 (1.32)	38,4 (340)	2800 r/min @ 138 bar (2000 psi)	7,7 (17)
	2,8 (25)	25,4 (1.55)	46,3 (410)	2500 r/min @ 138 bar (2000 psi)	
	4,0 (35)	37,5 (2.29)	67,8 (600)	2000 r/min @ 138 bar (2000 psi)	
M2-210	2,8 (25)	24,7 (1.51)	46,3 (410)	2200 r/min @ 138 bar (2000 psi)	9,5 (21)
	4,0 (35)	35,4 (2.16)	56,5 (500)	1800 r/min @ 121 bar (1750 psi)	

Model Codes

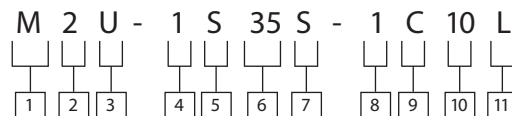

- 1** Vane motor
- 2** Series
- 3** Uni-directional rotation
- 4** Mounting
1 – 2-bolt flange
- 5** Inlet port
S – 1-5/16 – 12 st. thd.
- 6** Ring size – torque
(lb. in./100 psi)
18, 25 and 35
- 7** Outlet port
S – 1-5/16 – 12 st. thd.
- 8** Shaft type
1 – Straight keyed
3 – Threaded
11 – Splined
- 9** Outlet position
(Viewing cover end)
A – Outlet port opposite inlet
C – Port connections inline
- 10** Design
Subject to change. Installation dimensions remain the same for designs –10 through –19.
- 11** Rotation
L – Left hand (counterclockwise)
Omit for right hand (clockwise)

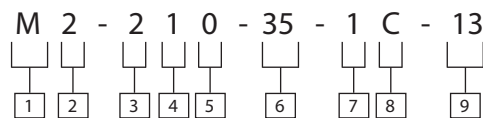

- 1** Vane motor
- 2** Series (bi-directional rotation)
- 3** Series frame size
- 4** Porting
1-3/4 NPT both ports
- 5** Mounting
0 – 2 bolt flange
- 6** Ring size – torque
lb. in./100 psi
25 and 35
- 7** Shaft type
1 – Straight keyed
3 – Threaded
6 – Straight keyed (stub)
11 – Splined
- 8** Cover position
(Viewing cover end)
A – Cover port opposite body port
B – Cover port 90 CCW from body port
C – Port connections in line
D – Cover port 90 CW from body port
- 9** Design
Subject to change. Installation dimensions remain the same for designs –10 through –19.

Installation Dimensions

M2U series

Dimensions in millimeters (inches)
 Shaft options shown on page 101.

Model	Dimensions	
	A	B
M2U-1S18S-1C10	129,8 (5.11)	105,4 (4.15)
M2U-1S25S-1C10	136,1 (5.36)	111,8 (4.40)
M2U-1S35S-1C10	141,0 (5.55)	116,6 (4.59)

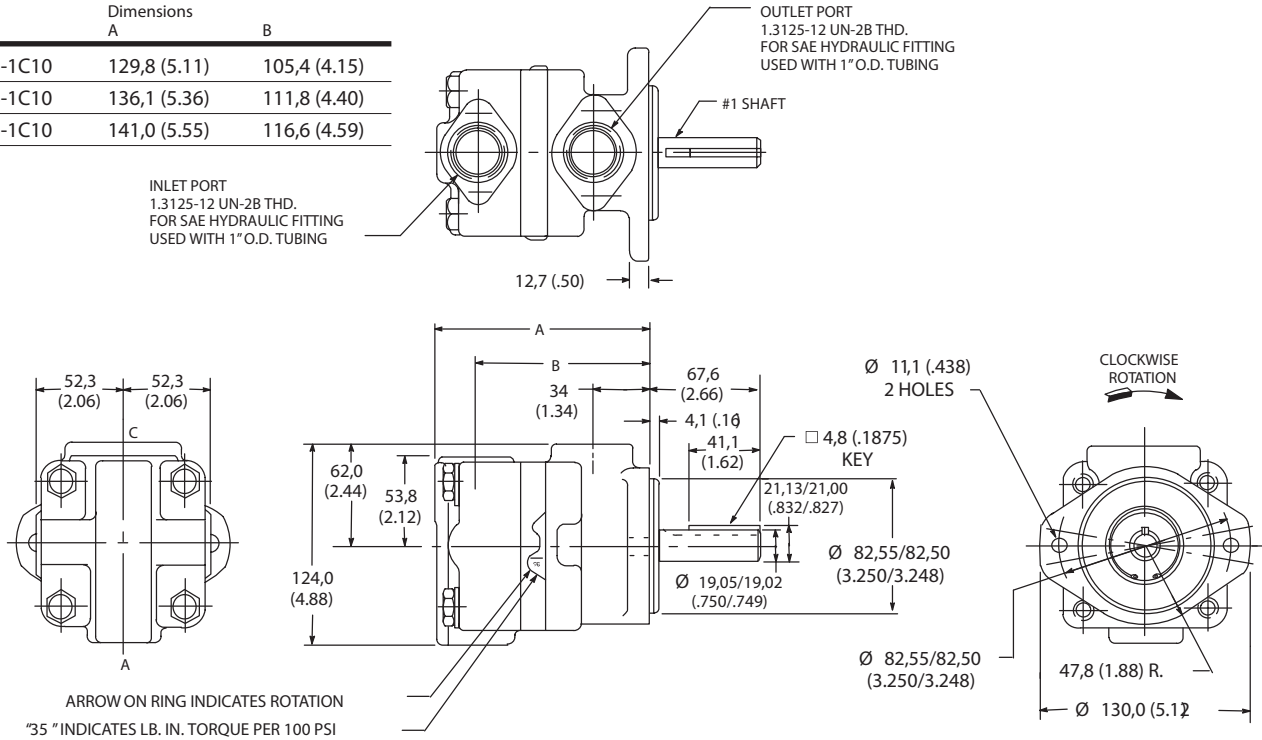

M2-200 series

Dimensions in millimeters (inches)
 Shaft options shown on page 101.

Fluid supply to connection "L" provides clockwise shaft rotation, viewed from shaft end.

Fluid supply to connection "K" provides counterclockwise shaft rotation.

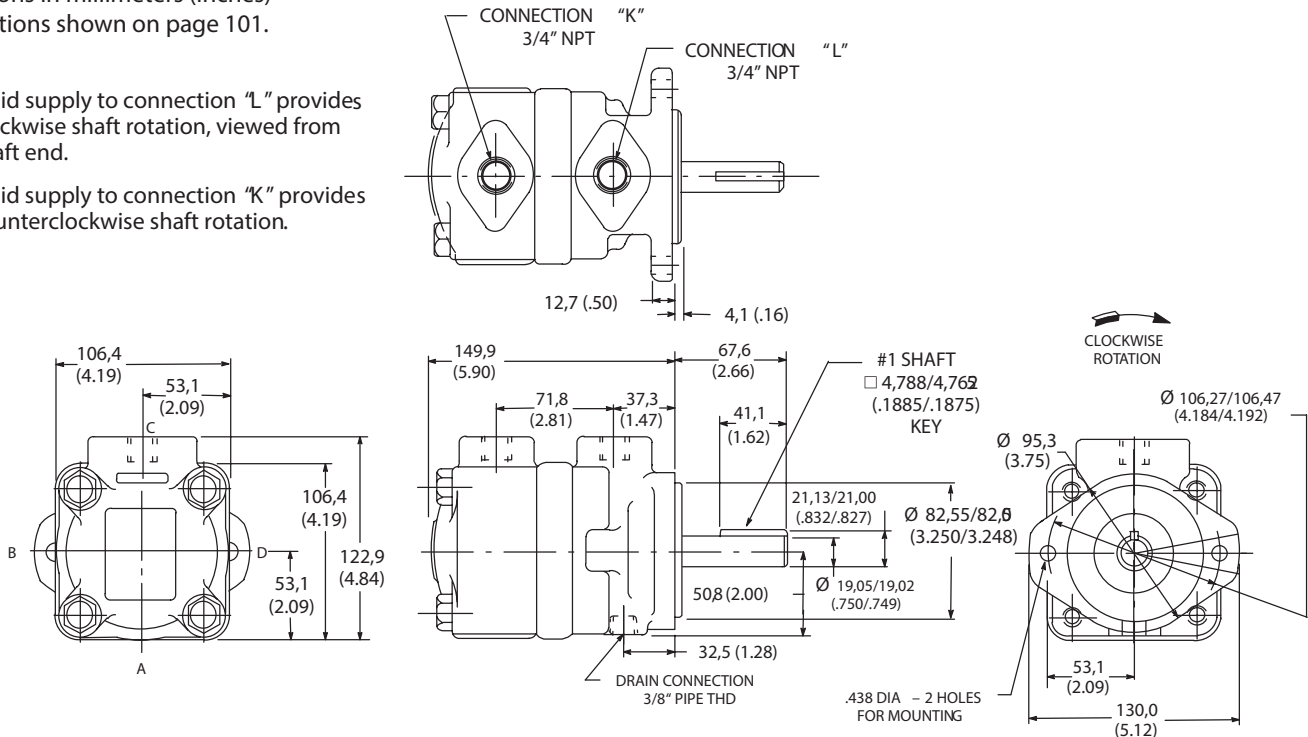

Optional Shafts

V10 Series

Dimensions in millimeters (inches)

Note: No. 1 keyed shaft and No. 38 splined shaft shown on pages 71 and 72 respectively.

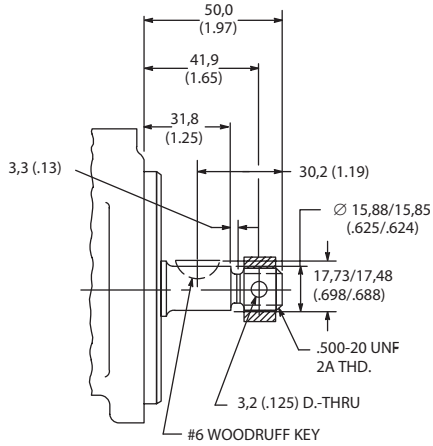

No. 3 shaft extension

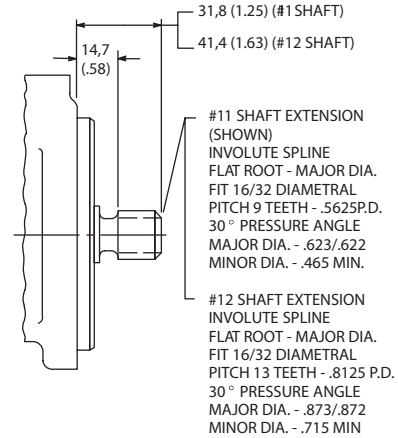

No. 11 & 12 shaft extension

V20 Series

Dimensions in millimeters (inches)

Note: No. 1 keyed shaft and No. 38 splined shaft shown on pages 72 and 73 respectively. No. 62 splined shaft same as V10 #11 shaft shown above.

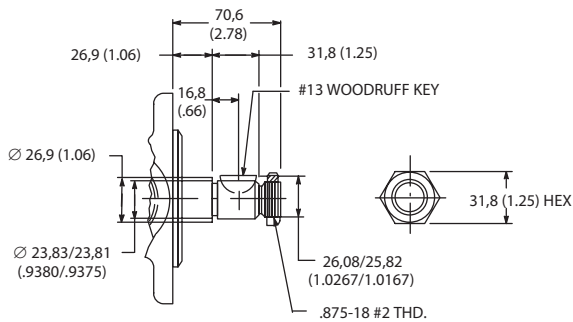

No. 3 shaft extension

Note: No. 3 shaft recommended nut torque 170 Nm (125 lb. ft.)

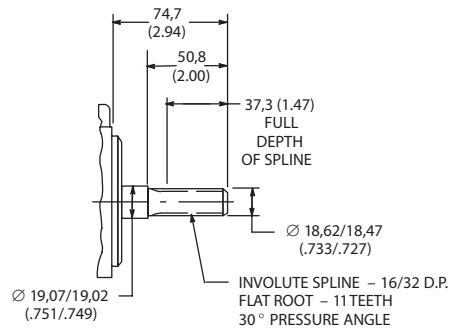

No. 11 shaft extension

Optional Shafts

M2U & M2-200 series

Dimensions in millimeters (inches)

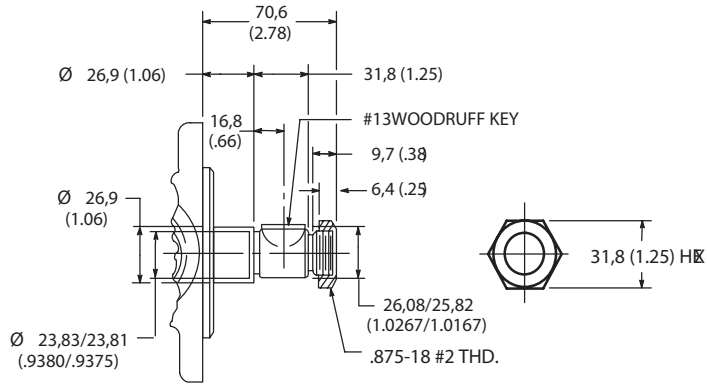

No. 3 threaded shaft

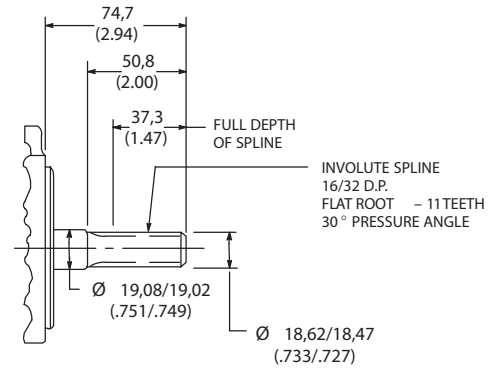

No. 11 splined shaft

NOTE:

Nut torque 169,5 Nm (125 lb. ft.)

M2-200 series

Dimensions in millimeters (inches)

NOTE: No. 1 keyed shaft is shown on page 100.

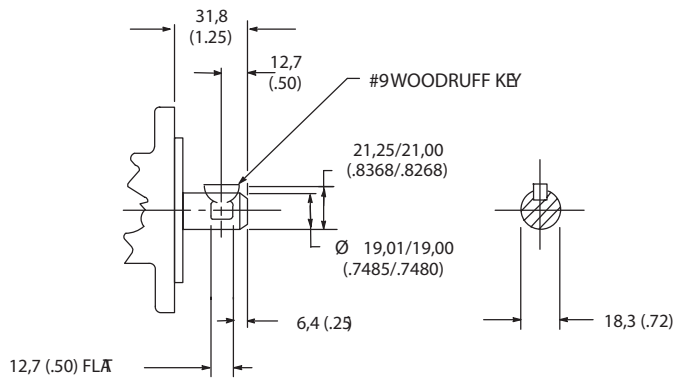

No. 6 straight stub shaft

Typical Performance

M2U Series

Performance Constants:

Oil temp. 49 ° C (120 ° F), viscosity
32 cSt (150 SUS) @ 38 ° C (100° F)

18 LB. IN. RING

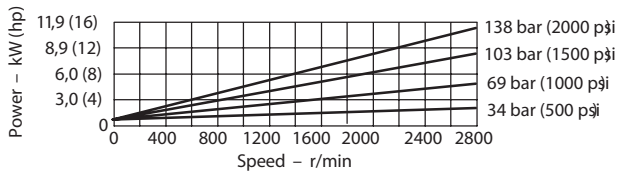
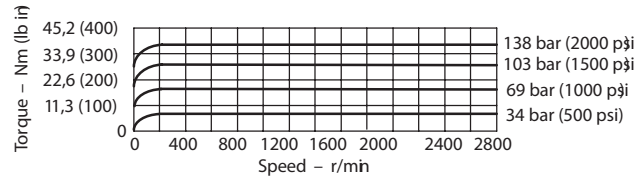
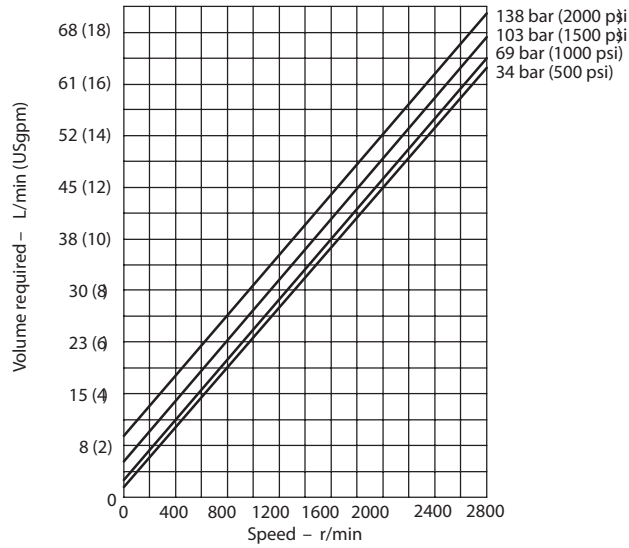

25 LB. IN. RING

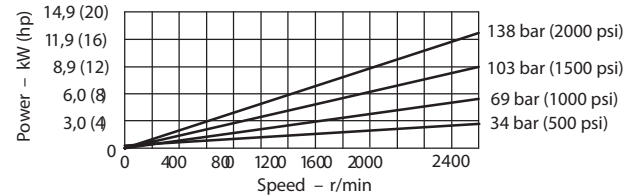
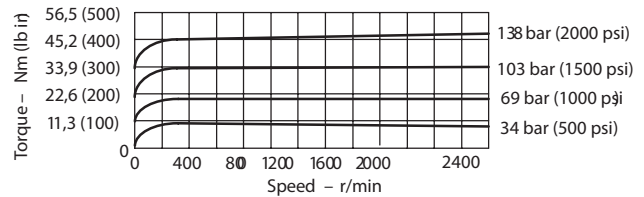
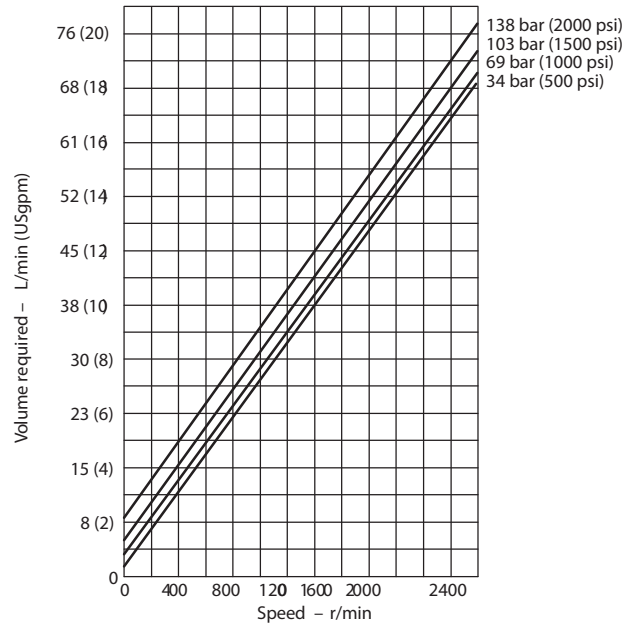

Typical Performance

M2U Series

Performance Constants:

Oil temp. 49 °C (120 °F), viscosity
32 cSt (150 SUS) @ 38 °C (100 °F)

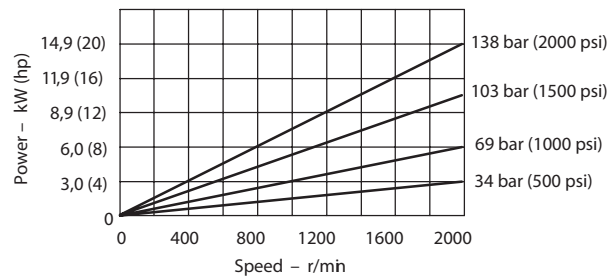
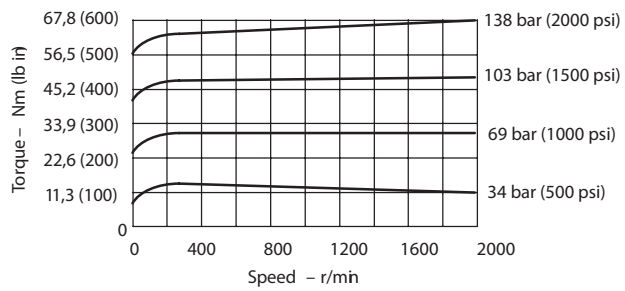
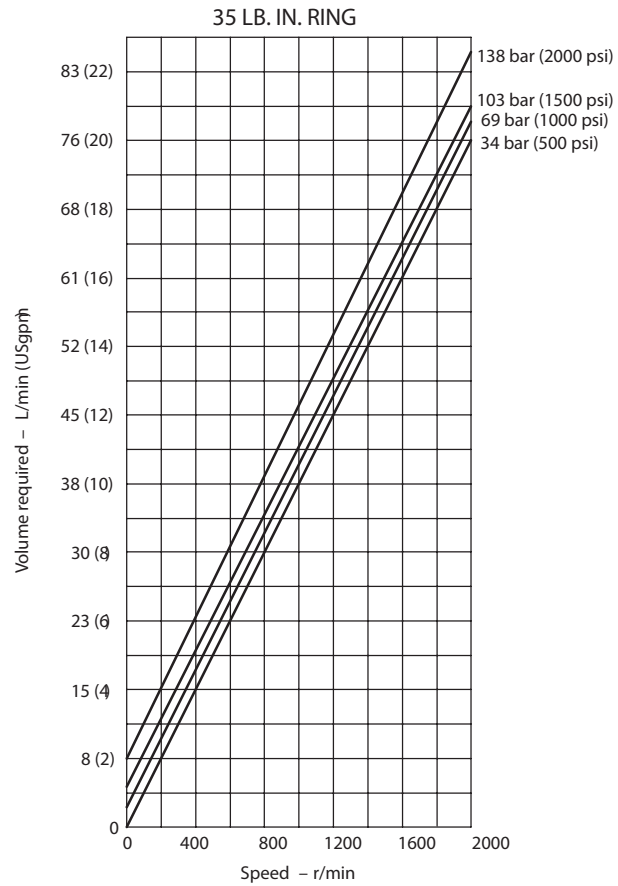

M2-200 Series

Performance Constants:
 Oil temp. 49 ° C (120° F), viscosity
 32 cSt (150 SUS) @ 38 ° C (100 ° F)

25 LB. IN. RING

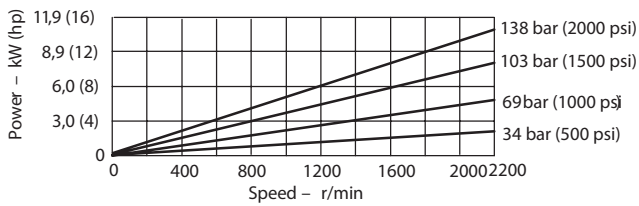
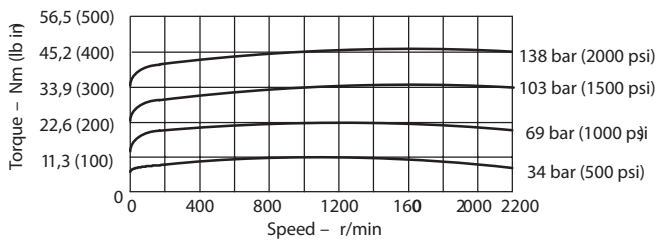
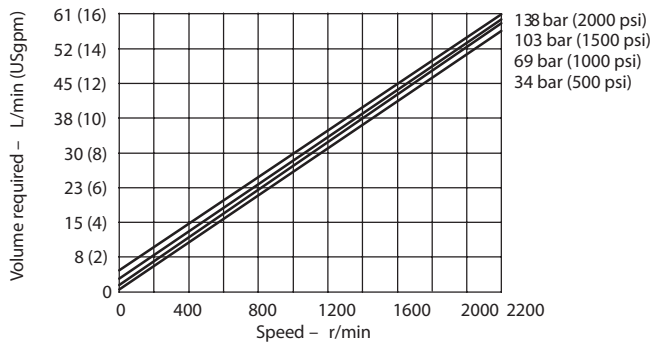

35 LB. IN. RING

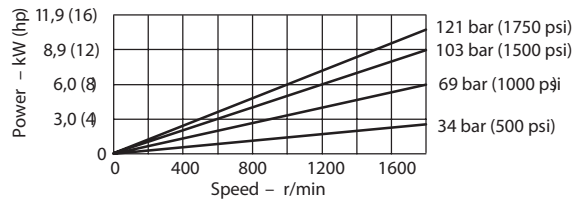
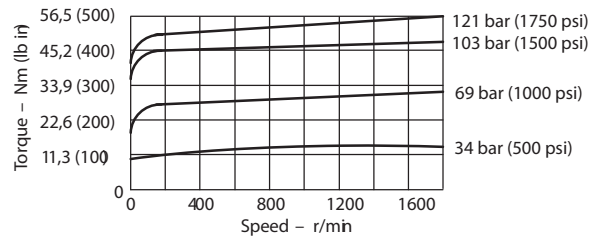
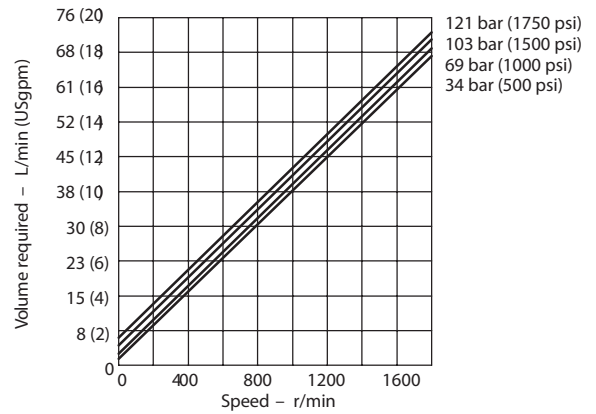

High Speed - High Pressure Motors from 43,9 to 317,1 cm³/r (2.68 to 19.35 in³/r)

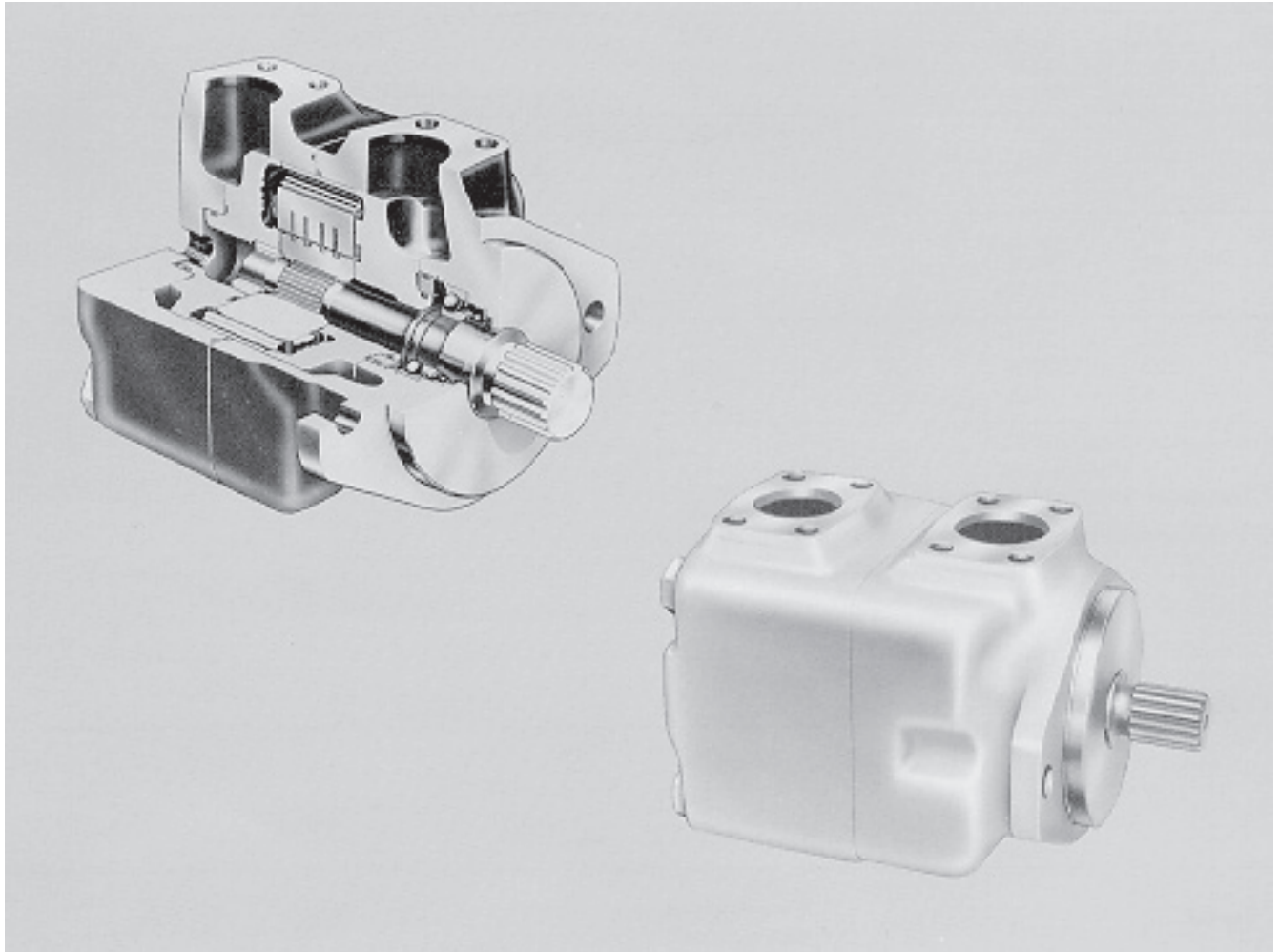

Reliable

Danfoss has field-proved these high performance motors over many years. They have been overwhelmingly successful on elevator scraper drives, hydrostatic drives and many other auxiliary applications.

Efficient

Danfoss' exclusive dual-alternate pressure plate design provides overall efficiency of about 86%.

Reversibility

Through the dual plate design, the motors may be reversed simply by reversing the direction of oil flow. See note below table on page 106 regarding pressure/rotation of model series 50M.

Series Operation

Inlet and outlet ports can be pressurized simultaneously without affecting service life or operating smoothness. These motors are suited to series applications. See note below table on page 106 regarding pressure/rotation of model series 50M.

Replaceable Cartridge

Replaceable cartridges permit motor overhauls in just 10 minutes - in the field! A cartridge can be replaced without removing the unit from the vehicle, and usually without disconnecting hydraulic lines.

High Speed and Pressure

These motors offer speeds to 3000 rpm at maximum pressure. Speeds up to 4000 rpm are obtainable, as in transmission applications where high travel speeds under light loads are required.

Operating Specifications

Model Series	Torque Nm/6,9 bar (lb. in./100 psi)	Displacement cm ³ /r (in. ³ /r)	Flow Input @ 1200 r/min L/min (USgpm)	Max. Torque Nm (lb. in.) @ Max. Pressure	Maximum Speeds & Pressure	Approx. Weight kg (lb)
25M	4,7 (42)	43,9 (2.68)	52,7 (13.9)	115,8 (1025)	4000 r/min @ 34 bar (500 psi)	18 (40)
	6,2 (55)	57,7 (3.52)	69,4 (18.3)	151,4 (1340)		
	7,3 (65)	68,7 (4.19)	82,6 (21.8)	180,8 (1600)		
35M	9,0 (80)	83,6 (5.10)	100,4 (26.5)	221,5 (1960)	3000 r/min @ 172 bar (2500 psi)	29 (64)
	10,7 (95)	100,3 (6.12)	120,5 (31.8)	264,4 (2340)		
	13,0 (115)	121,9 (7.44)	146,3 (38.6)	320,9 (2840)		
45M	14,7 (130)	138,0 (8.42)	165,6 (43.7)	361,6 (3200)	3200 r/min @ 34 bar (500 psi) 2400 r/min @ 172 bar (2500 psi)•	39 (85)
	17,5 (155)	163,2 (9.96)	195,9 (51.7)	429,4 (3800)		
	20,9 (185)	193,2 (11.79)	232,3 (61.3)	502,9 (4450)		
50M	24,9 (220)	231,3 (14.11)	277,8 (73.3)	615,9 (5450)	3200 r/min @ 34 bar (500 psi) 2400 r/min @ 172 bar (2500 psi)•	73 (160)
	28,8 (255)	268,2 (16.36)	322,2 (85.0)	717,6 (6350)		
	33,9 (300)	317,2 (19.35)	380,7 (100.5)	844,1 (7470)		

- 114 suffix: 2500 psi, counterclockwise
2250 psi, clockwise
- 124 suffix: 2500 psi, bi-directional

NOTE: Review "Applying Vane Units" page 7, prior to selection of motors.

Model Codes

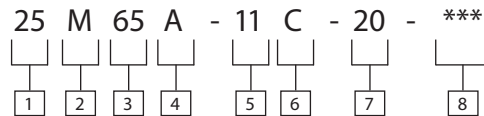

1 Series

25M }
35M } Standard
45M } bearing
50M }

26M }
36M } Heavy duty
46M } bearing
51M }

2 Vane motor

3 Ring size - Nominal torque rating (lb. in./100 psi)

25M – 42, 55 & 65
35M – 80, 95 & 115
45M – 130, 155 & 185
50M – 220, 255 & 300

4 Mounting flange & port connections

A – SAE type 2-bolt mounting flange
and SAE 4-bolt flange connections

5 Shaft

1 – Straight keyed
11 – Splined

6 Cover position (Viewing cover end)

A – Cover port opposite body port
B – Cover port 90 CCW from body port
C – Port connections in line
D – Cover port 90 CW from body port

7 Design

Subject to change. Installation
dimensions remain the same for
designs –20 through –29.

8 Special features suffix

114 }
124 } 50M only

Installation Dimensions

25M Motors

Dimensions in millimeters (inches)

Shaft options shown on page 109

Port connection pads are for use with SAE 4-bolt flanges. See page 121 for selection.

Fluid supply to connection "L" turns shaft clockwise as viewed from shaft end. Fluid supply to connection "K" turns shaft counterclockwise.

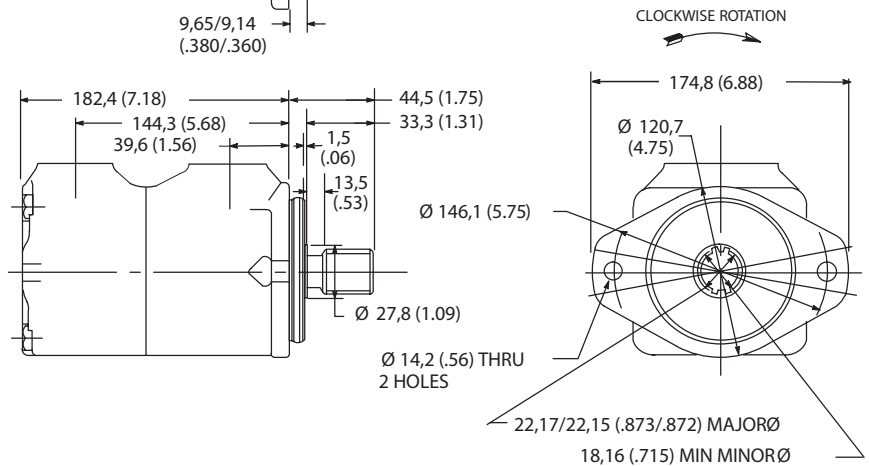
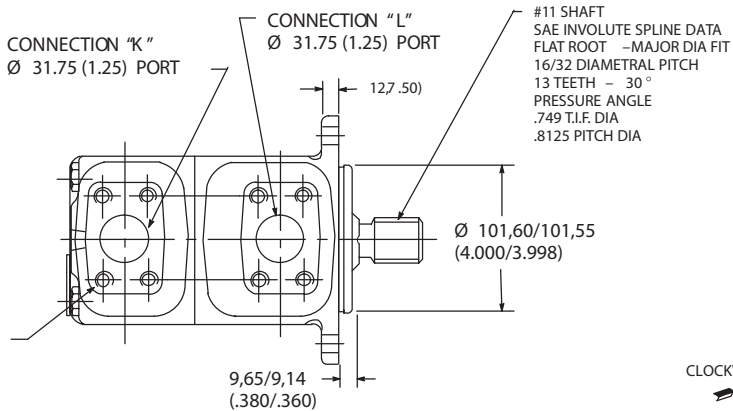
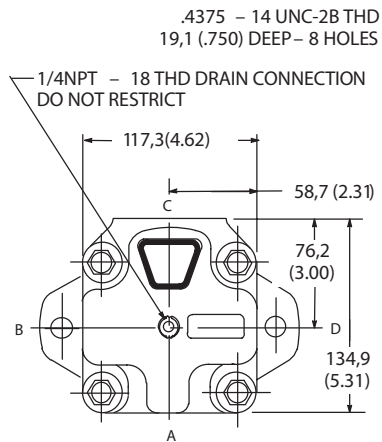

35M Motors

Dimensions in millimeters (inches)

Shaft options shown on page 109.

Port connection pads are for use with SAE 4-bolt flanges. See page 121 for selection.

Fluid supply to connection "L" turns shaft clockwise as viewed from shaft end. Fluid supply to connection "K" turns shaft counterclockwise.

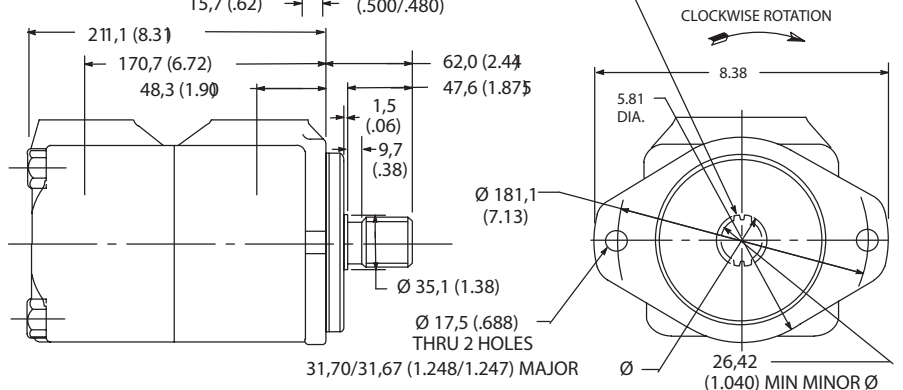
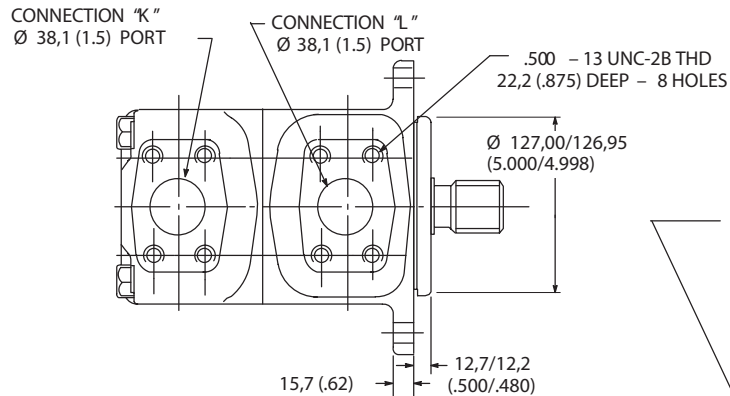
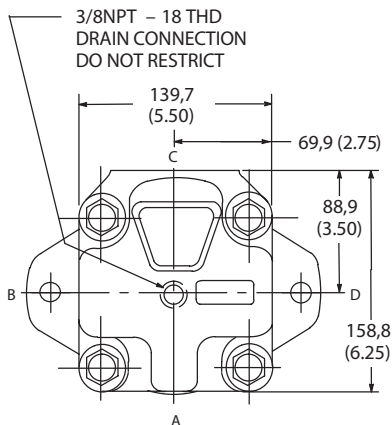

45M Motors

Dimensions in millimeters (inches)
Shaft options shown on page 109

Port connection pads are for use with SAE 4-bolt flanges. See page 121 for selection.

Fluid supply to connection "L" turns shaft clockwise as viewed from shaft end.
Fluid supply to connection "K" turns shaft counterclockwise.

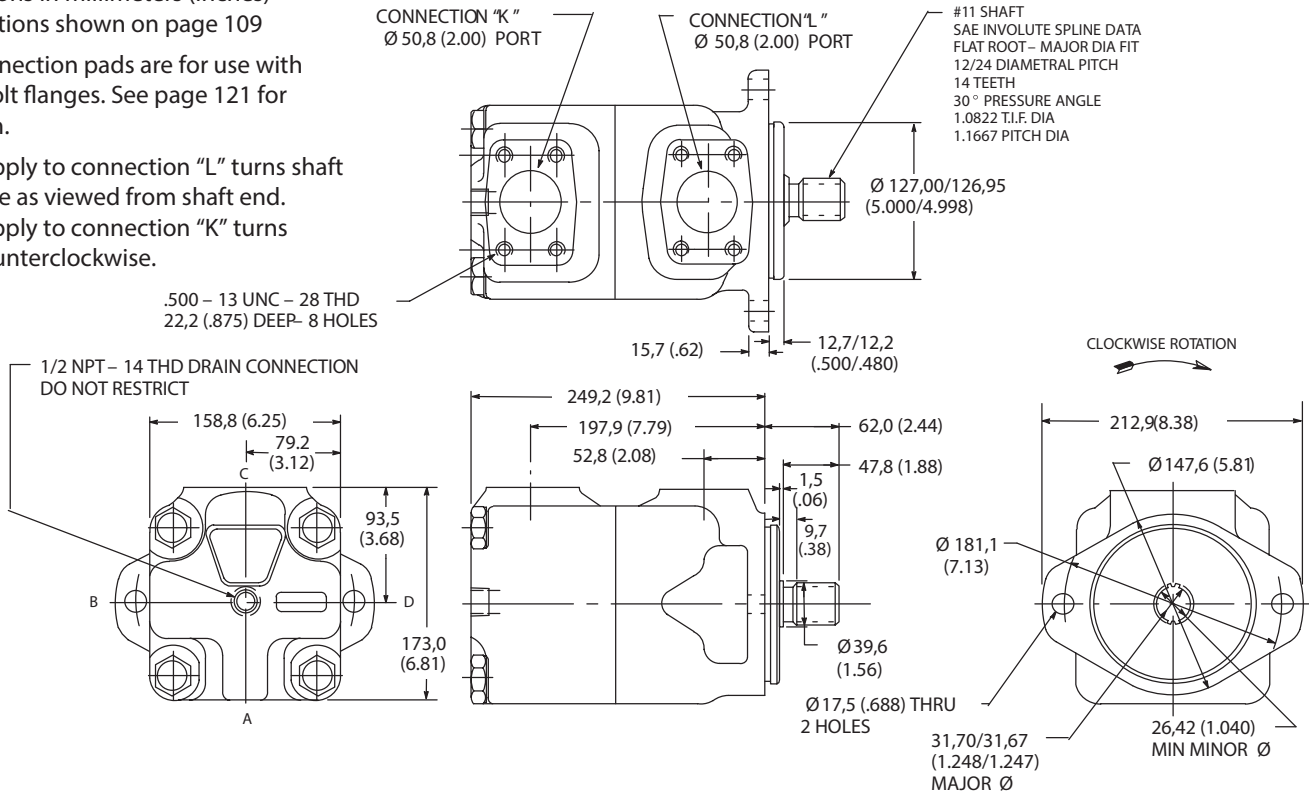

CONNECTION "K" Ø 63,5 (2.50) PORT
FLUID SUPPLY TO CONNECTION "K" TURNS SHAFT COUNTERCLOCKWISE

CONNECTION "L" Ø 63,5 (2.50) PORT
FLUID SUPPLY TO CONNECTION "L" TURNS SHAFT CLOCKWISE

50M Motors

Dimensions in millimeters (inches)
Shaft options shown on page 109.

Port connection pads are for use with SAE 4-bolt flanges. See page 121 for selection.

Fluid supply to connection "L" turns shaft clockwise as viewed from shaft end. Fluid supply to connection "K" turns shaft counterclockwise.

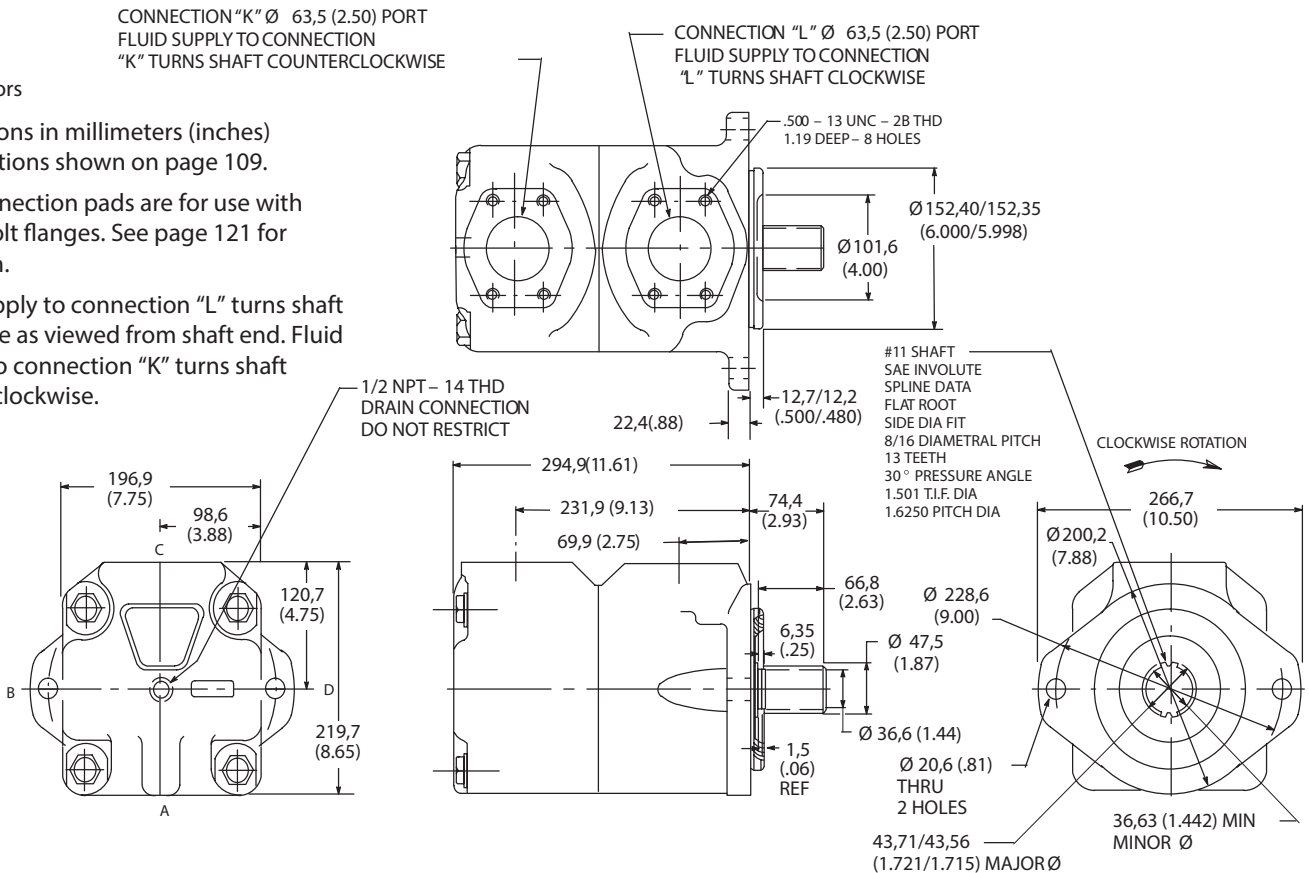

Optional Shafts

25M series

No. 1 straight keyed shaft

Dimensions in millimeters (inches)

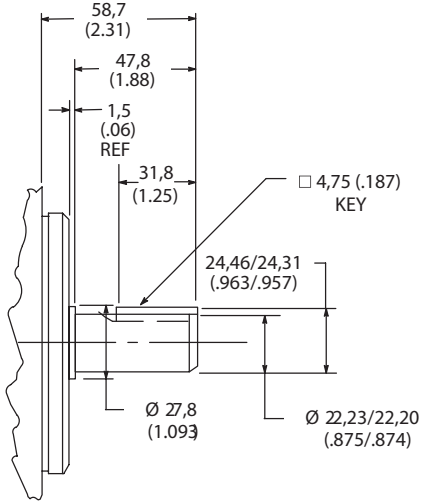

35M & 45M series

No. 1 straight keyed shaft

Dimensions in millimeters (inches)

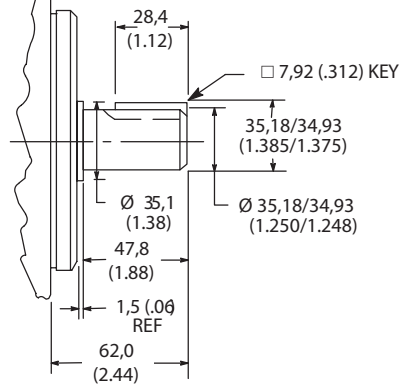

50M series

No. 1 straight keyed shaft

Dimensions in millimeters (inches)

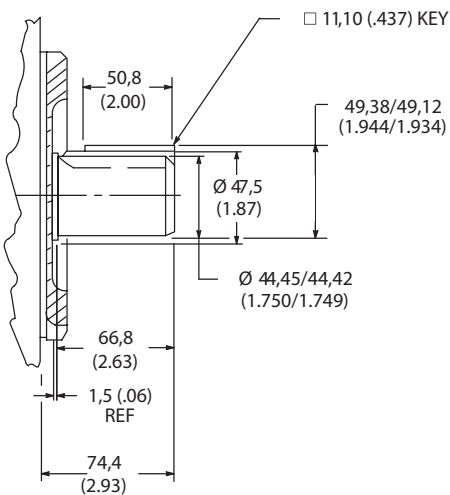

Typical Performance

25M Motors

Performance Constants:

Oil SAE 10W, viscosity 32 cSt (150 SUS) @ 38 °C (100 °F)

42 LB. IN. MODEL

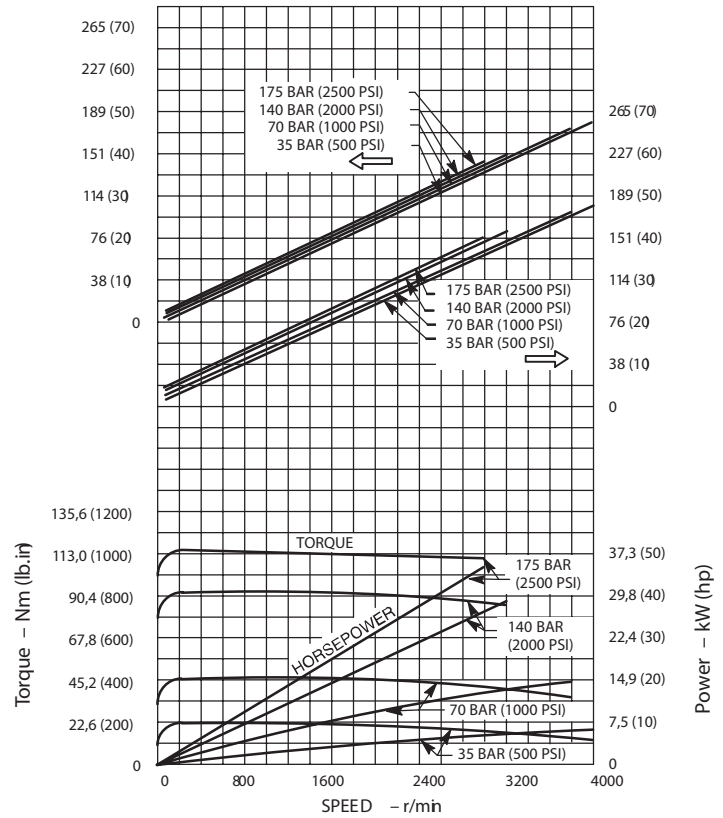

55 LB. IN. MODEL

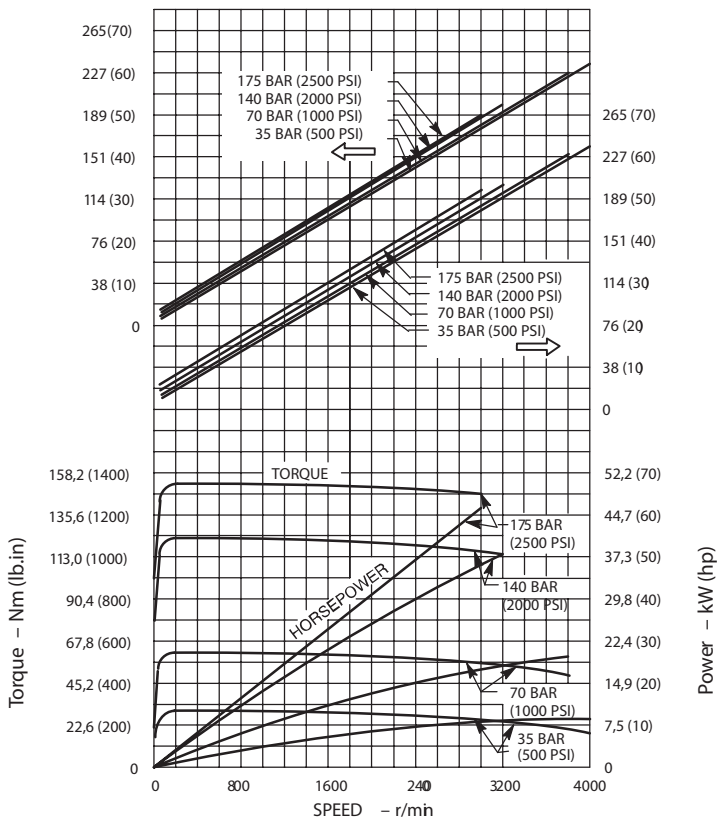

Typical Performance

25M Motors

Performance Constants:

Oil SAE 10W, viscosity 32 cSt (150 SUS) @ 38 ° C (100 ° F)

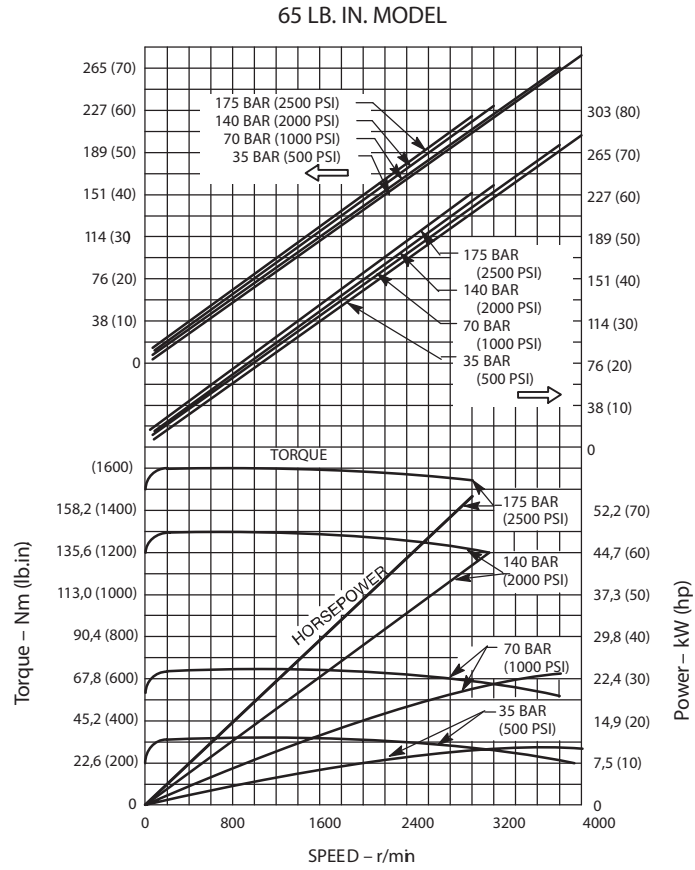

35M Motors

Performance Constants:

Oil SAE 10W, viscosity 32 cSt (150 SUS) @ 38 ° C (100 ° F)

80 LB. IN. MODEL

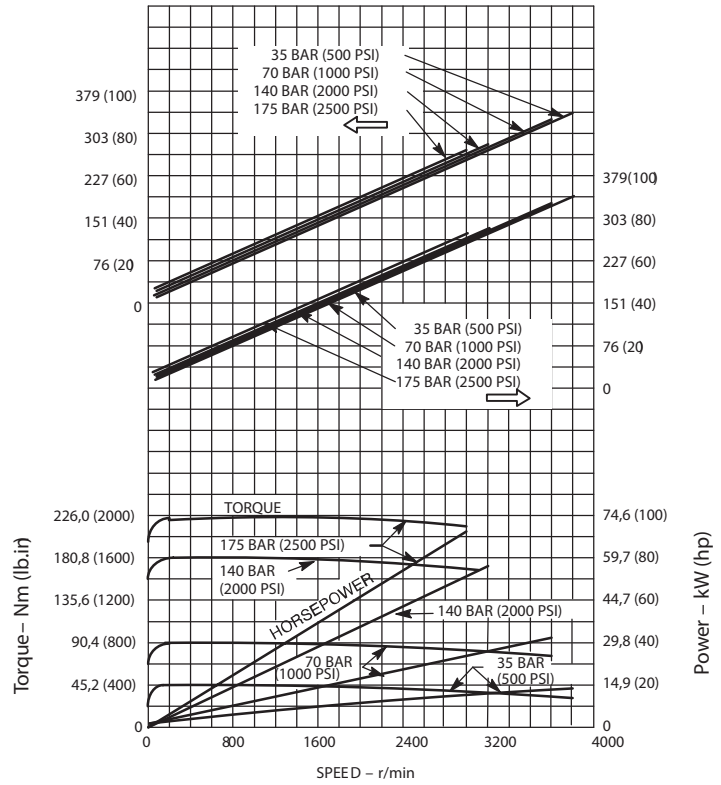

95 LB. IN. MODEL

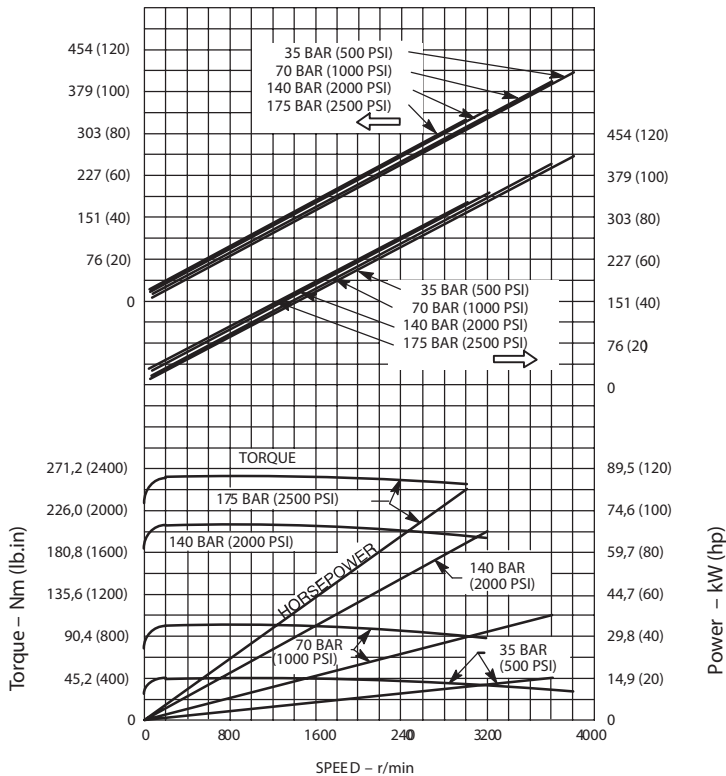

Typical Performance

35M Motors

Performance Constants:

Oil SAE 10W, viscosity 32 cSt (150 SUS) @ 38 ° C (100 ° F)

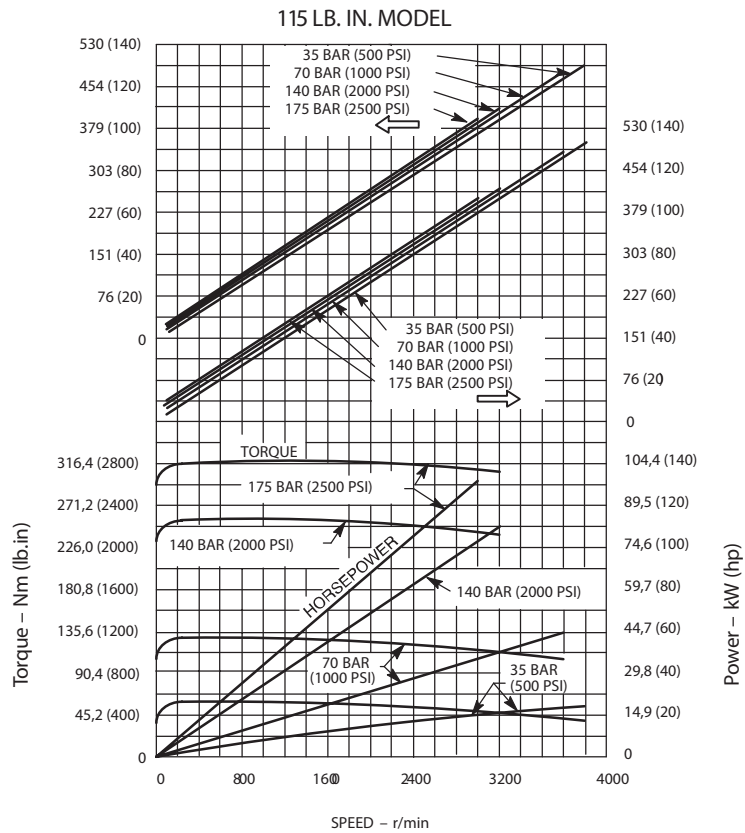

45M Motors

Performance Constants:

Oil SAE 10W, viscosity 32 cSt (150 SUS) @ 38 ° C (100 ° F)

130LB. IN. MODEL

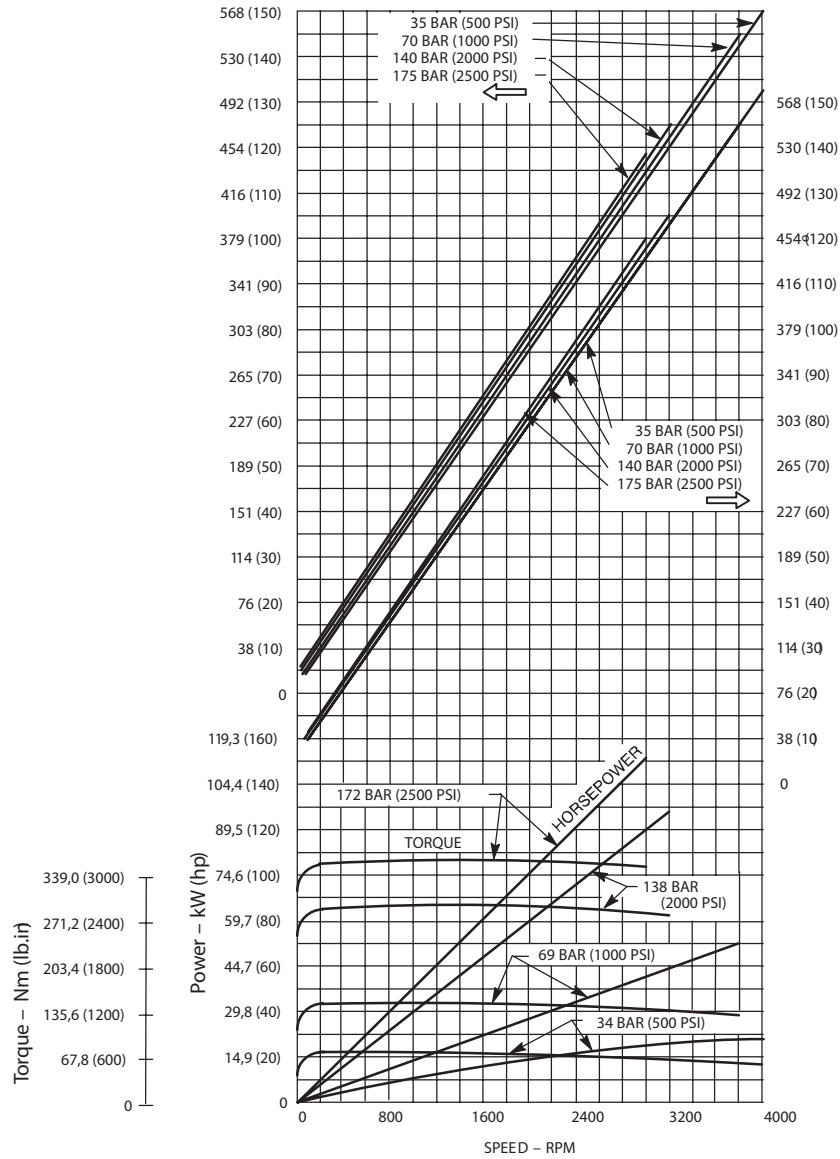

Typical Performance

45M Motors

Performance Constants:

Oil SAE 10W, viscosity 32 cSt (150 SUS) @ 38 ° C (100 ° F)

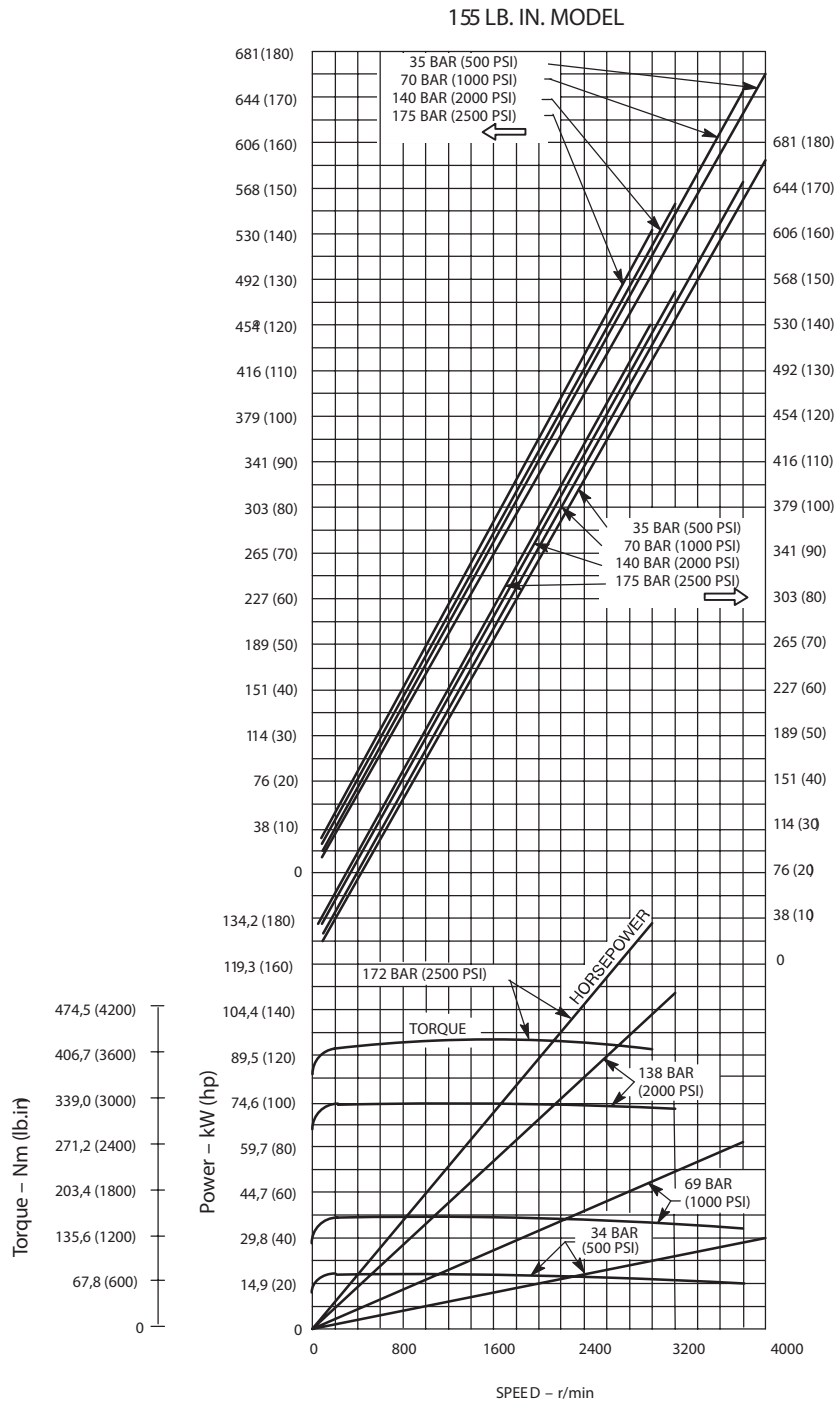

45M Motors

Performance Constants:
 Oil SAE 10W, viscosity 32 cSt (150 SUS)
 @ 38 ° C (100 ° F)

185LB. IN. MODEL

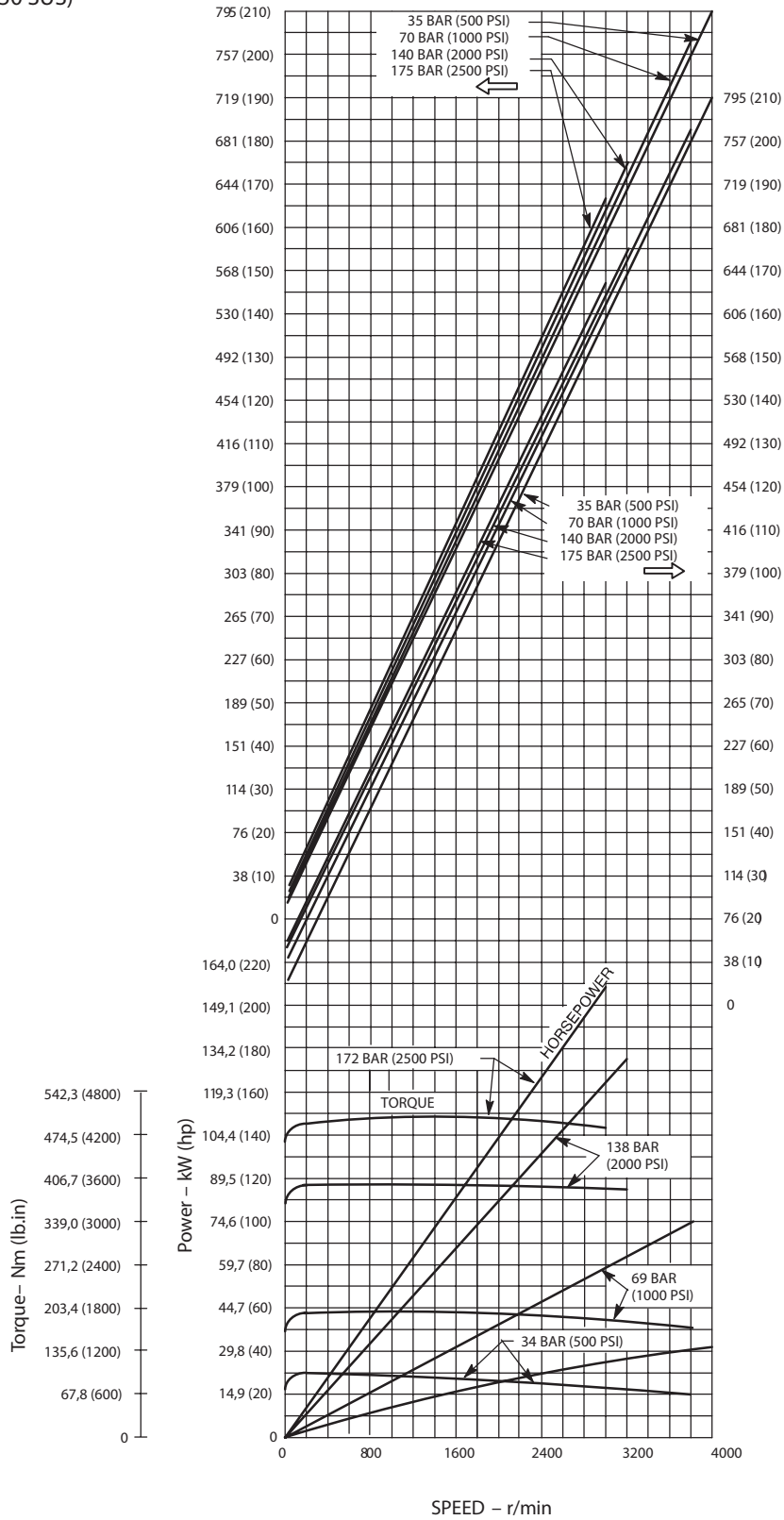

Typical Performance

50M Motors

Performance Constants:

Oil SAE 10W, viscosity 32 cSt (150 SUS) @ 38 ° C (100 ° F)

255LB. IN. MODEL

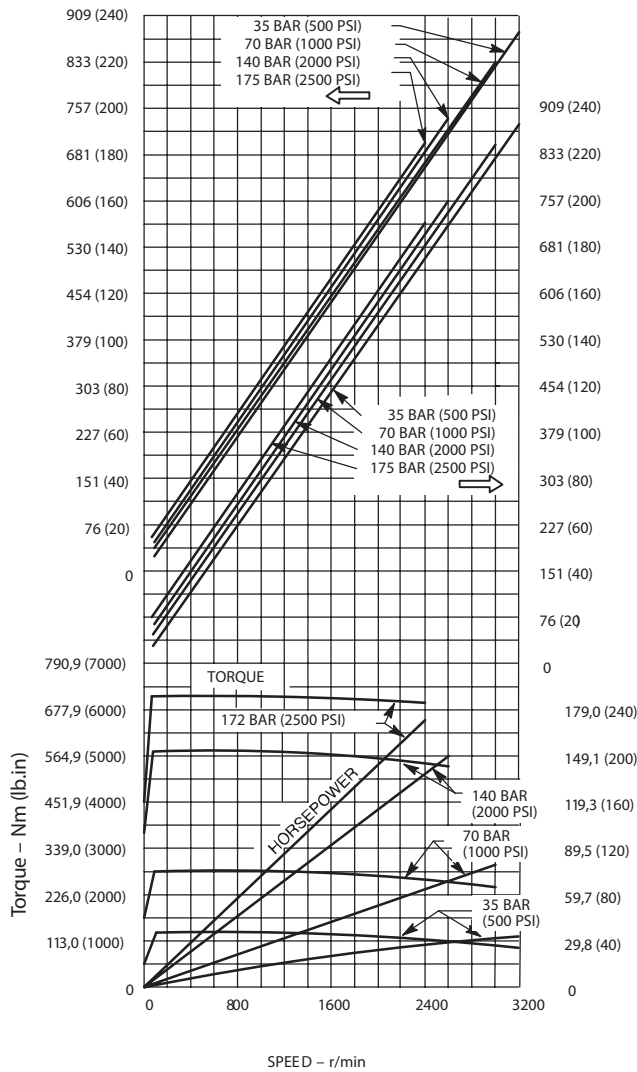

220LB. IN. MODEL

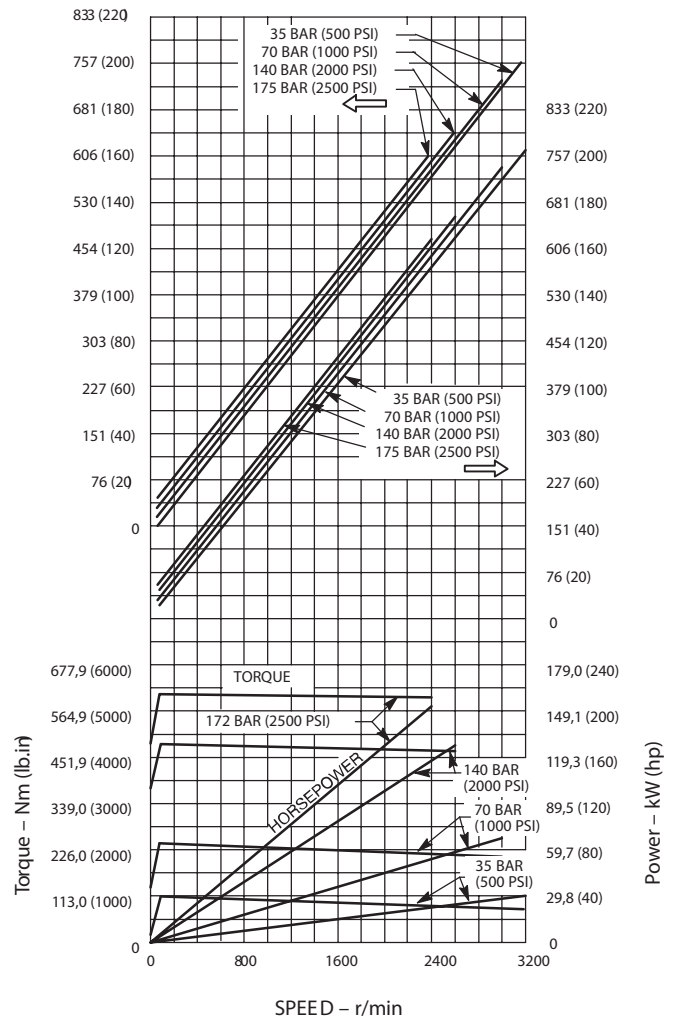

50M Motors

Performance Constants:

Oil SAE 10W, viscosity 32 cSt (150 SUS) @ 38 ° C (100 ° F)

300LB. IN. MODEL

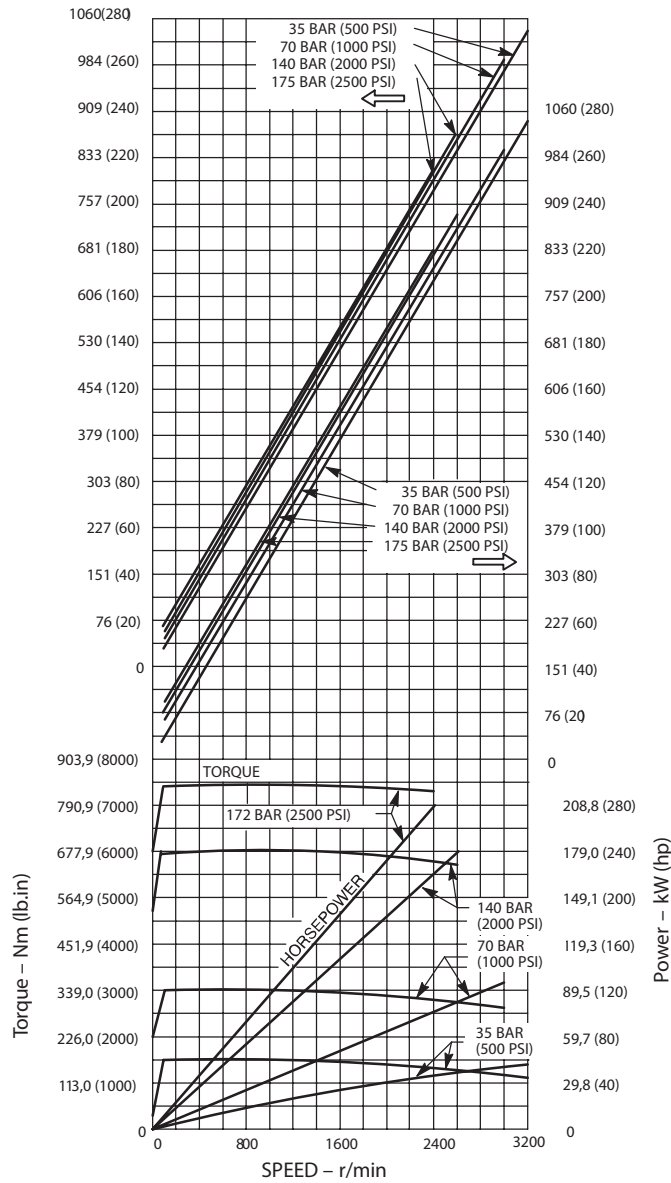

Foot Mounts

Foot bracket kits can be used to mount pumps or motors having standard SAE-J 744 2-bolt A, B, or C mounting flanges. These designations correspond to -A-, -B-, and -C- letters in the kit model number. Each kit includes a bracket and screws

for mounting to the pump or motor. Kits are not included with pumps and motors and must be ordered separately by model number.

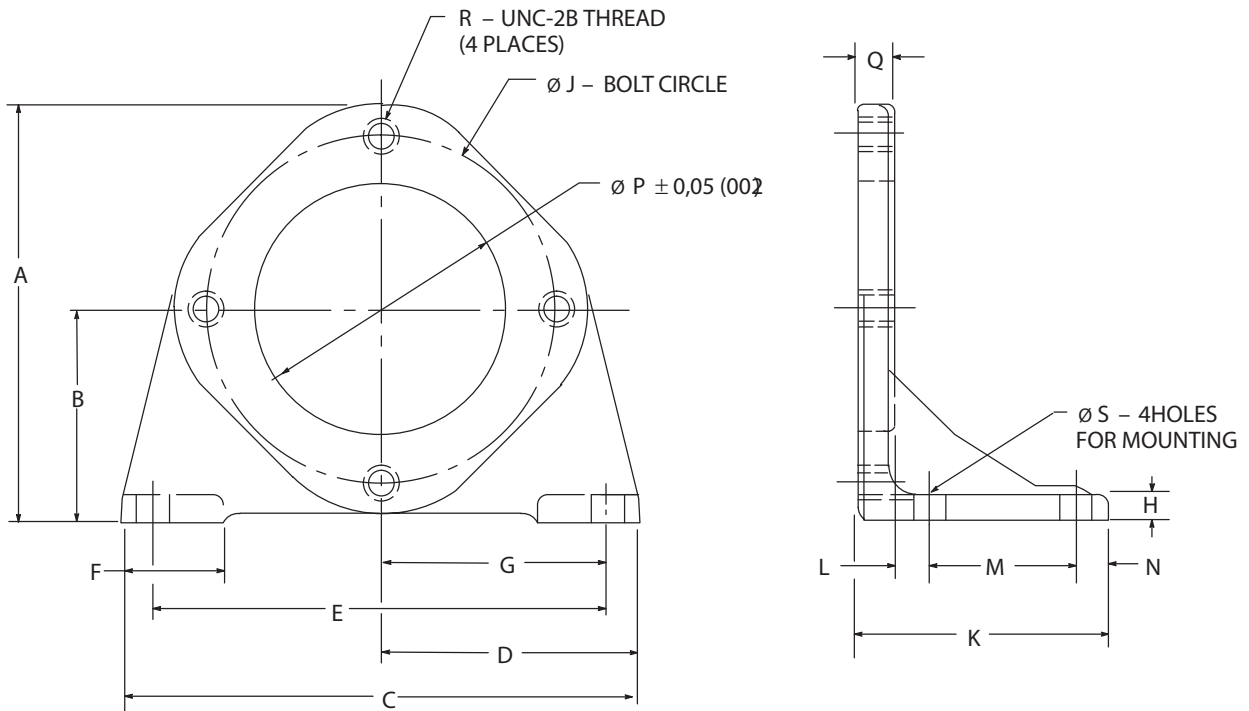

Model number	Dimensions - mm (in.)							
	A	B	C	D	E	F	G	H
FB-A-10	134,9 (5.31)	69,9 (2.75)	152,4 (6.00)	76,2 (3.00)	127,0 (5.00)	36,6 (1.44)	63,5 (2.50)	12,7 (.50)
FB-B-10	180,8 (7.12)	92,2 (3.63)	171,5 (6.75)	85,8 (3.38)	146,0 (5.75)	36,6 (1.44)	73,2 (2.88)	12,7 (.50)
FB-C-10	215,9 (8.50)	109,5 (4.31)	265,2 (10.44)	132,6 (5.22)	235,0 (9.25)	50,8 (2.00)	117,6 (4.63)	15,7 (.62)

Model number	Dimensions - mm (in.)								
	J	K	L	M	N	P	Q	R	S
FB-A-10	106,4 (4.19)	96,0 (3.78)	15,0 (.59)	50,8 (2.00)	12,7 (.50)	82,6 (3.25)	17,5 (.69)	.38-16	11,2 (.44)
FB-B-10	146,0 (5.75)	95,8 (3.77)	15,0 (.59)	50,8 (2.00)	12,7 (.50)	101,6 (4.00)	17,3 (.68)	.50-13	17,3 (.68)
FB-C-10	181,1 (7.13)	131,6 (5.18)	19,1 (.75)	76,2 (3.00)	17,3 (.68)	127,0 (5.00)	19,1 (.75)	.62-11	17,3 (.68)

Filler/Breather Unit

SP-113-C

Dimensions in millimeters (inches)

General Usage:

As a filler cap and air filter for hydraulic reservoirs.

Provides protected air vent opening, dirt screen and air filter.

Cover attached to neck of filter by means of a safety chain.

Prevents cap being lost or misplaced.

Pressure Drop VS. Oil Flow
Into/Out of Reservoir

L/min (USgpm)	Pressure Drop (Inches Hg)
57 (15)	.25
76 (20)	.50
91 (24)	.75
102 (27)	1.00

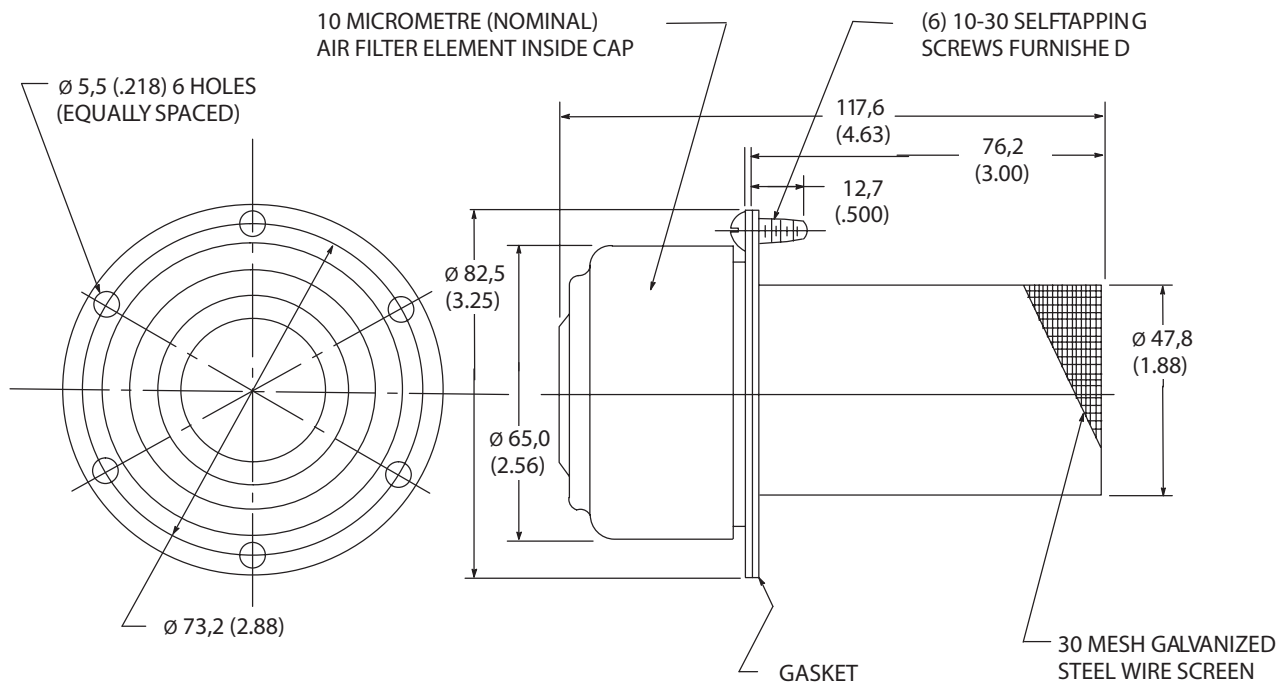

SAE 4-bolt Solid Flanges

Threaded Connection

Dimensions in millimeters (inches)

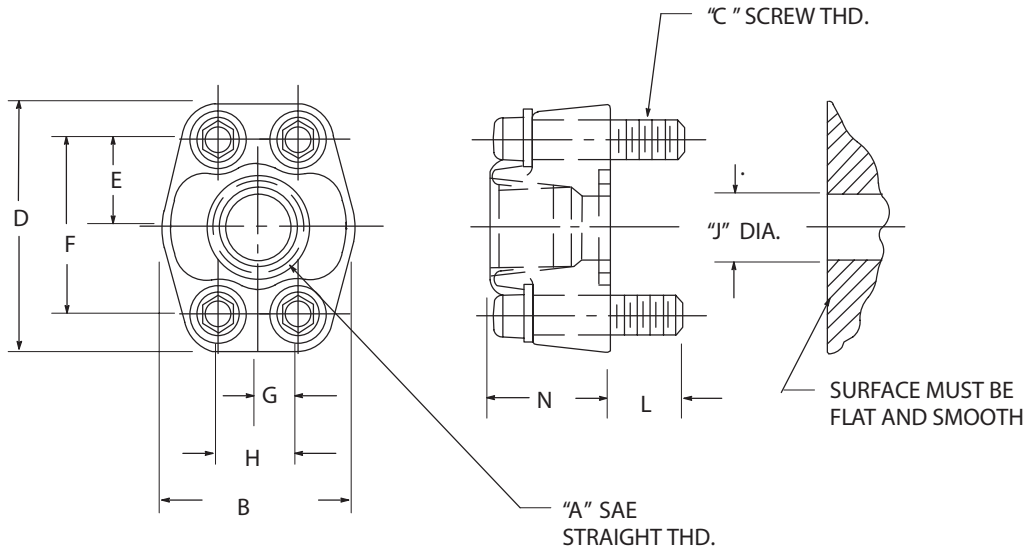

Model	Assembly	A SAE Straight Thread	B	C	D	E	F	G	H	J	L	N
FLI-6-12S-10	683829	1.0625-12 (3/4" tube)	52,3 (2.06)	3/8-16	65,0 (2.56)	23,9 (.94)	47,8 (1.88)	11,2 (.44)	22,4 (.88)	19,0 (.75)	13,5 (.53)	31,8 (1.25)
FLI-8-16S-10	683830	1.3125-12 (1" tube)	58,7 (2.31)	3/8-16	69,8 (2.75)	26,2 (1.03)	52,4 (2.06)	13,1 (.52)	26,2 (1.03)	25,4 (1.00)	16,8 (.66)	35,0 (1.38)
FL1-1 0-20S-10	683831	1.625-12 (1-1/4" tube)	73,1 (2.88)	7/16-14	79,2 (3.12)	29,4 (1.16)	58,7 (2.31)	15,1 (.59)	30,2 (1.19)	31,8 (1.25)	21,3 (.84)	38,1 (1.50)
FLI-12-24S-10	683832	1.875-12 (1-1/2" tube)	82,6 (3.25)	1/2-13	93,7 (3.69)	35,0 (1.38)	69,8 (2.75)	17,8 (.70)	35,7 (1.41)	38,1 (1.50)	18,5 (.73)	41,1 (1.62)

Oil Recommendations

The oil in a hydraulic system serves as the power transmission medium. It is also the system's lubricant and coolant. Selection of the proper oil is a requirement for satisfactory system performance and life.

The following recommendations will assist in the selection of suitable oils for use with Danfoss products. Danfoss does not publish a recommended oil list by brand name or supplier due to the extremely wide variety of oil types on the market.

In most cases, use of these recommendations will lead to selection of a suitable oil. However, due to the complex nature of oil formulation, the variety of oils available and peculiarities of individual hydraulic applications, there will be rare instances where oil selected on the basis of these recommendations will yield unsatisfactory results. Danfoss cannot be responsible for such exceptions. In this respect, the customer is encouraged to consult his Danfoss representative when selecting an oil.

Important Factors In Selecting An Oil

Additives –

Hydraulic fluids contain a number of additive agents which materially improve various characteristics of oil for hydraulic systems. These additives are selected to reduce wear, increase chemical stability, inhibit corrosion and depress the pour point.

Pump performance and reliability are directly affected by the antiwear additive formulation contained in the oil. Oils providing a high level of antiwear protection are recommended for optimum performance and long life.

Viscosity –

Viscosity is the measure of fluidity. The oil selected must have proper viscosity to maintain an adequate lubricating film at system operating temperature.

In addition to dynamic lubricating properties, oil must have sufficient body to provide an adequate sealing effect between working parts of pumps, valves, cylinders and motors, but not enough to cause pump cavitation or sluggish valve action.

Optimum operating viscosity of the oil should be between 16 cSt (80 SUS) and 40 cSt (180 SUS).

"Viscosity index" reflects the way viscosity changes with temperature; the smaller the viscosity change, the higher the viscosity index. The viscosity index of hydraulic system oil should not be less than 90. Multiple viscosity oils, such as SAE 10W30, incorporate additives to improve viscosity index (polymer thickened). Oils of this type generally exhibit both a temporary and permanent decrease in viscosity due to oil shear encountered in the operating hydraulic system. The actual viscosity can, therefore, be far less in the operating hydraulic system than what is shown in normal oil data. Accordingly, when such oils are selected, it is necessary to use those with high shear stability to ensure that viscosity remains within recommended limits while in service.

Chemical Stability –

Oxidative and thermal stability are essential characteristics of oils for Mobile hydraulic systems. The combination of base

stocks and additives should be stable during the expected lifetime of the oil when exposed to the environment of these systems.

Suitable Types Of Oil

Crankcase Oil –

Crankcase oil having letter designation SC, SD, SE or SF per SAE J183 Feb '80. Note that one oil may meet one or more of these designations.

Antiwear Hydraulic Oil –

These are produced by all major oil suppliers and should consist of good quality base stocks compounded with antiwear, anti-oxidation, and antirust additives.

Due to the large number of different antiwear hydraulic oils, it is impossible for Danfoss to test its products with all of them and recommend those that are suitable. Because of this, an evaluation procedure was developed for fluid suppliers to establish the suitability of their products for use in Danfoss components. Publication M-2952-S, "Pump Test Procedure for Evaluation of Antiwear Hydraulic Fluids for Mobile Systems," which gives the details of this test procedure, is available on request.

Certain Other Types Of

Petroleum Oil –

Other oils are suitable if they meet the following provisions:

1. Contain the type and content of antiwear additives found in the above designated crankcase oils, and have passed the pump tests as given in M-2952-S.
2. Have sufficient chemical stability for Mobile Hydraulic system service.
3. Meet the viscosity recommendations shown in the following tables.

Oil Viscosity Recommendations

Crankcase Oils –

Hydraulic System Operating Temp. Range*	SAE Viscosity Designation
-23° C to 54° C (-10° F to 130° F)	5W, 5W-20, 5W-30
-18° C to 83° C (0° F to 180° F)	10W
-18° C to 99° C (0° F to 210° F)	10W-30, 10W-40
-10° C to 99° C (14° F to 210° F)	20-20W

Antiwear Hydraulic Oils

Hydraulic System Operating Temp. Range*	ISO Viscosity Grade
-21° C to 60° C (-5° F to 140° F)	22
-15° C to 77° C (5° F to 170° F)	32
-9° C to 88° C (15° F to 190° F)	46
-1° C to 99° C (30° F to 210° F)	68

* Temperatures shown are cold (ambient) start-up to maximum operating. During cold start-up, avoid high-speed operation of hydraulic components until the system is warmed up to provide adequate lubrication.

Oil Recommendations and Hydraulic Formulae

Arctic Conditions

Arctic conditions represent a specialized field where extensive use is made of heating equipment before starting. If necessary, this and judicious use of the following recommendations should be used:

1. SAE 5W or 5W-20 oil.
2. Oils specially developed for use in arctic conditions, such as synthetic hydrocarbons, esters, or mixtures of the two. Skydrol must not be used. Operating temperature should be closely monitored to avoid exceeding a temperature of 54C (130F) with any lightweight oil.

Special Requirements

When special considerations indicate a need to depart from recommended oils or operating conditions, consult your Danfoss representative.

Horsepower:

$$\text{Horsepower} = \frac{\text{GPM} \times \text{PSI}}{1714}$$

Torque:

$$\text{Torque (lb.in.)} = \frac{\text{CU. IN. / Rev.} \times \text{PSI}}{\pi 2}$$

$$\text{Torque (lb.in.)} = \frac{\text{HP} \times 63025}{\text{RPM}}$$

Volumetric Efficiency:

$$\text{Volumetric efficiency (pump)} = \frac{\text{OUTPUT GPM}}{\text{THEORETICAL GPM}} \times 100$$

$$\text{Volumetric efficiency (motor)} = \frac{\text{THEORETICAL GPM}}{\text{INPUT GPM}} \times 100$$

Overall Efficiency:

$$\text{Overall efficiency} = \frac{\text{OUTPUT HP}}{\text{INPUT HP}} \times 100$$

Flow:

$$\text{Flow (gpm)} = \frac{\text{CU. IN. / REV.} \times \text{RPM}}{231}$$

Conversion Factors:

1 hp = 33,000 ft. lbs. per minute

1 hp = 42.4 btu per minute

1 hp = 0.746 kWhr (kilowatt hour)

1 U.S. gallon = 231 cubic inches

Pipe volume varies as the square of the diameter; volume in gallons = $0.0034 D^2 L$

where: D = inside diameter of pipe in inches

L = length in inches

$$\text{Velocity in feet per second} = \frac{0.408 \times \text{flow (gpm)}}{D^2}$$

where: D = inside diameter of pipe in inches.

Atmospheric pressure at sea level = 14.7 psi.

Atmospheric pressure decreases approximately 0.41 psi for each 1,000 feet of elevation to 23,000 feet.

Pressure (psi) = feet head x 0.433 x specific gravity.

Specific gravity of oil is approximately 0.85.

Thermal expansion of oil is about 1 cu. in. per 1 gallon per 10° F rise in temperature.

Flow Capacities of Piping

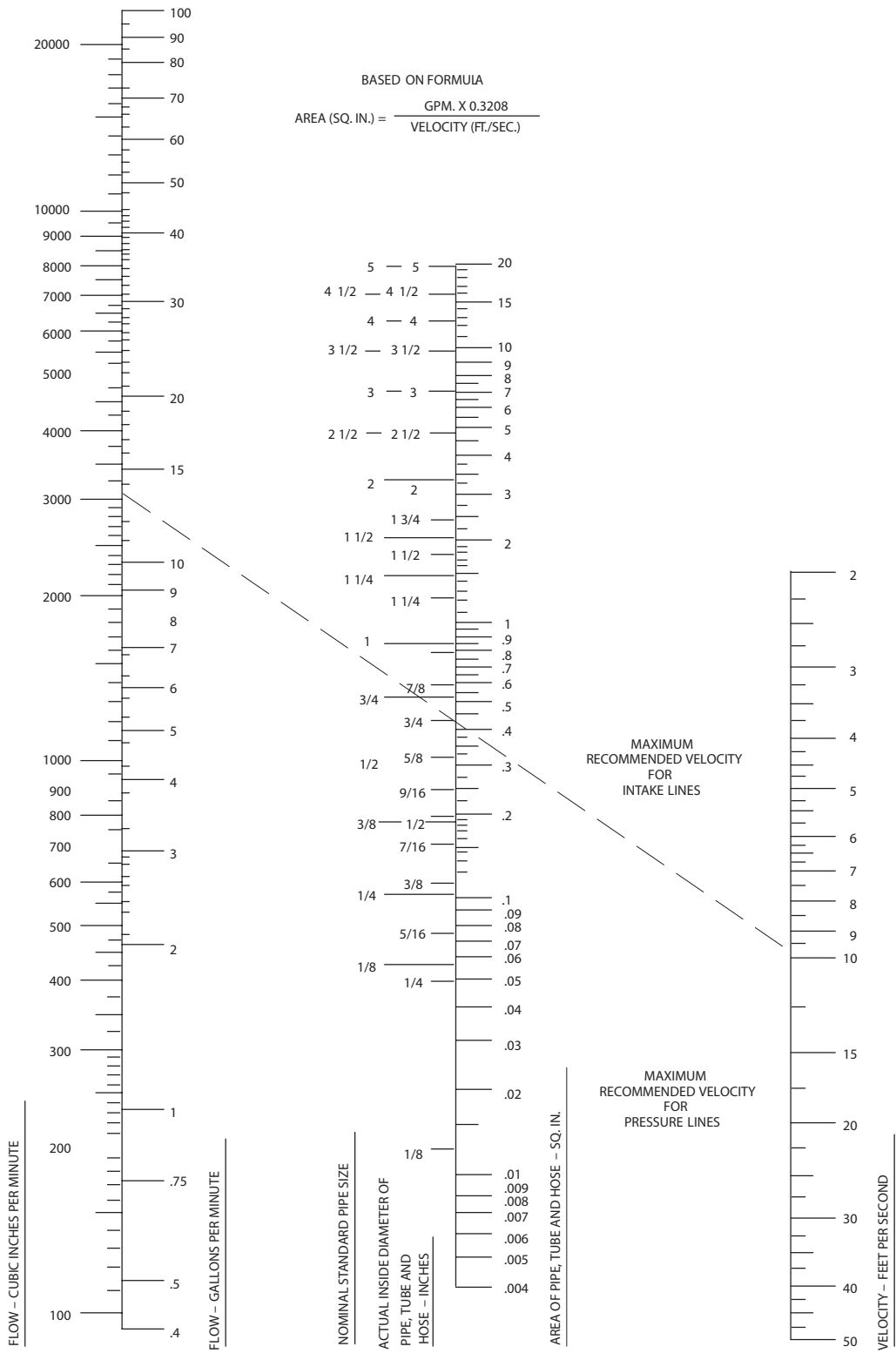

Products we offer:

- Cartridge valves
- DCV directional control valves
- Electric converters
- Electric machines
- Electric motors
- Gear motors
- Gear pumps
- Hydraulic integrated circuits (HICs)
- Hydrostatic motors
- Hydrostatic pumps
- Orbital motors
- PLUS+1® controllers
- PLUS+1® displays
- PLUS+1® joysticks and pedals
- PLUS+1® operator interfaces
- PLUS+1® sensors
- PLUS+1® software
- PLUS+1® software services, support and training
- Position controls and sensors
- PVG proportional valves
- Steering components and systems
- Telematics

Danfoss Power Solutions is a global manufacturer and supplier of high-quality hydraulic and electric components. We specialize in providing state-of-the-art technology and solutions that excel in the harsh operating conditions of the mobile off-highway market as well as the marine sector. Building on our extensive applications expertise, we work closely with you to ensure exceptional performance for a broad range of applications. We help you and other customers around the world speed up system development, reduce costs and bring vehicles and vessels to market faster.

Danfoss Power Solutions – your strongest partner in mobile hydraulics and mobile electrification.

Go to www.danfoss.com for further product information.

We offer you expert worldwide support for ensuring the best possible solutions for outstanding performance. And with an extensive network of Global Service Partners, we also provide you with comprehensive global service for all of our components.

Local address:

Hydro-Gear

www.hydro-gear.com

Daikin-Sauer-Danfoss

www.daikin-sauer-danfoss.com

**Danfoss
Power Solutions (US) Company**
2800 East 13th Street
Ames, IA 50010, USA
Phone: +1 515 239 6000

**Danfoss
Power Solutions GmbH & Co. OHG**
Krokamp 35
D-24539 Neumünster, Germany
Phone: +49 4321 871 0

**Danfoss
Power Solutions ApS**
Nordborgvej 81
DK-6430 Nordborg, Denmark
Phone: +45 7488 2222

**Danfoss
Power Solutions Trading
(Shanghai) Co., Ltd.**
Building #22, No. 1000 Jin Hai Rd
Jin Qiao, Pudong New District
Shanghai, China 201206
Phone: +86 21 2080 6201

Danfoss can accept no responsibility for possible errors in catalogues, brochures and other printed material. Danfoss reserves the right to alter its products without notice. This also applies to products already on order provided that such alterations can be made without subsequent changes being necessary in specifications already agreed. All trademarks in this material are property of the respective companies. Danfoss and the Danfoss logotype are trademarks of Danfoss A/S. All rights reserved.