

Low Maintenance Filter

FN1/FN4 Series

No more element replacement!

RoHS

Our unique element construction with back-flushing capability

The element of the filter is constructed of a series of grooved filter plates and wave washers placed one above the other.

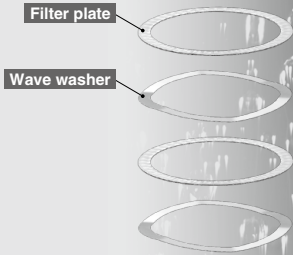

Element construction

When compressed

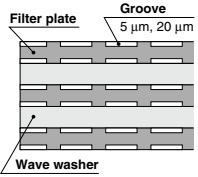

Gaps between the filter plates and wave washers filter foreign matter.

When decompressed

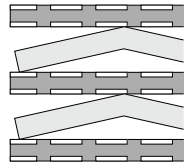

Decompressing the element widens the gap between filter plates and wave washers. While the gap is widened, dust and foreign matters caught between plates can be washed away by back-flushing the element. This restores the element and enables repeated use of the element. The gaps between filter plates are equally maintained by the wave washers to allow stable back-flush operation.

Eco-friendly regenerative filter

A unique stainless steel element construction with back-flushing capability generates no industrial waste, thus requires no element replacement.

FN1 Series

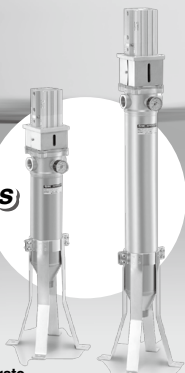

Flow rate
max. 40 L/min max. 80 L/min

FN4 Series



max. 250 L/min



FN4 Series with four elements



- FGD
- FGF
- FGG
- FGA
- FGC
- FGF
- FGH
- FQ1
- FN
- EB
- ES

Operating Principle

FN1 Series

 Fluid flow
  Air flow

Filtering

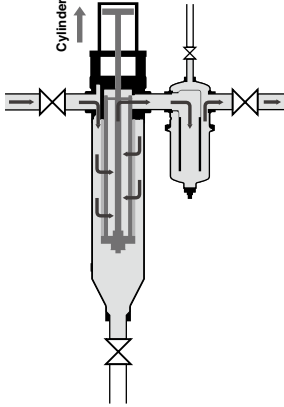

The element compressed by the cylinder filters the fluid.

Back-flushing

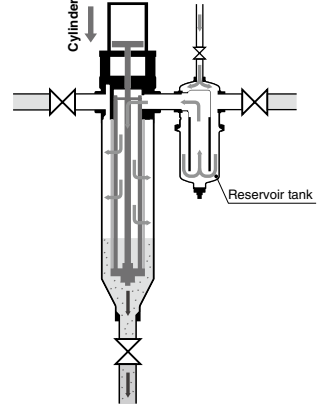

As the cylinder extends downward, the element is decompressed. Air pressure forces the fluid in the reservoir tank out to the filter and back-flushes the element.

FN4 Series

 Fluid flow
  Air flow

Filtering

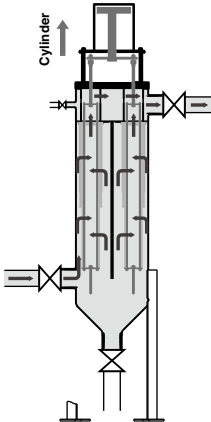

The element compressed by the cylinder filters the fluid.

Back-flushing

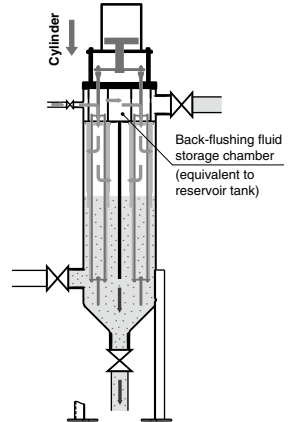

As the cylinder extends downward, the element is decompressed. Air pressure forces the fluid in the back-flushing fluid storage chamber (equivalent to reservoir tank) out to the filter and back-flushes the element.

Automatic Cleaning

System circuit allows the automatic cleaning of element when clogged.

(Refer to page 94 for details.)

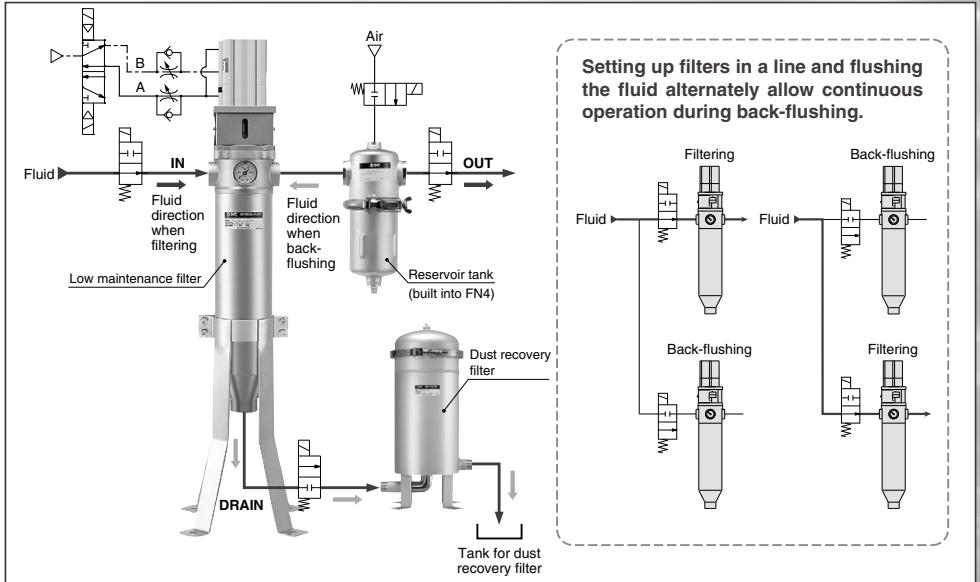

FGD

FGE

FGG

FGA

FGC

FGF

FGH

FQ1

FN

EB

ES

• Two types of elements to match different fluid conditions

Cylindrical type

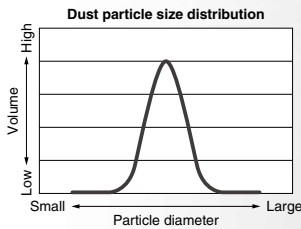

Upstream-side applicable dust particle size distribution

<Construction> The cylindrical type construction has a smooth surface since the dimension of the filter plate and wave washer are the same.

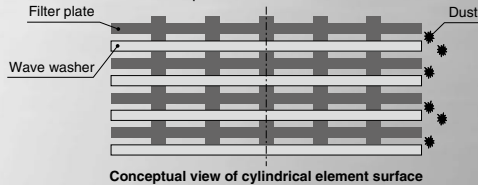

Conceptual view of cylindrical element surface

<Selection> Suitable for cases where there are dust particles with a narrow size distribution.

Step type

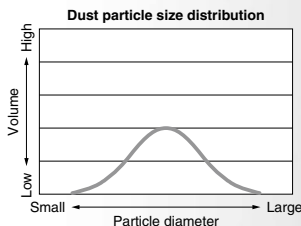

Upstream-side applicable dust particle size distribution

<Construction> The step type construction has an uneven (stepped) surface since the dimension of the filter plate and wave washer are different.

(Two-step filter in which outer step stops large-diameter dust particles and the inner step stops small-diameter dust particles.)

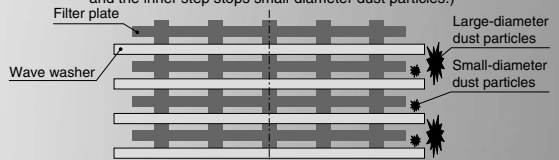

Conceptual view of step-type element surface

<Selection> Suitable for cases where there are dust particles with a wide size distribution.

Low Maintenance Filter

FN1/FN4 Series



How to Order

With single element **FN1 1 0 1 N - 10 - S 020**

With four elements **FN4 1 0 2 N - 20 - S 020**

Housing material

Symbol	Housing material
1	Stainless steel 304

Element type ^{Note)}

Symbol	Element type	Applicable model
0	Cylindrical type (5 μm, 20 μm)	FN1, FN4
1	Step type (5 μm)	FN1

Note) Refer to page 89 for detailed element type.

Element length

Symbol	Element length	Applicable model
1	L 250 mm	FN1
2	L 500 mm	FN1, FN4

Seal material

Symbol	Seal material
N	NBR
V	FKM

Pressure gauge

Symbol	Pressure gauge
Nil	None (With plug)
G ^{Note 1)}	With pressure gauge ^{Note 2)} (Wetted part: Brass)

Note 1) Contact SMC for the pressure gauge specification for stainless steel wetted parts.

Note 2) The FN4 series is equipped with two pressure gauges.

Nominal filtration rating

Symbol	Nominal filtration rating
005	5 μm (Cylindrical type, Step type)
020	20 μm (Cylindrical type)

Element material

Symbol	Element material
S	Stainless steel 304

Port size

Symbol	Port size	Applicable model
10	Rc1	FN1
20	Rc2	FN4

Specifications

Filter

Model	FN1101	FN1111	FN1102	FN1112	FN4102
Element dimension	ø65 x 250 L			ø65 x 500 L	
Fluid	Coolant (oil-based or water-soluble), Weak alkaline cleaning fluid, Cutting oil, Industrial water				
Operating pressure	Max. 1.0 MPa				
Fluid temperature ^{Note 1)}	Max. 80°C (For with pressure gauge: 60°C or less)				
Flow rate ^{Note 2)}	Approx. 40 L/min		Approx. 80 L/min		Approx. 250 L/min
Port size	Rc1 (IN, OUT, DRAIN)				Rc2
Material	Bowl and Cover: Stainless steel 304, O-ring: NBR/FKM				
Material	Stainless steel 304				
Construction	Cylindrical type	Step type	Cylindrical type	Step type	Cylindrical type
Nominal filtration rating	5 μm, 20 μm	5 μm	5 μm, 20 μm	5 μm	5 μm, 20 μm
Differential pressure proof	0.6 MPa				
Reservoir tank capacity	Approx. 1.1 L (when reservoir is set separately)		Approx. 1.8 L (when reservoir is set separately)		Approx. 6 L
Weight	13 kg	12.5 kg	15 kg	14.5 kg	65 kg

Note 1) The temperature will be 0°C to 60°C when the auto switch is mounted on the cylinder.

Note 2) Fluid: Water; Nominal filtration: 20 μm; Pressure drop: 0.02 MPa or less.

Operating Part

Model	CDLQB63-□D-F(FN1), CDLQA100-50-F(FN4)
Auto switch	None (Built-in magnet) ^{Note)}
Fluid	Air
Introduced pressure	0.25 to 0.3 MPa
Unlocking pressure	0.2 MPa or more
Locking pressure	0.05 MPa or more
Locking direction	Extension locking

Note) Auto switch must be ordered separately. Refer to the CLQ series (Compact Cylinder with Lock) "Best Pneumatics No.2-2" for details.



Options (Sold separately)

Reservoir tank: FNR Series

This tank is used to store sufficient fluid for back-flushing (for the FN1 series).

* Not required for the FN4, which has a built-in tank.



How to Order

RoHS

FNR10 0 N - 10

Symbol	Capacity	Applicable model
0	1.1 L	FN11□1
1	1.8 L	FN11□2

Size

Port size

Symbol	Port size
10	Rc1

Seal material

Symbol	Material
N	NBR
V	FKM

Specifications

Model	FNR100N-10	FNR100V-10	FNR101N-10	FNR101V-10
Tank capacity	1.1 L		1.8 L	
Port size	Rc1			
Operating pressure	Max. 1.0 MPa			
Fluid temperature	Max. 80°C			
Material	Bowl & Cover			
	Stainless steel 304			
Material	O-ring		O-ring	
	NBR		FKM	
Weight	1.5 kg		1.9 kg	
Applicable filter	FN11□1□ (Element L 250)		FN11□2□ (Element L 500)	

Dust recovery filter (produced upon receipt of order)

This filter is for recovering dust from fluid after element back-flushing.

It enables re-use of the element (gold mesh).



How to Order

RoHS

FND100 N - 10 - M 149 X0

Seal material

Symbol	Material
N	NBR
V	FKM

Nominal filtration rating

Symbol	Nominal filtration rating
149	149 μm

Element type

Symbol	Type
M	Gold mesh

Port size

Symbol	Port size
10	R1

Specifications

Model	FND100N-10-M149X0	FND100V-10-M149X0
Port size	R1	
Operating pressure	Max. 0.7 MPa	
Fluid temperature	Max. 80°C	
Material	Bowl & Cover	
	Stainless steel 304	
Material	O-ring	
	NBR	FKM
Material	Element	
	Stainless steel 304	
Element nominal filtration rating	149 μm	
Weight	7.5 kg	

Note) Produced upon receipt of order.

FGD
FGE
FGG
FGA
FGC
FGF
FGH
FQ1
FN
EB□
ES□

FN1/FN4 Series

Flow Rate Characteristics (Initial Value)

- Test fluid: Tap water ● Liquid temperature: 17 to 20°C (Room temperature)
- Test method: Per SMC test method

Element Length

250 L / FN1□□-10-S□□

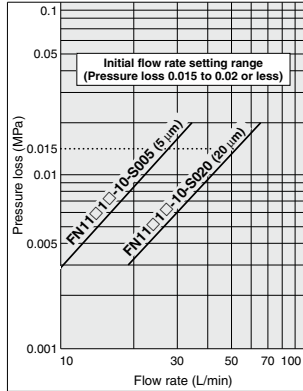

Element Length

500 L / FN1□2□-10-S□□

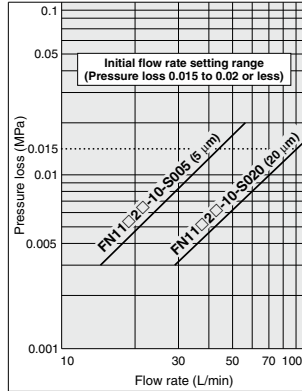

Element Length

500 L / FN41□2□-20-S□□

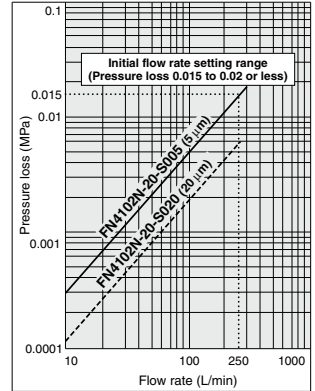

Filtration Characteristics

- Fluid: Tap water ● Flow rate: 20 L/min ● Liquid temperature: Room temperature ● Test dust: AC course
- Test method: Per SMC test method

5 μm

FN11□□□-10-S005

FN41□2□-20-S005

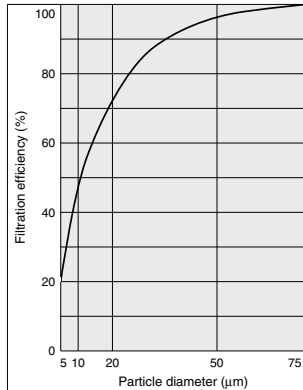

20 μm

FN11□□□-10-S020

FN41□2□-20-S020

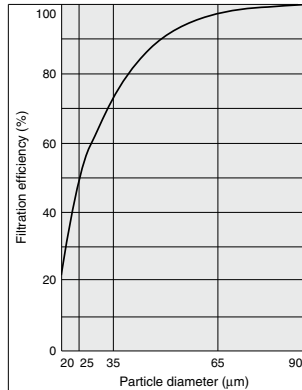

Blocking Characteristics (Repeatability)

- Fluid: Tap water ● Supply pressure: 0.2 MPa ● Flow rate: 20 L/min ● Test dust: AC course test dust
- Test method: Per SMC test method
- Filter part no.: **FN1101N-10-S□**, **FN4102N-20-S□**
- Element: **END100-020** (Cylindrical type, 20 μm)

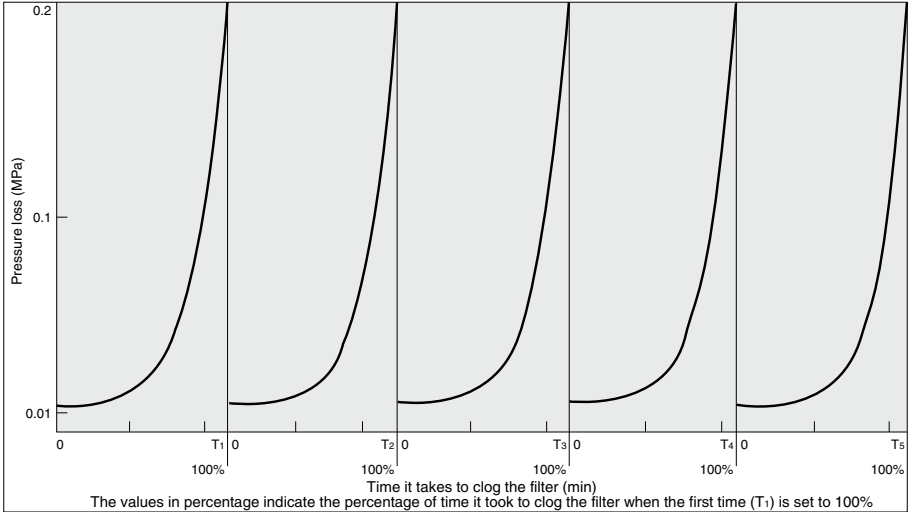

Introduce a certain concentration of dust and back-flush the filter when the pressure loss reaches 0.2 MPa. Repeat filtering and back-flushing process (up to five times shown in the graphs).

The graphs above show that the initial pressure loss ($\Delta P = 0.015$ MPa) and time it takes to reach the pressure loss of $\Delta P = 0.2$ MPa return to the rough initial value even after repeated back-flushing.

Measurement Circuit

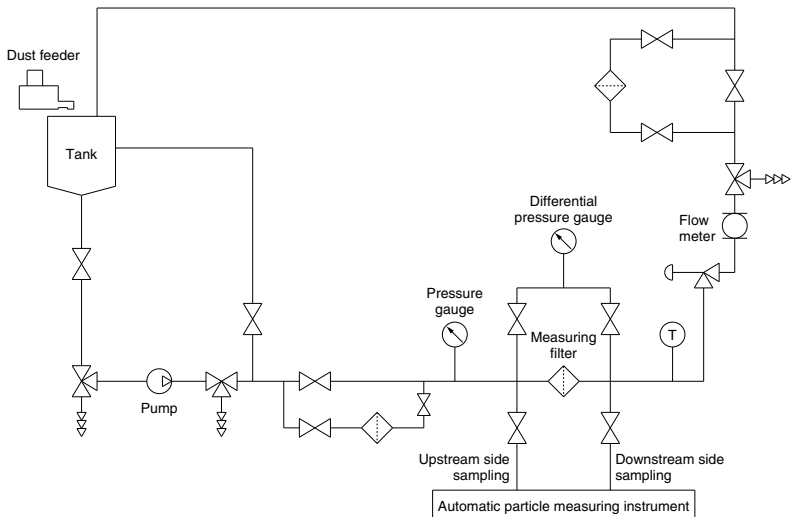

FGD
FGE
FGG
FGA
FGC
FGF
FGH
FQ1
FN
EB□
ES□

FN1/FN4 Series

Piping Example

FN1/FN4 Series Low Maintenance Filter cannot be used alone.

Please follow the component configuration and operation steps illustrated below.

FN1

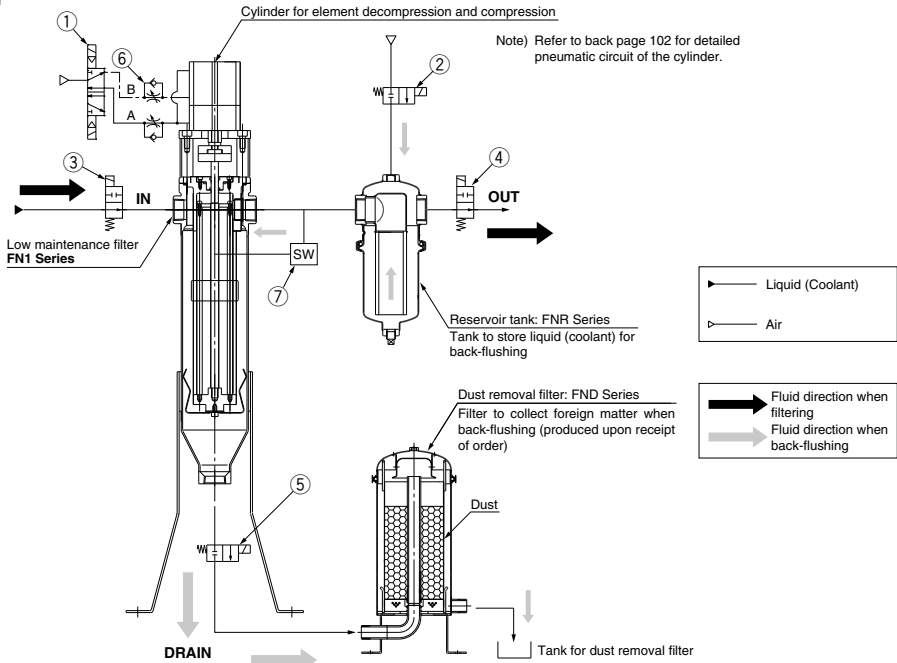

Example of Connection Device The products indicated in the table below refer to coolant related products. The SGC and VNC series coolant valves (with bodies made of cast iron) cannot be used with any fluids (such as industrial water) other than coolant.

No.	Description	Device	No.	Description	Device
1	Cylinder driving valve	5-port solenoid valve	5	Drain valve	Coolant valve
2	Air supply valve	Process valve	6	Speed controller	Speed controller
3	IN side valve	Coolant valve	7	Differential pressure switch	Differential pressure switch
4	OUT side valve	Coolant valve			Differential pressure controller

Series inside () indicate SMC products.

Note) Please check the fluid compatibility with each device when selecting connection device.

Actuation example

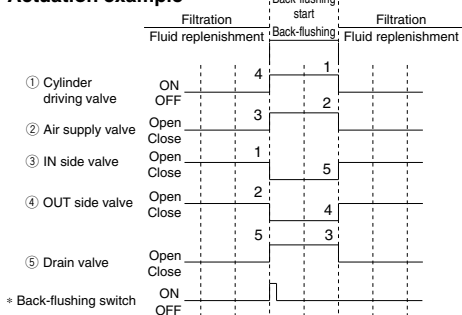

* The M/C stop signal and a signal for element clogging (differential signal switch) are used to start back-flushing. Numbers in the chart indicate the order for each operation.

Step	Operation description
When back-flushing	1 ③ IN side valve: Close Stops fluid supply to the filter.
	2 ④ OUT side valve: Close Seals the filter and reservoir tank containing fluid.
	3 ② Air supply valve: Open Supplies the fluid in the reservoir tank to the filter.
	4 ① Cylinder driving valve: ON Lowers the cylinder to decompress the element.
	5 ⑤ Drain valve: Open The fluid in the reservoir tank passes through the decompressed element and forces out to the tank.
When filtering	1 ① Cylinder driving valve: OFF Raises the cylinder to compress the element.
	2 ② Air supply valve: Close Stops pressure feed.
	3 ⑤ Drain valve: Close
	4 ④ OUT side valve: Open
	5 ③ IN side valve: Open

FN4

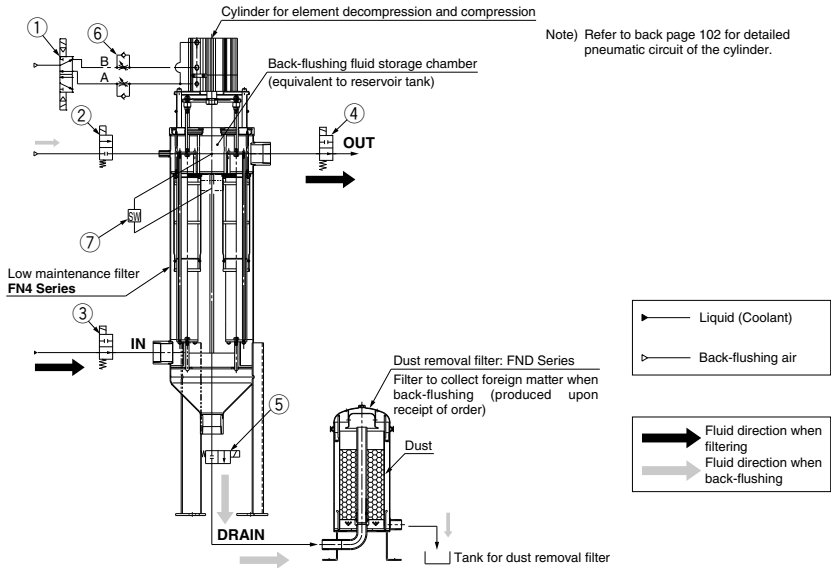

The products indicated in the table below refer to coolant related products. The SGC and VNC series coolant valves (with bodies made of cast iron) cannot be used with any fluids (such as industrial water) other than coolant.

No.	Description	Device	No.	Description	Device
1	Cylinder driving valve	5-port solenoid valve	5	Drain valve	Coolant valve
2	Air supply valve	Process valve	6	Speed controller	Speed controller
3	IN side valve	Coolant valve	7	Differential pressure switch	Differential pressure switch
4	OUT side valve	Coolant valve			Differential pressure controller

Series inside () indicate SMC products.

Note) Please check the fluid compatibility with each device when selecting connection device.

Caution

1. Cylinder for element decompression and compression

- Do not overthrottle the speed controller when adjusting the cylinder retraction speed (element decompression). If the element is decompressed too slowly, the back-flushing may become ineffective.
- Refer to back page 102 for "Cylinder for element decompression and compression" regarding the detailed pneumatic circuit of the cylinder and lock.

2. Reservoir tank installation

- Installation of a reservoir tank (optional) is recommended to store fluid for back-flushing. If a reservoir tank is not going to be installed, make sure to allow piping capacity equivalent to a size of reservoir between the low maintenance filter and air supply valve.
The FN4 series is equipped with a back-flushing fluid storage chamber equivalent to a reservoir tank, so there is no need to install an optional reservoir tank.

3. Air pressure

- Set the pressure of the air supply valve to 0.25 to 0.3 MPa. Increasing the pressure will not improve the back-flushing effect.
- Use the same set pressure for the supply pressure of the lock cylinder. Exceeding this pressure range may increase the load applied to the filtering plate when the element is compressed, causing malfunction.

4. IN side circuit

- Devise the by-pass circuit on the upstream side of IN side valve to prevent the line pressure during back-flushing from rising and to protect the pump.

5. Others

- The filter should be back-flushed until the differential pressure reaches 0.1 MPa to avoid a drop in the flow rate due to the element clogging and to maintain back-flushing efficiency.
- Time it takes to clog the element varies depending on the dust condition. Monitor the clogging condition of the element using a detection switch for differential pressure.
- Since the element of this low maintenance filter provides rough filtration efficiency (with current notch wire level), it can be used as a pre-filter to extend the life of the check filter depending on the fluid condition in use.
Installing these low maintenance filters side by side to use them alternately enables continuous operation during back-flushing. Use an element with 500 mm in length for highly contaminated fluid. A sufficient flow rate can be ensured by installing two to three low maintenance filters in a row in case of the insufficient flow capacity.

FGD

FGE

FGG

FGA

FGC

FGF

FGH

FQ1

FN

EB

ES

FN1/FN4 Series

Construction

FN11□1□-10-S□□□□

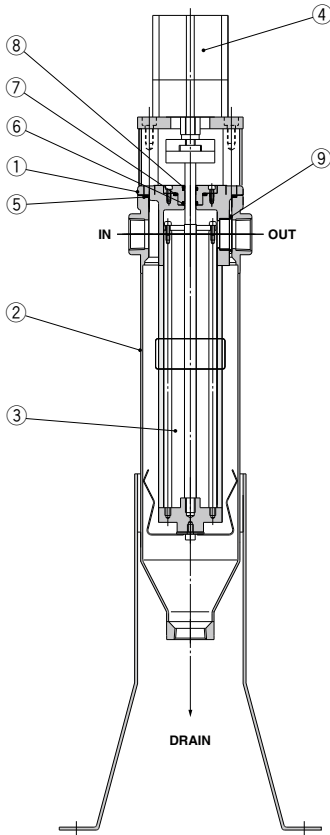

FN11□2□-10-S□□□□

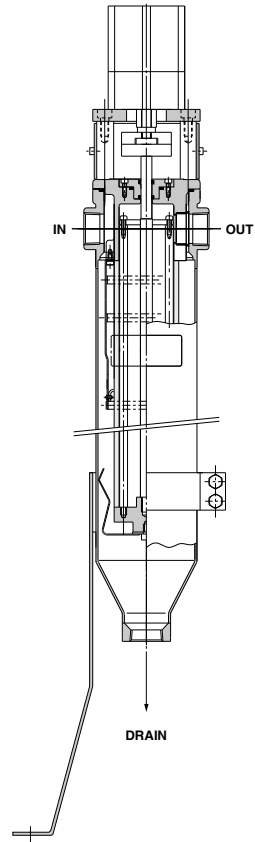

Component Parts

No.	Description	Material	Note
1	Cover	SCS13	
2	Bowl	SCS13	
3	Element	Stainless steel 304	ø65 x 250 L ø65 x 500 L
4	Compact cylinder with lock	FN11□1	CDLQB63-30D-F
		FN11□2	CDLQB63-50D-F

Replacement Parts

No.	Description	Quantity	Material
5	O-ring	1	NBR or FKM
6	Penta seal	1	
7	O-ring	1	
8	Scraper	1	
9	O-ring	1	

Replacement Element

Model	Order no.	Quantity	Note
FN11□1□	END100-005	1	5 μm, Cylindrical type
	END100-020	1	20 μm, Cylindrical type
	END110-005	1	5 μm, Step type
FN11□2□	END200-005	1	5 μm, Cylindrical type
	END200-020	1	20 μm, Cylindrical type
	END210-005	1	5 μm, Step type

Replacement Parts: Seal Kit

Model	Order no.	Material	Note
FN11□□N	KT-FN11N	NBR	Items ⑤ through ⑨ from the above chart, 1 pc. each
FN11□□V	KT-FN11V	FKM	

Construction

FN4102□-20-S□

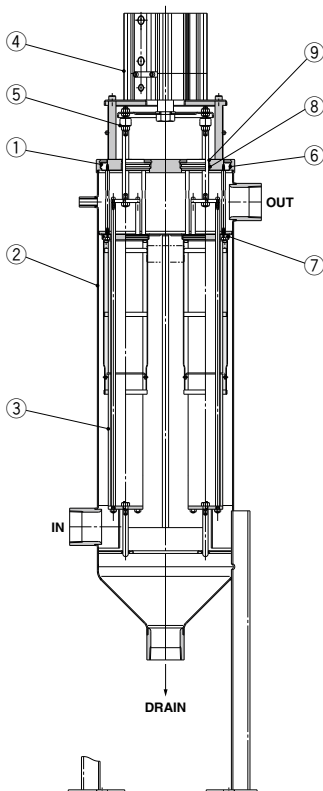

FGD

FGE

FGG

FGA

FGC

FGF

FGH

FQ1

FN

EB□

ES□

Component Parts

No.	Description	Note
1	Cover	
2	Bowl	
3	Element	φ65 x 500 L
4	Compact cylinder with lock	CDLQA100-50D-F
5	Floating joint	JA20-8-125

Replacement Parts

No.	Description	Quantity	Material
6	O-ring	4	NBR or FKM
7	O-ring	4	
8	Penta seal	4	
9	Scraper	4	

Replacement Element

Model	Order no.	Quantity	Note
FN4102□	END400-005	4	5 μm
	END400-020	4	20 μm

Replacement Parts: Seal Kit

Model	Order no.	Material	Note
FN4102N	KT-FN41N	NBR	Items ⑥ through ⑨ from the above chart, 1 pc. each
FN4102V	KT-FN41V	FKM	

FN1/FN4 Series

Dimensions: FN1

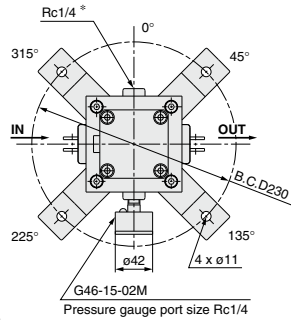

Note) Use the Rc1/4 port marked with an asterisk when designing an air release circuit.

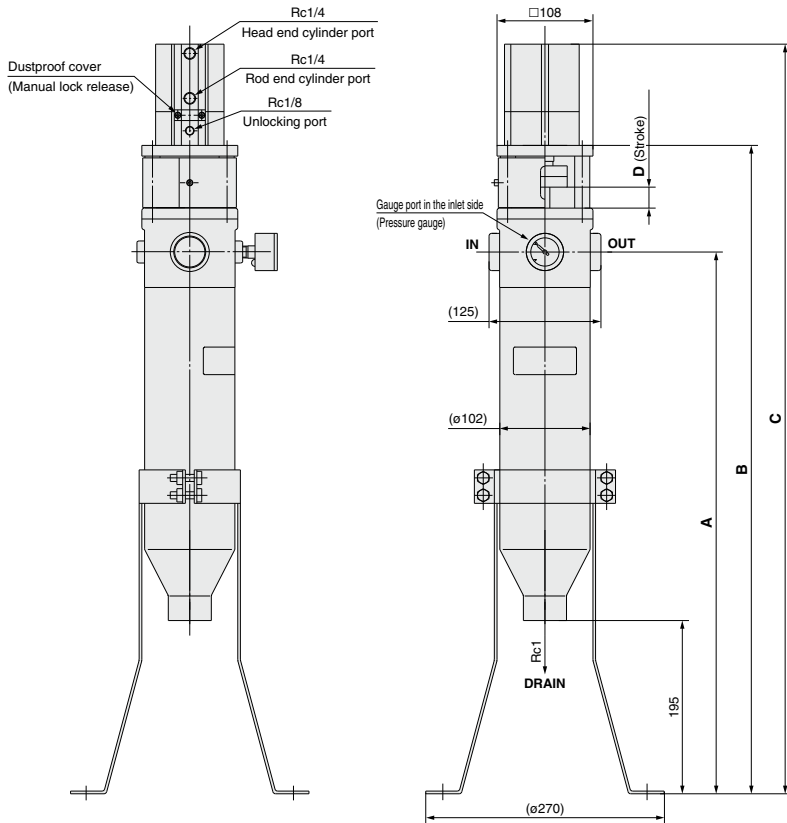

Dimensions

(mm)

Model	Port size (Nominal size B)	A	B	C	D
FN11□1	Rc1	610	(730)	(844)	20
FN11□2		860	(1000)	(1134)	40

Dimensions: FN4

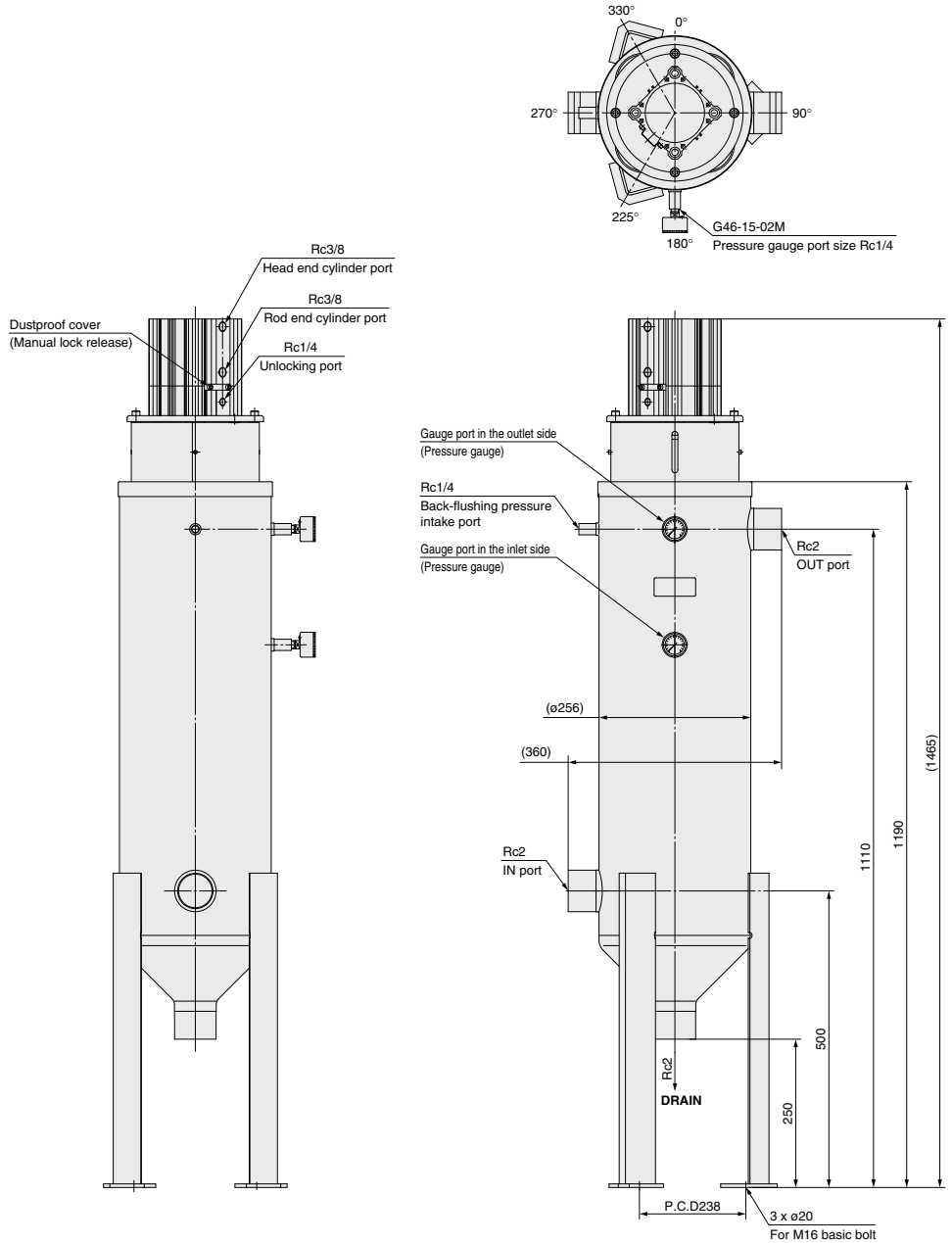

FGD
FGE
FGG
FGA
FGC
FGF
FGH
FQ1
FN
EB <input type="checkbox"/>
ES <input type="checkbox"/>

FN1/FN4 Series

Construction/Dimensions: Reservoir Tank, Dust Recovery Filter (Options, sold separately)

Reservoir tank (when using the FN1)

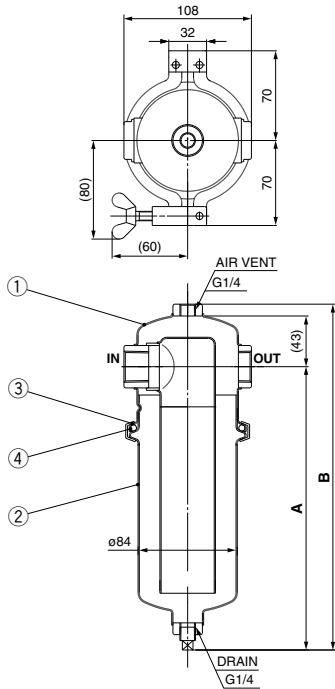

Dimensions

Model	Port size (Nominal size B)	(mm)	
		A	B
FNR100 _V -10	Rc1	204	(257)
FNR101 _V -10		332	(385)

Component Parts

No.	Description	Material	Note
1	Cover	Stainless steel 304	
2	Bowl	Stainless steel 304	
3	V-band	Stainless steel 304	

Replacement Parts

No.	Description	Material	Quantity	Note
4	O-ring	NBR	1	OR NBR-70-1 P85
		FKM	1	OR FKM-70 P85

Dust recovery filter

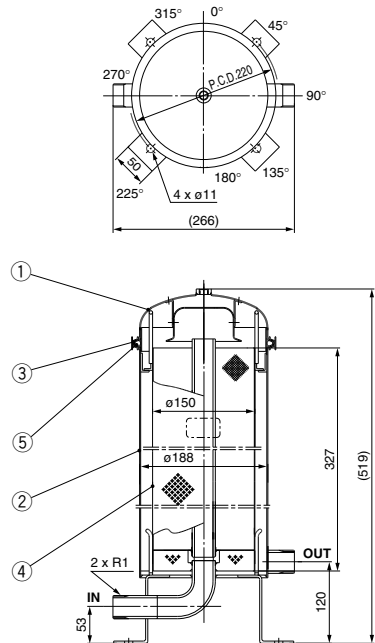

Component Parts

No.	Description	Material	Note
1	Cover	Stainless steel 304	
2	Bowl	Stainless steel 304	
3	V-band	Stainless steel 304	

Replacement Parts

No.	Description	Material	Quantity	Note
4	Element	Stainless steel 304	1	EZH710AS-149
5	O-ring	NBR	1	FGE-KT001
		FKM	1	FGE-KT002



FN1/FN4 Series

Specific Product Precautions 1

Be sure to read this before handling the products.
Refer to back page 50 for Safety Instructions.

Design

⚠ Caution

1. Do not operate exceeding the operating pressure range.
2. Do not operate exceeding the operating temperature range.
3. **Fluid**
Do not operate with gases.
4. **Fatigue failure**
Be sure to implement necessary measures for the following operating conditions:
 - 1) When surge pressure is applied to the element
 - 2) Unstable filter causes sliding or vibration.
 - 3) When the element repeatedly expands and shrinks due to thermal effect.
5. **Pressure drop**
Adjust the initial pressure drop to 0.02 MPa or less.
6. **Corrosion**
Corrosion may occur depending on the operating condition and environment.
The wetted part of the pressure gauge is made of brass. Confirm the compatibility with fluid in use.

Selection

⚠ Warning

1. For model selection, confirm application purpose, required specification, and operating condition (such as fluid, pressure, flow rate, temperature, and environment) so that the selected model is within the specified range.
2. Do not use at temperature that exceeds the boiling point of the fluid.
3. Never use with gases, including air.
4. Do not use in locations where pressure rises over 1 MPa due to water hammer or surge pressure.

Fluid

⚠ Warning

1. A low maintenance filter should be used for filtering coolant (oil-based or water-soluble), cutting oil, weak alkaline cleaning fluid, or industrial water. There may be circumstances where a seal or an O-ring deteriorates, causing leakage.
2. When fluid with high viscosity such as oil is used, the differential pressure increases, causing the flow rate to decrease. Please thoroughly check the applicability of the fluid to decide whether it is used.

Piping

⚠ Caution

1. Ensure sufficient clearance for maintenance when piping.
2. Before piping is connected, it should be thoroughly flushed out with air or water to remove chips, cutting oil, and other debris.
3. Before piping is connected, confirm IN and OUT sides.
4. **Connection**
When screwing together pipes and fittings, be certain that chips from the pipe threads and sealing material do not get inside the piping.
Also, when sealant tape is used, leave 1.5 to 2 thread ridges exposed at the end of the male threads.
5. **Line flushing**
Flush the piping lines at the time of initial use and when replacing the element.
6. **Connect piping to prevent rise of line pressure on the IN side at the time of back-flushing.**
7. When starting normal operation after back-flushing, release residual pressure in the filter to completely replace the air with the fluid.

Operating Environment

⚠ Caution

1. Discoloration or material deterioration may occur in an atmosphere where there is a possibility of corrosion.
As a corrosion advances, the filter will lose its function.
2. When the filter used in locations where there is a vibration or impact, fatigue failure may occur.
Provide proper reinforcement for operation.

Maintenance

⚠ Caution

1. The pressure drop fluctuates depending on operating conditions. Since the pressure drop is one of the factors indicating filter characteristics, set a control standard for the filter.
2. Be sure to conduct a back-flush to prevent dust adhesion before operation stop (pause).
3. If it is necessary to remove the element for cleaning or to replace the element, refer to the disassembly and assembly instructions in the operating manual for the product when performing maintenance.

FGD

FGE

FGG

FGA

FGC

FGF

FGH

FQ1

FN

EB

ES



FN1/FN4 Series Specific Product Precautions 2

Be sure to read this before handling the products.
Refer to back page 50 for Safety Instructions.

<Cylinder for element decompression and compression>

Pneumatic Circuit

⚠ Warning

- Do not use 3-position valves.**
Unlocking pressure may unlock the lock.
- Use a speed controller with meter-out control.**
Malfunction may occur if meter-in control is used.
- Be careful of backflow of pressure exhausted from a common exhaust type valve manifold.**
A backflow of exhaust pressure may release the lock. Use an individual exhaust type manifold or single type valve.
- Split the pneumatic piping for the lock unit between the cylinder and the speed controller.**
Splitting the piping outside of these 2 components may shorten a service life.
- Keep the piping of the lock unit from the branching short.**
Long piping can cause malfunctioning of unlocking and shorten a service life of the lock.

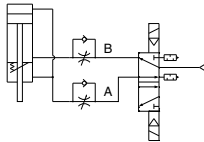

Manual Lock Release

⚠ Warning

- Follow the steps shown below for manual release after confirming safety.**

Make sure that there will be no danger even when the load moves suddenly. Also, confirm that no personnel is present in the movement range of the load.

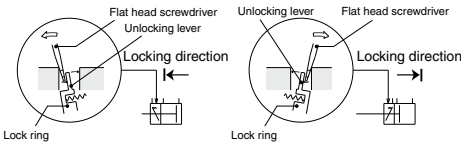

Extension locking

- Remove the dustproof cover.
- As shown above, insert a flat head screwdriver in the clearance of the rod end of the manual lock release lever. Tilt the driver slightly toward the direction indicated by the arrow (to the rod end) to release the lock.

Retraction locking

- Remove the dustproof cover.
- As shown above, insert a flat head screwdriver in the clearance of the head end of the manual lock release lever. Tilt the driver slightly toward the direction indicated by the arrow (to the head end) to release the lock.

<Floating joint for element coupling> (FN4)

Mounting

⚠ Warning

- When screwing a male rod into the female thread in a socket or bowl, do not contact with the bottom.**
If the rod is screwed in all the way so that it touches the bottom, the stud will not be able to float and damage will result. Screw in the rod to a position one or two turns before the point at which it would make contact with the bottom.
- Remove the dust cover before screwing a stud, socket, or bowl into the driven body. If they are screwed in without removing the dust cover, the dust cover could be damaged.**
- When connecting the driven body and cylinder rod with a floating joint, make sure to secure them using the appropriate tightening torque for the thread size. If there are concerns regarding loosening during use, use pin stoppers or adhesive to prevent loosening.**
When the connection loosens and come undone, the driven body could run out of control or fall, possibly damaging or destroying the equipment.
- The floating joint is not a shaft fitting designed for rotation, and it should not be used for that purpose.**

Maintenance

⚠ Warning

- Do not disassemble and reuse the floating joint.**
A very strong adhesive has been applied to the threaded coupling portion to prevent it from being disassembled. Disassembling it by force could damage it.