

<Full SiC Power Modules>

FMF400BXZ-24B

HIGH POWER SWITCHING USE
INSULATED TYPE



fourpack

Drain current I_D **400 A**
 Drain-Source voltage V_{DSX} **1200 V**
 Maximum junction temperature T_{vjmax} **175 °C**

- Silicon Carbide MOSFET + Silicon Carbide Schottky Barrier Diode
- Flat base Type
- Copper base plate
- RoHS Directive compliant
- Recognized under UL1557, File E323585

APPLICATION

AC Motor Control, Motion/Servo Control, Power supply, etc.

OUTLINE DRAWING & INTERNAL CONNECTION

Dimension in mm

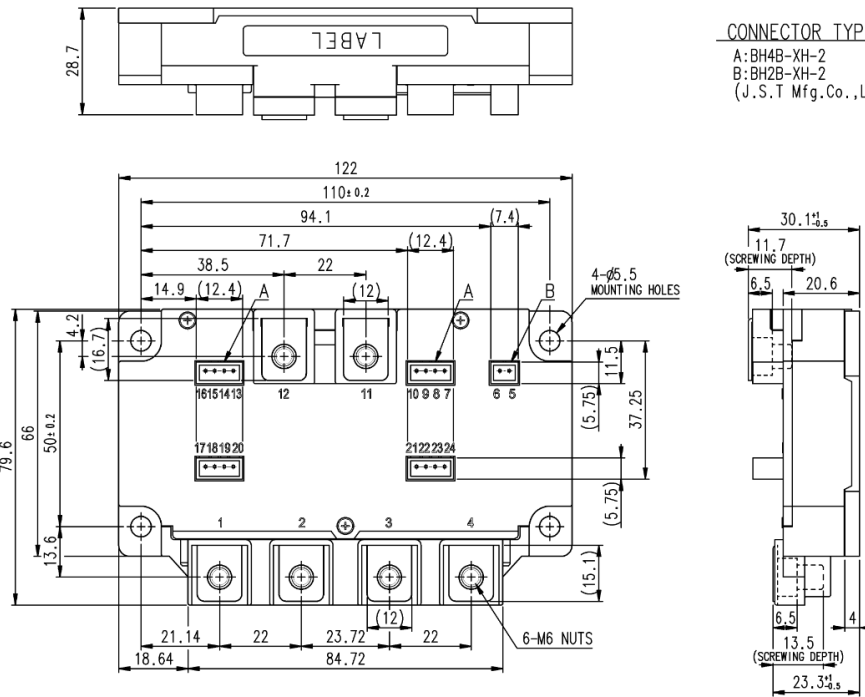

CONNECTOR TYPE
 A: BH4B-XH-2
 B: BH2B-XH-2
 (J.S.T Mfg.Co.,LTD.)

INTERNAL CONNECTION

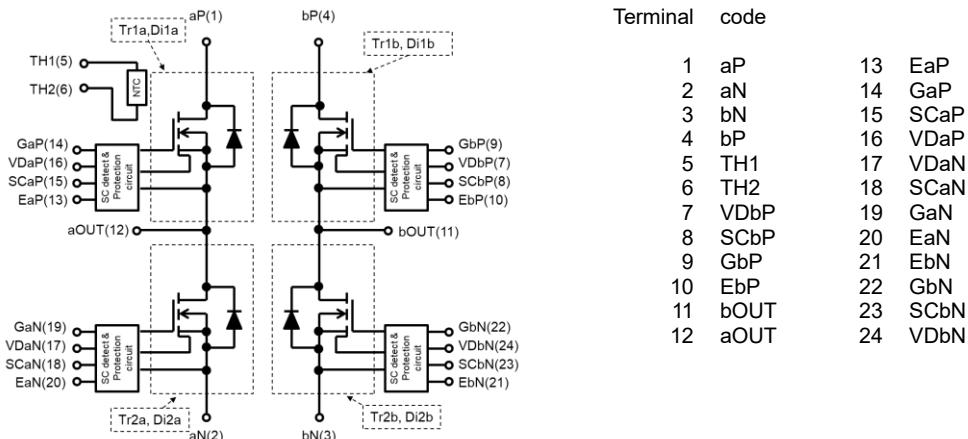

Tolerance otherwise specified

Division of Dimension	Tolerance
0.5 to 3	±0.2
over 3 to 6	±0.3
over 6 to 30	±0.5
over 30 to 120	±0.8
over 120 to 400	±1.2

FMF400BXZ-24B

HIGH POWER SWITCHING USE
INSULATED TYPE

MAXIMUM RATINGS (T_{vj} =25 °C, unless otherwise specified)

Symbol	Item	Conditions	Rating	Unit
V _{DSX}	Drain-source voltage	V _{GS} =-15 V	1200	V
V _{GSS}	Gate-source voltage	D-S short-circuited	±20	V
I _D	Drain current	DC, T _C =60°C (Note.2)	400	A
I _{DRM}		Pulse, Repetitive (Note.3), T _{vj} =150°C(Notes.4)	600	
P _{tot}	Total power dissipation	T _C =25 °C (Note. 2)	1560	W
I _S (Note.1)	Source current	DC	400	A
I _{SRM} (Note.1)		Pulse, Repetitive (Note.3), T _{vj} =150°C	600	
V _{iso1}	Isolation voltage	Terminals to base plate, RMS, f=60 Hz, AC 1 min	5000	V
T _{vjmax}	Maximum junction temperature	Instantaneous event (overload) (Note.10)	175	°C
T _{vjop}	Operating junction temperature	Continuous operation (under switching) (Note.10)	-40~+150	°C
T _{cmax}	Maximum case temperature	(Note.2, 10)	125	°C
T _{stg}	Storage temperature	-	-40~+125	°C

ELECTRICAL CHARACTERISTICS (T_{vj}=25 °C, unless otherwise specified)

Symbol	Item	Conditions (note9)	Limits			Unit	
			Min.	Typ.	Max.		
I _{DSX}	Drain-source cut-off current	V _{DS} =V _{DSX} , V _{GS} =-15 V	-	-	4	mA	
		V _{DS} =800V, V _{GS} =-15 V	-	-	0.4		
V _{GS(th)}	Gate-source threshold voltage	I _D =113mA, V _{DS} =10 V	1.8	2.5	3.2	V	
I _{GSS}	Gate-source leakage current	V _{GS} =V _{GSS} , D-S short-circuited	-	-	0.5	µA	
V _{DS(on)} (terminal)	Drain-source on-state voltage	I _D =400 A, V _{GS} =15V (Note.6)	T _{vj} =25 °C	-	1.65	2.30	V
			T _{vj} =125 °C	-	2.10	-	
			T _{vj} =150 °C	-	2.20	-	
V _{DS(on)} (chip)	Drain-source on-state voltage	I _D =400 A, V _{GS} =15V (Note.6)	T _{vj} =25 °C	-	1.35	-	V
			T _{vj} =125 °C	-	1.80	-	
			T _{vj} =150 °C	-	1.90	-	
r _{DS(on)} (chip)	Drain-source on-state resistance	I _D =400 A, V _{GS} =15V (Note.6)	T _{vj} =25 °C	-	3.4	-	mΩ
			T _{vj} =125 °C	-	4.5	-	
			T _{vj} =150 °C	-	4.8	-	
C _{iss}	Input capacitance	V _{DS} =10 V, V _{GS} =0V	-	34	-	nF	
C _{oss}	Output capacitance		-	24	-		
C _{rss}	Reverse transfer capacitance		-	1.7	-		
Q _G	Gate charge	V _{DD} =600 V, I _D =400 A, V _{GS} =0→15 V	-	975	-	nC	
t _{d(on)}	Turn-on delay time	V _{DD} =600 V, I _D =400 A, V _{GS} =±15 V, T _{vj} =150°C, R _G =3.0Ω, L _{s_ext} =25nH, Inductive load, per pulse	-	120	-	ns	
t _r	Rise time		-	80	-		
t _{d(off)}	Turn-off delay time		-	200	-		
t _f	Fall time		-	30	-		
E _{on}	Turn-on switching energy		-	16	-		mJ
E _{off}	Turn-off switching energy		-	7	-		
Q _C	Drain-source charge	-	2	-	µC		
V _{SD} (Note.1) (terminal)	Source-drain voltage	I _S =400 A(Notes.6) V _{GS} =-15 V	T _{vj} =25 °C	-	1.90	2.45	V
			T _{vj} =125 °C	-	2.70	-	
			T _{vj} =150 °C	-	2.90	-	
V _{SD} (Note.1) (chip)	Source-drain voltage	I _S =400 A (Notes.6) V _{GS} =-15 V	T _{vj} =25 °C	-	1.60	-	V
			T _{vj} =125 °C	-	2.40	-	
			T _{vj} =150 °C	-	2.60	-	
R _{DD'+SS'}	Internal lead resistance	aP-EaP, bP-EbP, aOUT-EaN, bOUT-EbN terminals, per switch	-	0.75	-	mΩ	
L _s	Internal stray inductance	aP-aN, bP-bN	-	18	-	nH	
r _g	Internal gate resistance	Per switch	-	1.75	-	Ω	

FMF400BXZ-24B

HIGH POWER SWITCHING USE
INSULATED TYPE

THERMAL RESISTANCE CHARACTERISTICS

Symbol	Item	Conditions	Limits			Unit
			Min.	Typ.	Max.	
$R_{th(j-c)Q}$	Thermal resistance ^(Note. 2)	Junction to case, per inverter switch	-	-	96	K/kW
$R_{th(j-c)D}$		Junction to case, per inverter FWD	-	-	126	
$R_{th(c-s)}$	Contact thermal resistance ^(Note.2)	Case to heat sink, per 1 module, Thermal grease applied ^(Note.8, 10)	-	12	-	K/kW

NTC THERMISTOR PART

Symbol	Item	Conditions	Limits			Unit
			Min.	Typ.	Max.	
R_{25}	Zero-power resistance	$T_C=25\text{ }^\circ\text{C}$ ^(Note.2)	4.85	5.00	5.15	kΩ
$\Delta R/R$	Deviation of resistance	$T_C=100\text{ }^\circ\text{C}$ ^(Note.2) , $R_{100}=493\text{ }\Omega$	-7.3	-	+7.8	%
$B_{(25/50)}$	B-constant	Approximate by equation ^(Note.7)	-	3375	-	K
P_{25}	Power dissipation	$T_C=25\text{ }^\circ\text{C}$ ^(Note.2)	-	-	10	mW

MECHANICAL CHARACTERISTICS

Symbol	Item	Conditions	Limits			Unit
			Min.	Typ.	Max.	
M_t	Mounting torque	Main terminals M 6 screw	3.5	4.0	4.5	N·m
M_s		Mounting to heat sink M 5 screw	2.5	3.0	6.0	
m	mass	-	-	500	-	g
d_a	Clearance	-	10	-	-	mm
d_s	Creepage distance	-	17	-	-	mm
e_c	Flatness of base plate	On the centerline X, Y ^(Note.5)	-100	-	+100	μm
-	Connector insertion force	2 pin type	0	-	25	N
-		4 pin type	0	-	35	N

*: This product is compliant with the Restriction of the Use of Certain Hazardous Substances in Electrical and Electronic Equipment (RoHS) directive 2011/65/EU and (EU)2015/863.

Note1. Represent ratings and characteristics of the anti-parallel, source-drain free wheeling diode (FWD).

- Case temperature (T_C) and heat sink temperature (T_s) are defined on the each surface (mounting side) of base plate and heat sink just under the chips. Refer to the figure of chip location.
- Pulse width and repetition rate should be such that the device junction temperature (T_{vj}) does not exceed T_{vjmax} rating.
- Junction temperature (T_{vj}) should not increase beyond T_{vjmax} rating.
- The base plate (mounting side) flatness measurement points (X, Y) are as follows of the following figure.

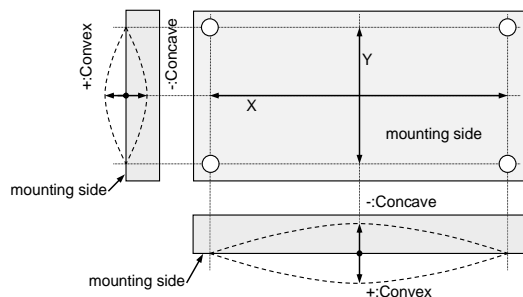

- Pulse width and repetition rate should be such as to cause negligible temperature rise.

$$7. B_{(25/50)} = \ln\left(\frac{R_{25}}{R_{50}}\right) / \left(\frac{1}{T_{25}} - \frac{1}{T_{50}}\right)$$

R_{25} : resistance at absolute temperature T_{25} [K]; $T_{25}=25\text{ }^\circ\text{C}+273.15=298.15$ [K]

R_{50} : resistance at absolute temperature T_{50} [K]; $T_{50}=50\text{ }^\circ\text{C}+273.15=323.15$ [K]

- Typical value is measured by using thermally conductive grease of $\lambda=0.9\text{ W/(m}\cdot\text{K)}/D_{(c-s)}=100\mu\text{m}$.
- Per switch
- Long term performance related to thermal conductive grease (including but not limited to aspects such as the increase of thermal resistance due to pumping out, etc.) should be verified under your specific application conditions. Each temperature condition (T_{vjmax} , T_{vjop} , T_{Cmax}) must be maintained below the maximum rated temperature throughout consideration of the temperature rise even for long term usage.

FMF400BXZ-24B

HIGH POWER SWITCHING USE
INSULATED TYPE

RECOMMENDED OPERATING CONDITIONS

Symbol	Item	Conditions	Limits			Unit
			Min.	Typ.	Max.	
V_{DD}	(DC) Supply voltage	Applied across aP -aN, bP-bN terminals	-	600	850	V
V_D	DC supply voltage (control)	Applied across VDaP-EaP, VDaN-EaN, VDbP-EbP, VDbN-EbN terminals	13.5	15.0	16.5	V
$V_{GS(+)}$	Gate-Source positive drive voltage	Applied across GaP-EaP, GaN-EaN, GbP-EbP, GbN-EbN terminals	13.5	15.0	16.5	V
$V_{GS(-)}$	Gate-Source negative drive voltage	Applied across GaP-EaP, GaN-EaN, GbP-EbP, GbN-EbN terminals	-16.5	-15.0	-7.0	V
R_G	External gate resistance (Note.11)	Per switch	3.0	-	15.0	Ω
f_c	Switching frequency	$V_{GS(+)}=15V, R_G=3.0\Omega,$	-	-	50	kHz
		$V_{DD}=600V, T_{vj}=150^\circ C$			100	
$t_{d(SCoff)}$	Gate cutoff delay time after SC output	$V_{GS}=15V, R_G=3.0\Omega, V_{DD}=600V, T_{vj}=150^\circ C$	-	-	3	μs

Note 11. The value of external gate resistance should be considered the surge voltage not to exceed the rating voltage in the worst system condition.

SHORT CIRCUIT DETECTION & PROTECTION CHARACTERISTICS

Symbol	Item	Conditions	Limits			Unit
			Min.	Typ.	Max.	
$I_{D(SC)}$	SC detect drain current	$T_{vj}=150^\circ C, V_{GS}=15V$	600	800	-	A
$t_{d(SC)}$	SC detect delay time	$T_{vj}=150^\circ C, V_{GS}=15V, R_G=3.0\Omega$	-	1	-	μs
$V_{GS(SC)}$	SC protection gate limit voltage	$T_{vj}=150^\circ C, V_{GS}=15V, R_G=3.0\Omega$	-	10.9	-	V
R1	SC protection gate limit resistance	-	-	6.2	-	Ω

Refer to the circuit in page.5

FMF400BXZ-24B

HIGH POWER SWITCHING USE
INSULATED TYPE

SHORT CIRCUIT DETECTION & PROTECTION

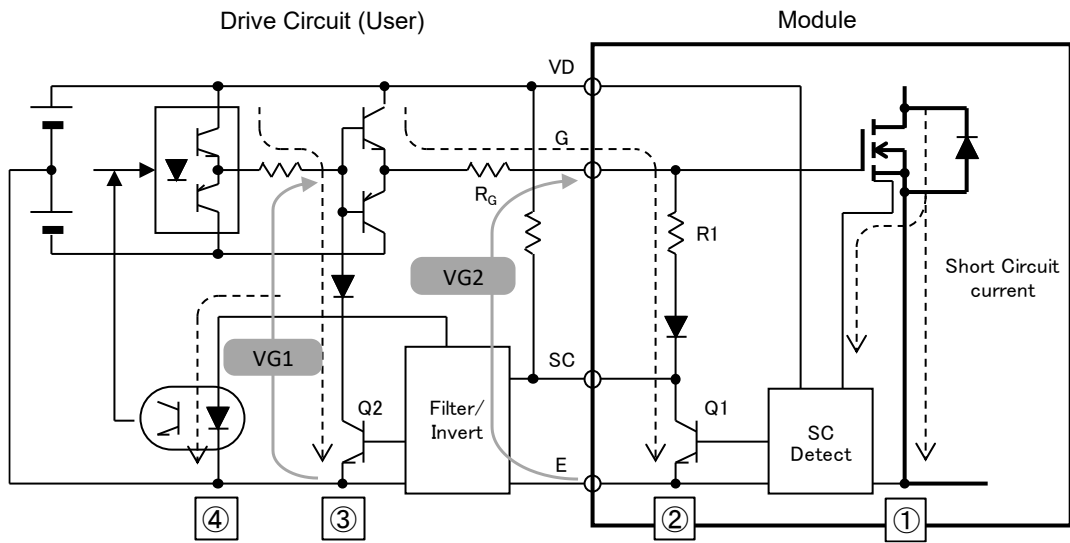

Example of application (Short circuit detection & protection)

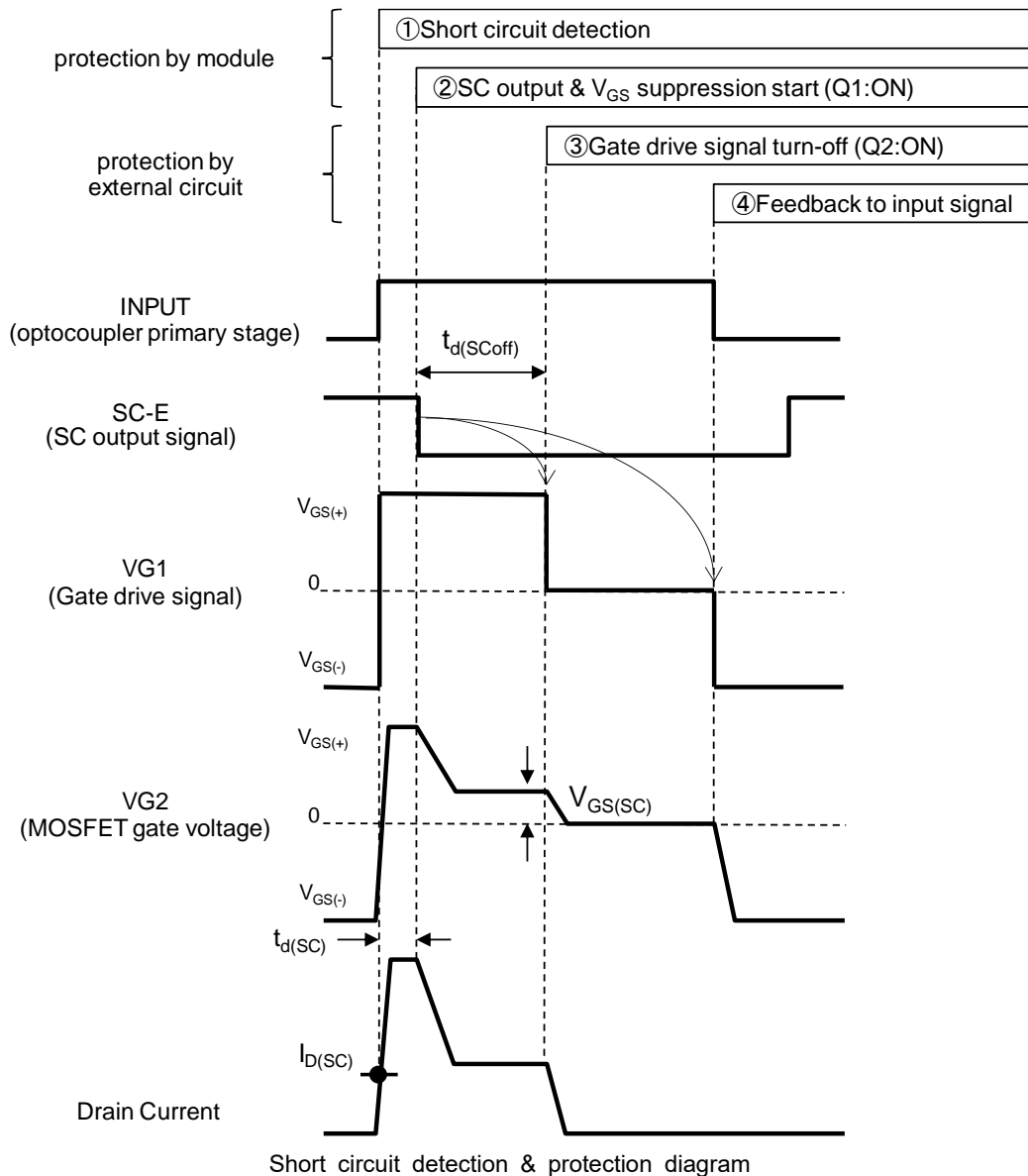

Short circuit detection & protection diagram

FMF400BXZ-24B

HIGH POWER SWITCHING USE
INSULATED TYPE

CHIP LOCATION (Top view)

Dimension in mm, tolerance: ± 1 mm

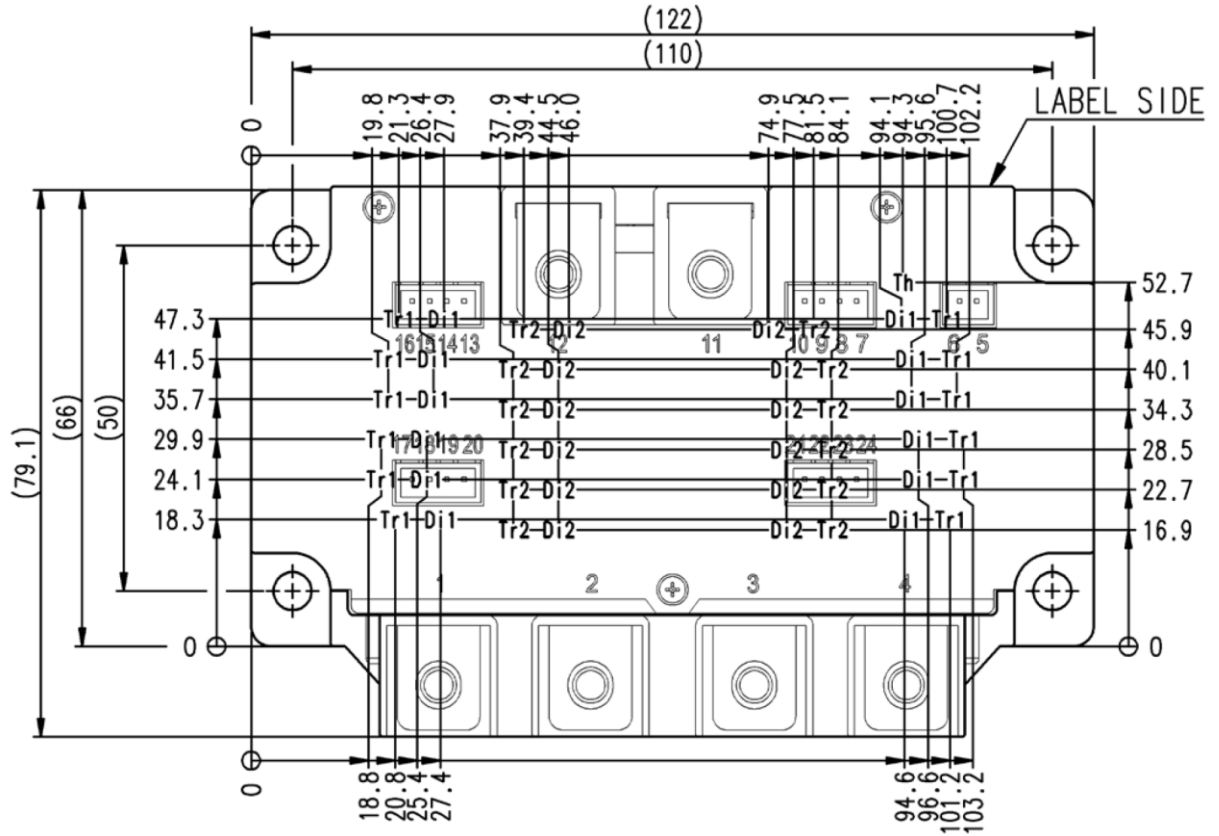

Tr1, Tr2: SiC-MOSFET, Di1, Di2: SiC-SBD, Th: NTC thermistor

FMF400BXZ-24B

HIGH POWER SWITCHING USE

INSULATED TYPE

TEST CIRCUIT AND WAVEFORMS

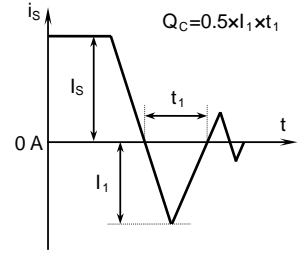
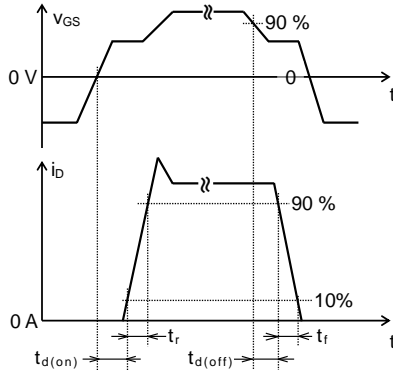
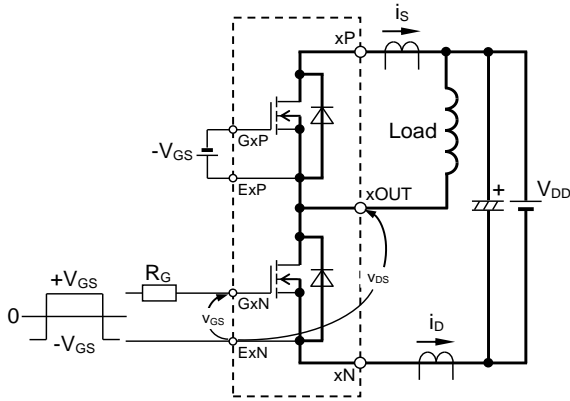

Switching characteristics test circuit and waveforms(x: a or b)

Qc test waveform

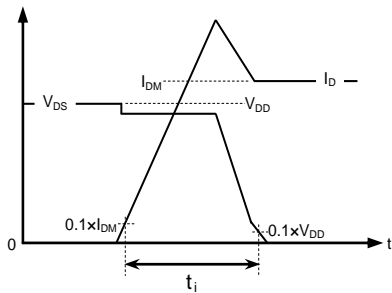

MOSFET Turn-on switching energy

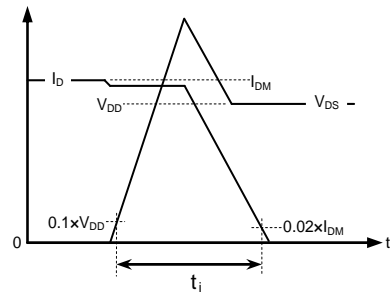

MOSFET Turn-off switching energy

Turn-on / Turn-off switching energy test waveforms (Integral time instruction drawing)

TEST CIRCUIT

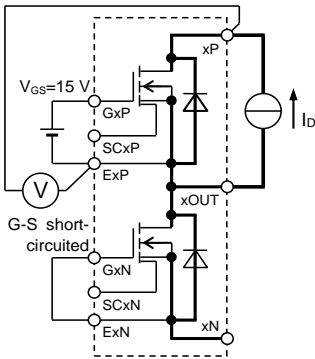

Tr1

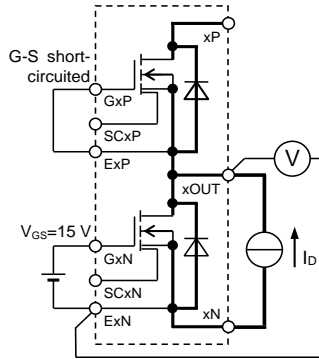

Tr2

V_{DS(on)} test circuit (x: a or b)

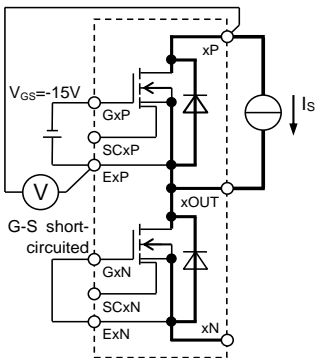

Di1

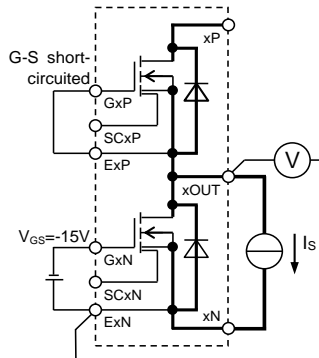

Di2

V_{SD} test circuit, V_{GS}=-15V (x: a or b)

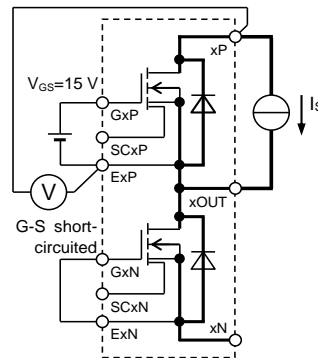

Tr1&Di1

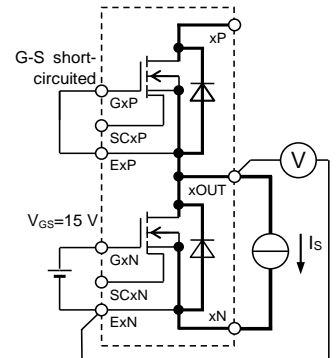

Tr2&Di2

V_{SD} test circuit, V_{GS}=15V (x: a or b)

FMF400BXZ-24B

HIGH POWER SWITCHING USE
INSULATED TYPE

PERFORMANCE CURVES

OUTPUT CHARACTERISTICS (TYPICAL)

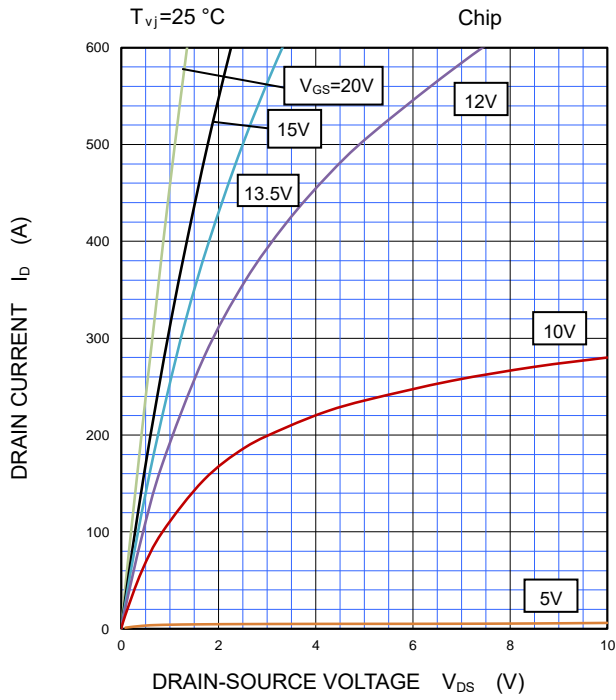

DRAIN-SOURCE ON STATE VOLTAGE CHARACTERISTICS (TYPICAL)

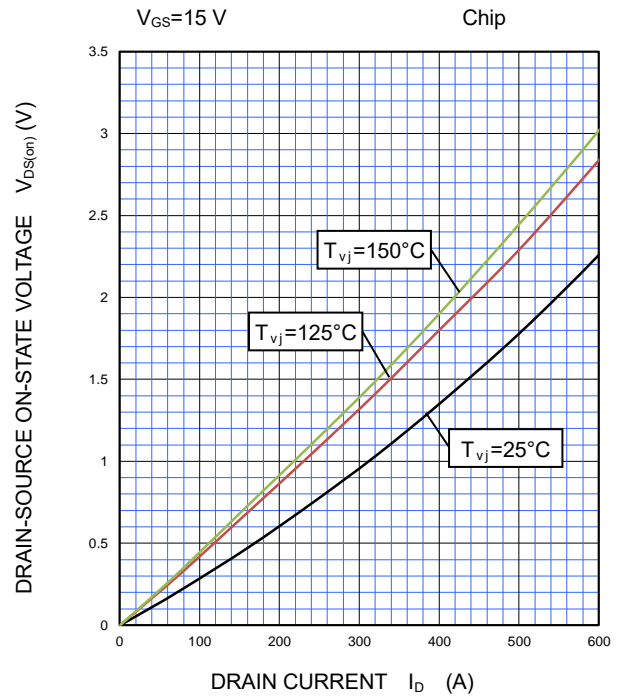

DRAIN-SOURCE ON STATE VOLTAGE CHARACTERISTICS (TYPICAL)

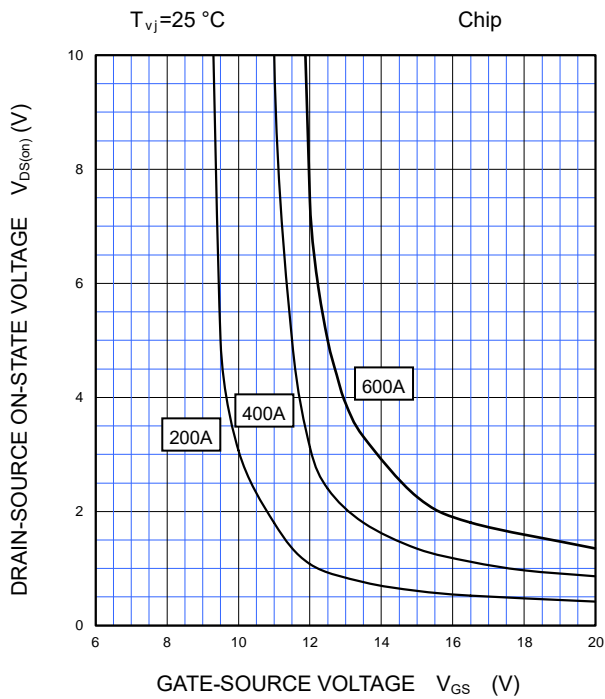

FMF400BXZ-24B

HIGH POWER SWITCHING USE
INSULATED TYPE

PERFORMANCE CURVES

FREE WHEELING DIODE
FORWARD CHARACTERISTICS
(TYPICAL)

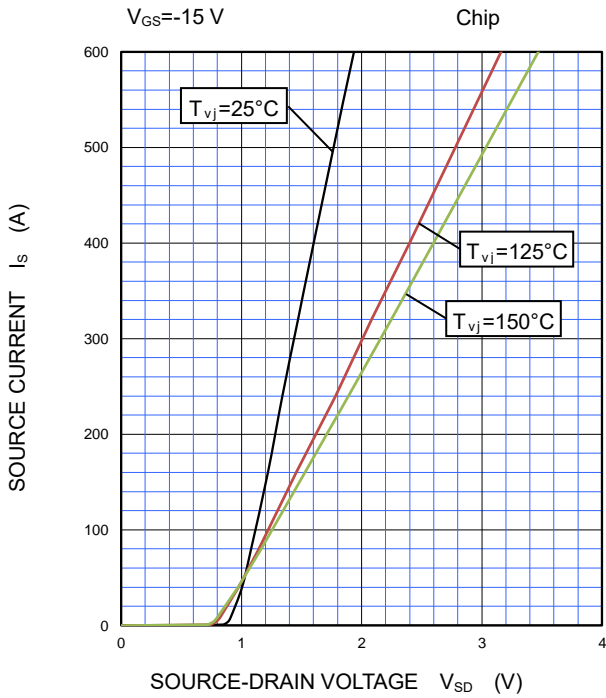

SOURCE-DRAIN ON STATE VOLTAGE
CHARACTERISTICS
(TYPICAL)

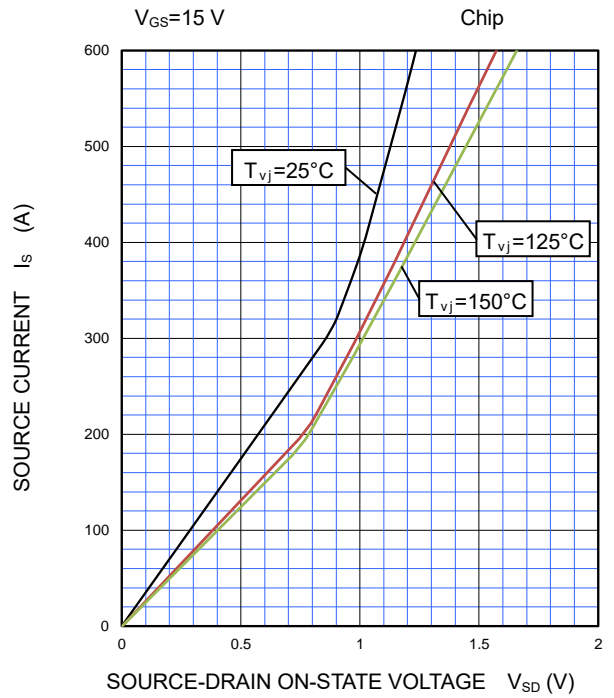

CAPACITANCE
CHARACTERISTICS
(TYPICAL)

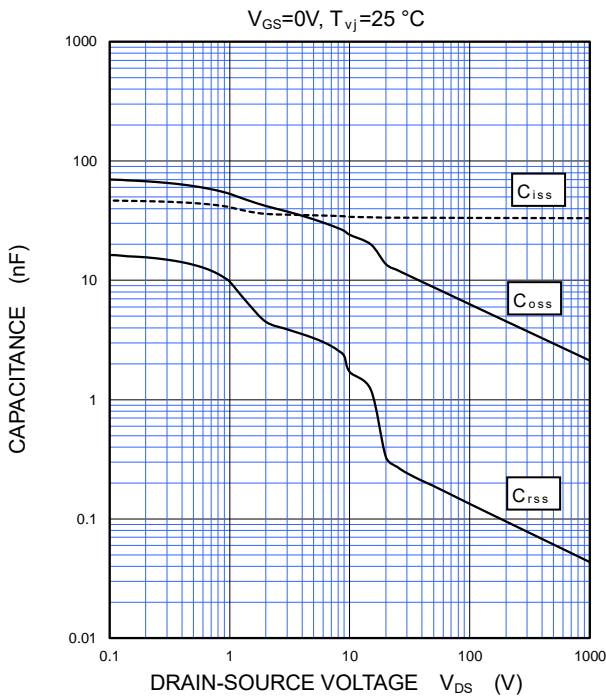

GATE CHARGE
CHARACTERISTICS
(TYPICAL)

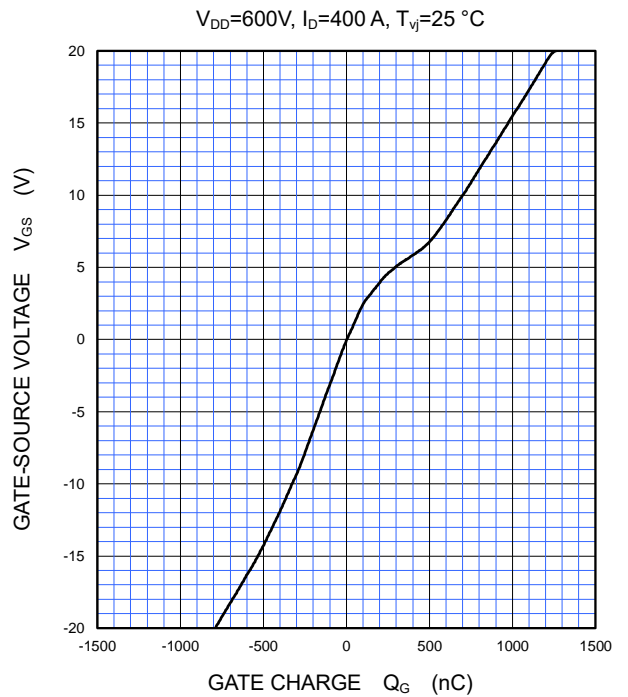

FMF400BXZ-24B

HIGH POWER SWITCHING USE
INSULATED TYPE

PERFORMANCE CURVES

HALF-BRIDGE
SWITCHING CHARACTERISTICS
(TYPICAL)

$V_{DD}=600\text{ V}$, $V_{GS}=\pm 15\text{ V}$, $R_G=3.0\Omega$, $L_{s_ext}=25\text{ nH}$
 $T_{vj}=150\text{ }^\circ\text{C}$, INDUCTIVE LOAD

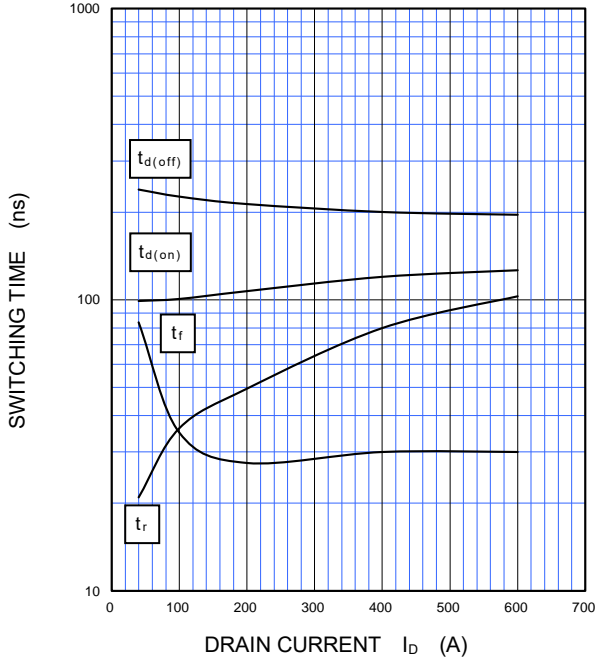

HALF-BRIDGE
SWITCHING CHARACTERISTICS
(TYPICAL)

$V_{DD}=600\text{ V}$, $V_{GS}=\pm 15\text{ V}$, $I_D=400\text{ A}$, $L_{s_ext}=25\text{ nH}$
 $T_{vj}=150\text{ }^\circ\text{C}$, INDUCTIVE LOAD

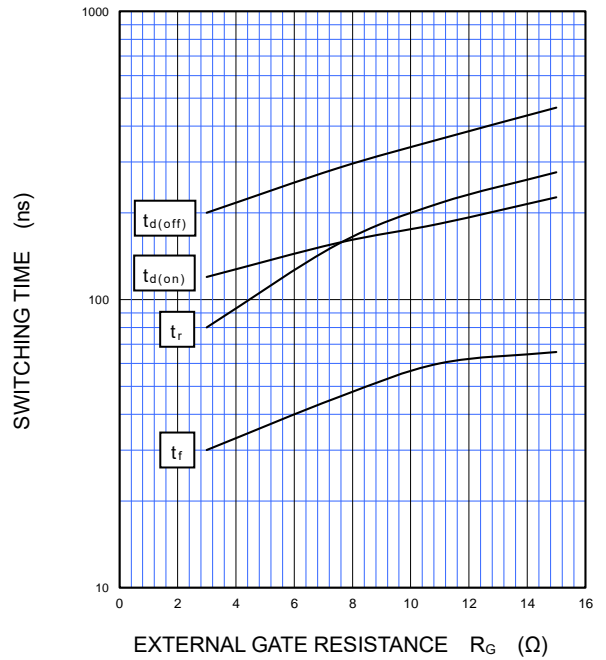

HALF-BRIDGE
SWITCHING CHARACTERISTICS
(TYPICAL)

$V_{DD}=600\text{ V}$, $V_{GS}=\pm 15\text{ V}$, $R_G=3.0\Omega$, $T_{vj}=150\text{ }^\circ\text{C}$, $L_{s_ext}=25\text{ nH}$
INDUCTIVE LOAD, PER PULSE

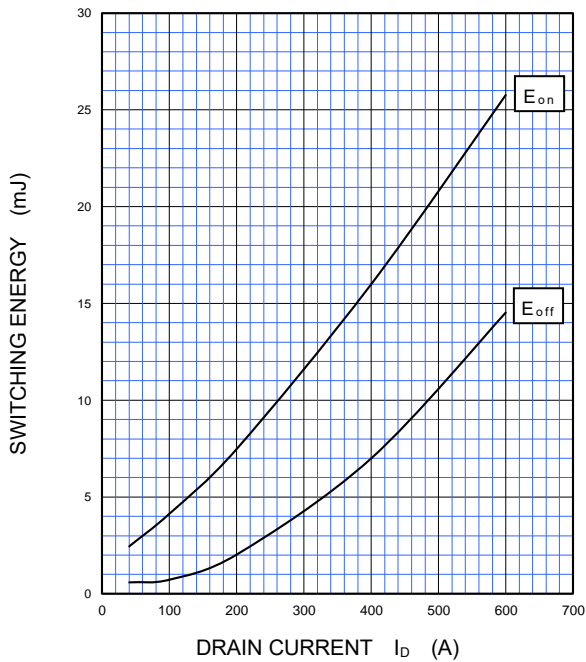

HALF-BRIDGE
SWITCHING CHARACTERISTICS
(TYPICAL)

$V_{DD}=600\text{ V}$, $V_{GS}=\pm 15\text{ V}$, $I_D=400\text{ A}$, $T_{vj}=150\text{ }^\circ\text{C}$, $L_{s_ext}=25\text{ nH}$
INDUCTIVE LOAD, PER PULSE

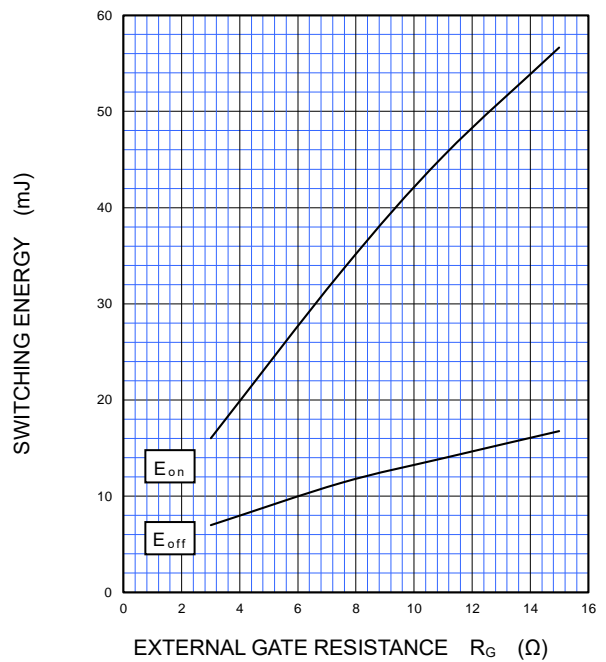

FMF400BXZ-24B

HIGH POWER SWITCHING USE
INSULATED TYPE

PERFORMANCE CURVES

TRANSIENT THERMAL IMPEDANCE
CHARACTERISTICS
(MAXIMUM)

Single pulse, $T_c=25\text{ }^\circ\text{C}$

$R_{th(j-c)Q}=96\text{K/kW}$, $R_{th(j-c)D}=126\text{K/kW}$

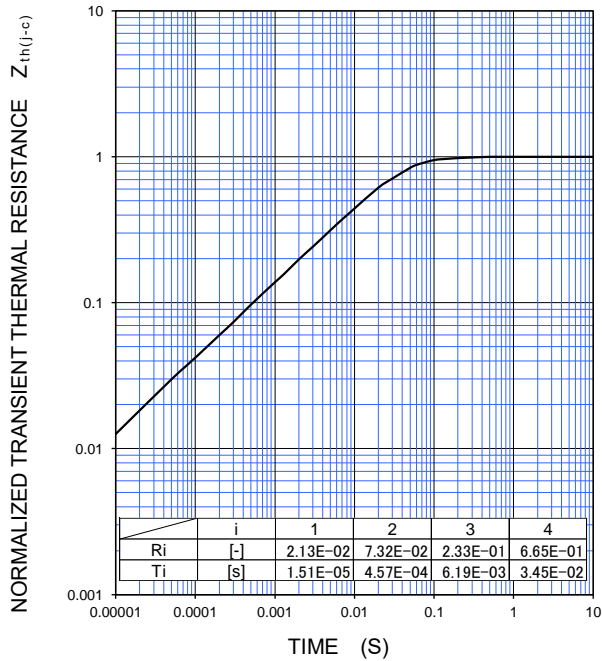

NTC thermistor part

TEMPERATURE
CHARACTERISTICS
(TYPICAL)

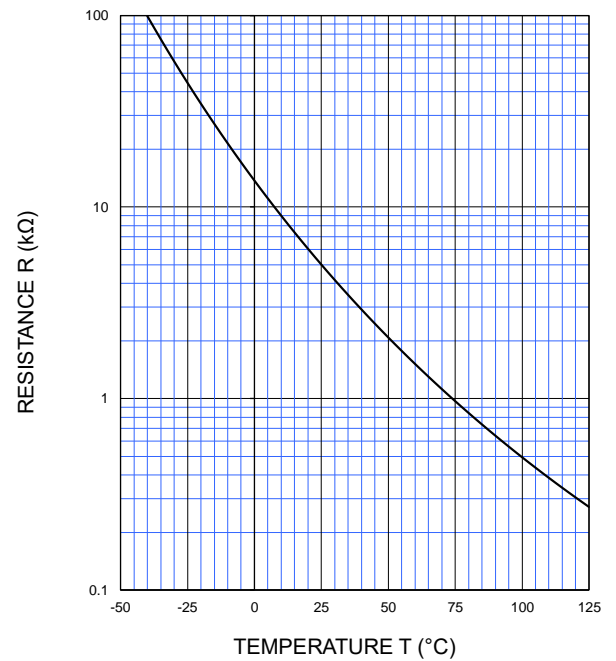

Note: The characteristics curves are presented for reference only and not guaranteed by production test, unless otherwise noted.

Important Notice

The information contained in this datasheet shall in no event be regarded as a guarantee of conditions or characteristics. This product has to be used within its specified maximum ratings, and is subject to customer's compliance with any applicable legal requirement, norms and standards.

Except as otherwise explicitly approved by Mitsubishi Electric Corporation in a written document signed by authorized representatives of Mitsubishi Electric Corporation, our products may not be used in any applications where a failure of the product or any consequences of the use thereof can reasonably be expected to result in personal injury.

In usage of power semiconductor, there is always the possibility that trouble may occur with them by the reliability lifetime such as Power Cycle, Thermal Cycle or others, or when used under special circumstances (e.g. condensation, high humidity, dusty, salty, highlands, environment with lots of organic matter / corrosive gas / explosive gas, or situations which terminals of semiconductor products receive strong mechanical stress). Therefore, please pay sufficient attention to such circumstances. Further, depending on the technical requirements, our semiconductor products may contain environmental regulation substances, etc. If there is necessity of detailed confirmation, please contact our nearest sales branch or distributor.

The contents or data contained in this datasheet are exclusively intended for technically trained staff. Customer's technical departments should take responsibility to evaluate the suitability of Mitsubishi Electric Corporation product for the intended application and the completeness of the product data with respect to such application. In the customer's research and development, please evaluate it not only with a single semiconductor product but also in the entire system, and judge whether it's applicable. As required, pay close attention to the safety design by installing appropriate fuse or circuit breaker between a power supply and semiconductor products to prevent secondary damage. Please also pay attention to the application note and the related technical information.

Keep safety first in your circuit designs!

Mitsubishi Electric Corporation puts the maximum effort into making semiconductor products better and more reliable, but there is always the possibility that trouble may occur with them. Trouble with semiconductors may lead to personal injury, fire or property damage. Remember to give due consideration to safety when making your circuit designs, with appropriate measures such as (i) placement of substitutive, auxiliary circuits, (ii) use of non-flammable material or (iii) prevention against any malfunction or mishap.

Notes regarding these materials

- These materials are intended as a reference to assist our customers in the selection of the Mitsubishi Electric Semiconductor product best suited to the customer's application; they do not convey any license under any intellectual property rights, or any other rights, belonging to Mitsubishi Electric Corporation or a third party.
- Mitsubishi Electric Corporation assumes no responsibility for any damage, or infringement of any third-party's rights, originating in the use of any product data, diagrams, charts, programs, algorithms, or circuit application examples contained in these materials.
- All information contained in these materials, including product data, diagrams, charts, programs and algorithms represents information on products at the time of publication of these materials, and are subject to change by Mitsubishi Electric Corporation without notice due to product improvements or other reasons. It is therefore recommended that customers contact Mitsubishi Electric Corporation or an authorized Mitsubishi Electric Semiconductor product distributor for the latest product information before purchasing a product listed herein.
The information described here may contain technical inaccuracies or typographical errors. Mitsubishi Electric Corporation assumes no responsibility for any damage, liability, or other loss rising from these inaccuracies or errors.
Please also pay attention to information published by Mitsubishi Electric Corporation by various means, including the Mitsubishi Electric Semiconductor home page (<http://www.MitsubishiElectric.com/semiconductors/>).
- When using any or all of the information contained in these materials, including product data, diagrams, charts, programs, and algorithms, please be sure to evaluate all information as a total system before making a final decision on the applicability of the information and products. Mitsubishi Electric Corporation assumes no responsibility for any damage, liability or other loss resulting from the information contained herein.
- Mitsubishi Electric Corporation semiconductors are not designed or manufactured for use in a device or system that is used under circumstances in which human life is potentially at stake. Please contact Mitsubishi Electric Corporation or an authorized Mitsubishi Electric Semiconductor product distributor when considering the use of a product contained herein for any specific purposes, such as apparatus or systems for transportation, vehicular, medical, aerospace, nuclear, or undersea repeater use.
- The prior written approval of Mitsubishi Electric Corporation is necessary to reprint or reproduce in whole or in part these materials.
- If these products or technologies are subject to the Japanese export control restrictions, they must be exported under a license from the Japanese government and cannot be imported into a country other than the approved destination.
Any diversion or re-export contrary to the export control laws and regulations of Japan and/or the country of destination is prohibited.
- Please contact Mitsubishi Electric Corporation or an authorized Mitsubishi Electric Semiconductor product distributor for further details on these materials or the products contained therein.

Generally the listed company name and the brand name are the trademarks or registered trademarks of the respective companies.