

# Z2 SMB 1 ... Z2 SMB 200 (2W)

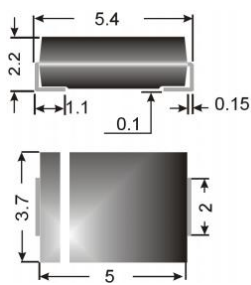

Surface mount diode

## Zener silicon diodes

### Z2 SMB 1 ... Z2 SMB 200 (2W)

**Maximum Power Dissipation: 2 W**

**Nominal Z-voltage: 1 to 200 V**

### Features

- Max. solder temperature: 260°C
- Plastic material has UL classification 94V-0
- Standard Zener voltage tolerance is graded to the international E 24 (5%) standard. Other voltage tolerances and higher Zener voltages on request.

### Mechanical Data

- Plastic case: SMB / DO-214AA
- Weight approx.: 0,1 g
- Terminals: plated terminals solderable per MIL-STD-750
- Mounting position: any
- Standard packaging: 3000 pieces per reel

1) Mounted on P.C. board with 50 mm<sup>2</sup> copper pads at each terminal  
 Tested with pulses  
 The Z2SMB1 is a diode operated in forward. Hence, the index of all parameters should be "F" instead of "Z".  
 The cathode, indicated by a white ring is to be connected to the negative pole.

Absolute Maximum Ratings		T <sub>s</sub> = 25 °C, unless otherwise specified	
Symbol	Conditions	Values	Units
P <sub>tot</sub>	Power dissipation, T <sub>A</sub> = 50 °C <sup>1)</sup>	2	W
P <sub>ZSM</sub>	Non repetitive peak power dissipation, t < 10 ms	40	V
R <sub>thA</sub>	Max. thermal resistance junction to ambient <sup>1)</sup>	60	K/W
R <sub>thT</sub>	Max. thermal resistance junction to case	15	K/W
T <sub>j</sub>	Operating junction temperature	- 50 ... + 150	°C
T <sub>s</sub>	Storage temperature	- 50 ... + 150	°C

Type	Zener Voltage V <sub>Z</sub> @I <sub>ZT</sub>		Test curr. I <sub>ZT</sub> mA	Dyn. Resistance Z <sub>ZT</sub> @ I <sub>ZT</sub>	Temp. Coeffiz. of V <sub>Z</sub> 10 <sup>-4</sup> °C	Reverse curr.		Z curr. T <sub>A</sub> = 50 °C i <sub>Zmax</sub> mA
	V <sub>Zmin</sub> V	V <sub>Zmax</sub> V				I <sub>R</sub> µA	V <sub>R</sub> V	
Z2SMB1 <sup>3)</sup>	0,71	0,82	100	0,5 (<1)	- 26 ... - 16		-	1200
Z2SMB6,2	5,8	6,6	100	1 (<2)	- 1 ... + 6	1	>1,5	303
Z2SMB6,8	6,4	7,2	100	1 (<2)	0 ... + 7	1	> 2	278
Z2SMB7,5	7	7,9	100	1 (<2)	0 ... + 7	1	> 2	253
Z2SMB8,2	7,7	8,7	100	1 (<2)	+ 3 ... + 8	1	> 3.5	230
Z2SMB9,1	8,5	9,6	50	2 (<4)	+ 3 ... + 8	1	> 3.5	208
Z2SMB10	9,4	10,6	50	2 (<4)	+ 5 ... + 9	1	> 5	189
Z2SMB11	10,4	11,6	50	4 (<7)	+ 5 ... + 10	1	> 5	172
Z2SMB12	11,4	12,7	50	4 (<7)	+ 5 ... + 10	1	> 7	157
Z2SMB13	12,4	14,1	50	5 (<10)	+ 5 ... + 10	1	> 7	142
Z2SMB15	13,8	15,6	50	5 (<10)	+ 5 ... + 10	1	> 10	128
Z2SMB16	15,3	17,1	25	6 (<15)	+ 6 ... + 11	1	> 10	117
Z2SMB18	16,8	19,1	25	6 (<15)	+ 6 ... + 11	1	> 10	105
Z2SMB20	18,8	21,2	25	6 (<15)	+ 6 ... + 11	1	> 10	94
Z2SMB22	20,8	23,3	25	6 (<15)	+ 6 ... + 11	1	> 12	86
Z2SMB24	22,8	25,6	25	7 (<15)	+ 6 ... + 11	1	> 12	78
Z2SMB27	25,1	28,9	25	7 (<15)	+ 6 ... + 11	1	> 14	69
Z2SMB30	28	32	25	8 (<15)	+ 6 ... + 11	1	> 14	63
Z2SMB33	31	35	25	8 (<15)	+ 6 ... + 11	1	> 17	57
Z2SMB36	34	38	10	16 (<40)	+ 6 ... + 11	1	> 17	53
Z2SMB39	37	41	10	20 (<40)	+ 6 ... + 11	1	> 20	49
Z2SMB43	40	46	10	24 (<45)	+ 7 ... + 12	1	> 20	43
Z2SMB47	44	50	10	24 (<45)	+ 7 ... + 12	1	> 24	40
Z2SMB51	48	54	10	25 (<60)	+ 7 ... + 12	1	> 24	37
Z2SMB56	52	60	10	25 (<60)	+ 7 ... + 12	1	> 28	33
Z2SMB62	58	66	10	25 (<80)	+ 8 ... + 13	1	> 28	30
Z2SMB68	64	72	10	25 (<80)	+ 8 ... + 13	1	> 34	28
Z2SMB75	70	79	10	30 (<100)	+ 8 ... + 13	1	> 34	25
Z2SMB82	77	88	10	30 (<100)	+ 8 ... + 13	1	> 41	23
Z2SMB91	85	96	5	40 (<200)	+ 9 ... + 13	1	> 41	21
Z2SMB100	94	106	5	60 (<200)	+ 9 ... + 13	1	> 50	19
Z2SMB110	104	116	5	80 (<250)	+ 9 ... + 13	1	> 50	17
Z2SMB120	114	127	5	80 (<250)	+ 9 ... + 13	1	> 60	16
Z2SMB130	124	141	5	90 (<300)	+ 9 ... + 13	1	> 60	14
Z2SMB150	138	156	5	100(<300)	+ 9 ... + 13	1	> 75	13
Z2SMB160	153	171	5	110(<350)	+ 9 ... + 13	1	> 75	12
Z2SMB180	168	191	5	120(<350)	+ 9 ... + 13	1	> 90	10
Z2SMB200	188	212	5	150(<350)	+ 9 ... + 13	1	> 90	9

# Z2 SMB 1 ... Z2 SMB 200 (2W)

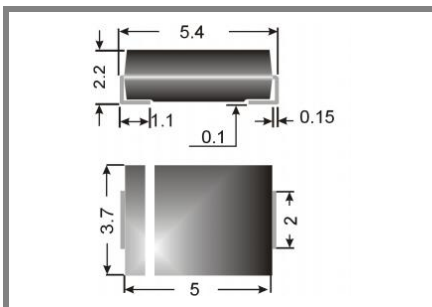

Surface mount diode

Type	Zener Voltage $V_Z @ I_{ZT}$	Test curr. $I_{ZT}$	Dyn. Resistance $Z_{ZT} @ I_{ZT}$	Temp. Coeffiz. of $V_Z$	Reverse curr.	Z curr. $T_A = 50$ $^{\circ}C$
	$V_{Zmin}$ V	$V_{Zmax}$ V		$10^{-4}$ $^{\circ}C$	$I_R$ $\mu A$   $V_R$ V	$i_{Zmax}$ mA

## Zener silicon diodes

### Z2 SMB 1 ... Z2 SMB 200 (2W)

**Maximum Power  
Dissipation: 2 W**

**Nominal Z-voltage: 1 to 200 V**

### Features

- Max. solder temperature: 260°C
- Plastic material has UL classification 94V-0
- Standard Zener voltage tolerance is graded to the international E 24 (5%) standard. Other voltage tolerances and higher Zener voltages on request.

### Mechanical Data

- Plastic case: SMB / DO-214AA
  - Weight approx.: 0,1 g
  - Terminals: plated terminals solderable per MIL-STD-750
  - Mounting position: any
  - Standard packaging: 3000 pieces per reel
- 1) Mounted on P.C. board with 50 mm<sup>2</sup> copper pads at each terminal  
 Tested with pulses  
 The Z2SMB1 is a diode operated in forward. Hence, the index of all parameters should be "F" instead of "Z".  
 The cathode, indicated by a white ring is to be connected to the negative pole.

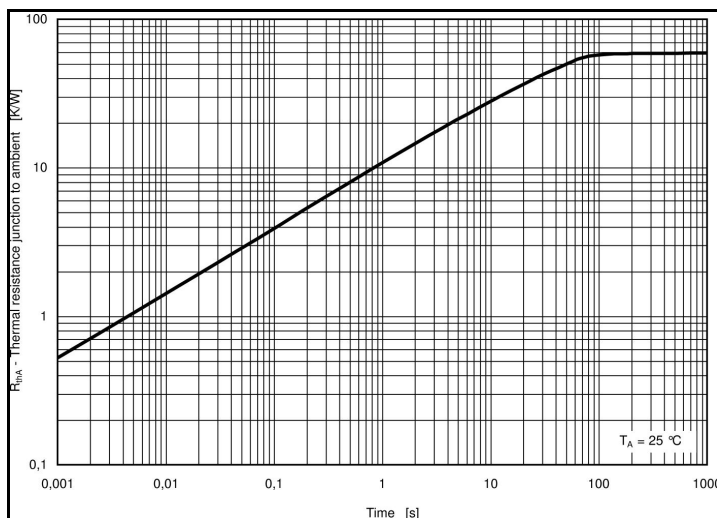

Fig. 1, Typical Transient Thermal Impedance