

P 1500 ATL ... P1500 STL

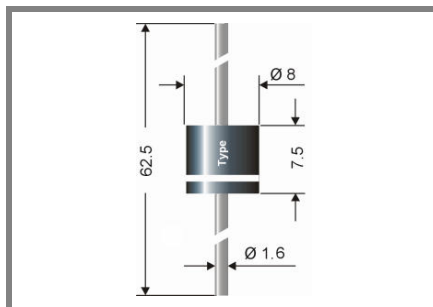

Axial lead diode

Standard silicon rectifier diodes

P 1500 ATL ... P1500 STL

Forward Current: 15 A

Reverse Voltage: 50 to 1200 V

Preliminary Data

Features

- Max. solder temperature: 260°C
- Plastic material has UL classification 94V-0

Mechanical Data

- Plastic case: 8 x 7,5 [mm]
- Weight approx.: 2 g
- Terminals: plated terminals solderable per MIL-STD-750
- Mounting position: any
- Standard packaging: 500 pieces per ammo or 1000 pieces per reel

- 1) Valid, if leads are kept at T_A at a distance of 10 mm from case
- 2) $I_F = 5 A$, $T_j = 25 ^\circ C$, $V_F@15A$ for types: P1500A-G < 910mV, P1500J-S < 970mV
- 3) $T_A = 25 ^\circ C$
- 4) Thermal resistance from junction to lead/terminal at a distance 0 mm from case
- 5) Max. junction temperature $T_j \leq 200 ^\circ C$ in bypass mode / DC forward mode

Type	Repetitive peak reverse voltage V_{RRM} V	Surge peak reverse voltage V_{RSM} V	Max. reverse recovery time $I_F = - A$ $I_R = - A$ $I_{RR} = - A$ t_{rr} ns	Max. forward voltage $V_F^{2)}$
P1500A TL	50	50	-	0,84
P1500B TL	100	100	-	0,84
P1500D TL	200	200	-	0,84
P1500G TL	400	400	-	0,84
P1500J TL	600	600	-	0,88
P1500K TL	800	800	-	0,88
P1500M TL	1000	1000	-	0,88
P1500S TL	1200	1200	-	0,88

Absolute Maximum Ratings

$T_A = 25 ^\circ C$, unless otherwise specified

Symbol	Conditions	Values	Units
I_{FAV}	Max. averaged fwd. current, R-load, $T_A = 50 ^\circ C$ ¹⁾	15	A
I_{FRM}	Repetitive peak forward current $f > 15 Hz$ ¹⁾	85	A
I_{FSM}	Peak forward surge current 50 Hz half sinus-wave ³⁾	600	A
i^2t	Rating for fusing, $t < 10 ms$ ³⁾	1800	A ² s
R_{thA}	Max. thermal resistance junction to ambient ¹⁾		K/W
R_{thL}	Max. thermal resistance junction to terminals ⁴⁾	1,8	K/W
T_j	Operating junction temperature	- 50 ... + 175 ($T_j \leq 200 ^\circ C$ in bypass mode ⁵⁾)	$^\circ C$
T_s	Storage temperature	- 50 ... + 175	$^\circ C$

Characteristics

$T_A = 25 ^\circ C$, unless otherwise specified

Symbol	Conditions	Values	Units
I_R	Maximum leakage current, $T_j = 25 ^\circ C$; $V_R = V_{RRM}$	<25	μA
	$T_j = ^\circ C$; $V_R = V_{RRM}$		
C_j	Typical junction capacitance (at MHz and applied reverse voltage of V)	-	pF
Q_{rr}	Reverse recovery charge ($U_R = V$; $I_F = A$; $dI_F/dt = A/ms$)	-	μC
E_{RSM}	Non repetitive peak reverse avalanche energy ($I_R = mA$; $T_j = ^\circ C$; inductive load switched off)	-	mJ

