

TC350 Series-Office Building Application Stand-alone Programmable Fan Coil Thermostat



The TC350 series stand-alone programmable fan coil thermostat is designed for temperature control in industrial, commercial and residential environments. The thermostat improves comfort and saves energy by comparing the room temperature with the desired setting. This information is used to control the fan coil unit.

TC350 features microprocessor-based control and a large LCD screen. The LCD display modes include operation status (cooling, heating, ventilation), fan speed, room temperature, and temperature setting. The following buttons are provided: power switch/fan speed adjustment button "⌘", mode switching button (M), energy saving button (Eco) and temperature setting button "▲▼".

Features

- Modern appearance
- Large, blue backlit, LCD screen
- Eco button for energy saving
- Weekly programmable control application
- Energy savings mode-external energy savings input from occupancy sensor overrides comfort setpoint with setback heating or cooling setpoint
- Energy saving input configurable, normally open or normally closed
- Real time display
- Optional remote sensor
- Button lockout function avoids unauthorized operation
- Non-volatile memory (EEPROM) retains user setting during power loss
- Low temperature protection
- Standard 86x86mm box for installation
- Temperature sensors are provided with failure alarm function to facilitate maintenance

Technical specifications

- Sensing element: NTC
- Control accuracy: $\pm 1^{\circ}\text{C}$
- Setpoint range: $5 \sim 35^{\circ}\text{C}$
- Display range: $0 \sim 50^{\circ}\text{C}$
- Operating environment: $0 \sim 45^{\circ}\text{C}$
- Environment humidity: $5 \sim 95\% \text{ RH}$ (non-condensing)
- Button: Touch button
- Power requirement: $< 1 \text{ W}$
- Power supply: AC $85 \sim 260 \text{ V}$, 50/60Hz
- Terminals: can be connected to $2 \times 1.5 \text{ mm}^2$ or $1 \times 2.5 \text{ mm}^2$ conductors
- Load current: 2 A (resistive load), 1 A (inductive load)
- Enclosure: Flame-retardant PC engineering plastic
- Dimensions: 88.5 x 86 x 16 mm (W x H x D)
- Hole pitch: 60 mm (standard)
- Protection class: IP30

Model description

TC353 -3□

A2DLS: Designed for two-pipe systems and used to control two-wire motorized valves and three-speed fans. Once the temperature setting is reached, the motorized valve will be shut off and the fan will continue to run (factory default) or shut down (with configurable parameter).

A4DLS: Designed for four-pipe systems and used to control two-wire cold/hot motorized valves and three-speed fans. Once the temperature setting is reached, the motorized valve will be shut off and the fan will continue to run (factory default) or shut down (with configurable parameter).

It can also be adapted to two-pipe systems through parameter adjustment in order to control three-wire motorized valves. In this case, once the temperature setting is reached, the motorized valve will be shut off and the fan will continue to run (with configurable parameter) or shut down (with configurable parameter).

Accessory

IR-300: Remote controller

RS-03: Remote sensor

Operation instructions

- Power on/off: Press and hold "⏻" button for two seconds to turn the power on. Press and hold "⏻" button again for two seconds will turn off the power as well as the fan coil and motorized valve.

- Temperature setting: With the power on, press "▼" to decrease the temperature setting and "▲" to increase in steps of 0.5°C.

- Mode selection: With the power on, press M button to switch the operation mode. The LCD indicates cooling with "❄️", heating with "☀️", and ventilation with "🌀".

- Air speed selection: With the power on, press "⏻" button to select fan speed: "🌀" (high), "🌀" (medium), "🌀" (low) or "🌀" (automatic) shift.

- In automatic mode, the air speed shift changes automatically: With a 1°C, 2°C and 3°C difference between room temperature and the temper-

ature setting, the low, medium and high air speed shift will be automatically selected respectively.

- Motorized valve control (A2DLS model): In cooling (heating) mode, the motorized valve will be switched on when the room temperature is higher than (lower than) the temperature setting by 1°C and switched off when the room temperature reaches the temperature setting.

- Motorized valve control (A4DLS model): In cooling mode, the cold water valve will be opened when the room temperature is 1°C higher than the temperature setting or closed when the room temperature drops to the setting, and the hot water valve will remain closed. In heating mode, the hot water valve will be opened when the room temperature is 1°C lower than the temperature setting or closed when the room temperature rises to the setting, and the cold water valve will remain closed.

Energy saving mode

Press Eco button to start the energy saving mode. If the thermostat runs in cooling mode the temperature will be set to 26°C automatically and the fan will operate at low speed. If the thermostat runs in heating mode the temperature will be set to 18°C automatically and the fan will operate at low speed. To exit the energy saving mode,, press Eco again or press "▲" or "▼".

Energy-saving mode of occupancy sensor: It can be switched into energy-saving mode and occupancy sensor. For example, after room key is taken out, if thermostat is in cooling mode, the temperature will be automatically set at 28°C and fan is on low speed; if thermostat is on heating mode, 16°C will be set automatically with fan operating at low speed; the mode that guest has previously chosen will be switched back after the room key is plug in.

Program setting function

Program setting function: During power on, press and hold "M" and "▼" buttons for 3 seconds to enter programmable setting display screen. Press M button again to enter 7 days 4 phases

and temperature setpoint parameters. Press "▲" and "▼" to adjust this parameter.

Timing setting function

During power on, press and hold M button for 3 seconds to enter the display screen. Press "M" button again to select hour, minute, week, working day timing on, working day timing off parameters. Press "▲" and "▼" to adjust this parameter.

Factory default parameter:working day(Monday to Friday) timing on is 8:00, timing off is 18:00.

Button lockout function

Pressing and holding "▲" and "▼" at the same time for five seconds will activate keypad lockup function to prevent thermostat operation by others. Once this function is activated, press and hold "▲" and "▼" at the same time for five seconds to unlock the buttons.

Dimension

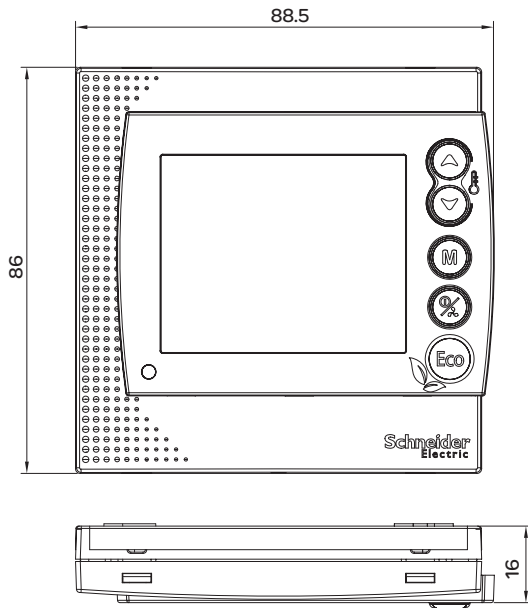

Low temperature protection function

If the thermostat is powered off and the room temperature drops below 5°C, the thermostat will start automatically for heating and display the "▲" symbol. The fan will run at high speed au-

tomatically and the motorized valve will be opened (hot water valve will be opened for A4DLS model). When the room temperature rises to 7°C, the thermostat will automatically switch off the output.

Alarm

If a failure occurs in the sensor, the thermostat will shut off the fan and the motorized valve and display "✕" and E1 or E2.

E1: Sensor short-circuit alarm. E2: Sensor open-circuit alarm.

HI will be displayed if the temperature is higher than 50°C. LO will be displayed if the temperature is lower than 0°C.

Parameter setting

During power off, press and hold M button for 5 seconds to enter the display screen. Press M button again to select parameters as shown in the table below. Press "▲" and "▼" to adjust this parameter.

No.	Parameter	Factory default	Function description
01	Low temperature protection	OF	OF: Low temperature protection deactivated; On: Low temperature protection activated
02	Fan operation status after temperature setting is reached	01	00: Fan off 01: Fan on
03	Selection between two-pipe and four-pipe system	TC353-3A2DLS:00 TC353-3A4DLS:01	00: Two-pipe system; 01: Four-pipe system
06	12/24 hour timing setting	24	24: 24 hour 12: 12 hour
07	Mode selection	00	00: FCU cooling or heating 01: FCU cooling only 02: FCU heating only 03: Thermal valve heating
08	Working day timing +Programmable	03	00: Working day timing+Programmable deactivated 01:Programmable activated 02: Working day timing activated 03: Working day timing+Programmable

Note: For TC353-3A2DLS thermostat, the 03 parameter default is for 2 pipe system only.
For TC353-3A4DLS thermostat, the 03 parameter default can be changed from four-pipe system with two-wire motorized valve to two-pipe system with three-wire motorized valve.
The 07 parameter change is only for two pipe system TC353-3A2DLS thermostat.

Warning: This parameter table must be set by specialized installation personnel authorized by Schneider Electric. Any inconvenience or damage caused by unauthorized operation will not be covered by warranty.

Wiring Diagram

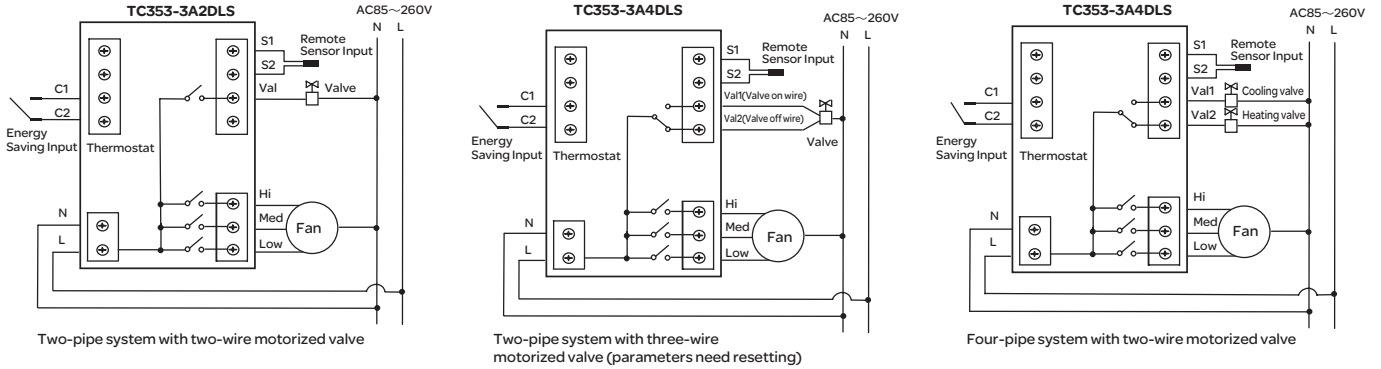

Installation diagram

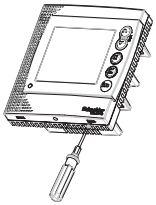

1. Remove the main control board and insert a 3.5 mm wide flatheaded screwdriver along the bevel into the slot for 4 mm. Pry it upward with a slight force to release the hook.

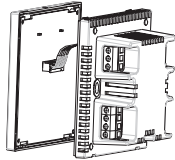

2. Completely remove the wires from the unit.

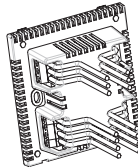

3. Connect the wires in accordance with the connection diagram shown above.

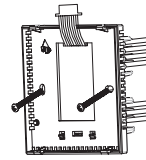

4. Use the two screws supplied in the package box to secure the wired thermostat base plate to the wall.

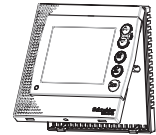

5. Put the two upper hooks in place at 30 degrees. Press the two lower corners of the thermostat with a slight force to lock the upper cover. The installation is now finished.

Warning: Please connect the wires in strict accordance with the connection diagram. Avoid the ingress of foreign matter such as water or slurry into the thermostat, otherwise it can be damaged!