

Magelis® Human/Machine Interfaces

Catalog
2010





A full range of catalogs for



Detection



Global Detection Electronic and electromechanical sensors

MKTED208052EN

Photo-electric sensors
Proximity sensors
Capacitive proximity sensors
Ultrasonic sensors
Limit switches
Pressure switches
Rotary encoders
Radio frequency identification
Machine cabling accessories

Automation



Modicon® Quantum™ automation platform Catalog 2009

MKTED208011EN-US

Safety PLCs
Safety CPUs
Unity™ Concept™ and
ProWORX™ software



Modicon® Premium™ automation platform Catalog 2010

MKTED208054EN-US

Unity processors
PL7 processors
Communication software



Modicon® M340™ automation platform Catalog 2010

DIA6ED2081007EN-US

PLCs
Discrete, analog I/O and
application-specific solutions
Communication

Automation



Modicon® Momentum™ distributed I/O and control

MKTED205061EN



Twido® programmable controller and TwidoSuite™ software

DIA3ED2090202EN

Controller base
Discrete, analog I/O
Communication



Automation functions, relays, interfaces and power supplies

MKTED207031EN

Smart relays
Timing relays
Measurement & control relays
Analog interfaces
Counters
Plug-in relays
Interfaces for discrete signals
Power supplies & transformers

Software

PLCs and safety controllers
programming software

Operator dialog



Control and signalling components

MKTED208031EN

Control and signalling units
Control stations & enclosures
Cam switches
Beacons and indicator banks
Pendant control stations
Controllers
Emergency stops
Foot switches



Magelis® Human/Machine Interfaces Catalog 2010

MKTED206071EN-US

Operator interface terminals
Industrial PCs
HMI and SCADA PC-based
software

Software

Vijeo Designer
Operator terminal software

Motion and Drives



Lexium® 32 Servo Drives motion control Catalog 2009/2010

DIA7ED2090405EN-US

Motion controllers
Servo drives and Servo motors
Stepper motors and drives
Integrated drives
Modicon Premium
motion control modules



Soft starters and variable speed drives

MKTED206111EN







Soft starters and variable speed
drives

Software

Software for drives
Motor control programming
software

.....Automation & Control functions



Motor control	Machine safety	Interfaces and I/O	Power supplies	Systems & architectures
<p> Motor starter solutions Control and protection components</p> <p>MKTED205103EN</p> <p>Contactors Circuit-breakers, fuse carriers Thermal relays Combinations, motor controllers Mounting solutions Motor starter mounting kits</p>	<p><i>This catalog contains Automation and Control function products relating to machines Safety</i></p> <p> Preventa™ Machine Safety Products Catalog 2009</p> <p>MKTED208051EN-US</p> <p>Safety PLCs Safety controllers Safety monitors Safety solutions on AS-Interface cabling system Safety switches Safety light curtains Safety mats Emergency stops Control stations Enabling switches Foot switches Beacons & indicator banks Switch disconnectors Thermal-magnetic motor circuit breakers Enclosed D.O.L. starters</p> <p>Software XPSMFWIN configuration software XPSMCWIN configuration software</p>	<p> Terminal blocks</p> <p>MKTED207011EN</p> <p>Terminal blocks Cable ends</p> <p> Advantys™ STB IP 20 distributed inputs/outputs Catalog 2010</p> <p>MKTED208053EN-US</p> <p>Modules for automation station Network interfaces Power distribution Digital I/O, analogs and application-specific</p> <p>Software STB configuration software</p>	<p> Phaseo® power supplies and transformers</p> <p>DIA3ED2061209EN</p> <p>Switch mode power supplies Filtered rectified power supplies Transformers</p>	<p><i>This catalog contains Automation and Control function products relating to Communication</i></p> <p> Machine & Installations with industrial communication</p> <p>MKTED207012EN</p> <p>Preferred implementations Ethernet TCP/IP, the universal communication standard CANopen for machines and installations AS-interface, simple and safe</p> <p>Products Human-Machine interface Controllers and PLCs Field devices Infrastructure and wiring Gateways</p> <p>Software and tools Collaborative Automation Partner Program & Partners</p>

1 – Operator dialog terminals

Magelis® Small Panels

Selection guide	1/2
Magelis STO/STU Small Panels	1/12
Magelis XBT N Small Panels	1/13
Magelis XBT R Small Panels	1/15
Magelis XBT RT Small Panels	1/19

Magelis® Advanced Panels

Selection guide	1/24
Magelis XBT GT Advanced Panels 3.8", 5.7", 7.5", 10.4", 12.1", 15"	1/50
Magelis XBT GK Advanced Panels 5.7", 10.4"	1/51
Magelis XBT GH Advanced Panels 5.7"	1/51
Magelis XBT GTW Advanced Panels 8.4", 12", 15"	1/52

2 – Industrial PCs

Magelis® Smart Embedded Panels and Magelis® Compact iPC PC Panels

Selection guide	2/2
Magelis Smart Embedded Panels 8.4", 12", 15"	2/4
Magelis Compact iPC PC Panels 8.4", 12", 15"	2/12

Magelis® Smart BOX, Magelis® Compact PC BOX, Magelis® Flex PC BOX and Front Panels

Selection guide	2/24
Magelis Smart BOX	2/39
Magelis Compact PC BOX	2/40
Magelis Flex PC BOX	2/41
Front Panels for Magelis Flex PC BOX	2/43
Separate parts for Magelis Flex PC BOX	2/44

Magelis® iDisplay flat screens

Selection guide	2/52
Magelis iDisplay flat screens	2/54

Magelis® HMI Controller

Magelis XBT GC Compact HMI Controller	2/55
---	------

3 – Magelis® HMI software

Selection guide	3/2
------------------------------	------------

Configuration software

Vijeo Designer™ Lite configuration software	3/7
Vijeo Designer configuration software	3/17

4 – Services

Technical appendices

Certifications for automation products	4/2
--	-----

Index

Product reference index	4/5
-------------------------------	-----

1.1 - Magelis® Small Panels

Selection guide 1/2

- Architectures, connection to automation systems 1/4
- Magelis STO/STU Small Panels 1/12
- Magelis XBT N Small Panels 1/13
- Magelis XBT R Small Panels
 - with 4-line matrix screen 1/15
- Equivalent product tables for Magelis XBT P to XBT R 1/17
- Magelis XBT RT Small Panels
 - with 10-line matrix screen 1/19
- Separate parts for Magelis XBT N/R/RT Small Panels 1/21

1.2 - Magelis® Advanced Panels

Selection guide 1/24

- Magelis XBT GT Advanced Panels
 - 3.8", 5.7", 7.5", 10.4", 12.1", 15" screen 1/50
- Magelis XBT GK Advanced Panels
 - 5.7", 10.4" screen 1/51
- Magelis XBT GH Advanced Panels
 - 5.7" screen 1/51
- Magelis XBT GTW Advanced Panels
 - 8.4", 12", 15" screen 1/52
- Separate parts for Magelis XBT GT/GK/GH/GTW 1/53
- Wiring system 1/60
- Equivalent product tables for Magelis XBT F, XBT FC to XBT GT and XBT F to XBT GK 1/64
- Equivalent product tables for Magelis XBT G to XBT GT 1/65
- Dimensions, mounting
 - Magelis XBT N/R/RT Small Panels 1/68
 - Magelis XBT GT Advanced Panels 1/68
 - Magelis XBT GK/GH/GTW Advanced Panels 1/69

Operator dialog terminals

Magelis® XBT N, XBT R and XBT RT Small Panels

1

Applications

Display of text messages

Type of terminal

Small Panels with keypad



Display	Type
	Capacity

Green back-lit LCD, height 5.5 mm or Green, orange or red back-lit LCD, height 4.34 to 17.36 mm
2 lines of 20 characters or 1 to 4 lines of 5 to 20 characters

Data entry

Via keypad with 8 keys (4 customizable)

Memory capacity	Application
	Expansion by PCMCIA type II

512 KB Flash
–

Functions	Maximum number of pages
	Variables per page
	Representation of variables
	Recipes
	Curves
	Alarm logs
	Real-time clock
	Alarm relay
	Buzzer

128/200 application pages 256 alarm pages
40 to 50
Alphanumeric
–
–
Depending on model
Access to the PLC real-time clock
–
–

Communication	Asynchronous serial link
	Downloadable protocols
	Printer link

RS 232C/RS 485
Uni-TE™, Modbus®, and for PLC brands: Allen-Bradley, Omron, Mitsubishi, Siemens
RS 232C serial link (2)

Development software
Operating system

Vijeo Designer™ Lite (page 3/7) (on Windows® 2000, Windows XP® and Windows Vista®)
Magelis®

Terminal type

XBT N

Pages

1/13

(1) Only XBT RT511.
(2) Depending on model.

Display of text messages Control and parametering of data	Display of text messages and/or semi-graphics Control and parametering of data
--	---

Small Panels with keypad	Small Panels with touch screen and keypad
---------------------------------	--



Green, orange or red back-lit LCD, height 4.34 to 17.36 mm	Green, orange or red back-lit LCD (198 x 80 pixels), height 4 to 16 mm
1 to 4 lines of 5 to 20 characters	2 to 10 lines of 5 to 33 characters

Via keypad with 12 function keys or numeric entry (depending on context) + 8 service keys	Via keypad with 4 function keys 8 service keys	Via touch screen and keypad with 10 function keys 2 service keys
---	--	--

512 KB Flash	512 KB Flash EPROM
-	-

128/200 application pages 256 alarm pages	200 application pages 256 alarm pages
40 to 50	50
Alphanumeric	Alphanumeric, bargraph, buttons, lights
-	-
-	Yes
Yes	Yes
Access to the PLC real-time clock	
-	
-	Yes (1)

RS 232C/RS 485
Uni-TE™, Modbus®, and for PLC brands: Allen-Bradley, Omron, Mitsubishi, Siemens
RS 232C serial link (2)

Vijeo Designer™ Lite (page 3/7) (on Windows XP® and Windows Vista®)
Magelis®

XBT R	XBT RT
--------------	---------------

1/15	1/19
------	------

Architectures, connection to automation systems

Magelis® operator dialog terminals communicate with automation system equipment:

- Via serial link.
- Via fieldbus.
- In network architectures.
- By integration into an architecture with Ethernet TCP/IP network.

Point-to-point or multidrop connection with PLC via serial link

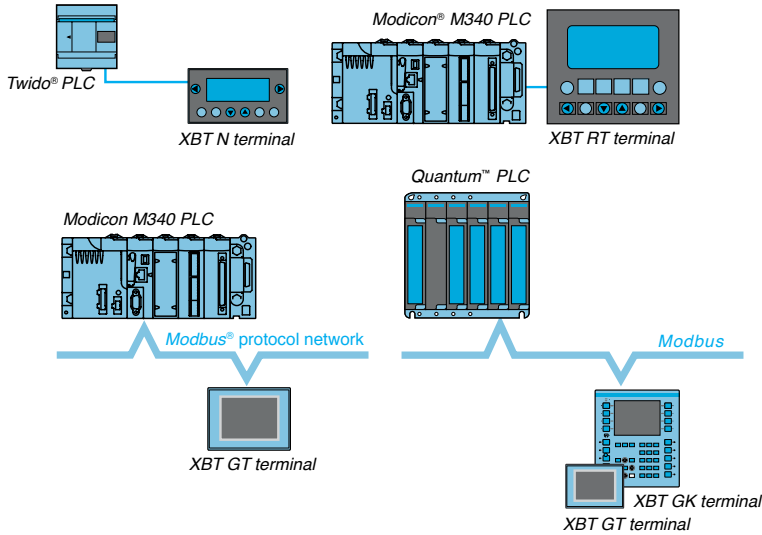

All terminals incorporate an RS 232C, RS 422/485 asynchronous serial link as standard.

The use of Uni-TE™ and Modbus® protocols means that communication can be set up easily with Schneider Electric Modicon PLCs. Modicon.

Third party protocols provide connection to PLCs offered by the main suppliers on the market:

- DF1, DH485 for Allen-Bradley PLCs.
- Sysmac® Way for Omron PLCs.
- MPI/PPI for Siemens Simatic S7 PLCs.
- Mitsubishi Melsec® FX PLC.

Operator dialog terminals

Architectures, connection to automation systems

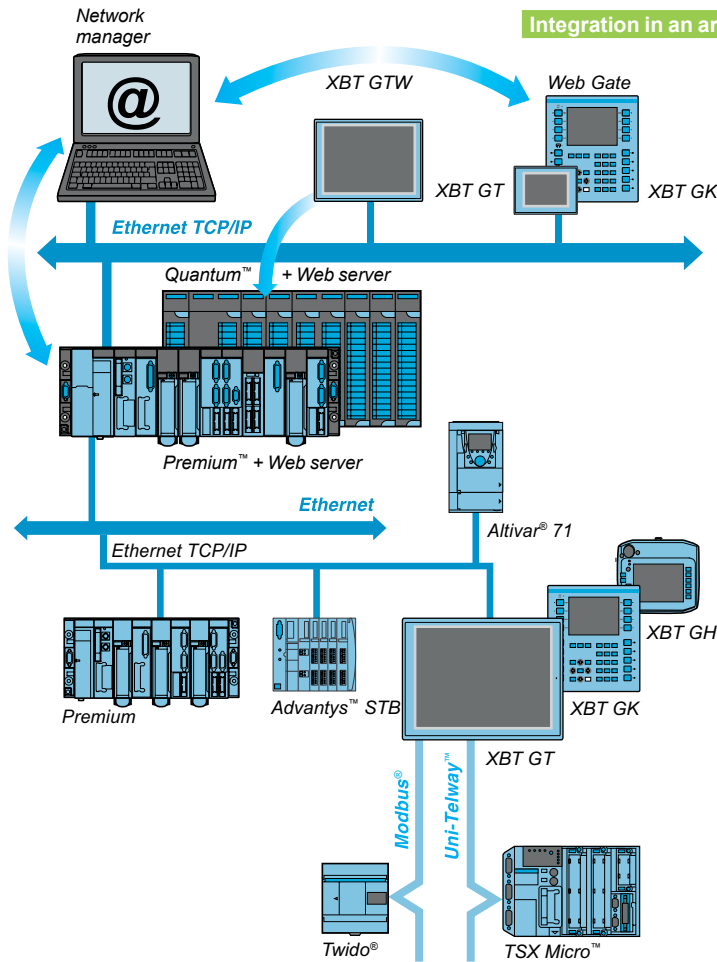

Integration in an architecture with Ethernet TCP/IP network

Automation platforms provide transparent routing of Uni-TE™ or Modbus® messages from a TCP/IP network to a Uni-TE or Modbus network and vice versa.

- The various services offered for the terminals are:
- Modbus TCP/IP messaging (for XBT GT, XBT GK, XBT GH and XBT GTW, access with Ethernet TCP/IP Modbus protocol).
 - Browse function with XBT GTW or standard PC.
 - Web Gate function:
 - Diagnostics for remote control of the application.
 - FTP server: Transfer of data files with the terminal.
 - Data Sharing function: Data exchanges on Ethernet between 8 terminals (maximum).

Operator dialog terminals

Magelis® XBT N, XBT R and XBT RT
Small Panels

1

Introduction



XBT R411

XBT N400

XBT RT511

Magelis® XBT N and Magelis® XBT R/RT terminals are used to display messages and variables. In addition, Magelis XBT RT terminals can display small graphic elements.

The various keys can be used to:

- Modify variables
- Control a device
- Navigate within the operator dialog application

On XBT RT terminals, the touch screen can also be used to modify variables, control devices and navigate within the dialog application.

Alarm messages can be printed out from models that have a printer port.

Operation



"Entry" customization



"Control" customization

All Magelis terminals have the same user interface:

- A configurable touch screen, on XBT RT only ("touch-sensitive" mode)
- 2 service keys (◀, ▶) configurable for contextual link or control, on XBT N/R and XBT RT ("entry"/"control" modes)
- 2 non-configurable service keys (ESC, ENTER)
- In addition to these keys:
 - On XBT N terminals: 4 customizable service keys which can be configured as function keys ("control" mode) or service keys ("entry" mode)
 - On XBT R terminals: 4 non-configurable service keys and 12 function or numeric entry keys (depending on context)
 - On XBT RT terminals in "control" or "entry" mode: 4 customizable, configurable function keys. 4 non-configurable service keys.

Configuration

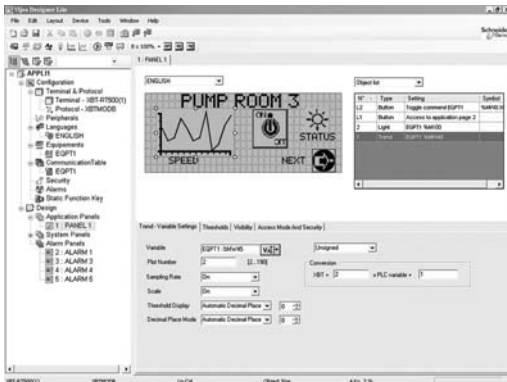

Vijeo Designer™ Lite

Magelis® terminals can be configured using Vijeo Designer™ Lite software, in a Windows environment.

The Vijeo Designer Lite software uses the concept of pages: each page can be viewed in its entirety. A 2, 4, or 10-line window, depending on the terminal model to be configured, is used to view the screen of this virtual terminal.

The symbol databases of TwidoSoft™, PL7™ and Concept™ applications can be imported into the Vijeo Designer Lite operator dialog application.

Communication

XBT N terminal

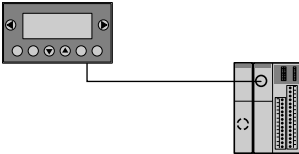

Twido® controller

XBT N and XBT R/RT terminals communicate with PLCs via an integrated serial link in either point-to-point or multidrop mode, depending on the model.

The communication protocols used are those of Schneider Electric PLCs (Uni-TE™, Modbus®) and those of the main manufacturers on the market.

Operator dialog terminals

Magelis® XBT N, XBT R and XBT RT Small Panels

Functions

XBT N/R/RT terminals have function and service keys on the front panel (according to “control” or “entry” configuration).

XBT RT terminals have a touch screen which can be configured in “touch-sensitive” operating mode.

“F” function keys

The function keys are defined for the whole application.

The number of function keys depends on the model:

- F1, F2, F3, F4 on XBT N
- F1 to F12 on XBT R
- F1 to F10 or F1...F4 according to configuration on XBT RT

They can provide the following functions:

- Access to a page
- Pulsed control
- Toggle command

In addition, with the XBT R terminal, if the **MOD** key is pressed, the 12 function keys become numeric entry keys **1 to 0**, **+/-** and **..**

“R” function keys for XBT RT (“entry” mode)

The R1, R2, R3 and R4 function keys on the XBT RT are defined for the pages displayed. They can be used to:

- Access a page
- Latch memory bits
- Toggle memory bits (ON/OFF)
- Set memory bits to one/zero

An icon can be displayed on the screen, above the **Ri** keys. This icon is defined using the Vijeo Designer™ Lite software.

Matrix touch screen (5 x 11 cells) for XBT RT

The touch screen can be configured to be active on XBT RT (“touch-sensitive” mode).

This is used to:

- Access a page
- Latch/toggle memory bits
- Modify a numeric field via a virtual numeric keypad

Service keys

■ Service keys **◀, ESC, DEL, ▼, ▲, MOD, ENTER, ▶**, are used to modify the parameters of the automation system.

They perform the following actions:

ESC Cancel an entry, suspend or stop a current action, go up one level in a menu

DEL Delete the character selected in entry mode

MOD Select the variable field to enter. Authorize the entry of the next field, on each press, from left to right and top to bottom.

ENTER Confirm a selection or an entry, acknowledge an alarm

■ The “arrow” keys are used to:

- ◀ ▶ Change page in a menu
- ◀ ▶ Display current alarms
- ◀ ▶ Change digit in a variable field during input
- ◀ ▶ Activate the function associated with a functional link
- ▼ ▲ Move up and down within a page (XBT N40●)
- ▼ ▲ Select the value of a digit
- ▼ ▲ Select a value in a selection list
- ▼ ▲ Increment or decrement the value of a variable field

Description of XBT N terminals

XBT N terminals include:

On the front panel

- 1 A communication monitoring lamp (model XBT N401)
- 2 A backlit ultra bright LCD display: 122 x 32 pixels (matrix) or 2 lines of 20 characters (alphanumeric)
- 3 2 non-customizable control or contextual link keys
- 4 An "alarm" lamp (model XBT N401)
- 5 Six service keys, 4 of which (shown in frame) can be configured as function keys and customized with labels
- 6 2 system lamps in entry mode or 4 lamps that can be controlled by PLC in control mode (model XBT N401)

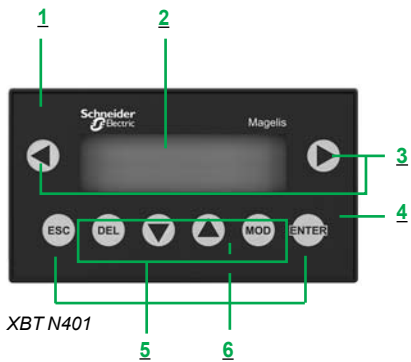
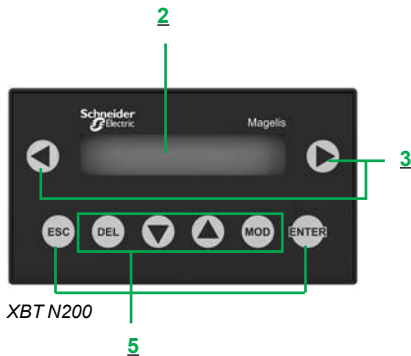

Supplied separately

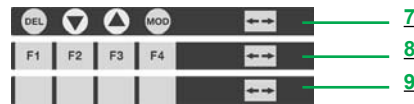

- A sheet of labels including:
 - 7 An "entry" label
 - 8 A "control" label, F1, F2, F3 and F4
 - 9 4 blank customizable labels
- 2 spring clips for mounting the terminal on a panel

On the rear panel

XBT N200/N400 terminals

- 1 An RJ 45 connector for point-to-point serial link and connection of the 5 V $\overline{\text{DC}}$ power supply (provided by the PLC)

XBT N401/N410/NU400 terminals

- 2 A removable screw terminal block for the 24 V $\overline{\text{DC}}$ external power supply
- 3 A 25-way female SUB-D connector for multidrop serial link
- 4 An 8-way female mini-DIN connector for serial printer link (model XBT N401)

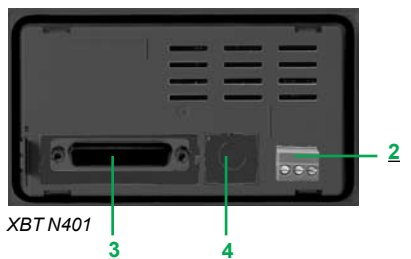
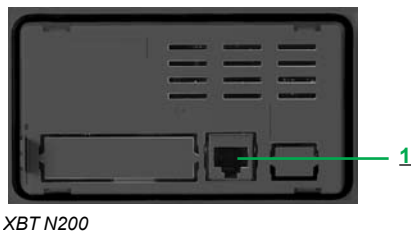

Operator dialog terminals

Magelis® XBT N, XBT R and XBT RT Small Panels

Description of XBT R terminals with keypad

1

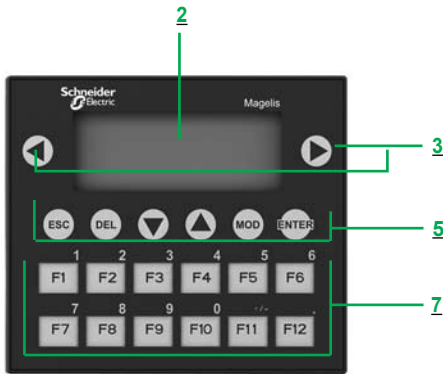

XBT R400

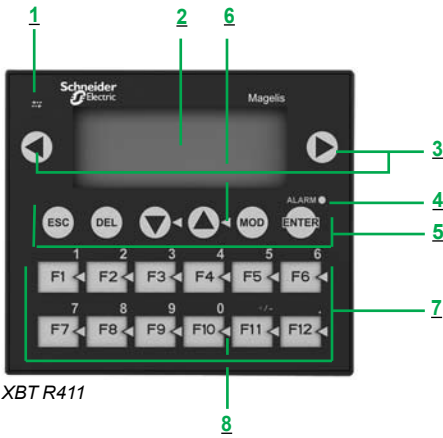

XBT R411

XBT R terminals include:

On the front panel:

- 1 A communication monitoring lamp (model XBT R411)
- 2 A backlit ultra bright LCD display: 122 x 32 pixels (matrix)
- 3 Two non-customizable control or contextual link keys
- 4 An "alarm" lamp (model XBT R411)
- 5 Six service keys
- 6 2 system lamps (model XBT R411)
- 7 12 function or numeric entry keys (depending on context) that can be customized with labels
- 8 12 lamps (for model XBT R411), that can be controlled by the PLC

Supplied separately:

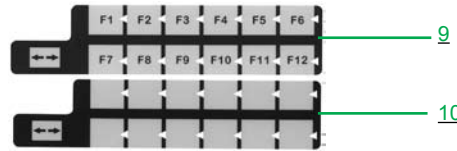

- A sheet of labels comprising:
 - 9 A "control" label, F1, F2, ...F12
 - 10 2 blank customizable labels
- 4 spring clips for mounting the terminal on a panel

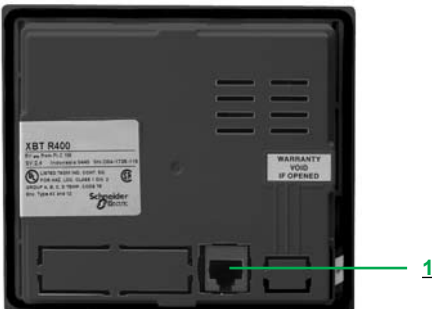

XBT R400

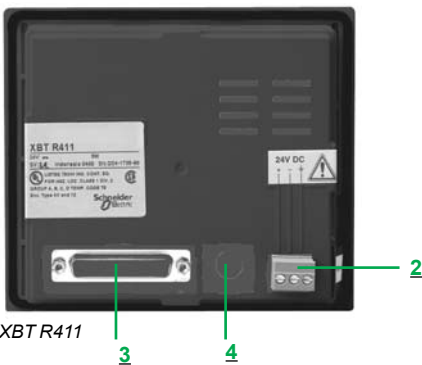

XBT R411

On the rear panel

XBT R400 terminals

- 1 An RJ 45 connector for point-to-point serial link and connection of the 5 V power supply (provided by the PLC)

XBT R410/R411 terminals

- 2 A removable screw terminal block for the 24 V external power supply
- 3 A 25-way female SUB-D connector for multidrop serial link
- 4 An 8-way female mini-DIN connector for serial printer link (model XBT R411)

Description of XBT RT terminals with touch screen and keypad

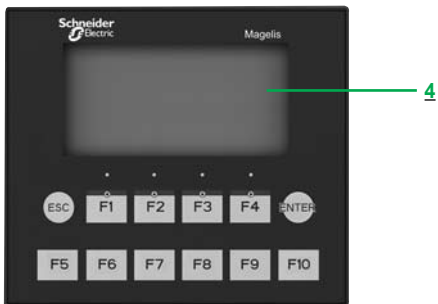
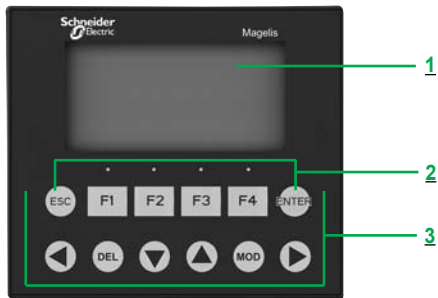

XBT RT 500

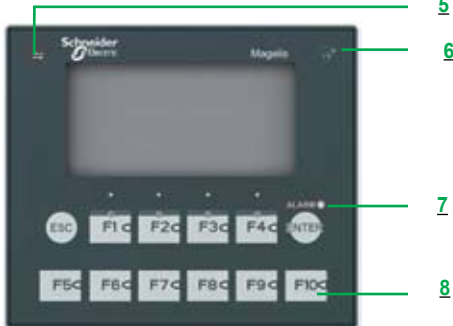

XBT RT511



XBT RT500

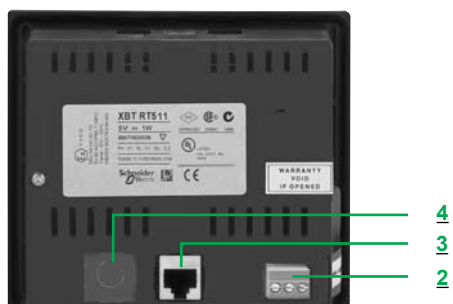

XBT RT511

XBT RT terminals include:

On the front panel:

XBT RT terminals

- 1 A backlit ultra bright LCD display: 198 x 80 pixels (matrix)
- 2 2 service keys
- 3 Configurable function or service keys that can be customized using labels
- 4 Matrix touch screen, 11 x 5 cells

XBT RT511 terminal

- 5 A communication monitoring lamp
- 6 A "touch panel or keys being pressed" lamp
- 7 An "alarm" lamp
- 8 6 or 10 lamps, depending on the configuration, that can be controlled by the PLC

Supplied separately:

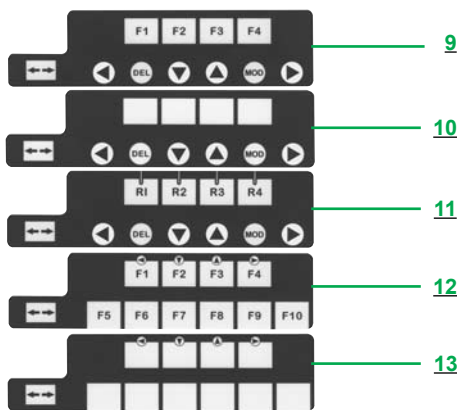

- 2 sheets of labels comprising:
 - 9 A configurable "control" label, F1 to F4
 - 10 A blank customizable "control" label
 - 11 An "entry" label, R1 to R4
 - 12 A "touch sensitive" label, F1 to F10
 - 13 2 blank customizable "touch-sensitive" labels

On the rear panel

XBT RT500 terminal

- 1 An RJ 45 connector for point-to-point serial link and connection of the 5 V $\overline{\text{DC}}$ power supply (provided by the PLC).

XBT RT511 terminal

- 2 A removable screw terminal block for the 24 V $\overline{\text{DC}}$ external power supply
- 3 An RJ45 connector for multidrop serial link
- 4 An 8-way female mini-DIN connector for serial printer link

1

With graphic screen



Type	Specifications			
Display	LCD screen size / Resolution	3.4" / monochrome (200 X 80 pixels)		3.5" / QVGA (320 X 240 pixels)
	Type	Green, orange, red	White, pink, red	TFT 65 536 colors
Functions	Representation of variables	Alphanumeric, bitmap, bargraph, gauge, button, light, clock, flashing light, keypad		
	Curves / Alarm logs	Yes, with log / Yes, incorporated		
Communication	Serial link	1 RJ45 (RS 232 - RS 485)		
	Networks	–	–	Ethernet, IEEE 802.3 10/100 BASE-T, RJ45
Downloadable protocols	Mitsubishi (Melsec®), Omron (Sysmac®), Rockwell Automation (Allen-Bradley), Siemens (Simatic®) Uni-TE™, Modbus®, Modbus TCP			
Development software	Vijeo Designer™ VJD●●●TG●V●●M (on Windows XP®, Windows Vista® and Windows 7) or Vijeo Designer Limited Edition			
Dimensions W x D x H	113x28x78mm		Front: 98x16x81mm Rear: 118x30x98mm	
	Compatibility with PLCs			
Compact Flash card slot	No			
USB port	1 Host type A + 1 Device type miniB			
Built-in Ethernet TCP/IP	No	No	Yes	
Supply voltage	24 VDC			
References	HMI STO511	HMI STO512	HMI STU655	



With matrix, semi-graphic screen

Type		Specifications			
Display	Capacity	2 lines, 20 characters		1 to 4 lines, 5 to 20 characters	
	Type	Back-lit LCD green		Back-lit LCD 3 colors green, orange, red	
Data entry		Via keypad with 8 keys (4 customizable keys)			
Function	Representation of variables	Alphanumeric	Alphanumeric, bargraph, curves, button and light		
	Alarm log	No	Yes	Yes	Yes
Communication	Serial link	1 RJ45 (RS 232 - RS 485)		1 Sub-D25 (RS 232 - RS 485) + 1 miniDin RS232 (2)	
Downloadable protocols		Uni-TE™, Modbus Master		Uni-TE, Modbus Master, Siemens, Rockwell, Omron, Mitsubishi, Zelio® (2)	
Development software		Vijeo Designer™ Lite (on Windows XP® and Windows Vista®)			
Dimensions W x D x H		132 x 37 x 74 mm			
Compatibility with PLCs		Twido®, Modicon TSX Micro™, Modicon Premium™, Modicon M340™		Twido, Modicon TSX Micro, Modicon Premium, Modicon Quantum, Modicon Momentum™, Modicon M340, Zelio® (2)	
Supply voltages		5 VDC or PLC power supply		24 VDC	
References		XBTN200	XBTN400	XBTN410	XBTN401

(1) Except XBTN200: alphanumeric screen.
 (2) For XBTN401 only



With matrix, semi-graphic screen, dedicated

Type		Specifications	
Display	Capacity	1 to 4 lines, 5 to 20 characters	
	Type	Back-lit LCD green	Back-lit LCD 3 colors (green, orange, red)
Data entry		Via keypad with 8 keys	
Function	Representation of variables	Alphanumeric, bargraph, curves, button and light	
	Alarm log	Yes	
Communication	Serial link	1 Sub-D25	1 miniDin RS232 + 1 Sub-D25
Downloadable protocols		Modbus®	Zelio®
Development software		Vijeo Designer™ Lite (on Windows XP® and Windows Vista®)	
Dimensions W x D x H		132 x 37 x 74 mm	
Compatibility with PLCs		Motor starter	Zelio
		Tesys® Model U	(including connection cable)
Supply voltages		24 VDC	
References		XBTNU400	XBTNSR2 (3)

(3) Including: 1 XBTN401 + 1 cable SR2CBL08 for Zelio

1



XBT N200



XBT N400/N410/NU400



XBT N401

Magelis® Small Panels

Downloadable exchange protocol	Compatible PLCs	Supply voltage	Type of screen	Reference	Weight kg
Terminal with 2 lines of 20 characters (with alphanumeric screen)					
Uni-TE™, Modbus®	Twido®, Nano™, TSX Micro™, Premium™, Modicon® M340™	5 V --- via PLC terminal port	Green backlit LCD	XBTN200	0.360
Terminals with 4 lines of 20 characters (with matrix screen)					
Uni-TE, Modbus	Twido, Nano, TSX Micro™, Premium, Modicon M340	5 V --- via PLC terminal port	Green backlit LCD (122 x 32 pixels)	XBTN400	0.360
	Twido (1), Nano, TSX Micro, Premium, TSX series 7, Momentum™, Quantum™ Other Modbus slave devices, Modicon M340	24 V --- external supply	Green backlit LCD (122 x 32 pixels)	XBTN410	0.380
Modbus	TeSys® model U motor starters (3) Altivar® drives	24 V --- external supply	Green, orange and red backlit LCD (2) (122 x 32 pixels)	XBTN401	0.380
			Green backlit LCD (122 x 32 pixels)	XBTNU400	0.380

Software

Description	Operating system	Reference
Configuration software	Windows 2000®, Windows XP®, and Windows Vista®	See pages 3/7 and 3/17

Accessories (4)

Description	Details	For use with	Reference	Weight kg
Flush mounting accessory	Kit for applications requiring a higher degree of dust and damp protection or customization of the panel, using a flat metal strip (not included)	All XBT N	XBTZN01	–
Protective sheets	10 peel-off sheets	All XBT N	XBTZN02	–
Sheets of re-usable labels	10 sheets of 6 labels	XBT N200/400	XBLYN00	–
		XBT N401 XBT NU400	XBLYN01	–
Mechanical adaptors for substitution of XBT H	From XBT H0●2●1/H0●1010 to XBT N410 From XBT H811050 to XBT N410	–	XBTZNC0	–

Connection cables and accessories (5)

Description	Compatibility	Types of connector	Physical link	Protocol	Length	Reference	Weight kg
Adaptor cable	XBT N200 XBT N400 (6)	RJ45-RJ45	RS 232C RS 485	Modbus®, Uni-TE™	0.1 m	XBTZN999	–
Zelio controller cable	XBTN401 XBTR411 XBTRT511	Zelio® SR2/ SR3	–	Zelio® Logic	2.5m	SR2CBL08	–

(1) Connection via integrated port or optional serial port on the Twido programmable controller.

(2) Also has 4 indicator LEDs.

(3) Factory preloaded application for monitoring, diagnostics and adjustment of 1 to 8 TeSys model U motor starters.

(4) Other accessories (see page 1/20).

(5) Other connection cables and accessories (see pages 1/20 to 1/23).

(6) Adaptor cable included with new version XBT N200/N400 terminals. The XBT ZN999 adaptor is for use with new version XBT N200/N400 terminals and the XBT Z978 cable (replaced by XBT Z9780), or with the old version XBT N200/N400 terminals and the new XBT Z9780 cable.

Note: The new version XBT N terminal can be distinguished externally from the old version as it has the Schneider Electric logo on the front panel (on the left above the screen).



With matrix, semi-graphic screen

Type		Specifications		
Display	Capacity	4 lines, 20 characters		
	Type	Back-lit LCD green	Back-lit LCD, 3 colors green, orange, red	
Data entry		Via keypad with 20 keys (12 customizable keys)		
Function	Representation of variables	Alphanumeric, bargraph, curves, button and light		
	Alarm log	Yes	Yes	Yes
Communication	Serial link	1 RJ45 (RS 232 - RS 485)	1 Sub-D25 (RS 232 - RS 485) + 1 miniDin (RS232)	
Downloadable protocols		Uni-TE™, Modbus® Master	Uni-TE, Modbus Master/Slave (1), Siemens, Rockwell, Omron, Mitsubishi, Zelio (1)	
Development software		Vijeo Designer™ Lite (on Windows XP® and Windows Vista®)		
Dimensions W x D x H		137 x 37 x 118 mm		
Compatibility with PLCs		Twido®, Modicon® TSX Micro™, Modicon Premium™, Modicon M340™	Twido, Modicon TSX Micro, Modicon Premium, Modicon® Quantum™, Modicon® Momentum™, Modicon M340, Zelio (1)	
Supply voltages		5 VDC or PLC power supply	24 VDC	
References		XBTR400	XBTR410	XBTR411

(1) For XBTR411 only

1



XBT R400/R410



XBT R411

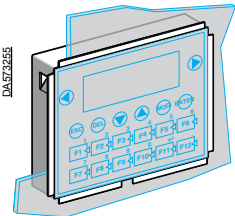

XBT ZR01

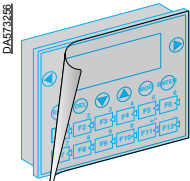

XBT ZR02

Magelis® Small Panels

Downloadable exchange protocol	Compatible PLCs	Supply voltage	Type of screen	Reference	Weight kg
Terminals with 4 lines of 20 characters (with matrix screen)					
Uni-TE™, Modbus®	Twido®, Nano, TSX Micro™, Premium™, Modicon® M340™	5 V $\overline{\text{---}}$ via PLC terminal port	Green backlit LCD (122 x 32 pixels)	XBTR400	0.550
	Twido (1), Nano, TSX Micro, Premium, TSX series 7, Momentum™, Quantum™	24 V $\overline{\text{---}}$ external supply	Green backlit LCD (122 x 32 pixels)	XBTR410	0.550
	Other Modbus slave devices, Modicon M340		Green, orange and red backlit LCD (2) (122 x 32 pixels)	XBTR411	0.550

Software

Description	Operating system	Reference
Configuration software	Windows 2000® and Windows XP®	See pages 3/7 and 3/17

Accessories (3)

Description	Details	For use with	Reference	Weight kg
Flush mounting accessory	Kit for applications requiring a higher degree of dust and damp protection or customization of the panel, using a flat metal strip (not included)	All XBT R	XBTZR01	–
Protective sheets	10 peel-off sheets	All XBT R	XBTZR02	–
Sheets of re-usable labels	10 sheets of 6 labels	XBT R400/R410	XBLYR00	–
		XBT R411	XBLYR01	–
Mechanical adaptor for substitution of XBT P	From XBT P01●010/P02●010 to XBT R410	–	XBTZRCO	–
	From XBT P02●110 to XBT R411			

(1) Connection via integrated port or optional serial port on the Twido PLC.

(2) Also has 16 indicator LEDs.

(3) Other accessories (see pages 1/20 to 1/23).

Equivalent product tables - XBT P terminals to XBT R terminals

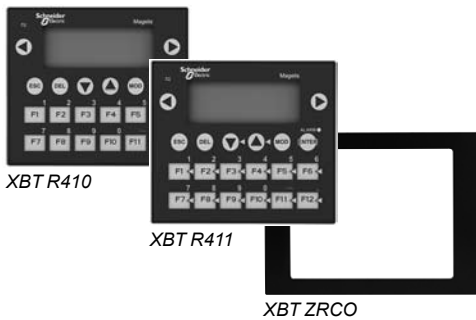

Old range XBT P	XBT R range	Mechanical adaptor (1)
XBTP011010	XBTR410	XBTZRCO
XBTP012010	XBTR410	XBTZRCO
XBTP021010	XBTR410	XBTZRCO
XBTP021110	XBTR411	XBTZRCO
XBTP022010	XBTR410	XBTZRCO
XBTP022110	XBTR411	XBTZRCO

(1) Mechanical adaptor for mounting XBT R terminal in place of the substituted XBT P terminal.

Equivalent product table - cables for connection to Schneider Electric PLCs

Summary		
Old range XBT P	XBT R range	
Type of link	Type of link	Cable
Serial port, 25-way SUB-D RS 232C/RS 485/RS 422	Serial port, 25-way SUB-D RS 232C/RS 485	Existing cable, see below
Printer port, 9-way SUB-D (model XBT P02110)	Printer port, 8-way mini-DIN (model XBT R411)	XBTZ926 (new cable)

Equivalent product table - cables

Old range XBT P				XBT R range			
Type of terminal	Type of link	Length	Reference	Type of terminal	Type of link	Length	Reference
Twido®, Modicon® TSX Micro™, Modicon® Premium™ , 8-way mini-DIN terminal port, Uni-TE™ (V1/V2), Modbus® protocol							
XBT P	RS 485 serial port, 25-way SUB-D	2.5 m	XBTZ968	XBT R	RS 485 serial port, 25-way SUB-D	2.5 m	XBTZ968
		5 m	XBTZ9681			5 m	XBTZ9681
		2.5 m angled	XBTZ9680			2.5 m angled	XBTZ9680
Modicon Premium with TSX SCY 2160 , 25-way female SUB-D connector, Uni-TE (V1/V2) protocol							
XBT P	RS 485 serial port, 25-way SUB-D	2.5 m	XBTZ918	XBT R	RS 485 serial port, 25-way SUB-D	2.5 m	XBTZ918
Modicon® Quantum™ , 9-way male SUB-D connector, Modbus protocol							
XBT P	RS 232C serial port, 25-way SUB-D	2.5 m	XBTZ9710	XBT R	RS 232C serial port, 25-way SUB-D	2.5 m	XBTZ9710
Advantys™ STB , HE13 connector (network interface module, NIM), Modbus protocol							
XBT P	RS 232C serial port, 25-way SUB-D	2.5 m	XBTZ988	XBT R	RS 232C serial port, 25-way SUB-D	2.5 m	XBTZ988
Modicon Momentum™ M1 , RJ45 connector (port 1), Modbus protocol							
XBT P	RS 232C serial port, 25-way SUB-D	2.5 m	XBTZ9711	XBT R	RS 232C serial port, 25-way SUB-D	2.5 m	XBTZ9711
TeSys® U starters, Altivar® 31/61/71 drives, Altistart® 48 starters , RJ45 connector, Modbus protocol							
XBT P	RS 485 serial port, 25-way SUB-D	2.5 m	XBTZ938	XBT R	RS 485 serial port, 25-way SUB-D	2.5 m	XBTZ938
LT6 P multifunction protection relay , 9-way female SUB-D connector, Modbus protocol							
XBT P	RS 232C serial port, 25-way SUB-D	2.5 m	XBTZ938	XBT R	RS 232C serial port, 25-way SUB-D	2.5 m	XBTZ938

Equivalent product table - cables for application transfer to PC and printer cable

Old range XBT P				XBT R range			
Type of terminal	Type of link	Length	Reference	Type of terminal	Type of link	Length	Reference
Cables for application transfer to PC							
XBT P	25-way SUB-D/ 9-way SUB-D	2.5 m	XBTZ915	XBT R	25-way SUB-D/ 9-way SUB-D	2.5 m	XBTZ915
	25-way SUB-D/USB	2.5 m	XBTZ915 + SR2CBL06 adaptor		25-way SUB-D/ USB	2.5 m	XBTZ915 + SR2CBL06 adaptor
Serial printer cable							
XBT P	Printer port, 9-way SUB-D	2.5 m	XBTZ936	XBT R	Printer port, 8-way mini-DIN	2.5 m	XBTZ926

1

Compatibility table - Downloadable third party protocols

PLC brand	Compatibility		Protocol name
	XBT P	XBT R	
Allen-Bradley	■	■	DF1/DH485
GE Fanuc	■	–	SNPX
Omron	■	■ (on RS 232)	Sysmac® Way
Siemens	■	■	PPI
	■	–	AS511, 3964R, MPI

Equivalent product table - Cables for connection to third party PLCs

Omron CQM1 & CVM1, Sysmac® PLCs

Old range XBT P					XBT R range				
Type of terminal	Type of connectors	Serial port	Length	Reference	Type of terminal	Type of connectors	Serial port	Length	Reference
Sysmac® Way protocol									
XBT P	25-way SUB-D/ 9-way SUB-D	RS 232	2.5 m	XBTZ9740	XBT R	25-way SUB-D/ 9-way SUB-D	RS 232C	2.5 m	XBTZ9740

Rockwell, Allen-Bradley PLCs

Old range XBT P					XBT R range				
Type of terminal	Type of connectors	Serial port	Length	Reference	Type of terminal	Type of connectors	Serial port	Length	Reference
DF1 protocol									
XBT P	25-way SUB-D/ 9-way SUB-D	RS 232C	2.5 m	XBTZ9730	XBT R	25-way SUB-D/ 9-way SUB-D	RS 232C	2.5 m	XBTZ9730
XBT P	25-way SUB-D/ AP PLC5	RS 232C	2.5 m	XBTZ9720	XBT R	25-way SUB-D/ AP PLC5	RS 232C	2.5 m	XBTZ9720
XBT P	25-way SUB-D/ AP	RS 232C	2.5 m	XBTZ9731	XBT R	25-way SUB-D/ AP Micro-logix	RS 232C	2.5 m	XBTZ9731
DH 485 point-to-point protocol									
XBT P	25-way SUB-D/ AP	RS 232C	2.5 m	XBTZ9732	XBT R	25-way SUB-D/ AP Micro-logix	RS 232C	2.5 m	XBTZ9732
DH 485 multidrop protocol									
XBT P	25-way SUB-D/ SLC500 with AIC gateway	RS 232C	2.5 m	XBTZ9730	XBT R	25-way SUB-D/ AP SLC5 with AIC gateway	RS 232C	2.5 m	XBTZ9732

Siemens Simatic® PLCs

Old range XBT P					XBT R range				
Type of terminal	Type of connectors	Serial port	Length	Reference	Type of terminal	Type of connectors	Serial port	Length	Reference
PPI (S7) protocol									
XBT P	25-way SUB-D/ 9-way SUB-D	RS 485	2.5 m	XBTZ9721	XBT R	25-way SUB-D/ 9-way SUB-D	RS 485	2.5 m	XBTZ9721

Equivalent product table - Connection to Uni-Telway™ serial link

Old range XBT P					XBT R range				
Type of terminal	Type of connectors	Serial port	Length	Reference	Type of terminal	Type of connectors	Serial port	Length	Reference
On subscriber socket TSX SCA 62									
XBT P	25-way SUB-D/ 15-way SUB-D	RS 485	1.8 m	XBTZ908	XBT R	25-way SUB-D/ 15-way SUB-D	RS 485	1.8 m	XBTZ908
On cable connector TSX P ACC 01									
XBT P	25-way SUB-D/ 8-way mini-DIN	RS 485	2.5 m 5 m	XBTZ968 XBTZ9681	XBT R	25-way SUB-D/ 8-way mini-DIN	RS 485	2.5 m 5 m	XBTZ968 XBTZ9681

Equivalent product table - Connection to Modbus® serial link

Old range XBT P					XBT R range				
Type of terminal	Type of connectors	Serial port	Length	Reference	Type of terminal	Type of connectors	Serial port	Length	Reference
On subscriber socket TSX SCA 64									
XBT P	25-way SUB-D/ 15-way SUB-D	RS 485/ RS422	1.8 m	XBTZ908	XBT R	25-way SUB-D/ 15-way SUB-D	RS 485/ RS422	1.8 m	XBTZ908
On 8 port splitter box LU9 GC3									
XBT P	25-way SUB-D/RJ45	RS 485	2.5 m	XBTZ938	XBT R	25-way SUB-D/RJ45	RS 485	2.5 m	XBTZ938



With semi-graphic and touchscreen

Type		Specifications	
Display	Capacity	10 lines, 33 characters	
	Type	Back-lit LCD green	Back-lit LCD green, orange, red
Data entry		Via keypad with 12 keys (10 customizable keys) or touchscreen	
Functions	Representation of variables	Alphanumeric, bargraph, curves, button and light	
	Alarm log	Yes	Yes
Communication	Serial link	1 RJ45 (RS 232 - RS 485) + 1 miniDin (RS232) (2)	
Downloadable protocols		Uni-TE™, Modbus® Master, Siemens, Rockwell, Omron, Mitsubishi	
Development software		Vijeo Designer™ Lite (on Windows XP® and Windows Vista®)	
Dimensions W x D x H		137 x 37 x 118 mm	
Compatibility with PLCs		Twido®, Modicon® TSX Micro™, Modicon Premium™, Modicon M340™, Modicon Quantum™, Zelio® (1)	
Supply voltages		5 VDC or PLC power supply	24 VDC
References		XBTRT500	XBTRT511

(1) For XBTRT511 only

1



XBT RT500



XBT RT511

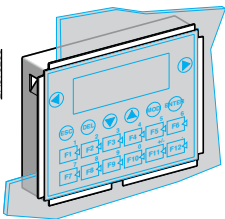

XBT ZR01

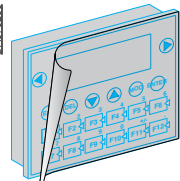

XBT ZR02

Magelis Small Panels

Downloadable exchange protocol	Compatible PLCs	Supply voltage	Type of screen	Reference	Weight kg
Terminal with 10 lines of 30 characters (with matrix screen)					
Uni-TE™, Modbus®	Twido®, Nano, TSX Micro™, Premium™, Modicon® M340™	5 V $\overline{\text{---}}$ via PLC terminal port	Green backlit LCD (198 x 80 pixels)	XBTRT500	0.550
	Twido, Nano, TSX Micro™, Premium, TSX Series 7, Momentum™, Quantum™, other Modbus slave devices, Modicon M340	24 V $\overline{\text{---}}$ external supply	Green, orange and red backlit LCD (198 x 80 pixels) + 13 indicator LEDs + buzzer	XBTRT511	–

Software

Description	Operating system	Reference
Configuration software	Windows 2000®, Windows XP® and Windows Vista®	See pages 3/7 and 3/17

Accessories (1)

Description	Details	For use with	Reference	Weight kg
Flush mounting accessory	Kit for applications requiring a higher degree of dust and damp protection or customization of the panel, using a flat metal strip (not included)	All XBTRT	XBTZR01	–
Protective sheets	10 peel-off sheets	All XBTRT	XBTZR02	–
Sheets of re-usable labels	10 sheets of 6 labels	XBTRT500	XBLYRT00	–
		XBTRT511	XBLYRT01	–
Mechanical adaptor for substitution XBT P/PM		–	XBTZRCO	–

Description	Compatibility	Type of connector	Physical link	Protocol	Length m	Reference	Weight kg
Downloading adaptor (2)	XBTRT500	RJ45-RJ45	RS 485	Modbus	0.2	XBTZRT999	–
Zelio controller cable	XBTN401 XBTR411 XBTRT511	Zelio SR2/SR3	–	Zelio® Logic	2.5m	SR2CBL08	–

(1) Other accessories, see page 1/21.
Other connection cables and accessories, see pages 1/21 to 1/23.
(2) Also included in kit XBT Z.945.

Operator dialog terminals

Separate parts for Magelis® XBT N/R/RT Small Panels

Accessories				
Type	Compatibility	Sold in lots of	Unit reference	Weight kg
External 5 V adaptor (1)	XBT N200/N400 XBT R400 XBT RT500	1	XBT ZRT PW	–
XBT RT downloading adaptor (2)	XBT RT500/511	1	XBT ZRT999	–
Spring clips (replacement parts)	XBT N/R/RT/GT	12	XBT Z3002	0.200
Power supply connector	XBT N/R/RT	10	XBT Z3004	0.200

Connection to PCs and printers					
Use	Compatibility	Length	Connector, peripheral end	Reference	Weight kg
Cables for PC connection, RS 232C serial port	XBT N401/N410/NU400 XBT R410/R411	2.5 m	9-pin male SUB-D	XBT Z915	0.200
	XBT N200/N400/R400 XBT RT500/RT511	2.5 m	9-pin male SUB-D and mini-DIN (PS/2)	XBT Z945	0.200
USB cable for PC connection (3)	XBT N/R/RT	–	USB type A male	TSX CUSB 485	–
XBT adaptor for USB cable	XBT N/R/RT	2 m	Set of 2 cables RJ45/RJ45 RJ45/25-pin SUB-D	XBT Z925	–
Serial printer cable	XBT N/R/RT	2.5 m	25-pin female SUB-D	XBT Z926	0.220

(1) Use a 5 V power supply: ABL 8MEM 05040.

(2) Cable XBT Z945 included.

(3) Adaptor XBT Z925 to be used with the cable.

Operator dialog terminals

Separate parts for Magelis® XBT N/R/RT Small Panels

1

Cables for connecting Magelis® terminals

Type of PLC to be connected	Type of connector	Physical link	Protocol	Length	Reference	Weight kg	
Direct connection of terminals XBT N/R/RT (XBT N200/N400/R400/RT500/RT511) to Schneider Electric PLCs							
Twido®, Modicon® Nano™, Modicon® TSX Micro™, Modicon® Premium™	Mini-DIN	RS 485	Modbus®/ Uni-TE™	2.5 m	XBT Z9780	–	
				10 m	XBT Z9782 (1)	–	
Modicon® M340™	RJ45	RS 485	Modbus®	2.5 m	XBT Z9980	–	
				10 m	XBT Z9982 (1)	–	
Direct connection of terminals XBT N/R (XBT N410/N401/R410/R411) to Schneider Electric PLCs							
Twido, Modicon Nano, Modicon TSX Micro, Modicon Premium	Terminal port, 8-pin female mini-DIN	RS 485	Uni-TE (V1/V2) and Modbus	2.5 m	XBT Z968	0.180	
				5 m	XBT Z9681	0.340	
				2.5 m (2)	XBT Z9680	0.170	
Modicon Premium with TSX SCY 2160●	25-pin female SUB-D	RS 485	Uni-TE (V1/V2)	2.5 m	XBT Z918	0.230	
Modicon® Quantum™	9-pin male SUB-D	RS 232	Modbus	2.5 m	XBT Z9710	0.210	
Advantys™ STB	HE13 (NIM)	RS 232	Modbus	2.5 m	XBT Z988	0.170	
Modicon® Momentum™ M1 (Port 1)	RJ45	RS 232	Modbus	2.5 m	XBT Z9711	0.210	
Modicon M340	RJ45	RS 485	Modbus	2.5 m	XBT Z938	0.210	
Direct connection of terminals XBT N/R/RT (XBT N401/R411/RT511) to Schneider Electric PLCs via the 2nd mini-DIN serial port and Vijeo Designer™ Lite 1.3 minimum							
Zelio® Logic	Programming port	–	Zelio	3 m	SR2 CBL 08	–	
Direct connection of terminals XBT RT500/RT511 to Advantys™ STB I/O (3)							
Advantys™ STB	HE13 (NIM)	RS 232	Modbus	2.5 m	XBT Z9715	–	
Direct connection of terminals XBT (XBT NU400/N410/N401/R410/R411) to Schneider Electric motor starters and drives							
Starter-controllers TeSys® U, T Drives Altivar® 31/38/58/71 Soft starter ATS 48 Lexium® 05, Preventa™ XPSMC	RJ45	RS 485	Modbus	2.5 m	XBT Z938	0.210	
Direct connection of terminals XBT (XBT N200/N400/R400/RT500/RT511) to Schneider Electric motor starters and drives (4)							
Starter-controllers TeSys U, T Drives Altivar® 31/38/58/71 Soft starter ATS 48 Lexium 05, Preventa XPSMC	RJ45	RS 485	Modbus	2.5 m	XBT Z9980	–	
Direct connection of terminals XBT (XBT N410/N401/R410/R411) to third party PLCs							
Allen-Bradley	SLC5	9-pin male SUB-D	RS 232	DF1	2.5 m	XBT Z9730	0.210
	PLC5	25-pin female SUB-D	RS 232	DF1	2.5 m	XBT Z9720	0.210
	Micro-logix	Micro-logix 1000	RS 232	DF1	2.5 m	XBT Z9731	0.210
				DH485	2.5 m	XBT Z9732	–
Mitsubishi	FX	8-pin female Mini-DIN	RS 232/ RS 422 converter	Melsec FX	2.5 m	XBT Z980	–
Omron	CPM1, CPM2, CJ1, CS1	9-pin male SUB-D	RS 232	Sysmac® Way	2.5 m	XBT Z9740	0.210
Siemens	S7 (PG)	9-pin male SUB-D	RS 485	PPI	2.5 m	XBT Z9721	0.210

(1) For XBT N200/N400/R400/RT500 use cable with adaptor **XBT ZRT PW** and a 5 V power supply.

(2) Elbowed SUB-D connector.

(3) For XBT RT500 use a cable with adaptor **XBT ZRT PW** and a 5 V power supply.

(4) For Magelis XBT N200/N400/R400/RT500 use a cable with adaptor **XBT ZRT PW** and a 5 V power supply.

Operator dialog terminals

Separate parts for Magelis® XBT N/R/RT Small Panels

Cables for connecting Magelis® terminals (continued)

Direct connection of terminals XBT RT500/ RT511 to third party PLCs (1)

Allen-Bradley	SLC5	9-pin male SUB-D	RS 232	DF1	2.5 m	XBT Z9734	–
	Micro-logix	Micro-logix 1000	RS 232	DF1	2.5 m	XBT Z9733	–
Mitsubishi	FX	8-pin female Mini-DIN	RS 232/ RS 422	Melsec FX converter	2.5 m	XBT Z980 + (2)	–
Omron	CPM1, CPM2, CJ1, CS1	9-pin male SUB-D	RS 232	Sysmac® Way	2.5 m	XBT Z9743	–
Siemens	S7 (PG)	9-pin male SUB-D	RS 485	PPI	2.5 m	XBT ZG9721	0.210

Bus and network connections for terminals XBT N410/N401/R410/R411

Type of bus/network	Tap-off units	Type of connector	Length	Reference	Weight kg
Uni-Telway™ serial link	Subscriber socket TSX SCA 62	15-pin female SUB-D	1.8 m	XBT Z908	0.240
	Connection box TSX P ACC 01	8-pin female mini-DIN	2.5 m	XBT Z968	0.180
			5 m	XBT Z9681	0.340
Modbus® serial link	Subscriber socket TSX SCA 64	15-pin female SUB-D	1.8 m	XBT Z908	0.240
	8 port Modbus splitter box LU9 GC3, Modbus tap-off, TWD XCA ISO, TWD XCA T3RJ	RJ45	2.5 m	XBT Z938	0.210

Bus and network connections for terminals XBT RT511

Type of bus/network	Tap-off units	Type of connector	Length	Reference	Weight kg
Uni-Telway serial link	Connection box TSX P ACC 01	8-pin female mini-DIN	2.5 m	XBT Z9780	0.180
Modbus serial link	8 port Modbus splitter box LU9 GC3, Modbus tap-off, TWD XCA ISO, TWD XCA T3RJ	RJ45	2.5 m	XBT Z9980	–



(1) For XBT RT500 use a cable with adaptor XBT ZRT PW and a 5 V power supply.

(2) Adaptor XBT ZG939 to be used with cables with "+" (3)" after the reference.

Operator dialog terminals

Magelis® XBT GT, XBT GK, XBT GH, XBT GTW Advanced Panels

1

Applications		Display of text messages, graphic objects and synoptic views Control and parametering of data		
Type of terminal		Touch screen Advanced Panels		
				
Display	Type	Back-lit monochrome (amber or red mode) STN LCD (320 x 240 pixels) or TFT LCD	Back-lit monochrome or color STN LCD or back-lit color TFT LCD (320 x 240 pixels)	Back-lit color STN LCD or TFT LCD (640 x 480 pixels)
	Size	3.8" (monochrome or color)	5.7" (monochrome or color)	7.5" (color)
Data entry		Via touch screen		
		–		
		–		
		–		
		–		
Memory capacity	Application	32 MB Flash EPROM	16 MB Flash EPROM	32 MB Flash EPROM
	Expansion	–	By 128, 256, 512 MB, 1, 2 or 4 GB CF card (except XBT GT2110)	
Functions	Maximum number of pages	Limited by internal Flash EPROM memory capacity	Limited by internal Flash EPROM memory capacity or CF card memory capacity	
	Variables per page	Unlimited (8000 variables max.)		
	Representation of variables	Alphanumeric, bitmap, bargraph, gauge, tank, tank level indicator, curves, polygon, button, light		
	Recipes	32 groups of 64 recipes comprising 1024 ingredients max.		
	Curves	Yes, with log		
	Alarm logs	Yes		
	Real-time clock	Built-in		
	Digital inputs/outputs	–	1 input (reset) and 3 outputs (alarm, buzzer, run)	
	Multimedia inputs/outputs	–	1 audio input (microphone), 1 composite video input (digital or analog camera), 1 audio output (loudspeaker) (1)	
	Communication	Downloadable protocols	Uni-TE™ (2), Modbus®, Modbus TCP/IP (1) and for PLC brands: Mitsubishi, Omron, Allen-Bradley and Siemens	
Asynchronous serial link		RS 232C/RS 485 (COM1)	RS 232C/RS 422/485 (COM1) and RS 485 (COM2)	
USB ports		1	1	2
Bus and networks		–	Modbus Plus™ and Fipway® with USB gateway, Profibus DP and DeviceNet™ with optional card	
		Ethernet TCP/IP (10BASE-T/100BASE-TX) (1)		
Printer link		USB port for parallel printer	RS 232C (COM1) serial link, USB port for parallel printer	
Development software		Vijeo Designer™ (page 3/17) (on Windows XP® and Windows Vista®)		
Operating system		Magelis® (200 MHz RISC CPU)	Magelis (133 MHz RISC CPU)	Magelis (266 MHz RISC CPU)
Terminal type		XBT GT11/13	XBT GT21/22/23	XBT GT42/43
Pages		1/32	1/34	1/36

(1) Depending on model.

(2) Uni-TE version V2 for Twido controller and TSX Micro/Premium platform.

Touch screen Advanced Panels



Back-lit color STN LCD or TFT LCD (640 x 480 pixels)

10.4" (color)



Back-lit color TFT LCD (800 x 600 pixels)

12.1" (color)



Back-lit color TFT LCD (1024 x 768 pixels)

15" (color)

Via touch screen

-
-
-
-

32 MB Flash EPROM

By 128, 256, 512 MB, 1, 2 or 4 GB Compact Flash card

Limited by internal Flash EPROM memory capacity or CF card memory capacity

Unlimited (8000 variables max.)

Alphanumeric, bitmap, bargraph, gauge, tank, tank level indicator, curves, polygon, button, light

32 groups of 64 recipes comprising 1024 ingredients max.

Yes, with log

Yes

Built-in

1 input (reset) and 3 outputs (alarm, buzzer, run)

1 audio input (microphone), 1 composite video input (digital or analog camera), 1 audio output (loudspeaker) (1)

Uni-TE™ (2), Modbus®, Modbus TCP/IP (1) and for PLC brands: Mitsubishi, Omron, Allen-Bradley and Siemens

RS 232C/RS 422/485 (COM1) and RS 485 (COM2)

2

Modbus Plus™ with USB gateway

Ethernet TCP/IP (10BASE-T/100BASE-TX)

RS 232C (COM1) serial link, USB port for parallel printer

Vijeo Designer™ (page 3/17) (on Windows XP® and Windows Vista®)

Magelis®
(266 MHz RISC CPU)

XBT GT52/53

XBT GT63

XBT GT73

1/37

1/39

1/39

Operator dialog terminals

Magelis® XBT GT, XBT GK, XBT GH, XBT GTW
Advanced Panels

1

Applications

Display of text messages, graphic objects and synoptic views
Control and parametering of data

Type of terminal

Advanced Panels with keypad



Display

Type	Color TFT LCD (320 x 240 pixels) or monochrome STN LCD	Color TFT LCD (640 x 480 pixels)
Size	5.7" (monochrome or color)	10.4" (color)

Type	Color TFT LCD (320 x 240 pixels) or monochrome STN LCD	Color TFT LCD (640 x 480 pixels)
Size	5.7" (monochrome or color)	10.4" (color)

Data entry

Static function keys	10	12
Dynamic function keys	14	18
Service keys	8	
Alphanumeric keys	12	

Via keypad and/or touch screen (configurable) and/or by industrial pointer

Static function keys	10	12
Dynamic function keys	14	18
Service keys	8	
Alphanumeric keys	12	

Memory capacity

Application	16 MB Flash EPROM	32 MB Flash EPROM
Expansion	By 128, 256, 512 MB, 1, 2 or 4 GB Compact Flash card	

Application	16 MB Flash EPROM	32 MB Flash EPROM
Expansion	By 128, 256, 512 MB, 1, 2 or 4 GB Compact Flash card	

Functions

Maximum number of pages	Limited by internal Flash EPROM memory capacity or CF card memory capacity	
Variables per page	Unlimited (8000 variables max.)	
Representation of variables	Alphanumeric, bitmap, bargraph, gauge, tank, tank level indicator, curves, polygon, button, light	
Recipes	32 groups of 64 recipes comprising 1024 ingredients max.	
Curves	Yes, with log	
Alarm logs	Yes	
Real-time clock	Built-in	
Digital inputs/outputs	-	1 input - 3 outputs
Multimedia inputs/outputs	-	-

Maximum number of pages	Limited by internal Flash EPROM memory capacity or CF card memory capacity	
Variables per page	Unlimited (8000 variables max.)	
Representation of variables	Alphanumeric, bitmap, bargraph, gauge, tank, tank level indicator, curves, polygon, button, light	
Recipes	32 groups of 64 recipes comprising 1024 ingredients max.	
Curves	Yes, with log	
Alarm logs	Yes	
Real-time clock	Built-in	
Digital inputs/outputs	-	1 input - 3 outputs
Multimedia inputs/outputs	-	-

Communication

Downloadable protocols	Uni-TE™ (2), Modbus®, Modbus TCP/IP (1) and for PLC brands: Mitsubishi, Omron, Allen-Bradley and Siemens	
Asynchronous serial link	RS 232C/RS 422/485 (COM1) RS 485 (COM2)	
USB ports	1	2
Bus and networks	Modbus Plus™, Fipway® with USB gateway, Profibus DP and DeviceNet™ with optional card Ethernet TCP/IP (10BASE-T/100BASE-TX)	
Printer link	RS 232C (COM1) serial link, USB port for parallel printer	

Downloadable protocols	Uni-TE™ (2), Modbus®, Modbus TCP/IP (1) and for PLC brands: Mitsubishi, Omron, Allen-Bradley and Siemens	
Asynchronous serial link	RS 232C/RS 422/485 (COM1) RS 485 (COM2)	
USB ports	1	2
Bus and networks	Modbus Plus™, Fipway® with USB gateway, Profibus DP and DeviceNet™ with optional card Ethernet TCP/IP (10BASE-T/100BASE-TX)	
Printer link	RS 232C (COM1) serial link, USB port for parallel printer	

Development software
Operating system

Vijeo Designer™ (page 3/17) (on Windows XP® and Windows Vista®)
Magelis®
(266 MHz RISC CPU)

Terminal type

XBT GK 21/23	XBT GK 53
---------------------	------------------

Pages

1/41	1/42
------	------

(1) Depending on model.

(2) Uni-TE version V2 for Twido controller and TSX Micro/Premium platform.

**Display of text messages, graphic objects and synoptic views
Control and parametering of data**

Portable Advanced Panels Open touch screen Advanced Panels



Color TFT LCD (640 x 480 pixels)	Color TFT LCD (800 x 600 pixels)	Color TFT LCD (800 x 600 pixels)	Color TFT LCD (1024 x 768 pixels)
5.7" (color)	8.4" (color)	12" (color)	15" (color)

Via touch screen	Via touch screen		
11	–		
–	–		
–	–		
–	–		

32 MB Flash EPROM	1 GB CF system card included with terminal, expandable to 4 GB	2 GB CF system card included with terminal, expandable to 4 GB	
By 128, 256, 512 MB, 1, 2 or 4 GB Compact Flash card			

Limited by internal Flash EPROM memory capacity or CF card memory capacity
Unlimited (8000 variables max.)

Alphanumeric, bitmap, bargraph, gauge, tank, tank level indicator, curves, polygon, button, light
32 groups of 64 recipes comprising 1024 ingredients max.

Yes, with log
Yes

Built-in
–

1 audio output

Uni-TE™ (2), Modbus®, Modbus TCP/IP and for PLC brands: Mitsubishi, Omron, Rockwell Automation and Siemens	Uni-TE (2), Modbus®, Modbus TCP/IP (1) and for PLC brands: Mitsubishi, Omron, Allen-Bradley and Siemens		
--	---	--	--

RS 232C/RS 422-485 (COM1)	RS 232C (COM1) RS 232C (COM2)	RS 232C (COM1)	RS 232C (COM1) RS 232C (COM2)
---------------------------	----------------------------------	----------------	----------------------------------

1	4	4 + 1 front mounted	
–	Modbus Plus™ with USB gateway		

1 Ethernet port (10BASE-T/100BASE-TX)	1 Ethernet TCP/IP port (10BASE-T/100BASE-TX) and 1 Ethernet port (10BASE-T/100BASE-TX/1 GB)		
–	RS 232C (COM1 or COM2) serial link, USB port for parallel printer		

Vijeo Designer™ (page 3/17) (on Windows XP® and Windows Vista®)

Magelis® (266 MHz RISC CPU)	Windows XP® Embedded
--------------------------------	----------------------

XBT GH 2460 XBT GTW 450 XBT GTW 652 XBT GTW 750

1/44	1/47	1/47	1/48
------	------	------	------

(1) Depending on model.
(2) Uni-TE version V2 for Twido controller and TSX Micro/Premium platform.

Operator dialog terminals

Magelis® XBT GT, XBT GK, XBT GH, XBT GTW
Advanced Panels

Introduction



Touch screen terminals with monochrome or color screen in 6 sizes from 3.8" to 15"

The Magelis® offer includes:

- Range of 16 touch screen terminals (XBT GT) available with a wide choice of screen sizes (3.8", 5.7", 7.5", 10.4" 12.1" and 15") in various versions (monochrome, color, STN or TFT).
- Range of 3 keypad/touch screen terminals (XBT GK), sizes 5.7" and 10.4" (monochrome, color).
- Range of 2 open touch screen terminals (XBT GTW), sizes 8.4" and 15" with Windows XP Embedded for open access to new automation functions.
- Portable touch screen terminal (XBT GH) with 5.7" color screen and safety devices (emergency stop, enabling grip switch, etc.).

Operation

Magelis XBT terminals feature new information and communication technologies which, depending on model, include:

- High level of communication (on-board Ethernet, multilink, Web server and FTP).
- External storage of data (Compact Flash memory card and USB Memory Stick) for storing production data and backing up applications.
- Multimedia data with integrated image and sound management (digital or analog camera).
- Peripheral management: printers, bar code readers, loudspeakers, etc.



Video sequence display

Configuration

Magelis® XBT terminals can be configured using Vijeo Designer™ VJD ●●D TGS V●●M software, in a Windows XP® or Windows Vista® environment. The advanced ergonomics of the Vijeo Designer VJD ●●D TGS V●●M software, designed around several functional windows, enables quick and simple development of a project. This version enables composite video signal processing from a camera or camcorder. See pages 3/8 to 3/10.

Communication

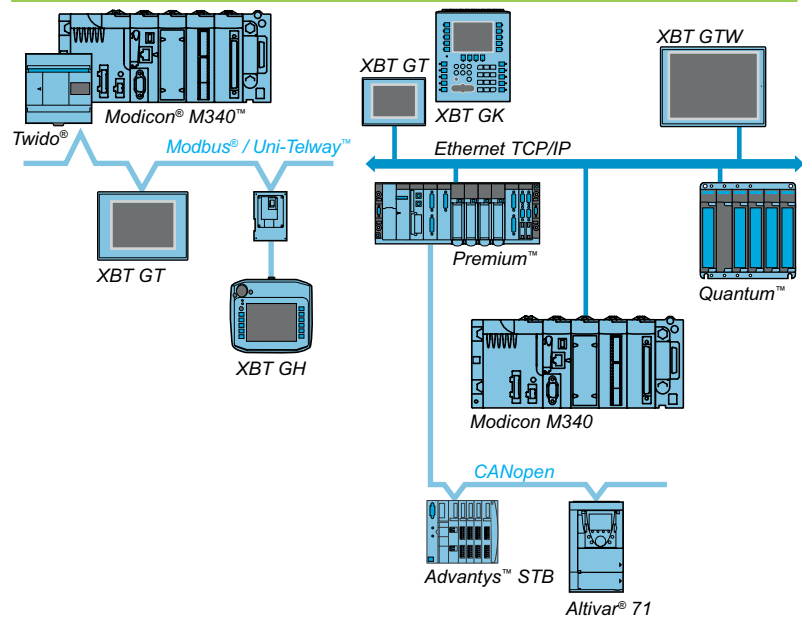

Magelis® XBT terminals communicate with PLCs via one or two integrated serial links, using communication protocols:

- Schneider Electric (Uni-TE™, Modbus®)
- Third party: Mitsubishi Electric, Omron, Allen-Bradley and Siemens

Magelis multifunction terminals can be connected, depending on the model, to Ethernet TCP/IP networks using Modbus TCP or third party protocols, and to fieldbuses (FIPWAY®, Modbus Plus™, DeviceNet™, Profibus DP).

Functions

Magelis® XBT terminals provide the following functions:

- display of animated synoptic views with 8 types of animation (pressing touch panel, changing of color, filling, movement, rotation, size, visibility and value display),
 - control, modification of numeric and alphanumeric variables,
 - display of date and time,
 - real-time and trending curves with log,
 - alarm display, alarm log and management of alarm groups,
 - multiwindow management,
 - operator initiated page calls,
 - multilingual application management (10 languages at the same time),
 - recipes management,
 - data processing via Java script,
 - application and log storage on external Compact Flash application memory card (multifunction range) or USB key,
 - serial printer and bar code reader management (multifunction range),
 - sound messages management (multifunction range),
- composite video signal management from camera or camcorder on XBT GT and digital video signal (Webcam) management on XBT GTW.

XBT terminals have been designed for Transparent Ready® architectures and equipment (combination of Web and Ethernet TCP/IP technologies).

Therefore, all terminals with an Ethernet port integrate an FTP server for data file transfer and a Web Gate function for remote access to the application of the XBT terminal from a PC with an Internet browser.

The latest version of Vijeo Designer™ therefore allows terminal XBT to browse HTML pages.

The flexibility of embedded Windows XP® enables Internet Explorer® or Microsoft Office® Readers (.pdf, .doc, .xls, .ppt documents) to be used on XBT GTW touch screen/open terminals while a Vijeo Designer™ application is running.

Operating modes of the terminals

The following illustrations show the equipment that can be connected to XBT terminals according to their two operating modes.

Editing mode

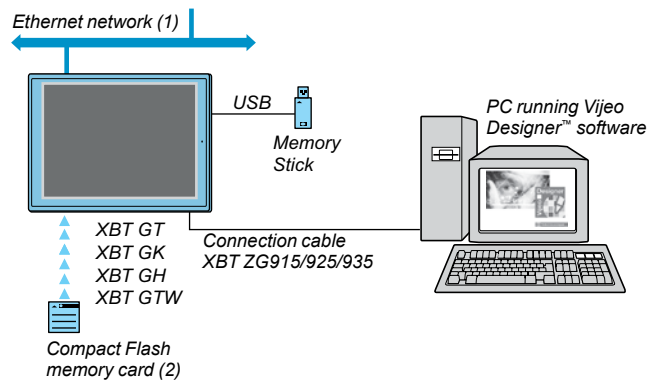

Operating mode

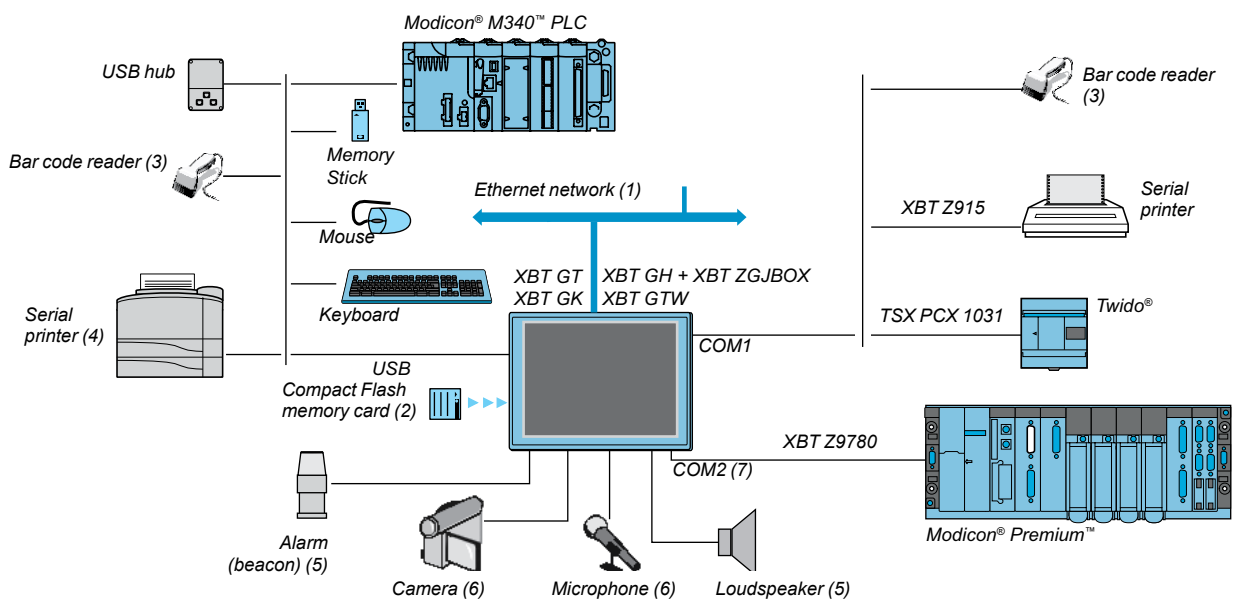

- (1) With XBT GT●●30/XBT GT●●40, XBT GK●●30/XBT GTW●●●0/XBT GH2460.
- (2) Memory card, except XBT GT11/13/2110.
- (3) Validated with DataLogic Gryphon bar code reader.
- (4) Validated with Hewlett Packard printer via USB/PIO converter.
- (5) With all XBT GT, XBT GK and XBT GTW multifunction 7.5" to 15".
- (6) With multimedia XBT GT 7.5" to 15" XBT GT●340.
- (7) With XBT GT and XBT GK 5.7" mini screen.

Improve environmental resistance with Conformal Coating

The Conformal Coating service offer consists of varnishing the electronic cards to prolong the service life of the terminals and allow their use in corrosive environments. The varnishing increases resistance to condensation, dusty atmospheres and chemical corrosion (sulphurous and halogenous atmospheres).

For further information on this offer, please consult our Customer Care Center.

Description

Magelis® XBT GT1105/1135/1335 Advanced Panels

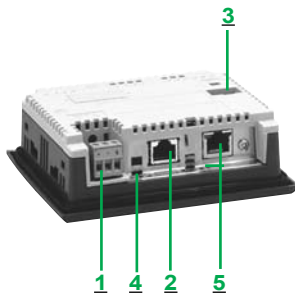

Front panel

The front panels of Magelis® XBT GT1105/1135/1335 Advanced Panels feature:

- 1 Touch screen for displaying synoptic views (3.8" amber or red mode monochrome, color TFT)
- 2 Control lamp indicating the operating mode of the terminal

Rear panel

The rear panels of Magelis® XBT GT1105/1135/1335 Advanced Panels include:

- 1 Removable screw terminal block for the 24 V $\bar{\bar{}}$ power supply
- 2 RJ45 connector for RS 232C or RS 485 serial link connection to PLCs (COM1)
- 3 USB type A host connector for connecting peripherals, transferring applications and Modicon® M340™ terminal port communication
- 4 Switch for polarization of the serial link, used on RS 485 Modbus®

On XBT GT1135/1335 only

- 5 RJ45 connector for Ethernet TCP/IP link, 10/100BASE-T

Operator dialog terminals

Magelis® XBT GT Advanced Panels with 3.8" screen



Type		Specifications		
Display	LCD screen size / Resolution	3.8" / QVGA		
	Type	STN monochrome, amber or red	TFT 256 color	
Functions	Representation of variables	Alphanumeric, bitmap, bargraph, gauge, button, light, clock, flashing light, keypad		
	Curves / Alarm logs	Yes, with log / Yes, incorporated		
Communication	Serial link	1 RJ45 (RS 232 - RS 485)		
	Networks	–	Ethernet, IEEE 802.3 10/100 BASE-T, RJ45	
Downloadable protocols	Mitsubishi (Melsec®), Omron (Sysmac®), Rockwell Automation (Allen-Bradley), Siemens (Simatic®), Uni-TE™, Modbus®, Modbus TCP			
Development software	Vijeo Designer™ VJD●●●TG●V●●M (on Windows XP®, Windows Vista® and Windows 7)			
Dimensions W x D x H	130 × 41 × 104 mm			
Compatibility with PLCs	Twido®, Modicon® TSX Micro™, Modicon Premium™, Modicon Quantum™, Modicon M340™			
Compact Flash card slot	No			
USB port Host type A	1	1	1	
Built-in Ethernet TCP/IP	No	Yes		
Supply voltage	24 VDC			
References	XBTGT1105	XBTGT1135	XBTGT1335	

Operator dialog terminals

Magelis® XBT GT Advanced Panels with 5.7" screen

1

Description

Magelis® XBT GT2110 and multifunction XBT GT2●20 & XBT GT2●30 Advanced Panels

The front panel features:

- 1 Touch screen for displaying synoptic views (5.7" monochrome or color)
- 2 Multicolor lamp (green, orange and red) indicating the operating mode of the terminal

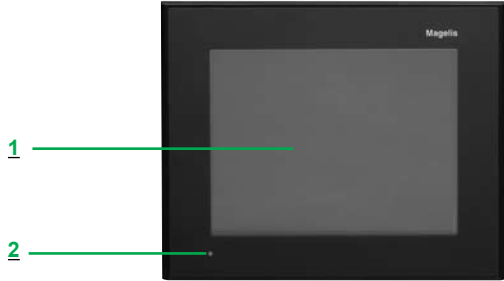

The rear panel includes:

- 1 Removable screw terminal block for the 24 V $\overline{\text{DC}}$ power supply
- 2 USB type A host connector for connecting peripherals, transferring applications and Modicon® M340™ terminal port communication
- 3 9-way male SUB-D connector for RS 232C or RS 422/485 serial link to PLCs (COM1)
- 4 Expansion unit interface for fieldbus communication card (DeviceNet, Profibus DP) (1)
- 5 Switch for polarization of the COM2 serial link, used on Modbus®
- 6 RJ45 connector for RS 485 serial link (COM2)
- 7 Compact Flash memory card slot, with cover (except XBT GT2110 optimum model).

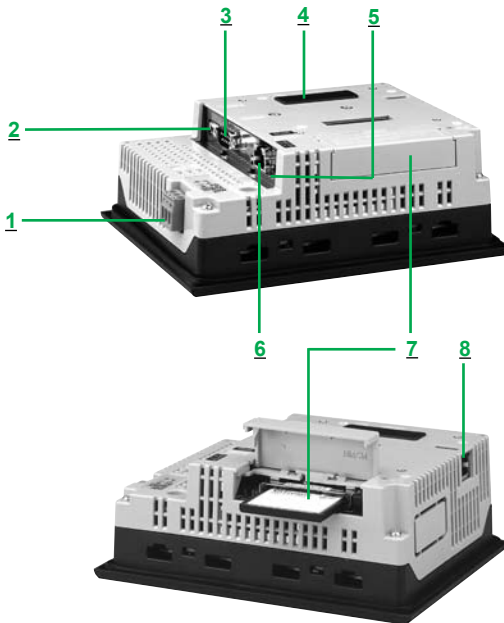

On XBT GT2130 and GT2330 only:

- 8 RJ45 connector for Ethernet TCP/IP link, 10BASE-T/100BASE-TX

(1) Connection accessories required (see pages 1/55 to 1/59).

Operator dialog terminals

Magelis® XBT GT Advanced Panels with 5.7" screen



Type		Specifications						
Display	LCD screen size / Resolution	5.7" / QVGA					5.7" / VGA	
	Type	STN Monochrome Blue backlighting		Black and White backlighting		STN, color 4096 colors	TFT, color 65536 colors High brightness backlighting	
Functions	Representation of variables	Alphanumeric, bitmap, bargraph, gauge, button, light, clock, flashing light, keypad						
	Curves / Alarm logs	Yes, with log / Yes, incorporated						
Communication	Serial link	1 Sub-D9 (RS 232/RS 422 - RS 485) + 1 RJ45 (RS 485)						
	Networks	-	-	Ethernet, IEEE 802.3 10/100 BASE-T, RJ45	-	Ethernet, IEEE 802.3 10/100 BASE-T, RJ45	Ethernet 10/100 BASE-T	Ethernet, IEEE 802.3 10/100 BASE-T, RJ45
Downloadable protocols		Mitsubishi (Melsec®), Omron (Sysmac®), Rockwell Automation (Allen-Bradley), Siemens (Simatic®) Uni-TE™, Modbus®, Modbus TCP/IP						
Development software		Vijeo Designer™ VJD●●●TG●V●●M (on Windows XP®, Windows Vista® and Windows 7)						
Dimensions W x D x H		167.5 × 60 × 135 mm						
Compatibility with PLCs		Twido®, Modicon® TSX Micro™, Modicon Premium™, Modicon Quantum™, Modicon M340™, Modicon Momentum™						
Compact Flash card slot		No	Yes					
USB port Host type A		1					2	
Video in		No						
Built-in Ethernet TCP/IP		No	No	Yes	No	Yes	Yes	Yes
Supply voltage		24 VDC						
References		XBTGT2110	XBTGT2120	XBTGT2130	XBTGT2220	XBTGT2330	XBTGT2930	XBTGT2430

Operator dialog terminals

Magelis® XBT GT Advanced Panels with 7.5" screen

1

Description

Magelis® XBT GT4230 & 4300 Advanced Panels

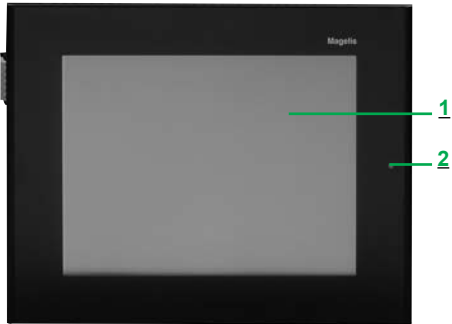

The front panel features:

- 1 Touch screen for displaying synoptic views (7.5" color STN or 7.5" color TFT, depending on the model)
- 2 Multicolor lamp (green, orange and red) indicating the operating mode of the terminal

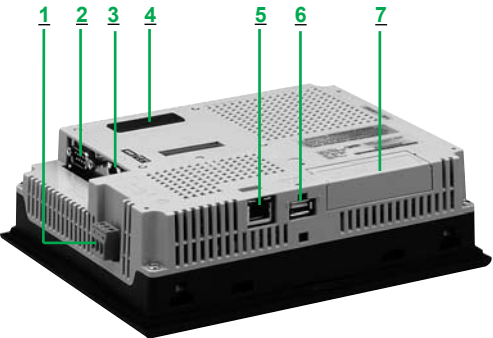

The rear panel includes:

- 1 Removable screw terminal block for the 24 V $\bar{\bar{}}$ power supply
- 2 9-way male SUB-D connector for RS 232C or RS 422/485 serial link to PLCs (COM1)
- 3 RJ45 connector for RS 485 serial link (COM2) with switch for polarization of the link used on Modbus®
- 4 Expansion unit interface for fieldbus communication card (DeviceNet, Profibus DP) (1)
- 5 RJ45 connector for Ethernet TCP/IP link, 10BASE-T/100BASE-TX, with an activity LED
- 6 USB type A host connector for connecting peripherals, transferring applications and Modicon® M340™ terminal port communication
- 7 Slot for Compact Flash memory card, with pivoting cover
- 8 Removable I/O connector, 12 spring terminals for loudspeaker connection, one input (reset) and 3 outputs (alarm, buzzer, run).



On XBT GT4340 only:

- 9 Mini-jack connector for connecting a microphone
- 10 RCA connector for connecting a digital or analog video camera (NTSC/PAL)

(1) Connection accessories required (see pages 1/55 to 1/59).

Operator dialog terminals

Magelis® XBT GT Advanced Panels with 10.4" screen

Description

Magelis® XBT GT5230 & XBT GT5300 Advanced Panels

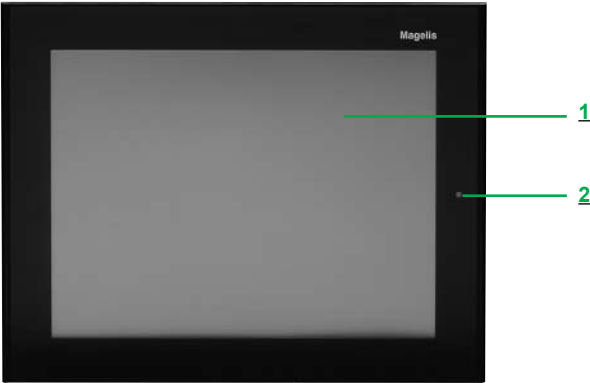

The front panel features:

- 1 Touch screen for displaying synoptic views (10.4" color STN or 10.4" color TFT, depending on model)
- 2 Multicolor lamp (green, orange and red) indicating the operating mode of the terminal

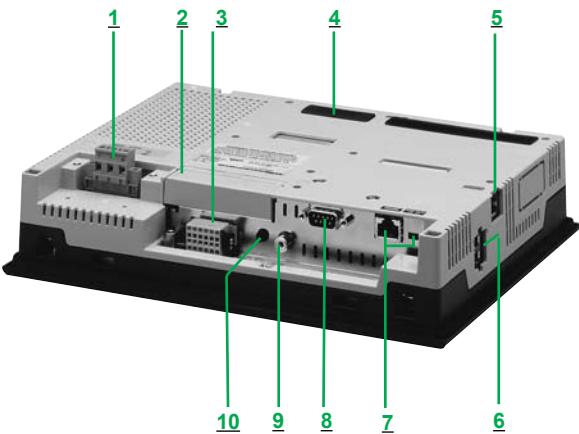

The rear panel includes:

- 1 Removable screw terminal block for the 24 V $\bar{\text{---}}$ power supply
- 2 Slot for Compact Flash memory card, with pivoting cover
- 3 Removable I/O connector (1), 12 spring terminals for loudspeaker connection, one input (reset) and 3 outputs (alarm, buzzer, run).
- 4 Expansion unit interface for fieldbus communication card (DeviceNet, Profibus DP) (2)
- 5 RJ45 connector for Ethernet TCP/IP link, 10BASE-T/100BASE-TX with an activity LED
- 6 Two USB type A host connectors for connecting peripherals, transferring applications and Modicon® M340™ terminal port communication
- 7 RJ45 connector for RS 485 serial link (COM2) with switch for polarization of the link used on Modbus®
- 8 9-way male SUB-D connector for RS 232C or RS 422/485 serial link to PLCs (COM1)

On XBT GT5340 only:

- 9 Mini-jack connector for connecting a microphone
- 10 RCA connector for connecting a digital or analog video camera (NTSC/PAL)

(1) On the XBT GT5230 model, this removable connector is located on the rear panel of the terminal.

(2) Connection accessories required (see pages 1/55 to 1/59).

Operator dialog terminals

Magelis® XBT GT Advanced Panels with 7.5" and 10.4" screen

1



Type		Specifications						
Display	LCD screen size / Resolution	7.5" / VGA			10.4" / VGA			10.4" / SVGA
	Type (color)	STN	TFT	TFT	STN	TFT	TFT	TFT
	Number of colors	4096	65536	65536	4096	65536	65536	65536
Functions	Representation of variables	Alphanumeric, bitmap, bargraph, gauge, button, light, clock, flashing light, keypad						
	Curves / Alarm logs	Yes, with log / Yes, incorporated						
Communication	Serial link	1 Sub-D9 (RS 232/RS 422 - RS 485) + 1 RJ45 (RS 485)						
	Networks	Ethernet, IEEE 802.3 10/100 BASE-T, RJ 45						
Downloadable protocols		Mitsubishi (Melsec®), Omron (Sysmac®), Rockwell Automation (Allen-Bradley), Siemens (Simatic®) Uni-TE™, Modbus®, Modbus TCP/IP						
Development software		Vijeo Designer™ VJD●●●TG●V●●M (on Windows XP®, Windows Vista® and Windows 7)						
Dimensions W x D x H (mm)		215x60x170		313x56x239		271x57x213		
Compatibility with PLCs		Twido®, Modicon® TSX Micro™, Modicon Premium™, Modicon Quantum™, Modicon M340™						
Compact Flash card slot		Yes						
USB port Host type A		1	1	1	2	2	2	2
Video in		No	No	Yes	No	No	Yes	No
Built-in Ethernet TCP/IP		Yes						
Supply voltage		24 VDC						
References		XBTGT4230	XBTGT4330	XBTGT4340	XBTGT5230	XBTGT5330	XBTGT5340	XBTGT5430

Operator dialog terminals

Magelis® XBT GT Advanced Panels with 12.1" and 15" screen

Description

Magelis® XBT GT6300 & XBT GT7340 Advanced Panels

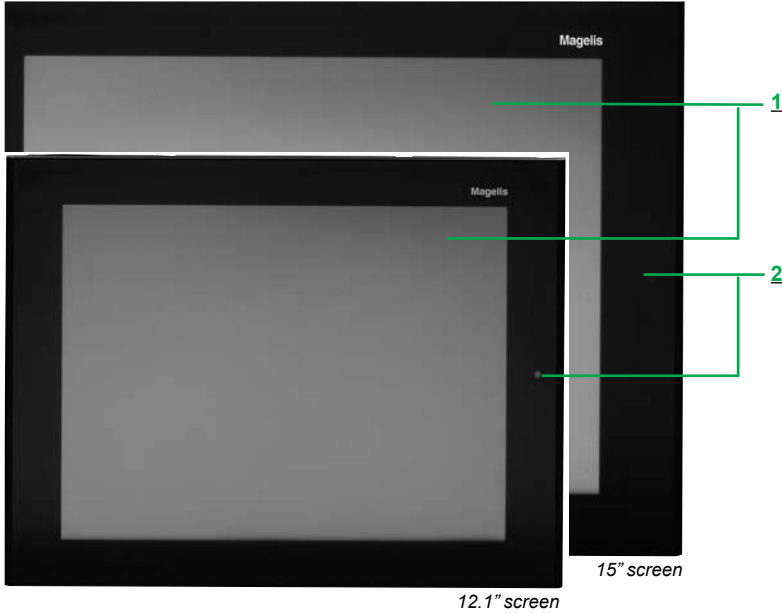

The front panel features:

- 1 Touch screen for displaying synoptic views (12.1" or 15" color TFT, depending on model)
- 2 Multicolor lamp (green, orange and red) indicating the operating mode of the terminal

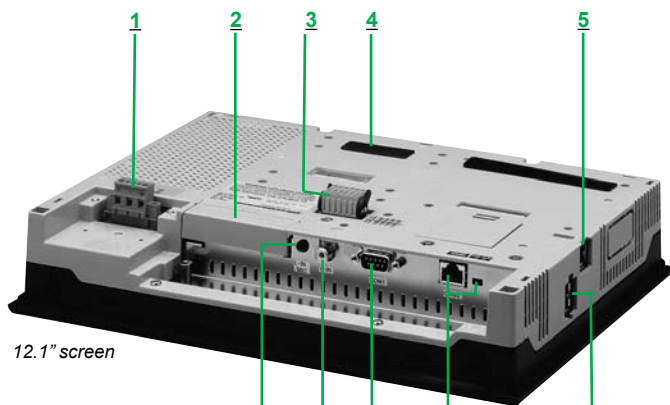

The rear panel includes:

- 1 Removable screw terminal block for the 24 V $\bar{\text{~}}$ power supply
- 2 Slot for Compact Flash memory card, with pivoting cover
- 3 Removable I/O connector, 12 spring terminals for loudspeaker connection, one input (reset) and 3 outputs (alarm, buzzer, run).
- 4 Expansion unit interface for fieldbus communication card (DeviceNet, Profibus DP) (1)
- 5 RJ45 connector for Ethernet TCP/IP link, 10BASE-T/100BASE-TX, with an activity LED
- 6 Two USB type A host connectors for connecting peripherals, transferring applications and Modicon® M340™ terminal port communication
- 7 RJ45 connector for RS 485 serial link (COM2) with switch for polarization of the link used on Modbus®
- 8 9-way male SUB-D connector for RS 232C or RS 422/485 serial link to PLCs (COM1)

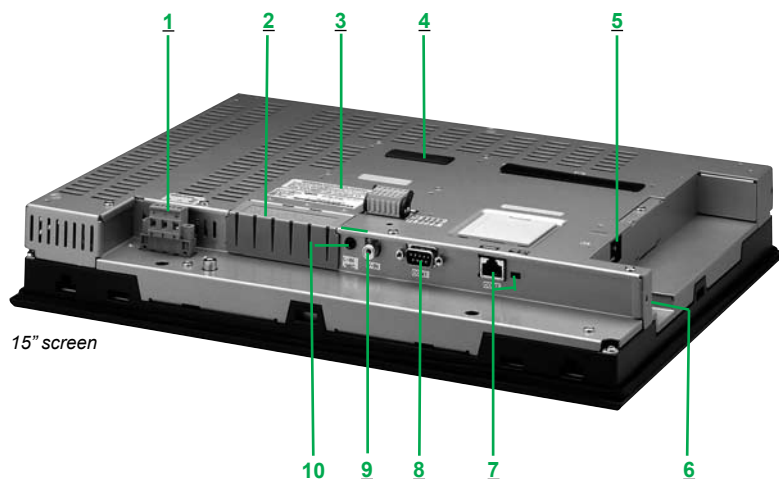

On XBT GT6340 and XBT GT7340 only:

- 9 Mini-jack connector for connecting a microphone
- 10 RCA connector for connecting a digital or analog video camera (NTSC/PAL)

(1) Connection accessories required (see pages 1/55 to 1/59).

Operator dialog terminals

Magelis® XBT GT Advanced Panels with 12.1" and 15" screen

1



Type		Specifications		
Display	LCD screen size / Resolution	12,1" / SVGA		15" / XGA
	Type (color)	TFT	TFT	TFT
	Number of colors	65536	65536	65536
Functions	Representation of variables	Alphanumeric, bitmap, bargraph, gauge, button, light, clock, flashing light, keypad		
	Curves / Alarm logs	Yes, with log / Yes, incorporated		
Communication	Serial link	1 Sub-D9 (RS 232/RS 422 - RS 485) + 1 RJ45 (RS 485)		
	Networks	Ethernet, IEEE 802.3 10/100 BASE-T, RJ 45BASE-T, RJ 45		
Downloadable protocols	Mitsubishi (Melsec®), Omron (Sysmac®), Rockwell Automation (Allen-Bradley), Siemens (Simatic®), Uni-TE™, Modbus®, Modbus TCP/IP			
Development software	Vijeo Designer™ VJD●●●TG●V●●M (on Windows XP®, Windows Vista® and Windows 7)			
Dimensions W x D x H (mm)	313x56x239		395x60x294	
Compatibility with PLCs	Twido®, Modicon® TSX Micro™, Modicon Premium™, Modicon Quantum™, Modicon M340™			
Compact Flash card slot	Yes			
USB port Host type A	2			
Video in	No	Yes	Yes	
Built-in Ethernet TCP/IP	Yes			
Supply voltage	24 VDC			
References	XBTGT6330	XBTGT6340	XBTGT7340	

Operator dialog terminals

Magelis® XBT GK Advanced Panels with 5.7" screen





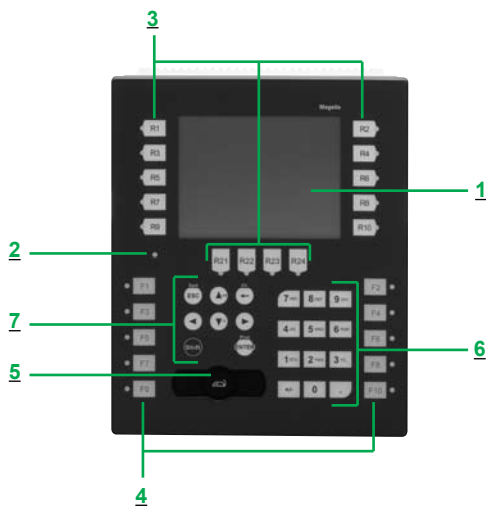



Details

Magelis® XBT GK2120 & XBT GK2330 Advanced Panels



The front panel features:

- 1 Touch screen for displaying synoptic views (5.7" monochrome or color) configurable using Vijeo® Designer™ software
- 2 Multicolor lamp (green, orange and red) indicating the operating mode of the terminal
- 3 14 dynamic keys (Ri) with 3-color LED (green, orange, red)
- 4 10 static keys (Ri) with 3-color LED (green, orange, red) and customizable labels
- 5 Industrial pointer "  ", configurable using Vijeo Designer™
- 6 12 alphanumeric keys (0...9, +/-, .) with successive pressing to access characters (A...Z)
- 7 8 service keys:

-  Delete the character to the left of the cursor
-  Move the cursor to the right or left in an input field
-  Confirm a selection or an entry
-  Access the second of the functions marked on the key
-  Increment or decrement a numeric field value or activate the next or previous object
-  Exit Entry Mode
-  Display the terminal configuration menu
-  Copy the current screen
-  Delete the whole field

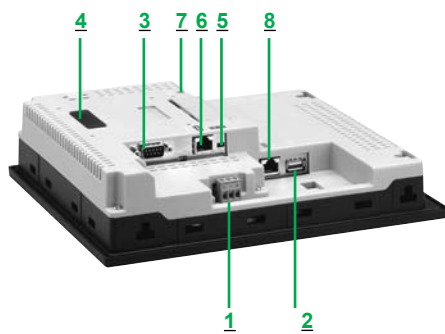

The rear panel includes:

- 1 removable screw terminal block for 24 V $\overline{\text{DC}}$ power supply
- 2 USB type A host connector for connecting peripherals, transferring applications and Modicon® M340™ terminal port communication
- 3 9-way male SUB-D connector for RS 232C or RS 422/485 serial link to PLCs (COM1)
- 4 Expansion unit interface for fieldbus communication card (Profibus DP, DeviceNet™) (1)
- 5 Switch for polarization of the COM2 serial link, used on Modbus®
- 6 RJ45 connector for RS 485 serial link (COM2)
- 7 Slot for Compact Flash memory card, with cover

On GK2330 only:

- 8 RJ45 connector for Ethernet TCP/IP link, 10BASE-T/100BASE-TX

(1) Connection accessories required (see pages 1/55 to 1/59).

Operator dialog terminals

Magelis® XBT GK Advanced Panels with 10.4" screen

1

Description

Magelis® XBT GK5330 Advanced Panels

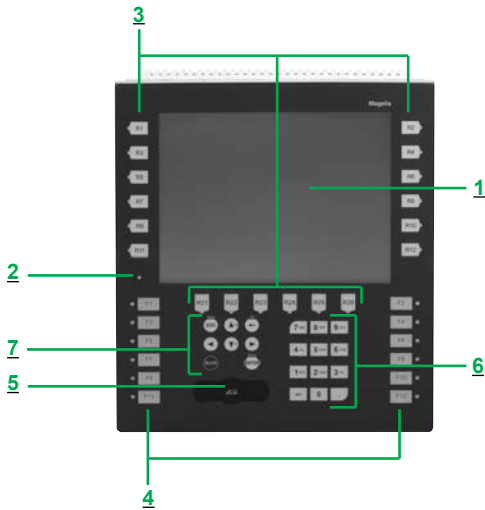

The front panel includes:

- 1 Touch screen for displaying synoptic views (10.4" color TFT) configurable using Vijeo® Designer™ software
- 2 Multicolor lamp (green, orange and red) indicating the operating mode of the terminal
- 3 18 dynamic keys (Ri) with 3-color LED (green, orange, red)
- 4 12 static keys (Fi) with 3-color LED (green, orange, red) and customizable labels
- 5 Industrial pointer "Ⓐ" , configurable using Vijeo Designer
- 6 12 alphanumeric keys (0...9, +/-. ,) with successive pressing to access characters (A...Z)
- 7 8 service keys:

- Delete the character to the left of the cursor
- Move the cursor to the right or left in an input field
- Confirm a selection or an entry
- Access the second of the functions marked on the key
- Increment or decrement a numeric field value or activate the next or previous object
- Exit Entry Mode
- Display the terminal configuration menu
- Copy the current screen
- Delete the whole field

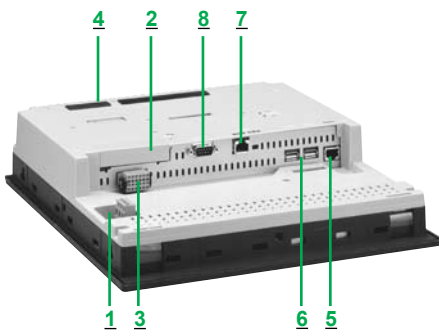

The rear panel features:

- 1 Removable screw terminal block for 24 V $\bar{\bar{}}$ power supply
- 2 Slot for Compact Flash memory card, with pivoting cover
- 3 Removable I/O connector, 12 spring terminals for loudspeaker connection, one input (reset) and 3 outputs (alarm, buzzer, run)
- 4 Expansion unit interface for fieldbus communication card (DeviceNet™, Profibus DP)
- 5 RJ45 connector for Ethernet TCP/IP link, 10BASE-T/100BASE-TX with an activity LED
- 6 Two USB type A host connectors for connecting peripherals, transferring applications and Modicon® M340™ terminal port communication
- 7 RJ45 connector for RS 485 serial link (COM2) with switch for polarization of the link used on Modbus®
- 8 9-way male SUB-D connector for RS 232C or RS 422/485 serial link to PLCs (COM1)

Operator dialog terminals

Magelis® XBT GK Advanced Panels with 5.7" and 10.4" screen



Type		Specifications		
Display	Screen size / Resolution	5.7" / QVGA		10.4" / VGA
	Type	STN monochrome black and white	TFT Color 65536 colors	
Data entry	Soft function keys with LED	14		18
	Static function keys with LED	10 + legends		12 + legends
	Service keys / Alphanumeric keys	8 / 12		
	Touchscreen and industrial pointer	Yes		
Functions	Representation of variables	Alphanumeric, bitmap, bargraph, gauge, button, light, clock, flashing light, keypad		
	Curves	Yes, with log		
	Alarm logs	Yes		
Communication	Serial link	1 Sub-D9 (RS 232/RS 422 - RS 485) + 1 RJ45 (RS 485)		
	Networks	-	Ethernet, IEEE 802.3 10/100 BASE-T, RJ 45	
Downloadable protocols	Mitsubishi (Melsec®), Omron (Sysmac®), Rockwell Automation (Allen-Bradley), Siemens (Simatic®), Uni-TE™, Modbus®, Modbus TCP/IP			
Development software	Vijeo Designer™ VJD●●●TG●V●●M (on Windows XP®, Windows Vista® and Windows 7)			
Compact Flash card slot	Yes			
Dimensions W x D x H	220.3x88x265mm	296x91x332mm	197x92.6x147mm	
Compatibility with PLCs	Twido®, Modicon® TSX Micro™, Modicon Premium™, Modicon Quantum™, Modicon M340™			
USB port	1	1	2	
Video in	No	No	No	
Built-in Ethernet TCP/IP	No	Yes		
Supply voltage	24 VDC			
References	XBTGK2120	XBTGK2330	XBTGK5330	

Operator dialog terminals

Magelis® XBT GH Advanced Panels with 5.7" screen

1

Description

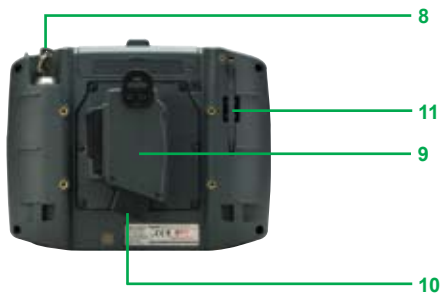
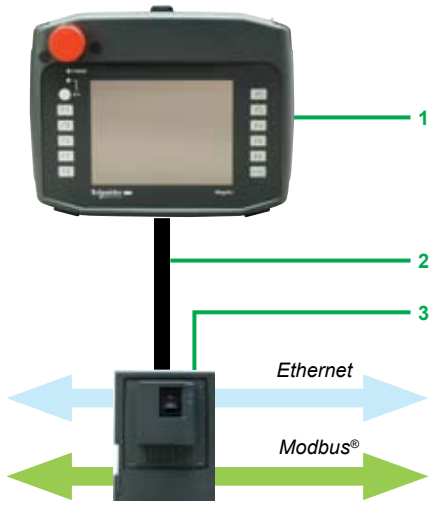

Overview

The Magelis® XBT GH2460 **1** is a hand-held graphic terminal with a 5.7" touch screen. It enables connection on the Ethernet network or Modbus at each point where a junction box XBT ZGJBOX **3** is installed.

Connection between the terminal and junction box is made by an XBT ZGHL3 or XBT ZGHL10 cable **2**.

Magelis® Advanced Panels XBT GH2460

Front panel features:

- 1** Graphical display touch screen (5.7" color), configurable using Vijeo® Designer™ software.
- 2** Multicolor LED (green, orange and red) indicating the operating mode of the terminal.
- 3** 11 function keys Fi.
- 4** Operating button with O.P. signalling LED (green) for touch screen validation.
- 5** Emergency stop button with 2 NC safety contacts and 1 NO auxiliary contact for stopping the machine if required.

Rear panel features:

- 6** A type USB host connector for peripheral connection, application transfer (with protective cover).
- 7** Slot for Compact Flash memory card (also protected by the cover).
- 8** Power On/Off key switch for the Magelis XBT GH
- 9** 3-position enabling grip switch. The OK signal is only sent when the grip is in the center position.
- 10** 24-pin connector for plugging-in the 3 m or 10 m flexible interface cable between the Magelis XBT GH and the junction box.
- 11** Stylus for the touch screen.
- 12** Two holes for inserting changeable legends on the function keys.

Description (continued)

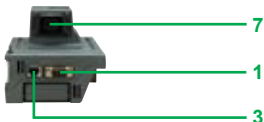

Magelis® Junction box XBT ZGJBOX for XBT GH

It includes:

- 1 9-pin SUB-D connector for RS 232C or RS 422/485 serial link to PLCs (COM1).
- 2 Power On/Off switch for the junction box.
- 3 RJ45 connector for Ethernet TCP/IP, 10BASE-T/100BASE-TX link.
- 4 24-way screw terminal block for connecting the 24 V supply and output signals from the Magelis XBT GH terminal.
- 5 Link status LED with the Magelis XBT GH, 3 colors (green, orange and red).
- 6 2 coding wheels for configuring the station number on the junction box.
- 7 24-pin connector for connecting the Magelis XBT GH terminal using the 3 m or 10 m (XBT ZGHL3 or XBT ZGHL10) flexible cable.

Flexible cables XBT ZGHL3 and XBT ZGHZ10

For connecting the Magelis XBT GH terminals to their XBT ZGJBOX junction box.

Operator dialog terminals

Magelis® XBT GH Advanced Panels with 5.7" screen

1



Type		Specifications
Display	Screen size / Resolution	5.7" / VGA
	Type (color)	TFT
	Number of colors	65 536
Data entry	Function keys	11 + label
	Operaton key	1 with LED (validation touchscreen)
Safety components	Key Switch	Yes for ON/OFF
	3 positions Enable switch	Yes, OK signal in intermediate position only
	Emergency stop	Yes, red with 2 safe contacts and one auxiliary contact
Functions	Representation of variables	Alphanumeric, bitmap, bargraph, gauge, button, light, clock, flashing light, keypad
	Curves / Alarm historic	Yes, with log / Yes, incorporated
Connection		24-pins connector (communication, alimentation, I/O)
Downloadable protocols		Mitsubishi (Melsec®), Omron (Sysmac®), Rockwell Automation (Allen-Bradley), Siemens (Simatic®) Uni-TE™, Modbus®, Modbus TCP/IP
Development software		Vjeco Designer™ VJD●●●TG●V●●M (on Windows XP®, Windows Vista® and Windows 7)
Compact Flash card slot		Yes
Dimensions W x D x H (mm)		224 x 174 x 87.1
USB port		1
Supply voltage		24 VDC
Reference		XBT GH2460
Type of connector		2 x 24-pins speed connectors
Length		3 m 10 m
Reference		XBTZGHL3 XBTZGHL10
Communcation	Serial link	1 SubD9 (RS232 / RS422 - RS 425)
	Network	1 Ethernet RJ45 IEEE 802.3 10/100 T-BASE,
Connection	24 pins connector	Interface cable 3 or 10 m
	Screw terminals blocks	For alimentation 24 VDC, state of I/O safety components
Reference		XBTZGJBOX

Operator dialog terminals

Magelis® XBT GTW Advanced Panels with 8.4" and 12" screen



Magelis® XBT GTW terminals

8.4" touch screen front panel, XBT GTW 450

The touch screen front panel of terminal **XBT GTW 450** features:

- 1 8.4" SVGA active matrix color TFT LCD screen (maximum display area 800 x 600 points) with high definition analog touch panel.
- 2 Aluminum alloy front panel with IP 65 membrane (mounted on a treated steel frame).
- 3 Two LEDs marked:
 - ON (green), terminal on,
 - DISK (green), accessing IDE bus (accessing Compact Flash memory, etc.).

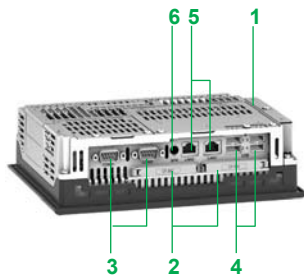

Lower faces, 8.4"

All expansion slots and connection elements are accessible from the rear of the terminal, with the following elements located on the lower face:

- 1 Removable screw terminal block for connecting --- 24 V power supply.
- 2 Two Compact Flash memory card slots, one for the card containing the operating system and integrated software, and the other open.
- 3 Two 9-pin male SUB-D connectors marked COM1 and COM2 for the RS 232 serial link.
- 4 Four USB 2.0 ports.
- 5 Two RJ45 connectors for Ethernet 10/100 Mps and Ethernet 10/100 Base-TX/ 1 GB link.
- 6 Mini-jack connector for loudspeaker.

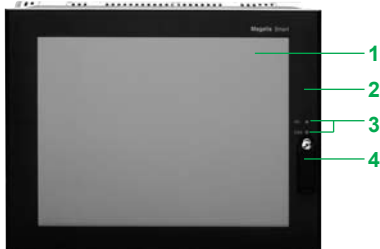

12" touch screen front panel, XBT GTW 652

The touch screen front panel of terminal **XBT GTW 652** features:

- 1 15" SVGA active matrix color TFT LCD screen (maximum display area 800 x 600 points) with high definition analog touch panel.
- 2 Aluminum alloy front panel with IP 65 membrane (mounted on a treated steel frame).
- 3 Two LEDs marked:
 - ON (green), terminal on,
 - DISK (green), accessing IDE bus (accessing Compact Flash memory, etc.).
- 4 Dust and moisture protected USB port.

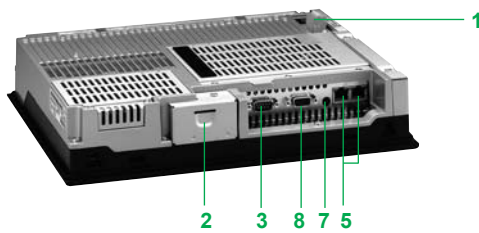

Lower faces and side, 12"

All expansion slots and connection elements are accessible from the rear of the terminal, with the following elements located on the lower face:

- 1 Removable screw terminal block for connecting --- 24 V power supply.
- 2 Slot for the Compact Flash memory card containing the operating system and integrated software.
- 3 25-pin female SUB-D connector marked RAS for product monitoring and diagnostics.
- 4 Two 9-pin male SUB-D connectors marked COM1 and COM2 for the RS 232 serial link.
- 5 Four USB 2.0 ports.
- 6 Mini-DIN PS/2 connector for connecting external keyboard.
- 7 Two RJ45 connectors for Ethernet 10/100 Mbps and Ethernet 10/100 Base-TX/ 1 GB link.
- 8 Slot for 2 additional type II PCMCIA cards.
- 9 Mini-jack connector for loudspeaker.

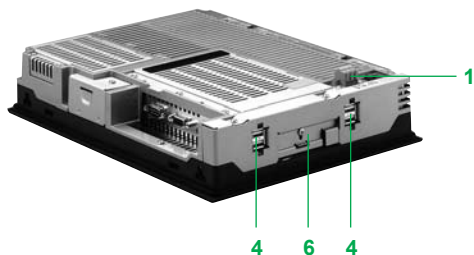

Operator dialog terminals

Magelis® XBT GTW Advanced Panels with 15" screen

1

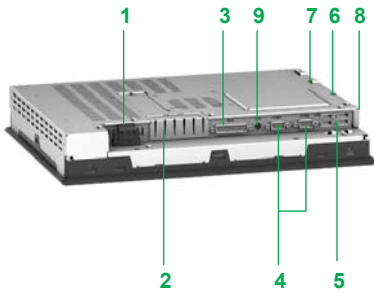
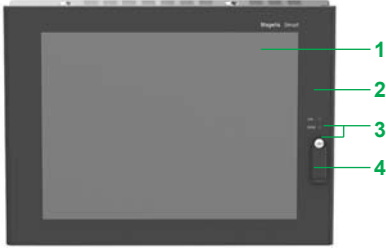

Magelis® XBT GTW terminals

15" touch screen front panel, XBT GTW 750

The touch screen front panel of terminal **XBT GTW 750** features:

- 1 15" XGA active matrix color TFT LCD screen (maximum display area 1024 x 768 points) with high definition analog touch panel.
- 2 Aluminum alloy front panel with IP 65 membrane (mounted on a treated steel frame).
- 3 Two LEDs marked:
 - ON (green), terminal on,
 - DISK (green), accessing IDE bus (accessing Compact Flash memory, etc.).
- 4 Dust and moisture protected USB port.

Lower faces, 15"

All expansion slots and connection elements are accessible from the rear of the terminal, with the following elements located on the lower face:

- 1 Removable screw terminal block for connecting $\overline{\text{---}}$ 24 V power supply.
- 2 Slot for the Compact Flash memory card containing the operating system and integrated software.
- 3 25-pin female SUB-D connector marked RAS for product monitoring and diagnostics.
- 4 Two 9-pin male SUB-D connectors marked COM1 and COM2 for the RS 232 serial link.
- 5 Four USB 2.0 ports.
- 6 Mini-DIN PS/2 connector for connecting external keyboard.
- 7 Two RJ45 connectors for Ethernet 10/100 Mbps and Ethernet 10/100 Base-TX/1 GB link.
- 8 Slot for 2 additional type II PCMCIA cards.
- 9 Mini-jack connector for loudspeaker.

Pre-installed software

In addition to Windows XP® Embedded, terminals XBT GTW also have the following software on the Compact Flash System card:

- Vijeo Designer™ Run Time, unlimited use after activation of authorization code
- Vijeo® Citect® Web Client dll on XBT GTW652/750
- Internet Explorer®.
- Adobe® Acrobat® Reader.
- Microsoft® Word/Excel®/PowerPoint® viewer
- Framework .Net® on XBT GTW 652 and 750

Operator dialog terminals

Magelis® XBT GTW Advanced Panels with 8.4", 12" and 15" screen



Type	Specifications		
Pre-installed Software	OS: Windows XP® Embedded, Internet Explorer®, Microsoft Office®, Adobe® Acrobat® Reader, .NET®, Vijeo Designer™ Run Time unlimited		
	–	Vijeo® Citect® Web Client	
Touchscreen	8.4 LCD TFT	12 LCD TFT	15 LCD TFT
Resolution	SVGA 800 x 600	SVGA 800 x 600	XGA 1024 x 768
Front panel ports	–	1 x USB	1 x USB
Processor	Celeron® M @ 600 MHz	Celeron M @ 1 GHz	Celeron M @ 600 MHz
RAM	512MB ▶ 1024MB	512MB ▶ 1024MB	512MB ▶ 1024MB
Storage	CF 1GB expandable to 4GB	CF 2GB expandable to 4GB	CF 2GB expandable to 4GB
Extension	–	1 x PCMCIA slot (for 1 type II card)	1 PCMCIA slot (for 1 type III card or 2 type I cards)
Ethernet ports	2 (10/100/1G + 10/100)	2 (10/100/1G + 10/100)	2 (10/100/1G + 10/100)
Ports I/O	4 x USB, 2 x RS232	4 x USB, 1 x RS232	4 x USB, 2 x RS232
Power supply	24 VDC	24 VDC	24 VDC
Dimension	230 x 177 x 65	313 x 239 x 60	395 x 294 x 65
References	XBTGTW450	XBTGTW652	XBTGTW750

1



XBT GT1105/1135



XBT GT210/2220/2330



XBT GT4230/4300



XBT GT5300



XBT GT6300



XBT GT7340

Monochrome touch screen terminals ⁽¹⁾

Type of screen	Number of ports	Application memory capacity	Compact Flash memory	Composite video input	Number of Ethernet ports	Reference	Weight kg
Optimum, 3.8" screen							
STN amber or red	1 COM1 1 USB	32 MB	No	No	- 1	XBT GT1105 XBT GT1135	
Optimum, 5.7" screen							
STN blue mode	1 COM1 1 COM2 1 USB	16 MB	No	No	-	XBT GT2110	1.000
Multifunction, 5.7" screen							
STN Black and white	1 COM1 1 COM2 1 USB	16 MB	Yes	No	- 1	XBT GT2120 XBT GT2130	1.000 1.000

Color touch screen terminals ⁽¹⁾

Type of screen	Number of ports	Application memory capacity	Compact Flash memory	Composite video input	Onboard Ethernet	Reference	Weight kg
Optimum, 3.8" screen							
TFT	1 COM1 1 USB	32 MB	No	No	1	XBT GT1335	1.000
Multifunction, 5.7" screen							
STN	1 COM1 1 COM2 1 USB	16 MB	Yes	No	-	XBT GT2220	1.000
TFT	1 COM1 1 COM2 1 USB	16 MB	Yes	No	1	XBT GT2330	1.000
Multifunction, 7.5" screen							
STN	1 COM1 1 COM2 1 USB	32 MB	Yes	No	1	XBT GT4230	1.800
TFT	1 COM1 1 COM2 1 USB	32 MB	Yes	No Yes	1 1	XBT GT4330 XBT GT4340	1.800 1.800
Multifunction, 10.4" screen							
STN	1 COM1 1 COM2 2 USB	32 MB	Yes	No	1	XBT GT5230	3.000
TFT	1 COM1 1 COM2 2 USB	32 MB	Yes	No Yes	1 1	XBT GT5330 XBT GT5340	2.500 2.500
Multifunction, 12.1" screen							
TFT	1 COM1 1 COM2 2 USB	32 MB	Yes	No Yes	1 1	XBT GT6330 XBT GT6340	3.000 3.000
Multifunction, 15" screen							
TFT	1 COM1 1 COM2 2 USB	32 MB	Yes	Yes	1	XBT GT7340	5.600

(1) Fixing kit (screw clamps), USB connectors locking device (except XBT GT 1100) and service instructions included with terminals. XBT GT setting-up documentation, in electronic format, is included with Vijeo Designer™ configuration software, see page 3/17.



XBT GK2120/2330



XBT GK5330



XBT GH2460



XBT ZGJBOX



XBT ZGHL●●

Keypad/touch screen terminals ⁽¹⁾

Type of screen	Number of ports	Application memory capacity	Compact Flash memory	Composite video input	Number of Ethernet ports	Reference	Weight kg
Multifunction, 5.7" screen							
STN Black and white	1 COM1 1 COM2 1 USB	32 MB	Yes	No	-	XBT GK2120	-
Multifunction, 5.7" screen							
TFT Color mode	1 COM1 1 COM2 1 USB	32 MB	Yes	No	1	XBT GK2330	-
Multifunction, 10.4" screen							
TFT Color mode	1 COM1 1 COM2 2 USB	32 MB	Yes	No	1	XBT GK5330	-

Hand-held touch screen terminal

Type of screen	Number of ports	Application memory capacity	Compact Flash memory	Composite video input	Number of Ethernet ports	Reference	Weight kg
Multifunction, 5.7" screen							
TFT Color mode	1 COM1 1 USB	32 MB	Yes	No	1	XBT GH2460 (2)	-

Connection components

Description	Usage	Length	Reference	Weight kg
Junction box for XBT GH	Specifically for terminal XBT GH, it enables: <ul style="list-style-type: none"> ■ 24 V supply to terminal XBT GH ■ connection of various safety inputs/outputs, ■ connection on multiprotocol serial link (9-pin SUB-D) or Ethernet TCP/IP (RJ45). Can be mounted on 35 mm DIN rail.	-	XBT ZGJBOX (2) (3)	-
Interface cable for XBT GH	Connecting terminal XBT GH to junction box XBT ZGJBOX	3 m	XBT ZGHL3 (2)	-
		10 m	XBT ZGHL10 (2)	-

(1) Fixing kit (spring clips), USB connectors locking device, customizable legend sheets and service instructions included with terminals.

(2) Terminal XBT GH is connected to junction box XBT ZGJBOX using cable XBT ZGHL●●, to be ordered separately (see table above). Description on page 1/44.

(3) A junction box is required at each XBT GH terminal connection point.

1



XBT GTW450

Open touch screen terminals (1)

Type of screen	Number of ports	Application memory capacity	Compact Flash memory	Video input	Number of Ethernet ports	Reference	Weight kg
Multifunction, 8.4" screen							
TFT	1 COM1 1 COM2 4 USB	256 MB RAM expandable to 1 GB, for system and application	1 GB expandable to 4 GB	No	2	XBT GTW450	3.500



XBT GTW652

Multifunction, 12" screen

TFT	1 COM1 1 COM2 5 USB	512 MB RAM expandable to 1 GB, for system and application	2 GB expandable to 4 GB	No	2	XBT GTW652	3.800
-----	---------------------------	--	-------------------------	----	---	-------------------	-------

Multifunction, 15" screen

TFT	1 COM1 1 COM2 5 USB	256 MB RAM expandable to 1 GB, for system and application	2 GB expandable to 4 GB	No	2	XBT GTW750	6.000
-----	---------------------------	--	-------------------------	----	---	-------------------	-------



XBT GTW750

(1) Fixing kit (screw clamps), USB connectors locking device and service instructions included with terminals. XBT setting-up documentation, in electronic format, is included with Vijeo Designer™ configuration software, see page 3/17.

Operator dialog terminals

Separate parts for Magelis® XBT GT/GK/GH/GTW Advanced Panels



XBT ZGM●●●

Separate parts				
Description	Size - software	Compatible with	Reference	Weight kg
Compact Flash memory cards	128 MB, blank	All terminals XBT except XBT GT1●●●/GT2110	XBT ZGM128	0.050
	256 MB, blank		XBT ZGM256	0.050
	512 MB, blank		MPC YN0 0CFE 00N	0.050
	1 GB, blank		MPC YN0 0CF1 00N	–
	2 GB, blank		MPC YN0 0CF2 00N	–
	4 GB, blank		MPC YN0 0CF4 00N	–
	1 GB, Vijeo Designer™ RT Edition software in 6 languages pre-installed	XBT GTW 450	MPC YN1 1CF1 10H	–
	2 GB, with following software pre-installed: Windows XP® Embedded SP2 in 9 languages (English, French, Italian, German, Portuguese, Russian, Spanish, Swedish, Chinese), .NET RT®, Vijeo® Citect® Web Client and Office Readers	XBT GTW 750	MPC YN52 CF2 20T	–
	2 GB, with following software pre-installed: Windows XP Embedded SP2 in 9 languages (English, French, Italian, German, Portuguese, Russian, Spanish, Swedish, Chinese), .NET RT, Vijeo Designer Run Time and Office Readers	XBT GTW 750	MPC YN52 CF2 20H	–
	Maintenance kits	Includes panel mounting fixings and seals	8.4" models MPC ST1 1N●J 00T	MPC YK1 0MNT KIT
12" models MPC ST2 1N●J20●			MPC YK2 0MNT KIT	–
15" models MPC ST5 2NDJ 10			MPC YK5 0MNT KIT	–
Protective sheets (5 peel-off sheets)	–	XBT GT1105/GT1135/GT1335	XBT ZG60	–
	–	XBT GT1100/GT1130	XBT ZG61	–
	–	XBT GT21●0/GT2220/GT2330	XBT ZG62	0.200
	–	XBT GT4230/GT43●0	XBT ZG64	0.200
	–	XBT GT53●0	XBT ZG65	0.200
	–	XBT GT5230/GT63●0	XBT ZG66	0.200
	–	XBT GK 2●●0/GH2460	XBT ZG68	–
	–	XBT GK 5330	XBT ZG69	–
	–	XBT GT7340/XBT GTW750	MPC YK5 0SPS KIT	0.200
	–	XBT GTW450	MPC YK1 0SPS KIT	–
–	XBT GTW652	MPC YK2 0SPS KIT	–	
Spring fixing clips Sold in lots of 12	–	Terminals XBT GT (number of spring clips depending on terminal)	XBT Z3002	–
Wall mounting kit	Fixing components for mounting terminal XBT GH on a wall	Terminal XBT GH	XBT ZGWMKT	–
Neck strap	For use with hand-held terminal XBT GH	Terminal XBT GH	XBT ZGNSTP	–
Emergency stop button protection	For avoiding accidental operation of the Emergency stop button	Terminal XBT GH	XBT ZGESGD	–

Operator dialog terminals

Spare parts for Magelis®

XBT GT/GK/GH/GTW Advanced Panels

1



XBT ZGCO



XBT ZGUSB

Separate components (continued)

Description	Details	Length	Reference	Weight kg
Mechanical adaptors for substituting previous version Magelis® range terminals	From XBT F032●10 to XBT GT2●●0	–	XBT ZGCO1	–
	From XBT G2110 to XBT GT2●●0	–	XBT ZGCO2	–
	From XBT F034●●● to XBT GT53●0	–	XBT ZGCO3	–
	From XBT G5330 to XBT GT5330	–	XBT ZGCO4	–
Remote USB port for terminals: XBT GT2●●0 to GT7340 GT1●●5, GK●●●, GTW●●●	Enables remote location of USB port on rear of terminal XBT, either on panel or enclosure door (Ø 21 mm fixing device)	1 m	XBT ZGUSB	–
Adaptor for Compact Flash cards	Enables a PC with a PCMCIA card slot to be adapted to take a Compact Flash card	–	XBT ZGADT	0.050

Spare parts

Description	For use with	Reference	Weight kg
Seals	XBT GH (for junction box)	XBT ZG5H	–
	XBT GT1100/GT1130/GT1105/GT1135/GT1335	XBT ZG51	0.030
	XBT GT21●0/GT2220/GT2330	XBT ZG52	0.030
	XBT GT4230/GT43●0	XBT ZG54	0.030
	XBT GT53●0	XBT ZG55	0.030
	XBT GT5230/GT63●0	XBT ZG56	0.030
	XBT GT7340	XBT ZG57	0.030
	XBT GK2●●0	XBT ZG58	–
	XBT GK5330	XBT ZG59	–
Back-lighting lamps	XBT GT5230	XBT ZG43	0.100
	XBT GT53●0	XBT ZG45	0.200
	XBT GT53●0 PV ≥ 3	XBT ZG45B	0.200
	XBT GT63●0	XBT ZG46	0.200
	XBT GT7340	XBT ZG47	0.200
USB fastening Sold in lots of 5	XBT GT1●●0/GT2●●0/GT4●●0	XBT ZGCLP1	–
	XBT GT1●●5/GT5●●0/GT6●●0/GT7●●0	XBT ZGCLP2	–
	XBT GK	XBT ZGCLP3	–
Fixing kit	4 clamps and screws (max. tightening torque: 0.5 Nm). Included with all XBT GT terminals	XBT ZG FIX	0.100
Extension connector protector	XBT GT/GK except XBT GT1●●●	XBT ZGCNC	0.030
Power supply connector Sold in lots of 5	XBT GT1●●●/GT2●●● XBT GT4●●● XBT GK2●●●	XBT ZGPWS1	0.030
	XBT GT5●●●/6●●●/7●●● XBT GK5●●● XBT GTW●●●	XBT ZGPWS2	–
Auxiliary connector	XBT GT4●●●/5●●●/6●●●/7●●●, XBT GK5●●●	XBT ZGAUX	–
Sheets of customizable labels Sold in lots of 10	XBT GK2●●0	XBL YGK2	0.030
	XBT GK5●●●	XBL YGK5	–
	XBT GH	XBT YGH2	–
Stylus Sold in lots of 5	XBT GH	XBT ZGPEN	–
Emergency stop button protector	XBT GH	XBT ZGESD	–
Hand strap	XBT GH	XBT ZGHSTP	–

Application transfer cables - terminal to PC

Type of terminal (terminal side connector)	Connector (PC side)	Type	Length	Reference (1)	Weight kg
XBT GT2●●0...GT7340, XBT GT1●●5, XBT GK, XBT GH XBT GTW	USB	TTL	2 m	XBT ZG935	0.290

Printer connection cables

Type of printer	Connector (printer side)	Type	Length	Reference	Weight kg
Serial printer (2) for terminals XBT GT/GK/GTW (except XBT GT1●●●)	25-pin female SUB-D	RS 232C (COM1)	2.5 m	XBT Z915	0.200

Adaptors and isolation units for terminals XBT

These 3 adaptors are used with the connection cables to suit the application. For example, using cable XBT Z968 with “+ (2)”, i.e. adaptor XBT ZG909, enables connection of a Twido® controller (via its terminal port) to an XBT GT2●●0 terminal (via its COM1 port).

Description	Type of connector (automation product side)	Physical link (XBT GT terminal side)	Length	Reference	Weight kg
Adaptor for XBT GT1●●● (COM1 port) XBT GT2●●0...7340/ XBT GK (COM2 port)	25-pin SUB-D connector	RJ45 connector	0.2 m	XBT ZG939	–
Adaptors for XBT GT2●●0...7340/XBT GK (COM1 port) XBT GTW (COM1 and COM2 ports)	25-pin SUB-D connector	9-pin SUB-D connector, RS 485	0.2 m	XBT ZG909	–
		9-pin SUB-D connector, RS 232C	0.2 m	XBT ZG919	–



XBT ZGI485

Description	Usage	Link to be isolated	Reference	Weight kg
Serial link isolation units for XBT	- Connection to serial port of terminal XBT	RS 232C/RS 485	XBT ZGI232	–
GT2●●0...7340/XBT GK	- Isolated link on 9-pin SUB-D connector (3)	(COM1)		
	- Unit power supply via the USB port of the terminal. Incorporates a USB hub	RS 485 (COM2)	XBT ZGI485	–

(1) Cable included (according to model) with Vijeo Designer software packages, see page 3/17.

(2) Parallel printer, see page 1/31.

(3) Male connector for XBT ZGI232, female connector for XBT ZGI485.

Operator dialog terminals

Connection accessories for Magelis® XBT GT/GK/GH/GTW Advanced Panels

1

Cables for connecting XBT GT to other Schneider Electric products							
Automation product type	Type of connector (automation product side)	Protocol	Type of XBT terminal, physical link	On XBT port	Length	Reference	Weight kg
Twido® , Nano™ , Modicon® TSX Micro™ , Modicon® Premium™	Terminal port, 8-pin female (V1/V2), mini-DIN	Uni-TE™ (V1/V2), Modbus®	XBT GT1●●●, RS 485	COM1	2.5 m	XBT Z9780	0.180
			XBT GT2●●0...7340, XBT GK, RS 485	COM2	10 m	XBT Z9782	–
			XBT GT2●●0...7340, XBT GK, RS 485	COM1	2.5 m	XBT Z968 + (2)	0.180
			XBT GT2●●0...7340, XBT GK, RS 485	COM1	5 m	XBT Z9681 + (2)	0.340
			XBT GT2●●0...7340, XBT GK, RS 485 XBT GH (Junction box)	COM1	2.5 m	XBT Z9018	0.170
			XBT GTW●●, RS 232 XBT GH (Junction box)	COM1	2.5 m	TSX PCX 1031	–
Modicon® M340™ Modicon® M238™	RJ45	Modbus	XBT GT1●●●, RS 485	COM1	2.5 m	XBT Z9980	0.230
			XBT GT2●●0...7340, XBT GK, RS 485	COM2	10 m	XBT Z9982	–
			XBT GT2●●0...7340, XBT GK, RS 485	COM1	1.8 m	XBT Z938 + (2)	0.230
			XBT GT2●●0...7340, XBT GK, RS 485 XBT GH (Junction box)	COM1	2.5 m	XBT Z9008	–
			USB	Terminal port	XBT GT (4) XBT GK/GTW	USB	1.8 m
				4.5 m	BMX XCA USB H045	–	
Modicon Premium with TSX SCY 2160●	25-pin female SUB-D	Uni-TE (V1/V2)	XBT GT1●●●, RS 485	COM1	2.5 m	XBT Z918 + (1)	0.230
			XBT GT2●●0...7340, XBT GK, RS 485 XBT GH (Junction box)	COM1	2.5 m	XBT Z918 + (2)	0.230
Modicon® Quantum™	9-pin female SUB-D	Modbus	XBT GT1●●●, RS 232C	COM1	2.5 m	XBT Z9710 + (1)	0.210
			XBT GT2●●0...7340, XBT GK/GTW, RS 232C XBT GH (Junction box)	COM1	2.5 m	XBT Z9710 + (3)	0.210
					3.7 m	990 NAA 263 20	0.290
Advantys™ STB	HE13 (NIM, network interface module)	Modbus	XBT GT1●●●, RS 232C	COM1	2.5 m	XBT Z988 + (1)	0.220
						XBT Z9715	–
			XBT GT2●●0...7340, XBT GK/GTW, RS 232C XBT GH (Junction box)	COM1	2 m	STB XCA 4002	0.210
				2.5 m	XBT Z988 + (3)	0.220	
Modicon® Momentum™ M1	RJ45 (port 1 of Momentum M1)	Modbus	XBT GT1●●●, RS 232C	COM1	2.5 m	XBT Z9711 + (1)	0.210
			XBT GT2●●0...7340, XBT GK, XBT GTW RS 232C XBT GH (Junction box)	COM1	2.5 m	XBT Z9711 + (3)	0.210
TeSys® U, T starters Altivar® 31/61/71 speed drives Altistart® 48 starters Lexium® 05 Preventa™ XPSMC	RJ45	Modbus	XBT GT1●●●, RS 485	COM1	3 m	VW3 A8 306 R30	0.060
					2.5 m	XBT Z9980	–
			XBT GT2●●0...7340, XBT GK, RS 485	COM2	10 m	XBT Z9982	–
			XBT GT2●●0...7340, XBT GK, RS 485 XBT GH (Junction box)	COM1	2.5 m	XBT Z9008	–

(1) Adaptor **XBT ZG939** to be used with cables with " + (1) " after the reference, see page 1/55.
 (2) Adaptor **XBT ZG909** to be used with cables with " + (2) " after the reference, see page 1/55.
 (3) Adaptor **XBT ZG919** to be used with cables with " + (3) " after the reference, see page 1/55.
 (4) Except XBT GT1●●0.



TSX PCX 1031

Cables and adaptors for connecting XBT terminals to third party PLCs

Mitsubishi (Melsec®) PLCs

Description Driver used	Type of XBT terminal	Type of connectors (fitted to cable, excluding adaptor)	Physical link (COM1)	Length	Reference	Weight kg
Connection cable, A CPU (SIO)	GT2●●0...7340/ GK/ GH (Junction box)	9-pin SUB-D/25-pin SUB-D	RS 422	5 m	XBT ZG9773	–
Connection cable, Q Link (SIO)	GT2●●0...7340 /GK/GTW/ GH (Junction box)	9-pin SUB-D/9-pin SUB-D	RS 232C	5 m	XBT ZG9772	–
Connection cable, Q CPU (SIO)	GT2●●0...7340 /GK/GTW/ GH (Junction box)	9-pin SUB-D/mini-DIN	RS 232C	5 m	XBT ZG9774	–
Connection cable, A Link (SIO)	GT2●●0...7340 /GK/GTW/ GH (Junction box)	9-pin SUB-D/25-pin SUB-D	RS 232C	5 m	XBT ZG9731	–
Connection cable, FX (CPU)	GT2●●0...7340 /GK/ GH (Junction box)	9-pin SUB-D/mini-DIN	RS 422	5 m	XBT ZG9775	–
	GT1●●●	25-pin SUB-D/mini-DIN	RS 422	5 m	XBT Z980 + (1)	–
Cable for 2 port adaptor, FX (CPU), A CPU (SIO) QnA CPU (SIO)	GT2●●0...7340 /GK/ GH (Junction box)	9-pin SUB-D/free wires other end	RS 422	5 m	XBT ZG9778 + (4)	–
Adaptor unit FX (CPU), A CPU (SIO) QnA CPU (SIO)	GT2●●0...7340 /GK/ GH (Junction box)	2 port unit Screw terminals/2 x 9-pin SUB-D	RS 422	–	XBT ZG979	–



XBT ZG9772



XBT ZG9731

Omron (Sysmac®) PLCs

Description Driver used	Type of XBT terminal	Type of connectors (fitted to cable, excluding adaptor)	Physical link (COM1)	Length	Reference	Weight kg
Connection cables, Link (SIO)	GT1●●●	25-pin SUB-D/9-pin SUB-D	RS 232C	2.5 m	XBT Z9740 + (1) XBT Z9743	0.210 –
	GT2●●0...7340 /GK/GTW/ GH (Junction box)	9-pin SUB-D/9-pin SUB-D	RS 232C	5 m	XBT ZG9740	–
		9-pin SUB-D/25-pin SUB-D	RS 232C	5 m	XBT ZG9731	–
Connection cables, FINS (SIO)	GT1●●●	25-pin SUB-D/9-pin SUB-D	RS 232C	2.5 m	XBT Z9740 + (1) XBT Z9743	0.210 –
	GT2●●0...7340 /GK/GTW/ GH (Junction box)	9-pin SUB-D/9-pin SUB-D	RS 232C	5 m	XBT ZG9740	–

(1) Adaptor **XBT ZG939** to be used with cables with " + (1) " after the reference, see page 1/55.

(4) Cable **XBT ZG9778** to be used with 9-pin female/female SUB-D adaptor **XBT ZGCOM1**.

Operator dialog terminals

Connection accessories for Magelis® XBT GT/GK/GH/GTW Advanced Panels

1



XBT ZG9731

Cables and adaptors for connecting XBT GT terminals to third party PLCs (continued)

Rockwell Automation (Allen-Bradley) PLCs

Description Driver used	Type of XBT terminal	Type of connectors (fitted to cable, excluding adaptor)	Physical link (COM1)	Length	Reference	Weight kg
Connection cables, DF1 Full Duplex	GT1●●●	25-pin SUB-D/9-pin SUB-D	RS 232C	2.5 m	XBT Z9730 + (1)	0.210
					XBT Z9733	–
		25-pin SUB-D/8-pin mini-DIN	RS 232C	2.5 m	XBT Z9731 + (1)	0.210
	GT2●●0...7340 /GK/GTW/ GH (Junction box)	9-pin SUB-D/25-pin SUB-D	RS 232C	5 m	XBT ZG 9731	–
Connection cables, DH485	GT1●●●	25-pin SUB-D/9-pin SUB-D	RS 232C	2.5 m	XBT Z9734	–
			25-pin SUB-D/8-pin mini-DIN	RS 485	5 m	XBT Z9732 + (1)
		GT2●●0...7340 /GK/ GH (Junction box)	25-pin SUB-D/8-pin mini-DIN	RS 485	5 m	XBT Z9732 + (2)

Siemens (Simatic®) PLCs

Description Driver used	Type of XBT terminal	Type of connectors (fitted to cable, excluding adaptor)	Physical link	Length	Reference	Weight kg
Connection cable, PPI, S7 200	GT1●●●	RJ45/9-pin SUB-D	RS 485 (COM1)	2.5 m	XBT ZG9721	–
		GT2●●0...7340 /GK	RJ45/9-pin SUB-D	RS 485 (COM2)		
Connection cables, MPI port, S7 300/400	GT2●●0...7340 /GK/GTW/ GH (Junction box)	9-pin SUB-D/9-pin SUB-D	RS 232C (COM1)	3 m	XBT ZG9292	–
		GT2●●0...7340 /GK	RJ45/free wires other end	RS 485 (4) (COM2)	3 m	VW3 A8 306 D30
			RJ45/9-pin SUB-D	RS 485 (4) (COM2)	2.5 m	XBT ZG9721

Customizable cables

Description Driver used	Type of XBT terminal	Type of connectors (fitted to cable, excluding adaptor)	Physical link	Length	Reference	Weight kg
Universal cable, RS 422	GT2●●0...7340 /GK/ GH (Junction box)	9-pin SUB-D/free wires other end	RS 422 (COM1)	2.5 m	XBT ZG9722	0.210
Universal adaptor, RS 422/485	GT2●●0...7340 /GK/ GH (Junction block)	9-pin SUB-D/Screw terminal	RS 422 (COM1)	–	XBT ZG949 + (5)	–
		9-pin SUB-D/Screw terminal	RS 485 (COM2)	–	XBT ZG949 + (6)	–

- (1) Adaptor **XBT ZG939** to be used with cables with " + (1) " after the reference, see page 1/55.
(2) Adaptor **XBT ZG909** to be used with cables with " + (2) " after the reference, see page 1/55.
(4) Non isolated RS 485 serial link, 12 Mbps (187.5 kbps with **XBT GT11●0/2110**).
(5) Cable to be created by user and used in conjunction with 9-pin female/female SUB-D adaptor **XBT ZGCOM1**.
(6) Cable to be created by user and used in conjunction with isolation unit **XBT ZGI485** and 9-pin male/female SUB-D adaptor **XBT ZGCOM2**.

Operator dialog terminals

Connection accessories for Magelis® XBT GT/GK/GH/GTW Advanced Panels



TSX SCA 62



TSX PACC 01



TSX SCA 64



LU9 GC3



VW3 A8 306 TF10



TWDXCAISO

Connecting XBT terminals via serial links and Ethernet network

Type of bus/network	Tap-off units	Connector (tap-off unit side)	Type of XBT terminal	Length	Reference	Weight kg
Uni-Telway™ serial link	Subscriber socket socket TSX SCA 62	15-pin female SUB-D	GT1●●● (COM1)	3 m	VW3 A8 306	0.150
			GT2●●0...7340/GK (COM2)			
			GT2●●0...7340/GK (COM1) GH (Junction box)	1.8 m	XBT Z908 + (2)	0.240
	Connection box TSX P ACC01	8-pin female mini-DIN	GT1●●● (COM1)	2.5 m	XBT Z9780	0.180
			GT2●●0...7340/GK (COM2)			
			GT2●●0...7340/GK (COM1) GH (Junction box)	2.5 m	XBT Z9018	–
Modbus® serial link	Subscriber socket socket TSX SCA 64	15-pin female SUB-D	GT1●●● (COM1)	3 m	VW3 A8 306	0.150
			GT2●●0...7340/GK (COM2)			
			GT2●●0...7340/GK (COM1) GH (Junction box)	1.8 m	XBT Z908 + (2)	0.240
	8 port Modbus splitter box LU9 GC3	RJ45	GT1●●● (COM1)	3 m	VW3 A8 306R30	0.060
			GT2●●0...7340/GK (COM2)	2.5 m	XBT Z9980	–
			GT2●●0...7340/GK (COM1) GH (Junction box)	2.5 m	XBT Z9008	–
T-connector	With integrated cable, RJ45 fitted	GT1●●● (COM1)	1 m	VW3 A8 306 TF10	–	
		GT2●●0...7340/GK (COM2)				
Ethernet TCP/IP network	Hubs 499 NEH/NOH Switches 499 NES, 499 NMS, 499 NSS and 499 NOS	RJ45	GT●●30/●●40	2 m	490 NTW 000 02	–
			GK●●30	5 m	490 NTW 000 05	–
			GTW●●●	12 m	490 NTW 000 12	–
			GH (Junction box)	40 m	490 NTW 000 40	–
				80 m	490 NTW 000 80	–

Connecting XBT terminals to fieldbus

Type of bus/network	Connection components	Type of XBT terminal	Reference	Weight kg
Fipway®, Fipio®	USB gateway	XBT GT/GK (3)	TSXCUSBFIP	–
Modbus Plus™	USB gateway	XBT GT/GK (3)	XBTZGUMP	–
		XBT GTW	TSXCUSBMBP	–
Profibus DP	Card on Bus expansion	XBT GT/GK (3)	XBTZGPDP	–
DeviceNet™	Card on Bus expansion	XBT GT/GK (3)	XBTZGDVN	–

Modular regulated switch mode power supplies ABL 7RM (4)

Input voltage/ Output voltage	Use with XBT	Nominal power	Nominal current	Reference	Weight kg
100...240/24 V single-phase wide range mains supply, 47...63 Hz	GT1100...6340 /GK/GH	30 W	1.3 A	ABL 7RM2401	0.182
	GT7340/GTW	60 W	2.5 A	ABL 7RM24025	0.255

(2) Adaptor **XBT ZG909** to be used with cables with " + (2) " after the reference, see page 1/55.

(3) Except **XBT GT1●●●**.

(4) Dimensions: H x W x D = 90 x 72 x 59 mm. For further information, please refer to our "Power supplies, splitter boxes and interfaces" catalog.



ABL 7RM240●

Operator dialog terminals

Magelis® Advanced Panels

Wiring system

1

XBT GT11●5 terminals and Schneider Electric products

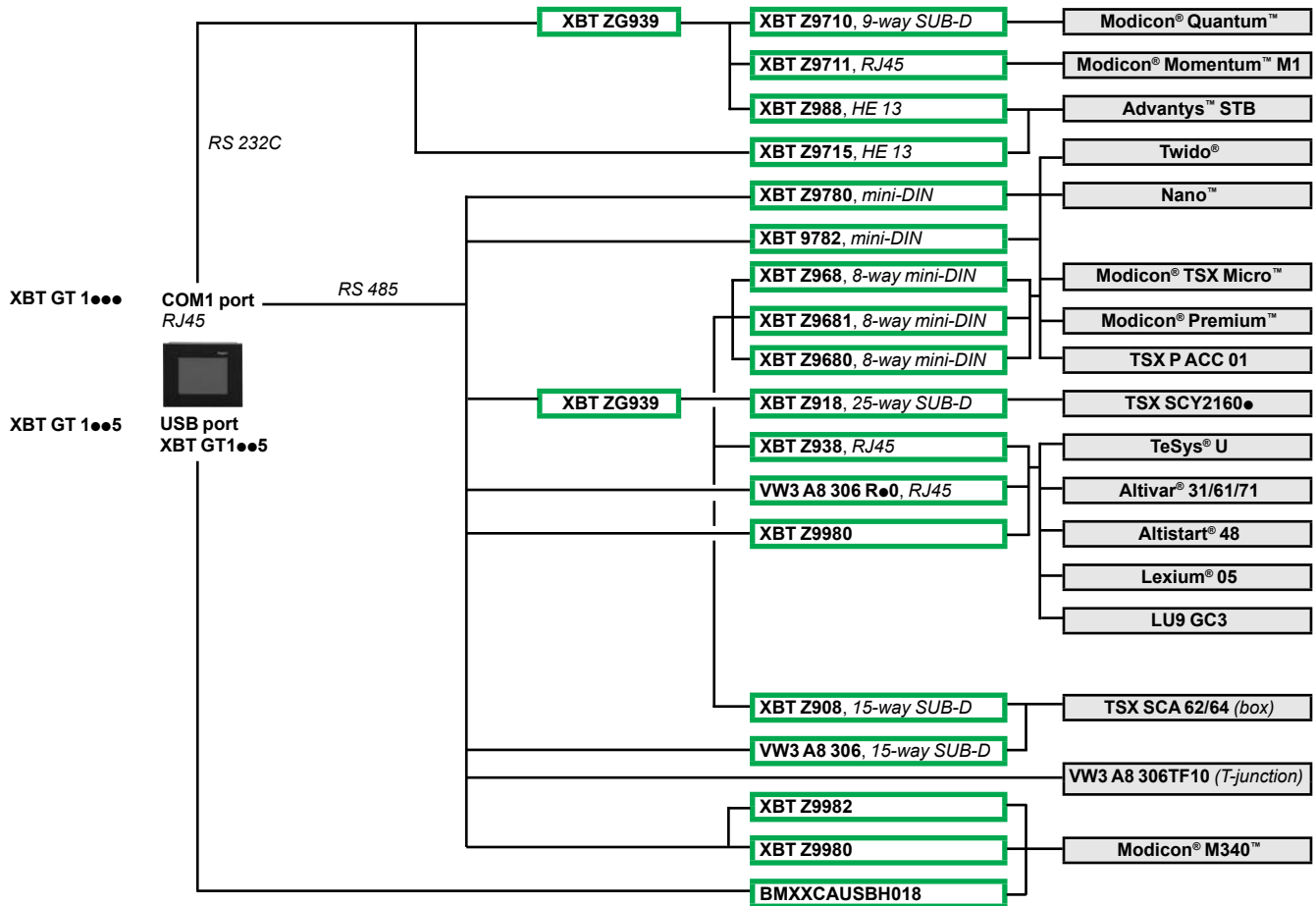

XBT GT2●●0/GT7340/GK●●●● terminals and Schneider Electric products

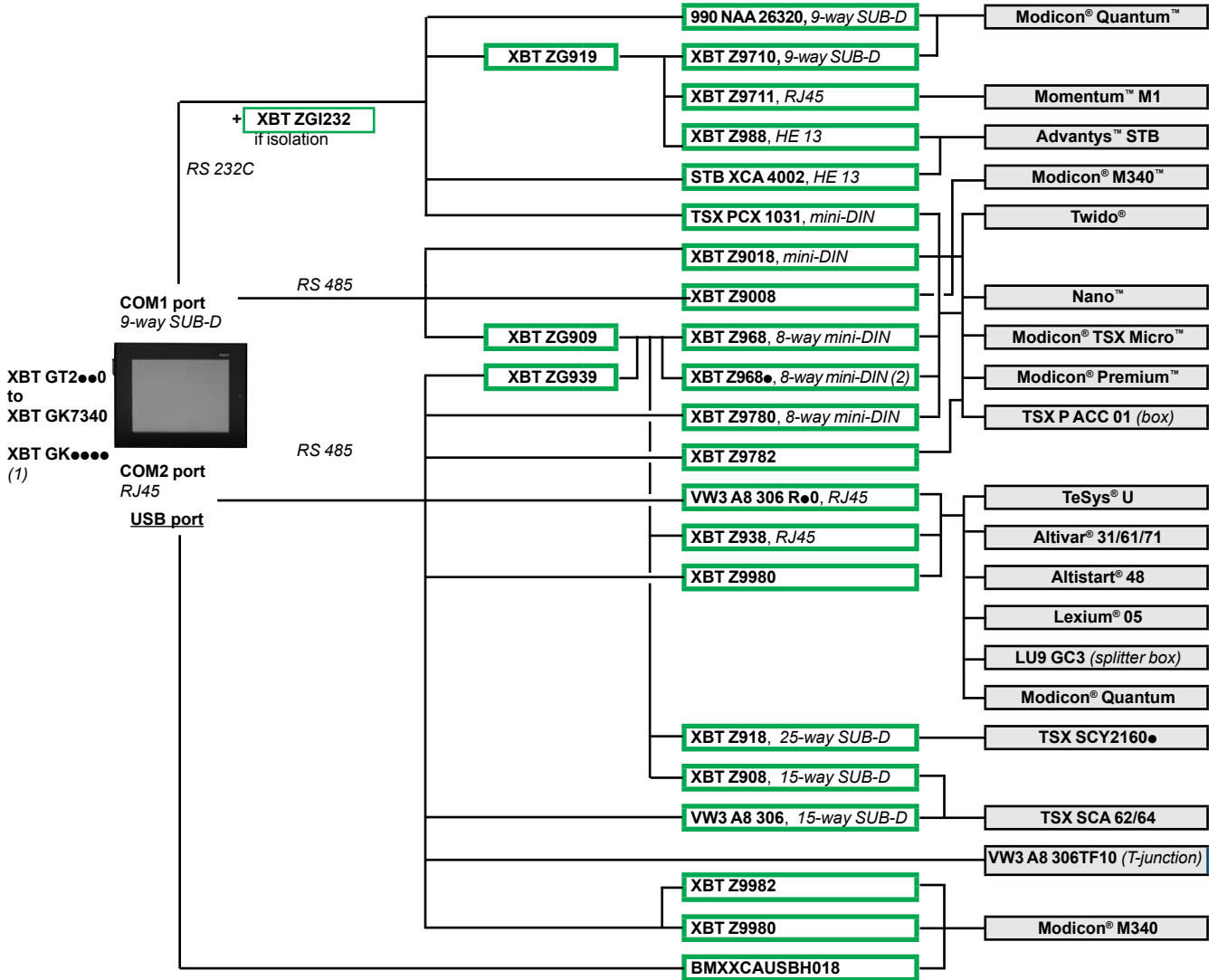

(1) XBT GK USB port only
 (2) ● defines the length:
 - 0, length 2.5 m (angled version)
 - 1, length 5 m
 - 6, length 16 m
 - 7, length 20 m
 - 8, length 25 m

Operator dialog terminals

Magelis® Advanced Panels

Wiring system

1

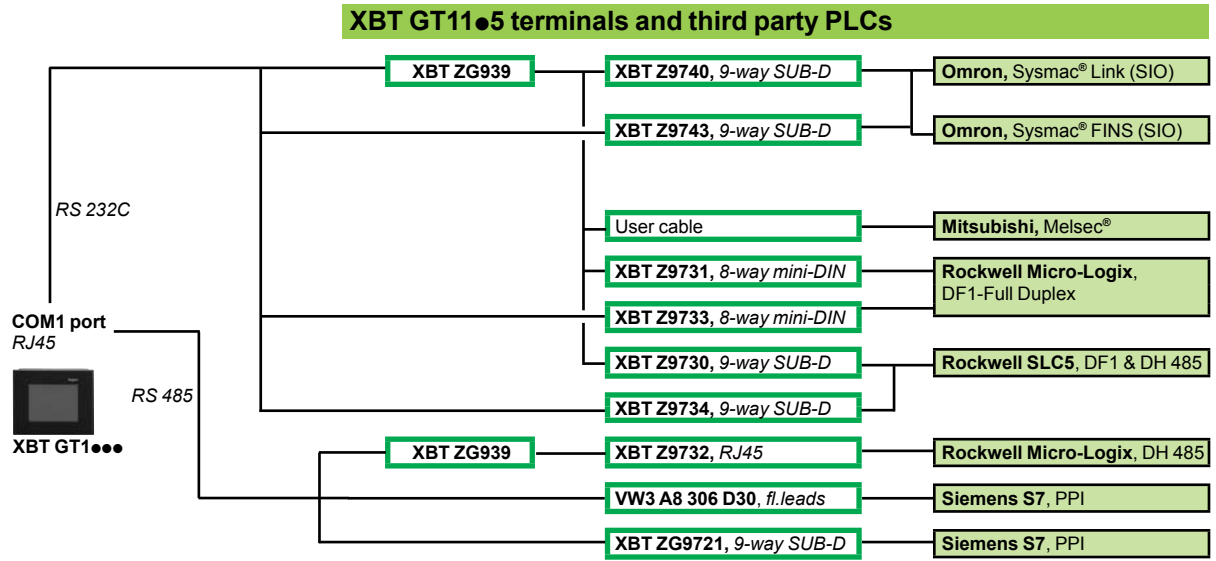

XBT GT2●●0/GT7340/GK●●●● terminals and third party PLCs

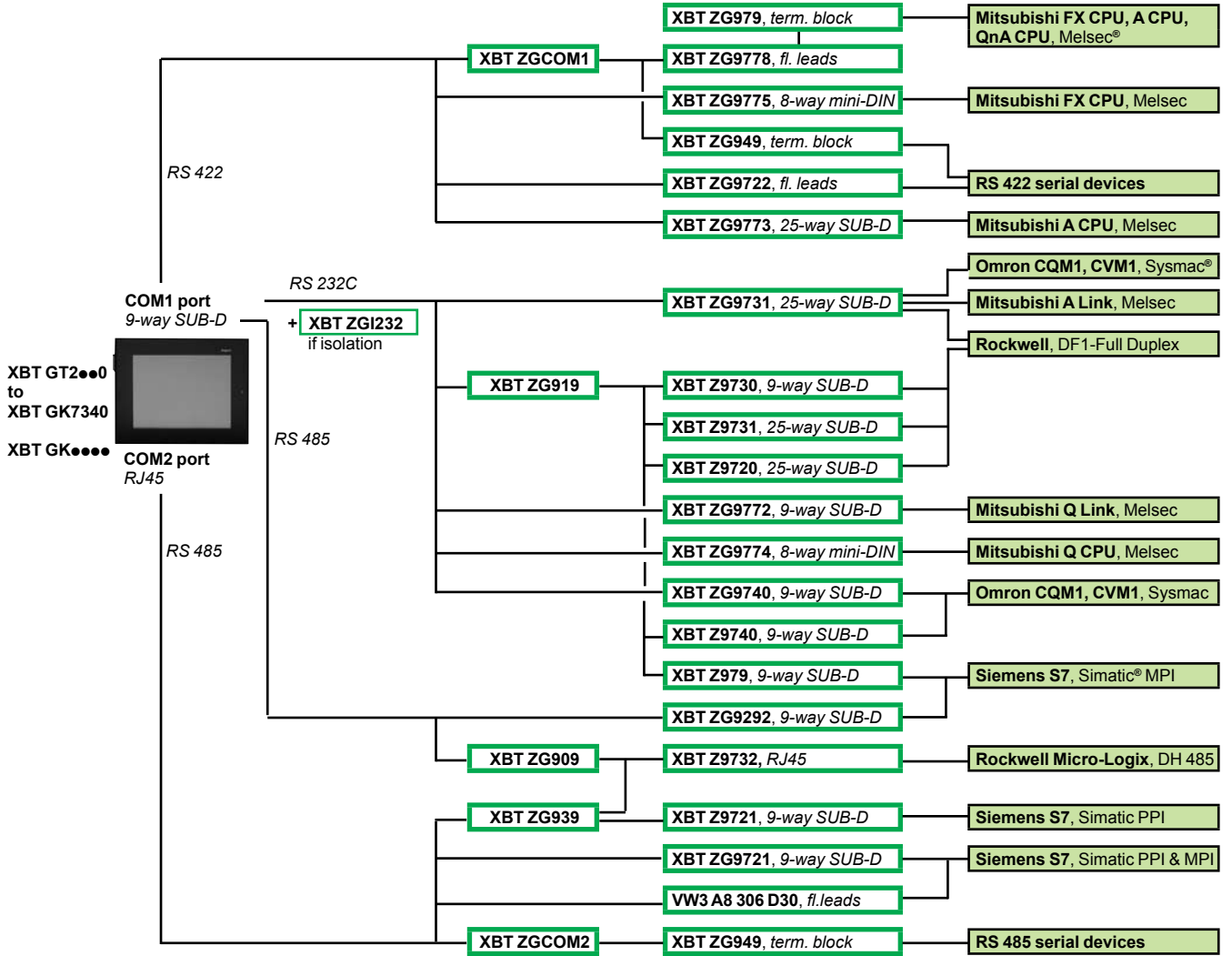

Application transfer from XBT GT terminals to PC

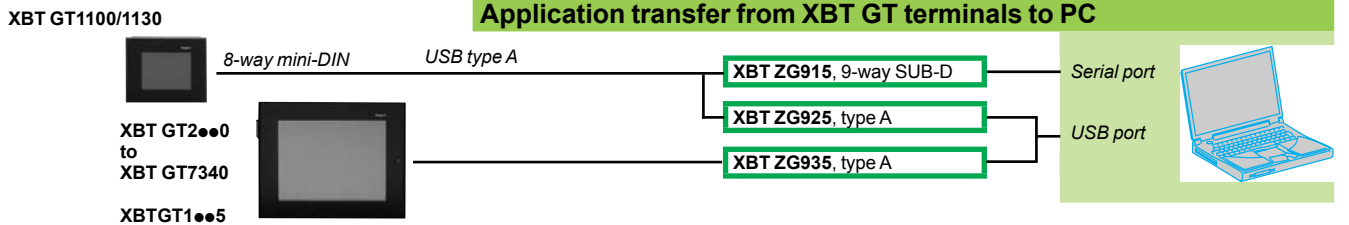

Operator dialog terminals

Magelis® Advanced Panels

Equivalent product tables for XBT F, XBT FC to XBT GT and XBT F to XBT GK

1

Equivalent product table - Magelis® XBT F 5" color touch screen terminals to XBT GT terminals

Old range XBT F	New range XBT GT	Mechanical adaptor
XBT F032110	XBT GT2220	XBT ZGCO1
XBT F032310	XBT GT2220	XBT ZGCO1

Equivalent product table - Magelis® XBT F 10" color touch screen terminals to XBT GT terminals

Old range XBT F	New range XBT GT	Mechanical adaptor
XBT F034310	XBT GT5330	XBT ZGCO3
XBT F034110	XBT GT5330	XBT ZGCO3
XBT F034510	XBT GT5330	XBT ZGCO3
XBT F034610	XBT GT5330	XBT ZGCO3

Equivalent product table - Magelis® XBT FC 5" terminals to XBT GT terminals

Old range XBT FC	New range XBT GT	Mechanical adaptor
XBT FC022310	XBT GT2220	XBT ZGCO1

Equivalent product table - Magelis® XBT FC 10" terminals to XBT GT terminals

Old range XBT FC	New range XBT GT	Mechanical adaptor
XBT FC044310	XBT GT5330	XBT ZGCO3
XBT FC044510	XBT GT5330	XBT ZGCO3
XBT FC044610	XBT GT5330	XBT ZGCO3
XBT FC064310	XBT GT5330	XBT ZGCO3
XBT FC064510	XBT GT5330	XBT ZGCO3
XBT FC064610	XBT GT5330	XBT ZGCO3
XBT FC084310	XBT GT5330	XBT ZGCO3
XBT FC084510	XBT GT5330	XBT ZGCO3
XBT FC084610	XBT GT5330	XBT ZGCO3

Equivalent product table - Magelis® XBT F 5" and 10" color keypad terminals to XBT GK terminals

Old range XBT F	New range XBT GK	Mechanical adaptor
XBT F011110	XBT GK2330/GK2120	–
XBT F011310	XBT GK2330/GK2120	–
XBT F023110	XBT GK5330	–
XBT F023310	XBT GK5330	–
XBT F024110	XBT GK5330	–
XBT F024510	XBT GK5330	–
XBT F024610	XBT GK5330	–

The dimensions of the products are identical.

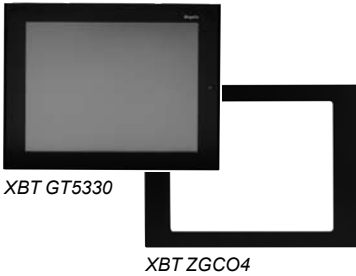

Equivalent product table - Magelis® XBT G terminals to XBT GT terminals

Old range XBT G	New range XBT GT <i>Requires Vijeo Designer ≥ V4.3</i>	Mechanical adaptor (1)
XBT G2110	XBT GT2110	XBT ZGCO2
XBT G2120	XBT GT2120	–
XBT G2130	XBT GT2130	–
XBT G2220	XBT GT2220	–
XBT G2330	XBT GT2330	–
XBT G4320	XBT GT4330	–
XBT G4330	XBT GT4330	–
XBT G5230	XBT GT5230	–
XBT G5330	XBT GT5330	XBT ZGCO4
XBT G6330	XBT GT6330	–
XBT ZG MBP	XBT ZG UMP	Modbus Plus™ network connection

Equivalent product table - Connection cables to Schneider Electric products

Summary		
Old range XBT G	New range XBT GT2●●0...GT6330	
Type of link	Type of link	Cable + adaptor reference
COM1, RS 232C, SUB-D 25	COM1, RS 232C, SUB-D 9	Existing cable + XBT ZG919
	COM2, RS 485, RJ45	Existing cable + RS 485/RS 232C converter + XBT ZG939
COM1, RS 485, SUB-D 25	COM1, RS 485, SUB-D 9	Existing cable + XBT ZG909
	COM2, RS 485, RJ45	Existing cable + XBT ZG939
COM2, RS 232C, SUB-D 9	COM1, RS 232C, SUB-D 9	Existing cable
	COM2, RS 485, RJ45	Existing cable + RS 485/RS 232C converter + XBT ZG939

Equivalent product table - Connection cables

Old range XBT G2●●0...G6330				New range XBT GT2●●0...GT6330			
Type of terminal	Type of link	Length	Reference	Type of terminal	Type of link	Length	New reference Cable + adaptor
Twido®, Modicon® TSX Micro™, Modicon® Premium™, 8-way female mini-DIN terminal port, Uni-TE (V1/V2), Modbus® protocol							
XBT G	COM1, RS 485	2.5 m	XBT Z968	XBT GT	COM1, RS 485	2.5 m	XBT Z968 + XBT ZG909
	SUB-D 25	5 m	XBT Z9681		SUB-D 9	5 m	XBT Z9681 + XBT ZG909
XBT G	COM2, RS 232C SUB-D 9	2.5 m	TSX PCX 1031	XBT GT	COM1, RS 232C SUB-D 9	2.5 m	TSX PCX 1031
				XBT GT	COM2, RS 485 RJ45	2.5 m	XBT Z9780
Modicon Premium with TSX SCY 2160●, 25-pin female SUB-D connector, Uni-TE (V1/V2) protocol							
XBT G	COM1, RS 485 SUB-D 25	2.5 m	XBT Z918	XBT GT	COM1, RS 485 SUB-D 9	2.5 m	XBT Z918 + XBT ZG909
Modicon® Quantum™, 9-pin male SUB-D connector, Modbus® protocol							
XBT G	COM1, RS 232C SUB-D 25	2.5 m	XBT Z9710	XBT GT	COM1, RS 232C SUB-D 9	2.5 m	XBT Z9710 + XBT ZG919
							3.7 m
Advantys™ STB, HE13 connector (NIM), Modbus protocol							
XBT G	COM2, RS 232C SUB-D 9	2 m	STB XCA 4002	XBT GT	COM1, RS 232C SUB-D 9	2 m	STB XCA 4002
Modicon® Momentum™ M1, RJ45 connector (port 1), Modbus protocol							
XBT G	COM1, RS 232C SUB-D 25	2.5 m	XBT Z9711	XBT GT	COM1, RS 232C SUB-D 9	2.5 m	XBT Z9711 + XBT ZG919
TeSys® U starters, Altivar® 31/61/71 drives, Altistart® 48 starters, RJ45 connector, Modbus protocol							
XBT G	COM1, RS 485 SUB-D 25	2.5 m	XBT Z938	XBT GT	COM1, RS 485 SUB-D 9	2.5 m	XBT Z938 + XBT Z909
				XBT GT	COM2, RS 485 RJ45	3 m	VW3 A8 306 R30

(1) Mechanical adaptor for mounting terminal XBT GT when replacing an XBT G terminal.

1

Equivalent product table - Application transfer cables to PC and printer cables							
Old range XBT G2●●0...G6330				New range XBT GT2●●0...GT6330			
Type of terminal	Type of link	Length	Reference	Type of terminal	Type of link	Length	New reference
Application transfer cables to PC							
XBT G	Mini-DIN/SUB-D 9	2 m	XBT ZG915	XBT GT	USB/USB	2 m	XBT ZG935
	Mini-DIN/USB	2 m	XBT ZG925				
Serial printer cable							
XBT G	COM2, RS 232C	2.5 m	XBT Z915	XBT GT	COM1, RS 232C	2.5 m	XBT Z915
Parallel printer cable							
XBT G	Centronics type, Epson ESC/P		XBT ZG946	XBT GT	USB, Hewlett Packard model	Connection via USB/PIO converter (not supplied by Schneider Electric)	
					Centronics type, Epson ESC/P	2 m	XBT Z925 XBT Z935

Equivalent product table - Connection cables to third party PLCs										
Mitsubishi (Melsec®) PLCs										
Old range XBT G2●●0...G6330					New range XBT GT2●●0...GT6330					
Type of terminal	Type of connectors	Physical link	Length	Substituted reference	Type of terminal	Type of connectors	Physical link	Length	New reference + adaptor	
Q Link (SIO) protocol										
XBT G	SUB-D 25/SUB-D 9	COM1, RS 232C	3 m	XBT ZG9771	XBT GT	SUB-D 9/SUB-D 9	COM1, RS 232C	5 m	XBT ZG9772	
A Link (SIO) protocol										
XBT G	SUB-D 25/SUB-D 25	COM1, RS 232C	5 m	XBT ZG973	XBT GT	SUB-D 9/SUB-D 25	COM1, RS 232C	5 m	XBT ZG9731	
	SUB-D 25/SUB-D 9	COM1, RS 232C	3 m	XBT ZG9771						
Q FX (CPU) protocol										
XBT G	SUB-D 25/SUB-D 25	COM1, RS 422	5 m	XBT ZG9770	XBT GT	SUB-D 9/mini-DIN	COM1, RS 422	5 m	XBT ZG9775	
2 port adaptor, FX (CPU), A CPU (SIO) and QnA CPU (SIO) protocols										
XBT G	SUB-D 25/free wires other end	COM1, RS 422	5 m	XBT ZG9777	XBT GT	SUB-D 9/free wires other end	COM1, RS 422	5 m	XBT ZG9778 + XBT ZGCOM1	
Adaptor unit, FX (CPU), A CPU (SIO) and QnA CPU (SIO) protocols										
XBT G	2-port unit Screw terminals/ 2 x SUB-D 9	COM1, RS 422	-	XBT ZG979	XBT GT	2 port unit Screw terminals/ 2 x SUB-D 9	COM1, RS 422	-	XBT ZG979	
Adaptor unit, A Link (SIO) and Q Link (SIO) protocols										
XBT G	1 port unit Screw terminals/ 1 x SUB-D 25	COM1, RS 422	-	XBT ZG989	XBT GT	-	-	-	-	

Equivalent product table - Connection cables to third party PLCs (continued)									
Omron (Sysmac®) PLCs									
Old range XBT G2●●0...G6330					New range XBT GT2●●0...GT6330				
Type of terminal	Type of connectors	Physical link	Length	Substituted reference	Type of terminal	Type of connectors	Physical link	Length	New reference
Link (SIO) protocol									
XBT G	SUB-D 9/SUB-D 9	COM2, RS 232C	5 m	XBT ZG9740	XBT GT	SUB-D 9/SUB-D 9	COM1, RS 232C	5 m	XBT ZG9740
	SUB-D 25/SUB-D 25	COM1, RS 232C	5 m	XBT ZG973		SUB-D 9/SUB-D 25	COM1, RS 232C	5 m	XBT ZG 9731
FINS (SIO) protocol									
XBT G	SUB-D 25/SUB-D 9	COM1, RS 232C	2.5 m	XBT Z9740	XBT GT	SUB-D 9/SUB-D 9	COM1, RS 232C	5 m	XBT ZG9740
Rockwell Automation (Allen-Bradley) PLCs									
Old range XBT G2●●0...G6330					New range XBT GT2●●0...GT6330				
Type of terminal	Type of connectors	Physical link	Length	Substituted reference	Type of terminal	Type of connectors	Physical link	Length	New reference
DF1 Full Duplex protocol									
XBT G	SUB-D 25/SUB-D 25	COM1, RS 232C	5 m	XBT ZG973	XBT GT	SUB-D 9/SUB-D 25	COM1, RS 232C	5 m	XBT ZG 9731
Siemens (Simatic®) PLCs									
Old range XBT G2●●0...G6330					New range XBT GT2●●0...GT6330				
Type of terminal	Type of connectors	Physical link	Length	Substituted reference	Type of terminal	Type of connectors	Physical link	Length	New reference
MPI (S7-300/400) protocol									
XBT G	SUB-D 25/SUB-D 9	COM1, RS 232C	3 m	XBT ZG929	XBT GT	SUB-D 9/SUB-D 9	COM1, RS 232C	3 m	XBT ZG9292
						RJ45/SUB-D 9	COM2, RS 485	2.5 m	XBT ZG9721
Adaptor unit, RK512/3964F (S7-300/400) protocol									
XBT G	1 port unit Screw terminals/ 1 x SUB-D 25	COM1, RS 422	3 m	XBT ZG989	XBT GT	–	–	–	–

1

Dimensions

XBT N

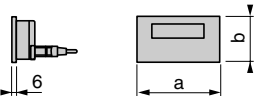
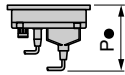

XBT R

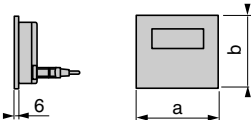
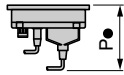

XBT RT

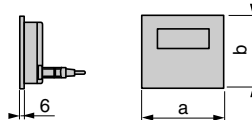
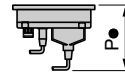

	a	a1 (1)	b	b1 (1)	P1 (2)	P2 (3)	P3 (4)	P4 (5)
XBT N200/N400	132	–	74	104	78	–	–	–
XBT N401/N410	132	–	74	104	–	–	58	104
XBT NU400	132	–	74	104	–	104	–	–
XBT R400	137	160	118	146	78	–	–	–
XBT R410/R411	137	160	118	146	–	–	58	104
XBT RT	137	160	118	146	79	104	58	104

(1) With fixing clips (included with product).

(2) P1: depth with RJ45 cable XBT Z9780 (for Twido®, TSX Micro™ and Premium™).

(3) P2: depth with 25-pin SUB-D cable XBT Z938 (for TeSys® model U and variable speed drives Altivar® 61/71).

(4) P3: depth with 25-pin SUB-D elbowed connector XBT Z9680 (for Twido, TSX Micro and Premium) or XBT Z998 (for Advantys™ STB).

(5) P4: depth with 25-pin SUB-D cable XBT Z68/Z9681 (for Twido, TSX Micro and Premium).

Dimensions

XBT GT1100/GT1130/GT1335

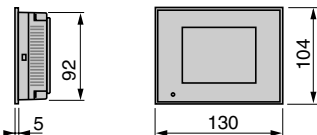
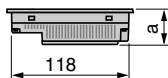

XBT GT1100/1130: a = 41; XBT GT1335: a = 40

XBT GT2110

XBT GT2120/GT2130/GT2220/GT2330

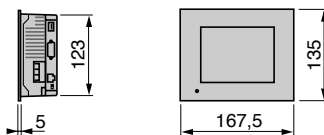
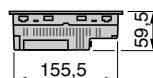

XBT GT4230/GT4330/GT4340

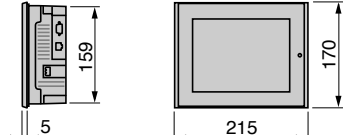
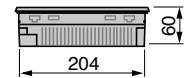

XBT GT 5230 and XBT GT 6330/GT 6340

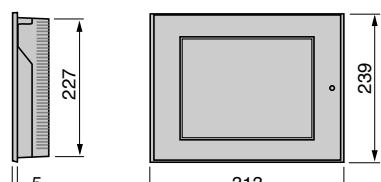
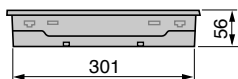

XBT GT 5330/GT 5340

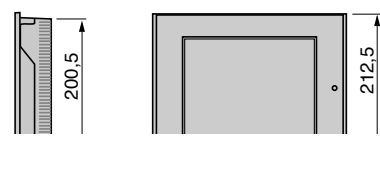
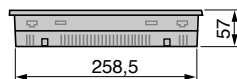

XBT GT 7340

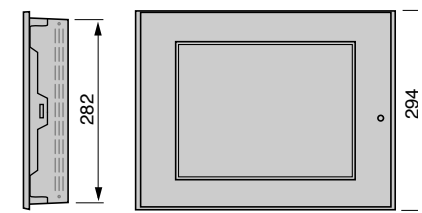
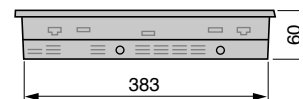

Mounting

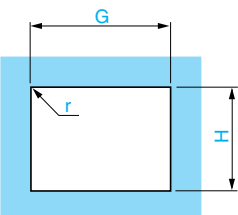

T = panel thickness

Graphic terminals

Cut-out for flush mounting

	H (± 0.4 mm)	G (± 0.5 mm)	r	T
XBT N	63	119.4	1.5 max.	1.5...6
XBT R	105.2	119.6	1.5 max.	1.5...6
XBT RT	105.2	119.6	1.5 max.	1.5...6
XBT GT1100/GT1130/GT1335	92.5 (+1/-0)	118 (+1/-0)	3 max.	1.6...5
XBT GT2110/GT2120/GT2130/GT2220/GT2330	123.5 (+1/-0)	156 (+1/-0)	3 max.	1.6...5
XBT GT4230/GT4330/GT4340	159.5 (+1/-0)	204.5 (+1/-0)	3 max.	1.6...10
XBT GT5230/GT6330/GT6340	227.5 (+1/-0)	301.5 (+1/-0)	3 max.	1.6...10
XBT GT5330/GT5340	201 (+1/-0)	259 (+1/-0)	3 max.	1.6...10
XBT GT7340	282.5 (+1/-0)	383.5 (+1/-0)	3 max.	1.6...10

XBT N references:
page 1/14

XBT R references:
page 1/16

XBT RT references:
page 1/20

XBT GT references:
page 1/50

Dimensions

XBT GK2120/GK2330/GK5330

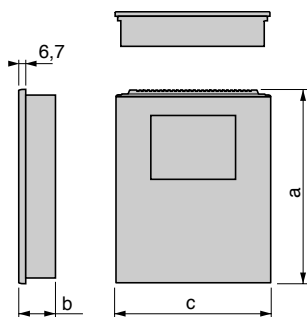

XBT GK2120/2330: a = 265, b = 60.3, c = 220.3
 XBT GK5330: a = 332, b = 72.7, c = 296

XBT GH 2460

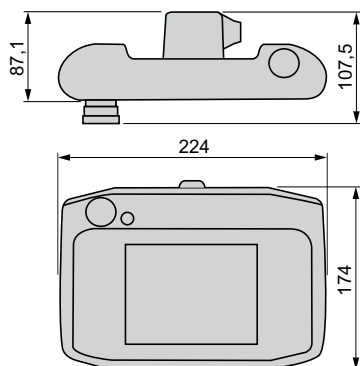

XBT GTW 450

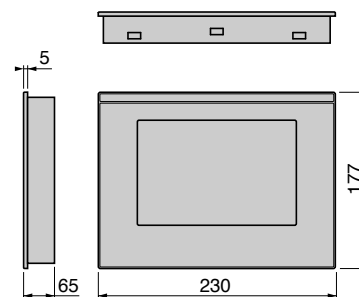

XBT GTW 652

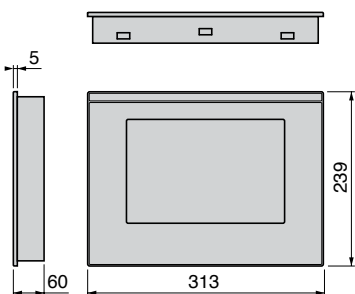

XBT GTW 750

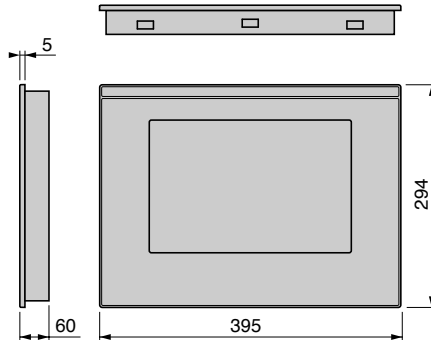

Mounting

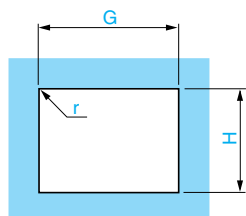

T = panel thickness

Graphic terminals

Cut-out for flush mounting

	H	G	r	T
XBT GK2120/GK2330	243 (+/-0.4)	209 (+/-0.4)	3 max.	1.6...10
XBT GK5330	309 (+/-0.4)	285 (+/-0.4)	3 max.	1.6...10
XBT GTW 450	165.5 (+1/-0)	218.5 (+1/-0)	3 < r < 4	1.6...10
XBT GTW 652	227.5 (+1/-0)	301.5 (+1/-0)	3 < r < 4	1.6...10
XBT GTW 750	282.5 (+1/-0)	383.5 (+1/-0)	3 < r < 4	1.6...10

2.1 - Magelis® Smart Embedded Panels and Magelis® Compact iPC PC Panels

Selection guide 2/2

- Magelis Smart Embedded Panels 8.4", 12", 15" 2/4
- Magelis Compact iPC PC Panels 8.4", 12", 15" 2/12
- Equivalent product tables for Magelis Smart Embedded Panels 2/22
- Equivalent product tables for Magelis Compact iPC PC Panels 2/23

2.2 - Magelis® Smart BOX, Magelis® Compact PC BOX, Magelis® Flex PC BOX and Front Panels

Selection guide 2/24

- Magelis Smart BOX 2/39
- Magelis Compact PC BOX 2/40
- Magelis Flex PC BOX 2/41
- Front panels for Magelis Flex PC BOX 2/43
- Separate parts for Magelis Flex PC BOX 2/44
- Separate parts for all Magelis iPC ranges 2/45
- Dimensions, mounting 2/46
- Connections 2/50

2.3 - Magelis® iDisplay flat screens

Selection guide 2/52

- Magelis iDisplay flat screens 2/54

2.4 - Magelis® HMI Controller

- Magelis XBT GC Compact HMI Controller 2/55

PC Panels



Magelis® Compact iPC

●		
	●	
		●

Magelis Compact iPC

Intel® Celeron® M 1 GHz	Intel Celeron M 1.5 GHz	Pentium® M 1.6 GHz
Hard disk ≥ 80 GB	Hard disk ≥ 160 GB or Flash Disk ≥ 15 GB	Hard disk ≥ 80 GB or Flash Disk ≥ 15 GB
512 MB expandable to 1024 MB		512 MB expandable to 2 GB
–	–	Yes
–	–	Yes
1 PCI bus slot	1 PCI bus slot 1 PCMCIA slot 1 x type III/type I	1 PCI bus slot 1 PCMCIA slot 1 x type III or 2 x type II
2 RJ45 ports: 1 x 10/100/1000BASE-T 1 x 10/100BASE-T		
–	1 x USB 2.0	
4 x USB 2.0, 1 x COM1, 1 x COM2, 1 x audio	4 x USB 2.0, 1 x COM1, 1 x audio, 1 x RAS	4 x USB 2.0, 1 x COM1, 1 x COM2, 1 x COM3, 1 x COM4, 3 x audio, 1 x RAS

Windows XP® Pro

MPC KT1 2NAX 00N	MPC KT2 2NAX 20N (1)	MPC KT5 5NAX 20N
		MPC KT5 5NDX 20N
MPC KT1 2NAX 00H (3)	(1)	MPC KT5 5NAX 20H (3)
		MPC KT5 5NDX 20H (3)
	MPC KT2 2MAX 20N (1)	MPC KT5 5MAX 20N
	(1)	MPC KT5 5MAX 20H (3)
	MPC KT2 2MAX 20L/V	

2/19 and 2/20

Introduction

Magelis® Smart embedded panels combine all the benefits of an industrial PC with those of an operator terminal for client applications developed in the Windows® operating system. Simple and user-friendly, it offers the flexibility of Windows XP® Embedded for standard client applications such as Internet Explorer®, Outlook® Express, Microsoft Office® readers, etc. As an operator terminal, Magelis Smart is, of course, open to HMI Vijeo Designer™ applications as well as to Vijeo® Citect® Web Client SCADA client applications.

Complementing the Magelis Compact iPC and PC BOX ranges, this renewed range offers "All in One" products that meet the needs of machine manufacturers, system integrators and users. They are more compact, very easy to install/set-up and open to Web technologies.

With identical dimensions and same screen size as the Magelis XBT GT terminals, and equally compatible with Vijeo Designer™ software, Magelis Smart (and Compact iPC) industrial PCs are the natural extension to the earlier terminals. They provide optimal flexibility for all operator dialog applications, from the simplest to the most advanced.

Magelis® Smart industrial PCs

Magelis Smart industrial PCs are built around an IP 65 front panel with an 8.4", 12" or 15" color TFT LCD screen and a high definition analog touch panel.

They have two built-in Ethernet TCP/IP ports:

- 1 x 10/100/1000BASE-T
- 1 x 10/100BASE-T

These two ports make the terminal perfectly suited for use with Transparent Ready® architectures and equipment (combination of Web and Ethernet TCP/IP technologies).

Magelis Smart is available in two pre-installed software configurations, supplied on a 1 GB or 2 GB Compact Flash memory card.

■ **Magelis® Smart Client Edition** enables the viewing of Web pages, either locally or remotely, with the same level of ease. A "ready to use" thin client station, Magelis Smart integrates the following software components:

- Internet Explorer® browser and Outlook® Express message client,
- JVM® (Java® Virtual Machine),
- Windows® Terminal Services Client for client/server architectures,
- Office Reader for access to device documentation (.pdf, .doc, .xls and .ppt documents).
- Vijeo® Citect® Web Client for Magelis Smart 12" and 15".

These components can be used for the system diagnostics, viewing and setting of Schneider Electric Transparent Ready® products, as well as for access to FactoryCast™ services (see "Transparent Ready, embedded Web servers). Magelis Smart 12" becomes HMI Edition following activation of a license (ref. **VJDSNRTMPC**), which is sold separately (one license per station).

■ **Magelis® Smart Edition HMI** utilizes Vijeo Designer™ Run Time, as well as offering the same functions as the Client Edition and same readiness for use after initial start-up. It also features Vijeo Designer Run Time control software.

Magelis Smart is based on standard Windows XP Embedded SP2 technologies. As well as built-in Ethernet TCP/IP ports, Magelis Smart also has a PCMCIA card slot that can be used for network access (Modbus®, Modbus Plus™, Fipway®, etc.). The Magelis Smart has particularly generous USB connectivity capabilities, featuring 4 or 5 (1) USB ports, depending on the model. With ultra-slim (depths of 60 and 65 mm), Magelis Smart is particularly robust due to a construction that does not include any vulnerable components (hard disk, fan, CD-ROM drive, etc.). Windows XP Embedded and the component software tools are pre-loaded onto a "ready to use" Compact Flash memory.

(1) 4 + 1 on front panel.

Architecture examples

Connections to Vijeo Citect architectures

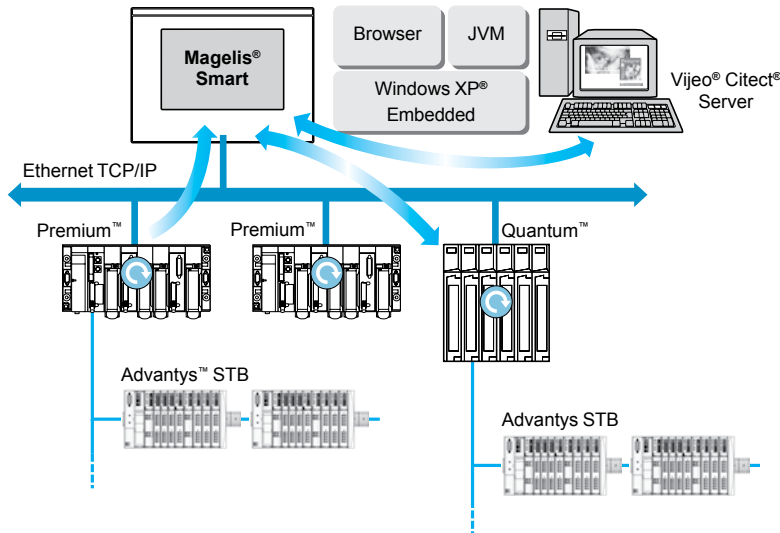

With its double integrated Ethernet port, Magelis® Smart embedded panels can be integrated into “full Ethernet” architectures, such as Transparent Ready®. Transparent Ready devices with this type of architecture enable transparent communication on the Ethernet TCP/IP network. Communication services and Web services assure the sharing and distribution of data between levels 1, 2 and 3 of the Transparent Ready architecture.

Used as a Client station, Magelis Smart makes it easier to implement Web Client solutions for:

- Base servers embedded in field devices (Advantys™ STB/Momentum™ distributed I/O, Altivar® 71/38/58 starters, OSitrack™ identification systems, etc.)
 - FactoryCast™ Web servers embedded in Modicon® PLCs (TSX Micro™, Premium™ and Quantum™) or the FactoryCast gateway.
- The following services are available as standard (without the need for additional programming): alarm management, synoptic view management and Web home pages created by the user.
- FactoryCast HMI Web servers embedded in Modicon Premium and Quantum PLCs also provide basic data management services, automatic e-mail sending triggered by specific process events and arithmetic and logic calculations for data preprocessing.
 - Web Client Vijeo® Citect®: With the pre-installed Vijeo Citect Web Client software and by using Internet Explorer®, Magelis Smart 12" and 15" are web clients of a Vijeo Citect server. The Web Client license must be activated on the Vijeo Citect server.

HMI applications in traditional architectures (Fipway®, Modbus Plus™)

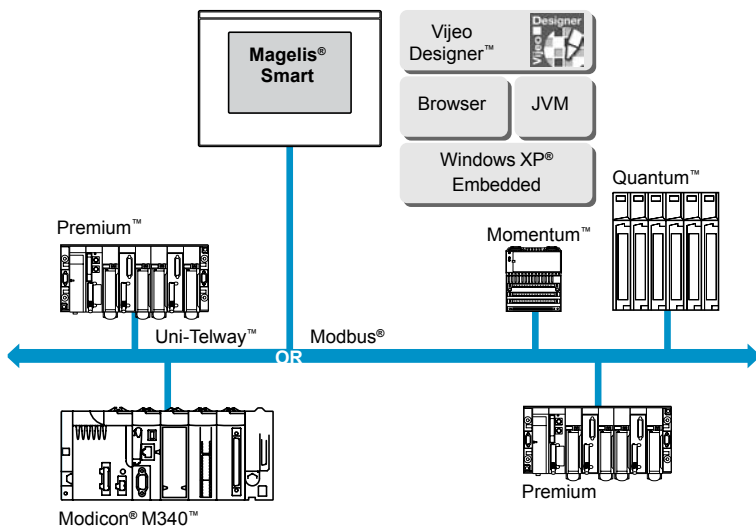

The combined offer comprised of Smart industrial PC and pre-installed Vijeo Designer™ control software allows them to be used in mono-network architectures such as Uni-Telway™/Modbus® or Fipway®/Modbus Plus™. For Uni-Telway, an RS 485 TSX SCP 114 card (1) needs to be inserted into a PCMCIA slot. For a Modbus link, one of the built-in RS 232C COM ports is used. For Fipway or Modbus Plus, network interfaces need to be added:

- Fipway network with the PCMCIA TSX FPP 20 (1) or TSX CUSB FIP card. (1).
- Modbus Plus network with the PCMCIA card TSX MBP 100 or the PCI bus card 416 NHM 300 30.

The built-in Ethernet TCP/IP port allows Modicon® PLC stations to be connected to levels 2 and 3 of communication architectures, if required. Ready to use, Magelis Smart 8.4" **MPC ST1 1NAJ 00H** and Magelis Smart 15" **MPC ST5 2NAJ 20H** (page 2/9) can be used with these HMI applications without the addition of separate components. Magelis Smart 12" **MPC ST2 1N●J 20T** becomes HMI Edition following activation of a license (ref. **VJDSNRTMPC**), which is sold separately (one license per station).

(1) Requires the "X-Way drivers" CD-ROM, TLX CD DRV20M.

2



Magelis® Smart Embedded Panels

8.4" touch screen front panel MPC ST1 1N●J 00●

The touch screen front panel of the industrial PC **MPC ST1 1N●J 00●** includes:

- 1 8.4" SVGA active matrix color TFT LCD screen (maximum display area 800 x 600 points) with high definition analog touch panel.
- 2 Aluminum alloy front panel with IP 65 membrane (mounted on a treated steel frame).
- 3 Two LEDs marked:
 - ON (green), PC switched on,
 - DISK (green), accessing IDE bus (accessing Compact Flash memory, etc.).

Lower and left-hand sides, 8.4"

Expansion slots and connection elements are accessible from the rear of the PC, with the following elements located on the lower and left-hand sides:

- 1 Removable screw terminal block for connecting $\overline{\text{---}}$ 24 V power supply.
- 2 Slot for the Compact Flash memory card containing the operating system and integrated software.
- 3 Two 9-pin male SUB-D connectors marked COM1 and COM2 for the RS 232 serial link.
- 4 Four USB 2.0 ports.
- 5 Two RJ45 connectors for Ethernet link:
 - 1 x 10/100/1000 Mbps
 - 1 x 10/100 Mbps
- 6 Mini-jack connector for loudspeaker.

Note: AC versions have an On/Off switch.

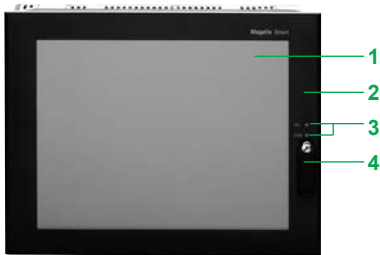
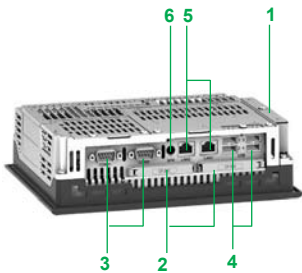

12" touch screen front panel MPC ST2 1N●J 20T

The touch screen front panel of the industrial PC **MPC ST2 1N●J 20T** includes:

- 1 12" SVGA active matrix color TFT LCD screen (maximum display area 800 x 600 points) with high definition analog touch panel.
- 2 Aluminum alloy front panel with IP 65 membrane (mounted on a treated steel frame).
- 3 2 lamps marked:
 - ON (green), PC switched on,
 - DISK (green), accessing IDE bus (accessing Compact Flash memory, etc.).
- 4 Dust and moisture protected USB port.

Lower and left-hand sides, 12"

Expansion slots and connection elements are accessible from the rear of the PC, with the following elements located on the lower and left-hand sides:

- 1 Removable screw terminal block for connecting AC supply.
- 2 Slot for the Compact Flash memory card containing the operating system and integrated software.
- 3 One 9-pin male SUB-D connector marked COM1 for the RS 232 serial link.
- 4 Four USB 2.0 ports.
- 5 Two RJ45 connectors for Ethernet link:
 - 1 x 10/100/1000 Mbps
 - 1 x 10/100 Mbps
- 6 Slot for 1 additional type II PCMCIA card.
- 7 Mini-jack connector for loudspeaker.
- 8 RAS connector.

Note: AC versions have an On/Off switch.

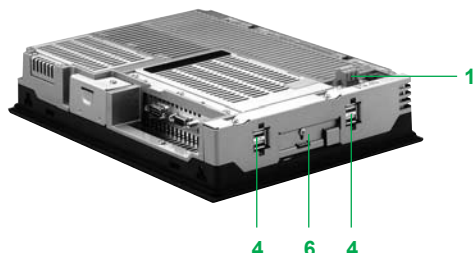
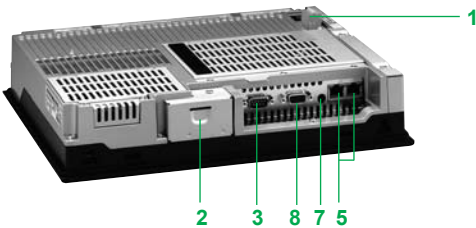

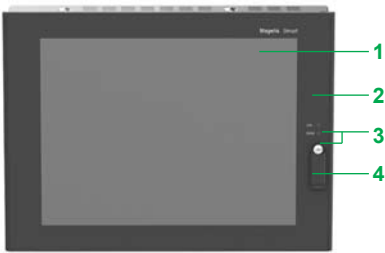

15" touch screen front panel MPC ST5 2N●J 20●

The touch screen front panel of the Magelis® industrial PC MPC ST5 2N●J 20● features:

- 1 15" XGA active matrix color TFT LCD screen (maximum display area 1024 x 768 points) with high definition analog touch panel.
- 2 Aluminum alloy front panel with IP 65 membrane (mounted on a treated steel frame).
- 3 Two LEDs marked:
 - ON (green), PC switched on,
 - DISK (green), accessing IDE bus (accessing Compact Flash memory, etc.).
- 4 Dust and moisture protected USB port.

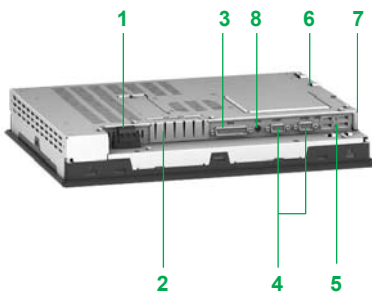

Lower and left-hand sides, 15"

Expansion slots and connection elements are accessible from the rear of the PC, with the following elements located on the lower and left-hand sides:

- 1 Removable screw terminal block for connecting $\pm 24\text{ V}$ power supply.
- 2 Slot for the Compact Flash memory card containing the operating system and integrated software.
- 3 25-pin female SUB-D connector marked RAS for diagnostics.
- 4 Two 9-pin male SUB-D connectors marked COM1 and COM2 for the RS 232 serial link.
- 5 Four USB 2.0 ports.
- 6 Two RJ45 connectors for Ethernet link:
 - 1 x 10/100/1000 Mbps
 - 1 x 10/100 Mbps
- 7 Slot for 2 additional PCMCIA cards.
- 8 Mini-jack connector for loudspeaker.

Note: AC versions have an On/Off switch.

Specifications				
Front panel characteristics				
Type		Smart 8.4" MPC ST1 1N●J 00●	Smart 12" MPC ST2 1N●J 20T	Smart 15" MPC ST5 2N●J 20●
Touch screen	Type	8.4" SVGA active matrix color TFT LCD	12" SVGA active matrix color TFT LCD	15" XGA active matrix color TFT LCD
	Definition	800 x 600		1024 x 768
	Number of colors	262144		16 777 216
	Brightness	≥ 200 cd/m ² , adjustable	≥ 250 cd/m ² , adjustable	
	Optimum viewing angle	Horizontal 160°, vertical 160°		
Touch panel		Analog resistive, 1 million cycles		
Front panel	Signalling	ON LED: PC switched ON - DISK LED: accessing Compact Flash system card		
	I/O ports		1 USB port, protected by IP 65 cover	
	Material	Aluminum alloy with IP 65 membrane on treated steel frame		
	Screen protection	Polyethylene sheet		
Degree of protection		IP 65	IP 65 (when USB port on front panel not in use)	IP 65, Nema® 4 (when USB port on front panel not in use)
CPU characteristics				
Type		Smart 8.4" MPC ST1 1N●J 00●	Smart 12" MPC ST2 1N●J 20T	Smart 15" MPC ST5 2N●J 20●
Processor		Intel® Celeron® M 600 MHz	Intel Celeron M 1 GHz	Intel Celeron M 600 MHz
Storage	Internal hard disk			
	Compact Flash card	1 primary slot with a 1 GB min. card, expandable to 4 GB, loaded with the OS and software + 1 extra secondary slot	1 slot with a 2 GB minimum card, expandable to 4 GB, loaded with the OS and software	
RAM (1 memory slot)	MB	SDRAM, 256 minimum, expandable to 1024	SDRAM, 512, expandable to 1024	SDRAM, 256 minimum, expandable to 1024
CD-ROM drive				
Floppy disk drive				
Expansion slots	PCMCIA cards		1 slot (taking a maximum of 1 x type II card)	1 slot (taking a maximum of 1 x type III card or 2 x type I cards)
	PCI port			
Built-in I/O ports	Ethernet TCP/IP port	2 RJ45 ports, links: 1 x 10/100/1000BASE-T and 1 x 10/100BASE-T		
	USB ports	4 USB 2.0 ports		
	Serial port COM1	1 RS 232C link (9-pin male SUB-D connector)		
	Serial port COM2	1 RS 232C link (9-pin male SUB-D connector)		1 RS 232C link (9-pin male SUB-D connector)
	Audio	1 mini-jack LINE output		
	PS/2 keyboard port			
	PS/2 pointing device port			
Operating system		Windows XP® Embedded SP2 installed (1)		
Pre-installed software		Internet Explorer® (1)		
		Adobe® Acrobat® Reader, Microsoft® Word/Excel®/PowerPoint® reader (1)		
		Vijeo Designer™ Run Time (1) (2)		
			Vijeo® Citect® Web Client Framework .NET	
Power supply	Voltage	--- 24 V ~ 100 to 240 V with external AC power supply	--- 24 V ~ 100 to 240 V (voltage limits 85 to 265 V), conforming to EN 61131-2	--- 24 V ~ 100 to 240 V
	Frequency	Hz	50/60 (frequency limits 47/63), conforming to EN 61131-2	
	Micro-breaks	ms	5	5 (---) 10 (~)
Consumption		40 W max.	40 W max. (---) 95 VA max. (~)	90 W max.
Material		Treated steel		
Mounting		On panel or enclosure door (8 fixing bolts included)		
Environment	Certifications	UL 508, CSA 142, IEC 61131-2		
				UL 1604 (HazLoc Class 1 Div 2) (DC version only)
	Immunity to interference	High frequency interference, conforming to IEC 61131-2, EN 61000-6-2, FCC (Class A) Electromagnetic emissions, EN 55011 (Group 1, Class A), EN 61000-3-2, EN 61000-3-3		
	Temperature	°C	0 to +50	
	Operation	°C	-20 to +60	-10 to +60
Storage	°C			
Relative humidity	%	10 to 85		
Operating altitude	m	0 to 3000 max.		
Storage altitude	m	0 to 12 000 max.		
Vibration resistance	m/s ²	9.8 at 10 to 25 Hz/3 axes for 30 minutes		

(1) Installed in Compact Flash memory.
(2) See references on page 2/9.

References

Magelis® Smart

Magelis® Smart industrial PCs are “rugged” PCs that do not include components likely to impair reliability (hard disk, CD-ROM drive, etc). They are fitted with an 8.4", 12" or 15" active matrix back-lit color TFT LCD touch screen.

■ The 8.4" model **MPC ST1 1NDJ 00T** has a 24 V power supply. For use on AC it requires an external AC power supply.

Models **MPC ST1 1NAJ 00●** include an external AC power supply for mounting in the back of the cabinet.

■ The 12" models **MPC ST2 1N●J 20T** and 15" models **MPC ST5 2N●J 20●** are available in 24 V and ~ 100 to 240 V versions.

Magelis Smart industrial PCs feature the Windows XP® Embedded SP2 operating system and two “ready to use” editions:

■ **Client Edition: MPC ST●●N●J ●0T**, with the following application software pre-installed on Compact Flash memory card:

- Internet Explorer® for browsing the Web (Internet/Intranet),
- Windows® Terminal Services Client for client/server architectures,
- Readers for Microsoft® Word (.doc), Excel® (.xls), PowerPoint® (.ppt) and Acrobat® (.pdf) files.

■ **HMI Edition - Vijeo Designer RT: MPC ST●●N●J ●0●**, with the software listed above pre-installed on Compact Flash card, plus:

- Vijeo Designer™ Run Time software.

Smart - 8.4" Heavy Duty screen

With 1 GB Compact Flash

Supply voltage	RAM Processor	Expansion slots available	Edition	Reference	Weight kg
24 V	Celeron® M 600 MHz 256 MB expandable to 1024 MB	–	Client Edition	MPC ST1 1NDJ 00T	3.500
~ 100 to 240 V	Celeron M 600 MHz 256 MB expandable to 1024 MB		Client Edition	MPC ST1 1NAJ 00T	3.500
			HMI Edition - Vijeo Designer™ RT	MPC ST1 1NAJ 00H (2)	3.500



MPC ST1 1N●J 00●

Smart - 12" Heavy Duty screen

With 2 GB Compact Flash

Supply voltage	RAM Processor	Expansion slots available	Edition	Reference	Weight kg
24 V	Celeron M 1 GHz 512 MB, expandable to 1024 MB	1 PCMCIA	Client Edition (1)	MPC ST2 1NDJ 20T	3.800
~ 100 to 240 V	Celeron M 1 GHz 512 MB, expandable to 1024 MB	1 PCMCIA	Client Edition (1)	MPC ST2 1NAJ 20T	3.800



MPC ST2 1NAJ 10●

Smart - 15" Heavy Duty screen

With 2 GB Compact Flash

Supply voltage	RAM Processor	Expansion slots available	Edition	Reference	Weight kg
24 V	Celeron M 600 MHz 256 MB minimum, expandable to 1024 MB	2 PCMCIA	Client Edition	MPC ST5 2NDJ 20T	6.000
~ 100 to 240 V	Celeron M 600 MHz 256 MB minimum, expandable to 1024 MB	2 PCMCIA	Client Edition	MPC ST5 2NAJ 20T	6.000
			HMI Edition Vijeo Designer RT	MPC ST5 2NAJ 20H (2)	6.000



MPC ST5 2N●J 20●

(1) HMI Edition version following activation of a **Magelis iPC Runtime with Vijeo Designer V5.1 minimum license**.

(3) HMI Runtime Editions will soon be replaced by the client edition + VJDSNRTMPC. For example, MPCST52NAJ20H will become MPCST52NAJ20T + VJDSNRTMPC.

Industrial PCs

Magelis® Smart Embedded Panels

Separate components for Smart				
Description	Size - software	Compatible with	Reference	Weight kg
RAM expansion	512 MB	8.4" models MPC ST1 1N●J 00●	MPC YK0 5RAM 512	–
		12" models MPC ST2 1N●J 20●	MPC YK0 5RAM 512	–
		15" models MPC ST5 2N●J 20●	MPC YK0 5RAM 512	–
	1024 MB	8.4" models MPC ST1 1N●J 00●	MPC YK2 2RA1 024	–
		12" models MPC ST2 1N●J 20●	MPC YK2 2RA1 024	–
		15" models MPC ST5 2N●J 20●	MPC YK2 2RA1 024	–
Compact Flash memory cards	128 MB, blank	All Smart models	XBT ZGM128	0.050
	256 MB, blank		XBT ZGM256	0.050
	512 MB, blank		MPC YN0 0CFE 00N	0.050
	1 GB, blank		MPC YN0 0CF1 00N	–
	2 GB, blank		MPC YN0 0CF2 00N	–
	4 GB, blank		MPC YN0 0CF4 00N	–
	1 GB, Client Edition software pre-installed	8.4" models MPC ST1 1N●J 00●	MPC YN1 1CF1 10T	–
	1 GB, HMI Edition Vijeo Designer™ RT software pre-installed	8.4" models MPC ST1 1N●J 00●	MPC YN1 1CF1 10H (1)	–
	2 GB, with pre-installed software: Windows XP® Embedded SP2 in 9 languages (English, French, German, Italian, Portuguese, Russian, Spanish, Swedish and Chinese), Framework .NET® RT, Web Application and Vijeo Designer™ Run Time	8.4" models MPC ST1 1N●J 00●	MPC YN1 1CF2 10H (1)	–
	2 GB, Client Edition, with pre-installed software: Windows XP Embedded SP2 in 9 languages (English, French, German, Italian, Portuguese, Russian, Spanish, Swedish and Chinese), Framework .NET RT, Vijeo® Citect® Web Client, Office Readers	15" models MPC ST5 2N●J 20●	MPC YN5 2CF2 20T	–
2 GB, Client Edition, with pre-installed software: Windows XP Embedded SP2 in 9 languages (English, French, German, Italian, Portuguese, Russian, Spanish, Swedish and Chinese), Framework .NET RT, Vijeo Citect Web Client, Vijeo Designer Run Time, Office Readers	15" models MPC ST5 2N●J 20●	MPC YN5 2CF2 20H (1)	–	
PCMCIA adaptor for Compact Flash card	Enables a Smart industrial PC to receive the 2 nd Compact Flash card required by Vijeo Designer™ at the PCMCIA slot	All Smart models. All Compact Flash memory cards	XBT ZGADT	0.050
Maintenance kits	Includes panel mounting fixings and seals	8.4" models MPC ST1 1N●J 00T	MPC YK1 0MNT KIT	–
		12" models MPC ST2 1N●J 20●	MPC YK2 0MNT KIT	–
		15" models MPC ST5 2NDJ 10T	MPC YK5 0MNT KIT	–
Screen protection	Protective film for Smart industrial PCs	8.4" models MPC ST1 1N●J 00T	MPC YK1 0SPS KIT	–
		12" models MPC ST2 1N●J 20●	MPC YK2 0SPS KIT	–
		15" models MPC ST5 2NDJ 10T	MPC YK5 0SPS KIT	–
Replacement power supply connector	AC connector	All Smart models with AC power supply MPC ST●●NAJ●0●●	MPC YN0 0PWA CTE	–

(1) HMI Runtime Editions will soon be replaced by the client edition + VJDSNRTMPC. For example, MPCST52NAJ20H will become MPCST52NAJ20T + VJDSNRTMPC.

Dimensions

MPC ST1 1N●J00●/MPC ST2 1N●J 20●/MPC ST5 2N●J 20●

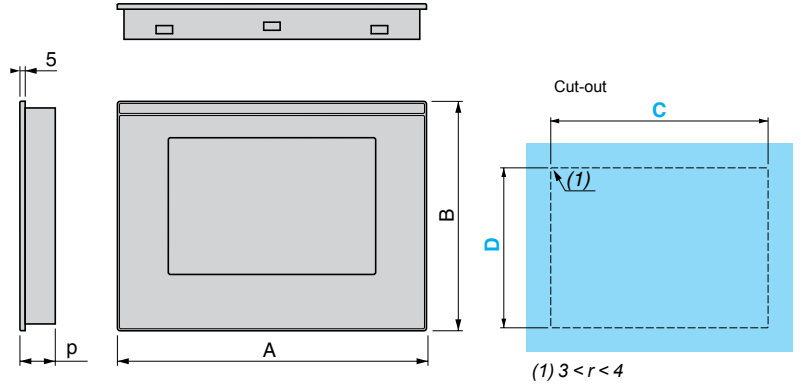

	A	B	C	D	p
MPC ST1 1N●J 00●	230	177	218.5 ⁺¹ ₀	165.5 ⁺¹ ₀	65.0
MPC ST2 1N●J 20●	313	239	301.5 ⁺¹ ₀	227.5 ⁺¹ ₀	60.0
MPC ST5 2N●J 20●	395	294	383.5 ⁺¹ ₀	282.5 ⁺¹ ₀	60.0



Industrial PCs

Magelis® Compact iPC PC Panels



Introduction

Magelis® Compact iPC provides an easy means of optimizing machine solutions, from the simplest to the most advanced.

With identical dimensions to Magelis XBT GT (1) terminals, Magelis Compact iPC industrial PCs are a logical extension (like Magelis® Smart panels).

Complementing the Magelis PC BOX range, this range of Magelis Compact iPC industrial PCs offers compact "All in One" products that meet the needs of machine manufacturers, system integrators and users. They are more compact, very easy to install/set-up and open to Web technologies.

Magelis® Compact iPC

Like Magelis Smart, Magelis Compact iPC industrial PCs are built around an IP 65 front panel with an 8.4", 12" or 15" color TFT LCD screen and a high definition analog touch panel.

Although compact in size, the Magelis Compact iPC is an open PC designed for open-ended solutions. It offers:

- The choice of 3 processor speeds: 1 GHz (Intel® Celeron® M), 1.5 GHz (Intel Celeron M) or 1.6 GHz (Intel® Pentium® M).

- The characteristics common to all 3 sizes of Magelis Compact iPC:

- 512 MB expandable RAM,
- optional expansion on PCI bus (1 slot),
- UL 508 certification,
- availability in ~ 100 to 240 V version

The 8.4" has a Celeron® M 1 GHz processor.

The 12" has a Celeron M 1.5 GHz processor, its hard disk (≥ 160 GB) is replaceable and it has a SATA interface. It is also available with a Flash Disk ≥ 15 GB and, for this, a type II PCMCIA slot is provided.

The 15" has a Pentium™ M 1.6 GHz processor, a hard disk ≥ 80 GB or a Flash Disk ≥ 15 GB depending on model and 2 slots for PCMCIA card that can take 1 type III or 2 type I cards. In addition, the 15" model is also available with ~ 24 V power supply.

Magelis Compact iPC also features:

- 512 MB to 1024 MB RAM (8.4" and 12"), 512 MB to 2 GB RAM (15"),
- 2 Ethernet TCP/IP ports:
 - 1 x 10/100/1000BASE-T,
 - 1 x 10/100BASE-T,
- USB 2.0 ports,
- ~ 100 to 240 V, 50/60 Hz power supply,
- Various standard serial/parallel ports.
- DVD drive (reader/writer) for 15".

The Magelis Compact iPC is supplied with the Windows XP® Pro operating system.

Combined software package

This offer includes Vijeo Designer™ Run Time control software or Vijeo® Citect® supervisory software as well as the hardware.

This offer provides an industrial system that is suited to specific application needs, at a competitive cost.

(1) Identical screen size.

Architecture examples

Connections to Transparent Ready® architectures

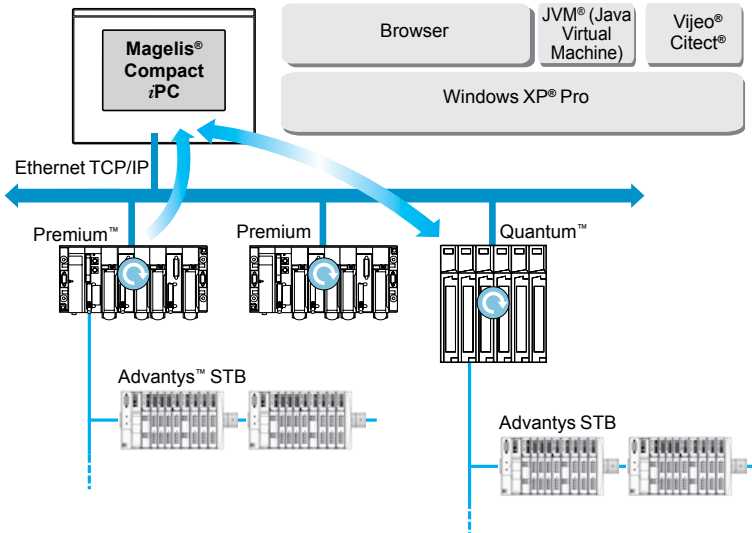

The built-in Ethernet ports on the Magelis® Compact iPC allow it to be integrated into “full Ethernet” architectures, such as Transparent Ready®. Transparent Ready devices with this type of architecture enable transparent communication on the Ethernet TCP/IP network. Communication services and Web services assure the sharing and distribution of data between levels 1, 2 and 3 of the Transparent Ready architecture.

Used as a Client station, the Magelis® Compact iPC makes it easier to implement Web Client solutions in relation to:

- Base servers embedded in field devices (Advantys™ STB/Momentum™ distributed I/O, Altivar® 71/38/58 starters, OSitrack™ identification systems, etc.)
- FactoryCast™ Web servers embedded in Modicon® PLCs (TSX Micro™, Premium™ and Quantum™) or the FactoryCast gateway.

The following services are available as standard (without the need for additional programming): alarm management, synoptic view management and Web home pages created by the user.

- FactoryCast HMI Web servers embedded in Modicon Premium and Quantum PLCs also provide basic data management services, automatic e-mail sending triggered by specific process events, and arithmetic and logic calculations for data preprocessing.

In addition, Vijeo® Citect® supervisory software is provided pre-installed on Heavy Duty type (15 GB minimum Flash Disk) Compact iPC models with 15" screen **MPC KT 55 MAX 20L** and **MPC KT 55 MAX 20V**.

HMI applications in traditional architectures (Fipway®, Modbus Plus™)

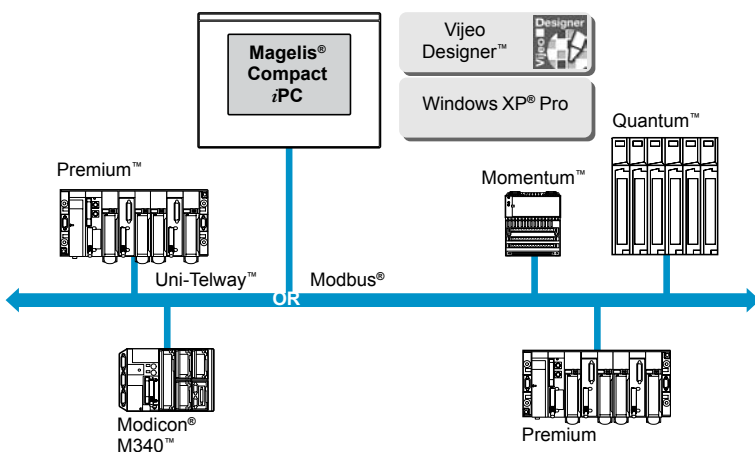

The combined offer comprising the Compact iPC industrial PC and pre-installed Vijeo Designer™ control software allows them to be used in mono-network architectures such as Modbus® or Fipway®/Modbus Plus®. For a Modbus link, one of the built-in RS 232C COM ports is used.

For Fipway or Modbus Plus, network adaptors need to be added:

- Fipway network with adaptor TSX CUSB FIP.
- Modbus Plus network with adaptor TSX CUSB MBP.

The built-in Ethernet TCP/IP port allows Modicon PLC stations to be connected to levels 2 and 3 of communication architectures, if required.

Industrial PCs

Magelis® Compact iPC PC Panels

2

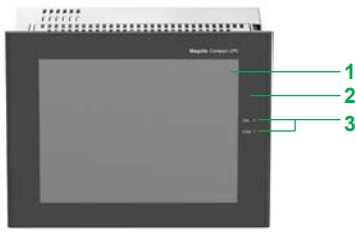

Description of the Compact iPC

8.4" touch screen front panel MPC KT1 2NAX 00●

The touch screen front panel of the 8.4" industrial PCs **MPC KT1 2NAX 00●** is comprised of:

- 1 8.4" SVGA active matrix color TFT LCD screen (maximum display area 800 x 600 points) with high definition analog touch panel.
- 2 Aluminum alloy front panel with IP 65 membrane (mounted on a treated steel frame).
- 3 Two LEDs marked:
 - ON (green), PC switched on,
 - DISK (green), accessing IDE bus (accessing hard disk memory, etc.).

Lower faces, 8.4"

Expansion slots and connection elements are accessible from the rear of the PC, with the following elements located on the lower side:

- 1 Connector for plugging-in the ~ 100 to 240 V power cable.
- 2 Vent fitted with a dust filter and fan.
- 3 Slot for additional Compact Flash memory card.
- 4 Two 9-pin male SUB-D connectors marked COM1 and COM2 for serial links (see details on page 2/16).
- 5 Four USB 2.0 ports.
- 6 Two RJ45 connectors for the Ethernet link:
 - 1 x 10/100/1000 Mbps
 - 1 x 10/100 Mbps
- 7 Slot for a PCI bus expansion card.

Note: AC versions have an On/Off switch.

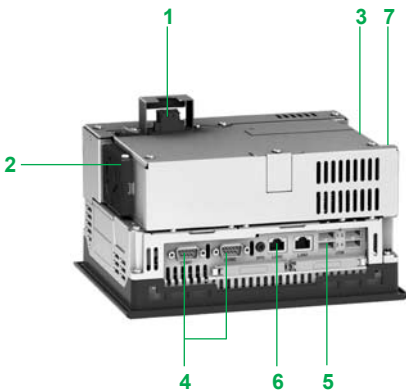

12" touch screen front panel MPC KT2 2●AX 20N

The touch screen front panel of the 12" industrial PCs **MPC KT2 2●AX 20N** is comprised of:

- 1 12" XGA active matrix color TFT LCD screen (maximum display area 1024 x 768 points) with high definition analog touch panel.
- 2 Aluminum alloy front panel with IP 65 membrane (mounted on a treated steel frame).
- 3 Two LEDs marked:
 - ON (green), PC switched on,
 - DISK (green), accessing IDE bus (accessing hard disk memory, etc.).
- 4 Sealing plate to maintain the IP 65 degree of protection when in place, and when removed, provides access to:
 - USB 2.0 port.
 - "Pencil point" RESET button for restarting the processor.

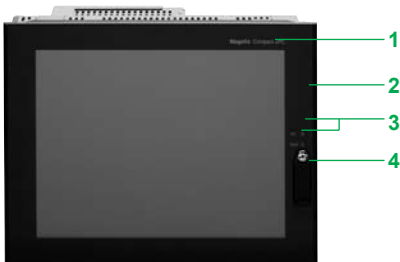

Lower and left-hand sides, 12"

Expansion slots and connection elements are accessible from the rear of the PC, with the following elements located on the lower, left-hand and right-hand sides:

- 1 Connector for plugging-in the ~ 100 to 240 V power cable.
- 2 Vent fitted with a dust filter and fan.
- 3 Slot for additional Compact Flash memory card.
- 4 One 9-pin male SUB-D port marked COM1 for serial links (see details on page 2/16).
- 5 Four USB 2.0 ports.
- 6 Slot for 1 additional PCMCIA card.
- 7 Two RJ45 connectors for the Ethernet link:
 - 1 x 10/100/1000 Mbps
 - 1 x 10/100 Mbps
- 8 Slot for a PCI bus expansion card.
- 9 RAS port.

Note: AC versions have an On/Off switch.

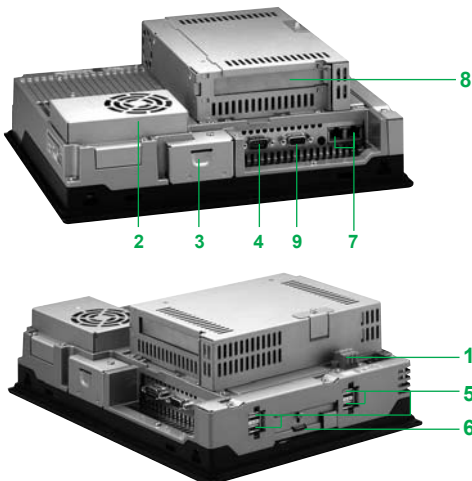

Industrial PCs

Magelis® Compact iPC PC Panels



15" touch screen front panel MPC KT5 5AX 20

The touch screen front panel of the 8.4" industrial PCs **MPC KT5 5AX 20** is comprised of:

- 1 15" XGA active matrix color TFT LCD screen (maximum display area 1024 x 768 points) with high definition analog touch panel.
- 2 Aluminum alloy front panel with IP 65 membrane (mounted on a treated steel frame).
- 3 Two LEDs marked:
 - ON (green), PC switched on,
 - DISK (green), accessing IDE bus (accessing hard disk memory, etc.).
- 4 Sealing plate to maintain the IP 65 degree of protection when in place, and when removed, provides access to:
 - USB 2.0 port,
 - "Pencil point" RESET button for restarting the processor.

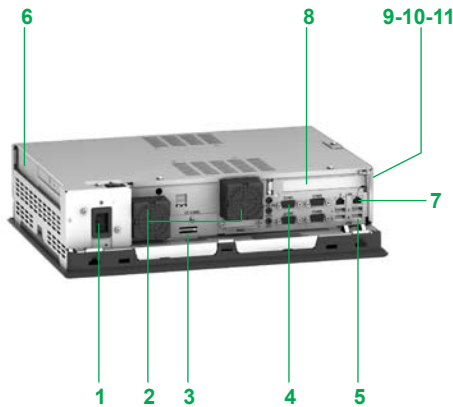

Lower faces, 15"

Expansion slots and connection elements are accessible from the rear of the PC, with the following elements located on the lower side:

- 1 Connector for plugging-in the ~ 100 to 240 V power cable.
- 2 Two vents, each fitted with a dust filter and fan.
- 3 Slot for additional Compact Flash memory card.
- 4 Four 9-pin male SUB-D connectors marked COM1, COM2, COM3 and COM4 for serial links (see details on page 2/16).
- 5 Four USB 2.0 ports.
- 6 Slot for 2 additional PCMCIA cards.
- 7 Two RJ45 connectors for the Ethernet link:
 - 1 x 10/100/1000 Mbps
 - 1 x 10/100 Mbps
- 8 Slot for a PCI bus expansion card.
- 9 DVD drive (reader/writer).
- 10 3.5" floppy disk drive.
- 11 VGA port.

Note: AC versions have an On/Off switch.

Specifications				
Front panel characteristics				
Type		Compact iPC 8.4" MPC KT1 2●AX 00●		
Touch screen	Size		8.4"	
	Type		SVGA active matrix color TFT LCD	
	Definition		800 x 600	
	Number of colors		262 144	
	Brightness		≥ 200 cd/m ² , adjustable	
	Optimum viewing angle		Horizontal 120°, vertical 100°	
Touch panel			Analog resistive, 1 million cycles	
Front panel	Signalling		ON LED: switched on, Disk LED: accessing hard disk	
	I/O ports		–	
	Material		Aluminum alloy with IP 65 membrane on treated steel frame	
	Screen protection		Polyethylene sheet	
Degree of protection			IP 65	
CPU characteristics				
Type		Compact iPC 8.4" MPC KT1 2NAX 00●		
Processor			Intel® Celeron® M 1 GHz	
Internal hard disk			≥ 80 GB IDE, 2.5"	
Flash Disk			–	
RAM	With Windows XP® Pro	MB	512 to 1GB SDRAM	
Memory slot			1 slot	
DVD-ROM drive (reader)			–	
Floppy disk drive			–	
Expansion slots	PCMCIA cards		–	
	PCI port		1 PCI bus slot	
Built-in I/O ports	Ethernet TCP/IP port		2 RJ45 ports, links: 1 x 10/100/1000BASE-T 1 x 10/100BASE-T	
	USB ports		4 USB 2.0 ports	
	Serial port COM1		1 RS 232C link (9-pin male SUB-D connector)	
	Serial port COM2		1 RS 232C link (9-pin male SUB-D connector)	
	Audio		1 line out	
	PS/2 keyboard port		–	
	PS/2 pointing device port		–	
	Operating system			Windows XP® Pro
Power supply	Voltage		~ 100 to 240 V (voltage limits 85 to 265 V), conforming to EN 61131-2	
	Frequency	Hz	50/60 (frequency limits 47/63), conforming to EN 61131-2	
	Micro-breaks	ms	20	
Consumption		VA	120 max.	
Material			Treated steel	
Mounting			On panel or enclosure door (8 fixing bolts included)	
Environment	Certifications		UL 508, CSA 142, IEC 61131-2	
	Immunity to interference		High frequency interference, conforming to IEC 61131-2, EN 61000-6-2, FCC (Class A) Electromagnetic emissions, EN 55011 (Group 1, Class A), EN 61000-3-2, EN 61000-3-3	
	Temperature	Operation	°C	+ 5 to + 50
		Storage	°C	- 20 to + 60
	Relative humidity		%	10 to 85
	Operating altitude		m	0 to 3000 max.
	Storage altitude		m	0 to 12 000 max.
Vibration resistance		m/s ²	9.8 at 10 to 25 Hz/3 axes for 30 minutes	

Specifications				
Front panel characteristics				
Type		Compact iPC 12" MPC KT2 2●AX 20N		
Touch screen	Size	12"		
	Type	XGA active matrix color TFT LCD		
	Definition	1024 x 768		
	Number of colors	262 144		
	Brightness	≥ 250 cd/m ² , adjustable		
	Optimum viewing angle	Horizontal 120°, vertical 100°		
Touch panel		Analog resistive, 1 million cycles		
Front panel	Signalling	ON LED: switched on, Disk LED: accessing hard disk		
	I/O ports	1 USB port (12 Mbps), protected by IP 65 cover		
	Material	Aluminum alloy with IP 65 membrane on treated steel frame		
	Screen protection	Polyethylene sheet		
Degree of protection		IP 65		
CPU characteristics				
Type		Compact iPC 12" MPC KT2 2NAX 20N		
Processor		Intel® Celeron® M 1.3 GHz		
Internal hard disk		≥ 160 GB IDE, 2.5", replaceable by user	≥ 15 GB IDE, 2.5", replaceable by user	
Flash Disk		–		
RAM	With Windows XP® Pro	MB	512 to 1 GB SDRAM	
Memory slot		1 slot		
DVD-ROM drive (reader)		–		
Floppy disk drive		–		
Expansion slots	PCMCIA cards	1 slot (taking a maximum of 1 x type II card)		
	PCI port	1 PCI bus slot		
Built-in I/O ports	Ethernet TCP/IP port	2 RJ45 ports, links: 1 x 10/100/1000BASE-T 1 x 10/100BASE-T		
	USB ports	4 USB 2.0 ports		
	Serial port COM1	1 RS 232C link (9-pin male SUB-D connector)		
	Serial port COM2	–		
	Audio	1 line out		
	PS/2 keyboard port	–		
	PS/2 pointing device port	–		
	Operating system		Windows XP® Pro	
Power supply	Voltage	~ 100 to 240 V (voltage limits 85 to 265 V), conforming to EN 61131-2		
	Frequency	Hz	50/60 (frequency limits 47/63), conforming to EN 61131-2	
	Micro-breaks	ms	10	
Consumption		VA	120 max.	
Material		Treated steel		
Mounting		On panel or enclosure door (8 fixing bolts included)		
Environment	Certifications		UL 508, IEC 61131-2, cUL	
	Immunity to interference		High frequency interference, conforming to IEC 61131-2, EN 61000-6-2, FCC (Class A) Electromagnetic emissions, EN 55011 (Group 1, Class A), EN 61000-3-2, EN 61000-3-3	
	Temperature	Operation	°C	+ 5 to + 50
		Storage	°C	- 10 to + 60
	Relative humidity		%	10 to 85
	Operating altitude		m	0 to 3000 max.
	Storage altitude		m	0 to 12 000 max.
	Vibration resistance		m/s ²	9.8 at 10 to 25 Hz/3 axes for 30 minutes

Industrial PCs

Magelis® Compact iPC

15" PC Panels

2

Specifications				
Front panel characteristics				
Type		Compact iPC 15"		
		MPC KT5 5●●X 20●		
Touch screen	Size	15"		
	Type	SVGA active matrix color TFT LCD		
	Definition	1024 x 768		
	Number of colors	16 777 216		
	Brightness	≥ 250 cd/m ² , adjustable		
	Optimum viewing angle	Horizontal 120°, vertical 100°		
Touch panel		Analog resistive, 1 million cycles		
Front panel	Signalling	ON LED: switched on, Disk LED: accessing hard disk		
	I/O ports	1 USB port (12 Mbps), protected by IP 65 cover		
	Material	Aluminum alloy with IP 65 membrane on treated steel frame		
	Screen protection	Polyethylene sheet		
Degree of protection		IP 65		
CPU characteristics				
Type		Compact iPC 15"		
		MPC KT5 5●●X 20●		
		MPC KT5 5MAX 20●		
Processor		Pentium® M 1.6 GHz		
Internal hard disk		≥ 80 GB IDE, 2.5"	–	
Flash Disk		–	≥ 15 GB	
RAM	With Windows XP® Pro	MB	512 to 2 GB SDRAM	
Memory slot			2 slots	
DVD-ROM drive (reader/writer)		Yes		
Floppy disk drive		3.5", 1.44 MB		
Expansion slots	PCMCIA cards	2 slots (taking a maximum of 1 x type III card or 2 x type I cards)		
	PCI port	1 PCI bus slot		
Built-in I/O ports	Ethernet TCP/IP port	2 RJ45 ports, links: 1 x 10/100/1000BASE-T 1 x 10/100BASE-T		
	USB ports	4 USB 2.0 ports		
	Serial port COM1	1 RS 232C link (9-pin male SUB-D connector)		
	Serial port COM2	1 RS 232C link (9-pin male SUB-D connector)		
	Serial port COM3	1 RS 232C link (9-pin male SUB-D connector)		
	Serial port COM4	1 RS 232C link (9-pin male SUB-D connector)		
	Audio	1 line out 1 line in 1 mic in		
	Operating system		Windows XP® Pro	Windows XP Pro and Vijeo Designer™ RT
	Power supply	Voltage	~ 24 V ~ 100 to 240 V (voltage limits 85 to 265 V), conforming to EN 61131-2	~ 100 to 240 V (voltage limits 85 to 265 V), conforming to EN 61131-2
		Frequency	Hz	50/60 (frequency limits 47/63), conforming to EN 61131-2
Micro-breaks		ms	20	
Consumption		VA	150 max.	
Material		Treated steel		
Mounting		On panel or enclosure door (8 fixing bolts included)		
Environment	Certifications	UL 508, UL 1604, (Haz Loc Class 1 Div 2), cULus, CSA, IEC 61131-2		
	Immunity to interference	High frequency interference, conforming to IEC 61131-2, EN 61000-6-2, FCC (Class A) Electromagnetic emissions, EN 55011 (Group 1, Class A), EN 61000-3-2, EN 61000-3-3		
	Temperature	Operation	°C + 5 to + 50 (+ 5...+ 45 when writing DVD)	
		Storage	°C - 20 to + 60	
	Relative humidity	%	10 to 85	
	Operating altitude	m	0 to 3000 max.	
	Storage altitude	m	0 to 12 000 max.	
	Vibration resistance	m/s ²	9.8 at 10 to 25 Hz/3 axes for 30 minutes	

References

Compact iPC industrial PCs

Magelis® Compact iPCs are “rugged” industrial PCs suited to industrial environments. They are compact, have a wide performance range and are open to Windows XP® Pro applications.

Powered by an ~ 100 to 240 V or ~ 24 V supply, they are fitted with an 8.4", 12" or 15" active matrix back-lit color TFT LCD touch screen. There is a USB port on the front panel (except 8.4") in addition to the standard USB ports, a hard disk ≥ 80 GB or ≥ 160 GB or a Flash Disk ≥ 15 GB, as well as a slot for a PCI card and at least 1 slot for a PCMCIA card.

Compact iPC - Hardware

- The 8.4" models **MPC KT1 2●AX 00●** (Intel® Celeron® M 1 GHz processor) feature two Ethernet ports: 1 x 10/100BASE-T and 1 x 10/100/1000BASE-T (RJ45 connectors). They also have a total of 4 USB ports.

- The 12" models **MPC KT2 2●AX 20N●** (Intel Celeron M 1.5 GHz processor) feature two Ethernet ports: 1 x 10/100BASE-T and 1 x 10/100/1000BASE-T (RJ45 connectors). They also have a total of 5 USB ports, 1 of which is on the front panel. The disk is replaceable by the user.

- The 15" models **MPC KT5 5●●X 20●** (Intel Pentium M 1.6 GHz processor) feature two Ethernet ports: 1 x 10/100BASE-T and 1 x 10/100/1000BASE-T (RJ45 connectors). They also have a total of 5 USB ports, 1 of which is on the front panel.

Compact iPC - Software package

Magelis® Compact iPC hardware is also available in “package” form, which includes either **Vijeo Designer™ RT** or **Vijeo® Citect®** application software.

 The use of Vijeo Designer on Magelis Compact iPC industrial PCs requires HMI Edition-Vijeo Designer RT version for **MPC KT1 2N●X 00H** (8.4") (1) or **MPC KT5 5N●X 20H** (15") or activation of a Vijeo Designer license (ref. **VJDSNRTMPC**) for the **MPC KT2 2N●X 20N** (12").

The Vijeo Citect edition of the Magelis iPC complies with the general sales policy for this software. It is comprised of the DVD with the software and documentation, the USB key with the user rights already registered and one year technical support. The software can be used immediately. Updates and license upgrades are available by providing the key number and are subject to the usual conditions.

This type of offer enables users to acquire, at an attractive price, a pre-installed and tested industrial-grade system, which is correctly dimensioned to suit software application requirements. It is supported across the entire Schneider Electric sales network.

Vijeo Designer™ Runtime for iPC

Magelis® iPC products have traditionally been sold with the choice of units with or without Vijeo Runtime installed. Vijeo Designer Runtime for Magelis iPC products can be purchased and installed separately using part number **VJDSNRTMPC**. Beginning in mid-2010 iPC part numbers for units including the runtime pre installed will be phased out. It will no longer be necessary to order specific products with runtime already installed.

(1) HMI Runtime Editions will soon be replaced by the client edition + VJDSNRTMPC.
For example, MPCST52NAJ20H will become MPCST52NAJ20T + VJDSNRTMPC.

Industrial PCs

Magelis® Compact iPC PC Panels

2



MPC KT1 2NAX 00N

General Purpose Compact iPC with 8.4" screen					
With hard disk					
Processor Supply voltage	RAM	Expansion slots available	Edition	Reference	Weight kg
Celeron® M 1 GHz ~ 100 to 240 V	512 MB expandable to 1024 MB	1 PCI	Client Edition	MPC KT1 2NAX 00N	4.500
			HMI Edition, Vijeo Designer™ RT	MPC KT1 2NAX 00H	4.500



MPC KT2 1NAX 00N

General Purpose Compact iPC with 12" screen					
With hard disk					
Processor Supply voltage	RAM	Expansion slots available	Edition	Reference	Weight kg
Celeron M 1.5 GHz ~ 100 to 240 V	512 MB expandable to 1024 MB	1 PCI 1 x type II PCMCIA	Client Edition	MPC KT2 2NAX 20N (1)	4.500
With 15 GB Flash Disk					
Celeron M 1.5 GHz ~ 100 to 240 V	512 MB expandable to 1024 MB	1 PCI 1 x type II PCMCIA	Client Edition	MPC KT2 2MAX 20N (1)	4.500



MPC KT5 5NAX 20N

General Purpose Compact iPC with 15" screen					
With hard disk					
Processor Supply voltage	RAM	Expansion slots available	Edition	Reference	Weight kg
Pentium® M 1.6 GHz ~ 100 to 240 V	512 MB expandable to 2 GB	1 PCI 1 x type III or 2 x type I PCMCIA	Client Edition	MPC KT5 5NAX 20N	4.500
			HMI Edition, Vijeo Designer RT	MPC KT5 5NAX 20H	4.500
24 V	512 MB expandable to 2 GB	1 PCI 1 x type III or 2 x type I PCMCIA	Client Edition	MPC KT5 5NDX 20N	4.500
			HMI Edition, Vijeo Designer RT	MPC KT5 5NDX 20H	4.500

Heavy Duty Compact iPC with 15" screen					
With Flash Disk (15 GB min.)					
Processor Supply voltage	RAM	Expansion slots available	Edition	Reference	Weight kg
Pentium M 1.6 GHz ~ 100 to 240 V	512 MB expandable to 2 GB	1 PCI 1 x type III or 2 x type I PCMCIA	Client Edition	MPC KT5 5MAX 20N	4.500
			HMI Edition, Vijeo Designer RT	MPC KT5 5MAX 20H	4.500
			Vijeo® Citect® Light 1200 I/O	MPC KT5 5MAX 20L	4.500
			Vijeo® Citect® Full 500 I/O	MPC KT5 5MAX 20V	4.500

(1) HMI Edition with license VJDSNRTMPC (sold separately).

Separate components for Compact iPC				
Description	Details	Compatible with (1)	Reference	Weight kg
RAM expansion	512 MB	8.4" models, Celeron® M MPC KT1 2NAX 00●	MPC YK0 5RAM 512	—
		12" models, Celeron M MPC KT2 2●AX 00●	MPC YK0 5RAM 512	—
		15" models, Pentium® M MPC KT5 5●AX 20●	MPC YK0 5RAM 512	—
	1024 MB	8.4" models, Celeron M MPC KT1 2NAX 00●	MPC YK2 2RA1 024	—
		12" models, Celeron M MPC KT2 2●AX 00●	MPC YK2 2RA1 024	—
		15" models, Pentium M MPC KT5 5●AX 20●	MPC YK2 2RA1 024	—
Hard disk	160 GB	12" Compact iPC MPC YNK2 MSD 20N	MPC YNK2 SHD 20N	—
Flash disk	≥ 15 GB	12" Compact iPC MPC KT2 2MAX 20N	MPC YNK2 MSD 20N	—
Replacement power supply connector	AC connector	All Compact iPCs with AC power supply MPC KT●●●AX ●0●	MPC YN0 0PWA CTE	—
Maintenance kits	Includes panel mounting fixings and seals	8.4" models MPC KT1 2NAX 00●	MPC YK1 0MNT KIT	—
		12" models MPC KT2 2●AX 00●	MPC YK2 0MNT KIT	—
		15" models MPC KT5 5●AX 20●	MPC YK5 0MNT KIT	—
Screen protection	Protective film for Compact iPC	8.4" models MPC KT1 2NAX 00●	MPC YK1 0SPS KIT	—
		12" models MPC KT2 2NAX 00●	MPC YK2 0SPS KIT	—
		15" models MPC KT5 5NAX 20●	MPC YK5 0SPS KIT	—

(1) And software package variants when available.

Dimensions

MPC KT1 2●AX 00●/MPC KT2 2●AX 00●/MPC KT5 5●●X 20●

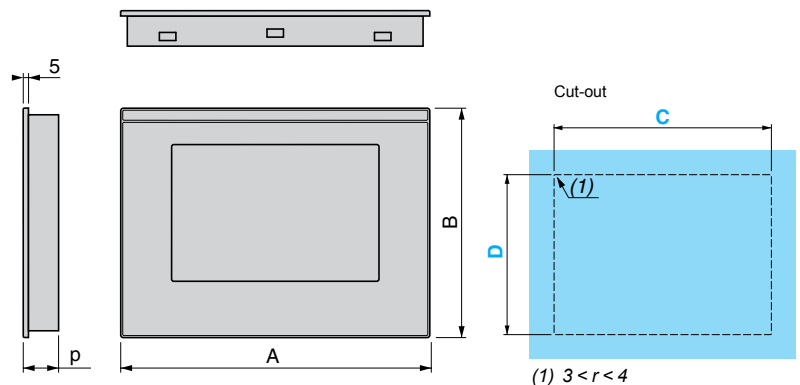

	A	B	C	D	p
MPC KT1 2●AX 00●	230	177	218.5 ⁺¹ ₀	165.5 ⁺¹ ₀	120
MPC KT2 2●AX 00●	313	239	301.5 ⁺¹ ₀	227.5 ⁺¹ ₀	103.0
MPC KT5 5●●X 20●	395	294	383.5 ⁺¹ ₀	282.5	103.0

Industrial PCs

Magelis® Smart Embedded Panels

Equivalent product tables

2

Magelis® Smart 12" equivalent product table		
Type	Old range	New range
Client Edition	MPC ST2 1NAJ 10T	MPC 21 NAJ 20T
HMI Edition	MPC ST2 1NAJ 10R	MPC ST2 1NAJ 20T + license VJD SNRTPMV●●M

Magelis® Smart 15" equivalent product table		
Type	Old range	New range
Client Edition	MPC ST5 2NDJ 00T	MPC ST5 2NDJ 20T
Web Client Edition	MPC ST5 2NDJ 10T	MPC ST5 2NDJ 20T
HMI Edition	MPC ST5 2NDJ 10R	XBT GTW 750

Industrial PCs

Magelis® Compact iPC PC Panels

Equivalent product tables

Magelis® Compact iPC 12" equivalent product table		
Type	Old range	New range (1)
600 MHz - Windows® 2000	MPC KT2 2NAA 00N	MPC KT2 2NAX 20N
600 MHz - Windows XP® Pro	MPC KT2 2NAX 00N	MPC KT2 2NAX 20N
600 MHz, Windows XP Pro and Vijeo Designer RT	MPC KT2 2NAX 00R	MPC KT2 2NAX 20N plus Vijeo Designer™ Run Time license VJD SNR TMPV ●●M

Magelis® Compact iPC 15" equivalent product table		
Type	Old range	New range (1)
667 MHz - Windows 2000	MPC KT5 2NAA 00N	MPC KT5 5NAX 20N
667 MHz - Windows XP Pro	MPC KT5 2NAX 00N	MPC KT5 5NAX 20N
1.7 GHz - Windows 2000	MPC KT5 5NAA 00N	MPC KT5 5NAX 20N
1.7 GHz - Windows XP Pro	MPC KT5 5NAX 00N	MPC KT5 5NAX 20N
667 MHz VL RT - Windows 2000 and Vijeo Look™ RT 1024	MPC KT5 2NAA 00A	MPC KT5 5NAX 20N + VJL SMD RTL V26M
1.7 GHz VL RT - Windows 2000 and Vijeo Look RT 1024	MPC KT5 5NAA 00A	MPC KT5 5NAX 20N + VJL SMD RTL V26M
1.7 GHz VL BT - Windows 2000 and Vijeo Look BT 1024	MPC KT5 5NAA 00B	MPC KT5 5NAX 20N + VJL SMD BTL V26M
667 MHz VL RT - Windows XP Pro and Vijeo Look RT 1024	MPC KT5 2NAX 00A	MPC KT5 5NAX 20N + VJL SMD BTL V26M
1.7 GHz VL RT - Windows XP Pro and Vijeo Look RT 1024	MPC KT5 5NAX 00A	MPC KT5 5NAX 20N + VJL SMD RTL V26M
1.7 GHz VL BT - Windows XP Pro and Vijeo Look BT 1024	MPC KT5 5NAX 00B	MPC KT5 5NAX 20N + VJL SMD BTL V26M
667 MHz VD RT - Windows XP Pro and Vijeo Designer™ RT	MPC KT5 2NAX 00R	MPC KT5 5NAX 20H
1.7 GHz VD RT - Windows XP Pro and Vijeo Designer RT	MPC KT5 5NAX 00R	MPC KT5 5NAX 20H

(1) Windows XP Pro pre-installed.

Application

Embedded Boxes



Model

Smart BOX	Compact PC BOX
-----------	----------------

Compatible screen

iDisplay

CPU	Processor
	Storage
	RAM
	DVD-ROM drive
	Expansion slots
	Ethernet TCP/IP network
	I/O ports
	Operating system

Intel® Celeron® M 600 MHz	Intel Celeron M 1GHz
1 GB minimum Compact Flash, expandable to 4 GB	Hard disk ≥ 80 GB
256 MB minimum, expandable to 1024 MB	512 MB, expandable to 1024 MB
–	–
–	1 PCI bus slot
2 RJ45 ports: 1 x 10/100/1000BASE-T and 1 x 10/100BASE-T	
4 x USB 2.0, 2 x RS432, 1 x VGA RGB video port	
Windows XP® Embedded SP2 (6 languages)	Windows XP® Pro pre-installed

General Purpose (Hard Disk)	Base (Windows XP)	~ 100...240 V
	HMI edition, Vijeo Designer™ Run Time	~ 100...240 V
Heavy Duty (Compact Flash)	Client Edition	~ 100...240 V
		--- 24 V
	HMI Edition, Vijeo Designer Run Time	~ 100...240 V
		--- 24 V

	MPC KN0 2NAX 00N
	MPC KN0 2NAX 00H
MPC SN0 1NAJ 00T	
MPC SN0 1NDJ 00T	
MPC SN0 1NAJ 00H	
MPC SN0 1NAJ 00H	

Pages

2/39	2/40
------	------

Applications

Flex PC BOX



Model

Flex PC BOX F **Flex PC BOX H**

Compatible screen

Front Panel, iDisplay

CPU	Processor	
	Storage	
	RAM	
	DVD-ROM drive	
	Expansion slots	
	Ethernet TCP/IP network	
	I/O ports	
	Operating system	

Intel® Celeron® M 1.86 GHz or Core Duo 2 GHz	
1 or 2 hard disks ≥ 160 GB, Flash Disk ≥ 15 GB	
512 MB expandable to 2 GB	
Yes, DVD reader, DVD reader/writer available as option.	
2 PCI bus slots	4 PCI bus slots
2 RJ45 ports: 1 x 10/100/1000BASE-T and 1 x 10/100BASE-T	
4 x USB 2.0, 4 x RS432, 1 x DIO 1 x DVI-I video port (RGB support)	
Windows XP® Pro pre-installed	

General Purpose (Hard Disk)	Base (Windows XP)	~ 100...240 V
		--- 24 V
Heavy Duty (Flash Disk)	Base (Windows XP)	~ 100...240 V
	HMI edition, Vijeo Designer™ Run Time	~ 100...240 V
	Vijeo® Citect® Edition	~ 100...240 V

MPC FN0 0NAX 00N	MPC HN0 0N0X 00N
MPC FN0 0NDX 00N	MPC HN0 5NDX 00N
MPC FN0 5MAX 00N	MPC HN0 5MAX 00N
MPC FN0 5MAX 00H	MPC HN0 5MAX 00H
MPC FN0 5MAX 00V	MPC HN0 5MAX 00V

Pages

2/41 2/42

Applications

Screens for Flex PC BOX



Model

Front Panel

12" screen TFT (800 x 600)	Data entry via keyboard and touch screen
15" screen TFT (1024 x 768)	Data entry via touch screen
	Data entry via keyboard and touch screen
19" screen TFT (1280 x 1024)	Data entry via touch screen

MPC YB2 0NNN 00N		
	MPC YT5 0NNN 00N	
		MPC YB5 0NNN 00N
		MPC YT9 0NNN 00N

Pages

2/43

Industrial PCs

Magelis® Smart BOX, Magelis® Compact PC BOX, Magelis® Flex PC BOX and Front Panels

2



Magelis® Flex PC BOX H and 19" Front Panel



Magelis® Flex PC BOX F and 15" Front Panel



Magelis® Compact PC BOX



Magelis® Smart BOX

Introduction

For situations where the HMI needs to be separated from a CPU operating in a Windows® environment, Magelis® BOX industrial PCs offer a variety of solutions with graded power ratings, designed to meet the HMI and SCADA requirements for both process applications and machines:

- Connection to standard PC hardware:
 - Network: two Ethernet ports (10/100/1G and 10/100).
 - USB: four USB ports for storage, WiFi connection, etc.
 - Printers: numerous printers are supported.
- Applications processed in the Microsoft® Windows® environment:
 - SCADA,
 - Use of multimedia data: audio, images, video,
 - Support for all types of Office® files: Microsoft® Word, Excel®, PowerPoint®, etc.
 - Third-party software run in Windows.
- Integration in distributed architectures:
 - Client/server architecture
 - Access to Intranet/Internet network.

The Magelis BOX range consists of four CPUs and two screen families:

- **Embedded BOX Smart BOX**, with Intel® Celeron® M 600 MHz processor, data storage on 1 GB Compact Flash card, 256 MB of memory, expandable to 1024 MB.
- **Compact PC BOX**, with Intel Celeron M 1 GHz processor, data storage on hard disk \geq 80 GB, 512 MB memory, expandable to 1024 MB; expansion slot available for PCI card.
- **Flex PC BOX F**, with Intel Celeron M 1.86 GHz or Core Duo 2 GHz processor, data storage on one or two hard disks \geq 80 GB, 16 GB Flash Disk, 512 MB memory, expandable to 2 GB; two expansion slots for PCI card.
- **Flex PC BOX H**. As Flex PC BOX F, but with four expansion slots for PCI card.

Compatible flat screens:

- **Magelis® iDisplay (industrial display)** in two sizes:
 - 15" with touch screen, with or without keyboard,
 - 19" with touch screen.
 Smart BOX and Compact PC BOX CPUs are only compatible with the Magelis iDisplay.
- **Magelis® iPC front panel** (for Flex PC BOX CPUs only) in 3 sizes:
 - 12" with touch screen and keyboard,
 - 15" with touch screen, with or without keyboard,
 - 19" with touch screen.
- Magelis Flex PC BOX F and Magelis Flex PC BOX H CPUs can be connected to a Magelis iPC Front Panel. Depending on the requirements of the application, they may also be connected to a second Magelis iDisplay interface.

Introduction (continued)**General Purpose and Heavy Duty versions**

Embedded BOX and PC BOX CPUs are available in three versions (1): General Purpose, Heavy Duty and Optimized.

■ **General Purpose:** Version for "standard" industrial environments, ambient temperatures generally ranging between 5 °C and 35 °C, and moderate shock and vibration conditions. General Purpose models feature industrial hard disks:

- Magelis® Compact PC BOX: 80 GB minimum hard disk
- Magelis® Flex PC BOX F/H: 160 GB minimum hard disk

■ **Heavy Duty:** "Rugged" versions of industrial PCs, designed to operate in environments where harsher conditions prevail in terms of both temperature (between 0 °C and 50 °C) and vibrations, due to their storage media:

- Magelis Flex PC BOX F/H: 15 GB minimum hard disk

■ **Optimized:** Versions of industrial PCs that are completely solid-state (not a single moving part is used). They are designed to operate in harsh environments (0 °C to 50 °C) and require no maintenance. These PCs use Windows XP® Embedded operating systems and a Compact Flash card for storage purposes:

- Embedded Box Smart BOX: 1 GB Compact Flash minimum, expandable to 4 GB.

Integrated diagnostics

Diagnostic functions, specifically designed to simplify maintenance work, are integral features of the Smart BOX, Compact PC BOX and Flex PC BOX F/H CPUs. They include:

■ Monitoring of the internal temperature of the CPU, with information provided as follows if set values are exceeded:

- the display of an on-screen message,
- a change in state on a DIO output,
- the starting-up of a system task, for example: sending an e-mail,
- log: in the Windows Event Manager.

■ Monitoring of the integrity of the hard disk on every startup.

The Magelis® Flex PC BOX F/H CPUs have an integrated RAS interface (2) comprised of:

- 1 alarm output
- 1 reset input
- 1 general purpose input
- 1 general purpose output

Combined HMI Edition and Vijeo® Citect® Edition offers

The combined HMI Edition offers feature the Smart BOX, Compact PC BOX and Flex PC BOX F/H CPUs, along with Vijeo Designer™ Run Time software.

The combined Vijeo® Citect® Edition offers feature the Flex PC BOX F/H CPUs, along with Vijeo Citect Full 500 I/O software.

The Vijeo Citect edition of the Magelis iPC complies with the general sales policy for this software. It is comprised of the DVD with the software and documentation, the USB key with the user rights already registered, and one year technical support. The software can be used immediately. Updates and license upgrades are available by providing the key number and subject to the usual conditions.

This type of offer enables users to acquire, at an attractive price, a pre-installed and tested industrial-grade system, which is correctly dimensioned to suit software application requirements, and is supported across the entire Schneider Electric sales network.

(1) Excluding Embedded Box Smart BOX, which is available in Optimized version only.

(2) RAS: reliability, availability, serviceability.



Magelis® Smart BOX: MPC SN0 1N●J 00●

Magelis® Smart BOX CPUs

Introduction

Magelis® Smart BOX CPUs are designed to operate in harsh industrial environments and offer state-of-the-art technology.

Four Magelis Smart BOX **MPC SN0 1N●J 00●** CPU models are available. Key characteristics are:

- *Optimized* type with 1 GB Compact Flash mass memory
- Celeron® M 600 MHz processor
- Windows XP® Embedded SP2 operating system pre-installed on all *Client Edition MPC SN0 1N●J 00T* and *HMI Edition MPC SN0 1N●J 00H* models.

The CPUs differ in respect to the following functions and characteristics:

- Vijeo Designer™ Run Time pre-installed on *HMI Edition MPC SN0 1N●J 00H* models.
- ~ 100 - 240 V power supply for Magelis Smart BOX **MPC SN0 1NAJ 00●** models, external AC/DC adaptor included with product.
- 24 V power supply for **MPC SN0 1NDJ 00●** models.

Description

Magelis® Smart BOX CPUs feature the following elements:

- 1 Slot for 1 GB primary (system) Compact Flash card.
- 2 Slot for secondary Compact Flash card.
- 3 1 Ethernet 10/100 Base-T port and 1 Ethernet 10/100/1000 Base-T port.
- 4 4 USB ports.
- 5 RGB video port: connector for external screen, zDisplay for example.
- 6 Audio output for loudspeaker.
- 7 Connectors for COM1 and COM2 ports.
- 8 Status and power supply LED.
- 9 Disk access LED.
- 10 Power supply connector.
- 11 Attachment point for USB holder.
- 12 Reset switch.

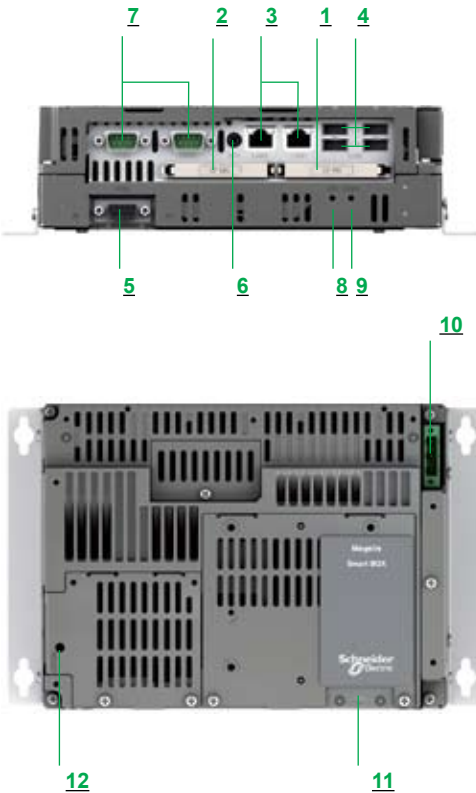

Specifications of Magelis® Smart BOX CPUs

Type		Heavy Duty Magelis® Smart BOX MPC SN0 1N0J 000
Processor		Intel® Celeron® M 600 MHz
Storage		1 GB Compact Flash, expandable to 4 GB
RAM		256 MB SDRAM, expandable to 1024 MB
Built-in I/O ports	Ethernet ports	1 Ethernet TCP/IP 10/100BASE-T link (RJ45 connector) 1 Ethernet TCP/IP 10/100/1000 BASE-T link (RJ45 connector)
	USB	4 USB 2.0 links
	Serial links	2: COM1, COM2, RS 232 type (9-pin male SUB-D connector)
	Video	1 connection for external RGB video screen
	Audio	1 audio output for loudspeakers (mini-jack connector)
Operating system		Windows XP® Embedded, 6 languages depending on Edition. <input type="checkbox"/> HMI Edition: English, French, German, Italian, Spanish and Chinese (simplified). <input type="checkbox"/> Client Edition: English, French, German, Italian, Spanish and Swedish.
Compatible screen from the Magelis offer		iDisplay
Power supply	AC	
	Voltages	~ 100...240 V (voltage limits 98...264 V), conforming to EN 61131-2
	Frequency	50/60 Hz (frequency limits 47/63 Hz), conforming to EN 61131-2
	Micro-breaks	10 ms
	DC	
Voltages	≐ 24 V (voltage limits 23...25 V)	
Micro-breaks	1 ms max.	
Consumption	AC	130 VA
	DC	40 W max.
Material		Nickel plated steel
Mounting		Horizontal or on wall (in enclosure). Supplied with set of 2 fixings for mounting

Environmental characteristics of Magelis® Smart BOX CPUs

Type		MPC SN0 1N0J 000
Degree of protection		IP 20 Standards: IEC/EN 60529, NEMA 250, EN 61131-2
Pollution level		Designed for use in environments with pollution level 2
Temperature	In operation	0 to 50 °C, conforming to EN 61131-2, UL 1604
	For storage	- 20 to 60 °C, conforming to IEC 60068-2-2 tests Bb and Ab, IEC 60068-2-14 test Na and EN 61131-2
Operating altitude		0...2000 m. Standard EN 61131-2
Vibration resistance	In operation	0.075 mm amplitude from 10 to 57.6 Hz 1 g amplitude from 57.6 to 150 Hz Standard EN 61131-2
	Out of service (in storage)	3.5 mm amplitude from 5 to 9 Hz 1 g amplitude from 9 to 150 Hz Standard EN 61131-2
Shock resistance	In operation	15 g peak for 11 ms. Standard IEC 60068-2-27 test Ea and EN 61131-2
Humidity		10 to 90% RH - wet-bulb temperature: 29 °C max. - without condensation
Immunity to interference	High frequency interference	Conforming to EN 61131-2, IEC 61000-4-3/6 level 3
	Electromagnetic waves	Class A/EN 55022/55011
Certifications	Information Technology Equipment	IEC/EN 60950 C-Tick, N998
	Industrial Control Equipment	UL 508, CSA 22.2, n° 142
	ATEX	II 3 Gas and dust (zone 2/22)



Magelis® Compact PC BOX: MPC KN0 2NAX 00N

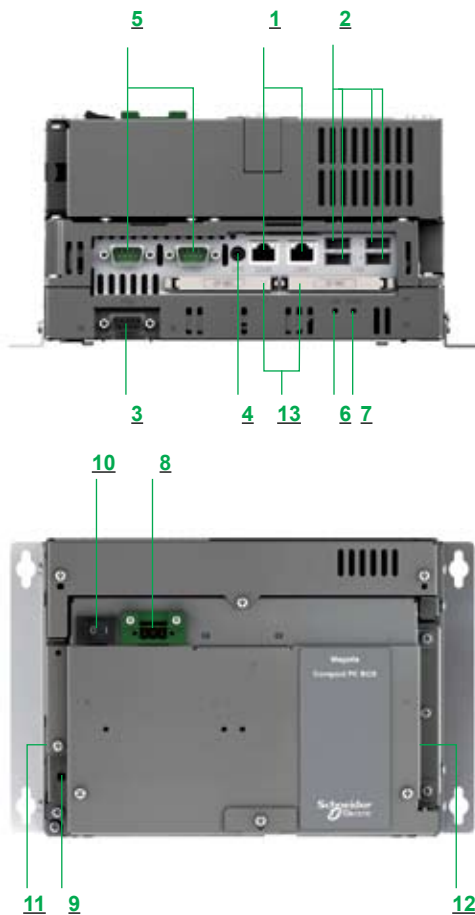

Magelis® Compact PC BOX CPUs

Introduction

Magelis® Compact PC BOX CPUs are designed to operate in either standard industrial or harsh industrial environments and offer state-of-the-art technology.

The main characteristics of the Compact PC BOX **MPC KN0 2NAX 00N** CPUs are:

- Celeron® M 1 GHz processor.
- PCI card expansion: 1 slot.
- ~ 100-240 V power supply.
- Windows XP® Pro SP2 operating system pre-installed.
- Hard disk mass memory ≥ 80 GB..

Description

Magelis® Compact PC BOX CPUs feature the following elements:

- 1 1 Ethernet 10/100 Base-T port and 1 Ethernet 10/100/1000 Base-T port.
- 2 4 USB ports.
- 3 RGB video port: connector for external iDisplay screen.
- 4 Audio output for loudspeaker.
- 5 Connectors for COM1 and COM2 ports.
- 6 Status and power supply LED.
- 7 Disk access LED.
- 8 Power supply connector.
- 9 Reset switch.
- 10 On/Off switch.
- 11 Cooling fan.
- 12 PCI expansion unit interface.
- 13 Slots for 2 Compact Flash cards.

Specifications of Magelis® Compact PC BOX CPUs

Type		General Purpose Magelis® Compact PC BOX MPC KN0 2NAX 00N Hard disk
Processor		Intel® Celeron® M 1 GHz
Storage		Hard disk ≥ 80 GB
RAM		512 MB SDRAM, expandable to 1024 MB
Slots for Compact Flash cards		2
Expansion slots		1 PCI 2.2 bus slot
Built-in I/O ports	Ethernet ports	1 Ethernet TCP/IP 10/100BASE-T link (RJ45 connector) 1 Ethernet TCP/IP 10/100/1000 BASE-T link (RJ45 connector)
	USB	4 USB 2.0 links (at rear)
	Serial links	2: COM1, COM2, RS 232 type (9-pin male SUB-D connector)
	Video	1 connection for external RGB video screen
	Audio	1 audio output for loudspeakers (mini-jack connector)
Floppy disk drive		1
Operating system		Windows XP® Pro SP2 pre-installed
Compatible screens from the Magelis® offer		iDisplay
Power supply	AC	
	Voltages	~ 100...240 V (voltage limits 85...265 V)
	Frequency	50/60 Hz (frequency limits 47/63 Hz), conforming to EN 61131-2
	Micro-breaks	20 ms max.
	Isolation	~ 1500 V, 20 mA for 1 minute
Consumption		120 VA
PCI expansion	Capacity	□ --- 5 V, 1.5 A □ --- 12 V, 0.5 A □ --- 12 V, 0.1 A □ --- 3.3 V, 0.5 A
	Consumption	10.9 W between 5 °C and 45 °C (ambient air temperature) Linear decrease to 7.6 W between 45 °C and 50 °C
Material		Nickel plated steel
Mounting		In enclosure, horizontally or on wall. Supplied with set of 2 fixings.

Environmental characteristics of Magelis® Compact PC BOX CPUs

Type		MPC KN0 2NAX 00N
Degree of protection		IP 20 Standards: IEC/EN 60529, NEMA 250, EN 61131-2
Pollution level		Designed for use in environments with pollution level 2
Temperature	In operation	5 to 50 °C, conforming to EN 61131-2, UL 1604
	Storage	- 20 to 60 °C, conforming to IEC 60068-2-2 tests Bb and Ab, IEC 60068-2-14 test Na and EN 61131-2
Operating altitude		0...2000 m. Standard EN 61131-2
Vibration resistance	In operation	75 mm amplitude from 10 to 57.6 Hz 1 g amplitude from 57.6 to 150 Hz Standard EN 61131-2
	Out of service (in storage)	3.5 mm amplitude from 5 to 9 Hz 1 g amplitude from 9 to 150 Hz Standard EN 61131-2
Shock resistance	In operation	15 g peak for 11 ms. Standard IEC 60068-2-27 test Ea and EN 61131-2
Humidity		10 to 85% RH - wet-bulb temperature: 29 °C max. - without condensation
Immunity to interference	High frequency interference	Conforming to EN 61131-2, IEC 61000-4-3/6 level 3
	Electromagnetic waves	Class A/EN 55022/55011
Certifications	Information Technology Equipment	IEC/EN 60950 C-Tick, N998
	Industrial Control Equipment	UL 508, CSA 22.2, n° 142



Magelis® Flex PC BOX F: MPC FN0 ●●●X 00●



Magelis® Flex PC BOX H: MPC HN0 ●●●X 00●

Magelis® Flex PC BOX CPUs

Introduction

Magelis® Flex PC BOX high-end CPUs are designed to respond to the most rigorous, demanding industrial applications requiring optimum processor power and PCI card expansion.

Magelis Flex PC BOX F: **MPC FN0 ●●●X 00●**, with 2 PCI card slots

Magelis Flex PC BOX H: **MPC HN0 ●●●X 00●**, with 4 PCI card slots.

Two Magelis® Flex PC BOX families are available. A General Purpose version for standard industrial environments, and a Heavy Duty version for industrial environments where harsher conditions prevail.

■ **General Purpose** with hard disk ≥ 160 GB, two processor levels and basic RAM that can be expanded to 2 GB.

□ Intel® Celeron® M 1.86 GHz processor, standard memory: 512 MB

□ Core Duo M 2 GHz processor, standard memory: 1024 MB

General Purpose Magelis® Flex PC BOX F/H models are available with a ~ 24 V or ~ 100...240 V power supply, in Base Windows XP® Edition only.

■ **Heavy Duty** with Core Duo M 2 GHz processor, standard RAM: 1024 MB expandable to 2 GB, 16 GB Flash Disk in versions:

□ "HMI Edition", featuring pre-installed Vijeo Designer™ Run Time software.

□ "Vijeo® Citect® Edition" featuring pre-registered Vijeo® Citect® software.

□ "Base Windows XP®".

Heavy Duty Magelis Flex PC BOX F/H CPUs are only available with an ~ 100...240 V power supply.

All Magelis® Flex PC BOX F/H CPUs can be connected either directly or remotely to a Magelis Front Panel type flat screen or remotely to a Magelis iDisplay flat screen, and feature:

□ 2 Ethernet TCP/IP ports with RJ45 connector, one of which is 10/100/1000BASE-T,

□ 4 USB ports (12 Mbps),

□ 4 serial COM ports (RS 232),

□ 1 DVD-ROM drive (reader), with option of replacement by a CD/DVD drive (reader/writer) **MPC YN0 OCDW 30N**.

□ 1 RAS port.

1 DVI-I video port with RGB support, making it possible to connect a Magelis® iDisplay screen in addition to the main Magelis Front Panel, for example.

System Monitor

The System Monitor function featured in Flex PC BOX F/H CPUs enables the monitoring of several parameters or system functions:

- CPU temperature,
- fan speed,
- supply voltages,
- disk,
- back lighting, etc.

System Monitor controls the handy RAS port in order to signal an alarm (by means of a digital output), or to initiate a Flex PC BOX restart. Alerts are also signalled in the form of a pop-up message or a Windows alarm (Event Viewer).

RAID 1 option

The RAID 1 option **MPC YN0 ORAI D0N** (for General Purpose versions only) involves configuring a second disk within the system with a mirror image of the first disk. This increases the system's tolerance to disk errors and enables it to function provided that at least one disk is operational. The defective disk can be replaced without the need to stop the Flex PC BOX. The option includes a disk cartridge with a capacity ≥ 80 GB and RAID software for installation.

Flex PC BOX with Battery Backup

The Flex PC BOX equipped with Battery Backup **MPC HN0 5NBX 00N** (for Flex PC BOX H only) enables the system to continue operating for about 5 minutes (depending on the system load) in the event of a power failure. UL 60950 certification only.

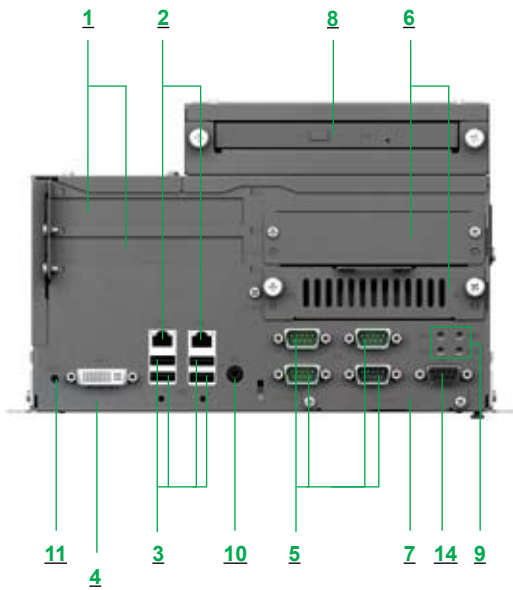

Magelis® Flex PC BOX CPUs

Description

Magelis® Flex PC BOX CPUs feature the following elements:

- 1** PCI expansion slots.
 - Magelis Flex PC BOX F CPUs: 2 PCI cards.
 - Magelis Flex PC BOX H CPUs: 4 PCI cards.
- 2** 1 Ethernet 10/100 Base-T port and 1 Ethernet 10/100/1000 Base-T port.
- 3** 4 USB ports.
- 4** DVI I interface.
- 5** 4 connectors for COM1 to COM4 ports.
- 6** 2 hard disk slots.
- 7** 1 slot for Compact Flash card.
- 8** 1 slot for DVD-ROM drive (reader).
- 9** 4 LEDs:
 - 2 disk status LEDs
 - 1 power supply/RAS access LED
 - 1 disk access LED.
- 10** Audio output for loudspeaker.
- 11** Reset switch.
- 12** Cooling fan.
- 13** Power supply connector and On/Off switch (AC supply models only).
- 14** RAS port.

Note: AC versions have an On/Off switch.



Specifications of Magelis® Flex PC BOX CPUs		
Type	General Purpose Flex PC BOX MPC ●N0 ●N●X 00● Hard disk	Heavy Duty Flex PC BOX MPC ●N0 5●AX 00● Flash disk
Processor	Intel® Celeron® M 1.86 GHz or Core Duo 2 GHz	
Storage	Hard disk ≥ 80 GB, option of adding additional hard disk	Flash disk ≥ 16 GB, option of adding additional Flash disk
RAID function	Option	–
RAM	512 MB SDRAM, expandable to 2 GB	
DVD drive (reader/writer)	Yes	
Video controller	Built-in	–
Video memory	64 MB max.	
Built-in I/O ports	<ul style="list-style-type: none"> - 1 Ethernet TCP/IP 10/100/1000 BASE-T link (RJ45 connector) - 1 Ethernet TCP/IP 10/100BASE-T link (RJ45 connector) - 4 USB ports (12 Mbps) - 4 COM1 to COM4 RS 232 serial links (9-pin male SUB-D connector) - 1 connection for DVI-I external video screen (29-pin connector) 	
RAS interface (1)	On 9-pin female SUB-D connector <ul style="list-style-type: none"> - 1 alarm output - 1 x 2 channel general purpose input - 1 x 2 channel general purpose output - 1 reset input 	
Expansion slots	<ul style="list-style-type: none"> - 2 PCI bus slots for MPC FN0 ●●●X 00● - 4 PCI bus slots for MPC HN0 ●●●X 00● 	
Slot for Flash card memory	1 Compact Flash card reader (type I/II compatible)	
Audio port	Stereo output for loudspeakers (mini-jack stereo)	
Video	DVI-I, 29-pin	
Operating system	Windows XP® Pro SP2 pre-installed	
Compatible screens	<ul style="list-style-type: none"> - Front Panels - iDisplay 	
Power supply	AC	
	Voltage	~ 100...240 V (voltage limits ~ 85 to 265 V)
	Frequency	50/60 Hz (frequency limits 47 to 63 Hz), conforming to EN 61131-2
	Consumption	120 VA max.
	Micro-breaks	20 ms max.
	Isolation	~ 1500 V, 20 mA for 1 minute
	DC	
	Voltage	--- 24 V (voltage limits --- 19.8...28.8 V)
	Consumption	120 W max.
	Micro-breaks	5 ms max.
	Isolation	--- 1000 V, 10 mA for 1 minute
	PCI expansion	
	Capacity	<ul style="list-style-type: none"> □ --- 5 V, 1.5 A □ --- 12 V, 0.5 A □ --- 12 V, 0.1 A □ --- 3.3 V, 0.5 A
	Consumption	10.9 W max. between 5 °C and 45 °C (ambient air temperature) Linear decrease to 7.6 W between 45 °C and 50 °C
Material	Nickel plated steel	
Mounting	In a type 4X or 12 enclosure	
Specifications of Flash disk (Heavy Duty Flex PC BOX only)		
Capacity	16 GB	
Average time between 2 failures at 25 °C	> 4 000 000 hours	
Data integrity	< 1 non-recoverable error per 10 ¹⁴ bits read	

(1) RAS: reliability, availability, serviceability.

Environmental characteristics of Magelis® Flex PC BOX CPUs		
Type	General Purpose Magelis® Flex PC BOX	Heavy Duty Magelis® Flex PC BOX
	Hard disk	Flash disk
Degree of protection	IP 65/NEMA®4x/12 for the screen front panels. IP 20 for screen sides and back panels, and for the control units as a whole. Standards: IEC/EN 60529, NEMA 250, EN 61131-2	
Pollution level	Designed for use in environments with pollution level 2. Standard: IEC/EN 61010-1	
Temperature	For operation	5 to 50 °C, conforming to EN 61131-2, UL 1604 (5...45 °C when writing DVD)
	For storage	- 20 to 60 °C, conforming to IEC/EN 60068-2-2 tests Bb and Ab, IEC/EN 60068-2-14 test Na and EN 61131-2
Operating altitude	0...2000 m. Standard EN 61131-2	
Vibration resistance	In operation	75 mm amplitude from 10 to 57.6 Hz 1 g amplitude from 57.6 to 150 Hz. Standard EN 61131-2
	Out of service (in storage/transport)	3.5 mm amplitude from 10 to 57.6 Hz 1 g amplitude from 57.6 to 150 Hz Standard EN 61131-2
Shock resistance	In operation	15 g for 11 ms. Standard IEC/EN 60068-2-27 test Ea and EN 61131-2
Ambient humidity	In operation	10 to 85% RH - wet-bulb temperature: 29 °C max. - without condensation
Storage humidity		10 to 85% RH - wet-bulb temperature: 29 °C max. - without condensation Conforming to EN 61131-2
Immunity to interference	High frequency interference	Conforming to EN 61131-2, IEC 61000-4-3/6 level 3
	Electromagnetic emissions	Class A/EN 55022/55011
Certifications	Information Technology Equipment	IEC/EN 60950
	Industrial Control Equipment	UL 508/cUL, UL 1604/cUL (HazLoc Class 1 Div 2 cULus)
	ATEX	For the --- 24 V version only, II 3 gas and dust (zone 2/22)

2



MPC YB2 0NNN 00N



MPC NB5 0NAN 00N



MPC YT5 0NNN 00N



MPC YT9 0NNN 00N

Introduction

The Front Panel flat screens are designed for use with Magelis® Flex PC BOX F/H CPUs.

The screens feature TFT LCD technology and are available in 3 sizes:

- 12"
MPC YB2 0NNN 00N with data entry via touch screen and keyboard, SVGA 800 x 600 resolution.
- 15"
MPC NB5 0NAN 00N with data entry via touch screen and keyboard,
MPC YT5 0NNN 00N with data entry via touch screen,
both with XGA 1024 x 768 resolution.
- 19"
MPC YT9 0NNN 00N with data entry via touch screen, SXGA 1280 x 1024 resolution.

All models feature:

- a USB port on the front (with protective cover),
- a pointing device.

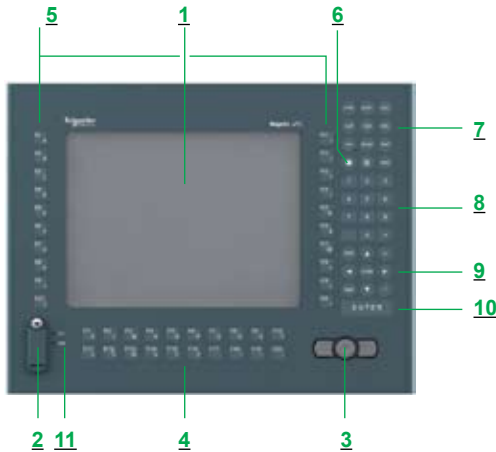

Description

12" and 15" Front Panel with touch screen and keyboard MPC YB2 0NNN 00N/MPC NB5 0NAN 00N

Front Panels **MPC YB2 0NNN 00N/MPC NB5 0NAN 00N** with touch screen and keyboard feature the following:

- 1 An active matrix color TFT LCD screen with high definition analog touch panel:
 - SVGA 800 x 600 for the 12" Front Panel **MPC YB2 0NNN 00N**
 - XGA 1024 x 768 for the 15" Front Panel **MPC NB5 0NAN 00N**
- 2 A USB cover for access to:
 - a type A USB connector.
 - a hardware reset button.
- 3 A mouse button and left/right-click buttons.
- 4 20 function and character keys, F1...F20.
- 5 20 special function and character keys, R1...R20.
- 6 A key for switching between function/alphanumeric mode with an LED to indicate that character entry is active.
- 7 Window navigation keys.
- 8 Numeric keys.
- 9 Cursor keys.
- 10 Enter key.
- 11 Two LEDs:
 - A power supply/RAS access LED
 - An IDE/disk access LED.

On the rear panel:

A connection port for the Magelis® Flex PC BOX.



15" and 19" Front Panel with touch screen MPC YT5/YT9 0NNN 00N

Front Panels **MPC YT5/YT9 0NNN 00N** with touch screen feature the following:

- 1 An active matrix color TFT LCD screen with high definition analog touch panel:
 - XGA 1024 x 768 for the 15" Front Panel **MPC YT5 0NNN 00N**
 - SXGA 1280 x 1024 for the 19" Front Panel **MPC YT9 0NNN 00N**
- 2 A type A USB connector with cover.
- 3 A power supply/RAS access LED.
- 4 A disk access/IDE LED.

On the rear panel:

A connection port for the Magelis® Flex PC BOX.

Specifications of Front Panels						
Type	MPC	YB2 0NNN 20N	YT5 0NNN 00N	YB5 0NAN 00N	YT9 0NNN 00N	
Screen	Type	12" SVGA active matrix color TFT LCD	15" XGA active matrix color TFT LCD		19" SXGA active matrix color TFT LCD	
	Definition	800 x 600	1024 x 768		1280 x 1024	
	Number of colors	262 144				
	Brightness	≥ 200 cd/ma ² , adjustable				
Data entry	Via	Keyboard and touch screen	Touch screen	Keyboard and touch screen	Touch screen	
	Keyboard	Alphanumeric keys	70 standard IBM keys	–	70 standard IBM keys	–
		User function keys	2 x 20 keys	–	2 x 20 keys	–
Touch panel		Analog resistive, resolution: 1024 x 1024				
Front panel	Pointing device	Built-in				
	USB port	1				
Mounting		On any Magelis® Flex PC BOX CPU				
Power supply		From Magelis® Flex PC BOX CPU				



MPC SN0 1N●J 00●

Magelis® Smart BOX CPUs

Magelis® Smart BOX CPUs accept iDisplay flat screens and are equipped with:

- An Intel® Celeron® M 600 MHz processor.
- A 1 GB Compact Flash card.
- 256 MB of RAM as standard, expandable to 1024 GB.
- Two Ethernet TCP/IP ports:
 - 10/100BASE-T, 10/100 Mbps (RJ45 connector)
 - 10/100/1000 BASE-T, 10/100/1000 Mbps (RJ45 connector).
- Four USB ports, 12 Mbps.
- Two serial COM ports (RS 232).
- An RGB video port.
- A pre-installed Windows XP® Embedded SP2 operating system.

Heavy Duty Magelis® Smart BOX

With 1 GB Compact Flash minimum, expandable to 4 GB

Processor Supply voltage	RAM	Expansion slots available	Edition	Reference	Weight kg
Celeron® M 600 MHz ~ 100 to 240 V	256 MB expandable to 1 GB	–	Client Edition	MPC SN0 1NAJ 00T	2.800
			HMI Edition, Vijeo Designer RT	MPC SN0 1NAJ 00H	2.800
Celeron M 600 MHz ≡ 24 V			Client Edition	MPC SN0 1NDJ 00T	2.800
			HMI Edition, Vijeo Designer RT	MPC SN0 1NDJ 00H	2.800

Separate parts for Magelis® Smart BOX

Description	Specifications	Compatible with	Reference	Weight kg
Compact Flash memory card	2 GB, with Windows XP Embedded SP2 software in 6 languages (English, French, German, Italian, Spanish and simplified Chinese) and Framework .NET pre-installed	Smart BOX	MPC YN1 1CF2 10M	2.800



MPC KN0 2NAX 00N

Magelis® Compact PC BOX CPUs

Magelis® Compact PC BOX CPUs accept iDisplay flat screens and are equipped with:

- An Intel® Celeron® M 1 GHz processor.
- A hard disk ≥ 80 GB.
- 512 MB of RAM as standard, expandable to 1024 GB.
- Two Ethernet TCP/IP ports:
 - 10/100BASE-T, 10/100 Mbps (RJ45 connector)
 - 10/100/1000 BASE-T, 10/100/1000 Mbps (RJ45 connector).
- A PCI bus slot.
- Four USB ports, 12 Mbps.
- Two serial COM ports (RS 232).
- An RGB video port.
- A pre-installed Windows XP® Pro SP2 operating system.

General Purpose Compact BOX

With disk drive ≥ 80 GB					
Processor Supply voltage	RAM	Expansion slots available	Edition	Reference	Weight kg
Celeron M 1 GHz ~ 100 to 240 V	512 MB expandable to 1024 MB	1 PCI bus	Client Edition	MPC KN0 2NAX 00N	3.500
			HMI Edition, Vijeo Designer™ RT	MPC KN0 2NAX 00H	3.500



MPC FN0 ●N●X 00N

Magelis® Flex PC BOX CPUs

Magelis® Flex PC BOX CPUs accept iDisplay and Front Panel flat screens. They are equipped with:

- An Intel® Celeron® M 1.86 GHz or Core Duo 2 GHz processor.
- Either one or two hard disks ≥ 80 GB or a 16 GB Flash disk.
- RAM expandable to 2 GB:
 - 512 MB standard memory with Celeron M processor
 - 1024 MB standard memory with Core® Duo® M processor
- DVD-ROM drive (reader)
- Two Ethernet TCP/IP ports:
 - 10/100BASE-T, 10/100 Mbps (RJ45 connector)
 - 10/100/1000 BASE-T, 10/100/1000 Mbps (RJ45 connector).
- Two or four PCI bus slots.
- Four USB ports, 12 Mbps.
- Four serial COM ports (RS 232).
- One DIO
- A DVI-I video port with RGB support.
- A pre-installed Windows XP® Pro operating system.

General Purpose Magelis® Flex PC BOX F

With hard disk ≥ 160 GB

Processor Supply voltage	RAM	Expansion slots available	Edition	Reference	Weight kg
Celeron M 1.86 GHz ~ 100 to 240 V	512 MB expandable to 2 GB	2 PCI bus	Base Windows XP	MPC FN0 2NAX 00N	6.000
Celeron M 1.86 GHz ~ 24 V				MPC FN0 2NDX 00N	6.000
Core Duo 2 GHz ~ 100 to 240 V	1024 MB expandable to 2 GB			MPC FN0 5NAX 00N	6.000
Core Duo 2 GHz ~ 24 V				MPC FN0 5NDX 00N	6.000

Heavy Duty Magelis® Flex PC BOX F

With Flash Disk ≥ 15 GB

Processor Supply voltage	RAM	Expansion slots available	Edition	Reference	Weight kg
Core Duo 2 GHz ~ 100 to 240 V	1024 MB expandable to 2 GB	2 PCI bus	Base Windows XP	MPC FN0 5MAX 00N	6.000
Core Duo 2 GHz ~ 100 to 240 V	1024 MB expandable to 2 GB	2 PCI bus	HMI Edition, Vijeo Designer™ RT	MPC FN0 5MAX 00H	6.000
			Vijeo® Citect® Edition Full 500 I/O	MPC FN0 5MAX 00V	6.000



MPC HN0 N0X 00N

2

General Purpose Magelis® Flex PC BOX H					
General Purpose with hard disk ≥ 160 GB					
Processor	RAM	Expansion slots available	Edition	Reference	Weight kg
Celeron® M 1.86 GHz ~ 100 to 240 V	512 MB expandable to 2 GB	4 PCI bus	Base Windows XP®	MPC HN0 2NAX 00N	7.500
Core Duo 2 GHz ~ 100 to 240 V	1024 MB expandable to 2 GB			MPC HN0 5NAX 00N	7.500
Core Duo 2 GHz ~ 100 to 240 V with backup battery				MPC HN0 5NBX 00N (1)	7.500
Core Duo 2 GHz ~ 24 V				MPC HN0 5NDX 00N	7.500

Heavy Duty Magelis® Flex PC BOX H					
With Flash Disk ≥ 15 GB					
Processor	RAM	Expansion slots available	Edition	Reference	Weight kg
Core Duo 2 GHz ~ 100 to 240 V	1024 MB expandable to 2 GB	4 PCI bus	Base Windows XP	MPC HN0 5MAX 00N	7.500
			HMI Edition, Vijeo Designer™ RT	MPC HN0 5MAX 00H	7.500
			Vijeo® Citect® Full 500 I/O	MPC HN0 JMAX 00V	7.500

(1) UL 60950 certified, not UL 508 certified.



MPC YB2 0NNN 00N



MPC YT5 0NNN 00N



MPC NB5 0NAN 00N



MPC YT9 0NNN 00N

Front Panels for Magelis® Flex PC BOX				
Screen size	Type of screen	Data entry via	Reference	Weight kg
12"	SVGA color TFT (800 x 600)	Touch screen and keyboard	MPC YB2 0NNN 00N	–
15"	XGA color TFT (1024 x 768)	Touch screen	MPC YT5 0NNN 00N	–
		Touch screen and keyboard	MPC NB5 0NAN 00N	–
19"	SXGA color TFT (1280 x 1024)	Touch screen	MPC YT9 0NNN 00N	–

2



MPC YN0 0HDS 30N



MPC YN0 0FSE 00N



MPC YN0 0BBU 00N

Separate parts for Magelis® Flex PC BOX				
Description	Specifications	Compatible with	Reference	Weight kg
RAID redundant hard disk	Removable cartridge ≥ 160 GB and RAID software	Flex PC BOX	MPC YN0 0RAI D0N	–
Hard disk	Removable cartridge ≥ 160 GB	Flex PC BOX	MPC YN0 0HDS 30N	–
Flash Disk	Removable cartridge ≥ 15 GB	Flex PC BOX	MPC YN0 0MSD 00N	–
PCI expansion	Adaptor for 2 PCI cards	Flex PC BOX	MPC YN0 0FSE 00N	–
Maintenance kit	–	Flex PC BOX	MPC YN0 0MKT 00N	–
DVD drive (reader/writer)	CD/DVD (reader/writer)	Flex PC BOX	MPC YN0 0CDW 30N	–
RAM expansion	512 MB	Flex PC BOX	MPC YFR AM05 12N	–
	1 GB	Flex PC BOX	MPC YFR AM10 24N	–
	2 GB	Flex PC BOX	MPC YFR AM20 48N	–
Screen adaptor Frame 1	Mechanical mounting interface for replacing an old Front	Flex PC BOX	MPC YN0 0FPF R1N	–
Screen adaptor Frame 2	Panel by a new one (see table below)		MPC YN0 0FPF R2N	–
Screen adaptor Frame 3			MPC YN0 0FPF R3N	–

Screen adaptor selection table			
From:	To:		
	MPC YB2 0N NN 00N	MPC YT5 0N NN 00N	MPC YB5 0N NN 00N
MPC NA2 0N NN 00N			
MPC NB2 0N NN 00N			
MPC NT2 0N NN 00N			
MPC NA5 0N NN 00N			
MPC NA5 0N NN 10N			
MPC NB5 0N NN 00N			
MPC NB5 0N NN 10N			
MPC NT5 0N NN 00N			
MPC NT5 0N NN 10N			

Adaptor	Color code
MPC YN0 0FPF R1N (Frame 1)	
MPC YN0 0FPF R2N (Frame 2)	
MPC YN0 0FPF R3N (Frame 3)	
Adaptation not possible	

Industrial PCs

Separate parts for all Magelis® iPC ranges

Separate parts for all the Magelis® iPC ranges			
Description	Size	Reference	Weight kg
Protective sheets (5 peel off sheets)	8.4" models	MPC YK10 SPS KIT	–
	12" models	MPC YK20 SPS KIT	–
	15" models	MPC YK50 SPS KIT	0.200
	19" models	MPC YK90 SPS KIT	–

Description	Details	Reference	Weight kg
Power supply connector	Replacement connector for AC supply voltage, for all Magelis iPC industrial PCs and iDisplay screens.	MPC YN0 0PWA CTE	–

2

Dimensions

Magelis® Smart BOX MPC SN01 N●J 00●

a	b	c	a1	a2	b1	c1	c2	c3
217	164	65	130	15	160	217	238	255

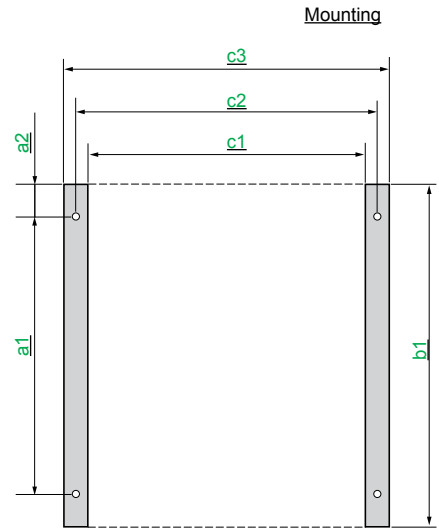
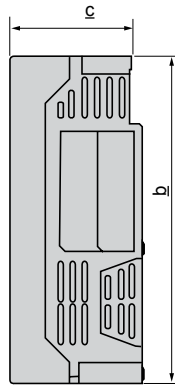
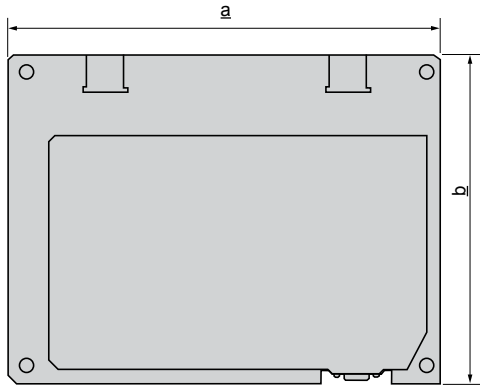
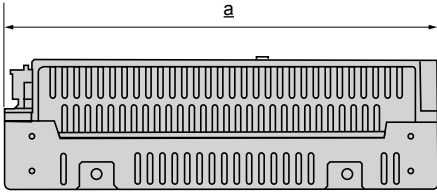

Magelis® Compact PC BOX MPC KN02 ●AX 00●

a	b	c	d	a1	a2	b1	c1	c2	c3
217	164	119	65	130	15	160	217	238	255

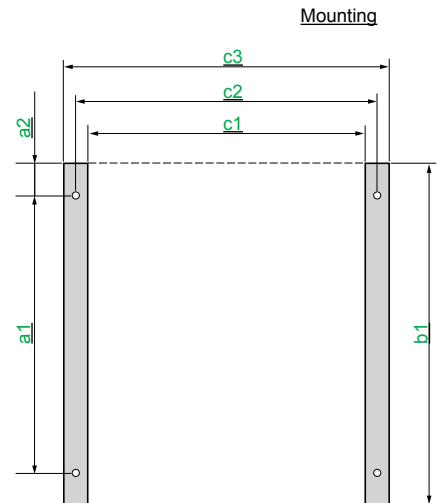
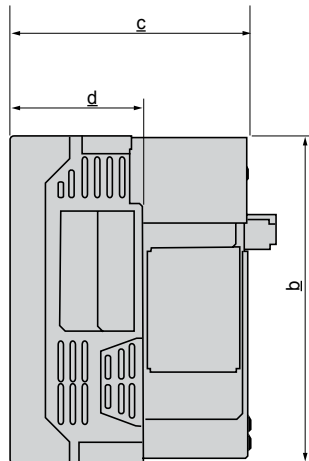
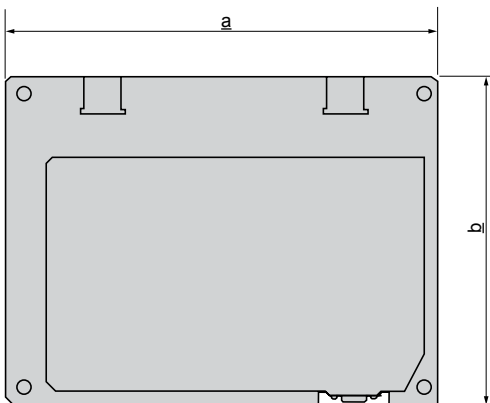
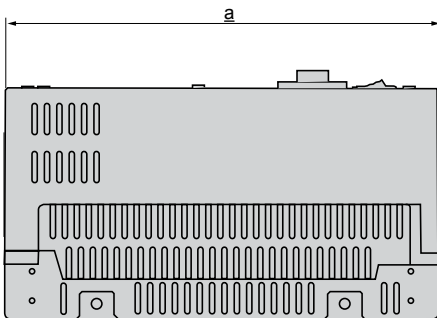

Dimensions (continued)

Magelis® FLEX PC BOX MPC ●N0 ●●X 00●

	a	b	c	d	e	f	g	a1	a2	a3	b1	c1	c2	c3
MPC FN0 ●●●X 00●	243	125	161	38	12	277	289	255	14	6	275	243	258	270
MPC HN0 ●●●X 00●	243	176	161	38	12	277	289	255	14	6	275	243	258	270

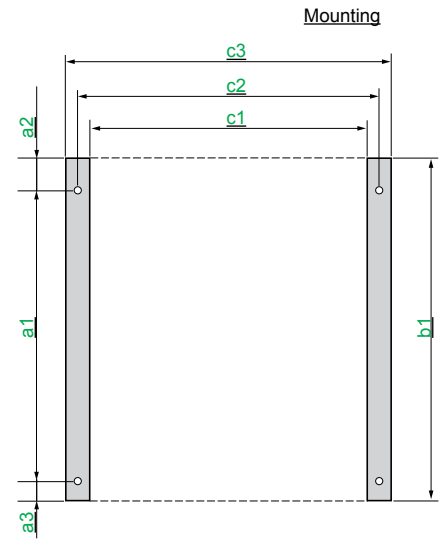
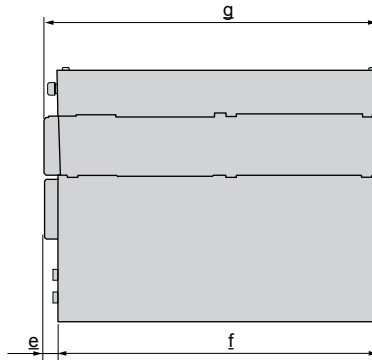
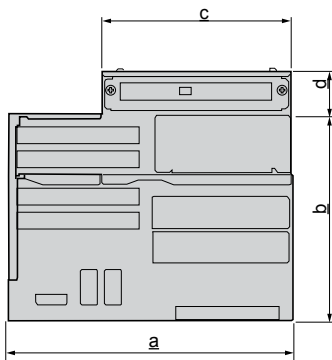
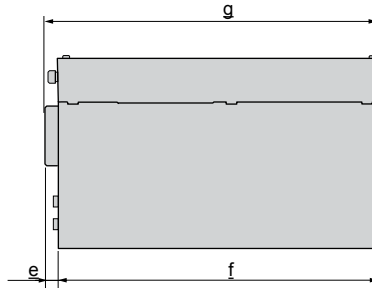
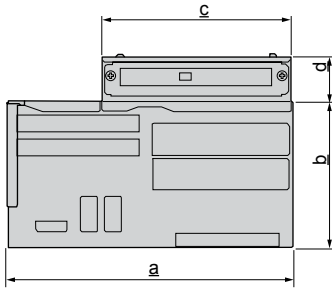

Mounting

The Magelis® Smart BOX, Magelis® Compact PC BOX and Magelis® FLEX PC BOX CPUs are mounted either horizontally or on a wall, using the fixing sets supplied. Use M4 screws.

Dimensions (continued)

Front Panel MPC Y●● 0NNN 00N

Type	Reference	a	b	A	B
12" touch screen and keyboard	MPC YB2 0NNN 00N	425	325	383.5	282.5
15" touch screen and keyboard	MPC NB5 0NAN 00N	488	367	441.5	313.5
15" touch screen	MPC YT5 0NNN 00N	425	325	383.5	282.5
19" touch screen	MPC YT9 0NNN 00N	460	390	419.5	352.5

2

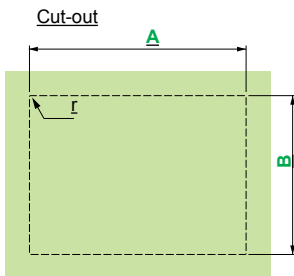
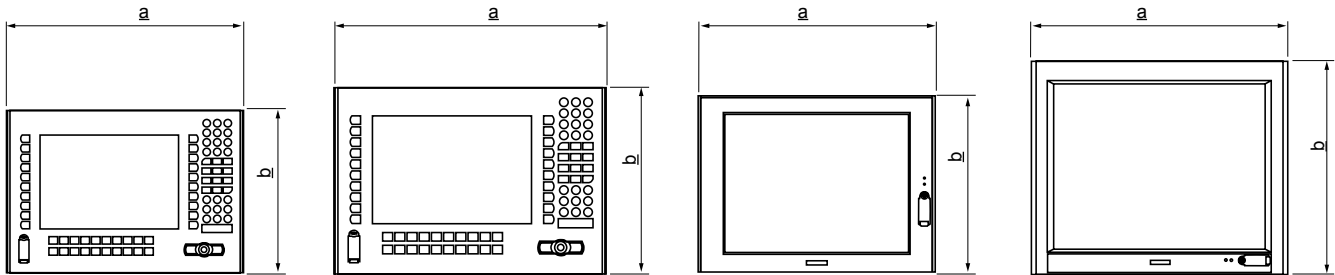

$$3 < r < 4$$

Dimensions (continued)							
Front Panel assemblies - Magelis® Flex PC BOX							
Type	Reference	a	b	c	d	e	f
12" touch screen and keyboard	MPC YB2 0NNN 00N	425	243	325	10	193.5	244.5
15" touch screen and keyboard	MPC NB5 0NAN 00N	488	333.4	367	10	193	244
15" touch screen	MPC YT5 0NNN 00N	425	304	325	10	193	244
19" touch screen	MPC YT9 0NNN 00N	460	441	390	12.7	206.5	258.5

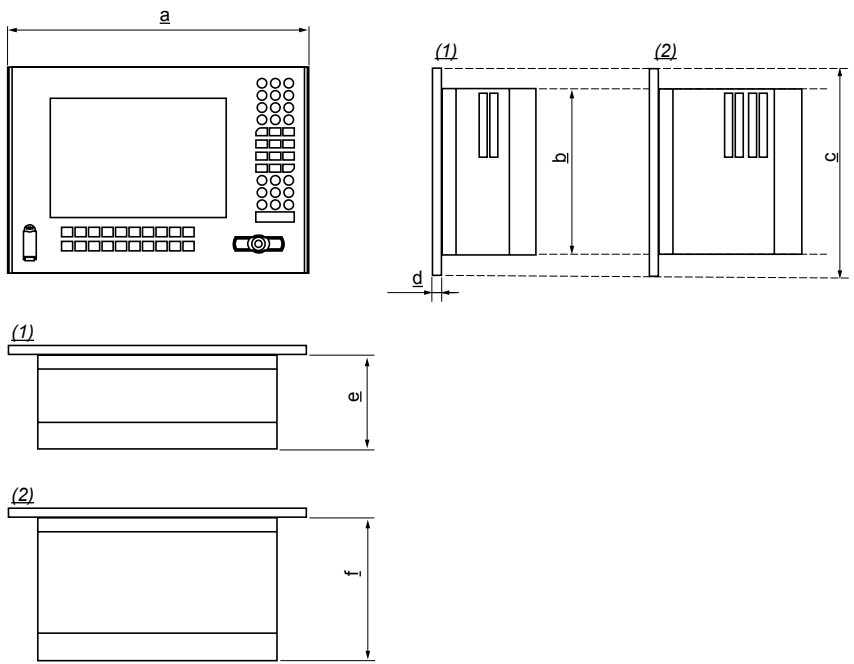

(1) Magelis® Flex PC BOX F CPU with 2 PCI slots.
 (2) Magelis® Flex PC BOX H with 4 PCI slots.

Industrial PCs

Magelis® Smart BOX
 Magelis® Compact PC BOX
 Magelis® Flex PC BOX

XBT GTW terminals and Smart BOX, Compact PC BOX and Flex PC BOX Industrial PCs

Connections to Schneider Electric devices

2

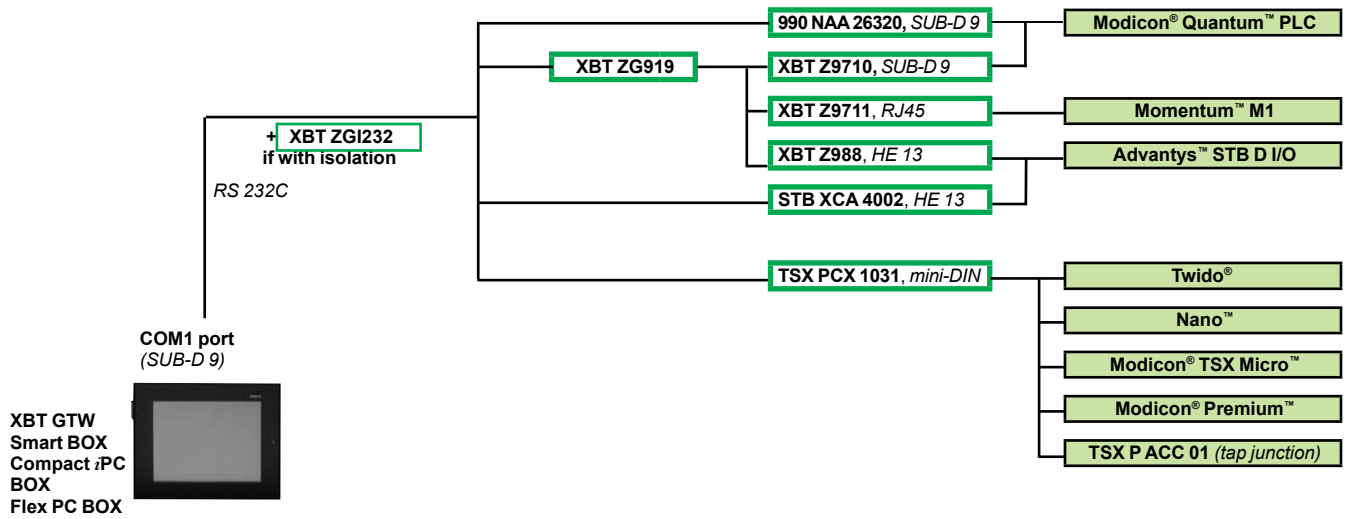

XBT GTW terminals and Smart BOX, Compact PC BOX and Flex PC BOX Industrial PCs

Connections to third-party devices

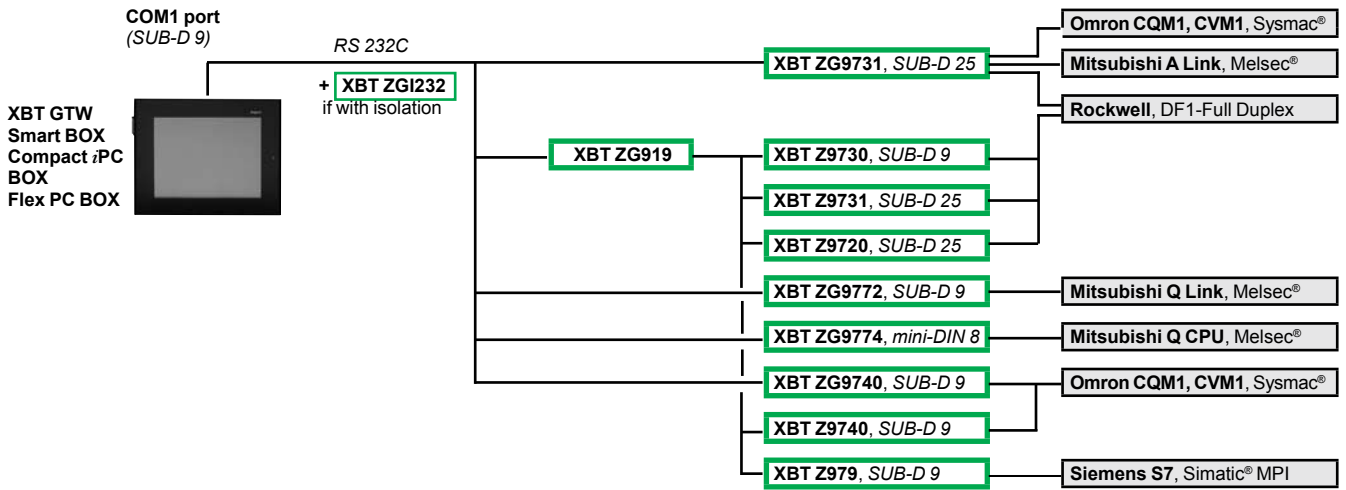

2



	15" touch & keypad	15" touch	19" touch
Touchscreen	15" LCD TFT	15" LCD TFT	19" LCD TFT
Resolution	XGA 1024 x 768	XGA 1024 x 768	SXGA 1280 x 1024
Front side port	1 x USB	1 x USB	1 x USB
Video ports	1 x VGA & 1 x DVI	1 x VGA & 1 x DVI	1 x VGA & 1 x DVI
Touchscreen ports	1 x USB & 1 x RS 232	1 x USB & 1 x RS 232	1 x USB & 1 x RS 232
Power supply	100 to 240VAC	100 to 240VAC	100 to 240VAC
Certification	UL508, CSA	UL508, CSA	UL508, CSA
Dimensions	483 x 365 x 65	395 x 294 x 60	460 x 390 x 65
References	MPCNB50NAN00N	MPCYT50NAN00N	MPCYT90NAN00N



MPC YT5 0NAN 00N



MPC NB5 0NAN 00N

Introduction

Magelis® iDisplay screens are monitors with industrial flat screens designed for use with PCs.

Two screen sizes are available: 15" and 19" to meet your requirements. Featuring the latest TFT LCD technology, Magelis iDisplay screens offer high quality visibility and extended service life. Their touch screen interface enables easy creation of user-friendly and high performance HMIs.

The Magelis® iDisplay screen **MPC NB5 0NAN 00N** also has a 70-key (standard IBM) keyboard and user function keys (2 x 20 keys).

Certified in accordance with PLC product standards and designed for use in severe industrial environments, these screens provide excellent size/dimensions ratio. They can be installed easily on machines and/or equipment, and are suitable for use in all types of environments.

With identical dimensions and same screen size as Magelis® Smart and Compact iPC industrial PCs, Magelis iDisplay screens can be used to visualise the development of installations with optimum ease and simplicity.

Architecture

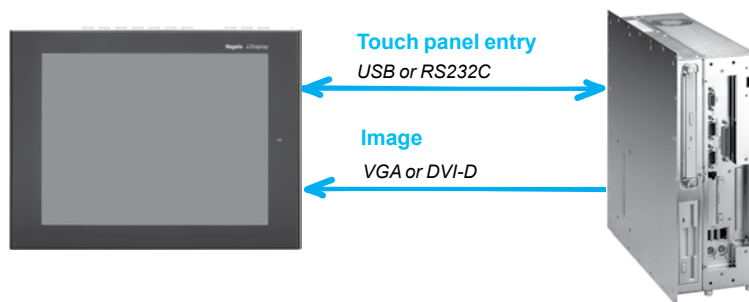

Specifications of Magelis® iDisplay flat screens

Type		MPC YT5 0NAN 00N	MPC NB5 0NAN 00N	MPC YT9 0NAN 00N
Environment				
Product certifications				
Temperature	Operation	0 to + 50 °C, conforming to EN 61131-2, UL		
	Storage	- 10 to + 60 °C, conforming to IEC 68-2-2 tests Bb and Ab, IEC 68-2-14 test Na and EN 61131-2	- 20 to + 60 °C	
Electrical characteristics				
Power supply	Voltages	~ 100...240 V (voltage limits 98...264 V), conforming to EN 61131-2	~ 100...240 V	~ 100...240 V (voltage limits 85...265 V), conforming to EN 61131-2
	Frequency	50/60 Hz (frequency limits 47/63 Hz), conforming to EN 61131-2	50/60 Hz	
	Micro-breaks	≤ 20 ms	10 ms	
Consumption		120 VA	200 VA	
Functional characteristics				
Screen	Type	Active matrix color TFT LCD		
	Size	15"	19"	
	Resolution	XGA 1024 x 768	SXGA 1280 x 1024	
	Number of colors	16 777 216		
	Brightness	≥ 200 cd/m ² , adjustable		
	Back-lighting (service life)	50 000 hours		
Touch panel		Analog resistive, 35 million cycles		
Keyboard		-	70 standard IBM keys 2 x 20 function keys	-
Inputs	Image	VGA or DVI-D port		
Outputs	Touch panel	USB or RS 232C port		

References				
Description	Specifications	Interface	Reference	Weight kg
Flat screen for flush mounting, IP 65 front panel, supplied with 3 m long cable.	15", XGA (1024 x 768)	Touch	MPC YT5 0NAN 00N	–
		Touch and keyboard	MPC NB5 0NAN 00N	–
	19", SXGA (1280 x 1024)	Touch	MPC YT9 0NAN 00N	–

Separate components		
Description	Reference	Weight kg
Maintenance kit: fixings + seals for Magelis® iPC 19"	MPC YK9 0MNT KIT	–
Protective film for screen on Magelis® iPC 19"	MPC YK9 0SPS KIT	–

Dimensions

iDisplay flat screens MPC YT● 0NAN 00N and MPC NB5 0NAN 00N

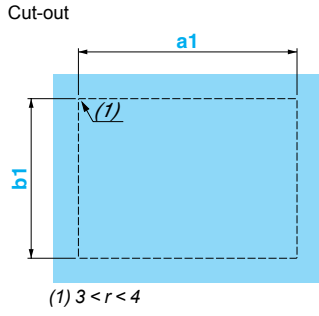
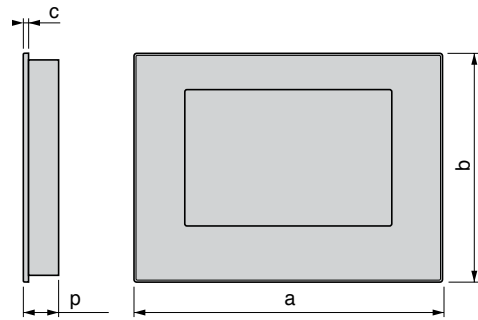

	a	b	c	p	a1	b1
MPC YT5	395	294	5	60	383.5 ⁺¹ ₀	282.5 ⁺¹ ₀
MPC NB5	483	365	10	31	441.5 ⁺¹ ₀	313.5 ⁺¹ ₀
MPC YT9	460	390	12.7	65	419.5 ⁺¹ ₀	352.5 ⁺¹ ₀

Mounting

Magelis® iDisplay flat screens can be mounted on a panel or enclosure door using the fixing parts (3 x 4 spring clips) included with each screen.



Type		Specifications		
Display	LCD screen size / Resolution	3.8" / QVGA	5.7" / QVGA	
	Type	STN monochrome, amber or red	STN monochrome, gray	STN 4096 colors
Functions	Representation of variables	Alphanumeric, bitmap, bargraph, gauge, button, light, clock, flashing light, keypad		
	Curves / Alarm logs	Yes, with log / Yes, incorporated		
	Control	5 languages IEC		
Communication	Serial link	-	1 Sub9 (RS 232/RS 422 - RS 485)	
	Networks	-	-	Ethernet, IEEE 802.3 10/100 BASE-T, RJ45
Downloadable protocols	Mitsubishi (Melsec®), Omron (Sysmac®), Rockwell Automation (Allen-Bradley), Siemens (Simatic®) Uni-TE™, Modbus®, Modbus TCP			
Development software	SoMachine® (on Windows XP® and Windows Vista®)			
Dimensions W x D x H	130x76x104mm		207x76x157mm	
Compatibility with PLCs	Twido®, Modicon® TSX Micro™, Modicon® Premium™, Modicon® Quantum™, Modicon® M340™			
Compact Flash card slot	No			
USB port Host type A	1	1	1	
Built-in Ethernet TCP/IP	No	No	Yes	
Integrated I/O	12I/6O 24 VDC		16I/16O 24 VDC	
Extensions	2 modules TM2 or CANopen module		3 modules TM2 or CANopen module	
Supply voltage	24 VDC			
References	Source Output	XBTGC1100T	XBTGC2120T	XBTGC2230T
	Sink Output	XBTGC1100U	XBTGC2120U	XBTGC2230U



Extensions

Type of module	CANopen Master
Specifications	Class M10 limited 16 slaves, Standard DS301 V4.02
References	XBTZGCCAN

Type of module	Digital Inputs / Outputs						
Specifications	8I 24 VDC Screw terminal	16I 24 VDC Screw terminal	16I 24 VDC HE10	32I 24 VDC HE10	8I 120 VAC Screw terminal	4I 24 VDC 40 Relays Screw terminal	16I 24 VDC 80 Relays Screw terminal
References	TM2DDI8DT	TM2DDI16DT	TM2DDI16DK	TM2DDI32DK	TM2DAI8DT	TM2DMM8DRT	TM2DMM24DRF

Type of module	Digital Inputs / Outputs					
Specifications	8O Transistor 24 VDC Screw terminal	16O Transistor 24 VDC HE10	32O Transistor 24 VDC HE10	8O Relays 230 VAC 30 VDC Screw terminal	16O Relays 230 VAC 30 VDC Screw terminal	
References	Source Output	TM2DD08TT	TM2DD016TK	TM2DD032TK	TM2DRA8RT	TM2DRA16RT
	Sink Output	TM2DD08UT	TM2DD016UK	TM2DD032UK	-	-

Type of module	Analog Inputs / Outputs					
Specifications	2I Current/Voltage	2I Thermocouple	4I Current/Voltage Temperature	8I Current/Voltage	8I Temperature	8I PTC
References	TM2AMI2HT	TM2AMI2LT	TM2AMI4LT	TM2AMI8HT	TM2ARI8LRJ TM2ARI8LT	TM2ARI8HT

Type of module	Analog Inputs / Outputs				
Specifications	1O Current/Voltage	2O Voltage	2I Current/Voltage 1O Current/Voltage	2I Temperature 1O Current/Voltage	4I Current/Voltage 2O Current/Voltage
References	TM2AMO1HT	TM2AVO2HT	TM2AMM3HT	TM2ALM3LT	TM2AMM6HT

3.1 - Configuration software

Selection guide	3/2
■ Vijeo Designer™ Lite configuration software	3/7
■ Vijeo Designer configuration software	3/17

3

Applications

Traditional architecture, HMI executed on PC platform or dedicated terminal
Configuration software for operator dialog applications



Target products Type
 Operating system on terminals

Magelis® XBT N, R, RT (1)
 Proprietary Magelis®

Functions
 Reading/writing of PLC variables
 Display of variables
 Data processing
 Sharing of variables between HMI applications
 Saving of variables to external database

Yes
 Yes
 –
 –
 –

Development of graphics applications
 Native library of graphic objects
 Container Active X®
 JavaBeans®
 Curves and alarms
 Scripts

Yes
 –
 –
 Yes (2)
 –

Online modification of applications

–

Communication between PLCs and HMI application

Via I/O drivers

Uploading of applications

Yes

Simulation of HMI applications

Yes

Redundancy

–

Recipe management

–

Report printing

–

Access security

Linked to user profiles

Software compatible with OS

Windows® 2000, Windows XP® or Windows Vista®

Type of software

Vijeo Designer™ Lite



Pages

3/7

(1) Magelis® XBT terminals behave transparently on restoration of power.
 (2) Depending on model

Traditional architecture, HMI executed on PC platform or dedicated terminal

Configuration software for operator dialog applications



Magelis® STO/STU, XBT GT, GK, GH, GTW (1)
Magelis® Smart, Compact iPC and PC BOX® (1)

Except Magelis® XBT GTW: Windows XP® embedded

Yes

Yes

Yes, using expression editor or Java® programming

–

–

Yes

–

Yes

Yes, with log

Java®

–

Via I/O drivers

Yes

Yes

–

Yes

Real-time alarms, log data

Linked to user profiles

Windows XP® or Windows Vista®

Vijeo Designer™



3/17

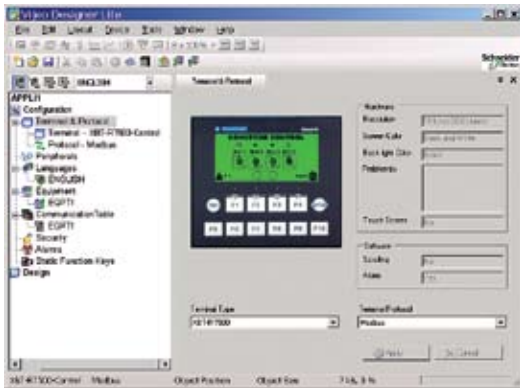

Vijeo Designer™ Lite configuration software enables the creation of simple operator dialog applications on Magelis® XBT N, R and RT Small Panel products. It also enables transparent recovery of all applications for Magelis XBT N and R produced using its predecessor: XBT L1000.

For simplified installation and improved consistency, Vijeo Designer™ Lite retains the main characteristics of Vijeo Designer™ software (ergonomics, interface ...) which has become the standard for the HMI field.

Configuration

Vijeo Designer Lite software enables fast and easy creation of different types of pages (application page, alarm pages, help pages...) and the installation of navigation between pages.

It offers:

- Graphic objects developed for Magelis XBT RT (bar charts, trend curves...)
- Character fonts Byzantine, simplified Chinese, Cyrillic, Japanese
- Project reports
- Application simulation on PC
- Six languages: English, French, German, Italian, Spanish and Chinese.

Number of licenses

Single (1)

Composition

Without cable
With USB cable

References

VJDSNDTMSV●●M
VJDSUDTMSV●●M

Software is delivered on CD-ROM and can be executed under Windows® 2000, Windows XP® and Windows Vista®. ●● represents version number.

These references are downloadable on Schneider-Electric.com

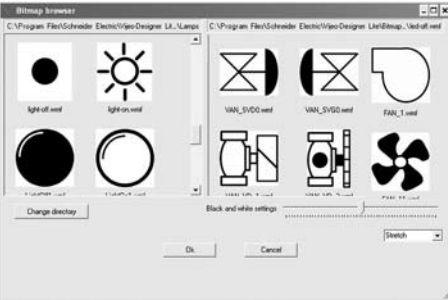

Symbols library



Communication table

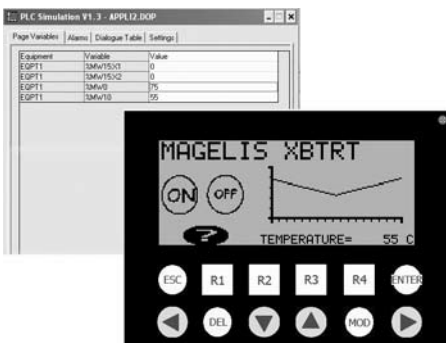

Simulation

Graphics editor

The graphics editor in Vijeo Designer™ Lite makes it easy for developers of user-interface applications to create pages based on objects:

- Point, line, rectangle, ellipse
- Text and image
- Graphic, trend curve, button, indicator
- Enumerated list and scrolling text

Symbols library

The symbols library makes the process of creating pages even more efficient. It contains pictograms which are easily recognizable within an industrial context as well as drawings of the main components used in automation. With Vijeo Designer Lite, the user can instantaneously link these graphic symbols with function keys on the terminal.

Links with PLC variables

Vijeo Designer™ Lite also enables the user to link symbols with the internal variables of Schneider Electric PLCs by importing TwidoSoft™, PL7™ and Concept™ automation database files.

Communication table

The Communication table in Vijeo Designer Lite provides the user with an easy way of configuring all data exchanged between the Magelis® compact XBT terminal and the main device.

The Communication table can also be used to define:

- Access to data: read/write
- All the alarm conditions

Simulator

Vijeo Designer™ Lite makes it possible to simulate the entire user-interface application at design office level without using a Magelis® compact terminal or a PLC.

The simulator program can be used to thoroughly check the following application characteristics:

- Navigation between pages
- Entry of variable data
- Variable display
- Alarm display

Application printing

The print function for Vijeo Designer Lite can be used with part or all of the HMI application. It is possible to send the data to a printer or to print to file.

New features of Vijeo Designer™ Lite 1.3

- Direct support of Zelio® Logic on XBTN401, XBTR411, XBTRT511
- All XBTRT graphical objects are now available on XBT N/R
- 3 new graphical objects : enumerated list of text & bitmap, static text
- Enhancement of Windows Vista® support (user mode)
- Enhancement of Simplified Chinese support
- Support of 'Little Endian' / 'Big Endian' mode in all protocols
- New option for alarm on-line printing

Specifications of Vijeo Designer™ Lite applications

Schneider Electric protocols

Vijeo Designer™ Lite supports Schneider Electric protocols:
 - Modbus® RTU Master, Slave
 - Uni-Telway™

Specifications of the Vijeo Designer™ Lite software

Operating system compatibility	Windows® 2000 Windows XP® Professional Windows Vista® Professional, 32-bit
Application validation	Calculation of the maximum memory space occupied by the application. Verification of the capacity of the target (Magelis® compact XBT terminal) configured to run the application: - Physical memory capacity - Available functions If applicable: - Disabling of application upload/download - Direction towards sections of the online help, which will provide tips for optimizing the application
Interface languages	Vijeo Designer Lite software screens and online help available in English, French, German, Italian, Simplified Chinese and Spanish
Documentation	Available in electronic format in English, French, German, Italian, Simplified Chinese and Spanish. Not available in hard copy
User licenses	Four types of license are available: - <i>Single</i> : one station - <i>Group</i> : 3 stations - <i>Team</i> : 10 stations - <i>Facility</i> : unlimited number of stations on one site Supplied with or without transfer cable(s), for serial link or USB port (see table of references for each Magelis® compact terminal on page 3/7).
Registration	Recommended (via fax, e-mail or web site www.schneider-electric.us/swregistration), provides access to additional resources such as application examples, etc.
Third-party protocols	
	Vijeo Designer Lite also supports the following protocols and PLCs:
Mitsubishi	Melsec® FX protocol (CPU)
Omron	Sysmac® protocols
Rockwell Automation	Allen-Bradley protocols: DF1-Full Duplex, RS DataHighway 485
Siemens	Simatic® PPI protocols





References

All licenses for the Vijeo Designer™ Lite configuration software listed below include a CD-ROM containing:

- Vijeo Designer Lite V1.3 software
- User documentation in electronic format
- The communication protocols described on page 3/6.
- XBT L1001 development software for converting existing XBT applications

Single-station licenses

Designation	License type	Application transfer cable included		Reference	Weight kg
		PC-side port	Terminal side Magelis® XBT/ Magelis® iPC		
Vijeo Designer™ Lite configuration software	Single (1 station)	–	– (1)	VJDSNDTMSV13M	0.125
		USB		VJDSUDTMSV13M	0.675

Multi-station licenses

Designation	License type	Number of stations (1)	Reference	Weight kg
-------------	--------------	------------------------	-----------	--------------

Group, Team and Facility licenses are no longer required for Vijeo Designer™ Lite. There are no restrictions for number of users per license for Vijeo Designer Lite 1.3. Vijeo Designer Lite 1.3 can be downloaded free of charge from www.schneider-electric.us/

(1) Separate parts: For application transfer cables (PC to XBT N/R/RT terminal), see page 1/20.

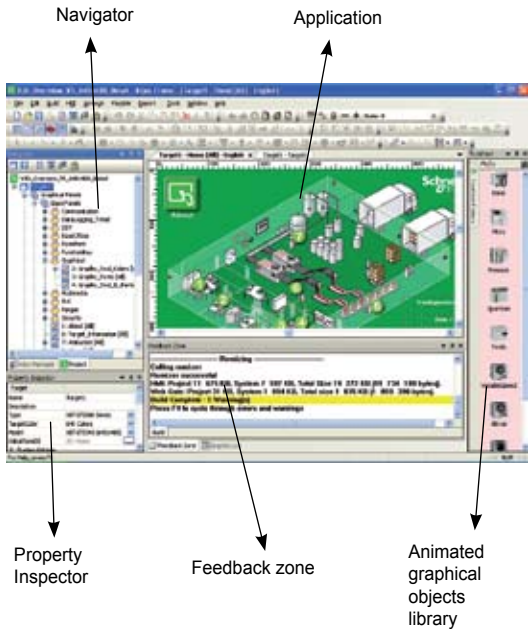

Vijeo Designer™ configuration software enables creation of automated system control operator dialog applications for Magelis® STO/STU, XBT GT, GK, GTW, GH terminals and Smart & Compact iPC and PC BOX. It also enables management of the multimedia functions of XBT GTW and Smart & Compact iPC (video and audio), as well as offering users of Ethernet terminals and iPC remote access via a Web browser (WEB Gate function).

Configuration

Vijeo Designer™ configuration software enables fast, simple processing of operator dialog projects thanks to its ergonomics, developed around 6 configurable windows.

It also offers comprehensive application management tools, including:

- Project creation; projects comprising one or several targets (terminal or iPC).
- Recipe editor (32 groups of 256 recipes of max- 1024 ingredients).
- User action list (eg- script) for application adaptability.
- Application variable cross-referencing.
- Vectorial graphic library for more attractive graphic screens.
- Application block diagram documentation.
- Simulation mode for simple design office application testing.
- High-performance graphic editor for simple block diagram creation (over 30 animated pre-configured generic objects).
- Support of layers and masks for faster development.
- Data sharing (up to 300 variables on 8 terminals).
- Management of 40 alphabets (including simplified Chinese, Korean, Arabic and Hebrew) with the opportunity to have 15 languages per application and dynamic change.
- Programmable controller database sharing (Unity™ Pro, PL7™, Concept™, TwidoSoft™, ProWORX™, ModSoft™), process variables or operators actions
- Advanced traceability function (periodic, at event or on request).
- Project backup on terminal for simple maintenance.
- User-friendly data recovery tool.
- Support of standard USB peripherals (USB key up to 4 GB).
- Support of external USB keyboards and mice.
- Integration with Schneider Electric equipment (buffer diag., variables access, Unity DDT and unlocated variables.)
- Event-triggered e-mail function
- Over 35 third party protocols
- Multilingual software: English, French, German, Italian, Spanish, Portuguese and Simplified Chinese.
- Printing function

The Vijeo Designer™ Limited Edition, downloadable or free access allows you to configure the Magelis STO/STU.

Number of licenses	Composition	References
Single (1)	Without cable With USB cable	VJDSNDTGSV●●M VJDSUDTGSV●●M
Group (3)	Without cable	VJDGNDTGSV●●M
Team (10)	Without cable	VJDTNDTGSV●●M
Facility (Unlimited)	Without cable	VJDFNDTGSV●●M

The software is supplied on DVD and runs under Windows XP®, Windows Vista® and Windows 7. ●● represent the version number.

Runtime for Magelis® iPC	Composition	References
Single (1)	Without cable	VJDSNRTMPC



Graphics editor

The graphics editor in Vijeo Designer™ offers interface consistency for simple objects as well as for more sophisticated ones. It enables application developers to create mimics easily based on:

- Simple objects to be configured:
 - Points, lines, rectangles, ellipses, arcs
 - Bar graphs, gauges, tanks, fillers, pie charts, curves
 - Polylines, polygons, regular polygons, Bézier curves, scales
 - Texts, images or alarm summary, etc.
- Preconfigured advanced objects: Switches, radio buttons, indicators, buttons, tanks, bar graphs, potentiometers, selector switches, text or number fields, enumerated lists, etc.
- Screen masks and skeletons for type applications

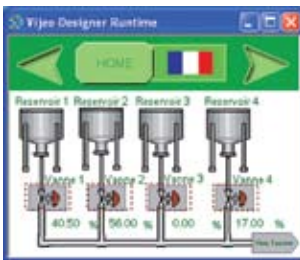

Object animations

8 types of graphic-object animation support the rapid creation of animated mimics for:

- Pressing the touch panel
- Change of color
- Filling
- Movement
- Rotation
- Size
- Visibility
- Display of associated value

Library of animated graphic objects

The library of animated graphic objects makes the creation of mimics very efficient thanks to the numerous "ready-made" animation objects. It includes more than 4000 "industrial" vector images in 2 or 3 dimensions. Simply "drag and drop" the object using the mouse to position it on the mimic being created.

User-defined objects can be added to this library using the same simple "drag and drop" method.

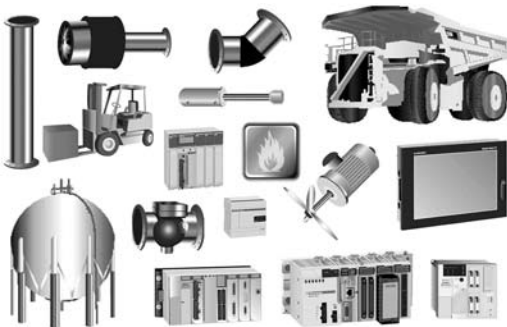

Java® scripts

Vijeo Designer™ supports the processing of information using Java® language scripts. This function facilitates the running of complex animations, the automation of tasks within the terminal, and the management of calculations to relieve the load on the PLC programs.

The scripts (50 lines, max.) can be associated with:

- Variables
- Operator actions
- Screens
- The application itself

User-customizable resources

To enable applications to be customized in accordance with customer requirements, Vijeo Designer™ features a new resource concept, i.e. the possibility of defining styles (colors, images, character fonts, text lists).

To customize a generic application in accordance with customer requirements quickly, simply assign these styles to the objects concerned.

The resource concept is supported by the following native objects: *Meter*, *Bar Graph*, *Slider*, *Potentiometer*, *Selector*, *Text List* and *Image List*.

```

//Script Created: 10/09/2001
// Description:
//
// Replace this line with your script
int pos;

if (movebottles.getintValue() != 0) // If conveyor is OFF, do not move bottles
{
    pos = BottlePos.getintValue();
    if (pos >= 1000)
        pos = 0; // If bottle position has been the out of display area, reset position
    pos = pos + 10 + 2 * ConveyorSpeed.getintValue();
    BottlePos.wide(pos);
}
    
```



Data Manager: Transfer recipes, videos, images, etc. via Ethernet or USB, by simply clicking the mouse.



Alarm management



Report printing

Advanced functions

Based on new information technologies, Vijeo Designer™ features a large number of advanced functions for processing a higher volume of data, both faster and more reliably:

- Multimedia data management in the following formats:
 - Image display (jpeg, bmp, emf and png files)
 - Text display and processing (txt files)
 - Sound-message processing (wav files)
- Alarm or curve logs recorded
- In/out zoom function for a focused analysis of trend curve displays
- Alarm management. All variables can be categorized as "Alarms" and can be customized in respect to visualization and acknowledgment. These Boolean and analog-threshold type alarms can be printed in real time.
- Multimode application transfer: via serial link, USB, Ethernet and Compact Flash memory card (on multifunction terminals)
- Back-up of application source files on the terminal or iPC to facilitate maintenance
- User-friendly data exchange between PC and terminal using the Data Manager tool
- Integrated FTP server for downloading/uploading recipes via Ethernet TCP/IP and restoring logs to XBT GT/GK/GTW and Magelis® iPC terminals
- Multiport communication for multifunction terminals - 2 serial links and 1 Ethernet network can be active simultaneously.
- Action table for associating a particular behavior with an event
- Using a USB memory stick (up to 2 GB) to download an application, retrieve data or exchange recipes

WEB Gate remote connection

Vijeo Designer™ can provide a WEB Gate remote connection for any platform equipped with an Ethernet port and Compact Flash or hard disk memory. This includes: XBT GT/GK/GTW (XBT GT2110 and higher), Magelis® Smart, Compact iPC HMI edition and PC BOX.

WEB Gate supports remote visualization of Vijeo Designer™ applications with Internet Explorer® on any PC running Windows XP® or Windows Vista®. The size of the page displayed is determined by the terminal.

WEB Gate supports the display of pages similar to those in the Vijeo Designer application, or of different pages, including: startup pages and navigation pages that can be differentiated in order to indicate the type of access (terminal/WEB Gate).

It is possible to have more than one connection at the same time, with the number of connections depending on the size of the application.

WEB Gate's high-security mode reduces risk of applications jamming as a result of variables being modified via the terminal and WEB Gate at the same time.

For increased confidentiality:

- WEB Gate access can be restricted to only those PCs whose IP address appears in the licensing list.
- Some Vijeo Designer functions are not supported by WEB Gate:
 - Application shutdown, restart
 - Terminal configuration
 - Read an acoustic animation (sound file)
 - Display a recorded video sequence

WEB Maintenance remote diagnostics

In addition to WEB Gate, Vijeo Designer™ features the embedded diagnostics service WEB Maintenance - Transparent Ready® WEB Server Class B15 (1) - this server's navigation bar features an option for accessing the WEB Gate function.

Note: Terminals programmed using Vijeo Designer can be accessed directly via their names. This function is supported by the DHCP and DNS network services.

(1) Please consult our "Control and automation, Ethernet TCP/IP and the Web" catalog.

Specifications of Vijeo Designer™ applications

General characteristics

Number of targets	32, either XBT GT/GK/GTW terminals or Magelis® Smart HMI edition, Compact iPC HMI edition and PC BOX industrial PCs					
Number of internal and external variables	8000					
Number of lines per Java® script	50 (1)					
Sharing data between terminals	Up to 300 variables between 8 terminals, without router PLC. Proprietary protocol above TCP/IP.					
Internationalization	Up to 15 languages supported by 34 western alphabets, 4 Asian alphabets, 2 middle eastern alphabets:					
Western alphabets	Afrikaans	Belarusian	Spanish	Dutch	Lithuanian	Romanian
	Swedish	Albanian	Bulgarian	Estonian	Hungarian	Macedonian
	Russian	Czech	German	Catalan	Finnish	Indonesian
	Norwegian	Serbian	Turkish	English	Croatian	French
	Italian	Polish	Slovak	Ukrainian	Basque	Danish
	Greek	Latvian	Portuguese	Slovenian		
Asian alphabets	Simplified Chinese	Korean	Japanese	Taiwanese		
Middle eastern alphabets	Hebrew	Arabic				
Functions	Languages can be programmed or selected dynamically via the menu. The character fonts are embedded in the application. The process is based on the export/import of texts in CSV format, which can be edited by the translator (each text is stamped with a unique ID).					
Keyboards that can be used to enter data	Three types of keyboard are available: - Standard AZERTY or QWERTY - Alphabetical - Compact, suitable for small screens and for pages with priority display zones					
Storage of source code	- The application source code can be stored either on the terminal or on the iPC. - A password provides confidentiality. - On request, the application can be verified each time the terminal starts up by means of a CRC calculation <i>High Security</i> function).					

Specifications of pages

Internal or external variables	800
Objects	800
Switches	30
Pop-up windows	3
Number of lines per Java script	50 (1)

Library of graphic objects

Number of objects available	> 4000
Type	2D and 3D "industrial" vector images
Can be expanded?	Yes

Recipes

Number of groups	32
Composition of a group	Up to 1024 ingredients for 256 recipes
Multilingual support	Complete for labels and ingredients

Action tables



Number of actions	100
Composition	Maximum of 16 commands per action
Action type	- Periodic - Planned - Conditioned - Event-based

(1) Indicative data for a script executed cyclically



Specifications of Vijeo Designer™ applications (continued)

Alarms	
No. of alarms activated, record or logs	9999
Type	Any variable (internal or external, Boolean or analog-threshold) can act as an alarm.
Easy customization	Any alarm-type variable can be customized in respect of visualization and acknowledgment.
Associated reflex functions	Any alarm-type variable can be associated with reflex functions linked to the appearance of the alarm concerned: - Action on appearance - Action on selection - Message for the alarm bar, etc.

Integrated diagnostics		Modicon® M340™ Unity™ Pro	Modicon® Premium™ PL7™	Modicon® Premium™ Unity Pro	Modicon® Quantum™ Unity Pro
The PLC "Diag buffer" function can be accessed via the following protocols:	UNITE series	Accessible	Accessible	Accessible	Accessible
	UNITE-TCP/IP XWAY™	Accessible	Accessible	Accessible	Accessible
	UMAS Modbus® TCP	Accessible	Accessible	Accessible	Accessible
	UMAS Modbus RTU	Accessible	Accessible	Accessible	Accessible
	UMAS Modbus Plus™	Accessible	Accessible	Accessible	Accessible
	UMAS UNITE series	Accessible	Accessible	Accessible	Accessible
	UMAS UNITE-TCP/IP XWAY	Accessible	Accessible	Accessible	Accessible
	UMAS Modbus TCP USB PPP	Accessible	Accessible	Accessible	Accessible
		 Accessible			
		 Not accessible			

Video functions		
Platform	XBT GT terminals	XBT GTW terminals Magelis® Smart HMI edition Magelis® Compact iPC HMI edition PC BOX
Video source	NTSC, PAL video channel	Webcam
Input format	Composite video (chrominance+luminance) via RCA plug	Webcam via USB port
Display resolution	NTSC: 640 x 480 pixels PAL: 768 x 576 pixels	Depending on webcam characteristics (usually 640 x 480 pixels)
Duration of dynamic memorization	10 mins. max., can be configured, in circular memory (MPEG-4 format)	–
Recording of sequences		
Media	Compact Flash card	Compact Flash card Hard disk
Number of sequences	Up to 200	
Recording format	Simple MPEG-4 profile	
Recording resolution	320 x 240 pixels	
Typical recording rate	3.2 MB/minute	Determined by the CODEC used on the PC
Typical capacity	Up to 28 sequences lasting up to 10 minutes can be stored on a 1 GB Compact Flash card.	Determined by the space available on the hard disk

Specifications of Vijeo Designer™ applications (continued)	
Screen capture	
Format	JPEG
Resolution	Display resolution
Ranges supported	XBT GT terminals (XBT GT 1105 and higher), Magelis® Smart HMI edition, Magelis® Compact iPC HMI edition and PC BOX industrial PCs
Video window included	Yes
Backup	
Format	JPEG
XBT GT 1105 terminals and higher	On Compact Flash card
Magelis® Compact iPC industrial PCs	On Compact Flash card On hard disk
Transfer	
	Via USB memory stick or Data Manager on the terminal or on an iPC equipped with an Ethernet connection or USB port
Printing	
XBT GT 1105 terminals and higher	Via USB port (1) or Ethernet port, with a compatible printer (2): PCL5 - HP Officejet Pro™ - HP LaserJet® PCL3 - HP Deskjet™ series - HP Business InkJet™ - HP Officejet Pro™ - HP LaserJet® - HP Photosmart™ series ASCII
With the Magelis® Smart and Compact iPC HMI edition industrial PCs and later	With any printer equipped with a suitable driver for Microsoft Windows®
Creating and printing reports and barcodes	
Creating reports	
	Reports are created in the same way and with the same WYSIWYG editor as for Vijeo Designer™ pages.
Report printing	
XBT G terminals	Text printer via: Parallel port COM port
XBT GT terminals	Text printer via: COM port USB port with PIO adapter NB: printers with a USB port and network printers are not supported.
Magelis® iPC, PC BOX	Based on Windows printing configuration, using a text printer via: Parallel port COM port Network
Barcode printing	
	Can be done by sending special characters to switch the printer to barcode printing mode Main barcode types supported: UPC-A UPC-E JAN/EAN8 JAN/EAN13 ITF CODE39 CODE93 CODE128 CODABAR (NW-7)
Internet Explorer® browser object	
Support	Pages created in Vijeo Designer™ for Magelis® Smart, Compact and iPC HMI edition can feature a Microsoft Internet Explorer browser object.
Possible functions	Display, in all or part of the Vijeo Designer screen page, of: - HTML format pages: e.g., web sites, pages from Microsoft Office®, Microsoft Word, Excel® and Powerpoint® documents saved in HTML format - Documents in Adobe® pdf format - Macromedia Flash® presentations - Video sequence (<i>streaming</i>) originating from a video server on IP - Any other Active X® featuring a USB port

(1) A printer can be connected to the USB port of XBT GT terminals (XBT GT 1105 and higher) as long as the printer connection is serial or parallel. A serial-to-USB or parallel-to-USB conversion cable is also required.

(2) For a complete list of Hewlett Packard and other manufacturer printers supported, please consult your Regional Sales Office.

Specifications of Vijeo Designer™ applications (continued)

Displaying user documentation pages on the XBT GT/GK

Support	User documentation stored on the Compact Flash card of the XBT GT/GK can be displayed with Vijeo Designer™, provided it is in HTML V4.01 CSS 1.0 format. Most DTP software supports export to HTML format: Adobe Acrobat®, Microsoft® Word, Microsoft Powerpoint®, etc.
---------	---

Schneider Electric applications

Support	Pages created with Vijeo Designer for Magelis® Smart, Compact iPC and PC BOX can run Schneider Electric software in a window that is independent of the Windows® system.
Possible functions	It is also possible to run frequently-used application software as and when required, including: <ul style="list-style-type: none"> - Unity™ Pro - TwidoSuite™ - Advantys™ STB configuration software - PL7™ - PowerSuite™, etc.

Traceability, logs

	Vijeo Designer offers increased flexibility for implementing data traceability by means of sampling and management of log files. Every variable can be written in a recording group. All data is time and date-stamped (based on GMT) to facilitate comparison of data from different sites. <i>Time Zone</i> and DST are also supported so that local characteristics such as the change from winter to summer time can be taken into account. A recording group defines the following elements:
Recording type	<ul style="list-style-type: none"> - Periodic - Event-based
Storage media	<ul style="list-style-type: none"> - Compact Flash memory card - SRAM terminal memory (for alarms) - Hard disk (Magelis® Compact iPC and PC BOX)
Maximum size	<ul style="list-style-type: none"> - Maximum number of recordings - Maximum file size

Capacity
The designer of the application concerned is entirely free to select the number of variables sampled and the sampling frequency (these will be determined by the media present on the target). The following are typical example values:

Target terminal	XBT GT/GK	XBT GTW	Magelis® Smart HMI edition	PC BOX Magelis® Compact iPC HMI edition
Number of variables sampled	100	250		
Target storage medium	Compact Flash card			Hard disk
Maximum duration and size of samples per variable	Up to 5 years of recordings Up to 8 MB of samples per variable			

Data Manager

	The user-friendly Data Manager tool is used to transfer data from and to a terminal. This copyright-free program does not require Vijeo Designer to be installed and can be installed independently for the following types of transfer:
Logs	<ul style="list-style-type: none"> - Recovery of log data for variables - Conversion into a single CSV format file
Recipes	<ul style="list-style-type: none"> - Transfer from and to terminal - Modification using an integrated editor
Project	- Download to PC of the project stored on the Compact Flash memory card
Video sequences, screen captures	- Download to PC

Data sharing

	Vijeo Designer™ offers the possibility of sharing data between terminals (this option simply needs to be configured). The system works without a router PLC. Up to 300 variables can be shared between a maximum of 8 terminals. The exchange protocol is a TCP/IP proprietary upper layer. The high-security mode reduces risk of applications jamming, which can occur when attempts are made to modify a variable via more than one terminal at the same time.
Restrictions	Vijeo Designer™ imposes the following restrictions on the sharing of data:
Sharing of external variables on the terminal	These variables cannot be used in the following objects: <ul style="list-style-type: none"> - Trend graphs - Data graphs These variables cannot be saved via the terminal.
System and recipe variables	The direct sharing of these variables by means of configuration settings is not supported. However, sharing can be programmed using the <i>ReadFromVar</i> and <i>WriteToVar</i> functions.

Specifications of Vijeo Designer™ applications (continued)

Terminal access security

	Access to all or some of the objects in Vijeo Designer™ can be made subject to users proving that they are in possession of sufficient rights (user name and password).
Type of right	- Application: pages, buttons with confirmation, etc. - Data Manager: access via FTP service - Web Gate: intranet/extranet access (IP address filtering)
Number of users per group of rights	Up to 100
Number of groups of rights	Up to 20
Automatic locking	If active: automatic blocking of access via keyboard if no entries are made for a set period of time

Target security

	Vijeo Designer™ can increase the confidentiality of applications on Magelis® Smart HMI edition, Compact iPC HMI edition and PC BOX by putting protection mechanisms in place at two levels:
BIOS	- Disabling of startup via peripheral connected to USB port - Disabling of USB ports - Password protection for BIOS access
Run-Time Vijeo Designer™	- Hiding of Windows® taskbar - Disabling of toggling between tasks (ALT+TAB) - Disabling of Windows Security Manager (CTRL+ALT+DEL), including the Task Manager - Disabling of Windows shortcuts - Disabling of the "Windows logo" key on the keyboard - Disabling of shortcut to exit run time (CTRL+Z)

Schneider Electric protocols

	Vijeo Designer™ supports Schneider Electric protocols: - Modbus® RTU Master - Modbus TCP/IP Master - Modbus Plus™ (1) - ELAU® PacDrive® - Uni-Telway™ - UniTE TCP/IP - USB terminal port for Modicon® M340™ CPUs - FIPIO® (5), FIPWAY® (5) All Schneider Electric drivers offer IEC access to input and output bits/words: Modbus (RTU and TCP/IP), Modbus Plus (GMU and USB), Uni-Telway, Xway™. Direct I/O access authorizes access to hardware input and output registers. Register addresses comply with the syntax of IEC standards and the address rules for UNITY™ configuration software (%I, %IW, %Q, %QW). If requested by the user, the variables associated with a PLC can be read ("on demand scan" function). The DDT and unlocated variables of Unity™ Pro are supported.
--	---

Third-party protocols

	Vijeo Designer™ also supports the following protocols and PLCs:
Mitsubishi	Melsec® protocols: A/Q CPU (SIO), A/Q Ethernet (TCP), A Link (SIO), QnA CPU (SIO), Q Ethernet (UDP), FX (CPU), FX 3U (CPU). Except for Melsec-A Link (SIO), Mitsubishi serial link protocols do not work on the RJ45 port (1).
Omron	Sysmac® protocols: FINS (SIO), LINK (SIO), FINS (Ethernet) and Trajexia. OMRON serial link protocols do not work on the RJ45 port. (2)
Rockwell Automation	Allen-Bradley protocols: DF1-Full Duplex, RS DataHighway 485, Ethernet IP (3) (PLC5, SLC500, MicroLogix, ControlLogix®), Ethernet IP native (2) (ControlLogix), DeviceNet Slave (6)
Siemens	Simatic® protocols: MPI (S7-300/400), MPI Direct, RK512/3964R (S7-300/400), PPI, Siemens Ethernet. The S7-300/400 MPI Adapter and RK512/3964R - RS485 connection serial link protocols do not work on the RJ45 port. (2) Profibus DP protocol: via XBT ZG PDP (4)

(1) Via USB cable: XBT ZG UMP for XBT GT 2●●● and higher, TSX C USB MBP for Smart and Compact iPC

(2) They are supported on XBT GT (SUB-D connector, XBT GT2 and higher).

(3) Certified ODVA compatibility

(4) Certified by Profibus Foundation

(5) Via the USB FIPIO® module: TSX CUSB FIP

(6) Via the DeviceNet module: XBT ZGDVN

Specifications of the Vijeo Designer™ software (continued)	
Operating system compatibility	Windows XP® Professional Windows Vista®
Graphic library	Library of vector graphic objects shared with Vijeo® Citect®
Number of objects available	> 4000
Type	2D and 3D "industrial" vector images
Can be expanded?	Yes
Application validation	Calculation of the maximum memory space occupied by the application. Verification of the capacity of the target (XBT GT terminal, Magelis® Smart and Compact iPC HMI edition) configured to run the application: - Limits of the physical memory - Available functions If applicable: - Disabling of application upload/download - Direction towards sections of the online help, which will provide tips for optimizing the application
Interface languages	Vijeo Designer™ software screens and online help available in English, French, German, Italian, Simplified Chinese, and Spanish
Documentation	Available in electronic format in English, French, German, Italian, Simplified Chinese, and Spanish. Not available in hard copy
Self-learning	Multimedia tool (1 hour 30 minutes) in English/French included
User licenses	Four types of license are available: - <i>Single</i> : one station - <i>Group</i> : 3 stations - <i>Team</i> : 10 stations - <i>Facility</i> : Unlimited number of stations on one site Supplied with or without transfer cable(s) for USB port: XBT ZG 935 , see table of references for each Magelis® terminal on page 3/17.
Saving	Recommended (via fax, e-mail or web site www.schneider-electric.us//swregistration), provides access to additional resources such as application examples, etc.
Services	
Switch2VijeoDesigner: migration of XBTL 1000 applications	The Switch2VijeoDesigner service offer makes it even easier to migrate XBTL 1000 applications created on XBT F terminals to Vijeo Designer™ applications for use on XBT GT/GK terminals. The service provides: Analysis of the complexity of migration: hardware, software, communication with PLCs, etc. Analysis of the new functional requirements Proposal for migration methodology The possible deliverables include: Simple conversion Full migration of complex machines Migration to SCADA system Standardization process for multiple machines For more information on this service offer, please consult your Regional Sales Office.



VJD SUD TGS V50M

References

All licenses for the Vijeo Designer™ configuration software listed below include a DVD containing:

- Vijeo Designer software, including:
 - Copyright-free *stand-alone* installation of Data Manager
- User documentation in electronic format, including:
 - Online help
 - User manual for the supported targets
 - Setup manual for the different protocols supported
- A multimedia self-learning tool lasting 1 hour 30 minutes in English/French
- The communication protocols described on page 3/15

Note: Vijeo Designer V5.1 supports applications created with any version of Vijeo Designer ≥ V4.5. When updating an earlier application, please contact your Regional Sales Office for Schneider Electric.

Single-station licenses

Designation	License type	Application transfer cable included		Reference	Weight kg
		PC-side port	Terminal side Magelis® XBT/ Magelis® iPC		
Vijeo Designer™ configuration software	Single (1 station)	–	– (1)	VJDSNDTGSV51M	0.125
		USB	XBT GT/GK/GTW Magelis® Smart HMI edition Magelis® Compact iPC HMI edition PC BOX	VJDSUDTGAV51M	0.330

Multistation licenses

Designation	License type	Number of stations (1)	Reference	Weight
Vijeo Designer configuration software	Group	3	VJDGNDTGSV51M	0.125
	Team	10	VJDTNDTGSV51M	0.125
	Facility	Unlimited number of stations on one site	VJDFNDTGSV51M	0.125

Runtime licenses

Designation	Reference	Weight
Vijeo Designer Runtime Software for Magelis iPC	VJDSNRTMPC	0.125

(1) Separate parts: for application transfer cables (PC to Magelis terminal XBT GT/GK/GTW), see page 1/57.

4.1 - Technical appendices

- Certifications for automation products 4/2

4.2 - Index

- Product reference index 4/5

Technical appendices

Certifications for automation products







EC regulations

Some countries require certain electrical components to undergo certification by law. This certification takes the form of a certificate of conformity to the relevant standards and is issued by the official body in question. Where applicable, certified devices must be labelled accordingly. Use of electrical equipment on board merchant vessels generally implies that it has gained prior approval (i.e. certification) by certain shipping classification societies.

Abbrev. name	Certification body	Country
CSA	Canadian Standards Association	Canada
C-Tick	Australian Communication Authority	Australia, New Zealand
GOST	Scientific research institute for GOST standards	CIS, Russia
UL	Underwriters Laboratories	USA
Abbrev. name	Classification society	Country
IACS	International Association of Classification Societies	International
ABS	American Bureau of Shipping	USA
BV	Bureau Veritas	France
DNV	Det Norske Veritas	Norway
GL	Germanischer Lloyd	Germany
LR	Lloyd's Register	UK
RINA	Registro Italiano Navale	Italy
RMRS	Russian Maritime Register of Shipping	CIS, Russia
RRR	Russian River Register	

The tables below provide an overview of the situation as at **01/02/2009** in terms of which certifications (listed next to their respective bodies) have been granted or are pending for our automation products. Up-to-date information on which certifications have been obtained by products bearing the Schneider Electric brand can be viewed on our web site: www.schneider-electric.us/

Product certifications

	Certifications						
							
	UL	CSA	ACA	GOST	Hazardous locations Class 1, div 2 (1)	ATEX	TÜV Rheinland
	USA	Canada	Australia	CIS, Russia	USA, Canada	Europe	
Advantys™ OTB							
Advantys™ STB					FM	Cat. 3 G	
Advantys™ Telefast® ABE 7							
ConneXium™					(2)		
Magelis® iPC, Magelis XBT GTW	(3)			(2)	UL	(2)	
Magelis® XBT GT				(2)	(2)	Cat. 3 G-D	
Magelis® XBT GK					CSA		
Magelis® XBT N/R					CSA/UL	Cat. 3 G-D	
Magelis® XBT RT					CSA/UL	Cat. 3 G-D	
Modicon® M340™					CSA		
Modicon® Momentum™							
Modicon® Premium™				(2)	CSA		
Modicon® Quantum™				(2)	FM (2)		
Modicon® Quantum Safety				(2)	CSA		SIL 2 (4)
Modicon® TSX Micro™							
Phaseo®	(3) (5)						
Twido®	(6)	(6)			CSA/UL (6)		

(1) **Hazardous locations:** According to UL 1604, CSA 22.2 N° 213 and FM 3611, certified products are only approved for use in hazardous locations categorized as Class 1, division 2, groups A, B, C and D, or in non-classified locations.

(2) Depends on product; please visit our web site: www.schneider-electric.us/

(3) North American certification cULus (Canada and USA)

(4) According to IEC 61508. Certified by TÜV Rheinland for integration into a safety function of up to SIL2 level.

(5) Except for power supplies and function modules in the Universal range: UL certification pending

(6) Except for AS-Interface module TWD NOI 10M3; CE only.

Specific certifications









BG	Germany	Safety module TSX DPZ 10D2A (Modicon TSX Micro™) Safety modules TSX PAY 262/282 (Modicon Premium)
SIMTARS	Australia	Modicon TSX Micro automation platform Modicon Premium (PL7) automation platform
AS-Interface®	Europe	Master module TWD NOI 10M3 (Twido) Master module TSX SAZ 10 (Modicon TSX Micro) Master modules TSX SAY 1000 (Modicon Premium)

Technical appendices

Certifications for automation products

EC regulations

Merchant navy certifications

<div style="background-color: #008000; width: 15px; height: 10px; display: inline-block;"></div> Certified <div style="background-color: #90EE90; width: 15px; height: 10px; display: inline-block;"></div> Certification pending	Shipping classification societies							
								
	ABS USA	BV France	DNV Norway	GL Germany	LR UK	RINA Italy	RMRS CIS	RRR CIS
Advantys™ OTB								
Advantys™ STB	(1)							
Advantys™ Telefast® ABE 7								
ConneXium™				(2)				
Magelis® iPC, Magelis XBT GTW								
Magelis® XBT GT								
Magelis® XBT GK								
Magelis® XBT N/R								
Magelis® XBT RT								
Modicon® M340™	(2)	(2)	(2)	(2)	(2)	(2)		
Modicon® Momentum™								
Modicon® Premium™ (3)								
Modicon® Quantum™	(2)	(2)	(2)	(2)	(2)	(2)	(2)	
Modicon® TSX Micro™								
Phaseo®								
Twido®			(4)	(4)	(4)			

(1) Also covers US Navy requirements ABS-NRV part 4.

(2) Depends on product; please visit our web site: www.schneider-electric.us/.

(3) Modicon Premium, also certified by KRS (Korean Register of Shipping).

(4) Except for: Compact bases TWD LC●●40DRF. Extreme base TWD LEDCK1, communication modules 499 TWD 01100, TWD NCO1M and TWD NOI 10M3 and tap junctions TWD XCA ISO/T3RJ.

Certifications pending for I/O extension modules (discrete TM2 D and analog TM2 A).

4

EC regulations

European Directives

The open nature of the European markets assumes harmonization between the regulations set by different European Union member states. European Directives are texts whose aim is to remove restrictions on free circulation of goods and which must be applied within all European Union states. Member states are obligated to incorporate each Directive into their national legislation, while at the same time withdrawing any regulation that contradicts it. Directives - and particularly those of a technical nature with which we are concerned - merely set out the objectives to be fulfilled (referred to as "essential requirements"). The manufacturer is obligated to implement any and all measures to ensure that its products meet the requirements of each Directive that applies to its equipment. As a general rule, the manufacturer certifies compliance with essential requirements of the Directive(s) that apply to its product by applying a CE mark. The CE mark has been applied to our products where applicable.

Significance of the CE mark

- The appearance of a CE mark on a product indicates the manufacturer's certification that the product conforms to the relevant European Directives; this is a prerequisite for placing a product which is subject to the requirements of one or more Directives on the market and for allowing its free circulation within European Union states.
- The CE mark is intended for use by those responsible for regulating national markets.

Where electrical equipment is concerned, conformity to standards indicates that the product is fit for use. Only a warranty by a well-known manufacturer can provide assurance of a high level of quality.

As far as our products are concerned, one or more Directives are likely to apply in each case; in particular:

- The Low Voltage Directive (2006/95/EC)
- The Electromagnetic Compatibility Directive (2004/108/EC)
- The ATEX CE Directive (94/9/EC)

Schneider Electric USA, Inc.

8001 Knightdale Blvd.
Knightdale, NC 27545
Tel: 919-266-3671

19 Waterman Avenue
Toronto, Ontario M4B 1Y2
Tel: 416-752-8020

<http://www.schneider-electric.us/>

The information and dimensions in this catalog are provided for the convenience of our customers. While this information is believed to be accurate, Schneider Electric reserves the right to make updates and changes without prior notification and assumes no liability for any errors or omissions.

Design: Schneider Electric
Photos: Schneider Electric



2010

Magelis® Human/Machine Interfaces

Schneider
Electric