

Installation

MGE™ Galaxy™ 3500 and Smart-UPS™ VT

**Maintenance Bypass, Distribution and
Transformer Cabinet**



American Power Conversion Legal Disclaimer

The information presented in this manual is not warranted by the American Power Conversion Corporation to be authoritative, error free, or complete. This publication is not meant to be a substitute for detailed operational and site specific development plan. Therefore, American Power Conversion Corporation assumes no liability for damages, violations of codes, improper installation, system failures, or any other problems that could arise based on the use of this Publication.

The information contained in this Publication is provided as is and has been prepared solely for the purpose of evaluating data center design and construction. This Publication has been compiled in good faith by American Power Conversion Corporation. However, no presentation is made or warranty, either express or implied, as to the completeness or accuracy of the information this Publication contains.

NO EVENT SHALL AMERICAN POWER CONVERSION CORPORATION BE LIABLE FOR ANY DIRECT, INDIRECT, CONSEQUENTIAL, PUNITIVE, SPECIAL, OR INCIDENTAL DAMAGES (INCLUDING, WITHOUT LIMITATION, DAMAGES FOR LOSS OF BUSINESS, CONTRACT, REVENUE, DATA, INFORMATION, OR BUSINESS INTERRUPTION) RESULTING FROM, ARISING OUT, OR IN CONNECTION WITH THE USE OF, OR INABILITY TO USE THIS PUBLICATION OR THE CONTENT, EVEN IF AMERICAN POWER CONVERSION CORPORATION HAS BEEN EXPRESSLY ADVISED OF THE POSSIBILITY OF SUCH DAMAGES. AMERICAN POWER CONVERSION CORPORATION RESERVES THE RIGHT TO MAKE CHANGES OR UPDATES WITH RESPECT TO OR IN THE CONTENT OF THE PUBLICATION OR THE FORMAT THEREOF AT ANY TIME WITHOUT NOTICE.

Copyright, intellectual, and all other proprietary rights in the content (including but not limited to software, audio, video, text, and photographs) rests with American Power Conversion Corporation or its licensors. All rights in the content not expressly granted herein are reserved. No rights of any kind are licensed or assigned or shall otherwise pass to persons accessing this information.

This Publication shall not be for resale in whole or in part.

Table of Contents

IMPORTANT SAFETY INSTRUCTIONS SAVE THESE INSTRUCTIONS	1
Specifications	2
SBP10K15F and SBP20K30F	2
SBP10K30F-DP, SBPXF10K30F, and XFM10K30F	2
SBPXF10K30G and XFM10K30G	2
Physical	3
Environmental	3
Torque Value	3
Product Overview	4
Maintenance Bypass Cabinet	4
Maintenance Bypass with Distribution	5
Transformer	6
Transformer with Maintenance Bypass	7
Level the Cabinet	8
Floor Anchoring (if applicable)	9
Anchor the Cabinet to the Floor	9
Prepare for Cables	10
Create Knockouts for Cable Access	10
Run the Cables	12
Cable Entry through I/O Cabinet	12
Top Cable Entry	13
Bottom Cable Entry	14
Connect Power Cables	15
Maintenance Bypass	15
Maintenance Bypass with Distribution	16

Transformer	18
Transformer with Maintenance Bypass	18
Connect the Communication Cables	19

IMPORTANT SAFETY INSTRUCTIONS

SAVE THESE INSTRUCTIONS



WARNING:

ALL safety instructions in the Safety Sheet (990-2940 or 990-2822) must be read, understood, and followed when you install the UPS system. Failure to do so could result in equipment damage, serious injury, or death.



Caution:

All electrical power and power control wiring must be installed by a qualified electrician, and must comply with local and national regulations for maximum power rating.



Caution:

Operation and maintenance must only be performed by qualified personnel



Note:

Refer to the UPS Receiving and Unpacking sheet (990-2940 for MGE Galaxy 3500 and 990-1747 for Smart-UPS VT) to determine the space requirements for the maintenance bypass. Consult local codes for any additional requirements. Ideally, install the maintenance bypass in a location close to the UPS.

Specifications

SBP10K15F and SBP20K30F

Electrical	10-15 kVA	20-30 kVA
Nom. input voltage	208 V 4W+GND	208 V 4W+GND
Nom. output voltage	208 V 4W+GND	208 V 4W+GND
Circuit breaker rating	60 A	125 A
Wiring (only use copper conductors suitable for at least 75 °C)		
Maximum cable size	70 mm ² (2/0 AWG)	70 mm ² (2/0 AWG)
System output/ UPS output cable	25 mm ² (4 AWG)	50 mm ² (1 AWG)
System input/UPS input cable	25 mm ² (4 AWG)	50 mm ² (1 AWG)

SBP10K30F-DP, SBPXF10K30F, and XFM10K30F

Electrical	10-30 kVA
Nom. input voltage	208 V 4W+GND
Nom. output voltage	208 V 4W+GND
Circuit breaker rating	125 A
Wiring (only use copper conductors suitable for at least 75 °C)	
Maximum cable size	70 mm ² (2/0 AWG)
System output/ UPS output cable	50 mm ² (1 AWG)
System input/UPS input cable	50 mm ² (1 AWG)

SBPXF10K30G and XFM10K30G

Electrical	10-30 kVA
Nom. output voltage	480 V 3W+GND
Nom. input voltage	208 V 4W+GND
Circuit breaker rating	50 A
Wiring (only use copper conductors suitable for at least 75 °C)	
Maximum cable size	70 mm ² (2/0 AWG)
System output/ UPS output cable	50 mm ² (1 AWG)
System input/UPS input cable	13 mm ² (6 AWG)/50 mm ² (1 AWG)

Physical

Cabinet	Shipping weights kg (lbs)	Weights kg (lbs)	Height mm (in)	Width mm (in)	Depth mm (in)
Maintenance bypass	156 (344)	122 (268)	1487 (58.5)	352 (14)	837 (33)
Maintenance bypass with distribution	189 (416)	154 (340)	1487 (58.5)	352 (14)	837 (33)
Transformer	314 (692)	279 (616)	1487 (58.5)	352 (14)	837 (33)
Transformer with maintenance bypass	365 (804)	330 kg (728)	1487 (58.5)	352 (14)	837 (33)

Environmental

Operating environment	Indoor use only, protect from water and conductive contaminants
Operating temperature	0° to 40 °C (32° to 104 °F)
Humidity	0 to 95%, non-condensing

Torque Value

Terminal blocks	6.89 Nm (61 lbs in)
Busbars M6	11.3 Nm (100 lbs in)

Product Overview

Maintenance Bypass Cabinet

Front View

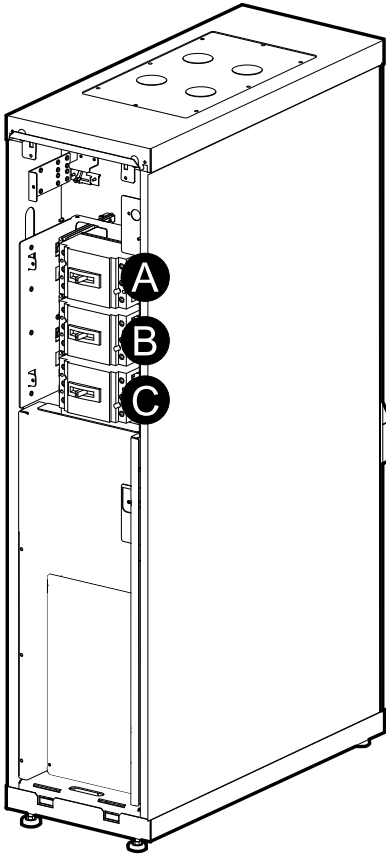

Rear View

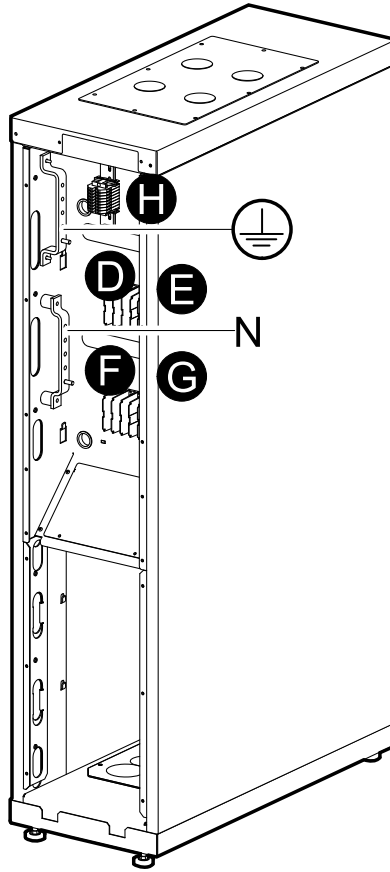

- A. Q1 input breaker
- B. Q3 maintenance bypass breaker. A Philips screwdriver is required to unlock Q3
- C. Q2 output breaker
- D. Mains input
- E. Critical load
- F. UPS output
- G. UPS input
- H. Control terminal block

Diagram

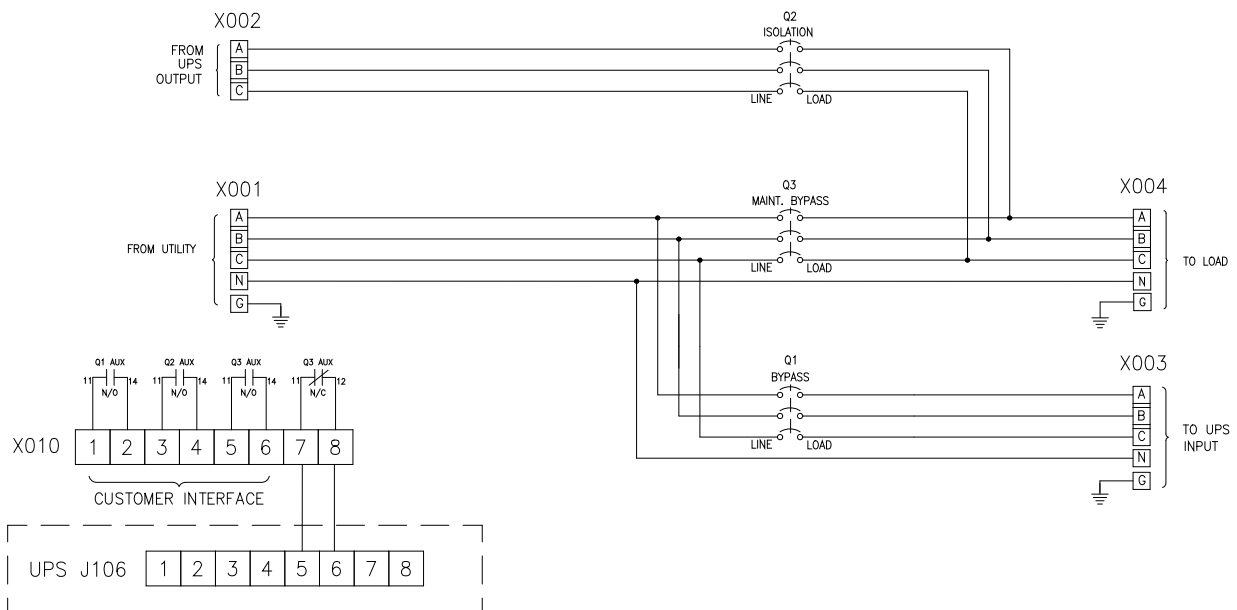

Maintenance Bypass with Distribution

Front View

Rear View

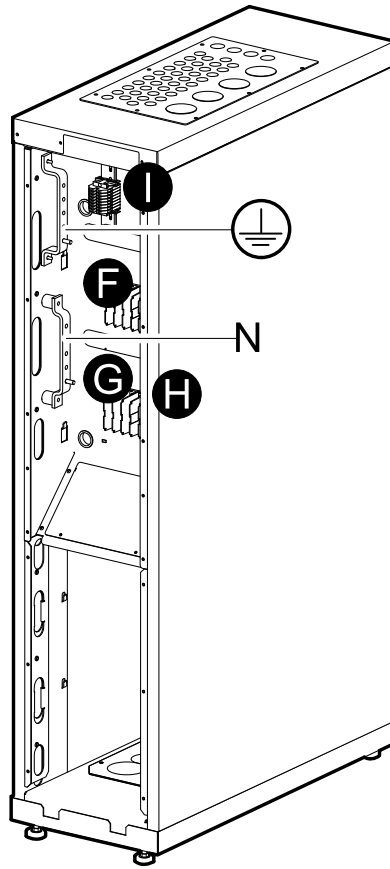
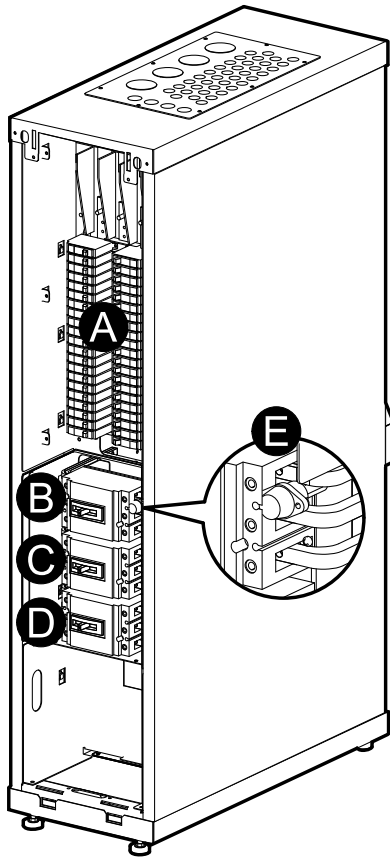

- A. Distribution panel
- B. Q1 input breaker
- C. Q3 maintenance bypass breaker. A Philips screwdriver is required to unlock Q3
- D. Q2 output breaker
- E. Control fuse
- F. Mains input
- G. UPS output
- H. UPS input
- I. Control terminal block

Diagram

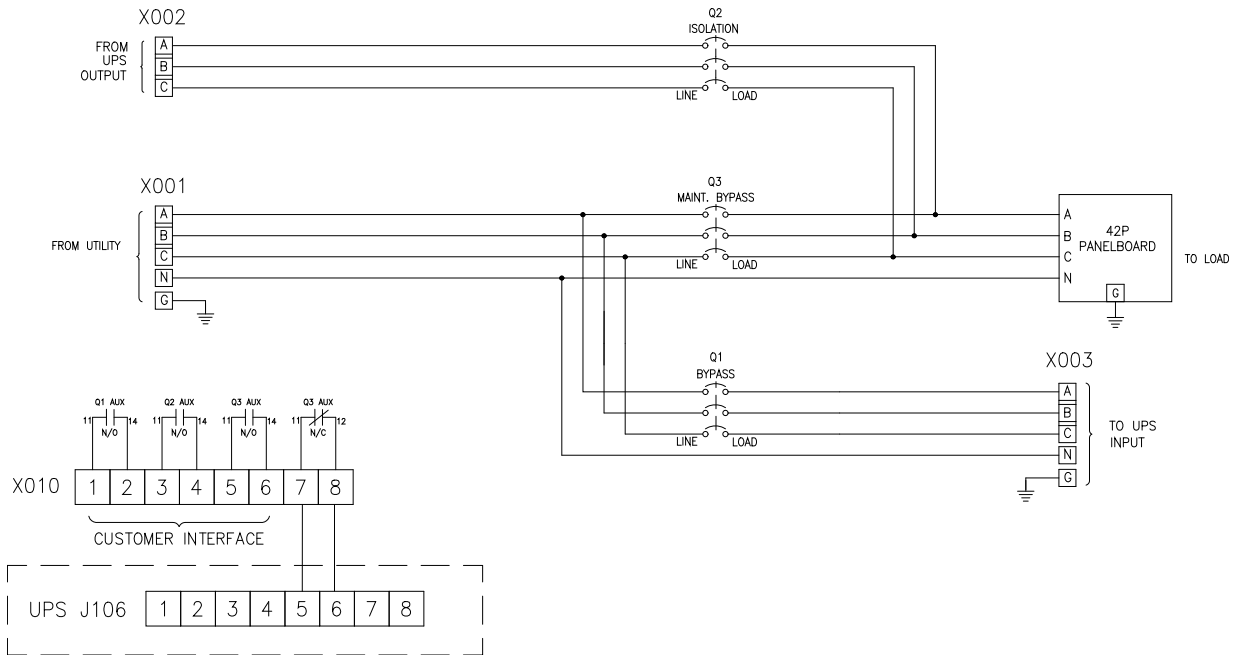

Transformer

Front View

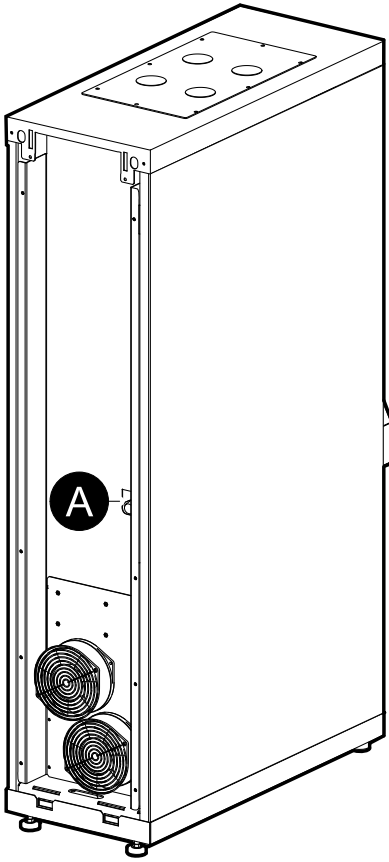

Rear View

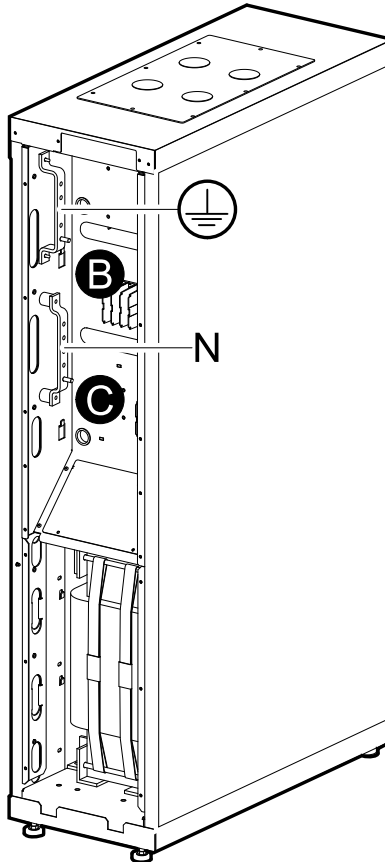

- A. Control fuse
- B. Mains input
- C. UPS input

Diagram

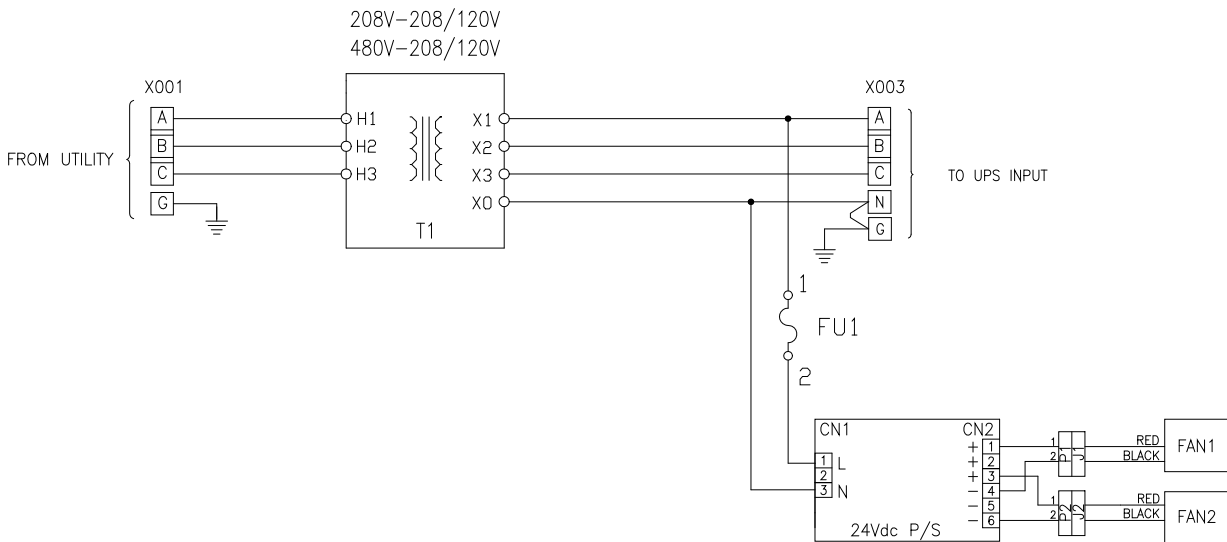

Transformer with Maintenance Bypass

Front View

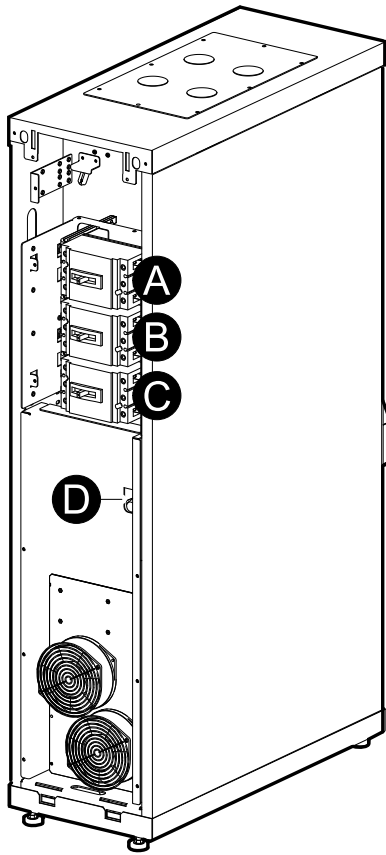

Rear View

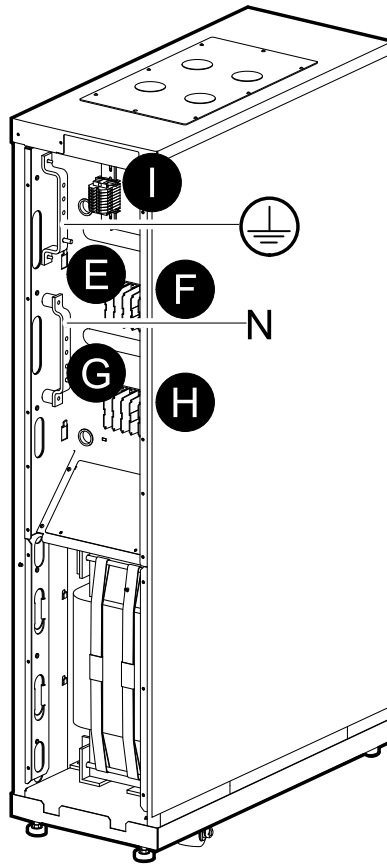

- A. Q1 input breaker
- B. Q3 maintenance bypass breaker
- C. Q2 output breaker
- D. Control fuse
- E. Mains input
- F. Critical load
- G. UPS output
- H. UPS input
- I. Control terminal block

Diagram

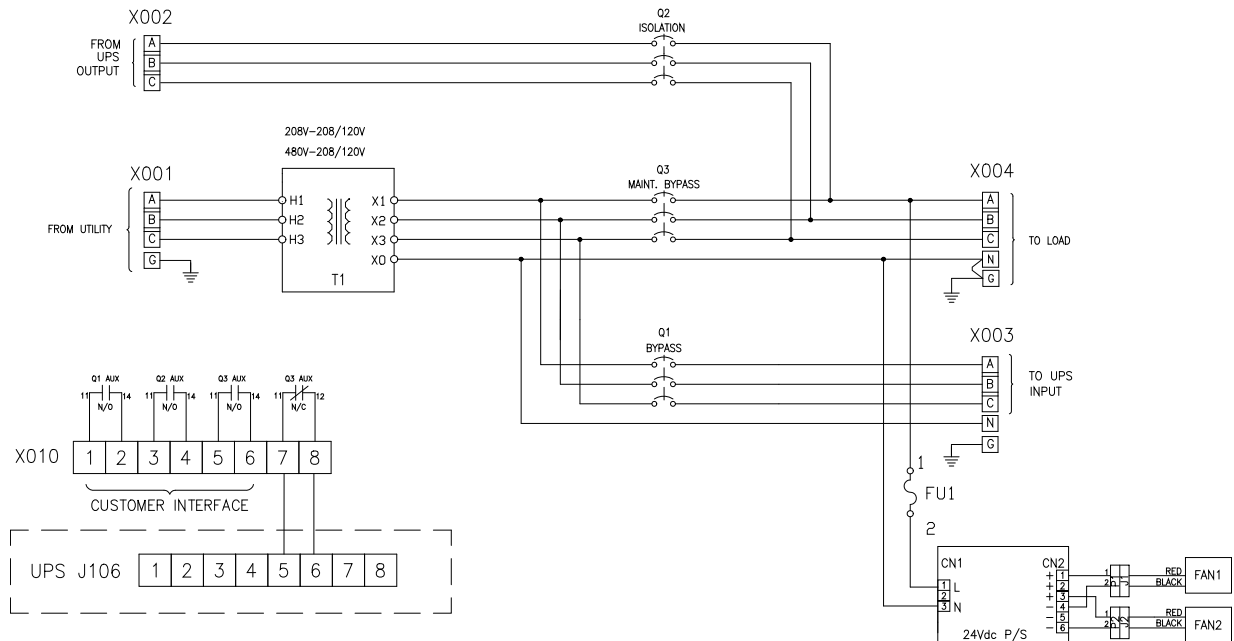

Level the Cabinet



WARNING: The system must be installed on a level floor. The leveling feet will stabilize the cabinet, but will not account for a badly sloped floor.

1. Take the 13/14 mm wrench attached to the pallet.
2. Adjust the four leveling feet and ensure that the system is level.

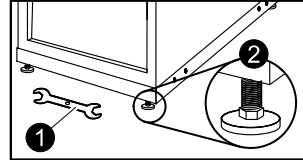

Note: Do not move the cabinet after the leveling feet have been lowered.

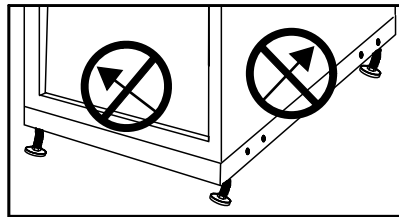

Floor Anchoring (if applicable)

Anchor the Cabinet to the Floor



Note: Floor anchoring bolts are not provided with the UPS. Purchase the bolts locally (minimum size: M8). Follow the specifications given by the manufacturer of the floor anchoring system when bolting the UPS system to the floor.

1. Install the L-shaped floor anchoring brackets (reuse the two transport brackets) and secure with the M6 screws and nuts (provided).
2. Drill two to six holes in the floor for each bracket and attach these with bolts.

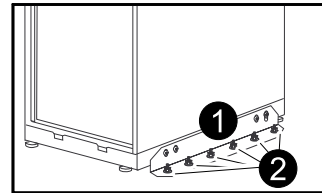

Prepare for Cables



Note: All external cable connections with the UPS and mains must be made on-site. External cables are not supplied with the shipment.



Note: All control wire connections between the UPS and the cabinet must be made on-site. Control wires for Q3 auxiliary are supplied with the shipment.



Note: Internal cable connections for adjacent cabinet configurations are supplied with the auxiliary cabinet.

Create Knockouts for Cable Access

1. Remove the front panel.
2. Remove the top or bottom cover.
3. Use a knockout punch to create appropriate-sized holes for the cables/conduits in either the top or bottom cover of the cabinet.

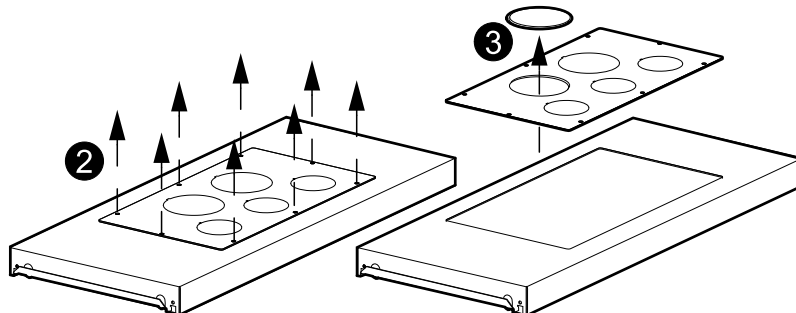

4. Remove the right side panel.
5. Remove the right inner panel.
6. Install conduits (if applicable) and re-install all the covers.

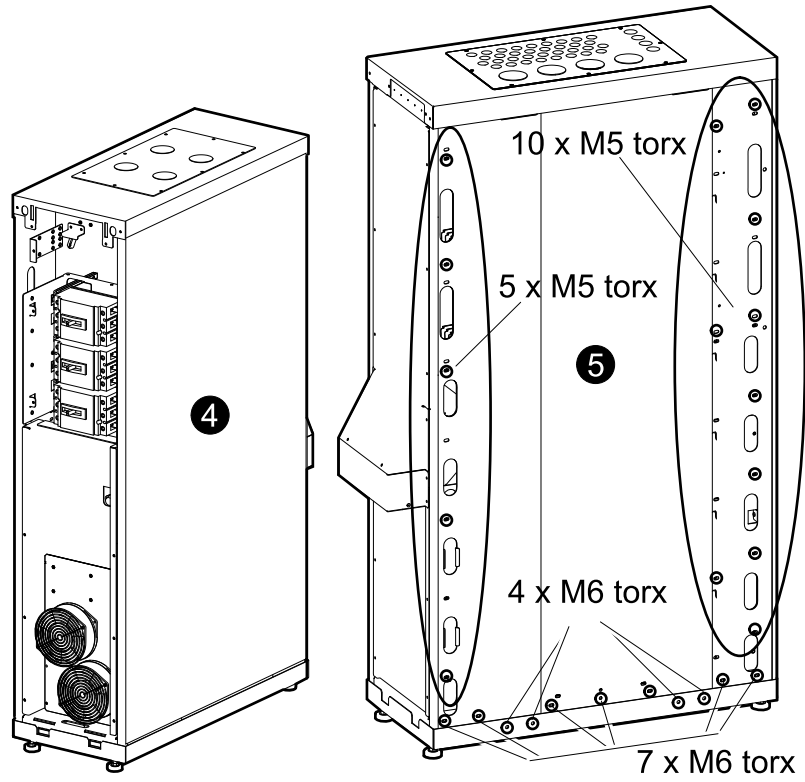

Run the Cables

Cable Entry through I/O Cabinet



Note: Bottom cable entry is not applicable to cabinets with transformers.

1. Remove the upper rear cover.
2. Remove the top cover of the I/O cabinet.
3. Remove the bottom cover of the I/O cabinet (this one will not be reinstalled).
4. Route the cables through the I/O cabinet to the cable connection area.
5. Re-install the top cover of the I/O cabinet.

Rear View

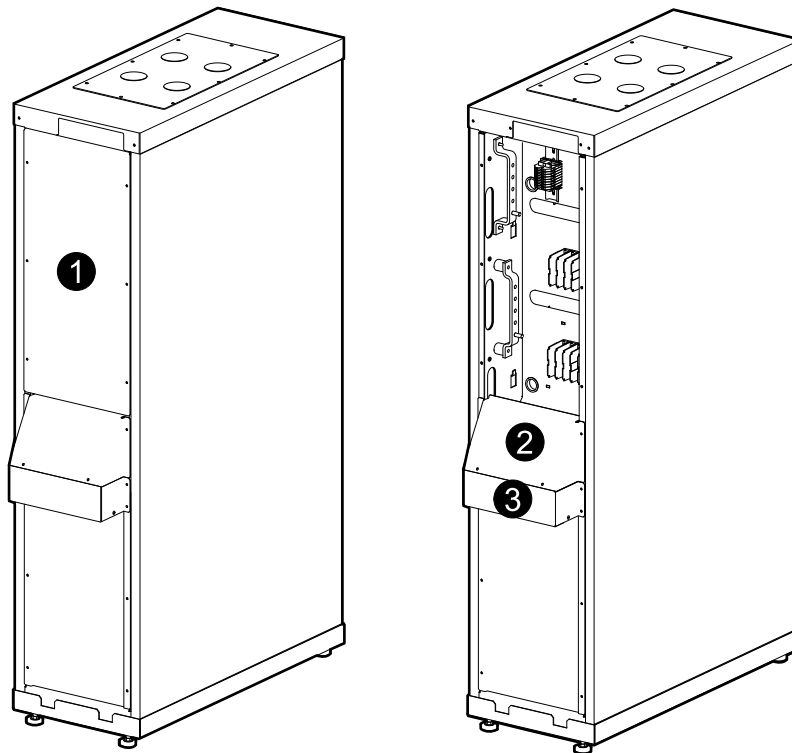

Top Cable Entry

1. Remove the upper rear cover.
2. Run the cables through the top cover to the cable connection area.
3. Re-install the upper rear cover.

Rear View

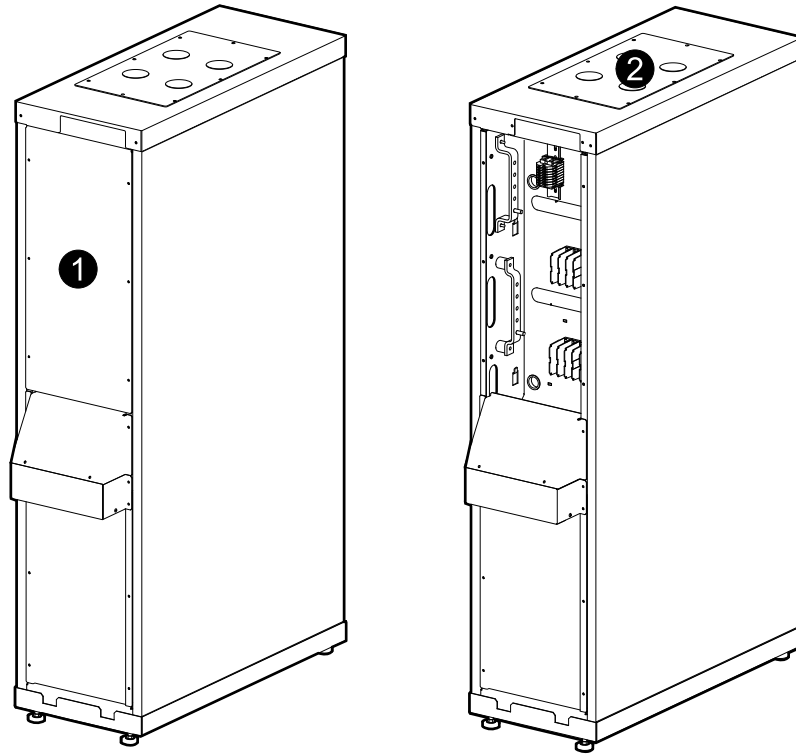

Bottom Cable Entry

1. Remove the upper rear cover.
2. Remove the top cover of the I/O cabinet.
3. Remove the bottom cover of the I/O cabinet.
4. Remove the plate which blocks the cable access from the bottom.
5. Route the cables through the bottom to the cable connection area.
6. Re-install the I/O cabinet.

Rear View

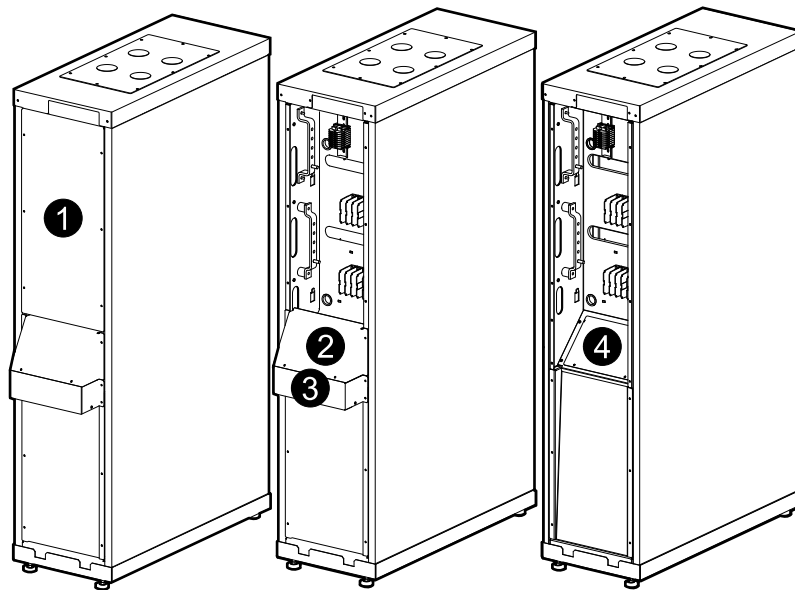

Connect Power Cables

Maintenance Bypass

1. Connect the mains input cables (L1, L2, L3, N, G) to the mains input terminals (X001), and the ground and neutral busbars.
2. Connect the UPS input cables (L1, L2, L3, N, G) from the UPS input terminals (X003), and the ground and neutral busbars.
3. Connect the UPS output cables (L1, L2, L3, G) from the UPS output terminals (X002), and the ground and neutral busbars.
4. Connect the critical load (L1, L2, L3, N, G) to the load terminals (X004), and the ground and neutral busbars.

Rear View

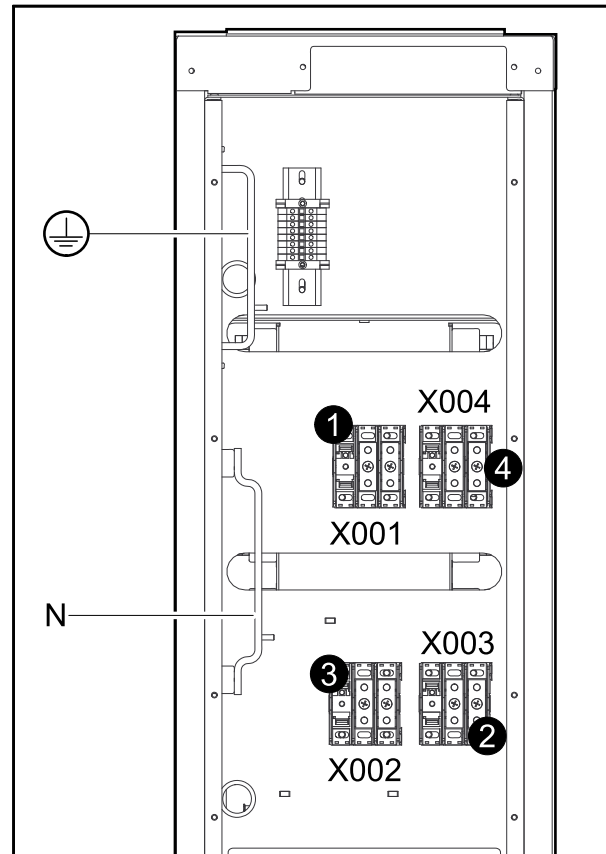

Maintenance Bypass with Distribution

Rear View

Rear View

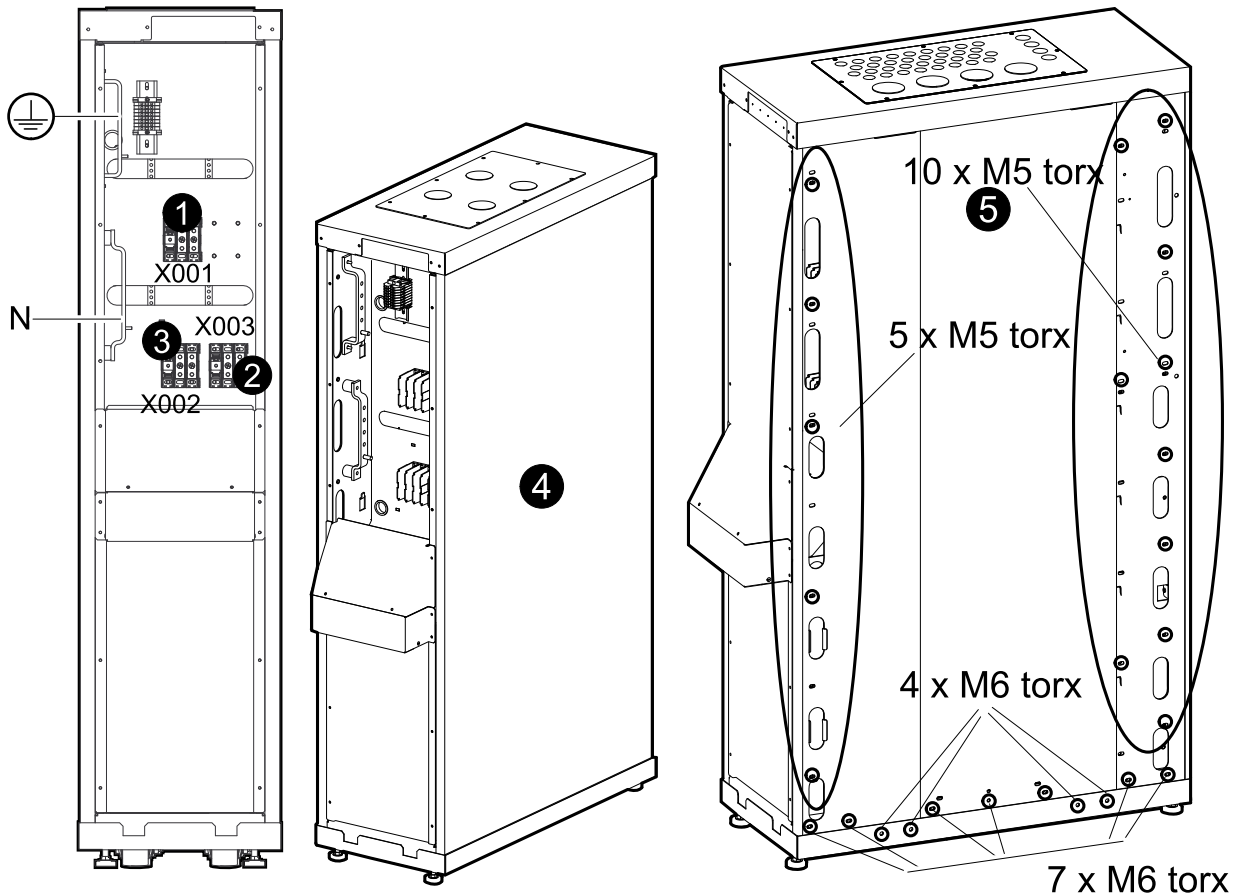

1. Connect the mains input cables (L1, L2, L3, N, G) to the mains input terminals (X001), and the ground and neutral busbars.
2. Connect the UPS input cables (L1, L2, L3, N, G) from the UPS input terminals (X003), and the ground and neutral busbars.
3. Connect the UPS output cables (L1, L2, L3, G) from the UPS output terminals (X002), and the ground and neutral busbars.
4. Remove the right side panel (seen from the rear).
5. Remove the marked screws and remove the right inner cover (seen from the rear).
6. Loosen the six screws and remove the inner cover.
7. Connect the L1, L2, L3, N, G cables from the critical load to the required distribution modules.
8. Connect the distribution modules to the distribution panel and route the cables through the routing window just below the distribution panel.

Front View

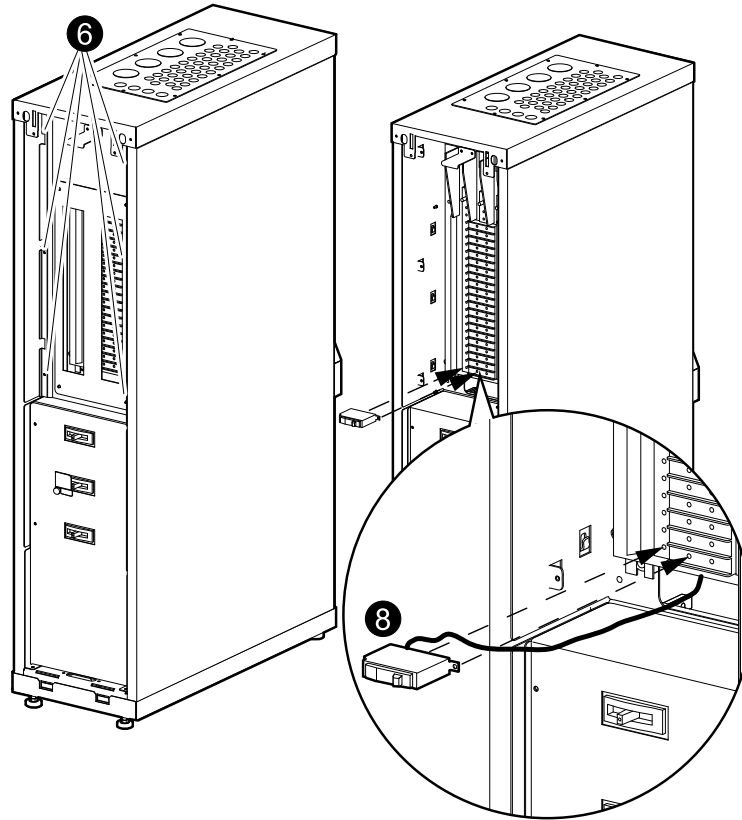

9. Connect N and G to the busbars and run L1, L2, L3, through the top or bottom.
10. Re-install all covers.

Rear View

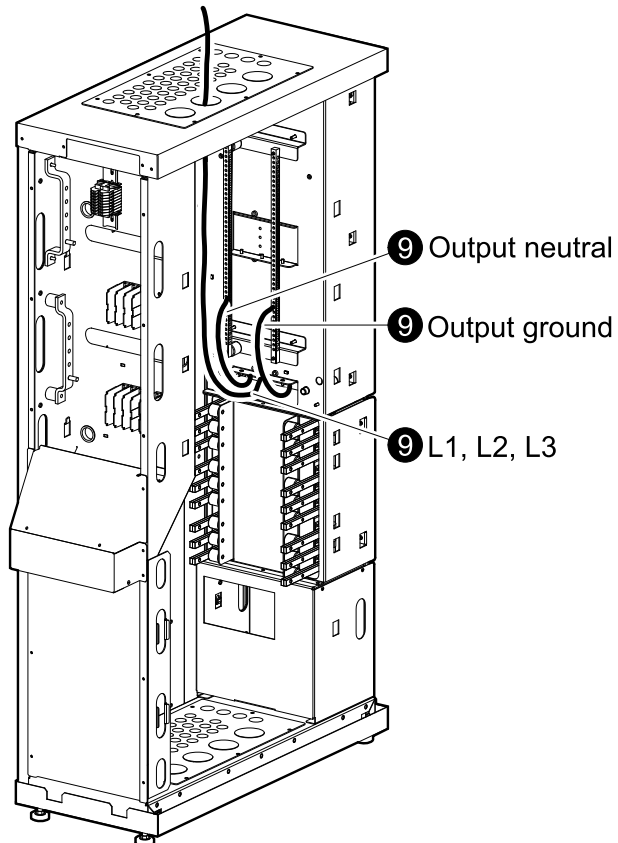

Transformer

1. Connect the mains input cables (L1, L2, L3, G) to the mains input terminals (X001), and the ground and neutral busbars.
2. Connect the UPS input cables (L1, L2, L3, N, G) from the UPS input terminals (X003), and the ground and neutral busbars.
3. Reinstall the top cover of the I/O cabinet.

Rear View

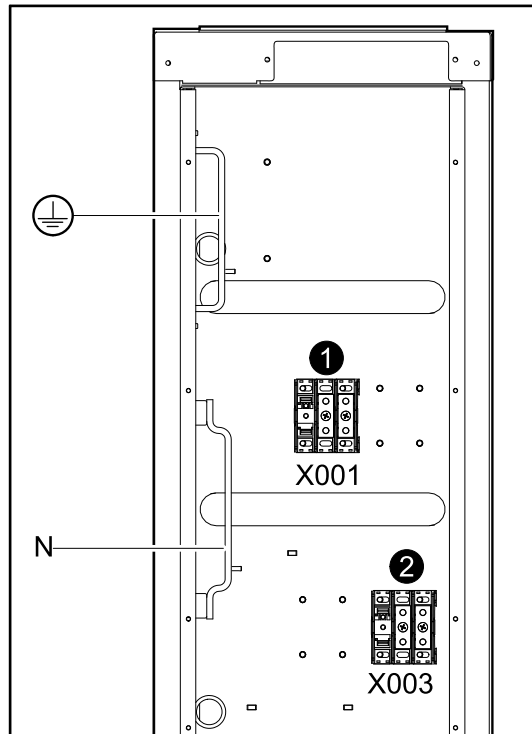

Transformer with Maintenance Bypass

1. Connect the mains input cables (L1, L2, L3, G) to the mains input terminals (X001), and the ground and neutral busbars.
2. Connect the UPS input cables (L1, L2, L3, N, G) from the UPS input terminals (X003), and the ground and neutral busbars.
3. Connect the UPS output cables (L1, L2, L3, G) from the UPS output terminals (X002), and the ground and neutral busbars.
4. Connect the critical load (L1, L2, L3, N, G) to the load terminals (X004), and the ground and neutral busbars.
5. Reinstall the top cover of the I/O cabinet.

Rear View

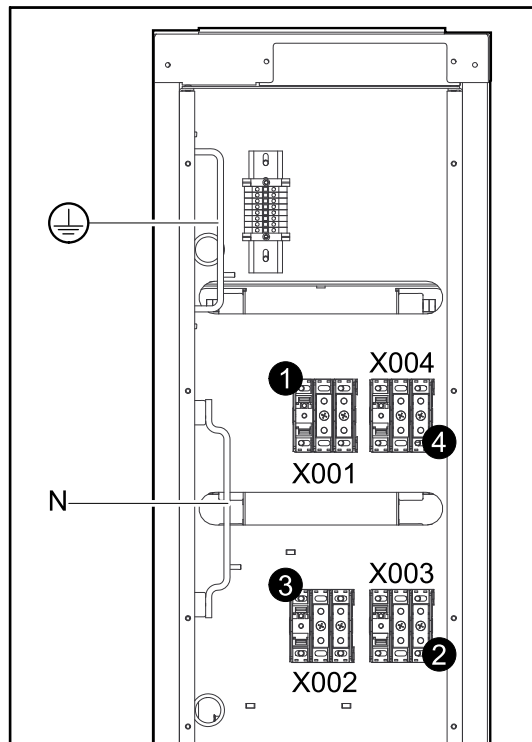

Connect the Communication Cables



Note: Control wires for Q3 auxiliary are supplied with the shipment.



Note: The transformer has no communication wiring.

1. Route the communication cables through the top, bottom, or I/O cabinet.
2. Connect the wires between the UPS (J106 port 5) from the maintenance bypass (X010 port 7 on the control terminal block).
3. Connect the wires between the UPS (J106 port 6) from the maintenance bypass (X010 port 8 on the control terminal block).

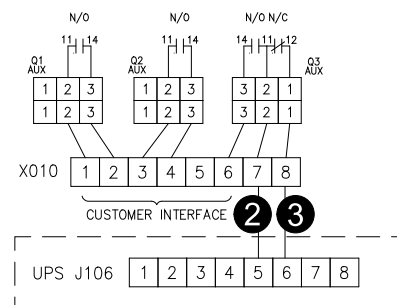
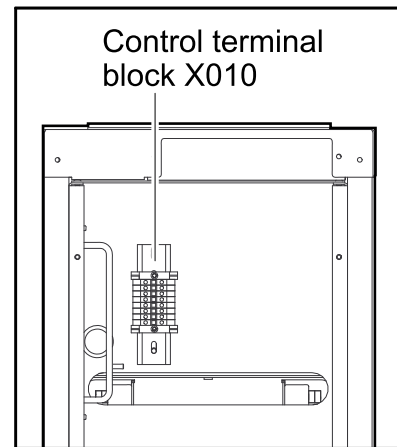

Worldwide Customer Support

Customer support is available at no charge via e-mail or telephone. Contact information is available at www.apc.com/support/contact

© APC by Schneider Electric. APC and the APC logo are owned by Schneider Electric Industries S.A.S., American Power Conversion Corporation, or their affiliated companies. All other trademarks are property of their respective owners.