

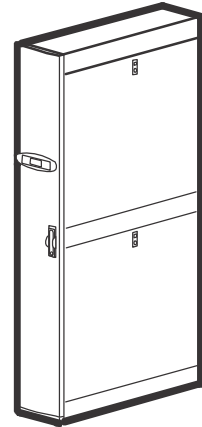

# Installation

## Modular Power Distribution Unit 480V;415V with Auto-transformer PDPM288G6H



### SAVE THESE INSTRUCTIONS!

#### ⚠️ ⚠️ DANGER

##### HAZARD OF ELECTRIC SHOCK

- Electrical equipment must be installed, operated, serviced, and maintained only by qualified personnel. To remove a Power Distribution Module:
  - Turn off all power supplying the equipment and perform appropriate lockout/tagout procedures before installing or removing the Power Distribution Module.
- OR
- If a Symmetra PX UPS is providing power to the Modular PDU, place the UPS into battery operation (to reduce fault current) before removing the Power Distribution Module. To place the UPS into battery operation, see the UPS Operation Manual.
- The PDU must be installed in accordance with the National Electrical Code or the Canadian Electrical Code and all applicable local codes.
- Service access areas are locked with a Red Key. The Red Keys must remain under the control of qualified service personnel.
- Wear appropriate personal protection equipment (PPE) when performing maintenance on this PDU.

Failure to follow these instructions will result in death or serious injury.

#### ⚠️ WARNING

##### TIP HAZARD

This equipment is easily tipped. Use extreme caution when unpacking and moving. Failure to follow these instructions can result in death, serious injury, or equipment damage.

#### ⚠️ CAUTION

##### DEBRIS HAZARD

Remove cover plates from the unit before cutting holes or removing knockout plugs for cable access. Metal debris can cause serious equipment damage. A metal punch can be used to make the holes in the plates.

Failure to follow these instructions can result in injury or equipment damage.

## Connect and Level

The equipment must be installed on a level floor. The leveling feet will stabilize the enclosure, but will not account for a badly sloped floor. If the PDU is on a raised-tile floor, verify that it is properly aligned with the tiles.

- 1 Align the enclosures.
- 2 Lower the four levelling feet. Use a 17mm wrench to adjust the levelling feet.

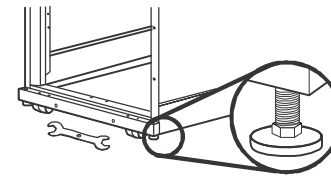

- 3 Do not move the enclosure after the leveling feet have been lowered.

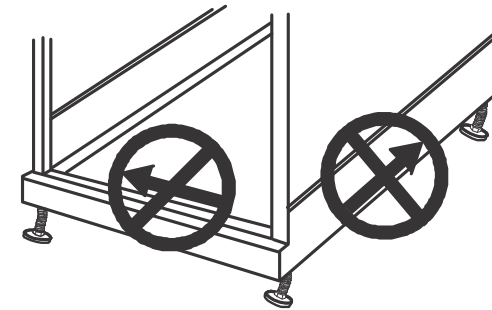

- 4 Turn the joining brackets and secure with a screw to connect the enclosures. **NOTE:** Joining brackets are located on the front and rear of the PDU.

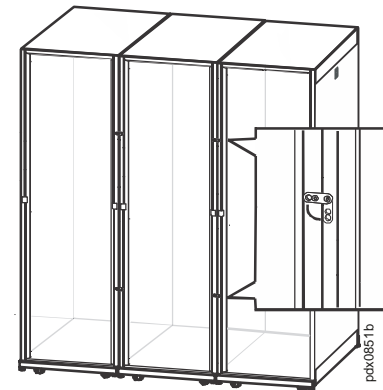

## Install Power Cables

- 1 Open the rear door of the PDU.

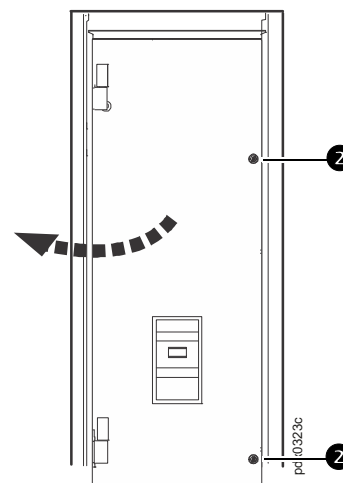

- 2 Open the top interior door to expose the input breaker.

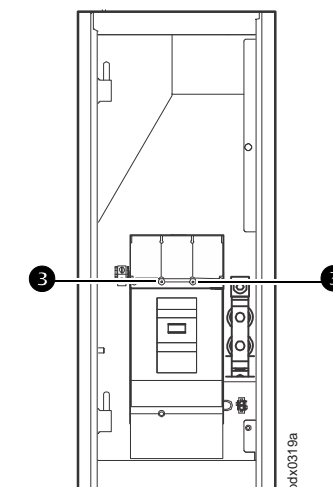

- 3 Remove the screws from the plastic phase separator.

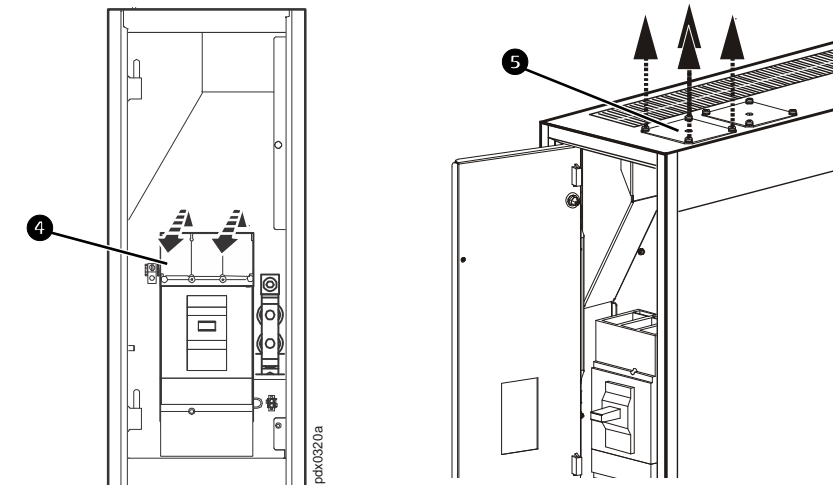

- 4 Grip the phase separator and pull it straight toward you. Do not wiggle side-to-side or up-and-down. The plastic may break.

- 5 Loosen the four screws and remove the rear top plate. Cut or punch a hole in the plate for power cable conduit.

### NOTICE

Refer to the label on your PDU for input cable termination torque requirements.

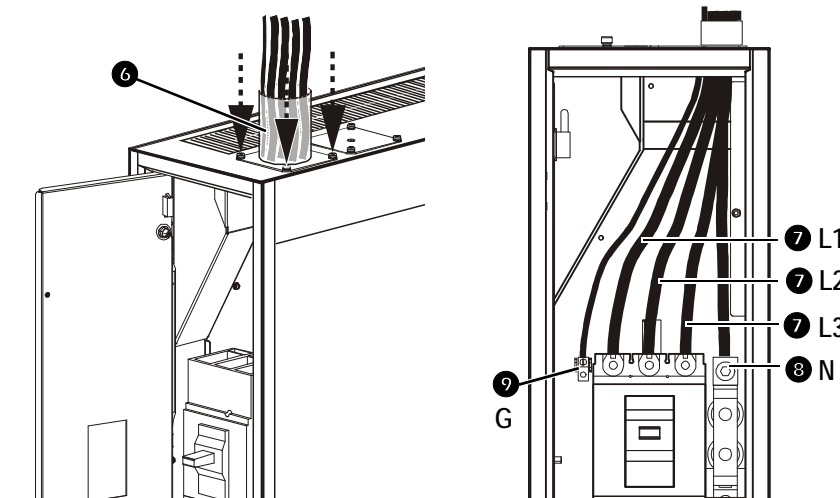

- 6 Reinstall the plate with the conduit attached.

- 7 Connect the phase (L1, L2, L3) cables to the Input breaker

- 8 Connect the neutral (N) cable.

- 9 Connect the ground (G) cable.

- 10 Reinstall the plastic phase separator (from steps 3 and 4).

- 11 Close the small interior top door (from step 2), and then close the rear door, of the PDU.

## User Input/Output Contacts

Connect contact wires from external signaling, alarming, and sensing devices to the interface board to allow the PDU microprocessor to monitor these devices.

- 1 Open the front door of the PDU.
- 2 The interface board is located on the underside of the top plate above the PDMs

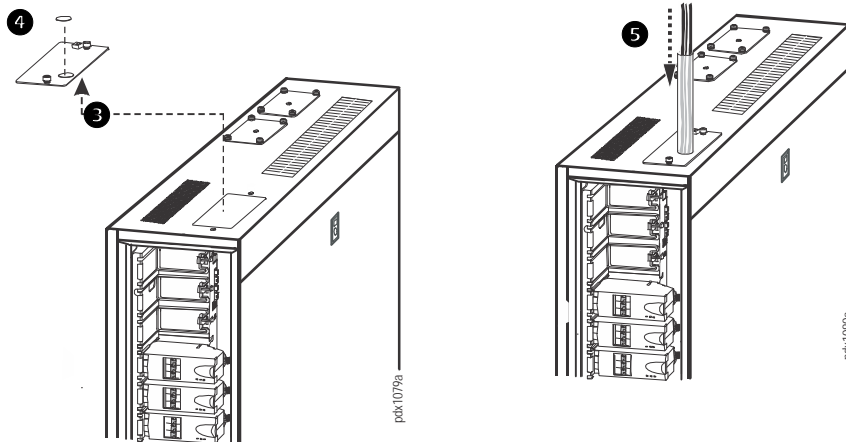
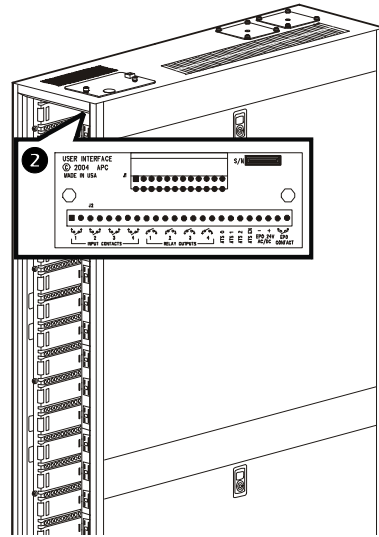

- 3 Loosen the two captive screws to remove the top plate.
- 4 Punch out the 64 mm (3/4 in.) knockout plug in the top plate.
- 5 Install conduit containing contact wires from external devices through the knockout plug.

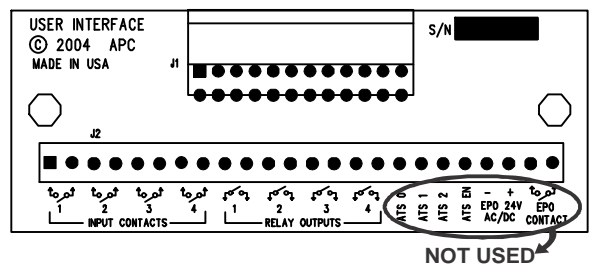

Make connections to the appropriate terminals on the interface board.

### NOTES:

1. Input Contacts are Normally Open. Output Contacts: SPST N/O, 1A@30VDC.
2. AS0, ATS1, ATS2, ATSEN, ATS EN, the +/- EPO 24V AC/DC positions, and both EPO CONTACT positions are reserved and not available.
3. Wiring: 18 AWG to 24 AWG is recommended.

## Connect the Communication Cable

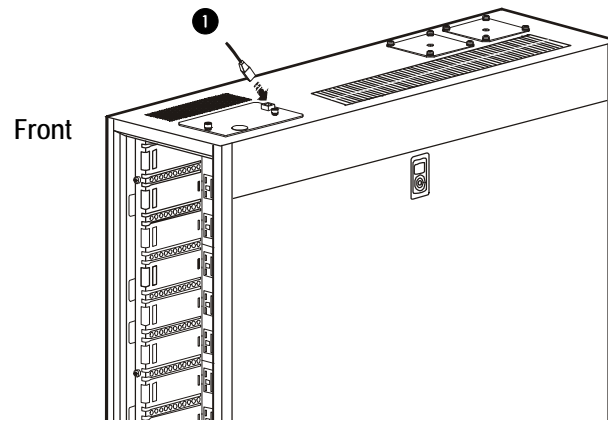

- 1 Connect the network cable to the RJ-45 port on top of the PDU.
- 2 Connect the other end of the network cable to your StruxureWare or local area network port.

## Install a Power Distribution Module

See the Power Distribution Module Installation Sheet shipped with each module or click on the APC by Schneider Electric logo at the bottom of the home page online at [www.schneider-electric.com](http://www.schneider-electric.com) to search for power distribution module installation information.

## Specifications

### AC Input

Nominal voltage	480Y/277 V, 3W + N + G
Frequency	60 Hz
Input circuit breaker	400 A
Maximum continuous current	320 A

### AC Output

Nominal voltage	415Y/240 V, 3W + N + G 240 V, 1W + N + G
Maximum continuous current	370 A
Full load rating	266 kW @ 415 V 3 PH
Power distribution module (PDM)	415Y/240V, 3-pole modules
Power distribution poles available	72
Maximum number of PDMs	24
Output cable connections	TC-ER (Tray cable - exposed runs)
Output cable lengths	Various, based on standard PDMs

### Auto-transformer

Size and type	288 kVA
Type	Wye
Input voltage	480Y/277 V
Input current	346 A
Output voltage	415Y/240 V
Output current	400 A
Thermal sensing	180 NC

### Auto-transformer

Weight	275 kg (606 lb)
Efficiency	> 99.6 %
Frequency	60 Hz
Noise	< 50 db @ 1 meter

### 400 A, 75°C Conductors

Wiring System	Copper
3 CCC, 30°C Ambient	Ø&N = (2) 4/0 AWG G = 3 AWG
4 CCC, 30°C Ambient	Ø&N = (2) 250 kcmil G = 3 AWG

### NOTES:

CCC = Current-Carrying Conductors	AWG = American Wire Gauge
kcmils = MCM = Thousands of Circular Mills	Ø = Phase conductor
(2) = Two conductors per terminal	N = Neutral conductor
	G = Ground (Equipment Grounding) conductor

### Environmental Compliance

Operating Environment	Protected from water and conductive contaminants
Temperature	Operating: 0 to 30°C (32 to 86°F) Storage: 0 to 45°C (32 to 113°F)
Humidity	Operating: 0 to 95%, non-condensing Storage: 0 to 95%, non-condensing
Elevation	1000 m (3,000 ft)
Full load heat loss at nominal mains:	3616BTU/H
Certification	UL and cUL

**NOTE:** Circuit breakers and conductor ampacity are derated in accordance with the National Electrical Code.

## Regulatory Agency Approval

This equipment has been tested and found to comply with the limits for a Class A digital device, pursuant to Part 15 of the FCC Rules. These limits are designed to provide reasonable protection against harmful interference when the equipment is operated in a commercial environment. This equipment generates, uses, and can radiate radio frequency energy and, if not installed and used in accordance with the Installation Guide, may cause harmful interference to radio communications. Operation of this equipment in a residential area is likely to cause harmful interference, in which case the user will be required to correct the interference at his own expense.

*This Class A digital apparatus complies with Canadian ICES-003.*

*Cet appareil numérique de la classe A est conforme à la norme NMB-003 du Canada.*

This is a Class A Product. In a domestic environment this product may cause interference, in which case the user may be required to take adequate measures.

## Worldwide Customer Support

Customer support is available at  
[www.schneider-electric.com/support](http://www.schneider-electric.com/support).