

MGE™ Galaxy™ 7000

160 – 500 kVA

User manual

Single UPS

Integrated parallel UPS

Parallel UPS with SSC

Frequency converters

Static-switch cabinet



Introduction

Thank you for selecting an APC by Schneider Electric product to protect your electrical equipment.

The **MGE™ Galaxy™ 7000** range has been designed with the utmost care.

We recommend that you take the time to read this manual to take full advantage of the many features of your **UPS (Uninterruptible Power Supply)**.

APC by Schneider Electric pays great attention to the environmental impact of its products.

Measures that have made **MGE™ Galaxy™ 7000** a reference in environmental protection include:

- ▶ the eco-design approach used in product development,
- ▶ the elimination of harmonic disturbances reinjected into the AC source,
- ▶ production in an ISO 14001 certified factory,
- ▶ recycling of the **MGE™ Galaxy™ 7000** at the end of its service life.

To discover the entire range of APC by Schneider Electric products and the options available for the **MGE™ Galaxy™ 7000** we invite you to visit our web site at: www.apc.com, or contact your local representative.
APC by Schneider Electric.

All products in the **MGE™ Galaxy™ 7000 range** are protected by patents. They implement original technology not available to competitors of APC by Schneider Electric.

To take into account evolving standards and technology, equipment may be modified without notice. Indications concerning technical characteristics and dimensions are not binding unless confirmed by APC by Schneider Electric.

This document may be copied only with the written consent of Schneider Electric or its affiliated companies. Authorised copies must be marked **MGE™ Galaxy™ 7000** user manual no. 3402084700".

Pictograms

Document



Danger, these instructions are imperative



Audio signal



Information, advice, help.



LED off



Visual indication



LED flashing



Action



LED on

Safety

Safety rules

Safety of persons

The UPS must be installed in a room with restricted access, in compliance with standard IEC 60364-4-42.

Only qualified personnel are authorised to enter this restricted access room.

A UPS has its own internal power source (the battery). Consequently, the power outlets may be energised even if the UPS is disconnected from the AC-power source.



Dangerous voltage levels are present within the UPS. It should be opened exclusively by qualified service personnel. The UPS must be properly earthed.

The battery supplied with the UPS contains small amounts of toxic materials. Caution, replacement of the battery by a battery of the wrong type can result in an explosion.

To avoid accidents, the instructions below must be observed.

- ▶ **Never operate the UPS if the ambient temperature and relative humidity are higher than the levels specified in the documentation.**
- ▶ **Never burn the battery (risk of explosion).**
- ▶ **Do not attempt to open the battery (the electrolyte is dangerous for the eyes and skin).**
- ▶ **Comply with all applicable regulations for the disposal of the battery.**
- ▶ **Caution, wait for five minutes before opening the UPS to allow the capacitors to discharge.**
- ▶ **Caution, there is high leakage current: the earthing conductor must be connected first and disconnected last.**
- ▶ **The product must be installed on a non-inflammable surface (e.g. concrete).**
- ▶ **Caution: battery replacement must be carried out by qualified personnel.**
- ▶ **Isolate the UPS before working on the circuits upstream**
- ▶ **The UPS can only be used in a controlled environment.**

Product safety

- ▶ Protection (circuit breaker/switch disconnecter) must be installed upstream and be easily accessible.
- ▶ Never install the UPS near liquids or in an excessively damp environment.
- ▶ Never let a liquid or foreign body penetrate inside the UPS.
- ▶ Never block the ventilation grates of the UPS.
- ▶ Never expose the UPS to direct sunlight or a source of heat.
- ▶ When replacing battery cells, use the same type and number of cells.

Special precautions

- ▶ The UPS connection instructions contained in this manual must be followed in the indicated order.
- ▶ Check that the indications on the rating plate elles doivent correspondre à votre réseau électrique d'alimentation et à la consommation électrique réelle de l'ensemble des équipements connectés.
- ▶ If the UPS must be stored prior to installation, storage must be in a dry place.
- ▶ The admissible storage temperature range is -25°C to +45°C.
- ▶ If the UPS remains de-energised for a long period, we recommend that you energise the UPS for a period of 24 hours, at least once every month. This charges the battery, thus avoiding possible irreversible damage.
- ▶ The UPS is designed for normal climatic and environmental operating conditions concerning the altitude, ambient operating temperature, relative humidity and ambient transport and storage conditions.
- ▶ Using the UPS within the given limits guarantees its operation, but may affect the service life of certain components, particularly that of the battery and its autonomy. The maximum storage time of the UPS is limited due to the need to recharge its integrated battery.
- ▶ Unusual operating conditions may justify special design or protection measures:
 - harmful smoke, dust, abrasive dust,
 - humidity, vapour, salt air, bad weather or dripping,
 - explosive dust and gas mixture,
 - extreme temperature variations,
 - poor ventilation,
 - conductive or radiant heat from other sources,
 - cooling water containing acid or impurities which may cause scale, silt, electrolysis or corrosion of the converter parts exposed to water,
 - strong electromagnetic fields,
 - radioactive levels higher than those of the natural environment,
 - fungus, insects, vermin, etc.,
 - battery operating conditions.

- ▶ **The UPS must always be installed in compliance with:**
 - ▶ **the requirements of standard IEC 60364-4-42: protection from thermal effects.**
 - ▶ **standard IEC 60364-4-41: protection against electric shock.**
 - ▶ **standard NFC 15-100 (in France).**
 - ▶ **the requirements of standard IEC 62040-1-2.**

APC by Schneider Electric has implemented an environmental protection policy. Products are developed according to an eco-design approach.

Substances

This product does not contain CFCs, HCFCs or asbestos.

Packing

To improve waste treatment and facilitate recycling, separate the various packing components.

The cardboard we use comprises over 30% of recycled cardboard.

Sacks and bags are made of polyethylene.

Packing materials are recyclable and bear the appropriate identification symbol .

Materials	Abbreviation	Number in the symbol 
Polyethylene terephthalate	PET	01
High-density polyethylene	HDPE	02
Polyvinyl chloride	PVC	03
Low-density polyethylene	LDPE	04
Polypropylene	PP	05
Polystyrene	PS	06

Follow all local regulations for the disposal of packing materials.

End of life

APC by Schneider Electric will process products at the end of their service life in compliance with local regulations.

APC by Schneider Electric works with companies in charge of collecting and eliminating our products at the end of their service life.

Product

The product is made up of recyclable materials.

Dismantling and destruction must take place in compliance with all local regulations concerning waste.

At the end of its service life, the product must be transported to a processing centre for electrical and electronic waste.

Make the product unusable by cutting the internal supply cables.

Battery

The product contains lead-acid batteries that must be processed according to applicable local regulations concerning batteries.

The battery may be removed to comply with regulations and in view of correct disposal.

The "Material Safety Data Sheets"(MSDS) for the batteries are available on our web site*.

(*) For more information or to contact the Product Environmental manager, use the "Environmental Request" form on the site: <http://environment.apc.com>

Contents

1. Operation

1.1 Initial UPS start-up	8
Single or integrated parallel UPS alone	8
UPS set up as a frequency converter	9
Parallel UPS systems	10
integrated parallel UPS units in parallel without external bypass cabinet	10
integrated parallel UPS units in parallel with external bypass cabinet	12
UPS set up as a parallel frequency-converter system	14
Parallel UPS units with SSC (static-switch cabinet)	15
Parallel UPSs with SSC cabinet and SSC maintenance cabinet	17
1.2 Setting up the UPS or SSC	19
Human-machine interface	19
Pictograms	19
Menu structure	20
Changing the display language	21
Available languages	21
Selecting the displayed language	21
Setting the date and time	22
Setting the dry contacts	22
Accessing the parameters	22
Available commands and status conditions	23
Setting up a contact	25
Other available settings	25
1.3 Personalising the UPS	26
Accessing personalisation parameters	26
Other available personalisation commands	27

2. Maintenance

2.1 Isolating an installation	28
Single or integrated parallel UPS alone	28
Parallel UPS systems	29
integrated parallel UPS units in parallel without external bypass cabinet	29
integrated parallel UPSs in parallel with external bypass cabinet	31
UPS set up as a frequency converter	32
Parallel UPS units with SSC (static-switch cabinet)	33
Parallel UPSs with SSC cabinet and SSC maintenance cabinet	34
2.2 Transferring the UPS back to normal AC power	35
Single or integrated parallel UPS alone	35
UPS set up as a frequency converter	36
Parallel UPS systems	37
integrated parallel UPS units in parallel without external bypass cabinet	37
integrated parallel UPSs in parallel with external bypass cabinet	39
UPS set up as a frequency converter in parallel	41
Parallel UPS units with SSC (static-switch cabinet)	42
Parallel UPS units with SSC (static-switch cabinet) and SSC maintenance cabinet	44

2.3 Identifying anomalies	46
General status LEDs	46
Mimic panel	47
2.4 Life Cycle Monitoring (LCM)	48
Description	48
Alarm details	48
Disable the LCM function	48
2.5 Training centres	49
3. Appendices	
3.1 Available options	50
IP 32 option	50
Backfeed option	50
External synchronisation module option	50
Communication options	50
3.2 General characteristics of MGE™ Galaxy™ 7000 UPSs	51
3.3 Battery characteristics	52
3.4 Glossary	53

1. Operation

1.1 Initial UPS start-up

Single or integrated parallel UPS alone

 **Connection of power and control cables must be carried out and checked by qualified personnel.**
The upstream circuit breakers on the normal and bypass lines must be open.
 The UPS must be shut down; the load is not supplied.
 The doors of the cabinets must be open.

 **Before starting the sequence, the switches must be in the positions indicated below:**

UPS cabinet

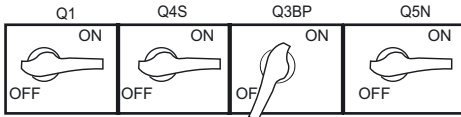

UPS cabinet

Q1	Q4S	Q3BP	Q5N
OFF	OFF	ON	OFF

Battery cabinet(s)



Battery cabinet

QF1
OFF

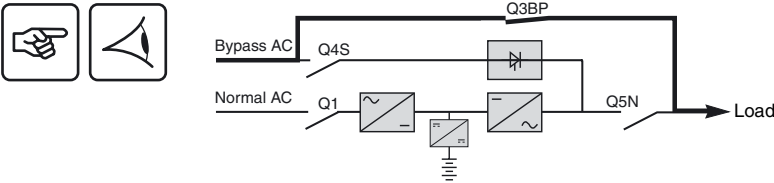

1 - Close the upstream circuit breakers on the normal and bypass lines

The load is now supplied.

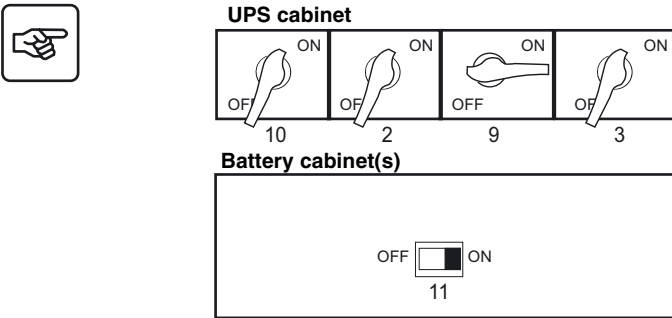

UPS cabinet

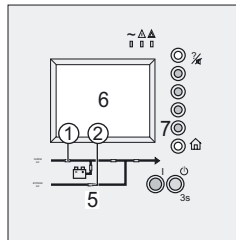

UPS cabinet:

- 2 - Flip switch Q4S to ON
- 3 - Flip switch Q5N to ON

Single UPS unit only:

- 4 - Check that the load is powered
- 5 - Check that the "Bypass" LED (2) is ON and green

integrated parallel UPS unit only:

- 6 - Check the presence of the UPS unit on the display.

- 7 - Press the Enter button
- 8 - Check that the load is powered

UPS cabinet:

- 9 - Flip switch Q3BP to OFF
- 10 - Flip switch Q1 to ON

Wait until the "PFC" LED (1) lights up green

Battery cabinet(s):

- 11 - Switch the circuit breaker(s) QF1 to ON
- 12 - Close the doors.

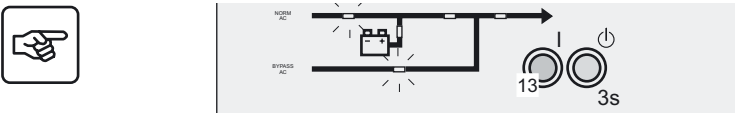

UPS cabinet:

- 13 - Press the ON button

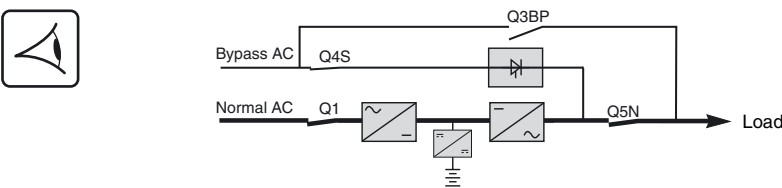

The load is now protected

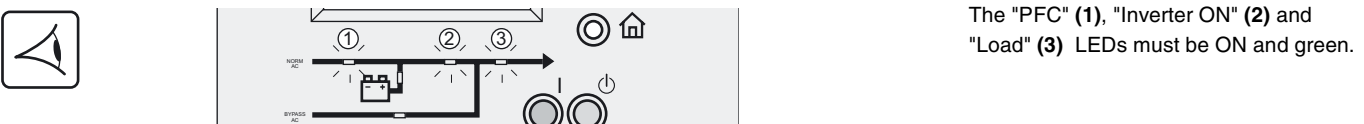

UPS set up as a frequency converter



Connection of power and control cables must be carried out and checked by qualified personnel.

The upstream circuit breaker on the normal AC line must be open.

The UPS must be shut down; the load is not supplied.

The doors of the cabinets must be open.



Before starting the sequence, the switches must be in the positions indicated below:

UPS cabinets



Battery cabinet(s)

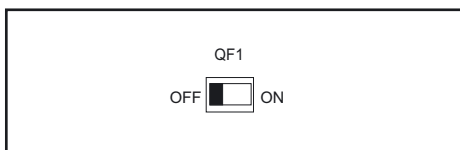

UPS cabinet

Q1			Q5N
OFF			OFF

Battery cabinet

QF1
OFF



UPS cabinets



Battery cabinet(s)

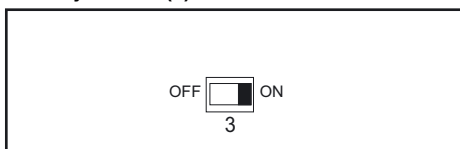

UPS cabinets

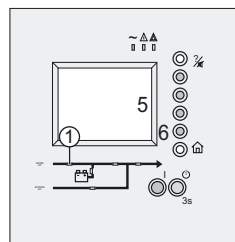

1 - Close the upstream circuit breaker on the normal AC line

UPS cabinet:

2 - Flip switch Q1 to ON

Wait until the "PFC" LED (1) lights up green

Battery cabinet(s):

3 - Switch the circuit breaker(s) QF1 to ON

UPS cabinet:

4 - Flip switch Q5N to ON

5 - Check the presence of the UPS unit on the display

6 - Press the Enter button

7 - Close the doors.

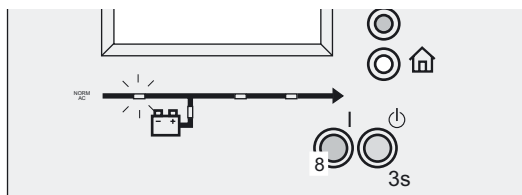

UPS cabinet:

8 - Press the ON button

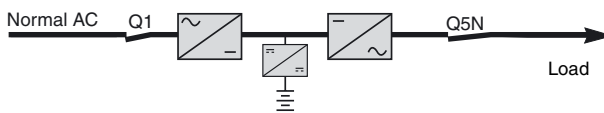

The load is now protected.

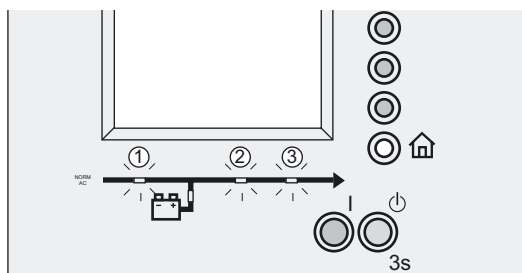

The "PFC" (1), "Inverter ON" (2) and "Load" (3) LEDs must be ON and green.

1. Operation

Initial UPS start-up >

Parallel UPS systems

integrated parallel UPS units in parallel without external bypass cabinet

 **Connection of power and control cables must be carried out and checked by qualified personnel.**
The upstream circuit breakers on the normal and bypass lines must be open.
 The UPS must be shut down; the load is not supplied.
 The doors of the cabinets must be open.

 **Before starting the sequence, the switches of all the UPS units must be in the positions indicated below:**

UPS cabinets

Q1	Q4S	Q3BP	Q5N
ON	ON	ON	ON
OFF	OFF	OFF	OFF

Battery cabinet(s)

QF1
OFF

 **1 - Close the upstream circuit breakers on the normal and bypass lines**
The load is now supplied.

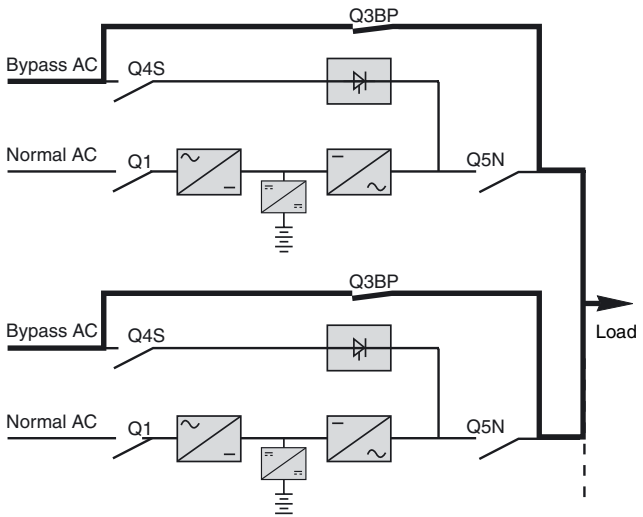

 **On each UPS cabinet:**
 2 - Flip switch Q4S to ON
 3 - Flip switch Q5N to ON

On a UPS cabinet:
 4 - Check the presence of all UPS units on the display
 5 - Press the Enter button

On each UPS cabinet:
 6 - Flip switch Q3BP to OFF
 7 - Flip switch Q1 to ON

Wait until the "PFC" LED (1) lights up green

Battery cabinet(s):
 8 - Switch the circuit breaker(s) QF1 to ON

9 - Close the doors.

UPS cabinets

7	2	6	3
ON	ON	ON	ON
OFF	OFF	OFF	OFF

Battery cabinet(s)

QF1
ON

UPS cabinets

1. Operation

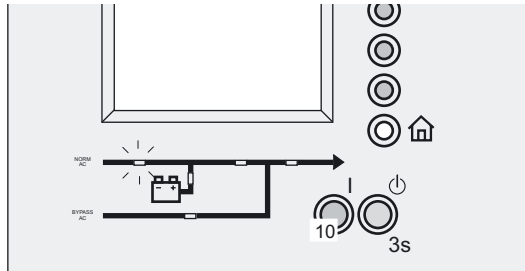

On each UPS cabinet:
10 - Press the ON button

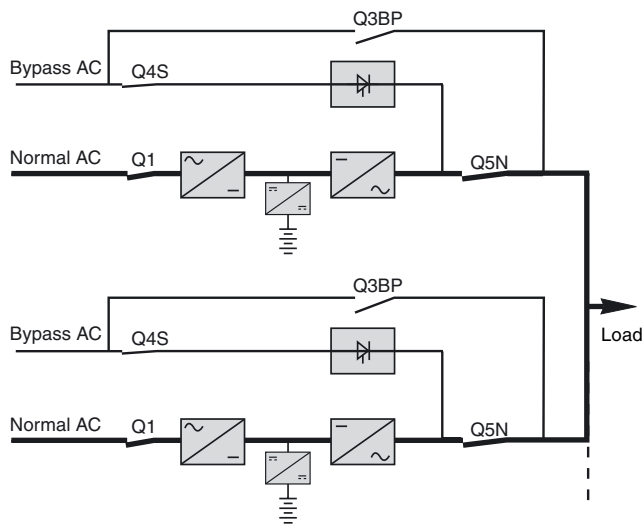

The load is supplied by the UPS system when enough units are ready.

The load is now protected.

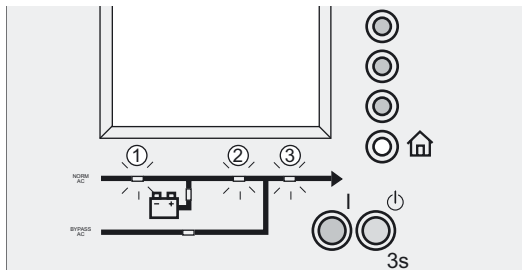

The "PFC" (1), "Inverter ON" (2) and "Load" (3) LEDs must be ON and green.

1. Operation

Initial UPS start-up > Parallel UPS systems >

integrated parallel UPS units in parallel with external bypass cabinet

Connection of power and control cables must be carried out and checked by qualified personnel.
The upstream circuit breakers on the normal and bypass lines must be open.
 The UPS must be shut down; the load is not supplied.
 Check that the handles of the Q3BP switch have been removed or locked.
 The doors of the cabinets must be open.

Before starting the sequence, the switches must be in the positions indicated below:

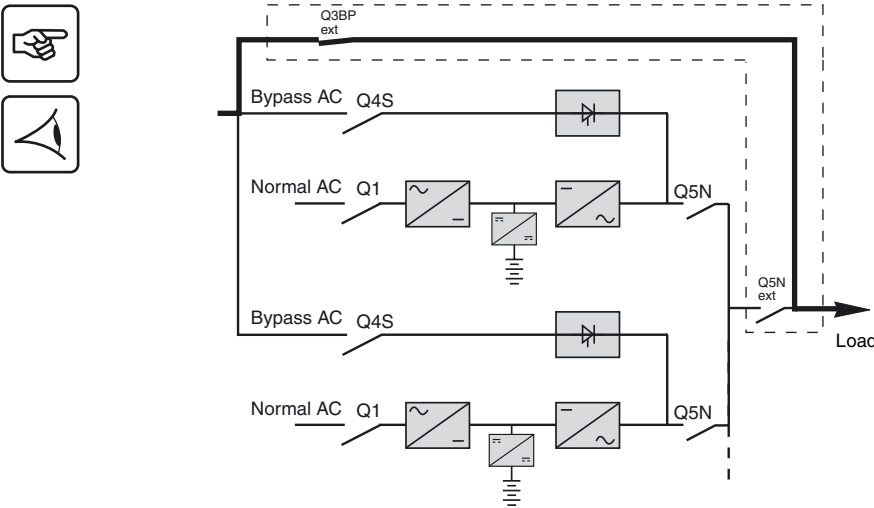
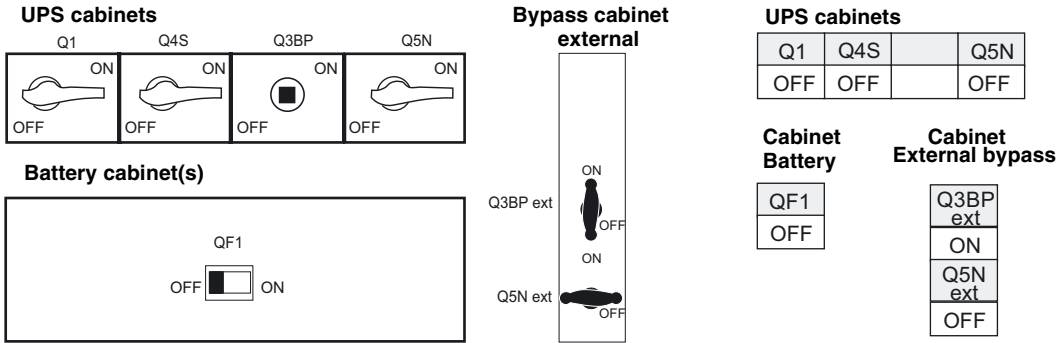

1 - Close the upstream circuit breakers on the normal and bypass lines
 The load is now supplied.

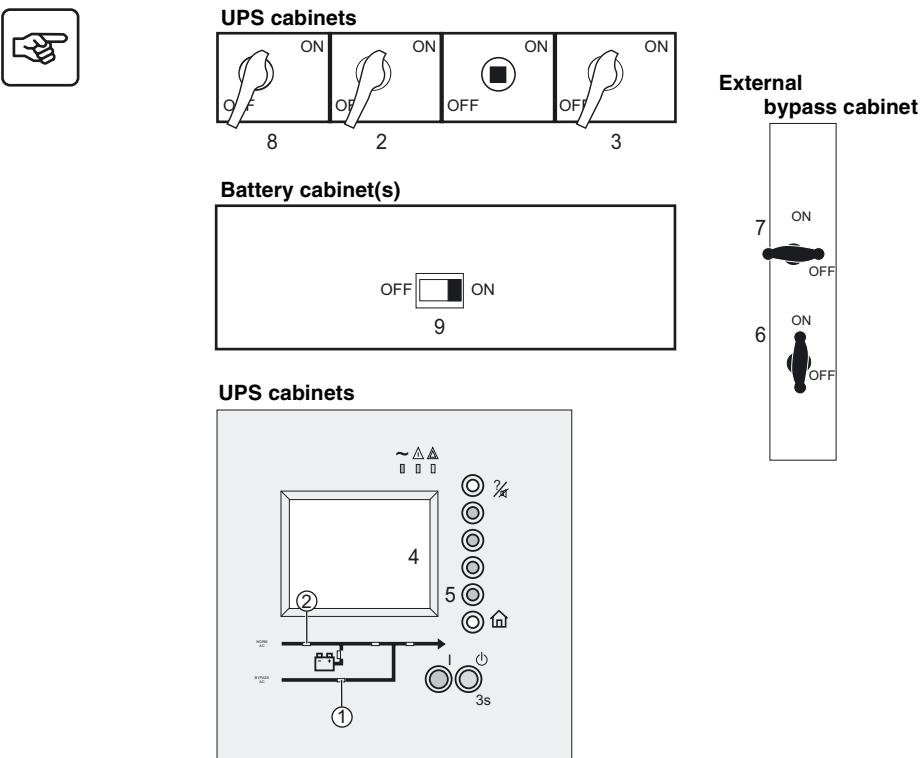

On each UPS cabinet:
 2 - Flip switch Q4S to ON
 3 - Flip switch Q5N to ON
Repeat steps 2 to 3 on all the UPS units.

On a UPS cabinet:
 4 - Check the presence of all UPS units on the display
 5 - Press the Enter button

Check that the "Automatic bypass" LED (1) lights up green

External bypass cabinet:
 6 - Flip switch Q5N ext to ON
 7 - Flip switch Q3BP ext to OFF

On each UPS cabinet:
 8 - Flip switch Q1 to ON

Wait until the "PFC" LED (2) lights up green

Battery cabinet(s):
 9 - Switch the circuit breaker(s) QF1 to ON

10 - Close the doors.

1. Operation

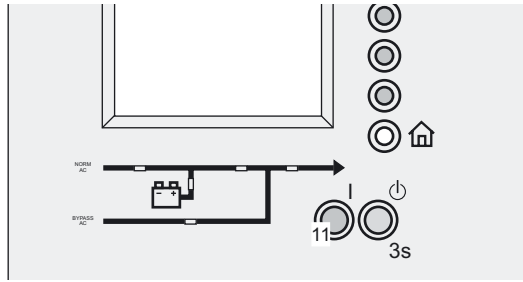

On each UPS cabinet:
11 - Press the ON button

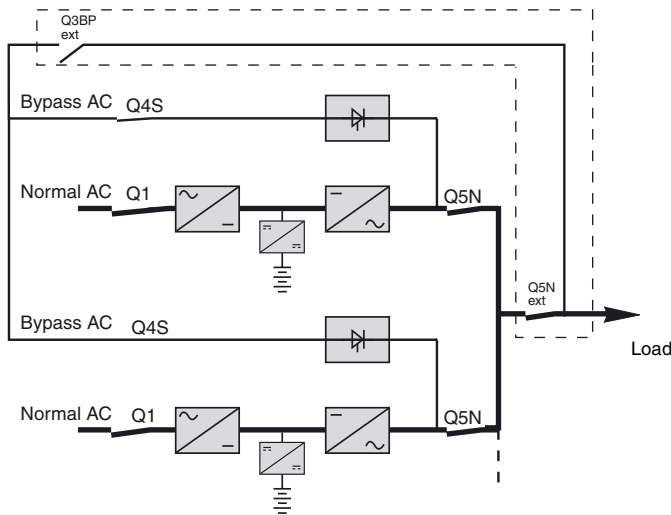

The load is supplied by the UPS system when enough units are ready.

The load is now protected.

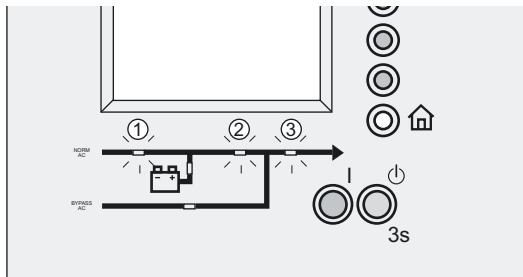



The "PFC" (1), "Inverter ON" (2) and "Load" (3) LEDs must be ON and green.

1. Operation

Initial UPS start-up > Parallel UPS systems >

UPS set up as a parallel frequency-converter system

 **Connection of power and control cables must be carried out and checked by qualified personnel.**
The circuit breakers upstream of the normal AC line must be open.
 The UPS must be shut down; the load is not supplied.
 The doors of the cabinets must be open.

 **Before starting the sequence, the switches must be in the positions indicated below:**

UPS cabinets



Battery cabinet(s)

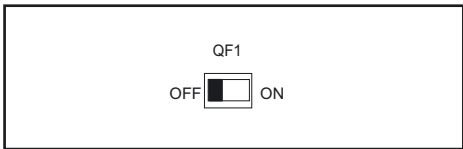



UPS cabinets

Q1			Q5N
OFF			OFF

Battery cabinet

QF1
OFF

 **UPS cabinets**



Battery cabinet(s)

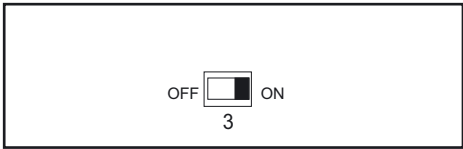

UPS cabinets

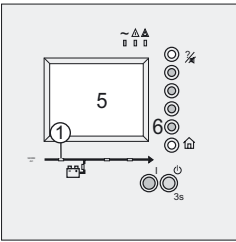

- 1 - Close the upstream circuit breaker on the normal AC lines
- On each UPS cabinet:**
 - 2 - Flip switch Q1 to ON

Check that the "PFC" LED (1) lights up green
- Battery cabinet(s):**
 - 3 - Switch the circuit breaker(s) QF1 to ON
- On each UPS cabinet:**
 - 4 - Flip switch Q5N to ON
- On a UPS cabinet:**
 - 5 - Check the presence of all UPS units on the display
 - 6 - Press the Enter button
 - 7 - Close the doors.

 **On each UPS cabinet:**

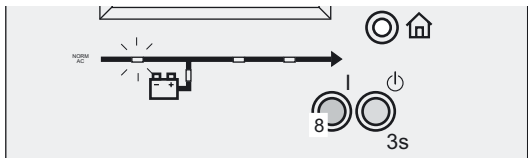

- 8 - Press the ON button

 **The load is supplied by the UPS system when enough units are ready.**
The load is now protected.

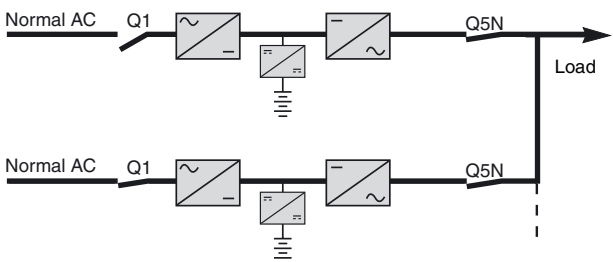

 The "PFC" (1), "Inverter ON" (2) and "Load" (3) LEDs must be ON and green.

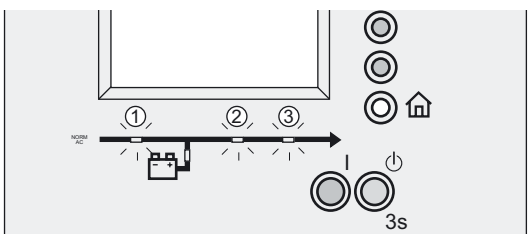

Parallel UPS units with SSC (static-switch cabinet)



Connection of power and control cables must be carried out and checked by qualified personnel.

The upstream circuit breakers on the normal and bypass lines must be open.

The UPS must be shut down; the load is not supplied.

The doors of the cabinets must be open.



Before starting the sequence, the switches must be in the following positions (see diagram opposite).

UPS cabinets



Battery cabinet(s)

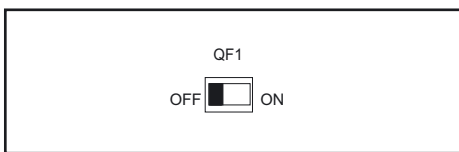

Cabinet SSC

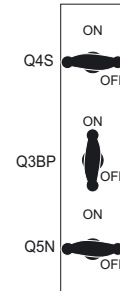

UPS cabinets

Q1			Q5N
OFF			OFF

Cabinet Battery

QF1
OFF

Cabinet SSC

Q4S
OFF
Q3BP
ON
Q5N
OFF

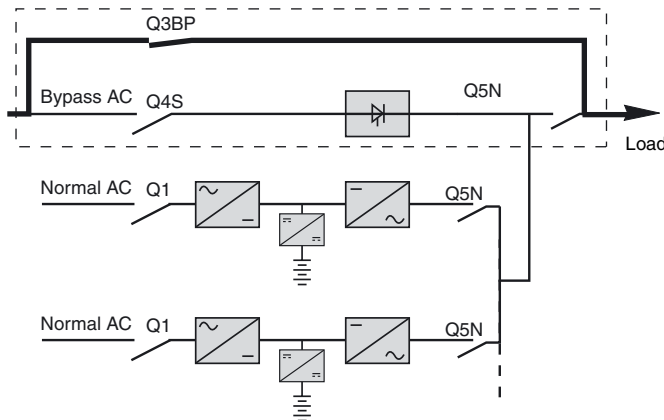

1 - Close the upstream circuit breakers on the normal and bypass lines

The load is now supplied.



SSCs

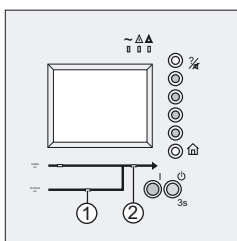

UPS cabinets



Battery cabinet(s)

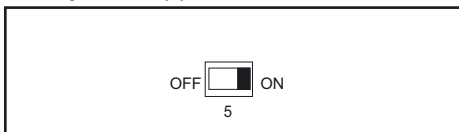

UPS cabinets

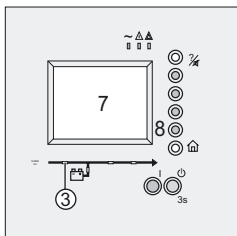

Cabinet SSC

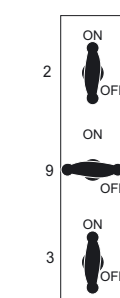

SSC cabinet:

2 - Flip switch Q4S to ON

3 - Flip switch Q5N to ON

Check that the "AC Bypass" (1) and (2) "Load" LEDs light up green

On each UPS cabinet:

4 - Flip switch Q1 to ON

Check that the "PFC" LED (3) lights up green

Battery cabinet(s):

5 - Switch the circuit breaker(s) QF1 to ON

On each UPS cabinet:

6 - Flip switch Q5N to ON

Repeat from step 4 for all the UPS units.

7 - Check the presence of all UPS units on the display of one UPS.

8 - Press the Enter button

SSC cabinet:

9 - Flip switch Q3BP to OFF

10 - Close the doors.

1. Operation

Initial UPS start-up > Parallel UPS systems > Parallel UPS units with SSC (static-switch cabinet) >

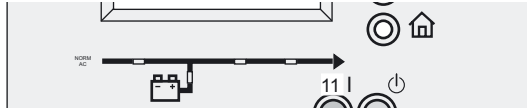

On each UPS cabinet:
11 - Press the ON button

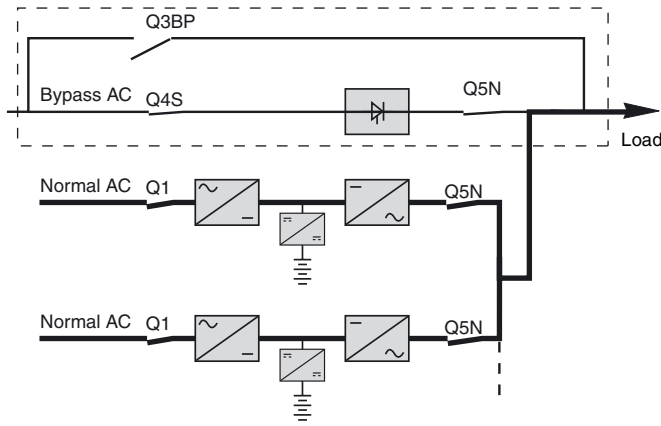

The load is supplied by the UPS system when enough units are ready.

The load is now protected.

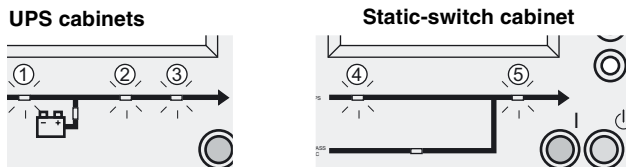

UPS cabinets:

The "PFC" (1), "Inverter ON" (2) and "Load" (3) LEDs must be ON and green.

SSC cabinet:

The "Automatic bypass"(4) and "Load" (5) LEDs must be ON and green.

Parallel UPSs with SSC cabinet and SSC maintenance cabinet



Connection of power and control cables must be carried out and checked by qualified personnel.

The upstream circuit breakers on the normal and bypass lines must be open.

The UPS must be shut down; the load is not supplied.

The doors of the cabinets must be open.



Before starting the sequence, the switches must be in the following positions (see diagram opposite).

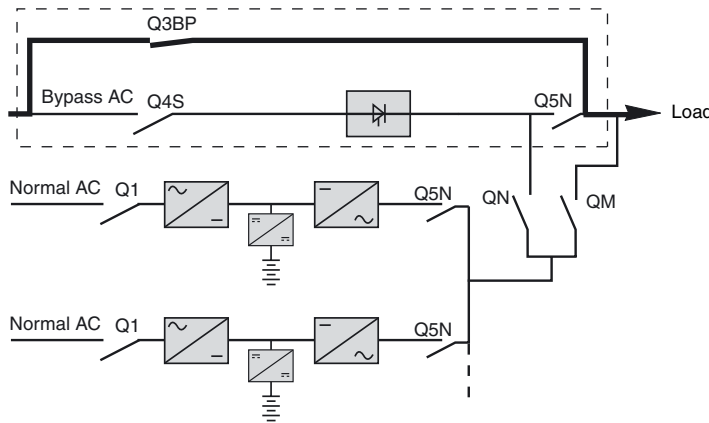
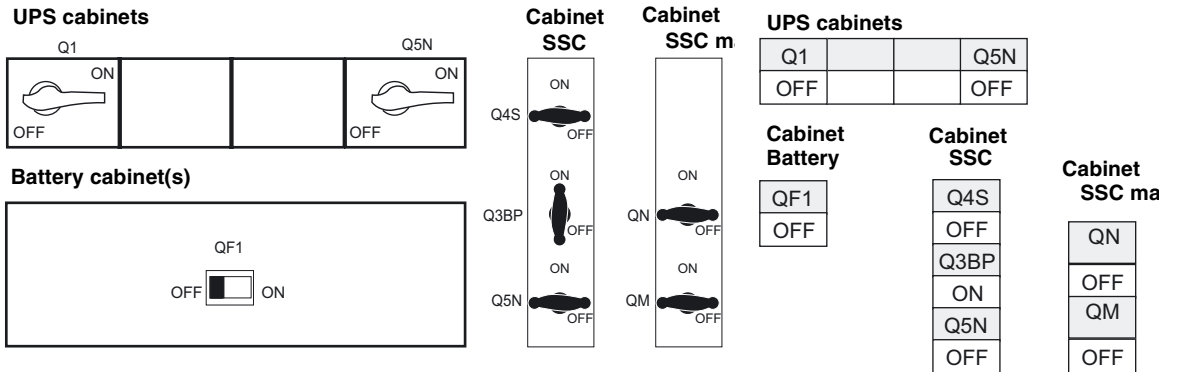

1 - Close the upstream circuit breakers on the normal and bypass lines

The load is now supplied.



Static-switch cabinet

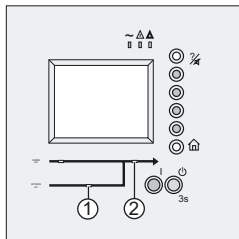

UPS cabinets



Battery cabinet(s)

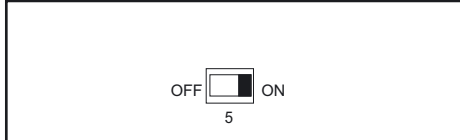

UPS cabinets

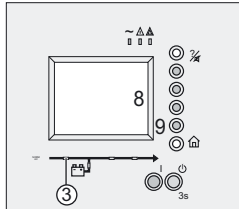

SSC cabinet:

2 - Flip switch Q4S to ON

3 - Flip switch Q5N to ON

Check that the "AC Bypass" (1) and (2) "Load" LEDs light up green

On each UPS cabinet:

4 - Flip switch Q1 to ON

Check that the "PFC" LED (3) lights up green

Battery cabinet(s):

5 - Switch the circuit breaker(s) QF1 to ON

On each UPS cabinet:

6 - Flip switch Q5N to ON

SSC maintenance cabinet:

7 - Flip switch QN to ON

Repeat from step 4 for all the UPS units.

8 - Check the presence of all UPS units on the display

9 - Press the Enter button

SSC cabinet:

10 - Flip switch Q3BP to OFF

11 - Close the doors.

1. Operation

Initial UPS start-up > Parallel UPS systems > Parallel UPSs with SSC cabinet and SSC maintenance cabinet >

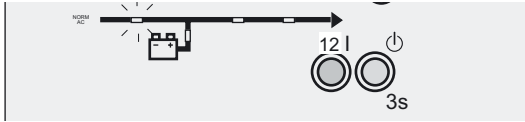

On each UPS cabinet:
12 - Press the ON button

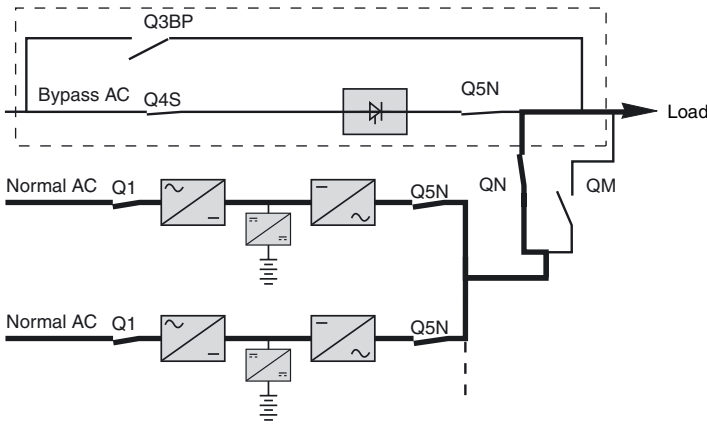

The load is supplied by the UPS system when enough units are ready.

The load is now protected.

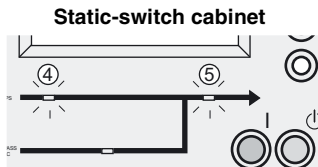
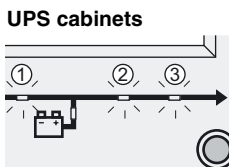

UPS cabinets:

The "PFC" (1), "Inverter ON" (2) and "Load" (3) LEDs must be ON and green.

SSC cabinet:

The "Automatic bypass"(4) and "Load" (5) LEDs must be ON and green.

1.2 Setting up the UPS or SSC

Human-machine interface

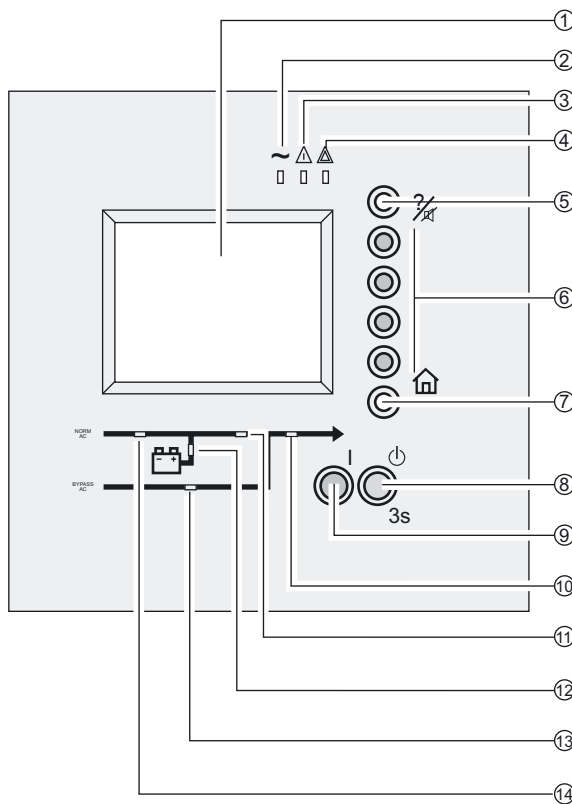

- Graphical display(1)
- Load protected LED (2)
- Minor or Environmental fault LED (3)
- Load not protected LED (4)
- Help/Buzzer off button (5)
- Function keys (6)
- Main menu button (7)
- OFF button (8)
- ON button (9)
- Load LED (10)
- Inverter LED (11)
- Battery LED (12)
- Bypass LED (13)
- PFC LED (14)

Pictograms



	Vertical selection		Delete
	Other selection		Measurements
	Enter / Confirm		Increase
	Next page		Decrease
	Previous page		Save
	Details		Alarm
	History		Details on each module
	Return to previous display		

1. Operation

Setting up the UPS or SSC >

Menu structure

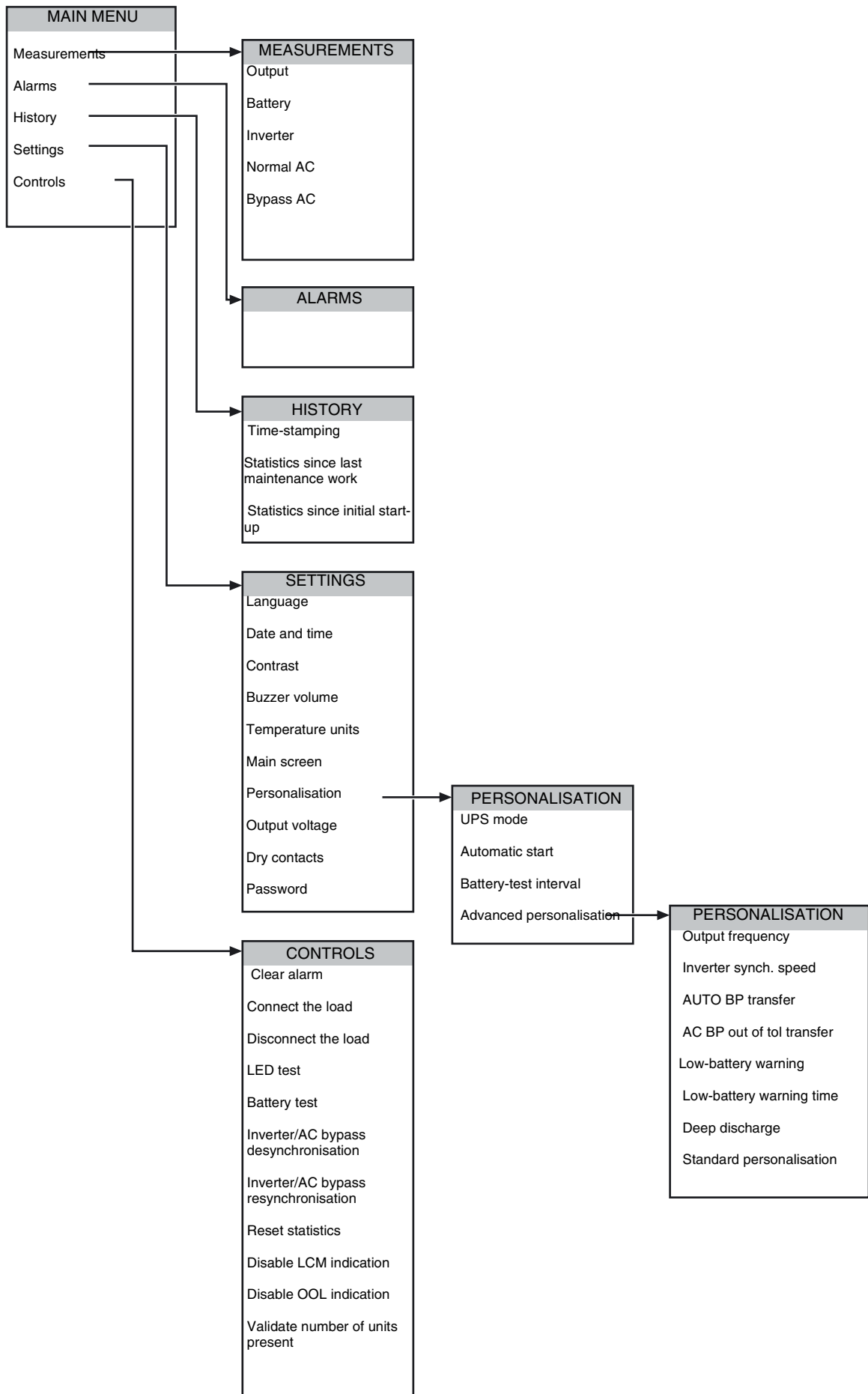

Changing the display language

Available languages

German	Italian
English	Mandarin
Korean	Norwegian
Danish	Polish
Spanish	Portuguese
Finnish	Russian
French	Swedish
Greek	Thai
Dutch	Turkish
Indonesian	

Selecting the displayed language



The UPS must be ON.

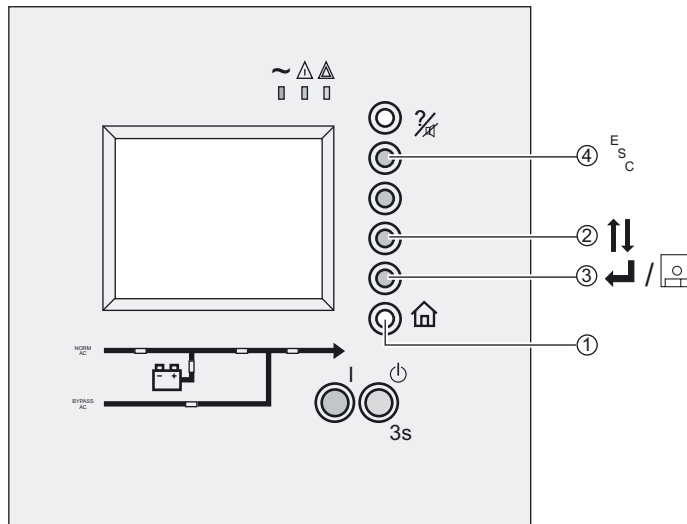

- 1 - Press the Main menu button (1)
- 2 - Press the Next button (2) until Settings is highlighted
- 3 - Press the Enter button (3)
- 4 - Press the Next button (2) until Languages is highlighted
- 5 - Press the Enter button (3)
- 6 - Press the Next button (2) until the desired language is highlighted
- 7 - Press the Save button (3)
- 8 - Press the ESC (Escape) button (4)

1. Operation

Setting up the UPS or SSC >

Setting the date and time



For event time-stamping, the correct date and time must be set.
The UPS must be ON.

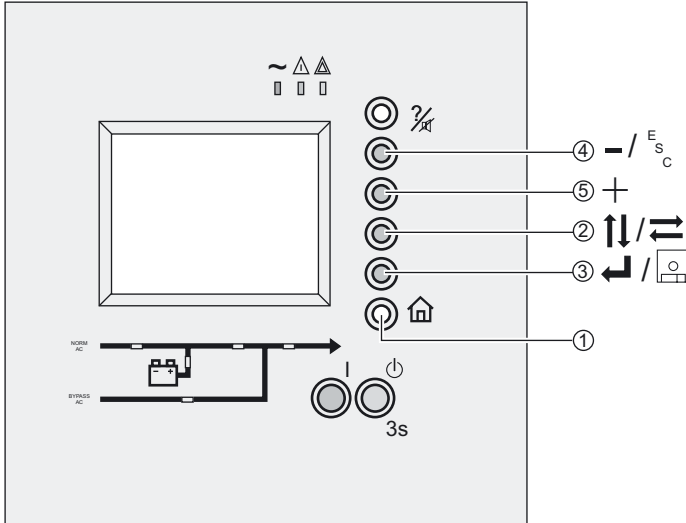

- 1 - Press the Main menu button (1)
- 2 - Press the Next button (2) until Settings is highlighted
- 3 - Press the Enter button (3)
- 4 - Press the Next button (2) until Date and time is highlighted
- 5 - Press the Enter button (3)
- 6 - Press the Decrease (4) and Increase (5) buttons until the desired date is displayed.
- 7 - Press the Next button (2)
- 8 - Repeat operations 6 and 7 to set the month, year, hour, minutes and seconds.
- 9 - Press the Save button (3)
- 10 - Press the ESC (Escape) button (4)

Setting the dry contacts

Accessing the parameters



The UPS must be ON.

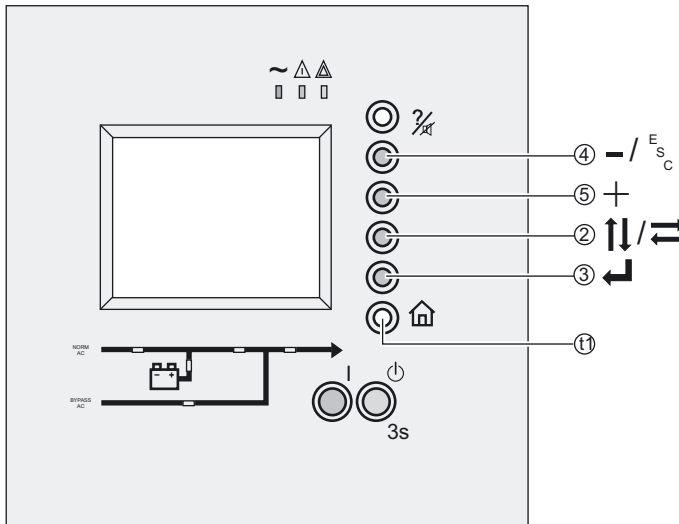

- 1 - Press the Main menu button (1)
- 2 - Press the Next button (2) until Settings is highlighted
- 3 - Press the Enter button (3)
- 4 - Press the Next button (2) until Dry contacts is highlighted
- 5 - Press the Enter button (3)
- 6 - Press the Decrease (4) and Increase (5) buttons until the first digit of the password is displayed.
- 7 - Press the Next button (2)
- 8 - Repeat operations 6 and 7 to set the second and third digits of the password.
- 9 - Press the Enter button (3)

The default password (factory set) is:



Available commands and status conditions

By default, contacts are not set up

Available status conditions (outputs: O1 to O6):

	Type of installation				
	Unitary	integrated parallel	Parallel	SSC	Frequency converter
General alarm	✓	✓	✓	✓	✓
Load on normal AC input	✓	✓	✓		✓
Load on battery power	✓ *	✓ *	✓ *		✓ *
Load on bypass AC input	✓	✓		✓	
Battery shutdown warning	✓ *	✓ *	✓ *		✓ *
Overloads	✓	✓	✓	✓ **	✓ *
Battery fault	✓ *	✓ *	✓ *		✓ *
PFC fault	✓	✓	✓		✓
Inverter fault	✓	✓	✓		✓
Charger fault	✓	✓	✓		✓
Bypass fault	✓	✓		✓	
Battery temperature fault	✓ *	✓ *	✓ *		✓ *
Ventilation fault	✓	✓	✓	✓ ***	✓
Bypass source outside tolerances	✓	✓		✓	
Fuse fault	✓	✓	✓		✓
EPO activated	✓	✓	✓	✓	✓
Battery circuit breaker(s) open	✓ *	✓ *	✓ *		✓ *
Phase rotation fault	✓	✓	✓	✓	✓
System in maintenance position	✓	✓	✓	✓	✓
Load protected	✓	✓	✓	✓	✓
Environment fault	✓	✓	✓	✓	✓
Check the UPS	✓	✓	✓	✓	✓

* States available in installations with batteries

** Overload of AC Bypass static switch

*** State available in 800 kVA SSC cabinet only

1. Operation

Setting up the UPS or SSC > Setting the dry contacts >

Available commands (inputs: I1 to I4):

	Type of installation				
	Unitary		Parallel	SSC **	Frequency converter
Batt. room vent. fault	✓ *	✓ *	✓ *		✓ *
Desynchronise AC bypass and inverter	✓	✓	✓	✓	
Limit battery charge current during operation on genset power	✓ *	✓ *	✓ *		✓ *
Limit input power during operation on genset power	✓	✓	✓		✓
Safe transfer to inverter	✓	✓	✓	✓	
Safe transfer to AC bypass	✓	✓	✓	✓	
Force transfer to AC bypass	✓	✓	✓	✓	✓
Force transfer to inverter	✓	✓	✓	✓	✓
Battery-block fault	✓ *	✓ *	✓ *		✓ *
- Customer alarm 1	✓	✓	✓	✓	✓
- Customer alarm 2	✓	✓	✓	✓	✓
- Customer alarm 3	✓	✓	✓	✓	✓
- Customer alarm 4	✓	✓	✓	✓	✓

* Commands available in installations with batteries

** SSC cabinet commands are sent simultaneously to all UPS and/or SSC cabinets in the installation

Setting up a contact

Set-up example for an output contact.

It is necessary to first access the parameters (See "Accessing the parameters", page 22.)
The procedure is identical for an input contact.

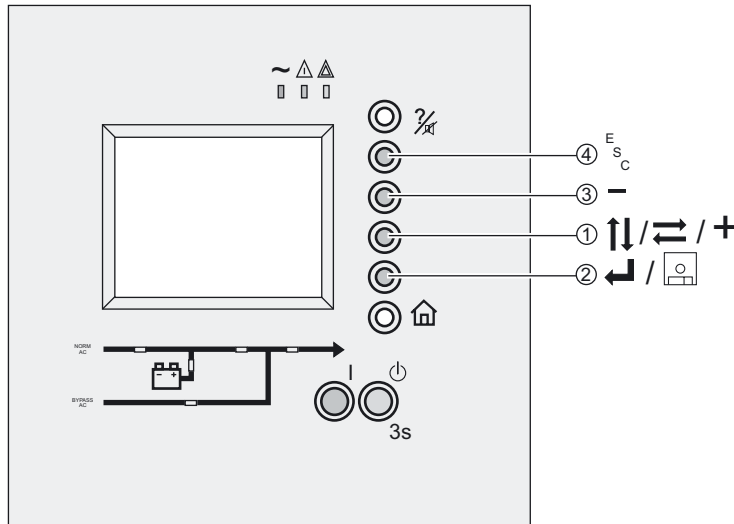

- 1 - Press the Next button (1) until Output is highlighted
- 2 - Press the Enter button (2)
- 3 - Press the Next button (3) until the contact to be set is highlighted
- 4 - Press the Enter button (2)
- 5 - Press the Next button (3) until the desired status condition is highlighted
- 6 - Press the Enter button (2)
- 7 - Press the Decrease (1) and Increase (3) buttons until the desired delay is displayed
- 8 - Press the Enter button (2)
- 9 - Press the Save button (2)
- 10 - Press the Next button (1) until Yes is highlighted
- 11 - Press the Enter button (2)
- 12 - Press the ESC (Escape) button (4)

Other available settings

Settings	Possible choices
Contrast	0 to 100% in 10% steps
Buzzer volume	0 to 100% in 10% steps
Temperature units	°C or °F
Main screen	Default main screen, Alarms, Load measurements (1) or (2), Battery measurements, Normal AC measurements, Bypass AC measurements
Output voltage	+/- 3% in 0.5 V steps
Password	New password (the default value is 000)

1. Operation

Personalising the UPS >

1.3 Personalising the UPS

Accessing personalisation parameters



The door must be open
The UPS must be ON.



Before starting, the UPS must be in maintenance mode.

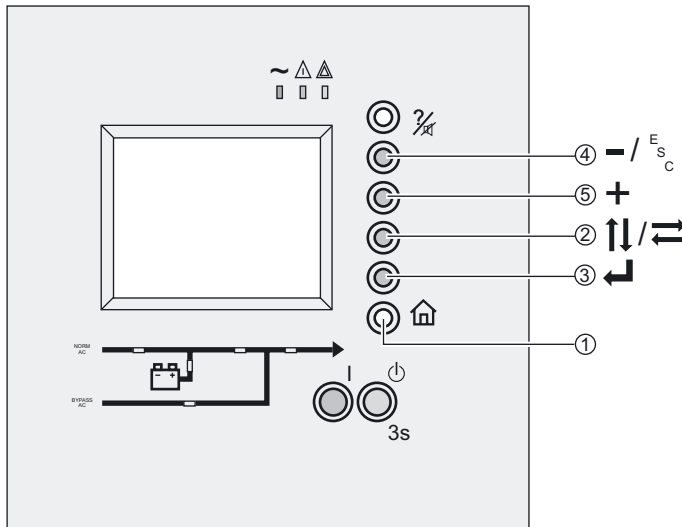

- 1 - Press the Main menu button **(1)**
- 2 - Press the Next button **(2)** until Settings is highlighted
- 3 - Press the Enter button **(3)**
- 4 - Press the Next button **(2)** until Personalisation is highlighted
- 5 - Press the Enter button **(3)**
- 6 - Press the Decrease **(4)** and Increase **(5)** buttons until the first digit of the password is displayed.
- 7 - Press the Next button **(2)**
- 8 - Repeat operations 6 and 7 to set the second and third digits of the password.
- 9 - Press the Enter button **(3)**

The default password (factory set) is:



Other available personalisation commands



Most personalisation settings lead to UPS restart.

Before starting the personalisation sequence, the UPS must be transferred to the manual bypass (load supplied via the bypass AC source).

Standard personalisation functions*	Factory set-up	Other possible choices
Automatic start	Disabled	Enabled
Battery-test interval**	1 month	never, 7 days, 1 month, 2 months, 6 months
Load level warning*	100 %	40 to 100% in 10% steps
Advanced personalisation functions*	Factory set-up	Other possible choices
Output frequency	50 Hz	60 Hz
Inverter synch. speed	2 Hz/s	1 Hz/s
Transfer to bypass AC input	Always	Never
AC BP out of tol. transfer	Enabled	Disabled
Low-battery warning voltage coeff.**	20 %	40 %, 60 %, 80 %
Low-battery warning time**	4 minutes	0 to 10 minutes in 1-minute steps
Deep discharge ***	Disabled	Enabled

* Some personalisation functions may not be available depending on your installation.

** These personalisation settings are dynamic and do not require the UPS to be transferred to manual bypass.

*** Battery discharge beyond the permitted limit leading to irreversible damage to the battery; this personalisation setting is dynamic and does not require the UPS to be transferred to manual bypass.



After the personalisation sequence, the UPS must be transferred back to normal AC power, See “Transferring the UPS back to normal AC power”, page 35.

2. Maintenance

2.1 Isolating an installation

Single or integrated parallel UPS alone



The UPS must be ON.

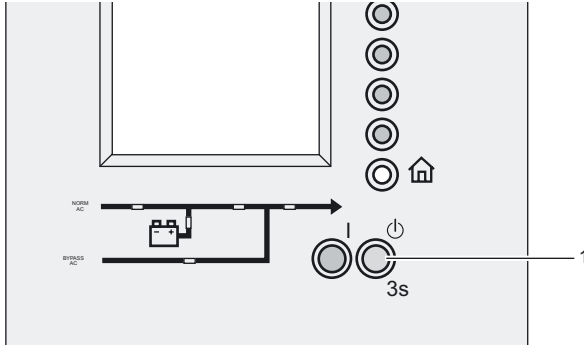

UPS cabinet

1 - Press the OFF button for 3 seconds.

The load is supplied with bypass AC power and is not protected.

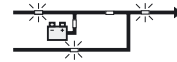

UPS cabinet

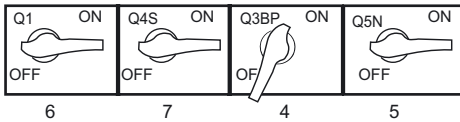

Battery cabinet(s)

2 - Flip the circuit breaker(s) QF1 to OFF

The batteries are no longer charged.

Battery cabinet(s)

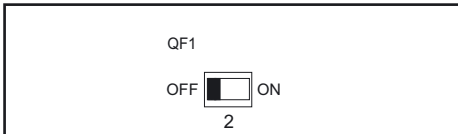

UPS cabinet

3 - Open the door.

4 - Flip switch Q3BP to ON

5 - Flip switch Q5N to OFF

6 - Flip switch Q1 to OFF

7 - Flip switch Q4S to OFF

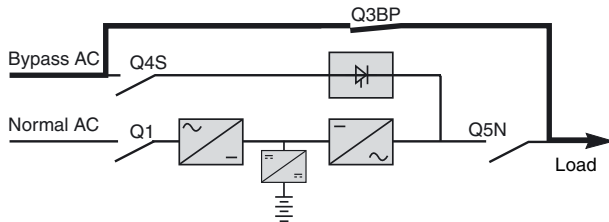

The load is now supplied with bypass AC power.

Parallel UPS systems

integrated parallel UPS units in parallel without external bypass cabinet



The UPS must be ON.

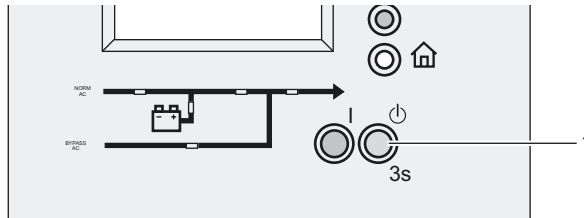

First UPS cabinet

- 1 - Press the OFF button for 3 seconds.
The load is still supplied and protected by the other UPS units.
- 2 - Open the door.



UPS cabinets

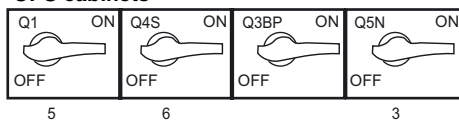

Battery cabinet(s)

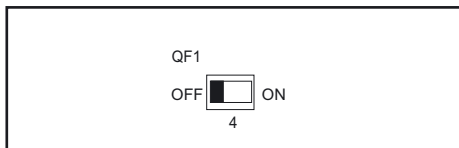

- 3 - Flip switch Q5N to OFF

Battery cabinet(s)

- 4 - Flip the circuit breaker(s) QF1 to OFF

First UPS cabinet

- 5 - Flip switch Q1 to OFF
- 6 - Flip switch Q4S to OFF

Wait until the display and LEDs go off.

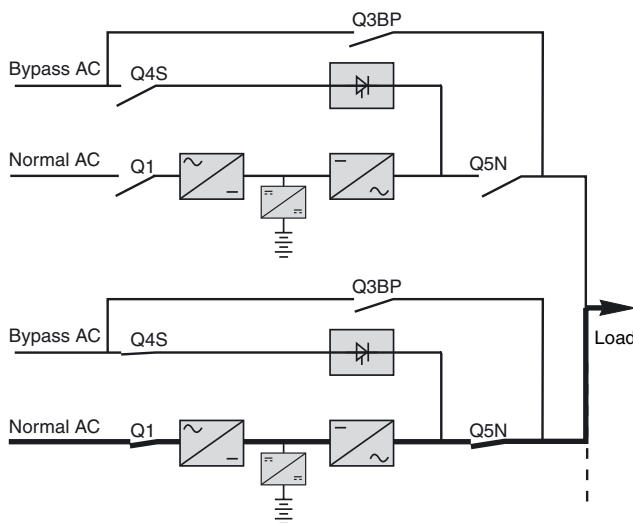

The load is still supplied and protected by the other UPS units.



UPS cabinets

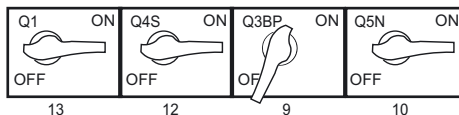

Battery cabinet(s)

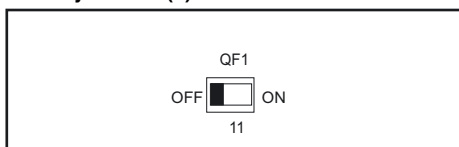

Last UPS cabinet

- 7 - Press the OFF button for 3 seconds.

The load is supplied with bypass AC power and is not protected.

- 8 - Open the door.

- 9 - Flip switch Q3BP to ON
- 10 - Flip switch Q5N to OFF

Battery cabinet(s):

- 11 - Flip the circuit breaker(s) QF1 to OFF

Last UPS cabinet

- 12 - Flip switch Q4S to OFF
- 13 - Flip switch Q1 to OFF

2. Maintenance

Isolating an installation > Parallel UPS systems > integrated parallel UPS units in parallel without external bypass cabinet >

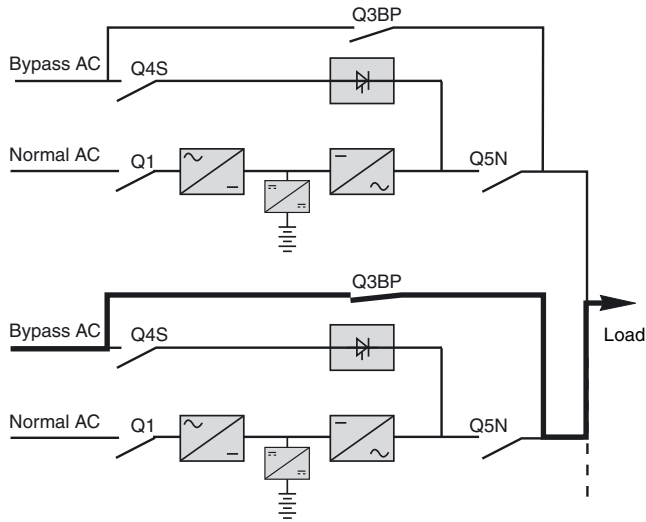

The load is supplied with bypass AC power and is not protected.

2. Maintenance

integrated parallel UPSs in parallel with external bypass cabinet



The UPS must be ON.

At the end of this procedure, the load will be supplied with bypass AC power and is not protected.

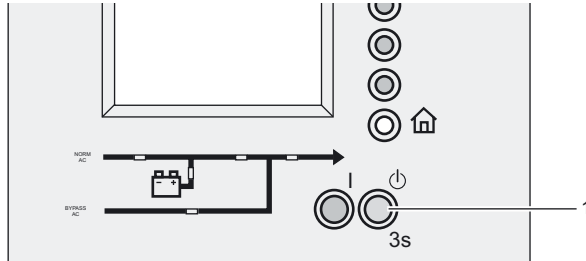

On each UPS cabinet:

1 - Press the OFF button for 3 seconds.

The load is supplied with bypass AC power and is not protected.

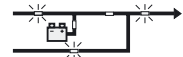

2 - Open the door.



UPS cabinets

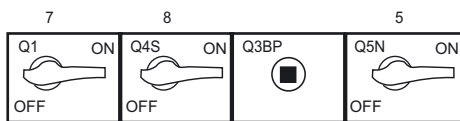

Battery cabinet(s):

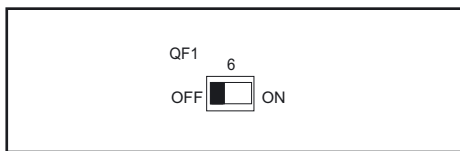

Bypass cabinet external

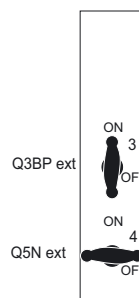

External bypass cabinet

3 - Flip switch Q3BP ext. to ON

4 - Flip switch Q5N ext to OFF

On each UPS cabinet

5 - Flip switch Q5N to OFF

Battery cabinet(s)

6 - Flip the circuit breaker(s) QF1 to OFF

On each UPS cabinet

7 - Flip switch Q1 to OFF

8 - Flip switch Q4S to OFF

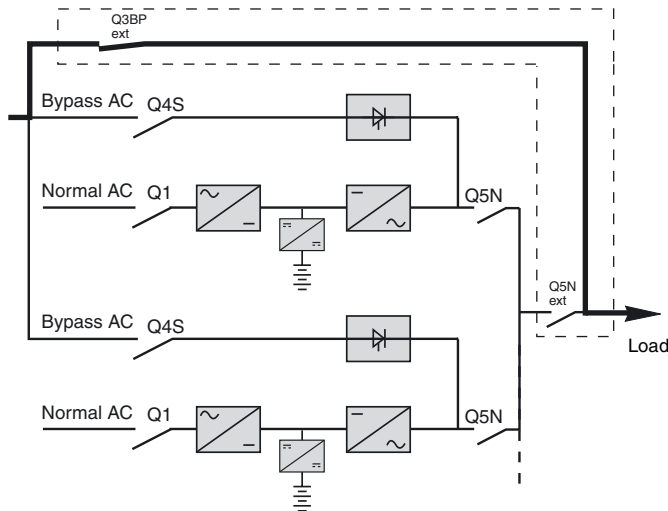

The load is now supplied via the external bypass cabinet.

2. Maintenance

Isolating an installation > Parallel UPS systems >

UPS set up as a frequency converter



The UPS must be ON.

At the end of this procedure, the load is no longer supplied with AC power.

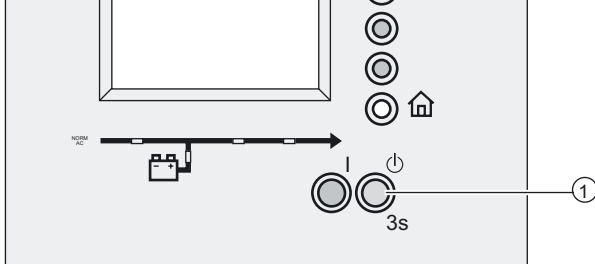

First UPS cabinet

1 - Press the OFF button (1) for 3 seconds

The load is supplied and protected by the other UPS unit.

If there is no other UPS unit, the load is no longer supplied.

2 - Open the door.



Battery cabinet(s)

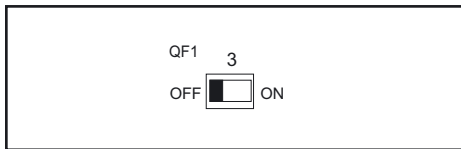

UPS cabinets



Battery cabinet(s)

3 - Flip the circuit breaker(s) QF1 to OFF

First UPS cabinet

4 - Flip switch Q5N to OFF

5 - Flip switch Q1 to OFF



Battery cabinet(s)

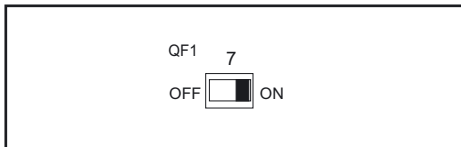

UPS cabinets



Last UPS cabinet

6 - Press the OFF button (1) for 3 seconds

The load is no longer supplied

Battery cabinet(s)

7 - Flip the circuit breaker(s) QF1 to ON

Last UPS cabinet

8 - Flip switch Q1 to OFF

9 - Flip switch Q5N to OFF

2. Maintenance

Parallel UPS units with SSC (static-switch cabinet)



The UPS must be on or have been restarted

At the end of this procedure, the load is supplied via the bypass AC input.

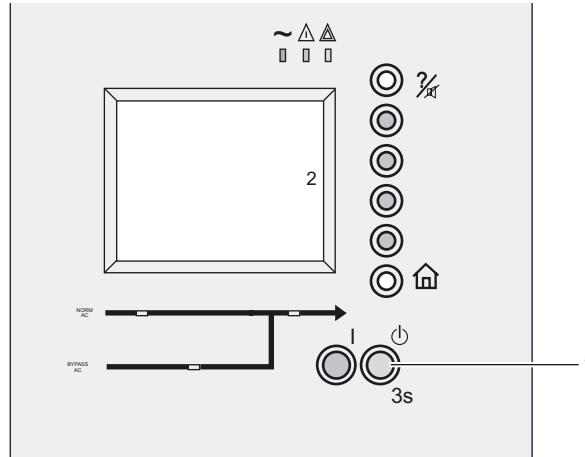

Static-switch cabinet

- 1 - Press the OFF button
- 2 - Check that all the UPS units are OFF on the display

The load is supplied with bypass AC power and is not protected.

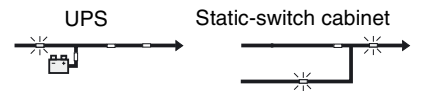

- 3 - Open the door.



UPS cabinets



Battery cabinet(s)

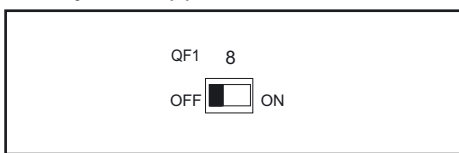

Cabinet



Static-switch cabinet

- 4 - Flip switch Q3BP to ON
- 5 - Flip switch Q5N to OFF
- 6 - Flip switch Q4S to OFF

On each UPS cabinet

- 7 - Flip switch Q5N to OFF

Battery cabinet(s)

- 8 - Flip the circuit breaker(s) QF1 to OFF

On each UPS cabinet

- 9 - Flip switch Q1 to OFF

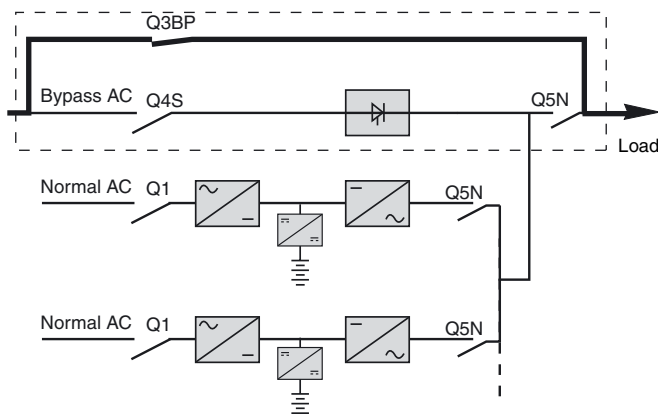

The load is supplied with bypass AC power.

2. Maintenance

Isolating an installation > Parallel UPS systems >

Parallel UPSs with SSC cabinet and SSC maintenance cabinet



The UPS must be on or have been restarted.

At the end of this procedure, the load is supplied via the bypass AC input.

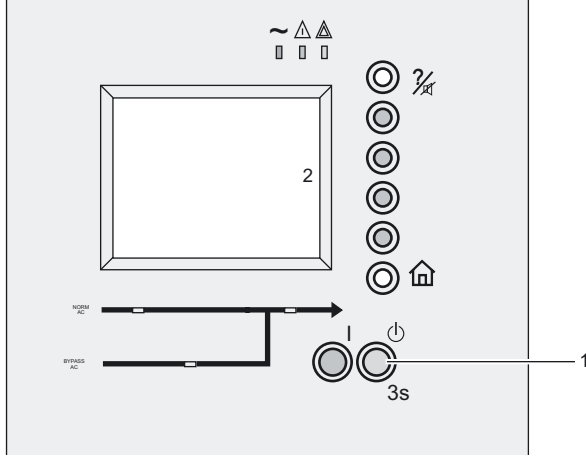

Static-switch cabinet

- 1 - Press the OFF button
- 2 - Check that all the UPS units are OFF on the display

The load is supplied with bypass AC power and is not protected.



- 3 - Open the door.



UPS cabinets



Battery cabinet(s)

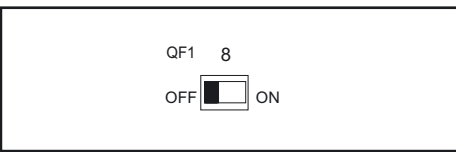

Cabinet SSC

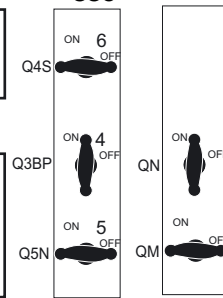

Cabinet SSC maint



Static-switch cabinet

- 4 - Flip switch Q3BP to ON
- 5 - Flip switch Q5N to OFF
- 6 - Flip switch Q4S to OFF

On each UPS cabinet

- 7 - Flip switch Q5N to OFF

Battery cabinet(s)

- 8 - Flip the circuit breaker(s) QF1 to OFF

On each UPS cabinet

- 9 - Flip switch Q1 to OFF

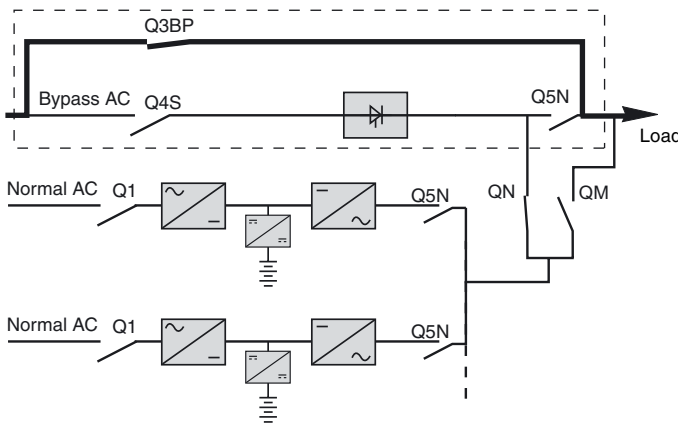

The load is supplied with bypass AC power.

2. Maintenance

Transferring the UPS back to normal AC power >

2.2 Transferring the UPS back to normal AC power

Single or integrated parallel UPS alone



The doors of the cabinets must be open.



Before starting the sequence, the switches must be in the positions indicated below:

UPS cabinet

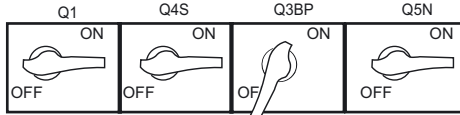

Battery cabinet(s)

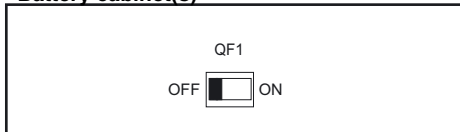

UPS cabinet

Q1	Q4S	Q3BP	Q5N
OFF	OFF	ON	OFF

Battery cabinet

QF1
OFF

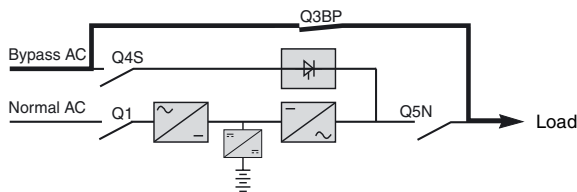

1 - Close the upstream circuit breakers on the normal and bypass lines

The load is now supplied.



UPS cabinet



Battery cabinet(s)

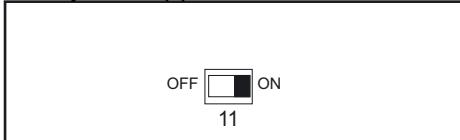

UPS cabinet

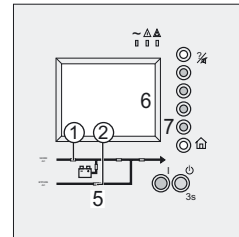

UPS cabinet:

- 2 - Flip switch Q4S to ON
- 3 - Flip switch Q5N to ON

Single UPS unit only:

- 4 - Check that the load is powered
- 5 - Check that the "Bypass" LED (2) is ON and green

integrated parallel UPS unit only:

- 6 - Check the presence of the UPS unit on the display

- 7 - Press the Enter button

- 8 - Check that the load is powered

UPS cabinet:

- 9 - Flip switch Q3BP to OFF
- 10 - Flip switch Q1 to ON

Wait until the "PFC" LED (1) lights up green

Battery cabinet(s):

- 11 - Flip the circuit breaker(s) QF1 to ON
- 12 - Close the doors.

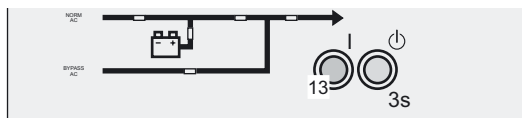

UPS cabinet:

- 13 - Press the ON button

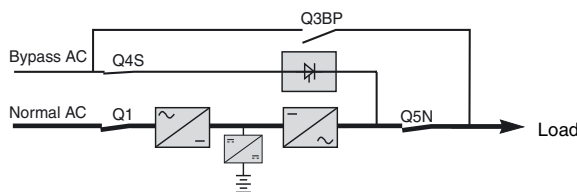

The load is now protected

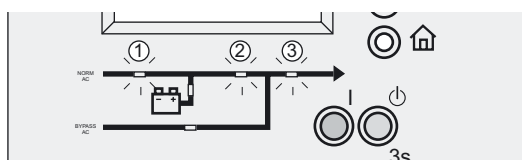

The "PFC" (1), "Inverter ON" (2) and "Load" (3) LEDs must be ON and green.

2. Maintenance

Transferring the UPS back to normal AC power > Single or integrated parallel UPS alone >

UPS set up as a frequency converter



The doors of the cabinets must be open.



Before starting the sequence, the switches must be in the positions indicated below:

UPS cabinets



Battery cabinet(s)

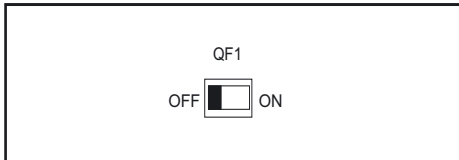

UPS cabinet

Q1			Q5N
OFF			OFF

Battery cabinet

QF1
OFF



UPS cabinets



Battery cabinet(s)

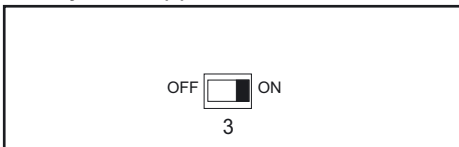

UPS cabinets

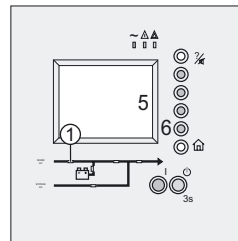

1 - Close the upstream circuit breaker on the normal AC line

UPS cabinet:

2 - Flip switch Q1 to ON

Wait until the "PFC" LED (1) lights up green

Battery cabinet(s):

3 - Flip the circuit breaker(s) QF1 to ON

UPS cabinet:

4 - Flip switch Q5N to ON

5 - Check the presence of the UPS unit on the display

6 - Press the Enter button

7 - Close the doors.

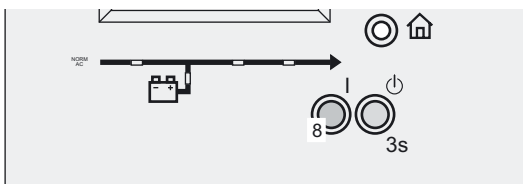

UPS cabinet:

8 - Press the ON button

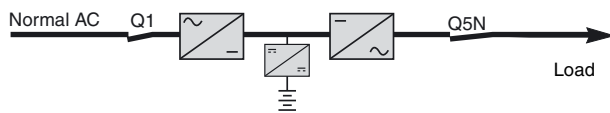

The load is now protected.

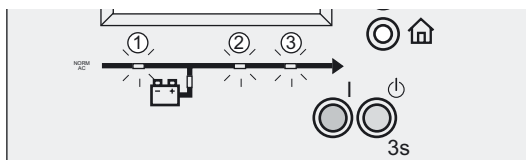

The "PFC" (1), "Inverter ON" (2) and "Load" (3) LEDs must be ON and green.

2. Maintenance

Transferring the UPS back to normal AC power >

Parallel UPS systems

integrated parallel UPS units in parallel without external bypass cabinet



The doors of the cabinets must be open.



Before starting the sequence, the switches of all the UPS units must be in the positions indicated below:

UPS cabinets

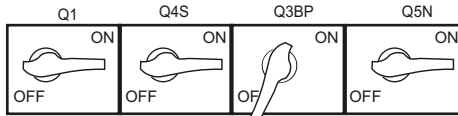

Battery cabinet(s)

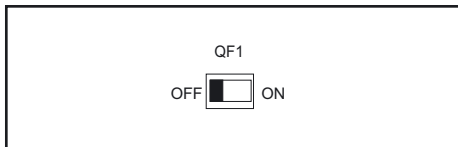

UPS cabinets

Q1	Q4S	Q3BP	Q5N
OFF	OFF	ON	OFF

Battery cabinet

QF1
OFF

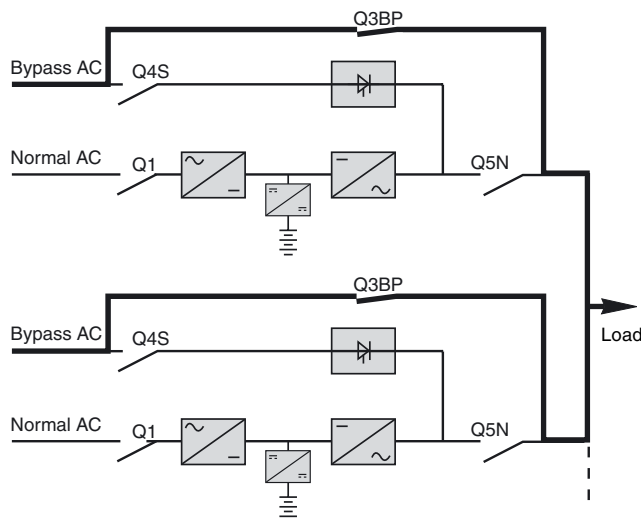

1 - Close the upstream circuit breakers on the normal and bypass lines

The load is now supplied.



UPS cabinets

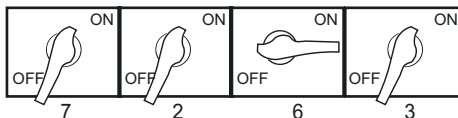

Battery cabinet(s)

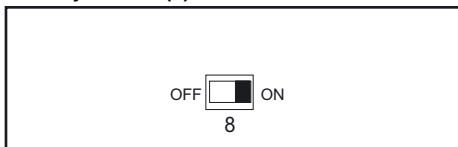

UPS cabinets

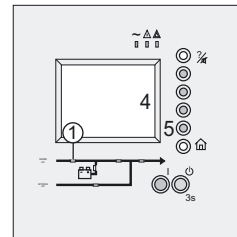

On each UPS cabinet:

- 2 - Flip switch Q4S to ON
- 3 - Flip switch Q5N to ON

On a UPS cabinet:

- 4 - Check the presence of all UPS units on the display
- 5 - Press the Enter button

On each UPS cabinet:

- 6 - Flip switch Q3BP to OFF
- 7 - Flip switch Q1 to ON

Wait until the "PFC" LED (1) lights up green

Battery cabinet(s):

- 8 - Flip the circuit breaker(s) QF1 to ON

- 9 - Close the doors.

2. Maintenance

Transferring the UPS back to normal AC power > Parallel UPS systems > integrated parallel UPS units in parallel without external bypass cabinet >

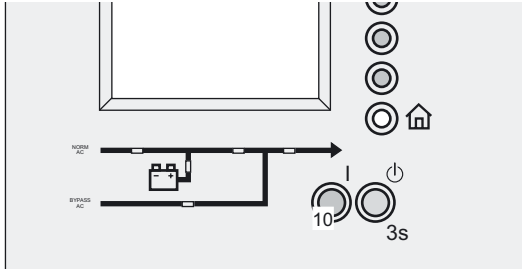

On each UPS cabinet:
10 - Press the ON button

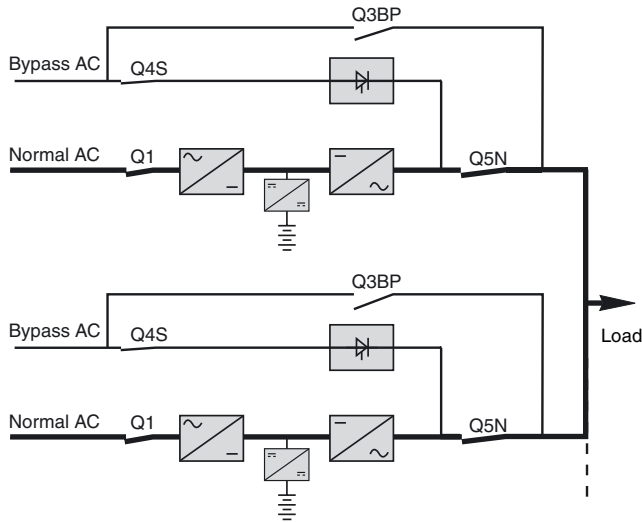

The load is supplied by the UPS system when enough units are ready.

The load is now protected.

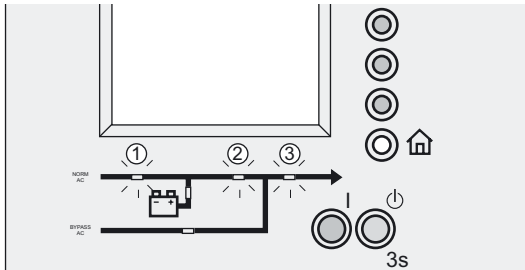

The "PFC" (1), "Inverter ON" (2) and "Load" (3) LEDs must be ON and green.

2. Maintenance

Transferring the UPS back to normal AC power > Parallel UPS systems >

integrated parallel UPSs in parallel with external bypass cabinet



Check that the handles of the Q3BP switch have been removed or locked.
The doors of the cabinets must be open.



Before starting the sequence, the switches must be in the positions indicated below:

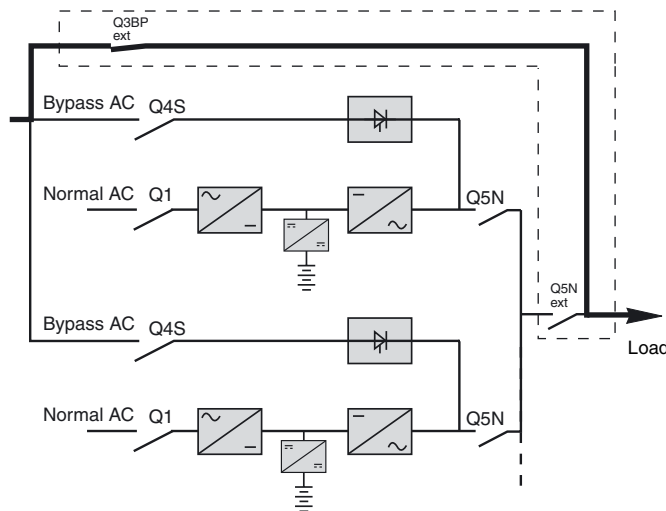
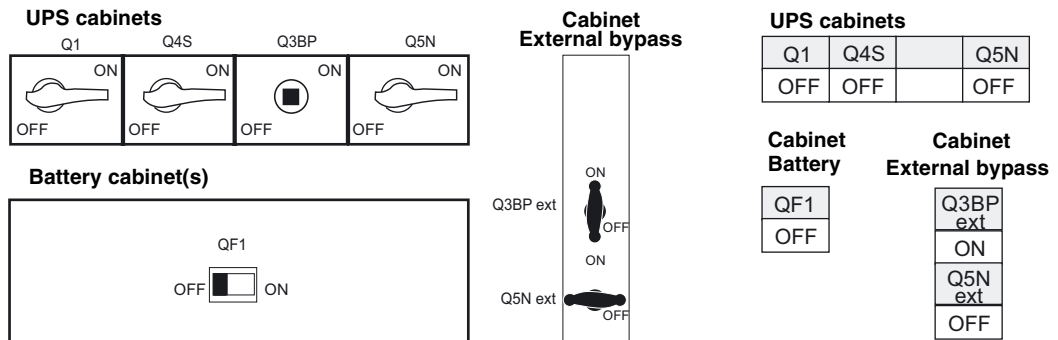

1 - Close the upstream circuit breakers on the normal and bypass lines

The load is now supplied.

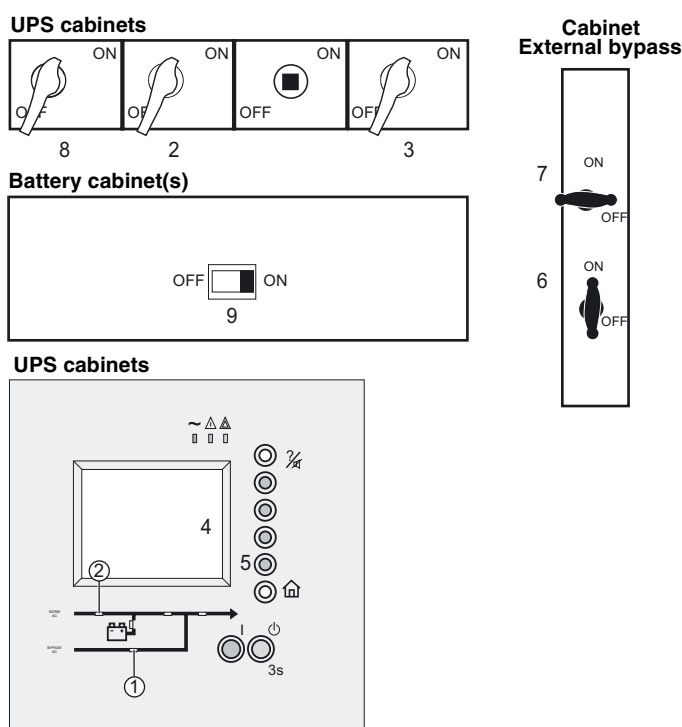

On each UPS cabinet:

2 - Flip switch Q4S to ON

3 - Flip switch Q5N to ON

Repeat steps 2 to 3 on all the UPS units.

On a UPS cabinet:

4 - Check the presence of all UPS units on the display

5 - Press the Enter button

Check that the "Automatic bypass" LED (1) lights up green

External bypass cabinet:

6 - Flip switch Q5N ext to ON

7 - Flip switch Q3BP ext to OFF

On each UPS cabinet:

8 - Flip switch Q1 to ON

Wait until the "PFC" LED (2) lights up green

Battery cabinet(s):

9 - Flip the circuit breaker(s) QF1 to ON

10 - Close the doors.

2. Maintenance

Transferring the UPS back to normal AC power > Parallel UPS systems > integrated parallel UPSs in parallel with external bypass cabinet >

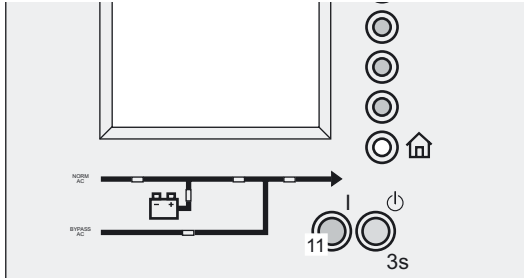

On each UPS cabinet:
11 - Press the ON button

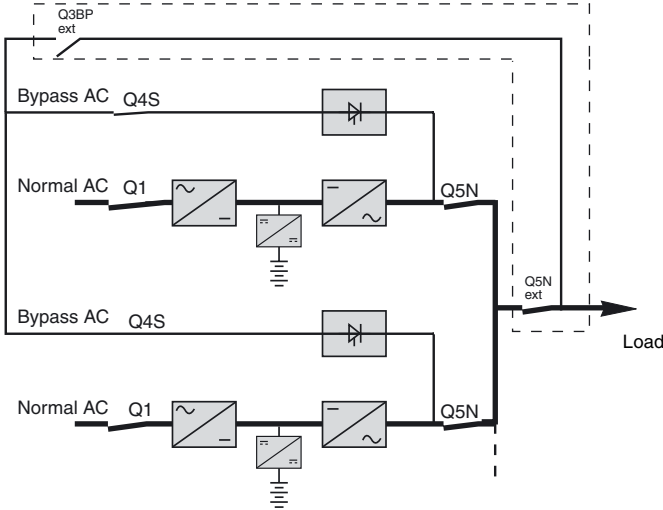

The load is supplied by the UPS system when enough units are ready.

The load is now protected.

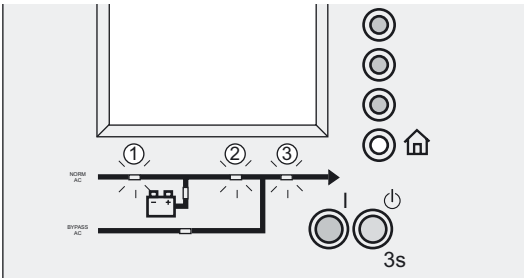

The "PFC" (1), "Inverter ON" (2) and "Load" (3) LEDs must be ON and green.

2. Maintenance

Transferring the UPS back to normal AC power > Parallel UPS systems >

UPS set up as a frequency converter in parallel



The doors of the cabinets must be open.



Before starting the sequence, the switches must be in the positions indicated below:

UPS cabinets



Battery cabinet(s)

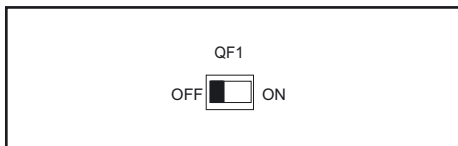

UPS cabinets

Q1			Q5N
OFF			OFF

Battery cabinet

QF1
OFF



UPS cabinets



Battery cabinet(s)

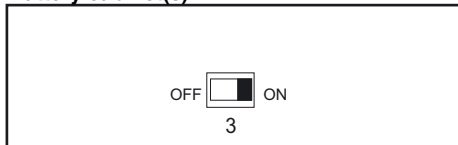

UPS cabinets

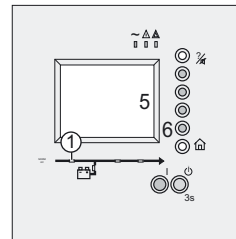

1 - Close the upstream circuit breaker on the normal AC lines

On each UPS cabinet:

2 - Flip switch Q1 to ON

Check that the "PFC" LED (1) lights up green

Battery cabinet(s):

3 - Flip the circuit breaker(s) QF1 to ON

On each UPS cabinet:

4 - Flip switch Q5N to ON

On a UPS cabinet:

5 - Check the presence of all UPS units on the display

6 - Press the Enter button

7 - Close the doors.

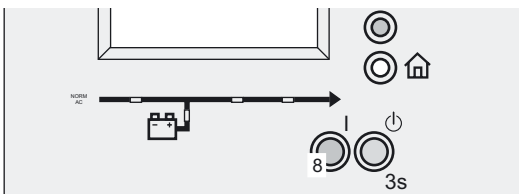

On each UPS cabinet:

8 - Press the ON button

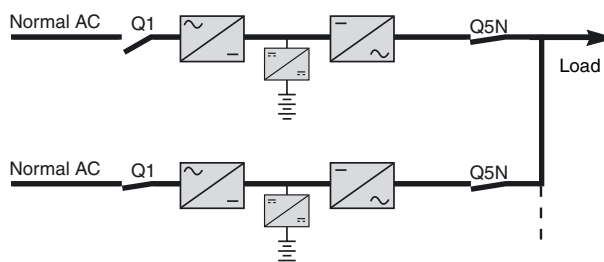

The load is supplied by the UPS system when enough units are ready.

The load is now protected.

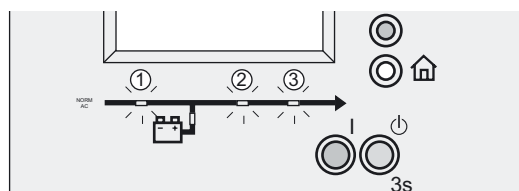

The "PFC" (1), "Inverter ON" (2) and "Load" (3) LEDs must be ON and green.

2. Maintenance

Transferring the UPS back to normal AC power > Parallel UPS systems >

Parallel UPS units with SSC (static-switch cabinet)



The doors of the cabinets must be open.



Before starting the sequence, the switches must be in the following positions (see diagram opposite).

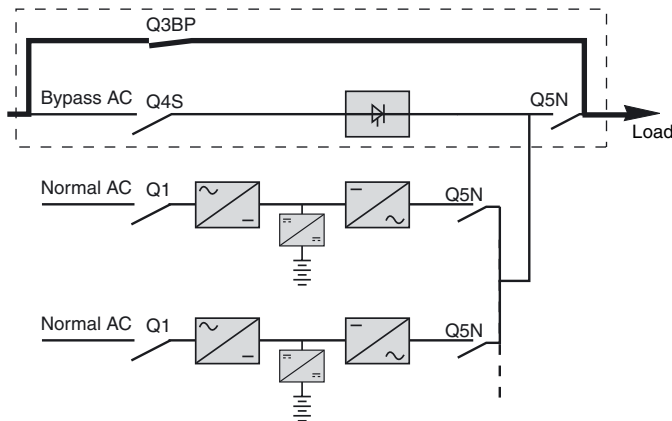
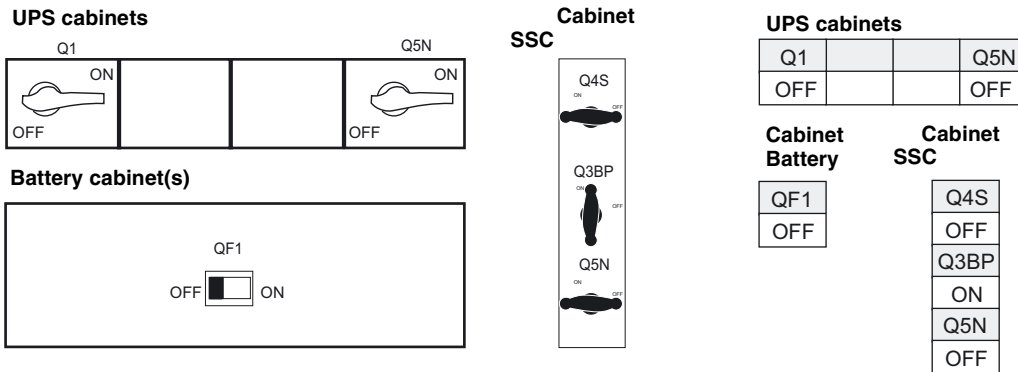

1 - Close the upstream circuit breakers on the normal and bypass lines

The load is now supplied.



Static-switch cabinet

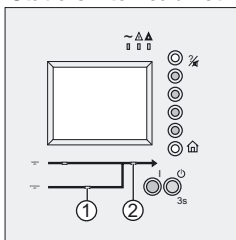

UPS cabinets

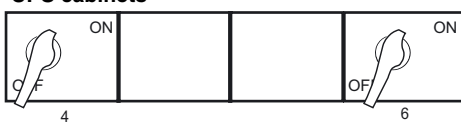

Battery cabinet(s)

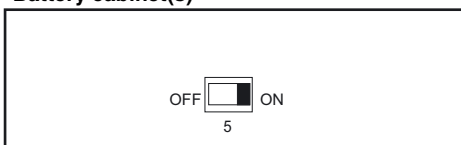

UPS cabinets

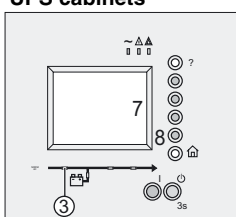

SSC cabinet:

2 - Flip switch Q4S to ON

3 - Flip switch Q5N to ON

Check that the "AC Bypass" (1) and (2) "Load" LEDs light up green

On each UPS cabinet:

4 - Flip switch Q1 to ON

Check that the "PFC" LED (3) lights up green

Battery cabinet(s):

5 - Flip the circuit breaker(s) QF1 to ON

On each UPS cabinet:

6 - Flip switch Q5N to ON

Repeat operations 4 to 6 for all the UPSs

7 - Check the presence of all UPS units and the SSC cabinet on the display of one UPS
8 - Press the Enter button

SSC cabinet:

9 - Flip switch Q3BP to OFF

10 - Close the doors.

Cabinet SSC

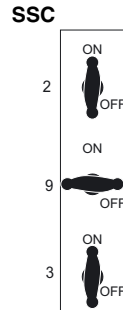

2. Maintenance

Transferring the UPS back to normal AC power > Parallel UPS systems > Parallel UPS units with SSC (static-switch cabinet) >

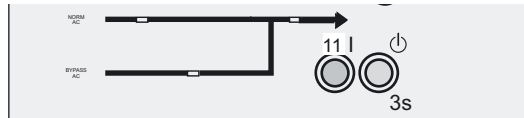

Static-switch cabinet
11 - Press the ON button

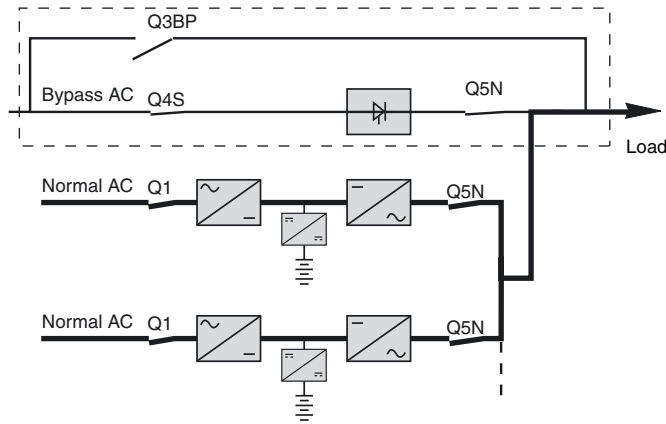

The load is supplied by the UPS system when enough units are ready.

The load is now protected.



UPS cabinets

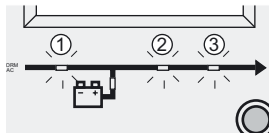

Static-switch cabinet

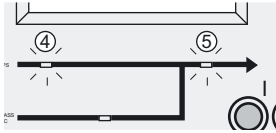

The "PFC" (1), "Inverter ON" (2) and "Load" (3) LEDs must be ON and green.

LEDs (4) and (5) must be ON and green.

2. Maintenance

Transferring the UPS back to normal AC power > Parallel UPS systems >

Parallel UPS units with SSC (static-switch cabinet) and SSC maintenance cabinet



The doors of the cabinets must be open.



Before starting the sequence, the switches must be in the following positions (see diagram opposite).

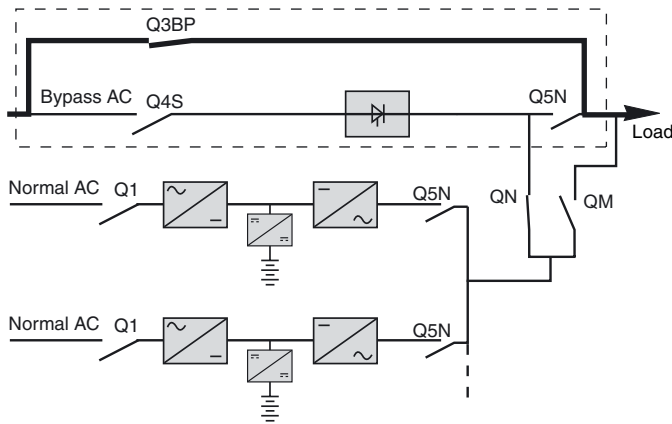
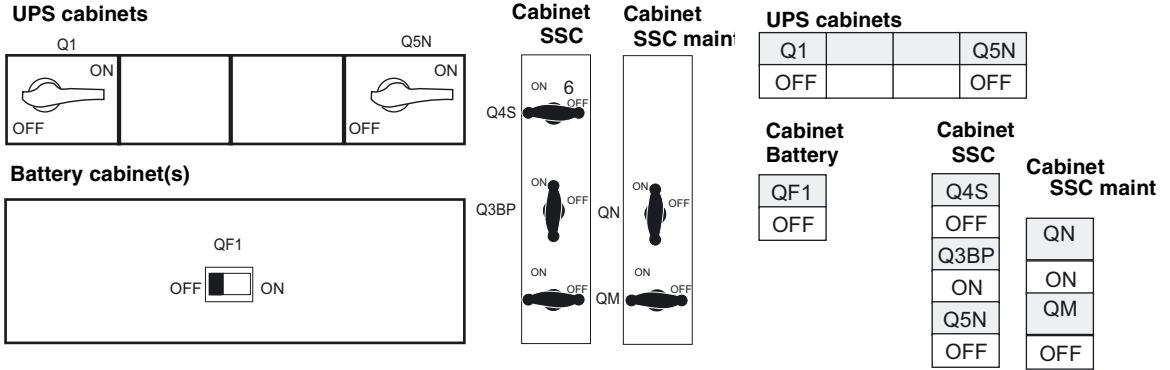

1 - Close the upstream circuit breakers on the normal and bypass lines

The load is now supplied.



SSC cabinets

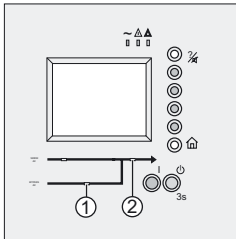

UPS cabinets



Battery cabinet(s)

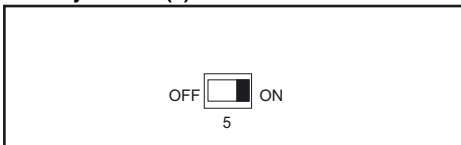

UPS cabinets

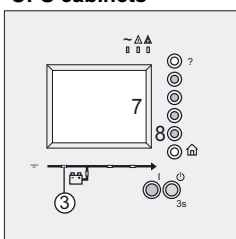

Cabinet SSC

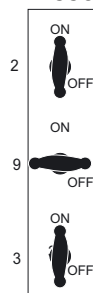

Cabinet SSC mai



SSC cabinet:

2 - Flip switch Q4S to ON

3 - Flip switch Q5N to ON

Check that the "AC Bypass" (1) and (2) "Load" LEDs light up green

On each UPS cabinet:

4 - Flip switch Q1 to ON

Check that the "PFC" LED (3) lights up green

Battery cabinet(s):

5 - Flip the circuit breaker(s) QF1 to ON

On each UPS cabinet:

6 - Flip switch Q5N to ON

Repeat operations 4 to 6 for all the UPSs

7 - Check the presence of all UPS units on the display

8 - Press the Enter button

SSC cabinet:

9 - Flip switch Q3BP to OFF

10 - Close the doors.

2. Maintenance

Transferring the UPS back to normal AC power > Parallel UPS systems > Parallel UPS units with SSC (static-switch cabinet) and SSC maintenance cabinet >

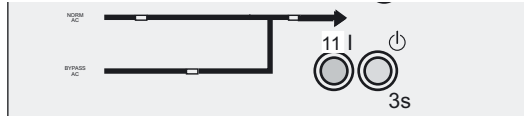

Static-switch cabinet
11 - Press the ON button

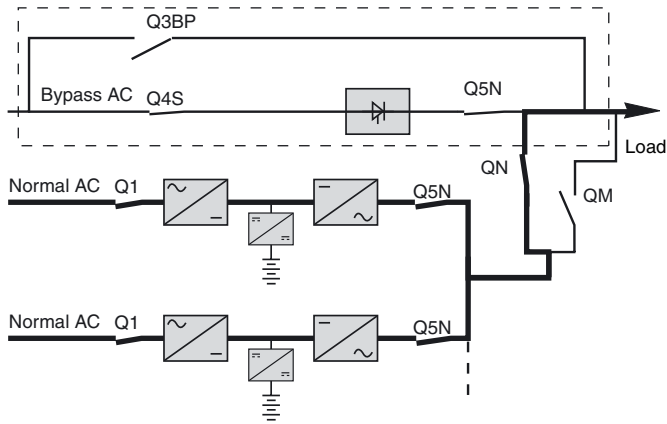

The load is supplied by the UPS system when enough units are ready.

The load is now protected.



UPS cabinets

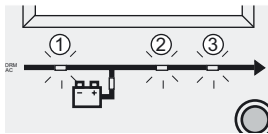

Static-switch cabinet

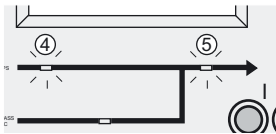

The "PFC" (1), "Inverter ON" (2) and "Load" (3) LEDs must be ON and green.

LEDs (4) and (5) must be ON and green.

2. Maintenance

Identifying anomalies >

2.3 Identifying anomalies



An anomaly has occurred when:

- at least one LED is red
- at least one LED is orange
- the buzzer beeps

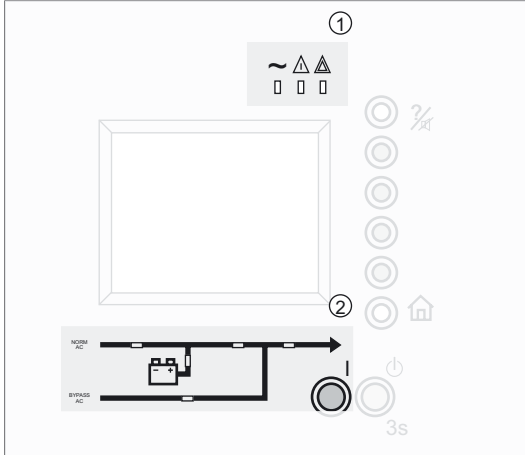

General status LEDs (1)
Mimic panel (2)

If an anomaly occurs, the display instructs the operator on the required action.

General status LEDs

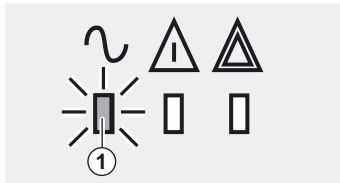

The Load protected LED (1) is ON and green:

The load is protected

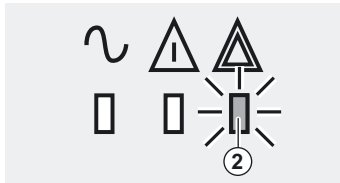

The Load not protected LED (2) goes ON red:

The load is not protected.
Follow the displayed instructions.

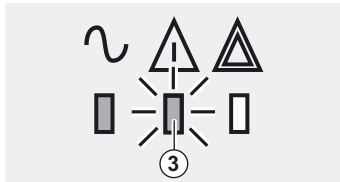

The Environment fault LED (3) is ON and orange:

Minor or environment fault.
The load is still protected.
Follow the displayed instructions.

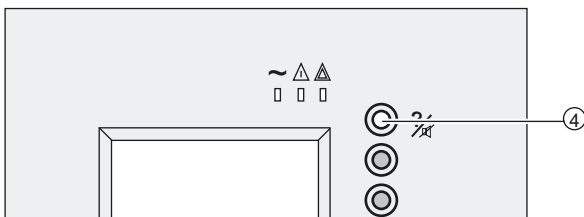

Stop the buzzer by pressing the Stop buzzer button (4)

Mimic panel

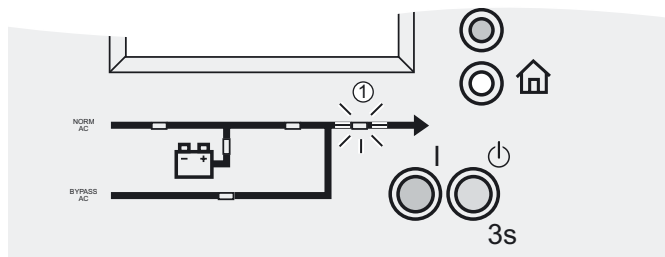

The Load LED (1) goes ON red.

The load is not supplied.

Follow the displayed instructions.

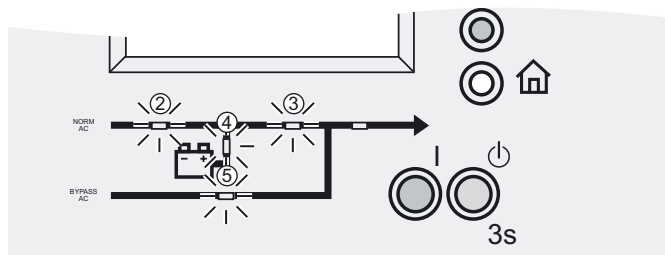

One of the following LEDs goes ON red:

PFC LED (2)

Inverter LED (3)

Battery LED (4)

Bypass LED (5)

One of the main UPS functions has faulted.

Follow the displayed instructions.

2. Maintenance

Life Cycle Monitoring (LCM) >

2.4 Life Cycle Monitoring (LCM)

Description

The Life Cycle Monitoring function provides UPS maintenance advice to guarantee installation availability for the user.

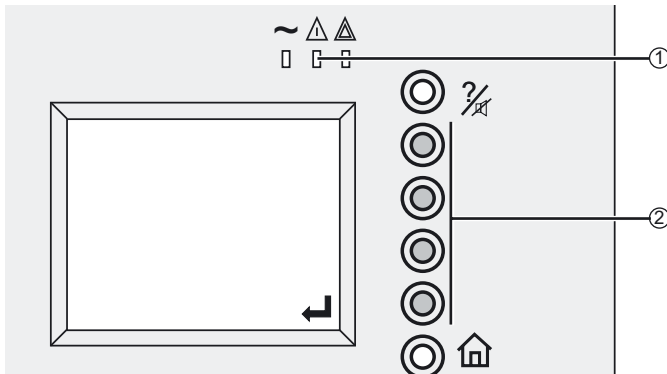

In addition to these messages, the Environment fault LED (1) goes ON and the buzzer sounds.

1- Press the Enter button (2) to display the LCM ALERT information.

Alarm details



LCM alarm details	Signification
WARRANTY SOON EXPIRED CONTACT APC: http://lcm.apc.com	Contact IT Business to extend the optimum operating period of your installation: http://lcm.apc.com
BATTERY TEST RECOMMENDED CONTACT APC: http://lcm.apc.com	The battery is approaching the end of its service life. The available backup time may be greatly reduced.
TECHNICAL CHECK RECOMMENDED CONTACT APC: http://lcm.apc.com	The parts of the product that are subject to wear should be checked.

Disable the LCM function

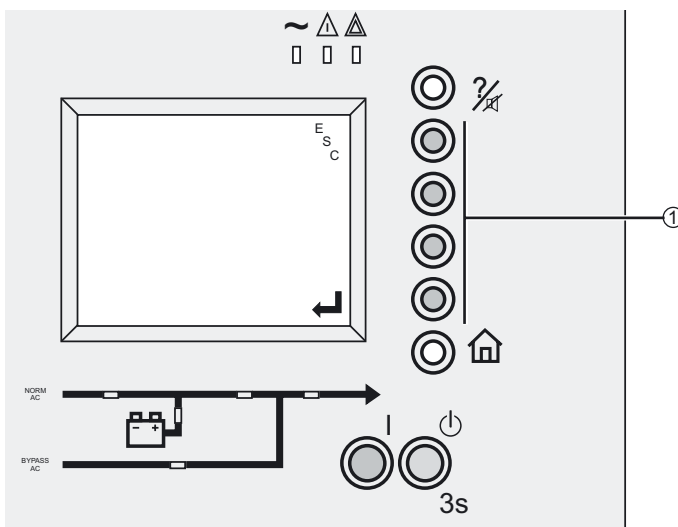

When LCM messages are displayed:

- **For temporary disabling:**
1 - Press the Abandon/ESC button

The message will be repeated twice every 30 days.

- **For complete disabling of LCM messages:**

1 - Select Disable LCM indications in the Controls menu.

Caution: You will no longer be informed of LCM events that concern your UPS if the LCM messages are disabled.

2.5 Training centres

To allow you to use APC by Schneider Electric products effectively and carry out basic maintenance, we offer a complete range of technical training courses in English and French.

IT business 50 Hz training centres:

Montbonnot Training Centre
140, Avenue Jean Kuntzmann
Innovallée
38334 - St Ismier Cedex - FRANCE

Tel: +33 (0)4 76 18 34 14
Fax: +33 (0)4 76 18 45 21

Kolding Training Centre
Silcon Allé
6000 Kolding
Denmark

Tel: +45 72190312

Shanghai Training Centre
No. 999, Shen Fu Road
Min Hang District
Shanghai 201108
P.R. China

Tel: +86 21 3407 3365
Fax: +86 21 3407 4526

Singapore Training Centre
10 Ang MO Kio Street 65, #03-06/10
Techpoint Building
Singapore 569059
Singapore

Tel: +65 6389 6792

IT business 50-60 Hz training centre:

West Kingston Training Centre
132 Fairgrounds Road
West Kingston - RI02892
U.S.A

Tel: +1 877 800 4272

Costa Mesa Training Centre
1660 Scenic Avenue
Costa Mesa - CA92626
U.S.A

Tel: +1 714 557 1637

São Paulo Training Centre
Al. Xingu, 850-Alphaville
Barueri, São Paulo
06455-030 São Paulo
Brazil

Tel: +55 11 4689-8600

Internet: <http://powerlearning.apc.com>
Catalogue and registration available on line.

3. Appendices

3.1 Available options

IP 32 option

See the "MGE™ Galaxy™ 7000 IP 32" installation manual" ref. 3460028300.

Backfeed option

This option opens the normal AC and bypass AC inputs if power fails. This option is mandatory to meet standard IEC 62040-1-2.

If an external backfeed protection system is used, it must comply with the requirements indicated in Annex L of standard IEC 62040-1-2.

External synchronisation module option

With this option, a SYNIN communications card and two circuit breakers are added to each UPS unit or static-switch unit. The external synchronisation module issues a reference frequency used to synchronise the UPS units. For more information, see document no. 34000346.

Communication options

To discover the entire range of APC by Schneider Electric products and the options available for the **MGE™ Galaxy™ 7000** range, we invite you to visit our web site at **www.apc.com**, or contact your local APC by Schneider Electric representative.

3.2 General characteristics of MGE™ Galaxy™ 7000 UPSs

UPS power in kVA	160	200	250	300	400	500						
Normal AC input												
Number of conductors	3 phases											
Reference voltage at Pn	380 V to 415 V											
Reference frequency	45 Hz to 66 Hz											
THDI	Typically 3% at Pn											
Power factor	> 0,99											
Bypass AC input												
Number of conductors	3 phases + neutral											
Reference voltage at Pn	380 V to 415 V											
Reference frequency	45 Hz to 66 Hz											
Load output												
Number of conductors	3 phases + neutral											
Set phase-to-phase voltages	380 V / 400 V / 415 V											
Set phase-to-neutral voltages	220 V / 230 V / 240 V											
Voltage variation	± 1%											
Adjustable frequencies and tolerance (on battery power)	50 Hz or 60 Hz ± 0.1 Hz											
Voltage variation for 0 to 100% load step impact	± 1%											
Permissible overloads	150% for 30 seconds, 125% for 10 minutes											
THDU Ph-to-Ph and Ph-to-N for non-linear load	< 2% Ph-to-Ph											
Battery												
Standard battery technology	Sealed lead-acid battery (gas-recombination) (Valve Regulated Lead Acid type)											
UPS power in kVA	160	200	250	300	400	500						
	PN/2	PN	PN/2	PN	PN/2	PN	PN/2	PN	PN/2	PN	PN/2	PN
Active power (kW)	72	144	90	180	112	225	135	270	180	360	225	450
Efficiency	92,0	93,2	93,0	93,0	93,2	93,8	93,5	93,6	94,1	94,1	94,3	94,3
Heat losses in kW	6,3	10,5	6,8	13,5	8,2	14,9	9,4	18,6	11,3	22,6	13,6	27,2
Heat losses in calories/s	1496	2511	1619	3238	1962	3554	2243	4449	2697	5395	3250	6501
Storage temperature range	-25°C to +45°C											
Operating temperature range at Pn	0°C to 35°C											
Relative humidity	45% to 75%											
Maximum operating altitude without derating	<1000 m											
Noise level (dBa)	75											
Product standards	IEC 62040											
Safety standards	IEC 62040-1-2											
Protection standards	IEC 62040-3											
EMC standards	IEC 62040-2											

3. Appendices

Battery characteristics >

3.3 Battery characteristics

	Sealed lead-acid battery	Vented lead-acid battery	Ni-Cd battery
Min/max number of cells	44/48	44/48	428/468
Floating voltage per cell	2.27V	2.2V	1.4V
Min/max floating voltage	600V / 654V	581V / 634V	600V / 655V
Min voltage per cell	1.65V to 1.9V	1.65V to 1.9V	Min threshold 1.1V

3.4 Glossary

Backup time	Time that the connected loads can operate on battery power.
Bypass AC source	Source supplying the bypass line. The load can be transferred to the bypass line if an overload occurs on the UPS output, for maintenance or in the event of a malfunction.
Fin	UPS input frequency (normal or bypass AC input).
Inverter	UPS module that inputs DC power and outputs AC voltage and current.
Isc	Short-circuit current
Load	Devices or equipment connected to the UPS output.
Normal (double conversion) mode	The normal UPS operating mode. The AC source supplies the UPS which in turn supplies the connected loads (after electronic double conversion).
Normal AC source	Normal source of power for the UPS.
PE	Protective conductor
PEN	Conductor serving both as a protective conductor and a neutral conductor
PFC	Sinusoidal input module used to eliminate the harmonics reinjected in the upstream source by the UPS upstream.
Relay contacts	Contacts supplying information to the user in the form of signals.
SSC	Static-switch cabinet
Uin	UPS input voltage (normal or bypass AC input).
Uout	UPS output voltage.
UPS	Uninterruptible Power System

