

InRow® Direct Expansion Air Conditioners

ACRD300 and ACCU302-AC Series

Operation and Maintenance

990-2022725-001

Release Date: 08/2022

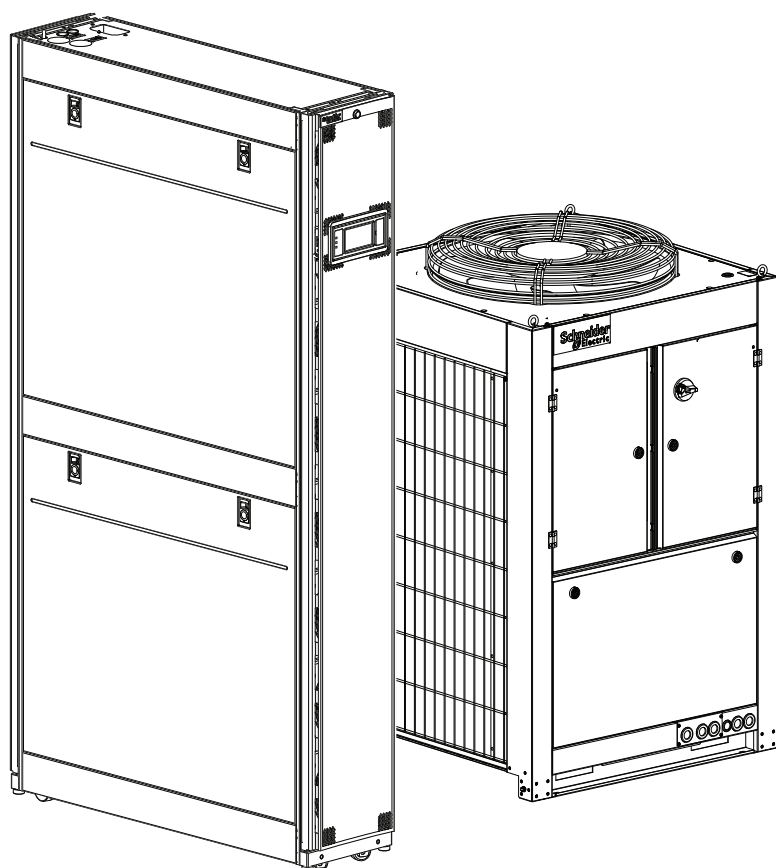

Legal Information

The Schneider Electric brand and any trademarks of Schneider Electric SE and its subsidiaries referred to in this guide are the property of Schneider Electric SE or its subsidiaries. All other brands may be trademarks of their respective owners.

This guide and its content are protected under applicable copyright laws and furnished for informational use only. No part of this guide may be reproduced or transmitted in any form or by any means (electronic, mechanical, photocopying, recording, or otherwise), for any purpose, without the prior written permission of Schneider Electric.

Schneider Electric does not grant any right or license for commercial use of the guide or its content, except for a non-exclusive and personal license to consult it on an "as is" basis. Schneider Electric products and equipment should be installed, operated, serviced, and maintained only by qualified personnel.

As standards, specifications, and designs change from time to time, information contained in this guide may be subject to change without notice.

To the extent permitted by applicable law, no responsibility or liability is assumed by Schneider Electric and its subsidiaries for any errors or omissions in the informational content of this material or consequences arising out of or resulting from the use of the information contained herein.

This manual contains general information, safety instructions, and guidance. Updates may be published from time to time and are available upon request. This manual is not a substitute for the user conducting a detailed operational and site-specific development plan.

This product is for industrial use only. It should only be used for the functions for which it has been designed as set out in this manual. User must evaluate and take adequate precautions to address risks associated with use of this product in environments and/or processes not specifically addressed in this manual (e.g. heavy industry, medical, marine environments, railway, etc.).

This product should be installed, configured, used, serviced, maintained, replaced or have similar work carried out on it only by suitably qualified, trained, experienced and competent personnel who hold any necessary authorizations (e.g. licenses, permits or certifications) to perform such work. User must ensure that all work is carried out in compliance with the manufacturer's instructions (including the product labels/markings, technical specification manual, installation manual, and operation and maintenance manual) and with all applicable laws, regulations, standards and guidance (including standards and guidance applicable to the installation location).

All work must be carried out in a way that does not give rise to danger and using appropriate personal protective equipment (PPE).

Schneider Electric shall not be responsible for any works carried out by anyone other than Schneider Electric; or for integration or use of the product with other products (including spare parts and software) that are neither approved nor provided by Schneider Electric for such purposes; or for any non-Schneider Electric software, firmware, information or memory data contained in, stored on, or integrated with this product.

To the maximum extent permitted by applicable law, neither Schneider Electric nor any of its affiliates shall be liable for any claims, costs, losses, damages, death or injuries arising out of the improper use of this product or any failure to comply with any of the above requirements. Schneider Electric's quality management system is ISO 9001 certified and the products are marked



Table of Contents

Safety.....	7
Important Safety Instructions — SAVE THESE INSTRUCTIONS.....	7
Safety During Operation.....	8
General Information.....	10
Translation Reference.....	10
Overview	10
Save These Instructions	10
Cross-Reference Symbol Used in This Manual.....	10
Manual Updates	10
Abbreviations	10
Safety Practices related to Refrigerants.....	11
Safety Valve.....	12
Canalization for Safety Valve Drainage.....	12
Pressurized Equipment.....	13
Waste Electrical and Electronic Equipment (WEEE) Disposal	13
Environmental Considerations	14
Regulation on Fluorinated Greenhouse Gases.....	14
Oil Disposal.....	14
Working Conditions and Environmental Limits	15
Radio Frequency Interference	16
R410A Refrigerant Technical Details	17
Environmental Impacts	17
Safety Classes	18
Safety and Storage.....	18
Overview	19
InRow Advantages	19
Commissioning.....	20
Overview	20
Inspection Checklists	20
Initial Inspection Checklist	20
Electrical Inspection Checklist.....	21
Mechanical Inspection Checklist	22
Display Interface Inspection Checklist	23
Start-Up Inspection Checklist.....	23
Final Inspection Checklist.....	24
Charging the Equipment.....	25
Calculating R410A Refrigerant Charge	25
Refrigerant Charging Process	26
Oil Charging Procedure.....	27
Operation	29
Display Interface.....	29
Alarm LED	29
Status LED.....	30
Link-RX/TX (10/100) LED.....	30
Using the Display.....	31
Overview Screen	31
Home Screen/Main Menu	32

Display Controls	35
Using the Path Statement	35
Changing Settings	36
First Log In	37
Logging In/Password Entry	38
Tests	39
Calibrating the Display	39
Testing Display LEDs and Annunciator	39
Testing the AFC LED	39
Unit Start Up/Shut Down	40
Start the Cooling Unit	40
Stop the Cooling Unit	40
General Configuration	41
Import and Export Unit Configuration	41
Export	41
Import	41
Cooling Unit Configuration	42
Configure the Unit	42
Cooling Group Configuration	44
Configure the Cooling Group	44
Configure Modbus	44
Interface Connection	45
A-Link Connections	46
Control the Environment	47
How the Modes of Operation Work	47
Setpoints	48
Active Flow Controller (AFC) Settings	50
Envelope Management	51
Run Hours and Service Intervals	53
Run Hours	53
Reset Run Hours	53
Service Intervals	53
User Security Settings	54
Add a New User or Edit an Existing User	54
Delete a User	54
Display Settings	54
Language, Date, Time, and Temperature	54
Screen Visibility and Audible Tones	55
Restore Defaults	55
Network Configuration	56
Configure the Network	56
TCP/IPv4 Settings	56
TCP/IPv6 Settings	56
Web Access Settings	56
FTP Server Settings	56
View Status Readings	57
Overview Screen	57
Cooling Unit Status	58
Cooling Group Status	59
Sensor Readings	59

Refrigerant System	60
Power Information	61
Input/Output States.....	61
About the Network	62
About the Unit	63
About the AFC.....	63
About the Display	63
Logs	64
Event Log	64
View Event Log.....	64
Filter Event Log	65
Clear Event Log.....	65
Data Log.....	66
Data Log Configuration	66
Export Data.....	67
Alarms.....	68
Respond to Alarms	68
View Active Alarms	68
Clear Active Alarms.....	68
Alarm Thresholds.....	68
Alarm Messages and Suggested Actions	69
Network Management Card	74
Quick Configuration	74
Overview.....	74
TCP/IP Configuration Methods.....	74
Device IP Configuration Wizard.....	75
.ini File Utility	75
BootP and DHCP Configuration	75
Command Line Interface (CLI).....	77
Access a Configured Unit.....	120
Overview.....	120
Web Interface	120
Telnet and SSH.....	121
Simple Network Management Protocol (SNMP)	121
FTP/SCP.....	122
Modbus.....	122
Recover From a Lost Password	123
Updating the Firmware.....	124
Update Display Firmware	124
Using a USB Drive to Transfer and Update Files	124
Verify Updates.....	127
Verify Success of the Transfer.....	127
Last Transfer Result Codes	127
Verify Version Numbers of Installed Firmware	127
Service Menu.....	128
Service Menu Access	128
Unit Configuration.....	128
Containment Systems.....	129
Run Hours and Service Intervals.....	131
Compressor Settings	131

Oil Return Management	132
PID Settings	133
Tune the PID Loop	135
Maintenance	137
Maintenance Mode	137
Monthly Preventive Maintenance	139
Quarterly Preventive Maintenance	142
Semi-Annual Preventive Maintenance	144
Troubleshooting	147

Safety

Important Safety Instructions — SAVE THESE INSTRUCTIONS

Read these instructions carefully and look at the equipment to become familiar with it before trying to install, operate, service or maintain it. The following safety messages may appear throughout this manual or on the equipment to warn of potential hazards or to call attention to information that clarifies or simplifies a procedure.



The addition of this symbol to a “Danger” or “Warning” safety message indicates that an electrical hazard exists which will result in personal injury if the instructions are not followed.



This is the safety alert symbol. It is used to alert the user to potential personal injury hazards. Obey all safety messages with this symbol to avoid possible injury or death.



This is the service indicator symbol. It is used to advise the user to read the technical manual.



This is the operator’s manual symbol. It is used to advise the user to read the operating instructions.

⚠ DANGER

DANGER indicates a hazardous situation which, if not avoided, **will result in death or serious injury**.

Failure to follow these instructions will result in death or serious injury.

⚠ WARNING

WARNING indicates a hazardous situation which, if not avoided, **could result in death or serious injury**.

Failure to follow these instructions can result in death, serious injury, or equipment damage.

⚠ CAUTION

CAUTION indicates a hazardous situation which, if not avoided, **could result in minor or moderate injury**.

Failure to follow these instructions can result in injury or equipment damage.

NOTICE

NOTICE is used to address practices not related to physical injury. The safety alert symbol shall not be used with this type of safety message.

Failure to follow these instructions can result in equipment damage.

Please Note

Electrical equipment should only be installed, operated, serviced, and maintained by qualified personnel. No responsibility is assumed by Schneider Electric for any consequences arising out of the use of this material.

A qualified person is one who has skills and knowledge related to the construction, installation, and operation of electrical equipment and has received safety training to recognize and avoid the hazards involved.

Always abide strictly by local laws and regulations in the place of installation.

Safety During Operation

DANGER

HAZARD OF ELECTRIC SHOCK, EXPLOSION, OR ARC FLASH

- Apply appropriate personal protective equipment (PPE) and follow safe electrical work practices.
- This equipment must be installed and serviced by qualified and trained personnel only.
- Turn off all power supplying this equipment before working on or inside the equipment.
- Replace all devices, doors, and covers before turning on power to this equipment.

Failure to follow these instructions will result in death or serious injury.

WARNING

HAZARD FROM MOVING PARTS

Keep hands, clothing, and jewelry away from moving parts. Check the equipment for foreign objects before closing the doors and starting the equipment.

Failure to follow these instructions can result in death, serious injury, or equipment damage.

WARNING

MOVING PARTS HAZARD

Do not remove rear panels if the equipment is operating.

Failure to follow these instructions can result in death, serious injury, or equipment damage.

WARNING

HAZARD TO EQUIPMENT OR PERSONNEL

All work must be performed by Schneider Electric qualified and trained personnel.

Failure to follow these instructions can result in death, serious injury, or equipment damage.

⚠ WARNING**HAZARD OF EQUIPMENT FALLING OVER**

- Use two or more persons at all times to move or turn this equipment.
- Always push, pull, or turn while facing the front and rear of this equipment. Never push, pull, or turn while facing the sides of this equipment.
- Slowly move this equipment across uneven surfaces or door thresholds.
- Lower leveling feet to floor when this equipment is at rest.
- Lower leveling feet and attach joining brackets to adjacent racks when this equipment is in final position.

Failure to follow these instructions can result in death, serious injury, or equipment damage.

⚠ CAUTION**HAZARD TO EQUIPMENT OR PERSONNEL**

Ensure that all spare parts and tools are removed from the equipment before operating.

Failure to follow these instructions can result in injury or equipment damage.

⚠ CAUTION**HAZARD OF HIGH PRESSURE REFRIGERANT OR EQUIPMENT DAMAGE**

- Use R410A refrigerant only.
- Contents are under pressure: use caution when releasing pressure in the system or refilling.
- Charging and maintaining the refrigeration circuit must only be performed by qualified and certified personnel.

Failure to follow these instructions can result in injury or equipment damage.

General Information

Translation Reference

The original version of this manual has been written in the English language.

Manuals written in other languages have been translated from the original English version.

Overview

Save These Instructions

This manual contains important instructions that must be followed during the installation and maintenance of this equipment.

Cross-Reference Symbol Used in This Manual



See another section of this document or another document for more information on this subject.

Manual Updates

Schneider Electric™ policy is one of continuous technological innovation and the company reserves the right to amend any data herein without prior notice. The images shown in this manual are for descriptive purposes only.

NOTE: Unit images and component identification information are examples only.

For any updates to this manual, please contact Schneider Electric™ providing the related part number displayed on the manual back cover.

Abbreviations

The following are abbreviations and terms used in this manual:

- EEV: Electronic expansion valve
- VFD/VSD: Variable-frequency drive/variable-speed drive
- DX: Direct expansion
- BMS: Building management system
- ATS: Automatic transfer switch
- HACS: Hot aisle containment system
- CACS: Cold aisle containment system
- RACS: Rack aisle containment system

Safety Practices related to Refrigerants

⚠ WARNING

QUALIFIED AND CERTIFIED PERSONNEL ONLY

Charging and maintaining the refrigeration circuit must only be performed by qualified and certified personnel.

Failure to follow these instructions can result in death, serious injury, or equipment damage.

Installation Area

Carry out all safety checks to minimize the risk of ignition prior to the beginning of any work on systems containing flammable refrigerants. Moreover, comply with the following requirements, prior to carrying out any work/service on the system:

- Work shall be undertaken under a controlled procedure so as to minimise the risk of a flammable gas or vapor being present while the work is being performed.
- All maintenance staff and other personnel working in the installation area shall be instructed on the nature of work being carried out. Work in confined spaces shall be avoided.
- The area shall be checked with an appropriate refrigerant detector prior to and during any maintenance and installation work, to inform the personnel about potentially toxic or flammable atmospheres.
- Ensure that the leak detection equipment being used is suitable for all applicable refrigerants, i. e. non-sparking, adequately sealed or intrinsically safe.
- If any hot work is to be conducted on the refrigerating equipment or any associated parts, appropriate fire extinguishing equipment shall be available to hand. Have a dry powder or CO₂ fire extinguisher adjacent to the charging area.
- No person carrying out work in relation to a refrigerant system which involves exposing any pipe work shall use any sources of ignition in such a manner that it may lead to the risk of fire or explosion. All possible ignition sources, including cigarette smoking, should be kept sufficiently far away from the site of installation, repairing, removing and disposal, during which refrigerant can possibly be released to the surrounding space. Prior to work taking place, the area around the equipment is to be surveyed to make sure that there are no flammable hazards or ignition risks. "No Smoking" signs shall be displayed.

Ventilated Area

Before breaking into the system or conducting any hot work, ensure that the area is in the open or adequately ventilated. A degree of ventilation shall be maintained while the work is being carried out. The ventilation should safely disperse any released refrigerant and preferably expel it externally into the atmosphere.

Detection of Flammable Refrigerants

Under no circumstances shall potential sources of ignition be used in the searching for or detection of refrigerant leaks. No halide torch (or any other detector using a naked flame) shall be used.

The following leak detection methods are deemed acceptable for all refrigerant systems:

- Electronic leak detectors may be used to detect any refrigerant leaks but, in the case of flammable refrigerants, the sensitivity may not be adequate, or may need re-calibration. (Detection equipment shall be calibrated in a refrigerant-free area.) Ensure that the detector does not represent a potential source of ignition itself, and that it is suitable for the refrigerant used. Leak detection equipment shall be set at a specific LFL percentage of refrigerant and shall be calibrated to the refrigerant employed, and the appropriate percentage of gas (25 % maximum).
- Leak detection fluids are also suitable for use with most refrigerants but the use of detergents containing chlorine shall be avoided, as the chlorine may react with the refrigerant and corrode the copper pipe-work.
- If a leak is suspected, all naked flames shall be removed/extinguished.

Safety Valve

⚠ WARNING

QUALIFIED AND CERTIFIED PERSONNEL ONLY

Charging and maintaining the refrigeration circuit must only be performed by qualified and certified personnel.

Failure to follow these instructions can result in death, serious injury, or equipment damage.

Safety valves are very fragile components.

After a unit has been installed, the safety valves inspection for signs of wear together with the cooling circuit inspection must be performed by qualified and certified personnel only.

Both the frequency and procedure of a safety valve periodical inspection need to be carried out according to the specific legal provisions currently in force in the country of installation, even after the valve expiration date stated by the supplier has passed.

If severe signs of wear are detected during the safety valve inspection, the same must be replaced.

NOTE: Before the valve expiration date, the supplier is responsible for any valve malfunctions, while once this date has passed, the same responsibility lies with the qualified and certified inspector.

Canalization for Safety Valve Drainage

⚠ CAUTION

HIGH PRESSURE REFRIGERANT

This unit contains pressurized coolant gas and water circuit; all work on pressurized circuits must be performed by qualified and certified personnel.

Failure to follow these instructions can result in injury or equipment damage.

NOTICE

QUALIFIED AND CERTIFIED PERSONNEL ONLY

- The laying of the lines and the refrigerant connections must be performed by qualified and certified personnel.
- All lines must be properly supported, insulated, and isolated to avoid premature joint failures due to system vibrations.

Failure to follow these instructions can result in equipment damage.

During the unit installation, it is necessary to canalize safety valves drainage through discharge lines to allow for relief of any refrigerant leakage into a non-hazardous area and prevent it from harming personnel or damaging equipment.



To perform safety valves drainage canalization, refer to the valves sizing data mentioned in the EN 13136 Standard and to any possibly related norm or regulation applying in the country where the installation takes place. If requested, follow any local-specific directive effective in the country of installation.

Pressurized Equipment

This appliance is subject to Pressure Equipment Directive concerning pressurized equipment. Any and all work performed on the pressure circuit must be expressly authorized by Schneider Electric and personnel must be approved by Schneider Electric. If maintenance is needed (intended as servicing work and/or components replacement), any of the following components or specific information must be sent to Schneider Electric, otherwise Schneider Electric will not guarantee a warranty coverage on the entire appliance:

- Compressors
- Liquid tanks
- Safety valves
- Cooling pressure
- Switches which need to be replaced
- Immediate notification of the serial number of the new device and of the replaced device

If it is necessary to replace any welded joint on site, Schneider Electric must be notified immediately of which joint needs repairing, and the name of the technician performing the repair work must be also notified.

Waste Electrical and Electronic Equipment (WEEE) Disposal

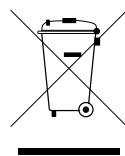

Schneider Electric products comply with international directives on the Restriction of Hazardous Substances (RoHS) in electronic and electrical equipment and the disposal of Waste Electrical and Electronic Equipment (WEEE). Dispose of any waste electronic or electrical equipment with the appropriate recycling center. Contact Schneider Electric for assistance.

At the end of an EEE (Electrical and Electronic Equipment) useful life, any battery included in the same must be removed and separated according to the instructions provided by the supplier, before disposing of the product. Used batteries must be disposed of at an appropriate waste collection center, as required by local regulations.

Environmental Considerations

Wind

The equipment is not intended for installation in areas of high wind. Consult the sales representative for information on any applicable options for installation in areas of high wind.

Earthquakes

The equipment is not intended for installation in areas at risk of seismic activity. Consult the sales representative for information on any applicable options for installation in areas at risk of seismic activity.

ATEX

The equipment is not intended for use in potentially explosive atmospheres and does not comply with Directive 2014/34 / EU (ATEX).

Dust

The equipment is not intended for use in dusty environments and in environments with conductive dust.

Corrosion

The equipment is not intended for use in a potentially corrosive environment.

Regulation on Fluorinated Greenhouse Gases

According to Regulation (EU) No. 517/2014 on fluorinated greenhouse gases, operators of stationary equipment that contain fluorinated greenhouse gases shall ensure that the recovery of those gases is carried out by natural persons that hold the relevant certificates provided for by Article 10, so that those gases are recycled, reclaimed or destroyed.

NOTE: 'Recovery' means the collection and storage of fluorinated greenhouse gases from products, including containers, and equipment during maintenance or servicing or prior to the disposal of the products or equipment.

Oil Disposal

Refrigerant oil is harmful to the environment, therefore it must be properly recycled or disposed of, according to 2008/98/EC (Water Framework Directive).

- Collect the oil from the unit by draining it until it is no longer flowing. Be aware that oil recovered from an air-conditioning equipment may contain halogens.
- Measure and record the quantity of recovered waste oil, then pour it into a suitable 208 liters container. Do not fill containers over 90% of their capacity and leave the remaining 10% for expansion.

NOTE: Do not mix refrigerant oil with waste oils.

- If the appliance is being dismantled, store waste oil containers in a diked area or in a containment vessel, until the dismantling procedure is completed.
- Once the waste oil collection has been completed, contact a licensed waste oil company for pick up.

Working Conditions and Environmental Limits

Uniflair Direct Expansion InRow units have a minimum heat load to ensure proper operation. Failure to operate the unit with at least the minimum load will result in one or more of the following conditions:

- Unstable unit operation
- Decreased operating efficiency
- Equipment on/off cycling
- Inadequate dehumidification
- Increased wear and tear caused by frequent on/off cycles
- Decreased group control effectiveness
- Potential increase in cost of ownership

Limit Working Conditions—Indoor Units (ACRD301P, ACRD301S)	
Refrigerant type	R410A
Voltage input tolerance	±10%
Approximate minimum recommended load	8.0 kW (27,297 BTU/hr)
Outdoor ambient temperature without the low ambient temperature kit installed	Down to –15°C (+5°F) Up to 48°C (118°F)
Outdoor ambient temperature with the low ambient temperature kit installed	Down to –40°C (–40°F) Up to 48°C (118°F)
Ambient %RH	5 to 80%RH
Altitude	3000 m (9843 ft)
Storage Conditions	
Temperature	–25°C to +65°C (–13°F to +149°F)
Humidity	5 to 95%RH

NOTE: ACRD301P and ACRD301S are in accordance with the Electromagnetic Compatibility Standard (EMC): EN 55032, EN55024, EN61000-3-2, EN61000-3-3, EN61000-6-3, EN61000-6-1, EN61000-3-11, EN 61000-3-12. ACRD301P and ACRD301S are in accordance with FCC: ANSI C63.4.

NOTE: The SKUs comply with EN61000-3-12 provided that the short-circuit power SSC is greater than or equal to 350 at the interface point between the user supply and the public system. It is the responsibility of the installer or user of the equipment to ensure, by consultation with the distribution network operator if necessary, that the equipment is connected only to a supply with a short-circuit power SSC greater than or equal to 350.

Limit Working Condition-Outdoor Units	
Refrigerant type	R410A
Operating outdoor temperature	–40°C to +46°C (–40F to +115°F)
Altitude	3000 m (9843 ft)
Storage Conditions	
Temperature	–25°C to +65°C (–13°F to +149°F)
Humidity	5 to 95%RH

NOTE: ACCU302-AC is in accordance with the Electromagnetic Compatibility Standard (EMC): EN 55032, EN55024, EN61000-3-2, EN61000-3-3, EN61000-6-3, EN61000-6-1, EN61000-3-11, EN 61000-3-12.

NOTE: The SKUs comply with EN61000-3-12 provided that the short-circuit power SSC is greater than or equal to 350 at the interface point between the user supply and the public system. It is the responsibility of the installer or user of the equipment to ensure, by consultation with the distribution network operator if necessary, that the equipment is connected only to a supply with a short-circuit power SSC greater than or equal to 350.

Radio Frequency Interference

NOTE: The Radio Frequency Interference directive applies to units installed in US and in Canada only.

Cooling units comply with part 15 of the FCC Rules. Operation is subject to the following two conditions:

1. These devices may not cause harmful interference.
2. These devices must accept any interference received, including interference that may cause undesired operation.

Any changes or modifications not expressly approved by the party responsible for compliance could void the user's authority to operate the equipment.

R410A Refrigerant Technical Details

The refrigerant R410A is a blend of non-ozone-depleting HFC refrigerants (R32 50% and R125 50%). R410A, due to its thermodynamic properties, has high efficiency due to the negligible amount of glide and subsequent energy losses during the change of state phases. Technicians should ensure they are equipped with the correctly rated gauges for R410A. Although R410A is sometimes referred to as an azeotrope, we recommend that it should always be removed from the cylinder as a liquid when charging a system. R410A is not compatible with mineral oil, and it is recommended the use of a polyolester (POE) oil.

The recovery of R410A is mandatory under Regulation n°517/2014.

Environmental Impacts

Synthetic refrigerants contribute to global warming increase. The refrigerants listed below feature low global warming potential (GWP). This is possible due to their thermodynamic properties.

Environmental Impact Parameters

Parameters have been established to determine the environmental impact of different kinds of refrigerant:

- O.D.P. (Ozone Depletion Potential) can register a value between 0 and 1 (CFC-R12 = 1).
- G.W.P. (Global Warming Potential) is the relationship between the overall warming caused by a particular substance and the one caused by CO₂ carbon dioxide.

It is important to consider not only the direct environmental impact of the refrigerant (due to the chemical-physical properties) but the indirect impact as well (i.e., its effect on cooling machinery throughout the operative life).

About 15% of the world's electricity is used to power refrigerant and air conditioning systems. Inefficient use of energy in these applications is a waste of valuable resources and contributes to global warming. People usually ignore the fact that most of the global warming effect caused by refrigerating systems comes from generating energy to power them, and only a small proportion comes from the release of certain refrigerant such as HCFCs or HFCs.

As a general consideration, refrigerant losses should be minimized.

NOTE: For completeness, a variety of refrigerants is listed in this table. Refer only to the refrigerants with which the unit operates.

Refrigerant	Type	Safety Class	O.D.P.	PED Group	GWP*	GWP**
R134a	HFC	A1	0	2	1430	1300
R513A	HFC	A1	0	2	631.4	573
R1234ze	HFO	A2L	0	2	7.0	<1.0
R1234yf	HFO	A2L	0	1	4.0	<1.0
R410A	HFC	A1	0	2	2088	1920
R407C	HFC	A1	0	2	1774	1869
R22	HFC	A1	0	2	1810	1760
R454B	HFO	A2L	0	1	466	–
R452B	HFO-HFC	A2L	–	1	676	467
R32	HFC	A2L	0	1	675	677

*Calculated according to European F-Gas regulation N° 517/2014.

**Data from IPCC Assessment Report V (AR5)

Safety Classes

Each refrigerant is assigned to one of three classes (1, 2, or 3) and one optional subclass (2L), based on lower flammability limit testing, heat of combustion, and the optional burning velocity measurement.

- Safety class A1: Refrigerants belonging to this class do not feature any propagation of flame at 60°C air temperature and atmospheric pressure.
- Safety class A2: Refrigerants belonging to this class are slightly flammable and feature a low flammability limit higher than 0.10 kg/m³ at 60°C air temperature and atmospheric pressure, and a combustion heat lower than 19.000 kJ/kg.
- Safety class A2L: Refrigerants belonging to this class are slightly flammable and feature a low flammability limit higher than 0.10 kg/m³ at 60°C air temperature and atmospheric pressure, and a combustion heat lower than 19.000 kJ/kg and a maximum burning velocity of 10 cm/s.
- Safety class A3: Refrigerants belonging to this class are extremely flammable and feature a low flammability limit lower than 0.10 kg/m³ at 60°C air temperature and atmospheric pressure. Even those refrigerants featuring a combustion heat of 19.000 kJ/kg belong to this flammability class.

Safety and Storage

Toxicity

All refrigerants have undergone extensive toxicity testing and are considered safe for their intended refrigeration and air-conditioning applications, whenever used in accordance with applicable guidelines and standards.



Refer to the EN 378-1 regulation for specific information related to each refrigerant toxicity.

Material Safety Data Sheet (MSDS)

Schneider Electric recommends reading the Material Safety Data Sheet (MSDS) before using the product. All refrigerants are registered under the European Union REACH regulation (Registration, Evaluation, Authorization, and Restriction of Chemicals).

Overview

The ACRD300 series of indoor units can provide a cooling capacity up to 30 kW based on a half-rack platform (300 mm (12 in.)) with an ACCU302-AC outdoor condensing unit.

This modular, row-based computer room cooling system offers efficient, predictable, and economical cooling for a variety of spaces.

Critical environmental requirements now reach far beyond the confines of the traditional data center or computer room to encompass a larger suite of applications, referred to as technology rooms. Critical environment applications include the following:

- Computer rooms
- Telecommunication facilities
- Clean rooms
- Power equipment
- Medical equipment rooms
- LAN/WAN environments
- Edge data centers
- Traditional data centers

InRow Advantages

The row-based solution improves energy efficiency and cooling capacity in a number of ways. First, the Uniflair™ Direct Expansion InRow unit draws air directly from the hot aisle, taking advantage of higher heat transfer efficiency due to higher temperature differences. It can then discharge room-temperature air directly in front of the servers or IT applications installed in the room. The In-Row configuration allows the unit to operate at higher return and supply air temperatures, reaching 100% sensible capacity. This significantly reduces the need for humidification.

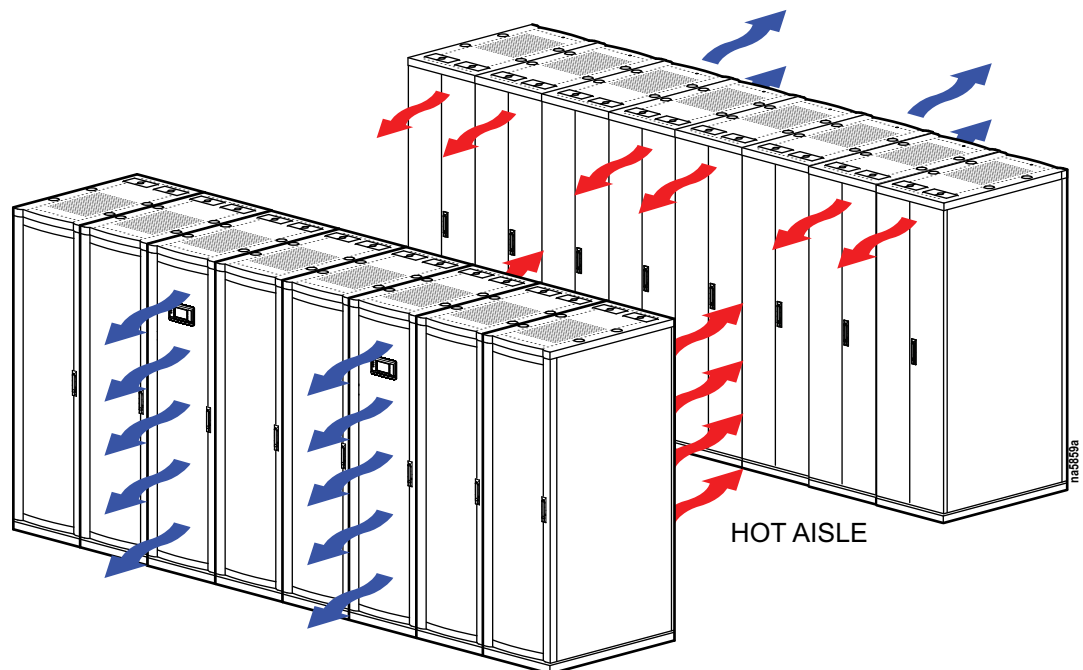

Commissioning

After installation, verify that all components are working properly and the equipment is ready to begin operation.

Overview

In order to complete commissioning, make sure that the following procedures has been done.

1. Complete the following inspections:
 - Initial
 - Electrical
 - Mechanical
 - Display interface
 - Start-up
 - Final
2. Check the refrigerant charge in the system and add refrigerant if needed (see [Charging the Equipment](#), page 25).
3. Charge the system with oil (see [Oil Charging Procedure](#), page 27).

Inspection Checklists

Initial Inspection Checklist

⚠ WARNING

DAMAGE TO EQUIPMENT AND PERSONNEL

Do not run service utilities in front of the fan outlet.

Failure to follow these instructions can result in death, serious injury, or equipment damage.

The initial inspection ensures that the equipment has been properly installed. The location of the cooling unit has been properly prepared and the cooling unit is free of damage.

NOTE: The vapor barrier minimizes moisture infiltration. Without a vapor barrier, it will be difficult to maintain the humidity in the room. Do not introduce unconditioned outside air into the space.

Ensure that

- The installation procedure is complete according to the requirements of the installation manual and local codes.
- The walls, floor, and ceiling of the room where the cooling unit is located are sealed with a vapor barrier.
- There is no evidence of damage to the cooling unit.
- Clearance around the equipment is in accordance with CE, local, and national codes as well as the installation manual.
- The cooling unit is level and joined to the adjacent racks.
- The cooling unit is not installed at the open end of a row.

Electrical Inspection Checklist

⚠️⚠️ DANGER

HAZARD OF ELECTRIC SHOCK, EXPLOSION, OR ARC FLASH

- Apply appropriate personal protective equipment (PPE) and follow safe electrical work practices.
- This equipment must be installed and serviced by qualified and trained personnel only.
- Turn off all power supplying this equipment before working on or inside the equipment.
- Replace all devices, doors, and covers before turning on power to this equipment.

Failure to follow these instructions will result in death or serious injury.

⚠️⚠️ WARNING

ELECTRICAL HAZARD

- Electrical service must conform to local and national electrical codes and regulations.
- The equipment must be grounded.

Failure to follow these instructions can result in death, serious injury, or equipment damage.

The electrical inspection verifies that all electrical connections are secure and correct and that the equipment is properly grounded.

Ensure that

- Incoming voltages match the phase and voltage rating on the nameplate.
- Electrical wiring complies with local and national codes and regulations.
- Equipment is properly connected to an earth ground.
- Front and rear doors for the indoor unit and doors for the outdoor are properly grounded.
- Internal electrical components and terminal blocks do not have any loose connections.
- Electrical connections are tight, including contactors, terminal blocks, controllers, switches, relays, auxiliary devices, and field connections.
- The primary and secondary power feeds (if applicable) are properly connected.
- Circuit breakers are correct and securely attached to the DIN rail.
- The rack temperature sensors are installed correctly for InRow and CACS modes.
- The optional rope water detection device is installed properly.
- The temperature and humidity sensors are connected correctly.



See the *Installation Manual* for the unit for installation procedures.

Mechanical Inspection Checklist

⚠ CAUTION

HAZARD TO EQUIPMENT OR PERSONNEL

- The equipment is shipped from the factory with a nitrogen holding charge. Remove the nitrogen holding charge using the service ports located on the internal refrigerant piping.
- Improperly installed piping may result in improper operation and possible damage to the cooling unit or surrounding equipment.

Failure to follow these instructions can result in injury or equipment damage.

The mechanical inspection verifies that all mechanical components and connections are secure and tight and ready for start-up. The inspection ensures that field piping is properly installed to promote oil return to the compressor.

Ensure that

- The condensate drain line is the size of the drain connection and has proper slope away from the unit.
 - Mechanical connections are tight, including refrigerant piping and the condensate drain line.
 - Refrigerant piping size is correct according to the line size table in the installation manual.
 - Vertical, horizontal, and total run lengths are recorded for liquid and gas lines.
 - Field-installed traps and piping are in accordance with the installation manual and follow proper piping practices.
 - The number of 45- and 90-degree bends in the refrigerant piping are recorded.
 - Room conditions comply with the operating guidelines before starting the equipment.
 - Covers and guards are in place.
 - Piping is adequately supported and isolated when necessary.
 - Piping in the building and on the roof is properly insulated.
 - Piping has been leak tested and held a vacuum prior to introduction to refrigerant into the system.
- Indoor units: Check that the indicator paper in the sight glass is a green color.
- Field-installed service valves are open.

Display Interface Inspection Checklist

The display interface inspection verifies that the sensors and internal communication links are installed properly. Check that the cooling unit is connected to the other cooling units in the room if you are using cooling group controls.

Ensure that

- An A-Link bus is connected to each cooling unit and a terminator is plugged into all unused A-Link connections.
- The input contacts and output relays are connected correctly.
- The building management system is connected correctly and a terminator is wired into the final cooling unit between Modbus D0 and Modbus D1.
- The network port is connected correctly and an IP address has been assigned to the equipment.

Start-Up Inspection Checklist

The start-up inspection ensures that the equipment is operating properly after the initial start-up. This inspection verifies that all modes of operation are working correctly and that the cooling unit is ready for normal operation.

While the equipment is operating, ensure that

- The cooling unit is free from malfunctions, including water leaks, unusual vibrations, or other irregularities in each mode of operation.
- Air filters are clean and free of debris. Replace air filters if necessary.
- If applicable, perform an air balance to verify that the fans are set to the desired fan speed.
- If equipped, the condensate pump is working properly by adding fresh clean water to the condensate pan and checking pump operation.
- Temperature and humidity sensors are working properly.
- Compressor suction and discharge pressures are within normal range.
- The compressor oil level is at least 1/3 full.
- The cooling unit has the proper refrigerant charge for year-round operation.
- The high-pressure switch is operating correctly.
 1. Shut down the condenser fan.
 2. The head-pressure will rise until the high-pressure switch shuts down the compressor.
 3. Record the shut-off point.

Final Inspection Checklist

The final inspection verifies that the system is clean, the installed options work properly, and the start-up form is sent to Schneider Electric.

Ensure that

- Interior and exterior of the equipment are clean and free from debris and loose hardware.
- Internal protective covers and hardware are installed.
- Packaging materials are disposed of properly.
- There are no active alarms.
- Customer is trained on the user display and is able to view active alarms and status readings.
- The customer is given the technical support contact number applicable for their region.
- Unit documentation has been given to the customer.
- Start-up form is filled in and sent to Schneider Electric.

Charging the Equipment

⚠ WARNING
<p>HAZARD TO EQUIPMENT OR PERSONNEL</p> <p>All work must be performed by Schneider Electric qualified and trained personnel.</p> <p>Failure to follow these instructions can result in death, serious injury, or equipment damage.</p>

⚠ CAUTION
<p>HAZARD OF HIGH PRESSURE REFRIGERANT OR EQUIPMENT DAMAGE</p> <ul style="list-style-type: none"> • Use R410A refrigerant only. • Use hose and manifold set suitable for R410A with a minimum pressure rating of 50 bar (725 PSIG). • The unit display should be used to obtain pressure readings. <p>Failure to follow these instructions can result in injury or equipment damage.</p>

Calculating R410A Refrigerant Charge

The total system charge has to be adjusted based on the liquid line length as shown in the table below.

ACR Tube Sizing – in.	Wall Thickness – mm	Cross-Section – mm ²	Refrigerant Charge – kg/m (lb/ft)
1/2	0.89	94	0.094 (0.063)
5/8	1.02	150	0.151 (0.101)
3/4	1.07	224	0.226 (0.151)
7/8	1.14	312	0.314 (0.211)

Refrigerant Charging Process

R410A is a mixed refrigerant. When charging this equipment with mixed refrigerant, only liquid refrigerant must be used.

NOTE: The equipment must be charged only with R410A refrigerant. The installing contractor is responsible for providing sufficient refrigerant for a complete system charge during start-up.



See *Component Identification* section in the *Installation Manual* for the location of service ports.

1. Pressurize the system to 17.2 bar (250 PSI) with nitrogen (use the service and discharge ports). Leave the system pressurized for 24 hours then check the gauges for a drop in pressure.
2. Use a vacuum pump and pull the first vacuum down to 750 microns (use the vacuum ports on the connection piping). The initial pull-down can take up to 24 hours.
3. Once the vacuum level has reached 750 microns, close the manifold gauge valves and turn off the vacuum pump. Wait for one hour (the vacuum should not rise above 1500 microns) and then break the vacuum with nitrogen gas (use the service and discharge ports) until the system pressure equals atmospheric pressure.
4. Pull a final vacuum down to 300 microns for a minimum of two hours.
5. Charge with liquid R410A refrigerant through the service port and needle valve on the condenser until the pressure equalizes with the refrigerant canister.
6. Open the ball valves and start the system. Charge the refrigerant slowly through the suction.

Oil Charging Procedure

⚠ WARNING

HAZARD TO EQUIPMENT OR PERSONNEL

All work must be performed by Schneider Electric qualified and trained personnel.

Failure to follow these instructions can result in death, serious injury, or equipment damage.

NOTICE

DAMAGE TO EQUIPMENT

Do not charge the compressor with too much oil: compressor damage could result. The only way to drain oil from the compressor is to remove the compressor from the equipment. The following system damage could also occur:

- Failure of valves and pistons due to oil slugging.
- Excessive oil carryover.
- Loss of evaporator performance due to oil level build-up in the low-pressure side of the system.

Failure to follow these instructions can result in equipment damage.

The system must be field-charged with 600 ml (20 oz) of PVE oil to make sure the system functions normally.

In installations with good oil return and line runs up to 15 m (49 ft), no additional oil above the initial 600 ml (20 oz) of oil is required. If the installation lines exceed 15 m (49 ft), additional oil may be needed. 1% or 2% of the total system refrigerant charge can be used to calculate the required oil. Regardless, the oil charge has to be adjusted based on the oil level in the compressor sight glass: the oil level must be no lower than 1/3 in the sight glass when the compressor is running.

Use the following oil type:

- PVE (Daphne Hermetic Oil FVC32D)

Use the following calculations to get the total charge amount:

- **Metric**

Total oil charge in ml = 600 ml + (charge in kg) * 0.02 * 1000

◦ Example: Charge = 25 kg

$$600 \text{ ml} + (25 * 0.02 * 1000) = 600 + 500 = \mathbf{1100 \text{ ml}}$$

- **US Standard**

Total oil charge in oz = 20 oz + [(charge in lb)/2.2046] * 0.02 * 33.8

◦ Example: Charge = 55.1 lb

$$20 \text{ oz} + (55.1/2.2046) * 0.02 * 33.8 = 20 + (25 * 0.02 * 33.8) = 20 + 16.9 = \mathbf{36.9 \text{ oz}}$$

NOTE: This image is an example only. The unit in use may differ.

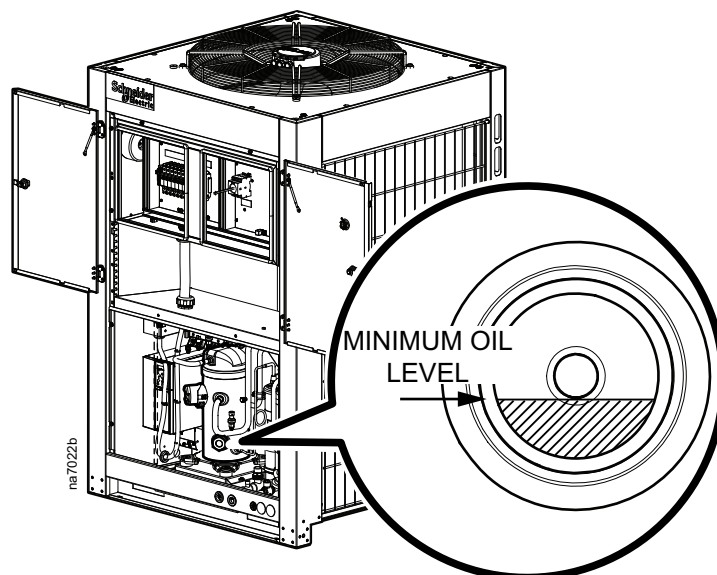

1. Prepare to add oil:
 - a. Use a new sealed oil can and a manual oil pump. The pump hose must be sized for 1/4 in. flare fittings and must include a valve depressor at its end, which will open the valve on the suction port of the compressor.
 - b. Use Daphne Hermetic PVE Oil FVC32D. Any other oil must be approved by Schneider Electric before using.
2. Purge the pump and hose
 - a. Ensure that the oil pump is clean. Insert the pump in the oil container and make sure that the container is open to the atmosphere for as short a period of time as possible. When available, use a plug adapter kit to further reduce the exposure of the oil to the atmosphere.
 - b. Bleed all air from the pump and hose with a few strokes of the pump. Purging the pump removes the moisture-saturated oil left inside the hose from previous usage.
 - c. Connect the hose to the suction port of the compressor immediately after purging to avoid moisture contamination.
3. While the equipment is running, charge 600 ml (20 oz) PVE oil through the suction port. Pump the oil very slowly. (This is to ensure the oil separator is functioning properly.)
4. Other than the amount required for the oil separator, no additional oil should be required. Let the compressor run at full capacity for at least one hour and check the oil level in the oil sight glass. The level should be between 1/3 and 2/3 full, or within the limit shown on the oil level sticker. If the oil is not within the acceptable limit, check the oil return line for restrictions. When oil is flowing properly, the oil return line should feel warm to the touch.

NOTE: Dispose of the oil waste appropriately.

Operation

Display Interface

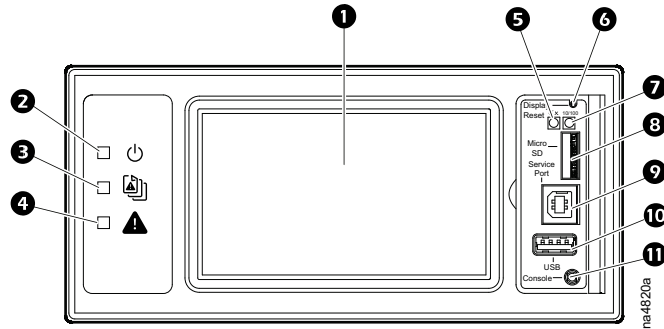

Item	Description	Function
1	LCD Display	4.3-inch touch-screen color display
2	Power LED	The cooling unit is powered when the LED is illuminated. Unit firmware is updating when LED is blinking.
3	Check Log LED	When this LED is illuminated, a new entry has been made to the event log.
4	Alarm LED	Displays current alarm condition of unit.
5	Status LED	Displays current network management card status.
6	Display Reset button	Resets the display microprocessor. This has no effect on the air conditioner controller.
7	Link-RX/TX (10/100) LED	Displays current network link status.
8	Micro SD card slot	Memory card expansion slot.
9	Service port	USB-B port used only by service personnel.
10	USB-A port	Supports firmware upgrades.
11	Serial Configuration port	Connects the display to a local computer to configure initial network settings or access the command line interface (CLI).

Alarm LED

This LED indicates active alarms on the display.

Condition	Description
Off	No alarm
Solid yellow	Warning alarm
Solid red	Critical alarm

Status LED

This LED displays current network management card status and display status.

Condition	Description
Off	One of the following situations exist: <ul style="list-style-type: none"> The display is not receiving input power. The display is not operating properly. It may need to be repaired or replaced. Contact Schneider Electric Customer Support.
Solid green	The display has valid TCP/IP settings.
Solid orange	A hardware malfunction has been detected in the display. Contact Schneider Electric Customer Support.
Flashing green	The display does not have valid TCP/IP settings.
Flashing orange	The display is making BOOTP requests.
Alternately flashing green and orange	If the LED is flashing slowly, the display is making DHCP requests. If the LED is flashing rapidly, the display is starting up.

Link-RX/TX (10/100) LED

This LED indicates the network status of the display.

Condition	Description
Off	One or more of the following situations are occurring: <ul style="list-style-type: none"> The display is not receiving input power. The cable or device that connects the cooling unit to the network is disconnected or not functioning properly. The display itself is not operating properly. It may need to be repaired or replaced. Contact Schneider Electric Customer Support.
Solid green	The display is connected to a network operating at 10 megabits per second (Mbps).
Solid orange	The display is connected to a network operating at 100 Mbps.
Flashing green	The display is receiving or transmitting at 10 Mbps.
Flashing orange	The display is receiving data packets at 100 Mbps.

Using the Display

The display initializes and runs a LED test when power is applied to the cooling unit.

Overview Screen

After start-up, the display shows an overview screen containing basic status information. Press **Home** to toggle between the main menu and overview screen. After a period of inactivity, the display reverts back to the overview screen.

NOTE: To maintain cleanliness and optimal performance of the touch-screen surface, it is recommended to use a soft-tip stylus when using the display. Never use sharp or hard-pointed objects on the touch-screen surface.

NOTE: Images are examples only to show operation of the display interface. Screens on your unit may vary.

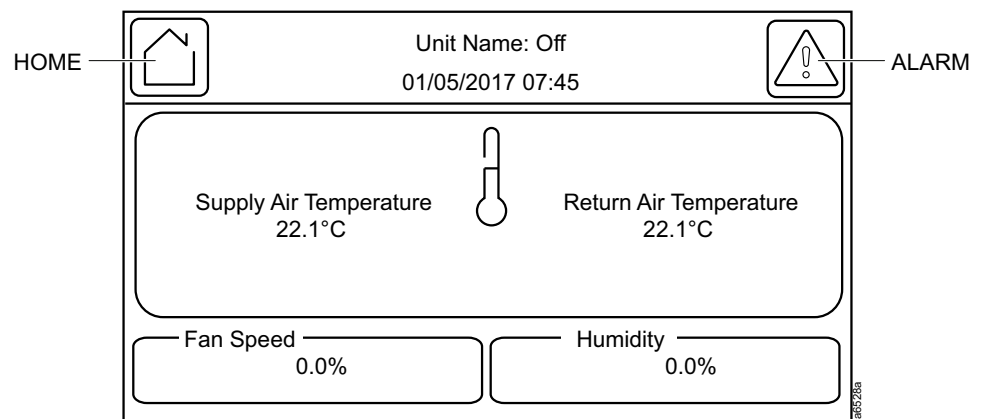

Home Screen/Main Menu

At any time during operation, press **Home** to return to the main menu. While on the main menu, press **Home** to toggle between the home and overview screen. To view active alarms, press **Alarms**.



See Alarms, page 68 for more information.

The **Alarms** button changes based on the current state of the unit.

Symbol	Description
	No alarms: No alarms are present.
	Informational: Provides details on an alarms that are not a warning or critical.
	Warning: An alarm condition requires attention and could jeopardize your data or equipment if its cause is not addressed.
	Critical: A critical alarm exists, which requires immediate action.

Main menu options appear on the display as shown in the example below.

NOTE: Menus will vary depending on unit type.

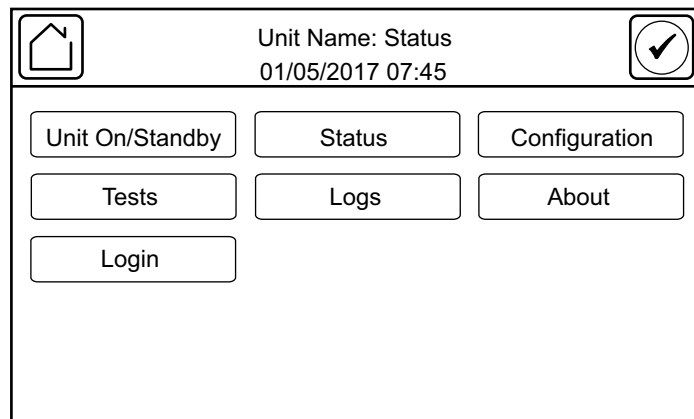

Menu Description

- **ON/Off:** The **On/Off** screen is used to turn the unit on or off and configure operational settings for the unit.



See Unit Start Up/Shut Down, page 40.

- **Status:** Contains menus with sensor reading information, unit operation information, runtimes and counters, and component information.



See View Status Readings, page 57.

- **Configuration:** Contains menus for user-configurable settings for the unit and network. The **Service** menu is also located here.

- **Unit:** Contains menus for configuring the operational behavior of the cooling unit.



See Cooling Unit Configuration, page 42.

- **Group:** Contains menus for configuring the operational behavior of the cooling group.



See Cooling Group Configuration, page 44.

- **Containment Systems:** Contains settings related to the AFC.



See Active Flow Controller (AFC) Settings, page 50.

- **Service:** Contains menus for configuring the unit and manually controlling components for servicing. This menu is to only be accessed by qualified service personnel.



See Service Menu, page 128.

- **Display:** Contains menus for display settings, user preferences, and user access.



See Display Settings, page 54.

- **Network:** Contains menus for configuring the network settings.



See Configure the Network, page 56.

- **Modbus:** Contains settings to configure Modbus TCP settings.



See Configure Modbus, page 44.

- **Restore Defaults:** Contains options to restart the display.



See Restore Defaults, page 55.

- **Tests:** Contains menus to calibrate the touch screen and test the display LEDs.



See Tests, page 39.

- **Logs:** These screens save status information and record events and configuration changes.



See Logs, page 64.

- **About:** These screens display identifying information that is helpful when obtaining service.



See About the Network, page 62, About the Unit, page 63, and About the Display, page 63

- **Login/Logout:** Used to log into or log out of the unit.



See Logging In/Password Entry, page 38.

Display Controls

To view a sub-menu, select an option from the main menu. Continue this process until the appropriate menu is active.

During navigation, the current file path is displayed at the top of the screen. Clicking on any of the headers reverts the display to the specified menu.

Menus with multiple pages use arrows to move between pages. **Forward** and **Back** advance one page at a time while **First** and **Last** move directly to the first or last page within the menu. Once changes have been made within a menu, press **OK** to confirm changes or **ESC** to cancel.

NOTE: Images are examples only to show operation of the display interface. Screens on the unit in use may differ.

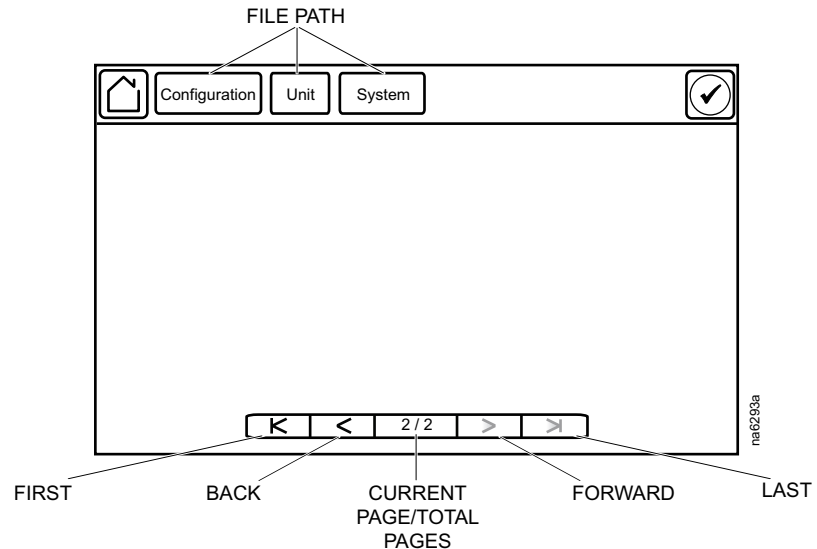

Using the Path Statement

Select the main- and sub-menu options specified in the path statement to view or configure a setting. The path statement lists the main- and sub-menu options you select to navigate to the setting you want to view or modify. The parts of the path statement are defined in the following example:

Path: Main > Status > Unit Overview

Main > Your starting point is the main menu.

Status > Select this option from the main menu.

Unit Overview > Select this option from the sub-menu.

Subsequent options are listed and defined under the path statement.

Changing Settings

NOTE: Images are examples only to show operation of the display interface. Screens on your unit may vary.

Screens that have mixed types of settings (e.g. list items and field items) require changes to be confirmed individually after being changed.

1. Select the option or enter a value for the setting to be changed.
 - a. For list items ❶, press the up and down arrows to select the setting.
 - b. For field items ❸, enter a value for the setting.
2. Press **OK** ❷ to confirm after each individual setting change.

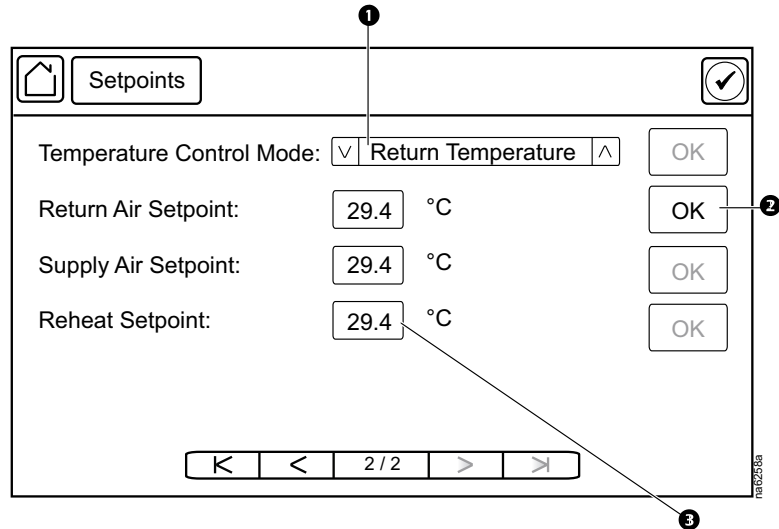

Screens that only contain field items can be confirmed together with a single **OK** button.

1. Enter a value for any or all field items ❶.
2. Press **OK** ❷ to confirm all changes at once, or press **ESC** to exit without accepting changes ❸.

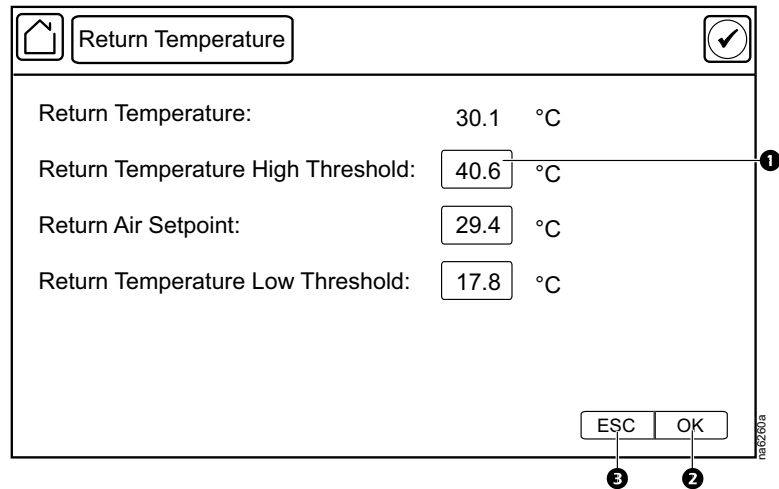

First Log In

The first time you log in to the unit at the display interface, you will be prompted to enable the device account. You can connect to the Network Management Card to enable the account and set the password in any of the following ways :

- HTTPS



See *Web Interface*, page 120 for information on accessing the Web interface. See the *Online Guide* for your unit, available from the Schneider Electric Web site (www.se.com), for more information on the Web interface.

- SSH



See *Telnet and SSH*, page 121 for information on connecting through Secure Shell.

- Console port



See *Command Line Interface (CLI)*, page 77 for information on connecting through the console port on the display interface.

Logging In/Password Entry

Path: Main > Login

The unit display interface requires password verification before settings can be altered on the unit. You can log in from the main menu by selecting **Login**. While it is not required to log in to view unit configurations, it is required to make any changes.

1. Select **Login**.
2. Select your login ID with the up and down arrows ❶.
 - NOTE:** The default user ID is `apc`.
3. Enter your password in the **Pin** field ❷ with the keypad.
 - NOTE:** The default password is `1234`.
4. Select **Enter** ❸.

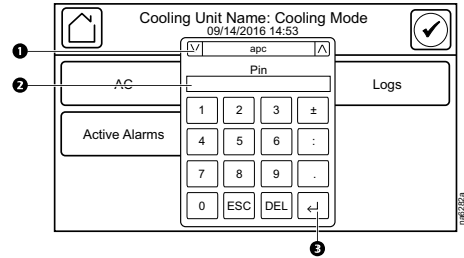

If the password was not entered from the **Login** screen on the main menu, you will be prompted to enter the password when attempting to change a setting. The unit default password is `1234`.



See for information on editing users and passwords.

The **Home** button visually changes to signify that a user is currently logged in.

Symbol	Description
--------	-------------



Home when the system is locked.



Home when the system has been unlocked by a user.

After the password is entered, user login remains active until the period of inactivity exceeds the **Auto Logoff** setting.



See Screen Visibility and Audible Tones, page 55.

Tests

Calibrating the Display

Path: Main > Tests > Display Calibration > Calibrate

Use this screen to calibrate the touch screen by touching the center of the box that appears on the screen. When you are satisfied with the calibration, let the timer run down to zero.

NOTE: The touch screen will need to be calibrated every time the firmware on the touch screen is updated.

Path: Main > Tests > Display Calibration > Calibration Check

Use this screen to test the accuracy of the touch screen calibration by touching the center of the box that appears on the screen. When you are satisfied with the test, let the timer run down to zero.

NOTE: The touch screen will need to be calibrated every time the firmware on the touch screen is updated.

Testing Display LEDs and Annunciator

Path: Main > Tests > Annunciators

1. Press **Start** to test the display LEDs and annunciator.

The display LEDs will cycle through a green, orange, and red illumination pattern and the annunciator will sound.

2. Press **Stop** to stop testing.

Testing the AFC LED

Path: Main > Configuration > Service > Containment Systems

1. Select **On** for **Active Flow Control Lamp Test** and press **OK** to test the Active Flow Controller (AFC) LED.

The AFC LED will cycle through a red, green, and blue illumination pattern.

2. Select **Off** for **Active Flow Control Lamp Test** and press **OK** to stop the LED test.

Unit Start Up/Shut Down

Start the Cooling Unit

IMPORTANT: The unit must be powered on for at least six hours before the first startup to ensure that liquid refrigerant has not accumulated in the compressor sump and that the electrical box and receiver body are heated.

Path: Main > On/Off

1. Select **On** for **Unit**.

If you are not logged in and **Protect On/Standby** is activated, a prompt will appear to enter your password.

NOTE: **Protect On/Standby** can be enabled under **Main > On/Off**. The default setting is **Disable**.

2. Enter your password if required.

The header will now display **Unit Name: Active**.

3. Select the option for **Unit Role Override**:

- **Automatic:** Allows the system to select the role of the cooling unit.
- **Forced On:** Select **Enable** if **Runtime Balancing Enable** is selected and you DO NOT want a particular unit in the group to become a backup unit.

The cooling unit will run according to the configured settings.

NOTE: The **Unit** setting only affects the local cooling unit. You must set the **Unit** option for each cooling unit in the cooling group.

NOTE: The **Standby Input** must also be inactive in order to leave the Standby state.

If the **Protect On/Standby** option has been selected, you will be prompted to enter the device password before a change can be made to the **Unit** setting.

Stop the Cooling Unit

DANGER

HAZARD OF ELECTRIC SHOCK, EXPLOSION, OR ARC FLASH

The **Off** option does not remove power from the cooling unit. You must disconnect power at the mains to remove power from the cooling unit.

Failure to follow these instructions will result in death or serious injury.

Path: Main > On/Off

1. Select **Off** for **On/Off**.

If you are not logged in, a prompt will appear to enter your password.

The header will now display **Unit Name: Off**.

NOTE: The unit can also be stopped via an external signal connected to the **Remote On/Off**.

General Configuration

Import and Export Unit Configuration

It is possible to configure a cooling unit by importing the settings of another cooling unit from a USB drive.

Export

1. Navigate to **Main > Configuration > Service > USB**.
2. Insert the USB drive into the USB port on the display.
3. Press **Export**.

The configuration of the unit will be exported to the USB drive.

A message stating "Abort export of data to USB drive" will disappear when exporting is complete.

4. Remove the USB drive from the USB port.

Import

1. Navigate to **Main > Configuration > Service > USB**.
2. Insert the USB drive into the USB port on the display.
3. Press **Import**.

The configuration of the unit will be downloaded from the USB drive.

4. Press **OK** when the "Import Complete" message appears.
5. Remove the USB drive from the USB port.

Cooling Unit Configuration

The cooling unit configuration options are set during the commissioning of the cooling units in the cooling group.

NOTE: Changing the settings incorrectly can cause malfunctions to your cooling unit. Only qualified service personnel should make changes to these settings.

NOTE: Displayed settings may vary based on model.

Configure the Unit

Operation Settings

Path: Main > On/Off

Settings in the **On/Off** menu control how the cooling unit will operate.

NOTE: Changing the settings incorrectly can cause malfunctions to your cooling unit. Only qualified service personnel should make changes to these settings.

NOTE: Displayed settings may vary based on model.

- **Unit:** Select whether the unit is **Off** or **On**.
- **Startup Delay:** Enter a value for the start-up in seconds. The startup delay begins when power is applied to the cooling unit. The cooling unit cannot begin operation until this delay expires. Use the startup delay to restart equipment sequentially in your room after a scheduled downtime or a power outage. (0–999 s)
- **Cooling Strategy:** Select the cooling strategy used to control the operation of the unit. (**RACS, HACS, INROW, CACS, Manual**)



See the [How the Modes of Operation Work](#), page 47 for more information on the types of cooling strategy.

- **Supply Air Setpoint:** The **Supply Air Setpoint** is the required temperature of the air expelled into the surrounding environment. (15.0–30.2°C (59.0–86.4°F))
 - NOTE:** The minimum setpoint (15°C (59°F)) is suggested when the load is close to the minimum load or when the outdoor air temperature is lower than 0°C (32°F).
- **Cool Setpoint:** Set the temperature that the cooling group should maintain in the IT space. (17.8–35.0°C (64.0–95.0°F))
- **Delta-T Setpoint:** When the group is programmed for HACS or RACS mode, this value specifies the desired temperature difference between the supply and return air temperatures when an AFC is not present. (**10F/5.6C, 15F/8.3C, 20F/11.1C, 25F/13.9C, 30F/16.7C, 35F/19.4C, 40F/22.2C**)
 - NOTE:** Set a lower **Cool Setpoint** or a smaller **Delta-T Setpoint** to assist with start-up during winter.
- **Maximum Fan Speed:** Set the maximum fan speed percentage allowed for the evaporator fans. (30.0–100.0% for one power supply, 30.0–130.0% for two power supplies)
- **Minimum Fan Speed:** Set the minimum fan speed percentage allowed for the evaporator fans.
 - NOTE:** The fan speed cannot exceed the **Maximum Fan Speed**.
 - NOTE:** 50% fan speed is suggested for most applications.

- **Manual IT Fan Speed:** Enter a fan speed percentage to manually control the fans in the unit. (20–130%)
 - NOTE:** The fan speed cannot exceed the **Maximum Fan Speed**.
- **Unit Role Override:** Determines the role of the cooling unit in the group.
 - **Automatic:** Allows the system to select the role of the cooling unit.
 - **Forced On:** Select **Forced On** if you have **Runtime Balancing Enable** selected and you DO NOT want a particular unit in the group to become a backup unit.
 - NOTE:** **Runtime Balancing Enable** can be changed on the **Main > Configuration > Group > Cooling** screen.
- **Idle on Leak Detect:** When set to **Yes**, the cooling unit will enter idle mode if a **Leak Detected Critical** alarm activates. Set to **No** to disable the cooling unit from entering idle mode if a leak is detected.
- **Shutdown Input State:** Displays the current state of the shutdown input.
- **Shutdown Input Present:** Select whether a shutdown input is present in the unit.
 - NOTE:** Same setting as on **Main > Configuration > Unit > Components**.
- **Shutdown Input Normal State:** Select the normal state of the shutdown input. (**Open, Closed**)
 - NOTE:** Same setting as on **Main > Configuration > Unit > Components**.
- **Protect On/Standby:** Select **Enable** to password protect the **Main > On/Off** menu.

Component Configuration

Path: Main > Configuration > Unit > Components

NOTE: Changing the settings incorrectly can cause malfunctions to your cooling unit. Only qualified service personnel should make changes to these settings. Displayed settings may vary based on model.

- **Voltage:** Displays the voltage of the unit. (**Not Configured, 100-120v, 200-240v**)
 - NOTE:** This is a read-only value.
- **Power Source:** Displays whether the **Primary** or **Secondary** power supply is the current input power source for the unit.
 - NOTE:** This is a read-only value.
- **Number of Evaporator Fan Power Supplies:** Set the number of fan power supplies installed in the electrical box. (1 or 2)
- **Condensate Pump Hold Time:** Set the length of time that the pump will continue to run after the lower condensate float switch is activated. (0–120 s)
- **Air Filter Type:** Select whether the air filters are **Standard** or **High Efficiency**.
- **Number of Rack Inlet Temp Sensors in Unit:** Set the number of rack inlet air temperature sensors connected to the unit. (0–4)
- **Number of Leak Detectors in Unit:** Set the number of leak sensors connected to the unit. (0–4)
- **Shutdown Input State:** Displays the current state of the shutdown input.
- **Shutdown Input Present:** Select whether a shutdown input is present in the unit.
- **Shutdown Input Normal State:** Select the normal state of the shutdown input. (**Open, Closed**)

Cooling Group Configuration

The cooling group configuration settings determine which components are available and how the cooling group should operate.

NOTE: Changing the settings incorrectly can cause malfunctions to your cooling unit. Only qualified service personnel should make changes to these settings.

NOTE: Displayed settings may vary based on model.

Configure the Cooling Group

Path: Main > Configuration > Group > Composition

The **Composition** menu contains settings that identify the number of cooling units installed in this cooling group and the physical arrangement of those cooling units.

- **Number of Units in Group:** The number of cooling units in this cooling group. Up to 20 cooling units can be joined together to work as a single cooling group.
- **Number of AFC Controllers:** The number of AFC units in the group (0–5).
- **Number of Backup Units:** The total number of desired backup cooling units. This value can range from zero to one less than **Number of Units in Group**.
- **Altitude:** The distance of the unit above sea level in meters or feet depending on the user preferences. The altitude is used to calculate the pressure compensation if an AFC is installed. The altitude is also used in conversions between absolute (g/Kg) and relative (%RH) humidity.

Configure Modbus

Use the **Modbus TCP** menu to set up communications between the cooling unit and the building management system. Select to enable TCP communication protocol.

Path: Main > Configuration > Modbus > Serial

- **Enable Serial Modbus:** Select to enable Modbus serial communication protocol.
- **Address:** Each Modbus device must have a unique target identification number. Enter a unique number for this cooling unit. (1–247)
- **Baud Rate:** Set to either 9600 bps or 19200 bps.
- **Parity:** Select **Even**, **Odd**, or **None**.

NOTE: If you select **Even** or **Odd** parity, then select 1 stop bit on the host computer. If you select **None**, then select two stop bits on the host computer.

Path: Main > Configuration > Modbus > TCP

- **Enable Modbus TCP:** Select to enable Modbus TCP.
- **Port:** Enter a port. The default port is 502. For additional security enter a port between 5000 and 32768 (TCP connection only).
- **Restore Port to Default:** Press to restore the **Port** to default settings (502).

Interface Connection

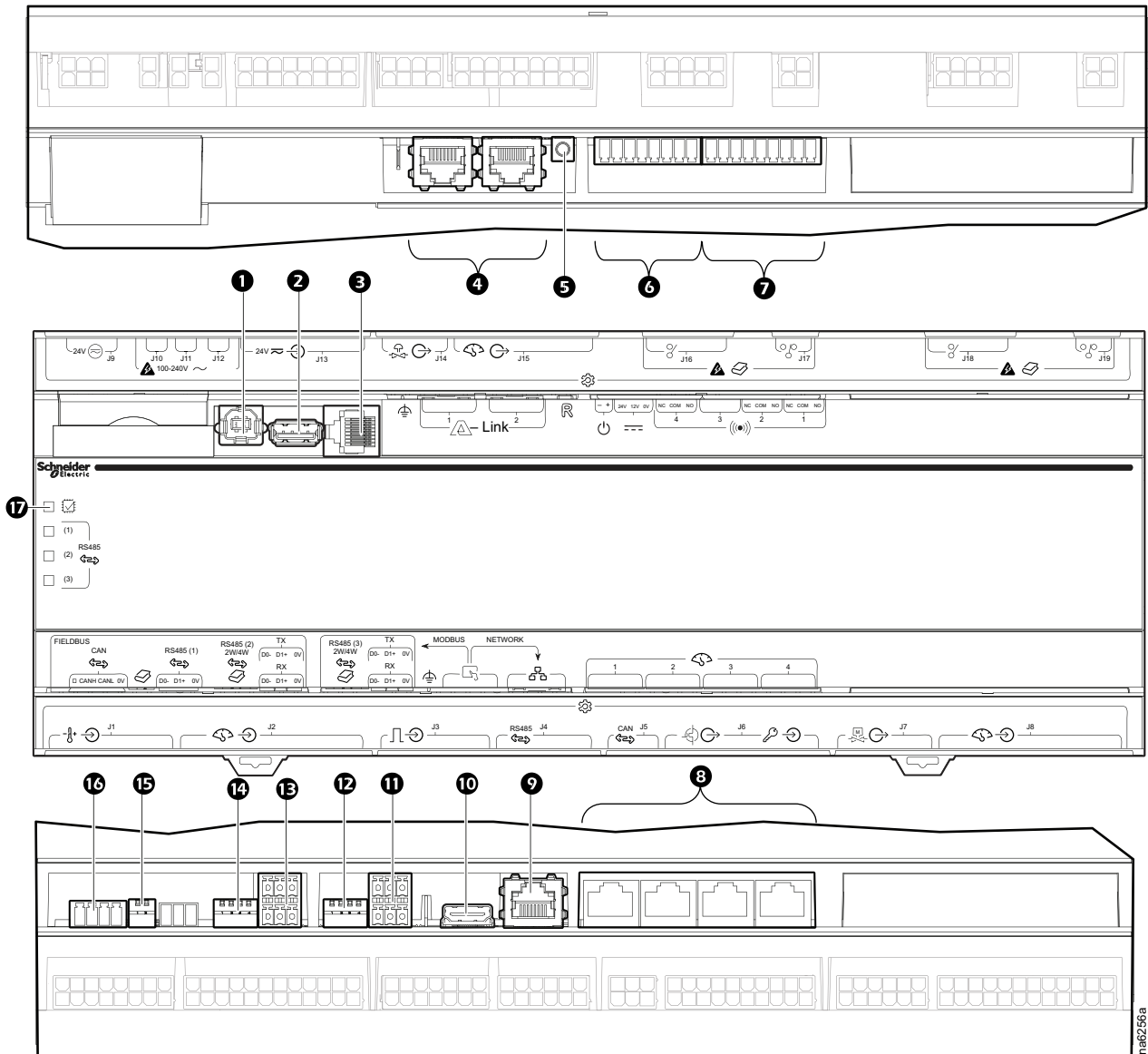

na8256a

Item	Description	Item	Description
1	USB device port	10	Touch screen display connection
2	USB host port (Not available)	11	Modbus connection
3	Serial port (Not available)	12	Modbus configuration switches
4	A-Link ports	13	Fieldbus Modbus connection (Not available)
5	Reset button	14	Fieldbus Modbus configuration switches (Not available)
6	Output relay 4/standby input	15	Fieldbus CANbus configuration switches
7	Output relay 1-3	16	Fieldbus CANbus connection
8	Universal sensor ports	17	Processor status LED
9	Network connection		

A-Link Connections

NOTE: All input and output connections should be wired as Class 2 circuits.

The A-Link bus connection allows a maximum group of twenty (20) Uniflair InRow ACRD30X units to communicate with each other.

To enable the units to function as a group, link them together using a standard pin-out CAT-5 cable with RJ-45 connectors. The A-Link bus must be terminated at the first and last unit installed in the group. An A-Link terminator is supplied with each unit.

NOTICE

CAT 5 PINOUT

Devices connected on the A-Link ports should use a standard pin-out (1-1, 2-2, 3-3, 4-4, 5-5, 6-6, 7-7, 8-8) CAT5 cable only.

Failure to follow these instructions can result in equipment damage.

NOTE: The maximum wire length for the entire group must not exceed 500 m (1640 ft).

Active Flow Controllers (AFC)

If AFC units are installed in the cooling group in a HACS or CACS environment, they are connected to the A-Link bus as shown. If the cooling group is in an under floor environment, the AFC unit is connected through the J5 port on the controller.



See the *AFC Installation Manual* for more information.

Control the Environment

The primary function of the cooling unit is to cool air from the hot aisle and deliver it to the cold aisle at the temperature setpoint. The control strategies employed by the cooling unit depend upon the deployment strategy of the cooling group.

In an InRow environment, the cooling unit supplies constant-temperature supply air to the common cold aisle. The fan speed is modulated to ensure that the desired volume of air reaches the IT equipment. The fan speed is determined by the difference between the cooling setpoint and the maximum rack air inlet temperature.

In a HACS or RACS environment, the cooling unit neutralizes the heat accumulated in the common hot aisle and expels it back into the surrounding environmental space while maintaining the desired temperature in the cold aisle.

In a CACS environment, the cooling unit supplies constant temperature supply air to the enclosed cold aisle. The fan speed is modulated to ensure that the required volume of air reaches the IT equipment.

How the Modes of Operation Work

Path: Main > Configuration > Group > Cooling

Path: Main > On/Off

NOTE: The **Cooling Strategy** settings in both menus are the same settings.

The cooling control varies based on the **Cooling Strategy** setting.

- **Cooling Strategy:** The cooling unit uses a direct-expansion coil and a variable-speed compressor to modulate refrigerant flow through the coil, and a set of fans to control airflow through the coil. The cooling output is determined by the difference between the supply setpoint and the supply air temperature of the cooling unit.
 - **INROW:** The fan speed is controlled by comparing the rack inlet temperature to the cooling setpoint. As the rack temperature increases compared to the cooling setpoint the fans increase output to maintain the setpoint. As rack inlet temperature decreases compared to the cooling setpoint the fans decrease output to maintain the setpoint.
 - **RACS/HACS:** When Active Flow Controller (AFC) devices are present, the controller utilizes differential pressure data supplied by the AFC(s) to supply the correct amount of airflow to the IT load. When AFC devices are not present, the fan speed is controlled by the fan speed preference setting. The fan speed selection is based on the temperature differential detected across the cooling unit. As return temperatures deviate from the fan speed preference setting, the fan speed increases to bring the temperature difference back down to the setpoint or the fan output is reduced to increase the unit temperature differential. By maintaining the desired temperature differential, the system matches the airflow requirements of the load.
 - **CACS:** When AFC devices are present, the controller utilizes differential pressure data supplied by the AFC(s) to supply the correct amount of airflow to the IT load. When AFC devices are not present, the evaporator fan speed is controlled by comparing the rack inlet temperature to the cooling setpoint. As the rack temperature increases compared to the cooling setpoint, the fans output is increased to maintain the setpoint. As rack temperature decreases compared to the cooling setpoint the fans output is decreased to maintain the setpoint.
 - **Manual:** The fan speed is controlled by the user-input value for **Manual IT Fan Speed**.

The cooling unit is equipped with compressor cycling control that allows for minimizing the number of compressor on and off cycles. The compressor will cycle off when the supply air temperature drops below 13°C (55.4°F) whether or not the compressor minimum on-time of three minutes has elapsed. Once off, the

compressor will not normally cycle on until the supply temperature reaches its setpoint and the minimum off-time of two minutes has elapsed. However, the compressor will cycle on disregarding the off-time if it is a standalone unit or if the unit is power cycled, the compressor will cycle on regardless of whether or not the minimum off time has elapsed (InRow and CACS only).

Compressor cycles are monitored over a seven-day period. If over said period the number of cycle is more than 12 per hour on average, the **Excessive Compressor Cycling** alarm is set.

Setpoints

A setpoint is the target value that a cooling group tries to maintain in the environment. The default setpoints are appropriate for most cooling applications.

NOTE: Changing the settings incorrectly can cause malfunctions to your cooling unit. Only qualified service personnel should make changes to these settings.

NOTE: Displayed settings may vary based on model and unit configuration.

Path: Main > Configuration > Group > Cooling

- **Cooling Strategy:** Select the cooling strategy used to control the operation of the unit. (**RACS, HACS, INROW, CACS, Manual**)



See the [How the Modes of Operation Work](#), page 47 for more information on the types of cooling strategy.

- **Supply Air Setpoint:** The **Supply Air Setpoint** is the required temperature of the air expelled into the surrounding environment. (15.0–30.2°C (59.0–86.4°F))
 - NOTE:** The **Supply Air Setpoint** is defined by Schneider Electric qualified personnel when the cooling group is commissioned.
- **Cool Setpoint:** Set the temperature that the cooling group should maintain in the IT space. (17.8–35.0°C (64.0–95.0°F))
- **Delta-T Setpoint:** When the group is programmed for HACS or RACS mode, this value specifies the desired temperature difference between the supply and return air temperatures when an AFC is not present. (**10F/5.6C, 15F/8.3C, 20F/11.1C, 25F/13.9C, 30F/16.7C, 35F/19.4C, 40F/22.2C**)
 - NOTE:** Set a lower **Cool Setpoint** or a smaller **Delta-T Setpoint** to assist with start-up during winter.
- **Load Assist Enable:** When set to **Enable**, provides extra capacity via a backup cooling unit in the event that a primary unit is unable to service the demand. When the assistance is no longer needed, the unit will return to the backup state.
 - NOTE:** Redundancy (backup units), runtime balancing, and load assist modes are only supported in HACS, RACS, and CACS configurations.
- **Runtime Balancing Enable:** When set to **Enable**, the system maintains similar run times between units in the group. When the difference between the runtime hours of the cooling units in the system exceeds the value entered for **Runtime Balancing Difference**, the system will automatically exchange modes between the longest running primary unit and the backup unit with equal or greater capability if available with the least runtime hours.
 - NOTE:** Runtime hours are hours that the cooling unit is actually operating for consecutive hours of time.
- **Runtime Balancing Difference:** Enter the number of hours used to maintain runtime balancing in the cooling group. (24–720 hours)
- **Switchover Handoff Time:** Enter the length of time that the currently active unit will remain on after another unit is made the active unit. Both units will be running during this time. (0–30 minutes)

- **Humidification Setpoint:** The target value for the relative humidity of conditioned air, as a percentage. The **Humidification Setpoint** must be at least 5% RH below the **Dehumidification Setpoint**. (0-100%)
NOTE: Available for ACRD301P and ACRD301H units only.
- **Dehumidification Setpoint:** The target value for the relative humidity of conditioned air, as a percentage. The **Humidification Setpoint** must be at least 5% RH below the **Dehumidification Setpoint**. (0-100%)
NOTE: Available for ACRD301P units only.
- **Humidity Hysteresis:** Enter the hysteresis value for humidity, which is the humidity percentage below the setpoint at which humidification is permitted. (0-20%)
NOTE: Available for ACRD301P and ACRD301H units only.
- **Reheat Setpoint:** The target value for air leaving the cooling unit. This setting must be at least 2°F (1.1°C) below the **Supply Air Setpoint**. (10–15°C (50–59°F))
NOTE: Available for ACRD301P and ACRD301R units only.

Active Flow Controller (AFC) Settings

Path: Main > Configuration > Containment Systems

- **Number of Active Flow Controllers:** Set the number of Active Flow Controller units in the group. (0–5)
- **Active Flow Control Lamp Test:** When set to **On**, the Active Flow Controller (s) LEDs will cycle through a red, green, and blue illumination pattern.
- **Active Flow Control Bias:** This setting is used to change the bias of the controller by adjusting the contained aisle pressure threshold. **Zero** is the default setting. Only qualified service personnel can make changes to these settings.
 - Hot Aisle Containment (HACS)
 - If the cooling units seem to be under-cooling, select **Negative** or **Slightly Negative** to adjust the aisle pressure for additional cooling.
 - If the cooling units seem to be over-cooling, select **Positive** or **Slightly Positive** to adjust the aisle pressure for less cooling.
 - Cold Aisle Containment (CACS)
 - If the cooling units seem to be under-cooling, select **Positive** or **Slightly Positive** to adjust the aisle pressure for additional cooling.
 - If the cooling units seem to be over-cooling, select **Negative** or **Slightly Negative** to adjust the aisle pressure for less cooling.

Setting	Blue LED—HACS Red LED—CACS	Setpoint Green LED	Red LED—HACS Blue LED—CACS
Positive	< -0.008 in. ±3%	0.004 ±0.0004 in.	> 0.016 in. ±3%
Slightly Positive	< -0.010 in. ±3%	0.002 ±0.0004 in.	> 0.014 in. ±3%
Zero	< -0.012 in. ±3%	0.000 ±0.0004 in.	> 0.012 in. ±3%
Slightly Negative	< -0.014 in. ±3%	-0.002 ±0.0004 in.	> 0.010 in. ±3%
Negative	< -0.016 in. ±3%	-0.004 ±0.0004 in.	> 0.008 in. ±3%

Envelope Management

Envelope management is used to control the acceptable operating range for compressors.

Variable-Speed Compressor Operating Range

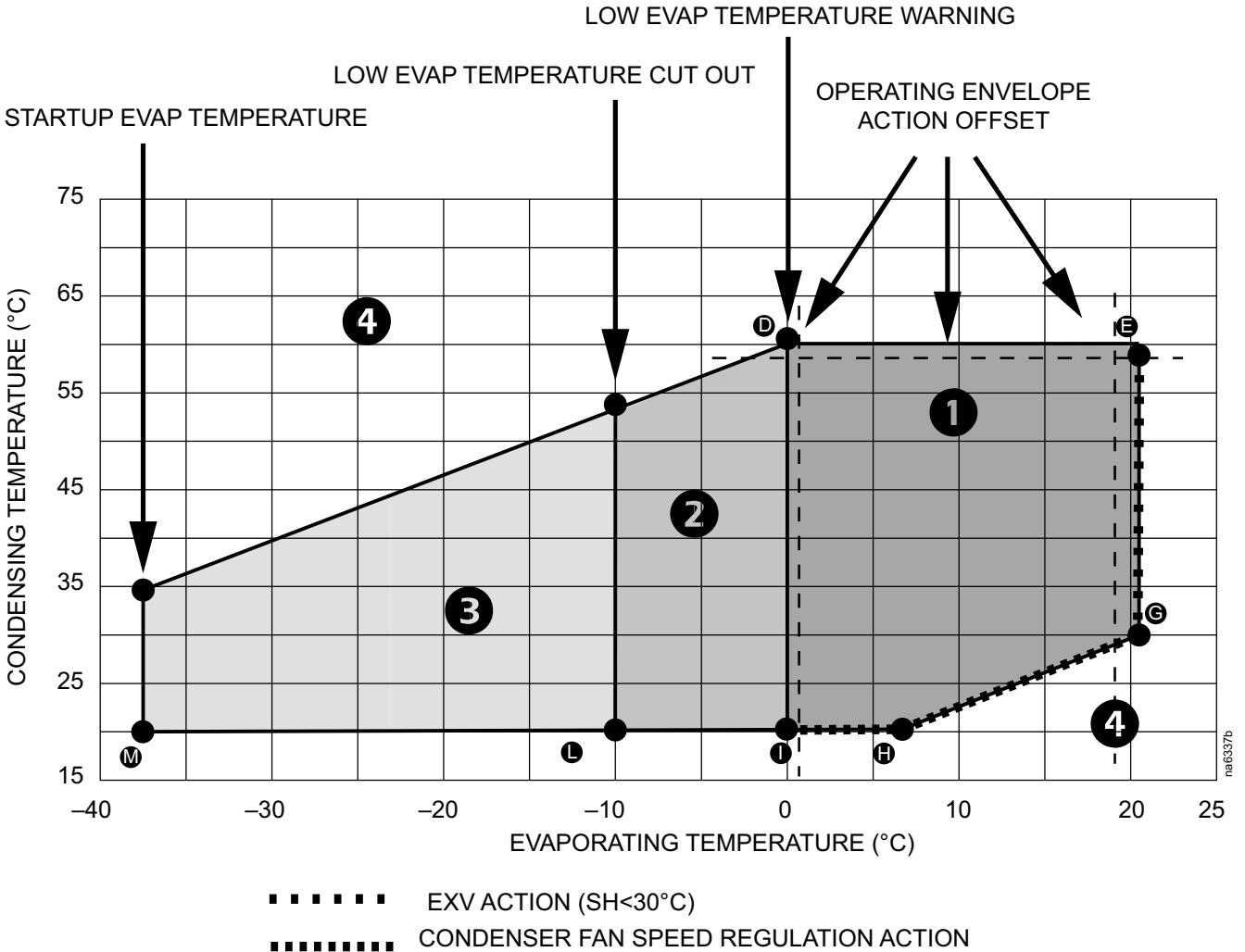

NOTE: The operating envelope for your unit will differ based on unit settings and compressor model; this example is based on default values for the VZH044CG compressor model.

Data Point	Condensing Pressure – barg	Evaporating Pressure – barg	Data Point	Condensing Pressure – barg	Evaporating Pressure – barg
D	36.95	11.56	I	13.45	6.97
E	17.86	11.56	L	13.45	4.71
H	13.45	8.33	M	13.45	1.00

Zone	Description	Zone	Description
1	Open operating area	3	Compressor can operate in this region for a maximum of 240 seconds at start-up
2	Compressor can operate in this region for a maximum of 240 seconds at any time during the compressor run cycle	4	Not acceptable operating range

The compressor will be allowed to start if the evaporation temperature exceeds the **Startup Evap Temperature** value. The compressor can operate in zone 3 for a maximum of 240 seconds only after startup. After the evaporation temperature enters zone 2, the compressor can operate in this zone for a maximum of 240

seconds. After the evaporation temperature enters zone 1, it can return to zone 2 for a maximum of 240 seconds. If the evaporation temperature drops below the **Low Evap Temperature Cut Out** value at any time after entering zone 2, it will turn off the compressor. The compressor can run in zone 1 indefinitely. The compressor will not operate in zone 4.

The controller continually adjusts the condensing temperature setpoint such that it follows the dashed line between **1**, **H**, and **G**. This causes the condenser fan to drive the condensing temperature as low as possible thus reducing the load on the compressor.

If the evaporating temperatures near the limits of the operating envelope, the controller will take actions to keep the compressor operating within the accepted ranges.

- If the evaporating temperature reaches a temperature within **Op. Env. Action Offset** degrees of the operating envelope boundaries formed by points **E** and **G**, the controller will adjust the electronic expansion valve (EXV) to keep the evaporating temperature within the acceptable range.
- If the evaporating temperature reaches a temperature within **Op. Env. Action Offset** degrees of the operating envelope boundary formed by points **D** and **1**, the controller will adjust the compressor speed to keep the evaporating temperature within the acceptable range.
- If the condensing temperature reaches a temperature within **Op. Env. Action Offset** degrees of the operating envelope boundary formed by points **D** and **E**, the controller will adjust the compressor speed to keep the condensing temperature within the acceptable range.



See Compressor Settings, page 131.

Run Hours and Service Intervals

Run Hours

The cooling unit records the number of hours select components have been in operation. When a component is replaced, use the **Run Hours Reset** menu to reset the run hours for the displayed component to zero. These settings are read-only values.

Path: Main > Status > Hours

- **Unit Run Hrs**
- **Air Filter Run Hrs**
- **Condenser Fan Run Hrs**
- **Condensate Pump Run Hrs**
- **Fan 1 Run Hrs**
- **Fan 2 Run Hrs**
- **Fan 3 Run Hrs**
- **Fan 4 Run Hrs**
- **Fan 5 Run Hrs**
- **Fan 6 Run Hrs**
- **Fan 7 Run Hrs**
- **Fan 8 Run Hrs**
- **Humidifier Run Hours**
- **Heater 1 Run Hours**
- **Heater 2 Run Hours**

NOTE: Fan 1 is the bottom fan; fan 8 is the top fan.

Reset Run Hours

Path: Main > Configuration > Service > Run Hours Reset

Settings under this menu are used to reset the run hour alarms that are configured as reminders for regular maintenance inspection.

Select **Reset** and press **OK** to reset the run hours for an individual component. The following components can have run hour alarms reset:

- Unit Alarm Reset
- Compressor Alarm Reset
- Air Filter Alarm Reset

Service Intervals

Path: Main > Configuration > Unit > Alarms > Maintenance

Each component interval setting has an alarm. If set to **Enable**, the annunciator will sound when the service interval for the component has elapsed. The alarms are cleared by selecting the check box for the **XXX Alarm Reset** for each component to reset the service alarm and pressing **OK**. Enable service interval alarms and set the number of weeks to service the following components:

- **Unit Run Hours:** Displays the total hours the unit has been in operation.
- **Unit Alarm Enabled:** Select to **Enable** or **Disable** the alarm.
- **Unit Alarm Interval:** Set the interval for the service alarm for the cooling unit. (1–300 wk)

- **Air Filter Run Hrs:** Displays the number of hours the filters have been in use.
- **Air Filter Alarm Enabled:** Select to **Enable** or **Disable** the alarm.
- **Air Filter Alarm Interval:** Set the interval for the service alarm for the air filters. (1–300 wk)

User Security Settings

The **Security** menus under the **Display** menu include options for user access to the unit.

Add a New User or Edit an Existing User

Path: Main > Configuration > Display > Security

1. Select **Add User** to add a new user or select **Edit User** to edit an existing user of the system.
2. In the **Name** field, enter the name of the user.
3. In the **Pin** field, enter a pin code for the user.
4. In the **Confirm Pin** field, re-enter the pin code of the user.
5. Press **OK** to save your settings.

Delete a User

Path: Main > Configuration > Display > Security > Delete User

1. Browse to the user that you wish to delete using the up and down arrows and press **OK**.
2. Press **Yes** to confirm deletion of an existing user of the system.

Display Settings

The **Display** menus set the display interface settings, including time and date, units, passwords, and time-out. You can also adjust the contrast and sound settings.

Language, Date, Time, and Temperature

Path: Main > Configuration > Display > Preferences

- **Language:** Select the correct language for the display.
- **Date Format:** Select the display format for the date.
- **Temperature:** Select **Metric** or **US Customary** for temperature format.
- **Manual:** Manually enter the current and time instead of retrieving from a server.
 - **Current Date:** Enter the day, month, and year. The date is displayed on some status screens and is also used in the alarm/event log to date-stamp events.
 - **Current Time:** Enter the current time for the display.
- **Synchronize with NTP Server:** Select to sync the time and date with the Network Time Protocol server.

Screen Visibility and Audible Tones

Path: Main > Configuration > Display > System Settings

- **Alarm Volume:** Select the level of audio at which alarms will sound (**Off**, **Low**, **Medium**, or **High**).
- **Button Volume:** Select the volume at which a tone will be produced every time a button is pressed on the display interface. The audible tone can also be set to **Off**.
- **Brightness:** Controls the visibility of the display.
- **Enable Backlight Timeout:** **Enable** or **Disable** backlight timeout settings.
- **Backlight Timeout:** Adjust the backlight timeout settings.
 - **Minutes:** Turns off unit backlight after a specified amount of time. Timeout range is 1–60 minutes.
 - **Intensity:** Select the visibility of the display during backlight timeout.
 - **Off:** The display will remain at the normal intensity level.
 - **Very Low:** The display will be very dim.
 - **Low:** The display will be dim.
 - **Medium:** The display will dim to about half of the normal brightness.
- **Auto Logoff:** Automatically signs current user out of the system after specified amount of time. Options are 1, 5, 10, 30, or 60 minutes.

Restore Defaults

Path: Main > Configuration > Restore Defaults

The **Restore Defaults** screen is used to restart the display and reset display settings to factory defaults.

NOTE: The controller settings will not be restored.

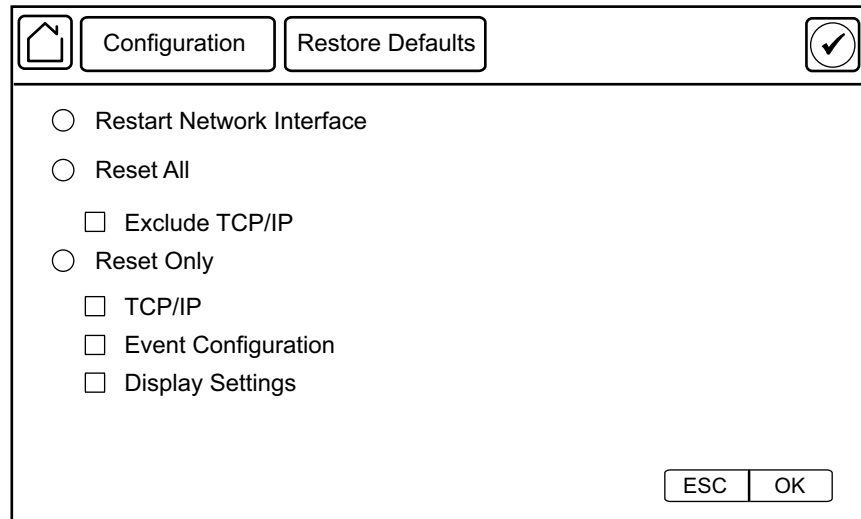

Network Configuration

The cooling unit is shipped with a Network Management Card (NMC) that enables you to manage the cooling unit over your network. Configure the network settings for the cooling unit Network Management Card from the display interface. The management card allows remote control and configuration of the equipment.

Configure the Network

TCP/IPv4 Settings

Path: Main > Configuration > Network > TCP/IPv4

Enable IPv4 (if applicable), and select the **Address Mode (Manual, DHCP, BOOTP)**.

- **Manual:** Enter the IP Address, subnet mask, and default gateway.
- **BootP:** Set the Network Management Card of the cooling unit to obtain its network settings from a BootP server.
- **DHCP:** Set the Network Management Card of the cooling unit to obtain its network settings from a DHCP server. Select whether or not to require vendor-specific cookies to accept the DHCP address.

TCP/IPv6 Settings

Path: Main > Configuration > Network > TCP/IPv6

Enable IPv6 (if applicable).

- Select **Auto Configuration** or **Manual Configuration**, and select the **DHCPv6 Mode (Router Controlled, Non-Address Information Only, Address and Other Information, or Never)**.
- For **Manual Configuration**, enter the **System IP** and **Default Gateway**.

Web Access Settings

Path: Main > Configuration > Network > Web Access

Enable Web (if applicable) and select the **Access Mode (HTTP or HTTPS)** and enter the **Port**.

FTP Server Settings

Path: Main > Configuration > Network > FTP Server

Enable FTP (if applicable) and enter the **Port**.

View Status Readings

The display interface has several options for viewing the status of the cooling unit, the cooling group to which the cooling unit belongs, and the environment being controlled. The status readings for the cooling unit are available under the **Status > Unit** screen, and status readings for the cooling group are available under the **Status > Group Status** screen or on the overview screen.

Overview Screen

After start-up, the display shows an overview screen containing basic status information. Press **Home** to toggle between the main menu and overview screen. After a period of inactivity, the display also reverts back to the overview screen.

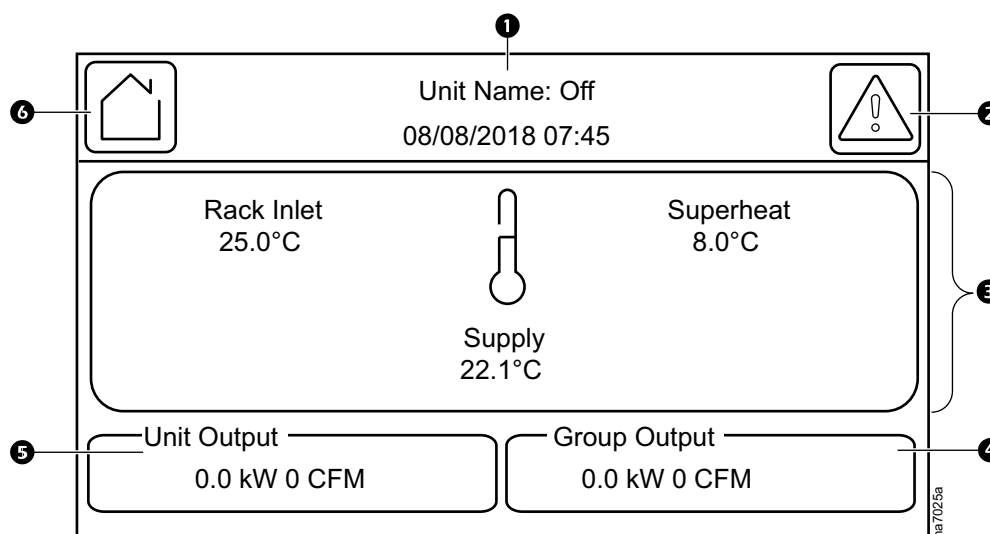

Item	Description
1	Unit operational status and current date and time
2	Alarms button
3	<ul style="list-style-type: none"> • Rack Inlet: The average reading from rack inlet temperature sensors connected to this unit. This is displayed when the Cooling Strategy is set to INROW, CACS, or Manual. • Return Temp: The return air temperature reading. This is displayed when the Cooling Strategy is set to HACS or RACS. • Superheat: The superheat reading for this unit: the temperature difference between refrigerant entering and leaving the coil. • Supply: The average temperature from the top and bottom supply air temperature sensors connected to this unit.
4	The total cooling output and airflow of all units in the cooling group.
5	The cooling output and airflow of this unit.
6	Home button

Cooling Unit Status

Path: Main > Status > Unit

View information specific to this cooling unit.

NOTE: These are read-only values.

- **Mode:** Displays the current operational mode of the unit.
 - **Unknown:** A status cannot be currently acquired.
 - **Init:** Unit is currently initializing.
 - **Off:** Unit is currently off.
 - **Standby:** Unit is in standby mode.
 - **Delaying:** Unit is delaying start until the **Startup Delay** time has elapsed.
 - **Active:** Unit is currently cooling.
- **Supply (Average) Temperature:** The average temperature from the top and bottom supply air temperature sensors connected to this unit. (°C (°F))
- **Rack (Average) Temperature:** The average reading from rack inlet temperature sensors connected to this unit. (°C (°F))
- **Return (Average) Temperature:** The average temperature from the top and bottom return air temperature sensors connected to this unit. (°C (°F))
- **Humidity:** The current relative humidity of the IT room. (%RH)
- **Airflow:** The current airflow output of the unit. (l/s (ft³/m))
- **Air Filter Pressure:** The current air pressure at the air filter. (Pa (in. WC))
- **Cool Demand:** The cooling output required to meet the current heat load of the conditioned space. (kW)
- **Cool Output:** The combined output of the cooling unit. (kW)

Cooling Group Status

Path: Main > Status > Group Status

View information specific to this cooling group.

NOTE: These are read-only values.

- **Group Minimum Rack Temperature:** The lowest rack temperature reported by any cooling unit in the cooling group. (°C (°F))
- **Group Maximum Rack Temperature:** The highest rack temperature reported by any cooling unit in the cooling group. (°C (°F))
- **Group Dew Point Temperature:** The average group dew point temperature. (°C (°F))
- **Total Airflow:** The combined airflow output of the cooling units in the cooling group. (l/s (ft³/m))
- **Total Air Side Cooling Demand:** The cooling output required to meet the current heat load of the conditioned space. (kW)
- **Total Sensible Cooling Power:** The combined output of the cooling group. (kW)
- **Active Flow Control Status:** The conditional state of the containment air pressure differential measurement device (AFC).
 - **Under:** The air flow status on at least one AFC unit is insufficient. The LED on the AFC will be illuminated as red.
 - **OK:** There is nominal air flow status on all AFC units. The LED on the AFC will be illuminated as green.
 - **Over:** There is a surplus of air flow status on at least one AFC unit. The LED on the AFC will be illuminated as blue.
 - **NA:** There are no AFC units installed or no status reading is available.



See Active Flow Controller (AFC) Settings, page 50 for information on adjusting the **Active Flow Control Bias**.

Sensor Readings

Path: Main > Status > Details > Environment

The **Environment** menu provides the readings from sensors connected to the unit.

- **Upper Supply Temperature:** The temperature from the top supply air temperature sensor connected to this unit. (°C (°F))
- **Lower Supply Temperature:** The temperature from the bottom supply air temperature sensor connected to this unit. (°C (°F))
- **Upper Return Temperature:** The temperature from the top return air temperature sensor connected to this unit. (°C (°F))
- **Lower Return Temperature:** The temperature from the bottom return air temperature sensor connected to this unit. (°C (°F))
- **Room Temperature:** The temperature of the ambient air in the IT space. (°C (°F))
- **Humidity:** The relative humidity of the air in the IT space. (%RH)
- **Dew Point Temperature:** The dew point of the IT space. (°C (°F))
- **Rack Inlet Temperature 1:** The temperature from the rack inlet 1 air temperature sensor connected to this unit. (°C (°F))
- **Rack Inlet Temperature 2:** The temperature from the rack inlet 2 air temperature sensor connected to this unit. (°C (°F))

- **Rack Inlet Temperature 3:** The temperature from the rack inlet 3 air temperature sensor connected to this unit. (°C (°F))
- **Rack Inlet Temperature 4:** The temperature from the rack inlet 4 air temperature sensor connected to this unit. (°C (°F))

Refrigerant System

Path: Main > Status > Details > DX

The **DX** menu provides information for the refrigerant system components and pressure and temperature readings.

NOTE: These are read-only values.

- **Suction Pressure:** The pressure of the refrigerant at the suction line. (bar (psi))
- **Discharge Pressure:** The pressure of the refrigerant at the discharge line. (bar (psi))
- **Suction Evap. Temp.:** The temperature of the refrigerant at the suction line. (°C (°F))
- **Discharge Cond. Temp.:** The temperature of the refrigerant at the discharge line. (°C (°F))
- **Outlet Evap Coil Temperature:** The temperature of the refrigerant leaving the evaporative coil. (°C (°F))
- **Inlet Evap Coil Temperature:** The temperature of the refrigerant entering the evaporative coil. (°C (°F))
- **Superheat:** The temperature difference required to keep the refrigerant in a gaseous state. ($\Delta^{\circ}\text{C}$ ($\Delta^{\circ}\text{F}$))
- **Avg Fan Speed:** The current average speed of the eight fans in the unit. (%)
- **Compressor Speed:** The current speed of the compressor. (Hz)
- **EEV Position:** The current open percentage of the electronic expansion valve. (%)

Power Information

Path: Main > Status > Details > Power

The **Power** menu provides power consumption information for components in the unit.

NOTE: These are read-only values.

- **Power Feed Type:** Displays whether the indoor unit has a **Single** or **Dual** power feed.
- **Active Power Source:** Displays if the unit is using the primary or secondary power source.
- **Primary Power Source:** If the power source is **Bad**, then the ATS will transfer to the secondary power supply.
- **Secondary Power Source:** If the secondary power source is good, then it can be used in the event of primary source is bad.
- **Fan Power Supply 1:** The current draw of fan power supply 1. (A)
- **Fan Power Supply 2:** The current draw of fan power supply 2. (A)
- **Compressor Power:** The current draw of the compressor. (kW)

Input/Output States

Path: Main > Status > Details > Input/Output

The **Input/Output** menu provides the current state of input/output connections.

NOTE: These are read-only values.

- **Standby Input State:** The current state of the shutdown input. (**Open** or **Closed**)
- **Alarm Relay 1:** The current state of alarm relay 1. (**Open** or **Closed**)
- **Alarm Relay 2:** The current state of alarm relay 2. (**Open** or **Closed**)
- **Alarm Relay 3:** The current state of alarm relay 3. (**Open** or **Closed**)
- **Alarm Relay 4:** The current state of alarm relay 4. (**Open** or **Closed**)

About the Network

View identifying information about the cooling network parameters (IPv4 or IPv6).

Path: Main > About > Network

IPv4 Configuration: If IPv4 is used, this section will display IPv4 information.

- **Enabled:** Identifies whether the specified network is enabled or not.
- **Mode:** Identifies how the IP address is obtained.
- **IP Address:** The IP address of the unit.
- **Subnet Mask:** The subnet mask for the sub-network.
- **Default Gateway:** The default gateway address used by the network.

IPv6 Configuration: If IPv6 is used, this section will display IPv6 information.

Press **Addresses** to view all assigned IPv6 addresses.

- **Enabled:** Identifies whether the specified network is enabled or not.
- **Auto Configuration:** Displays **Yes** if the IP address is assigned automatically.
- **Manual Configuration:** Displays **Yes** if the IP address is assigned manually.
- **DHCPv6 Mode:** The DHCPv6 mode.
 - **Router Controlled:** DHCPv6 is controlled by the **M** (Managed Address Configuration Flag) and **O** (Other Stateful Configuration Flag) flags received in IPv6 Router Advertisements. When a router advertisement is received, the network management card (NMC) checks whether the **M** and **O** flags are set. The NMC interprets the state of the **M** and **O** “bits” for the following cases:
 - Neither is set: Indicates local network has no DHCPv6 infrastructure. The NMC uses Router Advertisements and/or manual configuration to get non-link-local addresses and other settings.
 - **M**, or **M** and **O** are set: In this situation, full DHCPv6 address configuration occurs. DHCPv6 is used to obtain addresses AND other configuration settings. This is known as DHCPv6 stateful. Once the **M** flag has been received, the DHCPv6 address configuration stays in effect until the interface in question has been closed, even if subsequent Router Advertisement packets are received in which the **M** flag is not set. If an **O** flag is received first, then an **M** flag is received subsequently, the NMC performs full address configuration upon receipt of the **M** flag.
 - Only **O** is set: In this situation, the NMC sends a DHCPv6 Info-Request packet. DHCPv6 is used to configure “other” settings (such as location of DNS servers), but NOT to provide addresses. This is known as DHCPv6 stateless.
 - **Address and Other Information:** DHCPv6 is used to obtain addresses AND other configuration settings. This is known as DHCPv6 stateful.
 - **Non-Address and Information Only:** DHCPv6 is used to configure “other” settings (such as locations of DNS servers), but NOT to provide addresses. This is known as DHCPv6 stateless.
 - **Never:** If this radio box is selected, DHCPv6 is NOT to be used for any configuration settings.

About the Unit

View identifying information that is helpful when obtaining service.

NOTE: Displayed settings are read-only and will vary based on unit type and configuration.

Path: Main > About > Unit

- **Model Number:** The model number of the unit.
- **Serial Number:** The serial number of the unit.
- **Firmware Revision:** The firmware revision of the unit.
- **Development Firmware Revision:** The developmental firmware revision of the unit.
- **Hardware Revision:** The hardware revision of the unit.
- **Manufacture Date:** The date the cooling unit was manufactured.
- **PIC1 Firmware Revision:** The firmware revision of the PIC1 processor.
- **PIC2 Firmware Revision:** The firmware revision of the PIC2 processor.

About the AFC

Path: Main > About > AFC

View information about the Active Flow Controller units in the cooling group.

- **Serial Number:** The serial number of the AFC.
- **Firmware Revision:** The firmware revision of the AFC.
- **Hardware Revision:** The hardware revision of the AFC.
- **Model Number:** The model number of the AFC.
- **Lamp Test Enable:** Select the check box and press **OK** to test the LED on the AFC. The LED will cycle through a red, green, blue illumination pattern until the user stops the test. To stop the LED test, deselect the check box and press **OK**.

About the Display

Path: Main > About > Display > Device

Device summary: Information about the physical display device.

- **Model Number:** The model number of the display interface.
- **Serial Number:** The serial number of the display interface.
- **Hardware Revision:** The hardware revision of the display interface.
- **Manufacture Date:** The date the display interface was manufactured.
- **MAC Address:** The MAC address of the unit.

Path: Main > About > Display > Firmware

Firmware summary: View identifying revision information about the display interface firmware:

- Application
- APC OS (AOS)
- APC Boot Monitor
- Video Driver
- FPGA

Logs

Event Log

The **Event Log** saves status information and a message each time a change in the unit is detected. Alarms and events are recorded in the log and displayed on the **Active Alarms** screen. Status events (informational) and system configuration changes are only displayed in the event log.

The screenshot shows the 'Event Log' screen with a table of events and a navigation bar at the bottom. The table has columns for 'Date/Time' and 'Event'. The events listed are:

Date/Time	Event
09/20/2016 15:56:21	Data Log cleared
09/20/2016 15:56:21	Configuration change. Data log size.
09/20/2016 15:53:32	Web user 'apc' logged in from XX.XXX.XXX.XXX.
09/20/2016 15:47:34	FTP user 'apc' logged in from XX.XXX.XXX.XXX.
09/20/2016 15:32:38	FTP user 'apc' logged in from XX.XXX.XXX.XXX.

The navigation bar at the bottom includes icons for: CLEAR LOG (trash), FIRST (left arrow), BACK (left arrow), CURRENT PAGE/TOTAL PAGES (1 / 80), FORWARD (right arrow), LAST (right arrow), and FILTER LOG (funnel). Labels with arrows point to these icons from below the screen.

View Event Log

Path: Main > Logs > Event Log

The **Event Log** keeps a record of all alarms and events. The screen displays the following:

- The name of the event.
- The severity of the event.
- The time and date the event occurred.

Use the arrows to scroll through the list of events and display the date and time for each event.

Filter Event Log

Events in the **Event Log** can be sorted by time or severity. Events can also be displayed by **Device Events** or **System Events**. Press **ESC** to return to the previous screen without making changes; press **OK** to accept changes.

The screenshot shows the 'Filter' screen for the Event Log. At the top, there are four buttons: a home icon, 'Logs', 'Event Log', and 'Filter'. Below these, the 'Event Time' section has a radio button selected for 'Last' and a dropdown menu set to 'All Logs'. The 'From' section has two input fields: '01/01/2001' and '00:00'. The 'to' section has two input fields: '09/27/2016' and '13:10'. Under 'Filter by Severity', there are three checkboxes: 'Show Critical Events' (checked), 'Show Warning Events' (unchecked), and 'Show Informational Events' (unchecked). At the bottom, there are two buttons: 'Device Events' and 'System Events'. In the bottom right corner, there are 'ESC' and 'OK' buttons. A small vertical text 'na6294a' is visible on the right edge of the screen.

The filter options for related **Device Events** are the following:

- Communication
- Temperature
- Fans
- Status
- Diagnostics
- Humidity
- Configuration

The filter options for related **System Events** are the following:

- Mass Configuration
- Security

Clear Event Log

Path: Main > Logs > Event Log

1. Press the trash can icon in the bottom-left corner of the **Event Log** screen to clear the log. A confirmation screen is displayed.
2. Enter the Admin password to clear the log.
3. Select **Yes** to clear all of the events in the log. Select **No** to return to the **Event Log** screen.

Data Log

Path: Main > Logs > Data Log > Graphing

The **Data Log** is a graph showing the changes over time of selected readings. Select the data point to graph and press **+** to add the data point to the graph. To remove a data point from the graph, select the data point from the list and press **-**. To clear the graph, press **CLR**.

NOTE: Image is an example only; your screen may differ.

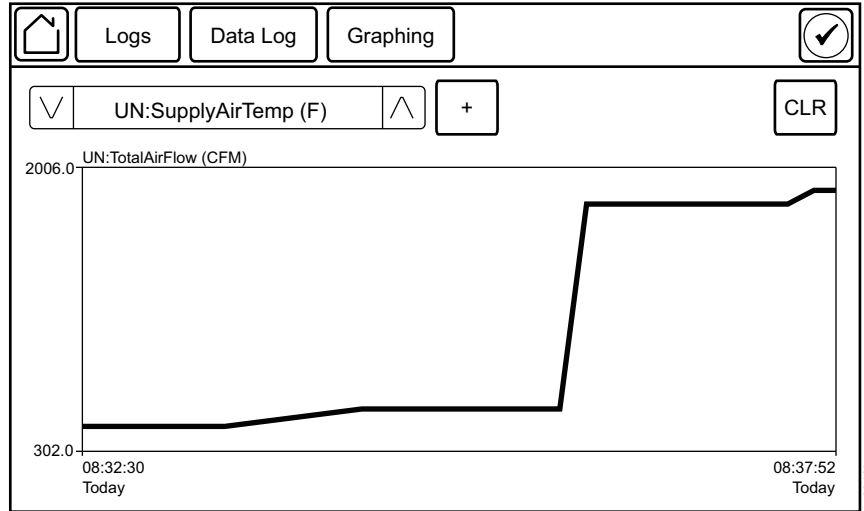

Data Log Configuration

Select at what intervals (**Log Interval**) the data log will record an entry. When the size of the data log reaches the **Data Log Size** entry limit, the log will overwrite itself by deleting the first half of the data and continuing recording as normal.

Export Data

Path: Main > Logs > Export Data

The data export function exports a .tar file containing the following files:

- config.ini
- data.txt
- debug.txt
- event.txt

1. Insert a USB drive into the USB port of the display interface.
2. Press **Start Data Export**.
3. Confirm exporting the data to the USB drive.
4. Wait for the data to export or abort exporting by pressing **Abort Data Export**.
5. Press **OK** when the “Data exported successfully. Remove USB device.” message displays.
6. Remove the USB drive from the display interface.

Alarms

Respond to Alarms

When an alarm is triggered, the unit provides alerts through the display in the following methods:

- LEDs on the display interface
- Alarm icon in the upper-right corner of the screen
- An optional audible alarm every 30 seconds if enabled

View Active Alarms

The **Active Alarms** screen is accessed by pressing the alarm icon in the upper-right corner of the screen. The **Active Alarms** screen provides the number of alarms, the severity, and a brief description of the alarm.

Clear Active Alarms

1. Press **Clear** to clear the active alarms.
A confirmation screen is displayed.
2. Enter the Admin password to erase the alarms list.
3. Select **Yes** to erase all of the alarms. Select **No** to return to the **Active Alarms** screen.

Alarm Thresholds

Path: Main > Configuration > Unit > Alarms > Thresholds

Thresholds can be set to activate alarms to alert you to violations when the threshold is exceeded.

- **Supply Air High Temperature Threshold:** The high temperature threshold for the supply air as averaged by the supply air temperature sensors. If the temperature exceeds this threshold, an alarm will occur. (0–100°C (32–212°F))
- **Rack Inlet High Temperature Threshold:** The high temperature threshold for the rack inlet air temperature as averaged by the rack inlet temperature sensors. If the temperature exceeds this threshold, an alarm will occur. (0–100°C (32–212°F))
- **Return Air High Temperature Threshold:** The high temperature threshold for the air entering the cooling unit. If the temperature exceeds this threshold, an alarm will occur. (0–100°C (32–212°F))
- **Return Humidity High Threshold:** The relative humidity at which the high threshold alarm occurs. (35–90%RH)
- **Return Humidity Low Threshold:** The relative humidity at which the low threshold alarm occurs. (20–50%RH)
- **Clogged Filter Thresh.:** The pressure at which a clogged filter alarm occurs. (24.88–236.40 Pa (0.10–0.95 in. WC))

Alarm Messages and Suggested Actions

Alarm Message	Severity	Action Required
AFC Fault	Warning	Contact Schneider Electric Technical Support.
AFC Firmware Revision Compatible	Critical	<ul style="list-style-type: none"> Check revision of AFC firmware. If the problem persists, contact Schneider Electric Technical Support.
Air Filter Clogged	Warning	<ul style="list-style-type: none"> Clean or replace the air filter. If the problem persists, contact Schneider Electric Technical Support.
Air Filter Has Exceeded Runtime Threshold	Warning	Reset the Air Filter Run Hours after the air filter is cleaned or replaced.
Air Filter Pressure Sensor Failed	Warning	<ul style="list-style-type: none"> Check the sensor connection. If the problem persists, contact Schneider Electric Technical Support.
Coil Freezing	Warning	If the problem persists, contact Schneider Electric Technical Support.
Condensate Pan Full	Warning	A hardware problem may exist: Contact Schneider Electric Technical Support.
Condensate Pan Overflowing	Critical	A hardware problem may exist: Contact Schneider Electric Technical Support.
Condenser Communication Failure	Critical	<ul style="list-style-type: none"> Check the RS485 connection to the outdoor unit. Check power to outdoor unit. If the problem persists, contact Schneider Electric Technical Support.
Condensate Pan Pump Control Failed	Critical	Contact Schneider Electric Technical Support.
CPY: EA: Foam Alarm	Warning	Contact Schneider Electric Technical Support.
Discharge Pressure Sensor Failed	Warning	<ul style="list-style-type: none"> Check the sensor connection. If the problem persists, contact Schneider Electric Technical Support.
Discharge Pressure Too High	Critical	<ul style="list-style-type: none"> Check condenser for obstructions. If the problem persists, contact Schneider Electric Technical Support.
EcoAisle Door Open	Warning	<ul style="list-style-type: none"> Verify the aisle containment system door is shut properly. If the problem persists, contact Schneider Electric Technical Support.
Evaporator Fan Power Supply Failure	Critical	Contact Schneider Electric Technical Support.
Evaporator Fan Power Supply 'X' Failure	Warning	Contact Schneider Electric Technical Support.
EXV Error	Critical	Contact Schneider Electric Technical Support.
Fan #s Fault	Warning	A hardware problem may exist: Contact Schneider Electric Technical Support.
High Discharge Pressure Persistent	Critical	<ul style="list-style-type: none"> Indicates there were four Compressor High Pressure shutdowns in 30 minutes. Alarms must be cleared manually. If the problem persists, contact Schneider Electric Technical Support.

Alarm Message	Severity	Action Required
Humidifier (CL) Cylinder Depleted	Warning	Contact Schneider Electric Technical Support.
Humidifier (CP) Excessive Scaling	Warning	Contact Schneider Electric Technical Support.
Humidifier (E0) Configuration Parameters Corrupt	Warning	Contact Schneider Electric Technical Support.
Humidifier (E1) Parameters not Downloaded	Warning	Contact Schneider Electric Technical Support.
Humidifier (E2) Backup Memory Error	Warning	Contact Schneider Electric Technical Support.
Humidifier (EC) Water Conductivity High	Warning	Contact Schneider Electric Technical Support.
Humidifier (EH) Electrode Current High	Warning	Contact Schneider Electric Technical Support.
Humidifier (EP) Steam Flow Low	Warning	Contact Schneider Electric Technical Support.
Humidifier (EU) Water Level High	Warning	Contact Schneider Electric Technical Support.
Humidifier Communication Error	Critical	Contact Schneider Electric Technical Support.
Humidifier Cylinder Life	Warning	Contact Schneider Electric Technical Support.
Humidifier Drain Error	Warning	Contact Schneider Electric Technical Support.
Humidifier Water Loss	Warning	Contact Schneider Electric Technical Support.
Humidity is Below Threshold	Warning	Contact Schneider Electric Technical Support.
Humidity is Above Threshold	Critical	Contact Schneider Electric Technical Support.
Inlet Evap Coil Temperature Sensor Failed	Warning	<ul style="list-style-type: none"> • Check the sensor connection. • If the problem persists, contact Schneider Electric Technical Support.
Input Voltage Has Not Been Configured	Critical	<ul style="list-style-type: none"> • Check the Voltage setting in the Main > On/Off menu. • If the problem persists, contact Schneider Electric Technical Support.
Insufficient Air Flow	Warning	<ul style="list-style-type: none"> • Verify the air ports are clear of obstructions and there is sufficient cooling capacity for the load. • If the problem persists, contact Schneider Electric Technical Support.
Internal Communication Error	Critical	A hardware problem may exist: Contact Schneider Electric Technical Support.
Leak Detected	Critical	<ul style="list-style-type: none"> • System is configured to enter idle mode when leak has been detected. Identify the source of the leak. • If the problem persists, contact Schneider Electric Technical Support
Low Suction Pressure Persistent	Critical	A hardware problem may exist: Contact Schneider Electric Technical Support.
Lower Return Temperature Sensor Failed	Warning	<ul style="list-style-type: none"> • Check the sensor connection. • If the problem persists, contact Schneider Electric Technical Support.
Lower Supply Temperature Sensor Failed	Warning	<ul style="list-style-type: none"> • Check the sensor connection. • If the problem persists, contact Schneider Electric Technical Support.

Alarm Message	Severity	Action Required
No Standby Units Available	Warning	<ul style="list-style-type: none"> Check to make sure cooling units in the group have the Unit Role Override setting on the Main > On/Off screen is set to Automatic and that cooling units are available (not in a failed state). Check that the Number of Backup Units in the Main > Configuration > Group > Composition menu is not set to zero (0). If the problem persists, contact Schneider Electric Technical Support.
Outlet Evap Coil Temperature Sensor Failed	Warning	<ul style="list-style-type: none"> Check the sensor connection. If the problem persists, contact Schneider Electric Technical Support.
Output Relay # is Active	Informational	Informational message only: no action required.
PIC# Firmware Revision Incompatibility	Critical	<ul style="list-style-type: none"> Check revision of PIC firmware. If the problem persists, contact Schneider Electric Technical Support.
Primary Power Source Failed	Warning	<ul style="list-style-type: none"> Check power source. If the problem persists, contact Schneider Electric Technical Support.
Rack Inlet Temperature is Above Threshold	Warning	<ul style="list-style-type: none"> Make sure the temperature sensor is connected and placed properly. Make sure the Rack Inlet High Temperature Threshold is set correctly in the Main > Configuration > Unit > Alarms > Thresholds menu. If the problem persists, contact Schneider Electric Technical Support.
Return Temperature is Above Threshold	Warning	<ul style="list-style-type: none"> Make sure the Return Air High Temperature Threshold is set correctly in the Main > Configuration > Unit > Alarms > Thresholds menu. If the problem persists, contact Schneider Electric Technical Support.
Room Humidity Sensor Failed	Warning	<ul style="list-style-type: none"> Check the sensor connection. If the problem persists, contact Schneider Electric Technical Support.
Secondary Power Source Failed	Warning	<ul style="list-style-type: none"> Check power source. If the problem persists, contact Schneider Electric Technical Support.
Suction Pressure Sensor Failed	Warning	A hardware problem may exist: Contact Schneider Electric Technical Support.
Suction Pressure Too Low	Critical	<ul style="list-style-type: none"> Check the air filter and the evaporator for obstructions. If the problem persists, contact Schneider Electric Technical Support.
Suction Pressure Too Low to Start	Critical	A hardware problem may exist: Contact Schneider Electric Technical Support.
Superheat High or Low Persistent	Critical	Contact Schneider Electric Technical Support.
Superheat Too High	Critical	Contact Schneider Electric Technical Support.

Alarm Message	Severity	Action Required
Superheat Too Low	Critical	Contact Schneider Electric Technical Support.
Supply Temperature is Above Threshold	Critical	<ul style="list-style-type: none"> Make sure the Supply Air High Temperature Threshold is set correctly in the Main > Configuration > Unit > Alarms > Thresholds menu. If the problem persists, contact Schneider Electric Technical Support
Too Many Compressor Short Cycles	Warning	Contact Schneider Electric Technical Support.
Unexpected Number of AFCs	Warning	<ul style="list-style-type: none"> Verify physical number of AFC units is set correctly in the Main > Configuration > Service > Containment Systems. If the problem persists, contact Schneider Electric Technical Support.
Unexpected Number of Units in Group	Warning	<ul style="list-style-type: none"> Check group CAN connection. Verify the number of units within the group is correct (Main > Configuration > Group > Composition). If problem persists, contact Schneider Electric Technical Support
Unit Has Exceeded Runtime Threshold	Warning	<ul style="list-style-type: none"> Service the unit. If the problem persists, contact Schneider Electric Technical Support.
Unit is Idle	Critical	A hardware problem may exist: Contact Schneider Electric Technical Support.
Unit Off Due to Input Contact	Warning	<ul style="list-style-type: none"> For an abnormal condition, check the remote contact switch and wiring for proper operation. For a normal condition, no action required.
Upper Return Temperature Sensor Failed	Warning	<ul style="list-style-type: none"> Check the sensor connection. If the problem persists, contact Schneider Electric Technical Support.
Upper Supply Temperature Sensor Failed	Warning	<ul style="list-style-type: none"> Check the sensor connection. If the problem persists, contact Schneider Electric Technical Support.
VFD Communication Failed	Critical	<ul style="list-style-type: none"> Check the RS485 connection to the outdoor unit. Check power to outdoor unit. If problem persists, contact Schneider Electric Technical Support
VFD Control Card Over Temperature	Critical	Contact Schneider Electric Technical Support.
VFD Control Card Over Temperature Warning	Warning	Contact Schneider Electric Technical Support.
VFD Control Voltage Overloaded	Warning	Contact Schneider Electric Technical Support.
VFD Current Limit Exceeded	Warning	Contact Schneider Electric Technical Support.
VFD Current Overload	Critical	Contact Schneider Electric Technical Support.
VFD Current Overload Warning	Warning	Contact Schneider Electric Technical Support.
VFD DC Link Voltage High	Warning	Contact Schneider Electric Technical Support.

Alarm Message	Severity	Action Required
VFD DC Link Voltage Low	Warning	Contact Schneider Electric Technical Support.
VFD DC Overvoltage	Critical	Contact Schneider Electric Technical Support.
VFD DC Overvoltage Warning	Warning	Contact Schneider Electric Technical Support.
VFD DC Undervoltage Warning	Warning	Contact Schneider Electric Technical Support.
VFD Drive Initialized To Defaults	Critical	Contact Schneider Electric Technical Support.
VFD Earth Fault	Critical	Contact Schneider Electric Technical Support.
VFD High Head Pressure Switch Activated	Critical	Contact Schneider Electric Technical Support.
VFD Inrush Error	Critical	Contact Schneider Electric Technical Support.
VFD Internal Error	Critical	Contact Schneider Electric Technical Support.
VFD Initialization Error	Critical	Contact Schneider Electric Technical Support.
VFD Mains Phase Loss	Critical	Contact Schneider Electric Technical Support.
VFD Motor Over Temperature	Critical	Contact Schneider Electric Technical Support.
VFD Motor Phase U Missing	Critical	Contact Schneider Electric Technical Support.
VFD Motor Phase V Missing	Critical	Contact Schneider Electric Technical Support.
VFD Motor Phase W Missing	Critical	Contact Schneider Electric Technical Support.
VFD Motor Thermistor Over Temperature	Critical	Contact Schneider Electric Technical Support.
VFD Peak Over Current	Critical	Contact Schneider Electric Technical Support.
VFD Persistent Trips	Critical	Contact Schneider Electric Technical Support.
VFD Power Card Temperature OK	Critical	Contact Schneider Electric Technical Support.
VFD Short Circuit	Critical	Contact Schneider Electric Technical Support.
VFD Speed Not Within Limits	Warning	Contact Schneider Electric Technical Support.
VFD Torque Limit Exceeded	Critical	Contact Schneider Electric Technical Support.
VFD Vd D1 Supply Low	Critical	Contact Schneider Electric Technical Support.
Wrong Number of Leak Detector Sensors	Warning	<ul style="list-style-type: none"> • Check the Number of Leak Detectors in Unit setting in the Main > Configuration > Unit > Components menu. • If the problem persists, contact Schneider Electric Technical Support.

Network Management Card

Quick Configuration

The unit is shipped with a Network Management Card that enables the unit to be managed over a network. Configure the Network Management Card to control this unit through a network.

Overview

The following TCP/IP settings must be configured before the Network Management Card can operate on a network:

- IP address of the Network Management Card
- Subnet mask
- Default gateway

NOTE: Never use the loopback address (127.0.0.1) as the default gateway address for the Network Management Card. Doing so will disable the card and will require to reset TCP/IP settings to their defaults using a local serial login.

NOTE: If a default gateway is unavailable, use the IP address of a computer that is located on the same subnet as the Network Management Card and that is usually running. The Network Management Card uses the default gateway to test the network when traffic is very light.



See “Watchdog Features” in the “Introduction” of the *User Manual* or *Online Guide* for more information about the watchdog role of the default gateway.

TCP/IP Configuration Methods

Use one of the following methods to define the TCP/IP settings needed by the Network Management Card:

- Device IP Configuration Wizard (See Device IP Configuration Wizard, page 75 for more information.)
- BootP or DHCP server (See BootP and DHCP Configuration, page 75 for more information.)
- Local computer (See Local Access to the Command Line Interface (CLI), page 78 for more information.)
- Networked computer (See Remote Access to the Command Line Interface (CLI), page 77 for more information.)

Device IP Configuration Wizard

The Device IP Configuration Wizard is used to discover and configure Network Management Cards that do not have IP addresses assigned. The Device IP Configuration Wizard runs on Microsoft® Windows® 2000, Windows 2003, Windows Server® 2003, Windows Server 2012, and on 32- and 64-bit versions of Windows XP, Windows Vista, Windows 2008, Windows 7, Windows 8, Windows 10, and Windows 2012 operating systems.

The Device IP Configuration Wizard supports network management cards that have firmware version 3.x.x or higher and is for IPv4 only.

NOTE: Most software Firewalls must be temporarily disabled for the Wizard to discover Network Management Cards that are not configured.



To configure one or more Network Management Cards from a user configuration file, see the *User Manual* or *Online Guide*.

1. Download the Device IP Configuration Wizard from www.schneider-electric.com or www.apc.com (search for “Device IP Configuration Wizard”).
2. Install and run the Device IP Configuration Wizard.
3. Follow the on-screen instructions.

NOTE: If the option **Start a Web browser when finished** is enabled, the word `apc` (the default) can be used for both the user name and password.

.ini File Utility

The .ini file export utility can be used to export .ini file settings from configured Network Management Cards to one or more unconfigured Network Management Cards.

BootP and DHCP Configuration

The default **TCP/IP Configuration, DHCP**, assumes that a properly configured DHCP server is available to provide TCP/IP settings to Network Management Cards. The possible settings are **Manual, DHCP**, or **BOOTP**.



If neither a DHCP nor BOOTP server is available, see *Device IP Configuration Wizard*, page 75 or *Remote Access to the Command Line Interface (CLI)*, page 77 for more information on how to configure the TCP/IP settings.

BOOTP: For the Network Management Card to use a BOOTP server to configure its TCP/IP settings, it must find a properly-configured RFC951-compliant BOOTP server.

1. In the BOOTPTAB file of the BOOTP server, enter the MAC address of the Network Management Card, and the IP addresses of the subnet mask and default gateway, and an optional bootup file name.

NOTE: Look on the nameplate of the unit for the MAC address. The MAC address is also available on the display interface at **Main > About > Display > Device**

2. When the Network Management Card reboots, the BOOTP server provides it with the TCP/IP settings.
 - If a bootup file name is specified, the Network Management Card attempts to transfer that file from the BOOTP server using TFTP or FTP. The Network Management Card takes on all settings specified in the bootup file.
 - Whereas if a bootup file name is not specified, the Network Management Card can be configured remotely by using the CLI or the Web interface. User name and password are both `apc`, by default.



To create the bootup file, see the BOOTP server documentation.

DHCP: A RFC2131/RFC2132-compliant DHCP server can be used to configure the TCP/IP settings for the Network Management Card.



For more details on how a DHCP can configure the network settings for a Network Management Card, see “DHCP Configuration” in the *Online Guide*.

1. The Network Management Card sends out a DHCP request that uses the following to identify itself:
 - Vendor Class Identifier (by default, APC)
 - Client Identifier (by default, the MAC address of the Network Management Card)
 - User Class Identifier (by default, the identification of the application firmware installed on the Network Management Card)
2. A properly configured DHCP server responds with a DHCP offer that includes all of the settings that the Network Management Card needs for network communication. The DHCP offer also includes the Vendor Specific Information option (DHCP option 43). If configured to do so, the Network Management Card will ignore DHCP offers that do not encapsulate the APC cookie in DHCP option 43 using the following hexadecimal format:

Option 43 = 01 04 31 41 50 43

where

- The first byte (01) is the code
- The second byte (04) is the length
- The remaining bytes (31 41 50 43) are the APC cookie (not required by default)



See the DHCP server documentation to add code to the Vendor Specific Information option.

To change the command line interface (CLI) DHCP Cookie Is setting, use the Advanced option in the TCP/IP menu.



See *Local Access to the Command Line Interface (CLI)*, page 78 for more information.

Command Line Interface (CLI)

The Command Line Interface (CLI) can be used to view the status of and configure and manage the unit. In addition, the CLI allows for creating scripts for automated operation. All parameters of the unit (including those for which there are not specific CLI commands) can be configured by using the CLI to transfer an INI file to the unit. The CLI uses XMODEM to perform the transfer, however, the current INI file cannot be read through XMODEM.

Remote Access to the Command Line Interface (CLI)

From any computer on the same network as the Network Management Card, ARP and Ping can be used to assign an IP address to the Network Management Card and then use Telnet to access the CLI of that Network Management Card and configure the other TCP/IP settings.

NOTE: After a Network Management Card has its IP address configured, Telnet can be used, without first using ARP and Ping, to access that Network Management Card.

1. Use the MAC address of the Network Management Card in the ARP command to define an IP address for the Network Management Card. For example, to define an IP address of 156.205.14.141 for a Network Management Card that has a MAC address of 00 c0 b7 63 9f 67, use one of the following commands:

NOTE: Look on the nameplate of the unit for the MAC address. The MAC address is also available on the display interface at **Main > About > Display > Device**.

- Windows command format:

```
arp -s 156.205.14.141 00-c0-b7-63-9f-67
```

- LINUX command format:

```
arp -s 156.205.14.141 00:c0:b7:63:9f:67
```

2. Use Ping with a size of 113 bytes to assign the IP address defined by the ARP command. For the IP address defined in step 1, use one of the following Ping commands:

- Windows command format:

```
ping 156.205.14.141 -l 113
```

- LINUX command format:

```
ping 156.205.14.141 -s 113
```

3. Use Telnet to access the Network Management Card at its newly assigned IP address. For example,

```
telnet 156.205.14.141
```

4. Use `apc` for both the user name and password.

5. Contact the network administrator to obtain the IP address, subnet mask, and default gateway for the Network Management Card.

6. Use these three commands to configure network settings (text in *italics* indicates a variable):

a. `tcpip -i yourIPAddress`

b. `tcpip -s yourSubnetMask`

c. `tcpip -g yourDefaultGateway`

For each variable, enter a numeric value with the format xxx.xxx.xxx.xxx.

For example, to set a system IP address of 156.205.14.141, enter the following command and press **ENTER**:

```
tcpip -i 156.205.14.141
```

7. Type `reboot`. The Network Management Card restarts to apply the changes.

Local Access to the Command Line Interface (CLI)

It is possible to use a computer connected to the serial port on the front of the display to access the CLI.

1. Select a serial port on the local computer and disable any service that uses that port.
2. Use the provided serial cable to connect the selected serial port to the serial on the front of the display.
3. Run a terminal program (such as HyperTerminal®, TeraTerm, or PuTTY) and configure the selected port for 9600 bps, 8 data bits, no parity, 1 stop bit, and no flow control.
4. Save the changes.
5. Press **ENTER**, repeatedly if necessary, to display the **User Name** prompt.
6. Use `apc` for the user name and password.
7. Contact the network administrator to obtain the IP address, subnet mask, and default gateway for the Network Management Card.
8. Use these three commands to configure network settings (text in *italics* indicates a variable):
 - a. `tcpip -i yourIPAddress`
 - b. `tcpip -s yourSubnetMask`
 - c. `tcpip -g yourDefaultGateway`

For each variable, enter a numeric value with the format `xxx.xxx.xxx.xxx`. For example, to set a system IP address of 156.205.14.141, enter the following command and press **ENTER**:

```
tcpip -i 156.205.14.141
```

9. Type `reboot`. The Network Management Card restarts to apply the changes.

How to Use the CLI

At the command line interface, use commands to view and configure settings for the appliance. To use a command, type the command, option (if applicable), and any applicable arguments, then press **ENTER**. Commands and arguments are valid in lowercase, uppercase, or mixed case. Options are case sensitive.

While using the CLI, it is also possible to do the following:

- Type `?` and press **ENTER** to view a list of available commands, based on the account type.
- To obtain information about the purpose and syntax of a specified command, type the command, a space, and `?` or the word `help`. For example, to view RADIUS configuration options, type

```
radius ?
```

or

```
radius help
```

NOTE: See for more detailed information.
- Press the UP arrow key to view the command that was entered most recently in the session. Use the UP and DOWN arrow keys to scroll through a list of up to ten previous commands.
- Type at least one letter of a command and press the TAB key to scroll through a list of valid commands that match the text typed in the command line.
- Type `exit`, `quit`, or `bye` to close the connection to the CLI.

Command Help Syntax

When using `?` or `help` to obtain information about a specific command, the following syntax defines how that command can be used:

Item	Description
-	Options are preceded by a hyphen.
[...]	If a command accepts multiple options or an option accepts mutually exclusive arguments, the values may be enclosed in brackets.
<...>	Definitions of options are enclosed in angle brackets. For example: <code>-dp <device password></code>
	A vertical line between items enclosed in brackets or angle brackets indicates that the items are mutually exclusive. One of the items must be used.

Example of a command that supports multiple options:

```
ftp [-p <port number>] [-S <enable | disable>]
```

In this example, the `ftp` command accepts the option `-p`, which defines the port number, and the option `-S`, which enables or disables the FTP feature.

To change the FTP port number to 5010, and enable FTP:

1. Type the `ftp` command, the port option, and the argument 5010:

```
ftp -p 5010
```

2. After the first command succeeds, type the `ftp` command, the enable/disable option, and the enable selection:

```
ftp -S enable
```

Example of a command that accepts mutually exclusive arguments for an option:

```
alarmcount -p [all | warning | critical]
```

In this example, the option `-p` accepts only three arguments: `all`, `warning`, or `critical`. For example, to view the number of active critical alarms, type:

```
alarmcount -p critical
```

The command will fail if typing an argument that is not specified.

Command Response Codes

The command response codes enable scripted operations to detect error conditions reliably without having to match error message text. All CLI commands issue:

```
<three digit response code>:<space> (followed by a readable response message)
```

This can be followed by `<cr><lf>` and the output of the command (if applicable).

Example: `E000: Success` (followed by the output of the command, if applicable)

Successful command operations have a response code less than 100. Any response code of 100 or greater indicates an error of some type.

```
E [0-9] [0-9] [0-9]: Error message
```

Argument Quoting

Argument values may optionally be enclosed in double quote characters (ASCII 0x22). String values beginning or ending with spaces, or containing commas or semicolons, must be enclosed in quotes for both input and output. Quote and backslash ("`\`", decimal code 92) characters appearing inside strings should NOT be encoded using traditional escape sequences (see Escape Sequences below).

All binary characters (ASCII decimal ranges 0..31, 127..159) that appear inside strings are treated as unreadable characters and rejected. When a quote or backslash character is supplied as a part of an input string, the input string must be enclosed in double quotes.

Escape Sequences

Escape sequences, traditionally a backslash followed by a lower case letter or by a combination of digits, are ignored and should not be used to encode binary data or other special characters and character combinations.

The result of each escape sequence is parsed as if it were both a backslash and the traditionally escaped character.

Example: <command> <arg1> [<arg2> <arg3a | arg3b> [<arg4a | arg4b | arg4c>]]

- arg1 must be used, but arg2 - 4 are optional.
- If arg2 is used, then arg3a or arg3b must also be used.
- arg4 is optional, but arg1 - 3 must precede arg4.

With most commands, if the last argument is omitted, the command provides information, otherwise the last argument is used to change/set new information.

Example:

```
apc>ftp -p (displays the port number when omitting the arg2)
```

```
E000: Success
FTP Port: 5001
```

```
apc>ftp -p 21 (sets the port number to arg2)
E000: Success
```

Prompts for User Input during Command Execution

Certain commands require additional user input (ex. transfer .ini prompting for baud rate). There is a fixed timeout of 1 minute for such prompts. If any text is entered within the timeout period, then the command prints E100: Command Failed. and the command prompt is redisplayed.

Delimiter

The CLI uses <space> (ASCII 0x20) as the delimiter between commands and arguments. Extra white space between commands and arguments is ignored.

Command responses have all fields delimited with commas for efficient parsing.

Option and Argument Inputs

Entering a command with no options or arguments returns the current value of all options available from that command.

Entering the command and an option with no arguments returns the current value of that option only.

Any command followed by a question mark ? returns help explaining the command.

```
<space> :: = (" | multiple" )
```

```
<valid letter_number> :: = (a-z | A-Z | 0-9)
```

```
<string> :: = (1 - 64 consecutive printable valid ASCII characters [ranging from hex 0x20 to 0x7E inclusive] )
```

NOTE: If the string includes a blank, the entire string MUST be surrounded by quotes(" ").

```
<option> ::= "-"(<valid letter_number> | <valid letter_number><valid letter_number>)  
  
<argument> ::= <helpArg> | <alarmcountArg> | <bootArg> | <cdArg>  
| <consoleArg> | <dateArg> | <deleteArg> | <ftpArg> | <pingArg> |  
<portspeedArg> | <promptArg> | <radiusArg> | <resettodefArg> |  
<systemArg> | <tcpipArg> | <userArg> | <webArg> | <string>  
  
<optionArg> ::= <option><argument>
```

Network Management Card Command Descriptions

? or help

Access: Super User, Administrator, Device User, Read Only User

Description: View a list of all the CLI commands available to the user account type. To view help text for a specific command, type the command followed by a question mark.

Parameters: [<command>]

Example 1:

```
apc> ?
System Commands:
-----
For command help: command ?
?          about      alarmcount  boot        bye          cd
cipher     clrrst     console     date        delete       dir
dns        email      eventlog    exit        firewall     format
ftp        help       lang        lastrst     ledblink     logzip
netstat    ntp        ping        portspeed   prompt       pwd
quit       radius     reboot      resetToDef  session      smtp
snmp       snmptrap   snmpv3      system      tcpip        tctpip6
user       userdflt   web         whoami      xferINI      xferStatus
```

Example 2:

```
apc> help boot
Usage: boot -- Configuraiton Options
boot    [-b <dhcpBootp | dhcp | bootp | manual>] (IPv4 Boot Mode)
        [-c <enable | disable>] (Require DHCPv4 Cookie)
        [-v <vendor class>]
        [-i <client id>]
        [-u <user class>]
```

Error Message: E000, E102

about

Access: Super User, Administrator, Device User, Read Only User

Description: Displays system information (Model Number, Serial Number, Manufacture Dates, etc.)

Parameters: None.

Example:

```
apc> about
E000: Success
-----
Model Number:                AP9XXX
Serial Number:                ST0913012345
Hardware Revision:            HW05
Manufacture Date:             6/23/2018
MAC Address:                  00 05 A2 18 00 01
Management Uptime:           0 Days 1 Hour 42 Minutes
```

```
Network Management Card
-----
Model Number:                AP9538
Serial Number:                5A1751T81927
```

```
Application Module
-----
Name:                        nb250
Version:                     v6.7.2.
Date:                         Feb 5 2019
Time:                         17:27:33
```

```
APC OS (AOS)
-----
Name:                        aos
Version:                     v6.7.2
Date:                         Jan 24 2019
Time:                         16:59:36
```

```
APC Boot Monitor
-----
Name:                        bootmon
Version:                     v1.0.8
Date:                         Apr 8 2014
Time:                         10:59:40
```

Error Message: E000

alarmcount

Access: Super User, Administrator, Device User, Read Only User

Description: Displays alarms present in the system.

Parameters:

Option	Argument	Description
-p	all	View the number of active alarms reported by the Rack. Information about the alarms is provided in the event log.
	warning	View the number of active warning alarms.
	critical	View the number of active critical alarms.

Example: To view all active warning alarms, type:

```
apc> alarmcount  
E000: Success  
AlarmCount: 0
```

Error Message: E000, E102

boot**Access:** Super User, Administrator**Description:** View or set the network startup configuration of the device, such as setting boot mode (DHCP vs BOOTP vs MANUAL).**Parameters:**

Option	Argument	Description
-b <boot mode>	dhcp bootp manual	Define how the TCP/IP settings will be configured when the turns on, resets, or restarts. for information about each boot mode setting.
-c	[<enable disable>] (Require DHCP Cookie)	dhcp boot mode only. Enable or disable the requirement that the DHCP server provide the APC cookie.
-v	[<vendor class>]	Vendor Class is APC.
-i	[<client id>]	The MAC address of the 's NMC, which uniquely identifies it on the network.
-u	[<user class>]	The name of the application firmware module.

Example:

```

apc> boot

E000: Success

Boot Mode:      manual
DHCP Cookie:    enable
Vendor Class:   <device class>
Client ID:      XX XX XX XX XX XX
User Class:     <user class>

```

Error Message: E000, E102

bye, exit, or quit

Access: Super User, Administrator, Device User, Read Only User

Description: Exit the CLI.

Parameters: None.

Example 1:

```
apc> bye
Bye
```

Example 2:

```
apc> exit
Bye
```

Example 3:

```
apc> quit
Bye
```

Error Message: None.

cd

Access: Super User, Administrator, Device User, Read Only User

Description: Allows the user to set the working directory of the file system. The working directory is set back to the root directory '/' when the user logs out of the CLI.

Parameters: <directory name>

Example:

```
apc> cd logs
E000: Success
```

```
apc> cd /
E000: Success
```

Error Message: E000, E102

cipher

Access: Super User, Administrator

Description: Enable or disable cryptographic algorithms for Web UI sessions. These algorithms cannot be enabled or disabled directly from the Web UI. The NMC must be rebooted after enabling or disabling algorithms for changes to take effect.

There are three categories of algorithms: Authentication algorithms, Block Cipher algorithms, and MAC algorithms. Available and Blocked Cipher Suites are also listed.

NOTE: Disabling the only algorithm will block all SSL/TLS sessions and HTTPS access may not work depending on the browser used and its configuration.

Parameters:

Option	Argument	Description
-3des	enable disable	Enable or disable Triple DES.
-aes	enable disable	Enable or disable Advanced Encryption Standard (AES).
-dh	enable disable	Enable or disable Diffie-Hellman (DH).
-rsake	enable disable	Enable or disable RSA key exchange.
-rsaau	enable disable	Enable or disable RSA authentication.
-sha1	enable disable	Enable or disable Secure Hash Algorithm 1 (SHA-1).
-sha2	enable disable	Enable or disable Secure Hash Algorithm 2(SHA-2).
-ecdhe	enable disable	Enable or disable Elliptic Curve Diffie-Hellman Exchange (ECDHE).

Example 1: Disable the triple-DES block cipher.

```
apc> cipher -3des
E000: Success
Reboot required for change to take effect.
```

Error Message: E000, E102

clrrst

Access: Super User, Administrator

Description: Clear reset reason.

Parameters: None.

Example:

```
apc> clrrst
E000: Success
```

Error Message: E000

console

Access: Super User, Administrator

Description: Define whether users can access the CLI using Telnet, which is enabled by default, or Secure SHell (SSH), which provides protection by transmitting user names, passwords, and data in encrypted form. The Telnet or SSH port setting can be changed for additional security. Alternately, disable network access to the CLI.

Parameters:

Option	Argument	Description
-s	<enable disable> (ssh)	Enable or disable access to the CLI through SSH. Enabling SSH enables SCP.
-t	<enable disable> (telnet)	Disable or enable access to the CLI through Telnet.
-pt	<telnet port n>	Define the Telnet port used to communicate with the (23 by default).
-ps	<SSH port n>	Define the SSH port used to communicate with the (22 by default).
-b	2400 9600 19200 38400	Configure the speed of the serial port connection (9600 bps by default).

Example 1: To enable SSH access to the CLI, type

```
apc> console -s enable
E002: Success
Reboot required for change to take effect.
```

Example 2: To change the Telnet port to 5000, type

```
apc> console -pt 5000
E000: Success
Reboot required for change to take effect.
```

Error Message: E000, E102

date

Access: Super User, Administrator

Description: Get and set the date and time of the system. .

Parameters:

Option	Argument	Description
-d	<"datestring">	Set the current date. The format must match the current -f setting.
-t	<00:00:00>	Configure the current time, in hours, minutes, and seconds. Use the 24-hour clock format.
-f	<mm/dd/yy dd.mm.yyyy mmm-dd-yy dd-mmm-yy yyyy-mm-dd>	Select the numerical format in which to display all dates in this user interface. Each letter m (for month), d (for day), and y (for year) represents one digit. Single-digit days and months are displayed with a leading zero.
-z	<time zone offset>	Set the difference with Greenwich Mean Time (GMT) in order to specify the time zone needed. This allows the synchronization with other people in different time zones.

Example 1: To display the date using the format yyyy-mm-dd, type

```
apc> date -f yyyy-mm-dd
E000: Success
* Reboot required for change to take effect
```

Example 2: To define the date as July 1, 2018, type

```
apc> date -d "2018-07-01"
E000: Success
* Reboot required for change to take effect
```

Example 3: To define the time as 5:21:03 p.m., type

```
apc> date -t 17:21:03
E000: Success
* Reboot required for change to take effect
```

Error Message: E000, E100, E102

delete

Access: Super User, Administrator

Description: Delete a file in the file system.

Parameters:

Argument	Description
<file name>	Type the name of the file to delete.

Example:

```
apc> delete /event.txt
E000: Success
```

Error Message: E000, E102

dir

Access: Super User, Administrator, Device User, Read Only User

Description: Displays the content of the working directory.

Parameters: None.

Example:

```
apc> dir
E000: Success
--wx-wx-wx 1 apc      apc      3145728 Jun 23 2018 aos.bin
--wx-wx-wx 1 apc      apc      3145728 Jun 23 2013 app.bin
-rw-rw-rw- 1 apc      apc      45000 Jul 1 2018 config.ini
drwxrwxrwx 1 apc      apc           0 Mar 18 2018 ssl/
drwxrwxrwx 1 apc      apc           0 Mar 18 2018 ssh/
drwxrwxrwx 1 apc      apc           0 Mar 18 2018 logs/
drwxrwxrwx 1 apc      apc           0 Mar 18 2018 sec/
drwxrwxrwx 1 apc      apc           0 Mar 18 2018 dbg/
drwxrwxrwx 1 apc      apc           0 Mar 18 2018 fwl/
drwxrwxrwx 1 apc      apc           0 Mar 18 2018 rms/
```

Error Message: E000

dns

Access: Super User, Administrator

Description: Configure the manual Domain Name System (DNS) settings.

Parameters:

Option	Argument	Description
-OM	<enable disable>	Override the manual DNS.
-p	<primary DNS server>	Set the primary DNS server.
-s	<secondary DNS server>	Set the secondary DNS server.
-d	<domain name>	Set the domain name.
-n	<domain name IPv6>	Set the domain name IPv6.
-h	<host name>	Set the host name.
-y	<enable disable>	System-hostname sync

Example:

```
apc> dns -h myHostName  
E000: Success
```

Error Message: E000, E102

email**Access:** Super User, Administrator**Description:** Configure email parameters.**Parameters:**

Option	Argument
-g[n]	<enable disable> (Generation)
-t[n]	<To Address>
-o[n]	<long short> (Format)
-l[n]	<Language Code>
-r[n]	<Local recipient custom> (Route)
Custom Route Option	
-f[n]	<From Address>
-s{n}	<SMTP Server>
-p[n]	<Port>
-a[n]	<enable disable> (Authentication)
-u[n]	<User Name>
-w[n]	<Password>
-e[n]	<none ifsupported always implicit> (Encryption)
-c[n]	<enable disable > (Required Certificate)
-i[n]	<Certificate File Name>
n = Email Recipient Number 1, 2, 3, or 4	

Example:

```
apc> email -o2 short
E000: Success
```

Error Message: E000, E102

eventlog

Access: Super User, Administrator, Device User, Read Only User

Description: View the date and time in which the event log was retrieved. View the status of the Rack, and the status of sensors connected to the Rack. View the most recent device events and the date and time they occurred.

Parameters: Use the following keys to navigate the event log:

Key	Description
Esc	Close the event log and return to the CLI.
Enter	Update the log display. Use this command to view events that were recorded after the last time the log was retrieved and displayed.
Spacebar	View the next page of the event log.
B	View the preceding page of the event log. This command is not available at the main page of the event log.
D	Delete the event log. Follow the prompts to confirm or deny the deletion. Deleted events cannot be retrieved.

Example:

```

apc> eventlog
E000: Success
---- Event Log -----
Date: 08/      Time:
30/2018      13:22:-
              26
-----
Date          Time          User          Event
-----
--
08/30/2018   13:17:-      System:       Set Time.
              22
08/30/2018   13:16:-      System:       Configuration change. Date format
              57                    preference.
08/30/2018   13:16:-      System:       Set Date.
              49
08/30/2018   13:16:-      System:       Configuration change. Date format
              35                    preference.
08/30/2018   13:16:-      System:       Set Date.
              08
08/30/2018   13:15:-      System:       Set Time.
              30
08/30/2018   13:15:-      System:       Set Time.
              00
08/30/2018   13:13:-      System:       Set Date.
              58
08/30/2018   13:12:-      System:       Set Date.
              22
08/30/2018   13:12:-      System:       Set Date.
              08
08/30/2018   13:11:-      System:       Set Date.
              41
<ESC>- Exit, <ENTER>- Refresh, <SPACE>- Next, <D>- Delete
    
```

Error Message: E000, E100

exit

See `bye`, `exit`, or `quit`, page 86.

firewall

Access: Super User, Administrator

Description: Establishes a barrier between a trusted, secure internal network and another network.

Parameters:

Option	Argument	Description
-S	<enable disable>	Enable or disable the Firewall.
-f	<file name to activate>	Name of the firewall to activate.
-t	<file name to test> <duration time in minutes>	Name of firewall to test and duration time in minutes.
-fe	No argument. List only	Shows active file errors.
-te	No argument. List only	Shows test file errors.
-c	No argument. List only	Cancel a firewall test.
-r	No argument. List only	Shows active firewall rules.
-l	No argument. List only	Shows firewall activity log.
-Y	No argument.	Skip firewall test prompt.

Example:

```
apc> firewall
E000: Success
Firewall:    disabled
File name:   example.fwl
```

Error Message: E000, E102

format

Access: Super User, Administrator

Description: Format the flash file system. This deletes all configuration data (including network settings), event and data logs, certificates and keys.

NOTE: The user must confirm by entering "YES" when prompted.

Parameters: None.

Example:

```
apc> format
Format FLASH file system
```

```
Warning: This will delete all configuration data,
event and data logs, certs and keys.
```

```
Enter 'YES' to continue or <ENTER> to cancel:
```

Error Message: None.

ftp

Access: Super User, Administrator

Description: Get/set the ftp configuration data.

NOTE: The system will reboot if any configuration is changed.

Parameters:

Option	Argument	Description
-p	<port number> (21 and 5000-32768)	Define the TCP/IP port that the FTP server uses to communicate with the (21 by default). The FTP server uses both the specified port and the port one number lower than the specified port. Valid port numbers are 21 and 5000-32768.
-s	<enable disable>	Configure access to the FTP server.

Example:

```
apc> ftp -p 5001
E000: Success
```

```
apc> ftp
E000: Success
Service:      Enabled
Ftp Port:     5001
```

```
apc> ftp -p 21
E000: Success
```

Error Message: E000, E102

help

Access: Super User, Administrator, Device User, Read Only User

Description: View a list of all the CLI commands available to the user account type. To view help text for a specific command, type the command followed by a question mark.

Parameters: [<command>]

Example 1:

```
apc> ?
System Commands:
-----
For command help: command ?
?          about      alarmcount  boot        bye          cd
cipher     clrrst     console    date        delete       dir
dns        email      eventlog   exit        firewall     format
ftp        help       lang       lastrst     ledblink     logzip
netstat    ntp        ping       portspeed   prompt       pwd
quit       radius     reboot     resetToDef  session      smtp
snmp       snmptrap   snmpv3     system      tcpip        tctpip6
user       userdfilt  web        whoami      xferINI     xferStatus
```

Example 2:

```
apc> help boot
Usage: boot -- Configuraiton Options
boot    [-b <dhcpBootp | dhcp | bootp | manual>] (IPv4 Boot Mode)
        [-c <enable | disable>] (Require DHCPv4 Cookie)
        [-v <vendor class>]
        [-i <client id>]
        [-u <user class>]
```

Error Message: E000, E102

lang

Access: Super User, Administrator, Device User, Read Only User

Description: Displays the language in use.

Parameters: None.

Example:

```

apc> lang
E000: Success
Languages
enUs - English

```

Error Message: E000

lastrst

Access: Super User, Administrator

Description: Last reset reason.

Parameters: None.

Example:

```

apc> lastrst
00 Reset Cleared
E000: Success

```

Error Message: E000, E102

ledblink

Access: Super User, Administrator

Description: Sets the blink rate to the LED on the .

Parameters:

Argument	Description
<time>	Number of minutes to blink the LED

Example:

```

apc> ledblink 1
E000: Success

```

Error Message: E000, E102

logzip

Access: Super User, Administrator

Description: Places large logs into a zip file before sending.

Parameters:

Option	Argument	Description
-m	<email recipient>	Email recipient number (1-4).

Example:

```
apc> logzip -m 1
Generating files
Compressing files into /dbg/debug_ZA1023006009.tar
Emailing log files to email recipient - 1
E000: Success
```

Error Message: E000, E102

netstat

Access: Super User, Administrator

Description: Displays incoming and outgoing network connections.

Parameters: None.

Example:

```
apc> netstat
Current IP Information
Family  mHome  Type    IPAddress                               Status
IPv6    4       auto    FE80::2C0:B7FF:FE51:F304/64            configured
IPv6    0       manual  ::1/128                                  configured
IPv4    0       manual  127.0.0.1/32                             configured
```

Error Message: None.

ntp

Access: Super User, Administrator

Description: Synchronizes the time of the Network Interface to the time of the specified NTP server. The time is defined as Coordinated Universal Time (UTC), formerly Greenwich Mean Time. The timezone must be set correctly using the date command. See date, page 89.

Parameters:

Option	Argument	Description
-OM	<enable disable>	Override the manual settings.
-p	<primary NTP server>	Specify the primary server.
-s	<secondary NTP server>	Specify the secondary server.

Example 1: To enable the override of manual setting, type

```
apc> ntp -OM enable
```

Example 2: To specify the primary NTP server, type

```
apc> ntp -p 150.250.6.10
```

Error Message: E000, E102

ping

Access: Super User, Administrator, Device User

Description: Perform a network 'ping' to any external network device.

Parameters:

Argument	Description
<IP address or DNS name>	Type an IP address with the format xxx.xxx.xxx.xxx, or the DNS name configured by the DNS server.

Example:

```
apc> ping 192.168.1.50
E000: Success
Reply from 192.168.1.50: time (ms) = <10
Reply from 192.168.1.50: time (ms) = <10
Reply from 192.168.1.50: time (ms) = <10
Reply from 192.168.1.50: time (ms) = <10
```

Error Message: E000, E100, E102

portSpeed

Access: Super User, Administrator

Description: Get/set the network port speed.

NOTE: The system will reboot if any configuration is changed.

Parameters:

Option	Argument	Description
-s	<auto 10H 10F 100H 100 F>	Define the communication speed of the Ethernet port. The auto command lets the Ethernet devices negotiate to transmit at the highest possible speed. See for more information about the port speed settings.
H = Half Duplex		10 = 10 Meg Bits
F = Full Duplex		100 = 100 Meg Bits

Example:

```
apc> portspeed
E000: Success
Port Speed: Auto_negotiation
Current Port Speed: 100 Full_Duplex
```

```
apc> portspeed -s 10h
E000: Success
```

```
apc> portspeed
E000: Success
Port Speed: 100 Half_Duplex
Current Port Speed: 100 Half_Duplex
```

```
apc> portspeed -s auto
E000: Success
```

Error Message: E000, E102

prompt**Access:** Super User, Administrator, Device User**Description:** Change the format of the prompt, either short or long.**Parameters:**

Option	Argument	Description
-s	long	The prompt includes the account type of the currently logged-in user.
	short	The default setting. The prompt is four characters long: APC>

Example:

```
apc> prompt -s long
E000: Success
```

```
Administrator@apc> prompt -s short
E000: Success
```

Error Message: E000, E102**pwd****Access:** Super User, Administrator, Device User, Read Only User**Description:** Used to output the path of the current working directory.**Parameters:** None.**Example:**

```
apc> pwd
/
```

```
apc> cd logs
E000: Success
```

```
apc> pwd
/logs
```

Error Message: E000, E102

quit

See `bye`, `exit`, or `quit`, page 86.

radius

Access: Super User, Administrator

Description: View the existing RADIUS settings, enable or disable RADIUS authentication, and configure basic authentication parameters for up to two RADIUS servers.

Additional authentication parameters for RADIUS servers are available in the Web UI of the Rack.

For detailed information about configuring the RADIUS server, see the *Security Handbook*, available at www.apc.com.

Parameters:

Option	Argument	Description
-a	<local radiusLocal radius>	Configure RADIUS authentication: local: RADIUS is disabled. Local authentication is enabled. radiusLocal: RADIUS, then Local Authentication. RADIUS and local authentication are enabled. Authentication is requested from the RADIUS server first. If the RADIUS server fails to respond, local authentication is used. radius: RADIUS is enabled. Local authentication is disabled.
-p1 -p2	<server ip>	The IP address of the primary or secondary RADIUS server.
-o1 -o2	<server port>	The server port of the primary or secondary RADIUS server. NOTE: RADIUS servers use port 1812 by default to authenticate users. The Rack supports ports 1812, 5000 to 32768.
-s1 -s2	<server secret>	The shared secret between the primary or secondary RADIUS server and the Rack.
-t1 -t2	<server timeout>	The time in seconds that the Rack waits for a response from the primary or secondary RADIUS server.

Example 1: To view existing RADIUS settings for the Rack, type `radius` and press Enter.

```

apc> radius
E000: Success
Access:                               Local Only
Primary Server:                        0.0.0.0
Primary Server Port:                   1812
Primary Server Secret:                 <Password Hidden>
Primary Server Timeout:                 5
Secondary Server:                      0.0.0.0
Secondary Server Port:                 1812
Secondary Server Secret:               <Password Hidden>
Secondary Server Timeout:              5
    
```

Example 2: To enable RADIUS and local authentication, type

```
apc> radius -a radiusLocal
E000: Success
```

Example 3: To configure a 10-second timeout for a secondary RADIUS server, type

```
apc> radius -t2 10
E000: Success
```

Error Message: E000, E102

reboot

Access: Super User, Administrator

Description: Restart the NMC interface only. Forces the network device to reboot.

Parameters:

Option	Description
-Y	Skip confirmation prompt (Uppercase Y only).

Example 1:

```
apc> reboot
E000: Success
Reboot Management Interface
Enter 'Y' to continue or <ENTER> to cancel : <user enters `YES`>
Rebooting...
```

Example 2:

```
apc> reboot -Y
E000: Success
Reboot Management Interface
Rebooting...
```

Error Message: E000, E100

resetToDef

Access: Super User, Administrator

Description: Reset all parameters to their default.

Parameters:

Option	Argument	Description
-p	<all keepip>	Reset all configuration changes, including event actions, device settings, and, optionally, TCP/IP configuration settings. all: all configuration data, including the IP address. keepip: all configuration data, except the IP address.

Example: To reset all of the configuration changes except the TCP/IP settings, type

```
apc> resettodef -p keepip
Reset to Defaults Except TCP/IP
Enter 'YES' to continue or <ENTER> to cancel: <user enters 'YES'>
Now initializing system to default values including
all User Names, Passwords.
Please wait...
Please reboot system for changes to take effect!
```

Error Message: E000, E100

session

Access: Super User, Administrator

Description: Records who is logged in (user), the interface, the Address, time, and ID.

Parameters:

Option	Argument	Description
-d	<session ID>	Delete session
-m	<enable disable>	Multi-User Enable
-a	<enable disable>	Remote Authentication Override

Example:

```
apc> session
User      Interface  Address    Logged In Time  ID
-----
apc       Web        x.x.x.x    00:00:08        156
apc       Telnet     x.x.x.x    00:00:02        157
E000: Success
```

Error Message: E000, E102

smtp**Access:** Super User, Administrator**Description:** Internet standard for electronic mail.**Parameters:**

Option	Argument
-f	<From Address>
-s	<SMTP Server>
-p	<Port> NOTE: Port options are 25, 465, 587, and 5000-32768
-a	<enable disable> (Authentication)
-u	<User Name>
-w	<Password>
-e	<none ifavail always implicit> (Encryption)
-c	<enable disable> (Require Certificate)
-i	<Certificate File Name>

Example:

```

apc> smtp
E000: Success
      From:          address@example.com
      Server:        mail.example.com
      Port:          25
      Auth:          disabled
      User:          User
      Password:      <not set>
      Encryption:   none
      Req. Cert:    disabled
      Cert File:    <n/a>

```

Error Message: E000, E102

snmp**Access:** Super User, Administrator**Description:** Enable or disable SNMP 1 or SNMP 3 and configure basic SNMP settings.**Parameters:**

Option	Argument	Description
-c	<Community>	Identify the group of Rack.
-a	<read write writeplus disable>	Set the access level.
-n	<IP or Domain Name>	The host's name or address.
-S	<enable disable>	Enable or disable the respective version of SNMP.

Example:

```
apc> snmp
E000: Success
SNMPv1: enabled
Access Control summary:
Access Control #:          1
Community:                 public
Access Type:               read
Address:                   0.0.0.0

Access Control #:          2
Community:                 private
Access Type:               write+
Address:                   0.0.0.0

Access Control #:          3
Community:                 public2
Access Type:               disabled
Address:                   0.0.0.0

Access Control #:          4
Community:                 private2
Access Type:               disabled
Address:                   0.0.0.0
```

Error Message: E000, E102

snmpv3**Access:** Super User, Administrator**Description:** Enable or disable SNMPv3, and configure basic SNMPv3 parameters.**Parameters:**

Option	Argument	Description
-S	<enable disable>	Enable or disable the respective version of SNMP
-u[n]	<User Name>	User Name
-a[n]	<Auth phrase>	Authentication pass phrase of the user profile.
-c[n]	<Crypt phrase>	Crypt phrase of the user profile.
-ap[n]	<sha md5 none>	Authentication protocol
-pp[n]	<aes des none>	Privacy protocol
-ac[n]	<enable disable>	Access
-au[n]	<User Profile Name>	Access User Profile
-n[n]	<NMS IP>	The host name or IP address
n = access control number (1, 2, 3, or 4)		

Example:

```

apc> snmpv3
E000: Success
SNMPv3 Configuration
    SNMPV3:                disabled

SNMPv3 User Profiles
    Index:                  1
    User Name:              apc snmp profile1
    Authentication:        None
    Encryption:            None

    Index:                  2
    User Name:              apc snmp profile2
    Authentication:        None
    Encryption:            None

    Index:                  3
    User Name:              apc snmp profile3
    Authentication:        None
    Encryption:            None

    Index:                  4
    User Name:              apc snmp profile4
    Authentication:        None
    Encryption:            None

SNMPv3 Access Control

```

Index: 1
User Name: apc snmp profile1
Access: disabled
NMS IP/Host Name: 0.0.0.0

Index: 2
User Name: apc snmp profile2
Access: disabled
NMS IP/Host Name: 0.0.0.0

Index: 3
User Name: apc snmp profile3
Access: disabled
NMS IP/Host Name: 0.0.0.0

Index: 4
User Name: apc snmp profile4
Access: disabled
NMS IP/Host Name: 0.0.0.0

Error Message: E000, E102

snmptrap**Access:** Super User, Administrator**Description:** Enable or disable SNMP trap generation.**Parameters:**

Option	Argument
-c{n}	<Community>
-r{n}	<Receiver NMS IP>
-l{n}	<Language> [language code]
-t{n}	<Trap Type> [snmpV1 snmpV3]
-g{n}	<Generation> [enable disable]
-a{n}	<Auth Trap> [enable disable]
-u{n}	<profile1 profile2 profile3 profile4> (User Name)
n = Trap receiver number = 1, 2, 3, 4, 5 or 6	

Example:

```
apc> snmptrap
E000: Success
```

```
SNMP Trap
Configuration
```

```
Index:          1
Receiver IP:    x.x.x.x
Community:     public
Trap Type:     SNMPV1
Generation:    disabled
Auth Traps:    enabled
User Name:     apc snmp profile1
Language:      enUs - English
```

Error Message: E000, E102

system

Access: Super User, Administrator

Description: View and set the system identification, contact, and location. View up time, date and time, the logged-on user, and the high-level system status P, N, A.

Parameters:

Option	Argument	Description
-n	<system-name>	Define the device name, the name of the person responsible for the device, and the physical location of the device. NOTE: If a value is defined with more than one word, the value must be enclosed in quotation marks. NOTE: These values are also used by StruxureWare Data Center Expert and the Rack's SNMP agent.
-c	<system-contact>	
-l	<system-location>	
-m	<system-message>	When defined, a custom message will appear on the log on screen for all users.
-s	<enable disable>] (system-hostname sync)	Allow the host name to be synchronized with the system name so both fields automatically contain the same value. NOTE: When enabling this feature, the system name identifier can no longer contain a space character (since it will be synchronized to the host name field).

Example 1:

```
apc> system -l "Test Lab"
E000: Success
```

Example 2:

```
apc> system -n
E000: Success
Name:
```

Error Message: E000, E102

tcpip**Access:** Super User, Administrator**Description:** View and manually configure these network settings for the Rack.**Parameters:**

Option	Argument	Description
-i	<IP address>	Type the IP address of the Rack using the format xxx.xxx.xxx.xxx
-s	<subnet mask>	Type the subnet mask for the Rack.
-g	<gateway>	Type the IP address of the default gateway. Do not use the loopback address (127.0.0.1) as the default gateway.
-d	<domain name>	Type the DNS name configured by the DNS server.
-h	<host name>	Type the host name that the Rack will use.
-S	<enable disable>	Enable or disable IPv4.

Example 1: To view the network settings of the Rack, type `tcpip` and press Enter.

```

apc> tcpip
E000: Success

Active IPv4 Settings
-----
Active IPv4 Address:      10.150.60.232
Active IPv4 Subnet Mask: 255.255.255.0
Active IPv4 Gateway:     10.150.60.1

Manually Configured IPv4 Settings
-----
IPv4:                     enabled
Manual Settings:         disabled
IPv4 Address:             0.0.0.0
Subnet Mask:              0.0.0.0
Gateway:                  0.0.0.0
MAC Address:              00 C0 B2 32 D7 7A
Domain Name:              example.com
Host Name:                 HostName

```

Example 2: To view the IP address of the Rack, type

```

apc> tcpip -i
E000: Success
IP Address:                192.168.1.50

```

Example 3: To manually configure an IP address of 150.250.6.10 for the Rack, type

```

apc> tcpip -i 150.250.6.10
E000: Success
Reboot required for change to take effect

```

Error Message: E000, E102**tcpip6****Access:** Super User, Administrator

Description: Enable IPv6 and view and manually configure these network settings for the Rack.

Parameters:

Option	Argument	Description
-s	<enable disable>	Enable or disable IPv6.
-man	<enable disable>	Enable manual addressing for the IPv6 address of the Rack.
-auto	<enable disable>	Enable the Rack to automatically configure the IPv6 address.
-i	<IPv6 address>	Set the IPv6 address of the Rack.
-g	<IPv6 gateway>	Set the IPv6 address of the default gateway. Do not use the loopback address (::1) as the default gateway.
-d6	<router statefull stateless never>	Set the DHCPv6 mode, with parameters of router controlled, statefull (for address and other information, they maintain their status), stateless (for information other than address, the status is not maintained), never.

Example: To view the network settings of the Rack, type `tcpip6` and press Enter.

```
apc> tcpip6
E000: Success

IPv6:                enabled
Manual Settings:    disabled

IPv6 Address:        ::/64
MAC Address:         00 C0 B7 92 F2 71
Gateway:             ::
IPv6 Manual Address: disabled
IPv6 Autoconfiguration: enabled
DHCPv6 Mode:        router controlled
```

Error Message: E000, E102

user**Access:** Super User, Administrator**Description:** Configure the user name, password, and inactivity timeout for configured users. It is not possible to edit a user name; it must be deleted and then a new user created.**Parameters:**

Option	Argument	Description
-n	<user>	Specify these options for a user.
-pw	<user password>	
-pe	<user permission>	
-d	<user description>	
-e	<enable disable>	Enable overall access.
-st	<session timeout>	Specify how long a session lasts waits before logging off a user when the keyboard is idle.
-sr	<enable disable>	Bypass RADIUS by using the serial console (CLI) connection, also known as Serial Remote Authentication Override
-el	<enable disable>	Indicate the Event Log color coding.
-lf	<tab csv>	Indicate the format for exporting a log file.
-ts	<us metric>	Indicate the temperature scale, fahrenheit or celsius.
-df	<mm/dd/yyyy dd. mm.yyyy mmm-dd- yy dd-mmm-yy yyyy-mm-dd>	Specify a date format.
-lg	<language code (e. g. enUs)>	Specify a user language.
-del	<user name>	Delete a user.
-l	no argument	Display the current user list.

Example:

```

apc> user -n apc
E000: Success
Access: Enabled
User Name: apc
Password: <hidden>
User Permission: Super User
User Description: User Description
Session Timeout: 3 minutes
Serial Remote Authentication Override: Disabled
Event Log Color Coding: Enabled
Export Log Format: Tab
Temperature Scale: Metric
Date Format: mm/dd/yyyy
Language: English (enUs)

```

Error Message: E000, E102

userdfit

Access: Super User, Administrator

Description: Complimentary function to “user” establishing default user preferences. There are two main features for the default user settings:

- Determine default values when the Super User or Administrator-level account creates a new user. These values can be changed before the settings are applied to the system.
- For remote users (user accounts not stored in the system that are remotely authenticated, such as RADIUS), these values are used when a value is not provided by the authenticating server. For example, if a RADIUS server does not provide the user with a temperature preference, the value defined in this section will be used.

Parameters:

Option	Argument	Description
-e	<enable disable> (Enable)	By default, user will be enabled or disabled upon creation. Remove (Enable) from the end
-pe	<Administrator Device Read-Only Network-only> (user permission)	Specify the user's permission level and account type.
-d	<user description>	Provide a user description.
-st	<session timeout> minute(s)	Provide a default session timeout.
-bl	<bad login attempts>	Number of incorrect login attempts a user has before the system disables their account. Upon reaching this limit, a message is displayed informing the user the account has been locked. The Super User or an Administrator-level account is needed to re-enable the account to allow the user to log back in. NOTE: A Super User account cannot be locked out, but can be manually disabled if necessary.
-el	<enable disable> (Event Log Color Coding)	Enable or disable event log color coding.
-lf	<tab csv> (Export Log Format)	Specify the log export format, tab or CSV.
-ts	<us metrics> (Temperature Scale)	Specify the user's temperature scale. This setting is also used by the system when a user preference is not available (for example, email notifications).
-df	<mm/dd/yyyy dd. mm.yyyy mmm-dd- yy dd-mmm-yy yyyy-mm-dd> (Date Format)	Specify the user's preferred date format.
-lg	<language code (enUs, etc)>	User language
-sp	<enable disable>	Strong password
-pp	<interval in days>	Required password change interval

Example:

```
apc> userdflt
E000: Success
Access: Disabled
User Permission: Administrator
User Description: User Description
Session Timeout: 3 minutes
Bad Login Attempts: 0
Event Log Color Coding: Enabled
Export Log Format: Tab
Temperature Scale: Metric
Date Format: mm/dd/yyyy
Language: English (enUs)
Strong Passwords: Disabled
Require Password Change: 0 day(s) (Disabled)
```

Error Message: E000, E102

web

Access: Super User, Administrator

Description: Enable access to the web interface using HTTP or HTTPS.

For additional security, the port setting for HTTP and HTTPS can be changed to any unused port from 5000 to 32768. Users must then use a colon (:) in the address field of the browser to specify the port number. For example, for a port number of 5000 and an IP address of 152.214.12.114, type

`http://152.214.12.114:5000`

Parameters:

Option	Argument	Description
-h	<enable disable>	Enable or disable access to the user interface for HTTP.
-s	<enable disable>	Enable or disable access to the user interface for HTTPS. When HTTPS is enabled, data is encrypted during transmission and authenticated by digital certificate.
-ph	<http port #>	Specify the TCP/IP port used by HTTP to communicate with the (80 by default). The other available range is 5000-32768.
-ps	<https port #>	Specify the TCP/IP port used by HTTPS to communicate with the (443 by default). The other available range is 5000-32768.
-mp	<minimum protocol>	Specify the minimum HTTPS protocol to use. Options are SSL3.0 TLS1.0 TLS1.1 TLS1.2
-lsp	<enable disable>	Enable or disable the limited status page.
-lsd	<enable disable>	Enable or disable the limited status page as the default page.

Example 1: To prevent all access to the Web UI, type

```
apc> web -h disable -s disable
```

Example 2: To define the TCP/IP port used by HTTP, type

```
apc> web
E000: Success

tTp:                enabled
Https:              disabled
Http Port:          80
Https Port:         443
Minimum Protocol:   TLS1.1

apc> web -ph 80
E000: Success
```

Error Message: E000, E102

whoami

Access: Super User, Administrator, Device User, Read Only User

Description: Provides login information on the current user.

Parameters: None.

Example:

```

apc> whoami
E000: Success
admin

```

Error Message: None.

xferINI

Access: Super User, Administrator

Description: Use XMODEM to upload an INI file while accessing the CLI through a serial connection. After the upload completes:

- If there are any system or network changes, the CLI restarts and the user must log on again.
- If you selected a baud rate for the file transfer that is not the same as the default baud rate for the Rack, you must reset the baud rate to the default to reestablish communication with the Rack.

Parameters:None.

Example:

```

apc> xferINI
Enter 'YES' to continue or <ENTER> to cancel : <user enters 'YES'>
----- File Transfer Baud Rate -----
1-2400
2-9600
3-19200
4-38400
> <user enters baudrate selection>
Transferring at current baud rate (9600) , press <ENTER>...
<user presses <ENTER>>
Start XMODEM-CRC Transfer Now!
CC
<user starts sending INI>
150 bytes have successfully been transmitted.

```

Error Message: None.

xferStatus

Access: Super User, Administrator

Description: View the result of the last file transfer. See for descriptions of the transfer result codes.

Parameters: None.

Example:

```
apc> xferStatus
E000: Success
Result of last file transfer: Failure unknown
```

Error Message: E000

Access a Configured Unit

Overview

After the unit is running on the related network, the configured cooling unit can be accessed through the following interfaces:

- Web interface
- Telnet/SSH
- Simple Network Management Protocol (SNMP)
- FTP/SCP
- Modbus



For more information on the interfaces, see the *Online Guide*.

Web Interface

Use Microsoft Internet Explorer® 7.x or higher (on Windows operating systems only), or Mozilla® Firefox® 3.0.6 or higher (on all operating systems) to access the cooling unit through its Web interface. Other commonly available browsers also may work but have not been fully tested by Schneider Electric.

Either of the following protocols can be used when using a Web browser to configure display interface options or to view the event log:

- The HTTP protocol (disabled by default), which provides authentication by user name and password but no encryption.
- The HTTPS protocol, which provides extra security through Secure Sockets Layer (SSL), encrypts user names, passwords, and data being transmitted, and authenticates the Network Management Card by means of digital certificates.

To access the Web interface and configure the security of the cooling unit in use on the network,

1. Enter the IP address or DNS name of the cooling unit into a Web browser.
2. Enter the user name and password (both are `apc` by default).
3. To enable or disable the HTTP or HTTPS protocols, use **Main > Configuration > Network**.



For more information on selecting and configuring network security, see the UPS Network Management Card Security Handbook, available on www.schneider-electric.com: search for “UPS Network Management Cards.”

Telnet and SSH

The control console can be accessed through Telnet and/or Secure SHell (SSH), depending on which is enabled. To enable these access methods from the Web UI, select **Configuration > Network > Console > Access**. By default, Telnet is disabled. Telnet and SSH can be enabled simultaneously.

Telnet for Basic Access

Telnet provides the basic security of authentication by user name and password, but not the high-security benefits of encryption. To use Telnet to access the Network Management Card control console from any computer on the same network,

1. Enable Telnet via Web UI.
2. At a command prompt, use the following command line, and press **ENTER**:

```
telnet address
```

As *address*, use the Network Management Card IP address or DNS name (if configured).

3. Enter the user name and password (by default, `apc` and `apc` for an Administrator, or `device` and `apc` for a Device User).

SSH for High-Security Access

If the high security of SSL is used for the Web interface, use Secure SHell (SSH) for access to the CLI. SSH encrypts user names, passwords, and transmitted data.

The interface, user accounts, and user access rights are the same whether the CLI is accessed through SSH or Telnet, but to use SSH, this must first be configured and have an SSH client program installed on the computer in use.



See the *Online Guide* for more information on configuring and using SSH.

Simple Network Management Protocol (SNMP)

SNMPv1 Only

After adding the latest version of PowerNet® MIB to a standard SNMP MIB browser, that browser can be used to access the device. All user names, passwords, and community names for SNMP are transferred over the network as plain text.

SNMPv3 Only

For SNMP GETs, SETs, and trap receivers, SNMPv3 uses a system of user profiles to identify users. An SNMPv3 user must have a user profile assigned in the MIB software program to perform GETs and SETs, browse the MIB, and receive traps. The default settings are **no authentication** and **no privacy**.

NOTE: To use SNMPv3, it is necessary to have an MIB program that supports SNMPv3, and SNMPv3 must be configured correctly in the Network Management Card.

The device supports SHA or MD5 authentication and V or DES encryption.

SNMPv1 and SNMPv3

To use StruxureWare Data Center Expert to manage the device on the public network of StruxureWare system, a SNMPv1 must be enabled in the unit interface. Read access allows devices to receive traps from the unit. Write access is required while setting the device as a trap receiver.

To enable or disable SNMP access, the user must be an Administrator. Select **Administration > Network** and select the access option under SNMPv1 or SNMPv3.

FTP/SCP

FTP (disabled by default) or Secure CoPy (SCP) can be used to transfer downloaded firmware to the Network Management Card or to access a copy of the device event or data logs. SCP provides the higher security of encrypted data transmission and is activated automatically when SSH is enabled. FTP and SCP can be enabled simultaneously.

To access the Network Management Card through FTP or SCP, the default user name and password are `apc` and `apc` for an Administrator, or `device` and `apc` for a Device User. In the command line, use the IP address of the unit.

NOTE: If SSL and SSH are enabled for their high-security authentication and encryption, disable FTP. To disable FTP, the user must be an Administrator. Go to **Main > Configuration > Network** to enable FTP.



In the *User Manual*, see the following sections:

- To transfer firmware, see “File Transfers.”
- To retrieve a copy of the event or data log, see “How to Use FTP or SCP to Retrieve Log Files.”

Modbus

Modbus allows for viewing the Network Management Card through the interface of the building management system in use.

The Modbus RTU interface supports 2-wire RS-485, 4-wire RS-485, plus ground MODBUS TCP.

NOTE: Modbus can be configured to run at either 9600 or 19200 bps. It is already configured for 8 data bits, no parity, and 1 stop bit: parity is changeable but data bits and stop bits are not.



To access the Modbus Register Map, go to the Schneider Electric website, www.schneider-electric.com, and search for “Modbus Register Map.”

Recover From a Lost Password

Use a local computer (a computer that connects to the Network Management Card through the serial port) to access the command line interface (CLI).

1. Select a serial port at the local computer, and disable any service that uses that port.
2. Connect the Schneider Electric serial cable (part number 940-0299) to the selected port on the computer and to the serial port on the front of the display.
3. Run a terminal program (such as HyperTerminal®) and configure the selected port:
 - 9600 bps
 - 8 data bits
 - No parity
 - 1 stop bit
 - No flow control
4. Press the **RESET** button on the front of the display, immediately press **ENTER** on the computer keyboard, repeatedly if necessary, to display the **User Name** prompt.

NOTE: If the **ENTER** key is not pressed before five seconds elapse, press the **RESET** button.

If the **User Name** prompt is not displayed, verify the following:

- The serial port is not in use by another application.
 - The terminal settings are correct as specified in step 3.
 - The correct cable is being used as specified in step 2.
5. Press the **RESET** button on the front of the display. The Status LED will alternately flash orange and green. Immediately press the **RESET** button on the front of the display a second time while the LED is flashing to temporarily reset the user name and password to their defaults.
 6. Press **ENTER** on the computer keyboard as many times as necessary to re-display the **User Name** prompt, then use the default, **apc**, for the user name and password. (If the user take longer than 30 seconds to log on after the **User Name** prompt is re-displayed, step 5 and log on must be repeated.)
 7. At the command line interface, use the following commands to change the password setting, which has been reset to **apc**:

```
user -n <user name> -pw <user password>
```

For example, to change the Super User password to **XYZ**, type

```
user -n apc -pw XYZ
```

8. Type **quit** or **exit** to log off, reconnect any serial cable which has been previously disconnected, and restart any service disabled.

Updating the Firmware

A software update includes latest software features, performance improvements and bug fixes.

Updating here means placing the module files on the unit, without requiring any installation procedure. Check regularly on www.schneider-electric.com for any new software updates.

NOTE: Select the required language pack to obtain the display interface in a language other than English (except the *Service Menu*, which is available in English only).

Update Display Firmware

Using a USB Drive to Transfer and Update Files

Update Display Interface Firmware

1. Insert a USB drive into an available port on the PC and verify that the drive is formatted as a FAT32 file system.
2. Create a folder named **apcfirm** on the USB drive.
3. Acquire the firmware files from the local support team or the Schneider Electric Web site.
4. Unzip and extract the files to the **apcfirm** folder.
 - Operating system (*_aos_*.bin)
 - Boot monitor (*_bootmon_*.bin)
 - Application (*_RD3xx_*.bin)
5. Use a text editor, like Notepad, to create a file named upload.rcf.
6. List the filename for each firmware module in the order to be transferred. An example is shown below.

IMPORTANT: The files must be listed in the correct order in the upload.rcf file.

- The BM (bootmon) file must be listed first: BM=apc_hw06_bootmon_105.bin
- The AOS (operating system) file must be listed second: AOS=apc_hw06_aos_609.bin
- The APP (application) must be listed third: APP=apc_hw06_rd3xx4i_*.bin

NOTE: * in the APP file name is the revision number and will change with each release.

7. Save the upload.rcf file in the **apcfirm** folder.

Your **apcfirm** folder should look similar to the example folder shown here:

Name	Date modified	Type	Size
apc_hw06_aos_646.bin	3/16/2017 3:55 PM	BIN File	3,058 KB
apc_hw06_bootmon_108.bin	3/16/2017 3:55 PM	BIN File	256 KB
apc_hw06_unflirtsa_600g.bin	4/20/2017 4:41 PM	BIN File	2,454 KB
upload.rcf	3/17/2017 7:16 AM	RCF File	1 KB

8. Insert the USB drive into the USB-A port on the display interface.
A confirmation message appears on the display interface.

9. Press the **Display Reset** button to reset the display interface.

The display interface resets and transfers files. The display will resume operation when transfer is complete.

NOTE: The touch screen will be disabled during the transfer process. There is no disruption of unit operation during the file transfer process.

10. Remove the USB drive when the file transfer is complete.
11. Check the firmware version on the touch screen display interface on the **Main > About > Display** screen.
12. To update the firmware on additional units, repeat from step 8.

Update Controller Firmware

Before starting the transfer, make sure the USB drive is formatted in FAT32.

Path: Main > Configuration > Service > USB > Firmware Download

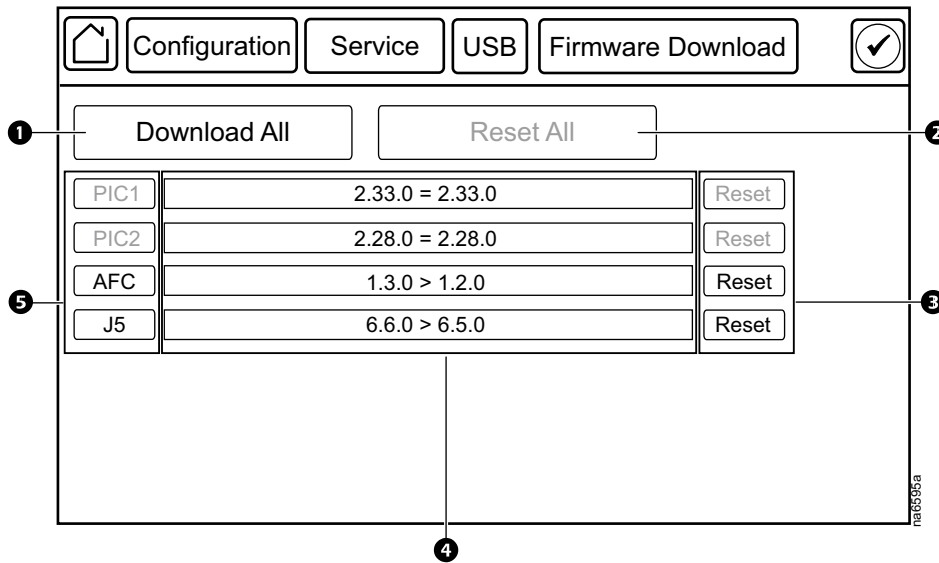

Item	Description	Function
1	Download All	Downloads all available firmware updates.
2	Reset All	Resets all controllers that have had firmware updates. This button will appear gray if no controllers need to be reset.
3	Reset	Resets the corresponding controllers individually. These buttons will appear gray if the controller cannot be reset or is not present.
4	Firmware revision	Displays the firmware revision on the USB drive on the left side of the operation symbol and the current firmware revision on the controller on the right side of the operation symbol. NOTE: Make sure to check the revision numbers: the revision on the drive may not be a newer release.
	= symbol	An equals symbol denotes that the firmware revisions are the same.
	> symbol	A greater than symbol denotes that the current firmware can be changed to the firmware revision on the USB drive.
	Device Not Present	The controller is not present in the unit.
5	Controllers	Downloads the firmware for the specific controller. These buttons will appear gray if the controller firmware cannot be changed or the controller is not present.
	PIC1	PIC1
	PIC2	PIC2
	AFC	Active Flow Controller
	J5	Unit controller

1. Download the firmware upgrade files and unzip them.
2. Create a folder named **fw** on the USB flash drive.
3. Place the extracted module files in the **fw** directory.
4. Use a text editor to create a file named fw.rcf. (The file extension must be .rcf, not .txt for example.)

5. In fw.rcf, add a line for each firmware module that needs to be updated. The following are examples of formatting for the file.

NOTE: Make sure the j5.cbp file remains in directory: the J5 controller may download the firmware on its own if there is no valid firmware or the personality jumpers do not match the current loaded firmware.

```
PIC1 = pic1-2.33.0.cbp
```

```
PIC2 = pic2-2.28.0.cbp
```

```
AFC = AFC-1.11.0.cbp
```

```
J5 = J5-1.0.3.cbp
```

6. Place fw.rcf in the **fw** folder on the USB drive.
7. Insert the USB drive into the USB port on the display interface.
8. On the display interface, navigate to **Main > Configuration > Service > USB > Firmware Download**.
9. Select the firmware to download for the controllers individually or for all devices.
10. After downloading the firmware, reset the controllers individually or reset all.
11. Check that the update was completed successfully using the procedures in Verify Updates, page 127.

Verify Updates

Verify Success of the Transfer

To verify whether a firmware upgrade succeeded, use the xferStatus command in the command line interface to view the last transfer result. Alternatively, it is possible to use an SNMP GET to receive the **mfiletransferStatusLastTransferResult** OID.

NOTE: This is only valid for checking the success of the touch screen firmware update.

Last Transfer Result Codes

Possible transfer errors include the TFTP or FTP server not being found, or the server refusing access, the server not finding or not recognizing the transfer file, or a corrupt transfer file.

Verify Version Numbers of Installed Firmware

Use the display interface or the Web user interface to verify the versions of the upgraded firmware modules. It is also possible to use an SNMP GET to the MIB II sysDescr OID. In the command line interface, use the **About** command.

Service Menu

⚠ WARNING

HAZARD TO EQUIPMENT OR PERSONNEL

All work must be performed by Schneider Electric qualified and trained personnel.

Failure to follow these instructions can result in death, serious injury, or equipment damage.

The **Service** menus contain settings related to the operation of the unit that should only be changed by qualified personnel.

Service Menu Access

The **Service** menus are only accessible to service personnel. If you need to access the **Service** menus, you will need to contact technical support with the code displayed in the message window. After receiving a service code from technical support, enter the code in the appropriate window on the display.

Unit Configuration

Path: Main > Configuration > Service > Unit

NOTE: All changes to settings must be performed by qualified personnel.

- **Number of Evaporator Fan Power Supplies:** Set the number of fan power supplies installed in the electrical box. (1 or 2)
- **Evap Fan PS Calibration:** An evaporator fan power supply needs to be calibrated if a new fan power supply has been added to the unit or if a fan power supply has been replaced. Select **Start** and press **OK** to start calibration.
- **Evap Fan PS Calibration: In progress** is displayed if the fan power supply is being calibrated; **Finished** is displayed when calibration is complete.
- **Evap PS 1 Cal Factor:** This calibration factor is a reading from the power supply when it is off: a base number for zero amps. A normal reading is 2048 ±10.
- **Evap PS 2 Cal Factor:** This calibration factor is a reading from the power supply when it is off: a base number for zero amps. A normal reading is 2048 ±10.
- **Air Filter Type:** Select whether the air filters are **Standard** or **High Efficiency**.
- **Maximum Fan Speed:** Set the maximum fan speed percentage allowed for the evaporator fans. (30.0–100.0% for one power supply, 30.0–130.0% for two power supplies)
- **Minimum Fan Speed:** Set the minimum fan speed percentage allowed for the evaporator fans. (20.0–100.0%)
- **Voltage:** Select the voltage of the unit.
 - **Not Configured**
 - **100-120v**
 - **200-240v**
- **Power Feed Type:** Select whether the power feed is a **Single** or **Dual** power feed.

- **Condensate Drain Type:** Select the type of condensate drain used by the unit. (**Gravity** or **Pump**)
- **Smoke-Fire Sensor:** Select **Yes** if the sensor is present.
- **Humidity Sensor Present:** Select **Yes** if the sensor is present.
- **Shutdown Input Present:** Select **Yes** if the shutdown input is present.
- **Shutdown Input State:** Displays the normal state of the shutdown input. (**Open** or **Closed**)
- **Number of Rack Inlet Temp Sensors in Unit:** Set the number of rack inlet air temperature sensors connected to the unit. (0–4)
- **Number of Leak Detectors in Unit:** Set the number of leak sensors connected to the unit. (0–4)
- **EEV Position:** The current position in percentage of the EEV.
- **EEV Opening at Startup:** Enter the starting position of the EEV for the compressor.
- **EEV Mini Pos:** Limits the EEV opening position when the superheat control is active. (%)
- **EXV Type:** Select whether the electronic expansion valve is a **Carel** valve or a **Sporlan** valve.
- **Humidifier Control:** Enable (**Yes**) or disable (**No**) humidification.
NOTE: For ACRD301P and ACRD301H units only.
- **Dehumidification Control:** Enable (**Yes**) or disable (**No**) dehumidification.
NOTE: For ACRD301P and ACRD301H units only.
- **Reheat:** Enable (**Yes**) or disable (**No**) reheating.
NOTE: For ACRD301P and ACRD301R units only.
- **Heat Assist Enable:** Enable (**Yes**) or disable (**No**) heat assistance when the unit is grouped.
NOTE: For ACRD301P and ACRD301R units only.
- **Heater Max Output:** The maximum output percentage for the heater. (0-100%)
NOTE: For ACRD301P and ACRD301R units only.
- **Reheat Gain 'P':** The reheat control proportional coefficient.
NOTE: For ACRD301P and ACRD301R units only.
- **Superheat Recovery:** Select **Yes** to enable the superheat recovery control. Select **No** to disable superheat recovery control. When disabled, this function will be available only once when the compressor is started.
- **Superheat Recovery Timeout:** Enter the time period during which the superheat recovery function is available after the compressor is started. (5–60 minutes)
- **EEV Sync Control:** Enable (**Yes**) or disable (**No**) the EEV synchronization process after the time period entered for **EEV Sync Control**.
- **EEV Sync Control:** EEV synchronization time period. (24–720 hours) data dictionary says 720
- **RH By PwrLn2:** Enable or disable features relating to the humidifier and heater on the secondary power supply.

Containment Systems

Path: Main > Configuration > Service > Containment Systems

- **Number of Active Flow Controllers:** Set the number of Active Flow Controller units in the group. (0–5)

- **Active Flow Control Lamp Test:** When set to **On**, the Active Flow Controller (s) LEDs will cycle through a red, green, and blue illumination pattern.
- **Active Flow Control Bias:** This setting is used to change the bias of the controller by adjusting the contained aisle pressure threshold. **Zero** is the default setting. Only qualified service personnel can make changes to these settings.
 - Hot Aisle Containment (HACS)
 - If the cooling units seem to be under-cooling, select **Negative** or **Slightly Negative** to adjust the aisle pressure for additional cooling.
 - If the cooling units seem to be over-cooling, select **Positive** or **Slightly Positive** to adjust the aisle pressure for less cooling.
 - Cold Aisle Containment (CACS)
 - If the cooling units seem to be under-cooling, select **Positive** or **Slightly Positive** to adjust the aisle pressure for additional cooling.
 - If the cooling units seem to be over-cooling, select **Negative** or **Slightly Negative** to adjust the aisle pressure for less cooling.

Setting	Blue LED—HACS Red LED—CACS	Setpoint Green LED	Red LED—HACS Blue LED—CACS
Positive	< -0.008 in. ±3%	0.004 ±0.0004 in.	> 0.016 in. ±3%
Slightly Positive	< -0.010 in. ±3%	0.002 ±0.0004 in.	> 0.014 in. ±3%
Zero	< -0.012 in. ±3%	0.000 ±0.0004 in.	> 0.012 in. ±3%
Slightly Negative	< -0.014 in. ±3%	-0.002 ±0.0004 in.	> 0.010 in. ±3%
Negative	< -0.016 in. ±3%	-0.004 ±0.0004 in.	> 0.008 in. ±3%

Run Hours and Service Intervals

Path: Main > Configuration > Service > Run Hours

Each component interval setting has an alarm. If set to **Enable**, the annunciator will sound when the service interval for the component has elapsed. The alarms are reset by selecting the check box for the **Reset XXX Service Alarm** for each component and pressing **OK**. Enable service interval alarms and set the number of weeks to service each component in the **XXX Alarm Interval** fields. The run hours counter for the service intervals can be reset or adjusted by qualified personnel after a component has been serviced. The following components can have service intervals configured:

NOTE: Service alarms for the unit and for the air filters are enabled by default. Other alarms must be enabled after startup.

NOTE: Visible alarms will vary depending upon the unit configuration.

- Unit
- Air Filter
- Compressor
- Condenser Fan
- Condensate Pump
- Fan 1
- Fan 2
- Fan 3
- Fan 4
- Fan 5
- Fan 6
- Fan 7
- Fan 8
- Humidifier
- Heater 1
- Heater 2

Compressor Settings

Path: Main > Configuration > Service > Compressor Drive

- **Compressor Speed:** Displays the current speed of the compressor. (Hz)
- **Maximum Compressor Speed:** Enter the maximum speed allowed for the compressor. (60.0–100.0 Hz)
- **Minimum Compressor Speed:** Enter the minimum speed allowed for the compressor. (15.0–60.0 Hz)

NOTE:

1. 20 Hz is suggested when unit is equipped with a flooded receiver kit.
 2. 20 Hz is suggested when a flooded receiver kit is not used and the ambient temperature is higher than 0°C (32°F).
 3. 40 Hz is suggested for all other scenarios.
- **Startup Compressor Speed:** Enter the target speed of the compressor (Hz) when it is first turned on. The target speed is valid until the evaporating temperature exceeds 0°C (32°F). After that, the compressor is controlled by the supply temperature PID. (15–100 Hz)

- **Maximum Compressor Restarts:** Enter how many compressor restarts are allowed within 30 minutes after a compressor trips. The variable frequency drive (VFD) will shut down the compressor if the number of restarts exceeds this value within 30 minutes. (1–20)
- **Enable Envelope Management:** Select whether or not envelope management is enabled.



See Envelope Management, page 51.

- **Compressor Envelope Start Offset:** The environmental action offset. This is the temperature offset at which the controller will start applying the compressor envelope management process. (2.8–5.6°C (6.2–12.3°F))
- **Heat Sink Temperature:** Displays the compressor heat sink temperature. (°C (°F))
- **Current:** Displays the compressor current draw. (A)
- **Compressor Power:** The compressor power consumption. (kW)
- **Alarm Status:** The compressor alarm word used for diagnostics.
- **Warning Status:** The compressor warning word used for diagnostics.
- **Software Version:** The software version of the compressor controller.
- **Serial Number:** The serial number of the compressor
- **Software ID:** The compressor driver software ID.

Oil Return Management

Path: Main > Configuration > Service > Oil Return Management

NOTE: All changes to settings must be performed by qualified personnel.

- **Oil Return Management:** Select **Yes** to enable oil return management. This increases the speed for short periods (**Boost Duration**) when the speed is too low (**Low Speed Limit**) to ensure sufficient quantities of oil in the compressor crankcase.
- **Boost Duration:** The length of time for which the compressor speed will be increased to the **Boost Speed**. (60–300 s)
- **Boost Speed:** The speed to which the compressor will be boosted during the **Boost Duration**. (80–200 Hz)
- **Low Speed Running Time:** When oil return management is enabled and the compressor speed is less than the **Low Speed Limit** for this entered length of time, the VFD boosts the compressor speed to the **Boost Speed** for the length of time entered in **Boost Duration**. (1–1400 minutes)
- **Low Speed Limit:** The compressor speed at which **Oil Return Management** will be activated. (80–200 Hz)

PID Settings

NOTICE

DAMAGE TO EQUIPMENT

This procedure is to be performed by Schneider Electric qualified personnel only. Improperly set PID controls could result in equipment damage.

Failure to follow these instructions can result in equipment damage.

Path: Main > Configuration > Service > PIDs

The Proportional plus Integral plus Derivative (PID) loops control the output of the fans and other components.

- **Superheat Control:** Displays whether the PID algorithm for superheat is running (**Run**) or not (**Stop**).
- **Superheat Setpoint:** Set the target value for the temperature difference for refrigerant entering and leaving the coil. (4.4–22.2Δ°C (8.0–40.0Δ°F))
- **Superheat Gain (P):** When the compressor is started, the superheat controller will use this proportional gain for the period of time entered for **Time** during the startup phase. Once the unit is stable, the standard PID gains will resume.
- **Time:** When the compressor is started, during this time of period, the superheat controller will use a special proportional gain. (0-120 minutes)
- **Superheat PID Gain:** The proportional multiplier (gain) for the temperature sensors installed on the inlet and outlet of the cooling coil. The proportional multiplier adjusts for the difference (error) between the measured value and the setpoint.
- **Superheat PID Integral:** The integral multiplier (reset rate) for the temperature sensors installed on the inlet and outlet of the cooling coil. The integral multiplier adjusts for error measurement and the amount of time that the error has existed. The integral multiplier adds to or subtracts from the output in small increments to correct for the offset error caused by the proportional contribution.
- **Superheat PID Derivative:** The derivative multiplier (derivative) for the temperature sensors installed on the inlet and outlet of the cooling coil. The derivative multiplier adjusts the output for rapid changes in the error, correcting for the rate of change of the error over time.
- **Superheat PID Reset:** Select **Yes** to reset the superheat setpoint PID values to factory default settings.
- **Airflow Control:** Displays whether the PID algorithm for airflow control is running (**Run**) or not (**Stop**).

- **Active Flow Control Bias:** This setting is used to change the bias of the controller by adjusting the contained aisle pressure threshold. **Zero** is the default setting. Only qualified service personnel can make changes to these settings.
 - Hot Aisle Containment (HACS)
 - If the cooling units seem to be under-cooling, select **Negative** or **Slightly Negative** to adjust the aisle pressure for additional cooling.
 - If the cooling units seem to be over-cooling, select **Positive** or **Slightly Positive** to adjust the aisle pressure for less cooling.
 - Cold Aisle Containment (CACs)
 - If the cooling units seem to be under-cooling, select **Positive** or **Slightly Positive** to adjust the aisle pressure for additional cooling.
 - If the cooling units seem to be over-cooling, select **Negative** or **Slightly Negative** to adjust the aisle pressure for less cooling.

Setting	Blue LED—HACS Red LED—CACs	Setpoint Green LED	Red LED—HACS Blue LED—CACs
Positive	< -0.008 in. ±3%	0.004 ±0.0004 in.	> 0.016 in. ±3%
Slightly Positive	< -0.010 in. ±3%	0.002 ±0.0004 in.	> 0.014 in. ±3%
Zero	< -0.012 in. ±3%	0.000 ±0.0004 in.	> 0.012 in. ±3%
Slightly Negative	< -0.014 in. ±3%	-0.002 ±0.0004 in.	> 0.010 in. ±3%
Negative	< -0.016 in. ±3%	-0.004 ±0.0004 in.	> 0.008 in. ±3%

- **AirFlow PID Gain:** The proportional multiplier (gain) for the evaporator fan when an AFC is present. The proportional multiplier adjusts for the difference (error) between the measured value and the setpoint.
- **AirFlow PID Integral:** The integral multiplier (reset rate) for the evaporator fan when an AFC is present. The integral multiplier adjusts for error measurement and the amount of time that the error has existed. The integral multiplier adds to or subtracts from the output in small increments to correct for the offset error caused by the proportional contribution.
- **AirFlow PID Derivative:** The derivative multiplier (derivative) for the evaporator fan when an AFC is present. The derivative multiplier adjusts the output for rapid changes in the error, correcting for the rate of change of the error over time.
- **AirFlow PID Reset:** Select **Yes** to reset the airflow control PID values to factory default settings.
- **Condenser Temperature Setpoint:** Enter the setpoint that will be used by the condenser temperature controller in two conditions: One condition is when the evaporating temperature is less than or equal to 0°C (32°F); the other condition is when the condensing temperature sensor does not provide a value. (10.0–93.3°C (50.0–200.0°F))
- **Supply Air Control:** Displays whether the PID algorithm for the supply air is running (**Run**) or not (**Stop**).
- **Supply Air Setpoint:** The required temperature of the air expelled into the surrounding environment. (15.0–30.2°C (59.0–86.4°F))
- **Delta-T Setpoint:** When the group is programmed for HACS or RACS mode, this value specifies the desired temperature difference between the supply and return air temperatures when an AFC is not present. (**10F/5.6C, 15F/ 8.3C, 20F/11.1C, 25F/13.9C, 30F/16.7C, 35F/19.4C, 40F/22.2C**)
 - NOTE:** Set a lower **Cool Setpoint** or a smaller **Delta-T Setpoint** to assist with start-up during winter.
- **Supply Air PID Gain:** The proportional multiplier (gain) for the supply air sensors installed on the unit. The proportional multiplier adjusts for the difference (error) between the measured value and the setpoint.

- **Supply Air PID Integral:** The integral multiplier (reset rate) for the supply air temperature sensors installed on the unit. The integral multiplier adjusts for error measurement and the amount of time that the error has existed. The integral multiplier adds to or subtracts from the output in small increments to correct for the offset error caused by the proportional contribution.
- **Supply Air PID Derivative:** The derivative multiplier (derivative) for the supply air temperature sensors installed on the unit. The derivative multiplier adjusts the output for rapid changes in the error, correcting for the rate of change of the error over time.
- **Supply Air PID Reset:** Select **Yes** to reset the supply air temperature PID values to factory default settings.
- **Rack Inlet Control:** Displays whether or not the PID algorithm for the rack inlet air temperature is running (**Run**) or not (**Stop**).
- **Cool Setpoint:** Set the temperature that the cooling group should maintain in the IT space. (17.8–35.0°C (64.0–95.0°F))
- **Rack Inlet PID Gain:** The proportional multiplier (gain) for the rack inlet air temperature sensors connected to the unit. The proportional multiplier adjusts for the difference (error) between the measured value and the setpoint.
- **Rack Inlet PID Integral:** The integral multiplier (reset rate) for the rack inlet air temperature sensors connected to the unit. The integral multiplier adjusts for error measurement and the amount of time that the error has existed. The integral multiplier adds to or subtracts from the output in small increments to correct for the offset error caused by the proportional contribution.
- **Rack Inlet PID Derivative:** The derivative multiplier (derivative) for the rack inlet air temperature sensors connected to the unit. The derivative multiplier adjusts the output for rapid changes in the error, correcting for the rate of change of the error over time.
- **Rack Inlet PID Reset:** Select **Yes** to reset the rack inlet air temperature PID values to factory default settings.

Tune the PID Loop

Tune the PID loop to optimize the performance of the cooling group.

NOTE: This procedure is to be performed by Schneider Electric qualified personnel only. The PID loop must be tuned after the equipment in the room is installed and running. The loop should be tuned periodically to account for changes in the room load.

1. Adjust the integral and derivative constants to zero and the proportional constant to 1.0.
2. Set the temperature setpoint value and start the cooling group.
3. When the temperature reaches a stable value, increase the proportional constant by 0.5. If the temperature does not respond to this change, adjust the setpoint.
4. Repeat step 3 until the temperature value starts to oscillate and the peak amplitude of the oscillations is constant.
5. Note the time, in minutes, between the peaks of the oscillations. This is the Ultimate Period, P_U .
6. Note the value of the proportional constant. This is the Ultimate Gain, G_U .
7. Compute the PID constants using the table below. Use the equations for that control method in the row to compute the values for each constant.
8. Set each constant according to these calculations.

Control Method	Proportional	Integral	Derivative
P	$0.5 * G_U$	—	—
P+I	$0.45 * G_U$	$0.54 * G_U / P_U$	—
P+I+D	$0.6 * G_U$	$1.2 * G_U / P_U$	$0.075 * G_U * P_U$

The PID loop may need to be further tuned in the following ways to account for changes in the room load:

Loop Behavior	PID Tuning Correction
Slow response to temperature changes	Increase the proportional multiplier or increase the derivative multiplier.
Overcooling/undercooling after changes in the room load or changes in setpoint	Increase the derivative or the proportional multiplier.
Environmental temperature never reaches the setpoint	Increase the integral multiplier.
Overcooling/undercooling on constant room load	Decrease the integral multiplier.

Maintenance

Maintenance Mode

NOTICE

UNIT MALFUNCTIONS

- Changing the settings incorrectly can cause malfunctions to the cooling unit in use.
- Only qualified service personnel should make changes to these settings.

Failure to follow these instructions can result in equipment damage.

Path: Main > Configuration > Service > Maintenance Mode

Maintenance mode is used to perform maintenance checks. Qualified personnel can manually control components within the unit to check for errors and mechanical issues. The unit must be in an **Off** state before being put in maintenance mode. Press **OK** next to each setting to accept changes. Some data items are duplicated on multiple screens to provide the status of components while adjusting settings.

- **Maintenance Mode:** Select which type of maintenance mode to enter.
 - **Enable_Indefinitely:** The unit will remain in maintenance mode until it is disabled.
 - **Enable_With_Timeout:** The unit will remain in maintenance mode for two minutes.
 - **Disable:** The unit will exit maintenance mode and resume normal operation.
- **Maximum Cooling:** Select **Max** to set all of the maintenance mode actuator settings to the maximum output: condenser fan, evaporator fan, EEV position, and compressor speed.
- **EEV Position:** The current open percentage of the electronic expansion valve. (%)
- **Suction Pressure:** The pressure of the refrigerant at the suction line. (bar (psi))
- **Discharge Pressure:** The pressure of the refrigerant at the discharge line. (bar (psi))
- **Compressor Speed:** Enter a speed to which the compressor will be manually commanded. (0.0–100.0 Hz)
- **Avg. Fan Speed:** The current average speed of the eight fans in the indoor unit. (rpm)
- **Fan Speed:** The current speed of the evaporative fans. (%)
- **Fan Speed:** Enter a fan speed percentage to manually control the evaporator fans. (0.0–100.0 %)
- **EEV Position:** The current open percentage of the electronic expansion valve. (%)
- **EEV Position:** Enter an open percentage for the electronic expansion valve. When the compressor speed is greater than 0 Hz, the EEV is controlled by the superheat PID controller. (0.0–100.0%)
- **Liquid Line Solenoid:** The current state of the liquid line solenoid valve: **Open** or **Closed**.
- **Liquid Line Solenoid:** Select to open or close the liquid line solenoid valve. When the compressor speed is set greater than 0 Hz, the liquid line is forced open. (**Open** or **Closed**)
- **Electric Heater 1:** Select **Open** or **Closed** to control the heater relay.

NOTE: For ACRD301P and ACRD301R units only.

- **Electric Heater 2:** Select **Open** or **Closed** to control the heater relay.
NOTE: For ACRD301P and ACRD301R units only.
- **CPY Humidifier Request:** The condensate production request to the humidifier controller. Available on units equipped with a humidifier only. (%)
NOTE: For ACRD301P and ACRD301H units only.
- **Manual Drain:** Select **Yes** to manually drain the humidifier canister; select **No** to not manually drain the humidifier canister.
NOTE: For ACRD301P and ACRD301H units only.
- **Humidifier Actual Production:** The actual amount of condensate produced by the humidifier. (%)
NOTE: For ACRD301P and ACRD301H units only.
- **Humidifier Current:** The humidifier electrical current in amps. Available on units equipped with a humidifier only.
NOTE: For ACRD301P and ACRD301H units only.
- **Humidifier Water Conductivity:** The conductivity level of the water in the humidifier. Available on units equipped with a humidifier only. ($\mu\text{S}/\text{cm}$)
NOTE: For ACRD301P and ACRD301H units only.
- **Alarm Relay 1:** Select open or closed to control the alarm relays. (**Open** or **Closed**)
- **Alarm Relay 2:** Select open or closed to control the alarm relays. (**Open** or **Closed**)
- **Alarm Relay 3:** Select open or closed to control the alarm relays. (**Open** or **Closed**)
- **Alarm Relay 4:** Select open or closed to control the alarm relays. (**Open** or **Closed**)
- **Outlet Evap Coil Temperature:** The temperature of the refrigerant leaving the evaporative coil. ($^{\circ}\text{C}$ ($^{\circ}\text{F}$))
- **Inlet Evap Coil Temperature:** The temperature of the refrigerant entering the evaporative coil. ($^{\circ}\text{C}$ ($^{\circ}\text{F}$))
- **Upper Supply Temperature:** The temperature from the top supply air temperature sensor connected to this unit. ($^{\circ}\text{C}$ ($^{\circ}\text{F}$))
- **Lower Supply Temperature:** The temperature from the bottom supply air temperature sensor connected to this unit. ($^{\circ}\text{C}$ ($^{\circ}\text{F}$))
- **Upper Return Temperature:** The temperature from the top return air temperature sensor connected to this unit. ($^{\circ}\text{C}$ ($^{\circ}\text{F}$))
- **Lower Return Temperature:** The temperature from the bottom return air temperature sensor connected to this unit. ($^{\circ}\text{C}$ ($^{\circ}\text{F}$))
- **Suction Pressure:** The pressure of the refrigerant at the suction line. (bar (psi))
- **Discharge Pressure:** The pressure of the refrigerant at the discharge line. (bar (psi))
- **EEV Position:** The current open percentage of the electronic expansion valve. (%)
- **Liquid Line Solenoid:** The current state of the liquid line solenoid valve: **Open** or **Closed**.
- **Fan Speed:** The current speed of the evaporative fans. (%)

Monthly Preventive Maintenance

Photocopy the following pages and use them during the maintenance procedures. After they have been completed, save them for future reference.

Prepared By: _____

Model Number: _____

Serial Number: _____

Date: _____

Perform the following monthly maintenance check lists.

Environment

- Supply air temperature sensor reading: _____
- Return air temperature sensor reading: _____
- Record the alarm history for the last month.

Cleanliness

- Check the condition of the air filters. Clean or change if necessary.
- Check the condition of the condenser coil. Remove large debris.

Mechanical Checks

DANGER

HAZARD OF ELECTRIC SHOCK, EXPLOSION, OR ARC FLASH

- Apply appropriate personal protective equipment (PPE) and follow safe electrical work practices.
- This equipment must be installed and serviced by qualified and trained personnel only.
- Turn off all power supplying this equipment before working on or inside the equipment.
- Replace all devices, doors, and covers before turning on power to this equipment.

Failure to follow these instructions will result in death or serious injury.

WARNING

HAZARD TO EQUIPMENT OR PERSONNEL

All work must be performed by Schneider Electric qualified and trained personnel.

Failure to follow these instructions can result in death, serious injury, or equipment damage.

- Check the evaporator fans for abnormal noise or vibration.
- Check the liquid line sight glass moisture indicator.
- Check the liquid line sight glass for bubbles.
- Check the oil level in the compressor sight glass.
- Check the condenser fans for abnormal noise or vibration.

Electrical Checks

DANGER

HAZARD OF ELECTRIC SHOCK, EXPLOSION, OR ARC FLASH

- Apply appropriate personal protective equipment (PPE) and follow safe electrical work practices.
- This equipment must be installed and serviced by qualified and trained personnel only.
- Turn off all power supplying this equipment before working on or inside the equipment.
- Replace all devices, doors, and covers before turning on power to this equipment.

Failure to follow these instructions will result in death or serious injury.

WARNING

HAZARD TO EQUIPMENT OR PERSONNEL

All work must be performed by Schneider Electric qualified and trained personnel.

Failure to follow these instructions can result in death, serious injury, or equipment damage.

- Inspect the electrical panel doors and covers for damage or loose hardware.
- Check the condenser electrical panel and covers for damage or loose hardware.

Functional Tests

- Check the operation of the display interface.

Quarterly Preventive Maintenance

Photocopy the following pages and use them during the maintenance procedures. After they have been completed, save them for future reference.

Prepared By: _____

Model Number: _____

Serial Number: _____

Date: _____

Perform the following quarterly maintenance check lists in addition to the monthly check lists.

Environment

- Record the **Supply Air Setpoint**: _____
- Record the **Cool Setpoint**: _____

Cleanliness

- Check for debris in the condensate pan. Clean as needed.

Mechanical Checks

⚡ ⚠ DANGER

HAZARD OF ELECTRIC SHOCK, EXPLOSION, OR ARC FLASH

- Apply appropriate personal protective equipment (PPE) and follow safe electrical work practices.
- This equipment must be installed and serviced by qualified and trained personnel only.
- Turn off all power supplying this equipment before working on or inside the equipment.
- Replace all devices, doors, and covers before turning on power to this equipment.

Failure to follow these instructions will result in death or serious injury.

⚠ WARNING

HAZARD TO EQUIPMENT OR PERSONNEL

All work must be performed by Schneider Electric qualified and trained personnel.

Failure to follow these instructions can result in death, serious injury, or equipment damage.

- Record the suction and discharge pressures: _____
- Record the evaporator superheat temperature: _____

Electrical Checks

DANGER

HAZARD OF ELECTRIC SHOCK, EXPLOSION, OR ARC FLASH

- Apply appropriate personal protective equipment (PPE) and follow safe electrical work practices.
- This equipment must be installed and serviced by qualified and trained personnel only.
- Turn off all power supplying this equipment before working on or inside the equipment.
- Replace all devices, doors, and covers before turning on power to this equipment.

Failure to follow these instructions will result in death or serious injury.

WARNING

HAZARD TO EQUIPMENT OR PERSONNEL

All work must be performed by Schneider Electric qualified and trained personnel.

Failure to follow these instructions can result in death, serious injury, or equipment damage.

- Check wiring harnesses and molded connectors.
- Check customer interface wiring connections.
- Check temperature and humidity sensor connections.

Semi-Annual Preventive Maintenance

Photocopy the following pages and use them during the maintenance procedures. After they have been completed, save them for future reference.

Prepared By: _____

Model Number: _____

Serial Number: _____

Date: _____

Perform the following semi-annual maintenance check lists in addition to the monthly and quarterly check lists.

Environment

-
- Check for visible damage to the cooling unit.
 - Check for dirt, dust, debris, and liquid stains in and around the cooling unit.
-

Cleanliness

-
- Check for debris in the condensate pan. Clean as needed.
 - Check and clean the evaporator coil.
 - Check and clean the condenser coil.
-

Mechanical Checks

DANGER

HAZARD OF ELECTRIC SHOCK, EXPLOSION, OR ARC FLASH

- Apply appropriate personal protective equipment (PPE) and follow safe electrical work practices.
- This equipment must be installed and serviced by qualified and trained personnel only.
- Turn off all power supplying this equipment before working on or inside the equipment.
- Replace all devices, doors, and covers before turning on power to this equipment.

Failure to follow these instructions will result in death or serious injury.

WARNING

HAZARD TO EQUIPMENT OR PERSONNEL

All work must be performed by Schneider Electric qualified and trained personnel.

Failure to follow these instructions can result in death, serious injury, or equipment damage.

- Check for refrigerant leaks on valves, threaded connections, and heat exchangers.
- Check refrigerant piping clamps and insulation. Secure as needed.
- Check that the condensate line is not obstructed or clogged.

Electrical Checks

DANGER

HAZARD OF ELECTRIC SHOCK, EXPLOSION, OR ARC FLASH

- Apply appropriate personal protective equipment (PPE) and follow safe electrical work practices.
- This equipment must be installed and serviced by qualified and trained personnel only.
- Turn off all power supplying this equipment before working on or inside the equipment.
- Replace all devices, doors, and covers before turning on power to this equipment.

Failure to follow these instructions will result in death or serious injury.

WARNING

HAZARD TO EQUIPMENT OR PERSONNEL

All work must be performed by Schneider Electric qualified and trained personnel.

Failure to follow these instructions can result in death, serious injury, or equipment damage.

- Check circuit breaker and fuse block electrical connections.
- Check low voltage transformers, measure and record output voltage.
- Measure and record mains input voltage: _____
- Check and tighten electrical connections on the compressor inverter drive.
- Check and record the current draw for the following components:
 - Fans: _____
 - Compressor: _____
- Check condenser electrical components, fuses, contactors, speed controller.

Functional Tests

- Check the operation of the water leak detection device.
- Verify the cooling operation mode is functioning properly.
- Check condensate pump operation.

Troubleshooting

If necessary, call Technical Support describing the nature of the fault and its possible cause displayed on the control panel.

Problem	Possible Cause	Corrective Action
Controls erratic or inoperative	Inlet temperature to cooling unit is higher than rated maximum temperature	Reduce the load or add additional cooling equipment.
Fans fail to start	Cooling unit shutdown due to an external command	Temporarily remove the input contact cable, if it is connected.
	Single fan fails to start	Verify that the fan circuit breaker is ON.
Cooling unit cannot obtain setpoint	Improper placement of remote temperature sensor	Verify that the remote temperature sensor is properly located in the cold aisle.
	Dirty filter	Clean the filter.
	Dirty coil	Clean the coil.
	Application error	Contact Schneider Electric technical support
	Heat load is too far away	Place the cooling unit closer to the heat load.
Water carryover	Improper fan speed selected	HACS mode only: Select the next-highest fan speed setting.
	Room humidity is too high	Improve room sealing.
Temperature control not tight enough	Improper placement of remote temperature sensor	Verify that the remote temperature sensor is properly located in the cold aisle.
Water on outside of cooling unit	Condensate drain hose is not connected or not properly routed outside the cooling unit	Verify that the condensate drain hose is properly connected to the pump and properly routed outside of the cooling unit. Verify that the condensate drain line does not exceed 3.5 m (11.5 ft) lift and 18.0 m (60.0 ft) horizontal run.
	Leak in drain system	Locate and repair the leak.
	Cooling unit not leveled properly	Adjust the leveling feet of the cooling unit.
	Damaged piping insulation	Identify damaged area and repair the insulation.
Display interface not operational, but cooling unit operates	Display interface not connected properly	Verify that the display interface cable is connected properly.
Airflow switch is energized	False filter clogs	Verify that the ends of the clear plastic air tubes are not obstructed. Verify that the clear plastic air tubes are connected to the controller. Verify that the clear plastic air tubes are not pinched.
Alarms do not show up on monitoring equipment (Customer Output Contact)	External monitoring equipment is not receiving power or is not functioning properly	Confirm that power, if required, is being supplied to the external equipment. If the cooling unit (+12 V or +24 V) is providing power to the external equipment, verify that the external equipment is ≤ 50 mA. Test the external equipment by bypassing the customer output contact. Verify Customer Output Contact settings.

Problem	Possible Cause	Corrective Action
Cooling unit does not shut down on command	Drive voltage	<p>Verify that there is a drive voltage entering the input of the cooling unit. It is possible to use the available +12 V or +24 V. Also the ground must be used.</p> <p>Verify Customer Input Contact settings.</p>
No communication with building management system (BMS) port	Improper connection	<p>Confirm that the cooling unit is connected to the BMS port and not to the Control port.</p> <p>Make sure that the wire polarity is correct. Using a DC voltmeter, test the signal with no transmissions in progress. Expect the voltage at pin 2 to be greater than at pin 1 by at least 200 mV. Measure the cooling unit with the cable disconnected, and then measure it again with the cable connected. If the signal is less than 200 mV, the cooling unit may be reverse-wired.</p> <p>Make sure that every cooling unit has either two sets of wires in its connector or one set of wires and a terminating resistor of 100 to 120 ohms.</p>
Cooling units are not communicating with each other	A-Link failure	<p>Verify that the first and last cooling units have one cable and a terminator.</p> <p>Verify that every other cooling unit has two cables.</p> <p>Verify that the addresses of the units in the group are unique. To do that power on the units one by one for checking.</p> <p>Confirm that the A-Link cables are connected to the ALink ports and that a network cable is connected to the network port.</p>
Fans are running at a very high rate of speed.	Upper or lower supply air sensor	<p>Either upper or lower supply air temperature sensor has a fault. Verify that both supply air temperature sensors are installed and working properly.</p>

Worldwide Customer Support

Customer support for this product is available at no charge in any of the following ways:

- Visit the Schneider Electric Web site to access documents in the Schneider Electric Knowledge Base and to submit customer support requests.
 - www.se.com (Corporate Headquarters)
Connect to localized Schneider Electric websites for specific countries, each of which provides customer support information.
 - www.se.com/support/
Get global support by searching the Schneider Electric Knowledge Base and using esupport.
- Contact the Schneider Electric Customer Support Center by telephone or e-mail.
Go to www.se.com > **Support** > **Contact Support** to find contact information for country-specific centers.

For information on how to obtain local customer support, contact the representative or other distributors from whom you purchased your product.

Schneider Electric
35 rue Joseph Monier
92500 Rueil Malmaison
France

+ 33 (0) 1 41 29 70 00

www.se.com

As standards, specifications, and design change from time to time,
please ask for confirmation of the information given in this publication.

© 2022 – 2022 Schneider Electric. All rights reserved.

990-2022725-001