

Valve terminal VTUX

FESTO

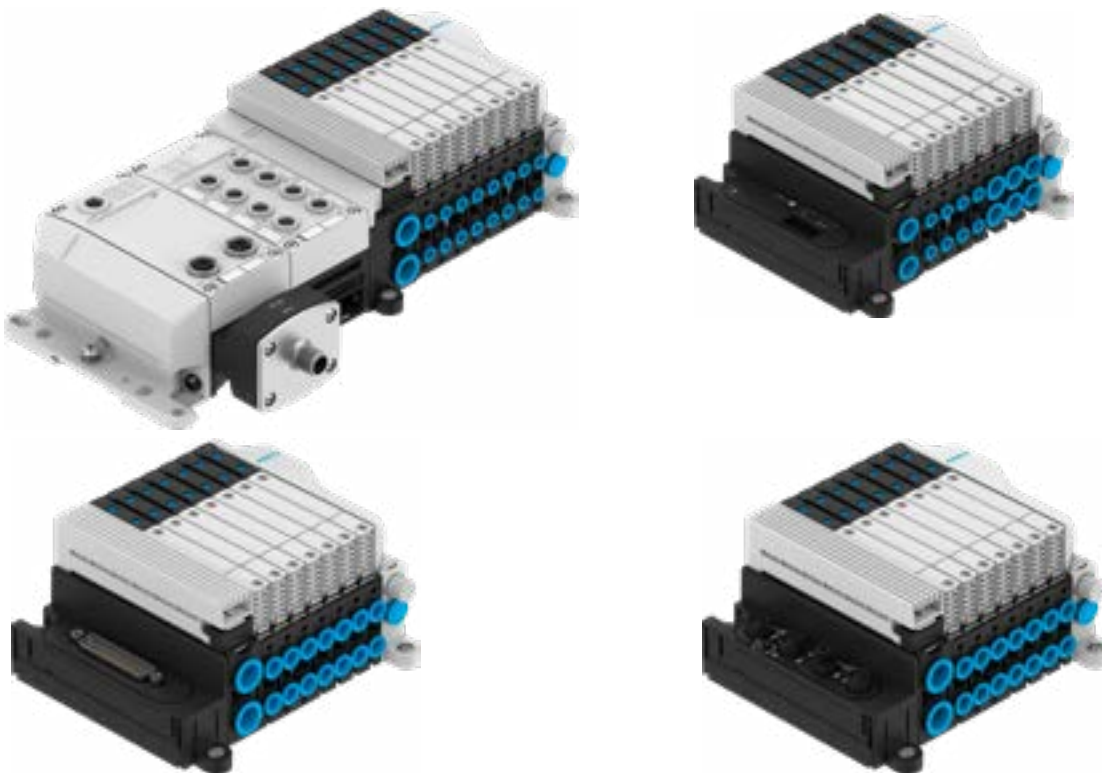

Key features

**Innovative**

- Compact design with low overall height and width
- Manifold sub-bases with different widths for different flow rate with the same valves
- Flow rate up to 670 l/min
- Flexibly configurable push-in fittings as a cartridge, easy to exchange in just a few simple steps
- Wide range of electrical connection options for multi-pin plug: Sub-D, ribbon cable or spring-loaded terminal
- Connection to the automation system CPX-AP-I
- Connection to the automation system CPX-AP-A
- IO-Link® interface

Versatile

- Modular system offering a range of configuration options
- Manifold sub-bases for 4 valves or an individual valve, can be combined as required
- System can be extended as needed with individual manifold sub-bases and modular tie rods
- Up to 32 solenoid coils
- Can be converted and extended at a later date
- Air supply can be extended via additional pressure zones using supply modules
- Can be assembled using individually ordered components

Reliable

- High output reserves thanks to large pneumatic cross sections and exhausting with high flow rates
- Resilient thanks to high mechanical rigidity
- Lightweight polymer components
- Fast troubleshooting with LEDs on the valves
- Easy to service with replaceable valves and manifold sub-bases
- Manual override either non-detenting, detenting or secured against unauthorised activation (concealed)

Easy to install

- Fast and reliable delivery as a ready-to-install and tested unit or for self-assembly from individual components
- Reduced selection, ordering, installation and commissioning costs
- Secure wall mounting or H-rail mounting

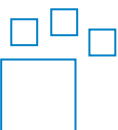
Ordering data – Product options

Configurable product
This product and all its product options can be ordered using the configurator.

The configurator can be found at
→ www.festo.com/catalogue/...
Enter the part number or the type.

Part no.	Type
8000800	VTUX-A-P
8000810	VTUX-A-P-APA
8000850	VUX

Key features

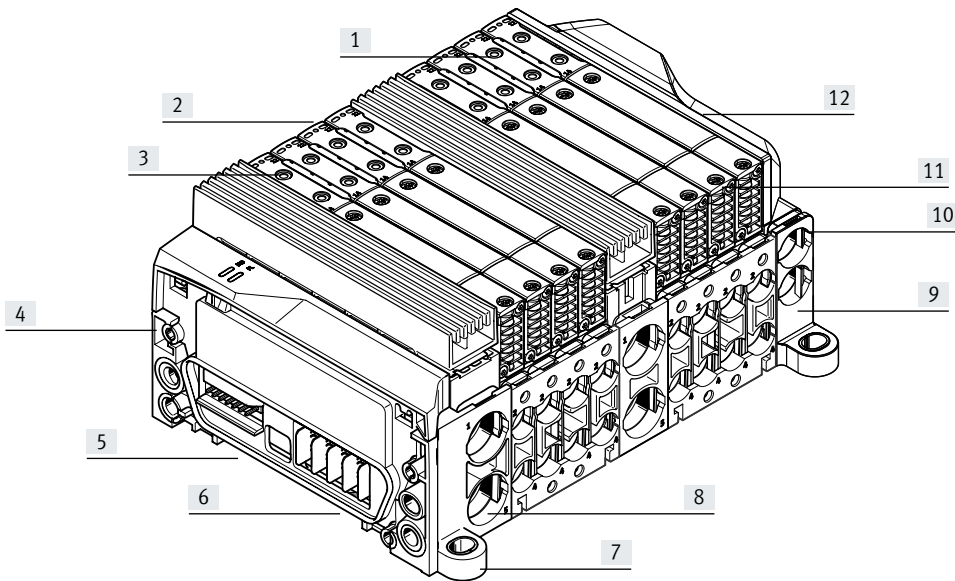

- | | | | |
|---|---|---|---|
| <p>[1] Valves in width 10 mm and manifold sub-bases in widths of 10 mm and 12 mm</p> <p>[2] Reduced downtime: LED signal status indicator</p> <p>[3] Safe operation: Manual override, non-detenting/detenting or concealed</p> <p>[4] Pneumatic interface to CPX-AP-A</p> | <p>[5] Simple electrical connection
– Multi-pin plug connection
– Fieldbus interface CPX-AP-A
– Interface CPX-AP-I
– IO-Link®</p> <p>[6] Reliable: Operating voltage connection, outputs and valves can be disconnected separately</p> <p>[7] Quick to mount: Directly using screws or on an H-rail</p> | <p>[8] Practical: Pre-assembled cartridges can be exchanged in just a few steps</p> <p>[9] Adaptable: The pilot air supply (internal or external) is selected using a separator in the end plate</p> <p>[10] Variable: 32 valve positions/32 solenoid coils</p> | <p>[11] Space-saving: Flat valves and flat plate silencer</p> <p>[12] Modular: Pressure zone creation, additional exhaust and supply ports possible using supply module</p> |
|---|---|---|---|

Equipment options

Valve functions

- 5/2-way valve, single solenoid
- 5/2-way valve, double solenoid
- 2x 3/2-way valve, normally open
- 2x 3/2-way valve, normally closed
- 5/3-way valve, mid-position closed

Special features

- Max. 32 valve positions/
max. 32 solenoid coils
- Parallel, modular valve links
- Any compressed air supply
- Creation of pressure zones possible
- Modular, individually extendable tie rods
- Single valves or combinations of four valves
- Freely selectable tubing size at each port

Key features

Control variants of the valve terminal VTUX

The VTUX can be integrated in control systems in a variety of ways. There are a range of designs available for actuation via electrical multi-pin connection. Likewise, valve terminals can be connected via IO-Link® using round plugs with a high degree of protection or using terminal connections.

The valve terminals are particularly versatile and high-performing thanks to the perfect integration into the Festo AP Automation Platform. In combination with the automation system CPX-AP-A, valve terminals with various peripheral modules can be readily configured and assembled.

Integration into the automation system CPX-AP-I offers numerous options, especially for decentralised solutions. It is thus possible to have particularly space-saving solutions close to the pneumatic drives, enabling rapid movements and short cycle times.

Being able to combine the valve terminal with the automation system CPX-AP-A as well as CPX-AP-I creates a unique solution for central and decentralised machine functions. This modularity makes the VTUX perfectly adaptable to any application.

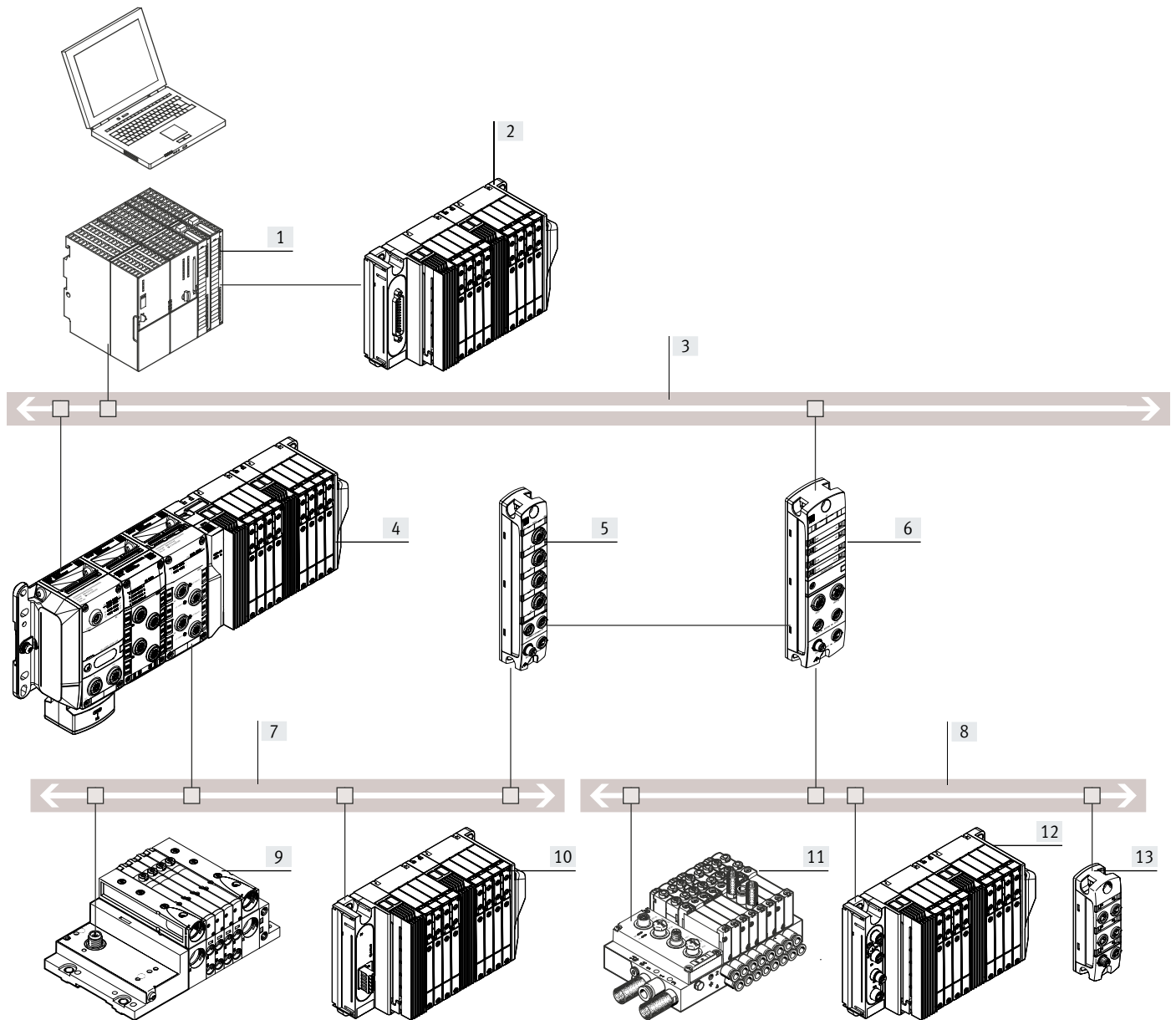

- [1] Higher-order controller (PLC)
- [2] VTUX with multi-pin plug connection
- [3] Fieldbus
- [4] VTUX with automation system CPX-AP-A with fieldbus interface
- [5] IO-Link master of the automation system CPX-AP-I
- [6] Bus node of the automation system CPX-AP-I
- [7] IO-Link
- [8] AP bus
- [9] Components from Festo with IO-Link interface (e.g. valve terminal MPA-S)
- [10] VTUX with IO-Link node
- [11] Components from Festo with AP bus interface (e.g. valve terminal MPA-S)
- [12] VTUX with pneumatic interface for automation system CPX-AP-I
- [13] Input/output module with AP bus

Key features

Valve terminal selection

Valve terminal configurator

The appropriate valve terminal VTUX can be selected quickly and easily using the online catalogue. This includes a convenient valve terminal configurator, making it much easier to order the right product.

The valve terminals are assembled according to your order specification and are individually checked. This reduces assembly and installation time to a minimum.

Order a valve terminal VTUX using the order code.

Ordering system for VTUX

→ Internet: vtux

Ordering system for CPX-AP-I

→ Internet: cpx-ap-i

Online at: → www.festo.com

2D/3D CAD data

You can request the CAD data for a valve terminal you have configured. To do so, start the product search as described above. Click on the CAD/EPLAN symbol. On the next page, you can generate a 3D preview or request a data format of your choice via e-mail.

Multi-pin plug connection

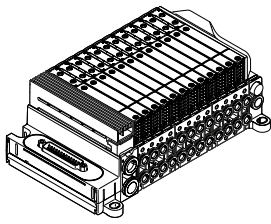

The signals are transmitted from the controller to the valve terminal via a pre-assembled or self-assembled multi-core cable to the multi-pin plug connection. This substantially reduces installation time.

The valve terminal can be equipped with max. 32 solenoid coils. This corresponds to 2 to 32 valves.

Versions:

- Sub-D connection
 - Pre-assembled multi-pin cable
 - Multi-pin cable for self-assembly
- Ribbon cable connection
- Terminal strip connection

Fieldbus interface via the automation system CPX-AP-I

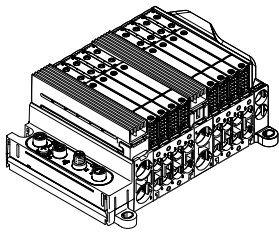

CPX-AP-I is a flexible, decentralised, compact and lightweight automation system with high degree of protection IP65/IP67.

An automation system CPX-AP-I consists of a bus interface and at least one other module. System communication between the modules takes place via connecting cables.

The process data is exchanged cyclically. The following module types are available:

- Bus interface
- Input modules
- Input/output modules
- Interface for valve terminal

Fieldbus protocols in combination with VTUX:

- PROFINET
- EtherNet/IP
- EtherCAT®

Fieldbus interface via the automation system CPX-AP-A

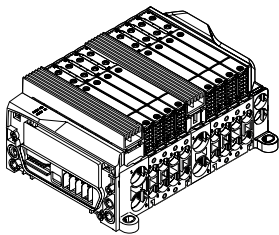

CPX-AP-A is a flexible, central, compact and lightweight automation system with high degree of protection IP65/IP67.

A bus node directly mounted on the valve terminal VTUX manages communication with a higher-order PLC.

A compact unit, combining pneumatics, sensors and a bus interface, can be designed using directly linked input and output modules.

Fieldbus protocols:

- PROFINET
- EtherNet/IP
- EtherCAT®

IO-Link®

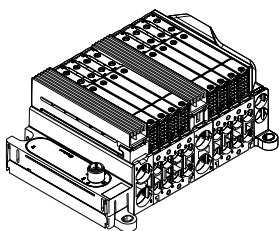

IO-Link® consists of a central master and the IO-Link® devices connected via special connecting cables. This permits a decentralised layout of the devices.

The connection type corresponds to a star topology.

As well as transmitting the communication data, the IO-Link® interfaces also handle the power supply for the connected devices.

The maximum length of a string is 20 m.

Peripherals overview

Modular pneumatic components

The modular design of the valve terminal VTUX enables outstanding flexibility right from the planning stage and offers maximum ease of service in operation.

The system consists of manifold sub-bases and valves.

The manifold sub-bases form the support system for the valves.

They contain the electrical links, the ducts for supplying compressed air to and exhausting the valve terminal as well as the working ports for the pneumatic drives for each valve.

The manifold sub-bases are connected by a tie rod system. This comprises a tie rods and a screw set. The combination of tie rods and screw set is selected according to the chosen number of individual sub-bases.

A valve terminal can be easily extended by adding individual manifold sub-bases or supply modules. This is done simply by inserting suitable tie rod extenders.

This ensures that the valve terminal can be rapidly and reliably extended.

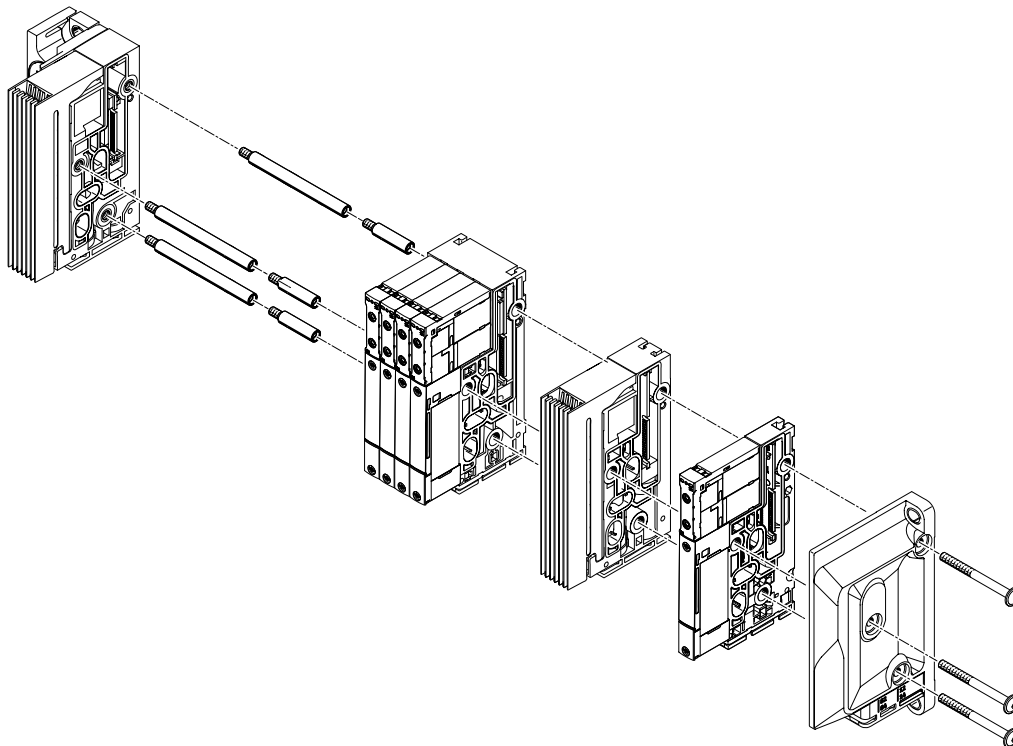

Note

The tie rod system for the valve terminal VTUX consists of at least two manifold sub-bases or one manifold sub-base and one supply module.

Modular electrical peripherals

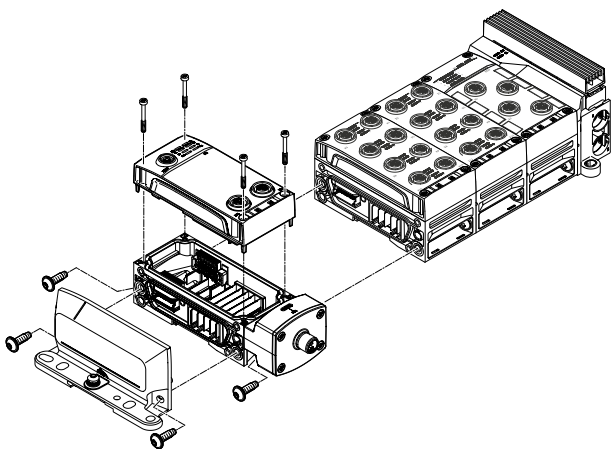

The mechanical connection between the CPX-AP-A modules is created using angled fittings.

The automation system CPX-AP-A can be flexibly expanded at any time. The advantages of polymer (low weight) and metal (sturdy, high EMC compatibility) are perfectly combined by using high-quality polymer materials.

The input/output modules, manifold blocks and bus node of the automation system CPX-AP-A are fastened to the interlinking blocks using 4 screws and can be exchanged or modified in nearly any way.

Peripherals overview

Pneumatic components of the valve terminal

The manifold sub-bases are available individually with one valve position or with a grid of four valve positions.

The manifold sub-bases include the electrical links for:

- Single solenoid valves or
- Double solenoid valves
- Double solenoid valve positions occupy two addresses and can be equipped with any valve or a cover plate.
- Single solenoid valve positions occupy a single address and can only be equipped with single solenoid valves or a cover plate.

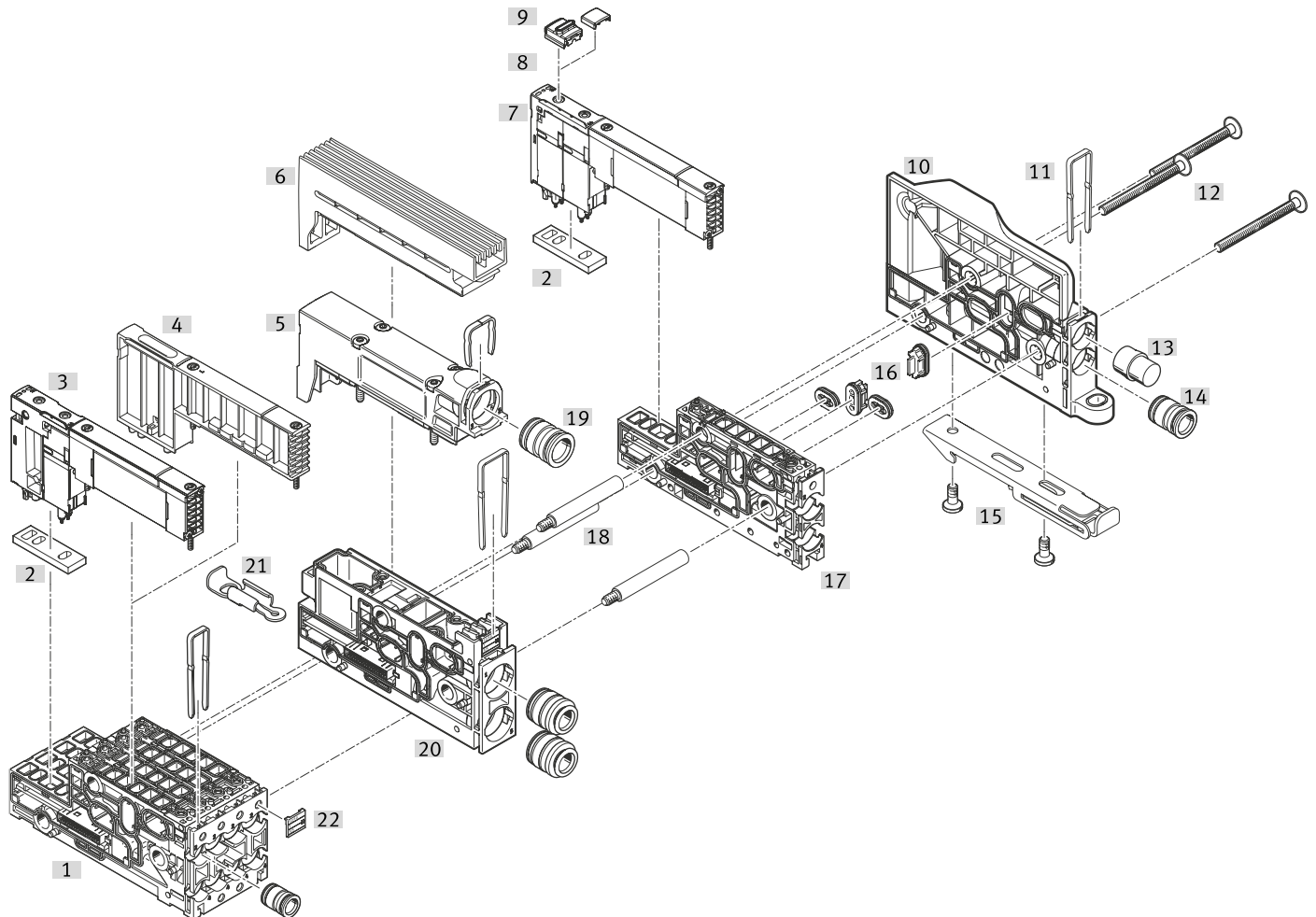

Peripherals overview

Pneumatic components of the valve terminal			
Designation	Brief description	→ Page/Internet	
[1]	Manifold sub-base	Manifold sub-base with four valve positions	36
[2]	Seal	–	–
[3]	Solenoid valve	Valve size 10 mm	36
[4]	Vacant position	Cover plate for one valve position	36
[5]	Plate	Exhaust plate for ducted exhaust air	36
[6]	Plate	Exhaust plate as flat plate silencer	36
[7]	Solenoid valve	Valve size 10 mm	36
[8]	Cover cap for manual override	Conversion from non-detenting to detenting	37
[9]	Cover cap for manual override	Conversion from non-detenting to concealed	37
[10]	Right end plate	- End plate with ports 12/14, 82/84	38
[11]	Clamping clip for cartridge	–	–
[12]	Screw	Tie rod system, connects the manifold sub-bases	37
[13]	Silencer	with cartridge connection	39
[14]	Cartridge	For air supply and exhaust ports	39
[15]	Mounting	Clamping kit for H-rail mounting	37
[16]	Separator	Separator for pressure zone separation in duct 1 and duct 3, 5	37
[17]	Manifold sub-base, individual	Manifold sub-base with one valve position	36
[18]	Tie rod	Threaded rod, clamps the manifold sub-bases between the end plates	37
[19]	Cartridge	For air supply and exhaust ports	39
[20]	Supply module	For compressed air supply/exhaust air	36
[21]	Mounting	Mounting bracket for wall mounting	37
[22]	Inscription labels	For identifying the pressure zone separation	37

Peripherals overview

Valve terminal with multi-pin plug connection:

Order code:

- VTUX-A-P-M...

Valve terminals VTUX with multi-pin plug connection can be expanded by up to 32 solenoid coils/valve positions.

The multi-pin plug connection can be ordered as a Sub-D connection (25- or 44-pin) or as a terminal strip (34-pin) or as a ribbon cable connection (26-pin).

The Sub-D multi-pin plug connection (25- and 44-pin) is available with degree of protection IP40 and IP65; the terminal strip and ribbon cable connection with IP40.

Pre-assembled cables of different lengths with degree of protection IP40 or IP65/67 are available as accessories for the Sub-D multi-pin plug connection (25- and 44-pin).

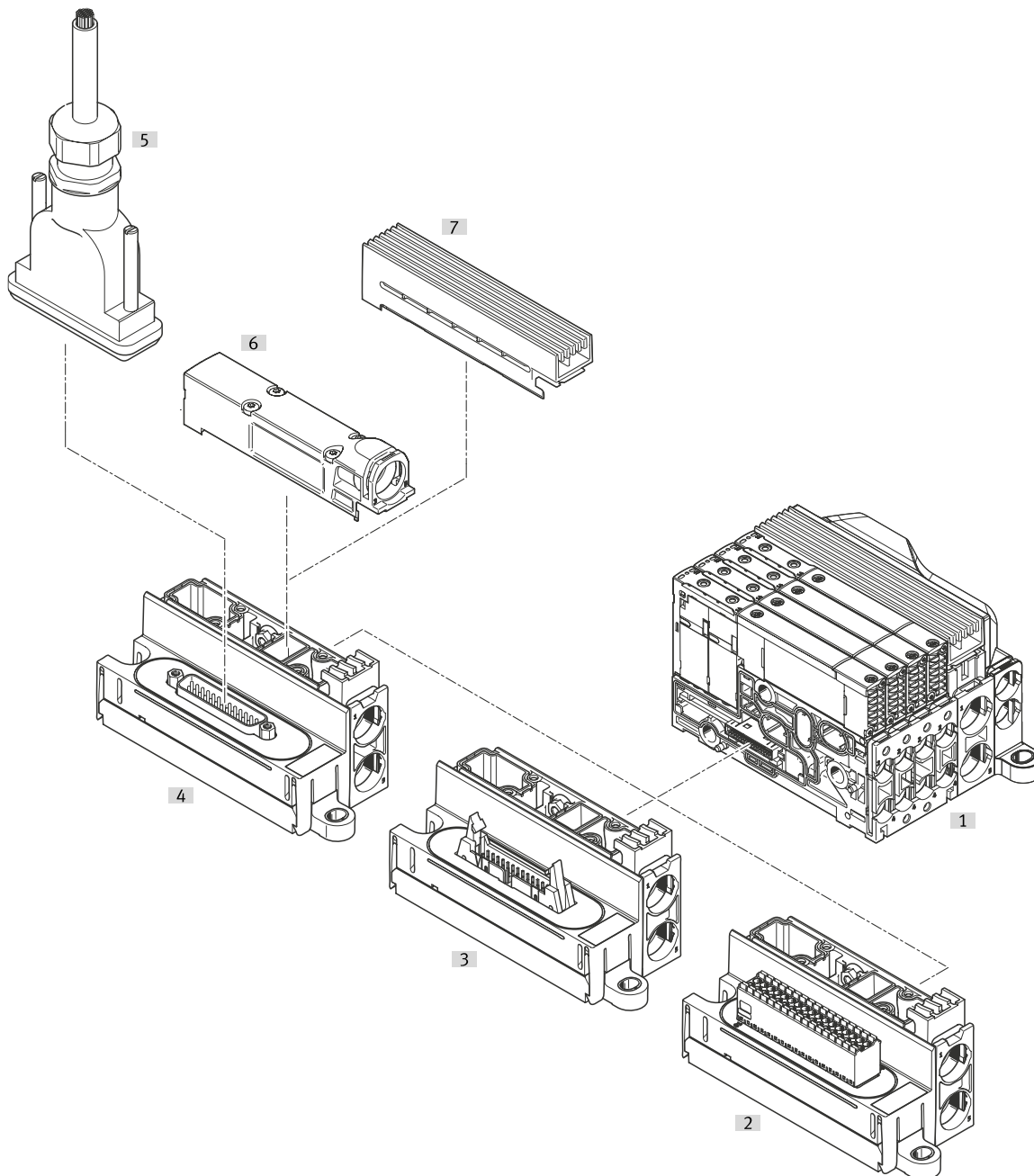

Designation	Brief description	→ Page/Internet
[1] Valve terminal VTUX	Pneumatic part	7
[2] Multi-pin plug connection	Terminal strip	38
[3] Multi-pin plug connection	For ribbon cable, 40-pin, IP40	38
[4] Multi-pin plug connection	Sub-D, 25-pin	38
[5] Connecting cable	Socket 25-pin, Sub-D, open cable end 25-pin	39
[6] Plate	Exhaust plate for ducted exhaust air	36
[7] Plate	Exhaust plate as flat plate silencer	36

Peripherals overview

Valve terminal with fieldbus interface, automation system CPX-AP-A

Order code:

- VTUX-A-P-APA-... for the pneumatics
- CPX-AP-A-... for the electrical peripherals

Valve terminals with CPX-AP-A interface can be expanded by up to 32 solenoid coils/valve positions.

Up to 32 valve positions can be equipped with single solenoid valves. The maximum number of valve positions is reduced to 16 if only valves with two solenoid coils are used (double solenoid valves, 5/3-way valves, 2x 3/2-way valves).

Each valve position can be equipped with any valve or a cover plate. The rules for CPX-AP-A apply to the equipment that can be used with the electrical peripherals CPX-AP-A.

In general:

- Digital inputs/outputs
- Parameterisation of inputs and outputs
- Integrated, convenient diagnostics
- Preventive maintenance concepts

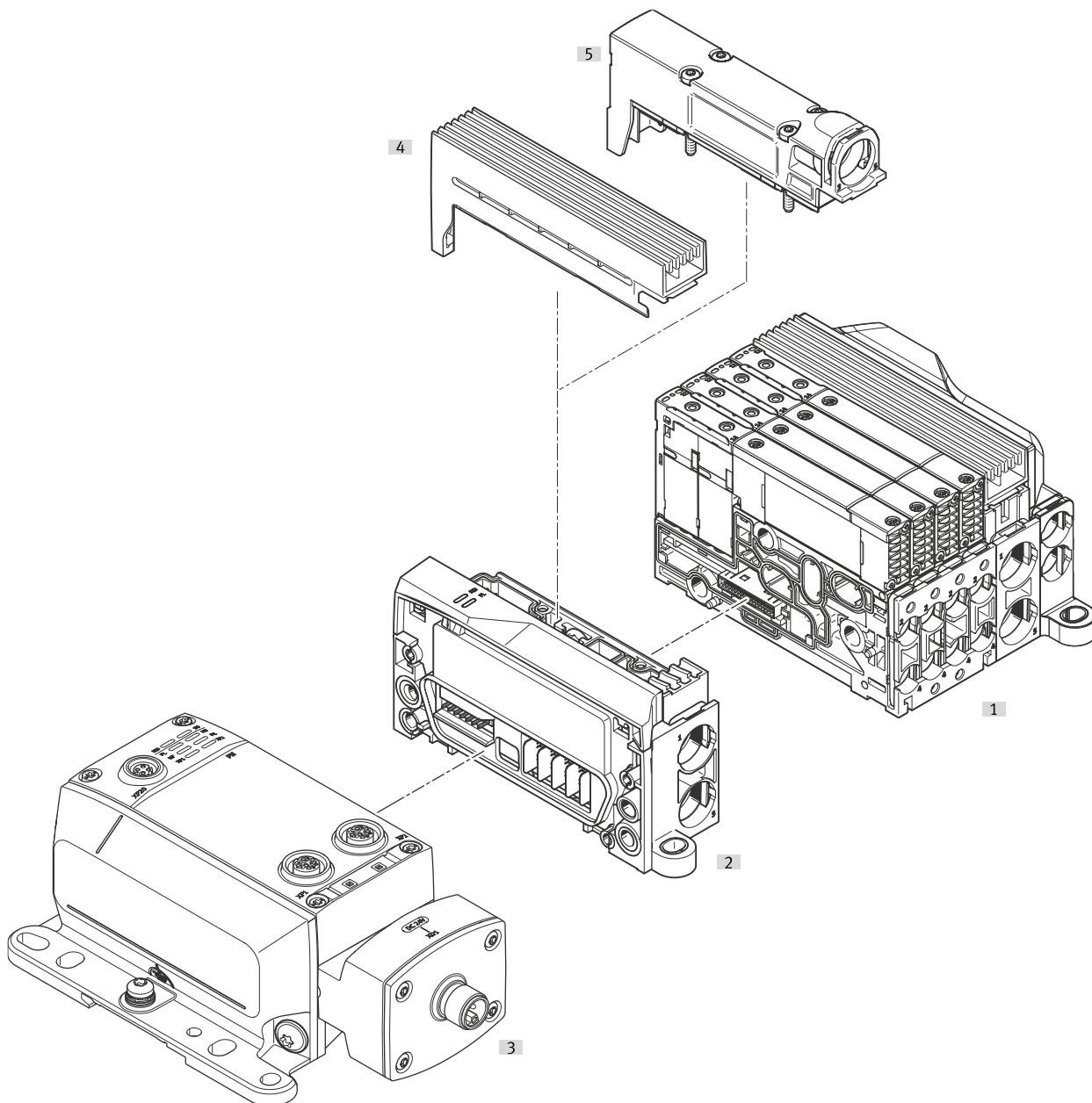

Designation	Brief description	→ Page/Internet
[1] Valve terminal VTUX	Pneumatic part	7
[2] Left end plate	Pneumatic interface for automation system CPX-AP-A	38
[3] Automation system CPX-AP-A	Electrical part of the automation system CPX-AP-A	cpx-ap-a
[4] Plate	Exhaust plate as flat plate silencer	36
[5] Plate	Exhaust plate for ducted exhaust air	36

Peripherals overview

Valve terminal with interface to automation system CPX-AP-I

Order code:

- VTUX-A-P-API... for the pneumatic components
- CPX-AP-I components are to be ordered individually

Valve terminals with CPX-AP-I interface can be expanded by up to 32 solenoid coils/valve positions.

Up to 32 valve positions can be equipped with single solenoid valves.

The maximum number of valve positions is reduced to 16 if only valves with two solenoid coils are used (double solenoid valves, 5/3-way valves, 2x 3/2-way valves).

Each valve position can be equipped with any valve or a cover plate.

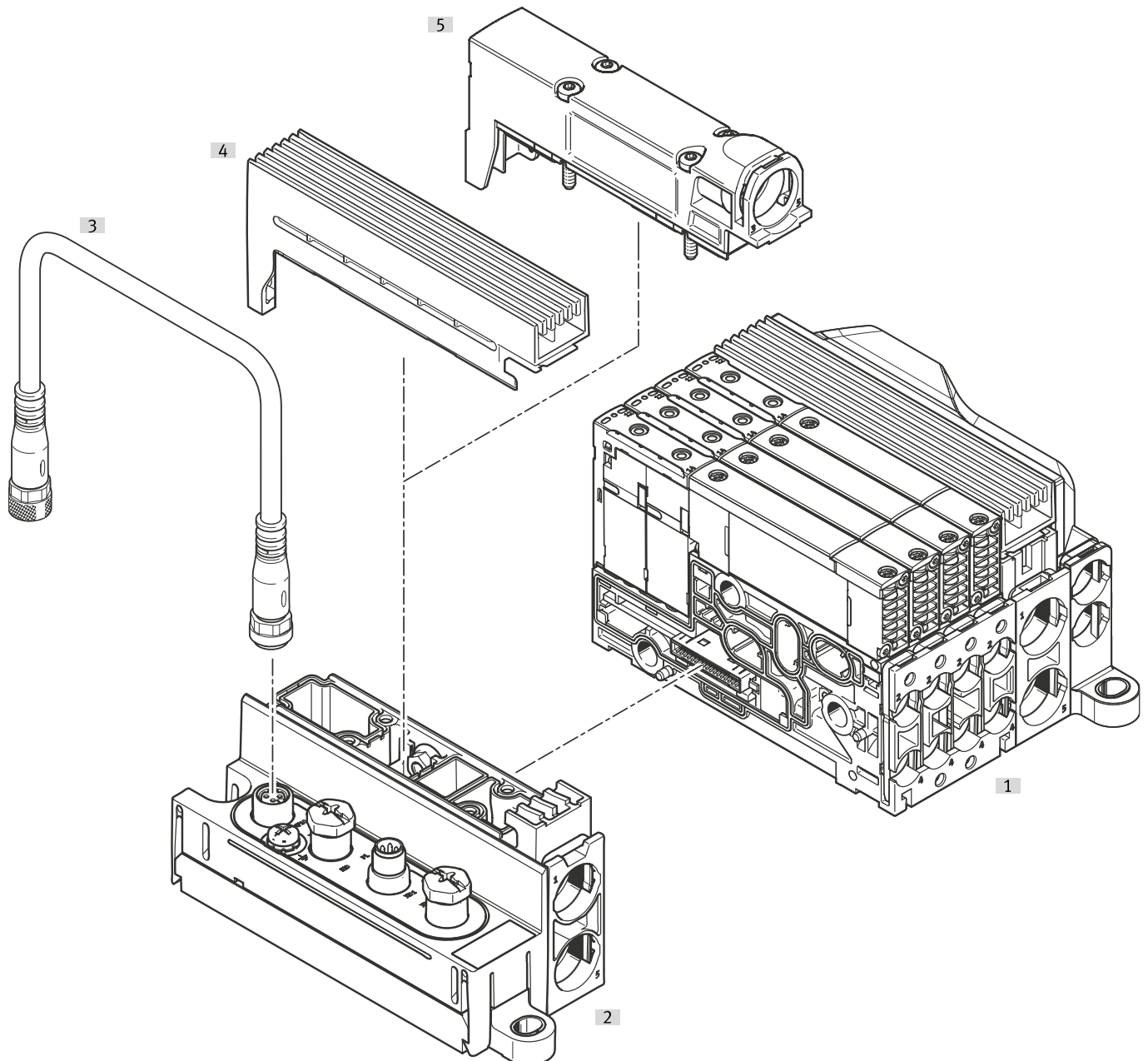

Designation	Brief description	→ Page/Internet
[1] Valve terminal VTUX	Pneumatic part	7
[2] Left end plate	End plate with interface to the automation system CPX-API and with interface for power supply	38
[3] Connecting cable	Between two CPX-AP-I modules	cpx-ap-i
[4] Plate	Exhaust plate as flat plate silencer	36
[5] Plate	Exhaust plate for ducted exhaust air	36

Peripherals overview

Valve terminal with IO-Link® interface (and bus node)

Order code:

- VTUX-A-P-IO... for the pneumatic components
- CTEU... for the bus node

Valve terminals with IO-Link® interface can be expanded by up to 32 solenoid coils/valve positions.

Up to 32 valve positions can be equipped with single solenoid valves.

The maximum number of valve positions is reduced to 16 if only valves with two solenoid coils are used (double solenoid valves, 5/3-way valves, 2x 3/2-way valves).

Each valve position can be equipped with any valve or a cover plate.

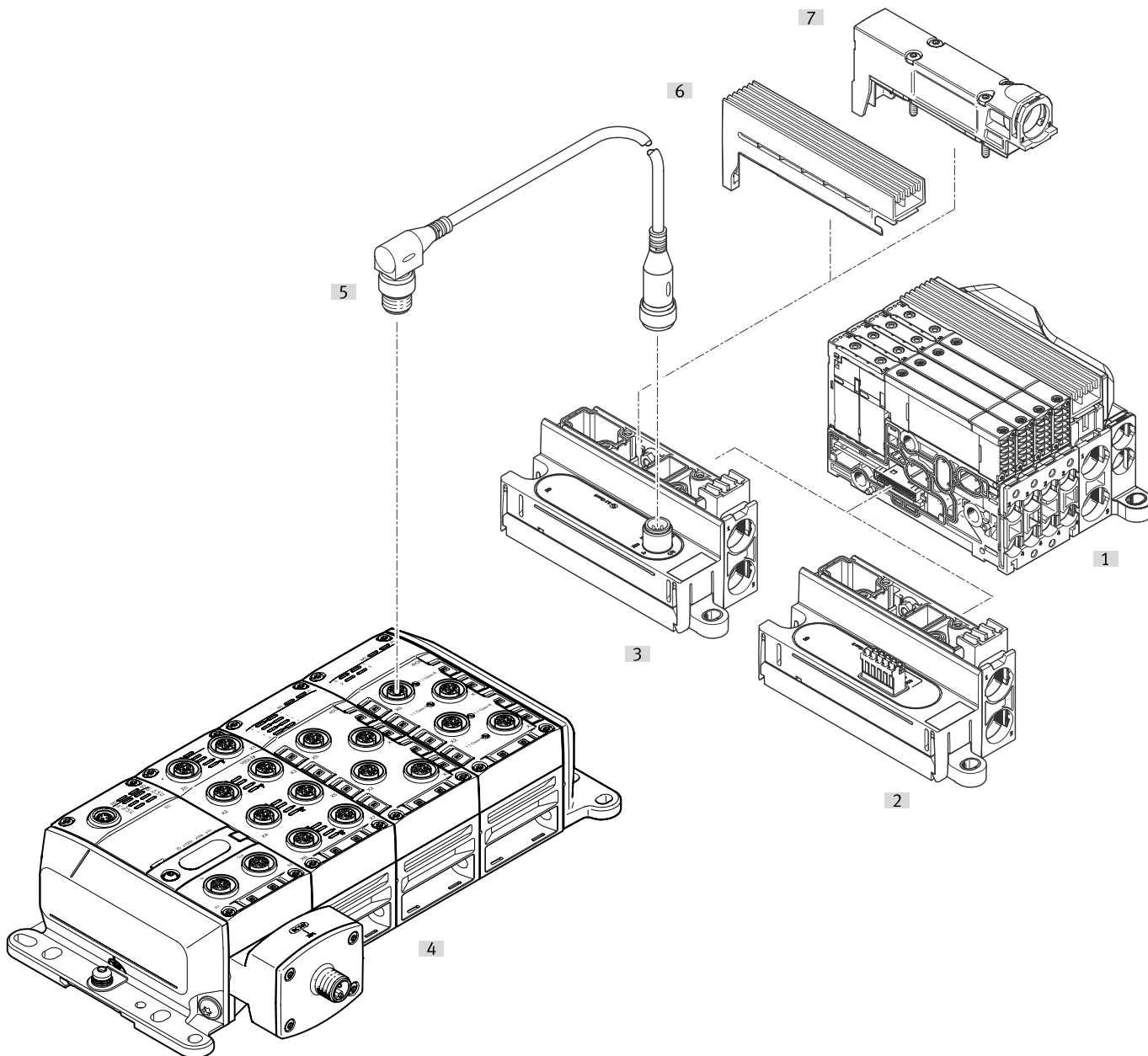

Designation	Brief description	→ Page/Internet
[1] Valve terminal VTUX	Pneumatic part	7
[2] Left end plate	End plate with IO-Link® interface, push-in electrical connection	38
[3] Left end plate	End plate with IO-Link® interface, M12 electrical connection	38
[4] Automation system CPX-AP-A	With bus node, input/output modules and IO-Link master for connecting devices with IO-Link interface	cpx-ap-a
[5] Connecting cable	Between two IO-Link® interfaces	nebu
[6] Plate	Exhaust plate as flat plate silencer	36
[7] Plate	Exhaust plate for ducted exhaust air	36

Key features – Pneumatic components

Sub-base valve

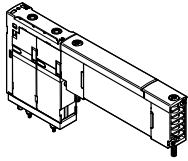

VTUX offers a comprehensive range of valve functions. The spool valves VTUX of width 10 mm offer a particularly high flow rate. They are used on manifold sub-bases of width 10 mm and 12 mm with a tubing connection up to 8 mm.

Valves of size 10 mm are the a particularly effective option for compact valve terminals that also enable applications with outstanding flow rate performance when using 8 mm tubing connections.

This eliminates having to select and decide between different valve sizes and reduces the complexity for planned applications.

Mounting valves on manifold sub-bases offers a range of advantages. The valves are secured using two screws and can be easily replaced.

In terms of valve engineering, 5/2-way and 3/2-way valves have negative overlap. This thus enables the working ports to be exhausted in the de-energised state.

Pilot air (duct 12/14) is supplied via the manifold sub-bases, allowing it to be interrupted and exhausted.

All valves have pneumatic pilot control for optimising performance.

Irrespective of the valve function, there are sub-base valves with one solenoid coil (single solenoid) or with two solenoid coils (double solenoid or two single solenoid valves in one housing).

Design

Replacing valves

The valves are attached to the sub-base using two screws. The tubing remains on the manifold sub-base, which prevents mix-ups during servicing.

As a result, the valves can be easily replaced. The sturdy mechanical structure of the sub-base ensures efficient, durable sealing.

Extension

Cover plates for reserve positions can be replaced by valves at a later date.

The dimensions, mounting points as well as the existing pneumatic installation do not change.

Note

A filter must be installed upstream of valves operated in vacuum mode. This prevents any foreign matter in the intake air getting into the valve (e.g. when operating a suction cup).

5/2-way valve

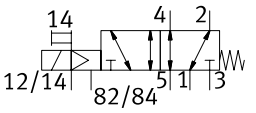
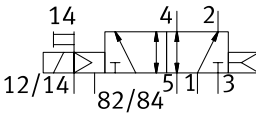
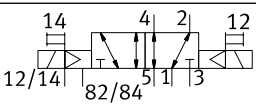
Circuit symbol	Code	Assigned addresses	Description
	Position function 1-32: A	1	<ul style="list-style-type: none"> • Single solenoid • Mechanical spring return • Reversible • Operating pressure –0.09 ... +0.7 MPa
	Position function 1-32: M	1	<ul style="list-style-type: none"> • Single solenoid • Pneumatic spring return • Operating pressure +0.2 ... +0.7 MPa
	Position function 1-32: J	2	<ul style="list-style-type: none"> • Double solenoid • Limited reversibility • Operating pressure –0.09 ... +0.7 MPa

Key features – Pneumatic components

2x 3/2-way valve			
Circuit symbol	Code	Assigned addresses	Description
	Position function 1-32: NS	2	<ul style="list-style-type: none"> • Single solenoid • Normally open • Mechanical spring return • Reversible • Operating pressure 0 ... 0.7 MPa
	Position function 1-32: K	2	<ul style="list-style-type: none"> • Single solenoid • Normally closed • Mechanical spring return • Reversible • Operating pressure 0 ... 0.7 MPa
	Position function 1-32: KC	2	<ul style="list-style-type: none"> • Single solenoid • Normally closed • Pneumatic spring return • Operating pressure 0.15 ... 0.7 MPa
5/3-way valve			
Circuit symbol	Code	Assigned addresses	Description
	Position function 1-32: G	2	<ul style="list-style-type: none"> • Mid-position closed • Mechanical spring return • Reversible • Operating pressure -0.09 ... +0.7 MPa

 **Note**

The valve functions of an exhausted and pressurised 5/3-way valve can be realised using the 3/2-way valves "normally closed" and "normally open", respectively, with mechanical spring return.

The negative overlap makes it possible to exhaust the working ports in the de-energised state.

Key features – Pneumatic components

Cover plate

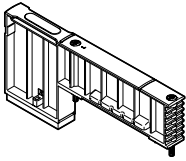

Cover plate (code L) without valve function, for reserving valve positions on a valve terminal.

Valves and cover plates are attached to the manifold sub-base using two screws.

Compressed air supply and exhaust

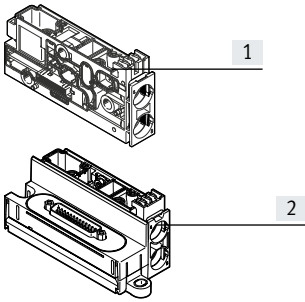

- [1] Supply module
[2] Left end plate

The valve terminal VTUX can be supplied with compressed air at one or more points via the left end plate and/or via supply modules. The generously sized pneumatic system ensure that all components will offer good performance, even with large-scale extensions.

Exhausting (ducts 3 and 5) takes place either via silencers or ports for ducted exhaust air, via the supply modules or the left end plate.

There are two variants for exhausting:

- Exhaust air 3/5 via flat plate silencer
- Exhaust air 3/5 ducted

Ducts 3 and 5 are separate in the terminal and are only joined together in the supply module/left end plate. The pilot exhaust air (duct 82/84) is completely separate from ducts 3 and 5.

Pilot air supply

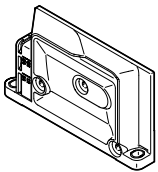

The valve terminal VTUX is supplied with pilot air only via the right end plate.

The type of pilot air supply can be selected using a separator in duct 1 of the end plate:

- Internal (from duct 1) or
- External (from duct 12/14)

The actual required pilot pressure depends on the valves used on the valve terminal.

With a sufficiently high supply pressure on the valve terminal, internal pilot air supply can be chosen.

In this case, the pilot air supply is diverted through an internal connection from duct 1 in the right end plate.

The operating pressure in the right pressure zone must be at least equal to the highest required pilot pressure of the entire valve terminal.

Port 12/14 on the right end plate is sealed using a blanking plug.

-  - **Note**

If a gradual pressure build-up in the system using a soft-start valve is chosen, an external pilot air supply should be connected so that the pilot pressure applied during switch-on is already very high.

Key features – Pneumatic components

Compressed air supply and pilot air supply		
Illustration	Code	Information
Right end plate, with supply ports		
	Pilot air supply, via right end plate: -	Internal pilot air supply <ul style="list-style-type: none"> • Pilot air is branched internally from port 1 in the right end plate • Port 12/14 in the right end plate is sealed using a blanking plug • Pilot exhaust air 82/84 via right end plate • For operating pressure in the range 0.25 ... 0.7 MPa
	Pilot air supply, via right end plate: Z	External pilot air supply <ul style="list-style-type: none"> • Pilot air supply (0.25 ... 0.7 MPa) is connected at port 12/14 on the right end plate • Port 1 in the right end plate is sealed using a separator • Pilot exhaust air 82/84 via right end plate • For operating pressure in the range -0.09 ... +0.7 MPa (suitable for vacuum)
Supply module, flat plate silencer		
	Connection position type 1-64: U Position function 1-64: US	<ul style="list-style-type: none"> • Exhaust air 3/5 via flat plate silencer • Pilot exhaust air 82/84 via right end plate • For operating pressure in the range -0.09 ... +0.7 MPa (suitable for vacuum)
Supply module, ducted exhaust air		
	Connection position type 1-64: U Position function 1-64: UD	<ul style="list-style-type: none"> • Exhaust air 3/5 via supply module • Pilot exhaust air 82/84 via right end plate • For operating pressure in the range -0.09 ... +0.7 MPa (suitable for vacuum)

Key features – Pneumatic components

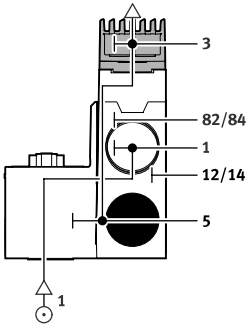
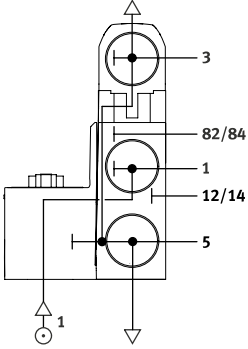
Compressed air supply and pilot air supply		
Illustration	Code	Information
Left end plate, flat plate silencer		
	–	<ul style="list-style-type: none"> • Exhaust air 3/5 via flat plate silencer • Pilot exhaust air 82/84 via right end plate • For operating pressure in the range $-0.09 \dots +0.7$ MPa (suitable for vacuum)
Left end plate, ducted exhaust air		
	–	<ul style="list-style-type: none"> • Exhaust air 3/5 via supply module • Pilot exhaust air 82/84 via right end plate • For operating pressure in the range $-0.09 \dots +0.7$ MPa (suitable for vacuum)

Key features – Pneumatic components

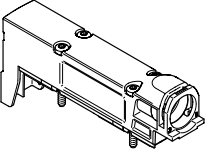
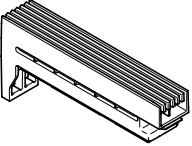
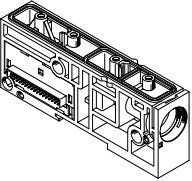
Supply module	Code	Type	Designation	Information
	Position function 1-64: UD	VABF-XA-12-M2	Exhaust plate for ducted exhaust air	Additional supply modules can be used for larger terminals or to create pressure zones. Supply modules can be configured at any point upstream or downstream from the manifold sub-bases or also next to one another. Supply modules contain the following ports: <ul style="list-style-type: none"> • Compressed air supply (duct 1) • Exhaust air (duct 3/5) Depending on your order, the exhaust ducts are either ducted or exhausted via the flat plate silencer. The flat plate silencer is fixed on the manifold sub-base with a latching lug and can be removed without the need for tools.
	Position function 1-64: US	VABF-XA-12-M1	Flat plate silencer	
	Connection position type 1-64: U	VABX-A-P-BU	Supply module without cartridge	

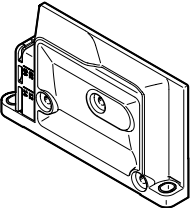
Supply and exhaust ports	Code	Connection	Push-in fitting/cartridge		
Right end plate with supply ports 12/14, 82/84					
		12/14	Pilot air supply	Cartridge	Cartridge, straight
		82/84	Pilot exhaust air	Cartridge	

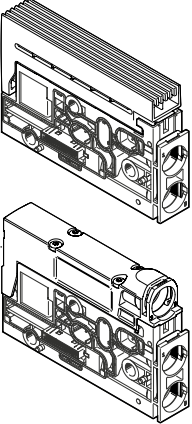
Supply module	Connection position type 1-64: U				
		1	Working air/vacuum supply	Cartridge	Cartridge, straight
		3/5	Exhaust air	Flat plate silencer	–
				Cartridge	Cartridge, straight

Key features – Pneumatic components

Creating pressure zones and separating exhaust air

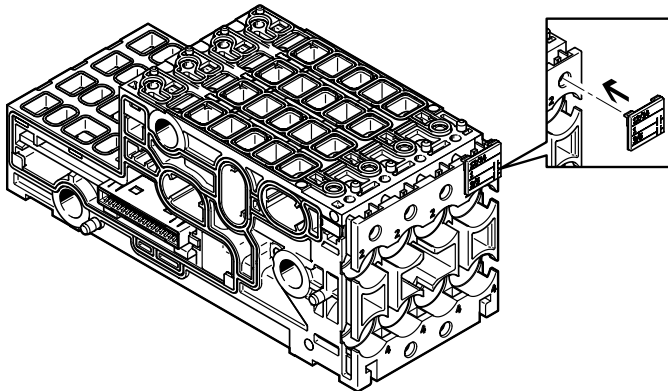

VTUX offers a number of options for creating pressure zones if different working pressures are required. Pressure zones are created by isolating the internal supply ducts between two adjacent manifold sub-bases. Every pressure zone must have its own compressed air supply. Compressed air can be supplied and exhausted via the left end plate and/or the supply modules.

The position of the supply modules and the pressure zone separation can be freely chosen with the valve terminal VTUX.

The separators for pressure zone separation are integrated into the terminal at the factory as specified in your order.

Their position is marked using corresponding inscription labels. Duct separation takes place between two manifold sub-bases.

Creating pressure zones

Manifold sub-bases with separator for pressure zone separation
Illustrated examples

Illustrated examples	Coding	Code	Information			
	<table border="1"> <tr><td>12/14</td></tr> <tr><td>1</td></tr> <tr><td>3/5</td></tr> </table>	12/14	1	3/5	Duct separation 1 - 64: TT	<ul style="list-style-type: none"> [1] Duct 82/84 [2] Duct 3 [3] Duct 1, separated [4] Duct 12/14 [5] Duct 5
12/14						
1						
3/5						
	<table border="1"> <tr><td>12/14</td></tr> <tr><td>1</td></tr> <tr><td>3/5</td></tr> </table>	12/14	1	3/5	Duct separation 1 - 64: TR	<ul style="list-style-type: none"> [1] Duct 82/84 [2] Duct 3, separated [3] Duct 1 [4] Duct 12/14 [5] Duct 5, separated
12/14						
1						
3/5						
	<table border="1"> <tr><td>12/14</td></tr> <tr><td>1</td></tr> <tr><td>3/5</td></tr> </table>	12/14	1	3/5	Duct separation 1 - 64: TS	<ul style="list-style-type: none"> [1] Duct 82/84 [2] Duct 3, separated [3] Duct 1, separated [4] Duct 12/14 [5] Duct 5, separated
12/14						
1						
3/5						

Key features – Pneumatic components

Examples: compressed air supply and pilot air supply

Internal pilot air supply

The diagram on the right shows an example of the configuration and connection of the air supply with internal pilot air supply.

The exhaust air (duct 3/5) is exhausted via supply modules.

The pilot exhaust air (duct 82/84) is discharged via the right end plate.

Special separators are used to create pressure zones.

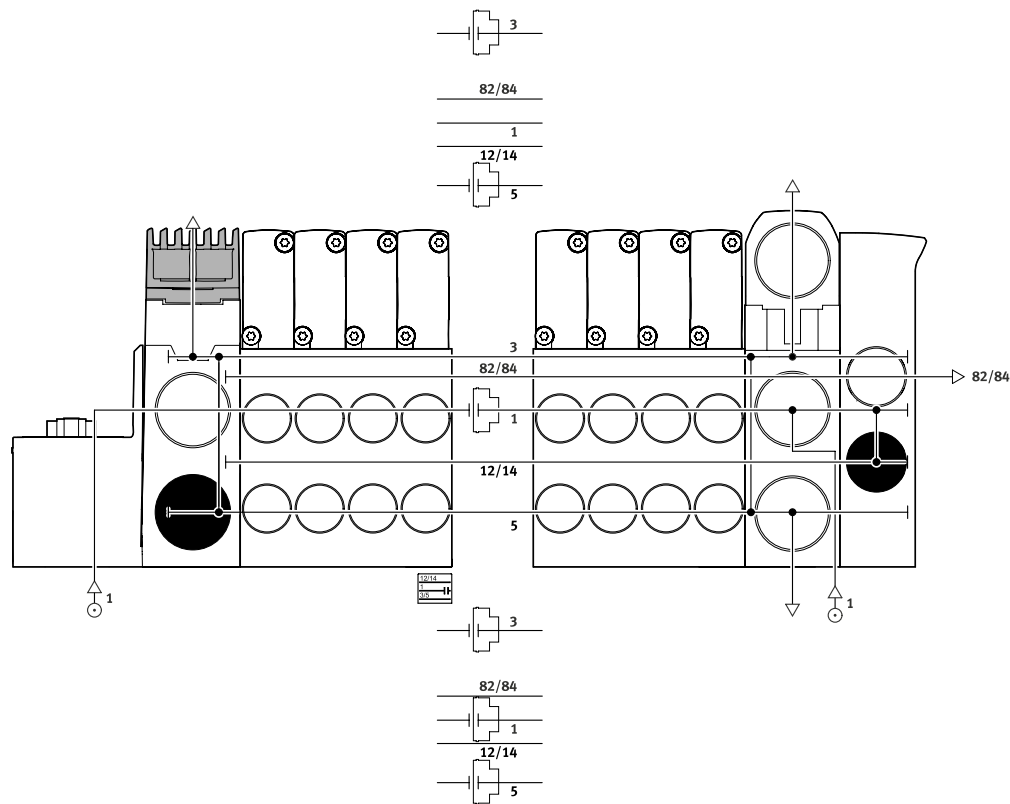

Examples: compressed air supply and pilot air supply

External pilot air supply

The diagram on the right shows an example of the configuration and connection of the compressed air supply with external pilot air supply. Port 12/14 on the right end plate is equipped with a fitting for this.

The exhaust air (duct 3/5) is exhausted via supply modules.

The pilot exhaust air (duct 82/84) is discharged via the right end plate.

Special separators are used to create pressure zones.

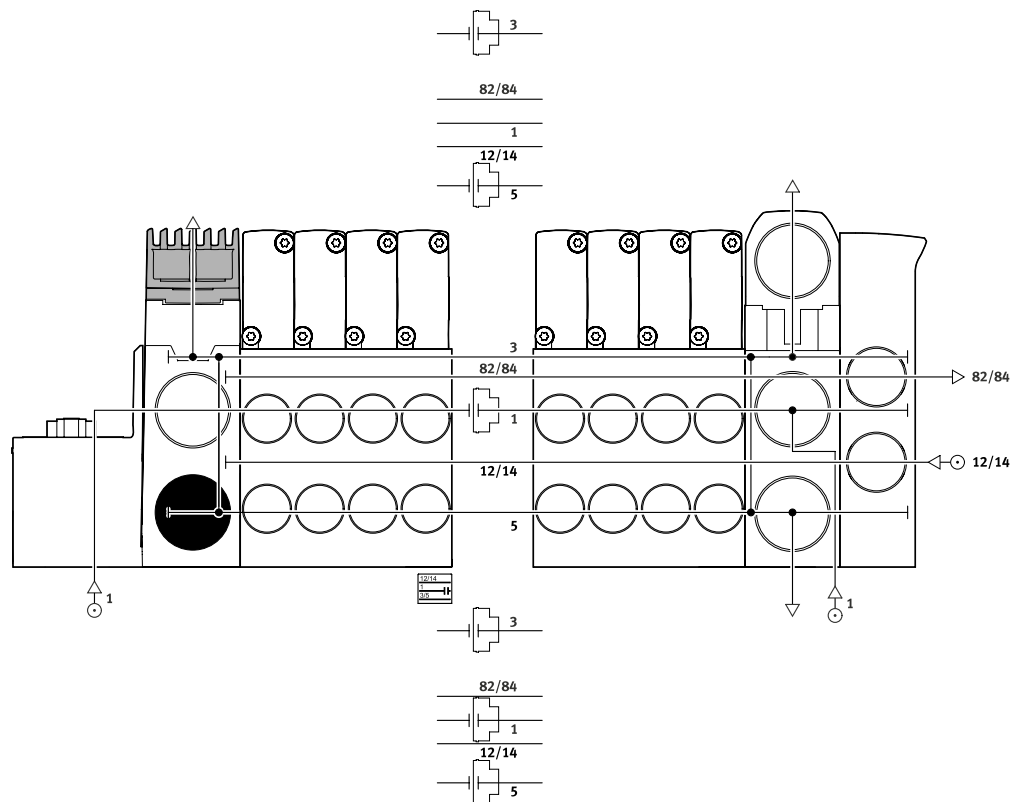

Key features – Pneumatic components

Manifold sub-base

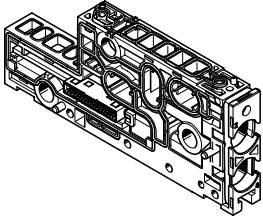

VTUX is based on a modular system which consists of manifold sub-bases and valves. The manifold sub-bases are joined together using tie rods and thus form the support system for the valves.

They contain the ducts for supplying compressed air to and exhausting from the valve terminal as well as the working ports for the pneumatic drives for each valve.

The tie rod used to join the manifold sub-bases together consists of a threaded rod and screw.

The manifold sub-bases are available in variants for one or for four valves. The threaded rod/screw combination is selected according to the number and width of the individual manifold sub-bases.

To add further manifold sub-bases, simply loosen the tie rod and adapt using extenders.

There are no restrictions on how extensions. A tie rod could be constructed almost entirely using extenders.

Manifold sub-base variants

Manifold sub-base variants	Code	Type	Information
	-	VABX-A-P-BV-AH-F VABX-A-P-BV-AH-A	<ul style="list-style-type: none"> • One valve position • Without cartridge • Width 10.55 mm
		VABX-A-P-BV-BH-G VABX-A-P-BV-BH-B	<ul style="list-style-type: none"> • One valve position • Without cartridge • Width 12.55 mm
	-	VABX-A-P-BV-AH-RVFFF VABX-A-P-BV-AH-RVAAAA	<ul style="list-style-type: none"> • Four valve positions • Without cartridge • Width 42.05 mm
		VABX-A-P-BV-BH-RVGGG VABX-A-P-BV-BH-RVBBBB	<ul style="list-style-type: none"> • Four valve positions • Without cartridge • Width 50.05 mm

Key features – Mounting

Valve terminal mounting

Sturdy terminal mounting via:

- Four through-holes for wall mounting
- Additional mounting brackets
- H-rail mounting

Wall mounting

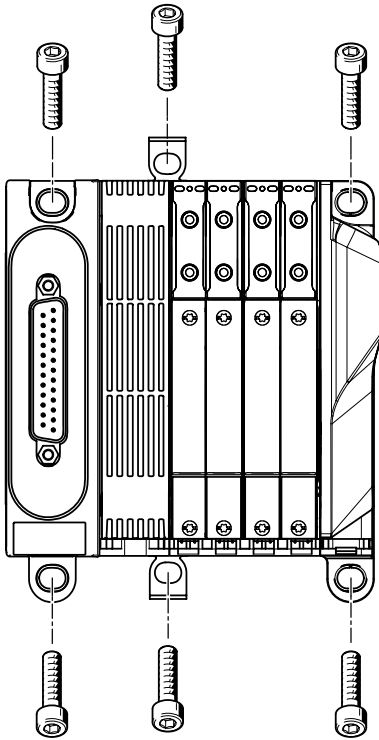

The valve terminal VTUX is screwed onto the mounting surface using four M4 or M6 screws. The mounting holes are on the multi-pin plug connection and on the right end plate. Optional mounting brackets are also available.

**Note**

For wall mounting, in addition to the mounting holes, mounting brackets must be attached to the end plates every 20 cm.

H-rail mounting

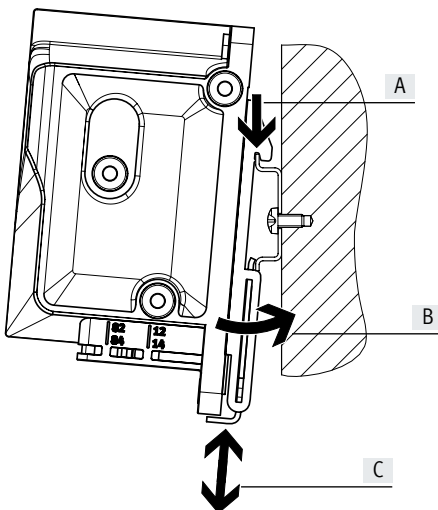

The valve terminal VTUX is attached to the H-rail (see arrow A). The valve terminal VTUX is then swivelled onto the H-rail (see arrow B). As a third step, the valve terminal VTUX is fixed on the H-rail by moving the slide on the H-rail mounting (see arrow C).

The clamping kit for H-rail mounting enables the valve terminal to be mounted on H-rails to EN 60715.

**Note**

The clamping kit locks the valve terminal in a horizontal mounting position.

Key features – Mounting

Tie rod

Configuration

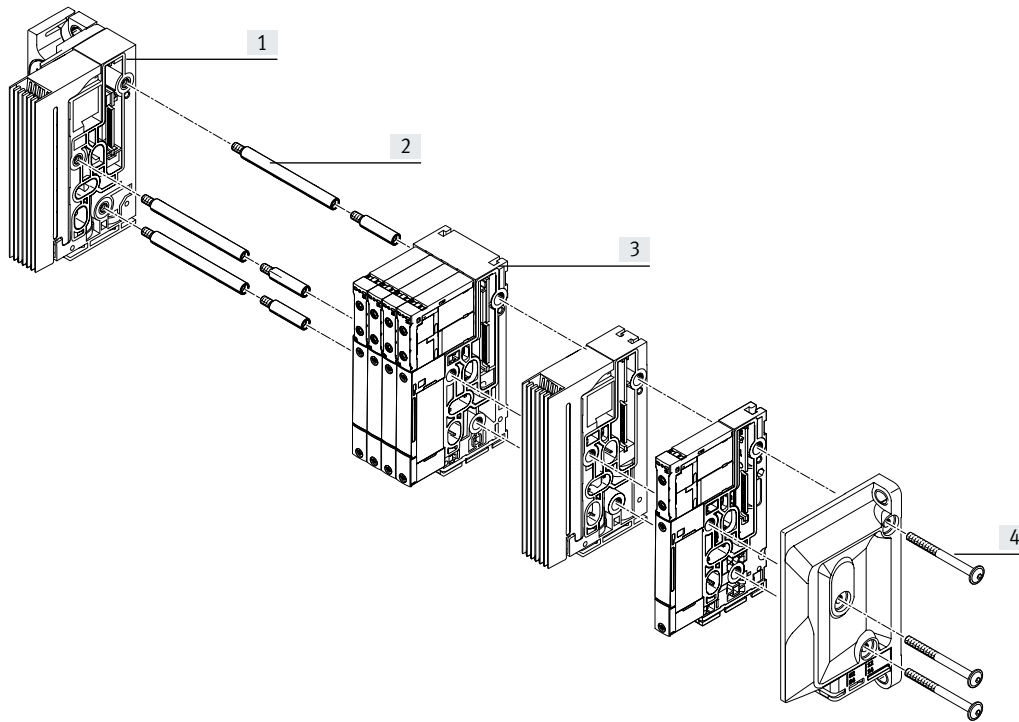

- [1] Left end plate
- [2] Tie rod sections
- [3] Manifold sub-bases
- [4] Tie rod screws

Operating mode

The tie rod on the VTUX is made up of two parts:

- Threaded rods
- Screw

This enables valve terminals of any length to be created. It takes just four steps to assemble the tie rod and the valve terminal:

- Screw the threaded rods into the left end plate
- Push the sub-bases and supply modules onto the threaded rods
- Push on the right end plate and secure using the screws

The tie rod enables the valve terminal to be extended at a later date. This is done by loosening the tie rod screws and disassembling the relevant components. The additional sub-base or the additional supply module is inserted at the required location. The previously disassembled components are then re-assembled.

To compensate for the change in length, the tie rod must be extended by the increase in length. To do this, threaded rods of a suitable length are screwed in place. To determine which components are required, the online spare parts catalogue includes information on how to use the spare parts and a conversion guide.

Tie rod – Components and design

Tie rod (threaded rod)



The threaded rod is used to create a cost-optimised fixed-grid tie rod. The combination of a threaded rod and screw offers the optimum compensation of tolerances (by compressing the seals between the manifold sub-bases).

The valve terminal can be extended almost infinitely at any time using additional threaded rod sections. The threaded rod sections are inserted between the existing threaded rod and are available in different lengths, in each case matched to the manifold sub-bases and supply modules.

Screw



The entire valve terminal is clamped via the tie rod using the screw.

Tolerances that occur, for example when the seals are compressed between the manifold sub-bases during assembly, are compensated by the interaction of the screw and the threaded rod.

Key features – Mounting

Ordering data – Tie rods				
Reference length [mm]	Part no.	Type	Part no.	Type
L = sum of the widths of the manifold sub-bases and supply modules	Tie rod		Screw	
21.00 ... 23.00	–	–	8191748	VAME-XA-S-M4-45
25.00 ... 29.60	8191756	VAME-XA-Z-19	8191747	VAME-XA-S-M4-30
31.50 ... 38.80	8191757	VAME-XA-Z-29	8191747	VAME-XA-S-M4-30
40.00 ... 63.30	8191758	VAME-XA-Z-38	8191748	VAME-XA-S-M4-45
63.40 ... 86.20	8191761	VAME-XA-Z-61	8191748	VAME-XA-S-M4-45
86.30 ... 109.10	8191762	VAME-XA-Z-84	8191748	VAME-XA-S-M4-45
109.20 ... 131.80	8191763	VAME-XA-Z-107	8191748	VAME-XA-S-M4-45
131.90 ... 154.30	8191764	VAME-XA-Z-130	8191748	VAME-XA-S-M4-45
154.40 ... 173.70	8191765	VAME-XA-Z-150	8191748	VAME-XA-S-M4-45
173.80 ... 193.20	8191766	VAME-XA-Z-170	8191748	VAME-XA-S-M4-45
193.30 ... 212.70	8191767	VAME-XA-Z-190	8191748	VAME-XA-S-M4-45

Key features – Display and operation

Display and operation

Signal status indication

Every solenoid coil is allocated an LED that indicates its signal status.

- Indicator 12 shows the signal status of the coil for duct 2
- Indicator 14 shows the signal status of the coil for duct 4

Manual override

The manual override (MO) enables the valve to be switched when not electrically actuated or energised.

The valve is switched by pushing the manual override.

Alternatives:

- A cover cap (code HR or as an accessory) can be used to operate the manual override in detenting mode.
- A cover cap (code HV or as an accessory) can prevent the manual override from being accidentally activated.

Pneumatic connection and control elements

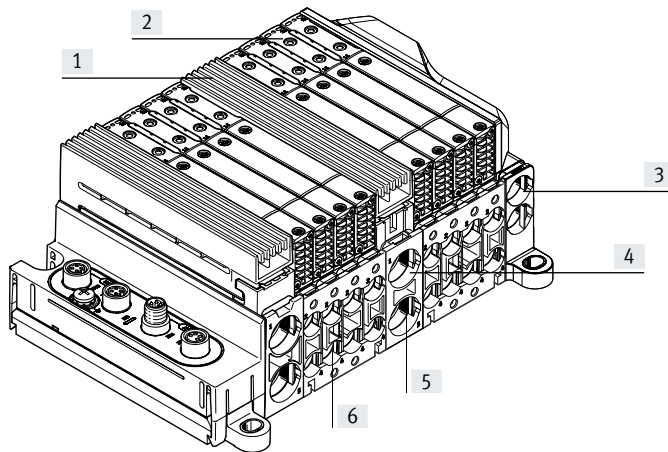

- [1] Flat plate silencer, duct 3/5
- [2] Manual override (for each pilot solenoid, non-detenting or non-detenting/detenting)
- [3] Ports 12/14 for external pilot air supply and 82/84 for pilot exhaust air in the right end plate
- [4] Supply port, duct 1
- [5] Ducted exhaust air, duct 3/5
- [6] Working ports, ducts 2 and 4, for each valve position

 **Note**

A manually actuated valve (using the manual override) cannot be reset electrically.

Conversely, an electrically actuated valve cannot be reset using the manual override.

Manual override

Manual override with automatic return (non-detenting)

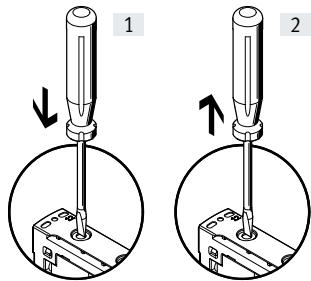

- [1] Press in the plunger of the manual override with a pointed object or screwdriver. The pilot valve switches and actuates the main valve.
- [2] Remove the pointed object or screwdriver. The spring force pushes the plunger of the manual override back. The pilot valve returns to the normal position as does the single solenoid main valve (this is not the case with a double solenoid valve).

Cover cap for manual override, mounting

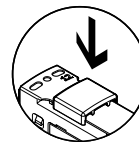

Clip the covering onto the pilot valve.

Manual override with cover cap, detenting without accessories, actuation

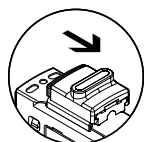

- Moving the slide on the cover cap in the direction of the arrow results in:
- The slide locks into the end position
 - The pilot valve switches and actuates the main valve

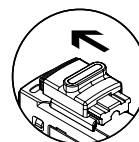

- Moving the slide on the cover cap in the direction of the arrow results in:
- The slide locks into the end position
 - The spring force pushes the plunger of the manual override back.
 - The pilot valve returns to the normal position as does the single solenoid main valve (this is not the case with a double solenoid valve).

Key features – Electrical components

Electrical connection – Left end plate

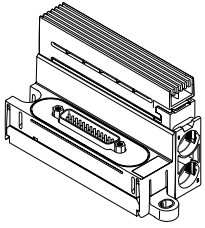

The electrical connection from the valves to a higher-order controller is in the left end plate of the VTUX.

Switching between the various connection options is easy: simply swap the left end plate. The pneumatic connections remain unaffected.

The valves are switched by positive or negative logic (PNP or NPN). Mixed operation is not permitted.

Guidelines on addressing for valves/solenoid coils

The addresses are numbered from left to right in ascending order. The following applies for individual valve positions: address x for coil 14 and address $x+1$ for coil 12.

Every manifold sub-base occupies a specific number of addresses/pins:

- Manifold sub-base for a single-solenoid valve: 1
- Manifold sub-base for a double-solenoid valve: 2
- Manifold sub-base for four single solenoid valves: 4
- Manifold sub-base for four double solenoid valves: 8

**Note**

If a single solenoid valve is mounted on a double solenoid valve position, the second address (for coil 12) is also occupied and cannot be used.

Key features – Electrical components

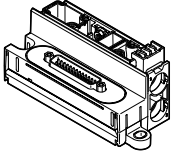
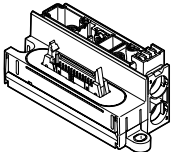
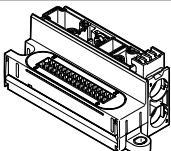
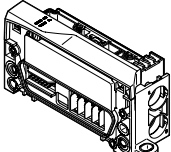
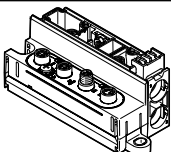
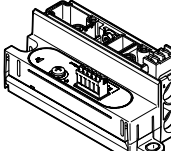
Variants of the left end plate					
	Code	Type	Max. number of addresses	Degree of protection	Information
Electrical multi-pin plug connection					
	Electrical connection: MS1	VABX-A-P-EL-E12-MS1	24	IP40	Electrical connection: Sub-D, 25-pin
	Electrical connection: MS3	VABX-A-P-EL-E12-MS3	32	IP40	Electrical connection: Sub-D, 44-pin
	Electrical connection: MS6	VABX-A-P-EL-E12-MS6	24	IP65	Electrical connection: Sub-D, 25-pin
	Electrical connection: MS8	VABX-A-P-EL-E12-MS8	32	IP65	Electrical connection: Sub-D, 44-pin
	Electrical connection: MF1	VABX-A-P-EL-E12-MF1	24	IP40	Electrical connection: ribbon cable, 26-pin
	Electrical connection: MC	VABX-A-P-EL-E12-MC	32	IP40	Electrical connection: terminal strip, 34-pin
Fieldbus interface/automation system CPX-AP-A					
	Electrical connection: APA	VABX-A-P-EL-E12-APA	32	IP65	Electrical connection: CPX-AP-A link
Interface to automation system CPX-AP-I					
	Electrical connection: API	VABX-A-P-EL-E12-API	32	IP65	Electrical connection <ul style="list-style-type: none"> • 2x socket, M8x1, D-coded, 4-pin, AP-COM • M8x1, A-coded, 4-pin for power supply
IO-Link® interface					
	Electrical connection: IOL	VABX-A-P-EL-E12-IOL	32	IP40	Electrical connection: Push-in, IO-Link®
	Electrical connection: IOS	VABX-A-P-EL-E12-IOS	32	IP65	Electrical connection: M12, IO-Link®

Key features – Electrical components

Fieldbus interface/automation system CPX-AP-A

The pneumatic interface (left end plate) serves as an adapter between the two current feeds. All functions and features of the automation system CPX-AP-A are valid in combination with the CPX-AP-A interface.

This means that:

- The valves and outputs are supplied via the system supply for the automation system CPX-AP-A

- The valves can optionally be actuated or switched off separately from the outputs

 **Note**
More information can be found at:
→ Internet: cpx-ap-a

Automation system CPX-AP-I

All functions and features of the CPX-AP-I are valid in combination with the automation system CPX-AP-I:

- Power supply via the connection in the left end plate of the VTUX

- Power supply together with other modules or individually for the valve terminal
- Valves actuated via the communication cable from the preceding module

- Cable length of up to 50 m between the modules
- Up to 80 individual modules/valve terminals per bus interface

 **Note**
More information can be found at:
→ Internet: cpx-ap-i

IO-Link®

The IO-Link® interface enables the valve terminal VTUX to be connected to the following systems:

- Automation systems CPX-AP-A, CPX-AP-I and CPX-E from Festo
- CPX terminal
- Control system CECC
- Bus node CTEU from Festo
- IO-Link® master

The maximum distance between the IO-Link® master and valve terminal with IO-Link® interface is 20 m.

The 5-pin connecting cables transmit the power supply for the valves; the power supply for the internal valve terminal electronics and the control signals are separate from this.

 **Note**
More information can be found at:
→ Internet: cteu

Instructions for use

Operating materials

Operate your system with unlubricated compressed air, if possible. Festo valves and cylinders are designed so that, if used as intended, they will not require additional lubrication and will still achieve a long service life. The quality of compressed air downstream of the compressor must correspond to that of unlubricated compressed air. If possible, do not operate the entire system with lubricated compressed air. The lubricators should, where possible, always be installed directly upstream of the actuator requiring them.

Incorrect additional oil and too high an oil content in the compressed air reduce the service life of the valve terminal. Use Festo special oil OFSW-32 or the alternatives listed in the Festo catalogue (as specified in DIN 51524 HLP32; basic oil viscosity 32 CST at 40°C).



Bio-oils

When using bio-oils (oils which are based on synthetic or native esters, e.g. rapeseed oil methyl ester), the maximum residual oil content of 0.1 mg/m³ must not be exceeded (see ISO 8573-1 Class 2).

Mineral oils

When using mineral oils (e.g. HLP oils to DIN 51524, parts 1 to 3) or similar oils based on poly-alpha-olefins (PAO), the maximum residual oil content of 5 mg/m³ must not be exceeded (see ISO 8573-1 Class 4). A higher residual oil content is not permitted, regardless of the compressor oil, because the permanent lubrication would otherwise be flushed out over a period of time.

Datasheet – Valve terminal VTUX

-  - Flow rate
to 670 l/min
-  - Valve width
10 mm
-  - Voltage
24 V DC

**General technical data**

Valve terminal design	Modular and expandable	
Actuation type	Electrical	
Nominal operating voltage	[V DC]	24
Permissible voltage fluctuations	[%]	±10
Max. no. of valve positions	32	
Max. no. of pressure zones	32	
Valve size	[mm]	10
Type of control	Piloted	
Valve function	2x3/2-way, single solenoid, closed	
	2x3/2-way, single solenoid, open	
	5/2-way, single solenoid	
	5/2-way, double solenoid	
	5/3-way, closed	
Design	Piston spool	
Sealing principle	Soft	
Type of mounting, sub-base	Via through-hole	
Type of mounting	Tie rod	
Pilot air supply	Internal or external	
Suitable for vacuum	Yes	
Exhaust air function	Can be throttled	
Standard nominal flow rate	[l/min]	470 ... 670
Grid dimension	[mm]	10.55 ... 12.55

Pneumatic connections

Pneumatic connection	1	-	-	QS-8	QS-10	QS-12	-	-	-	QS-5/16	QS-3/8	-
	3	-	-	QS-8	QS-10	QS-12	-	-	-	QS-5/16	QS-3/8	Silencer
	5	-	-	QS-8	QS-10	QS-12	-	-	-	QS-5/16	QS-3/8	Silencer
	12/14	QS-4	QS-6	QS-8	-	-	-	-	QS-1/4	QS-5/16	-	Silencer
	82/84	QS-4	QS-6	-	-	-	-	-	QS-1/4	QS-5/16	-	Silencer
	2	-	QS-6	QS-8	-	-	QS-1/8	QS-5/32	QS-1/4	QS-5/16	-	-
	4	-	QS-6	QS-8	-	-	QS-1/8	QS-5/32	QS-1/4	QS-5/16	-	-

Datasheet – Valve terminal VTUX

Operating and environmental conditions		
Operating medium		Compressed air to ISO 8573-1:2010 [7:4:4] → 37
Pilot medium		Compressed air to ISO 8573-1:2010 [7:4:4] → 37
Operating pressure	[MPa]	-0.1 ... +0.7
	[bar]	-1 ... +7
	[psi]	-14.5 ... +101.5
Operating pressure for valve terminal with internal pilot air supply	[MPa]	0.15 ... 0.7
	[bar]	1.5 ... 7
	[psi]	21.75 ... 101.5
Pilot pressure	[MPa]	0.15 ... 0.7
	[bar]	1.5 ... 7
	[psi]	21.75 ... 101.5
Ambient temperature	[°C]	-5 ... +50
Storage temperature	[°C]	-20 ... +70
Maximum setup altitude	[m]	3500
Corrosion resistance class CRC ¹⁾		1
CE marking (see declaration of conformity)		To EU EMC Directive ²⁾
		To EU RoHS Directive ²⁾
UKCA marking (see declaration of conformity)		To UK EMC regulations ²⁾
		To UK RoHS regulations ²⁾
KC marking		KC EMC
Certification		RCM
Vibration resistant		Transport application test with severity level 2 to FN 942017-4 and EN 60068-2-6
Shock resistance		Shock test with severity level 2 to FN 942017-5 and EN 60068-2-27
Continuous shock resistance to DIN/IEC 68, Part 2 - 82		Tested to severity level 1
Degree of protection		IP65, IP6X



1) More information www.festo.com/x/topic/crc

2) For information about the area of use, see the EC declaration of conformity at: www.festo.com/catalogue/... → Support/Downloads.

If the devices are subject to usage restrictions in residential, commercial or light-industrial environments, further measures for the reduction of the emitted interference may be necessary.

Materials	
Manifold sub-base	PA
Seals	NBR
	HNBR
Note on materials	RoHS-compliant
LABS (PWIS) conformity	VDMA24364-C1-L

Datasheet – Valves of size 10 mm

-  Flow rate
to 730 l/min
-  Valve size
10 mm
-  Voltage
24 V DC

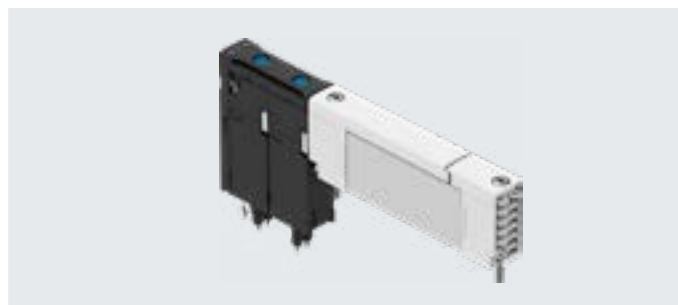
**General technical data**

Valve size	10 mm
Design	Piston slide with sealing ring
Actuation type	Electrical
Type of control	Piloted
Duty cycle [%]	100
Electrical connection	Plug-in
Pilot air supply	External
Sealing principle	Soft
Exhaust air function	Can be throttled
Manual override	Non-detenting
Signal status indication	Yes
Mounting position	Any
Type of mounting	On sub-base
Width [mm]	10.35

Pneumatic connections

Pneumatic connection	1	Sub-base
	3	Sub-base
	5	Sub-base
	12	Sub-base
	82	Sub-base
	2	Sub-base
	4	Sub-base

Technical data – Valves

Code for position function 1-64	A	M	J	NS	K	KC	G	
Valve function	5/2-way, single solenoid		5/2-way, double solenoid	2x3/2-way, single solenoid, open	2x3/2-way, single solenoid, closed		5/3-way, closed	
Reset method	Mechanical spring	Pneumatic spring	–	Mechanical spring	Mechanical spring	Pneumatic spring	Mechanical spring	
Overlap	Negative overlap						Positive overlap	
Flow direction	Reversible	Not reversible	Reversible with restrictions	Reversible	Reversible	Not reversible	Reversible	
Switching times [ms]	≤34.5	≤18.4	≤10.4	≤17.3	≤17.3	≤21.9	≤48.3	
Nominal flow rate standardised according to ISO 8778 [l/min]	730	730	730	555	600	600	510	
Nominal flow rate standardised according to ISO 8778, exhaust 2→3 [l/min]	700	700	700	545	650	650	465	
Operating pressure	[MPa]	–0.09 ... +0.7	0.2 ... 0.7	–0.09 ... +0.7	0.0 ... 0.7	0.0 ... 0.7	0.15 ... 0.7	–0.09 ... +0.7
	[bar]	–0.9 ... +7	2 ... 7	–0.9 ... +7	0 ... 7	0 ... 7	1.5 ... 7	–0.9 ... +7
Pilot pressure	[MPa]	0.25 ... 0.7	0.2 ... 0.7	0.15 ... 0.7	0.15 ... 0.7	0.15 ... 0.7	0.15 ... 0.7	0.15 ... 0.7
	[bar]	2.5 ... 7	2 ... 7	1.5 ... 7	1.5 ... 7	1.5 ... 7	1.5 ... 7	1.5 ... 7
Product weight [g]	41.5	41.3	49.7	50.7	50.7	49.9	51.1	

Datasheet – Valves of size 10 mm

Operating and environmental conditions		
Operating medium	Compressed air to ISO 8573-1:2010 [7:4:4] → 37	
Pilot medium	Compressed air to ISO 8573-1:2010 [7:4:4] → 37	
Note on the operating/pilot medium	Lubricated operation possible (in which case lubricated operation will always be required)	
Ambient temperature [°C]	-5 ... +50	
Temperature of medium [°C]	-5 ... +50	
Storage temperature [°C]	-20 ... +70	
Burst pressure	[MPa]	3.5
	[bar]	35
	[psi]	507.5
Overload pressure	[MPa]	1
	[bar]	10
	[psi]	145
Corrosion resistance class CRC ¹⁾	1	
Vibration resistant	Transport application test with severity level 2 to FN 942017-4 and EN 60068-2-6	
Shock resistance	Shock test with severity level 1 to FN 942017-5 and EN 60068-2-27	
Degree of protection	IP65, IP67, with plug socket, to IEC 60529	

1) More information www.festo.com/x/topic/crc

Materials	
Housing	Anodised wrought aluminium alloy
Spring	High-alloy stainless steel
Piston spool	POM
Screws	Stainless steel
Seals	HNBR
Dynamic seals	HNBR
Note on materials	RoHS-compliant
LABS (PWIS) conformity	VDMA24364-C1-L

Datasheet – Valves of size 10 mm

Pilot pressure p2 as a function of working pressure p1

For 5/2-way valve, single solenoid, mechanical spring return

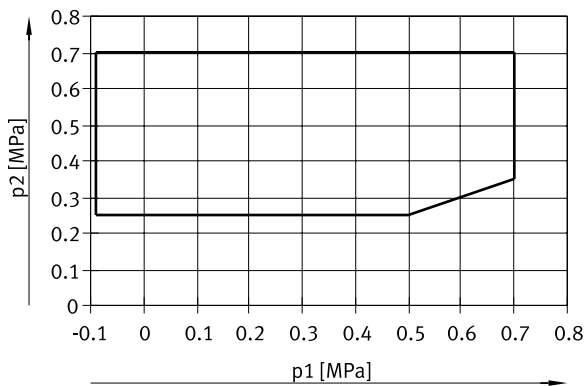

For 5/2-way valve, single solenoid, pneumatic spring return

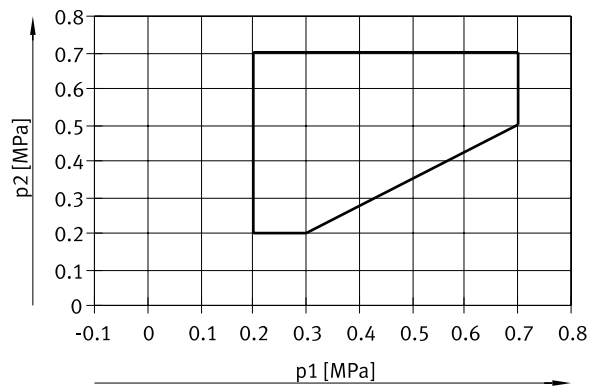

For 5/2-way valve, double solenoid

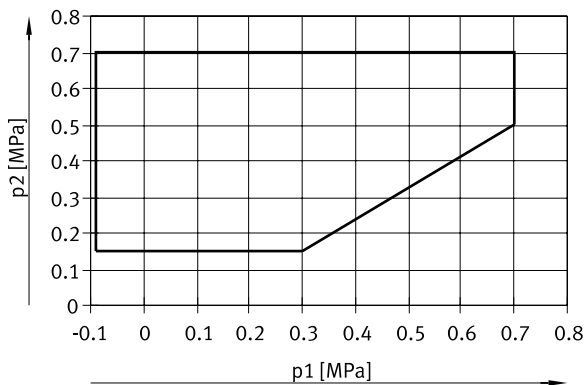

For 2x3/2-way valve, mechanical spring return

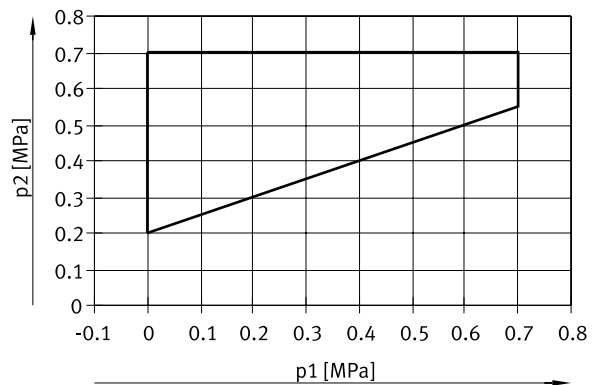

For 2x3/2-way valve, pneumatic spring return

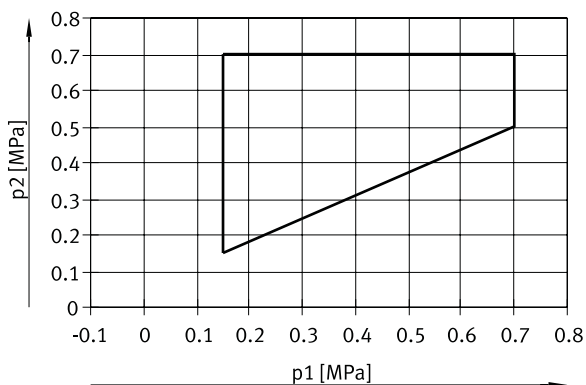

For 5/3-way valve, normally closed

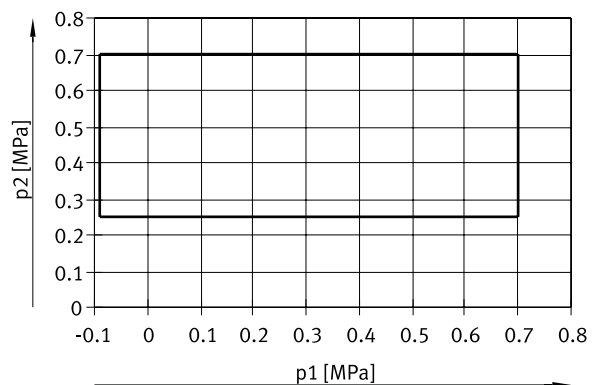

Datasheet – Manifold sub-bases

–  – Valve size
10 mm

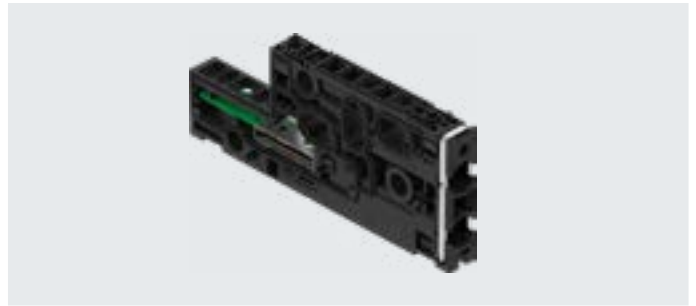

General technical data				
Type	VABX-A-P-BV-AH	VABX-A-P-BV-BH	VABX-A-P-BV-AH-R	VABX-A-P-BV-BH-R
Maximum number of valve positions	1	1	2	2
Dimensions W x L x H [mm]	10.55 x 104.3 x 43.1	12.55 x 104.3 x 43.1	42.05 x 104.3 x 43.1	50.05 x 104.3 x 43.1
Product weight [g]	31.2	36.2	115.7	136.2

Materials		
	For one valve	For four valves
Sub-base	Reinforced PA	Reinforced PA
Seals	NBR	NBR
Retainer	–	POM
Clamp	High-alloy stainless steel	High-alloy stainless steel
Nut	High-alloy stainless steel	High-alloy stainless steel
Note on materials	RoHS-compliant	RoHS-compliant
LABS (PWIS) conformity	VDMA24364-B1/B2-L	VDMA24364-B1/B2-L

Datasheet

Dimensions

Download CAD data → www.festo.com

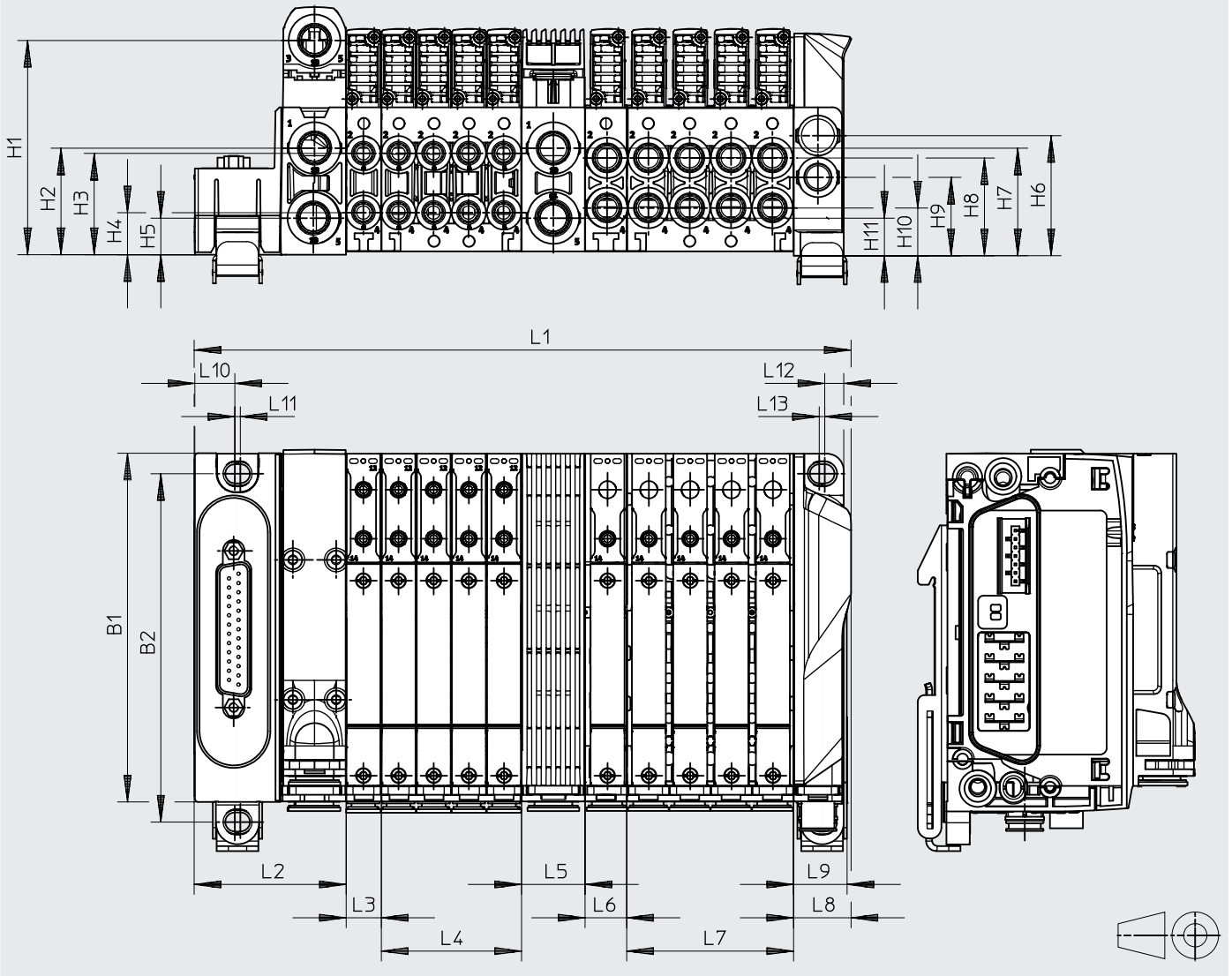

Type	B1	B2	H1	H2	H3	H4	H5	H6	H7	H8	H9	H10	H11
VTUX	104.6	104.5	64.3	32	30.4	12.6	11	36	32.3	29.3	23.5	14.3	11.3





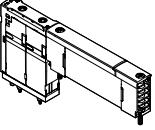
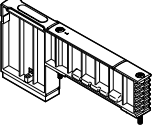
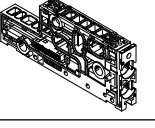
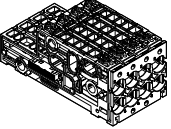
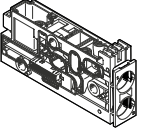
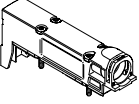
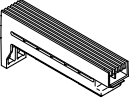

Type	L1	L2	L3	L4	L5	L6	L7	L8	L9	L10	L11	L12	L13
VTUX	$L2 + L8 + m \times L3 + n \times L4 + o \times L5 + p \times L6 + q \times L7$	45.7	10.5	42	19.1	12.5	50	17.2	16.1	12	1.7	5.7	1.7

1) m, n, o, p, q = number of manifold sub-bases/valve positions

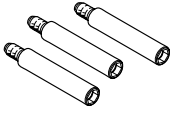
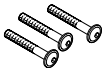
Accessories

Ordering data		Code	Valve function	Part no.	Type	
Individual solenoid valve – Valve size 10 mm						
	5/2-way valve					
	Position function 1-64: A	Single solenoid, mechanical spring return		8187057	VUVX-BK10-M52-MZH-F-1T1L	
	Position function 1-64: M	Single solenoid, pneumatic spring return		8187056	VUVX-BK10-M52-A1ZH-F-1T1L	
	Position function 1-64: J	Double solenoid		8187059	VUVX-BK10-B52-ZH-F-1T1L	
	2x 3/2-way valve					
	Position function 1-64: NS	Normally open, mechanical spring return		8187063	VUVX-BK10-T32U-MZH-F-1T1L	
	Position function 1-64: K	Normally closed, mechanical spring return		8187061	VUVX-BK10-T32C-MZH-F-1T1L	
	Position function 1-64: KC	Normally closed, pneumatic spring return		8187060	VUVX-BK10-T32C-A1ZH-F-1T1L	
	5/3-way valve					
Position function 1-64: G	Mid-position closed		8187066	VUVX-BK10-P53C-MZH-F-1T1L		
Vacant position – Valve size 10 mm						
	Position function 1-64: L	Cover plate for one valve position		8163948	VABB-XA-10-T	
Manifold sub-base – For one valve						
	–	Single solenoid (for 1 solenoid coil)	Cartridge	10 mm	8188458	VABX-A-P-BV-AH-F
				12 mm	8188462	VABX-A-P-BV-BH-G
		Double solenoid (for 2 solenoid coils)	Cartridge	10 mm	8188459	VABX-A-P-BV-AH-A
				12 mm	8188463	VABX-A-P-BV-BH-B
Manifold sub-base – For four valves						
	–	Single solenoid (for 1 solenoid coil)	Cartridge	10 mm	8188460	VABX-A-P-BV-AH-RVFFFF
				12 mm	8188464	VABX-A-P-BV-BH-RVGGGG
		Double solenoid (for 2 solenoid coils)	Cartridge	10 mm	8188461	VABX-A-P-BV-AH-RVAAAA
				12 mm	8188465	VABX-A-P-BV-BH-RVBBBB
Supply module						
	Connection position type 1-64: U	Manifold sub-base with ports for ducts 1 and 3/5, no plate, no cartridge		8191788	VABX-A-P-BU-E12-SHUH	
Plate						
	Position function 1-64: UD	Plate for ducted exhaust air, without cartridge, for mounting on supply module		8191794	VABF-XA-12-M2-QX	
	Position function 1-64: US	Exhaust plate, for mounting on supply module		8191741	VABF-XA-12-M1-C	

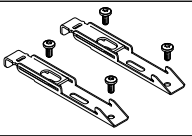

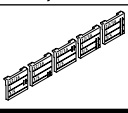
Accessories

Ordering data		Code	Description	Part no.	Type
Tie rods					
	Tie rod: –	Threaded rod for tie rod, internal hex, spanner size 4 The threaded rod/screw combination is selected based on the number and width of the individual sub-bases.	10 mm	8191752	VAME-XA-Z-10
			12 mm	8191753	VAME-XA-Z-12
			15 mm	8191754	VAME-XA-Z-15
			17 mm	8191755	VAME-XA-Z-17
			19 mm	8191756	VAME-XA-Z-19
			29 mm	8191757	VAME-XA-Z-29
			38 mm	8191758	VAME-XA-Z-38
			42 mm	8191759	VAME-XA-Z-42
			50 mm	8191760	VAME-XA-Z-50
			61 mm	8191761	VAME-XA-Z-61
			84 mm	8191762	VAME-XA-Z-84
			107 mm	8191763	VAME-XA-Z-107
			130 mm	8191764	VAME-XA-Z-130
			150 mm	8191765	VAME-XA-Z-150
			170 mm	8191766	VAME-XA-Z-170
	–	M4 screw with internal hex, spanner size 2.5, for tie rod	30 mm	8191747	VAME-XA-S-M4-30
			45 mm	8191748	VAME-XA-S-M4-45
Separator					
	–	Separator for pressure zone separation in duct 1		8191736	VABD-XA-12-P1
	–	Separator for pressure zone separation in duct 3/5		8191737	VABD-XA-12-P2
Wall mounting					
	–	Mounting bracket Wall brackets should be mounted on the valve terminal every 20 cm.		8191739	VAME-XA-W
H-rail mounting					
	Mounting accessories: H	Clamping kit for H-rail mounting		8191782	VAME-XA-H
Cover cap					
	Manual override: HV	Cover cap for manual override, concealed		8198864	VAMC-XA-CS
	Manual override: HR	Cover cap for manual override, detenting		8198865	VAMC-XA-CD
Inscription labels					
	–	Inscription label for marking pressure zone separation	Duct 1 separated	8191742	ASLR-C-XA-TT
			Duct 3/5 separated	8191743	ASLR-C-XA-TR
			Duct 1, 3/5 separated	8191745	ASLR-C-XA-TS

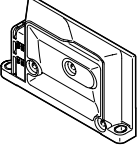
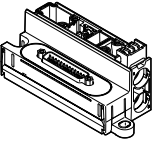
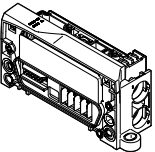
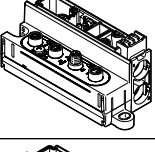
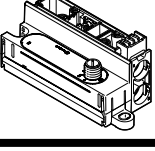
Accessories

Ordering data		Code	Description	Part no.	Type
Right end plate					
	-	With fastening holes for wall mounting		8191781	VABX-A-ER-E12-JHTH-XR
Left end plate					
	Electrical connection: MS1	Electrical interface for multi-pin plug connection, IP40	Sub-D, 25-pin, 24 addresses	8188447	VABX-A-P-EL-E12-MS1-SHUH
	Electrical connection: MS3		Sub-D, 44-pin, 32 addresses	8188449	VABX-A-P-EL-E12-MS3-SHUH
	Electrical connection: MF1		Ribbon cable, 26-pin, 24 addresses	8188451	VABX-A-P-EL-E12-MF1-SHUH
	Electrical connection: MC		Terminal strip, 34-pin, 32 addresses	8188452	VABX-A-P-EL-E12-MC-SHUH
	Electrical connection: MS6	Electrical interface for multi-pin plug connection, IP65	Sub-D, 25-pin, 24 addresses	8188448	VABX-A-P-EL-E12-MS6-SHUH
	Electrical connection: MF8		Sub-D, 44-pin, 32 addresses	8188450	VABX-A-P-EL-E12-MS8-SHUH
	Electrical connection: APA	Pneumatic interface for automation system CPX-AP-A, IP65	32 addresses	8189594	VABX-A-P-EL-E12-APA-SHUH
	Electrical connection: API	Pneumatic interface for automation system CPX-AP-I, IP65	32 addresses	8189592	VABX-A-P-EL-E12-API-SHUH
	Electrical connection: IOL	Node with IO-Link®, IP40	Push-in, 32 addresses	8189591	VABX-A-P-EL-E12-IOL-SHUH
	Electrical connection: IOS	Node with IO-Link®, IP65	M12, 32 addresses	8189590	VABX-A-P-EL-E12-IOS-SHUH

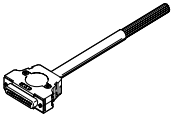
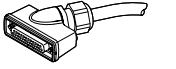
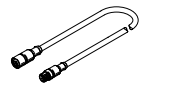
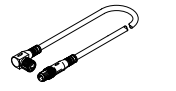
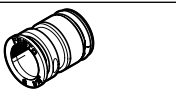
Accessories

Ordering data							
	Code	Description		Part no.	Type		
Connecting cable for multi-pin plug connection, Sub-D							
	-	Socket, 25-pin, straight, open cable end 25-pin	IP65/IP67	2.5 m	538225	NEBV-S1G25-K-2.5-N-LE25	
				5 m	538226	NEBV-S1G25-K-5-N-LE25	
				10 m	538227	NEBV-S1G25-K-10-N-LE25	
			IP40	2.5 m	575417	NEBV-S1G25-K-2.5-N-LE25-S6	
				5 m	575418	NEBV-S1G25-K-5-N-LE25-S6	
				10 m	575419	NEBV-S1G25-K-10-N-LE25-S6	
	-	Socket, 25-pin, angled, open cable end, 25-pin	IP65/IP67	2.5 m	575423	NEBV-S1WA25-K-2.5-N-LE25-S9	
				5 m	575424	NEBV-S1WA25-K-5-N-LE25-S9	
				10 m	575425	NEBV-S1WA25-K-10-N-LE25-S9	
		Socket, 44-pin, angled, open cable end, 44-pin	2.5 m	575420	NEBV-S1WA44-K-2.5-N-LE44-S9		
			5 m	575421	NEBV-S1WA44-K-5-N-LE44-S9		
			10 m	575422	NEBV-S1WA44-K-10-N-LE44-S9		
Connecting cable – Round plug							
	-	Socket M12x1, 8-pin, plug M12x1, 4-pin	IP67	2 m	553575	NEBV-M12G8-K-2-M12G4	
				5 m	553576	NEBV-M12G8-K-5-M12G4	
	-	Socket M8x1, 4-pin, plug M8x1, 3-pin	IP65 IP67	2.5	562468	NEBV-M8W4L-E-2.5-M8G3	
				5	562469	NEBV-M8W4L-E-5-M8G3	
				10	562470	NEBV-M8W4L-E-10-M8G3	
Ordering data							
	Code	Description		Weight [g]	Pack size	Part no.	Type
Cartridge							
	-	Cartridge 10 mm, connection for tubing O.D.	4 mm	0.9	10	8174164	NPQX-D-PC10-Q4-P10
			6 mm	0.72	10	8174165	NPQX-D-PC10-Q6-P10
			1/8"	2	10	8184511	NPQX-D-PC10-T18-P10
			5/32"	0.9	10	8184509	NPQX-D-PC10-T532-P10
			1/4"	2.15	10	8184510	NPQX-D-PC10-T14-P10
		Cartridge 12 mm, connection for tubing O.D.	4 mm	1.24	10	8174166	NPQX-D-PC12-Q4-P10
			6 mm	1.2	10	8174167	NPQX-D-PC12-Q6-P10
			8 mm	0.92	10	8174168	NPQX-D-PC12-Q8-P10
			5/32"	1.24	10	8184512	NPQX-D-PC12-T532-P10
			1/4"	2.6	10	8184514	NPQX-D-PC12-T14-P10
		Cartridge 15 mm, connection for tubing O.D.	5/16"	0.92	10	8184513	NPQX-D-PC12-T516-P10
			8 mm	1.9	10	8174169	NPQX-D-PC15-Q8-P10
			10 mm	1.64	10	8174170	NPQX-D-PC15-Q10-P10
			12 mm	7.6	10	8174171	NPQX-D-PC19-Q12-P10
			5/16"	1.9	10	8184515	NPQX-D-PC15-T516-P10
		3/8"	10	10	8189810	NPQX-D-PC10-T38-P10	
Silencer							
	-	Silencer		0.7	-	8191740	AMTX-P-PC12
Blanking plug							
	-	Cartridge	1	-	-	8191749	NPQX-P-PC10
			0.8	-	-	8191750	NPQX-P-PC12
			1.6	-	-	8191751	NPQX-P-PC15