

Programmable Multi-Axis Controller

PMAC Series



- World's fastest* output speeds for extremely precise motion control
- Flexible function development capability to support more innovation
- Multi-vendor compatibility to help create the right system for your application

* Refers to the motion control performance of 16.6 μ s/1 axes or 50 μ s/8 axes (Omron survey as of July 2016).

More flexible, more open Programmable Multi-Axis Controller ("PMAC")

Omron keeps believing in creative potential

In order to satisfy diverse consumer needs and deal with short product life cycles, manufacturers need to boost both their productivity and their manufacturing quality. Omron helps them do so by adopting the latest precision machining and robotics technologies.

More open technology is necessary to help customers turn their ideas into reality and flexibly respond to future challenges. That's why Omron developed the Programmable Multi-Axis Controller (PMAC). The PMAC delivers world-leading* output speeds and flexibility that allows you to achieve your vision with unhindered creativity. Turn your ideas into a real machine and enrich the lives of people around the world through products that it produces.

The PMAC was originally created by Delta Tau Data Systems, Inc., which joined the Omron family in September 2015. It was further developed by incorporating Omron's philosophy and technology to give it potential that has no limits.

* Refers to the motion control performance of 16.6 μ s/1 axes or 50 μ s/8 axes (Omron survey as of July 2016).

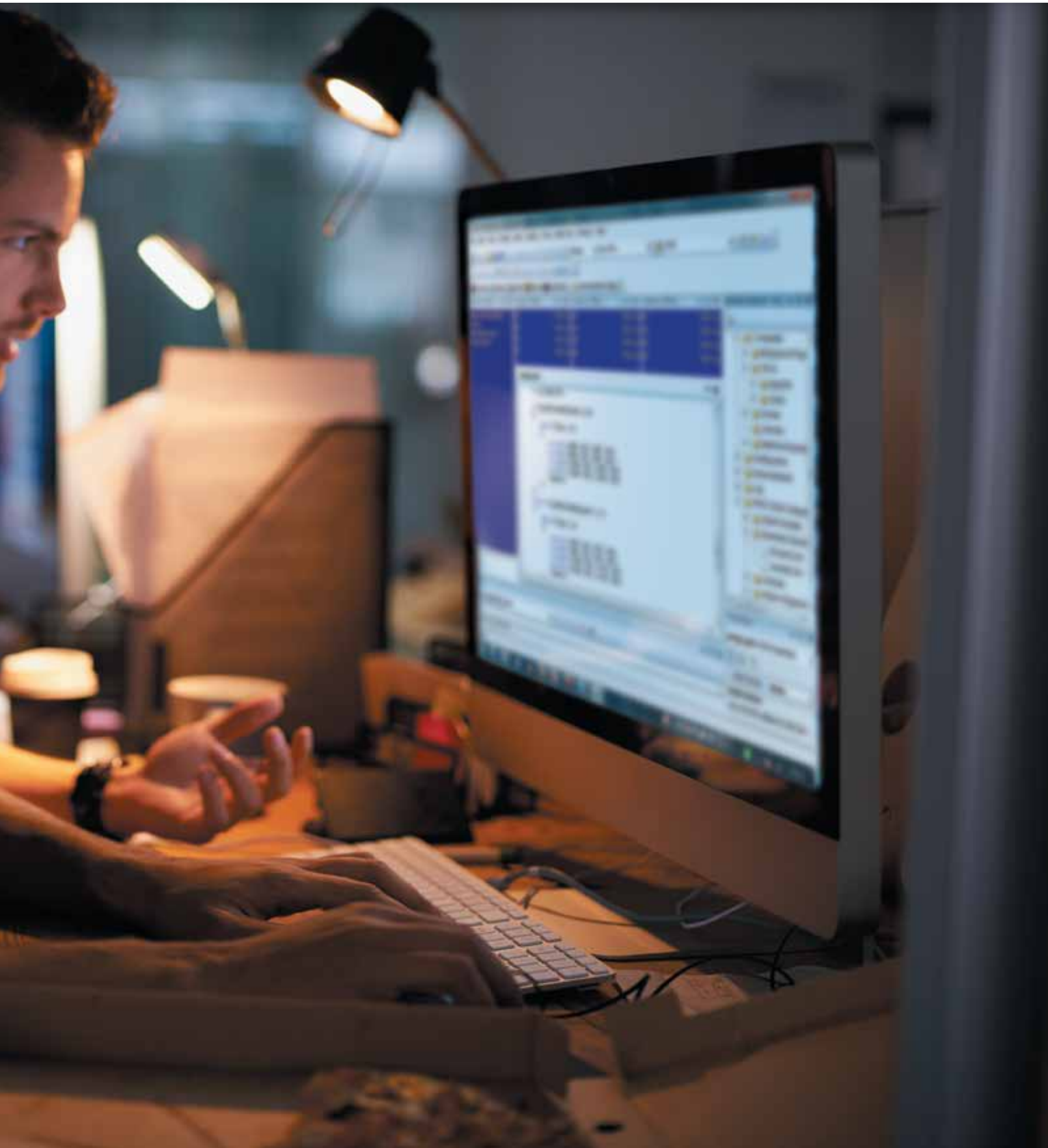

Control innovation with ultra-high-speed calculations

The Programmable Multi-Axis Controller (PMAC) is a controller designed specifically for high-precision, multi-axis motion control applications. Delivering world-leading* output speeds to perform precise linear motor drive control and nanometer positioning, the PMAC is appreciated by manufacturers of semiconductor manufacturing equipment and other products employing leading-edge technologies.

* Refers to the motion control performance of 16.6 μ s/1 axes or 50 μ s/8 axes (Omron survey as of July 2016).

Ultra-high-speed, high-precision

The PMAC achieves full closed loop control of position, velocity, torque, and current every servo cycle time of 16.6 μ sec/8 axis (Quad Core UMAC CPU).

High-speed execution of motion programs, PLC programs, trajectory generation, and position compensation improves positioning accuracy and velocity stability. The high-performance CPU centralizes the control of multiple axes to synchronize them precisely.

Flexible function development capability

The PMAC can be programmed in G-Code, ANSI C or original programming languages, offering flexibility to create your own control programs. You can use servo algorithms that you designed using MATLAB®, add the program synchronized with PID control, and control your own mechanical system to unlock your creativity.

Compatibility

You can configure a system to suit your application by connecting to both Omron devices and devices from other vendors. The PMAC can interface with virtually any type of motor, including ultrasonic and voice coil motors, and can give position, velocity and torque commands as well as commutation commands (two-phase analog commands and direct PWM commands) to the connected motors. It can also give Galvano scanner commands.

The PMAC provides various input and feedback interface capabilities to accept the A/B phase signals, 1Vp-p sine wave signals from linear encoders, and parallel binary signals from serial data interfaces and laser interferometers.

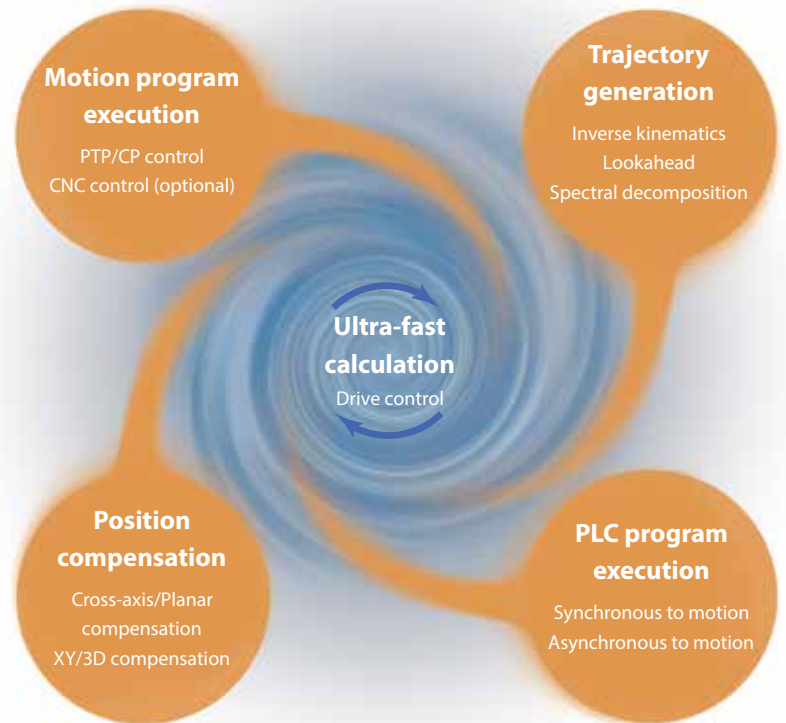

Innovative control applications

The PMAC allows you to develop advanced systems that integrate your own technologies. It works well for a variety of applications ranging from manufacturing sites to high-level academic studies.

Processing machines

The PMAC enables high-speed, high-precision processing for electric discharge machines, water jet machines, laser processing machines, plasma processing machines and ultra-precision machining systems.



Robots

The PMAC facilitates complex mechanical control for machines using customized robots.



Semiconductor/FPD manufacturing/inspection machines

The PMAC provides extremely precise motion for electron beam exposure machines, linear coaters, sealant dispensers and wafer inspection machines.

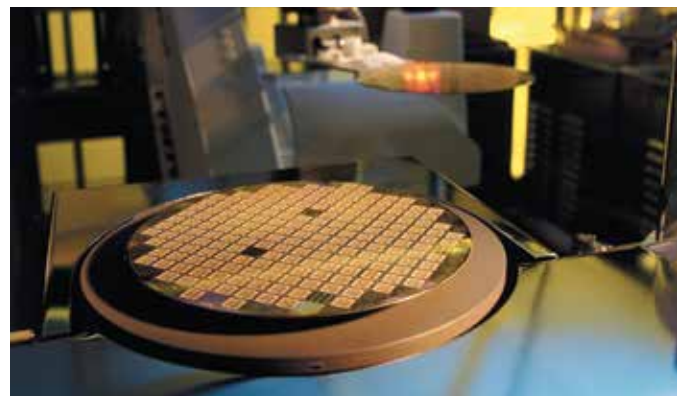

Academic studies

The PMAC ensures ultra-high-speed control functionality for undulators and monochromators in synchrotron systems.



Versatile motion functions to create the best machine

Motor control

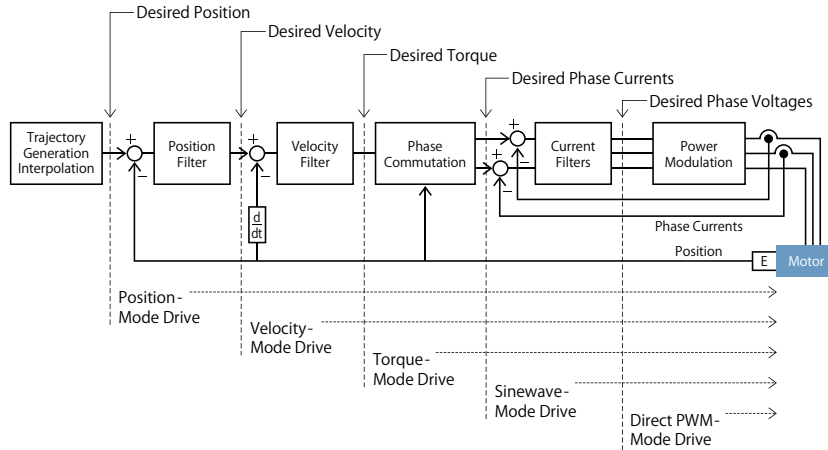

The PMAC has many modes for controlling motors: position-, velocity-, torque-, sinewave-, and direct PWM-mode drives. In addition to default servo algorithms, custom servo algorithms can be implemented. This enables motors to be fully synchronized even if many external devices are connected.

Automatically calculates position and velocity

Dynamic Lookahead

The PMAC algorithmically evaluates trajectories in advance of their execution. This optimized trajectory maximizes speed, acceleration and smoothness, reducing cycle time and improving path accuracy.

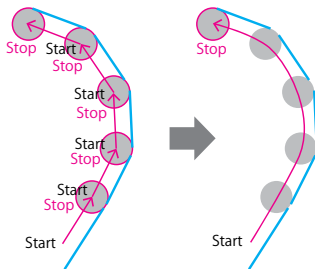

Positional Compensation

Table-based position compensation for imperfections in the mechanics enables more accurate motion.

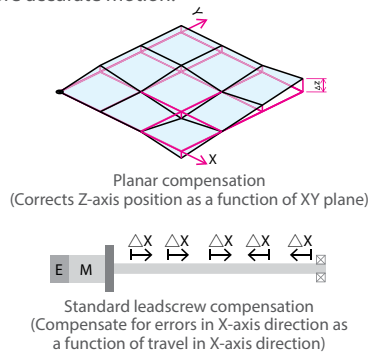

Forward/Inverse Kinematics

Write a kinematics calculation as a subroutine to control user-developed mechanical systems (e.g. robots). In addition to mechanical control, it can also convert the travel distance (velocity) of the laser scanning header into the laser pulse amount.

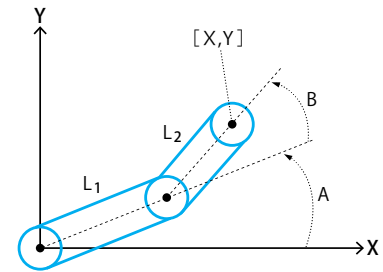

Precisely synchronizes axes

Motion Spectral Decomposition

A single trajectory is divided into separate components that the standard (e.g. XY stage) and fast-tool actuators (e.g. Galvano actuator) execute in coordinated fashion.

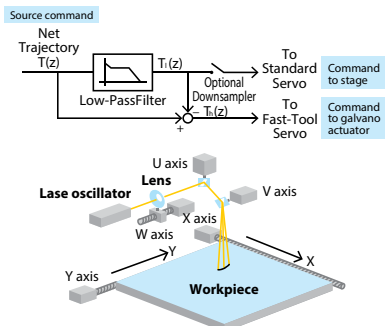

Ultra-fast Position-Compare

A hardware circuit creates an output pulse (response time: < 100 ns) when an exact encoder position is reached. Because it uses an actual position instead of a command, servo following errors do not affect the accuracy.

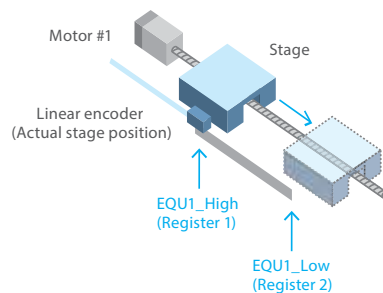

Cross-Coupled Gantry Control

Monitors in real time the positions of two gantry motors that have a tight mechanical linkage and corrects the skew between the motors to precisely synchronize the motion.

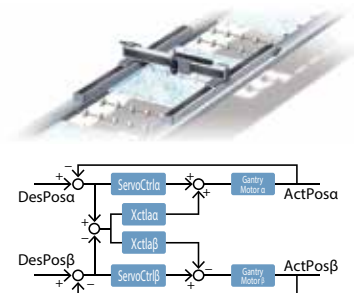

Creates motion profile

PVT Mode Contouring

Enables direct control over the trajectory profile created by combining trapezoidal and S-curve velocity profiles, achieving cycle time reduction and stability.

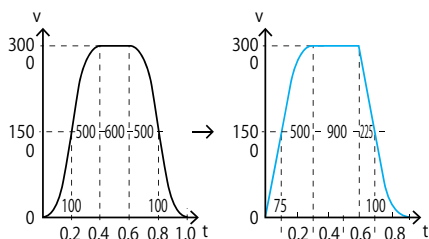

Spline Move Mode

Generates very smooth but complex profiles and contours. The time profiles are guaranteed to be continuous in position, velocity, and acceleration, even at move boundaries. Multi-dimensional paths are guaranteed continuous in position, direction, and curvature, even at move boundaries.

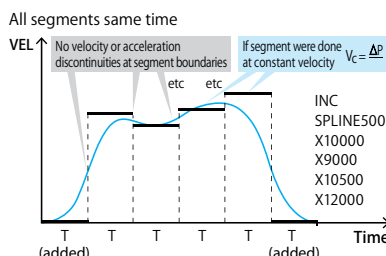

Move/Path Blending

Permits smooth transitions in centripetal acceleration when the radius/curvature changes, rather than the step change of unblended tangent moves. Linear-, circle-, and PVT-mode moves can be blended.

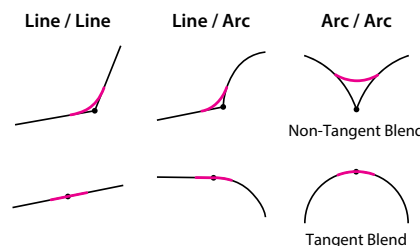

Suppresses disturbance

Torque Compensation

Provides velocity corrections by compensating for cyclic disturbances such as motor cogging torque.

Cogging torque

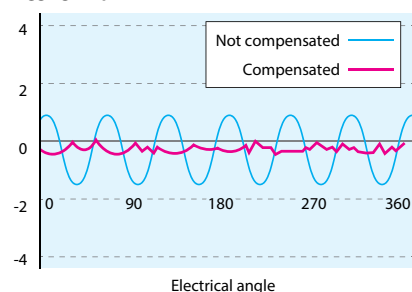

Trajectory Pre-Filter

Suppresses the occurrence of vibration by removing the resonant frequency with a trajectory pre-filter when sending a command.

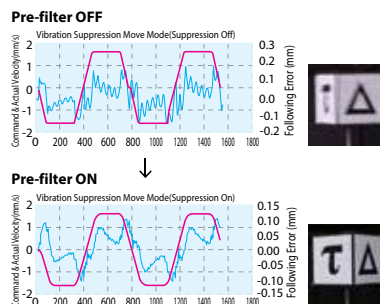

Adaptive Control

Automatically compensates for the load inertia changes to reproduce the intended motion.

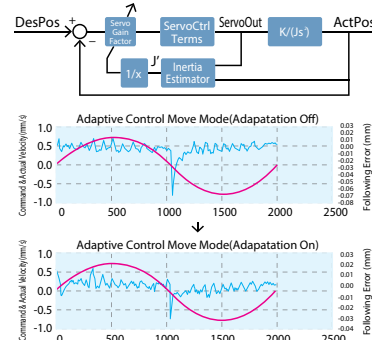

Executes motion program in synchronization with external input

Dual Feedback

Simultaneously uses velocity feedback from a servo and position feedback from a linear encoder or other device, providing extremely precise control (e.g. Bottom dead center control for high precision pressing machines).

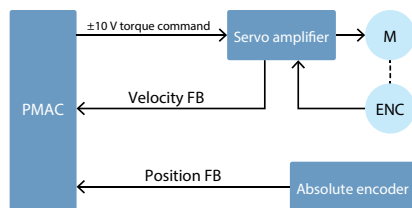

Cascaded Servo Loops

The output of one servo loop is used as an input to another servo loop, bringing the capabilities of both loops to bear on a single actuator. The coupling of the loops permits easy switching between control modes, e.g. from position control to load control when the target position is reached.

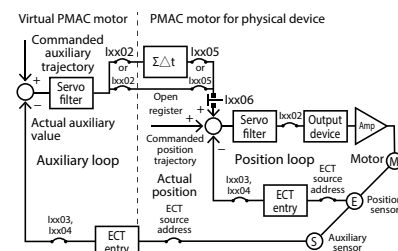

External Time Base Control

An electronic cam function can be created by executing a motion program, without using a cam table. The motion program is synchronized to an external axis, not to time. Multiple axes can be synchronized with workpiece feeding controlled by another controller, which is useful for thread cutting and pipe bending work.

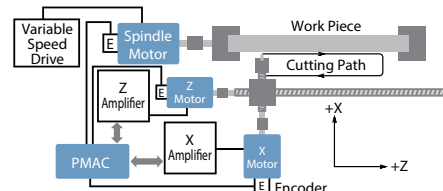

PMAC Series Product lineup

Motion controller plus PC, all in one box

Industrial Box PC
NY51□-A

2 in 1

Multi-axis motion controller equipped with a Windows Operating System.

Reliability

Hypervisor software for uninterrupted control even if Windows is down. Simplicity eliminates problem generation and improves reliability.

High performance

Controls up to 128 synchronized axes via EtherCAT® while running applications for creating high-resolution graphics and data handling



NY51□-A

Running on a Windows OS
 Up to 128 axes of control

Saving space in machines

Compact Controller
CK3E

Space-saving

Slim design of 28.6 mm saves space in machines and control panels

Cost-effective

High-speed, multi-axis control at an affordable cost (fastest cycle time of 250 μs)

Reduces wiring

One connection of servo drives, I/O and other devices via EtherCAT



CK3E-1□10

Main memory: 1 GB,
 flash memory: 1 GB
 1 x EtherCAT port,
 1 x Ethernet port

CK3M

Modular, flexible design

Din rail mounted CPU, axis modules and accessories.

CK3M-XPU1□1

Main memory: 1 GB, flash memory: 1 GB 1 x EtherCAT port, 1 x Ethernet port USB

Versatile

High-speed, multi-axis control expansion modules
 Powerful CPU's for demanding applications (fastest cycle time of 50 μs)

Ease of configuration

Modular design that is DIN rail mountable with no tools needed



System configuration using CK3E

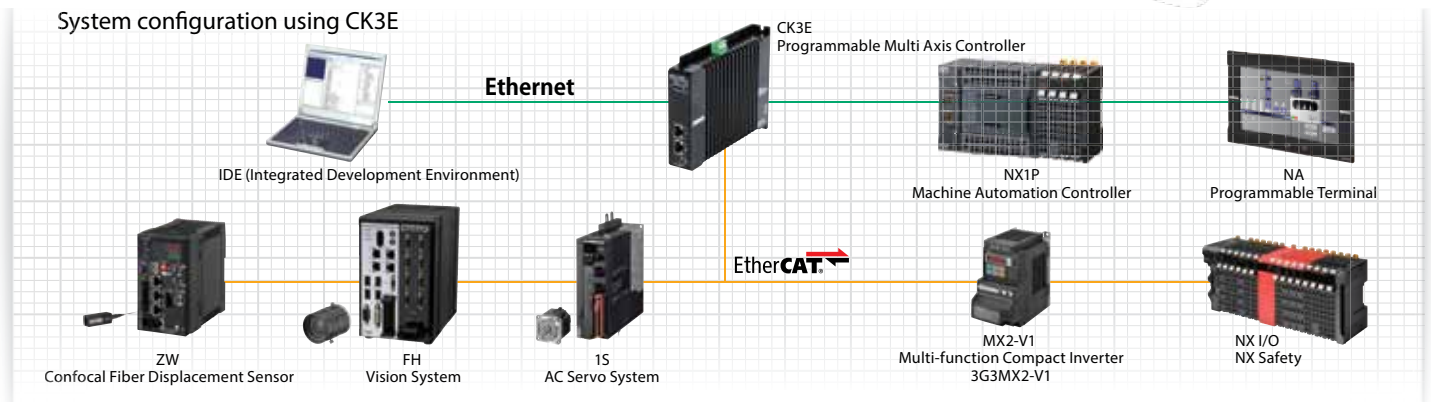

Powerful and scalable flagship controller

Modular Rack System Power UMAC

Customizable

Allows you to create a customer control system with exactly what you need for your application

Modular

Allows you to expand into multiple configurations for your control system and maintain commonality of hardware for each machine option

Flexible

Provides flexible connectivity and multiple communication methods, enabling you to take advantage of the most powerful and versatile machine control technology available



Power UMAC

1 GHz single-core or 1.2 GHz dual-core
Running on a Linux RTOS

Integrated multi-axis motion controller and amplifiers

Intelligent Amplifier Power Brick LV/AC

Integrated

A highly integrated package combining both the controller, amplifier and I/O

Convenient

Minimizes and simplifies your hardware and wiring in one system solution

Packaged

Integrated design allows for reduced cabinet space in a small, convenient package



Power Brick LV

4/8-axis
12-65 VDC (80 V option)



Power Brick AC

4/8-axis
240 VAC



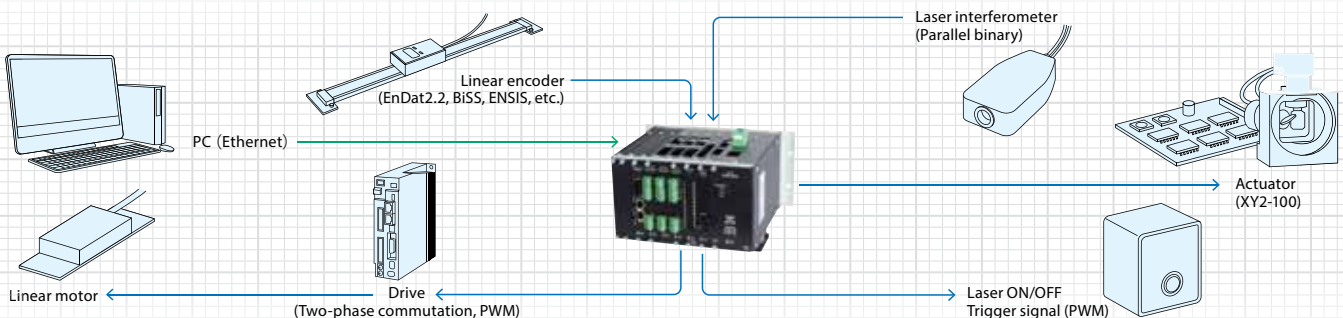

Note: Consult your Omron representative for details.

System configuration using Power UMAC: Laser marking machine



PMAC Series family

Specifications

Type		Industrial Box PC (IPC Programmable Multi Axis Controller)		Compact Controller (CK3E)	CK3M
Model		NY512-A600-1XX11391X	NY512-A600-1XX21391X	CK3E-1□10	CK3M□
Appearance					
Motion control	Max. no. of controlled axes	128		8, 16, 32	24
	Motion control period	250 μs or more			
	Control method	Issuing control commands using EtherCAT communications			PWM, Analog, EtherCAT
Interface	Ethernet port	●		—	Yes
	EtherCAT port	●		—	Yes
	MACRO port	—		—	—
	Analog I/O	—		—	Yes
	Digital I/O	—		—	Yes
	Feedback	—		—	Yes
Memory	RAM	8 GB		1 GB	1 GB
	Flash	—		1 GB	1 GB
	Storage	64 GB (SSD)		—	—
Windows OS	Windows Embedded Standard 7 32 bit	Windows Embedded Standard 7 64 bit	—	—	
Manufacturer	OMRON Corporation				



Software

Name	Application
Power PMAC IDE	Computer software to be used in configuring the controller, creating user programs, and debugging the programs.
EC-Engineer	Computer software to be used in configuring and monitoring the EtherCAT network by using the controller as the EtherCAT master. Bundled with Power PMAC IDE.
Power PMAC NC16	Power PMAC NC16 SDK Computer software to be used in controlling machine tools and other CNC machines with the controller and customizing HMI screens. Extension source codes used for customization are included.
	Power PMAC NC16 Runtime Computer software to be used in controlling machine tools and other CNC machines with the controller. Use this software when you do not customize the HMI screen.
Power PMAC Development Kit (PDK)	A collection of .Net Components and functions to be used in creating a .Net-based application program (HMI) that communicates to the controller.

Accessories for modular rack system (Power UMAC)

Digital I/O board			
ACC-65E	24 inputs/24 outputs, self-protected (overcurrent etc.) 12-24 VDC/PNP type/isolated Terminal block	ACC-67E	48 outputs, self-protected (overcurrent etc.) 12-24 VDC/PNP type/isolated Terminal block
	Option D-Sub 15 pin (female)		Option D-Sub 15 pin (female)
ACC-14E	48-bit input/output board 5 VDC	ACC-68E	24 inputs/24 outputs, self-protected (overcurrent etc.) 12-24 VDC/NPN type/isolated Terminal block
ACC-66E	48 inputs, sourcing, self-protected (overvoltage by Zener diode) 12-24 VDC/isolated Terminal block		Option D-Sub 15 pin (female)
	Option D-Sub 15 pin (female)		

Specifications

Modular Rack System (Power UMAC)	Intelligent Amplifier (Power Brick LV/AC)	
	Low voltage type (LV)	High voltage type (AC)
3-4045-□□□-□□□-□□-0□□	PBL□	PBA□
		
256	4, 8	4, 8
16.6 μs or more		
Available output accessories Analog (single-phase ±10 V) Pulse (pulse/direction) Two-phase analog (120° phase difference, ±10 V) Three-phase direct PWM	Built-in motor amplifiers	Built-in motor amplifiers
●		●
● (Optional board)		● (Option)
● (Optional board)		● (Option)
● (Optional board)		● (Option)
● (Optional board)		● (Option)
Available feedback accessories ABZ phase SIN/COS BiSS EnDat Omron 1S Serial encoders		Available feedback options ABZ phase SIN/COS BiSS EnDat Omron 1S Serial encoders
1 GB, 2 GB		1 GB, 2 GB
1 GB, 4 GB, 8 GB, 16 GB		1 GB, 4 GB, 8 GB
—		—
—		—
Delta Tau Data Systems, Inc		

Analog I/O board	
ACC-59E3	16 inputs 16-bit A/D converter Input range: ±10 V, 4-20 mA
	16 inputs 16-bit A/D converter Input range: ±10 V, 4-20 mA 8 inputs 16-bit DAC Output range: ±10 V
	16 inputs 16-bit A/D converter Input range: ±10 V, 4-20 mA 8 inputs 16-bit Output range: 4-20 mA
	16 inputs 16-bit A/D converter Input range: ±10 V, 4-20 mA 8 inputs 18-bit DAC Output range: ±10 V
	16 inputs 16-bit A/D converter Input range: ±10 V, 4-20 mA 8 inputs 18-bit Output range: 4-20 mA

Special field bus communication board	
ACC-72EX	Fieldbus interface
	DeviceNet - Master
	DeviceNet - Slave
	CANopen - Master
	CANopen - Slave
	EtherCAT - Master
	EtherCAT - Slave
EtherNet/IP™ - Scanner/Master	
EtherNet/IP™ - Adaptor/Slave	
Open Modbus/TCP	

Axis interface board	
ACC-24E3	2 or 4-axis digital amplifier (PWM) interface TB connector or DB-15 connector
ACC-24E3 Mezzanine Board	Digital feedback Analog feedback
Special encoder feedback	
ACC-51E	2-axis 4096x high-resolution analog encoder interpolator board
ACC-84E	UMAC universal serial encoder interface, XY2-100 and SL2-100
MACRO board	
ACC-5E3	For Power Series
Power supply	
ACC-E1	115/230 VAC input UMAC power supply
ACC-F1	24 VDC input UMAC power supply

OMRON AUTOMATION AMERICAS HEADQUARTERS • Chicago, IL USA • 847.843.7900 • 800.556.6766 • automation.omron.com

OMRON CANADA, INC. • HEAD OFFICE

Toronto, ON, Canada • 416.286.6465 • 866.986.6766 • automation.omron.com

OMRON ELECTRONICS DE MEXICO • HEAD OFFICE

Ciudad de México • 52.55.5901.4300 • 01.800.386.6766 • mela@omron.com

OMRON ELECTRONICS DE MEXICO • SALES OFFICE

San Pedro Garza García, N.L. • 81.12.53.7392 • 01.800.386.6766 • mela@omron.com

OMRON ELECTRONICS DE MEXICO • SALES OFFICE

Eugenio Garza Sada, León, Gto • 01.800.386.6766 • mela@omron.com

OMRON ELETRÔNICA DO BRASIL LTDA • HEAD OFFICE

São Paulo, SP, Brasil • 55 11 5171-8920 • automation.omron.com

OMRON ARGENTINA • SALES OFFICE

Buenos Aires, Argentina • +54.11.4521.8630 • +54.11.4523.8483
mela@omron.com

OTHER OMRON LATIN AMERICA SALES

+54.11.4521.8630 • +54.11.4523.8483 • mela@omron.com

Authorized Distributor:

Controllers & I/O

- Machine Automation Controllers (MAC) • Motion Controllers
- Programmable Logic Controllers (PLC) • Temperature Controllers • Remote I/O

Robotics

- Industrial Robots • Mobile Robots

Operator Interfaces

- Human Machine Interface (HMI)

Motion & Drives

- Machine Automation Controllers (MAC) • Motion Controllers • Servo Systems
- Frequency Inverters

Vision, Measurement & Identification

- Vision Sensors & Systems • Measurement Sensors • Auto Identification Systems

Sensing

- Photoelectric Sensors • Fiber-Optic Sensors • Proximity Sensors
- Rotary Encoders • Ultrasonic Sensors

Safety

- Safety Light Curtains • Safety Laser Scanners • Programmable Safety Systems
- Safety Mats and Edges • Safety Door Switches • Emergency Stop Devices
- Safety Switches & Operator Controls • Safety Monitoring/Force-guided Relays

Control Components

- Power Supplies • Timers • Counters • Programmable Relays
- Digital Panel Meters • Monitoring Products

Switches & Relays

- Limit Switches • Pushbutton Switches • Electromechanical Relays
- Solid State Relays

Software

- Programming & Configuration • Runtime