

< DIIPM >

# PSS15S92F6-AG PSS15S92E6-AG

TRANSFER MOLDING TYPE  
INSULATED TYPE

## OUTLINE

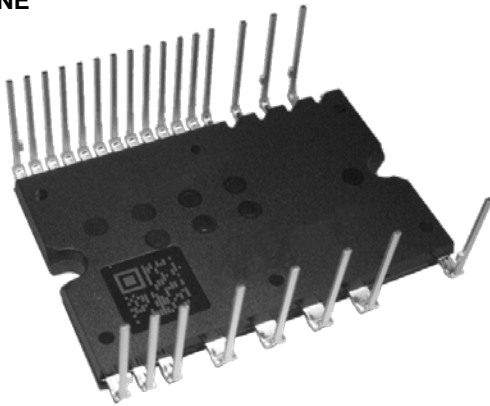

## MAIN FUNCTION AND RATINGS

- 3 phase DC/AC inverter
- 600V / 15A (CSTBT)
- N-side IGBT open emitter
- Built-in bootstrap diodes with current limiting resistor

## APPLICATION

- AC 100~240Vrms(DC voltage:400V or below) class low power motor control

## TYPE NAME

PSS15S92F6-AG	With temperature output function
PSS15S92E6-AG	With OT protection function

## INTEGRATED DRIVE, PROTECTION AND SYSTEM CONTROL FUNCTIONS

- For P-side : Drive circuit, High voltage high-speed level shifting, Control supply under-voltage (UV) protection
- For N-side : Drive circuit, Control supply under-voltage protection (UV), Short circuit protection (SC), Over temperature protection (OT, PSS15S92E6-AG only)
- Fault signaling : Corresponding to SC fault (N-side IGBT), UV fault (N-side supply) and OT fault
- Temperature output : Outputting LVIC temperature by analog signal (PSS15S92F6-AG only)
- Input interface : 3, 5V line, Schmitt trigger receiver circuit (High Active)
- UL Recognized : UL1557 File E323585

## INTERNAL CIRCUIT

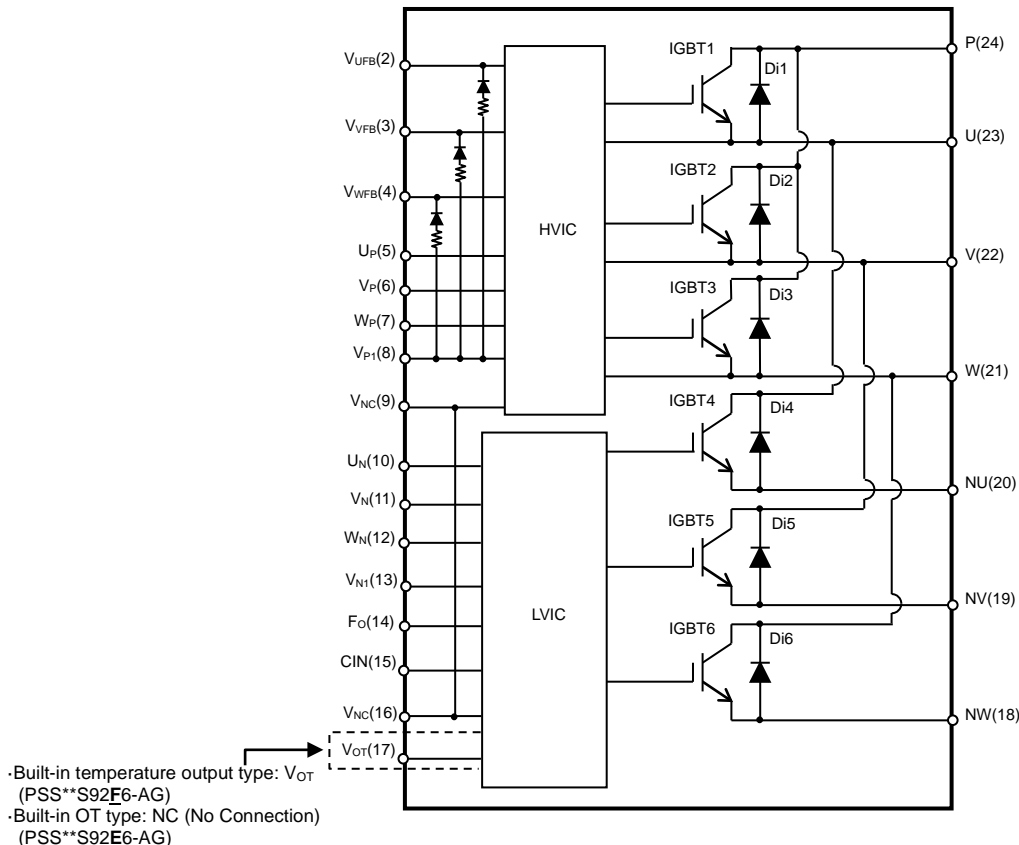

# PSS15S92F6-AG, PSS15S92E6-AG

TRANSFER MOLDING TYPE  
INSULATED TYPE

## MAXIMUM RATINGS (T<sub>j</sub> = 25°C, unless otherwise noted)

### INVERTER PART

Symbol	Parameter	Condition	Ratings	Unit
V <sub>CC</sub>	Supply voltage	Applied between P-NU,NV,NW	450	V
V <sub>CC(surge)</sub>	Supply voltage (surge)	Applied between P-NU,NV,NW	500	V
V <sub>CES</sub>	Collector-emitter voltage		600	V
±I <sub>C</sub>	Each IGBT collector current	T <sub>C</sub> = 25°C (Note 1)	15	A
±I <sub>CP</sub>	Each IGBT collector current (peak)	T <sub>C</sub> = 25°C, less than 1ms	30	A
P <sub>C</sub>	Collector dissipation	T <sub>C</sub> = 25°C, per 1 chip	27.0	W
T <sub>j</sub>	Junction temperature	(Note 2)	-30~+150	°C

Note1: Pulse width and period are limited due to junction temperature.

Note2: The maximum junction temperature rating of built-in power chips is 150°C (@T<sub>C</sub>≤100°C). However, to ensure safe operation of DIIPM, the average junction temperature should be limited to T<sub>j(Ave)</sub>≤125°C (@T<sub>C</sub>≤100°C).

### CONTROL (PROTECTION) PART

Symbol	Parameter	Condition	Ratings	Unit
V <sub>D</sub>	Control supply voltage	Applied between V <sub>P1</sub> -V <sub>NC</sub> , V <sub>N1</sub> -V <sub>NC</sub>	20	V
V <sub>DB</sub>	Control supply voltage	Applied between V <sub>UFB-U</sub> , V <sub>VFB-V</sub> , V <sub>WFB-W</sub>	20	V
V <sub>IN</sub>	Input voltage	Applied between U <sub>P</sub> , V <sub>P</sub> , W <sub>P</sub> -V <sub>PC</sub> , U <sub>N</sub> , V <sub>N</sub> , W <sub>N</sub> -V <sub>NC</sub>	-0.5~V <sub>D</sub> +0.5	V
V <sub>FO</sub>	Fault output supply voltage	Applied between F <sub>O</sub> -V <sub>NC</sub>	-0.5~V <sub>D</sub> +0.5	V
I <sub>FO</sub>	Fault output current	Sink current at F <sub>O</sub> terminal	1	mA
V <sub>SC</sub>	Current sensing input voltage	Applied between CIN-V <sub>NC</sub>	-0.5~V <sub>D</sub> +0.5	V

### TOTAL SYSTEM

Symbol	Parameter	Condition	Ratings	Unit
V <sub>CC(PROT)</sub>	Self protection supply voltage limit (Short circuit protection capability)	V <sub>D</sub> = 13.5~16.5V, Inverter Part T <sub>j</sub> = 125°C, non-repetitive, less than 2μs	400	V
T <sub>C</sub>	Module case operation temperature	Measurement point of T <sub>C</sub> is provided in Fig.1	-30~+100	°C
T <sub>stg</sub>	Storage temperature		-40~+125	°C
V <sub>iso</sub>	Isolation voltage	60Hz, Sinusoidal, AC 1min, between connected all pins and heat sink plate	1500	V <sub>rms</sub>

Fig. 1: T<sub>C</sub> MEASUREMENT POINT

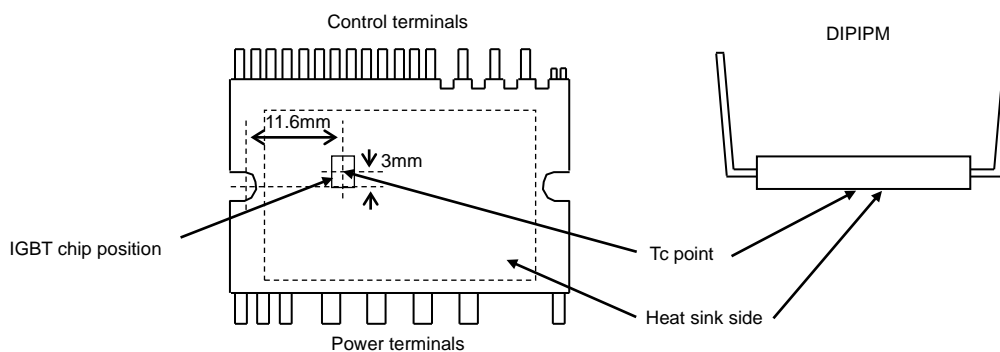

### THERMAL RESISTANCE

Symbol	Parameter	Condition	Limits			Unit
			Min.	Typ.	Max.	
R <sub>th(j-c)Q</sub>	Junction to case thermal resistance (Note 3)	Inverter IGBT part (per 1/6 module)	-	-	3.7	K/W
R <sub>th(j-c)F</sub>		Inverter FWDi part (per 1/6 module)	-	-	4.5	K/W

Note 3: Grease with good thermal conductivity and long-term endurance should be applied evenly with about +100μm~+200μm on the contacting surface of DIIPM and heat sink. The contacting thermal resistance between DIIPM case and heat sink R<sub>th(c-f)</sub> is determined by the thickness and the thermal conductivity of the applied grease. For reference, R<sub>th(c-f)</sub> is about 0.3K/W (per 1/6 module, grease thickness: 20μm, thermal conductivity: 1.0W/m·k).

# PSS15S92F6-AG, PSS15S92E6-AG

TRANSFER MOLDING TYPE  
INSULATED TYPE

## ELECTRICAL CHARACTERISTICS (T<sub>j</sub> = 25°C, unless otherwise noted)

### INVERTER PART

Symbol	Parameter	Condition	Limits			Unit	
			Min.	Typ.	Max.		
V <sub>CE(sat)</sub>	Collector-emitter saturation voltage	V <sub>D</sub> =V <sub>DB</sub> = 15V, V <sub>IN</sub> = 5V	I <sub>C</sub> = 15A, T <sub>j</sub> = 25°C	-	1.70	2.05	V
			I <sub>C</sub> = 15A, T <sub>j</sub> = 125°C	-	1.90	2.25	
			I <sub>C</sub> =1.5A, T <sub>j</sub> = 25°C	-	0.90	1.10	
V <sub>EC</sub>	FWDi forward voltage	V <sub>IN</sub> = 0V, -I <sub>C</sub> = 15A	-	2.50	3.00	V	
t <sub>on</sub>	Switching times	V <sub>CC</sub> = 300V, V <sub>D</sub> = V <sub>DB</sub> = 15V I <sub>C</sub> = 15A, T <sub>j</sub> = 125°C, V <sub>IN</sub> = 0→5V Inductive Load (upper-lower arm)		0.65	1.05	1.45	μs
t <sub>C(on)</sub>				-	0.40	0.65	μs
t <sub>off</sub>				-	1.15	1.60	μs
t <sub>C(off)</sub>				-	0.15	0.30	μs
t <sub>rr</sub>				-	0.30	-	μs
I <sub>CES</sub>	Collector-emitter cut-off current	V <sub>CE</sub> =V <sub>CES</sub>	T <sub>j</sub> = 25°C	-	-	1	mA
			T <sub>j</sub> = 125°C	-	-	10	

### CONTROL (PROTECTION) PART

Symbol	Parameter	Condition	Limits			Unit	
			Min.	Typ.	Max.		
I <sub>D</sub>	Circuit current	Total of V <sub>P1</sub> -V <sub>NC</sub> , V <sub>N1</sub> -V <sub>NC</sub>	V <sub>D</sub> =15V, V <sub>IN</sub> =0V	-	-	2.80	mA
			V <sub>D</sub> =15V, V <sub>IN</sub> =5V	-	-	2.80	
I <sub>DB</sub>		Each part of V <sub>UFB</sub> -U, V <sub>VFB</sub> -V, V <sub>WFB</sub> -W	V <sub>D</sub> =V <sub>DB</sub> =15V, V <sub>IN</sub> =0V	-	-	0.10	mA
			V <sub>D</sub> =V <sub>DB</sub> =15V, V <sub>IN</sub> =5V	-	-	0.10	
V <sub>SC(ref)</sub>	Short circuit trip level	V <sub>D</sub> = 15V (Note 4)	0.455	0.480	0.505	V	
UV <sub>DBt</sub>	P-side Control supply under-voltage protection(UV)	T <sub>j</sub> ≤125°C	Trip level	7.0	10.0	12.0	V
UV <sub>DBr</sub>			Reset level	7.0	10.0	12.0	V
UV <sub>Dt</sub>	N-side Control supply under-voltage protection(UV)	T <sub>j</sub> ≤125°C	Trip level	10.3	-	12.5	V
UV <sub>Dr</sub>			Reset level	10.8	-	13.0	V
V <sub>OT</sub>	Temperature Output (PSS**S92E6-AG)	Pull down R=5kΩ (Note 5)	LVIC Temperature=90°C	2.63	2.77	2.91	V
			LVIC Temperature=25°C	0.88	1.13	1.39	V
OT <sub>t</sub>	Over temperature protection	V <sub>D</sub> = 15V	Trip level	100	120	140	°C
OT <sub>th</sub>	(OT, PSS**S92E6-AG) (Note6)	Detect LVIC temperature	Hysteresis of trip-reset	-	10	-	°C
V <sub>FOH</sub>	Fault output voltage	V <sub>SC</sub> = 0V, F <sub>O</sub> terminal pulled up to 5V by 10kΩ		4.9	-	-	V
V <sub>FOL</sub>		V <sub>SC</sub> = 1V, I <sub>FO</sub> = 1mA		-	-	0.95	V
t <sub>FO</sub>	Fault output pulse width	(Note 7)		20	-	-	μs
I <sub>IN</sub>	Input current	V <sub>IN</sub> = 5V		0.70	1.00	1.50	mA
V <sub>th(on)</sub>	ON threshold voltage	Applied between U <sub>P</sub> , V <sub>P</sub> , W <sub>P</sub> , U <sub>N</sub> , V <sub>N</sub> , W <sub>N</sub> -V <sub>NC</sub>		-	2.10	2.60	V
V <sub>th(off)</sub>	OFF threshold voltage			0.80	1.30	-	
V <sub>th(hys)</sub>	ON/OFF threshold hysteresis voltage			0.35	0.65	-	
V <sub>F</sub>	Bootstrap Di forward voltage	I <sub>F</sub> =10mA including voltage drop by limiting resistor (Note 8)		1.1	1.7	2.3	V
R	Built-in limiting resistance	Included in bootstrap Di		80	100	120	Ω

- Note 4 : SC protection works only for N-side IGBT. Please select the external shunt resistance such that the SC trip-level is less than 1.7 times of the current rating.  
 5 : DIIPM don't shutdown IGBTs and output fault signal automatically when temperature rises excessively. When temperature exceeds the protective level that user defined, controller (MCU) should stop the DIIPM. Temperature of LVIC vs. VOT output characteristics is described in Fig. 3.  
 6 : When the LVIC temperature exceeds OT trip temperature level(OT<sub>t</sub>), OT protection works and Fo outputs. In that case if the heat sink dropped off or fixed loosely, don't reuse that DIIPM. (There is a possibility that junction temperature of power chips exceeded maximum T<sub>j</sub>(150°C).  
 7 : Fault signal Fo outputs when SC, UV or OT protection works. Fo pulse width is different for each protection modes. At SC failure, Fo pulse width is a fixed width (=minimum 20μs), but at UV or OT failure, Fo outputs continuously until recovering from UV or OT state. (But minimum Fo pulse width is 20μs.)  
 8 : The characteristics of bootstrap Di is described in Fig.2.

Fig. 2 Characteristics of bootstrap Di V<sub>F</sub>-I<sub>F</sub> curve (@Ta=25°C) including voltage drop by limiting resistor (Right chart is enlarged chart.)

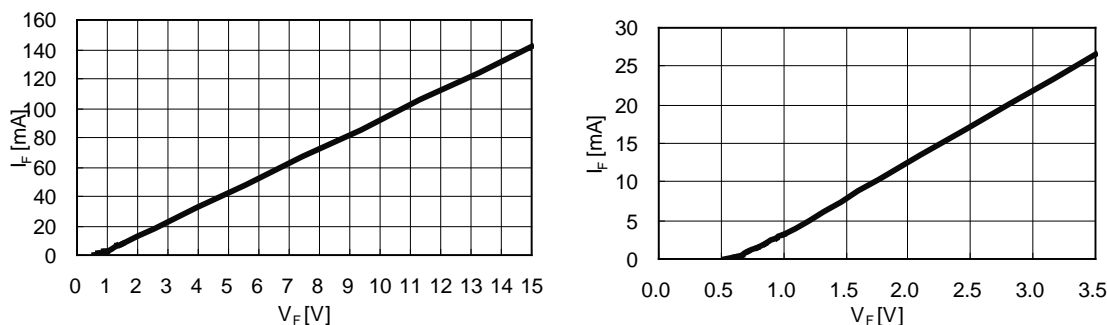

Fig. 3 Temperature of LVIC vs.  $V_{OT}$  output characteristics

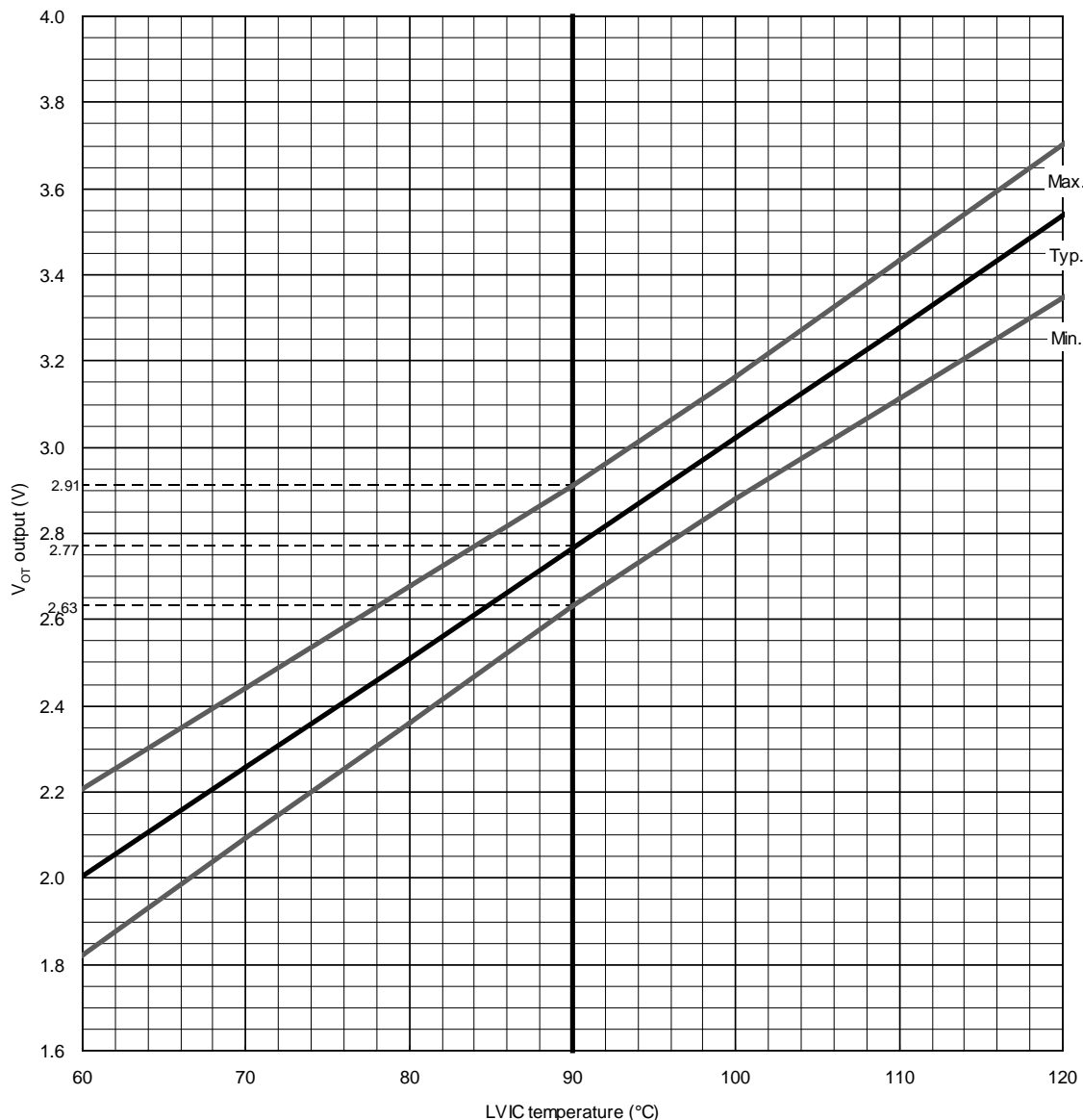
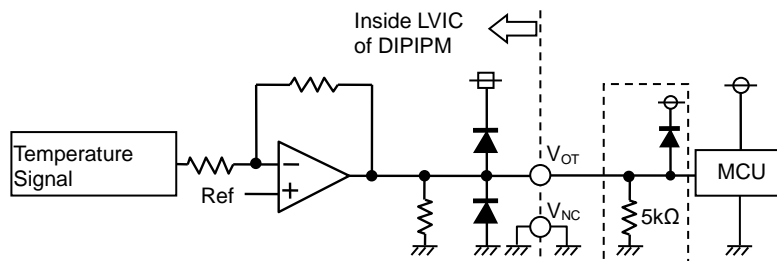

Fig. 4  $V_{OT}$  output circuit



- (1) It is recommended to insert 5kΩ (5.1kΩ is recommended) pull down resistor for getting linear output characteristics at low temperature below room temperature. When the pull down resistor is inserted between  $V_{OT}$  and  $V_{NC}$ (control GND), the extra circuit current, which is calculated approximately by  $V_{OT}$  output voltage divided by pull down resistance, flows as LVIC circuit current continuously. In the case of using  $V_{OT}$  for detecting high temperature over room temperature only, it is unnecessary to insert the pull down resistor.
- (2) In the case of using  $V_{OT}$  with low voltage controller like 3.3V MCU,  $V_{OT}$  output might exceed control supply voltage 3.3V when temperature rises excessively. If system uses low voltage controller, it is recommended to insert a clamp Di between control supply of the controller and  $V_{OT}$  output for preventing over voltage destruction.
- (3) In the case of not using  $V_{OT}$ , leave  $V_{OT}$  output NC (No Connection).

Refer the application note for Super Mini DIIPM Ver.5 series about the usage of  $V_{OT}$ .

# PSS15S92F6-AG, PSS15S92E6-AG

TRANSFER MOLDING TYPE  
INSULATED TYPE

## MECHANICAL CHARACTERISTICS AND RATINGS

Parameter	Condition		Limits			Unit
			Min.	Typ.	Max.	
Mounting torque	Mounting screw : M3 (Note 9)	Recommended 0.69N·m	0.59	0.69	0.78	N·m
Terminal pulling strength	Control terminal: Load 4.9N Power terminal: Load 9.8N	JEITA-ED-4701	10	-	-	s
Terminal bending strength	Control terminal: Load 2.45N Power terminal: Load 4.9N 90deg. bend	JEITA-ED-4701	2	-	-	times
Weight			-	8.5	-	g
Heat-sink flatness	(Note 10)		-50	-	100	μm

Note 9: Plain washers (ISO 7089-7094) are recommended.

Note 10: Measurement point of heat sink flatness

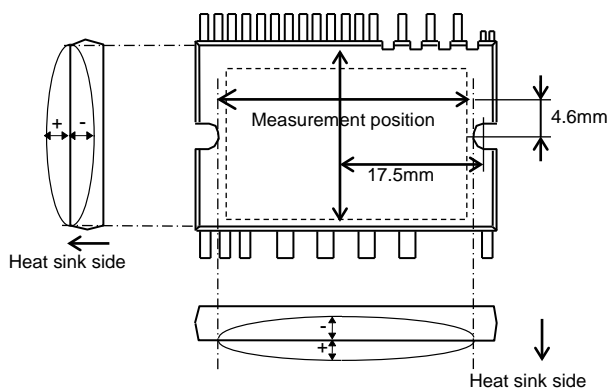

## RECOMMENDED OPERATION CONDITIONS

Symbol	Parameter	Condition	Limits			Unit	
			Min.	Typ.	Max.		
$V_{CC}$	Supply voltage	Applied between P-NU, NV, NW	0	300	400	V	
$V_D$	Control supply voltage	Applied between $V_{P1}-V_{NC}$ , $V_{N1}-V_{NC}$	13.5	15.0	16.5	V	
$V_{DB}$	Control supply voltage	Applied between $V_{UFB}-U$ , $V_{VFB}-V$ , $V_{WFB}-W$	13.0	15.0	18.5	V	
$\Delta V_D, \Delta V_{DB}$	Control supply variation		-1	-	+1	V/μs	
$t_{dead}$	Arm shoot-through blocking time	For each input signal	1.0	-	-	μs	
$f_{PWM}$	PWM input frequency	$T_C \leq 100^\circ C, T_j \leq 125^\circ C$	-	-	20	kHz	
$I_o$	Allowable r.m.s. current	$V_{CC} = 300V, V_D = 15V, P.F = 0.8,$ Sinusoidal PWM $T_C \leq 100^\circ C, T_j \leq 125^\circ C$ (Note11)	$f_{PWM} = 5kHz$	-	-	7.5	Arms
			$f_{PWM} = 15kHz$	-	-	4.5	
$P_{WIN(on)}$	Minimum input pulse width	(Note 12)	0.7	-	-	μs	
$P_{WIN(off)}$			0.7	-	-		
$V_{NC}$	$V_{NC}$ variation	Between $V_{NC}-NU, NV, NW$ (including surge)	-5.0	-	+5.0	V	
$T_j$	Junction temperature		-20	-	+125	°C	

Note 11: Allowable r.m.s. current depends on the actual application conditions.

12: DIIPM might not make response if the input signal pulse width is less than  $P_{WIN(on)}$ ,  $P_{WIN(off)}$ .

# PSS15S92F6-AG, PSS15S92E6-AG

TRANSFER MOLDING TYPE  
INSULATED TYPE

Fig. 5 Timing Charts of The DIIPM Protective Functions

[A] Short-Circuit Protection (N-side only with the external shunt resistor and RC filter)

- a1. Normal operation: IGBT ON and outputs current.
- a2. Short circuit current detection (SC trigger)  
(It is recommended to set RC time constant 1.5~2.0μs so that IGBT shut down within 2.0μs when SC.)
- a3. All N-side IGBT's gates are hard interrupted.
- a4. All N-side IGBTs turn OFF.
- a5. F<sub>O</sub> outputs for t<sub>Fo</sub>=minimum 20μs.
- a6. Input = "L": IGBT OFF
- a7. F<sub>o</sub> finishes output, but IGBTs don't turn on until inputting next ON signal (L→H).
- (IGBT of each phase can return to normal state by inputting ON signal to each phase.)
- a8. Normal operation: IGBT ON and outputs current.

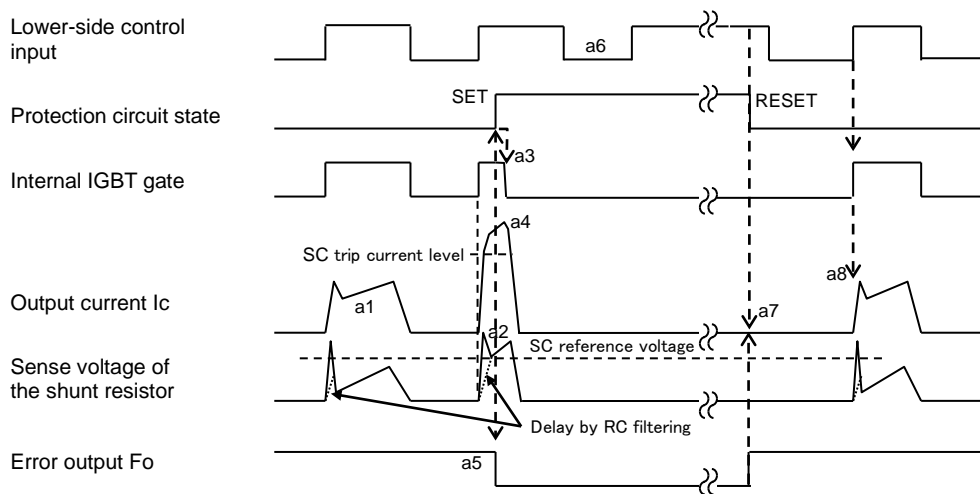

[B] Under-Voltage Protection (N-side, UV<sub>D</sub>)

- b1. Control supply voltage V<sub>D</sub> exceeds under voltage reset level (UV<sub>Dr</sub>), but IGBT turns ON by next ON signal (L→H).  
(IGBT of each phase can return to normal state by inputting ON signal to each phase.)
- b2. Normal operation: IGBT ON and outputs current.
- b3. V<sub>D</sub> level drops to under voltage trip level. (UV<sub>Dt</sub>).
- b4. All N-side IGBTs turn OFF in spite of control input condition.
- b5. F<sub>o</sub> outputs for t<sub>Fo</sub>=minimum 20μs, but output is extended during V<sub>D</sub> keeps below UV<sub>Dr</sub>.
- b6. V<sub>D</sub> level reaches UV<sub>Dr</sub>.
- b7. Normal operation: IGBT ON and outputs current.

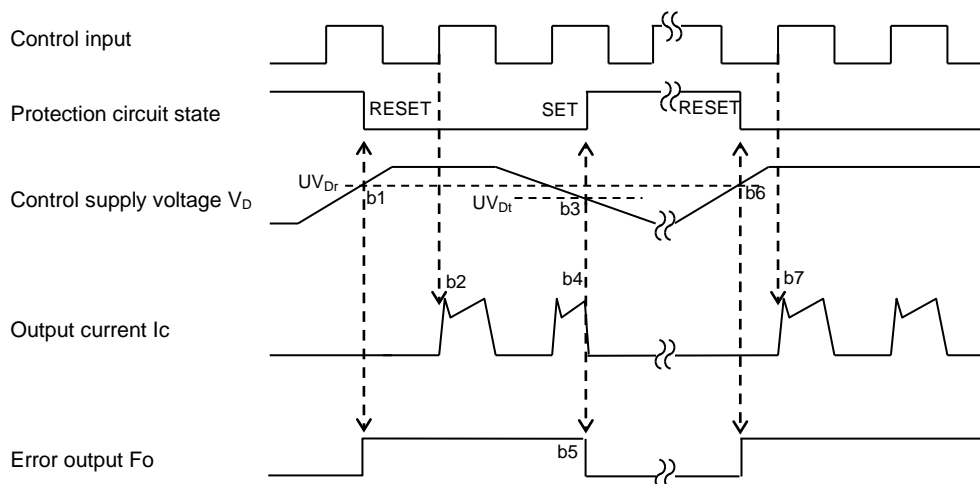

# PSS15S92F6-AG, PSS15S92E6-AG

TRANSFER MOLDING TYPE  
INSULATED TYPE

### [C] Under-Voltage Protection (P-side, $UV_{DB}$ )

- c1. Control supply voltage  $V_{DB}$  rises. After the voltage reaches under voltage reset level  $UV_{DBr}$ , IGBT turns on by next ON signal (L→H).
- c2. Normal operation: IGBT ON and outputs current.
- c3.  $V_{DB}$  level drops to under voltage trip level ( $UV_{DBt}$ ).
- c4. IGBT of the correspond phase only turns OFF in spite of control input signal level, but there is no  $F_o$  signal output.
- c5.  $V_{DB}$  level reaches  $UV_{DBr}$ .
- c6. Normal operation: IGBT ON and outputs current.

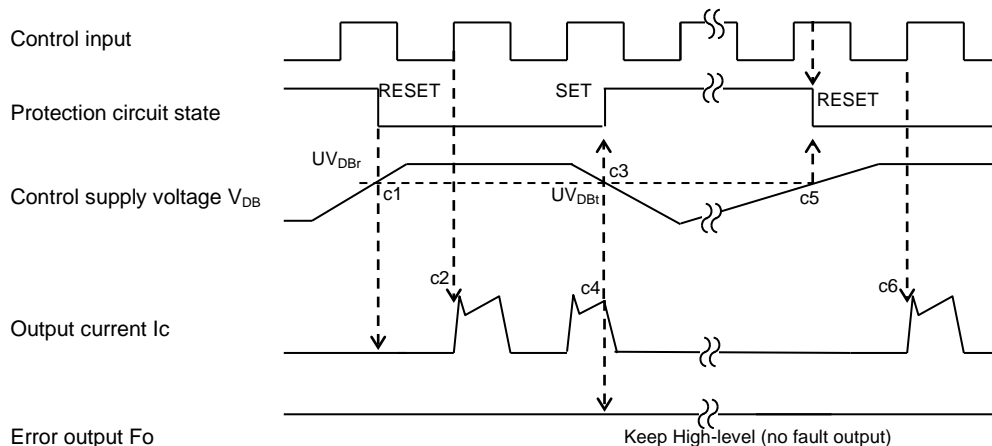

### [D] Over Temperature Protection (N-side, Detecting LVIC temperature)

- d1. Normal operation: IGBT ON and outputs current.
  - d2. LVIC temperature exceeds over temperature trip level ( $OT_t$ ).
  - d3. All N-side IGBTs turn OFF in spite of control input condition.
  - d4.  $F_o$  outputs for  $t_{Fo}$ =minimum 20 $\mu$ s, but output is extended during LVIC temperature keeps over  $OT_t$ .
  - d5. LVIC temperature drops to over temperature reset level.
  - d6. Normal operation: IGBT turns on by next ON signal (L→H).
- (IGBT of each phase can return to normal state by inputting ON signal to each phase.)

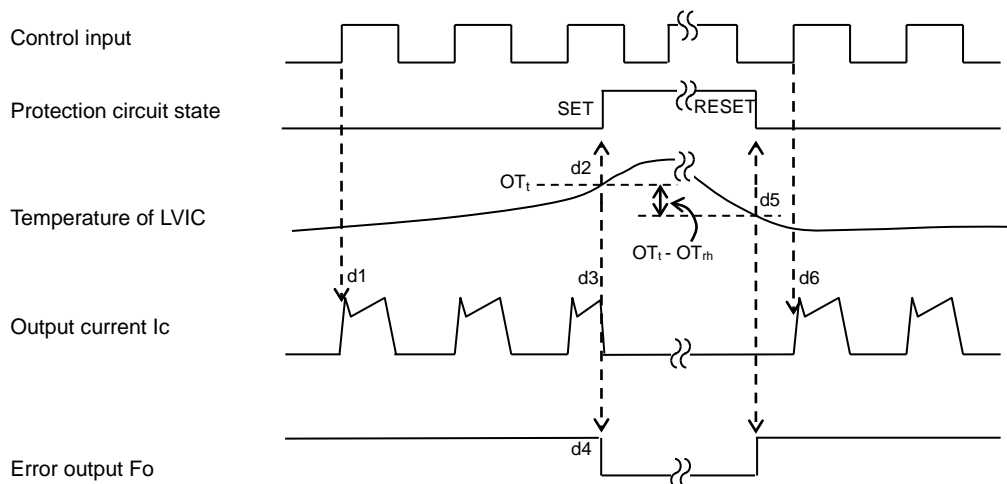

# PSS15S92F6-AG, PSS15S92E6-AG

TRANSFER MOLDING TYPE  
INSULATED TYPE

Fig. 6 Example of Application Circuit

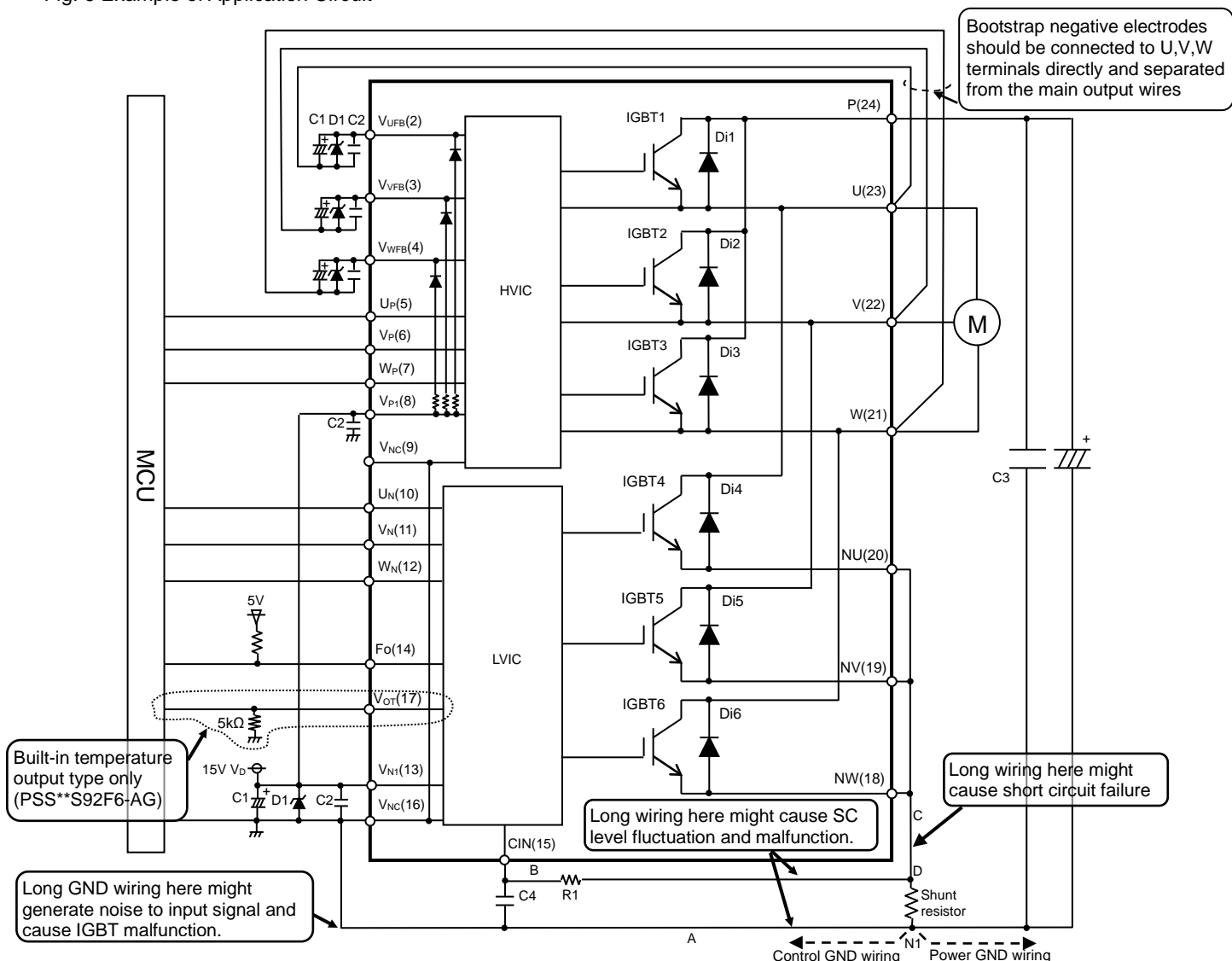

- (1) If control GND is connected with power GND by common broad pattern, it may cause malfunction by power GND fluctuation. It is recommended to connect control GND and power GND at only a point N1 (near the terminal of shunt resistor).
- (2) It is recommended to insert a Zener diode D1(24V/1W) between each pair of control supply terminals to prevent surge destruction.
- (3) To prevent surge destruction, the wiring between the smoothing capacitor and the P, N1 terminals should be as short as possible. Generally a 0.1-0.22μF snubber capacitor C3 between the P-N1 terminals is recommended.
- (4) R1, C4 of RC filter for preventing protection circuit malfunction is recommended to select tight tolerance, temp-compensated type. The time constant R1C4 should be set so that SC current is shut down within 2μs. (1.5μs~2μs is general value.) SC interrupting time might vary with the wiring pattern, so the enough evaluation on the real system is necessary.
- (5) To prevent malfunction, the wiring of A, B, C should be as short as possible.
- (6) The point D at which the wiring to CIN filter is divided should be near the terminal of shunt resistor. NU, NV, NW terminals should be connected at near NU, NV, NW terminals.
- (7) All capacitors should be mounted as close to the terminals as possible. (C1: good temperature, frequency characteristic electrolytic type and C2:0.22μ-2μF, good temperature, frequency and DC bias characteristic ceramic type are recommended.)
- (8) Input drive is High-active type. There is a minimum 3.3kΩ pull-down resistor in the input circuit of IC. To prevent malfunction, the wiring of each input should be as short as possible. When using RC coupling circuit, make sure the input signal level meet the turn-on and turn-off threshold voltage.
- (9) Fo output is open drain type. It should be pulled up to MCU or control power supply (e.g. 5V,15V) by a resistor that makes I<sub>FO</sub> up to 1mA. (I<sub>FO</sub> is estimated roughly by the formula of control power supply voltage divided by pull-up resistance. In the case of pulled up to 5V, 10kΩ (5kΩ or more) is recommended.)
- (10) Thanks to built-in HVIC, direct coupling to MCU without any opto-coupler or transformer isolation is possible.
- (11) Two V<sub>NC</sub> terminals (9 & 16 pin) are connected inside DIIPM, please connect either one to the 15V power supply GND outside and leave another one open.
- (12) If high frequency noise superimposed to the control supply line, IC malfunction might happen and cause DIIPM erroneous operation. To avoid such problem, line ripple voltage should meet dV/dt ≤ +/ -1V/μs, V<sub>ripple</sub> ≤ 2Vp-p.
- (13) For DIIPM, it isn't recommended to drive same load by parallel connection with other phase IGBT or other DIIPM.



< DIPIPM >  
**PSS15S92F6-AG, PSS15S92E6-AG**  
 TRANSFER MOLDING TYPE  
 INSULATED TYPE

Fig. 7 MCU I/O Interface Circuit

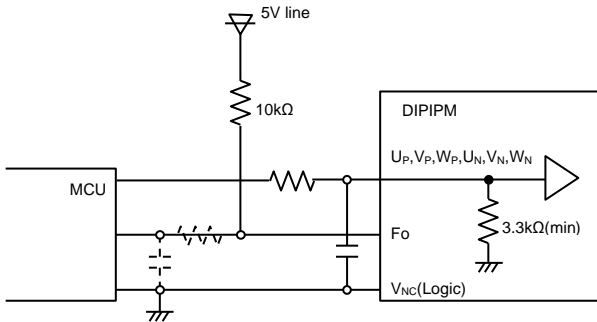

Note)

Design for input RC filter depends on PWM control scheme used in the application and wiring impedance of the printed circuit board. DIPIPM input signal interface integrates a minimum 3.3kΩ pull-down resistor. Therefore, when inserting RC filter, it is necessary to satisfy turn-on threshold voltage requirement. F<sub>o</sub> output is open drain type. It should be pulled up to control power supply (e.g. 5V, 15V) with a resistor that makes F<sub>o</sub> sink current I<sub>Fo</sub> 1mA or less. In the case of pulled up to 5V supply, 10kΩ (5kΩ or more) is recommended.

Fig. 8 Pattern Wiring Around the Shunt Resistor

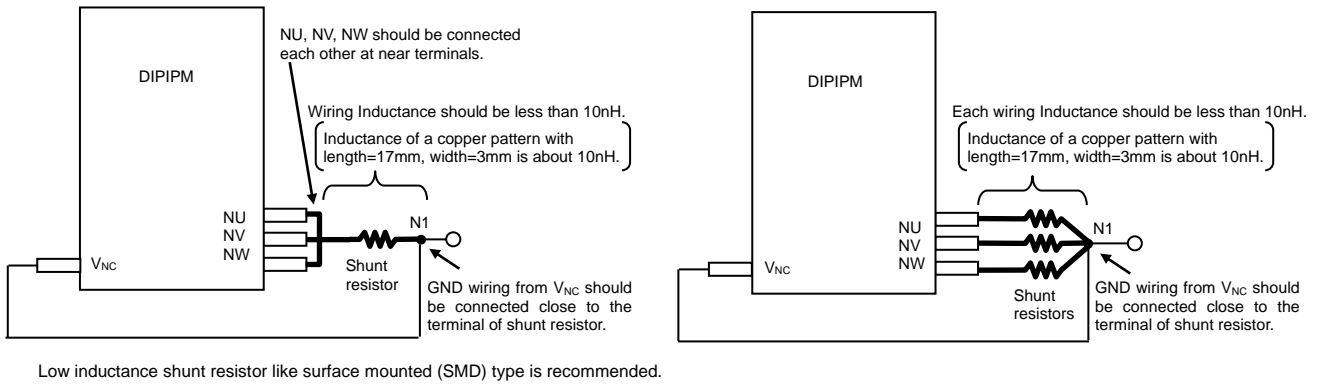
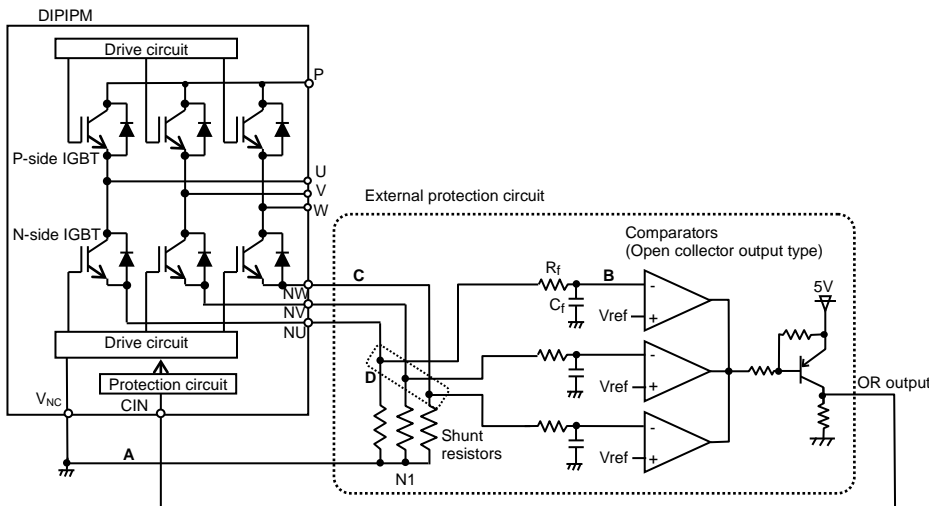

Fig. 9 Pattern Wiring Around the Shunt Resistor (for the case of open emitter)

When DIPIPM is operated with three shunt resistors, voltage of each shunt resistor cannot be input to CIN terminal directly. In that case, it is necessary to use the external protection circuit as below.



- (1) It is necessary to set the time constant  $R_f C_f$  of external comparator input so that IGBT stops within  $2\mu s$  when short circuit occurs. SC interrupting time might vary with the wiring pattern, comparator speed and so on.
- (2) It is recommended for the threshold voltage  $V_{ref}$  to set to the same rating of short circuit trip level ( $V_{sc(ref)}$ : typ. 0.48V).
- (3) Select the external shunt resistance so that SC trip-level is less than specified value (=1.7 times of rating current).
- (4) To avoid malfunction, the wiring A, B, C should be as short as possible.
- (5) The point D at which the wiring to comparator is divided should be close to the terminal of shunt resistor.
- (6) OR output high level when protection works should be over 0.505V (=maximum  $V_{sc(ref)}$  rating).

< DIIPM >  
**PSS15S92F6-AG, PSS15S92E6-AG**  
 TRANSFER MOLDING TYPE  
 INSULATED TYPE

Fig. 10 Package Outlines

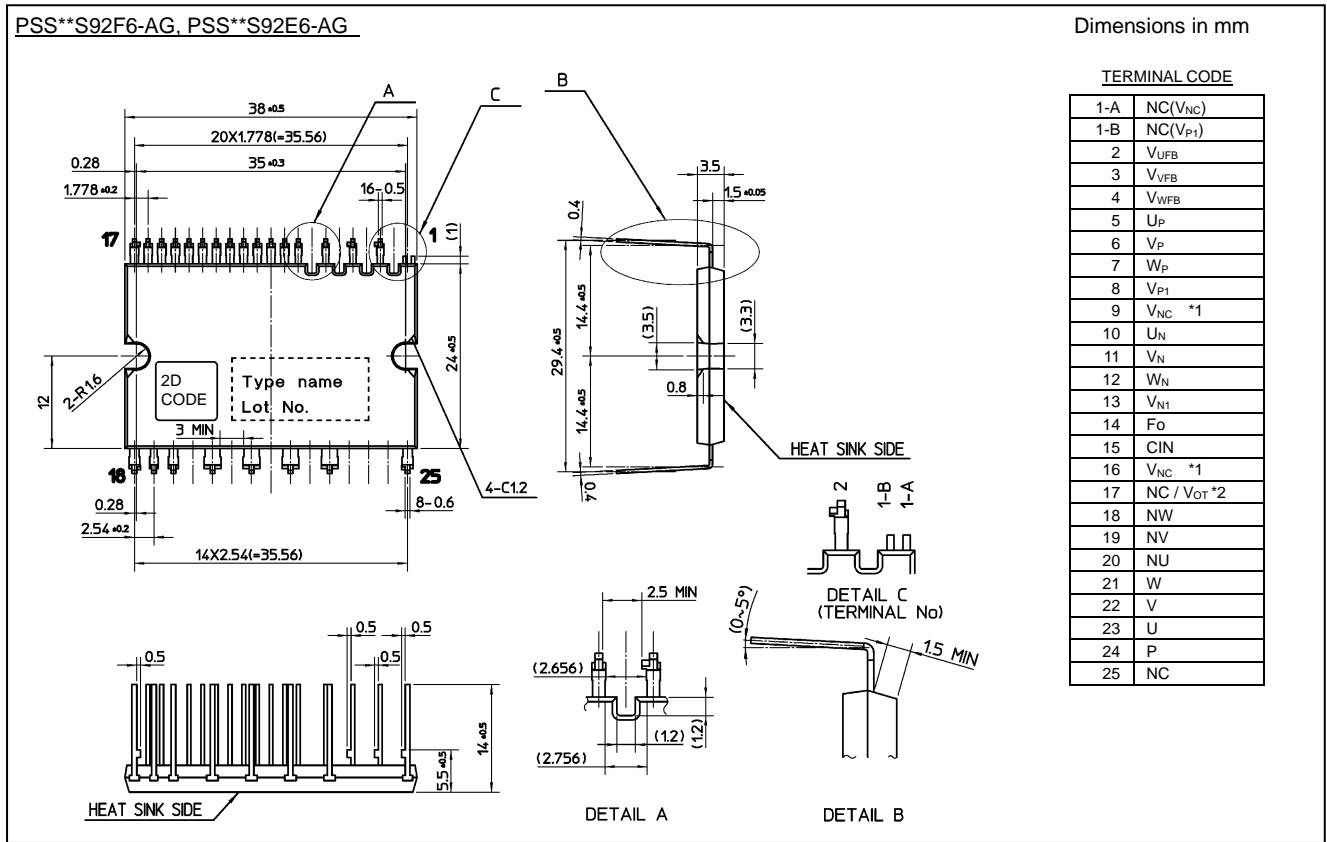

- 1) 9 & 16 pins (V<sub>NC</sub>) are connected inside DIIPM, please connect either one to the control power supply GND outside and leave another one open.
- 2) No.17 is V<sub>OT</sub> for built-in temperature output function type (PSS\*\*S92F6-AG) and NC (No Connection) for built-in OT protection function type (PSS\*\*S92E6-AG).

### **Important Notice**

The information contained in this datasheet shall in no event be regarded as a guarantee of conditions or characteristics. This product has to be used within its specified maximum ratings, and is subject to customer's compliance with any applicable legal requirement, norms and standards.

Except as otherwise explicitly approved by Mitsubishi Electric Corporation in a written document signed by authorized representatives of Mitsubishi Electric Corporation, our products may not be used in any applications where a failure of the product or any consequences of the use thereof can reasonably be expected to result in personal injury.

In usage of power semiconductor, there is always the possibility that trouble may occur with them by the reliability lifetime such as Power Cycle, Thermal Cycle or others, or when used under special circumstances (e.g. condensation, high humidity, dusty, salty, highlands, environment with lots of organic matter / corrosive gas / explosive gas, or situations which terminals of semiconductor products receive strong mechanical stress). Therefore, please pay sufficient attention to such circumstances. Further, depending on the technical requirements, our semiconductor products may contain environmental regulation substances, etc. If there is necessity of detailed confirmation, please contact our nearest sales branch or distributor.

The contents or data contained in this datasheet are exclusively intended for technically trained staff. Customer's technical departments should take responsibility to evaluate the suitability of Mitsubishi Electric Corporation product for the intended application and the completeness of the product data with respect to such application. In the customer's research and development, please evaluate it not only with a single semiconductor product but also in the entire system, and judge whether it's applicable. As required, pay close attention to the safety design by installing appropriate fuse or circuit breaker between a power supply and semiconductor products to prevent secondary damage. Please also pay attention to the application note and the related technical information.

**Keep safety first in your circuit designs!**

Mitsubishi Electric Corporation puts the maximum effort into making semiconductor products better and more reliable, but there is always the possibility that trouble may occur with them. Trouble with semiconductors may lead to personal injury, fire or property damage. Remember to give due consideration to safety when making your circuit designs, with appropriate measures such as (i) placement of substitutive, auxiliary circuits, (ii) use of non-flammable material or (iii) prevention against any malfunction or mishap.

**Notes regarding these materials**

- These materials are intended as a reference to assist our customers in the selection of the Mitsubishi Electric Semiconductor product best suited to the customer's application; they do not convey any license under any intellectual property rights, or any other rights, belonging to Mitsubishi Electric Corporation or a third party.
- Mitsubishi Electric Corporation assumes no responsibility for any damage, or infringement of any third-party's rights, originating in the use of any product data, diagrams, charts, programs, algorithms, or circuit application examples contained in these materials.
- All information contained in these materials, including product data, diagrams, charts, programs and algorithms represents information on products at the time of publication of these materials, and are subject to change by Mitsubishi Electric Corporation without notice due to product improvements or other reasons. It is therefore recommended that customers contact Mitsubishi Electric Corporation or an authorized Mitsubishi Electric Semiconductor product distributor for the latest product information before purchasing a product listed herein.  
The information described here may contain technical inaccuracies or typographical errors. Mitsubishi Electric Corporation assumes no responsibility for any damage, liability, or other loss rising from these inaccuracies or errors.  
Please also pay attention to information published by Mitsubishi Electric Corporation by various means, including the Mitsubishi Electric Semiconductor home page (<http://www.MitsubishiElectric.com/semiconductors/>).
- When using any or all of the information contained in these materials, including product data, diagrams, charts, programs, and algorithms, please be sure to evaluate all information as a total system before making a final decision on the applicability of the information and products. Mitsubishi Electric Corporation assumes no responsibility for any damage, liability or other loss resulting from the information contained herein.
- Mitsubishi Electric Corporation semiconductors are not designed or manufactured for use in a device or system that is used under circumstances in which human life is potentially at stake. Please contact Mitsubishi Electric Corporation or an authorized Mitsubishi Electric Semiconductor product distributor when considering the use of a product contained herein for any specific purposes, such as apparatus or systems for transportation, vehicular, medical, aerospace, nuclear, or undersea repeater use.
- The prior written approval of Mitsubishi Electric Corporation is necessary to reprint or reproduce in whole or in part these materials.
- If these products or technologies are subject to the Japanese export control restrictions, they must be exported under a license from the Japanese government and cannot be imported into a country other than the approved destination.  
Any diversion or re-export contrary to the export control laws and regulations of Japan and/or the country of destination is prohibited.
- Please contact Mitsubishi Electric Corporation or an authorized Mitsubishi Electric Semiconductor product distributor for further details on these materials or the products contained therein.