



Changes for the Better

Magnetic Contactors and Magnetic Starters
INSTRUCTION MANUAL

MS-T Series

Magnetic Starter

INSTRUCTION MANUAL

MS-T Series Magnetic Starter and Magnetic Contactor

This document introduces the types, characteristics and performances (Type test results) of the magnetic starter, for the purpose of being generally utilized as a basic document by all the users including the administrators, designers, and those responsible for construction.

- Note a) Note that the described contents are subject to change without notice.
- b) The described content is only for reference and it cannot be guaranteed.

The units are described in SI units.

Table of Contents

Standard Series Magnetic Starter and Magnetic Contactor

Type and Rating	2
Characteristics and Performance	5
1. Structure	5
2. Type Test	5
2.1 Type Tests and Test Sequences	5
2.2 Test Sequence I	6
2.2.1 Verification of Temperature Rise and Dielectric Properties	6
2.2.2 Verification of Operating Limits	7
(1) Operating Limits of the Magnetic Contactor	7
(2) Operating Limits of the Thermal Relay	8
2.3 Test Sequence II	9
2.3.1 Test of Closed-circuit and Breaking Capacities	9
(1) Test of Closed-circuit Capacity	9
(2) Test of Closed-circuit and Breaking Capacities	10
(3) Verification of the Switching Capacity and Reversibility	10
2.3.2 Verification of the Operating Performance	12
(1) Non-reversible	12
(2) Reversible	13
2.4 Test Sequence III	14
2.4.1 Performance under Short-circuit Conditions	14
2.5 Test Sequence IV	15
2.5.1 Verification of Ability of Contactors to Withstand Overload Currents	15
2.6 Test Sequence V	16
2.6.1 Verification of Mechanical Properties of Terminals	16
(1) Tests of Mechanical Strength of Terminals	16
(2) Flexion and Pull-out Tests	17

Special Magnetic Contactor

DC-operated Magnetic Contactor <SD-T Type>	20
1. Structure	20
2. Rating	20
3. Type Test	20
3.1 Type Tests and Test Sequences	20
3.2 Test Sequence I	21
3.2.1 Verification of Temperature Rise and Dielectric Properties	21
3.2.2 Verification of Operating Limits	22

3.3 Test Sequence II	23
3.3.1 Test of Closed-circuit and Breaking Capacities	23
(1) Test of Closed-circuit Capacity	23
(2) Test of Closed-circuit and Breaking Capacities	23
(3) Verification of the Switching Capacity and Reversibility	24
3.3.2 Verification of the Operating Performance	25
(1) Non-reversible	25
(2) Reversible	25
3.4 Test Sequence III	26
3.4.1 Performance under Short-circuit Conditions	26
3.5 Test Sequence IV	26
3.5.1 Verification of Ability of Contactors to Withstand Overload Currents	26
3.6 Test Sequence V	27
3.6.1 Verification of Mechanical Properties of Terminals	27
(1) Tests of Mechanical Strength of Terminals	27
(2) Flexion and Pull-out Tests	28
Mechanical Latch Type Magnetic Contactor <SL-T, SLD-T Type>	29
1. Usage	29
2. Rating	29
3. Type Test	29
3.1 Type Tests and Test Sequences	29
3.2 Test Sequence I	30
3.2.1 Verification of Temperature Rise and Dielectric Properties	30
3.2.2 Verification of Operating Limits	30
3.3 Test Sequence II	30
3.3.1 Test of Closed-circuit and Breaking Capacities	30
(1) Test of Closed-circuit Capacity	30
(2) Test of Closed-circuit and Breaking Capacities	31
(3) Verification of the Switching Capacity and Reversibility	31
3.3.2 Verification of the Operating Performance	32
(1) Non-reversible	32
(2) Reversible	32
3.4 Test Sequence III	32
3.4.1 Performance under Short-circuit Conditions	32
3.5 Test Sequence IV	33
3.5.1 Verification of Ability of Contactors to Withstand Overload Currents	33
3.6 Test Sequence V	33
3.6.1 Verification of Mechanical Properties of Terminals	33
(1) Tests of Mechanical Strength of Terminals	33
(2) Flexion and Pull-out Tests	33

Environmental Characteristics and Special Performance

1. Surrounding Environment of the Magnetic Starter	36
2. Application to the Special Environment	37
2.1 High Temperature	37
2.2 Low Temperature	38
3. Instantaneous Voltage Drop Tolerance	39
3.1 SEMI-F47 Standard	39
3.2 Instantaneous Power Failure Tolerance	39
4. Operating Characteristics of the Thermal Relay	40
4.1 Operations in a Balanced Circuit (Ambient Temperature: 20°C)	40
4.2 Operations in an Unbalanced Circuit (Ambient Temperature: 20°C)	40
5. Noise Characteristics	41
5.1 Noise during the ON State	41
5.2 Noise during Opening and Closing	42
6. Impact during Opening and Closing	42
7. Insulation Resistance and Withstand Voltage	43
8. Vibration	43
8.1 Contact Malfunction Vibration	43
8.2 Constant Vibration Endurance	43
9. Impact	44
10. Mechanical Endurance	44
11. Electrical Endurance	45
12. Short Time Current Overload Tolerance of the Magnetic Contactor	46

**Standard Series
Magnetic Starter and
Magnetic Contactor**

■ Type and Rating

The MS-T type magnetic starter is composed of S-T type magnetic contactor, TH-T type thermal relay and an outer box. On the other hand, there is a MSO-T type magnetic starter used as a switchboard, control panel unit.

Table 1 MS-T Type Magnetic Starter Components

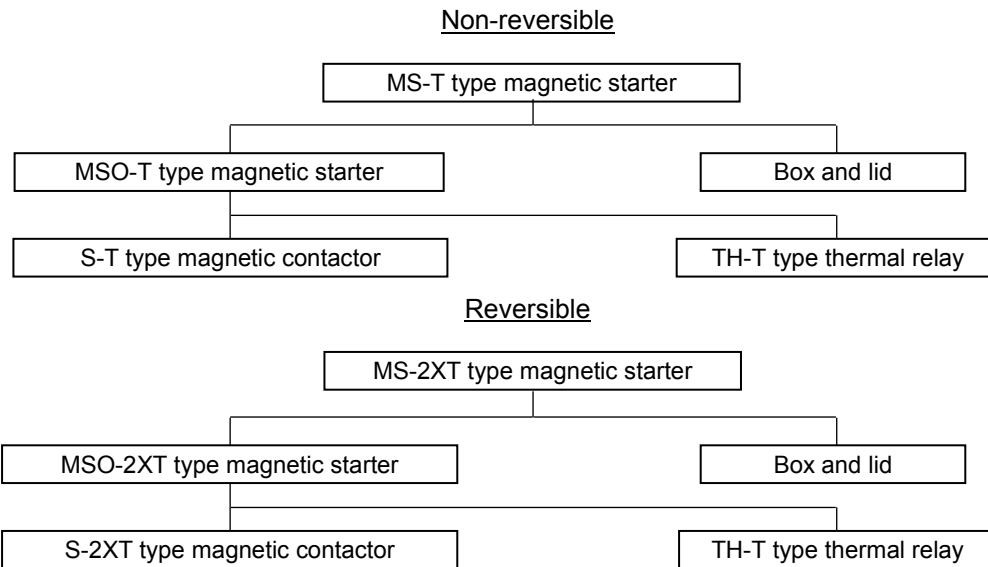

Table 2 Type and Composition

Frame	Type				Components		
	Magnetic starter in a box		Open-type magnetic starter		Magnetic contactor		Thermal relay
	Non-reversible	Reversible	Non-reversible	Reversible	Non-reversible	Reversible	
T10	MS-T10	-	MSO-T10	MSO-2xT10	S-T10	S-2xT10	TH-T18
T12	MS-T12	-	MSO-T12	MSO-2xT12	S-T12	S-2xT12	
T20	-	-	MSO-T20	MSO-2xT20	S-T20	S-2xT20	
T21	MS-T21	MS-2xT21	MSO-T21	MSO-2xT21	S-T21	S-2xT21	TH-T25
T25	-	-	MSO-T25	MSO-2xT25	S-T25	S-2xT25	
T32	-	-	-	-	S-T32	S-2xT32	
T35	Upcoming product		MSO-T35	MSO-2xT35	S-T35	S-2xT35	TH-T25 (Nominal current of the heater: 22 A or less) TH-T50 (Nominal current of the heater: 29 A)
T50			MSO-T50	MSO-2xT50	S-T50	S-2xT50	TH-T25 (Nominal current of the heater: 22 A or less) TH-T50 (Nominal current of the heater: 29 A or higher)
T65			MSO-T65	MSO-2xT65	S-T65	S-2xT65	TH-T65
T80			MSO-T80	MSO-2xT80	S-T80	S-2xT80	TH-T65 (Nominal current of the heater: 54 A or less) TH-T100 (Nominal current of the heater: 67 A)
T100			MSO-T100	MSO-2xT100	S-T100	S-2xT100	TH-T65 (Nominal current of the heater: 54 A or less) TH-T100 (Nominal current of the heater: 67 A or higher)

Table 3 Rating Capacity

Application Frame	Motor load [kW]					Three-phase resistance load (AC-grade 1)	
	Standard operation			Inching operation			
	Three-phase squirrel cage type motor (AC-grade 3)			Three-phase squirrel cage type motor (AC-grade 4)			
	200 to 200V	380 to 440V	500 to 550V	200 to 200V	380 to 550V	200 to 200V	400 to 440V
T10	2.2	2.7	2.7	1.5	2.7(2.2)	6.5	8
T12	2.7	4	5.5	2.2	5.5(4)	6.5	10
T20	3.7	7.5	7.5	3.7	5.5	6.5	10
T21	4	7.5	7.5	3.7	5.5	11	22
T25	5.5	11	11	4.5	7.5	11	22
T32	7.5	15	11	5.5	7.5(11)	11	22
T35	7.5	15	15	5.5	11	20	40
T50	11	22	22	7.5	15	27	55
T65	15	30	30	11	22	34	68
T80	19	37	45	15	30	41	83
T100	22	45	45	19	37	50	100

Note a) Brackets () in the inching operation indicate the rating of 380V to 440V.

Table 4 Rated Operating Current

Application Frame	Motor load						Resistance load		Open thermoelectric current I _{th} [A]
	Rated operating current of AC-grade 3 [A]			Rated operating current of AC-grade 4 [A]			Rated operating current of AC-grade 1 [A]		
	200 to 200V	380 to 440V	500 to 550V	200 to 200V	380 to 440V	500 to 550V	200 to 200V	400 to 440V	
T10	11	7	6	8	6	6	20	11	20
T12	13	9	9	11	9	9	20	13	20
T20	18	18	17	18	13	10	20	13	20
T21	18(20)	18(20)	17	18	13	10	32	32	32
T25	26	25	20	20	17	12	32	32	32
T32	32	32	20	26	24	13	32	32	32
T35	34(35)	32	26	26	24	17	60	60	60
T50	50	48	38	35	32	24	80	80	80
T65	65	65	45	50	47	38	100	100	100
T80	80	80	75	65	62	45	120	120	120
T100	100	93	75	80	75	55	150	150	150

Note a) Rated operating current is the maximum applicable current that satisfies the closed-circuit capacity, breaking capacity, switching frequency, and life at the rated operating voltage.

Note b) Open thermoelectric current is a current that can conduct the electricity for 8 hours without raising the temperature above the stated level for all the parts, without switching the magnetic contactor.

Note c) The values of rated operating current in brackets () apply to the magnetic contactor (without thermal relay).

Table 5 DC Rated Operating Current

Frame	Rated voltage DC [V]	Rated operating current of DC-grade 2, grade 4 (DC motor load) [A]		Rated operating current of DC-grade 1 (Resistance load) [A]		Rated operating current of DC-grade 13 (DC electromagnet load) [A]		
		2-polar series	3-polar series	2-polar series	3-polar series	Single pole	2-polar series	3-polar series
T10	24	8	8	10	10	5	8	8
	48	4	6	10	10	3	4	6
	110	2.5	4	6	8	0.6	2	3
	220	0.8	2	3	8	0.2	0.3	0.8
T12	24	12	12	12	12	7	12	12
	48	6	10	12	12	5	6	10
	110	4	8	10	12	1.2	3	5
	220	1.2	4	7	12	0.2	0.5	2
T20	24	18	18	18	18	10	14	15
	48	15	18	18	18	5	7	12
	110	8	15	13	18	1.2	3	5
	220	2	8	8	18	0.2	0.5	2
T21	24	20	20	20	20	12	20	20
	48	15	20	20	20	8	12	15
	110	8	15	15	20	1.5	3	10
	220	2	8	10	20	0.25	1.2	4
T25, T32	24	25	25	25	25	15	25	25
	48	20	25	25	25	10	15	25
	110	10	20	25	25	1.5	4	12
	220	3	10	12	22	0.25	1.2	4
T35	24	35	35	35	35	15	35	35
	48	20	30	35	35	10	15	25
	110	10	20	25	35	1.5	4	12
	220	3	10	12	30	0.25	1.2	4
T50	24	45	50	50	50	-	-	-
	48	25	35	40	50	-	-	-
	110	15	30	35	50	-	-	-
	220	3.5	12	15	40	-	-	-
T65	24	45	50	50	65	-	-	-
	48	25	35	40	65	-	-	-
	110	15	30	35	65	-	-	-
	220	3.5	12	15	50	-	-	-
T80	24	65	80	80	80	-	-	-
	48	40	60	65	80	-	-	-
	110	20	50	50	80	-	-	-
	220	5	20	20	60	-	-	-
T100	24	93	93	93	93	-	-	-
	48	60	90	93	93	-	-	-
	110	40	80	80	93	-	-	-
	220	30	50	50	70	-	-	-

Note a) DC-grade 2, DC-grade 4, and DC-grade 1 are the gradings of JEM1038 that are to be applied for starting and stopping the DC shunt-wound motor, starting and stopping the DC series motor, and resistance load respectively.

Note b) DC-grade 13 is the grading of JISC8201-5-1 which is to be applied to the induction (coil) load (time constant L/R = 100ms).

Note c) The opening and closing of the electrical switch can be done up to 500,000 times.

Note d) The closed current capacity of the DC-grade 2 and DC-grade 4 is four times of the above table while the frequency is 100 times and the breaking current capacity is four times of the above table while the frequency is 25 times.

Note e) The 2-polar series and 3-polar series connections are shown in the following diagram.

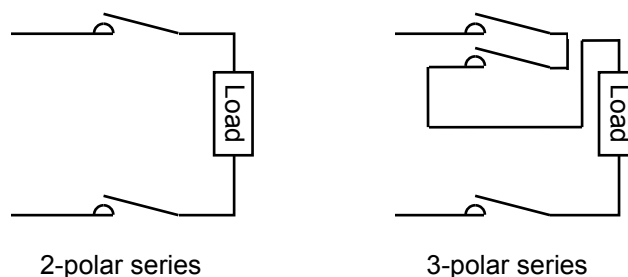

2.2 Test Sequence I

2.2.1 Verification of Temperature Rise and Dielectric Properties

These tests were conducted according to the test conditions indicated in Table 1 and Note a) to e). The temperature rise of each part met the standard criteria of temperature rise limit. Also the operations and dielectric properties after the temperature tests met the standard criteria.

Table 1

Item	Thermal Relay To Be Combined			Test Conditions				Results (Note a))							Judgment
	Model Name	Nominal Current of the Heater [A]	Setting Current Value [A]	Current [A]		Main Circuit Connection Wire Size [mm ²] (Note b))	Temperature Rise Value [K]				Operation	Dielectric Properties			
				Main Circuit	Auxiliary Circuit		Coil	Terminal		Contact		Impulse (Note d))	Power Frequency (Note d))		
								Main Circuit	Auxiliary Circuit	Main Circuit				Auxiliary Circuit	
Standard	-	-	-	-	-	100 or less	65 or less	65 or less	(Note c))		Three times opening and closing thermal No trip	7.3kV 1.2/50 μs x5 times (Note d))	1890V 5 seconds (Note d))		
MSO-T10	TH-T18	9	11	11	10	1.5	47	48	39	50	52	OK	OK	OK	OK
MSO-T12	TH-T18	11	13	13	10	2.5	47	56	41	55	54	OK	OK	OK	OK
MSO-T20	TH-T18	15	18	18	10	2.5	53	58	42	72	54	OK	OK	OK	OK
MSO-T21	TH-T25	15	18	18	10	2.5	43	51	41	43	47	OK	OK	OK	OK
MSO-T25	TH-T25	22	26	26	10	6	43	53	40	57	47	OK	OK	OK	OK
MSO-T35	TH-T50	29	34	34	10	10	67	47	30	58	42	OK	OK	OK	OK
MSO-T50	TH-T50	42	50	50	10	10	67	58	30	68	43	OK	OK	OK	OK
MSO-T65	TH-T65	54	65	65	10	16	57	49	25	60	42	OK	OK	OK	OK
MSO-T80	TH-T100	67	80	80	10	25	63	58	25	75	42	OK	OK	OK	OK
MSO-T100	TH-T100	82	100	100	10	35	51	56	34	70	49	OK	OK	OK	OK
S-T10	-	-	-	20	10	2.5	45	46	38	71	52	-	OK	OK	OK
S-T12	-	-	-	20	10	2.5	41	55	38	76	52	-	OK	OK	OK
S-T20	-	-	-	20	10	2.5	41	55	38	75	52	-	OK	OK	OK
S-T21	-	-	-	32	10	6	31	34	30	46	47	-	OK	OK	OK
S-T25	-	-	-	32	10	6	31	34	30	46	47	-	OK	OK	OK
S-T32	-	-	-	32	-	6	29	33	-	45	-	-	OK	OK	OK
S-T35	-	-	-	60	10	16	62	35	30	45	46	-	OK	OK	OK
S-T50	-	-	-	80	10	25	64	41	29	58	45	-	OK	OK	OK
S-T65	-	-	-	100	10	35	56	39	25	61	42	-	OK	OK	OK
S-T80	-	-	-	120	10	50	62	45	25	71	42	-	OK	OK	OK
S-T100	-	-	-	150	10	50	43	46	34	83	49	-	OK	OK	OK

Note a) The test of temperature rise value and operation was conducted by operating at an ambient temperature of 40°C, in open state with the iron plate mounted and by applying a voltage of 240V and a frequency of 60Hz to the operating coil.

Note b) The connection wire size of the auxiliary circuit: 1.5 mm²

Note c) The temperature rise value of the contacts was checked at a temperature that is not harmful to the surrounding components. (In short 100K)

Note d) The application points of the impulse withstand voltage performance and the power frequency withstand voltage performance were as follows. However in the power frequency withstand voltage test, (c) was not implemented.

Measurement Points: (a) Between all terminals of the main circuit and grounded metal body when the contact element was closed.

(b) Between one pole of the main circuit and all other poles connected altogether to the grounded metal body when the contact element was closed.

(c) Between the supply side terminals and the load side terminals of the main circuit when the contact element was opened.

(d) Between one circuit of the operating circuit and auxiliary circuit, and all other circuits/grounded metal body.

Note e) Number of Samples: 1 per machine

2.2.2 Verification of Operating Limits

(1) Operating Limits of the Magnetic Contactor

The operating voltage (hot condition) and open-circuit voltage after the temperature test met the standard criteria by operating and opening without hindrance in the set voltage.

Table 2

Model Name	Item Standard	Test Conditions and Results			Judgment
		Operating Voltage (40°C Hot)		Open-circuit Voltage (-5°C Cold)	
		Operation at 85% (170V or less) of the coil rated voltage	Operation at 110% of the coil rated voltage (Note a))	Open at 20 to 75% of the coil rated voltage (Note b))	
MSO-T10	50Hz	129	OK	90	OK
	60Hz	142	OK	107	OK
MSO-T12	50Hz	149	OK	95	OK
	60Hz	164	OK	109	OK
MSO-T20	50Hz	151	OK	96	OK
	60Hz	165	OK	112	OK
MSO-T21	50Hz	144	OK	104	OK
	60Hz	156	OK	115	OK
MSO-T25	50Hz	147	OK	108	OK
	60Hz	159	OK	118	OK
MSO-T35	50Hz	137	OK	107	OK
	60Hz	146	OK	117	OK
MSO-T50	50Hz	137	OK	107	OK
	60Hz	146	OK	117	OK
MSO-T65	50Hz	146	OK	85	OK
	60Hz	148	OK	77	OK
MSO-T80	50Hz	146	OK	85	OK
	60Hz	148	OK	77	OK
MSO-T100	50Hz	157	OK	100	OK
	60Hz	159	OK	93	OK
S-T10	50Hz	128	OK	89	OK
	60Hz	142	OK	106	OK
S-T12	50Hz	145	OK	90	OK
	60Hz	161	OK	107	OK
S-T20	50Hz	145	OK	90	OK
	60Hz	161	OK	108	OK
S-T21	50Hz	130	OK	103	OK
	60Hz	141	OK	112	OK
S-T25	50Hz	131	OK	104	OK
	60Hz	142	OK	114	OK
S-T32	50Hz	142	OK	96	OK
	60Hz	156	OK	108	OK
S-T35	50Hz	135	OK	107	OK
	60Hz	148	OK	117	OK
S-T50	50Hz	135	OK	107	OK
	60Hz	148	OK	117	OK
S-T65	50Hz	146	OK	85	OK
	60Hz	148	OK	77	OK
S-T80	50Hz	146	OK	85	OK
	60Hz	148	OK	77	OK
S-T100	50Hz	153	OK	98	OK
	60Hz	155	OK	91	OK

Note a) The operation at 110% of the coil rated voltage of standard value was possible at 264V 50Hz/60Hz.

Note b) The operation at 20 to 75% of the coil rated voltage of standard value was possible at 48V to 150V 50Hz/60Hz.

Note c) Number of Samples: 1 per machine

<Reference Test>

Coil characteristics (20°C cold condition)

Model Name	Input [VA]		Con- sumption Power [W]	Operating Voltage [V]		Coil Current [mA]		Operating Time [ms]					
	Instant	Usual		Operation	Open	Instant	Usual	Coil ON →			Coil OFF →		
								Main Contact ON	Auxiliary Contact a ON	Auxiliary Contact b OFF	Main Contact OFF	Auxiliary Contact a OFF	Auxiliary Contact b ON
S-T10	45	7	2.2	120 to 150	75 to 115	200	30	12 to 18	12 to 18	-	5 to 20	5 to 20	-
S-T12	45	7	2.2	120 to 150	75 to 115	200	30	12 to 18	12 to 18	9 to 16	5 to 20	5 to 20	7 to 22
S-T20	45	7	2.2	120 to 150	75 to 115	200	30	12 to 18	12 to 18	9 to 16	5 to 20	5 to 20	7 to 22
S-T21	75	7	2.4	125 to 155	80 to 115	340	30	13 to 20	13 to 20	8 to 14	5 to 15	5 to 15	8 to 18
S-T25	75	7	2.4	125 to 155	80 to 115	340	30	13 to 20	13 to 20	8 to 14	5 to 15	5 to 15	8 to 18
S-T32	55	4.5	1.8	125 to 155	80 to 115	250	20	15 to 22	-	-	5 to 15	-	-
S-T35	110	10	3.8	120 to 150	80 to 115	500	45	10 to 20	10 to 20	8 to 15	5 to 14	5 to 14	8 to 18
S-T50	110	10	3.8	120 to 150	80 to 115	500	45	10 to 20	10 to 20	8 to 15	5 to 14	5 to 14	8 to 18
S-T65	115	20	2.2	110 to 135	60 to 100	520	67	20 to 30	20 to 30	13 to 24	35 to 65	35 to 65	50 to 79
S-T80	115	20	2.2	110 to 135	60 to 100	520	67	20 to 30	20 to 30	13 to 24	35 to 65	35 to 65	50 to 79
S-T100	210	23	2.8	110 to 135	60 to 100	950	85	20 to 35	20 to 35	18 to 28	50 to 100	50 to 100	54 to 104

Note a) The above table shows the standard values of the properties of the 200VAC coil.

Note b) Coil current is the average value when 220V 60Hz was applied.

(2) Operating Limits of the Thermal Relay

These tests were conducted according to the test conditions indicated in Table 3 and Note a) to c) by using the magnetic contactor as shown in Table 3. The operation results were acceptable and met the standards.

Table 3

Item	Magnetic Contactor	Thermal Relay				Connection Wire Size [mm ²]	Conditions and Results				Judgment
		Model Name	Nominal Current of the Heater [A]	Trip Class	Settling Current Value [A]		Operations in a balanced circuit (ambient temperature: 20°C)				
							Condition A	Condition B	Condition C	Condition D	
Standard	-	-	-	-	-	-	The passage of electric current was 105% of the settling current. No operation when less than 2 hours	The passage of electric current was 120% of the settling current after condition A. Operation when less than 2 hours.	The passage of electric current was 100% of settling current, and after the constant temperature was maintained, the passage of current was 150% of the settling current. 10A: Less than 2 minutes 10: Less than 4 minutes	The passage of electric current was 720% of the settling current in cold conditions. 10A: 2<Tp≤10 seconds 10: 4<Tp≤10 seconds (Tp: Operating Time)	
Model Name											
MSO-T10	S-T10	TH-T18	9	10A	7	1.0	No operation	Operation when less than 2 hours	Operation between 30 and 76 seconds	Operation between 4.3 and 5.4 seconds	OK
					11	1.5	No operation	Operation when less than 2 hours	Operation between 18 and 42 seconds	Operation between 4.3 and 5.6 seconds	OK
MSO-T12	S-T12	TH-T18	11	10A	9	1.5	No operation	Operation when less than 2 hours	Operation between 15 and 34 seconds	Operation between 3.5 and 4.6 seconds	OK
					13	2.5	No operation	Operation when less than 2 hours	Operation between 16 and 32 seconds	Operation between 2.3 and 3.0 seconds	OK
MSO-T20	S-T20	TH-T18	15	10A	12	1.5	No operation	Operation when less than 2 hours	Operation between 15 and 36 seconds	Operation between 3.5 and 4.6 seconds	OK
					18	2.5	No operation	Operation when less than 2 hours	Operation between 16 and 29 seconds	Operation between 2.3 and 3.0 seconds	OK
MSO-T21	S-T21	TH-T25	15	10A	12	1.5	No operation	Operation when less than 2 hours	Operation between 24 and 41 seconds	Operation between 3.0 and 4.1 seconds	OK
					18	2.5	No operation	Operation when less than 2 hours	Operation between 12 and 34 seconds	Operation between 2.5 and 3.9 seconds	OK
MSO-T25	S-T25	TH-T25	22	10A	18	2.5	No operation	Operation when less than 2 hours	Operation between 21 and 59 seconds	Operation between 3.2 and 4.1 seconds	OK
					26	6.0	No operation	Operation when less than 2 hours	Operation between 14 and 35 seconds	Operation between 3.0 and 4.1 seconds	OK
MSO-T35	S-T35	TH-T50	29	10A	24	4.0	No operation	Operation when less than 2 hours	Operation between 25 and 51 seconds	Operation between 4.5 and 6.4 seconds	OK
					34	10	No operation	Operation when less than 2 hours	Operation between 38 and 65 seconds	Operation between 3.4 and 4.2 seconds	OK
MSO-T50	S-T50	TH-T50	42	10A	34	10	No operation	Operation when less than 2 hours	Operation between 31 and 50 seconds	Operation between 4.1 and 5.0 seconds	OK
					50	10	No operation	Operation when less than 2 hours	Operation between 25 and 42 seconds	Operation between 4.1 and 4.5 seconds	OK
MSO-T65	S-T65	TH-T65	54	10A	43	10	No operation	Operation when less than 2 hours	Operation between 69 and 83 seconds	Operation between 4.2 and 4.8 seconds	OK
					65	16	No operation	Operation when less than 2 hours	Operation between 41 and 55 seconds	Operation between 3.2 and 3.6 seconds	OK
MSO-T80	S-T80	TH-T100	67	10	54	25	No operation	Operation when less than 2 hours	Operation between 63 and 91 seconds	Operation between 7.2 and 7.9 seconds	OK
					80	35	No operation	Operation when less than 2 hours	Operation between 52 and 79 seconds	Operation between 6.2 and 6.7 seconds	OK
MSO-T100	S-T100	TH-T100	82	10A	65	16	No operation	Operation when less than 2 hours	Operation between 53 and 81 seconds	Operation between 4.8 and 5.9 seconds	OK
					100	35	No operation	Operation when less than 2 hours	Operation between 37 and 69 seconds	Operation between 2.9 and 3.5 seconds	OK

Note a) The operations were verified at an ambient temperature of 20°C, in open state with the iron plate mounted.

Note b) The settling current values were verified in terms of the minimum and maximum value of nominal current of the heater.

Note c) Number of Samples: 5 per machine

2.3 Test Sequence II

2.3.1 Test of Closed-circuit and Breaking Capacities

(1) Test of Closed-circuit Capacity

These tests were conducted according to the test conditions indicated in Table 4 and Note a) to c). No abnormalities such as welding of contacts were found, and the results met the standard criteria.

Table 4

Item	Rated Value (AC-grade 3)		Test Conditions (closed circuit)						Results	Judgment
	Voltage U _e [V]	Current I _e [A]	Voltage U [V]	Current I [A]	Power Factor cosφ	Operation Cycle [Times] (Note b)	ON time [seconds]	OFF time [seconds]		
Model Name	-	-	1.05 x U _e	10 x I _e	I _e ≤ 100A: 0.45 ± 0.05 I _e > 100A: 0.35 ± 0.05	50	0.05	10	Contact Welding	
S-T10	220	11	231	110	0.45	50	0.05	10	None	OK
	440	7	462	70	0.45	50	0.05	10	None	OK
S-T12	220	13	231	130	0.45	50	0.05	10	None	OK
	440	9	462	90	0.45	50	0.05	10	None	OK
S-T20	220	18	231	180	0.45	50	0.05	10	None	OK
	440	18	462	180	0.45	50	0.05	10	None	OK
S-T21	220	20	231	200	0.45	50	0.05	10	None	OK
	440	20	462	200	0.45	50	0.05	10	None	OK
S-T25	220	26	231	260	0.45	50	0.05	10	None	OK
	440	25	462	250	0.45	50	0.05	10	None	OK
S-T32	220	32	231	320	0.45	50	0.05	10	None	OK
	440	32	462	320	0.45	50	0.05	10	None	OK
S-T35	220	35	231	350	0.45	50	0.05	10	None	OK
	440	32	462	320	0.45	50	0.05	10	None	OK
S-T50	220	50	231	500	0.45	50	0.05	10	None	OK
	440	48	462	480	0.45	50	0.05	10	None	OK
S-T65	220	65	231	650	0.45	50	0.05	10	None	OK
	440	65	462	650	0.45	50	0.05	10	None	OK
S-T80	220	80	231	800	0.45	50	0.05	10	None	OK
	440	80	462	800	0.45	50	0.05	10	None	OK
S-T100	220	100	231	1000	0.45	50	0.05	10	None	OK
	440	93	462	930	0.45	50	0.05	10	None	OK

Note a) Main circuit frequency: 60Hz

Note b) Among 50 operating cycles, 110% of the rated value (264V 60Hz) was applied to the coil for 25 cycles, and 85% of the rated value (170V 60Hz) was applied to the coil for the other 25 cycles.

Note c) Number of Samples: 1 per machine

(2) Test of Closed-circuit and Breaking Capacities

These tests were conducted according to the test conditions indicated in Table 5 and Note a) to c) after the closed-circuit capacity test (1). No abnormalities such as welding of contacts and phase-to-phase short circuits were found, and the results met the standard criteria.

Table 5

Item	Rated Value (AC-grade 3)		Test Conditions (closed circuit and breaking capacity)						Results	Judgment
	Voltage Ue [V]	Current Ie [A]	Voltage Ur [V]	Current Ic [A]	Power Factor cosφ	Operation Cycle [Times]	ON time [seconds]	OFF time [seconds]		
Standard	-	-	1.05 x Ue	8 x Ie	Ie≤100A: 0.45±0.05 Ie>100A: 0.35±0.05	50	0.05	Ic≤100: 10 100<Ic≤200: 20 200<Ic≤300: 30 300<Ic≤400: 40 400<Ic≤600: 60 600<Ic≤800: 80	Contact Welding and Phase-to-phase Short-circuits	
Model Name										
S-T10	220	11	231	88	0.45	50	0.05	10	None	OK
	440	7	462	56	0.45	50	0.05	10	None	OK
S-T12	220	13	231	104	0.45	50	0.05	20	None	OK
	440	9	462	72	0.45	50	0.05	10	None	OK
S-T20	220	18	231	144	0.45	50	0.05	20	None	OK
	440	18	462	144	0.45	50	0.05	20	None	OK
S-T21	220	20	231	160	0.45	50	0.05	20	None	OK
	440	20	462	160	0.45	50	0.05	20	None	OK
S-T25	220	26	231	208	0.45	50	0.05	30	None	OK
	440	25	462	200	0.45	50	0.05	20	None	OK
S-T32	220	32	231	256	0.45	50	0.05	30	None	OK
	440	32	462	256	0.45	50	0.05	30	None	OK
S-T35	220	35	231	280	0.45	50	0.05	30	None	OK
	440	32	462	256	0.45	50	0.05	30	None	OK
S-T50	220	50	231	400	0.45	50	0.05	40	None	OK
	440	48	462	384	0.45	50	0.05	40	None	OK
S-T65	220	65	231	520	0.45	50	0.05	60	None	OK
	440	65	462	520	0.45	50	0.05	60	None	OK
S-T80	220	80	231	640	0.45	50	0.05	80	None	OK
	440	80	462	640	0.45	50	0.05	80	None	OK
S-T100	220	100	231	800	0.45	50	0.05	80	None	OK
	440	93	462	774	0.45	50	0.05	80	None	OK

Note a) Main circuit frequency: 60Hz

Note b) The operation was conducted by applying a voltage of 240V and a frequency 60Hz to the operating coil.

Note c) Number of Samples: 1 per machine

(3) Verification of the Switching Capacity and Reversibility

These tests were conducted according to the test conditions indicated in Table 6, 7 and Note a) to d). No abnormalities such as welding of contacts and phase-to-phase short circuits were found, and the results met the standard criteria.

Table 6

Item	Rated Value (AC-grade 4)		Test Conditions (closed circuit)						Results	Judgment
	Voltage Ue [V]	Current Ie [A]	Voltage Ur [V]	Current Ic [A]	Power Factor cosφ	Operation Cycle [Times]	ON time [seconds]	Down time [seconds]		
Standard	-	-	1.05 x Ue	12 x Ie	Ie≤100A: 0.45±0.05 Ie>100A: 0.35±0.05	50	0.05	10	Contact Welding and Phase-to-phase Short-circuits	
Model Name										
S-2 x T10	220	8	231	96	0.45	50	0.05	10	None	OK
	440	6	462	72	0.45	50	0.05	10	None	OK
S-2 x T12	220	11	231	132	0.45	50	0.05	10	None	OK
	440	9	462	108	0.45	50	0.05	10	None	OK
S-2 x T20	220	18	231	216	0.45	50	0.05	10	None	OK
	440	13	462	156	0.45	50	0.05	10	None	OK
S-2 x T21	220	18	231	216	0.45	50	0.05	10	None	OK
	440	13	462	156	0.45	50	0.05	10	None	OK
S-2 x T25	220	20	231	240	0.45	50	0.05	10	None	OK
	440	17	462	204	0.45	50	0.05	10	None	OK
S-2 x T35	220	26	231	312	0.45	50	0.05	10	None	OK
	440	24	462	288	0.45	50	0.05	10	None	OK
S-2 x T50	220	35	231	420	0.45	50	0.05	10	None	OK
	440	32	462	384	0.45	50	0.05	10	None	OK
S-2 x T65	220	50	231	600	0.45	50	0.05	10	None	OK
	440	47	462	564	0.45	50	0.05	10	None	OK
S-2 x T80	220	65	231	780	0.45	50	0.05	10	None	OK
	440	62	462	744	0.45	50	0.05	10	None	OK
S-2 x T100	220	80	231	960	0.45	50	0.05	10	None	OK
	440	75	462	900	0.45	50	0.05	10	None	OK

Table 7

Item	Rated Value (AC-grade 4)		Test Conditions (closed circuit and breaking capacity)						Results	Judgment	
	Voltage U _e [V]	Current I _e [A]	Voltage U _r [V]	Current I _c [A]	Power Factor cosφ	Operation Cycle [Times]		ON time [seconds]			Down time [seconds]
						Simultaneous Excitation Test					
Standard	-	-	1.05 x U _e	10 x I _e	I _e ≤ 100A 0.45 ± 0.05 I _e > 100A 0.35 ± 0.05	50	10	0.05	I _c ≤ 100: 10 100 < I _c ≤ 200: 20 200 < I _c ≤ 300: 30 300 < I _c ≤ 400: 40 400 < I _c ≤ 600: 60 600 < I _c ≤ 800: 80	Contact Welding and Phase-to-phase Short-circuits	
Model Name											
S-2 x T10	220	8	231	80	0.45	50	10	0.05	10	None	OK
	440	6	462	60	0.45	50	10	0.05	10	None	OK
S-2 x T12	220	11	231	110	0.45	50	10	0.05	20	None	OK
	440	9	462	90	0.45	50	10	0.05	10	None	OK
S-2 x T20	220	18	231	180	0.45	50	10	0.05	20	None	OK
	440	13	462	130	0.45	50	10	0.05	20	None	OK
S-2 x T21	220	18	231	180	0.45	50	10	0.05	20	None	OK
	440	13	462	130	0.45	50	10	0.05	20	None	OK
S-2 x T25	220	20	231	200	0.45	50	10	0.05	20	None	OK
	440	17	462	170	0.45	50	10	0.05	20	None	OK
S-2 x T35	220	26	231	260	0.45	50	10	0.05	30	None	OK
	440	24	462	240	0.45	50	10	0.05	30	None	OK
S-2 x T50	220	35	231	350	0.45	50	10	0.05	40	None	OK
	440	32	462	320	0.45	50	10	0.05	40	None	OK
S-2 x T65	220	50	231	500	0.45	50	10	0.05	60	None	OK
	440	47	462	470	0.45	50	10	0.05	60	None	OK
S-2 x T80	220	65	231	650	0.45	50	10	0.05	80	None	OK
	440	62	462	620	0.45	50	10	0.05	80	None	OK
S-2 x T100	220	80	231	800	0.45	50	10	0.05	80	None	OK
	440	75	462	750	0.45	50	10	0.05	80	None	OK

Note a) The test was conducted using reversible-type magnetic contactor.

Note b) The operation was conducted at main circuit frequency of 60Hz by applying a voltage of 240V and a frequency of 60Hz to the operating coil.

Note c) Close circuit A → Open circuit A, then immediately close circuit B → Open circuit B → Down time (above table) pause → Close circuit B → Open circuit B, then immediately close circuit A → Open circuit A → Down time (above table) pause, this makes 1 cycle. 50 cycles were performed in this way. Here, (1) "A" shows the forward rotation contactor and "B" shows the reverse rotation contactor. (2) "Immediately" refers to the shortest reversible exchange time.

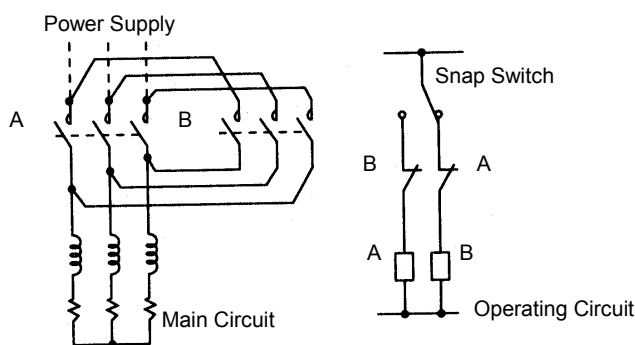

Note d) Number of Samples: 1 per machine

2.3.2 Verification of the Operating Performance

(1) Non-reversible

These tests were conducted according to the test conditions indicated in Table 8 and Note a) to c). No abnormalities such as welding of contacts and phase-to-phase short circuits were found, and the results met the standard criteria. After the test, the withstand voltage performance was checked by applying a voltage of 1000V and a frequency of 60Hz for 5 seconds. The results were acceptable.

Table 8

Item	Rated Value (AC-grade 3)		Test Conditions (closed circuit and breaking capacity)						Results		Judgment
	Voltage U_e [V]	Current I_e [A]	Voltage U_r [V]	Current I_c [A]	Power Factor $\cos\phi$	Operation Cycle [Times]	ON time [seconds]	OFF time [seconds]	Closed Circuit and Breaking Capacity	Withstand Voltage	
Standard	-	-	$1.05 \times U_e$	$2 \times I_e$	$I_e \leq 100A:$ 0.45 ± 0.05 $I_e > 100A:$ 0.35 ± 0.05	6000	0.05	$I_c \leq 100:$ 10 $100 < I_c \leq 200:$ 20	Contact Welding and Phase-to-phase Short-circuit	$2 \times U_e$ provided 1000V or higher 5 seconds	
Model Name											
S-T10	220	11	231	22	0.45	6000	0.05	10	None	OK	OK
	440	7	462	14	0.45	6000	0.05	10	None	OK	OK
S-T12	220	13	231	26	0.45	6000	0.05	10	None	OK	OK
	440	9	462	18	0.45	6000	0.05	10	None	OK	OK
S-T20	220	18	231	36	0.45	6000	0.05	10	None	OK	OK
	440	18	462	36	0.45	6000	0.05	10	None	OK	OK
S-T21	220	20	231	40	0.45	6000	0.05	10	None	OK	OK
	440	20	462	40	0.45	6000	0.05	10	None	OK	OK
S-T25	220	26	231	52	0.45	6000	0.05	10	None	OK	OK
	440	25	462	50	0.45	6000	0.05	10	None	OK	OK
S-T32	220	32	231	64	0.45	6000	0.05	10	None	OK	OK
	440	32	462	64	0.45	6000	0.05	10	None	OK	OK
S-T35	220	35	231	70	0.45	6000	0.05	10	None	OK	OK
	440	32	462	64	0.45	6000	0.05	10	None	OK	OK
S-T50	220	50	231	100	0.45	6000	0.05	10	None	OK	OK
	440	48	462	96	0.45	6000	0.05	10	None	OK	OK
S-T65	220	65	231	130	0.45	6000	0.05	20	None	OK	OK
	440	65	462	130	0.45	6000	0.05	20	None	OK	OK
S-T80	220	80	231	160	0.45	6000	0.05	20	None	OK	OK
	440	80	462	160	0.45	6000	0.05	20	None	OK	OK
S-T100	220	100	231	200	0.45	6000	0.05	20	None	OK	OK
	440	93	462	186	0.45	6000	0.05	20	None	OK	OK

Note a) Main circuit frequency: 60Hz

Note b) The operation was conducted by applying a voltage of 240V and a frequency of 60Hz to the operating coil.

Note c) Number of Samples: 1 per machine

(2) Reversible

These tests were conducted according to the test conditions indicated in Table 9 and Note a) to e). No abnormalities such as welding of contacts and phase-to-phase short circuits were found, and the results met the standard criteria. After the test, the withstand voltage performance was checked by applying a voltage of 1000V and a frequency of 60Hz for 5 seconds. The results were acceptable.

Table 9

Item	Rated Value (AC-grade 4)		Test Conditions (closed circuit and breaking capacity)						Results		Judgment
	Voltage U _e [V]	Current I _e [A]	Voltage U _r [V]	Current I _c [A]	Power Factor cosφ	Operation Cycle [Times] (Note d))	ON time [seconds]	OFF time [seconds]	Closed Circuit and Breaking Capacity	Withstand Voltage	
Standard	-	-	1.05 x U _e	6 x I _e	I _e ≤ 100A: 0.45 ± 0.05 I _e > 100A: 0.35 ± 0.05	6000	0.05	I _c ≤ 100: 10 100 < I _c ≤ 200: 20 200 < I _c ≤ 300: 30 300 < I _c ≤ 400: 40 400 < I _c ≤ 600: 60	Contact Welding and Phase-to-phase Short-circuit	2 x U _e Provided 1000V or higher 5 seconds	
Model Name											
S-2 x T10	220	8	231	48	0.45	6000	0.05	10	None	OK	OK
	440	6	462	36	0.45	6000	0.05	10	None	OK	OK
S-2 x T12	220	11	231	66	0.45	6000	0.05	10	None	OK	OK
	440	9	462	54	0.45	6000	0.05	10	None	OK	OK
S-2 x T20	220	18	231	108	0.45	6000	0.05	20	None	OK	OK
	440	13	462	78	0.45	6000	0.05	10	None	OK	OK
S-2 x T21	220	18	231	108	0.45	6000	0.05	20	None	OK	OK
	440	13	462	78	0.45	6000	0.05	10	None	OK	OK
S-2 x T25	220	20	231	120	0.45	6000	0.05	20	None	OK	OK
	440	17	462	102	0.45	6000	0.05	20	None	OK	OK
S-2 x T32	220	26	231	156	0.45	6000	0.05	20	None	OK	OK
	440	24	462	144	0.45	6000	0.05	20	None	OK	OK
S-2 x T35	220	26	231	156	0.45	6000	0.05	20	None	OK	OK
	440	24	462	144	0.45	6000	0.05	20	None	OK	OK
S-2 x T50	220	35	231	210	0.45	6000	0.05	30	None	OK	OK
	440	32	462	192	0.45	6000	0.05	20	None	OK	OK
S-2 x T65	220	50	231	300	0.45	6000	0.05	30	None	OK	OK
	440	47	462	282	0.45	6000	0.05	30	None	OK	OK
S-2 x T80	220	65	231	390	0.45	6000	0.05	40	None	OK	OK
	440	62	462	372	0.45	6000	0.05	40	None	OK	OK
S-2 x T100	220	80	231	480	0.45	6000	0.05	60	None	OK	OK
	440	75	462	450	0.45	6000	0.05	60	None	OK	OK

Note a) The test was conducted using reversible-type magnetic contactor.

Note b) Main circuit frequency: 60Hz

Note c) The operation was conducted by applying a voltage of 240V and frequency of 60Hz to the operating coil.

Note d) The operation was performed based on the cycle mentioned in Note c) of 2.3.1 (3).

Note e) Number of Samples: 1 per machine

2.4 Test Sequence III

2.4.1 Performance under Short-circuit Conditions

These tests were conducted according to the test conditions indicated in Table 10 and Note a) to d). There was no damage to the conductors and terminals. The leakage detection fuse was not melted, and the results were acceptable.

Table 10

Model Name	Item Thermal Relay Model Name and Nominal Current of the Heater Standard	Rated Current of SCPD [A] (Note a))	Rated Value (AC-grade 3)		Test Conditions				Results			Judgment
			Voltage U _e [V]	Current I _e [A]	Voltage [V]	Current I [kA] (Note c))	Power Factor cosφ (Note d))	Number of Samples [machine]	O or CO Operation	Conductor/Terminal Damage	Melting of the Leakage Detection Fuse	
									(Note b))	None	None	
MSO-T10	TH-T18 9A	20	220/440	11/7	440	1	0.95	1	O	None	None	OK
								1	CO	None	None	
MSO-T12	TH-T18 11A	25	220/440	13/9	440	1	0.95	1	O	None	None	OK
								1	CO	None	None	
MSO-T20	TH-T18 15A	32	220/440	18/18	440	3	0.9	1	O	None	None	OK
								1	CO	None	None	
MSO-T21	TH-T25 15A	32	220/440	18/18	440	3	0.9	1	O	None	None	OK
								1	CO	None	None	
MSO-T25	TH-T25 22A	50	220/440	26/25	440	3	0.9	1	O	None	None	OK
								1	CO	None	None	
MSO-T35	TH-T50 29A	63	220/440	34/32	440	3	0.9	1	O	None	None	OK
								1	CO	None	None	
MSO-T50	TH-T50 42A	100	220/440	50/48	440	3	0.9	1	O	None	None	OK
								1	CO	None	None	
MSO-T65	TH-T65 54A	100	220/440	65/65	440	5	0.7	1	O	None	None	OK
								1	CO	None	None	
MSO-T80	TH-T100 67A	125	220/440	80/80	440	5	0.7	1	O	None	None	OK
								1	CO	None	None	
MSO-T100	TH-T100 82A	160	220/440	100/93	440	5	0.7	1	O	None	None	OK
								1	CO	None	None	
S-T10	-	40	220/440	11/7	440	1	0.95	1	O	None	None	OK
								1	CO	None	None	
S-T12	-	40	220/440	13/9	440	1	0.95	1	O	None	None	OK
								1	CO	None	None	
S-T20	-	40	220/440	18/18	440	3	0.9	1	O	None	None	OK
								1	CO	None	None	
S-T21	-	80	220/440	20/20	440	3	0.9	1	O	None	None	OK
								1	CO	None	None	
S-T25	-	80	220/440	26/25	440	3	0.9	1	O	None	None	OK
								1	CO	None	None	
S-T32	-	80	220/440	32/32	440	3	0.9	1	O	None	None	OK
								1	CO	None	None	
S-T35	-	100	220/440	35/32	440	3	0.9	1	O	None	None	OK
								1	CO	None	None	
S-T50	-	100	220/440	50/48	440	3	0.9	1	O	None	None	OK
								1	CO	None	None	
S-T65	-	100	220/440	65/65	440	5	0.7	1	O	None	None	OK
								1	CO	None	None	
S-T80	-	125	220/440	80/80	440	5	0.7	1	O	None	None	OK
								1	CO	None	None	
S-T100	-	160	220/440	100/93	440	5	0.7	1	O	None	None	OK
								1	CO	None	None	

Note a) SCPD: Short Circuit Protection Device

Note b) O operation: Breaking of the circuit by the SCPD resulting from closing the circuit on the equipment under test which is in the closed position.

CO operation: Breaking of the circuit by the SCPD resulting from closing the circuit by the equipment under test.

Note c) The test current specified in the standards for rated operating current was as follows. (I_e indicates the maximum current applied to the motor)

When $1 < I_e \leq 16$: 1 kA

When $16 < I_e \leq 63$: 3 kA

When $63 < I_e \leq 125$: 5 kA

Note d) The power factor specified in the standards for test current was as follows.

When $I \leq 1.5$ kA: 0.95 ± 0.05

When $1.5 \text{ kA} < I \leq 3$ kA: 0.9 ± 0.05

When $4.5 \text{ kA} < I \leq 6$ kA: 0.7 ± 0.05

2.5 Test Sequence IV

2.5.1 Verification of Ability of Contactors to Withstand Overload Currents

The current indicated in Table 11 was applied for 10 seconds in closed circuit conditions of the magnetic contactor. All the parts met the standard criteria without abnormality.

Table 11

Item Standard Model Name	Rated Current [A]	Test Conditions		Results	Judgment
		Current [A]	Current Passage Time [seconds]		
	Rated Operating Current (AC-3)	$I_e \leq 630A: 8 \times I_e$ $I_e > 630A: 6 \times I_e$	10	Abnormality in the part	
S-T10	11	88	10	None	OK
S-T12	13	104	10	None	OK
S-T20	18	144	10	None	OK
S-T21	20	160	10	None	OK
S-T25	26	208	10	None	OK
S-T32	32	256	10	None	OK
S-T35	35	280	10	None	OK
S-T50	50	400	10	None	OK
S-T65	65	520	10	None	OK
S-T80	80	640	10	None	OK
S-T100	100	800	10	None	OK

Note a) The test was conducted only for the magnetic contactor.

Note b) Number of Samples: 1 per machine

2.6 Test Sequence V

2.6.1 Verification of Mechanical Properties of Terminals

(1) Tests of Mechanical Strength of Terminals

The crimp terminal indicated in Table 12 was tightened with the following tightening torques, and was tested by connection and disconnection 5 times. All the parts met the standard criteria without looseness or damage.

Table 12

Item Standard Model Name	Target Terminal Position	Crimp Terminal Size	Manufacturer Standard Tightening Torque [N·m]	Tested Tightening Torque [N·m]	Results	Judgment
	-	Conductor of the Maximum Cross-Sectional Area	-	110% of the Manufacturer Standard Tightening Torque (Note a))	Looseness or Damage to the Part	
MSO-T10	S-T10: 1/L1	2-3.5	0.9 to 1.5	1.65	None	OK
	TH-T18: 6/T3	2-3.5	0.9 to 1.5	1.65	None	OK
MSO-T12	S-T12: 1/L1	2-3.5	0.9 to 1.5	1.65	None	OK
	TH-T18: 6/T3	2-3.5	0.9 to 1.5	1.65	None	OK
MSO-T20	S-T20: 1/L1	2-3.5	0.9 to 1.5	1.65	None	OK
	TH-T18: 6/T3	2-3.5	0.9 to 1.5	1.65	None	OK
MSO-T21	S-T21: 1/L1	5.5-4	1.2 to 1.9	2.09	None	OK
	TH-T25: 6/T3	5.5-4	1.2 to 1.9	2.09	None	OK
MSO-T25	S-T25: 1/L1	5.5-4	1.2 to 1.9	2.09	None	OK
	TH-T25: 6/T3	5.5-4	1.2 to 1.9	2.09	None	OK
MSO-T35	S-T35: 1/L1	22-S5	2.0 to 3.3	3.63	None	OK
	TH-T50: 6/T3	14-5	2.0 to 3.3	3.63	None	OK
MSO-T50	S-T50: 1/L1	22-S5	2.0 to 3.3	3.63	None	OK
	TH-T50: 6/T3	14-5	2.0 to 3.3	3.63	None	OK
MSO-T65	S-T65: 1/L1	60-S6	3.5 to 5.7	6.27	None	OK
	TH-T65: 6/T3	22-6	3.5 to 5.7	6.27	None	OK
MSO-T80	S-T80: 1/L1	60-S6	3.5 to 5.7	6.27	None	OK
	TH-T100: 6/T3	38-S6	3.5 to 5.7	6.27	None	OK
MSO-T100	S-T100: 1/L1	60-6	3.5 to 5.7	6.27	None	OK
	TH-T100: 6/T3	38-S6	3.5 to 5.7	6.27	None	OK
S-T10	2/T1, 6/T3	2-3.5	0.9 to 1.5	1.65	None	OK
S-T12	2/T1, 6/T3	2-3.5	0.9 to 1.5	1.65	None	OK
S-T20	2/T1, 6/T3	2-3.5	0.9 to 1.5	1.65	None	OK
S-T21	2/T1, 6/T3	5.5-4	1.2 to 1.9	2.09	None	OK
S-T25	2/T1, 6/T3	5.5-4	1.2 to 1.9	2.09	None	OK
S-T32	2/T1, 6/T3	5.5-4	1.2 to 1.9	2.09	None	OK
S-T35	2/T1, 6/T3	22-S5	2.0 to 3.3	3.63	None	OK
S-T50	2/T1, 6/T3	22-S5	2.0 to 3.3	3.63	None	OK
S-T65	2/T1, 6/T3	60-S6	3.5 to 5.7	6.27	None	OK
S-T80	2/T1, 6/T3	60-S6	3.5 to 5.7	6.27	None	OK
S-T100	2/T1, 6/T3	60-6	3.5 to 5.7	6.27	None	OK

Note a) The test was conducted by applying 110% of the maximum value of the manufacturer standard tightening torque.

Note b) Number of Samples: 1 per machine

(2) Flexion and Pull-out Tests

In the flexion tests, the wire was rotated 135 times continuously by placing weight on its pointed end under the conditions (the following tightening torques were checked by using the minimum value of the manufacturer standard tightening torque) indicated in Tables 13-1 and 13-2. The results met the standard criteria without pullout or breaking of the conductor. Then, the pull-out strength indicated in Tables 13-1 and 13-2 was applied for 1 minute. The results met the standard criteria without pullout or breaking of the conductor.

Table 13-1

Item	Target Terminal Position	Screw Size	Wire Specifications		Number of Connections	Manufacturer Standard Tightening Torque [N·m]	Tested Tightening Torque [N·m]	Bushing Hole Diameter [mm]	Height [mm]	Weight [kg]	Pulling Force [N]	Judgment
			Type	Size								
Standard	-	-	-	-	Maximum Number of Connections	-	Specified Tightening Torque	0.75mm ² : 6.5 1.25mm ² : 6.5 2.5mm ² : 9.5 4mm ² : 9.5 6mm ² : 9.5 14mm ² : 13.0 16mm ² : 13.0 φ1.6: 9.5 φ2: 9.5 φ2.6: 9.5 φ3.6: 13.0	0.75mm ² : 260 1.25mm ² : 260 2.5mm ² : 280 4mm ² : 280 6mm ² : 280 14mm ² : 300 16mm ² : 300 φ1.6: 280 φ2: 280 φ2.6: 280 φ3.6: 300	0.75mm ² : 0.4 1.25mm ² : 0.4 2.5mm ² : 0.7 4mm ² : 0.9 6mm ² : 1.4 14mm ² : 2.9 16mm ² : 2.9 φ1.6: 0.7 φ2: 0.9 φ2.6: 1.4 φ3.6: 2.9	0.75mm ² : 30 1.25mm ² : 40 2.5mm ² : 50 4mm ² : 60 6mm ² : 80 14mm ² : 100 16mm ² : 100 φ1.6: 50 φ2: 60 φ2.6: 80 φ3.6: 100	Pullout or Breaking of Conductor
Model Name												
MSO-T10	2/T1 (S-T10)	M3.5	Stranded Wire	0.75mm ² 2.5mm ²	2 2	0.9 to 1.5 0.9 to 1.5	0.9 0.9	6.5 9.5	260 280	0.4 0.7	30 50	OK OK
			Single Wire	φ1.6	2	0.9 to 1.5	0.9	9.5	280	0.7	50	OK
	6/T3 (TH-T18)	M3.5	Stranded Wire	0.75mm ² 2.5mm ²	2 2	0.9 to 1.5 0.9 to 1.5	0.9 0.9	6.5 9.5	260 280	0.4 0.7	30 50	OK OK
			Single Wire	φ1.6	2	0.9 to 1.5	0.9	9.5	280	0.7	50	OK
MSO-T12	2/T1 (S-T12)	M3.5	Stranded Wire	0.75mm ² 2.5mm ²	2 2	0.9 to 1.5 0.9 to 1.5	0.9 0.9	6.5 9.5	260 280	0.4 0.7	30 50	OK OK
			Single Wire	φ1.6	2	0.9 to 1.5	0.9	9.5	280	0.7	50	OK
	6/T3 (TH-T18)	M3.5	Stranded Wire	0.75mm ² 2.5mm ²	2 2	0.9 to 1.5 0.9 to 1.5	0.9 0.9	6.5 9.5	260 280	0.4 0.7	30 50	OK OK
			Single Wire	φ1.6	2	0.9 to 1.5	0.9	9.5	280	0.7	50	OK
MSO-T20	2/T1 (S-T20)	M3.5	Stranded Wire	0.75mm ² 2.5mm ²	2 2	0.9 to 1.5 0.9 to 1.5	0.9 0.9	6.5 9.5	260 280	0.4 0.7	30 50	OK OK
			Single Wire	φ1.6	2	0.9 to 1.5	0.9	9.5	280	0.7	50	OK
	6/T3 (TH-T18)	M3.5	Stranded Wire	0.75mm ² 2.5mm ²	2 2	0.9 to 1.5 0.9 to 1.5	0.9 0.9	6.5 9.5	260 280	0.4 0.7	30 50	OK OK
			Single Wire	φ1.6	2	0.9 to 1.5	0.9	9.5	280	0.7	50	OK
MSO-T21	2/T1 (S-T21)	M4	Stranded Wire	1.25mm ² 6mm ²	2 2	1.2 to 1.9 1.2 to 1.9	1.2 1.2	6.5 9.5	260 280	0.4 1.4	40 80	OK OK
			Single Wire	φ1.6 φ2.6	2 2	1.2 to 1.9 1.2 to 1.9	1.2 1.2	9.5 9.5	280 280	0.7 1.4	50 80	OK OK
			Stranded Wire	1.25mm ² 6mm ²	2 2	1.2 to 1.9 1.2 to 1.9	1.2 1.2	6.5 9.5	260 280	0.4 1.4	40 80	OK OK
	6/T3 (TH-T25)	M4	Single Wire	φ1.6 φ2.6	2 2	1.2 to 1.9 1.2 to 1.9	1.2 1.2	9.5 9.5	280 280	0.7 1.4	50 80	OK OK
			Stranded Wire	1.25mm ² 6mm ²	2 2	1.2 to 1.9 1.2 to 1.9	1.2 1.2	6.5 9.5	260 280	0.4 1.4	40 80	OK OK
			Single Wire	φ1.6 φ2.6	2 2	1.2 to 1.9 1.2 to 1.9	1.2 1.2	9.5 9.5	280 280	0.7 1.4	50 80	OK OK
MSO-T25	2/T1 (S-T25)	M4	Stranded Wire	1.25mm ² 6mm ²	2 2	1.2 to 1.9 1.2 to 1.9	1.2 1.2	6.5 9.5	260 280	0.4 1.4	40 80	OK OK
			Single Wire	φ1.6 φ2.6	2 2	1.2 to 1.9 1.2 to 1.9	1.2 1.2	9.5 9.5	280 280	0.7 1.4	50 80	OK OK
			Stranded Wire	1.25mm ² 6mm ²	2 2	1.2 to 1.9 1.2 to 1.9	1.2 1.2	6.5 9.5	260 280	0.4 1.4	40 80	OK OK
	6/T3 (TH-T25)	M4	Single Wire	φ1.6 φ2.6	2 2	1.2 to 1.9 1.2 to 1.9	1.2 1.2	9.5 9.5	280 280	0.7 1.4	50 80	OK OK
			Stranded Wire	1.25mm ² 6mm ²	2 2	1.2 to 1.9 1.2 to 1.9	1.2 1.2	6.5 9.5	260 280	0.4 1.4	40 80	OK OK
			Single Wire	φ1.6 φ2.6	2 2	1.2 to 1.9 1.2 to 1.9	1.2 1.2	9.5 9.5	280 280	0.7 1.4	50 80	OK OK
MSO-T35	2/T1 (S-T35)	M5	Stranded Wire	1.25mm ² 16mm ²	2 2	2.0 to 3.3 2.0 to 3.3	2.0 2.0	6.5 13.0	260 300	0.4 2.9	40 100	OK OK
			Single Wire	φ1.6 φ3.6	2 2	2.0 to 3.3 2.0 to 3.3	2.0 2.0	9.5 13.0	280 300	0.7 2.9	50 100	OK OK
			Stranded Wire	4mm ² 14mm ²	2 2	2.0 to 3.3 2.0 to 3.3	2.0 2.0	9.5 13.0	280 300	0.9 2.9	60 100	OK OK
	6/T3 (TH-T50)	M5	Single Wire	φ2 φ3.6	2 2	2.0 to 3.3 2.0 to 3.3	2.0 2.0	9.5 13.0	280 300	0.9 2.9	60 100	OK OK
			Stranded Wire	4mm ² 14mm ²	2 2	2.0 to 3.3 2.0 to 3.3	2.0 2.0	9.5 13.0	280 300	0.9 2.9	60 100	OK OK
			Single Wire	φ2 φ3.6	2 2	2.0 to 3.3 2.0 to 3.3	2.0 2.0	9.5 13.0	280 300	0.9 2.9	60 100	OK OK
MSO-T50	2/T1 (S-T50)	M5	Stranded Wire	1.25mm ² 16mm ²	2 2	2.0 to 3.3 2.0 to 3.3	2.0 2.0	6.5 13.0	260 300	0.4 2.9	40 100	OK OK
			Single Wire	φ1.6 φ3.6	2 2	2.0 to 3.3 2.0 to 3.3	2.0 2.0	9.5 13.0	280 300	0.7 2.9	50 100	OK OK
			Stranded Wire	4mm ² 14mm ²	2 2	2.0 to 3.3 2.0 to 3.3	2.0 2.0	9.5 13.0	280 300	0.9 2.9	60 100	OK OK
	6/T3 (TH-T50)	M5	Single Wire	φ2 φ3.6	2 2	2.0 to 3.3 2.0 to 3.3	2.0 2.0	9.5 13.0	280 300	0.9 2.9	60 100	OK OK
			Stranded Wire	4mm ² 14mm ²	2 2	2.0 to 3.3 2.0 to 3.3	2.0 2.0	9.5 13.0	280 300	0.9 2.9	60 100	OK OK
			Single Wire	φ2 φ3.6	2 2	2.0 to 3.3 2.0 to 3.3	2.0 2.0	9.5 13.0	280 300	0.9 2.9	60 100	OK OK

Note a) Since MSO-T65 or higher models cannot be connected to the unprocessed exposed conductor, this evaluation is not applicable.

Table 13-2

Item	Target Terminal Position	Screw Size	Wire Specification		Number of Connections	Manufacturer Standard Tightening Torque [N·m]	Tested Tightening Torque [N·m]	Bushing Hole Diameter [mm]	Height [mm]	Weight [kg]	Pulling Force [N]	Judgment
			Type	Size								
Standard	-	-	-	-	Maximum Number of Connections	-	Specified Tightening Torque	0.75mm ² : 6.5 1.25mm ² : 6.5 2.5mm ² : 9.5 16mm ² : 13.0 φ1.6: 9.5 φ3.6: 13.0	0.75mm ² : 260 1.25mm ² : 260 2.5mm ² : 280 16mm ² : 300 φ1.6: 280 φ3.6: 300	0.75mm ² : 0.4 1.25mm ² : 0.4 2.5mm ² : 0.7 16mm ² : 2.9 φ1.6: 0.7 φ3.6: 2.9	0.75mm ² : 30 1.25mm ² : 40 2.5mm ² : 50 16mm ² : 100 φ1.6: 50 φ3.6: 100	Pullout or Breaking of Conductor
Model Name												
S-T10	2/T1	M3.5	Stranded Wire	0.75mm ²	2	0.9 to 1.5	0.9	6.5	260	0.4	30	OK
			Stranded Wire	2.5mm ²	2	0.9 to 1.5	0.9	9.5	280	0.7	50	OK
			Single Wire	φ1.6	2	0.9 to 1.5	0.9	9.5	280	0.7	50	OK
	6/T3	M3.5	Stranded Wire	0.75mm ²	2	0.9 to 1.5	0.9	6.5	260	0.4	30	OK
			Stranded Wire	2.5mm ²	2	0.9 to 1.5	0.9	9.5	280	0.7	50	OK
			Single Wire	φ1.6	2	0.9 to 1.5	0.9	9.5	280	0.7	50	OK
S-T12	2/T1	M3.5	Stranded Wire	0.75mm ²	2	0.9 to 1.5	0.9	6.5	260	0.4	30	OK
			Stranded Wire	2.5mm ²	2	0.9 to 1.5	0.9	9.5	280	0.7	50	OK
			Single Wire	φ1.6	2	0.9 to 1.5	0.9	9.5	280	0.7	50	OK
	6/T3	M3.5	Stranded Wire	0.75mm ²	2	0.9 to 1.5	0.9	6.5	260	0.4	30	OK
			Stranded Wire	2.5mm ²	2	0.9 to 1.5	0.9	9.5	280	0.7	50	OK
			Single Wire	φ1.6	2	0.9 to 1.5	0.9	9.5	280	0.7	50	OK
S-T20	2/T1	M3.5	Stranded Wire	0.75mm ²	2	0.9 to 1.5	0.9	6.5	260	0.4	30	OK
			Stranded Wire	2.5mm ²	2	0.9 to 1.5	0.9	9.5	280	0.7	50	OK
			Single Wire	φ1.6	2	0.9 to 1.5	0.9	9.5	280	0.7	50	OK
	6/T3	M3.5	Stranded Wire	0.75mm ²	2	0.9 to 1.5	0.9	6.5	260	0.4	30	OK
			Stranded Wire	2.5mm ²	2	0.9 to 1.5	0.9	9.5	280	0.7	50	OK
			Single Wire	φ1.6	2	0.9 to 1.5	0.9	9.5	280	0.7	50	OK
S-T21	2/T1	M4	Stranded Wire	1.25mm ²	2	1.2 to 1.9	1.2	6.5	260	0.4	40	OK
			Stranded Wire	6mm ²	2	1.2 to 1.9	1.2	9.5	280	1.4	80	OK
			Single Wire	φ1.6	2	1.2 to 1.9	1.2	9.5	280	0.7	50	OK
	6/T3	M4	Stranded Wire	1.25mm ²	2	1.2 to 1.9	1.2	6.5	260	0.4	40	OK
			Stranded Wire	6mm ²	2	1.2 to 1.9	1.2	9.5	280	1.4	80	OK
			Single Wire	φ1.6	2	1.2 to 1.9	1.2	9.5	280	0.7	50	OK
S-T25	2/T1	M4	Stranded Wire	1.25mm ²	2	1.2 to 1.9	1.2	6.5	260	0.4	40	OK
			Stranded Wire	6mm ²	2	1.2 to 1.9	1.2	9.5	280	1.4	80	OK
			Single Wire	φ1.6	2	1.2 to 1.9	1.2	9.5	280	0.7	50	OK
	6/T3	M4	Stranded Wire	1.25mm ²	2	1.2 to 1.9	1.2	6.5	260	0.4	40	OK
			Stranded Wire	6mm ²	2	1.2 to 1.9	1.2	9.5	280	1.4	80	OK
			Single Wire	φ1.6	2	1.2 to 1.9	1.2	9.5	280	0.7	50	OK
S-T32	2/T1	M4	Stranded Wire	1.25mm ²	2	1.2 to 1.9	1.2	6.5	260	0.4	40	OK
			Stranded Wire	6mm ²	2	1.2 to 1.9	1.2	9.5	280	1.4	80	OK
			Single Wire	φ1.6	2	1.2 to 1.9	1.2	9.5	280	0.7	50	OK
	6/T3	M4	Stranded Wire	1.25mm ²	2	1.2 to 1.9	1.2	6.5	260	0.4	40	OK
			Stranded Wire	6mm ²	2	1.2 to 1.9	1.2	9.5	280	1.4	80	OK
			Single Wire	φ1.6	2	1.2 to 1.9	1.2	9.5	280	0.7	50	OK
S-T35	2/T1	M5	Stranded Wire	1.25mm ²	2	2.0 to 3.3	2.0	6.5	260	0.4	40	OK
			Stranded Wire	16mm ²	2	2.0 to 3.3	2.0	13.0	300	2.9	100	OK
			Single Wire	φ1.6	2	2.0 to 3.3	2.0	9.5	280	0.7	50	OK
	6/T3	M5	Stranded Wire	1.25mm ²	2	2.0 to 3.3	2.0	6.5	260	0.4	40	OK
			Stranded Wire	16mm ²	2	2.0 to 3.3	2.0	13.0	300	2.9	100	OK
			Single Wire	φ1.6	2	2.0 to 3.3	2.0	9.5	280	0.7	50	OK
S-T50	2/T1	M5	Stranded Wire	1.25mm ²	2	2.0 to 3.3	2.0	6.5	260	0.4	40	OK
			Stranded Wire	16mm ²	2	2.0 to 3.3	2.0	13.0	300	2.9	100	OK
			Single Wire	φ1.6	2	2.0 to 3.3	2.0	9.5	280	0.7	50	OK
	6/T3	M5	Stranded Wire	1.25mm ²	2	2.0 to 3.3	2.0	6.5	260	0.4	40	OK
			Stranded Wire	16mm ²	2	2.0 to 3.3	2.0	13.0	300	2.9	100	OK
			Single Wire	φ1.6	2	2.0 to 3.3	2.0	9.5	280	0.7	50	OK

Note a) Since S-T65 or higher models cannot be connected to the unprocessed exposed conductor, this evaluation is not applicable.

Special Magnetic Contactor

■ DC-operated Magnetic Contactor <SD-T Type>

The SD-T type DC operating magnetic contactor is used to supply DC to the electromagnetic portion of S-T type magnetic contactor.

1. Structure

Since the SD-T12 to T100 type electromagnets limit the current with just the resistor of the coil by directly applying all the voltage, their operation is stable with no inrush current. The SD-T12 to T32 electromagnets are high efficiency polarized electromagnets that combine the coil and permanent magnet.

2. Rating

Contact rated value is the same as that of AC operating S-T type.

3. Type Test

Applicable Standard JIS C8201-1 (2007) Low voltage switchgear and control gear
Part 1: General Rule
 JIS C8201-4-1 (2010) Low voltage switchgear and control gear
Part 4: Contactor and Motor Starter
Section 1: Electro-mechanical Contactor and Motor Starter

3.1 Type Tests and Test Sequences

Test Sequences	Test Name	Test Conditions
a) Sequence I	1) Verification of temperature rise	According to the JIS C8201-4-1 9.3.3.3 "Temperature Rise".
	2) Verification of operation and operating limits	According to the JIS C8201-4-1 9.3.3.2 "Operating Limit".
	3) Verification of dielectric properties	According to the JIS C8201-4-1 9.3.3.4 "Dielectric Properties".
b) Sequence II	1) Verification of rated close-circuit and breaking capacity Verification of switching capacity and reversibility	According to the JIS C8201-4-1 9.3.3.5 "Closed-circuit and Breaking Capacity".
	2) Verification of conventional operating performance	According to the JIS C8201-4-1 9.3.3.6 "Operating Performance Capability".
c) Sequence III	1) Performance under short-circuit conditions	According to the JIS C8201-4-1 9.3.4 "Performance under Short-circuit Conditions".
d) Sequence IV	1) Verification of ability of contactors to withstand overload currents	According to the JIS C8201-4-1 9.3.5 "Ability of Contactors to Withstand Overload Currents".
e) Sequence V	1) Verification of mechanical properties of terminals	According to the JIS C8201-1 8.2.4 "Mechanical Properties of Terminals".

Note Tests were conducted with the following coil designation:
Test Sequence I : SD-T12 to SD-T32: 24VDC, 100VDC
 SD-T35 to SD-T100: 24VDC
Test Sequence II to V : 24VDC

3.2 Test Sequence I

3.2.1 Verification of Temperature Rise and Dielectric Properties

For the temperature rise, these tests were conducted according to the test conditions indicated in Table 1 and Note a) to d), and the temperature rise value of each portion met the standards. The dielectric properties after the temperature test also met the standard criteria.

Table 1

Item Standard Coil Model Name Nominal Value	Test Conditions						Results (Note a))						Judgment	
	Current [A]		Connection Wire Size [mm ²]		Voltage Applied to Coil [V]	Maximum Temperature Rise Value [K]			Dielectric Properties					
	Main Circuit	Auxiliary Circuit	Main Circuit	Auxiliary Circuit		Coil [Resistance Method]	Terminal		Contact		Impulse (Note c))	Power Frequency (Note c))		
					Main Circuit		Auxiliary Circuit	Main Circuit	Auxiliary Circuit					
	Open Thermoelectric Current											7.3kV 1.2/50 μs x5 times	1890V 5 seconds	
SD-T12 24VDC	20	10	2.5	1.5	24	29	52	34	77	52	OK	OK	OK	
SD-T12 100VDC	20	10	2.5	1.5	100	38	52	34	77	52	OK	OK	OK	
SD-T20 24VDC	20	10	2.5	1.5	24	29	43	34	65	52	OK	OK	OK	
SD-T20 100VDC	20	10	2.5	1.5	100	38	43	34	65	52	OK	OK	OK	
SD-T21 24VDC	32	10	6	1.5	24	27	35	27	45	46	OK	OK	OK	
SD-T21 100VDC	32	10	6	1.5	100	38	35	27	45	46	OK	OK	OK	
SD-T32 24VDC	32	-	6	-	24	36	31	-	40	-	OK	OK	OK	
SD-T32 100VDC	32	-	6	-	100	46	31	-	40	-	OK	OK	OK	
SD-T35 24VDC	60	10	16	1.5	24	67	35	30	46	45	OK	OK	OK	
SD-T50 24VDC	80	10	25	1.5	24	71	40	32	55	46	OK	OK	OK	
SD-T65 24VDC	100	10	35	1.5	24	63	39	28	58	43	OK	OK	OK	
SD-T80 24VDC	120	10	50	1.5	24	66	54	25	68	43	OK	OK	OK	
SD-T100 24VDC	150	10	50	1.5	24	62	57	46	92	59	OK	OK	OK	

Note a) The test of temperature rise value was conducted by operating at an ambient temperature of 40°C, in open state with the iron plate mounted.

Note b) The temperature rise value of the contacts was checked at a temperature that is not harmful to the surrounding components. (In short 100K)

Note c) The application points of the impulse withstand voltage performance and the power frequency withstand voltage performance were as follows. However in the power frequency withstand voltage test, (c) was not implemented.

Measurement Points: (a) Between all terminals of the main circuit and grounded metal body when the contact element was closed.

(b) Between one pole of the main circuit and all other poles connected altogether to the grounded metal body when the contact element was closed.

(c) Between the supply side terminals and the load side terminals of the main circuit when the contact element was opened.

(d) Between one circuit of the operating circuit (control circuit) and auxiliary circuit, and all other circuits/grounded metal body.

Note d) Number of Samples: 1 per machine

3.2.2 Verification of Operating Limits

The operating voltage (hot condition) and open-circuit voltage after the temperature test met the standard criteria by operating and opening without hindrance in the set voltage.

Table 2

Item Standard Coil Model Name Nominal Value	Test Conditions and Judgment			Judgment
	Operating Voltage (40°C Hot)		Open-circuit Voltage (-5°C Cold)	
	Operation at 85% or less of the coil rated voltage	Operation at 110% of the coil rated voltage	Open at 10 to 75% of the coil rated voltage	
SD-T12 24VDC	18.6	OK	4.9	OK
SD-T12 100VDC	72	OK	20	OK
SD-T20 24VDC	18.5	OK	5.2	OK
SD-T20 100VDC	71	OK	21	OK
SD-T21 24VDC	17.1	OK	4.5	OK
SD-T21 100VDC	64	OK	18	OK
SD-T32 24VDC	18.1	OK	4.3	OK
SD-T32 100VDC	70	OK	17	OK
SD-T35 24VDC	17.8	OK	5.7	OK
SD-T50 24VDC	18.2	OK	6.1	OK
SD-T65 24VDC	19.0	OK	5.8	OK
SD-T80 24VDC	20.1	OK	6.2	OK
SD-T100 24VDC	17.5	OK	5.5	OK

Note a) Coil rated voltage is 24V when coil nominal voltage is 24VDC, and is 100V when coil nominal voltage is 100VDC.

<Reference Test>

Coil characteristics (20°C cold condition)

Model Name	Coil Properties			Operating Voltage		Operating Time [ms]					
	Coil Current [A]	Consumption Power [W]	Coil Time Constant [ms]	Voltage		Coil ON →			Coil OFF →		
				Operation	Open	Main Contact ON	Auxiliary Contact a ON	Auxiliary Contact b OFF	Main Contact OFF	Auxiliary Contact a OFF	Auxiliary Contact b ON
SD-T12	0.033	3.3(2.2)	40(45)	60 to 75	10 to 30	55 to 75 (75 to 95)	55 to 75 (75 to 95)	50 to 70 (70 to 90)	5 to 15	5 to 15	10 to 20
SD-T20	0.033	3.3(2.2)	40(45)	60 to 75	10 to 30	55 to 75 (75 to 95)	55 to 75 (75 to 95)	50 to 70 (70 to 90)	5 to 15	5 to 15	10 to 20
SD-T21	0.033	3.3(2.2)	50(40)	60 to 75	10 to 30	60 to 80 (80 to 100)	60 to 80 (80 to 100)	55 to 75 (75 to 95)	5 to 15	5 to 15	10 to 20
SD-T32	0.033	3.3(2.2)	50(40)	60 to 75	10 to 30	65 to 85 (85 to 105)	-	-	5 to 15	-	-
SD-T35	0.09	9	40	50 to 65	15 to 35	45 to 55	45 to 55	38 to 48	6 to 10	6 to 10	9 to 13
SD-T50	0.09	9	40	50 to 65	15 to 35	45 to 55	45 to 55	38 to 48	6 to 10	6 to 10	9 to 13
SD-T65	0.18	18	65	52 to 63	20 to 35	45 to 55	45 to 55	40 to 50	9 to 16	9 to 16	12 to 19
SD-T80	0.18	18	65	52 to 63	20 to 35	45 to 55	45 to 55	40 to 50	9 to 16	9 to 16	12 to 19
SD-T100	0.24	24	80	50 to 65	15 to 30	70 to 80	70 to 80	63 to 73	14 to 21	14 to 21	18 to 25

Note a) The standard values of the properties of the 100VDC coil. The values in brackets () for SD-T12 to SD-T32 are property values of the 24VDC coil.

3.3 Test Sequence II

3.3.1 Test of Closed-circuit and Breaking Capacities

(1) Test of Closed-circuit Capacity

These tests were conducted according to the test conditions indicated in Table 3 and Note a) to c). No abnormalities such as welding of contacts were found, and the results met the standard criteria.

Table 3

Item Standard Model Name	Rated Value (AC-grade 3)		Test Conditions (closed circuit)						Results	Judgment
	Voltage U _e [V]	Current I _e [A]	Voltage U [V]	Current I [A]	Power Factor cosφ	Operating Cycle [Times] (Note b))	ON time [seconds]	OFF time [seconds]		
	-	-	1.05 x U _e	10 x I _e	0.45 ±0.05	50	0.05	10	Contact Welding	
SD-T12 24VDC	220	13	231	130	0.45	50	0.05	10	None	OK
	440	9	462	90	0.45	50	0.05	10	None	
SD-T20 24VDC	220	18	231	180	0.45	50	0.05	10	None	OK
	440	18	462	180	0.45	50	0.05	10	None	
SD-T21 24VDC	220	20	231	200	0.45	50	0.05	10	None	OK
	440	20	462	200	0.45	50	0.05	10	None	
SD-T32 24VDC	220	32	231	320	0.45	50	0.05	10	None	OK
	440	32	462	320	0.45	50	0.05	10	None	
SD-T35 24VDC	220	35	231	350	0.45	50	0.05	10	None	OK
	440	32	462	320	0.45	50	0.05	10	None	
SD-T50 24VDC	220	50	231	500	0.45	50	0.05	10	None	OK
	440	48	462	480	0.45	50	0.05	10	None	
SD-T65 24VDC	220	65	231	650	0.45	50	0.05	10	None	OK
	440	65	462	650	0.45	50	0.05	10	None	
SD-T80 24VDC	220	80	231	800	0.45	50	0.05	10	None	OK
	440	80	462	800	0.45	50	0.05	10	None	
SD-T100 24VDC	220	100	231	1000	0.45	50	0.05	10	None	OK
	440	93	462	930	0.45	50	0.05	10	None	

Note a) Main circuit frequency: 60Hz

Note b) Among 50 operating cycles, 110% of the rated value (26.4V) was applied to the coil for 25 cycles, and 85% of the rated value (20.4V) was applied to the coil for the other 25 cycles.

Note c) Number of Samples: 1 per machine

(2) Test of Closed-circuit and Breaking Capacities

These tests were conducted according to the test conditions indicated in Table 4 and Note a) to c) after the closed-circuit capacity test (1). No abnormalities such as welding of contacts and phase-to-phase short circuits were found, and the results met the standard criteria.

Table 4

Item Standard Model Name	Rated Value (AC-grade 3)		Test Conditions (closed circuit and breaking capacity)						Results	Judgment
	Voltage U _e [V]	Current I _e [A]	Voltage U [V]	Current I [A]	Power Factor cosφ	Operating Cycle [Times]	ON time [seconds]	OFF time [seconds]		
	-	-	1.05 x U _e	8 x I _e	0.45 ±0.05	50	0.05	I _c ≤ 100: 10 100 < I _c ≤ 200: 20 200 < I _c ≤ 300: 30 300 < I _c ≤ 400: 40 400 < I _c ≤ 600: 60 600 < I _c ≤ 800: 80	Contact Welding and Phase-to-phase Short-circuits	
SD-T12 24VDC	220	13	231	104	0.45	50	0.05	20	None	OK
	440	9	462	72	0.45	50	0.05	10	None	
SD-T20 24VDC	220	18	231	144	0.45	50	0.05	20	None	OK
	440	18	462	144	0.45	50	0.05	20	None	
SD-T21 24VDC	220	20	231	160	0.45	50	0.05	20	None	OK
	440	20	462	160	0.45	50	0.05	20	None	
SD-T32 24VDC	220	32	231	256	0.45	50	0.05	30	None	OK
	440	32	462	256	0.45	50	0.05	30	None	
SD-T35 24VDC	220	35	231	280	0.45	50	0.05	30	None	OK
	440	32	462	256	0.45	50	0.05	30	None	
SD-T50 24VDC	220	50	231	400	0.45	50	0.05	40	None	OK
	440	48	462	384	0.45	50	0.05	40	None	
SD-T65 24VDC	220	65	231	520	0.45	50	0.05	60	None	OK
	440	65	462	520	0.45	50	0.05	60	None	
SD-T80 24VDC	220	80	231	640	0.45	50	0.05	80	None	OK
	440	80	462	640	0.45	50	0.05	80	None	
SD-T100 24VDC	220	100	231	800	0.45	50	0.05	80	None	OK
	440	93	462	774	0.45	50	0.05	80	None	

Note a) Main circuit frequency: 60Hz

Note b) The operation was conducted by applying a voltage of 24V to the operating coil.

Note c) Number of Samples: 1 per machine

(3) Verification of the Switching Capacity and Reversibility

These tests were conducted according to the test conditions indicated in Table 5, 6 and Note a) to c). No abnormalities such as welding of contacts and phase-to-phase short circuits were found, and the results met the standard criteria.

Table 5

Item	Rated Value (AC-grade 4)		Test Conditions (closed circuit)						Results	Judgment
	Voltage Ue [V]	Current Ie [A]	Voltage Ur [V]	Current Ic [A]	Power Factor cosφ	Operation Cycle [Times]	ON time [seconds]	Down time [seconds]		
	Standard	-	-	1.05 x Ue	12 x Ie	0.45±0.05	50	0.05	10	
Model Name										
SD-2 x T12	220	11	231	132	0.45	50	0.05	10	None	OK
	440	9	462	108	0.45	50	0.05	10	None	OK
SD-2 x T20	220	18	231	216	0.45	50	0.05	10	None	OK
	440	13	462	156	0.45	50	0.05	10	None	OK
SD-2 x T21	220	18	231	216	0.45	50	0.05	10	None	OK
	440	13	462	156	0.45	50	0.05	10	None	OK
SD-2 x T32	220	26	231	312	0.45	50	0.05	10	None	OK
	440	24	462	288	0.45	50	0.05	10	None	OK
SD-2 x T35	220	26	231	312	0.45	50	0.05	10	None	OK
	440	24	462	288	0.45	50	0.05	10	None	OK
SD-2 x T50	220	35	231	420	0.45	50	0.05	10	None	OK
	440	32	462	384	0.45	50	0.05	10	None	OK
SD-2 x T65	220	50	231	600	0.45	50	0.05	10	None	OK
	440	47	462	564	0.45	50	0.05	10	None	OK
SD-2 x T80	220	65	231	780	0.45	50	0.05	10	None	OK
	440	62	462	744	0.45	50	0.05	10	None	OK
SD-2 x T100	220	80	231	960	0.45	50	0.05	10	None	OK
	440	75	462	900	0.45	50	0.05	10	None	OK

Table 6

Item	Rated Value (AC-grade 4)		Test Conditions (closed circuit and breaking capacity)							Results	Judgment
	Voltage Ue [V]	Current Ie [A]	Voltage Ur [V]	Current Ic [A]	Power Factor cosφ	Operation Cycle [Times]	ON time [seconds]	Down time [seconds]			
	Standard	-	-	1.05 x Ue	10 x Ie	0.45±0.05	50	10	0.05	Simultaneous Excitation Test	
Model Name											
SD-2 x T12	220	11	231	110	0.45	50	10	0.05	20	None	OK
	440	9	462	90	0.45	50	10	0.05	10	None	OK
SD-2 x T20	220	18	231	180	0.45	50	10	0.05	20	None	OK
	440	13	462	130	0.45	50	10	0.05	20	None	OK
SD-2 x T21	220	18	231	180	0.45	50	10	0.05	20	None	OK
	440	13	462	130	0.45	50	10	0.05	20	None	OK
SD-2 x T32	220	26	231	260	0.45	50	10	0.05	30	None	OK
	440	24	462	240	0.45	50	10	0.05	30	None	OK
SD-2 x T35	220	26	231	260	0.45	50	10	0.05	30	None	OK
	440	24	462	240	0.45	50	10	0.05	30	None	OK
SD-2 x T50	220	35	231	350	0.45	50	10	0.05	40	None	OK
	440	32	462	320	0.45	50	10	0.05	40	None	OK
SD-2 x T65	220	50	231	500	0.45	50	10	0.05	60	None	OK
	440	47	462	470	0.45	50	10	0.05	60	None	OK
SD-2 x T80	220	65	231	650	0.45	50	10	0.05	80	None	OK
	440	62	462	620	0.45	50	10	0.05	80	None	OK
SD-2 x T100	220	80	231	800	0.45	50	10	0.05	80	None	OK
	440	75	462	750	0.45	50	10	0.05	80	None	OK

Note a) Main circuit frequency: 60Hz

Note b) In the operating cycle, close circuit A - open circuit A - close circuit B - open circuit B - down time, makes 1 cycle. The switching from open circuit A to close circuit B was performed in the shortest time on the control system.

Note c) Number of Samples: 1 per machine

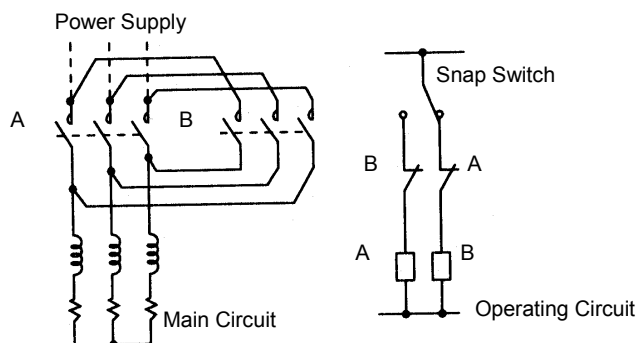

3.3.2 Verification of the Operating Performance

(1) Non-reversible

These tests were conducted according to the test conditions indicated in Table 7 and Note a) to c). No abnormalities such as welding of contacts and phase-to-phase short circuits were found, and the results met the standard criteria. After the test, the withstand voltage performance was checked by applying a voltage of 1000V and a frequency of 60Hz for 5 seconds, and the results were acceptable.

Table 7

Item Standard Model Name	Rated Value (AC-grade 3)		Test Conditions (closed circuit and breaking capacity)						Results		Judgment
	Voltage U _e [V]	Current I _e [A]	Voltage U [V]	Current I _c [A]	Power Factor cosφ	Operating Cycle [Times]	ON time [seconds]	OFF time [seconds]	Closed Circuit and Breaking capacity	Withstand Voltage	
	-	-	1.05 x U _e	2 x I _e	0.45 ±0.05	6000	0.05	I _c ≤ 100: 10 100 < I _c ≤ 200: 20	Contact Welding and Phase-to-phase Short-circuits	2 x U _e provided 1000V or higher 5 seconds	
SD-T12 24VDC	220	13	231	26	0.45	6000	0.05	10	None	OK	OK
	440	9	462	18	0.45	6000	0.05	10	None	OK	OK
SD-T20 24VDC	220	18	231	36	0.45	6000	0.05	10	None	OK	OK
	440	18	462	36	0.45	6000	0.05	10	None	OK	OK
SD-T21 24VDC	220	20	231	40	0.45	6000	0.05	10	None	OK	OK
	440	20	462	40	0.45	6000	0.05	10	None	OK	OK
SD-T32 24VDC	220	32	231	64	0.45	6000	0.05	10	None	OK	OK
	440	32	462	64	0.45	6000	0.05	10	None	OK	OK
SD-T35 24VDC	220	35	231	70	0.45	6000	0.05	10	None	OK	OK
	440	32	462	64	0.45	6000	0.05	10	None	OK	OK
SD-T50 24VDC	220	50	231	100	0.45	6000	0.05	10	None	OK	OK
	440	48	462	96	0.45	6000	0.05	10	None	OK	OK
SD-T65 24VDC	220	65	231	130	0.45	6000	0.05	20	None	OK	OK
	440	65	462	130	0.45	6000	0.05	20	None	OK	OK
SD-T80 24VDC	220	80	231	160	0.45	6000	0.05	20	None	OK	OK
	440	80	462	160	0.45	6000	0.05	20	None	OK	OK
SD-T100 24VDC	220	100	231	200	0.45	6000	0.05	20	None	OK	OK
	440	93	462	186	0.45	6000	0.05	20	None	OK	OK

Note a) Main circuit frequency: 60Hz

Note b) The operation was conducted by applying 24VDC to the operating coil.

Note c) Number of Samples: 1 per machine

(2) Reversible

These tests were conducted according to the test conditions indicated in Table 8 and Note a) to d). No abnormalities such as welding of contacts and phase-to-phase short circuits were found, and the results met the standard criteria. After the test, the withstand voltage performance was checked by applying a voltage of 1000V and a frequency of 60Hz for 5 seconds, and the results were acceptable.

Table 8

Item Standard Model Name	Rated Value (AC-grade 4)		Test Conditions (closed circuit and breaking capacity)						Results		Judgment
	Voltage U _e [V]	Current I _e [A]	Voltage U _r [V]	Current I _c [A]	Power Factor cosφ	Operation Cycle [Times] (Note c)	ON time [seconds]	OFF time [seconds]	Closed Circuit and Breaking capacity	Withstand Voltage	
	-	-	1.05 x U _e	6 x I _e	0.45±0.05	6000	0.05	I _c ≤ 100: 10 100 < I _c ≤ 200: 20 200 < I _c ≤ 300: 30 300 < I _c ≤ 400: 40 400 < I _c ≤ 600: 60	Contact Welding and Phase-to-phase Short-circuits	2 x U _e provided 1000V or higher 5 seconds	
SD-2 x T12	220	11	231	66	0.45	6000	0.05	10	None	OK	OK
	440	9	462	54	0.45	6000	0.05	10	None	OK	OK
SD-2 x T20	220	18	231	108	0.45	6000	0.05	20	None	OK	OK
	440	13	462	78	0.45	6000	0.05	10	None	OK	OK
SD-2 x T21	220	18	231	108	0.45	6000	0.05	20	None	OK	OK
	440	13	462	78	0.45	6000	0.05	10	None	OK	OK
SD-2 x T32	220	26	231	156	0.45	6000	0.05	20	None	OK	OK
	440	24	462	144	0.45	6000	0.05	20	None	OK	OK
SD-2 x T35	220	26	231	156	0.45	6000	0.05	20	None	OK	OK
	440	24	462	144	0.45	6000	0.05	20	None	OK	OK
SD-2 x T50	220	35	231	210	0.45	6000	0.05	30	None	OK	OK
	440	32	462	192	0.45	6000	0.05	20	None	OK	OK
SD-2 x T65	220	50	231	300	0.45	6000	0.05	30	None	OK	OK
	440	47	462	282	0.45	6000	0.05	30	None	OK	OK
SD-2 x T80	220	65	231	390	0.45	6000	0.05	40	None	OK	OK
	440	62	462	372	0.45	6000	0.05	40	None	OK	OK
SD-2 x T100	220	80	231	480	0.45	6000	0.05	60	None	OK	OK
	440	75	462	450	0.45	6000	0.05	60	None	OK	OK

Note a) Main circuit frequency: 60Hz

Note b) The operation was conducted by applying 24VDC to the operating coil.

Note c) The operation was performed based on the cycle mentioned in Note b) of 3.3.1 (3).

Note d) Number of Samples: 1 per machine

3.4 Test Sequence III

3.4.1 Performance under Short-circuit Conditions

These tests were conducted according to the test conditions indicated in Table 9 and Note a) to d). There was no damage to the conductors and terminals. The leakage detection fuse was not melted, and the results were acceptable.

Table 9

Item Standard	Rated Current of SCPD [A] (Note a))	Rated Value (AC-grade 3)		Test Conditions			Results			Judgment
		Voltage Ue [V]	Current Ie [A]	Voltage [V]	Current I [kA]	Power Factor cosφ	O or CO Operation	Conductor/ Terminal Damage	Melting of the Leakage Detection Fuse	
Model Name	-	-	-	Ue	(Note b))	(Note c))	(Note d))	None	None	
SD-T12	40	220/440	13/9	440	1	0.95	O CO	None None	None None	OK
SD-T20	40	220/440	18/18	440	3	0.9	O CO	None None	None None	OK
SD-T21	80	220/440	20/20	440	3	0.9	O CO	None None	None None	OK
SD-T32	80	220/440	32/32	440	3	0.9	O CO	None None	None None	OK
SD-T35	100	220/440	35/32	440	3	0.9	O CO	None None	None None	OK
SD-T50	100	220/440	50/48	440	3	0.9	O CO	None None	None None	OK
SD-T65	100	220/440	65/65	440	5	0.7	O CO	None None	None None	OK
SD-T80	125	220/440	80/80	440	5	0.7	O CO	None None	None None	OK
SD-T100	160	220/440	100/93	440	5	0.7	O CO	None None	None None	OK

Note a) SCPD: Short Circuit Protection Device

Note b) The test currents of specified standards for rated operating current were as follows. (Ie indicates the maximum current to be applied to the motor.)

In the case of $1 < I_e \leq 16$: 1 kA In the case of $16 < I_e \leq 63$: 3 kA In the case of $63 < I_e \leq 125$: 5 kA

Note c) The power factors of specified standards for test current are as follows.

In the case of $I \leq 1.5$ kA: 0.95 ± 0.05 In the case of 1.5 kA $< I \leq 3$ kA: 0.9 ± 0.05 In the case of 4.5 kA $< I \leq 6$ kA: 0.7 ± 0.05

Note d) O operation: Breaking of the circuit by the SCPD resulting from closing the circuit on the equipment under test which is in the closed position.

CO operation: Breaking of the circuit by the SCPD resulting from closing the circuit by the equipment under test.

3.5 Test Sequence IV

3.5.1 Verification of Ability of Contactors to Withstand Overload Currents

The current indicated in Table 10 was applied for 10 seconds in closed circuit conditions of the contactor. All the parts met the standard criteria without abnormality.

Table 10

Item Standard	200 to 220V Rated Current [A] Ie (AC-3)	Test Conditions		Results	Judgment
		Current [A]	Current Passage Time [seconds]		
Model Name		Ie x 8	10	Abnormality in the part	
SD-T12	13	104	10	None	OK
SD-T20	18	144	10	None	OK
SD-T21	20	160	10	None	OK
SD-T32	32	256	10	None	OK
SD-T35	35	280	10	None	OK
SD-T50	50	400	10	None	OK
SD-T65	65	520	10	None	OK
SD-T80	80	640	10	None	OK
SD-T100	100	800	10	None	OK

Note a) Number of Samples: 1 per machine

3.6 Test Sequence V

3.6.1 Verification of Mechanical Properties of Terminals

(1) Tests of Mechanical Strength of Terminals

The crimp terminals described in Table 11 were tightened using the following tightening torques and tested by connection and disconnection 5 times. All the parts met the standard criteria without looseness or damage.

Table 11

Item Standard Model Name	Target Terminal Position	Crimp Terminal Size	Manufacturer Standard Tightening Torque [N·m]	Tested Tightening Torque [N·m]	Results	Judgment
	-	Conductor of the Maximum Cross-Sectional Area	-	110% of the Manufacturer Standard Tightening Torque	Looseness or Damage to the Part	
SD-T12	2/T1, 6/T3	2-3.5	0.9 to 1.5	1.65	None	OK
SD-T20	2/T1, 6/T3	2-3.5	0.9 to 1.5	1.65	None	OK
SD-T21	2/T1, 6/T3	5.5-4	1.2 to 1.9	2.09	None	OK
SD-T32	2/T1, 6/T3	5.5-4	1.2 to 1.9	2.09	None	OK
SD-T35	2/T1, 6/T3	22-S5	2.0 to 3.3	3.63	None	OK
SD-T50	2/T1, 6/T3	22-S5	2.0 to 3.3	3.63	None	OK
SD-T65	2/T1, 6/T3	60-S6	3.5 to 5.7	6.27	None	OK
SD-T80	2/T1, 6/T3	60-S6	3.5 to 5.7	6.27	None	OK
SD-T100	2/T1, 6/T3	60-6	3.5 to 5.7	6.27	None	OK

Note a) The test was conducted by applying 110% of the maximum value of the manufacturer standard tightening torque

Note b) Number of Samples: 1 per machine

(2) Flexion and Pull-out Tests

In the flexion tests, the wire was rotated 135 times continuously by placing weight on its pointed end under the conditions (the following tightening torques were checked by using the minimum value of the manufacturer standard tightening torque) indicated in Tables 12. The results met the standard criteria without pullout or breaking of the conductor. Then, the pull-out strength indicated in Tables 12 was applied for 1 minute. The results met the standard criteria without pullout or breaking of the conductor.

Table 12

Item	Target Terminal Position	Screw Size	Wire Specifications		Number of Connections	Manufacturer Standard Tightening Torque [N·m]	Tested Tightening Torque [N·m]	Diameter of the Bushing Hole [mm]	Height [mm]	Weight [kg]	Pulling Force [N]	Judgment
			Type	Size								
Standard	-	-	-	-	Maximum Number of Connections	-	Specified Tightening Torque	0.75mm ² : 6.5 1.25mm ² : 6.5 2.5mm ² : 9.5 4mm ² : 9.5 6mm ² : 9.5 14mm ² : 13.0 16mm ² : 13.0 φ1.6: 9.5 φ2: 9.5 φ2.6: 9.5 φ3.6: 13.0	0.75mm ² : 260 1.25mm ² : 260 2.5mm ² : 280 4mm ² : 280 6mm ² : 280 14mm ² : 300 16mm ² : 300 φ1.6: 280 φ2: 280 φ2.6: 280 φ3.6: 300	0.75mm ² : 0.4 1.25mm ² : 0.4 2.5mm ² : 0.7 4mm ² : 0.9 6mm ² : 1.4 14mm ² : 2.9 16mm ² : 2.9 φ1.6: 0.7 φ2: 0.9 φ2.6: 1.4 φ3.6: 2.9	0.75mm ² : 30 1.25mm ² : 40 2.5mm ² : 50 4mm ² : 60 6mm ² : 80 14mm ² : 100 16mm ² : 100 φ1.6: 50 φ2: 60 φ2.6: 80 φ3.6: 100	Pullout or Breaking of Conductor
Model Name												
SD-T12	2/T1	M3.5	Stranded Wire	0.75mm ²	2	0.9 to 1.5	0.9	6.5	260	0.4	30	OK
				2.5mm ²	2	0.9 to 1.5	0.9	9.5	280	0.7	50	OK
			Single Wire	φ1.6	2	0.9 to 1.5	0.9	9.5	280	0.7	50	OK
	6/T3	M3.5	Stranded Wire	0.75mm ²	2	0.9 to 1.5	0.9	6.5	260	0.4	30	OK
				2.5mm ²	2	0.9 to 1.5	0.9	9.5	280	0.7	50	OK
			Single Wire	φ1.6	2	0.9 to 1.5	0.9	9.5	280	0.7	50	OK
SD-T20	2/T1	M3.5	Stranded Wire	0.75mm ²	2	0.9 to 1.5	0.9	6.5	260	0.4	30	OK
				2.5mm ²	2	0.9 to 1.5	0.9	9.5	280	0.7	50	OK
			Single Wire	φ1.6	2	0.9 to 1.5	0.9	9.5	280	0.7	50	OK
	6/T3	M3.5	Stranded Wire	0.75mm ²	2	0.9 to 1.5	0.9	6.5	260	0.4	30	OK
				2.5mm ²	2	0.9 to 1.5	0.9	9.5	280	0.7	50	OK
			Single Wire	φ1.6	2	0.9 to 1.5	0.9	9.5	280	0.7	50	OK
SD-T21	2/T1	M4	Stranded Wire	1.25mm ²	2	1.2 to 1.9	1.2	6.5	260	0.4	40	OK
				6mm ²	2	1.2 to 1.9	1.2	9.5	280	1.4	80	OK
			Single Wire	φ1.6	2	1.2 to 1.9	1.2	9.5	280	0.7	50	OK
				φ2.6	2	1.2 to 1.9	1.2	9.5	280	1.4	80	OK
	6/T3	M4	Stranded Wire	1.25mm ²	2	1.2 to 1.9	1.2	6.5	260	0.4	40	OK
				6mm ²	2	1.2 to 1.9	1.2	9.5	280	1.4	80	OK
Single Wire	φ1.6	2	1.2 to 1.9	1.2	9.5	280	0.7	50	OK			
										φ2.6	2	1.2 to 1.9
SD-T32	2/T1	M4	Stranded Wire	1.25mm ²	2	1.2 to 1.9	1.2	6.5	260			
				6mm ²	2	1.2 to 1.9	1.2	9.5	280	1.4	80	OK
			Single Wire	φ1.6	2	1.2 to 1.9	1.2	9.5	280	0.7	50	OK
				φ2.6	2	1.2 to 1.9	1.2	9.5	280	1.4	80	OK
	6/T3	M4	Stranded Wire	1.25mm ²	2	1.2 to 1.9	1.2	6.5	260	0.4	40	OK
				6mm ²	2	1.2 to 1.9	1.2	9.5	280	1.4	80	OK
Single Wire			φ1.6	2	1.2 to 1.9	1.2	9.5	280	0.7	50	OK	
			φ2.6	2	1.2 to 1.9	1.2	9.5	280	1.4	80	OK	
SD-T35	2/T1	M5	Stranded Wire	1.25mm ²	2	2.0 to 3.3	2.0	6.5	260	0.4	40	OK
				16mm ²	2	2.0 to 3.3	2.0	13.0	300	2.9	100	OK
			Single Wire	φ1.6	2	2.0 to 3.3	2.0	9.5	280	0.7	50	OK
				φ3.6	2	2.0 to 3.3	2.0	13.0	300	2.9	100	OK
	6/T3	M5	Stranded Wire	1.25mm ²	2	2.0 to 3.3	2.0	6.5	260	0.4	40	OK
				16mm ²	2	2.0 to 3.3	2.0	13.0	300	2.9	100	OK
Single Wire	φ1.6	2	2.0 to 3.3	2.0	9.5	280	0.7	50	OK			
										φ3.6	2	2.0 to 3.3
SD-T50	2/T1	M5	Stranded Wire	1.25mm ²	2	2.0 to 3.3	2.0	6.5	260			
				16mm ²	2	2.0 to 3.3	2.0	13.0	300	2.9	100	OK
			Single Wire	φ1.6	2	2.0 to 3.3	2.0	9.5	280	0.7	50	OK
				φ3.6	2	2.0 to 3.3	2.0	13.0	300	2.9	100	OK
	6/T3	M5	Stranded Wire	1.25mm ²	2	2.0 to 3.3	2.0	6.5	260	0.4	40	OK
				16mm ²	2	2.0 to 3.3	2.0	13.0	300	2.9	100	OK
Single Wire	φ1.6	2	2.0 to 3.3	2.0	9.5	280	0.7	50	OK			
										φ3.6	2	2.0 to 3.3

Note a) Since SD-T65 or higher models cannot be connected to the unprocessed exposed conductor, this evaluation is not applicable.

■ Mechanical Latch Type Magnetic Contactor

<SL-T, SLD-T Type>

The SL-T, SLD-T type mechanical latch type magnetic contactors are the S-T type magnetic contactors with mechanical latch feature. This instant excitation type magnetic contactor is composed of a closing coil and tripping coil. At the time of closing, the closing coil is energized and the ON state is mechanically held. At the time of opening, the tripping coil is energized to remove the joining element of the latch.

1. Usage

- Can be used as a memory circuit in which the contactor maintains the closed-circuit state at the time of power failure, instantaneous power failure or voltage drop.
- The switchboard can be used as a circuit in facilities sensitive to noise (hospitals, buildings etc.).
- The circuit can be used for long time power supply such as road lighting.
- The switching frequency is done less often resulting in saving the continuous power consumption of coil.

2. Rating

Model Name	Rated operating current of AC-grade 3 [A]			Open Thermoelectric Current I _{th} [A]	Auxiliary Contact		Switching Frequency	Life	
	200 to 220V	380 to 440V	500 to 550V		Valid	For Self-Demagnetization		Mechanical	Electrical
SL-T21 SLD-T21	20	20	17	32	2a2b	1a1b	1200 times/hour	500000 Times	500000 Times

3. Type Test

Applicable Standard JIS C8201-1 (2007) Low voltage switchgear and control gear Part 1: General Rule
 JIS C8201-4-1 (2010) Low voltage switchgear and control gear Part 4: Contactor and Motor Starter Section 1: Electro-mechanical Contactor and Motor Starter

3.1 Type Tests and Test Sequences

Test Sequences	Test Name	Test Conditions
a) Sequence I	1) Verification of temperature rise	According to the JIS C8201-4-1 9.3.3.3 "Temperature Rise".
	2) Verification of operation and operating limits	According to the JIS C8201-4-1 9.3.3.1 "Operation" and 9.3.3.2 "Operating limit".
	3) Verification of dielectric properties	According to the JIS C8201-4-1 9.3.3.4 "Dielectric Properties".
b) Sequence II	1) Verification of rated close-circuit and breaking capacity	According to the JIS C8201-4-1 9.3.3.5 "Closed-circuit and Breaking Capacity".
	2) Verification of conventional operating performance	According to the JIS C8201-4-1 9.3.3.6 "Operating Performance Capability".
c) Sequence III	1) Performance under short-circuit conditions	According to the JIS C8201-4-1 9.3.4 "Performance under Short-circuit Conditions".
d) Sequence IV	1) Verification of ability of contactors to withstand overload currents	According to the JIS C8201-4-1 9.3.5 "Ability of Contactors to Withstand Overload Currents".
e) Sequence V	1) Verification of mechanical properties of terminals	According to the JIS C8201-1 8.2.4 "Mechanical Properties of Terminals".

Note a) As only the operating coils differ in the SL-T type and SLD-T type (AC operation coil for SL-T type and DC operation coil for SLD-T type), the items that do not affect the operation were carried out with SL-T type.

Note b) For SL-T type, the coil with nominal voltage 200VAC (200-240V, 50Hz/60Hz) was used. For SLD-T type, the coil with nominal voltage 100VDC (Rated voltage 100-110V) was used.

3.2 Test Sequence I

3.2.1 Verification of Temperature Rise and Dielectric Properties

These tests were conducted according to the test conditions indicated in Table 1 and Note a) to f), the temperature rise of each part met the standard criteria of temperature rise limit. Also the operations, dielectric properties, and insulation resistances after the temperature tests met the standard criteria.

Table 1

Item Standard Model Name	Test Conditions			Results (Note a))						Judgment
	Current [A]		Connection Wire Size [mm ²] (Note b))	Maximum Temperature Rise Value [K]				Dielectric Properties		
	Main Circuit	Auxiliary Circuit		Terminal		Contact		Impulse (Note e))	Power Frequency (Note e))	
			Main Circuit	Auxiliary Circuit	Main Circuit	Auxiliary Circuit				
	Open Thermoelectric Current		-	65 or less	65 or less	(Note d))		7.3kV 1.2/50 μs x5 times	1890V 5 seconds	
SL-T21	32	10	6	27	30	36	36	OK	OK	OK

- Note a) The test of temperature rise value was conducted by operating at an ambient temperature of 40°C, in open state with the iron plate mounted.
- Note b) The connection wire size of the auxiliary circuit: 1.5 mm²
- Note c) The operating coils were not measured because they are instant excitation type.
- Note d) The temperature rise value of the contacts was checked at a temperature that is not harmful to the surrounding components. (In short 100K)
- Note e) The application points of the impulse withstand voltage performance and the power frequency withstand voltage performance were as follows. However in the power frequency withstand voltage test, (c) was not implemented.
Measurement Points: (a) Between all terminals of the main circuit and grounded metal body when the contact element was closed.
(b) Between one pole of the main circuit and all other poles connected altogether to the grounded metal body when the contact element was closed.
(c) Between the supply side terminals and the load side terminals of the main circuit when the contact element was opened.
(d) Between one circuit of the operating circuit and auxiliary circuit, and all other circuits/grounded metal body.

Note f) Number of Samples: 1 per machine

3.2.2 Verification of Operating Limits

The input voltage and trip voltage after the temperature test met the standard criteria by operating without hindrance in the set voltage.

Table 2

Item Standard Model Name	Test Conditions and Judgment				Judgment
	Input Voltage (40°C Cold)		Trip Voltage (-5°C Cold)		
	Operation at 85% or less of the Coil Rated Voltage (Note a))	Operation at 110% of the Coil Rated Voltage (Note b))	Operation at 85% or less of the Coil Rated Voltage (Note a))		
SL-T21	50Hz	131	OK	90	OK
	60Hz	157	OK	105	OK
SLD-T21	-	68.5	OK	52	OK

Note a) The operation at 85% or less of the coil rated voltage of standard value was possible at 170V 50Hz/60Hz for SL-T21. The operation was also possible at 85VDC for SLD-T21.

Note b) The operation at 110% of the coil rated voltage of standard value was possible at 264V 50Hz/60Hz for SL-T21. The operation was also possible at 121VDC for SLD-T21.

3.3 Test Sequence II

3.3.1 Test of Closed-circuit and Breaking Capacities

(1) Test of Closed-circuit Capacity

These tests were conducted according to the test conditions indicated in Table 3 and Note a) to c). No abnormalities such as welding of contacts were found, and the results met the standard criteria.

Table 3

Item Standard Model Name	Rated Value (AC-grade 3)		Test Conditions (closed circuit)						Results	Judgment
	Voltage U _e [V]	Current I _e [A]	Voltage U [V]	Current I [A]	Power Factor cosφ	Operating Cycle [Times] (Note b))	ON time [seconds]	OFF time [seconds]		
SL-T21	220	20	231	200	0.45	50	0.05	10	None	OK
	440	20	462	200	0.45	50	0.05	10	None	OK

Note a) Main circuit frequency: 60Hz

Note b) Among 50 operating cycles, 110% of the rated value (264V 60Hz) was applied to the coil for 25 cycles, and 85% of the rated value (170V 60Hz) was applied to the coil for the other 25 cycles.

Note c) Number of Samples: 1 per machine

(2) Test of Closed-circuit and Breaking Capacities

These tests were conducted according to the test conditions indicated in Table 4 and Note a) to c). No abnormalities such as welding of contacts and phase-to-phase short circuits were found, and the results met the standard criteria.

Table 4

Item	Rated Value (AC-grade 3)		Test Conditions (closed circuit and breaking capacity)						Results	Judgment
	Voltage U _e [V]	Current I _e [A]	Voltage U [V]	Current I [A]	Power Factor cosφ	Operating Cycle [Times]	ON time [seconds]	OFF time [seconds]		
Standard	-	-	1.05 x U _e	8 x I _e	I _e ≤ 100A: 0.45 ± 0.05 I _e > 100A: 0.35 ± 0.05	50	0.05	I _c ≤ 100: 10 100 < I _c ≤ 200: 20	Contact Welding and Phase-to-phase Short-circuits	
Model Name										
SL-T21	220	20	231	160	0.45	50	0.05	20	None	OK
	440	20	462	160	0.45	50	0.05	20	None	OK

Note a) Main circuit frequency: 60Hz

Note b) The operation was conducted by applying a voltage of 240V and a frequency of 60Hz to the operating coil.

Note c) Number of Samples: 1 per machine

(3) Verification of the Switching Capacity and Reversibility

These tests were conducted according to the test conditions indicated in Table 5, 6 and Note a) to c). No abnormalities such as welding of contacts and phase-to-phase short circuits were found, and the results met the standard criteria.

Table 5

Item	Rated Value (AC-grade 4)		Test Conditions (closed circuit)						Results	Judgment
	Voltage U _e [V]	Current I _e [A]	Voltage U _r [V]	Current I _c [A]	Power Factor cosφ	Operation Cycle [Times]	ON time [seconds]	Down time [seconds]		
Standard	-	-	1.05 x U _e	12 x I _e	I _e ≤ 100A: 0.45 ± 0.05 I _e > 100A: 0.35 ± 0.05	50	0.05	10	Contact Welding and Phase-to-phase Short-circuits	
Model Name										
SL-2 x T21	220	18	231	216	0.45	50	0.05	10	None	OK
	440	13	462	156	0.45	50	0.05	10	None	OK

Table 6

Item	Rated Value (AC-grade 4)		Test Conditions (closed circuit and breaking capacity)							Results	Judgment
	Voltage U _e [V]	Current I _e [A]	Voltage U _r [V]	Current I _c [A]	Power Factor cosφ	Operation Cycle [Times]	Simultaneous Excitation Test	ON time [seconds]	Down time [seconds]		
Standard	-	-	1.05 x U _e	10 x I _e	I _e ≤ 100A: 0.45 ± 0.05 I _e > 100A: 0.35 ± 0.05	50	10	0.05	I _c ≤ 100: 10 100 < I _c ≤ 200: 20	Contact Welding and Phase-to-phase Short-circuits	
Model Name											
SL-2 x T21	220	18	231	180	0.45	50	10	0.05	20	None	OK
	440	13	462	130	0.45	50	10	0.05	20	None	OK

Note a) Main circuit frequency: 60Hz

Note b) In the operating cycle, close circuit A - open circuit A - close circuit B - open circuit B - down time, makes 1 cycle.

The switching from open circuit A to close circuit B was performed in the shortest time on the control system.

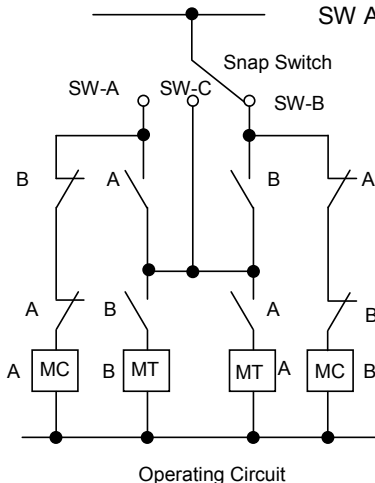
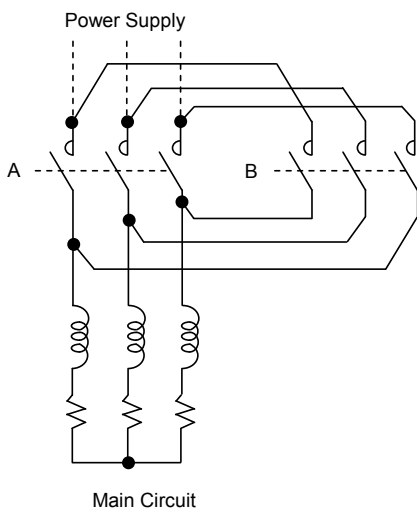

The snap switches were switched in the sequence of SW A → SW B → SW C → SW B → SW A → SW C →

Note c) Number of Samples: 1 per machine

3.3.2 Verification of the Operating Performance

(1) Non-reversible

These tests were conducted according to the test conditions indicated in Table 7 and Note a) to c). No abnormalities such as welding of contacts and phase-to-phase short circuits were found, and the results met the standard criteria. After the test, the withstand voltage performance was checked by applying a voltage of 1000V and a frequency of 60Hz for 5 seconds, and the results were acceptable.

Table 7

Item	Rated Value (AC-grade 3)		Test Conditions (closed circuit and breaking capacity)						Results		Judgment
	Voltage U _e [V]	Current I _e [A]	Voltage U [V]	Current I [A]	Power Factor cosφ	Operating Cycle [Times]	ON time [seconds]	OFF time [seconds]	Closed Circuit and Breaking capacity	Withstand Voltage	
Standard	-	-	1.05 x U _e	2 x I _e	I _e ≤ 100A: 0.45 ± 0.05 I _e > 100A: 0.35 ± 0.05	6000	0.05	I _c ≤ 100: 10	Contact Welding and Phase-to-phase Short-circuits	2 x U _e provided 1000V or higher 5 seconds	
Model Name											
SL-T21	220	20	231	40	0.45	6000	0.05	10	None	OK	OK
	440	20	462	40	0.45	6000	0.05	10	None	OK	OK

Note a) Main circuit frequency: 60Hz

Note b) The operation was conducted by applying a voltage of 240V and a frequency 60Hz to the operating coil.

Note c) Number of Samples: 1 per machine

(2) Reversible

These tests were conducted according to the test conditions indicated in Table 8 and Note a) to d). No abnormalities such as welding of contacts and phase-to-phase short circuits were found, and the results met the standard criteria. After the test, the withstand voltage performance was checked by applying a voltage of 1000V and a frequency of 60Hz for 5 seconds, and the results were acceptable.

Table 8

Item	Rated Value (AC-grade 4)		Test Conditions (closed circuit and breaking capacity)						Results		Judgment
	Voltage U _e [V]	Current I _e [A]	Voltage U _r [V]	Current I _c [A]	Power Factor cosφ	Operating Cycle [Times] (Note c)	ON time [seconds]	OFF time [seconds]	Closed Circuit and Breaking capacity	Withstand Voltage	
Standard	-	-	1.05 x U _e	6 x I _e	I _e ≤ 100A: 0.45 ± 0.05 I _e > 100A: 0.35 ± 0.05	6000	0.05	I _c ≤ 100: 10 100 < I _c ≤ 200: 20	Contact Welding and Phase-to-phase Short-circuits	2 x U _e provided 1000V or higher 5 seconds	
Model Name											
SL-2 x T21	220	18	231	108	0.45	6000	0.05	20	None	OK	OK
	440	13	462	78	0.45	6000	0.05	10	None	OK	OK

Note a) Main circuit frequency: 60Hz

Note b) The operation was conducted by applying a voltage of 240V and a frequency 60Hz to the operating coil.

Note c) The operation was performed based on the cycle mentioned in Note b) of 3.3.1 (3).

Note d) Number of Samples: 1 per machine

3.4 Test Sequence III

3.4.1 Performance under Short-circuit Conditions

These tests were conducted according to the test conditions indicated in Table 9 and Note a) to d). There was no damage to the conductors and terminals. The leakage detection fuse was not melted, and the results met the standard criteria.

Table 9

Item	Rated Current of SCPD [A] (Note a)	Rated Value (AC-grade 3)		Test Conditions			Results			Judgment
		Voltage U _e [V]	Current I _e [A]	Voltage [V]	Current I [kA]	Power Factor cosφ	O or CO Operation	Conductor/ Terminal Damage	Melting of the Leakage Detection Fuse	
Standard	-	-	-	U _e	-	(Note b)	(Note c)	None	None	
Model Name										
SL-T21	80	220/440	20/20	440	3	0.9	O	None	None	OK
							CO	None	None	

Note a) SCPD: Short Circuit Protection Device

Note b) The test currents of specified standards for rated operating current were as follows. (I_e indicates the maximum current to be applied to the motor.)

In the case of 16 < I_e ≤ 63: 3 kA

Note c) The power factors of specified standards for test current were as follows.

In the case of 1.5 kA < I ≤ 3 kA: 0.9 ± 0.05

Note d) O operation: Breaking of the circuit by the SCPD resulting from closing the circuit on the equipment under test which is in the closed position.

CO operation: Breaking of the circuit by the SCPD resulting from closing the circuit by the equipment under test.

3.5 Test Sequence IV

3.5.1 Verification of Ability of Contactors to Withstand Overload Currents

The current indicated in Table 10 was applied for 10 seconds in closed circuit conditions of the contactor. All the parts met the standard criteria without abnormality.

Table 10

Item	200 to 220V Rated Current [A]	Test Conditions		Results	Judgment
		Current [A]	Current Passage Time [seconds]		
Standard	Rated Operating Current I _e (AC-3)	I _e ≤ 630A: 8 x I _e I _e > 630A: 6 x I _e	10	Abnormality in the part	
Model Name	20	160	10	None	OK

Note a) Number of Samples: 1 per machine

3.6 Test Sequence V

3.6.1 Verification of Mechanical Properties of Terminals

(1) Tests of Mechanical Strength of Terminals

The crimp terminals described in Table 11 were tightened using the following tightening torques and tested by connection and disconnection 5 times. All the parts met the standard criteria without looseness or damage.

Table 11

Item	Target Terminal Position	Crimp Terminal Size	Manufacturer Standard Tightening Torque [N·m]	Tested Tightening Torque [N·m]	Results	Judgment
Standard	-	Conductor of the Maximum Cross-Sectional Area	-	110% of the Manufacturer Standard Tightening Torque	Looseness or Damage to the Part	
Model Name	2/T1, 6/T3	5.5-4	1.2 to 1.9	2.09 (110% of the maximum value)	None	OK

(2) Flexion and Pull-out Tests

In the flexion tests, the wire was rotated 135 times continuously by placing weight on its pointed end under the conditions (the following tightening torques were checked by using the minimum value of the manufacturer standard tightening torque) indicated in Tables 12. The results met the standard criteria without pullout or breaking of the conductor. Then, the pull-out strength indicated in Tables 12 was applied for 1 minute. The results met the standard criteria without pullout or breaking of the conductor.

Table 12

Item	Target Terminal Position	Screw Size	Wire Specifications		Number of Connections	Manufacturer Standard Tightening Torque [N·m]	Tested Tightening Torque [N·m]	Diameter of the Bushing Hole [mm]	Height [mm]	Weight [kg]	Pulling Force [N]	Judgment
			Type	Size								
Standard	-	-	-	-	Maximum Number of Connections	-	Specified Tightening Torque	1.25mm ² : 6.5 6mm ² : 9.5 φ1.6: 9.5 φ2.6: 9.5	1.25mm ² : 260 6mm ² : 280 φ1.6: 280 φ2.6: 280	1.25mm ² : 0.4 6mm ² : 1.4 φ1.6: 0.7 φ2.6: 1.4	1.25mm ² : 40 6mm ² : 80 φ1.6: 50 φ2.6: 80	Pullout or Breaking of Conductor
Model Name	2/T1	M4	Stranded Wire	1.25mm ²	2	1.2 to 1.9	1.2	6.5	260	0.4	40	OK
				6mm ²	2	1.2 to 1.9	1.2	9.5	280	1.4	80	OK
			Single Wire	φ1.6	2	1.2 to 1.9	1.2	9.5	280	0.7	50	OK
				φ2.6	2	1.2 to 1.9	1.2	9.5	280	1.4	80	OK
	6/T3	M4	Stranded Wire	1.25mm ²	2	1.2 to 1.9	1.2	6.5	260	0.4	40	OK
				6mm ²	2	1.2 to 1.9	1.2	9.5	280	1.4	80	OK
			Single Wire	φ1.6	2	1.2 to 1.9	1.2	9.5	280	0.7	50	OK
				φ2.6	2	1.2 to 1.9	1.2	9.5	280	1.4	80	OK

A large rectangular area containing numerous horizontal dashed lines, intended for writing a memo.

Environmental Characteristics and Special Performance

1. Surrounding Environment of the Magnetic Starter

There are various environmental conditions that can affect the use of a magnetic starter. It is necessary to clarify these conditions because they greatly affect the performance of the magnetic starter.

Generally, performance validation tests performed by the manufacturer are under the standard usage condition. Therefore, performance is guaranteed in the standard usage conditions. The standard usage conditions refer to the following conditions. The magnetic starter may fail if it is used under environmental or atmospheric conditions other than those described below.

- a. Ambient Temperature : Standard 20°C, range of usage ambient temperature: -10°C to 40°C (Maximum average temperature during a day: 35°C, Maximum average temperature for a year: 25°C)
- b. Maximum temperature inside the control panel : 55°C. For boxed MS type, the ambient temperature should be 40°C (the annual average temperature in the panel should be 40°C or less)
It is necessary to pay attention to the ambient temperature as it influences the operational properties of the magnetic contactor and the thermal relay. The insulation will proceed to degrade even in normal usage. Especially if the ambient temperature rises, the life span of the insulation shortens. Generally, whenever the ambient temperature rises by 6 to 10°C, the life span of the insulation halves. (Arrhenius law)
- c. Relative Humidity : 45 to 85% RH, provided that there should be no condensation or freezing.
- d. Altitude : 2000m or less
- e. Oscillation : 10 to 55Hz 19.6m/s² or less
- f. Impact : 49m/s² or less
- g. Atmosphere : Must not contain too much water vapor, oil vapor, dust, smoke, corrosive gases or salt.
Contact can be interrupted if the magnetic starter is used consecutively for a long time in an airtight environment.
Never use this magnetic starter in places where there is a possibility of generation of combustible gases.
- h. Storage Temperature : -30°C to 65°C, provided that there should be no condensation or freezing.

The summarized temperature range applicable to the MS-T series is shown in Table 1.

Table 1

Temperature		Usage Temperature [°C]	Storage Temperature [°C]
Standard	Boxed MS-T type	-10 to 40	-30 to 65
Models	Open MSO-T type	-10 to 55	-30 to 65

Note a) Storage temperature is the ambient temperature during transportation and storage, and it must be within the specified range of usage temperature at the time of commencement of usage.

Note b) Set the conditions such that there is no condensation or freezing due to sudden temperature change.

2. Application to the Special Environment

2.1 High Temperature

If the magnetic starter is used at high ambient temperature, the temperature is mainly determined by the life span of the operating coil (continuous current life span) and the gradual change of the molding.

According to the standard, the temperature rise of the operating coil is specified as follows: 125°C or less for A type insulation and 140°C or less for E type insulation including the ambient temperature. However, to facilitate long term usage for MSO-T and S-T series at 55°C temperature in the panel, the temperature rise using E type insulation or higher is limited to values lower than A type insulation.

In order to estimate the continuous current life span of the operating coil, an acceleration test of continuous current on the electromagnet was performed as indicated below. As a result, there was no abnormality, such as burnout.

Thermostatic Premises Temperature : 80°C

Voltage Applied to Operating Coil : 110% of rated voltage (60Hz)

Continuous Current Passage Time : 5000 hours

Number of Test Items : 5 units of operating electromagnets for each frame

Test Results : No occurrence of burnout, no abnormality in surge comparison test

The continuous current life span of the operating coil is determined by the degradation of the winding material, and it is as shown in Figure 1 according to Arrhenius law. From this result, we can assume that the insulation lifespan of the operating coil is the average ambient temperature + temperature rise of the coil, but it generally has a life span of 10 years.

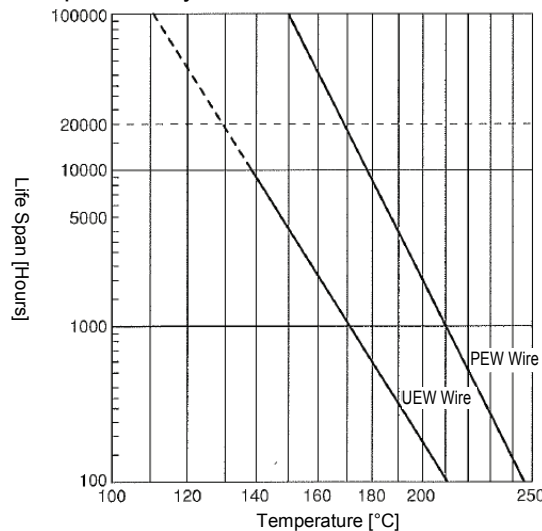

Figure 1: Magnet Wire Heat-resistance Life Span Curve
(according to the Technical Report of The Institute of Electrical Engineers of Japan)

To investigate the gradual change of the molding, an acceleration test is implemented at 120°C after having a surplus of 105°C over the ambient temperature 40°C and a rated value 65°C of the temperature rise at the terminal. The test time is set to 300 hours because the molding (mainly phenol resin) requires to be saturated at 120°C for 300 hours for gradual change to occur.

The results of the heating test of 300 hours at 120°C are shown in Table 1. This result indicates that there was no problem with the gradual changes due to temperature with respect to the MS-T series.

Table 1: Heating test results for MSO-T type

Time Properties Model Name	0			300		
	Operating Voltage [V 60Hz]	Open Voltage [V 60Hz]	Open Time [ms]	Operating Voltage [V 60Hz]	Open Voltage [V 60Hz]	Open Time [ms]
MSO-T10	139	88	14	142	87	13
MSO-T12	139	95	12	140	90	12
MSO-T20	139	106	12	140	104	12
MSO-T21	145	90	9	145	88	9
MSO-T25	145	90	9	146	88	9
MSO-T35	146	115	9	151	120	9
MSO-T50	146	115	9	151	120	9
MSO-T65	120	65	48	123	63	45
MSO-T80	120	65	48	123	63	45
MSO-T100	121	75	74	124	72	70

Note a) A nominal value of 200VAC was used for the rated value of the operating coil.

2.2 Low Temperature

The magnetic starter and the magnetic contactor that are installed in a panel may be transported to a cold area or be used in intense cold conditions such as in a cold area or freezing machine. In this case, the cold resistance will be a problem, but the standard S-T type magnetic contactors can be used in low temperatures.

- Storage Temperature -60°C or more

There was no abnormality found in any part when a shelf test was performed at -70°C for 1 month. Therefore, it can be considered that the products can withstand storage at -60°C or more.

Also, the panels transported to cold areas are usually waterproof, and packed against moisture, and when panels packed in warm areas reach cold areas, it is necessary to take into account the potential damage to the utensil due to condensation or freezing. Therefore it is vital to pay attention to the dehumidification inside the packaging, and it is advisable to use silica gel as a drying agent in the amount of 3kg per 1m².

- Usage Temperature -50°C or more

Mechanical durability test was performed according to the following conditions.

Temperature	: -50°C
Voltage Applied to Coil and Frequency	: 240V and 60Hz for 200VAC coil
Switching Frequency	: 120 times per hour
Usage Factor	: 0.66%
Usage Frequency	: 3 months (250000 times)

Since there was no damage to the parts during or after the test, the products can be used at temperatures higher than -50°C.

During usage at cold temperatures or storage, if the temperature suddenly returns to 0°C or higher, condensation occurs, and if the temperature returns to the low temperature again, condensation or freezing occurs. Therefore, it should be noted that an operational failure or contact failure may occur if condensation or freezing forms on the sliding parts of moving components or the contact surface.

3. Instantaneous Voltage Drop Tolerance

The guaranteed range of the operating voltage of the magnetic starter and the magnetic contactor is 85 to 110% of the rated voltage of the operating coil. However, according to the voltage drop during the first current supplied to the motor, the attraction force of the electromagnet drops from the time when the contact surface is touched as shown in Figure 1, and if the attraction force falls below the opposing force, the contact floats, repeating close circuit → voltage recovery → reclosing → voltage drop → open circuit at high frequency (2), and contact welding or contact element fusing may occur. (1) is the state after contact chattering is controlled and contact welding tolerance is improved, by balancing the attraction force and opposing force for enduring as much as possible in such conditions for MS-T series.

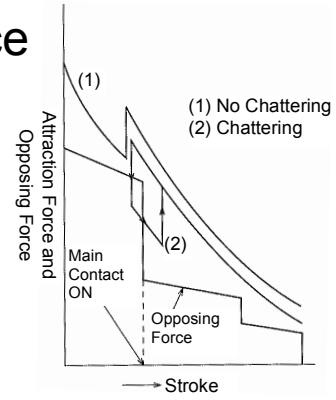
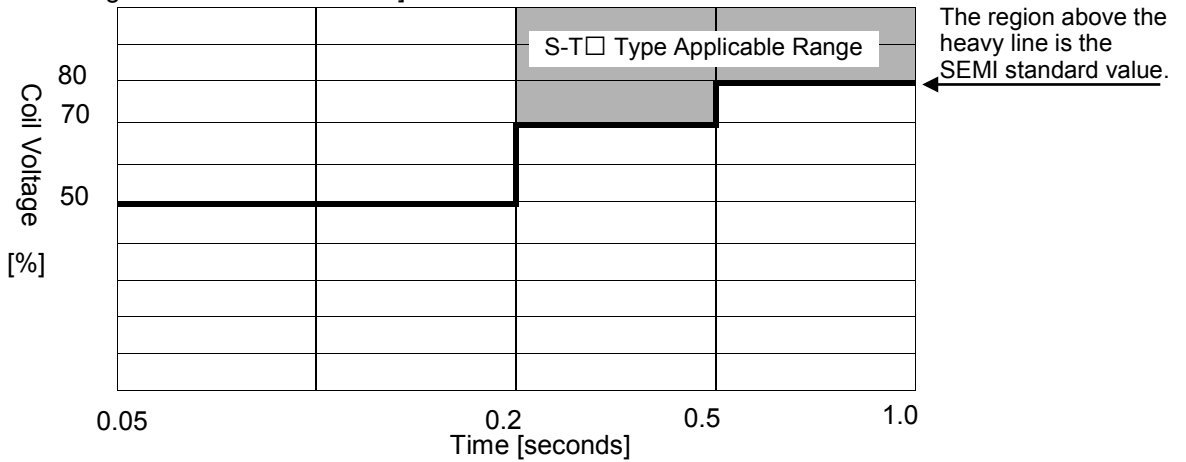

Figure 1: Attraction force property of the electromagnet due to the voltage drop when the motor is started

3.1 SEMI-F47 Standard

The magnetic contactor is not directly based on the SEMI standard because this standard demands an instantaneous voltage drop tolerance for the semiconductor equipment. However, the instantaneous voltage drop tolerance (that is tolerance when the contact is not turned off even after instantaneous voltage drop occurs in the coil excitation state) test was conducted for the S-T type and SD-T type magnetic contactors under SEMI-F47 standard. The AC-operated magnetic contactor is applicable in a certain range. The DC-operated magnetic contactor is applicable to the SEMI-F47 standard.

[AC-operated magnetic contactor S-T□]



[DC-operated magnetic contactor SD-T□]

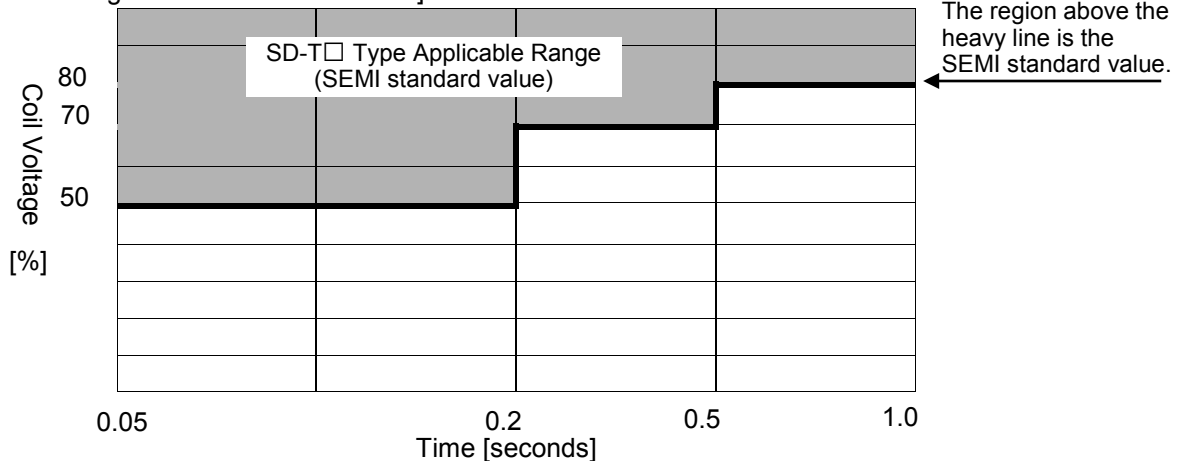

3.2 Instantaneous Power Failure Tolerance

The following table shows the maximum instantaneous power failure time during instantaneous power failure of the MS-T series.

Model Name	Maximum Instantaneous Power Failure Time [ms]
S-T10	2
S-T12, T20	2
S-T21, T25	2
S-T32	2

Model Name	Maximum Instantaneous Power Failure Time [ms]
S-T35, T50	2
S-T65, T80	40
S-T100	30

Note. This table shows the maximum instantaneous power failure time when self-maintenance (Auxiliary contact a) is functioning properly.

4. Operating Characteristics of the Thermal Relay

4.1 Operations in a Balanced Circuit (Ambient Temperature: 20°C)

- (a) If the thermal relay does not function at 105% of settling current in cold conditions for more than 2 hours, the operation should be performed with 120% of the settling current for less than 2 hours after the constant temperature is maintained.
- (b) When 150% of the settling current is passed after the settling current is passed and the constant temperature is maintained, the relay should operate within the limits shown in the table below with respect to the corresponding trip class.
- (c) The operation should be performed within the limits shown in the table below with respect to the corresponding trip class, when 720% of the settling current is passed in cold conditions.

Trip Class	150% of the settling current	720% of the settling current
5	Less than 2 minutes	$T_P \leq 5$ seconds
10A	Less than 2 minutes	$2 < T_P \leq 10$ seconds
10	Less than 4 minutes	$4 < T_P \leq 10$ seconds
20	Less than 8 minutes	$6 < T_P \leq 20$ seconds
30	Less than 12 minutes	$9 < T_P \leq 30$ seconds

T_P : Operating time at the time of constraint

4.2 Operations in an Unbalanced Circuit (Ambient Temperature: 20°C)

- (a) If the open phase detection function does not execute when settling current is passed to all poles at the same time for 2 hours, the operation should be performed within 2 hours when one pole is disconnected and 132% of settling current is passed to the other two poles after the constant temperature is maintained.
- (b) If the open phase detection function does not execute when settling current is passed to 2 poles and 90% of settling current to 1 pole for 2 hours, the operation should be performed within 2 hours when one pole is disconnected and 115% of settling current is passed to the other two poles after the constant temperature is maintained.

Result: The whole frame satisfies the above condition.

Operational property curve is shown below.

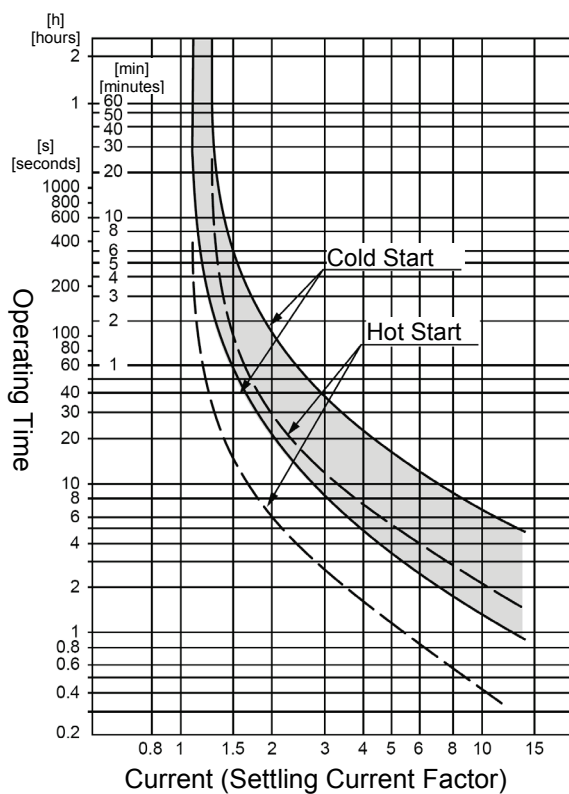

MS/MSO-T10 (KP) Type
 MS/MSO-T12 (KP) Type
 MSO-T20 (KP) Type

TH-T18 (KP) Type
 Thermal Relay

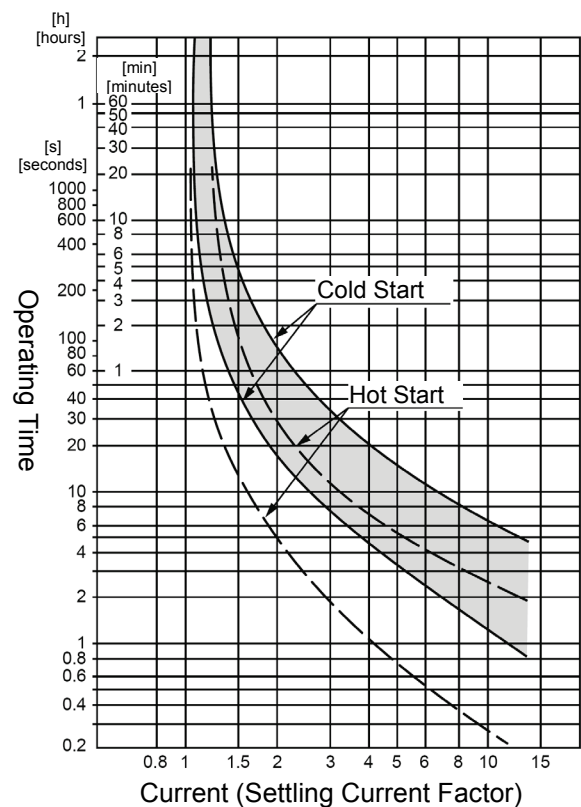

MS/MSO-T21 (KP) Type
 MSO-T25 (KP) Type

TH-T25 (KP) Type
 Thermal Relay

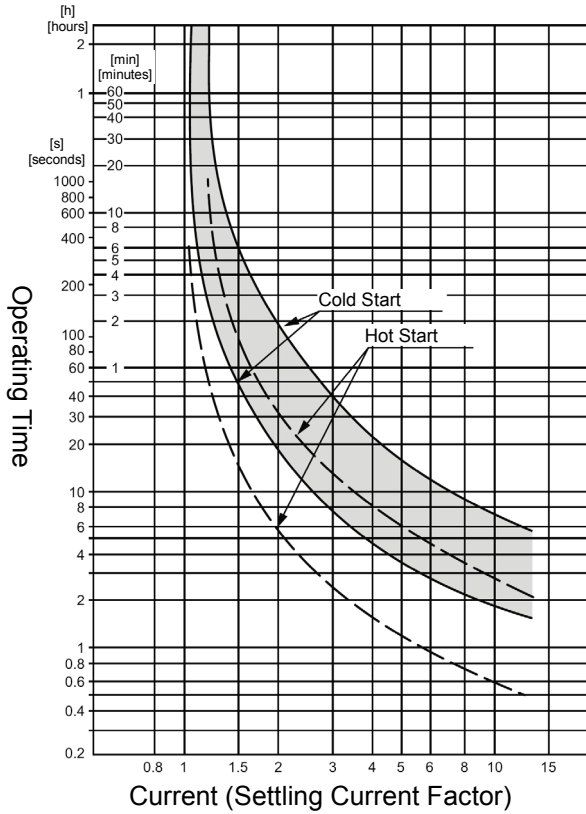

MSO-T35 (KP) Type
MSO-T50 (KP) Type

TH-T50 (KP) Type
Thermal Relay

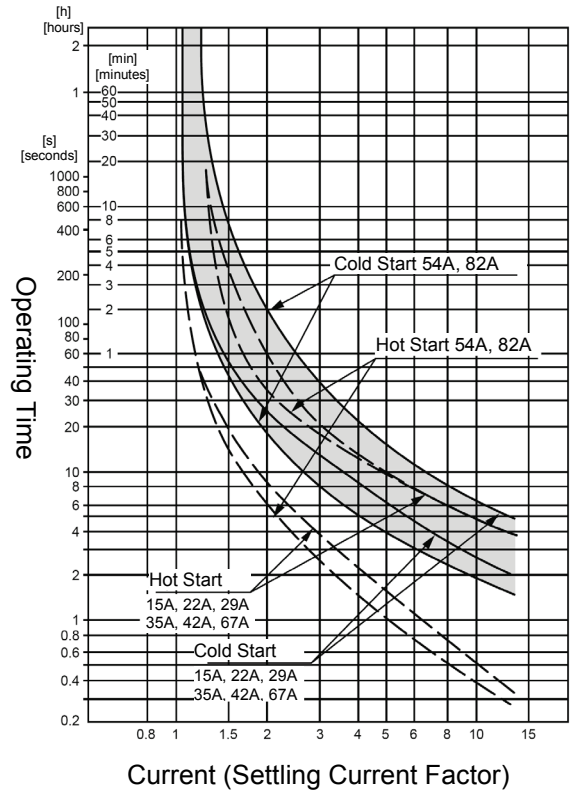

MSO-T65 (KP) Type
MSO-T80 (KP) Type
MSO-T100 (KP) Type

TH-T65 (KP) Type
TH-T100 (KP) Type
Thermal Relay

5. Noise Characteristics

The S-T10 to T50 type magnetic contactors use the optimum design of the electromagnet and oscillation insulation, while the S-T65 to T100 type magnetic contactors use AC-operated and DC excitation electromagnets. Thus, the measures to control the whining sound of core are implemented for a silent series.

5.1 Noise during the ON State

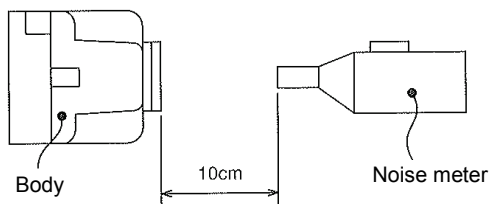

Test Conditions: Operating Coil Rated Value 200VAC

Background noise in a soundproof room:

30 dB

Measurement after every 30 cycles in A-weighting characteristic Fast.

Table 1: Noise during the ON state [dB, A-weighting Characteristic Fast]

Voltage Applied to Coil / Model Name	170V 60Hz	200V 60Hz	240V 60Hz
	Average Value	Average Value	Average Value
S-T10/T12/T20	33	33	35
S-T21/T25	30	31	32
S-T32	30	31	30
S-T35	32	32	33
S-T50	32	32	33

Note a) Indicates the average value of every 10 machines.

5.2 Noise during Opening and Closing

Table 2 shows the results when noise during opening and closing at 240V and 60Hz was measured from a distance of 10cm (other measurement conditions are the same as that of section 5.1).

Table 2: Noise during opening and closing [dB, A-weighting Characteristic Fast]

Model Name	Noise	
	When closed	When opened
S-T10/T12/T20	88	87
S-T21/T25	94	92
S-T32	91	90
S-T35	94	91
S-T50	94	91
S-T65	98	98
S-T80	98	98
S-T100	98	98

Note a) Indicates the average value of every 4 machines.

6. Impact during Opening and Closing

When the magnetic starter/magnetic contactor is installed in the control panel and opened and closed, the kinetic energy at the stop position of the movable part is converted into impact energy, and the control panel vibrates. These vibrations are transmitted to the other controllers installed on the control panel, causing a malfunction. The magnitude of these vibrations (acceleration, frequency) differs according to the magnitude of the opening-closing impact of the magnetic contactor or specifications of the control panel (hardness, number of the installed fixtures, position of installation, etc.). The existence of malfunction cannot be determined unless the measurement is performed for each case. Therefore, the test was conducted for impact acceleration and relay contact malfunctions on the standard panel of the MS-T series as shown in Figure 1.

Figure 1.

Open-close impact values (acceleration [m/s²] at a frequency of 0 to 2000Hz)

Model Name	240V 50Hz
S-T10	14.7 to 19.6
S-T12/T20	14.7 to 19.6
S-T21/T25	14.7 to 19.6
S-T32	14.7 to 19.6
S-T35	14.7 to 24.5
S-T50	14.7 to 24.5
S-T65	14.7 to 24.5
S-T80	14.7 to 24.5
S-T100	24.5 to 39.2

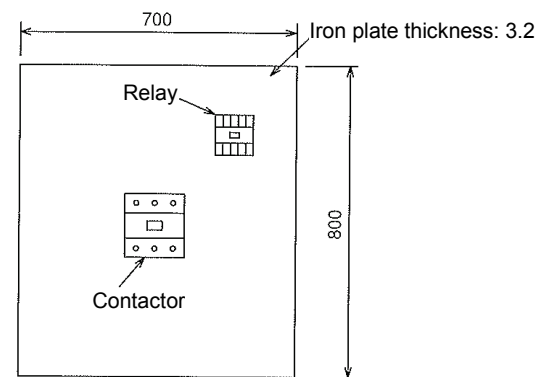

Figure 1: Standard panel for the open and close impact test

Contact malfunction due to open-close impact of the installed plate

Impact making body	S-T10 to T100 (by applying voltage of 240V and frequency of 50Hz to the 200VAC coil)
Impact receiving body	SR-T9 5a4b
Results	The contact b did not malfunction.

7. Insulation Resistance and Withstand Voltage

	Reference Value	Results	Measurement Locations
Insulation Resistance	5MΩ or more	100MΩ or more for all frames	(a) Between conducting part and grounded metal body as well as the operating circuit (grounded) when the contact element was closed. (b) Between all poles when the contact element was closed. (c) Between conducting part and grounded metal body as well as the operating circuit (grounded) when the contact element was opened.
Withstand Voltage	Endurance for 1 minute at 2500V and 50Hz or 60Hz	No abnormality for 1 minute at 2500V and 60Hz for all the frames	(d) Between the supply side terminals and the load side terminals when the contact element was opened. (e) Between the conducting part of the operating circuit and the grounded metal body. (f) Between one circuit of the operating circuit, and all other circuits (grounded).

8. Vibration

8.1 Contact Malfunction Vibration

Investigation of resonance point existence and contact malfunction existence by slowly increasing the frequency from 10Hz to 55Hz, and then slowly decreasing it from 55Hz to 10Hz according to the following conditions.

Conditions

Acceleration : Constant at 19.6m/s²

Vibration Direction : Front-Back, Right-Left, Up-Down

Frequency Variable Speed : 2Hz per second

Check Items : Resonance point existence, contact malfunction existence (contact malfunction check according to the following points)

Magnetic Contactor : The existence of contact b malfunction was checked when the operating coil was OFF.

The existence of main or auxiliary contact a malfunction was checked when the operating coil was ON (applying 85% of the rated voltage).

Thermal Relay : The existence of contact a malfunction was checked when there was no current trip state.

The existence of contact b malfunction was checked after the smallest current of the scale was passed, and the temperature was saturated.

Judgment Conditions

Resonance Point : Should be none

Contact Malfunction : Contact should not be left open for more than 1ms

Results

There was no malfunction in the resonance point or contact of S-T10 to T100 type and TH-T18 to T100 type.

8.2 Constant Vibration Endurance

One-hour test was conducted in each state and in each direction for a total of six hours according to the following conditions to check for change in properties, damage, and looseness before and after the test.

Conditions

Frequency : 16.7Hz

Double Amplitude : 4mm

Vibration Direction : Front-Back, Right-Left, Up-Down

Check items : The existence of change in properties, damage to the parts, loose screws, or contact malfunction (contact malfunction check according to the following points)

Magnetic Contactor : The existence of contact b malfunction was checked when the operating coil was OFF.

The existence of main or auxiliary contact a malfunction was checked when the operating coil was ON (applying 85% of the rated voltage).

Thermal Relay : The existence of contact a malfunction was checked when there was no current trip state.

The existence of contact b malfunction was checked after the smallest current of the scale was passed, and the temperature was saturated.

Screw Tightening Torque: Tightening at 80% of the reference torque

Judgment Conditions

Change in Property : The change in operating voltage of the magnetic contactor should be ±2% or less UTC (Minimum operating current) change of the thermal relay should be within 5%

Damage : No part should be damaged

Looseness : No screw should be loose

Contact Malfunction : Contact should not be left open for more than 1ms

Results

For S-T10 to T100 type and TH-T18 to T100 type, there was no contact malfunction, or damage to any parts, or looseness of the screws and the property change was within the reference value.

9. Impact

Investigation of contact malfunction or damage by applying the sine wave pulse impact.

Impact Waveform: Figure on right side

Impact Count: 5 times per direction (3 times when the operating coil was OFF, and 2 times when it was ON)

Judgment conditions:

Contact malfunction: 49m/s^2 or more

Damage to parts: 490m/s^2 or more

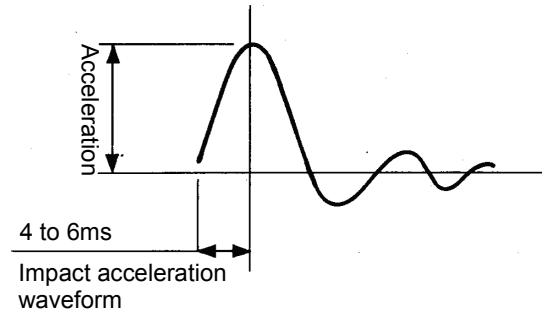

Model Name	Test Conditions				Testing Machine	Results	
	Thermal Relay		Operating Coil			49m/s^2	490m/s^2
	Nominal Value [A]	Passage of Current [A]	Voltage [V]	Frequency [Hz]			
MSO-T10	9	7	170	60	Pendulum	No contact malfunction	No damage
MSO-T12	11	9	170	60	Pendulum	No contact malfunction	No damage
MSO-T20	15	12	170	60	Pendulum	No contact malfunction	No damage
MSO-T21	15	12	170	60	Pendulum	No contact malfunction	No damage
MSO-T25	22	18	170	60	Pendulum	No contact malfunction	No damage
MSO-T35	29	24	170	60	Pendulum	No contact malfunction	No damage
MSO-T50	42	34	170	60	Pendulum	No contact malfunction	No damage
MSO-T65	54	43	170	60	Pendulum	No contact malfunction	No damage
MSO-T80	67	54	170	60	Pendulum	No contact malfunction	No damage
MSO-T100	82	65	170	60	Pendulum	No contact malfunction	No damage

Note a) A nominal value of 200VAC was used for the rated value of the operating coil.

Note b) The coil was switched on 1 hour after the start of current passage.

10. Mechanical Endurance

In the test conditions indicated in Table 1, the operation was performed specified number of times. As a result, there was no damage to the parts, etc. There was no abnormality in the operation even after the test, meeting the standard criteria.

Table 1

Model Name	Test Conditions				Results			
	Operating Circuit Voltage [V]	Frequency [Hz]	Switching Frequency [times per hour]	Number of Switching Times [10000 times]	Damage to Parts	Looseness of tightened parts	Operating Test after Number of Switching Times	
							Operating Voltage [V]	Open Voltage [V]
Standard	Rated Voltage	Rated Frequency	-	-	None	None	85% or less of the Coil Rated Voltage	20 to 75% (S-T50 or less) 10 to 75% (S-T65 or more) of Coil Rated Voltage
S-T10	240	60	14400	1000	None	None	140 to 150	108 to 120
S-T12	240	60	14400	1000	None	None	144 to 155	107 to 130
S-T20	240	60	14400	1000	None	None	144 to 155	107 to 130
S-T21	240	60	14400	1000	None	None	148 to 151	109 to 120
S-T25	240	60	14400	1000	None	None	148 to 151	109 to 120
S-T32	240	60	14400	1000	None	None	147 to 154	100 to 104
S-T35	240	60	14400	1000	None	None	138 to 149	110 to 118
S-T50	240	60	14400	1000	None	None	138 to 149	110 to 118
S-T65	240	60	7200	500	None	None	108 to 118	35 to 50
S-T80	240	60	7200	500	None	None	108 to 118	35 to 50
S-T100	240	60	7200	500	None	None	106 to 122	55 to 85

11. Electrical Endurance

AC-3 class

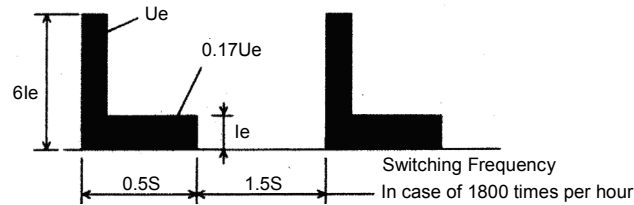

200V/440V

Item Standard	Test Conditions				Number of Tests [10000 times]	Insulation Resistance [MΩ]	Withstand Voltage [VAC 1 minute]
	Voltage Ur [3φ, V]	Current Ie [A]	Power Factor [Delay]	Switching Frequency [times per hour]			
Model Name	*1	*2	Ie ≤ 17A : 0.65 Ie > 17A : 0.35	-	-	-	2 x Ue
S-T10	220 440	11 7	0.65 "	1800 "	200 "	100 or more	2500 OK
S-T12	220 440	13 9	0.65 "	1800 "	200 "	"	"
S-T20	220 440	18 18	0.35 "	1800 "	200 100	"	"
S-T21	220 440	20 20	0.35 "	1800 "	200 "	"	"
S-T25	220 440	26 25	0.35 "	1800 "	200 "	"	"
S-T32	220 440	32 32	0.35 "	1800 "	200 "	"	"
S-T35	220 440	35 32	0.35 "	1800 "	200 "	"	"
S-T50	220 440	50 48	0.35 "	1200 "	200 "	"	"
S-T65	220 440	65 65	0.35 "	1200 "	200 "	"	"
S-T80	220 440	80 80	0.35 "	1200 "	100 "	"	"
S-T100	220 440	100 93	0.35 "	1200 "	100 "	"	"

Note a) *1 Closed circuit voltage: Rated applicable voltage (Ue), break-time voltage: Ue x 0.17 times
*2 Closed circuit current: Rated applicable current (Ie) x 6 times, break-time current: Ie

AC-4 class

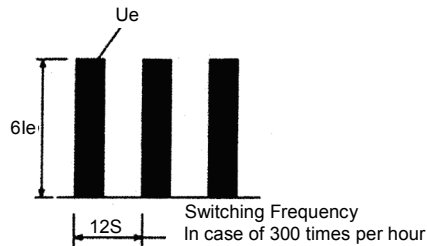

200V/440V

Item Standard	Test Conditions				Number of Tests [10000 times]	Insulation Resistance [MΩ]	Withstand Voltage [VAC 1 minute]
	Voltage Ur [3φ, V]	Current Ie [A]	Power Factor [Delay]	Switching Frequency [times per hour]			
Model Name	*3	*4	Ie ≤ 17A : 0.65 Ie > 17A : 0.35	-	-	-	2 x Ue
S-T10	220 440	8 6	0.65 "	300 "	3 "	100 or more	2500 OK
S-T12	220 440	11 9	0.65 "	300 "	3 "	"	"
S-T20	220 440	18 13	0.35 0.65	300 "	1.5 "	"	"
S-T21	220 440	18 13	0.35 0.65	300 "	3 "	"	"
S-T25	220 440	20 17	0.35 0.65	300 "	3 "	"	"
S-T32	220 440	26 24	0.35 "	300 "	3 "	"	"
S-T35	220 440	26 24	0.35 "	300 "	3 1.5	"	"
S-T50	220 440	35 32	0.35 "	300 "	3 1.5	"	"
S-T65	220 440	50 47	0.35 "	300 "	3 1.5	"	"
S-T80	220 440	65 62	0.35 "	300 "	3 1.5	"	"
S-T100	220 440	80 75	0.35 "	300 "	3 1.5	"	"

Note a) *3 Closed circuit voltage: Rated applicable voltage (Ue), break-time voltage: Ue
*4 Closed circuit current: Rated applicable current (Ie) x 6 times, break-time current: Ie x 6 times

12. Short Time Current Overload Tolerance of the Magnetic Contactor

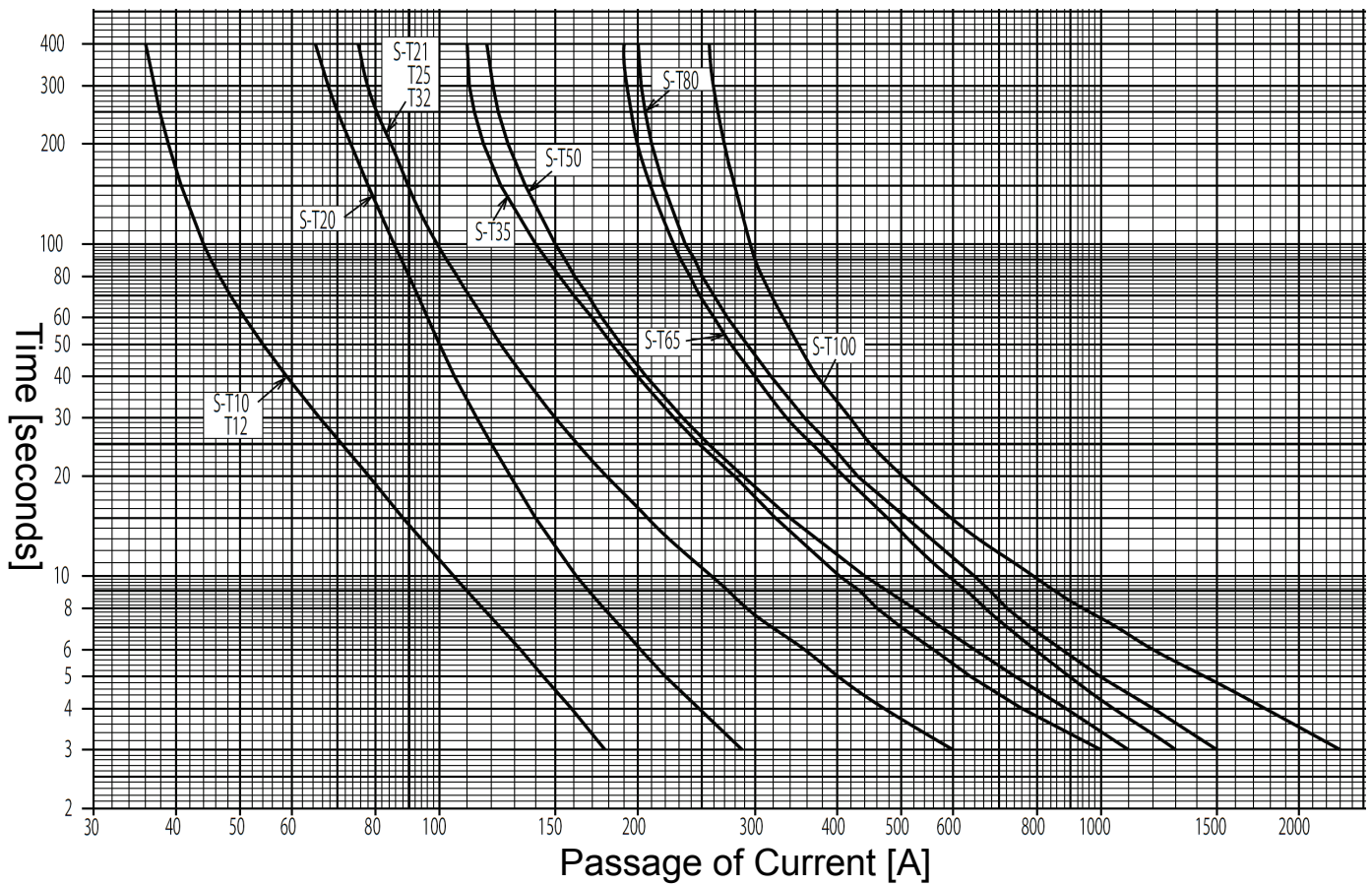

Note a) Indicates the relationship between the time and the passage of current up to a certain temperature at which the temperature rise value of the contact element of the magnetic contactor will not cause hindrance to the continuous use of the contactor.

Magnetic Contactors and Magnetic Starters

INSTRUCTION MANUAL

 **Safety Warning**

To ensure proper use of the products listed in this catalog, please be sure to read the instruction manual prior to use.

Mitsubishi Electric Corporation Nagoya Works is a factory certified for ISO 14001 (standards for environmental management systems).



MITSUBISHI ELECTRIC CORPORATION

HEAD OFFICE : TOKYO BLDG., 2-7-3, MARUNOUCHI, CHIYODA-KU, TOKYO 100-8310, JAPAN
www.MitsubishiElectric.co.jp/melfansweb