

CC-Link **IE** Field

A800-GF FR-A802-GF (SEPARATED CONVERTER TYPE) INSTRUCTION MANUAL (HARDWARE)

FR-A842-07700(315K) to 12120(500K)-GF

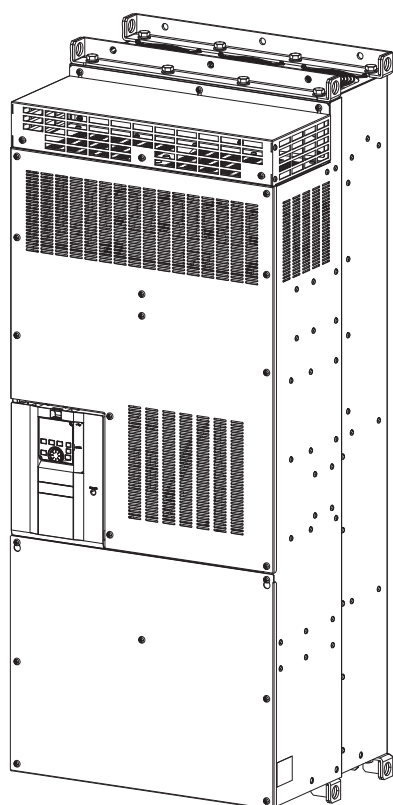

INTRODUCTION	1
INSTALLATION AND WIRING	2
PRECAUTIONS FOR USE OF THE INVERTER	3
PROTECTIVE FUNCTIONS	4
PRECAUTIONS FOR MAINTENANCE AND INSPECTION	5
SPECIFICATIONS	6

Thank you for choosing this Mitsubishi Electric inverter.

This Instruction Manual describes handling and cautions about the hardware, such as installation and wiring, for the FR-A802 (separated converter type) that are different from the FR-A800.

Information about the software, such as basic operations and parameters, is described in the FR-A800 Instruction Manual (Detailed) in the CD-ROM enclosed with the product.

In addition to this manual, please read the manuals in the enclosed CD-ROM carefully. Do not use this product until you have a full knowledge of the equipment, safety information and instructions.

Please forward this Instruction Manual to the end user.

Safety Instructions

Do not attempt to install, operate, maintain or inspect this product until you have read through this Instruction Manual (Detailed) and supplementary documents carefully and can use the equipment correctly. Do not use this product until you have a full knowledge of this product mechanism, safety information and instructions.

Installation, operation, maintenance and inspection must be performed by qualified personnel. Here, an expert means a person who meets all the conditions below.

- A person who took a proper engineering training. Such training may be available at your local Mitsubishi Electric office. Contact your local sales office for schedules and locations.

- A person who can access operating manuals for the protective devices (e.g. light curtain) connected to the safety control system. A person who has read and familiarized himself/herself with the manuals.

In this Instruction Manual (Detailed), the safety instruction levels are classified into "WARNING" and "CAUTION"



WARNING Incorrect handling may cause hazardous conditions, resulting in death or severe injury.



CAUTION Incorrect handling may cause hazardous conditions, resulting in medium or slight injury, or may cause only material damage.

The **CAUTION** level may even lead to a serious consequence according to conditions. Both instruction levels must be followed because these are important to personal safety.

Electric Shock Prevention



WARNING

- Do not remove the front cover or the wiring cover while the power of this product is ON, and do not run this product with the front cover or the wiring cover removed as the exposed high voltage terminals or the charging part of the circuitry can be touched. Otherwise you may get an electric shock.
- Even if power is OFF, do not remove the front cover except for wiring or periodic inspection. You may accidentally touch the charged inverter circuits and get an electric shock.
- Before wiring or inspection, LED indication of the operation panel must be switched OFF. Any person who is involved in wiring or inspection shall wait for at least 10 minutes after the power supply has been switched OFF and check that there are no residual voltage using a tester or the like. The capacitor is charged with high voltage for some time after power OFF, and it is dangerous.
- This product must be earthed (grounded). Earthing (grounding) must conform to the requirements of national and local safety regulations and electrical code (NEC section 250, IEC 61140 class 1 and other applicable standards). A neutral-point earthed (grounded) power supply inverter in compliance with EN standard must be used.
- Any person who is involved in wiring or inspection of this product shall be fully competent to do the work.
- This product body must be installed before wiring. Otherwise you may get an electric shock or be injured.
- Do not touch the setting dial or keys with wet hands. Doing so may cause an electric shock.
- Do not subject the cables to scratches, excessive stress, heavy loads or pinching. Doing so may cause an electric shock.
- Do not change the cooling fan while power is ON as it is dangerous to change the cooling fan while power is ON.
- Do not touch the printed circuit board or handle the cables with wet hands. Doing so may cause an electric shock.
- Before wiring or inspection for a PM motor, confirm that the PM motor is stopped as a PM motor is a synchronous motor with high-performance magnets embedded inside and high-voltage is generated at the motor terminals while the motor is running even after the power of this product is turned OFF. In an application, such as fan and blower, that the motor may be driven by the load, connect a low-voltage manual contactor at this product output side and keep it open during wiring and inspection of this product. Otherwise you may get an electric shock.

Fire Prevention



CAUTION

- Inverter must be installed on a nonflammable wall without holes (so that nobody touches the inverter heat sink on the rear side, etc.). Installing it to or near flammable material may cause a fire.
- If the inverter becomes faulty, the inverter power must be switched OFF. A continuous flow of large current may cause a fire.
- Be sure to perform daily and periodic inspections as specified in the Instruction Manual. There is a possibility of explosion, damage, or fire if this product is used without inspection.

Injury Prevention



CAUTION

- The voltage applied to each terminal must be the ones specified in the Instruction Manual. Otherwise an explosion or damage may occur.
- The cables must be connected to the correct terminals. Otherwise an explosion or damage may occur.
- The polarity (+ and -) must be correct. Otherwise an explosion or damage may occur.
- While power is ON or for some time after power-OFF, do not touch the inverter as it will be extremely hot. Touching these devices may cause burns.

Additional Instructions

The following instructions must be also followed. If the product is handled incorrectly, it may cause unexpected fault, an injury, or an electric shock.



CAUTION

Transportation and installation

- To prevent injury, wear cut-resistant gloves when opening packaging with sharp tools.
- Use proper lifting techniques or a trolley when carrying products.
- Do not stand or rest heavy objects on the product.
- Do not stack the boxes containing inverters higher than the number recommended.
- When carrying the inverter, do not hold it by the front cover; it may fall off or fail.
- During installation, caution must be taken not to drop the inverter as doing so may cause injuries.
- The product must be installed on a surface that withstands the weight of the inverter.
- Do not install the product on a hot surface.
- Ensure the mounting orientation of this product is correct.
- Ensure this product is mounted securely in its enclosure.
- Do not install or operate the inverter if it is damaged or has parts missing.
- Foreign conductive objects must be prevented from entering the inverter. That includes screws and metal fragments or other flammable substance such as oil.
- As the inverter is a precision instrument, do not drop or subject it to impact.
- The surrounding air temperature for LD, ND (initial setting), and HD models must be between 0 and +50°C (non-freezing). The surrounding air temperature for SLD must be between 0 and +40°C (non-freezing). Otherwise the inverter may be damaged.
- The ambient humidity must be 95% RH or less (non-condensing). Otherwise the inverter may be damaged. (Refer to [page 17](#) for details.)

⚠ CAUTION

Transportation and installation

- The storage temperature (applicable for a short time, e.g. during transit) must be between -20 and +65°C. Otherwise the inverter may be damaged.
- The inverter must be used indoors (without corrosive gas, flammable gas, oil mist, dust and dirt etc.) Otherwise the inverter may be damaged.
- Do not use this product at an altitude above 2500 m. Vibration should not exceed 2.9 m/s² at 10 to 55 Hz in X, Y, and Z directions. Otherwise this product may be damaged. (For the installation at an altitude above 1000 m, consider a 3% reduction in the rated current per 500 m increase in altitude.)
- If halogens (including fluorine, chlorine, bromine, and iodine) contained in fumigants for wood packages enter this product, the product may be damaged. Prevent the entry of fumigant residuals or use an alternative method such as heat disinfection. Note that sterilization or disinfection of wood packages should be performed before packing the product.

Wiring

- Do not install a power factor correction capacitor, surge absorber, or radio noise filter on the output side of this product. These devices may overheat or burn out.
- The output terminals (terminals U, V, and W) must be connected to a motor correctly. Otherwise the motor will rotate inversely.
- PM motor terminals (U, V, W) hold high-voltage while the PM motor is running even after the power is turned OFF. Before wiring, the PM motor must be confirmed to be stopped. Otherwise you may get an electric shock.
- Never connect a PM motor to a commercial power supply. Connecting a commercial power supply to the input terminals (U, V, W) of a PM motor will burn it out. The PM motor must be connected with the output terminals (U, V, W) of the inverter.

Test operation

- Before starting operation, each parameter must be confirmed and adjusted. A failure to do so may cause some machines to make unexpected motions.

⚠ WARNING

Usage

- Stay away from the equipment when the retry function is set as it will restart suddenly after a trip.
-  Since pressing a key may not stop output depending on the function setting status, separate circuit and switch that make an emergency stop (power OFF, mechanical brake operation for emergency stop, etc.) must be provided.
- OFF status of the start signal must be confirmed before resetting the inverter fault. Resetting inverter fault with the start signal ON restarts the motor suddenly.
- Do not use a PM motor for an application where the PM motor is driven by its load and runs at a speed higher than the maximum motor speed.
- Use this inverter only with three-phase induction motors or with a PM motor. Connection of any other electrical equipment to the inverter output may damage the equipment.
- Performing pre-excitation (LX signal and X13 signal) under torque control (Real sensorless vector control) may start the motor running at a low speed even when the start command (STF or STR) is not input. The motor may run also at a low speed when the speed limit value = 0 with a start command input. It must be confirmed that the motor running will not cause any safety problem before performing pre-excitation.
- Do not modify the equipment.
- Do not perform parts removal which is not instructed in this manual. Doing so may lead to fault or damage of the product.

⚠ CAUTION

Usage

- The electronic thermal relay function does not guarantee protection of the motor from overheating. It is recommended to install both an external thermal and PTC thermistor for overheat protection.
- Do not use a magnetic contactor on the inverter input for frequent starting/stopping of the inverter. Otherwise the life of the inverter decreases.
- The effect of electromagnetic interference must be reduced by using a noise filter or by other means. Otherwise nearby electronic equipment may be affected.
- Appropriate precautions must be taken to suppress harmonics. Otherwise power supply harmonics from the inverter may heat/damage the power factor correction capacitor and generator.
- When driving a 400V class motor with the inverter, the motor must be an insulation-enhanced motor or measures must be taken to suppress surge voltage. Otherwise surge voltage, which is attributed to the length and thickness of wire, may occur at the motor terminals, causing the motor insulation to deteriorate.
- When parameter clear or all parameter clear is performed, the required parameters must be set again before starting operations. because all parameters return to their initial values.
- The inverter can be easily set for high-speed operation. Before changing its setting, the performances of the motor and machine must be fully examined.
- This product's brake function cannot be used as a mechanical brake. Use a separate device instead.
- Perform an inspection and test operation of this product if it has been stored for a long period of time.
- Static electricity in your body must be discharged before you touch the product.
- Only one PM motor can be connected to an inverter.
- A PM motor must be used under PM sensorless vector control. Do not use a synchronous motor, induction motor, or synchronous induction motor.
- Do not connect a PM motor in the induction motor control settings (initial settings). Do not use an induction motor in the PM sensorless vector control settings. It will cause a failure.
- In the system with a PM motor, the inverter power must be turned ON before closing the contacts of the contactor at the output side.

Emergency stop

- A safety backup such as an emergency brake must be provided for devices or equipment in a system to prevent hazardous conditions in case of failure of this product or an external device controlling this product.
- If the breaker installed on the input side of this product trips, check for wiring faults (short circuits etc.) and damage to internal parts of this product. Identify and remove the cause of the trip before resetting the tripped breaker and applying the power to the product again.
- When a protective function activates, take an appropriate corrective action, then reset the inverter, and resume the operation.

Maintenance, inspection and parts replacement

- Do not carry out a megger (insulation resistance) test on the control circuit of the inverter. It will cause a failure.

Disposal

- The inverter must be treated as industrial waste.

Application of caution labels

Caution labels are used to ensure safety during use of Mitsubishi Electric inverters.

Apply the following labels to the inverter if the "retry function" and/or "automatic restart after instantaneous power failure" have been enabled.

- For the retry function

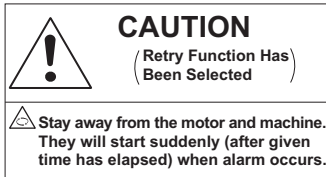

- For automatic restart after instantaneous power failure



Application of motor control labels

Apply the following labels to the inverter to avoid connecting a motor different from those intended for the motor control setting.

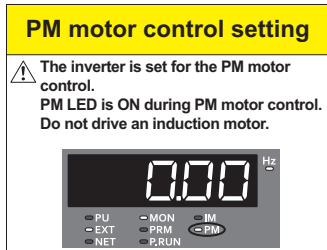
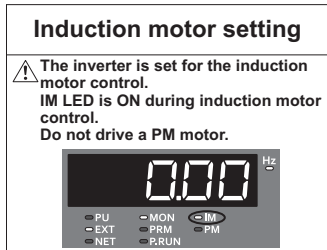

General instruction

- For clarity, illustrations in this Instruction Manual may be drawn with covers or safety guards removed. Ensure all covers and safety guards are properly installed prior to starting operation. For details on the PM motor, refer to the Instruction Manual of the PM motor.

CONTENTS

1	INTRODUCTION	7
1.1	Product checking and accessories	8
1.2	Inverter component names	9
1.3	About the related manuals	10
2	INSTALLATION AND WIRING	11
2.1	Peripheral devices	12
2.1.1	Inverter and peripheral devices	12
2.1.2	Peripheral devices	14
2.2	Removal and reinstallation of the operation panel or the front covers	15
2.3	Installation and enclosure design	17
2.3.1	Inverter installation environment	17
2.3.2	Amount of heat generated by the inverter	20
2.3.3	Cooling system types for inverter enclosure	21
2.3.4	Inverter installation	22
2.3.5	Protruding the heat sink through the panel	24
2.4	Terminal connection diagrams	26
2.5	Main circuit terminals	30
2.5.1	Details on the main circuit terminals of the inverter	30
2.5.2	Details on the main circuit terminals of the converter unit (FR-CC2)	30
2.5.3	Terminal layout of the main circuit terminals, wiring of power supply and the motor	31
2.5.4	Applicable cables and wiring length	32
2.5.5	Earthing (grounding) precautions	35
2.6	Control circuit	36
2.6.1	Details on the control circuit terminals of the inverter	36
2.6.2	Details on the control circuit terminals of the converter unit (FR-CC2)	40
2.6.3	Control logic (sink/source) change	41
2.6.4	Wiring of inverter control circuit	43
2.6.5	Wiring precautions	45
2.6.6	When using separate power supplies for the control circuit and the main circuit	46
2.6.7	When supplying 24 V external power to the control circuit	47
2.6.8	Safety stop function	49
2.7	Communication connectors and terminals	51
2.7.1	PU connector	51
2.7.2	CC-Link IE Field Network function	52
2.7.3	USB connector	54
2.7.4	RS-485 terminal block	55
2.8	Connection of motor with encoder (vector control)	56
2.9	Parameter settings for a motor with encoder	62
2.10	Connection of stand-alone option units	63
2.10.1	Connection of the brake unit (FR-BU2)	63

2.10.2	Connection of the high power factor converter (FR-HC2)	64
2.10.3	Connection of the power regeneration converter (MT-RC).....	65

3 PRECAUTIONS FOR USE OF THE INVERTER 67

3.1	Electro-magnetic interference (EMI) and leakage currents	68
3.1.1	Leakage currents and countermeasures	68
3.1.2	Countermeasures against inverter-generated EMI.....	71
3.1.3	Converter unit (FR-CC2) built-in EMC filter	74
3.2	Power supply harmonics	75
3.2.1	Power supply harmonics.....	75
3.2.2	Harmonic Suppression Guidelines in Japan.....	76
3.3	Installation of a reactor	78
3.4	Power-OFF and magnetic contactor (MC)	79
3.5	Countermeasures against deterioration of the 400 V class motor insulation	80
3.6	Checklist before starting operation	81
3.7	Failsafe system which uses the inverter	84

4 PROTECTIVE FUNCTIONS 87

4.1	Inverter fault and alarm indications	88
4.2	Reset method for the protective functions	88
4.3	Check and clear of the fault history	89
4.4	List of fault displays	91

5 PRECAUTIONS FOR MAINTENANCE AND INSPECTION 93

5.1	Inspection item	94
5.1.1	Daily inspection.....	94
5.1.2	Periodic inspection.....	94
5.1.3	Daily and periodic inspection	95
5.1.4	Checking the inverter and converter semiconductor devices	96
5.1.5	Cleaning.....	97
5.1.6	Replacement of parts.....	97
5.1.7	Removal and reinstallation of the control circuit terminal block.....	99
5.2	Measurement of main circuit voltages, currents and powers	101
5.2.1	Measurement of powers	103
5.2.2	Measurement of voltages	103
5.2.3	Measurement of currents.....	103

5.2.4	Example of measuring converter unit (FR-CC2) input power factor.....	103
5.2.5	Measurement of converter output voltage (across terminals P and N)	103
5.2.6	Measurement of inverter output frequency.....	104
5.2.7	Insulation resistance test using megger	104
5.2.8	Pressure test	104

6 SPECIFICATIONS **105**

6.1	Inverter rating	106
6.2	Common specifications	107
6.3	Outline dimension drawings	109

APPENDIX **111**

Appendix 1	For customers replacing the conventional model with this inverter	112
Appendix 2	Comparison with FR-A840	114
Appendix 3	Instructions for compliance with the EU Directives	115
Appendix 4	Instructions for UL and cUL	118
Appendix 5	Instructions for EAC.....	120
Appendix 6	Restricted Use of Hazardous Substances in Electronic and Electrical Products	121
Appendix 7	Referenced Standard (Requirement of Chinese standardized law).....	121

1 INTRODUCTION

This chapter contains the descriptions that must be read before using this product.

Always read the instructions before using the equipment.

1.1 Product checking and accessories	8
1.2 Inverter component names	9
1.3 About the related manuals	10

<Abbreviations and generic terms>

DU	Operation panel (FR-DU08)
Operation panel	Operation panel (FR-DU08) and LCD operation panel (FR-LU08)
Parameter unit	Parameter unit (FR-PU07)
PU	Operation panel and parameter unit
Inverter	Mitsubishi Electric inverter FR-A800 series (Separated converter type)
Vector control compatible option	FR-A8AP/FR-A8AL/FR-A8APA/FR-A8APR/FR-A8APS (plug-in option), FR-A8TP (control terminal option)
Pr.	Parameter number (Number assigned to function)
PU operation	Operation using the PU (operation panel/parameter unit)
External operation	Operation using the control circuit signals
Combined operation	Combined operation using the PU (operation panel/parameter unit) and External operation

<Trademarks>

- Ethernet is a registered trademark of Fuji Xerox Corporation.
- MODBUS is a registered trademark of SCHNEIDER ELECTRIC USA, INC.
- Other company and product names herein are the trademarks and registered trademarks of their respective owners.

<Notes on descriptions in this Instruction Manual>

- Connection diagrams in this Instruction Manual suppose that the control logic of the input terminal is the sink logic, unless otherwise specified. (For the control logic, refer to [page 41](#).)

Harmonic Suppression Guidelines

All the models of the inverters used by specific consumers are covered by "the Harmonic Suppression Guidelines for Consumers Who Receive High Voltage or Special High Voltage". For the details, refer to [page 76](#).

1.1 Product checking and accessories

Unpack the product and check the rating plate and the capacity plate of the inverter to ensure that the model agrees with the order and the product is intact.

● Applicable inverter model

Symbol	Voltage class	Symbol	Structure, functionality	Symbol	Description	Symbol	Type*1
4	400 V class	2	Separated converter type	07700 to 12120	Inverter SLD rated current (A)	1	FM
				315K to 500K	Inverter ND rated capacity (kW)	2	CA

FR - A 8 4 2 - 07700 - 1 - GF

Symbol	Circuit board coating*2	Plated conductor
None	Without	Without
60	With	Without
06	With	With

Symbol	Structure, functionality
GF	With built-in CC-Link IE Field Network function

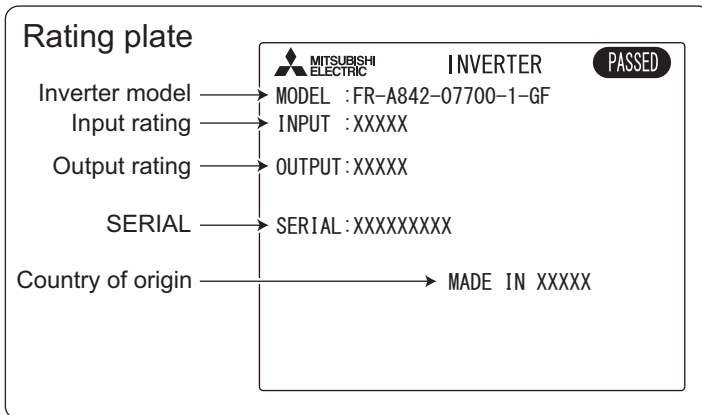
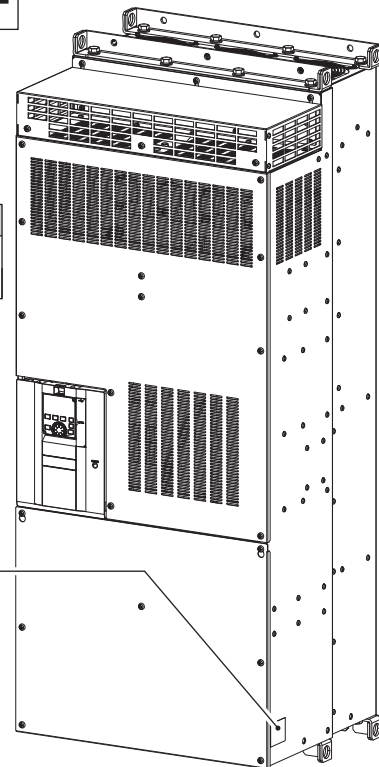

*1 Specification differs by the type as follows.

Type	Monitor output	Initial setting		
		Control logic	Rated frequency	Pr.19 Base frequency voltage
FM (terminal FM equipped model)	Terminal FM (pulse train output) Terminal AM (analog voltage output (0 to ±10 VDC))	Sink logic	60 Hz	9999 (same as the power supply voltage)
CA (terminal CA equipped model)	Terminal CA (analog current output (0 to 20 mA DC)) Terminal AM (analog voltage output (0 to ±10 VDC))	Source logic	50 Hz	8888 (95% of the power supply voltage)

*2 Conforming to IEC 60721-3-3 3C2/3S2

NOTE

- In this Instruction Manual, the inverter model name consists of the applicable motor capacity and the rated current.
(Example) FR-A842-07700(315K)

● How to read the SERIAL number

Rating plate example

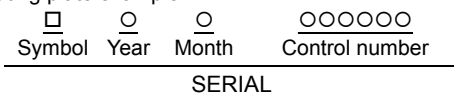

The SERIAL consists of one symbol, two characters indicating the production year and month, and six characters indicating the control number. The last digit of the production year is indicated as the Year, and the Month is indicated by 1 to 9, X (October), Y (November), or Z (December).

1.2 Inverter component names

Component names are shown below.

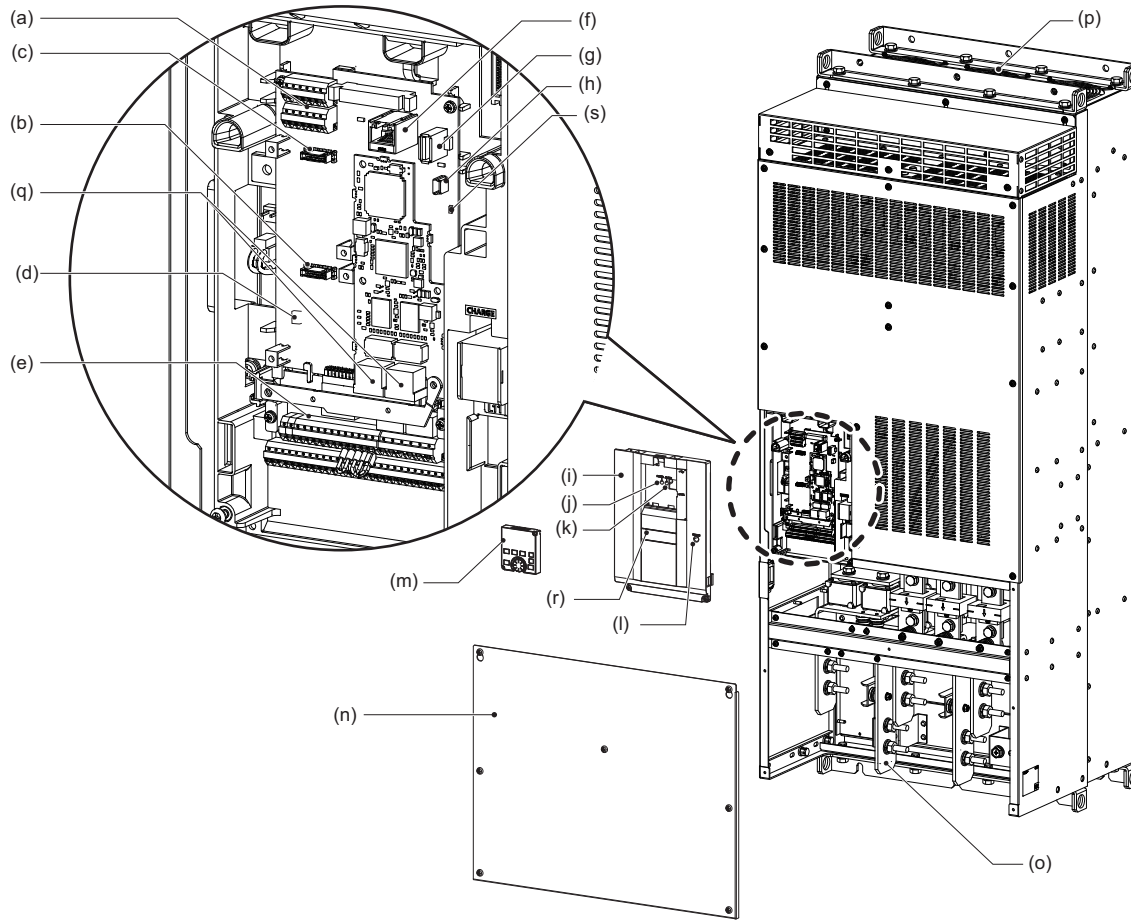

Symbol	Name	Description	Refer to page
(a)	RS-485 terminals	Enables RS-485 communication.	55
(b)	Plug-in option connector 2	Connects a plug-in option or a communication option.	Instruction Manual of the option
(c)	Plug-in option connector 3		
(d)	Voltage/current input switch	Selects between voltage and current for the terminal 2 and 4 inputs.	*1
(e)	Control circuit terminal block	Connects cables for the control circuit.	36
(f)	PU connector	Connects the operation panel (FR-DU08) or the parameter unit (FR-PU07). This connector also enables the RS-485 communication.	51
(g)	USB A connector	Connects a USB memory device.	54
(h)	USB mini B connector	Connects a personal computer and enables communication with FR Configurator2.	54
(i)	Upper front cover	Remove this cover for the installation of the product, installation of a plug-in (communication) option, RS-485 terminal wiring, switching of the voltage/current input switch, etc.	15
(j)	Power lamp	Stays ON while the power is supplied to the control circuit (R1/L11, S1/L21).	31
(k)	Alarm lamp	Turns ON when the protective function of the inverter is activated.	87
(l)	Charge lamp	Stays ON while the power is supplied to the main circuit.	31
(m)	Operation panel (FR-DU08)	Operates and monitors the inverter.	*1
(n)	Lower front cover	Remove this cover for wiring.	15
(o)	Main circuit terminal block	Connects cables for the main circuit.	30
(p)	Cooling fan	Cools the inverter.	98
(q)	CC-Link IE Field Network communication connector	For an Ethernet cable which connects to the network.	53
(r)	Operation status indication LED	Indicates the CC-Link IE Field Network communication status.	10

1

About the related manuals

Symbol	Name	Description	Refer to page
(s)	Switches for manufacturer setting (SW3)	Do not change the initial setting (OFF  ON).	—

*1 Refer to the FR-A800 Instruction Manual (Detailed)

◆ Operation status LEDs

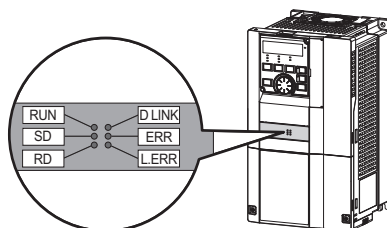

1.3 About the related manuals

The manuals related to FR-A800 are shown below.

Manual name	Manual number
FR-A800 Instruction Manual (Detailed)	IB-0600503ENG
FR-CC2 Instruction Manual	IB-0600543ENG
FR Configurator2 Instruction Manual	IB-0600516ENG
FR-A800/F800 PLC Function Programming Manual	IB-0600492ENG
FR-A800/F800 Safety stop function instruction manual	BCN-A23228-001

2 **INSTALLATION AND WIRING**

This chapter explains the "installation" and the "wiring" of this product.

Always read the instructions before using the equipment.

2.1	Peripheral devices	12
2.2	Removal and reinstallation of the operation panel or the front covers	15
2.3	Installation and enclosure design	17
2.4	Terminal connection diagrams	26
2.5	Main circuit terminals	30
2.6	Control circuit	36
2.7	Communication connectors and terminals	51
2.8	Connection of motor with encoder (vector control)	56
2.9	Parameter settings for a motor with encoder	62
2.10	Connection of stand-alone option units	63

2.1 Peripheral devices

2.1.1 Inverter and peripheral devices

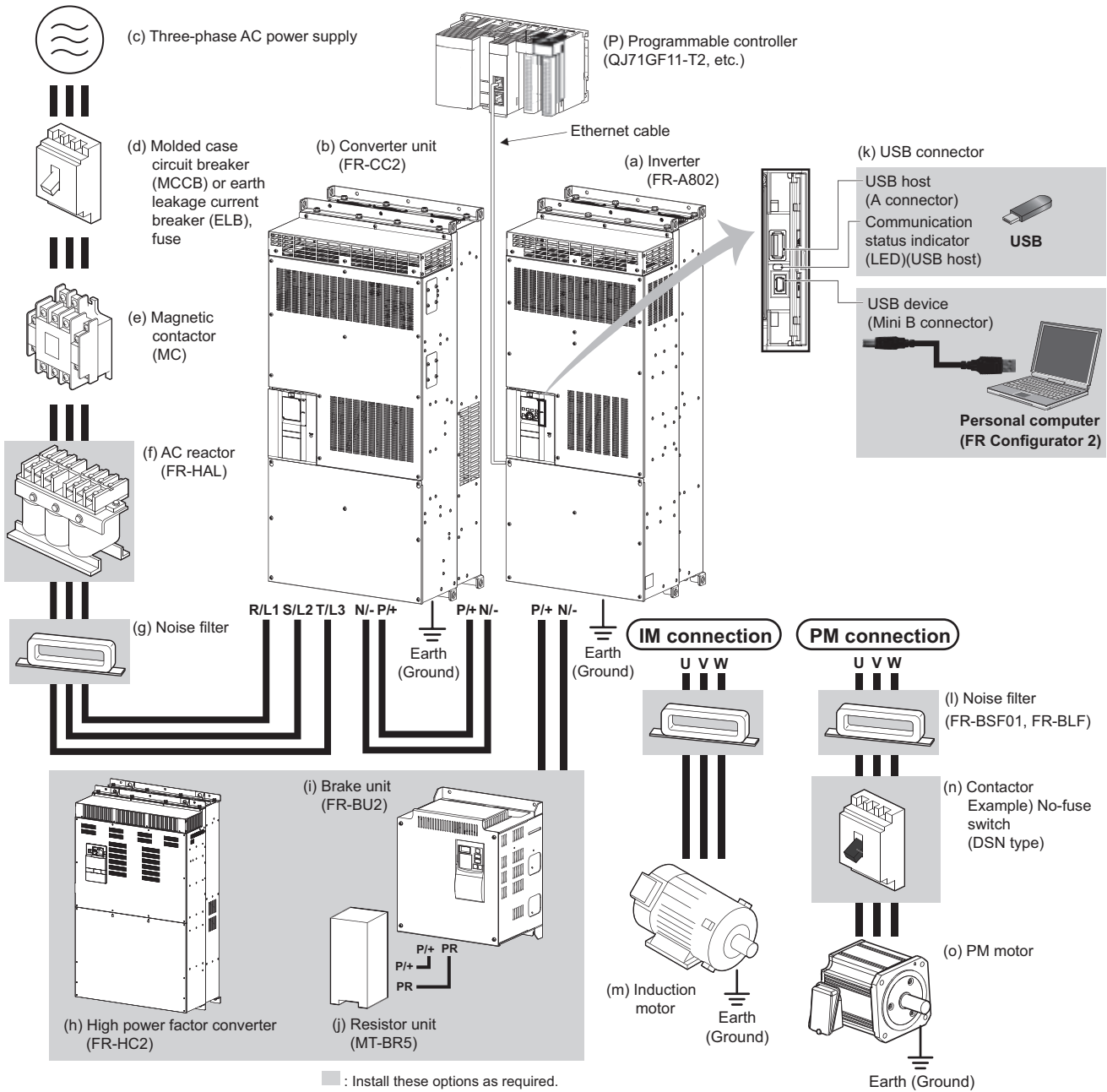

NOTE

- To prevent an electric shock, always earth (ground) the motor, the inverter, and the converter unit.
- Do not install a power factor correction capacitor or surge suppressor or capacitor type filter on the inverter's output side. Doing so will cause the inverter to trip or the capacitor and surge suppressor to be damaged. If any of the above devices is connected, immediately remove it. When installing a molded case circuit breaker on the output side of the inverter, contact the manufacturer of the molded case circuit breaker.
- Electromagnetic wave interference
The input/output (main circuit) of the inverter or the converter unit includes high frequency components, which may interfere with the communication devices (such as AM radios) used near the inverter or the converter unit. In this case, activating the EMC filter of the converter unit may minimize interference. (Refer to [page 74.](#))
- For details of options and peripheral devices, refer to the respective Instruction Manual.
- A PM motor cannot be driven by the commercial power supply.
- A PM motor is a motor with permanent magnets embedded inside. High voltage is generated at the motor terminals while the motor is running. Before closing the contactor at the output side, make sure that the inverter power is ON and the motor is stopped.

Symbol	Name	Overview	Refer to page
(a)	Inverter (FR-A802)	The life of the inverter and the converter unit is influenced by the surrounding air temperature. The surrounding air temperature should be as low as possible within the permissible range. This must be noted especially when the inverter is installed in an enclosure.	17 26 74
(b)	Converter unit (FR-CC2)	Incorrect wiring may lead to damage of the inverter and the converter unit. The control signal lines must be kept fully away from the main circuit lines to protect them from noise. The converter unit built-in EMC filter can reduce the noise.	
(c)	Three-phase AC power supply	Must be within the permissible power supply specifications of the converter unit.	106
(d)	Molded case circuit breaker (MCCB), earth leakage circuit breaker (ELB), or fuse	Must be selected carefully since an inrush current flows in the converter unit at power ON.	14
(e)	Magnetic contactor (MC)	Install this to ensure safety. Do not use this to start and stop the inverter. Doing so will shorten the life of the inverter and the converter unit.	79
(f)	AC reactor (FR-HAL)	Install this to suppress harmonics and to improve the power factor. An AC reactor (FR-HAL) (option) is required when installing the inverter near a large power supply system (1000 kVA or more). Under such condition, the inverter and the converter unit may be damaged if you do not use a reactor. Select a reactor according to the applied motor capacity.	78
(g)	Noise filter	Suppresses the noise radiated from the power supply side of the converter unit.	71
(h)	High power factor converter (FR-HC2)	Suppresses the power supply harmonics significantly. Install these options as required. When FR-HC2 is used, FR-CC2 is not required.	64
(i)	Brake unit (FR-BU2)	Allows the inverter to provide the optimal regenerative braking capability. Install these options as required.	63
(j)	Resistor unit (MT-BR5)		
(k)	USB connection	A USB (Ver. 1.1) cable connects the inverter with a personal computer. A USB memory device enables parameter copies and the trace function.	54
(l)	Noise filter	Install this to reduce the electromagnetic noise generated from the inverter and the converter unit. The noise filter is effective in the range from about 0.5 MHz to 5 MHz.	71
(m)	Induction motor	Connect a squirrel-cage induction motor.	—
(n)	Contactor Example) No-fuse switch (DSN type)	Connect this for an application where a PM motor is driven by the load even while the inverter power is OFF. Do not open or close the contactor while the inverter is running (outputting).	—
(o)	PM motor	A PM motor can be used. A PM motor cannot be driven by the commercial power supply.	—
(p)	Programmable controller (QJ71GF11-T2, etc.)	Allows the inverter to be operated or monitored, or the parameter setting to be changed via the CC-Link IE Field Network.	—

2.1.2 Peripheral devices

◆ Selecting the converter unit (FR-CC2)

Select the capacity of the FR-CC2 converter unit according to the connected motor capacity.

Motor capacity (kW) *1	Converter unit FR-CC2-[]	Inverter												
		SLD (superlight duty)		LD (light duty)		ND (normal duty, initial value)		HD (heavy duty)						
		Model FR-A842-[]	Rated current (A)	Model FR-A842-[]	Rated current (A)	Model FR-A842-[]	Rated current (A)	Model FR-A842-[]	Rated current (A)					
280	H315	-	-	-	-	-	-	-	-	-	-	315K	07700	547
315	H315K	-	-	-	-	-	-	315K	07700	610	-	355K	08660	610
355	H355K	-	-	-	315K	07700	683	355K	08660	683	400K	09620	683	-
400	H400K	315K	07700	770	355K	08660	770	400K	09620	770	450K	10940	770	-
450	H450K	355K	08660	866	400K	09620	866	450K	10940	866	500K	12120	866	-
500	H500K	400K	09620	962	450K	10940	962	500K	12120	962	-	-	-	-
560	H560K	450K	10940	1094	500K	12120	1094	-	-	-	-	-	-	-
630	H630K	500K	12120	1212	-	-	-	-	-	-	-	-	-	-

*1 The motor capacity indicated is the maximum capacity applicable for use of the Mitsubishi Electric 4-pole standard motor.

◆ Selecting the breaker/magnetic contactor

Check the model of the inverter and the converter unit you purchased. Appropriate peripheral devices must be selected according to the capacity.

Refer to the table below to prepare appropriate peripheral devices.

- 400 V class

Motor output (kW)	Applicable converter model*1	Molded case circuit breaker (MCCB)*1*2 or earth leakage circuit breaker (ELB) (NF, NV type)	Input-side magnetic contactor*1*3
315	FR-CC2-H315K	700 A	S-N600
355	FR-CC2-H355K	800 A	S-N600
400	FR-CC2-H400K	900 A	S-N800
450	FR-CC2-H450K	1000 A	1000 A rated product
500	FR-CC2-H500K	1200 A	1000 A rated product
560	FR-CC2-H560K	1500 A	1200 rated product
630	FR-CC2-H630K	2000 A	1400 rated product

*1 Assumes the use of a Mitsubishi Electric 4-pole standard motor with the power supply voltage of 400 VAC 50 Hz.

*2 Select an MCCB according to the power supply capacity.

Install one MCCB per converter.

(For the use in the United States or Canada, refer to [page 118](#), and select the appropriate fuse.)

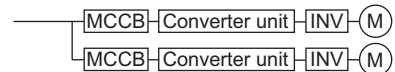

*3 The magnetic contactor is selected based on the AC-1 class. The electrical durability of magnetic contactor is 500,000 times. When the magnetic contactor is used for emergency stops during motor driving, the electrical durability is 25 times.

If using an MC for emergency stop during driving the motor, select an MC regarding the converter unit input side current as JEM 1038-AC-3 class rated current. When using an MC on the inverter output side for commercial-power supply operation switching using a general-purpose motor, select an MC regarding the rated motor current as JEM 1038-AC-3 class rated current.

NOTE

- When the converter unit capacity is larger than the motor capacity, select an MCCB and a magnetic contactor according to the converter unit model, and select cables and reactors according to the motor output.
- When the breaker on the converter unit's input side trips, check for the wiring fault (short circuit), damage to internal parts of the inverter and the converter unit, etc. The cause of the trip must be identified and removed before turning ON the power of the breaker.

2.2 Removal and reinstallation of the operation panel or the front covers

◆ Removal and reinstallation of the operation panel

- Loosen the two screws on the operation panel.
(These screws cannot be removed.)
- Push the upper part of the operation panel and pull the operation panel to remove.

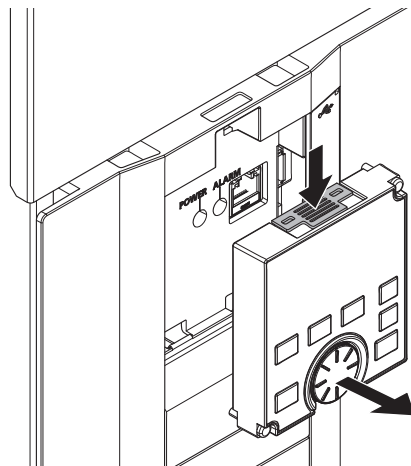
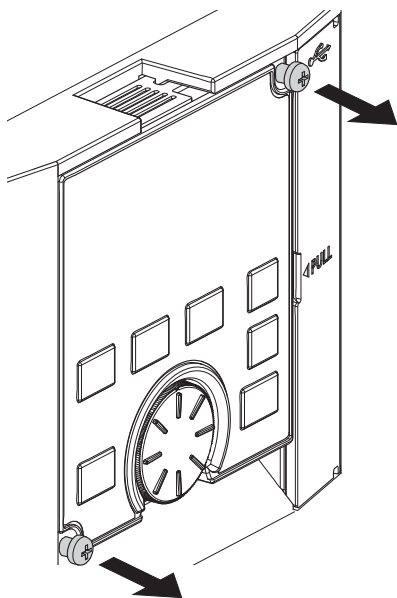

To reinstall the operation panel, align its connector on the back with the PU connector of the inverter, and insert the operation panel. After confirming that the operation panel is fit securely, tighten the screws. (Tightening torque: 0.40 to 0.45 N·m)

◆ Removal of the lower front cover

(a)

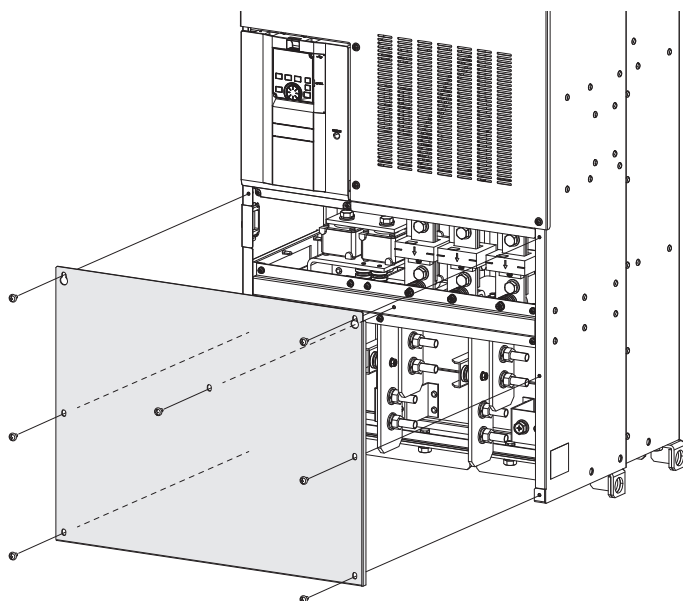

(b)

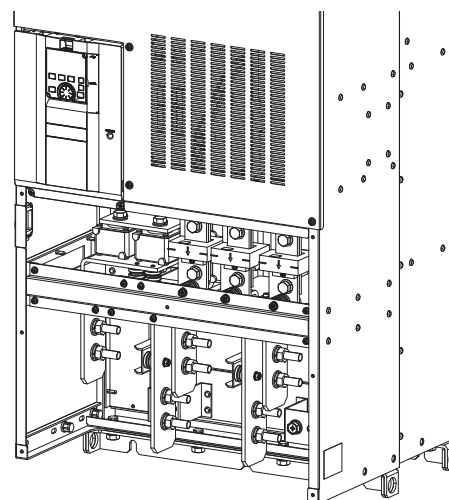

- (a) When the mounting screws are removed, the lower front cover can be removed. (The number of the mounting screws differs by the capacity.)
- (b) With the lower front cover removed, the main circuit terminals can be wired.

◆ Removal of the upper front cover

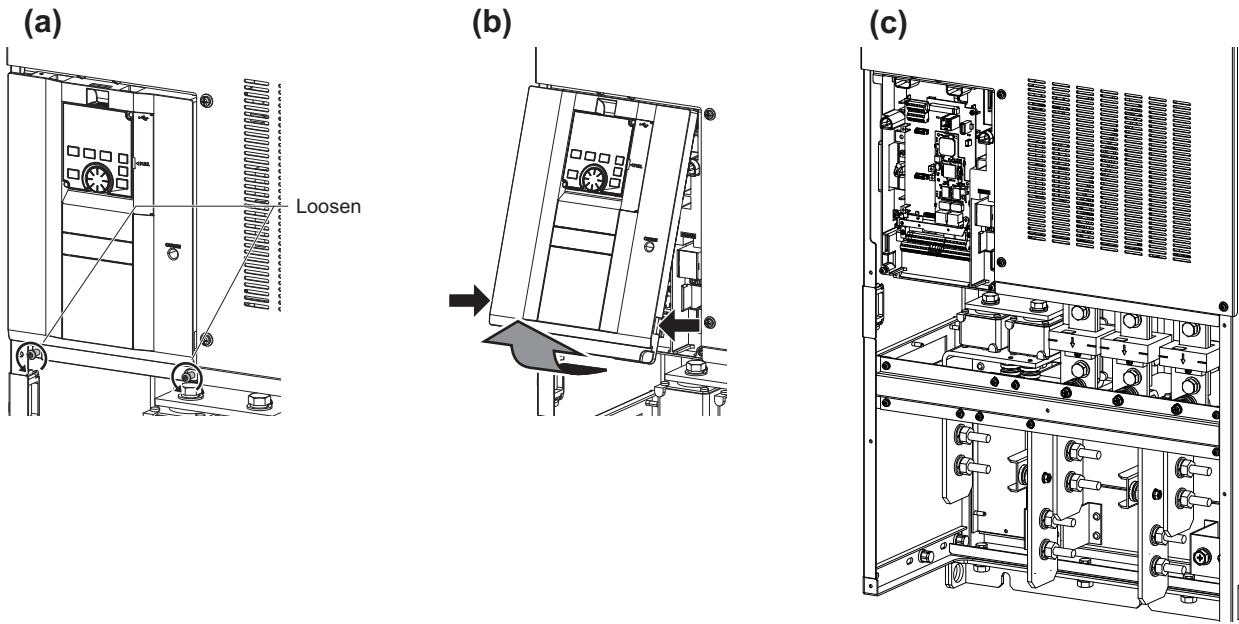

- (a) With the lower front cover removed, loosen the mounting screws on the upper front cover. (These screws cannot be removed.)
- (b) While holding the areas around the installation hooks on the sides of the upper front cover, pull out the cover using its upper side as a support.
- (c) With the upper front cover removed, the control circuit can be wired and the plug-in option can be installed.

◆ Reinstallation of the front cover

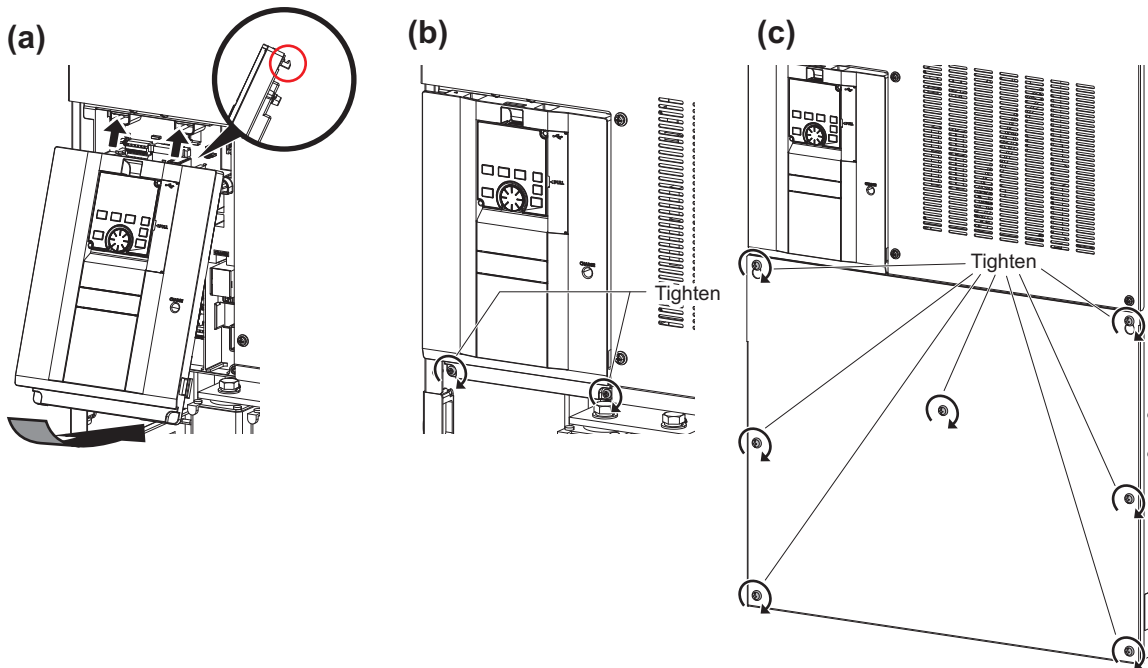

- (a) Clip on the upper front cover as illustrated. Check that it is properly secured.
- (b) Tighten the screws on the lower part of the upper front cover.
- (c) Attach the lower front cover using the screws. The number of screws differs depending on the capacity of the inverter.

NOTE

- When installing the upper front cover, fit the connector of the operation panel securely along the guides of the PU connector.
- Fully make sure that the front cover has been reinstalled securely. Always tighten the installation screws of the front cover.

2.3 Installation and enclosure design

When designing or manufacturing an inverter enclosure, determine the structure, size, and device layout of the enclosure by fully considering the conditions such as heat generation of the contained devices and the operating environment. An inverter uses many semiconductor devices. To ensure higher reliability and long period of operation, operate the inverter in the ambient environment that completely satisfies the equipment specifications.

2.3.1 Inverter installation environment

The following table lists the standard specifications of the inverter installation environment. Using the inverter in an environment that does not satisfy the conditions deteriorates the performance, shortens the life, and causes a failure. Refer to the following points, and take adequate measures.

◆ Standard environmental specifications of the inverter

Item		Description
Surrounding air temperature	LD, ND (initial setting), HD	0 to +50°C (non-freezing)
	SLD	0 to +40°C (non-freezing)
Surrounding air humidity		With circuit board coating (conforming to class 3C2/3S2 in IEC 60721-3-3): 95% RH or less (non-condensing) Without circuit board coating 90% RH or less (non-condensing)
Storage temperature		-20 to +65°C*1
Atmosphere		Indoors (free from corrosive gas, flammable gas, oil mist, dust and dirt)
Altitude		Maximum 2500 m*2
Vibration		2.9 m/s ² or less at 10 to 55 Hz (directions of X, Y, Z axes)

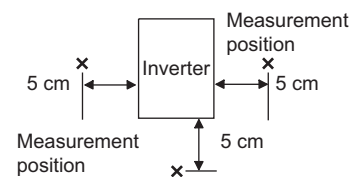

*1 Temperature applicable for a short time, e.g. in transit.

*2 For installation at an altitude above 1000 m, consider a 3% reduction in the rated current per 500 m increase in altitude.

◆ Temperature

The permissible surrounding air temperature of the inverter is between 0°C and +50°C (0°C and +40°C at the SLD rating). Always operate the inverter within this temperature range. Operation outside this range will considerably shorten the service lives of the semiconductors, parts, capacitors and others. Take the following measures to keep the surrounding air temperature of the inverter within the specified range.

(a) Measures against high temperature

- Use a forced ventilation system or similar cooling system. (Refer to [page 21](#).)
- Install the enclosure in an air-conditioned electric chamber.
- Block direct sunlight.
- Provide a shield or similar plate to avoid direct exposure to the radiated heat and wind of a heat source.
- Ventilate the area around the enclosure well.

(b) Measures against low temperature

- Provide a space heater in the enclosure.
- Do not power OFF the inverter. (Keep the start signal of the inverter OFF.)

(c) Sudden temperature changes

- Select an installation place where temperature does not change suddenly.
- Avoid installing the inverter near the air outlet of an air conditioner.
- If temperature changes are caused by opening/closing of a door, install the inverter away from the door.



- For the amount of heat generated by the inverter unit, refer to [page 20](#).

◆ Humidity

Operate the inverter within the ambient air humidity of usually 45 to 90% (up to 95% with circuit board coating). Too high humidity will pose problems of reduced insulation and metal corrosion. On the other hand, too low humidity may cause a spatial electrical breakdown. The insulation distance defined in JEM 1103 "Control Equipment Insulator" is humidity of 45 to 85%.

(a) Measures against high humidity

- Make the enclosure enclosed, and provide it with a hygroscopic agent.
- Provide dry air into the enclosure from outside.
- Provide a space heater in the enclosure.

(b) Measures against low humidity

Air with proper humidity can be blown into the enclosure from outside. Also when installing or inspecting the unit, discharge your body (static electricity) beforehand, and keep your body away from the parts and patterns.

(c) Measures against condensation

Condensation may occur if frequent operation stops change the in-enclosure temperature suddenly or if the outside air temperature changes suddenly.

Condensation causes such faults as reduced insulation and corrosion.

- Take the measures against high humidity in (a).
- Do not power OFF the inverter. (Keep the start signal of the inverter OFF.)

◆ Dust, dirt, oil mist

Dust and dirt will cause such faults as poor contacts, reduced insulation and cooling effect due to the moisture-absorbed accumulated dust and dirt, and in-enclosure temperature rise due to a clogged filter. In an atmosphere where conductive powder floats, dust and dirt will cause such faults as malfunction, deteriorated insulation and short circuit in a short time. Since oil mist will cause similar conditions, it is necessary to take adequate measures.

Countermeasure

- Place the inverter in a totally enclosed enclosure.
Take measures if the in-enclosure temperature rises. (Refer to [page 21](#).)
- Purge air.
Pump clean air from outside to make the in-enclosure air pressure higher than the outside air pressure.

◆ Corrosive gas, salt damage

If the inverter is exposed to corrosive gas or to salt near a beach, the printed board patterns and parts will corrode or the relays and switches will result in poor contact.

In such places, take the measures given above.

◆ Explosive, flammable gases

As the inverter is non-explosion proof, it must be contained in an explosion-proof enclosure. In places where explosion may be caused by explosive gas, dust or dirt, an enclosure cannot be used unless it structurally complies with the guidelines and has passed the specified tests. This makes the enclosure itself expensive (including the test charges). The best way is to avoid installation in such places and install the inverter in a non-hazardous place.

◆ High altitude

Use the inverter at an altitude of within 2500 m. For use at an altitude above 1000 m, consider a 3% reduction in the rated current per 500 m increase in altitude.

If it is used at a higher place, it is likely that thin air will reduce the cooling effect and low air pressure will deteriorate dielectric strength.

◆ Vibration, impact

The vibration resistance of the inverter is up to 2.9 m/s^2 at 10 to 55 Hz frequency and 1 mm amplitude for the directions of X, Y, Z axes. Applying vibration and impacts for a long time may loosen the structures and cause poor contacts of connectors, even if those vibration and impacts are within the specified values.

Especially when impacts are applied repeatedly, caution must be taken because such impacts may break the installation feet.

Countermeasure

- Provide the enclosure with rubber vibration isolators.
- Strengthen the structure to prevent the enclosure from resonance.
- Install the enclosure away from the sources of the vibration.

2.3.2 Amount of heat generated by the inverter

◆ Installing the heat sink inside the enclosure

When the heat sink is installed inside the enclosure, the amount of heat generated by the inverter unit and converter unit is shown in the following tables.

Converter FR-CC2-H[]	Amount of heat generated (W)
315K	2350
355K	2600
400K	3050
450K	3400
500K	3800
560K	4400
630K	4920

Inverter FR-A842-[]	Amount of heat generated (W)			
	SLD	LD	ND	HD
315K	5800	5050	4450	3900
355K	6690	5800	5100	4410
400K	7370	6480	5650	4930
450K	8600	7340	6500	5650
500K	9810	8630	7400	6490

NOTE

- The amount of heat generated shown assumes that the output current is the inverter rated current, and the carrier frequency is 2 kHz.

◆ Installing the heat sink outside the enclosure

When the heat sink is protruded through a panel, the amount of heat generated by the inverter unit and converter unit is shown in the following tables. (For the details on protruding the heat sink through a panel, refer to [page 24](#).)

Converter FR-CC2-H[]	Amount of heat generated (W)	
	Heat sink section (outside of enclosure)	Control section (inside of enclosure)
315K	1640	710
355K	1820	780
400K	2130	920
450K	2380	1020
500K	2660	1140
560K	3080	1320
630K	3440	1480

Inverter FR-A842-[]	Amount of heat generated (W)							
	Heat sink section (outside of enclosure)				Control section (inside of enclosure)			
	SLD	LD	ND	HD	SLD	LD	ND	HD
315K	4060	3530	3110	2730	1740	1520	1340	1170
355K	4680	4060	3570	3080	2010	1740	1530	1330
400K	5160	4530	3950	3450	2210	1950	1700	1480
450K	6020	5140	4550	3950	2580	2200	1950	1700
500K	6860	6040	5180	4540	2950	2590	2220	1950

NOTE

- The amount of heat generated shown assumes that the output current is the inverter rated current, and the carrier frequency is 2 kHz.

2.3.3 Cooling system types for inverter enclosure

From the enclosure that contains the inverter, the heat of the inverter and other equipment (transformers, lamps, resistors, etc.) and the incoming heat such as direct sunlight must be dissipated to keep the in-enclosure temperature lower than the permissible temperatures of the in-enclosure equipment including the inverter.

The cooling systems are classified as follows in terms of the cooling calculation method.

- (a) Cooling by natural heat dissipation from the enclosure surface (totally enclosed type)
- (b) Cooling by heat sink (aluminum fin, etc.)
- (c) Cooling by ventilation (forced ventilation type, pipe ventilation type)
- (d) Cooling by heat exchanger or cooler (heat pipe, cooler, etc.)

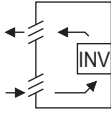
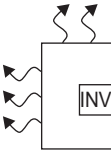
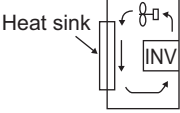
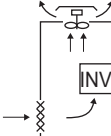
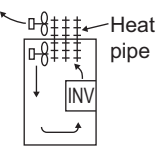
Cooling system		Enclosure structure	Comment
Natural cooling	Natural ventilation (enclosed, open type)		This system is low in cost and generally used, but the enclosure size increases as the inverter capacity increases. This system is for relatively small capacities.
	Natural ventilation (totally enclosed type)		Being a totally enclosed type, this system is the most appropriate for hostile environment having dust, dirt, oil mist, etc. The enclosure size increases depending on the inverter capacity.
Forced cooling	Heat sink cooling		This system has restrictions on the heat sink mounting position and area. This system is for relatively small capacities.
	Forced ventilation		This system is for general indoor installation. This is appropriate for enclosure downsizing and cost reduction, and often used.
	Heat pipe		This is a totally enclosed for enclosure downsizing.

2.3.4 Inverter installation

◆ Inverter placement

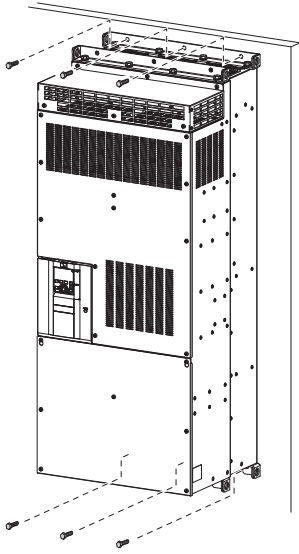

- Install the inverter on a strong surface securely with screws.
- Leave enough clearances and take cooling measures.
- Avoid places where the inverter is subjected to direct sunlight, high temperature and high humidity.
- Install the inverter on a nonflammable wall surface.
- When encasing multiple inverters in an enclosure, install them in parallel as a cooling measure.
- For heat dissipation and maintenance, keep clearance between the inverter and the other devices or enclosure surface. The clearance below the inverter is required as a wiring space, and the clearance above the inverter is required as a heat dissipation space.
- When designing or building an enclosure for the inverter, carefully consider influencing factors such as heat generation of the contained devices and the operating environment.

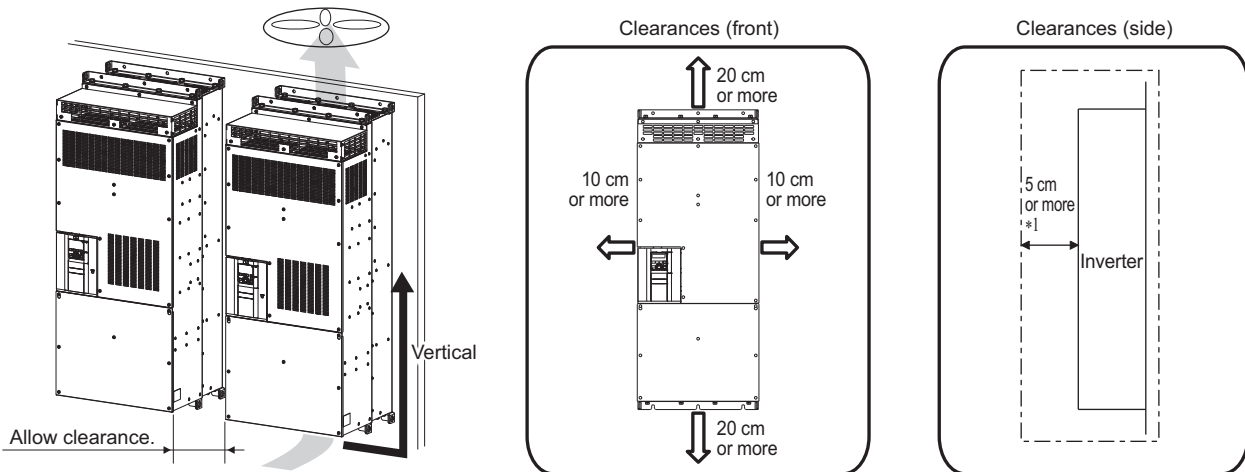

◆ Installation orientation of the inverter

Install the inverter on a wall as specified. Do not mount it horizontally or in any other way.

◆ Above the inverter

Heat is blown up from inside the inverter by the small fan built in the unit. Any equipment placed above the inverter should be heat resistant.

◆ Encasing multiple inverters and converter units

When multiple inverters and converter units are placed in the same enclosure, arrange them horizontally as shown in the figure on the right.

Do not place multiple products vertically. The exhaust air temperature of the inverter and the converter unit may be increased.

When mounting multiple inverters and converter units, fully take caution not to make the surrounding air temperature of the inverter and the converter unit higher than the permissible value by providing ventilation and increasing the enclosure size.

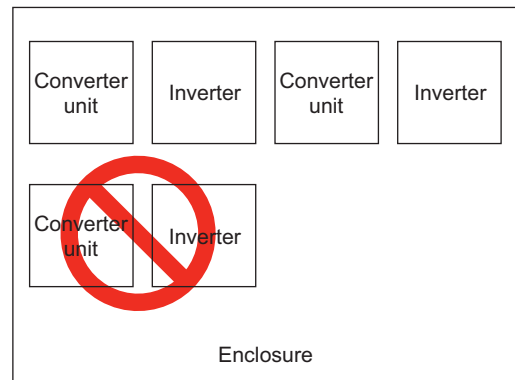

Arrangement of multiple inverters and converter units

◆ Arrangement of the ventilation fan and inverter

Heat generated in the inverter is blown up from the bottom of the unit as warm air by the cooling fan. When installing a ventilation fan for that heat, determine the place of ventilation fan installation after fully considering an air flow. (Air passes through areas of low resistance. Make an airway and airflow plates to expose the inverter to cool air.)

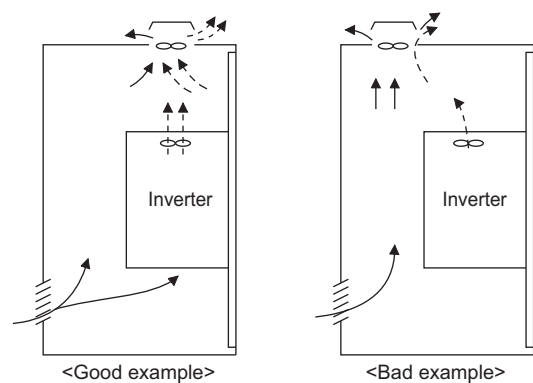

Arrangement of the ventilation fan and inverter

2.3.5 Protruding the heat sink through the panel

When encasing an inverter to an enclosure, the heat generated in the enclosure can be greatly reduced by protruding the heat sink of the inverter through the panel.

When installing the inverter in a compact enclosure, etc., this installation method is recommended.

◆ Panel cutting

Cut the panel of the enclosure according to the inverter capacity.

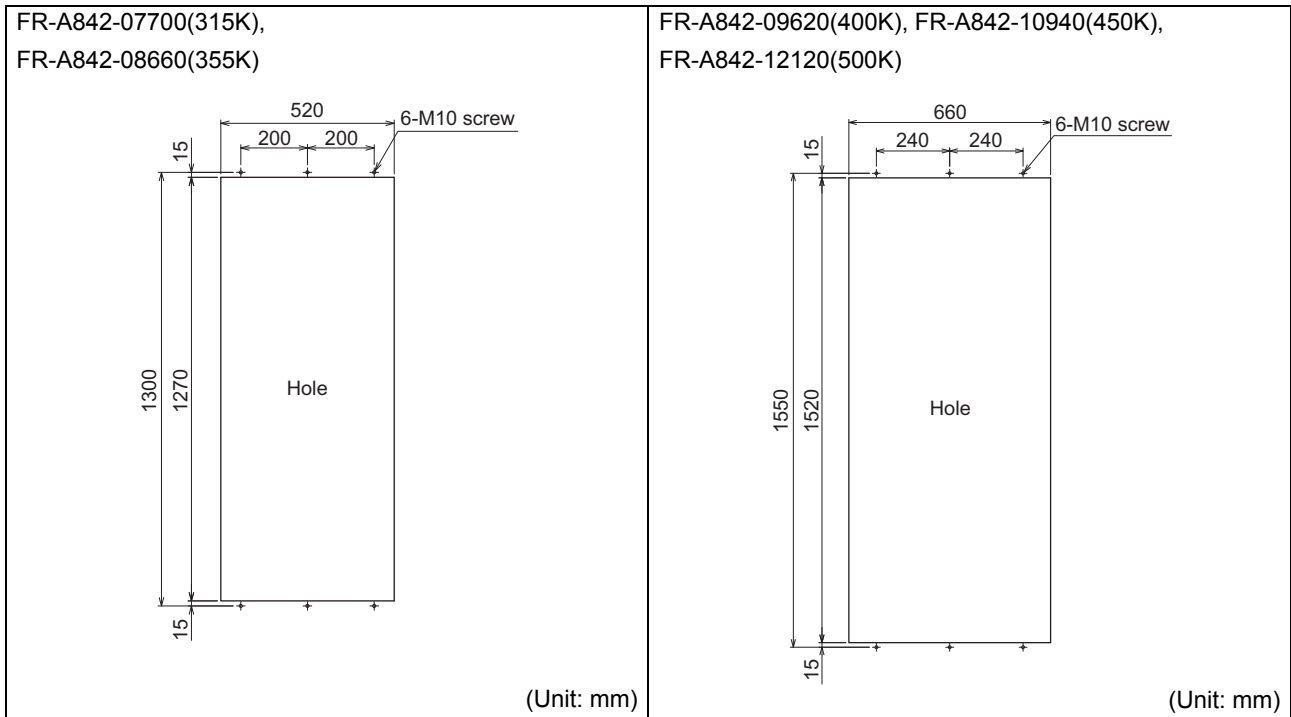

◆ Removal of the rear installation frame

Two installation frames are attached to each of the upper and lower parts of the inverter. Remove the rear side installation frame on the top and bottom of the inverter as shown on the right.

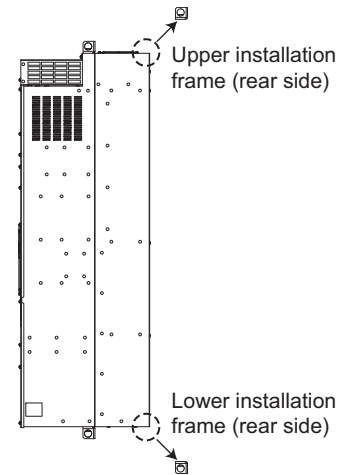

◆ Installation of the inverter

Push the inverter heat sink portion outside the enclosure and fix the enclosure and inverter with upper and lower installation frame.

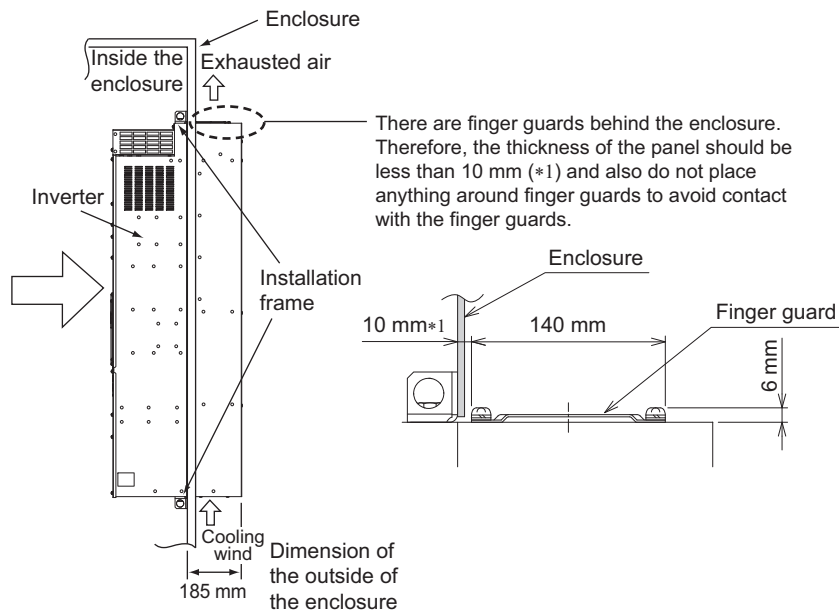

NOTE

- Having a cooling fan, the cooling section which comes out of the enclosure cannot be used in the environment of water drops, oil, mist, dust, etc.
- Be careful not to drop screws, dust etc. into the inverter and cooling fan section.

2.4 Terminal connection diagrams

◆FM type

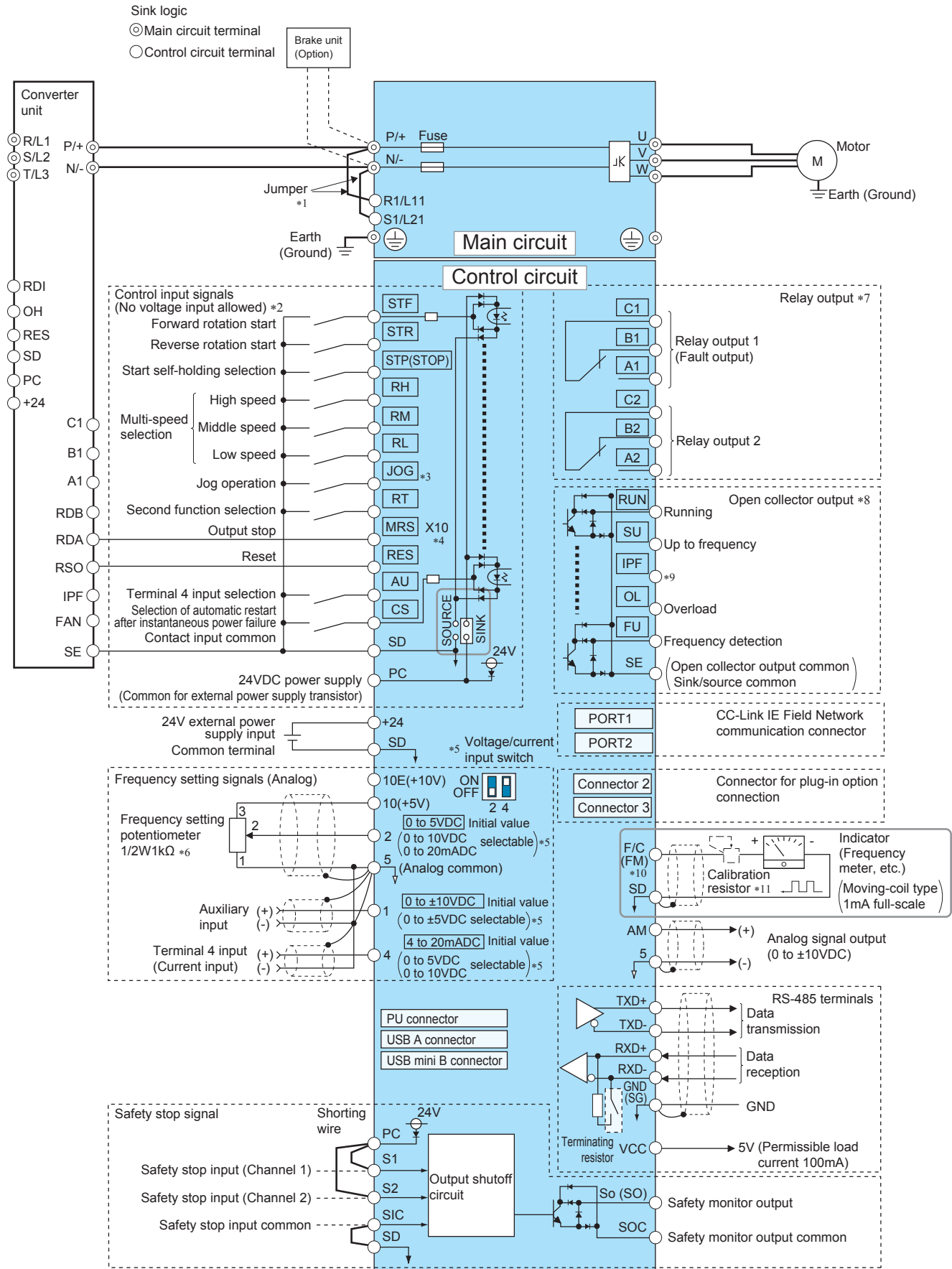

- *1 The terminals R1/L11 and S1/L21 are connected to the terminals P/+ and N/- with a jumper respectively. When using separate power supply for the control circuit, remove the jumpers from R1/L11 and S1/L21.
- *2 The function of these terminals can be changed with the input terminal assignment (**Pr.178 to Pr.189**).
- *3 Terminal JOG is also used as the pulse train input terminal. Use **Pr.291** to choose JOG or pulse.
- *4 The X10 signal (NC contact input specification) is assigned to the terminal MRS in the initial setting. Set **Pr.599** = "0" to change the input specification of the X10 signal to NO contact.
- *5 Terminal input specifications can be changed by analog input specification switchover (**Pr.73, Pr.267**). To input a voltage (0 to 5 V/0 to 10 V), set the voltage/current input switch OFF. To input a current (4 to 20 mA), set the voltage/current input switch ON. Terminals 10 and 2 are also used as a PTC input terminal. (**Pr.561**)
- *6 It is recommended to use 2 W 1 k Ω when the frequency setting signal is changed frequently.
- *7 The function of these terminals can be changed with the output terminal assignment (**Pr.195, Pr.196**).
- *8 The function of these terminals can be changed with the output terminal assignment (**Pr.190 to Pr.194**).
- *9 No function is assigned in the initial setting. Use **Pr.192** for function assignment.
- *10 The terminal FM can be used to output pulse trains as open collector output by setting **Pr.291**.
- *11 Not required when calibrating the scale with the operation panel.

NOTE

- To prevent a malfunction due to noise, keep the signal cables 10 cm or more away from the power cables. Also, separate the main circuit cables at the input side from the main circuit cables at the output side.
- After wiring, wire offcuts must not be left in the inverter.
Wire offcuts can cause an alarm, failure or malfunction. Always keep the inverter clean.
When drilling mounting holes in an enclosure etc., take caution not to allow chips and other foreign matter to enter the inverter.
- Set the voltage/current input switch correctly. Incorrect setting may cause a fault, failure or malfunction.

◆ CA type

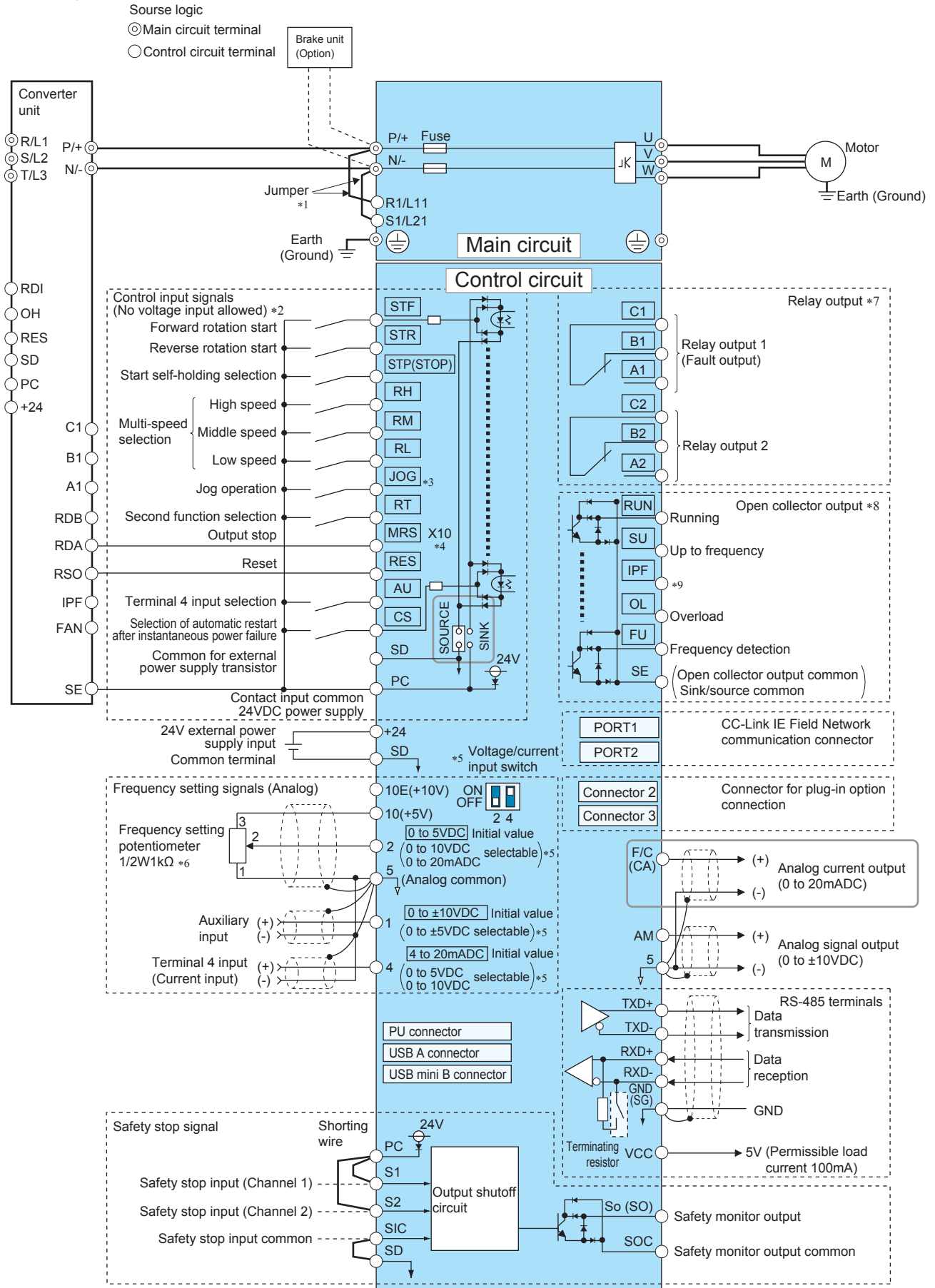

- *1 The terminals R1/L11 and S1/L21 are connected to the terminals P/+ and N/- with a jumper respectively. When using separate power supply for the control circuit, remove the jumpers from R1/L11 and S1/L21.
- *2 The function of these terminals can be changed with the input terminal assignment (Pr.178 to Pr.189).
- *3 Terminal JOG is also used as the pulse train input terminal. Use Pr.291 to choose JOG or pulse.
- *4 The X10 signal (NC contact input specification) is assigned to the terminal MRS in the initial setting. Set Pr.599 = "0" to change the input specification of the X10 signal to NO contact.
- *5 Terminal input specifications can be changed by analog input specification switchover (Pr.73, Pr.267). To input a voltage (0 to 5 V/0 to 10 V), set the voltage/current input switch OFF. To input a current (4 to 20 mA), set the voltage/current input switch ON. Terminals 10 and 2 are also used as a PTC input terminal. (Pr.561)
- *6 It is recommended to use 2 W 1 kΩ when the frequency setting signal is changed frequently.
- *7 The function of these terminals can be changed with the output terminal assignment (Pr.195, Pr.196).
- *8 The function of these terminals can be changed with the output terminal assignment (Pr.190 to Pr.194).
- *9 No function is assigned in the initial setting. Use Pr.192 for function assignment.

NOTE

- To prevent a malfunction due to noise, keep the signal cables 10 cm or more away from the power cables. Also, separate the main circuit cables at the input side from the main circuit cables at the output side.
- After wiring, wire offcuts must not be left in the inverter.
Wire offcuts can cause an alarm, failure or malfunction. Always keep the inverter clean.
When drilling mounting holes in an enclosure etc., take caution not to allow chips and other foreign matter to enter the inverter.
- Set the voltage/current input switch correctly. Incorrect setting may cause a fault, failure or malfunction.

◆ Connection between the converter unit and the inverter

Perform wiring so that the commands sent from the converter unit are transmitted to the inverter without fail. Incorrect connection may damage the converter unit and the inverter.

For the wiring length, refer to the table below.

Total wiring length	Across the terminals P and P and the terminals N and N	50 m or lower
	Other control signal cables	30 m or lower

For the cable gauge of the cable across the main circuit terminals P/+ and N/- (P and P, N and N), refer to [page 32](#).

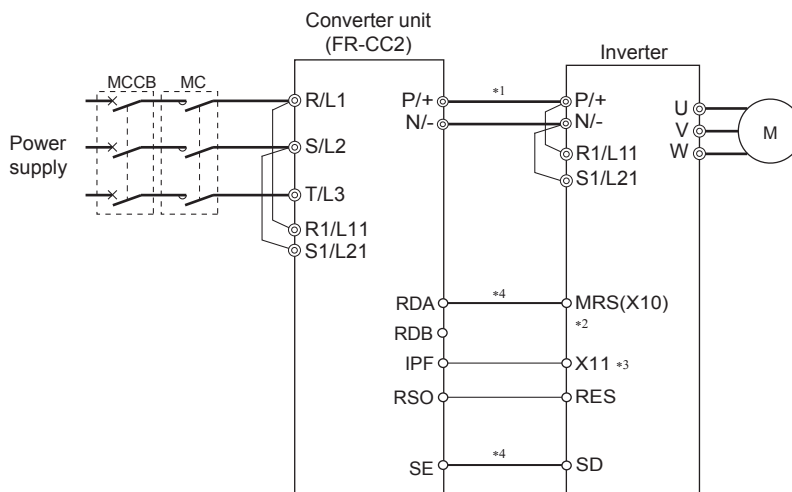

- *1 Do not install an MCCB across the terminals P/+ and N/- (across terminals P and P/+ or across N and N/-). Connecting the opposite polarity of terminals N/- and P/+ will damage the inverter.
- *2 For the terminal used for the X10 signal input, set "10" in any of Pr.178 to Pr.189 (input terminal function selection) to assign the function. (The X10 signal is assigned to the terminal MRS in the initial setting.)
For the X10 signal, NC contact input specification is selected in the initial setting. Set Pr.599 = "0" to change the input specification to NO contact.
- *3 For the terminal used for the X11 signal input, set "11" in any of Pr.178 to Pr.189 (input terminal function selection) to assign the function. For RS-485 or any other communication where the start command is only transmitted once, use the X11 signal to save the operation mode at the time of an instantaneous power failure.
- *4 Always connect the terminal RDA of the converter unit and the terminal MRS (X10) of the inverter, and the terminal SE of the converter unit and the terminal SD (sink logic) of the inverter. Not connecting these terminals may damage the converter unit.

2.5 Main circuit terminals

2.5.1 Details on the main circuit terminals of the inverter

Terminal symbol	Terminal name	Terminal function description	Refer to page
U, V, W	Inverter output	Connect these terminals to a three-phase squirrel cage motor or a PM motor.	-
R1/L11, S1/L21	Power supply for the control circuit	Connected to the terminals P/+ and N/-. To retain the fault display and fault output, or to use the converter unit (FR-CC2), remove the jumpers installed in terminals R1/L11 and S1/L21, and apply external power supply to these terminals. The power capacity necessary when separate power is supplied from R1/L11 and S1/L21 is 80 VA.	46
P/+, N/-	Converter unit connection	Connect the converter unit (FR-CC2), brake unit (FR-BU2), or high power factor converter (FR-HC2).	26, 63
	Earth (ground)	For earthing (grounding) the inverter chassis. This must be earthed (grounded).	35

2.5.2 Details on the main circuit terminals of the converter unit (FR-CC2)

Terminal symbol	Terminal name	Terminal function description	Refer to page
R/L1, S/L2, T/L3	AC power input	Connect these terminals to the commercial power supply. (When the converter unit is connected to the 12-phase rectifier power transformer, refer to the Instruction Manual of the FR-CC2.)	-
R1/L11, S1/L21	Power supply for the control circuit	Connected to the AC power supply terminals R/L1 and S/L2. To retain the fault display and fault output, remove the jumpers across terminals R/L1 and R1/L11 and across S/L2 and S1/L21, and supply external power to these terminals. The power capacity necessary when separate power is supplied from R1/L11 and S1/L21 is 80 VA.	46
P/+, N/-	Inverter connection	Connect to terminals P/+ and N/- of the inverter.	26
	Earth (ground)	For earthing (grounding) the converter unit chassis. This must be earthed (grounded).	35

2.5.3 Terminal layout of the main circuit terminals, wiring of power supply and the motor

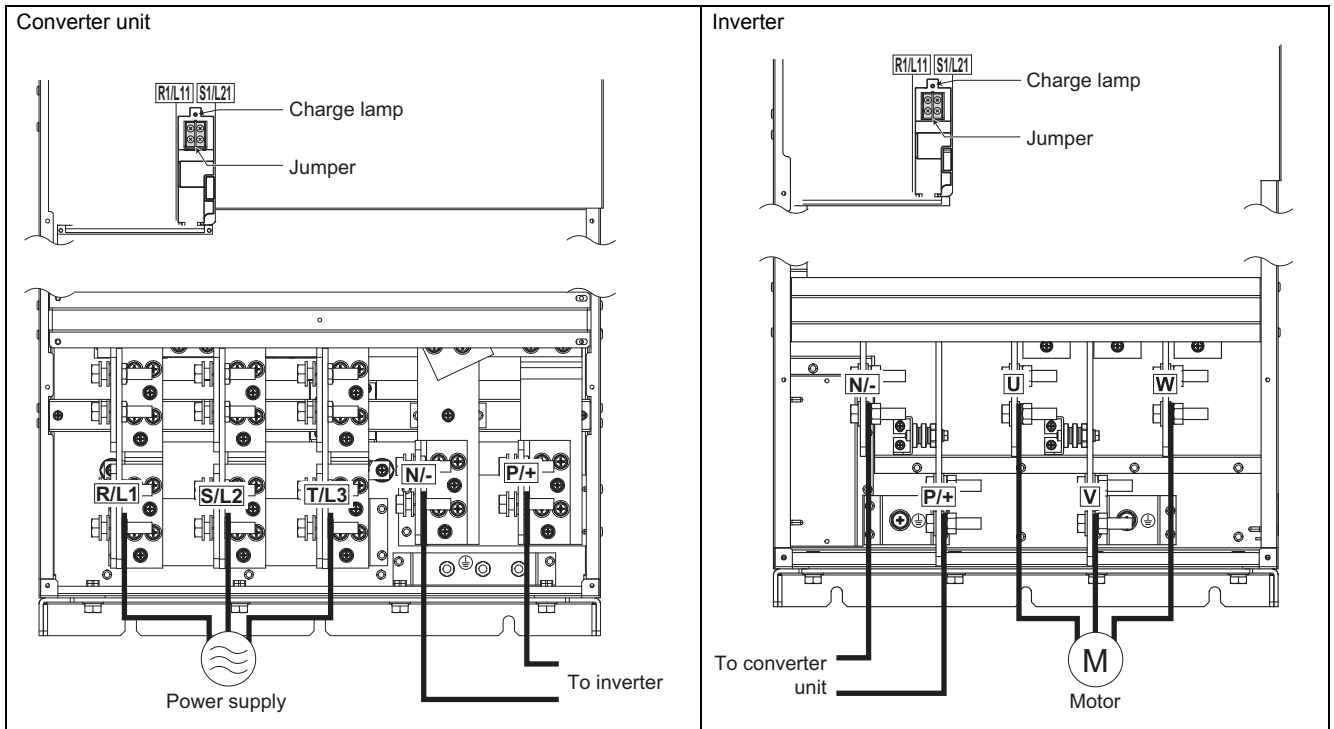

NOTE

- Make sure the power cables are connected to the R/L1, S/L2, and T/L3 of the converter unit. (Phase need not be matched.) Never connect the power cable to the U, V, and W of the inverter. Doing so will damage the inverter.
- Connect the motor to the U, V, and W of the inverter. (The phases must be matched.)
- When wiring the main circuit conductor, tighten a nut from the right side of the conductor. When wiring two wires, place wires on both sides of the conductor. (Refer to the diagram below.) For wiring, use bolts (nuts) provided with the inverter.

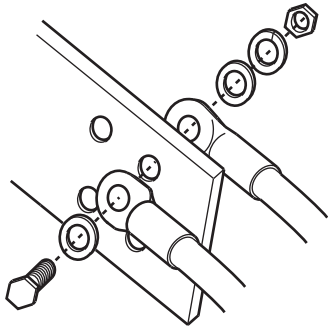

- When wiring the main circuit conductor (R/L1, S/L2, T/L3) of the converter unit (FR-CC2), use the bolts (nuts) for main circuit wiring, which are provided on the front side of the conductor.

FR-CC2-H315K, H355K

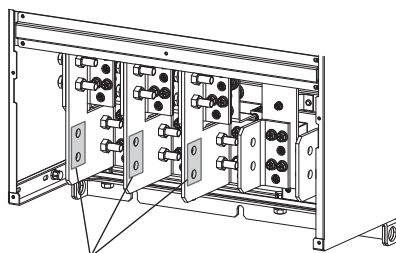

Connect the cables here.

FR-CC2-H400K to H500K

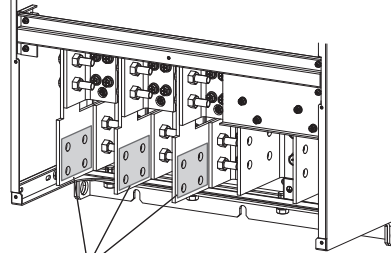

Connect the cables here.

2.5.4 Applicable cables and wiring length

Select a recommended cable size to ensure that the voltage drop will be 2% or less.

If the wiring distance is long between the inverter and motor, the voltage drop in the main circuit will cause the motor torque to decrease especially at a low speed.

The following table indicates a selection example for the wiring length of 20 m (440 V input power supply).

- Converter unit (FR-CC2)

Converter model FR-CC2-H[]	Terminal screw Size*4	Tightening Torque N·m	Crimping terminal	Cable gauge					
				HIV cables, etc. (mm ²)*1			AWG/MCM *2	PVC cables, etc. (mm ²)*3	
				R/L1, S/L2, T/L3	R/L1, S/L2, T/L3	P/+, N/-	Earthing (grounding) cable	R/L1, S/L2, T/L3	R/L1, S/L2, T/L3
315K	M12 (M10)	46	150-12	2×150	2×150	100	2×300	2×150	150
355K	M12 (M10)	46	C2-200	2×200	2×200	100	2×350	2×185	2×95
400K	M12 (M10)	46	C2-200	2×200	2×200	100	2×400	2×185	2×95
450K	M12 (M10)	46	C2-250	2×250	2×250	100	2×500	2×240	2×120
500K	M12 (M10)	46	C2-200	3×200	3×200	2×100	2×500	2×240	2×120
560K	M12 (M10)	46	C2-200	3×200	3×200	2×100	3×350	3×185	2×150
630K	M12 (M10)	46	C2-200	3×200	3×200	2×100	3×400	3×185	2×150

- Inverter (ND rating)

Inverter model FR-A842-[]	Terminal screw size*4	Tightening Torque N·m	Crimping terminal	Cable gauge					
				HIV cables, etc. (mm ²)*1			AWG/MCM*2	PVC cables, etc. (mm ²)*3	
				U, V, W	U, V, W	P/+, N/-	Earthing (grounding) cable	U, V, W	U, V, W
07700(315K)	M12 (M10)	46	150-12	2×150	2×150	100	2×300	2×150	150
08660(355K)	M12 (M10)	46	C2-200	2×200	2×200	100	2×350	2×185	2×95
09620(400K)	M12 (M10)	46	C2-200	2×200	2×200	100	2×400	2×185	2×95
10940(450K)	M12 (M10)	46	C2-250	2×250	2×250	100	2×500	2×240	2×120
12120(500K)	M12 (M10)	46	C2-250	2×250	3×200	2×100	2×500	2×240	2×120

- Inverter (SLD rating)

Inverter model FR-A842-[]	Terminal screw size*4	Tightening Torque N·m	Crimping terminal	Cable gauge					
				HIV cables, etc. (mm ²)*1			AWG/MCM*2	PVC cables, etc. (mm ²)*3	
				U, V, W	U, V, W	P/+, N/-	Earthing (grounding) cable	U, V, W	U, V, W
07700(315K)	M12 (M10)	46	C2-200	2×200	2×200	100	2×400	2×185	2×95
08660(355K)	M12 (M10)	46	C2-250	2×250	2×250	100	2×500	2×240	2×120
09620(400K)	M12 (M10)	46	C2-250	2×250	3×200	2×100	2×500	2×240	2×120
10940(450K)	M12 (M10)	46	C2-200	3×200	3×200	2×100	3×350	3×185	2×150
12120(500K)	M12 (M10)	46	C2-200	3×200	3×200	2×100	3×400	3×185	2×150

• Inverter (LD rating)

Inverter model FR-A842-[]	Terminal screw size*4	Tightening Torque N·m	Crimp terminal	Cable gauge					
				HIV cables, etc. (mm ²)*1			AWG/MCM*2	PVC cables, etc. (mm ²)*3	
				U, V, W	U, V, W	P/+, N/-	Earthing (grounding) cable	U, V, W	U, V, W
07700(315K)	M12 (M10)	46	C2-200	2×200	2×200	100	2×350	2×185	2×95
08660(355K)	M12 (M10)	46	C2-200	2×200	2×200	100	2×400	2×185	2×95
09620(400K)	M12 (M10)	46	C2-250	2×250	2×250	100	2×500	2×240	2×120
10940(450K)	M12 (M10)	46	C2-250	2×250	3×200	2×100	2×500	2×240	2×120
12120(500K)	M12 (M10)	46	C2-200	3×200	3×200	2×100	3×350	3×185	2×150

• Inverter (HD rating)

Inverter model FR-A842-[]	Terminal screw size*4	Tightening Torque N·m	Crimp terminal	Cable gauge					
				HIV cables, etc. (mm ²)*1			AWG/MCM*2	PVC cables, etc. (mm ²)*3	
				U, V, W	U, V, W	P/+, N/-	Earthing (grounding) cable	U, V, W	U, V, W
07700(315K)	M12 (M10)	46	150-12	2×125	2×150	100	2×250	2×120	150
08660(355K)	M12 (M10)	46	150-12	2×150	2×150	100	2×300	2×150	150
09620(400K)	M12 (M10)	46	C2-200	2×200	2×200	100	2×350	2×185	2×95
10940(450K)	M12 (M10)	46	C2-200	2×200	2×200	100	2×400	2×185	2×95
12120(500K)	M12 (M10)	46	C2-250	2×250	2×250	100	2×500	2×240	2×120

*1 The gauge of the cable with the continuous maximum permissible temperature of 90°C or higher. (LMFC (heat resistant flexible cross-linked polyethylene insulated cable), etc.). It assumes a surrounding air temperature of 40°C or lower and in-enclosure wiring.

*2 The recommended cable size is that of the cable (THHN cable) with continuous maximum permissible temperature of 90°C. It assumes a surrounding air temperature of 40°C or lower and in-enclosure wiring.

(For the use in the United States or Canada, refer to [page 118](#).)

*3 The cable size is that of the cable (XLPE cable) with continuous maximum permissible temperature of 90°C. It assumes a surrounding air temperature of 40°C or lower and in-enclosure wiring.

(Selection example for use mainly in Europe.)

*4 The terminal screw size indicates the size of a terminal screw for R/L1, S/L2, T/L3, U, V, W, P/+, N/-, and a screw for earthing (grounding). Screw size for earthing (grounding) is indicated in parentheses.

The line voltage drop can be calculated by the following formula:

$$\text{Line voltage drop [V]} = \frac{\sqrt{3} \times \text{wire resistance [m}\Omega\text{/m]} \times \text{wiring distance [m]} \times \text{current [A]}}{1000}$$

Use a larger diameter cable when the wiring distance is long or when it is desired to decrease the voltage drop (torque reduction) in the low speed range.

 **NOTE**

- Tighten the terminal screw to the specified torque.
A screw that has been tightened too loosely can cause a short circuit or malfunction.
A screw that has been tightened too tightly can cause a short circuit or malfunction due to the unit breakage.
- Use crimping terminals with insulation sleeves to wire the power supply and motor.

◆ Total wiring length

◆ With induction motor

Connect one or more general-purpose motors within the total wiring length 500 m. (The wiring length should be 100 m or less under vector control.)

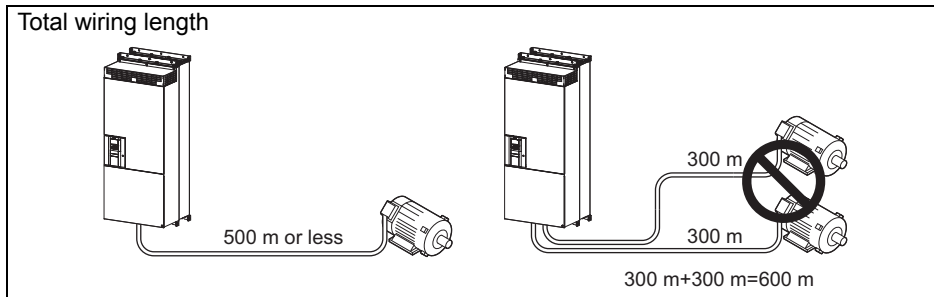

When driving a 400 V class motor by the inverter, surge voltages attributable to the wiring constants may occur at the motor terminals, deteriorating the insulation of the motor. In this case, take one of the following measure.

- Use a "400 V class inverter-driven insulation-enhanced motor" and set **Pr.72 PWM frequency selection** according to the wiring length.

Wiring length 100 m or shorter	Wiring length longer than 100 m
6 (6 kHz) or lower	4 (4 kHz) or lower

- If the motor capacity is 280 kW or lower, connect the sine wave filter (MT-BSL/BSC) to the output side.

◆ With PM motor

Use the wiring length of 100 m or shorter when connecting a PM motor.

Use one PM motor for one inverter. Multiple PM motors cannot be connected to an inverter.

When the wiring length exceeds 50 m for a 400 V class motor driven by an inverter under PM sensorless vector control, set "9" (6 kHz) or less in **Pr.72 PWM frequency selection**.

NOTE

- Especially for long-distance wiring, the inverter may be affected by a charging current caused by the stray capacitances of the wiring, leading to a malfunction of the overcurrent protective function or fast response current limit function or a malfunction or fault of the equipment connected on the inverter output side. If the fast-response current limit function malfunctions, disable this function. (For the details of **Pr.156 Stall prevention operation selection**, refer to the FR-A800 Instruction Manual (Detailed))
- A sine wave filter (MT-BSL/BSC) can be used under V/F control. Do not use the filters under different control methods.
- For the details of **Pr.72 PWM frequency selection**, refer to the Instruction Manual (Detailed).
- Refer to [page 80](#) to drive a 400 V class motor by an inverter.
- The carrier frequency is limited during PM sensorless vector control. (Refer to the Instruction Manual (Detailed))

2.5.5 Earthing (grounding) precautions

- Always earth (ground) the motor, the inverter, and the converter unit.

◆ Purpose of earthing (grounding)

Generally, an electrical apparatus has an earth (ground) terminal, which must be connected to the ground before use. An electrical circuit is usually insulated by an insulating material and encased. However, it is impossible to manufacture an insulating material that can shut off a leakage current completely, and actually, a slight current flows into the case. The purpose of earthing (grounding) the case of an electrical apparatus is to prevent operators from getting an electric shock from this leakage current when touching it.

To avoid the influence of external noises, this earthing (grounding) is important to audio equipment, sensors, computers and other apparatuses that handle low-level signals or operate very fast.

◆ Earthing (grounding) methods and earthing (grounding) work

As described previously, earthing (grounding) is roughly classified into an electrical shock prevention type and a noise-influenced malfunction prevention type. Therefore, these two types should be clearly distinguished, and the following work must be done to prevent the leakage current having the inverter's high frequency components from entering the malfunction prevention type earthing (grounding):

- Whenever possible, use the independent earthing (grounding) for the inverter.

If independent earthing (grounding) (I) is not available, use (II) common earthing (grounding) in the figure below where the inverter is connected with the other equipment at an earthing (grounding) point. Do not use the other equipment's earthing (grounding) cable to earth (ground) the inverter as shown in (III).

A leakage current containing many high frequency components flows into the earthing (grounding) cables of the inverter and peripheral devices. Because of this, the inverter must be earthed (grounded) separately from EMI-sensitive devices.

In a high building, it may be effective to use the EMI prevention type earthing (grounding) connecting to an iron structure frame, and electric shock prevention type earthing (grounding) with the independent earthing (grounding) together.

- Earthing (Grounding) must conform to the requirements of national and local safety regulations and electrical codes. (NEC section 250, IEC 61140 class 1 and other applicable standards).

A neutral-point earthed (grounded) power supply in compliance with EN standard must be used.

- use the thickest possible earthing (grounding) cable. The earthing (grounding) cable should be the size indicated in the table on [page 32](#).
- The earthing (grounding) point should be as close as possible to the inverter, and the earth (ground) wire length should be as short as possible.
- Run the earthing (grounding) cable as far away as possible from the I/O wiring of equipment sensitive to noises and run them in parallel in the minimum distance.

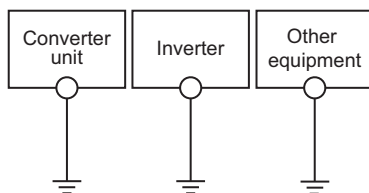

(I) Independent earthing (grounding).....Good

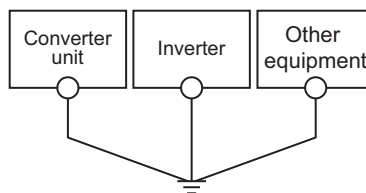

(II) Common earthing (grounding).....Good

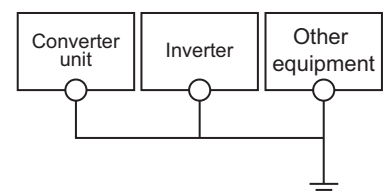

(III) Common earthing (grounding) cable.....Not allowed

NOTE

- To be compliant with the EU Directive (Low Voltage Directive), refer to [page 115](#).

2.6 Control circuit

2.6.1 Details on the control circuit terminals of the inverter

The input signal function of the terminals in can be selected by setting **Pr.178 to Pr.196 (I/O terminal function selection)**.

For the parameter details, refer to the FR-A800 Instruction Manual (Detailed).

◆ Input signal

Type	Terminal symbol	Terminal name	Terminal function description		Rated specification
Contact input	STF	Forward rotation start	Turn ON the STF signal to start forward rotation and turn it OFF to stop.	When the STF and STR signals are turned ON simultaneously, the stop command is given.	Input resistance 4.7 kΩ Voltage when contacts are open: 21 to 27 VDC When contacts are short-circuited: 4 to 6 mADC
	STR	Reverse rotation start	Turn ON the STR signal to start reverse rotation and turn it OFF to stop.		
	STOP	Start self-holding selection	Turn ON the STOP signal to self-hold the start signal.		
	RH RM RL	Multi-speed selection	Multi-speed can be selected according to the combination of RH, RM and RL signals.		
	JOG	Jog mode selection	Turn ON the JOG signal to enable JOG operation (initial setting) and turn ON the start signal (STF or STR) to start JOG operation.		
		Pulse train input	Terminal JOG is also used as the pulse train input terminal. To use as a pulse train input terminal, change the Pr.291 setting. (maximum input pulse: 100k pulses/s)		
	RT	Second function selection	Turn ON the RT signal to enable the second function. When the second function such as "second torque boost" and "second V/F (base frequency)" is set, turning ON the RT signal enables the selected function.		
	MRS (X10)	Output stop (Inverter run enable)	Connect to the terminal RDA of the converter unit (FR-CC2). When the RDA signal is turned OFF, the inverter output is shut off. The X10 signal (NC contact) is assigned to the terminal MRS in the initial setting. Use Pr.599 to change the specification to NO contact.		
	RES	Reset	Use this signal to reset a fault output provided when a protective function is activated. Turn ON the RES signal for 0.1s or longer, then turn it OFF. In the initial setting, reset is always enabled. By setting Pr.75 , reset can be enabled only at an inverter fault occurrence. The inverter recovers about 1s after the reset is released.		
	AU	Terminal 4 input selection	The terminal 4 function is available only when the AU signal is ON. Turning ON the AU signal disables the terminal 2 function.		
	CS	Selection of automatic restart after instantaneous power failure	When the CS signal is left ON, the inverter restarts automatically at power restoration. Note that restart setting is necessary on both the inverter and the converter unit for this operation.		
	SD	Contact input common (sink)*2	Common terminal for contact input terminal (sink logic) and terminal FM		
		External transistor common (source)*3	Connect this terminal to the power supply common terminal of a transistor output (open collector output) device, such as a programmable controller, in the source logic to avoid malfunction by undesirable current.		
		24 VDC power supply common	Common terminal for the 24 VDC power supply (terminal PC, terminal +24) Isolated from terminals 5 and SE.		
PC	External transistor common (sink)*2	Connect this terminal to the power supply common terminal of a transistor output (open collector output) device, such as a programmable controller, in the source logic to avoid malfunction by undesirable current.			
	Contact input common (source)*3	Common terminal for contact input terminal (source logic).			
	24 VDC power supply common	Can be used as a 24 VDC 0.1 A power supply.			

Type	Terminal symbol	Terminal name	Terminal function description	Rated specification
Frequency setting	10E	Frequency setting power supply	When connecting the frequency setting potentiometer at an initial status, connect it to the terminal 10. Change the input specifications of the terminal 2 in Pr.73 when connecting it to the terminal 10E.	10 VDC ± 0.4 V Permissible load current 10 mA
	10			5 VDC ± 0.5 V Permissible load current 10 mA
	2	Frequency setting (voltage)	Inputting 0 to 5 VDC (or 0 to 10 V, 0 to 20 mA) provides the maximum output frequency at 5 V (10 V, 20 mA) and makes input and output proportional. Use Pr.73 to switch among input 0 to 5 VDC (initial setting), 0 to 10 VDC, and 0 to 20 mA. Set the voltage/current input switch in the ON position to select current input (0 to 20 mA).*1	When voltage is input: Input resistance 10 k Ω ± 1 k Ω Maximum permissible voltage 20 VDC
	4	Frequency setting (current)	Inputting 4 to 20 mADC (or 0 to 5 V, 0 to 10 V) provides the maximum output frequency at 20 mA and makes input and output proportional. This input signal is valid only when the AU signal is ON (terminal 2 input is invalid). Use Pr.267 to switch among input 4 to 20 mA (initial setting), 0 to 5 VDC, and 0 to 10 VDC. Set the voltage/current input switch in the OFF position to select voltage input (0 to 5 V/0 to 10 V).*1 Use Pr.858 to switch terminal functions.	When current is input: Input resistance 245 Ω ± 5 Ω Permissible maximum current 30 mA
	1	Frequency setting auxiliary	Inputting 0 to ± 5 VDC or 0 to ± 10 VDC adds this signal to terminal 2 or 4 frequency setting signal. Use Pr.73 to switch between input 0 to ± 5 VDC and 0 to ± 10 VDC (initial setting). Use Pr.868 to switch terminal functions.	Input resistance 10 k Ω ± 1 k Ω Permissible maximum voltage ± 20 VDC
	5	Frequency setting common	Common terminal for frequency setting signal (terminal 2, 1 or 4) and analog output terminal AM. Do not earth (ground).	—
Thermistor	10 2	PTC thermistor input	For receiving PTC thermistor outputs. When PTC thermistor is valid (Pr.561 \neq "9999"), the terminal 2 is not available for frequency setting.	Applicable PTC thermistor specification Overheat detection resistance: 0.5 to 30 k Ω (Set by Pr.561)
Power supply input	+24	24 V external power supply input	For connecting a 24 V external power supply. If a 24 V external power supply is connected, power is supplied to the control circuit while the main power circuit is OFF.	Input voltage 23 to 25.5 VDC Input current 1.4 A or less

*1 Set **Pr.73**, **Pr.267**, and the voltage/current input switch correctly, then input an analog signal in accordance with the setting. Applying a voltage with the voltage/current input switch ON (current input is selected) or a current with the switch OFF (voltage input is selected) could cause component damage of the inverter or analog circuits of output devices. (For the details, refer to the FR-A800 Instruction Manual (Detailed).)

*2 The sink logic is initially set for the FM-type inverter.

*3 The source logic is initially set for the CA-type inverter.

◆ Output signal

Type	Terminal symbol	Terminal name	Terminal function description	Rated specification
Relay	A1, B1, C1	Relay output 1 (fault output)	1 changeover contact output that indicates that an inverter's protective function has been activated and the outputs are stopped. Fault: discontinuity across B and C (continuity across A and C), Normal: continuity across B and C (discontinuity across A and C)	Contact capacity 230 VAC 0.3 A (power factor = 0.4) 30 VDC 0.3 A
	A2, B2, C2	Relay output 2	1 changeover contact output	

Control circuit

Type	Terminal symbol	Terminal name	Terminal function description	Rated specification
Open collector	RUN	Inverter running	Switched to LOW when the inverter output frequency is equal to or higher than the starting frequency (initial value 0.5 Hz). Switched to HIGH during stop or DC injection brake operation.	Permissible load 24 VDC (maximum 27 VDC) 0.1 A (The voltage drop is 2.8 V at maximum while the signal is ON.) LOW is when the open collector output transistor is ON (conducted). HIGH is when the transistor is OFF (not conducted).
	SU	Up to frequency	Switched to LOW when the output frequency is within the set frequency range $\pm 10\%$ (initial value). Switched to HIGH during acceleration/ deceleration and at a stop.	
	OL	Overload alarm	Switched to LOW when stall prevention is activated by the stall prevention function. Switched to HIGH when stall prevention is canceled.	
	IPF	Open collector output	No function is assigned in the initial setting. The function can be assigned setting Pr.192 .	
	FU	Frequency detection	Switched to LOW when the inverter output frequency is equal to or higher than the preset detection frequency, and to HIGH when it is less than the preset detection frequency.	
	SE	Open collector output common	Common terminal for terminals RUN, SU, OL, IPF, FU	
Pulse	FM *1	For meter	Outputs a selected monitored item (such as output frequency) among several monitored items. The signal is not output during an inverter reset.	Output item: Output frequency (initial setting)
		NPN open collector output		This terminal can be used for open collector outputs by setting Pr.291 .
Analog	AM	Analog voltage output	The output signal is proportional to the magnitude of the corresponding monitoring item. Use Pr.55 , Pr.56 , and Pr.866 to set full scales for the monitored output frequency, output current, and torque.	Output item: Output frequency (initial setting)
	CA *2	Analog current output		Output signal 0 to 10 VDC, Permissible load current 1 mA (load impedance 10 k Ω or more) resolution 8 bits Load impedance 200 Ω to 450 Ω Output signal 0 to 20 mADC

*1 Terminal FM is provided in the FM-type inverter.

*2 Terminal CA is provided in the CA-type inverter.

◆ Communication

Type	Terminal symbol	Terminal name	Terminal function description	
CC-Link IE	—	PORT 1	Communication can be made via the CC-Link IE Field Network.	
		PORT 2		
RS-485	—	PU connector	With the PU connector, communication can be made through RS-485. (For connection on a 1:1 basis only) Conforming standard: EIA-485 (RS-485) Transmission format: Multidrop link Communication speed: 4800 to 115200 bps Wiring length: 500 m	
		RS-485 terminals	TXD+	The RS-485 terminals enable the communication by RS-485. Conforming standard: EIA-485 (RS-485) Transmission format: Multidrop link Communication speed: 300 to 115200 bps Overall length: 500 m
			TXD-	
			RXD+	
			RXD-	
GND (SG)	Earthing (grounding)			
USB	—	USB A connector	A connector (receptacle) A USB memory device enables parameter copies and the trace function.	Interface: Conforms to USB1.1 (USB2.0 fullspeed compatible) Transmission speed: 12 Mbps
		USB B connector	Mini B connector (receptacle) Connected to a personal computer via USB to enable setting, monitoring, test operations of the inverter by FR Configurator2.	

◆ Safety stop signal

For the safety stop function, refer to [page 49](#).

Terminal symbol	Terminal name	Terminal function description	Rated specification
S1	Safety stop input (Channel 1)	The terminals S1 and S2 are used for the safety stop input signal for the safety relay module. The terminals S1 and S2 are used at the same time (dual channel). Inverter output is shutoff by shortening/opening between terminals S1 and SIC, or between S2 and SIC. In the initial status, terminal S1 and S2 are shorted with the terminal PC by shorting wires. The terminal SIC is shorted with the terminal SD. Remove the shorting wires and connect the safety relay module when using the safety stop function.	Input resistance 4.7 kΩ Input current 4 to 6 mA DC (with 24 VDC input)
S2	Safety stop input (Channel 2)		
SIC	Safety stop input terminal common	Common terminal for terminals S1 and S2.	—
So (SO)	Safety monitor output Open collector output	Indicates the safety stop input signal status. Switched to LOW when the status is other than the internal safety circuit failure. Switched to HIGH during the internal safety circuit failure status. LOW is when the open collector output transistor is ON (conducted). HIGH is when the transistor is OFF (not conducted). Refer to the Safety stop function instruction manual (BCNA23228-001) when the signal is switched to HIGH while both terminals S1 and S2 are open. (Please contact your sales representative for the manual.)	Permissible load 24 VDC (27 VDC at maximum), 0.1 A (The voltage drop is 3.4 V at maximum while the signal is ON.)
SOC	Safety monitor output terminal common	Common terminal for terminal So (SO).	—

2.6.2 Details on the control circuit terminals of the converter unit (FR-CC2)

The input signal function of the terminals in  can be selected by setting **Pr.178, Pr.187, Pr.189 to Pr.195 (I/O terminal function selection)**.

For the parameter details, refer to the FR-CC2 Instruction Manual.

◆ Input signal

Type	Terminal symbol	Terminal name	Terminal function description	Rated specification
Contact input	RES	Reset	Use this signal to reset a fault output provided when a protective function is activated. Turn ON the RES signal for 0.1 s or longer, then turn it OFF. In the initial setting, reset is always enabled. By setting Pr.75 , reset can be set enabled only at fault occurrence of the converter unit. The inverter recovers about 1s after the reset is released.	Input resistance 4.7 kΩ Voltage when contacts are open: 21 to 27 VDC When contacts are short-circuited: 4 to 6 mADC
	OH	External thermal relay input	The external thermal relay input (OH) signal is used when using an external thermal relay or a thermal protector built into the motor to protect the motor from overheating. When the thermal relay is activated, the inverter trips by the external thermal relay operation (E.OHT).	
	RDI	Contact input	The function can be assigned by setting Pr.178 .	
	SD	Contact input common (sink)	Common terminal for contact input terminal (sink logic) and terminal FM	—
		External transistor common (source)	Connect this terminal to the power supply common terminal of a transistor output (open collector output) device, such as a programmable controller, in the source logic to avoid malfunction by undesirable current.	
		24 VDC power supply common	Common terminal for the 24 VDC power supply (terminal PC, terminal +24) Isolated from terminals 5 and SE.	
	PC	External transistor common (sink)	Connect this terminal to the power supply common terminal of a transistor output (open collector output) device, such as a programmable controller, in the source logic to avoid malfunction by undesirable current.	Power supply voltage range 19.2 to 28.8 VDC Permissible load current 100 mA
		Contact input common (source)	Common terminal for contact input terminal (source logic).	
		24 VDC power supply common	Can be used as a 24 VDC 0.1 A power supply.	
	Power supply input	+24	24 V external power supply input	For connecting a 24 V external power supply. If a 24 V external power supply is connected, power is supplied to the control circuit while the main power circuit is OFF.

◆ Output signal

Type	Terminal symbol	Terminal name	Terminal function description	Rated specification
Relay	A1, B1, C1	Relay output 1 (fault output)	1 changeover contact output that indicates that the protective function of the converter unit has been activated and the outputs are stopped. Fault: discontinuity across B and C (continuity across A and C), Normal: continuity across Band C (discontinuity across A and C)	Contact capacity 230 VAC 0.3 A (power factor = 0.4) 30 VDC 0.3 A
	88R, 88S	For manufacturer setting. Do not use.		
Open collector	RDA	Inverter operation enable (NO contact)	Switched to LOW when the converter unit operation is ready. Assign the signal to the terminal MRS (X10) of the inverter. The inverter can be started when the RDA status is LOW.	Permissible load 24 VDC (maximum 27 VDC) 0.1 A (The voltage drop is 2.8 V at maximum while the signal is ON.) LOW is when the open collector output transistor is ON (conducted). HIGH is when the transistor is OFF (not conducted).
	RDB	Inverter operation enable (NC contact)	Switched to LOW when a converter unit fault occurs or the converter is reset. The inverter can be started when the RDB status is HIGH.	
	RSO	Inverter reset	Switched to LOW when the converter is reset (RES-ON). Assign the signal to the terminal RES of the inverter. The inverter is reset when it is connected with the RSO status LOW.	
	IPF	Instantaneous power failure	Switched to LOW when an instantaneous power failure is detected.	
	FAN	Cooling fan fault	Switched to LOW when a cooling fan fault occurs.	
	SE	Open collector output common	Common terminal for terminals RDA, RDB, RSO, IPF, FAN Connect this terminal to the terminal SD (sink logic) or PC (source logic) of the inverter.	

! CAUTION

- Do not use the empty terminals (NC) of the control circuit. Doing so may lead to damage of the converter unit and the inverter.
- Always connect the terminal RDA of the converter unit and the terminal MRS (X10) of the inverter, and the terminal SE of the converter unit and the terminal SD (terminal PC in the source logic) of the inverter. Not doing so may lead to damage of the converter unit.

2.6.3 Control logic (sink/source) change

Change the control logic of input signals as necessary.

To change the control logic, change the jumper connector position on the control circuit board. Remove the control circuit terminal block and change the control logic. (Refer to [page 99](#) for details on how to remove the control circuit terminal block.)

Connect the jumper connector to the connector pin of the desired control logic.

The control logic of input signals is initially set to the sink logic (SINK) for the FM type inverter.

The control logic of input signals is initially set to the source logic (SOURCE) for the CA type inverter.

(The output signals may be used in either the sink or source logic independently of the jumper connector position.)

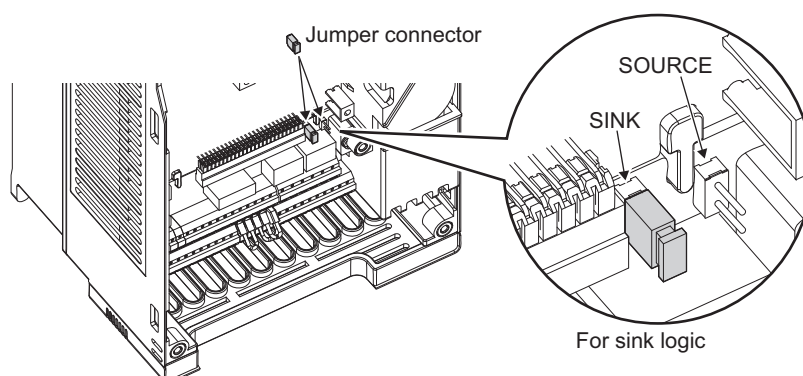

NOTE

- Make sure that the jumper connector is installed correctly.
- Never change the control logic while power is ON.
- After changing the jumper connector position, reinstall the control circuit terminal block securely in place.

◆ Sink logic and source logic

- In the sink logic, a signal switches ON when a current flows from the corresponding signal input terminal. Terminal SD is common to the contact input signals. Terminal SE is common to the open collector output signals.
- In the source logic, a signal switches ON when a current flows into the corresponding signal input terminal. Terminal PC is common to the contact input signals. Terminal SE is common to the open collector output signals.

● Current flow concerning the input/output signal when sink logic is selected

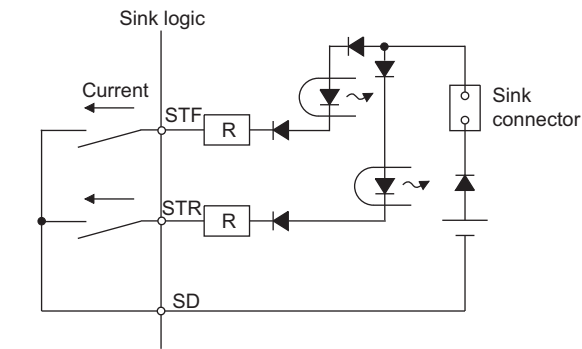

● Current flow concerning the input/output signal when source logic is selected

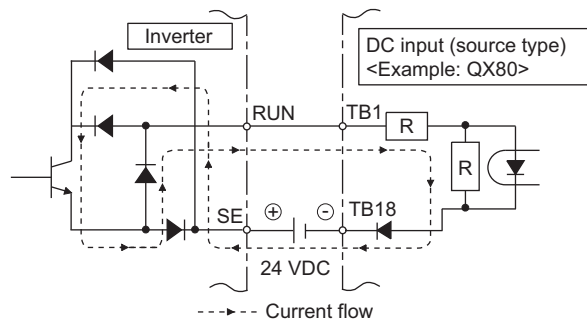
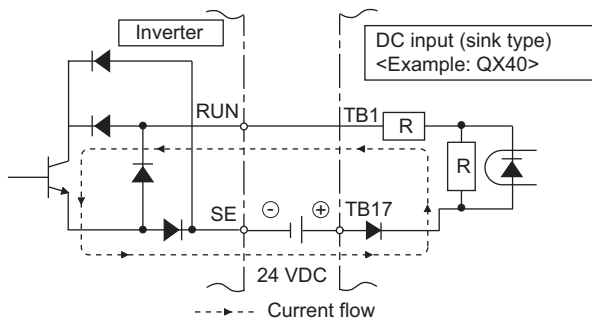
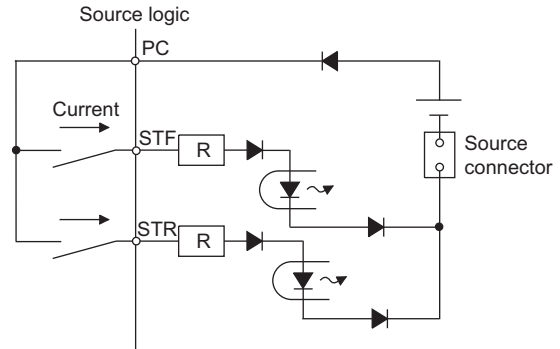

- When using an external power supply for transistor output

Sink logic

Use the terminal PC as a common terminal, and perform wiring as shown below. (Do not connect terminal SD of the inverter with the terminal 0 V of the external power supply. When using terminals PC-SD as a 24 VDC power supply, do not install an external power supply in parallel with the inverter. Doing so may cause a malfunction in the inverter due to undesirable currents.)

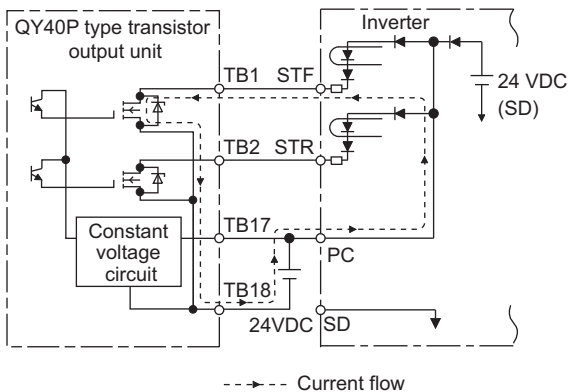

Source logic

Use the terminal SD as a common terminal, and perform wiring as shown below. (Do not connect terminal PC of the inverter with the terminal +24 V of the external power supply. When using terminals PC-SD as a 24 VDC power supply, do not install an external power supply in parallel with the inverter. Doing so may cause a malfunction in the inverter due to undesirable currents.)

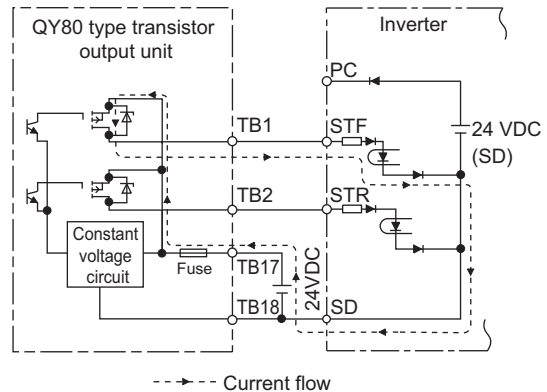

2.6.4 Wiring of inverter control circuit

◆ Control circuit terminal layout

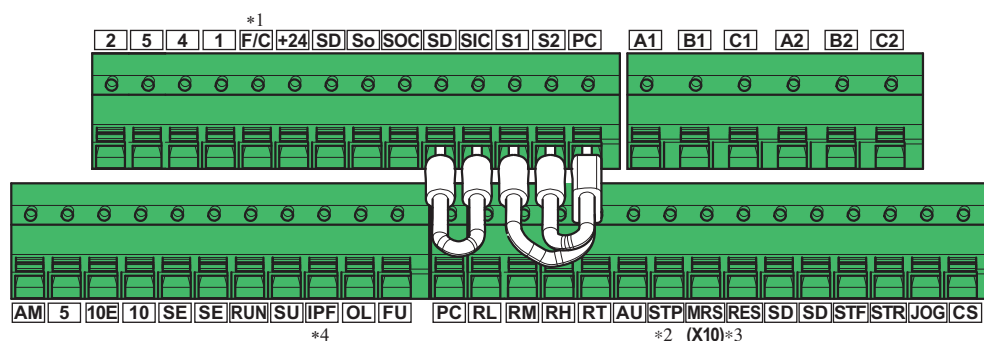

*1 This terminal operates as the terminal FM for the FM type, and as the terminal CA for the CA type.

*2 Represents the terminal STOP.

*3 The X10 signal is assigned in the initial setting.

*4 No signal is assigned in the initial setting.

◆ Wiring method

• Power supply connection

For the control circuit wiring, strip off the sheath of a cable, and use it with a blade terminal. For a single wire, strip off the sheath of the wire and apply directly.

Insert the blade terminal or the single wire into a socket of the terminal.

- (1) Strip off the sheath for the below length. If the length of the sheath peeled is too long, a short circuit may occur with neighboring wires. If the length is too short, wires might come off.

Wire the stripped cable after twisting it to prevent it from becoming loose. In addition, do not solder it.

Cable sheath stripping length



- (2) Crimp the blade terminal.

Insert wires to a blade terminal, and check that the wires come out for about 0 to 0.5 mm from a sleeve.

Check the condition of the blade terminal after crimping. Do not use a blade terminal of which the crimping is inappropriate, or the face is damaged.

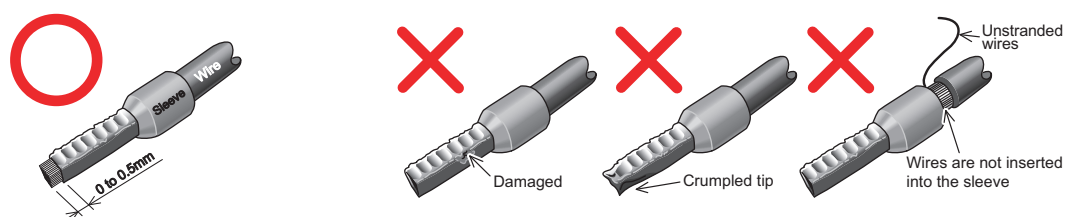

- Blade terminals commercially available (as of January 2017)

Phoenix Contact Co., Ltd.

Cable gauge (mm ²)	Ferrule terminal model			Crimping tool name
	With insulation sleeve	Without insulation sleeve	For UL wire *1	
0.3	AI 0, 34-10TQ	-	-	CRIMPFOX 6
0.5	AI 0, 5-10WH	-	AI 0, 5-10WH-GB	
0.75	AI 0, 75-10GY	A 0, 75-10	AI 0, 75-10GY-GB	
1	AI 1-10RD	A 1-10	AI 1-10RD/1000GB	
1.25, 1.5	AI 1, 5-10BK	A 1, 5-10	AI 1, 5-10BK/1000GB*2	
0.75 (for two wires)	AI-TWIN 2 × 0, 75-10GY	-	-	

*1 A ferrule terminal with an insulation sleeve compatible with the MTW wire which has a thick wire insulation.

*2 Applicable for the terminals A1, B1, C1, A2, B2, and C2 only.

Control circuit

NICHIFU Co.,Ltd.

Cable gauge (mm ²)	Blade terminal product number	Insulation cap product number	Crimping tool product number
0.3 to 0.75	BT 0.75-11	VC 0.75	NH 69

(3) Insert the wires into a socket.

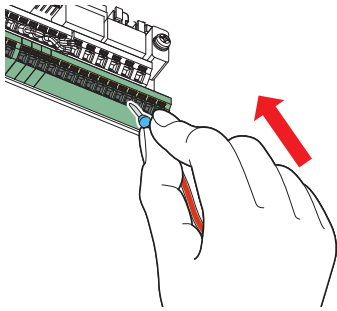

When using a single wire or stranded wires without a blade terminal, push the open/close button all the way down with a flathead screwdriver, and insert the wire.

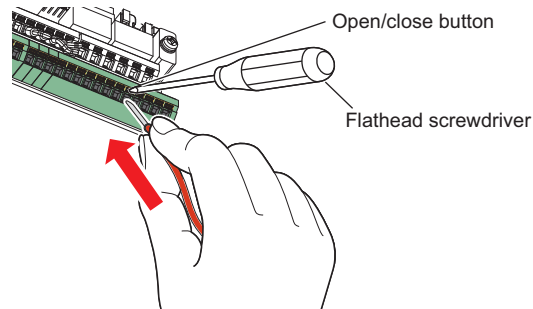

NOTE

- When using stranded wires without a blade terminal, twist enough to avoid short circuit with a nearby terminals or wires.
- Place the flathead screwdriver vertical to the open/close button. In case the blade tip slips, it may cause an inverter damage or injury.

• Wire removal
Pull the wire while pushing the open/close button all the way down firmly with a flathead screwdriver.

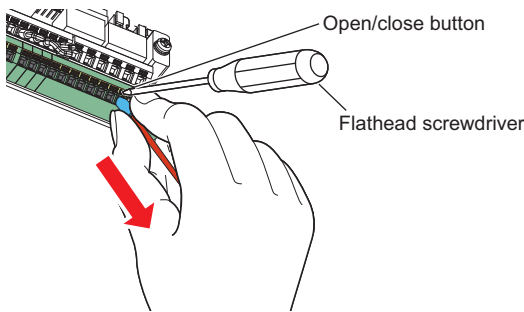

NOTE

- Pulling out the wire forcefully without pushing the open/close button all the way down may damage the terminal block.
- Use a small flathead screwdriver (tip thickness: 0.4 mm/tip width: 2.5 mm).
If a flathead screwdriver with a narrow tip is used, terminal block may be damaged.

Commercially available products (as of February 2016)

Name	Model	Manufacturer
Driver	SZF 0- 0,4 × 2,5	Phoenix Contact Co., Ltd. Contact Co., Ltd.

- Place the flathead screwdriver vertical to the open/close button. In case the blade tip slips, it may cause an inverter damage or injury.

◆ Common terminals of the control circuit (SD, PC, 5, SE)

- Terminals SD (sink logic), PC (source logic), 5, and SE are common terminals (0V) for I/O signals. (All common terminals are isolated from each other.) Do not earth (ground) these terminals. Avoid connecting the terminal SD (sink logic) with 5, the terminal PC (source logic) with 5, and the terminal SE with 5.
- In the sink logic, terminal SD is a common terminal for the contact input terminals (STF, STR, STP (STOP), RH, RM, RL, JOG, RT, MRS, RES, AU, CS) and the pulse train output terminal (FM*1). The open collector circuit is isolated from the internal control circuit by photocoupler.
- In the source logic, terminal PC is a common terminal for the contact input terminals (STF, STR, STP (STOP), RH, RM, RL, JOG, RT, MRS, RES, AU, CS). The open collector circuit is isolated from the internal control circuit by photocoupler.
- Terminal 5 is a common terminal for the frequency setting terminals (2, 1 or 4) and the analog output terminals (AM, CA*2). It should be protected from external noise using a shielded or twisted cable.
- Terminal SE is a common terminal for the open collector output terminals (RUN, SU, OL, IPF, FU). The contact input circuit is isolated from the internal control circuit by photocoupler.

*1 Terminal FM is provided in the FM-type inverter.

*2 Terminal CA is provided in the CA-type inverter.

◆ Signal inputs by contactless switches

The contact input terminals of the inverter (STF, STR, STP (STOP), RH, RM, RL, JOG, RT, MRS, RES, AU, CS) can be controlled using a transistor instead of a contact switch as shown below.

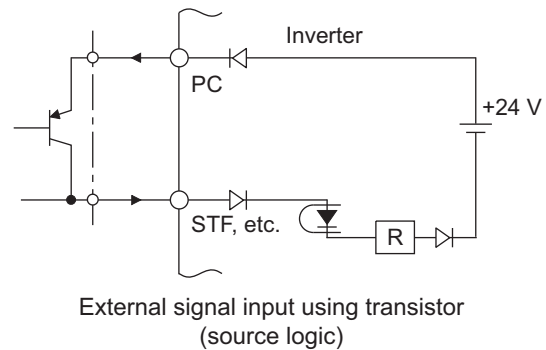
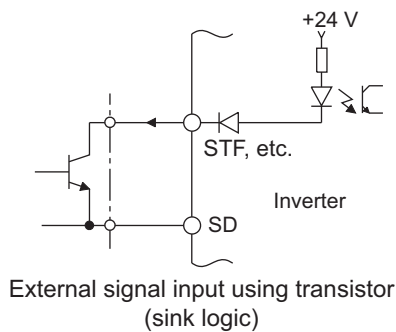

2.6.5 Wiring precautions

- It is recommended to use a cable of 0.3 to 0.75 mm² for the connection to the control circuit terminals.
 - The wiring length should be 30 m (200 m for the terminal FM) at the maximum.
 - Use two or more parallel micro-signal contacts or twin contacts to prevent contact faults when using contact inputs since the control circuit input signals are micro-currents.
 - To suppress EMI, use shielded or twisted cables for the control circuit terminals and run them away from the main and power circuits (including the 200V relay sequence circuit). For the cables connected to the control circuit terminals, connect their shields to the common terminal of the connected control circuit terminal. When connecting an external power supply to the terminal PC, however, connect the shield of the power supply cable to the negative side of the external power supply. Do not directly earth (ground) the shield to the enclosure, etc.
 - Always apply a voltage to the fault output terminals (A1, B1, C1, A2, B2, C2) via a relay coil, lamp, etc.
 - Separate the wiring of the control circuit away from the wiring of the main circuit.
- Make cuts in rubber bush of the inverter side and lead the wires through.

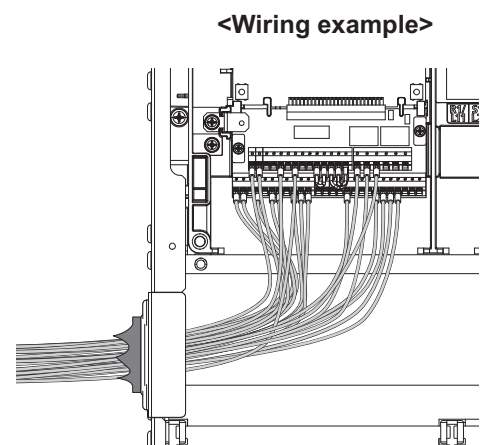
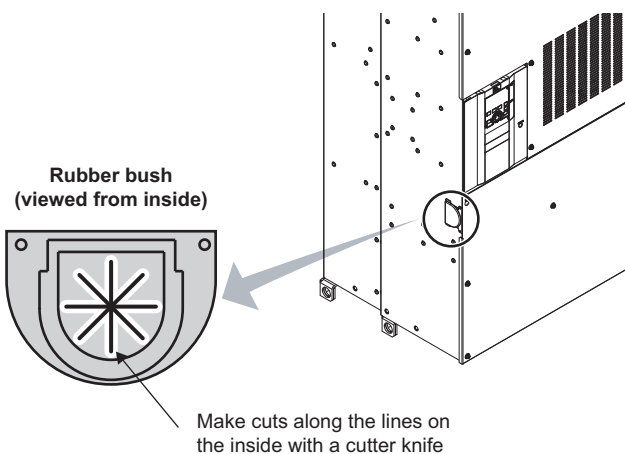
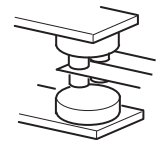
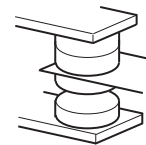

2.6.6 When using separate power supplies for the control circuit and the main circuit

◆ Cable size for the control circuit power supply (terminals R1/L11 and S1/L21)

- Terminal screw size: M4
- Cable gauge: 0.75 mm² to 2 mm²
- Tightening torque: 1.5 N·m

◆ Connected to

When a fault occurs, opening of the electromagnetic contactor (MC) on the inverter power supply side results in power loss in the control circuit, disabling the fault output signal retention. Terminals R1/L11 and S1/L21 are provided to hold a fault signal. In this case, connect the power supply terminals R1/L11 and S1/L21 of the control circuit to the input side of the MC. The terminals R1/L11 and S1/L21 are connected to the terminals P/+ and N/- with a jumper respectively. Do not connect the power cable to incorrect terminals. Doing so may damage the inverter.

<Connection diagram>

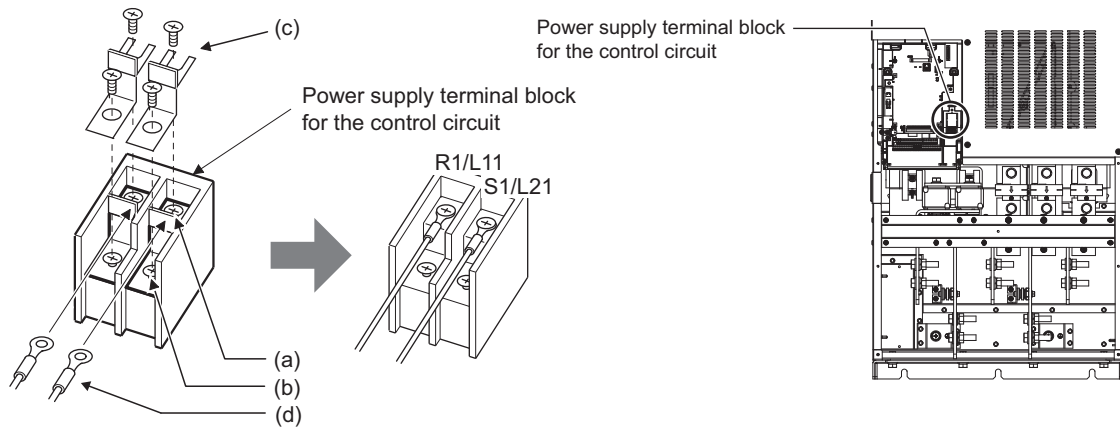
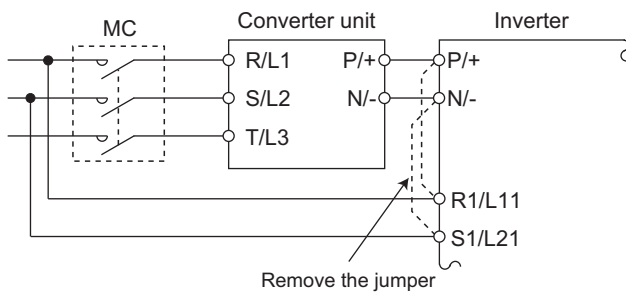

- Remove the upper screws.
- Remove the lower screws.
- Pull the jumper toward you to remove.
- Connect the separate power supply cable for the control circuit to the upper terminals (R1/L11, S1/L21).

NOTE

- When using separate power supplies, always remove the jumpers from terminals R1/L11 and S1/L21. The inverter may be damaged if the jumpers are not removed.
- The voltage should be the same as that of the main control circuit when the control circuit power is supplied from other than the input side of the MC.
- The power capacity necessary when separate power is supplied from R1/L11 and S1/L21 is 80 VA.
- If the main circuit power is switched OFF (for 0.1 s or more) then ON again, the inverter is reset and a fault output will not be held.

2.6.7 When supplying 24 V external power to the control circuit

Connect the 24 V external power supply across terminals +24 and SD. The 24 V external power supply enables I/O terminal ON/OFF operation, operation panel displays, control functions, and communication during communication operation even during power-OFF of inverter's main circuit power supply. When the main circuit power supply is turned ON, the power supply changes from the 24 V external power supply to the main circuit power supply.

◆ Specification of the applied 24 V external power supply

Item	Rated specification
Input voltage	DC23 to 25.5 V
Input current	1.4 A or lower

Commercially available products (as of April 2019)

Model	Product overview	Manufacturer
S8FS-G05024C*1	Specifications: Capacity 50 W, output voltage 24 VDC, output current 2.2 A Installation method: Direct installation, screw type terminal block with a cover Input: Single-phase 100 to 240 VAC	OMRON Corporation
S8VK-S06024*1	Specifications: Capacity 60 W, output voltage 24 VDC, output current 2.5 A Installation method: DIN rail installation, push-in (spring) type terminal block Input: Single-phase 100 to 240 VAC	
S8VK-WA24024*1	Specifications: Capacity 240 W, output voltage 24 VDC, output current 10 A Installation method: DIN rail installation, push-in (spring) type terminal block Input: Three-phase 200 to 240 VAC	

*1 For the latest information about OMRON power supply, contact OMRON corporation.

◆ Starting and stopping the 24 V external power supply operation

- Supplying 24 V external power while the main circuit power is OFF starts the 24 V external power supply operation. Likewise, turning OFF the main circuit power while supplying 24 V external power starts the 24 V external power supply operation.
- Turning ON the main circuit power stops the 24 V external power supply operation and enables the normal operation.

NOTE

- When the 24 V external power is supplied while the main circuit power supply is OFF, the inverter operation is disabled.
- In the initial setting, when the main power supply is turned ON during the 24 V external power supply operation, a reset is performed in the inverter, then the power supply changes to the main circuit power supply. (The reset can be disabled using Pr.30.)

◆ Confirming the 24 V external power supply input

- During the 24 V external power supply operation, "EV" flickers on the operation panel. The alarm lamp also flickers. Thus, the 24 V external power supply operation can be confirmed even when the operation panel is removed.

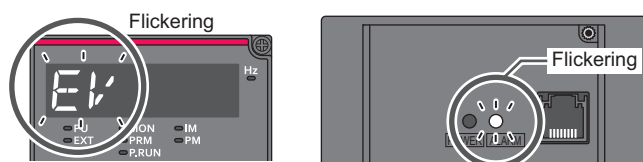

- During the 24 V external power supply operation, the 24 V external power supply operation signal (EV) is output. To use the EV signal, set "68 (positive logic) or 168 (negative logic)" in one of Pr.190 to Pr.196 (output terminal function selection) to assign function to an output terminal.

◆ Operation while the 24 V external power is supplied

- Fault history and parameters can be read and parameters can be written (when the parameter write from the operation panel is enabled) using the operation panel keys.
- The safety stop function is disabled during the 24 V external power supply operation.
- During the 24 V external power supply operation, monitored items and signals related to inputs to main circuit power supply, such as output current, and converter output voltage, are invalid.
- The alarms, which have occurred when the main circuit power supply is ON, continue to be output after the power supply is changed to the 24 V external power supply. Perform the inverter reset or turn OFF then ON the power to reset the faults.
- The output data is retained when "1 or 11" is set in **Pr.495 Remote output selection**.

NOTE

- Inrush current equal to or higher than the 24 V external power supply specification may flow at power-ON. Confirm that the power supply and other devices are not affected by the inrush current and the voltage drop caused by it. Depending on the power supply, the inrush current protection may be activated to disable the power supply. Select the power supply and capacity carefully.
- When the wiring length between the external power supply and the inverter is long, the voltage often drops. Select the appropriate wiring size and length to keep the voltage in the rated input voltage range.
- In a serial connection of several inverters, the current increases when it flows through the inverter wiring near the power supply. The increase of the current causes voltage to drop further. Use the inverter after confirming that the input voltage of each converter unit is within the rated input voltage range. Depending on the power supply, the inrush current protection may be activated to disable the power supply. Select the power supply and capacity carefully.
- "E.SAF" or "E.P24" may appear when the start-up time of the 24 V power supply is too long (less than 1.5 V/s) in the 24 V external power supply operation.
- "E.P24" may appear when the 24 V external power supply input voltage is low. Check the external power supply input.
- Do not touch the control circuit terminal block (circuit board) during the 24 V power supply operation (when conducted). Otherwise you may get an electric shock or burn.

2.6.8 Safety stop function

◆ Function description

The terminals related to the safety stop function are shown below.

Terminal symbol	Terminal function description	
S1 *1	For input of the safety stop channel 1.	Between S1 and SIC, S2 and SIC Open: In safety stop mode Short: Other than the safety stop mode.
S2 *1	For input of the safety stop channel 2.	
SIC *1	Common terminal for terminals S1 and S2.	
So (SO)	Outputs when an alarm or failure is detected. The signal is output when no internal safety circuit failure*2 exists.	OFF: Internal safety circuit failure*2 ON: No internal safety circuit failure*2
SOC	Open collector output (terminal So (SO)) common	

*1 In the initial status, terminals S1 and PC, S2 and PC, and SIC and SD are respectively shorted with shorting wires. To use the safety stop function, remove all the shorting wires, and then connect to the safety relay module as shown in the connection diagram.

*2 At an internal safety circuit failure, the operation panel displays one of the faults shown on the next page.

NOTE

- Use the terminal So (SO) to output a fault and to prevent restarting of the inverter. The signal cannot be used as safety stop input terminal to other devices.

◆ Connection diagram

To prevent restart at fault occurrence, connect terminals So (SO) and SOC to the reset button, which are the feedback input terminals of the safety relay module.

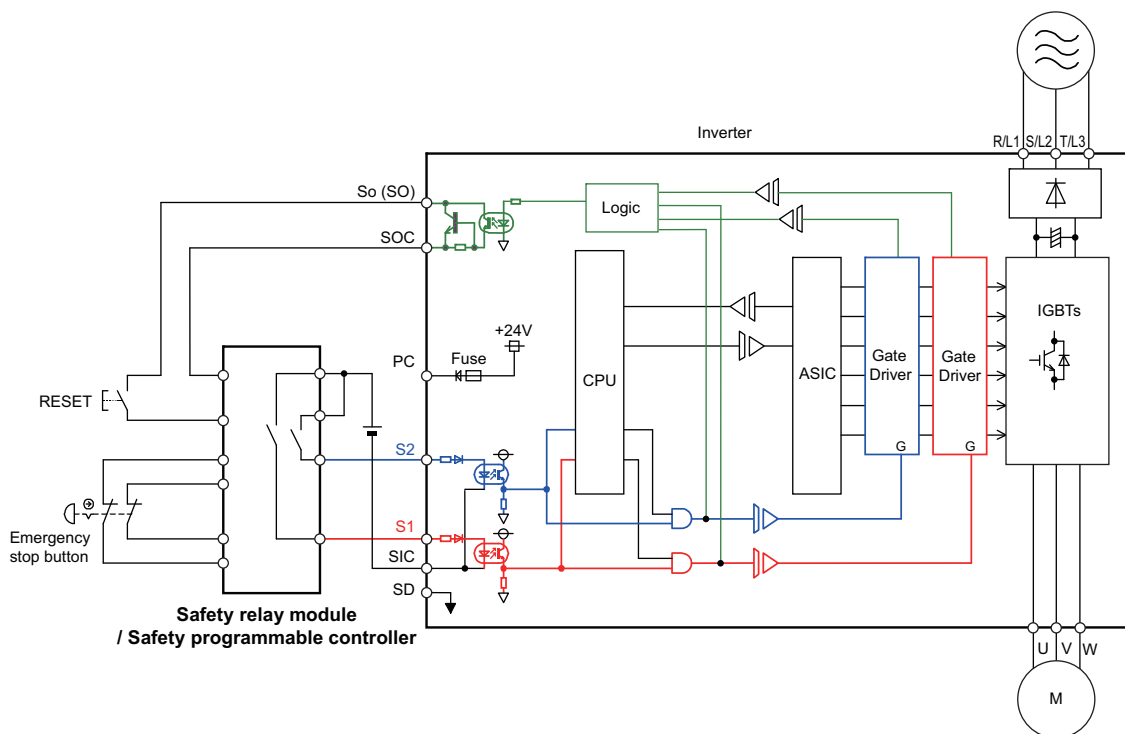

◆ Safety stop function operation

Input power	Internal safety circuit status	Input terminal *1,*2		Output terminal	Output signal *8,*9,*10	Inverter running status	Operation panel indication	
		S1	S2	So (SO)	SAFE		E.SAF *6	SA *7
OFF	—	—	—	OFF	OFF	Output shutoff (Safe state)	Not displayed	Not displayed
ON	Normal	ON	ON	ON *3	OFF	Drive enabled	Not displayed	Not displayed
	Normal	ON	OFF	OFF *4	OFF *4	Output shutoff (Safe state)	Displayed	Displayed
	Normal	OFF	ON	OFF *4	OFF *4	Output shutoff (Safe state)	Displayed	Displayed
	Normal	OFF	OFF	ON *3	ON *3	Output shutoff (Safe state)	Not displayed	Displayed
	Fault	ON	ON	OFF	OFF	Output shutoff (Safe state)	Displayed	Not displayed *5
	Fault	ON	OFF	OFF	OFF	Output shutoff (Safe state)	Displayed	Displayed
	Fault	OFF	ON	OFF	OFF	Output shutoff (Safe state)	Displayed	Displayed
Fault	OFF	OFF	OFF	OFF	Output shutoff (Safe state)	Displayed	Displayed	

- *1 ON: The transistor is conducted. OFF: The transistor is not conducted.
- *2 When not using the safety stop function, short across terminals S1 and PC, S2 and PC, and SIC and SD to use the inverter. (In the initial status, terminals S1 and PC, S2 and PC, and SIC and SD are respectively shorted with shorting wires.)
- *3 If any of the faults shown in the following table occurs, terminal So (SO) and the SAFE signal turns OFF.

Fault type	Operation panel indication
Option fault	E.OPT
Communication option fault	E.OP1 to E.OP3
Parameter storage device fault (control circuit board)	E.PE
Retry count excess	E.RET
Parameter storage device fault (main circuit board)	E.PE2
Operation panel power supply short circuit/RS-485 terminals power supply short circuit	E.CTE
24 VDC power fault	E.P24

Fault type	Operation panel indication
Safety circuit fault	E.SAF
Overspeed occurrence	E.OS
Speed deviation excess detection	E.OSD
Signal loss detection	E.ECT
Excessive position fault	E.OD
Brake sequence fault	E.MB1 to E.MB7
Encoder phase fault	E.EP
Magnetic pole position unknown	E.MP
CPU fault	E.CPU
	E.5 to E.7
Internal circuit fault	E.13

- *4 When the internal safety circuit is operated normally (no faults occurs), terminal So (SO) and the SAFE signal remain ON until "E.SAF" is displayed. Terminal So (SO) and the SAFE signal turn OFF when "E.SAF" is displayed.
- *5 SA is displayed when terminals S1 and S2 are identified as OFF due to the internal safety circuit failure.
- *6 If another fault occurs at the same time as E.SAF, the other fault can be displayed.
- *7 If another warning occurs at the same time as SA, the other warning can be displayed.
- *8 The ON/OFF state of the output signal is the one for the positive logic. The ON and OFF are reversed for the negative logic.
- *9 To assign the function of the SAFE signal to an output terminal, set either value shown in the following table in any parameter from Pr.190 to Pr.196 (Output terminal function selection).

Output signal	Pr.190 to Pr.196 setting	
	Positive logic	Negative logic
SAFE	80	180

- *10 The use of SAFE signal has not been certified for compliance with safety standards.

For more details, refer to the Safety stop function instruction manual. (A PDF copy can be found in the enclosed CD-ROM. For how to use this CD-ROM, refer to [page 123](#).)

2.7 Communication connectors and terminals

2.7.1 PU connector

◆ Mounting the operation panel or parameter unit on the enclosure surface

- Having an operation panel or a parameter unit on the enclosure surface is convenient. With a connection cable, the operation panel or the parameter unit can be mounted to the enclosure surface and connected to the inverter. Use the option FR-CB2[], or connectors and cables available on the market. (To install the operation panel, the optional connector (FR-ADP) is required.) Securely insert one end of the connection cable until the stoppers are fixed.

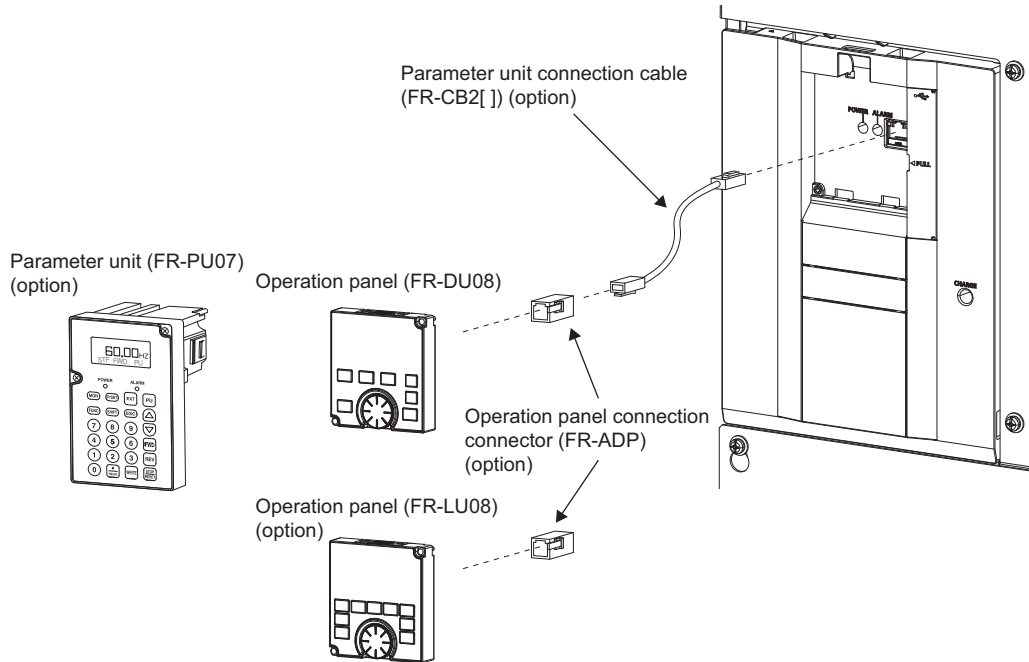

NOTE

- Refer to the following table when fabricating the cable on the user side. Keep the total cable length within 20 m.
- Commercially available products (as of February 2015)

Name	Model	Manufacturer
Communication cable	SGLPEV-T (Cat5e/300 m) 24AWG × 4P	Mitsubishi Cable Industries, Ltd.
RJ-45 connector	5-554720-3	Tyco Electronics

◆ Communication operation

- Using the PU connector enables communication operation from a personal computer, etc. When the PU connector is connected with a personal, FA or other computer by a communication cable, a user program can run to monitor the inverter or read and write parameters. Communication can be performed with the Mitsubishi inverter protocol (computer link operation). (For details, refer to the FR-A800 Instruction Manual (Detailed).)

2.7.2 CC-Link IE Field Network function

◆CC-Link IE Field Network communication specifications

Item	Description			
Transmission speed	1 Gbps			
Communication method	Token passing			
Number of units connected	120 units at max. (64 units when all stations are inverters handling 128-word transmissions.) Different devices can be connected together.			
Maximum distance between nodes	100 m			
Maximum number of branches	No upper limit within the same Ethernet system			
Topology	Line, star, ring, or a combination of line and star			
Connection cable	Ethernet cable (IEEE 802.3 1000BASE-T compliant cable or ANSI/TIA/EIA-568-B (Category 5e) compliant shielded 4-pair branched cable)			
Connector	Shielded RJ-45			
Node type	Intelligent device station	Maximum cyclic size (of one node)	RX	64 bits
			RY	64 bits
			RWr	128 words
			RWw	128 words

◆Parts

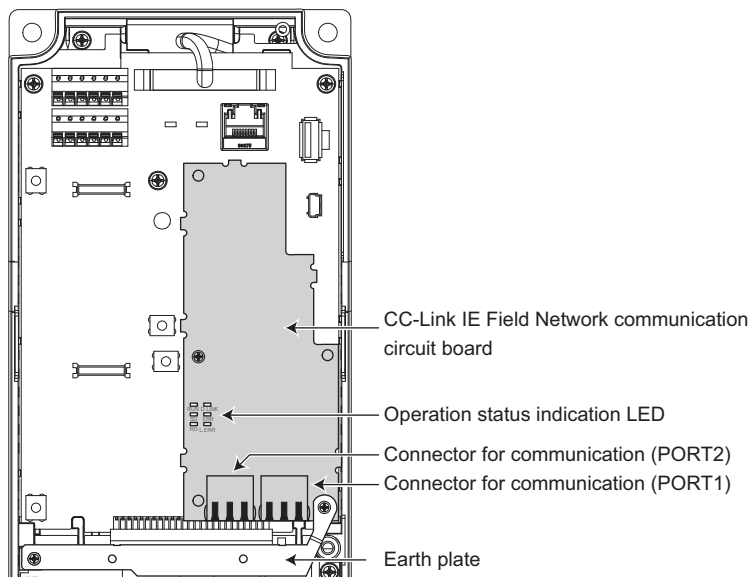

NOTE

- Do not remove the CC-Link IE Field Network communication circuit board or the earth plate.

◆Connection cable

For wiring, use the 1000BASE-T compliant Ethernet cables.

Ethernet cable	Connector	Type
Category 5e or higher (Double shielded/STP) Straight cable	RJ-45 connector	The following conditioning cables: <ul style="list-style-type: none"> IEEE802.3 (1000BASE-T) ANSI/TIA/EIA-568-B (Category 5e)

NOTE

- For CC-Link IE Field Network wiring, use the recommended wiring components by CC-Link Partner Association.
- Cables for CC-Link IE Controller Network cannot be used for CC-Link IE Field Network.
- Some cable connector shapes are not compatible with CC-Link IE Field Network communication connector.

◆ Hubs

Use hubs that meet the conditions listed below:

- Compliance with the IEEE802.3 (1000BASE-T)
- Support of the auto MDI/MDI-X function
- Support of the auto-negotiation function
- Switching hub (layer 2 switch)*1

*1 A repeater hub is not available.

Operation is not guaranteed if the hubs do not meet these conditions.

Industrial switching hub

Type	Manufacturer
NZ2EHG-T8	Mitsubishi Electric Corporation

◆ Ethernet cable connection

- Connect or remove an Ethernet cable after switching the power of the inverter OFF.
- PORT1 and PORT2 do not need to be distinguished.
 - When only one connector is used in star topology, either PORT1 or PORT2 is applicable.
 - When using two connectors for line topology and ring topology, an Ethernet cable can be connected to the connectors in any combination. For example, the cable can be connected between PORT1s or between PORT1 and PORT2.

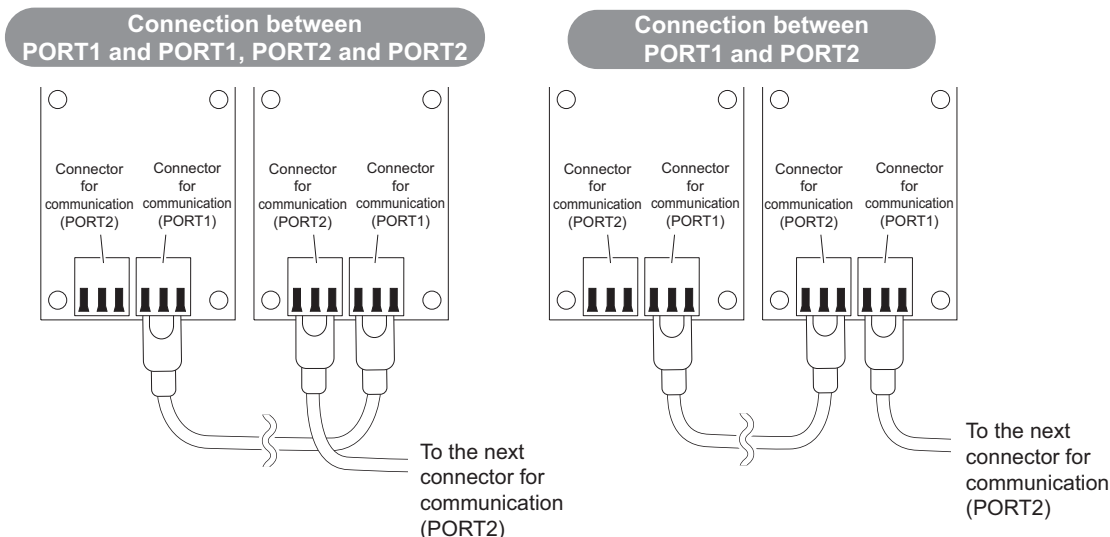

NOTE

- Ethernet is a registered trademark of Xerox Corporation of the United States.
- For the CC-Link IE Field Network, refer to the FR-A800 Instruction Manual (Detailed).

2.7.3 USB connector

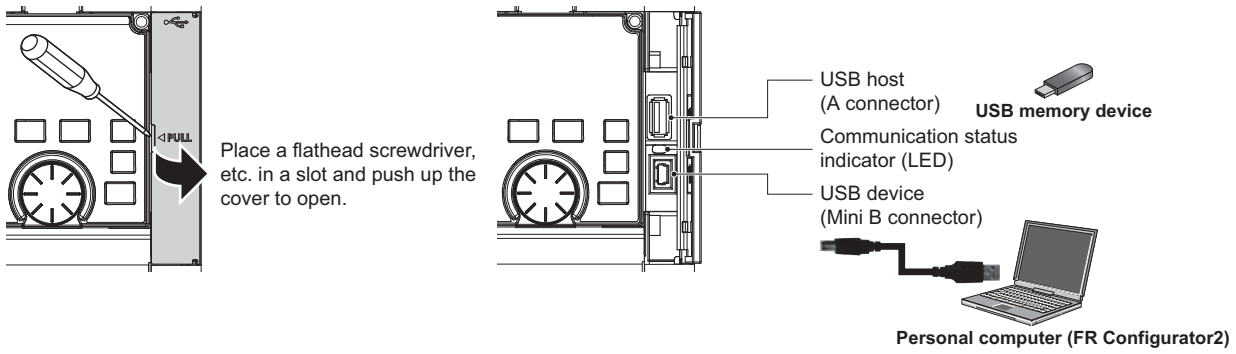

◆ USB host communication

Interface		Conforms to USB1.1
Transmission speed		12 Mbps
Wiring length		Maximum 5 m
Connector		USB A connector (receptacle)
Compatible USB memory	(Format)	FAT32
	Capacity	1 GB or more (used in the recorder mode of the trace function)
	Encryption function	Not available

- Different inverter data can be saved in a USB memory device. The USB host communication enables the following functions.

Function	Description
Parameter copy	<ul style="list-style-type: none"> • Copies the parameter setting from the inverter to the USB memory device. A maximum of 99 parameter setting files can be saved in a USB memory device. • The parameter setting data copied in the USB memory device can be copied to other inverters. This function is useful in backing up the parameter setting or for sharing the parameter setting among multiple inverters. • The parameter setting data copied in the USB memory device can be saved in a personal computer and edited in FR Configurator 2.
Trace	<ul style="list-style-type: none"> • The monitored data and output status of the signals can be saved in a USB memory device. • The saved data can be imported to FR Configurator2 to diagnose the operating status of the inverter.
PLC function data copy	<ul style="list-style-type: none"> • This function copies the PLC function project data to a USB memory device when the PLC function is used. • The PLC function project data copied in the USB memory device can be copied to other inverters. • This function is useful in backing up the parameter setting and for allowing multiple inverters to operate by the same sequence programs.

- When the inverter recognizes the USB memory device without any problem, **USB--A** is briefly displayed on the operation panel.
- When the USB memory device is removed, **USB--** is briefly displayed on the operation panel.
- The operating status of the USB host can be checked on the LED display of the inverter.

LED display status	Operating status
OFF	No USB connection.
ON	The communication is established between the inverter and the USB device.
Flickering rapidly	The USB memory device is being accessed. (Do not remove the USB memory device.)
Flickering slowly	Error in the USB connection.

- When a device such as a USB battery charger is connected to the USB connector and an excessive current (500 mA or more) flows, USB host error **UF** (UF warning) is displayed on the operation panel.
- If a UF warning occurs, disconnect the USB device and set **Pr.1049 = "1"** to cancel the USB error. (The UF warning can also be canceled by resetting the inverter power or resetting with the RES signal.)

NOTE

- Do not connect devices other than a USB memory device to the inverter.
- If a USB device is connected to the inverter via a USB hub, the inverter cannot recognize the USB memory device properly.
- For the details of usage, refer to the FR-A800 Instruction Manual (Detailed).

◆USB device communication

A USB (Ver. 1.1) cable connects the inverter with a personal computer. Parameter setting and monitoring can be performed by FR Configurator 2.

Interface	Conforms to USB1.1
Transmission speed	12 Mbps
Wiring length	Maximum 5 m
Connector	USB mini B connector (receptacle)
Power supply	Self-powered

NOTE

- For the details of FR Configurator2, refer to the Instruction Manual of FR Configurator2.

2.7.4 RS-485 terminal block

◆Communication operation

Conforming standard	EIA-485 (RS-485)
Transmission format	Multidrop link
Communication speed	115200 bps maximum
Overall length	500 m
Connection cable	Twisted pair cable (4 pairs)

The RS-485 terminals enables communication operation from a personal computer, etc. When the PU connector is connected with a personal, FA or other computer by a communication cable, a user program can run to monitor the inverter or read and write parameters.

Communication can be performed with the Mitsubishi inverter protocol (computer link operation) and MODBUS RTU protocol. (For details, refer to the FR-A800 Instruction Manual (Detailed).)

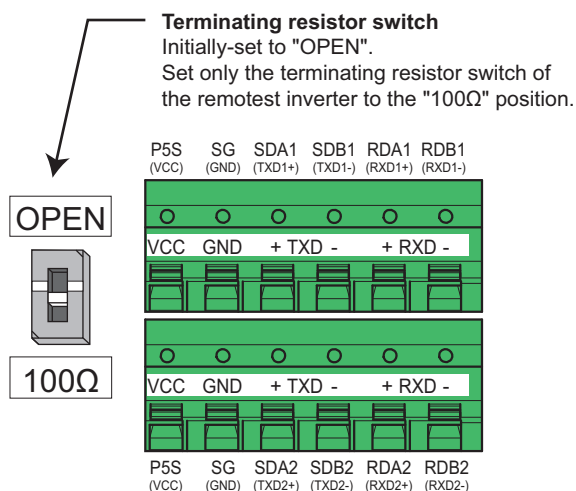

NOTE

- To avoid malfunction, keep the RS-485 terminal wires away from the control circuit board.
- For wiring of the RS-485 terminals used with a plug-in option, lead the wires on the left side of the plug-in option.

2.8 Connection of motor with encoder (vector control)

Using encoder-equipped motors together with a vector control compatible option enables speed, torque, and positioning control operations under orientation control, encoder feedback control, and full-scale vector control. This section explains wiring for use of the FR-A8AP.

◆ Appearance and parts name of FR-A8AP

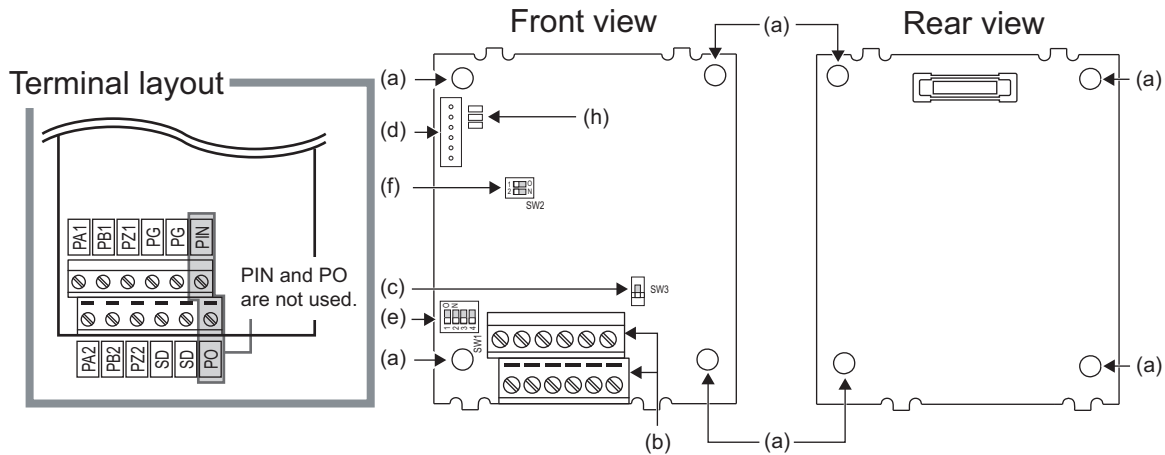

Symbol	Name	Description	Refer to page
a	Mounting hole	Used for installation to the inverter.	—
b	Terminal block	Connected with the encoder.	59
c	Encoder type selection switch (SW3)	Switches the encoder type (differential line driver/complementary).	57
d	CON2 connector	Used for extension.	—
e	Terminating resistor selection switch (SW1)	Switches ON or OFF the internal terminating resistor.	57
f	Switch for manufacturer setting (SW2)	Do not change from the initially-set status. (Switches 1 and 2 are OFF  .)	—
g	Connector	Connected to the option connector of the inverter.	9
h	LED for manufacturer check	Not used.	—

◆ Terminals of the FR-A8AP

Terminal symbol	Terminal name	Description
PA1	Encoder A-phase signal input terminal	A-, B- and Z-phase signals are input from the encoder.
PA2	Encoder A-phase inverse signal input terminal	
PB1	Encoder B-phase signal input terminal	
PB2	Encoder B-phase inverse signal input terminal	
PZ1	Encoder Z-phase signal input terminal	
PZ2	Encoder Z-phase inverse signal input terminal	
PG	Encoder power supply (positive side) input terminal	Input terminal for the encoder power supply. Connect the external power supply (5 V, 12 V, 15 V, 24 V) and the encoder power cable. When the encoder output is the differential line driver type, only 5 V can be input. Make the voltage of the external power supply same as the encoder output voltage. (Check the encoder specification.)
SD	Encoder power supply ground terminal	
PIN	Not used.	
PO		

NOTE

- When the encoder's output voltage differs from its input power supply voltage, the signal loss detection (E.ECT) may occur.
- Incorrect wiring or faulty setting to the encoder will cause a fault such as an overcurrent (E.OC[]) and an inverter overload (E.THT).
Correctly perform the encoder wiring and setting.

◆ Switches of the FR-A8AP

• Encoder type selection switch (SW3)

Selects either the differential line driver or complementary setting.

It is initially set to the differential line driver. Switch its position according to the output circuit.

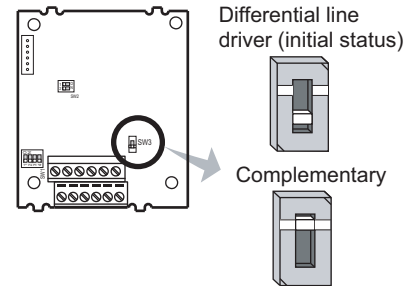

• Terminating resistor selection switch (SW1)

Selects ON/OFF of the internal terminating resistor.

Set the switch to ON (initial status) when an encoder output type is differential line driver, and set to OFF when complementary.

ON: with internal terminating resistor (initial status)

OFF: without internal terminating resistor

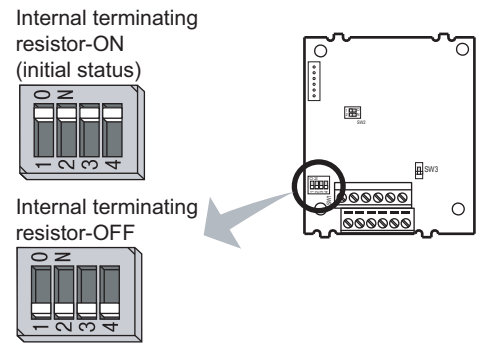

NOTE

- Set all switches to the same setting (ON/OFF).
- Set the switch "OFF" when sharing an encoder with another unit (NC (computerized numerical controller), etc.) having a terminating resistor under the differential line driver setting.
- Prepare an encoder's power supply (5 V/12 V/15 V/24 V) according to the encoder's output voltage. When the control terminal option FR-A8TP is installed, 24 V power supply can be provided from the FR-A8TP. When the encoder output is the differential line driver type, only 5 V can be input.
- The SW2 switch is for manufacturer setting. Do not change the setting.
- When the power supply of the inverter is turned OFF, also turn off the power supply of the encoder. Otherwise, the plug-in option may be damaged.

◆ Encoder specification

Item	Specification
Resolution	0 to 4096 Pulse/Rev (setting by Pr. 369)
Power supply voltage	5 V, 12 V, 15 V, 24 V
Output signal form	A, B phases (90° phase shift) Z phase: 1 pulse/rev
Output circuit	Differential line driver or complementary

◆ Encoder cable

FR-JCBL	FR-V7CBL																
<table border="1" style="margin: auto;"> <thead> <tr style="background-color: #e0f7fa;"> <th>Model</th> <th>Length L (m)</th> </tr> </thead> <tbody> <tr> <td>FR-JCBL5</td> <td>5</td> </tr> <tr> <td>FR-JCBL15</td> <td>15</td> </tr> <tr> <td>FR-JCBL30</td> <td>30</td> </tr> </tbody> </table>	Model	Length L (m)	FR-JCBL5	5	FR-JCBL15	15	FR-JCBL30	30	<p>• Shield earthing P-clip is included.</p> <table border="1" style="margin: auto;"> <thead> <tr style="background-color: #e0f7fa;"> <th>Model</th> <th>Length L (m)</th> </tr> </thead> <tbody> <tr> <td>FR-V7CBL5</td> <td>5</td> </tr> <tr> <td>FR-V7CBL15</td> <td>15</td> </tr> <tr> <td>FR-V7CBL30</td> <td>30</td> </tr> </tbody> </table>	Model	Length L (m)	FR-V7CBL5	5	FR-V7CBL15	15	FR-V7CBL30	30
Model	Length L (m)																
FR-JCBL5	5																
FR-JCBL15	15																
FR-JCBL30	30																
Model	Length L (m)																
FR-V7CBL5	5																
FR-V7CBL15	15																
FR-V7CBL30	30																
<p>FR-A800 (FR-A8AP)</p> <p style="text-align: center;">D/MS3106B20-29S (As viewed from wiring side)</p>	<p>FR-A800 (FR-A8AP)</p> <p style="text-align: center;">D/MS3106B20-29S (As viewed from wiring side)</p>																

*1 As the terminal block of the FR-A8AP is an insertion type, cables need to be treated. (Refer to the following description.)

- As the terminal block of the FR-A8AP is an insertion type, cables need to be treated when the encoder cables of the inverter are crimping terminals. Cut the crimping terminal of the encoder cable and strip its sheath to make its cable wires loose.

Also, treat the shielding wires of the shielded twisted pair cable to ensure that they will not contact conductive areas. Wire the stripped cable after twisting it to prevent it from becoming loose. In addition, do not solder it.

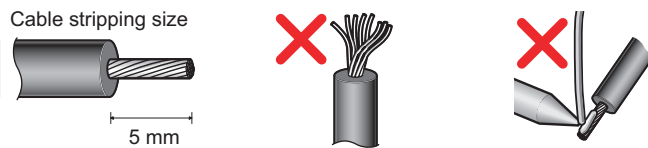

NOTE

- Information on blade terminals
Commercially available products (as of January 2017)
Phoenix Contact Co., Ltd.

Terminal screw size	Cable gauge (mm ²)	Ferrule terminal model		Crimping tool name
		(With insulation sleeve)	(Without insulation sleeve)	
M2	0.3	AI 0,34-6TQ	A 0,34-7	CRIMPFOX 6
	0.5	AI 0,5-6WH	A 0,5-6	

NICHIFU Co.,Ltd.

Terminal screw size	Cable gauge (mm ²)	Blade terminal product number	Insulation cap product number	Crimping tool product number
M2	0.3 to 0.75	BT 0.75-7	VC 0.75	NH 69

- When using a blade terminal (without insulation sleeve), take caution that the twisted wires do not come out.

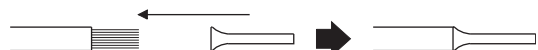

- Connection terminal compatibility table

Encoder cable	FR-V7CBL	FR-JCBL	
FR-A8AP terminal	PA1	PA	PA
	PA2	Do not connect anything to this.	PAR
	PB1	PB	PB
	PB2	Do not connect anything to this.	PBR
	PZ1	PZ	PZ
	PZ2	Do not connect anything to this.	PZR
	PG	PG	5E
	SD	SD	AG2

◆Wiring example

- Speed control

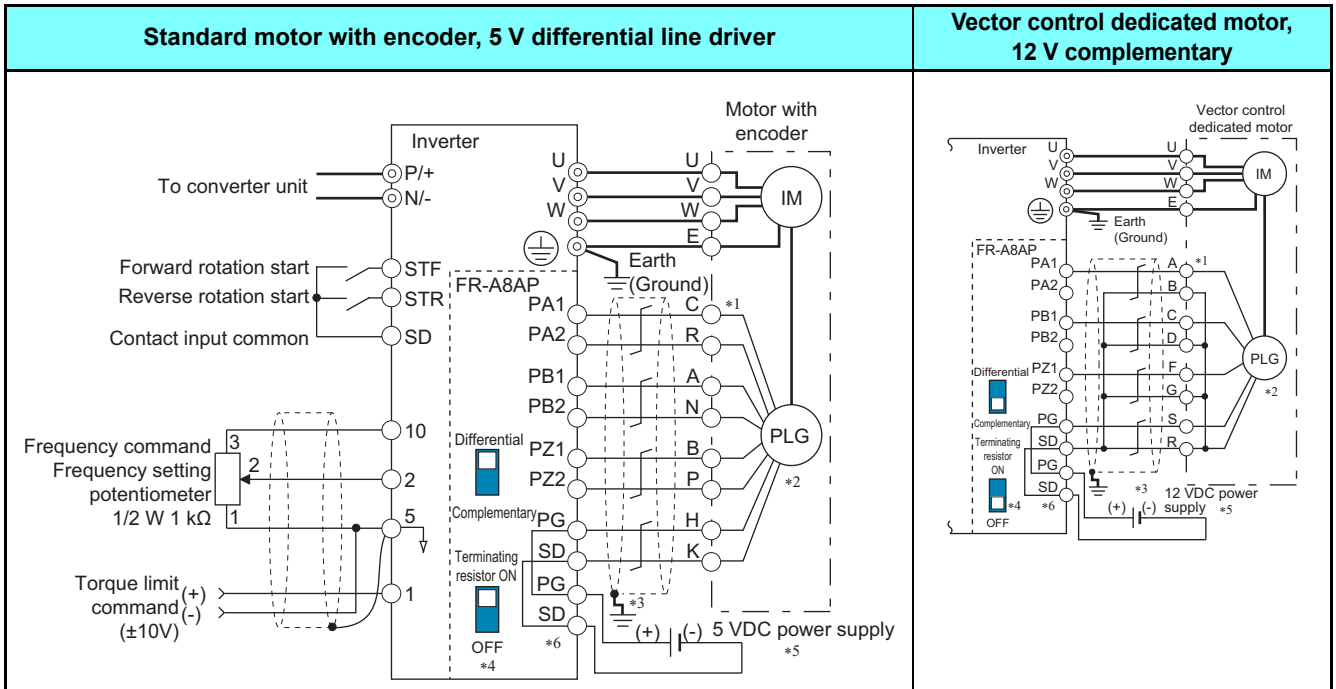

- Torque control

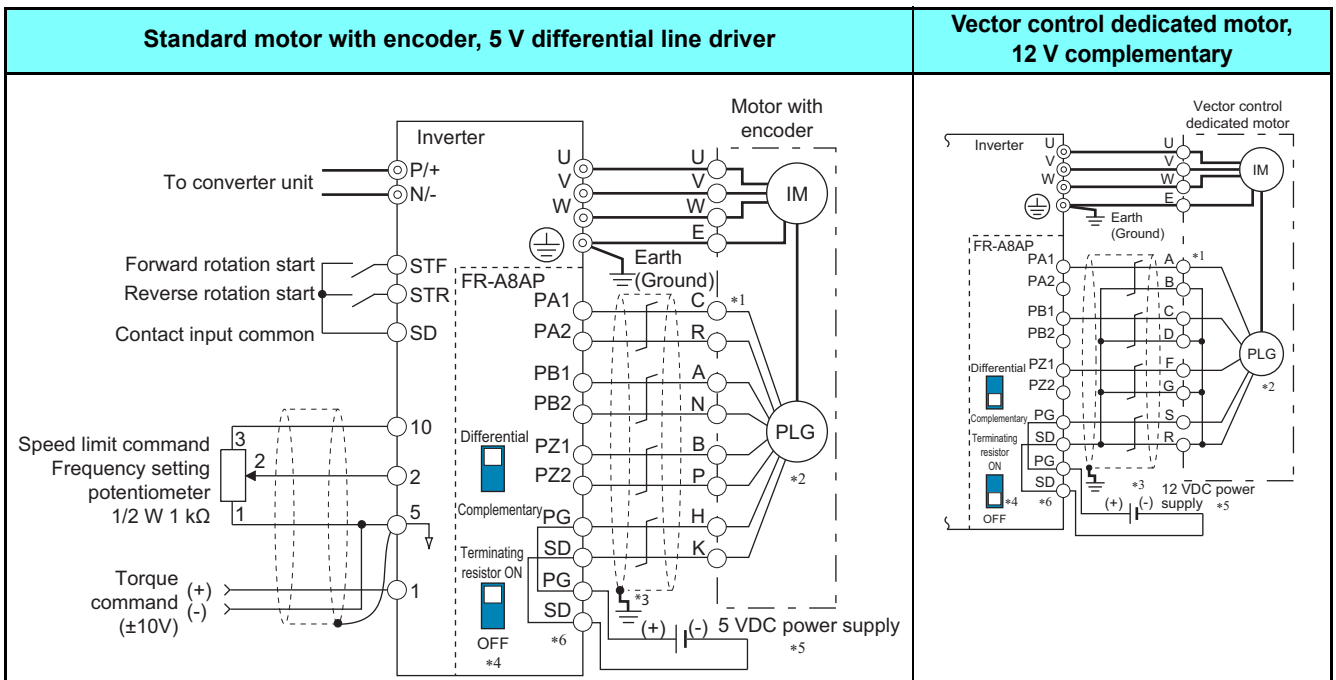

Connection of motor with encoder (vector control)

- Position control

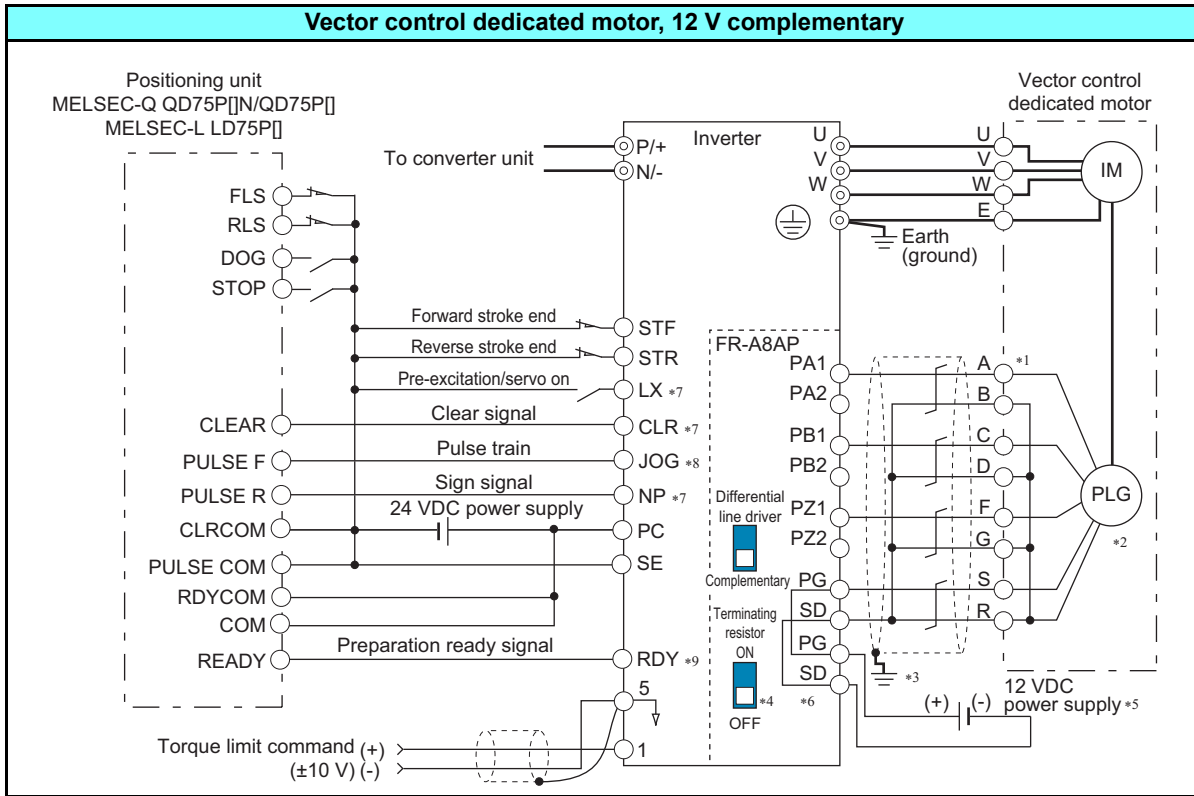

- *1 The pin number differs according to the encoder used. Speed, control, torque control, and position control by pulse train input are available with or without the Z-phase being connected.
- *2 Connect the encoder so that there is no looseness between the motor and motor shaft. Speed ratio must be 1:1.
- *3 Earth (ground) the shield of the encoder cable to the enclosure using a tool such as a P-clip. (Refer to [page 61](#).)
- *4 For the complementary, set the terminating resistor selection switch to OFF position. (Refer to [page 57](#).)
- *5 A separate power supply of 5 V / 12 V / 15 V / 24 V is necessary according to the encoder power specification. When the encoder output is the differential line driver type, only 5 V can be input. Make the voltage of the external power supply the same as the encoder output voltage, and connect the external power supply between PG and SD.
- *6 For terminal compatibility of the FR-JCBL, FR-V7CBL, and FR-A8AP, refer to [page 59](#).
- *7 Assign the function using [Pr.178 to Pr.184](#), [Pr.187 to Pr.189](#) (input terminal function selection).
- *8 When position control is selected, terminal JOG function is invalid and simple position pulse train input terminal becomes valid.
- *9 Assign the function using [Pr.190 to Pr.194](#) (output terminal function selection).

◆ Instructions for encoder cable wiring

- Use shielded twisted pair cables (0.2 mm² or larger) to connect the FR-A8AP. For the wiring to the terminals PG and SD, use several cables in parallel or use a thick cable, according to the wiring length.

To protect the cables from noise, run them away from any source of noise (such as the main circuit and power supply voltage).

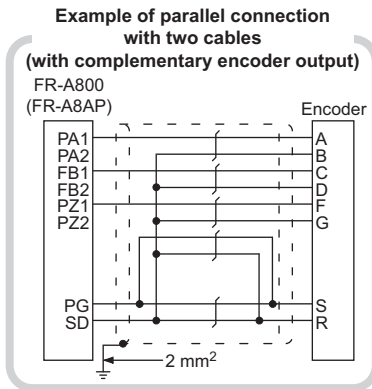

Wiring length	Parallel connection	Larger-size cable
Within 10 m	At least two cables in parallel	Cable gauge 0.2 mm ²
Within 20 m	At least four cables in parallel	
Within 100 m*1	At least six cables in parallel	0.75 mm ² or larger
		1.25 mm ² or larger

*1 When differential line driver is set and a wiring length is 30 m or more.

The wiring length can be extended to 100 m by increasing the 5 V power supply (approximately to 5.5 V) while using six or more 0.2 mm² gauge cables in parallel or a 1.25 mm² or larger gauge cable. The voltage applied must be within power supply specifications of encoder.

- To reduce noise of the encoder cable, earth (ground) the encoder's shielded cable to the enclosure (as close as possible to the inverter) with a P-clip or U-clip made of metal.

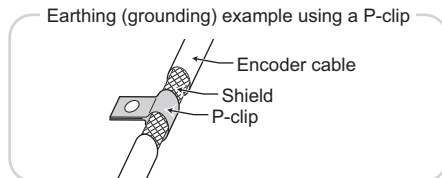

- When one encoder is shared between FR-A8AP and CNC (computerized numerical controller), its output signal should be connected as shown below. In this case, the wiring length between FR-A8AP and CNC should be as short as possible, within 5 m.

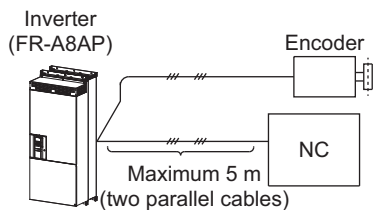

NOTE

- For the details of the optional encoder dedicated cable (FR-JCBL/FR-V7CBL), refer to [page 58](#).
- The FR-V7CBL is provided with a P-clip for earthing (grounding) shielded cables.

2.9 Parameter settings for a motor with encoder

◆ Parameter for the encoder (Pr.359, Pr.369, Pr.851, Pr.852)

- Set the encoder specifications.

Pr.	Name	Initial value	Setting range	Description		
359 C141	852 C241	Encoder rotation direction	1	0	Set when using a motor for which forward rotation (encoder) is clockwise (CW) viewed from the shaft.	Set for the operation at 120 Hz or less.
				100	Set for the operation at a frequency higher than 120 Hz.	
				1	Set when using a motor for which forward rotation (encoder) is counterclockwise (CCW) viewed from the shaft.	Set for the operation at 120 Hz or less.
				101	Set for the operation at a frequency higher than 120 Hz.	
369 C140	851 C240	Number of encoder pulses	1024	0 to 4096	Set the number of encoder pulses output. Set the number of pulses before it is multiplied by 4.	

The parameters above can be set when a vector control compatible option is installed.

- The following table shows parameters to be set according to a vector control compatible option to be used.

Item	FR-A8AP/FR-A8AL/ FR-A8APA parameter	FR-A8APR parameter	FR-A8APS parameter	FR-A8TP parameter
Encoder/Resolver rotation direction	Pr.359			Pr.852
Number of detector pulses	Pr.369	— (fixed 1024 pulses)	— (Obtained via communication from the encoder)	Pr.851

◆ Parameter settings for the motor under vector control

Motor name	Pr.9 Electronic thermal O/L relay	Pr.71 Applied motor	Pr.80 Motor capacity	Pr.81 Number of motor poles	Pr.359/Pr.852 Encoder rotation direction	Pr.369/Pr.851 Number of encoder pulses
Standard motor	Rated motor current	0 (3) *1	Motor capacity	Number of motor poles	*2	*2
Constant-torque motor	Rated motor current	1 (13) *1	Motor capacity	Number of motor poles	*2	*2

*1 Offline auto tuning is required (Refer to the FR-A800 Instruction Manual (Detailed))

*2 Set this parameter according to the motor.

2.10 Connection of stand-alone option units

The inverter accepts a variety of stand-alone option units as required.

Incorrect connection will cause inverter damage or accident. Connect and operate the option unit carefully in accordance with the corresponding option unit manual.

2.10.1 Connection of the brake unit (FR-BU2)

Connect the brake unit (FR-BU2) as shown below to improve the braking capability during deceleration.

After making sure that the wiring is correct and secure, set "11 or 111" in **Pr.30 Regenerative function selection**.

Set **Pr.0 Brake mode selection** = "2" in the brake unit FR-BU2.

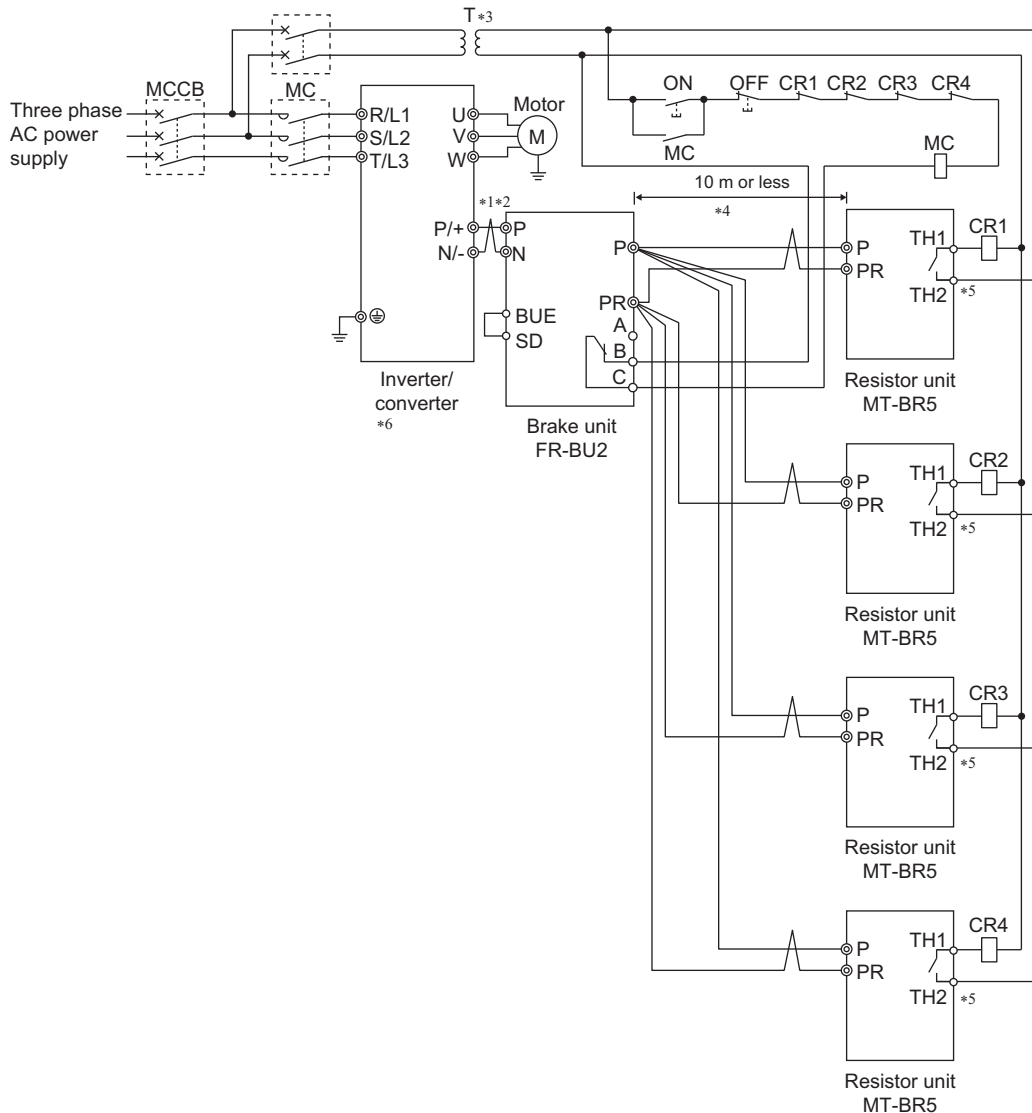

- *1 When wiring, make sure to match the terminal symbol (P/+, N/-) at the inverter side and at the brake unit (FR-BU2) side. (Incorrect connection will damage the inverter and brake unit.)
- *2 For the FR-A842-08660(355K) or lower, up to two cables can be connected to terminals P/+ and N/-. For the FR-A842-09620(400K) or higher, up to four cables can be connected. To use more cables, use a bus bar.
- *3 When the power supply is 400 V class, install a stepdown transformer.
- *4 The wiring distance between the inverter, brake unit (FR-BU2) and resistor unit (MT-BR5) must be within 5 m each. Even when the cable is twisted, the wiring length must be within 10 m.
- *5 The contact between TH1 and TH2 is open in the normal status and is closed at a fault.
- *6 The CN8 connector used with the MT-BU5 type brake unit is not used.

NOTE

- The warning "oL" of the stall prevention (overvoltage) is disabled while **Pr.30 Regenerative function selection** = "11 or 111".
- For the parameter details, refer to the FR-A800 Instruction Manual (Detailed).

2.10.2 Connection of the high power factor converter (FR-HC2)

When connecting the high power factor converter (FR-HC2) to suppress power harmonics, perform wiring securely as shown below. Incorrect connection will damage the high power factor converter and the inverter.

After making sure that the wiring is correct and secure, set the rated motor voltage in **Pr.19 Base frequency voltage** (under V/F control) or **Pr.83 Rated motor voltage** (under other than V/F control) and "2 or 102" in **Pr.30 Regenerative function selection**.

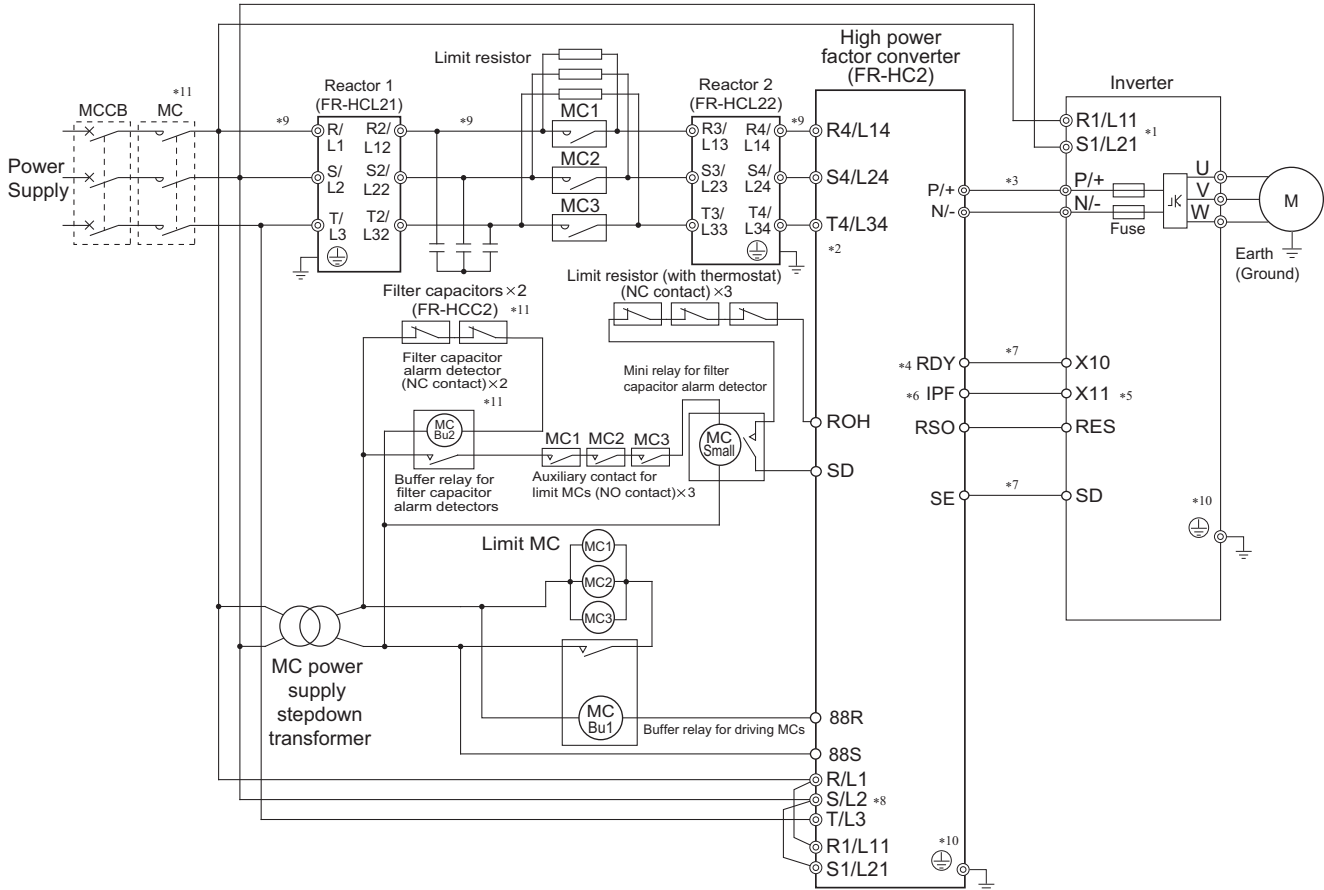

- *1 Remove jumpers installed in terminals R1/L11 and S1/L21 of the inverter, and connect the power supply for the control circuit to terminals R1/L11 and S1/L21.
- *2 The voltage phases of terminals R4/L14, S4/L24, and T4/L34 and the voltage phases of terminals R/L1, S/L2, and T/L3 must be matched.
- *3 Do not install an MCCB across the terminals P/+ and N/- (across terminals P and P/+ or across N and N/-). Connecting the opposite polarity of terminals N/- and P/+ will damage the inverter.
When using the FR-HC2 with the FR-A802 series, installation of a fuse is not required.
- *4 Change the FR-HC2 parameter setting to **Pr.10 RDY signal logic selection** = "0" (positive logic).
- *5 Use **Pr.178 to Pr.189 (input terminal function selection)** to assign the terminals used for the X10 signal.
For RS-485 or any other communication where the start command is only transmitted once, use the X11 signal to save the operation mode at the time of an instantaneous power failure.
- *6 Assign the IPF signal to an FR-HC2 terminal. (Refer to the Instruction Manual of FR-HC2.)
- *7 Always connect the FR-HC2 terminal RDY to the inverter terminal MRS(X10), and the FR-HC2 terminal SE to the inverter terminal SD. Not connecting these terminals may damage the FR-HC2.
- *8 Always connect the R/L1, S/L2, and T/L3 terminals of FR-HC2 to the power supply. Operating the inverter without connecting them will damage the FR-HC2.
- *9 Do not install an MCCB or MC between the reactor 1 terminals (R/L1, S/L2, T/L3) and the FR-HC2 terminals (R4/L14, S4/L24, T4/L34). It will not operate properly.
- *10 Securely perform grounding (earthing) by using the grounding (earthing) terminal.
- *11 The number of connected peripheral devices differs according to the capacity. For the detail, refer to the FR-HC2 Instruction Manual.

NOTE

- The voltage phases of terminals R/L1, S/L2, and T/L3 and the voltage phases of terminals R4/L14, S4/L24, and T4/L34 must be matched.
- The control logic (sink logic/source logic) of the high power factor converter and the inverter must be matched. (Refer to [page 41](#).)
- When using a sine wave filter with FR-HC2, select MT-BSL-HC as a reactor for the sine wave filter.
- For the parameter details, refer to the FR-A800 Instruction Manual (Detailed).

2.10.3 Connection of the power regeneration converter (MT-RC)

When connecting the power regeneration converter (MT-RC), perform wiring securely as follows. Incorrect connection will damage the power regeneration converter and the inverter. After making sure that the wiring is correct and secure, set "1 or 101" in **Pr.30 Regenerative function selection**.

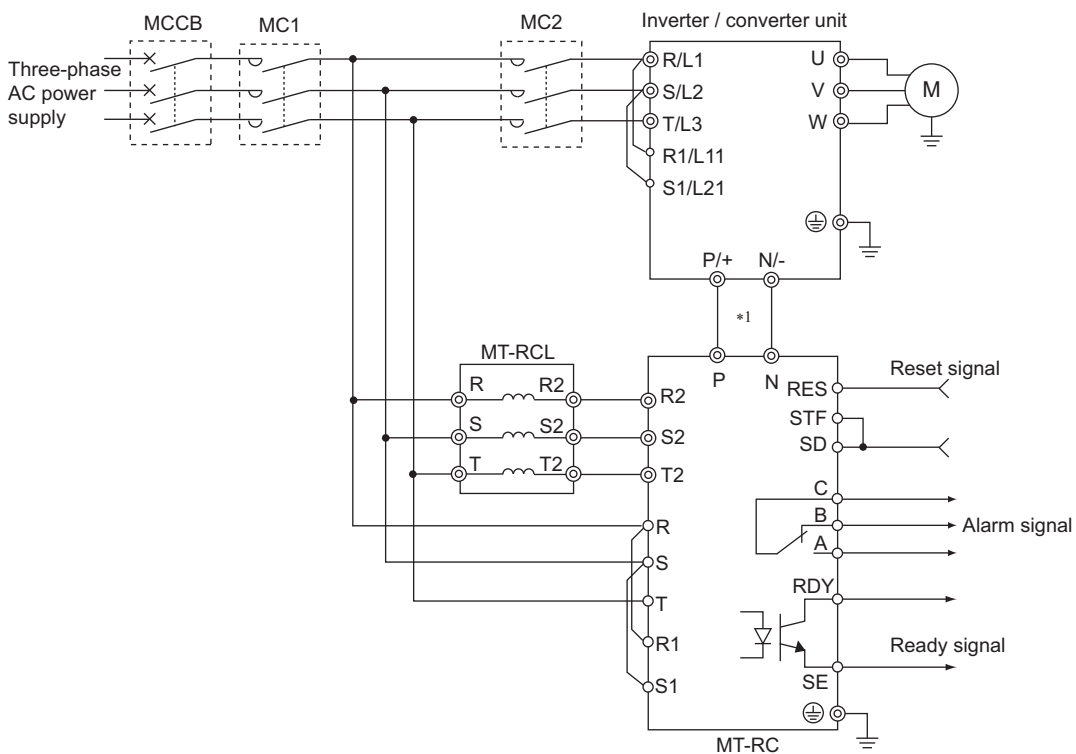

*1 For the FR-A842-08660(355K) or lower, up to two cables can be connected to terminals P/+ and N/-. For the FR-A842-09620(400K) or higher, up to four cables can be connected. To use more cables, use a bus bar.

NOTE

- When using the inverter with the MT-RC, install a magnetic contactor (MC) at the input side of the inverter so that power is supplied to the inverter after one second or more has elapsed after powering ON the MT-RC. When power is supplied to the inverter prior to the MT-RC, the inverter and the MT-RC may be damaged or the MCCB may be shut off or damaged.

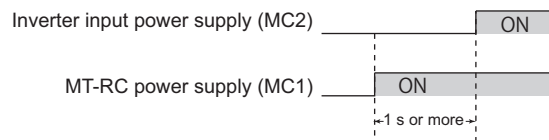

- When connecting the power coordination reactor and others, refer to Instruction Manual of the MT-RC for precautions.

MEMO

3 PRECAUTIONS FOR USE OF THE INVERTER

This chapter explains the precautions for use of this product.
Always read the instructions before using the equipment.

3.1	Electro-magnetic interference (EMI) and leakage currents ..	68
3.2	Power supply harmonics	75
3.3	Installation of a reactor	78
3.4	Power-OFF and magnetic contactor (MC)	79
3.5	Countermeasures against deterioration of the 400 V class motor insulation.....	80
3.6	Checklist before starting operation	81
3.7	Failsafe system which uses the inverter	84

3.1 Electro-magnetic interference (EMI) and leakage currents

3.1.1 Leakage currents and countermeasures

Capacitances exist between the inverter I/O cables, other cables and earth and in the motor, through which a leakage current flows. Since its value depends on the static capacitances, carrier frequency, etc., low acoustic noise operation at the increased carrier frequency of the inverter will increase the leakage current. Therefore, take the following countermeasures. Select the earth leakage current breaker according to its rated sensitivity current, independently of the carrier frequency setting.

◆ To-earth (ground) leakage currents

Leakage currents may flow not only into the inverter's own line but also into the other lines through the earthing (grounding) cable, etc. These leakage currents may operate earth leakage circuit breakers and earth leakage relays unnecessarily.

● Countermeasures

- If the carrier frequency setting is high, decrease the **Pr.72 PWM frequency selection** setting.
Note that motor noise increases. Selecting **Pr.240 Soft-PWM operation selection** makes the sound inoffensive.
- By using earth leakage circuit breakers designed for harmonic and surge suppression in the inverter's own line and other line, operation can be performed with the carrier frequency kept high (with low noise).

● To-earth (ground) leakage currents

- Take caution as long wiring will increase the leakage current. Decreasing the carrier frequency of the inverter reduces the leakage current.
- Increasing the motor capacity increases the leakage current.

◆ Line-to-line leakage currents

Harmonics of leakage currents flowing in static capacitances between the inverter output cables may operate the external thermal relay unnecessarily.

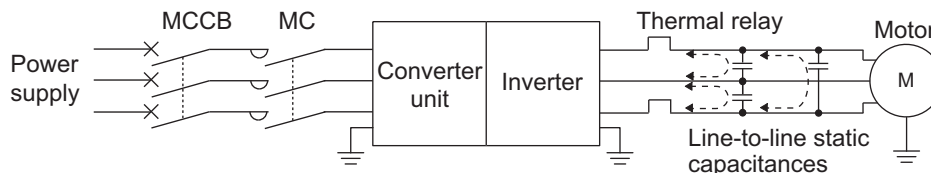

Line-to-line leakage currents path

● Countermeasures

- Use **Pr.9 Electronic thermal O/L relay**.
- If the carrier frequency setting is high, decrease the **Pr.72 PWM frequency selection** setting.
Note that motor noise increases. Selecting **Pr.240 Soft-PWM operation selection** makes the sound inoffensive.
To ensure that the motor is protected against line-to-line leakage currents, it is recommended to use a temperature sensor to directly detect motor temperature.

● Installation and selection of the molded case circuit breaker

Install a molded case circuit breaker (MCCB) on the power receiving side to protect the wiring at the inverter input side. Select an MCCB according to the inverter input side power factor, which depends on the power supply voltage, output frequency and load. Especially for a completely electromagnetic MCCB, a slightly large capacity must be selected since its operation characteristic varies with harmonic currents. (Check it in the data of the corresponding breaker.) As an earth leakage current breaker, use the Mitsubishi earth leakage current breaker designed for harmonics and surge suppression.

◆ Selecting the rated sensitivity current for the earth leakage circuit breaker

When using an earth leakage circuit breaker with the inverter circuit, select its rated sensitivity current as follows, independently of the PWM carrier frequency.

- Breaker designed for harmonic and surge suppression
Rated sensitivity current
 $I_{\Delta n} \geq 10 \times (I_{g1} + I_{gn} + I_{gi} + I_{g2} + I_{gm})$
 - Standard breaker
Rated sensitivity current
 $I_{\Delta n} \geq 10 \times \{I_{g1} + I_{gn} + I_{gi} + 3 \times (I_{g2} + I_{gm})\}$
- I_{g1}, I_{g2} : Leakage currents in wire path during commercial power supply operation
 I_{gn} : Leakage current of inverter input side noise filter
 I_{gm} : Leakage current of motor during commercial power supply operation
 I_{gi} : Leakage current of inverter unit
 (When the converter unit is connected, add the leakage current of converter unit.)

Example of leakage current per 1km during the commercial power supply operation when the CV cable is routed in metal conduit

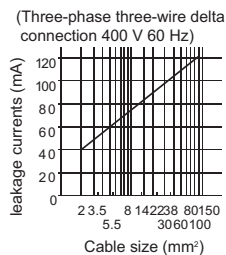

Leakage current example of three-phase induction motor during the commercial power supply operation

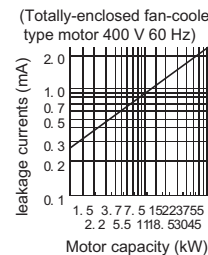

For "Δ" connection, the amount of leakage current is approx. 1/3 of the above value.

<Example>

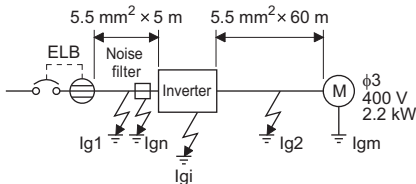

- Selection example for the Δ connection of the 400 V class

Item	Breaker designed for harmonic and surge suppression	Standard breaker
Leakage current I_{g1} (mA)	$\frac{1}{3} \times 66 \times \frac{5 \text{ m}}{1000 \text{ m}} = 0.11$	
Leakage current I_{gn} (mA)	0 (without noise filter)	
Leakage current I_{gi} (mA)	1 (without EMC filter) For the leakage current of the inverter, refer to the following table.	
Leakage current I_{g2} (mA)	$\frac{1}{3} \times 66 \times \frac{60 \text{ m}}{1000 \text{ m}} = 1.32$	
Motor leakage current I_{gm} (mA)	0.36	
Total leakage current (mA)	2.79	6.15
Rated sensitivity current (mA) ($\geq I_g \times 10$)	30	100

- Inverter/converter unit leakage current

400 V class (input power condition: 440 V/60 Hz, power supply unbalance within 3%)

Inverter/ converter unit	FR-A800 (Standard model)		FR-A802 (Separated converter type)	Converter unit FR-CC2	
	ON	OFF		ON	OFF
Phase earthing (grounding)	35	2	2	70	2
Earthed-neutral system	2	1	1	2	1

(mA)

NOTE

- Install the earth leakage circuit breaker (ELB) on the input side of the converter unit.
- In the Δ connection earthed-neutral system, the sensitivity current is blunt against a ground fault in the inverter output side. Earthing (Grounding) must conform to the requirements of national and local safety regulations and electrical codes. (NEC section 250, IEC 61140 class 1 and other applicable standards)
- When the breaker is installed on the output side of the inverter, it may be unnecessarily operated by harmonics even if the effective value is within the rating.
In this case, do not install the breaker since the eddy current and hysteresis loss will increase, leading to temperature rise.
- The following models are standard breakers BV-C1, BC-V, NVB, NV-L, NV-G2N, NV-G3NA, NV-2F, earth leakage relay (except NV-ZHA), and NV with AA neutral wire open-phase protection.
The other models are designed for harmonic and surge suppression: NV-C/NV-S/MN series, NV30-FA, NV50-FA, BV-C2, earth leakage alarm breaker (NF-Z), NV-ZHA, and NV-H.
- For the leakage current of a 75 kW or higher motor, contact the motor manufacturer.

3.1.2 Countermeasures against inverter-generated EMI

Some electromagnetic noises enter the inverter or the converter unit to cause its malfunction, and others are radiated by the inverter or the converter unit to cause the peripheral devices to malfunction. Though the inverter or the converter unit is designed to have high immunity performance, it handles low-level signals, so it requires the following basic techniques. Also, since the inverter chops outputs at high carrier frequency, that could generate electromagnetic noises. If these electromagnetic noises cause peripheral devices to malfunction, EMI countermeasures should be taken to suppress noises. These techniques differ slightly depending on EMI paths.

- Basic techniques
 - Do not run the power cables (I/O cables) and signal cables of the inverter or the converter unit in parallel with each other and do not bundle them.
 - Use shielded twisted pair cables for the detector connecting and control signal cables and connect the sheathes of the shielded cables to terminal SD.
 - Ground (Earth) the inverter or the converter unit, motor, etc. at one point.

- Techniques to reduce electromagnetic noises that enter and cause a malfunction of the inverter or the converter unit (EMI countermeasures)

When devices that generate many electromagnetic noises (which use magnetic contactors, electromagnetic brakes, many relays, for example) are installed near the inverter or the converter unit and it may malfunction due to electromagnetic noises, the following countermeasures must be taken:

- Provide surge suppressors for devices that generate many electromagnetic noises to suppress electromagnetic noises.
- Install data line filters (page 72) to signal cables.
- Ground (Earth) the shields of the detector connection and control signal cables with cable clamp metal.

- Techniques to reduce electromagnetic noises that are radiated by the inverter to or converter unit cause the peripheral devices to malfunction (EMI countermeasures)

Noises generated from the inverter or the converter unit are largely classified into those radiated by the cables connected to the inverter or the converter unit and its main circuits (I/O), those electromagnetically and electrostatically induced to the signal cables of the peripheral devices close to the main circuit power supply, and those transmitted through the power supply cables.

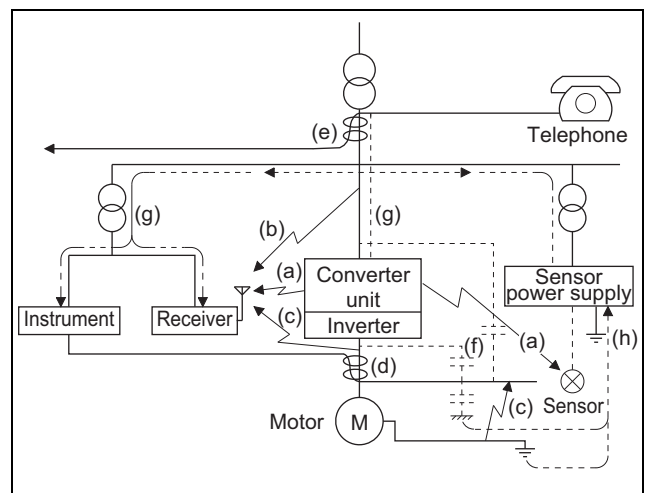
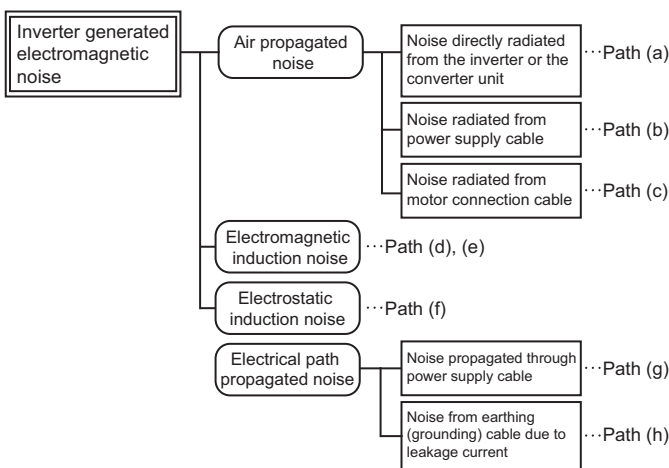

Electro-magnetic interference (EMI) and leakage currents

Noise propagation path	Countermeasure
(a)(b)(c)	<p>When devices that handle low-level signals and are liable to malfunction due to electromagnetic noises, e.g. instruments, receivers and sensors, are contained in the enclosure that contains the inverter or the converter unit, or when their signal cables are run near the inverter, the devices may malfunction due to by air-propagated electromagnetic noises. The following countermeasures must be taken:</p> <ul style="list-style-type: none"> • Install easily affected devices as far away as possible from the inverter or the converter unit. • Run easily affected signal cables as far away as possible from the inverter or the converter unit, and its I/O cables. • Do not run the signal cables and power cables (inverter or converter unit I/O cables) in parallel with each other and do not bundle them. • Set the EMC filter ON/OFF connector of the converter unit to the ON position. (Refer to page 74.) • Inserting a line noise filter into the output suppresses the radiated noise from the cables. • Use shielded cables as signal cables and power cables and run them in individual metal conduits to produce further effects.
(d)(e)(f)	<p>When the signal cables are run in parallel with or bundled with the power cables, magnetic and static induction noises may be propagated to the signal cables to cause malfunction of the devices and the following countermeasures must be taken:</p> <ul style="list-style-type: none"> • Install easily affected devices as far away as possible from the inverter or the converter unit. • Run easily affected signal cables as far away as possible from the inverter or the converter unit, and its I/O cables. • Do not run the signal cables and power cables (inverter or converter unit I/O cables) in parallel with each other and do not bundle them. • Use shielded cables as signal cables and power cables and run them in individual metal conduits to produce further effects.
(g)	<p>When the power supplies of the peripheral devices are connected to the power supply of the inverter or the converter unit in the same line, its generated noises may flow back through the power supply cables to cause malfunction of the devices and the following countermeasures must be taken:</p> <ul style="list-style-type: none"> • Set the EMC filter ON/OFF connector of the converter unit to the ON position. (Refer to page 74.) • Install the line noise filter to the power cables (output cables) of the inverter.
(h)	<p>When a closed loop circuit is formed by connecting the peripheral device wiring to the inverter or the converter unit, leakage currents may flow through the earthing (grounding) cable of the inverter or the converter unit to cause the device to malfunction. In that case, disconnecting the earthing (grounding) cable from the device may stop the malfunction of the device.</p>

●Data line filter

Data line filter is effective as an EMI countermeasure. Provide a data line filter for the detector cable, etc.

<Example> Data line filter: ZCAT3035-1330 (by TDK)

ESD-SR-250 (by NEC TOKIN)

Impedance (ZCAT3035-1330)

Impedance (Ω)	
10 to 100 MHz	100 to 500 MHz
80	150

The impedance values above are reference values, and not guaranteed values.

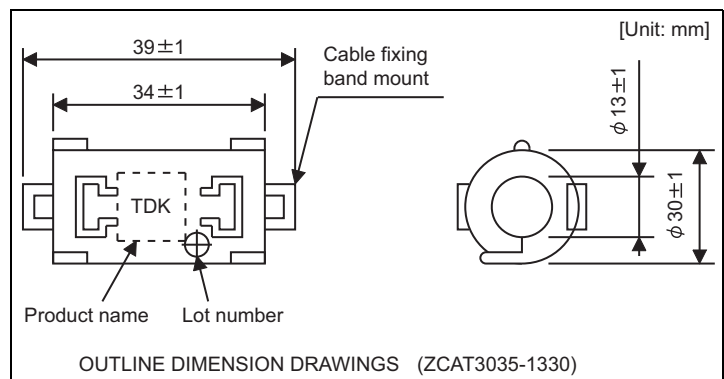

●EMI countermeasure example

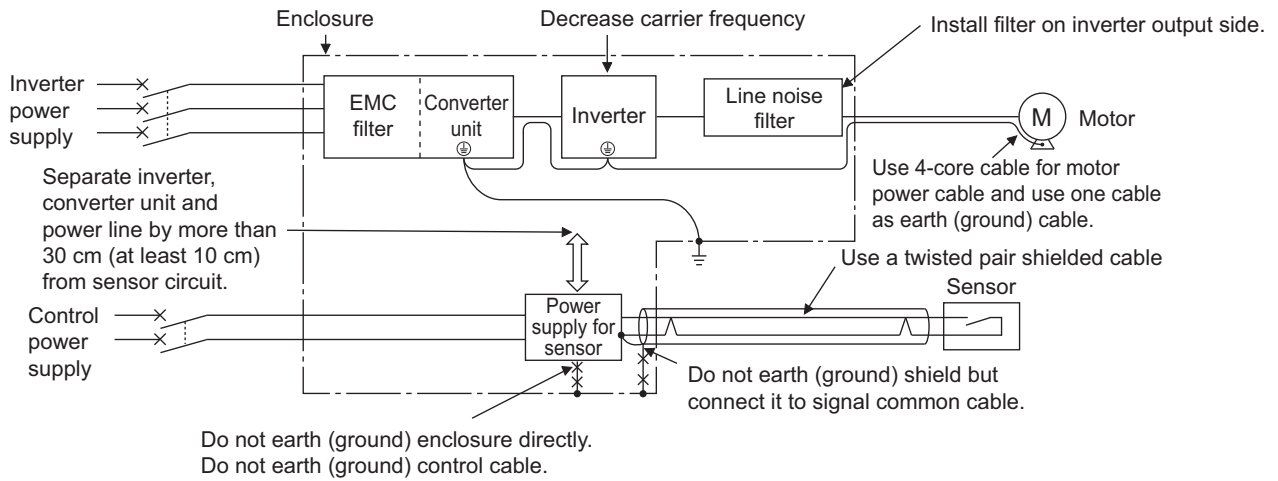

NOTE

- For compliance with the EU EMC Directive, refer to [page 115](#).

3.1.3 Converter unit (FR-CC2) built-in EMC filter

The converter unit (FR-CC2) is equipped with a built-in EMC filter (capacitive filter).
 These filters are effective in reducing air-propagated noise on the input side of the converter unit.
 To enable the EMC filter, fit the EMC filter ON/OFF connector to the ON position.
 Both of two EMC filter ON/OFF connectors are initially set to the OFF position (disabled).
 To enable the EMC filter, fit both of the EMC filter ON/OFF connectors to the ON position.

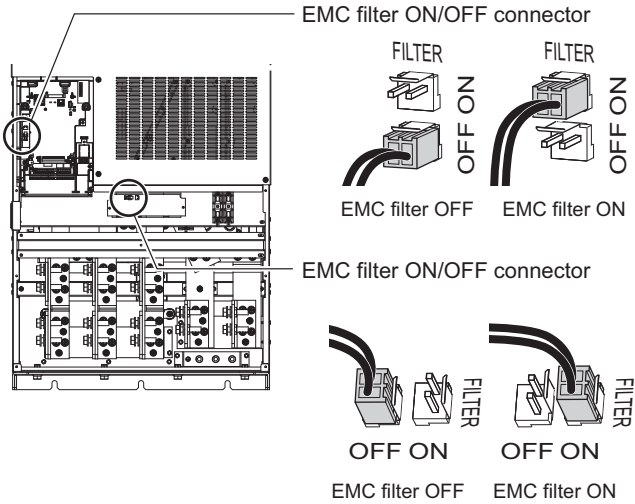

<How to enable or disable the filter>

- Before removing a front cover, check to make sure that the indication of the inverter operation panel is OFF, wait for at least 10 minutes after the power supply has been switched OFF, and check that there is no residual voltage using a tester or the like.
- When disconnecting the connector, push the fixing tab and pull the connector straight without pulling the cable or forcibly pulling the connector with the tab fixed.
 When installing the connector, also engage the fixing tab securely.
 (If it is difficult to disconnect the connector, use a pair of needle-nose pliers, etc.)

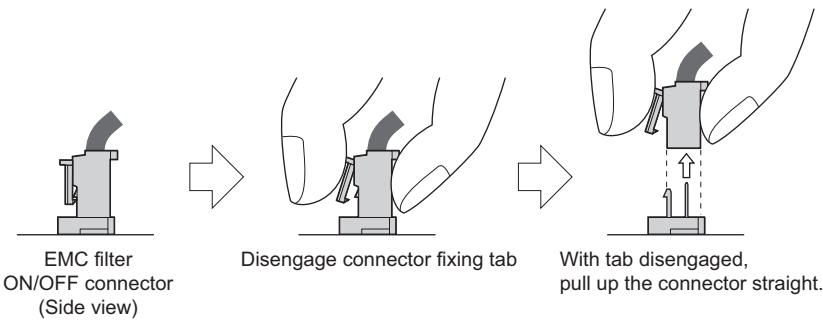

NOTE

- Fit the connector to either ON or OFF position.
- Enabling (turning ON) the EMC filter increases leakage current. (Refer to [page 69](#).)

! WARNING

- While the inverter power is ON, do not open the front cover. Otherwise you may get an electric shock.

3.2 Power supply harmonics

3.2.1 Power supply harmonics

The inverter may generate power supply harmonics from its converter circuit to affect the power generator, power factor correction capacitor etc. Power supply harmonics are different from noise and leakage currents in source, frequency band and transmission path. Take the following countermeasure suppression techniques.

- The differences between harmonics and noises

Item	Harmonics	Noise
Frequency	Normally 40th to 50th degrees or less (3 kHz or less).	High frequency (several 10 kHz to 1 GHz order).
Environment	To-electric channel, power impedance.	To-space, distance, wiring path,
Quantitative understanding	Theoretical calculation possible.	Random occurrence, quantitative grasping difficult.
Generated amount	Nearly proportional to the load capacity.	Changes with the current variation ratio. (Gets larger as switching speed increases.)
Affected equipment immunity	Specified by standards per equipment.	Different depending on maker's equipment specifications.
Countermeasure	Provide a reactor.	Increase distance.

- Countermeasures

The harmonic current generated from the inverter to the input side differs according to various conditions such as the wiring impedance, whether a reactor is used or not, and output frequency and output current on the load side.

For the output frequency and output current, we understand that this should be calculated in the conditions under the rated load at the maximum operating frequency.

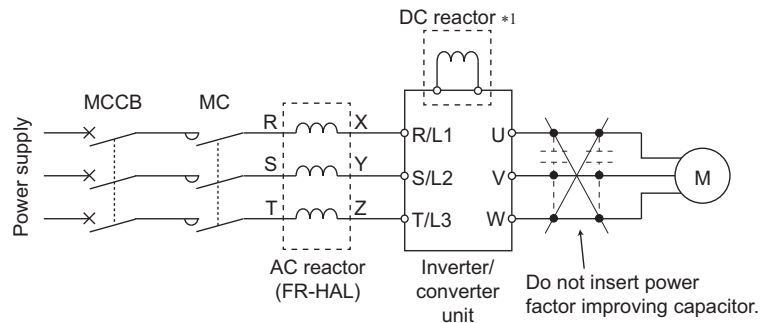

*1 The converter unit (FR-CC2) is equipped with the DC reactor.

NOTE

- The power factor improving capacitor and surge suppressor on the inverter output side may be overheated or damaged by the harmonic components of the inverter output. Also, since an excessive current flows in the inverter to activate overcurrent protection, do not provide a capacitor and surge suppressor on the inverter output side when the motor is driven by the inverter. For power factor improvement, install a reactor on the inverter input side or in the DC circuit.

3.2.2 Harmonic Suppression Guidelines in Japan

Inverters have a converter section (rectifier circuit) and generate a harmonic current.

Harmonic currents flow from the inverter to a power receiving point via a power transformer. The Harmonic Suppression Guidelines was established to protect other consumers from these outgoing harmonic currents.

The three-phase 200 V input specifications 3.7 kW or lower were previously covered by "the Harmonic Suppression Guidelines for Household Appliances and General-purpose Products" and other models were covered by "the Harmonic Suppression Guidelines for Consumers Who Receive High Voltage or Special High Voltage". However, the transistorized inverter has been excluded from the target products covered by "the Harmonic Suppression Guidelines for Household Appliances and General-purpose Products" in January 2004 and "the Harmonic Suppression Guideline for Household Appliances and General-purpose Products" was repealed on September 6, 2004. All capacity and all models of general-purpose inverter used by specific consumers are now covered by "the Harmonic Suppression Guidelines for Consumers Who Receive High Voltage or Special High Voltage" (hereinafter referred to as "the Specific Consumer Guidelines").

- "Specific Consumer Guidelines"

This guideline sets forth the maximum harmonic currents outgoing from a high-voltage or especially high-voltage receiving consumer who will install, add or renew harmonic generating equipment. If any of the maximum values is exceeded, this guideline requires that consumer to take certain suppression measures.

- Maximum Values of Outgoing Harmonic Currents per 1 kW Contract Power

Received power voltage	5th	7th	11th	13th	17th	19th	23rd	Over 23rd
6.6 kV	3.5	2.5	1.6	1.3	1.0	0.9	0.76	0.70
22 kV	1.8	1.3	0.82	0.69	0.53	0.47	0.39	0.36
33 kV	1.2	0.86	0.55	0.46	0.35	0.32	0.26	0.24

◆ Application of the specific consumer guidelines

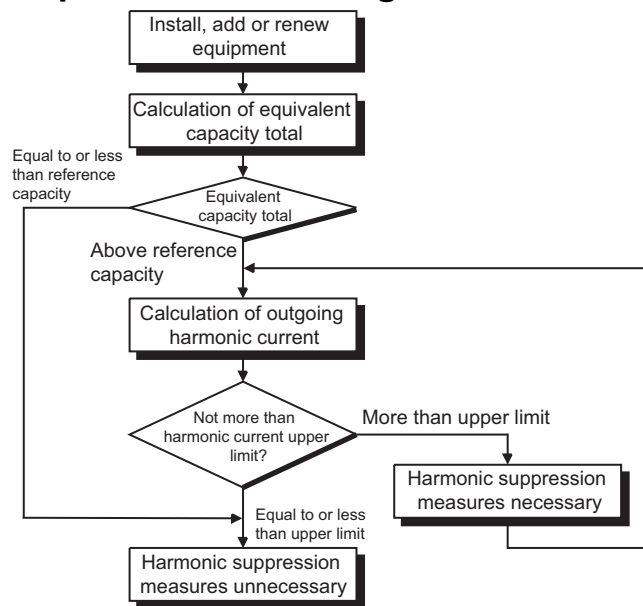

- Conversion factors

Classification	Circuit type		Conversion coefficient Ki
3	Three-phase bridge (Capacitor smoothing)	With reactor (DC side)	K33 = 1.8
		With reactors (AC, DC sides)	K34 = 1.4
5	Self-excitation three-phase bridge	When a high power factor converter is used	K5 = 0

- Equivalent Capacity Limits

Received power voltage	Reference capacity
6.6 kV	50 kVA
22/33 kV	300 kVA
66 kV or more	2000 kVA

- Harmonic content (Values of the fundamental current is 100%)

reactor	5th	7th	11th	13th	17th	19th	23rd	25th
Used (DC side)	30	13	8.4	5.0	4.7	3.2	3.0	2.2
Used (AC, DC sides)	28	9.1	7.2	4.1	3.2	2.4	1.6	1.4

- Calculation of equivalent capacity P0 of harmonic generating equipment

"Equivalent capacity" is the capacity of a 6-pulse converter converted from the capacity of consumer's harmonic generating equipment and is calculated by the following equation: If the sum of equivalent capacities is higher than the limit in (refer to [page 76](#)), harmonics must be calculated with the following procedure:

$$P0 = \sum (Ki \times Pi) \text{ [kVA]}$$

Ki: Conversion coefficient (Refer to [page 76](#))

Pi: Rated capacity*1 of harmonic generating equipment [kVA]

i: Number indicating the conversion circuit type

*1 Rated capacity: Determined by the capacity of the applied motor and found in Table 5. The rated capacity used here is used to calculate the generated harmonic amount and is different from the power supply capacity required for actual inverter drive.

- Calculation of outgoing harmonic current

Outgoing harmonic current = fundamental wave current (value converted from received power voltage) × operation ratio × harmonic content

- Operation ratio: Operation ratio = actual load factor × operation time ratio during 30 minutes
- Harmonic content: Found in [page 76](#).

- Rated capacities and outgoing harmonic currents of inverter-driven motors

Applicable motor (kW)	Fundamental wave current (A)	Fundamental wave current converted from 6.6 kV (mA)	Rated capacity (kVA)	Outgoing harmonic current converted from 6.6 kV (mA) (With a DC reactor, 100% operation ratio)							
	400 V			5th	7th	11th	13th	17th	19th	23rd	25th
75	123	7455	87.2	2237	969	626	373	350	239	224	164
90	147	8909	104	2673	1158	748	445	419	285	267	196
110	179	10848	127	3254	1410	911	542	510	347	325	239
132	216	13091	153	3927	1702	1100	655	615	419	393	288
160	258	15636	183	4691	2033	1313	782	735	500	469	344
220	355	21515	252	6455	2797	1807	1076	1011	688	645	473
250	403	24424	286	7327	3175	2052	1221	1148	782	733	537
280	450	27273	319	8182	3545	2291	1364	1282	873	818	600
315	506	30667	359	9200	3987	2576	1533	1441	981	920	675
355	571	34606	405	10382	4499	2907	1730	1627	1107	1038	761
400	643	38970	456	11691	5066	3274	1949	1832	1247	1169	857
450	723	43818	512	13146	5696	3681	2191	2060	1402	1315	964
500	804	48727	570	14618	6335	4093	2436	2290	1559	1462	1072
560	900	54545	638	16364	7091	4582	2727	2564	1746	1636	1200
630	1013	61394	718	18418	7981	5157	3070	2886	1965	1842	1351

- Determining if a countermeasure is required

A countermeasure for harmonics is required if the following condition is satisfied: outgoing harmonic current > maximum value per 1 kW contract power × contract power.

- Harmonic suppression techniques

No.	Item	Description
1	Reactor installation (FR-HAL)	The converter unit (FR-CC2) is equipped with the DC reactor on its DC side, and outgoing harmonic current can be suppressed. By installing an AC reactor (FR-HAL) on the AC side of the inverter, the outgoing harmonic current suppression performance can be improved.
2	high power factor converter (FR-HC2)	This converter trims the current waveform to be a sine waveform by switching the rectifier circuit (converter module) with transistors. Doing so suppresses the generated harmonic amount significantly. Connect it to the DC area of an inverter. Use the high power factor converter (FR-HC2) with the accessories that come as standard.
3	Installation of power factor improving capacitor	When used with a reactor connected in series, the power factor improving correction capacitor can absorb harmonic currents.
4	Transformer multi-phase operation	Use two transformers with a phase angle difference of 30° as in λ - Δ and Δ - Δ combinations to provide an effect corresponding to 12 pulses, reducing low-degree harmonic currents.
5	Passive filter (AC filter)	A capacitor and a reactor are used together to reduce impedances at specific frequencies. Harmonic currents are expected to be absorbed greatly by using this technique.
6	Active filter	This filter detects the current in a circuit generating a harmonic current and generates a harmonic current equivalent to a difference between that current and a fundamental wave current to suppress the harmonic current at the detection point. Harmonic currents are expected to be absorbed greatly by using this technique.

3.3 Installation of a reactor

When the inverter is connected near a large-capacity power transformer (1000 kVA or more) or when a power factor correction capacitor is to be switched over, an excessive peak current may flow in the power input circuit, damaging the converter circuit. To prevent this, always install an optional AC reactor (FR-HAL).

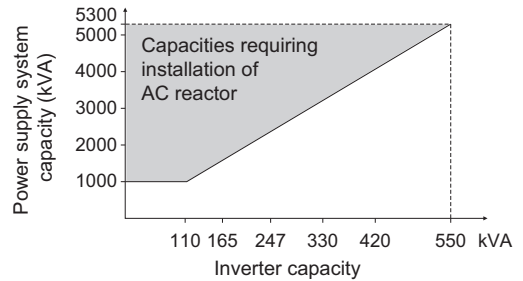
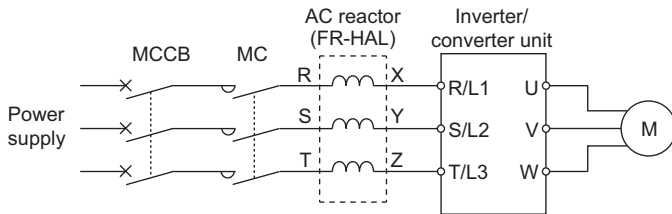

3.4 Power-OFF and magnetic contactor (MC)

◆ Converter unit input side magnetic contactor (MC)

On the converter unit input side, it is recommended to provide an MC for the following purposes:

(Refer to [page 14](#) for selection.)

- To disconnect the inverter from the power supply at activation of a protective function or at malfunctioning of the driving system (emergency stop, etc.).
- To prevent any accident due to an automatic restart at power restoration after an inverter stop made by a power failure.
- To separate the inverter from the power supply to ensure safe maintenance and inspection work.

If using an MC for emergency stop during operation, select an MC regarding the converter unit input side current as JEM 1038-AC-3 class rated current.

NOTE

- Since repeated inrush currents at power ON will shorten the life of the converter circuit (switching life is about 1,000,000 times), frequent starts and stops of the magnetic contactor must be avoided. Turn ON/OFF the inverter start controlling terminals (STF, STR) to run/stop the inverter.

- Inverter start/stop circuit example

As shown below, always use the start signal (ON or OFF of STF (STR) signal) to make a start or stop.

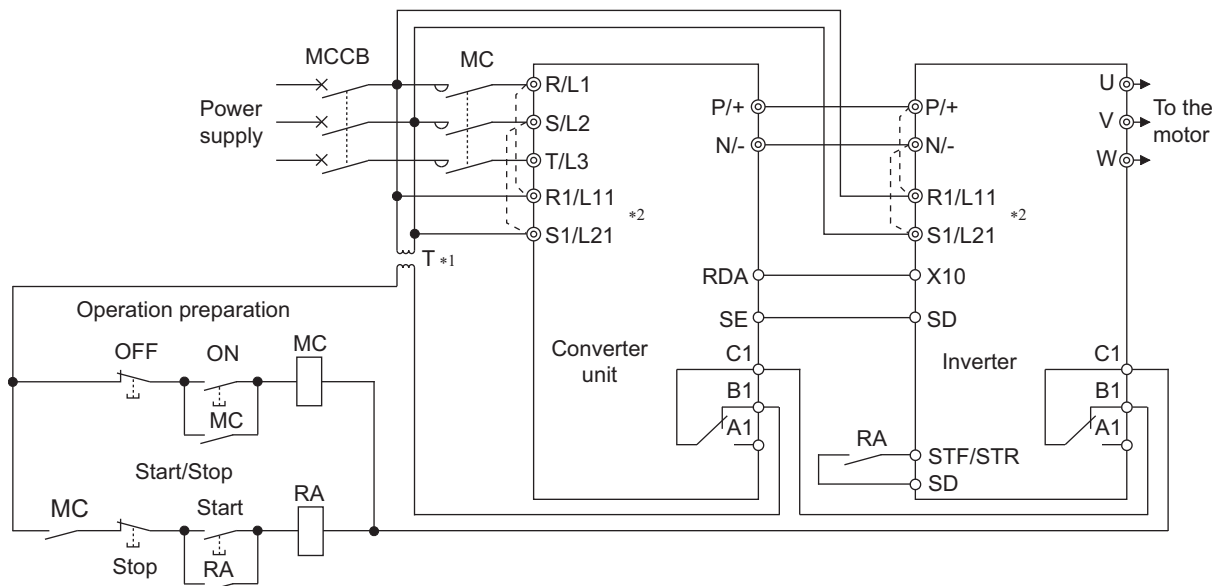

*1 When the power supply is 400 V class, install a stepdown transformer.

*2 Connect the power supply terminals R1/L11, S1/L21 of the control circuit to the input side of the MC to hold an alarm signal when the inverter's protective circuit is activated. At this time, remove jumpers across terminals R1/L11 and S1/L21. (Refer to [page 46](#) for removal of the jumper.)

◆ Handling of the magnetic contactor on the inverter's output side

Switch the magnetic contactor between the inverter and motor only when both the inverter and motor are at a stop. When the magnetic contactor is turned ON while the inverter is operating, overcurrent protection of the inverter and such will activate.

When an MC is provided to switch to a commercial power supply, for example, it is recommended to use the commercial power supply-inverter switchover function **Pr.135 to Pr.139**. (The commercial power supply operation is not available with vector control dedicated motors nor with PM motors.)

◆ Handling of the manual contactor on the inverter's output side

A PM motor is a synchronous motor with high-performance magnets embedded inside. High-voltage is generated at the motor terminals while the motor is running even after the inverter power is turned OFF. In an application where the PM motor is driven by the load even after the inverter is powered OFF, a low-voltage manual contactor must be connected at the inverter's output side.

NOTE

- Before wiring or inspection for a PM motor, confirm that the PM motor is stopped. In an application, such as fan and blower, where the motor is driven by the load, a low-voltage manual contactor must be connected at the inverter's output side, and wiring and inspection must be performed while the contactor is open. Otherwise you may get an electric shock.
- Do not open or close the contactor while the inverter is running (outputting).

3.5 Countermeasures against deterioration of the 400 V class motor insulation

In the PWM type inverter, a surge voltage attributable to wiring constants is generated at the motor terminals. Especially in a 400 V class motor, the surge voltage may deteriorate the insulation. When the 400 V class motor is driven by the inverter, consider the following countermeasures:

• Countermeasures
(With induction motor)

It is recommended to take one of the following countermeasures:

- Rectifying the motor insulation and limiting the PWM carrier frequency according to the wiring length
For the 400 V class motor, use an insulation-enhanced motor.
Specifically,
 - Order a "400 V class inverter-driven insulation-enhanced motor".
 - For the dedicated motor such as the constant-torque motor and low-vibration motor, use an "inverter-driven dedicated motor".
 - Set **Pr.72 PWM frequency selection** as indicated below according to the wiring length.

	Wiring length	
	100 m or shorter	Longer than 100 m
Pr.72 PWM frequency selection	6 (6 kHz) or lower	4 (4 kHz) or lower

- Suppressing the surge voltage on the inverter side
 - If the motor capacity is 280 kW or lower, connect the sine wave filter (MT-BSL/BSC) to the output side.

(With PM motor)

- When the wiring length exceeds 50 m, set "9" (6 kHz) or less in **Pr.72 PWM frequency selection**.

NOTE

- When using the optional sine wave filter (MT-BSL/BSC), set **Pr.72**="25" (2.5 kHz).
- For the details of the sine wave filter (MT-BSL/BSC), refer to the Instruction Manual of each option.
- A sine wave filter (MT-BSL/BSC) can be used under V/F control. Do not use the filters under different control methods.
- The carrier frequency is limited during PM sensorless vector control. (Refer to the FR-A800 Instruction Manual (Detailed))

3.6 Checklist before starting operation

The FR-A800 series inverter and FR-CC2 converter unit are highly reliable products, but incorrect peripheral circuit making or operation/handling method may shorten the product life or damage the products.

Before starting operation, always recheck the following points.

Checkpoint	Countermeasure	Refer to page	Check by user
Crimping terminals are insulated.	Use crimping terminals with insulation sleeves to wire the power supply and the motor.	-	
The wiring between the power supply (R/L1, S/L2, T/L3) and the motor (U, V, W) is correct.	Application of power to the output terminals (U, V, W) of the inverter will damage the inverter. Never perform such wiring.	31	
No wire offcuts are left from the time of wiring.	Wire offcuts can cause an alarm, failure or malfunction. Always keep the inverter and the converter unit clean. When drilling mounting holes in an enclosure etc., take caution not to allow chips and other foreign matter to enter the inverter and the converter unit.	-	
The main circuit cable gauge is correctly selected.	Use an appropriate cable gauge to suppress the voltage drop to 2% or less. If the wiring distance is long between the inverter and motor, a voltage drop in the main circuit will cause the motor torque to decrease especially during the output of a low frequency.	32	
The total wiring length within the specified length.	Keep the total wiring length is within the specified length. In long distance wiring, charging currents due to stray capacitance in the wiring may degrade the fast-response current limit operation or cause the equipment on the inverter's output side to malfunction. Pay attention to the total wiring length.	32	
Countermeasures are taken against EMI.	The input/output (main circuit) of the inverter and the converter unit includes high frequency components, which may interfere with the communication devices (such as AM radios) used near the inverter and the converter unit. In such case, activate the EMC filter (turn ON the EMC filter ON/OFF connector) to minimize interference.	74	
On the inverter's output side, none of the power factor correction capacitor, surge suppressor, or radio noise filter is installed.	Doing so will cause the inverter to trip or the capacitor and surge suppressor to be damaged. If any of the above devices is connected, immediately remove it.	-	
When performing an inspection or rewiring on the product that has been energized, the operator has waited long enough after shutting off the power supply.	For a short time after the power-OFF, a high voltage remains in the smoothing capacitor, and it is dangerous. Before performing an inspection or rewiring, wait 10 minutes or longer after the power supply turns OFF, then confirm that the voltage across the main circuit terminals P/+ and N/- of the inverter is low enough using a tester, etc.	-	
The inverter's output side has no short circuit or ground fault occurring.	<ul style="list-style-type: none"> • A short circuit or earth (ground) fault on the inverter's output side may damage the inverter module. • Fully check the insulation resistance of the circuit prior to inverter operation since repeated short circuits caused by peripheral circuit inadequacy or an earth (ground) fault caused by wiring inadequacy or reduced motor insulation resistance may damage the inverter module. • Fully check the to-earth (ground) insulation and phase-to-phase insulation of the inverter's output side before power-ON. Especially for an old motor or use in hostile atmosphere, securely check the motor insulation resistance, etc. 	-	
The circuit is not configured to use the converter unit's input-side magnetic contactor to start/stop the inverter frequently.	Since repeated inrush currents at power ON will shorten the life of the inverter and the converter unit, frequent starts and stops of the magnetic contactor must be avoided. Turn ON/OFF the inverter's start signals (STF, STR) to run/stop the inverter.	79	
The voltage applied to the I/O signal circuits of the inverter and the converter unit is within the specifications.	Application of a voltage higher than the permissible voltage to the I/O signal circuits of the inverter and the converter unit or opposite polarity may damage the I/O devices. Especially check the wiring to prevent the speed setting potentiometer from being connected incorrectly to short circuit the terminals 10E and 5.	36	

Checklist before starting operation

Checkpoint	Countermeasure	Refer to page	Check by user
The converter unit and the inverter are correctly connected.	<ul style="list-style-type: none"> Make sure that the terminal P/+ of the converter unit and the terminal P/+ of the inverter, and the terminal N/- of the converter unit and the terminal N/- of the inverter are correctly connected. Connecting the opposite polarity of terminals N/- and P/+ will damage the inverter. Also, do not install an MCCB across the terminals P/+ and N/- (across terminals P and P/+ or across N and N/-). Always connect the terminal RDA of the converter unit and the terminal MRS (X10) of the inverter, and the terminal SE of the converter unit and the terminal SD (terminal PC for source logic) of the inverter. Not connecting these terminals may damage the converter unit. 	29	
When using the electronic bypass operation, electrical and mechanical interlocks are provided between the electronic bypass contactors MC1 and MC2.	<p>When using a switching circuit as shown below, chattering due to mis-configured sequence or arc generated at switching may allow undesirable current to flow in and damage the inverter. Mis-wiring may also damage the inverter. (The commercial power supply operation is not available with vector control dedicated motors nor with PM motors.)</p> <p>When switching to the commercial power supply operation while a failure such as an output short circuit is occurring between the magnetic contactor MC2 and the motor, the damage may further spread. When a failure occurs between the MC2 and motor, make sure to provide a protection circuit, such as using the OH signal input.</p>	-	
A countermeasure is provided for power restoration after a power failure.	If the machine must not be restarted when power is restored after a power failure, provide an MC in the converter unit's input side and also make up a sequence which will not switch ON the start signal. If the start signal (start switch) remains ON after a power failure, the inverter will automatically restart as soon as the power is restored.	-	
When using the vector control, the encoder is properly installed.	The encoder must be directly connected to a motor shaft without any backlash. (Real sensorless vector control, PM sensorless vector control do not require an encoder.)	56	
A magnetic contactor (MC) is installed on the converter unit's input side.	<p>On the converter unit's input side, connect an MC for the following purposes:</p> <ul style="list-style-type: none"> To disconnect the inverter and the converter unit from the power supply at activation of a protective function or at malfunctioning of the driving system (emergency stop, etc.). To prevent any accident due to an automatic restart at power restoration after an inverter stop made by a power failure. To separate the inverter and the converter unit from the power supply to ensure safe maintenance and inspection work. <p>If using an MC for emergency stop during operation, select an MC regarding the converter unit input side current as JEM 1038-AC-3 class rated current.</p>	79	
The magnetic contactor on the inverter's output side is properly handled.	Switch the magnetic contactor between the inverter and motor only when both the inverter and motor are at a stop.	79	
When using a PM motor, a low-voltage manual contactor is installed on the inverter's output side.	A PM motor is a synchronous motor with high-performance magnets embedded inside. High-voltage is generated at the motor terminals while the motor is running even after the inverter power is turned OFF. In an application, such as fan and blower, where the motor is driven by the load, a low-voltage manual contactor must be connected at the inverter's output side, and wiring and inspection must be performed while the contactor is open. Otherwise you may get an electric shock.	79	
An EMI countermeasure is provided for the frequency setting signals.	<p>If electromagnetic noise generated from the inverter and the converter unit causes frequency setting signal to fluctuate and the motor rotation speed to be unstable when changing the motor speed with analog signals, the following countermeasures are effective:</p> <ul style="list-style-type: none"> Do not run the signal cables and power cables (inverter and converter unit I/O cables) in parallel with each other and do not bundle them. Run signal cables as far away as possible from power cables (inverter and converter I/O cables). Use shielded cables. Install a ferrite core on the signal cable (Example: ZCAT3035-1330 TDK). 	-	

Checkpoint	Countermeasure	Refer to page	Check by user
A countermeasure is provided for an overload operation.	When performing frequent starts/stops by the inverter, rise/fall in the temperature of the transistor element of the inverter will repeat due to a repeated flow of large current, shortening the life from thermal fatigue. Since thermal fatigue is related to the amount of current, the life can be increased by reducing current at locked condition, starting current, etc. Reducing current may extend the service life but may also cause torque shortage, which leads to a start failure. Adding a margin to the current can eliminate such a condition. For an induction motor, use the inverter and the converter unit of a higher capacity (up to two ranks). For a PM motor, use the inverter and the converter unit, and PM motor of higher capacities.	-	
The specifications and rating match the system requirements.	Make sure that the specifications and rating match the system requirements.	-	
Countermeasures are taken against electrical corrosion on the motor bearing.	<p>When a motor is driven by the inverter, axial voltage is generated on the motor bearing, which may cause electrical corrosion of the bearing in rare cases depending on: condition of the grease used for the bearing, wiring, load, operating conditions of the motor, or specific inverter settings (high carrier frequency, EMC filter ON). Contact your sales representative to take appropriate countermeasures for the motor.</p> <p>The following shows examples of countermeasures for the inverter.</p> <ul style="list-style-type: none"> • Decrease the carrier frequency. • Turn OFF the EMC filter. • Provide a common mode choke *1 on the output side of the inverter. (This is effective regardless of the EMC filter ON/OFF connector setting.) <p>*1 Recommended common mode choke: FT-3KM F series FINEMET® common mode choke cores manufactured by Hitachi Metals, Ltd. FINEMET is a registered trademark of Hitachi Metals, Ltd.</p>	-	

3.7 Failsafe system which uses the inverter

When a fault is detected by the protective function, the protective function activates and outputs a fault signal. However, a fault signal may not be output at an inverter's fault occurrence when the detection circuit or output circuit fails, etc. Although Mitsubishi assures the best quality products, provide an interlock which uses inverter status output signals to prevent accidents such as damage to the machine when the inverter fails for some reason. Also at the same time consider the system configuration where a failsafe from outside the inverter, without using the inverter, is enabled even if the inverter fails.

◆ Interlock method which uses the inverter status output signals

By combining the inverter output signals to provide an interlock as shown below, an inverter failure can be detected.

No.	Interlock method	Check method	Used signals
a	Inverter protective function operation	Operation check of an alarm contact. Circuit error detection by negative logic.	Fault output signal (ALM signal)
b	Inverter operating status	Operation ready signal check.	Operation ready signal (RY signal)
c	Inverter running status	Logic check of the start signal and running signal.	Start signal (STF signal, STR signal) Inverter running signal (RUN signal)
d	Inverter running status	Logic check of the start signal and output current.	Start signal (STF signal, STR signal) Output current detection signal (Y12 signal)

(a) Checking by the output of the inverter fault signal

When the inverter's protective function activates and the inverter trips, the fault output signal (ALM signal) is output. (ALM signal is assigned to terminal A1B1C1 in the initial setting).

With this signal, check that the inverter operates properly.

In addition, negative logic can be set. (ON when the inverter is normal, OFF when the fault occurs.)

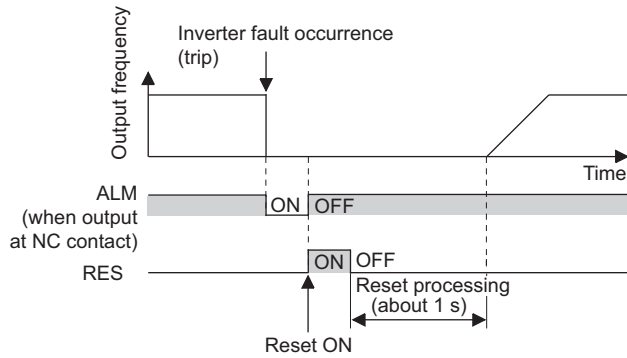

(b) Checking the inverter operating status by the inverter operation ready completion signal

Operation ready signal (RY signal) is output when the inverter power is ON and the inverter becomes operative.

Check if the RY signal is output after powering ON the inverter.

(c) Checking the inverter operating status by the start signal input to the inverter and inverter running signal

The inverter running signal (RUN signal) is output when the inverter is running. (RUN signal is assigned to terminal RUN in the initial setting.)

Check if Y12 signal is being output while inputting a start signal to the inverter. (STF signal is a forward rotation signal, and STR is a reverse rotation signal.) Even after the start signal is turned OFF, the RUN signal is kept output until the inverter makes the motor to decelerate and to stop. For the logic check, configure a sequence considering the inverter's deceleration time.

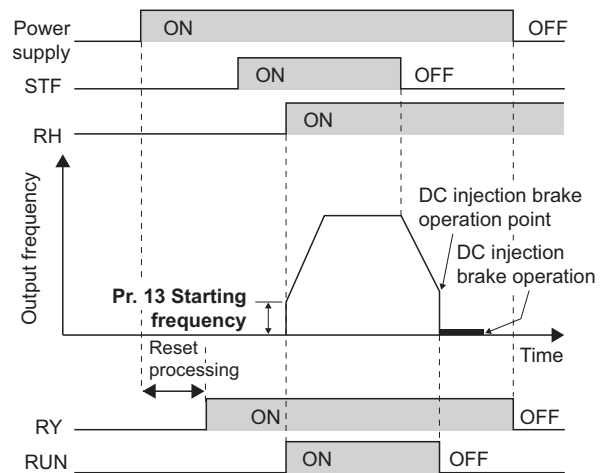

(d) Checking the motor operating status by the start signal input to the inverter and inverter output current detection signal
 The output current detection signal (Y12 signal) is output when the inverter operates and current flows into the motor. Check if Y12 signal is being output while inputting a start signal to the inverter. (STF signal is a forward rotation signal, and STR is a reverse rotation signal.) The Y12 signal is initially set to be output at 150% rated inverter current. Adjust the level to around 20% using no load current of the motor as reference with **Pr.150 Output current detection level**. Like the inverter running signal (RUN signal), even after the start signal is turned OFF, the Y12 signal is kept output until the inverter stops the output to a decelerating motor. For the logic check, configure a sequence considering the inverter's deceleration time.

Output signal	Pr.190 to Pr.196 setting	
	Positive logic	Negative logic
ALM	99	199
RY	11	111
RUN	0	100
Y12	12	112

- When using various signals, assign the functions to **Pr.190 and Pr.196 (output terminal function selection)** referring to the table on the left.

NOTE

- Changing the terminal assignment using **Pr.190 and Pr.196 (output terminal function selection)** may affect the other functions. Set parameters after confirming the function of each terminal.
- For the details of the parameters and signals, refer to the FR-A800 Instruction Manual (Detailed).

◆Backup method outside the inverter

Even if the interlock is provided by the inverter status signal, enough failsafe is not ensured depending on the failure status of the inverter itself. For example, if an inverter CPU fails in a system interlocked with the inverter's fault, start, and RUN signals, no fault signal will be output and the RUN signal will be kept ON because the inverter CPU is down.

Provide a speed detector to detect the motor speed and current detector to detect the motor current and consider the backup system such as performing a check as below according to the level of importance of the system.

(a) Start signal and actual operation check

Check the motor running and motor current while the start signal is input to the inverter by comparing the start signal to the inverter and detected speed of the speed detector or detected current of the current detector. Note that the current is flowing through the motor while the motor coasts to stop, even after the inverter's start signal is turned OFF. For the logic check, configure a sequence considering the inverter's deceleration time. In addition, it is recommended to check the three-phase current when using the current detector.

(b) Command speed and actual operation check

Check for a gap between the actual speed and commanded speed by comparing the inverter's speed command and the speed detected by the speed detector.

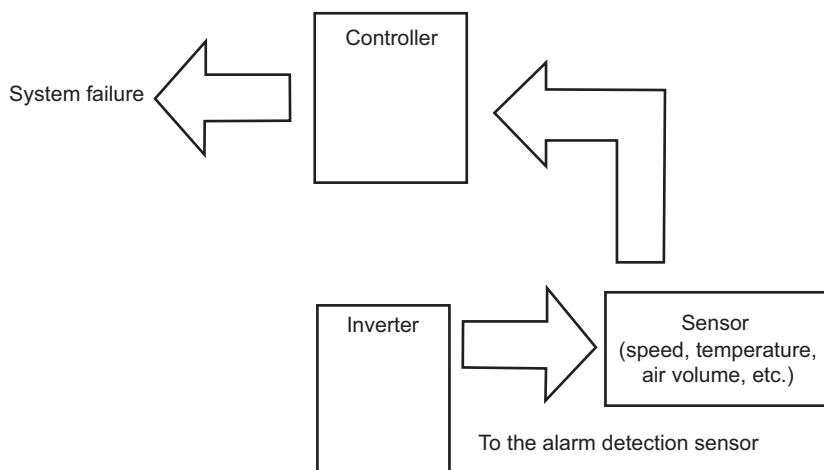

MEMO

4 PROTECTIVE FUNCTIONS

This chapter explains the "PROTECTIVE FUNCTIONS" that operate in this product.

Always read the instructions before using the equipment.

4.1	Inverter fault and alarm indications	88
4.2	Reset method for the protective functions.....	88
4.3	Check and clear of the fault history	89
4.4	List of fault displays	91

4.1 Inverter fault and alarm indications

- When the inverter detects a fault, depending on the nature of the fault, the operation panel displays an error message or warning, or a protective function activates to trip the inverter.
- When any fault occurs, take an appropriate corrective action, then reset the inverter, and resume the operation. Restarting the operation without a reset may break or damage the inverter.
- When a protective function activates, note the following points.

Item	Description
Fault output signal	Opening the magnetic contactor (MC) provided on the input side of the inverter at a fault occurrence shuts off the control power to the inverter, therefore, the fault output will not be retained.
Fault or alarm indication	When a protective function activates, the operation panel displays a fault indication.
Operation restart method	While a protective function is activated, the inverter output is kept shutoff. Reset the inverter to restart the operation.

- Inverter fault or alarm indications are categorized as below.

Displayed item	Description
Error message	A message regarding an operational fault and setting fault by the operation panel (FR-DU08) and parameter unit (FR-PU07) is displayed. The inverter does not trip.
Warning	The inverter does not trip even when a warning is displayed. However, failure to take appropriate measures will lead to a fault.
Alarm	The inverter does not trip. An Alarm (LF) signal can also be output with a parameter setting.
Fault	A protective function activates to trip the inverter and output a Fault (ALM) signal.

NOTE

- For the details of fault displays and other malfunctions, refer to the FR-A800 Instruction Manual (Detailed).
- The past eight faults can be displayed on the operation panel. (Fault history) (For operation, refer to [page 89](#).)

4.2 Reset method for the protective functions

Reset the inverter by performing any of the following operations. Note that the accumulated heat value of the electronic thermal relay function and the number of retries are cleared (erased) by resetting the inverter.

The inverter recovers about 1 s after the reset is released.

- On the operation panel, press  to reset the inverter. (This may only be performed when a fault occurs.)

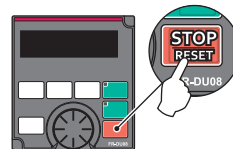

- Switch power OFF once, then switch it ON again.

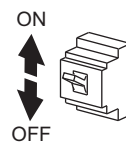

- Turn ON the reset signal (RES) for 0.1 s or more. (If the RES signal is kept ON, "Err" appears (flickers) to indicate that the inverter is in a reset status.)

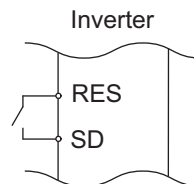

NOTE

- OFF status of the start signal must be confirmed before resetting the inverter fault. Resetting an inverter fault with the start signal ON restarts the motor suddenly.

4.3 Check and clear of the fault history

The operation panel stores the fault indications which appears when a protective function is activated to display the fault record for the past eight faults. (Fault history)

◆ Check for the fault history

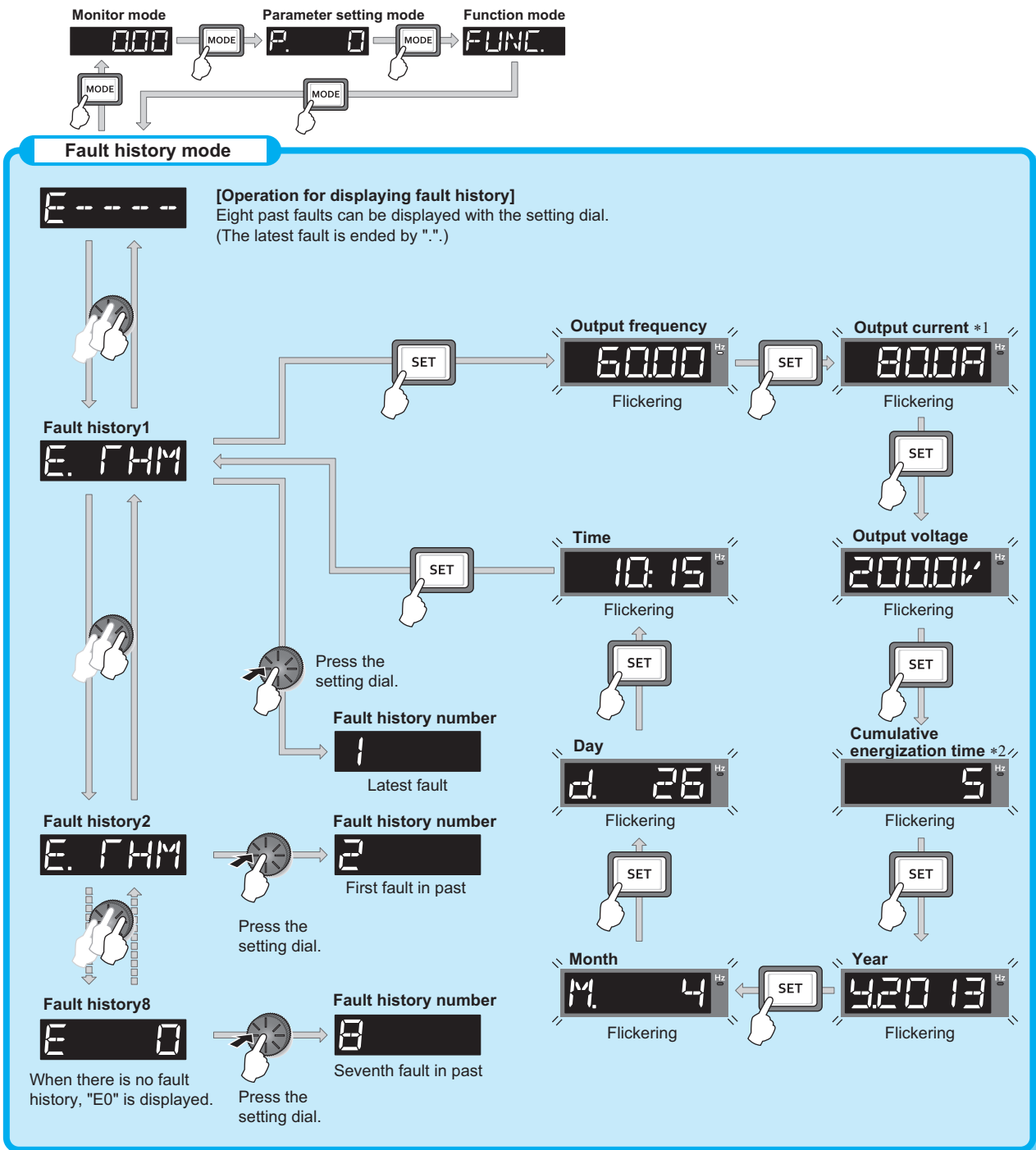

*1 When an overcurrent trip occurs by an instantaneous overcurrent, the monitored current value saved in the fault history may be lower than the actual current that has flowed.

*2 The cumulative energization time and actual operation time are accumulated from 0 to 65535 hours, then cleared, and accumulated again from 0.









◆ Fault history clearing procedure



POINT

- Set Err.CL Fault history clear = "1" to clear the fault history.

Operation

1.	Screen at power-ON The monitor display appears.
2.	Parameter setting mode Press  to choose the parameter setting mode. (The parameter number read previously appears.)
3.	Selecting the parameter number Turn  until Err.CL (fault history clear) appears. Press  to read the present set value. "0" (initial value) appears.
4.	Fault history clear Turn  to change the set value to "1". Press  to start clear. "1" and "Err.CL" flicker alternately after parameters are cleared. • Turn  to read another parameter. • Press  to show the setting again. • Press  twice to show the next parameter.

4.4 List of fault displays

For details, refer to the FR-A800 Instruction Manual (Detailed).

Operation panel indication		Name	
Error message	HOLd	HOLD	Operation panel lock
	LOCd	LOCD	Password locked
	Er 1 to Er 4 Er 8	Er1 to Er4 Er8	Parameter write error
	rE 1 to rE 8	rE1 to rE8	Copy operation error
	Err.	Err.	Error
Warning	OL	OL	Stall prevention (overcurrent)
	oL	oL	Stall prevention (overvoltage)
	TH	TH	Electronic thermal relay function pre-alarm
	PS	PS	PU stop
	SL	SL	Speed limit indication (output during speed limit)
	CF	CF	Continuous operation during communication fault
	CP	CP	Parameter copy
	SA	SA	Safety stop
	MT 1 to MT 3	MT1 to MT3	Maintenance timer 1 to 3
	UF	UF	USB host error
	HP 1	HP1	Home position return setting error
	HP 2	HP2	Home position return uncompleted
	HP 3	HP3	Home position return parameter setting error
	LdF	LDF	Load fault warning
Alarm	FN	FN	Fan alarm
Fault	E. OC 1	E.OC1	Overcurrent trip during acceleration
	E. OC 2	E.OC2	Overcurrent trip during constant speed
	E. OC 3	E.OC3	Overcurrent trip during deceleration or stop
	E. OV 1	E.OV1	Regenerative overvoltage trip during acceleration
	E. OV 2	E.OV2	Regenerative overvoltage trip during constant speed
	E. OV 3	E.OV3	Regenerative overvoltage trip during deceleration or stop
	E. THF	E.THT	Inverter overload trip (electronic thermal relay function)
	E. THM	E.THM	Motor overload trip (electronic thermal relay function)
	E. FIN	E.FIN	Heat sink overheat
	E. OLF	E.OLT	Stall prevention stop
	Fault	E. SOT	E. SOT
E. GF		E. GF	Output side earth (ground) fault overcurrent
E. LUP		E.LUP	Upper limit fault detection
E. LDN		E.LDN	Lower limit fault detection
E. LF		E.LF	Output phase loss
E. OHT		E.OHT	External thermal relay operation
E. PTC		E.PTC	PTC thermistor operation
E. OPT		E.OPT	Option fault
E. OP 1 to E. OP 3		E.OP1 to E.OP3	Communication option fault
E. 16 to E. 20		E.16 to E.20	User definition error by the PLC function
E. PE		E.PE	Parameter storage device fault (control circuit board)
E. PUE		E.PUE	PU disconnection
E. RET		E.RET	Retry count excess
E. PE 2		E.PE2	Parameter storage device fault (main circuit board)
E. CPU E. 5 to E. 7		E.CPU E. 5 to E. 7	CPU fault
E. CTE		E.CTE	Operation panel power supply short circuit/RS-485 terminals power supply short circuit
E. P24		E.P24	24 VDC power fault
E. CDO		E.CDO	Abnormal output current detection
E. SER		E.SER	Communication fault (inverter)
E. AIE		E.AIE	Analog input fault
E. USB	E.USB	USB communication fault	
E. SAF	E.SAF	Safety circuit fault	
E. PBT E. 13	E.PBT E.13	Internal circuit fault	
E. OS	E.OS	Overspeed occurrence	
E. OSD	E.OSD	Speed deviation excess detection	
E. ECT	E.ECT	Signal loss detection	
E. OD	E.OD	Excessive position fault	
E. MB 1 to E. MB 7	E.MB1 to E.MB7	Brake sequence fault	
E. EP	E.EP	Encoder phase fault	
E. MP	E.MP	Magnetic pole position unknown	
E. EF	E.EF	External fault during output operation	

List of fault displays

Operation panel indication		Name	
Fault	E. LCI	E.LCI	4 mA input fault
	E. PCH	E.PCH	Pre-charge fault
	E. PId	E.PID	PID signal fault
	E. 1 to E. 3	E. 1 to E. 3	Option fault
	E. 11	E.11	Opposite rotation deceleration fault
Others	E-----	E----	Fault history
	E. 0	E. 0	No fault history
	EV	EV	24 V external power supply operation
	Rd	RD	Backup in progress
	WR	WR	Restoration in progress

If faults other than the above appear, contact your sales representative.

5 PRECAUTIONS FOR MAINTENANCE AND INSPECTION

This chapter explains the "PRECAUTIONS FOR MAINTENANCE AND INSPECTION" for this product.

Always read the instructions before using the equipment.

5.1	Inspection item.....	94
5.2	Measurement of main circuit voltages, currents and powers	101

Inspection item

The inverter is a static unit mainly consisting of semiconductor devices. Daily inspection must be performed to prevent any fault from occurring due to the adverse effects of the operating environment, such as temperature, humidity, dust, dirt and vibration, changes in the parts with time, service life, and other factors.

●Precautions for maintenance and inspection

When accessing the inverter for inspection, wait for at least 10 minutes after the power supply has been switched OFF, and then make sure that the voltage across the main circuit terminals P/+ and N/- of the inverter is not more than 30 VDC using a tester, etc.

5.1 Inspection item

5.1.1 Daily inspection

Basically, check for the following faults during operation.

- Motor operation fault
- Improper installation environment
- Cooling system fault
- Abnormal vibration, abnormal noise
- Abnormal overheat, discoloration

5.1.2 Periodic inspection

Check the areas inaccessible during operation and requiring periodic inspection.

Consult us for periodic inspection.

- Check and clean the cooling system. Clean the air filter, etc.
- Check the tightening and retighten. The screws and bolts may become loose due to vibration, temperature changes, etc. Check and tighten them.
Tighten them according to the specified tightening torque. (Refer to [page 32](#).)
- Check the conductors and insulating materials for corrosion and damage.
- Measure the insulation resistance.
- Check and change the cooling fan and relay.



- When using the safety stop function, periodic inspection is required to confirm that safety function of the safety system operates correctly.
For more details, refer to the Safety Stop Function Instruction Manual.

5.1.3 Daily and periodic inspection

Area of inspection	Inspection item	Description	Inspection interval		Corrective action at fault occurrence	Check by the user	
			Daily	Periodic *3			
General	Surrounding environment	Check the surrounding air temperature, humidity, dirt, corrosive gas, oil mist, etc.	○		Improve the environment.		
	Overall unit	Check for unusual vibration and noise.	○		Check fault location and retighten.		
		Check for dirt, oil, and other foreign material.*1	○		Clean.		
	Power supply voltage	Check that the main circuit voltages and control voltages are normal.*2	○		Inspect the power supply.		
Main circuit	General	(1) Check with megger (across main circuit terminals and earth (ground) terminal).		○	Contact the manufacturer.		
		(2) Check for loose screws and bolts.		○	Retighten.		
		(3) Check for overheat traces on the parts.		○	Contact the manufacturer.		
		(4) Check for stain.		○	Clean.		
	Conductors, cables	(1) Check conductors for distortion.		○	Contact the manufacturer.		
		(2) Check cable sheaths for breakage and deterioration (crack, discoloration, etc.).		○	Contact the manufacturer.		
Transformer/reactor	Check for unusual odor and abnormal increase of whining sound.	○		Stop the equipment and contact the manufacturer.			
Terminal block	Check for a damage.		○	Stop the equipment and contact the manufacturer.			
Smoothing aluminum electrolytic capacitor	(1) Check for liquid leakage.		○	Contact the manufacturer.			
	(2) Check for safety valve projection and bulge.		○	Contact the manufacturer.			
Relay/contactors	Check that the operation is normal and no chattering sound is heard.		○	Contact the manufacturer.			
Control circuit, protective circuit	Operation check	(1) Check that the output voltages across phases are balanced while operating the inverter alone.		○	Contact the manufacturer.		
		(2) Check that no fault is found in protective and display circuits in a sequence protective operation test.		○	Contact the manufacturer.		
	Components check	Overall	(1) Check for unusual odor and discoloration.		○	Stop the equipment and contact the manufacturer.	
		(2) Check for serious rust development.		○	Contact the manufacturer.		
Aluminum electrolytic capacitor	(1) Check for liquid leakage in a capacitor and deformation trace.		○	Contact the manufacturer.			
	(2) Visual check and judge by the life check of the control circuit capacitor. (Refer to the FR-A800 Instruction Manual (Detailed)).		○				
Cooling system	Cooling fan	(1) Check for unusual vibration and noise.	○		Replace the fan.		
		(2) Check for loose screws and bolts.		○	Fix with the fan cover fixing screws		
(3) Check for stain.			○	Clean.			
Heat sink	(1) Check for clogging.		○	Clean.			
	(2) Check for stain.		○	Clean.			
Display	Indication	(1) Check that display is normal.	○		Contact the manufacturer.		
	(2) Check for stain.		○	Clean.			
	Meter	Check that reading is normal.	○		Stop the equipment and contact the manufacturer.		
Load motor	Operation check	Check for vibration and abnormal increase in operation noise.	○		Stop the equipment and contact the manufacturer.		

*1 Oil component of the heat dissipation grease used inside the inverter may leak out. The oil component, however, is not flammable, corrosive, nor conductive and is not harmful to humans. Wipe off such oil component.

*2 It is recommended to install a voltage monitoring device for checking the voltage of the power supplied to the inverter.

*3 One to two years of periodic inspection cycle is recommended. However, it differs according to the installation environment. Consult us for periodic inspection.

NOTE

- Continuous use of a leaked, deformed, or degraded smoothing aluminum electrolytic capacitor (as shown in the table above) may lead to a burst, breakage or fire. Replace such capacitor without delay.

5.1.4 Checking the inverter and converter semiconductor devices

◆Preparation

- Disconnect the external power supply cables (R/L1, S/L2, T/L3) and motor cables (U, V, W). (The inverter and the converter unit (FR-CC2) can be measured with those cables connected.)
- Prepare a tester. (For the resistance measurement, use the 100 Ω range.)

◆Checking method

Change the polarity of the tester alternately at the inverter terminals R/L1, S/L2, T/L3, U, V, W, P/+, and N/- and check the electric continuity.

NOTE

- Before measurement, check that the smoothing capacitor is discharged.
- At the time of electric discontinuity, the measured value is almost ∞. When there is an instantaneous electric continuity, due to the smoothing capacitor, the tester may not indicate ∞. At the time of electric continuity, the measured value is several Ω to several tens of Ω. If all measured values are almost the same, although these values are not constant depending on the module type and tester type, the modules are without fault.

◆Semiconductor device numbers and terminals to be checked

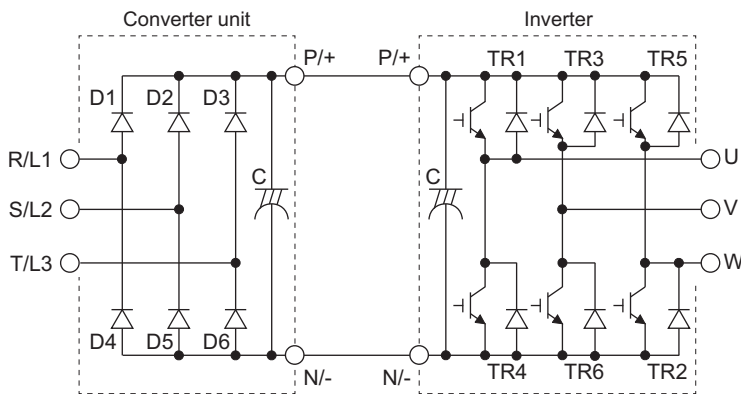

		Tester polarity		Result			Tester polarity		Result
		⊕	⊖				⊕	⊖	
Converter unit	D1	R/L1, P/+		Discontinuity	D4	R/L1, N/-		Continuity	
		P/+ R/L1		Continuity		N/- R/L1		Discontinuity	
	D2	S/L2, P/+		Discontinuity	D5	S/L2, N/-		Continuity	
		P/+ S/L2		Continuity		N/- S/L2		Discontinuity	
	D3	T/L3, P/+		Discontinuity	D6	T/L3, N/-		Continuity	
		P/+ T/L3		Continuity		N/- T/L3		Discontinuity	
Inverter	TR1	U P/+		Discontinuity	TR4	U N/-		Continuity	
		P/+ U		Continuity		N/- U		Discontinuity	
	TR3	V P/+		Discontinuity	TR6	V N/-		Continuity	
		P/+ V		Continuity		N/- V		Discontinuity	
	TR5	W P/+		Discontinuity	TR2	W N/-		Continuity	
		P/+ W		Continuity		N/- W		Discontinuity	

(Assumes the use of an analog meter.)

5.1.5 Cleaning

Always run the inverter in a clean status.

When cleaning the inverter, gently wipe dirty areas with a soft cloth immersed in neutral detergent or ethanol.

NOTE

- Do not use solvent, such as acetone, benzene, toluene and alcohol, as these will cause the inverter surface paint to peel off.
- The display, etc. of the operation panel and parameter unit are vulnerable to detergent and alcohol. Therefore, avoid using them for cleaning.

5.1.6 Replacement of parts

The inverter consists of many electronic parts such as semiconductor devices.

The following parts may deteriorate with age because of their structures or physical characteristics, leading to reduced performance or fault of the inverter. For preventive maintenance, the parts must be replaced periodically.

Use the life check function as a guidance of parts replacement.

Part name	Estimated lifespan*1	Description
Cooling fan	10 years	Replace (as required)
Main circuit smoothing capacitor	10 years*2	Replace (as required)
On-board smoothing capacitor	10 years*2	Replace the board (as required)
Relays	—	As required
Main circuit fuse	10 years	Replace (as required)

*1 Estimated lifespan for when the yearly average surrounding air temperature is 40°C.
(without corrosive gas, flammable gas, oil mist, dust and dirt etc.)

*2 Output current (80% of the inverter rating)

NOTE

- For parts replacement, contact the nearest Mitsubishi FA center.

◆ Inverter parts life display

The inverter diagnoses the control circuit capacitor and the cooling fan by itself, and estimates their lives.

The self-diagnostic warning is output when the life span of each part is near its end. It gives an indication of replacement time.

The life warning output can be used as a guideline for life judgment.

Parts	Judgment level
Control circuit capacitor	Estimated remaining life 10%
Cooling fan	Not more than the specified speed

NOTE

- Refer to the FR-A800 Instruction Manual (Detailed) to perform the life check of the inverter parts.

◆ Replacement procedure of the cooling fan

The replacement interval of the cooling fan used for cooling the parts generating heat such as the main circuit semiconductor is greatly affected by the surrounding air temperature. When unusual noise and/or vibration are noticed during inspection, the cooling fan must be replaced immediately.

◆ Removal

- 1) Remove the fan cover fixing screws, and remove the fan cover.
- 2) Disconnect the fan connector and remove the fan block.
- 3) Remove the fan fixing screws, and remove the fan.

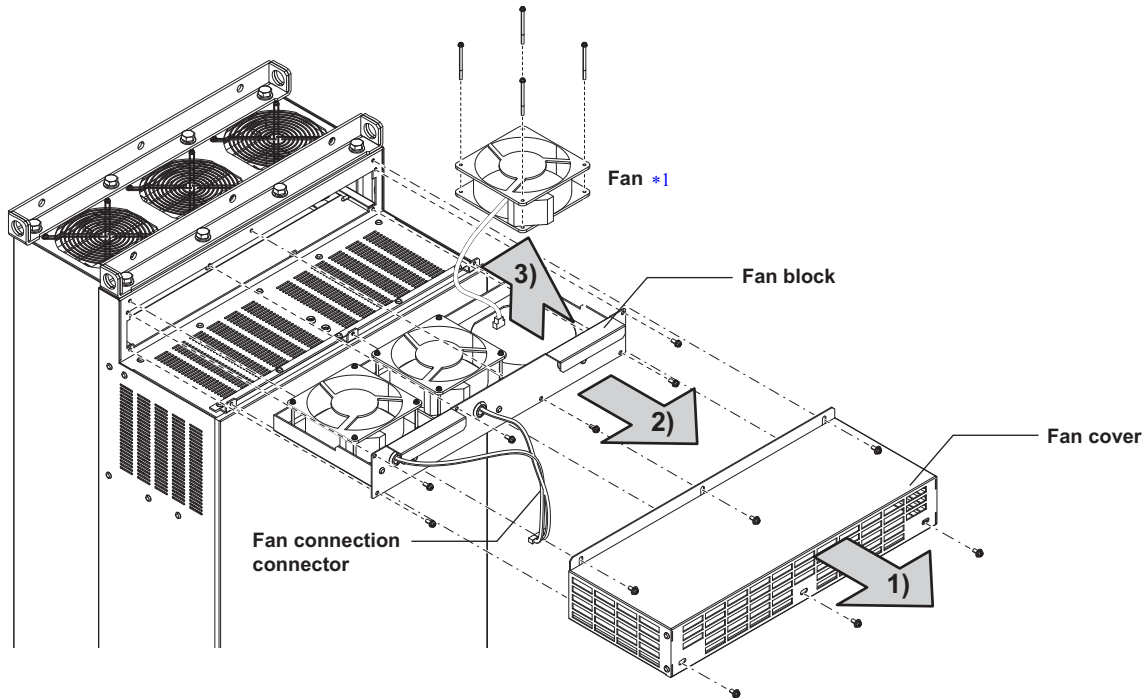

*1 The number of cooling fans differs according to the inverter capacity.

◆ Reinstallation

- 1) After confirming the orientation of the fan, reinstall the fan so that the "AIR FLOW" faces up.

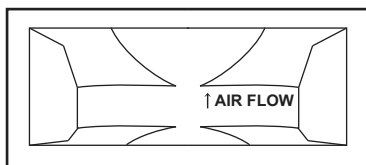

<Fan side face>

- 2) For reconnection of the fan, refer to the above figure. Tightening torque of the fan fixing screws is 0.73 N·m.

NOTE

- Installing the fan in the opposite direction of air flow can cause the inverter life to be shorter.
- Prevent the cable from being caught when installing a fan.
- Switch the power OFF before replacing fans. Since the inverter circuits are charged with voltage even after power OFF, replace fans only when the inverter cover is on the inverter to prevent an electric shock accident.

◆Smoothing capacitors

A large-capacity aluminum electrolytic capacitor is used for smoothing in the DC section of the main circuit, and an aluminum electrolytic capacitor is used for stabilizing the control power in the control circuit. Adverse effects from ripple currents deteriorate capacitors. Replacement intervals of capacitors vary greatly with surrounding temperatures and operating conditions. Replace them roughly every 10 years when used in normal air-conditioned environments.

Inspecting the product visually:

- Case: Check that the sides and bottom of the capacitor have not ruptured.
- Rubber seal: Check for any noticeable bulging or severe cracks.
- Check for external cracks, discoloration, leakage, etc. It is assumed that the capacitor has reached the end of its life when its capacity has dropped below 80% of its rated capacity.

NOTE

- The inverter diagnoses the control circuit capacitor by itself and can estimate its remaining life. Refer to the FR-A800 Instruction Manual (Detailed).

◆Relay output terminals

- The contacts of relays deteriorate over time. To prevent faults from occurring, relays must be replaced when they have reached the maximum number of switching operations (switching life).
- The control terminal block must be replaced in case of failure of either relay between the relay output terminals C1 and B1 or A1, or terminals C2 and B2 or A2.

◆Main circuit fuse

A fuse is used inside the inverter. Replacement intervals of fuses vary with surrounding temperatures and operating conditions. Replace them roughly every 10 years when used in normal air-conditioned environments.

5.1.7 Removal and reinstallation of the control circuit terminal block

This product has a removable control circuit terminal block, which can be replaced with a new one or a control terminal option.

◆Removal and reinstallation

- 1) Loosen the two installation screws at the both side of the control circuit terminal block. (These screws cannot be removed.) Slide down the control circuit terminal block to remove it.

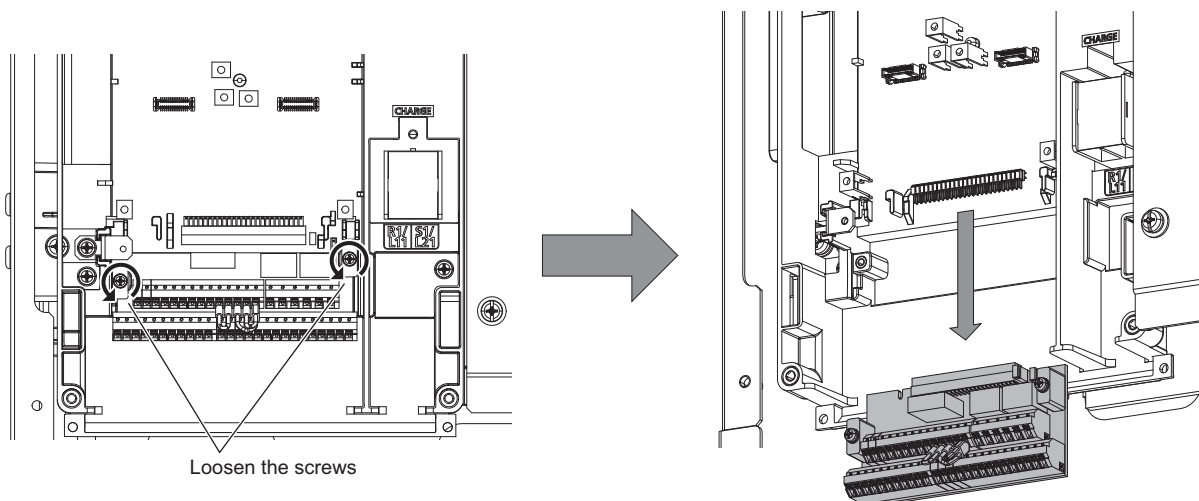

- 2) Be careful not to bend the pins of the inverter's control circuit connector, reinstall the control circuit terminal block and fix it with the mounting screws.

NOTE

- Before starting inverter replacement, switch OFF the power, wait for at least 10 minutes, and then check the voltage with a tester and such to ensure safety.

◆ Removal and reinstallation precautions

Precautions to be taken when removing or reinstalling the control circuit terminal block are shown below. Observe the following precautions and handle the inverter properly to avoid malfunctions or failures.

- To remove or reinstall the control circuit terminal block, keep it upright so that it is parallel with the inverter.
- To install the control circuit terminal block, slide it upward so that the tongues on the inverter slot into the grooves on the terminal block.
- Check that the terminal block is parallel to the inverter and the pins on the inverter control circuit connector are not bent. After checking proper connection, fix the terminal block in place with two screws.

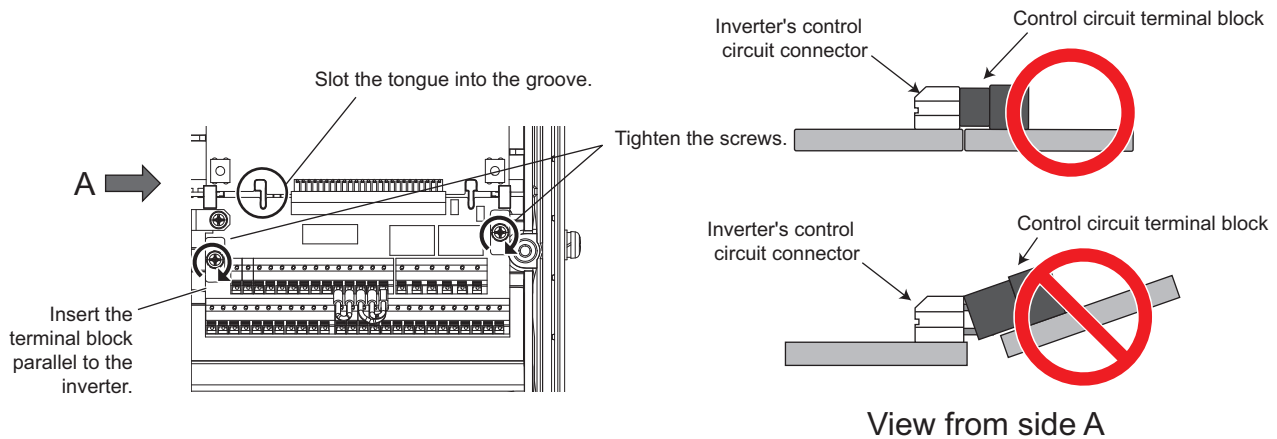

NOTE

- Do not tilt the terminal block while tightening the screws or removing it from the inverter. (Otherwise, a stress applied to the control circuit terminal block or the control circuit connector may cause damage to them.)
- After replacing the control terminal block, connect the jumper connector to the correct position in accordance with the control logic of input signals. (Refer to [page 41](#).)

5.2 Measurement of main circuit voltages, currents and powers

Since the voltages and currents on the inverter power supply and output sides include harmonics, measurement data depends on the instruments used and circuits measured.

When instruments for commercial frequency are used for measurement, measure the following circuits with the instruments given on the next page.

NOTE

- When installing meters etc. on the inverter output side

When the wiring length between the inverter and the motor is large, the meters and CTs may generate heat due to line-to-line leakage current. Therefore, choose equipment which has enough capacity for the current rating.

To measure and display the output voltage and output current of the inverter, it is recommended that the terminal AM and FM/CA output functions of the inverter are used.

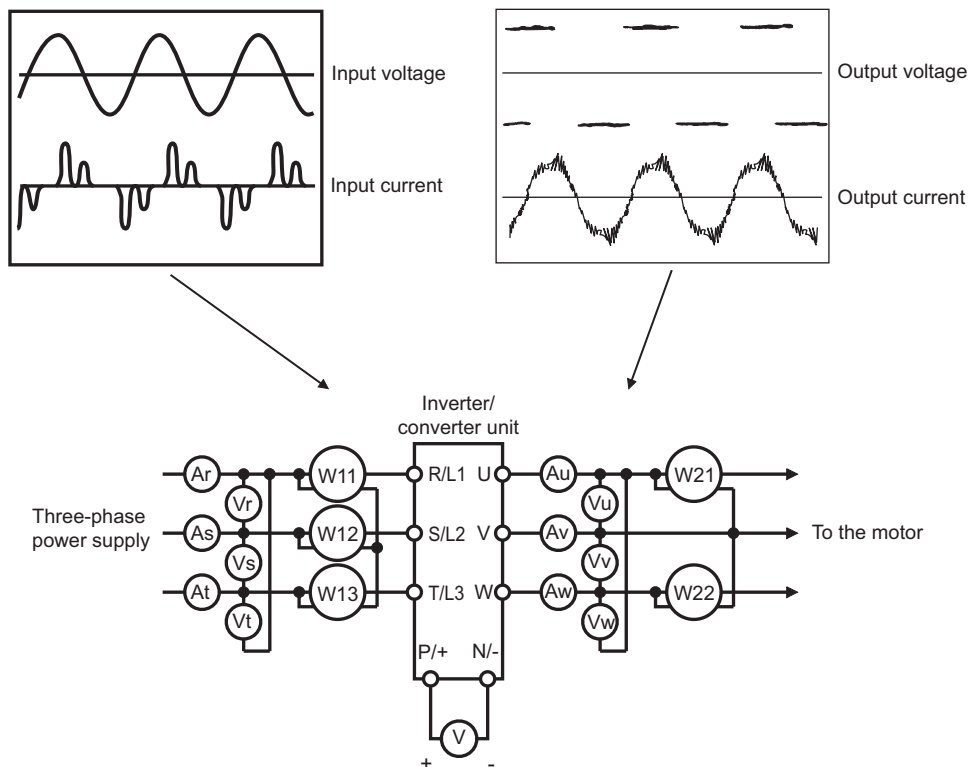

◆ Measuring points and instruments

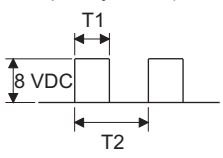
	Item	Measuring point	Measuring instrument	Remarks (reference measured value)	
Converter unit (FR-CC2)	Power supply voltage V1	Across R/L1 and S/L2, S/L2 and T/L3, T/L3 and R/L1	Digital power meter (designed for inverter)	Commercial power supply Within permissible AC voltage fluctuation (Refer to page 106.)	
	Power supply side current I1	R/L1, S/L2, T/L3 line current		P1 = W11 + W12 + W13 (3-wattmeter method)	
	Power supply side power P1	R/L1, S/L2, T/L3 and Across R/L1 and S/L2, S/L2 and T/L3, T/L3 and R/L1			
	Power supply side power factor Pf1	Calculate after measuring power supply voltage, power supply side current and power supply side power. $Pf_1 = \frac{P_1}{\sqrt{3}V_1 \times I_1} \times 100\%$			
	Converter output	Across P/+ and N/-	Digital multimeter or other tester	Inverter LED is lit. 1.35 × V1	
	Operation enable signal External thermal relay signal Reset signal	Across RDI, OH, RES(+) and SD (for sink logic)	Digital multimeter or other tester, or moving-coil type instrument (internal resistance 50 kΩ or more)	When open 20 to 30 VDC ON voltage: 1 V or less	"SD" is common
	Alarm signal	Across A1 and C1 Across B1 and C1	Digital multimeter or other tester	Continuity check*3 Across A1 and C1 Across B1 and C1	[Normal] [Fault] Discontinuity Continuity Continuity Discontinuity
Inverter	Output side voltage V2	Across U and V, V and W, and W and U	Digital power meter (designed for inverter)*1	Difference between the phases is within 1% of the maximum output voltage.	
	Output side current I2	U, V and W line currents		Difference between the phases is 10% or lower of the rated inverter current.	
	Output side power P2	U, V, W and across U and V, V and W	Digital power meter (designed for inverter)	P2 = W21 + W22 2-wattmeter method (or 3-wattmeter method)	
	Output side power factor Pf2	Calculate in similar manner to power supply side power factor. $Pf_2 = \frac{P_2}{\sqrt{3}V_2 \times I_2} \times 100\%$			
	Frequency setting signal	Across 2, 4(+) and 5 Across 1(+) and 5	Digital multimeter or other tester, or moving-coil type instrument (internal resistance 50 kΩ or more)	0 to 10 VDC, 4 to 20 mA	"5" is common
	Frequency setting power supply	Across 10(+) and 5 Across 10E(+) and 5		0 to ±5 VDC and 0 to ±10 VDC	
				5.2 VDC	
	Frequency meter signal	Across AM(+) and 5 Across CA(+) and 5 Across FM(+) and SD		10 VDC	
				Approximately 10 VDC at maximum frequency (without frequency meter)	
				Approximately 20 mADC at maximum frequency	
Start signal Select signal Reset signal Output stop signal	Across STF, STR, RH, RM, RL, JOG, RT, AU, STOP, CS, RES, MRS(+) and SD (for sink logic)	Approximately 5 VDC at maximum frequency (without frequency meter)		"SD" is common	
		 <p>Pulse width T1: Adjust with C0 (Pr.900). Pulse cycle T2: Set with Pr.55. (frequency monitor only)</p>			
Fault signal	Across A1 and C1 Across B1 and C1	Digital multimeter or other tester		Continuity check*3 Across A1 and C1 Across B1 and C1	[Normal] [Fault] Discontinuity Continuity Continuity Discontinuity

- *1 Use an FFT to measure the output voltage accurately. A tester or general measuring instrument cannot measure accurately.
- *2 When the carrier frequency exceeds 5 kHz, do not use this instrument since using it may increase eddy current losses produced in metal parts inside the instrument, leading to burnout. In this case, use an approximate-effective value type.
- *3 When the setting of Pr.195 ABC1 terminal function selection is the positive logic

5.2.1 Measurement of powers

Use a digital power meter (for inverter) for the input side of the converter unit (FR-CC2) and the output side of the inverter.

5.2.2 Measurement of voltages

◆ Converter unit (FR-CC2) input side

Use digital power meters (for inverters) for the input side voltage.

◆ Inverter output side

When using a measuring instrument, use a digital power meter for inverters as the inverter outputs PWM-controlled square wave voltage.

The value displayed on the operation panel is the inverter-controlled voltage itself. Hence, that value is accurate and it is recommended to monitor values using the operation panel.

5.2.3 Measurement of currents

Use a digital power meter (for inverter) for the input side of the converter unit (FR-CC2) and the output side of the inverter. Since the converter unit input current tends to be unbalanced, measurement of three phases is recommended. Correct value cannot be obtained by measuring only one or two phases. On the other hand, the unbalanced ratio of each phase of the output side current should be within 10%.

The inverter output current can be monitored on the operation panel. The value monitored on the operation panel is accurate if the output frequency varies, and it is recommended to monitor values (provide analog output) using the operation panel.

5.2.4 Example of measuring converter unit (FR-CC2) input power factor

Calculate using effective power and apparent power. A power-factor meter cannot indicate an exact value.

$$\begin{aligned} \text{Total power factor of the converter unit} &= \frac{\text{Effective power}}{\text{Apparent power}} \\ &= \frac{\text{Three-phase input power found by the 3-wattmeter method}}{\sqrt{3} \times V (\text{power supply voltage}) \times I (\text{input current effective value})} \end{aligned}$$

5.2.5 Measurement of converter output voltage (across terminals P and N)

The output voltage of the converter is output across terminals P and N, and can be measured with a voltmeter such as a digital multimeter. Although the voltage varies according to the power supply voltage, approximately 540 to 600 V is output when no load is connected and voltage decreases during driving load operation.

When energy is regenerated from the motor during deceleration, for example, the converter output voltage rises to nearly 800 to 900 V maximum.

5.2.6 Measurement of inverter output frequency

In the initial setting of the FM-type inverter, a pulse train proportional to the output frequency is output across the pulse train output terminals FM and SD of the inverter. This pulse train output can be counted by a frequency counter, or a digital multimeter can be used to read the mean value of the pulse train output voltage.

When a meter is used to measure the output frequency, approximately 5 VDC is indicated at the maximum frequency.

For detailed specifications of the pulse train output terminal FM, refer to the FR-A800 Instruction Manual (Detailed).

In the initial setting of the CA-type inverter, a pulse train proportional to the output frequency is output across the analog current output terminals CA and 5 of the inverter. Measure the current using a digital multimeter.

For detailed specifications of the analog current output terminal CA, refer to the FR-A800 Instruction Manual (Detailed).

5.2.7 Insulation resistance test using megger

- For the inverter and the converter unit (FR-CC2), conduct the insulation resistance test on the main circuit only as shown below and do not perform the test on the control circuit. (Use a 500 VDC megger.)

NOTE

- Before performing the insulation resistance test on the external circuit, disconnect the cables from all terminals of the inverter and the converter unit so that the test voltage is not applied to the inverter and the converter unit.
- For the continuity test of the control circuit, use a tester (high resistance range) and do not use the megger or buzzer.

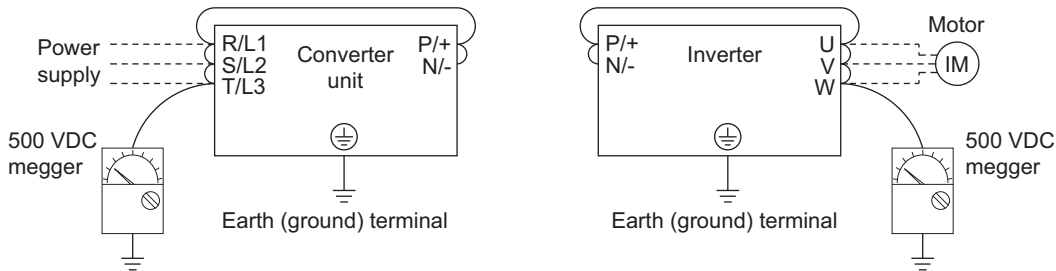

5.2.8 Pressure test

Do not conduct a pressure test. Deterioration may occur.

6 SPECIFICATIONS

This chapter explains the "SPECIFICATIONS" of this product.
Always read the instructions before using the equipment.

6.1	Inverter rating.....	106
6.2	Common specifications	107
6.3	Outline dimension drawings.....	109

6.1 Inverter rating

◆ 400 V class
• Inverter

Model FR-A842-[]-GF		07700	08660	09620	10940	12120	
		315K	355K	400K	450K	500K	
Applicable motor capacity (kW) *1	SLD	400	450	500	560	630	
	LD	355	400	450	500	560	
	ND (initial setting)	315	355	400	450	500	
	HD	280	315	355	400	450	
Output	Rated capacity (kVA) *2	SLD	587	660	733	834	924
		LD	521	587	660	733	834
		ND (initial setting)	465	521	587	660	733
		HD	417	465	521	587	660
	Rated current (A)	SLD	770	866	962	1094	1212
		LD	683	770	866	962	1094
		ND (initial setting)	610	683	770	866	962
		HD	547	610	683	770	866
Overload current rating *3	SLD	110% 60 s, 120% 3 s (inverse-time characteristics) at surrounding air temperature of 40°C					
	LD	120% 60 s, 150% 3 s (inverse-time characteristics) at surrounding air temperature of 50°C					
	ND (initial setting)	150% 60 s, 200% 3 s (inverse-time characteristics) at surrounding air temperature of 50°C					
	HD	200% 60 s, 250% 3 s (inverse-time characteristics) at surrounding air temperature of 50°C					
Rated voltage *4		Three-phase 380 to 500 V					
Regenerative braking torque*5 (When the converter unit (FR-CC2) is used)		Maximum brake torque	10% torque/continuous				
Input power	DC power supply voltage		430 to 780 VDC				
	Control power supply auxiliary input		Single phase 380 to 500 V 50 Hz/60 Hz *7				
	Permissible control power supply auxiliary input fluctuation		Frequency ±5%, voltage ±10%				
Protective structure (IEC 60529) *6		Open type (IP00)					
Cooling system		Forced air cooling					
Approx. mass (kg)		163	163	243	243	243	

- *1 The applicable motor capacity indicated is the maximum capacity applicable for use of the Mitsubishi Electric 4-pole standard motor.
- *2 The rated output capacity indicated assumes that the output voltage is 440 V.
- *3 The % value of the overload current rating indicated is the ratio of the overload current to the inverter's rated output current. For repeated duty, allow time for the inverter and motor to return to or below the temperatures under 100% load.
- *4 The maximum output voltage does not exceed the power supply voltage. The maximum output voltage can be changed within the setting range. However, the maximum point of the voltage waveform at the inverter output side is the power supply voltage multiplied by about $\sqrt{2}$.
- *5 ND rating reference value
- *6 FR-DU08: IP40 (except for the PU connector section)
- *7 For the power voltage exceeding 480 V, set **Pr.977 Input voltage mode selection**. (For details, refer to the FR-A800 Instruction Manual (Detailed).)

6.2 Common specifications

Control specifications	Control method		Soft-PWM control, high carrier frequency PWM control (selectable among V/F control, Advanced magnetic flux vector control, Real sensorless vector control), Optimum excitation control, vector control ¹ , and PM sensorless vector control
	Output frequency range		0.2 to 590 Hz (The upper-limit frequency is 400 Hz under Advanced magnetic flux vector control, Real sensorless vector control, vector control ¹ , and PM sensorless vector control.)
	Frequency setting resolution	Analog input	0.015 Hz/60 Hz (terminal 2, 4: 0 to 10 V/12 bits) 0.03 Hz/60 Hz (0 to 5 V/11 bits or 0 to 20 mA/approx. 11 bits for terminals 2 and 4, 0 to ±10 V/12 bits for terminal 1) 0.06 Hz/60 Hz (0 to ±5 V/11 bits for terminal 1)
		Digital input	0.01 Hz
	Frequency accuracy	Analog input	Within ±0.2% of the max. output frequency (25°C ±10°C)
		Digital input	Within 0.01% of the set output frequency
	Voltage/frequency characteristics		Base frequency can be set from 0 to 590 Hz. Constant-torque/variable-torque pattern or adjustable 5 points V/F can be selected.
	Starting torque		SLD rating: 120% 0.3 Hz, LD rating: 150% 0.3 Hz, ND rating: 200% ² 0.3 Hz, HD rating: 250% ² 0.3 Hz (under Real sensorless vector control or vector control ¹)
	Torque boost		Manual torque boost
	Acceleration/deceleration time setting		0 to 3600 s (acceleration and deceleration can be set individually), linear or S-pattern acceleration/deceleration mode, backlash countermeasures acceleration/deceleration can be selected.
	DC injection brake (induction motor)		Operation frequency (0 to 120 Hz), operation time (0 to 10 s), operation voltage (0 to 30%) variable
	Stall prevention operation level		Activation range of stall prevention operation (SLD rating: 0 to 120%, LD rating: 0 to 150%, ND rating: 0 to 220%, HD rating: 0 to 280%). Whether to use the stall prevention or not can be selected. (V/F control, Advanced magnetic flux vector control)
	Torque limit level		Torque limit value can be set (0 to 400% variable). (Real sensorless vector control, vector control ¹ , PM sensorless vector control)
Communication specification		Built-in CC-Link IE Field Network communication function	
Operation specifications	Frequency setting signal	Analog input	Terminals 2 and 4: 0 to 10 V, 0 to 5 V, 4 to 20 mA (0 to 20 mA) are available. Terminal 1: -10 to +10 V, -5 to 5 V are available.
		Digital input	Input using the setting dial of the operation panel or parameter unit Four-digit BCD or 16-bit binary (when used with option FR-A8AX)
	Start signal		Forward and reverse rotation or start signal automatic self-holding input (3-wire input) can be selected.
	Input signals (twelve terminals)		Low-speed operation command, Middle-speed operation command, High-speed operation command, Second function selection, Terminal 4 input selection, Jog operation selection, Selection of automatic restart after instantaneous power failure, flying start, Output stop, Start self-holding selection, Forward rotation command, Reverse rotation command, Inverter reset The input signal can be changed using Pr.178 to Pr.189 (input terminal function selection) .
	Pulse train input		100k pulses/s
	Operational functions		Maximum and minimum frequency settings, multi-speed operation, acceleration/deceleration pattern, thermal protection, DC injection brake, starting frequency, JOG operation, output stop (MRS), stall prevention, regeneration avoidance, increased magnetic excitation deceleration, frequency jump, rotation display, automatic restart after instantaneous power failure, electronic bypass sequence, remote setting, automatic acceleration/deceleration, retry function, carrier frequency selection, fast-response current limit, forward/reverse rotation prevention, operation mode selection, slip compensation, droop control, load torque high-speed frequency control, speed smoothing control, traverse, auto tuning, applied motor selection, gain tuning, RS-485 communication, PID control, PID pre-charge function, easy dancer control, cooling fan operation selection, stop selection (deceleration stop/coasting), power failure time deceleration-to-stop function, stop-on-contact control, PLC function, life diagnosis, maintenance timer, current average monitor, multiple rating, orientation control ¹ , speed control, torque control, position control, pre-excitation, torque limit, test run, 24 V power supply input for control circuit, safety stop function, vibration control
	Output signal		
	Open collector output (five terminals)		Inverter running, Up to frequency, Overload warning, Output frequency detection, Fault The output signal can be changed using Pr.190 to Pr.196 (output terminal function selection) .
	Relay output (two terminals)		Fault codes of the inverter can be output (4 bits) from the open collector.
	Pulse train output		50k pulses/s
Indication	For meter	Pulse train output (FM type)	Max. 2.4 kHz: one terminal (output frequency) The monitored item can be changed using Pr.54 FM/CA terminal function selection .
		Current output (CA type)	Max. 20 mADC: one terminal (output frequency) The monitored item can be changed using Pr.54 FM/CA terminal function selection .
		Voltage output	Max. 10 VDC: one terminal (output frequency) The monitored item can be changed using Pr.158 AM terminal function selection .
	Operation panel (FR-DU08)	Operating status	Output frequency, output current, output voltage, frequency setting value The monitored item can be changed using Pr.52 Operation panel main monitor selection .
Fault record		Fault record is displayed when a fault occurs. Past 8 fault records and the conditions immediately before the fault (output voltage/current/frequency/cumulative energization time/year/month/date/time) are saved.	

Common specifications

Protective/ warning function	Protective function	Overcurrent trip during acceleration, Overcurrent trip during constant speed, Overcurrent trip during deceleration or stop, Regenerative overvoltage trip during acceleration, Regenerative overvoltage trip during constant speed, Regenerative overvoltage trip during deceleration or stop, Inverter overload trip (electronic thermal relay function), Motor overload trip (electronic thermal relay function), Heat sink overheat, Stall prevention stop, Loss of synchronism detection*4, Upper limit fault detection, Lower limit fault detection, Output side earth (ground) fault overcurrent, Output phase loss, External thermal relay operation*4, PTC thermistor operation*4, Option fault, Communication option fault, Parameter storage device fault (control circuit board), PU disconnection, Retry count excess*4, Parameter storage device fault (main circuit board), CPU fault, Operation panel power supply short circuit/RS-485 terminals power supply short circuit, 24 VDC power fault, Abnormal output current detection*4, Communication fault (inverter), Analog input fault, USB communication fault, Safety circuit fault, Overspeed occurrence*4, Speed deviation excess detection*1*4, Signal loss detection*1*4, Excessive position fault*1*4, Brake sequence fault*4, Encoder phase fault*1*4, 4 mA input fault*4, Pre-charge fault*4, PID signal fault*4, Option fault, Opposite rotation deceleration fault*4, Internal circuit fault, Magnetic pole position unknown*1, External fault during output operation*4
	Warning function	Fan alarm, Stall prevention (overcurrent), Stall prevention (overvoltage), Electronic thermal relay function pre-alarm, PU stop, Speed limit indication (output during speed limit)*4, Parameter copy, Safety stop, Maintenance timer 1 to 3*4, USB host error, Home position return setting error*4, Home position return uncompleted*4, Home position return parameter setting error*4, Operation panel lock*4, Password locked*4, Parameter write error, Copy operation error, 24 V external power supply operation, Continuous operation during communication fault, Load fault warning
Environment	Surrounding air temperature	0°C to +50°C (non-freezing) (LD, ND, HD ratings) 0°C to +40°C (non-freezing) (SLD rating)
	Surrounding air humidity	95% RH or less (non-condensing) (With circuit board coating (conforming to IEC60721-3-3 3C2/3S2), IP55 compatible models) 90% RH or less (non-condensing) (Without circuit board coating)
	Storage temperature*3	-20°C to +65°C
	Atmosphere	Indoors (without corrosive gas, flammable gas, oil mist, dust and dirt, etc.)
	Altitude/vibration	Maximum 2500 m (For the installation in an altitude above 1000 m, derate the rated current 3% per 500 m.) • 2.9 m/s ² or less at 10 to 55 Hz (directions of X, Y, Z axes)

*1 Available only when a vector control compatible option is mounted.

*2 In the initial setting, it is limited to 150% by the torque limit level.

*3 Temperature applicable for a short time, e.g. in transit.

*4 This protective function is not available in the initial status.

6.3 Outline dimension drawings

FR-A842-07700(315K), FR-A842-08660(355K)

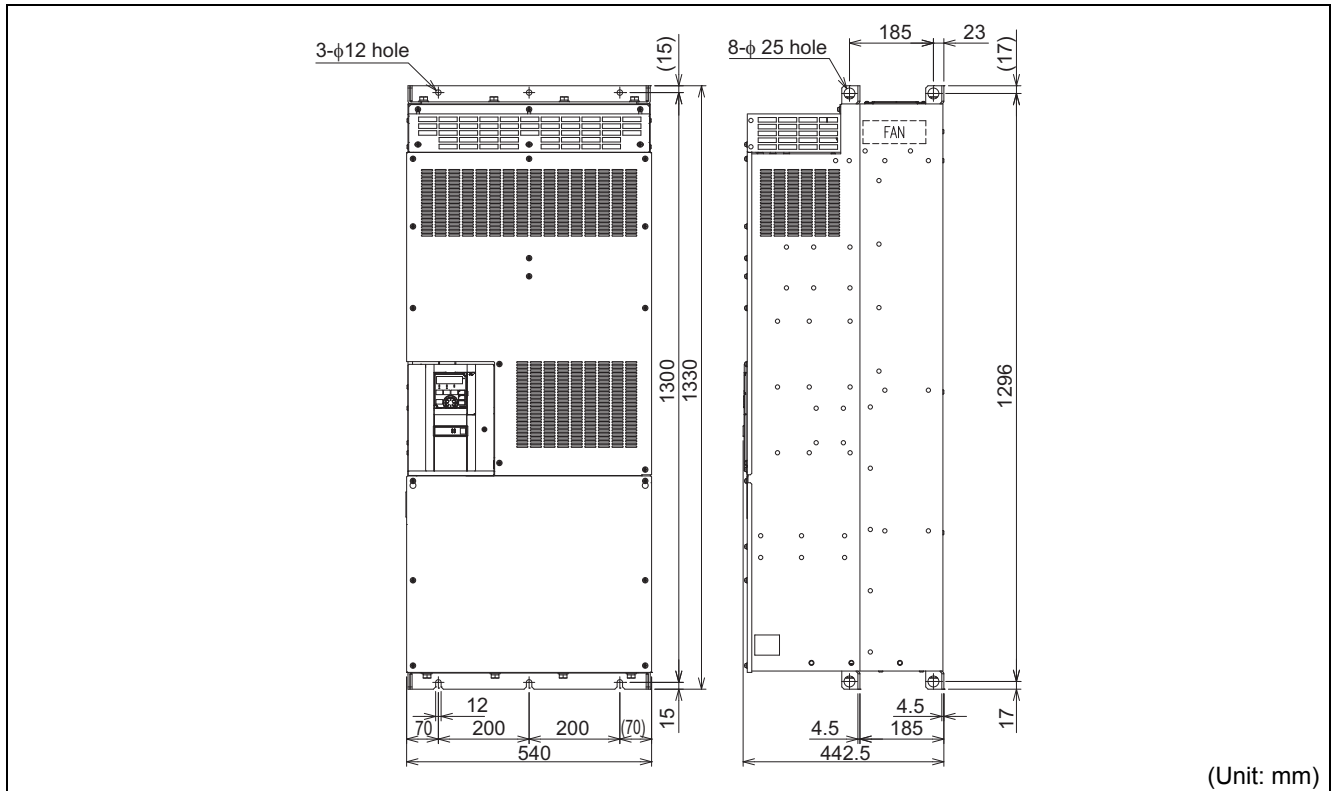

FR-A842-09620(400K), FR-A842-10940(450K), FR-A842-12120(500K)

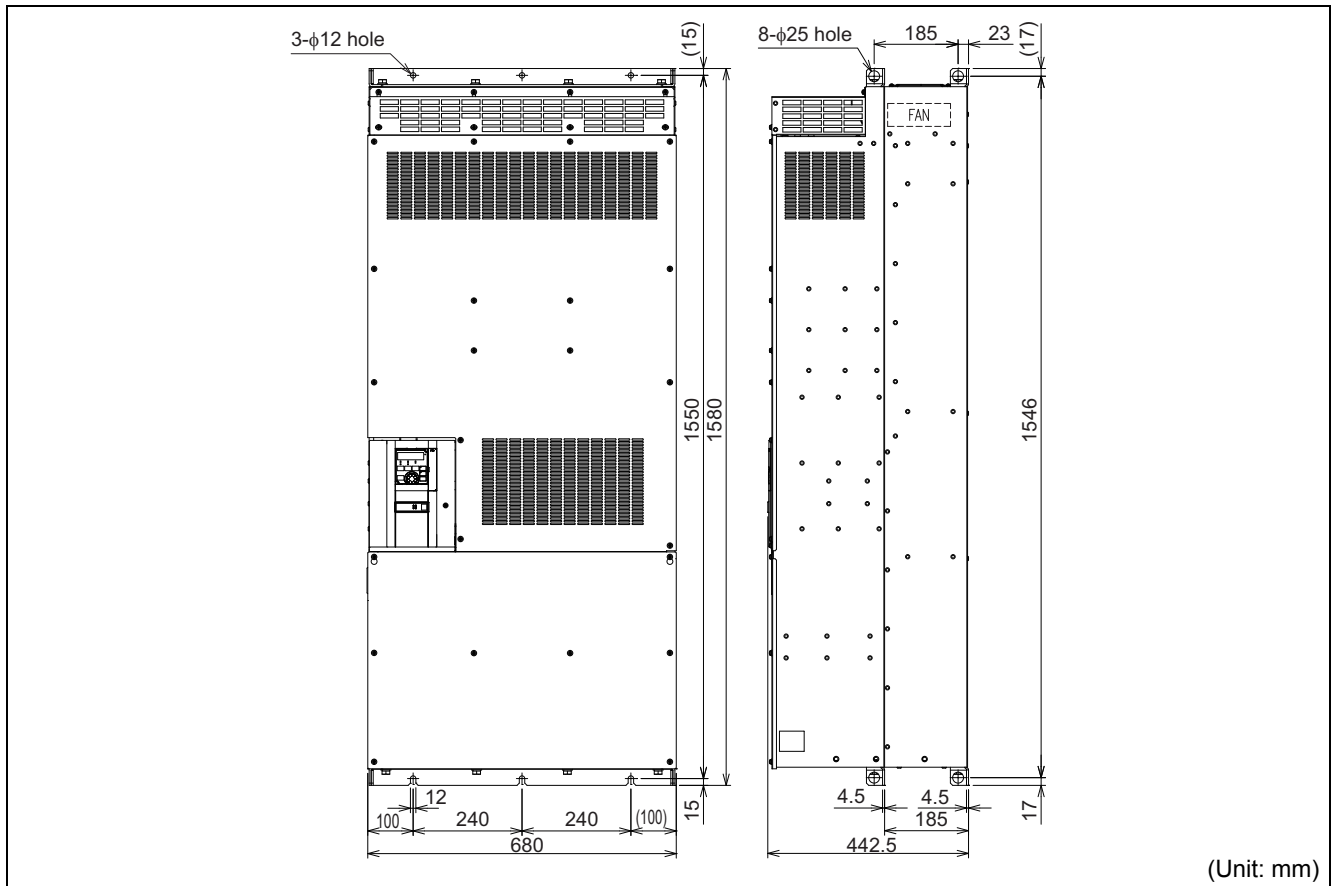

Outline dimension drawings

Operation panel (FR-DU08, FR-LU08)

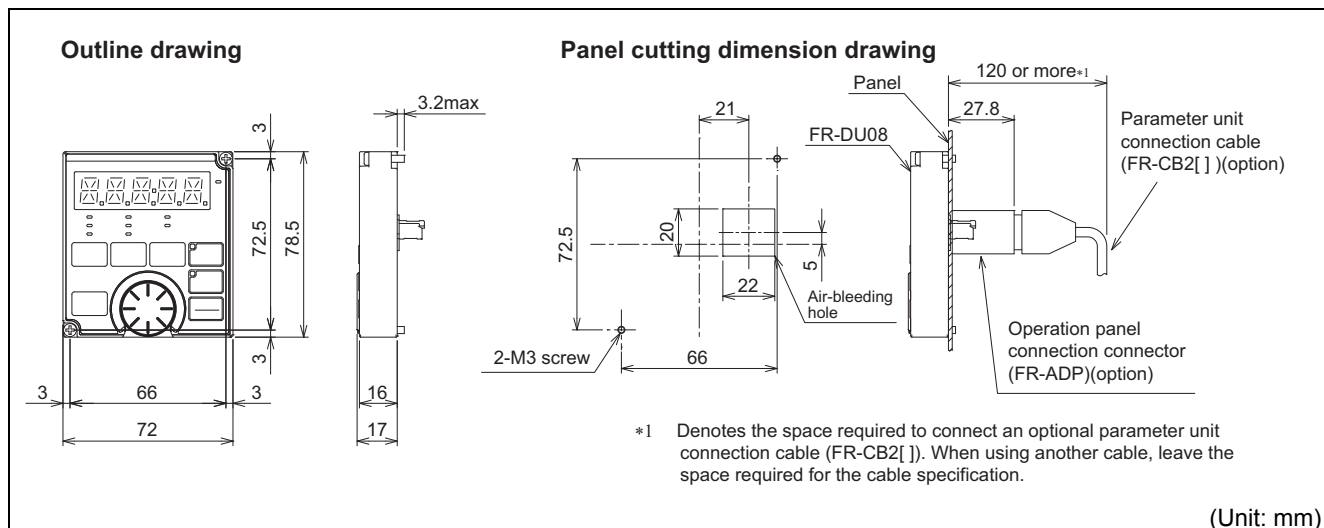



APPENDIX

**APPENDIX provides the reference information for use of this product.
Refer to APPENDIX as required.**

Appendix 1 For customers replacing the conventional model with this inverter	112
Appendix 2 Comparison with FR-A840	114
Appendix 3 Instructions for compliance with the EU Directives ..	115
Appendix 4 Instructions for UL and cUL	118
Appendix 5 Instructions for EAC	120
Appendix 6 Restricted Use of Hazardous Substances in Electronic and Electrical Products	121
Appendix 7 Referenced Standard (Requirement of Chinese standardized law)	121

Appendix 1 For customers replacing the conventional model with this inverter

Appendix 1.1 Replacement of the FR-A740 series

◆ Difference and compatibility with FR-A740 series

Item		FR-A740	FR-A842
Control method		V/F control Advanced magnetic flux vector control Real sensorless vector control Vector control (with plug-in option used) PM sensorless vector control (IPM motor)	V/F control Advanced magnetic flux vector control Real sensorless vector control Vector control (with plug-in option / control terminal option) PM sensorless vector control (IPM motor/SPM motor)
Added functions		-	USB host function Safety stop function etc.
Maximum output frequency	V/F control	400 Hz	590 Hz
	Advanced magnetic flux vector control	120 Hz	400 Hz
	Real sensorless vector control	120 Hz	400 Hz
	Vector control	120 Hz	400 Hz
	PM sensorless vector control (MM-CF)	300 Hz	400 Hz
PID control		Turn the X14 signal ON to enable PID control.	When the X14 signal is not assigned, just set a value in Pr.128 to enable PID control. When the X14 signal is assigned, turn the X14 signal ON while Pr.128 ≠ "0" to enable PID control. The PID pre-charge function and dancer control are added.
Automatic restart after instantaneous power failure		Turn the CS signal ON to restart.	CS signal assignment not required. (Restart is enabled with the Pr.57 setting only.)
Number of motor poles V/F control switching		The V/F switchover (X18) signal is valid when Pr.81 = "12 to 20 (2 to 10 poles)".	Pr.81 = "12 (12 poles)" X18 is valid regardless of the Pr.81 setting. (The Pr.81 settings "14 to 20" are not available.)
PTC thermistor input		Input from the terminal AU (The function of the terminal AU is switched by a switch.)	Input from the terminal 2. (The function of the terminal 2 is switched by the Pr.561 setting.)
USB connector		B connector	Mini B connector
Control circuit terminal block		Removable terminal block (screw type)	Removable terminal block (spring clamp type)
Terminal response level		The FR-A800's I/O terminals have better response level than the FR-A700's terminals. By setting Pr.289 Inverter output terminal filter and Pr.699 Input terminal filter , the terminal response level can be compatible with that of FR-A700. Set to approximately 5 to 8 ms and adjust the setting according to the system.	
PU		FR-DU07 (4-digit LED) FR-PU07	FR-DU08 (5-digit LED) FR-LU08 (LCD operation panel) FR-PU07 (Some functions are unavailable.) FR-DU07 is not supported.
Plug-in option		Dedicated plug-in options (not interchangeable)	
Communication option		Connected to the connector 3.	Connected to the connector 1.
Installation size		Installation size is not compatible. (New mounting holes are required.)	
Converter		Built in for all capacities	The converter unit (FR-CC2) is required.
DC reactor		DC reactor (FR-HEL) is provided.	Built in the converter unit (FR-CC2)
Brake unit		FR-BU2, FR-BU5	FR-BU2

◆ Installation precautions

- Removal procedure of the front cover is different. (Refer to [page 15](#).)
- Plug-in options of the FR-A700 series are not compatible.
- Operation panel (FR-DU07) cannot be used.

◆ Wiring precautions

- The spring clamp type terminal block has changed to the screw type. Use of blade terminals is recommended.

◆ Instructions for continuous use of the FR-PU07 (parameter unit) manufactured in September 2015 or earlier

- For the FR-A800 series, many functions (parameters) have been added. When setting these parameters, the parameter names and setting ranges are not displayed.
- Only the parameter with the numbers up to "999" can be read and set. The parameters with the numbers after "999" cannot be read or set.
- Many protective functions have been added for the FR-A800 series. These functions are available, but all faults are displayed as "Fault". When the fault history is checked, "ERR" appears. Added faults will not appear on the parameter unit. (However, MT1 to MT3 are displayed as MT.)
- Parameter copy/verification function are not available.

◆ Copying parameter settings

- The FR-A700 series' parameter setting can be easily copied to the FR-A800 series by using the setup software (FR Configurator2). (Not supported by the the setup software FR-SW3-SETUP or older.)

Appendix 1.2 Replacement of the FR-A500(L) series

◆ Installation precautions

- Installation size is not compatible. (New mounting holes are required.)
- The optional converter unit (FR-CC2) is required.

Appendix 2 Comparison with FR-A840

Item	FR-A840	FR-A842
Pr.30 Regenerative function selection	Setting ranges "0 to 2, 10, 11, 20, 21, 100 to 102, 110, 111, 120, 121" Initial value "0"	Setting ranges "2, 10, 11, 102, 110, 111" Initial value "10"
Pr.70 Special regenerative brake duty	With the parameter	Without the parameter
Monitor function (Pr.52, Pr.54, Pr.158, Pr.774 to Pr.776, Pr.992, Pr.1027 to Pr.1034)	Regenerative brake duty With (Acceptable)	Regenerative brake duty Without (Unacceptable)
Input terminal function selection (Pr.178 to Pr.189)	DC feeding operation permission (X70), DC feeding cancel (X71) With (Acceptable)	DC feeding operation permission (X70), DC feeding cancel (X71) Without (Unacceptable)
Pr.187 MRS terminal function selection	Initial value "24" (MRS)	Initial value "10" (X10)
Output terminal function selection (Pr.190 to Pr.196, Pr.313 to Pr.322)	Instantaneous power failure/undervoltage (IPF), Regenerative brake pre-alarm (RBP), DC current feeding (Y85), Main circuit capacitor life (Y87), Inrush current limit circuit life (Y89) With (Acceptable)	Instantaneous power failure/undervoltage (IPF), Regenerative brake pre-alarm (RBP), DC current feeding (Y85), Main circuit capacitor life (Y87), Inrush current limit circuit life (Y89) Without (Unacceptable)
Pr.192 IPF terminal function selection	Initial value "2" (IPF)	Initial value "9999" (No function)
Inrush current limit circuit life display, Main circuit capacitor life display (Pr.256, Pr.258, Pr.259)	With the parameter	Without the parameter
Pr.599 X10 terminal input selection	Initial value "0" (NO contact specification)	Initial value "1" (NC contact specification)
Pr.872 Input phase loss protection selection	With the parameter	Without the parameter
Warning, protective functions	Regenerative brake pre-alarm (RB), Instantaneous power failure (E.IPF), Undervoltage (E.UVT), Input phase loss (E.ILF), Brake transistor alarm detection (E.BE), Inrush current limit circuit fault (E.IOH) Available	Regenerative brake pre-alarm (RB), Instantaneous power failure (E.IPF), Undervoltage (E.UVT), Input phase loss (E.ILF), Brake transistor alarm detection (E.BE), Inrush current limit circuit fault (E.IOH) Not available

Appendix 3 Instructions for compliance with the EU Directives

The EU Directives are issued to standardize different national regulations of the EU Member States and to facilitate free movement of the equipment, whose safety is ensured, in the EU territory.

Since 1996, compliance with the EMC Directive that is one of the EU Directives has been legally required. Since 1997, compliance with the Low Voltage Directive, another EU Directive, has been also legally required. When a manufacturer confirms its equipment to be compliant with the EMC Directive and the Low Voltage Directive, the manufacturer must declare the conformity and affix the CE marking.

- The authorized representative in the EU

The authorized representative in the EU is shown below.

Company name: Mitsubishi Electric Europe B.V.

Address: Mitsubishi-Electric-Platz 1, 40882 Ratingen, Germany

◆ EMC Directive

We declare that this inverter conforms with the EMC Directive and affix the CE marking on the inverter.

- EMC Directive: 2014/30/EU
- Standard(s): EN 61800-3:2004+A1:2012 (Second environment / PDS Category "C3")
- This inverter is not intended to be used on a low-voltage public network which supplies domestic premises. When using the inverter in a residential area, take appropriate measures and ensure the conformity of the inverter used in the residential area.
- The installer shall provide a guide for installation and use, including recommended mitigation devices.

Note:

First environment

Environment including buildings/facilities which are directly connected to a low voltage main supply which also supplies residential buildings. Directly connected means that there is no intermediate transformer between these buildings.

Second environment

Environment including all buildings/facilities which are not directly connected to a low voltage main supply which also supplies residential buildings.

◆ Note

Ensure the EMC filter is enabled, install the product as stated below, and then carry out any wiring.

- The converter unit is equipped with an EMC filter (Class C3). Enable the EMC filter. (For details, refer to [page 74](#).)
- Connect the inverter and the converter unit to an earthed (grounded) power supply.
- Install the motor and controller cable found in the EMC Installation Manual (BCN-A21041-204) and Technical News (MFS-113) according to the instructions.
- To make full use of the built-in EMC filter, motor cable lengths should not exceed 20 m.
- Confirm that the final application conforms with the required EMC standard.

◆ Low Voltage Directive

We have self-confirmed our inverters as products compliant to the Low Voltage Directive and affix the CE marking on the inverters.

- Low Voltage Directive: 2014/35/EU
- Conforming standard: EN 61800-5-1:2007

◆ Outline of instructions

- Do not use an earth leakage current breaker as an electric shock protector without connecting the equipment to the earth. Connect the equipment to the earth (ground) securely.
- Wire the earth terminal independently. (Do not connect two or more cables to one terminal.)
- Use the cable sizes on [page 32](#) under the following conditions.
 - Surrounding air temperature 40°C maximum
- If conditions are different from above, select appropriate wire according to EN 60204-1 and IEC 60364-5-52.
- Use a tinned (plating should not include zinc) crimping terminal to connect the earth (ground) cable. When tightening the screw, be careful not to damage the threads.
- For use as a product compliant with the Low Voltage Directive, use PVC cable whose size is indicated on [page 32](#).
- Use the molded case circuit breaker and magnetic contactor which conform to the EN or IEC Standard.
- DC current may flow from the inverter to a protective earth (ground) conductor. When using a residual current device (RDC) or residual current monitor (RDM), connect a type B RCD or RCM to the power supply side.
- Use the inverter under the conditions of overvoltage category II (usable regardless of the earth (ground) condition of the power supply), overvoltage category III (usable with the earthed-neutral system power supply, 400 V class only) and pollution degree 2 or lower specified in IEC60664.
 - To use the inverter under the conditions of pollution degree 2, install it in the enclosure of IP2X or higher.
 - To use the inverter under the conditions of pollution degree 3, install it in the enclosure of IP54 or higher.
- On the input and output of the inverter and the converter unit, use cables of the type and size set forth in EN 60204-1 and IEC 60364-5-52.
- The operating capacity of the relay outputs (terminal symbols A1, B1, C1, A2, B2, C2) should be 30 VDC, 0.3 A. (Relay output has basic isolation from the internal circuit of the inverter and the converter unit.)
- Control circuit terminals on [page 26](#) are safely isolated from the main circuit.
- Environment (For the detail, refer to [page 17](#).)

	During operation	In storage	During Transportation
Surrounding air temperature	LD, ND (initial setting), HD: 0°C to +50°C SLD: 0°C to +40°C	-20 to +65°C	-20 to +65°C
Ambient humidity	95%RH or less	95%RH or less	95%RH or less
Maximum altitude	2500 m*1	2500 m	10000 m

*1 For installation at an altitude above 1000 m, consider a 3% reduction in the rated current per 500 m increase in altitude.

◆ Wiring protection

Class T, Class J, Class CC, or Class L fuses must be provided.
(Use a product which conforms to the EN or IEC Standard.)

FR-CC2-[]	H315K	H355K	H400K	H450K	H500K	H560K	H630K
Rated fuse voltage (V)	500 V or more						
Fuse allowable rating (A)	1100	1200	1350	1500	1800	1800	1800

◆ Short circuit ratings

Suitable For Use in A Circuit Capable of Delivering Not More Than 100 kA rms Symmetrical Amperes, 500 V Maximum.

◆ Motor overload protection

When using the electronic thermal relay function as motor overload protection, set the rated motor current in **Pr.9 Electronic thermal O/L relay**.

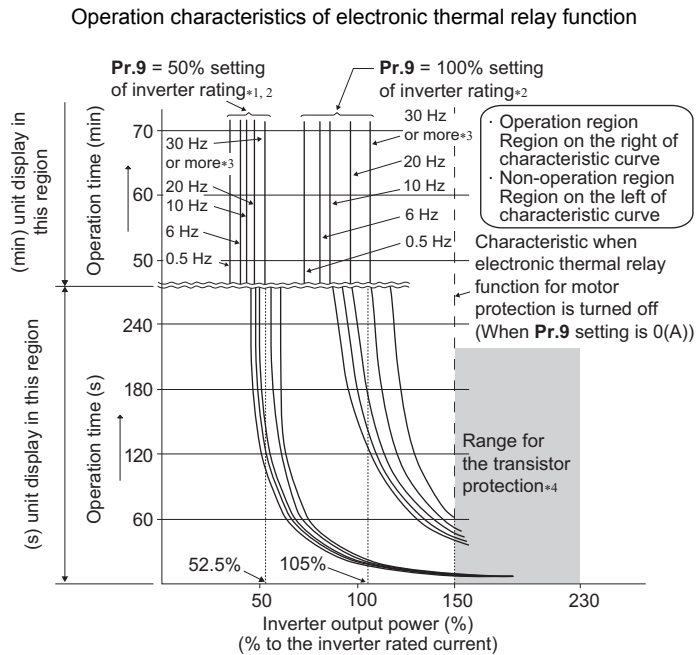

This function detects the overload of the motor and trips the inverter by stopping the operation of the transistor at the inverter output side. (The operation characteristic is shown on the left.)

- When using the Mitsubishi Electric constant-torque motor

- (1) Set one of "1", "13" to "16" in **Pr.71**. (This setting will enable the 100% constant-torque characteristic in the low-speed range.)
- (2) Set the rated current of the motor in **Pr.9**.

- *1 When a value 50% of the inverter rated output current (current value) is set in **Pr.9**
- *2 The % value denotes the percentage to the rated inverter current. It is not the percentage to the rated motor current.
- *3 When you set the electronic thermal relay function dedicated to the Mitsubishi Electric constant-torque motor, this characteristic curve applies to operation at 6 Hz or higher.
- *4 Transistor protection is activated depending on the temperature of the heatsink. The protection may be activated even with less than 150% depending on the operating conditions.

NOTE

- The internal accumulated heat value of the electronic thermal relay function is reset by inverter power reset and reset signal input. Avoid unnecessary reset and power-OFF.
- Install an external thermal relay (OCR) between the inverter and motors to operate several motors, a multi-pole motor or a dedicated motor with one inverter. Note that the current indicated on the motor rating plate is affected by the line-to-line leakage current (refer to Instruction Manual (Detailed)) when selecting the setting for an external thermal relay.
- The cooling effect of the motor drops during low-speed operation. Use a thermal protector or a motor with built-in thermistor.
- When the difference between the inverter and motor capacities is large and the setting is small, the protective characteristics of the electronic thermal relay function will be deteriorated. In such case, use an external thermal relay.
- A dedicated motor cannot be protected by an electronic thermal O/L relay. Use an external thermal relay.
- Motor over temperature sensing is not provided by the drive.
- The electronic thermal memory retention function is not provided by the drive.

Appendix 4 Instructions for UL and cUL

(Standard to comply with: UL 508C, CSA C22.2 No.274-13)

◆ General Precaution

CAUTION - Risk of Electric Shock -

The bus capacitor discharge time is 10 minutes. Before starting wiring or inspection, switch power off, wait for more than 10 minutes, and check for residual voltage between terminal P/+ and N/- with a meter etc., to avoid a hazard of electrical shock.

ATTENTION - Risque de choc électrique -

La durée de décharge du condensateur de bus est de 10 minutes. Avant de commencer le câblage ou l'inspection, mettez l'appareil hors tension et attendez plus de 10 minutes.

◆ Installation

The FR-A802 inverters with the below types of converter unit have been approved as products for use in enclosure. Design the enclosure so that the surrounding air temperature, humidity and ambience of the inverter will satisfy the specifications. (Refer to [page 17](#).)

◆ Branch circuit protection

For installation in the United States, Class T, Class J, Class CC, or Class L fuse must be provided, in accordance with the National Electrical Code and any applicable local codes.

For installation in Canada, Class T, Class J, Class CC, or Class L fuse must be provided, in accordance with the Canadian Electrical Code and any applicable local codes.

FR-CC2-[]	H315K	H355K	H400K	H450K	H500K	H560K	H630K
Rated fuse voltage (V)	500 V or more						
Fuse allowable rating (A)	1100	1200	1350	1500	1800	1800	1800

◆ Wiring to the power supply and the motor

Refer to the National Electrical Code (Article 310) regarding the allowable current of the cable. Select the cable size for 125% of the rated current according to the National Electrical Code (Article 430).

For wiring the input (R/L1, S/L2, T/L3) terminals of the converter unit and output (U, V, W) terminals of the inverter, use the UL listed copper, stranded wires (rated at 75°C) and round crimping terminals. Crimp the crimping terminals with the crimping tool recommended by the terminal maker.

◆ Short circuit ratings

Suitable For Use in A Circuit Capable of Delivering Not More Than 100 kA rms Symmetrical Amperes, 500 V Maximum.

◆ Motor overload protection

When using the electronic thermal relay function as motor overload protection, set the rated motor current in **Pr.9 Electronic thermal O/L relay**.

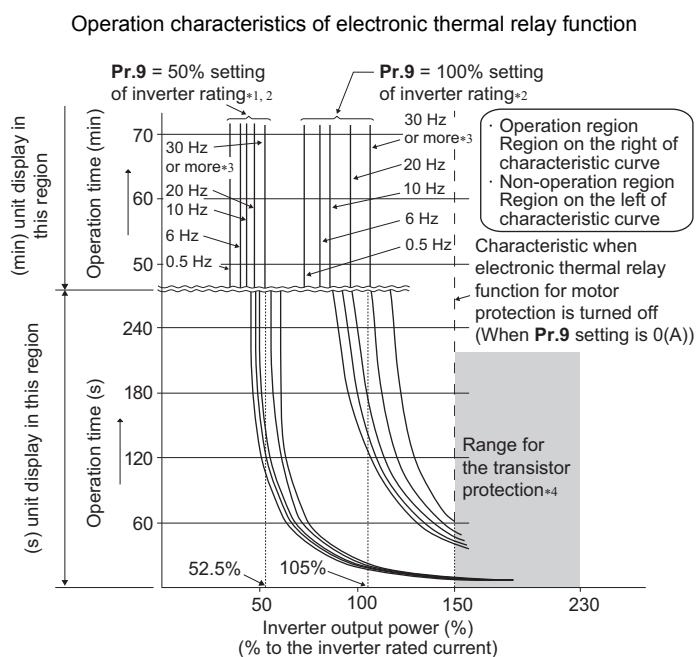

This function detects the overload (overheat) of the motor and trips the inverter by stopping the operation of the transistor at the inverter output side. (The operation characteristic is shown on the left.)

- When using the Mitsubishi Electric constant-torque motor

- (1) Set one of "1", "13" to "16" in **Pr.71**. (This setting will enable the 100% constant-torque characteristic in the low-speed range.)
- (2) Set the rated current of the motor in **Pr.9**.

- *1 When a value 50% of the inverter rated output current (current value) is set in **Pr.9**
- *2 The % value denotes the percentage to the rated inverter current. It is not the percentage to the rated motor current.
- *3 When you set the electronic thermal relay function dedicated to the Mitsubishi Electric constant-torque motor, this characteristic curve applies to operation at 6 Hz or higher.
- *4 Transistor protection is activated depending on the temperature of the heatsink. The protection may be activated even with less than 150% depending on the operating conditions.

NOTE

- The internal accumulated heat value of the electronic thermal relay function is reset by inverter power reset and reset signal input. Avoid unnecessary reset and power-OFF.
- Install an external thermal relay (OCR) between the inverter and motors to operate several motors, a multi-pole motor or a dedicated motor with one inverter. Note that the current indicated on the motor rating plate is affected by the line-to-line leakage current (refer to Instruction Manual (Detailed)) when selecting the setting for an external thermal relay.
- The cooling effect of the motor drops during low-speed operation. Use a thermal protector or a motor with built-in thermistor.
- When the difference between the inverter and motor capacities is large and the setting is small, the protective characteristics of the electronic thermal relay function will be deteriorated. In such case, use an external thermal relay.
- A dedicated motor cannot be protected by an electronic thermal O/L relay. Use an external thermal relay.
- Motor over temperature sensing is not provided by the drive.

Appendix 5 Instructions for EAC

EAC

The product certified in compliance with the Eurasian Conformity has the EAC marking.

Note: EAC marking

In 2010, three countries (Russia, Belarus, and Kazakhstan) established a Customs Union for the purposes of revitalizing the economy by forming a large economic bloc by abolishing or reducing tariffs and unifying regulatory procedures for the handling of articles.

Products to be distributed over these three countries of the Customs Union must comply with the Customs Union Technical Regulations (CU-TR), and the EAC marking must be affixed to the products.

For information on the country of origin, manufacture year and month, and authorized sales representative (importer) in the CU area of this product, refer to the following:

- Country of origin indication
Check the rating plate of the product. (Refer to [page 8](#).)
Example: MADE IN JAPAN
- Manufactured year and month
Check the SERIAL number indicated on the rating plate of the product. (Refer to [page 8](#).)
- Authorized sales representative (importer) in the CU area
The authorized sales representative (importer) in the CU area is shown below.
Name: Mitsubishi Electric (Russia) LLC
Address: 52, bld 1 Kosmodamianskaya Nab 115054, Moscow, Russia
Phone: +7 (495) 721-2070
Fax: +7 (495) 721-2071

Appendix 6 Restricted Use of Hazardous Substances in Electronic and Electrical Products

The mark of restricted use of hazardous substances in electronic and electrical products is applied to the product as follows based on the "Management Methods for the Restriction of the Use of Hazardous Substances in Electrical and Electronic Products" of the People's Republic of China.

电器电子产品有害物质限制使用标识要求

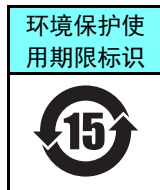

本产品中所含有的有害物质的名称、含量、含有部件如下表所示。

- 产品中所含有害物质的名称及含量

部件名称 *2	有害物质 *1					
	铅 (Pb)	汞 (Hg)	镉 (Cd)	六价铬 (Cr (VI))	多溴联苯 (PBB)	多溴二苯醚 (PBDE)
电路板组件 (包括印刷电路板及其构成的零部件, 如电阻、电容、集成电路、连接器等)、电子部件	×	○	×	○	○	○
金属壳体、金属部件	×	○	○	○	○	○
树脂壳体、树脂部件	○	○	○	○	○	○
螺丝、电线	○	○	○	○	○	○

上表依据 SJ/T11364 的规定编制。

○: 表示该有害物质在该部件所有均质材料中的含量均在 GB/T26572 规定的限量要求以下。

×: 表示该有害物质在该部件的至少一种均质材料中的含量超出 GB/T26572 规定的限量要求。

*1 即使表中记载为 ×, 根据产品型号, 也可能会有有害物质的含量为限制值以下的情况。

*2 根据产品型号, 一部分部件可能不包含在产品中。

Appendix 7 Referenced Standard (Requirement of Chinese standardized law)

This Product is designed and manufactured accordance with following Chinese standards.

Machinery safety : GB/T 16855.1
 GB/T 12668.502
 GB 28526
 GB/T 12668.3
 Electrical safety : GB/T 12668.501
 EMC : GB/T 12668.3

WARRANTY

When using this product, make sure to understand the warranty described below.

1. Warranty period and coverage

We will repair any failure or defect (hereinafter referred to as "failure") in our FA equipment (hereinafter referred to as the "Product") arisen during warranty period at no charge due to causes for which we are responsible through the distributor from which you purchased the Product or our service provider. However, we will charge the actual cost of dispatching our engineer for an on-site repair work on request by customer in Japan or overseas countries. We are not responsible for any on-site readjustment and/or trial run that may be required after a defective unit are repaired or replaced.

[Term]

The term of warranty for Product is twelve months after your purchase or delivery of the Product to a place designated by you or eighteen months from the date of manufacture whichever comes first ("Warranty Period"). Warranty period for repaired Product cannot exceed beyond the original warranty period before any repair work.

[Limitations]

- (1) You are requested to conduct an initial failure diagnosis by yourself, as a general rule. It can also be carried out by us or our service company upon your request and the actual cost will be charged.
However, it will not be charged if we are responsible for the cause of the failure.
- (2) This limited warranty applies only when the condition, method, environment, etc. of use are in compliance with the terms and conditions and instructions that are set forth in the instruction manual and user manual for the Product and the caution label affixed to the Product.
- (3) Even during the term of warranty, the repair cost will be charged on you in the following cases;
 - a failure caused by your improper storing or handling, carelessness or negligence, etc., and a failure caused by your hardware or software problem
 - a failure caused by any alteration, etc. to the Product made on your side without our approval
 - a failure which may be regarded as avoidable, if your equipment in which the Product is incorporated is equipped with a safety device required by applicable laws and has any function or structure considered to be indispensable according to a common sense in the industry
 - a failure which may be regarded as avoidable if consumable parts designated in the instruction manual, etc. are duly maintained and replaced
 - any replacement of consumable parts (condenser, cooling fan, etc.)
 - a failure caused by external factors such as inevitable accidents, including without limitation fire and abnormal fluctuation of voltage, and acts of God, including without limitation earthquake, lightning and natural disasters
 - a failure generated by an unforeseeable cause with a scientific technology that was not available at the time of the shipment of the Product from our company
 - any other failures which we are not responsible for or which you acknowledge we are not responsible for

2. Term of warranty after the stop of production

- (1) We may accept the repair at charge for another seven (7) years after the production of the product is discontinued. The announcement of the stop of production for each model can be seen in our Sales and Service, etc.
- (2) Please note that the Product (including its spare parts) cannot be ordered after its stop of production.

3. Service in overseas

Our regional FA Center in overseas countries will accept the repair work of the Product; however, the terms and conditions of the repair work may differ depending on each FA Center. Please ask your local FA center for details.

4. Exclusion of responsibility for compensation against loss of opportunity, secondary loss, etc.

Regardless of the gratis warranty term, Mitsubishi Electric shall not be liable for compensation to:

- (1) Damages caused by any cause found not to be the responsibility of Mitsubishi Electric.
- (2) Loss in opportunity, lost profits incurred to the user by Failures of Mitsubishi Electric products.
- (3) Special damages and secondary damages whether foreseeable or not, compensation for accidents, and compensation for damages to products other than Mitsubishi Electric products.
- (4) Replacement by the user, maintenance of on-site equipment, start-up test run and other tasks.

5. Change of Product specifications

Specifications listed in our catalogs, manuals or technical documents may be changed without notice.

6. Application and use of the Product

- (1) For the use of our product, its applications should be those that may not result in a serious damage even if any failure or malfunction occurs in product, and a backup or fail-safe function should operate on an external system to product when any failure or malfunction occurs.
- (2) Our product is designed and manufactured as a general purpose product for use at general industries.
Therefore, applications substantially influential on the public interest for such as atomic power plants and other power plants of electric power companies, and also which require a special quality assurance system, including applications for railway companies and government or public offices are not recommended, and we assume no responsibility for any failure caused by these applications when used.
In addition, applications which may be substantially influential to human lives or properties for such as airlines, medical treatments, railway service, incineration and fuel systems, man-operated material handling equipment, entertainment machines, safety machines, etc. are not recommended, and we assume no responsibility for any failure caused by these applications when used.
We will review the acceptability of the abovementioned applications, if you agree not to require a specific quality for a specific application. Please contact us for consultation.

◆ About the enclosed CD-ROM

The enclosed CD-ROM contains PDF copies of the manuals related to this product.

◆ Before using the enclosed CD-ROM

- The copyright and other rights of the enclosed CD-ROM all belong to Mitsubishi Electric Corporation.
- No part of the enclosed CD-ROM may be copied or reproduced without the permission of Mitsubishi Electric Corporation.
- Specifications of the enclosed CD-ROM are subject to change for modification without notice.
- We are not responsible for any damages and lost earnings, etc. from use of the enclosed CD-ROM.
- Trademarks

Microsoft, Windows, and Internet Explorer are either registered trademarks or trademarks of Microsoft Corporation in the United States and/or other countries.

Windows Vista is either registered trademarks or trademark of Microsoft Corporation in the United States and/or other countries.

Adobe and Acrobat Reader are either registered trademarks or trademarks of Adobe Systems Incorporated in the United States and/or other countries.

Intel and Pentium are trademarks of Intel Corporation in the United States and/or other countries.

Any trade names and product names of companies herein are all trademarks or registered trademarks of those respective companies.

- Warranty

We do not provide a warranty against defects in the enclosed CD-ROM and related documents.



- This is a personal computer dedicated CD-ROM. Do not attempt to play it on ordinary audio devices. The loud volume may damage hearing and speakers.

◆ System requirements for the enclosed CD-ROM

- The following system is required to read instruction manuals contained in the enclosed CD-ROM.

Item	Specifications
OS	Microsoft® Windows® 10, Windows® 8.1, Windows® 8, Windows® 7, Windows Vista®
CPU	Intel® Pentium® or better processor
Memory	128 MB of RAM
Hard disk	90 MB of available hard-disk space
CD-ROM drive	Double speed or more (more than quadruple speed is recommended)
Monitor	800×600 dots or more
Application	Adobe® Reader® 7.0 or higher Internet Explorer® 6.0 or higher

◆ Operating method of the enclosed CD-ROM

- How to read instruction manuals

Step 1. Start the personal computer and place the enclosed CD-ROM in the CD-ROM drive.

Step 2. The main window will automatically open in the web browser.

Step 3. Choose your language from a language menu.

Step 4. Click the manual you want to read in the "INSTRUCTION MANUAL" list.

Step 5. The PDF manual will open.

- Manual opening of the enclosed CD-ROM

Step 1. Start the personal computer and place the enclosed CD-ROM in the CD-ROM drive.

Step 2. Open the "index.html" file.

Step 3. The main window will open in the web browser. Follow the previous steps from Step 3 to Step 5.

- PDF data of the instruction manual are stored in "MANUAL" folder on the enclosed CD-ROM.

REVISIONS

*The manual number is given on the bottom left of the back cover.

Revision date	*Manual Number	Revision
Aug. 2015	IB(NA)-0600602ENG-A	First edition
Jul. 2016	IB(NA)-0600602ENG-B	Modification <ul style="list-style-type: none"> • Safety stop function Addition <ul style="list-style-type: none"> • Instructions for EAC • Restricted Use of Hazardous Substances in Electronic and Electrical Products
May 2019	IB(NA)-0600602ENG-C	Addition <ul style="list-style-type: none"> • Application of caution labels • Referenced Standard (Requirement of Chinese standardized law) • Removal and reinstallation precautions of the control circuit terminal block

FR-A800/A800 Plus Series

Instruction Manual Supplement

1 Internal storage device fault (E.PE6)

The operation of the storage device in the inverter can be checked.

If a data fault occurs in the storage device in the inverter, the protective function (E.PE6) is activated.

When the read value of **Pr.890** is "7" or smaller, an inverter reset after All parameter clear can return the operation to normal. (The parameters that had been changed before All parameter clear must be set again.)

Operation panel indication	E.PE6	E. PEE	FR-LU08 indication	Fault
Name	Internal storage device fault			
Description	This protective function is activated by an inverter reset if writing data fails due to power-OFF or a data fault occurs in the storage device during parameter operations ^{*1} .			
Check point	Check if the power was turned OFF during parameter operations.			
Corrective action	Check the power supply or the devices on the power system to check that the devices have no fault. <ul style="list-style-type: none"> When E.PE6 occurs due to power-OFF during parameter operations: Check the read value of Pr.890. When the value is "7" or smaller, perform All parameter clear and then an inverter reset. The parameters that had been changed before All parameter clear must be set again. When E.PE6 occurs due to other reason (such as turning OFF/ON the power or an inverter reset): Contact your sales representative. 			

*1 For example, when parameter clear, All parameter clear, Parameter copy, or offline auto tuning is performed in the inverter, or when parameter batch write is performed in FR Configurator2.

NOTE

- "E.PE6" does not activate the retry function.
- "E.PE6" outputs the Fault output 3 (Y91) signal.
- "E.PE6" turns OFF the Safety monitor output (SAFE) signal.
- "E.PE6" is not cleared by turning ON the Fault clear (X51) signal.
- "E.PE6" is not activated during emergency drive operation.
- The communication data code for "E.PE6" is 172 (HAC).

◆ Checking faulty area in the internal storage device

When E.PE6 occurs, faulty area in the internal storage device can be checked by reading **Pr.890**.

Pr.	Name	Initial value	Setting range	Description
890 H325	Internal storage device status indication	0	(0 to 9999)	A faulty area detected by self-check function can be indicated in the internal storage device.



- Use the read value of **Pr.890** to check the faulty area.
- The following table shows faulty areas indicated by the read value of **Pr.890**. Some read values indicate that there are multiple faulty areas. (For example, the read value "7" indicates that all the areas described in No. 1 to No. 3 are faulty.)

No.	Read value	Description
1	1, 3, 5, 7	Storage area other than the area for parameter settings is faulty (such as area for the set frequency). (When All parameter clear is performed, the set frequency, remotely-set frequency, host name for Ethernet communication, position pulse, multi-revolution counter, and offline auto tuning data are cleared.)
2	2, 3, 6, 7	Storage area for standard parameter settings is faulty.
3	4, 5, 6, 7	Storage area for communication parameter settings is faulty.
4	8 to 9999	Area for manufacturer setting

FR-A800/A800 Plus Series

Instruction Manual Supplement

1 Monitoring terminals S1 and S2 (FR Configurator2)

Graph display using FR Configurator2 is supported for terminals S1 and S2 (data from the high speed sampling and the USB trace file).

The state of terminals S1 and S2 can be displayed in graph form using FR Configurator2.

The FR Configurator2 version 1.28E or later supports graph display for terminals S1 and S2.

For details on FR Configurator2, refer to the FR Configurator2 Instruction Manual.

◆ Digital source (monitor item) selection

- Terminals S1 and S2 can be selected as digital sources for the trace function.
- Select the digital sources (input/output signals) to be set to **Pr.1038 to Pr.1045** from the following table. When a value other than the ones in the following table is set, "0" (OFF) is applied for indication.

Setting value	Signal name
1	STF
2	STR
3	AU
4	RT
5	RL
6	RM
7	RH
8	JOG
9	MRS
10	STP(STOP)
11	RES
12	CS
15	S2
16	S1

Setting value	Signal name
21	X0
22	X1
23	X2
24	X3
25	X4
26	X5
27	X6
28	X7
29	X8
30	X9
31	X10
32	X11
33	X12
34	X13
35	X14
36	X15
37	DY

Setting value	Signal name
101	RUN
102	SU
103	IPF
104	OL
105	FU
106	ABC1
107	ABC2
121	DO0
122	DO1
123	DO2
124	DO3
125	DO4
126	DO5
127	DO6
128	RA1
129	RA2
130	RA3

FR-A800/A800 Plus Series

Instruction Manual Supplement

1 Earth (ground) fault detection at start / restricting reset method for an earth (ground) fault

The reset method for the output side earth (ground) fault overcurrent (E.GF) can be restricted.

- Select whether to enable or disable the earth (ground) fault detection at start. When enabled, the earth (ground) fault detection is performed immediately after a start signal input to the inverter.
- Select whether to restrict the reset method for an earth (ground) fault.

Pr.	Name	Initial value	Setting range	Description	
				Earth (ground) fault	Reset method
249 H101	Earth (ground) fault detection at start	0	0	Not detected at start	Not restricted
			1	Detected at start	
			2		Restricted

◆ Selecting whether to perform the earth (ground) fault detection at start

- If an earth (ground) fault is detected at start while **Pr.249** = "1 or 2", the output side earth (ground) fault overcurrent (E.GF) is detected and output is shut off.
- Earth (ground) fault detection at start is enabled under V/F control and Advanced magnetic flux vector control.
- When the **Pr.72 PWM frequency selection** setting is high, enable the earth (ground) fault detection at start.

NOTE

- Because the detection is performed at start, output is delayed for approx. 20 ms every start.
- Use **Pr.249** to enable/disable the earth (ground) fault detection at start. During operation, earth (ground) faults are detected regardless of the **Pr.249** setting.

◆ Restricting reset method for an earth (ground) fault

- The reset method when the output is shut off due to the output side earth (ground) fault overcurrent (E.GF) can be restricted. When E.GF occurs while **Pr.249** = "2", E.GF can be reset only by turning OFF the control circuit power.
- This restriction prevents the inverter from being damaged due to repeated reset operations by the other methods such as entering the RES signal.
- When E.GF occurs while **Pr.249** = "2", the output short-circuit detection (ALM4) signal can be output.
- For the terminal used to output the ALM4 signal, set "23" (positive logic) or "123" (negative logic) in any of **Pr.190 to Pr.196 (Output terminal function selection)**.
- If **Pr.249** is set to "2" while the retry function is enabled (**Pr.67** is not set to "0"), no retry is performed even when E.GF occurs.
- If **Pr.249** is set to "2" while the automatic bypass switching after inverter fault is enabled (**Pr.138** is not set to "1"), the operation is not switched to the commercial power supply operation even when E.GF occurs.

NOTE

- Changing the terminal assignment using **Pr.190 to Pr.196 (Output terminal function selection)** may affect the other functions. Set parameters after confirming the function of each terminal.
- E.GF is not cleared by turning ON the Fault clear (X51) signal when **Pr.249** = "2".
- If E.GF occurs during emergency drive operation when **Pr.249** = "2", the output is shut off.

2 Output short-circuit fault (E.SCF)

Select the reset operation and fault indication for an output short-circuit.

Pr.	Name	Initial value	Setting range	Description	
				Operation after detection	Reset method
521 H194	Output short-circuit detection	0	0	E.OC1 to E.OC3	Not restricted
			1	E.SCF	Restricted

- The fault indication for an output short-circuit (E.OC1 to E.OC3, and E.SCF) can be changed by the **Pr.521** setting.
- When an output short-circuit is detected while **Pr.521** = "1", E.SCF is displayed and the inverter output is shut off.
- When E.SCF occurs while **Pr.521** = "1", E.SCF can be reset only by turning OFF the control circuit power. (E.OC1 to E.OC3 can be reset by any reset method.)
- This restriction prevents the inverter from being damaged due to repeated reset operations by the other methods such as entering the RES signal.
- When E.SCF occurs, the output short-circuit detection (ALM4) signal can be output.
- For the terminal used to output the ALM4 signal, set "23" (positive logic) or "123" (negative logic) in any of **Pr.190 to Pr.196 (Output terminal function selection)**.
- If the automatic bypass switching after inverter fault is enabled (**Pr.138** is not set to "1"), the operation is not switched to the commercial power supply operation even when E.SCF occurs.

Operation panel indication	E.SCF		FR-LU08 indication	Fault
Name	Output short-circuit fault			
Description	The inverter output is shut off when an output short-circuit is detected while Pr.521 = "1". When Pr.521 = "0" (initial value), E.OC1, E.OC2, or E.OC3 appears when an output short-circuit is detected.			
Check point	Check for output short-circuit.			
Corrective action	Check the wiring to make sure that any output short circuit does not occur, then turn OFF the control circuit power to reset the inverter.			

NOTE

- When short-circuit resistance is large, the current does not reach the short-circuit detection level. In such a case, an output short-circuit cannot be detected.
- Changing the terminal assignment using **Pr.190 to Pr.196 (Output terminal function selection)** may affect the other functions. Set parameters after confirming the function of each terminal.
- E.SCF does not activate the retry function.
- E.SCF is not cleared by turning ON the Fault clear (X51) signal.
- If E.SCF occurs during emergency drive operation, the output is shut off.
- The communication data code for E.SCF is 20 (H14).

3 Extended detection time of the output current and zero current

The setting range of the **Pr.151 Output current detection signal delay time** and **Pr.153 Zero current detection time** is extended.

Pr.	Name	Initial value	Setting range	Description
151 M461	Output current detection signal delay time	0 s	0 to 300 s	Set the output current detection time. Enter the time from when the output current reaches the set current or higher to when the Output current detection (Y12) signal is output.
153 M463	Zero current detection time	0.5 s	0 to 300 s	Set the time from when the output current drops to the Pr.152 setting or lower to when the Zero current detection (Y13) signal is output.

4 Selecting the command interface in the Network operation mode (Pr.338, Pr.339)

- The proximity dog (X76) signal can be input via communication.
- The following table shows the command interface for the function in the Network operation mode, determined by the parameter settings: an external terminal or a communication interface (RS-485 terminals or communication option).

Pr.338 Communication operation command source		0: NET			1: EXT		
Pr.339 Communication speed command source		0: NET	1: EXT	2: EXT	0: NET	1: EXT	2: EXT
X76	Proximity dog	Combined			EXT		

[Explanation of Terms in Table]

EXT: External terminal only

Combined: Either external terminal or communication interface

FR-A800/A800 Plus Series

Instruction Manual Supplement

1 Instructions for UL and cUL

(Standard to comply with: UL 61800-5-1, CSA C22.2 No. 274)

◆ Applicable models

- FR-A842-07700(315K) to 12120(500K)

The above models are compliant with both UL 508C and UL 61800-5-1, CSA C22.2 No. 274.

For the instructions for UL 61800-5-1, CSA C22.2 No. 274, refer to this Instruction Manual Supplement.

For the instructions for UL 508C, refer to the FR-A802 (SEPARATED CONVERTER TYPE) INSTRUCTION MANUAL (HARDWARE)

◆ Product handling information / Informations sur la manipulation du produit

-WARNING- Operation of this product requires detailed installation and operation instructions provided in the Instruction Manual (HARDWARE) and the Instruction Manual (Detailed) intended for use with this product. Please forward relevant manuals to the end user. The manuals can also be downloaded in PDF form from the Mitsubishi Electric FA Global Website. To order manuals, please contact your sales representative.

-AVERTISSEMENT-

L'utilisation de ce produit nécessite des instructions détaillées d'installation et d'utilisation fournies dans les manuels d'instructions en anglais (Instruction Manual (HARDWARE) et Instruction Manual (Detailed)) destinés à être utilisés avec ce produit. Veuillez transmettre les manuels correspondants à l'utilisateur final. Les manuels peuvent également être téléchargés au format PDF sur Mitsubishi Electric FA Global Website. Pour commander des manuels, veuillez contacter votre représentant commercial.

◆ Precautions for compliance with CSA C22.2 No.274

Use the inverter under the conditions of overvoltage category III and pollution degree 2 or lower specified in IEC 60664.

◆ Branch circuit protection

For installation in the United States, branch circuit protection must be provided in accordance with the National Electrical Code and any applicable provincial codes.

For installation in Canada, branch circuit protection must be provided in accordance with the Canadian Electrical Code and any applicable provincial codes. Short circuit protection of the inverter cannot be used as branch circuit protection. Integral solid state short circuit protection does not provide branch circuit protection. Branch circuit protection must be provided in accordance with the National Electrical Code and any additional local code.

■ Precautions for opening the branch-circuit protective device / Précautions pour ouvrir le dispositif de protection du circuit de dérivation

-WARNING- If the fuse melts down or the breaker trips on the input side of this product, check for wiring faults (such as short circuits). Identify and remove the cause of melting down or the trip before replacing the fuse or resetting the tripped breaker (or before applying the power to the inverter again).

-AVERTISSEMENT-

Si le fusible fond ou si le disjoncteur se déclenche du côté entrée de ce produit, vérifier les défauts de câblage (tels que les courts-circuits). Identifier et éliminer la cause de la fonte ou du déclenchement avant de remplacer le fusible ou de réinitialiser le disjoncteur déclenché (ou avant de remettre sous tension l'onduleur).

■ Fuse selection

Fuses are selected based on IEC/EN/UL 61800-5-1 and CSA C22.2 No. 274.

For installation in the United States, the following semi-conductor fuses must be provided, in accordance with the National Electrical Code and any applicable local codes. For installation in Canada, the following semi-conductor fuses must be provided, in accordance with the Canada Electrical Code and any applicable provincial codes. Always install the following semiconductor fuses for branch circuit protection.

- 6-phase rectification

Converter model	Cat. No.	Manufacturer	Rating (A)
FR-CC2-H315K	PC33UD69V1250TF	Mersen	1250
FR-CC2-H355K	PC33UD69V1250TF	Mersen	1250
FR-CC2-H400K	PC33UD69V1400TF	Mersen	1400
FR-CC2-H450K	PC33UD69V1400TF	Mersen	1400
FR-CC2-H500K	PC33UD69V1400TF	Mersen	1400
FR-CC2-H560K	PC33UD69V1400TF	Mersen	1400
FR-CC2-H630K	PC33UD69V1400TF	Mersen	1400

- 12-phase rectification

Converter model	Cat. No.	Manufacturer	Rating (A)
FR-CC2-H315K	PC33UD69V900TF	Mersen	900
FR-CC2-H355K	PC33UD69V900TF	Mersen	900
FR-CC2-H400K	PC33UD69V1100TF	Mersen	1100
FR-CC2-H450K	PC33UD69V1100TF	Mersen	1100
FR-CC2-H500K	PC33UD69V1100TF	Mersen	1100
FR-CC2-H560K	PC33UD69V1100TF	Mersen	1100
FR-CC2-H630K	PC33UD69V1100TF	Mersen	1100

◆ Capacitor discharge time / Temps de décharge du condensateur

CAUTION -Risk of Electric Shock-

Before wiring or inspection, check that the LED indicator turns OFF. Any person who is involved in wiring or inspection shall wait for 10 minutes or longer after power OFF and check that there are no residual voltage using a digital multimeter or the like. The capacitor is charged with high voltage for some time after power OFF, and it is dangerous.

ATTENTION -Risque de choc électrique-

Avant le câblage ou l'inspection, vérifier que le témoin LED s'éteint. Toute personne impliquée dans le câblage ou l'inspection doit attendre 10 minutes ou plus après la mise hors tension et vérifier l'absence de tension résiduelle à l'aide d'un multimètre numérique ou similaire. Le condensateur est chargé avec une haute tension pendant un certain temps après la mise hors tension, ce qui est dangereux. Précautions pour ouvrir le dispositif de protection du circuit de dérivation.

◆ Wiring to the power supply and the motor

- Refer to the National Electrical Code (Article 310) regarding the allowable current of the cable. Select the cable size for 125% of the rated current according to the National Electrical Code (Article 430). For wiring the input (R/L1, S/L2, T/L3) and output (U, V, W) terminals of the inverter, use the UL listed copper, stranded wires (rated at 75°C) and round crimp terminals. Crimp the terminals with the crimping tool recommended by the terminal manufacturer.

◆ Short circuit ratings

- Suitable for use in a circuit capable of delivering not more than 100 kA rms symmetrical amperes, 500 V Maximum.

◆ Motor overload protection

When using the electronic thermal relay function as motor overload protection, set the rated motor current in **Pr.9**
Electronic thermal O/L relay.

Operation characteristics of electronic thermal relay function

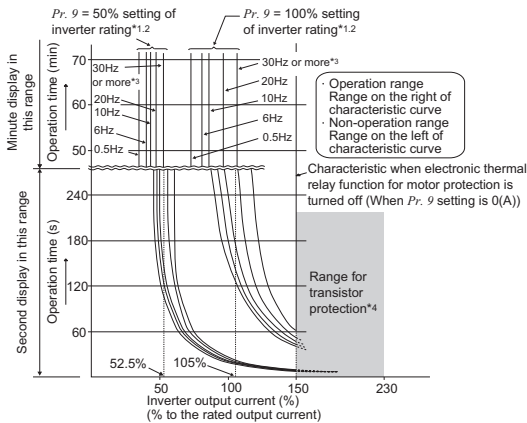

This function detects the overload (overheat) of the motor, stops the operation of the inverter's output transistor, and stops the output. (The operation characteristic is shown on the left.)

- When using the Mitsubishi Electric constant-torque motor
 - (1) Set one of "1, 13 to 16" in **Pr.71**. (This provides a 100% continuous torque characteristic in the low-speed range.)
 - (2) Set the rated current of the motor in **Pr.9**.

- *1 When a value 50% of the inverter rated output current (current value) is set in **Pr.9**
- *2 The % value denotes the percentage to the inverter rated current. It is not the percentage to the rated motor current.
- *3 When you set the electronic thermal relay function dedicated to the Mitsubishi Electric constant-torque motor, this characteristic curve applies to operation at 6 Hz or higher.
- *4 Transistor protection is activated depending on the temperature of the heat sink. The protection may be activated even with less than 150% depending on the operating conditions.

NOTE

- The internal accumulated heat value of the electronic thermal relay function is reset by inverter power reset and reset signal input. Avoid unnecessary reset and power-OFF.
- When multiple motors are driven with a single inverter or when a multi-pole motor or a special motor is driven, install an external thermal relay (OCR) between the inverter and motors. Note that the current indicated on the motor rating plate is affected by the line-to-line leakage current (details in the Instruction Manual (HARDWARE)) when selecting the setting for an external thermal relay.
- The cooling effect of the motor drops during low-speed operation. Use a thermal protector or a motor with built-in thermistor.
- When the difference between the inverter and motor capacities is large and the setting is small, the protective characteristics of the electronic thermal relay function will be deteriorated. In this case, use an external thermal relay.
- A special motor cannot be protected by the electronic thermal relay function. Use an external thermal relay.
- Motor over temperature sensing is not provided by the drive.

◆ Applicable power supply

For use at an altitude above 2000 m (maximum 2500 m), only a neutral-point earthed (grounded) power supply can be used.

MEMO

mitsubishi electric corporation
HEAD OFFICE: TOKYO BUILDING 2-7-3, MARUNOUCHI, CHIYODA-KU, TOKYO 100-8310, JAPAN