



Safety Guidelines

NZ2GFSS2-32D
NZ2GFSS2-8D
NZ2GFSS2-8TE
NZ2GFSS2-16DTE
NZ2EXSS2-8TE

Thank you for purchasing the programmable controller.
Prior to use, please read this and relevant manuals thoroughly to fully understand the product.

'TRANSLATION OF THE ORIGINAL INSTRUCTIONS'

MODEL	CCIEF-SFIO-U-HW
MODEL CODE	13J299
IB(NA)-0800542-I(2308)MEE	

SAFETY PRECAUTIONS

(Read these precautions before using this product.)

Before using this product, please read this manual and the relevant manuals carefully and pay full attention to safety to handle the product correctly.

In this manual, the safety precautions are classified into two levels: "⚠ WARNING" and "⚠ CAUTION".



WARNING

Indicates that incorrect handling may cause hazardous conditions, resulting in death or severe injury.



CAUTION

Indicates that incorrect handling may cause hazardous conditions, resulting in minor or moderate injury or property damage.

Under some circumstances, failure to observe the precautions given under "⚠ CAUTION" may lead to serious consequences.

Observe the precautions of both levels because they are important for personal and system safety.

Make sure that the end users read this manual and then keep the manual in a safe place for future reference.

[Design Precautions]



WARNING

- When the safety remote I/O module detects an error in an external power supply or a failure in the module, it turns off the outputs. Create an external circuit to securely stop the power of hazard by turning off the outputs of the safety remote I/O module. Incorrect configuration of the circuit may result in an accident due to an incorrect output or malfunction.
 - When a load current exceeding the rated current or an overcurrent caused by a load short-circuit flows in the safety remote I/O module, the module defines it as a fault and turns off the outputs. However, if overcurrent flows for a long time, it may cause smoke and fire. To prevent this, configure an external safety circuit, such as a fuse.
 - At the start-up of the system, if a short-circuit has occurred at the output wiring of the external power supply, a load may turn on just after the power-on. Configure an interlock circuit to ensure that the entire system will always operate safely.
 - When a communication failure occurs in the network, the failed station becomes the following status.
 - (1) All inputs from remote I/O station turn off.
 - (2) All outputs from remote I/O station turn off.Check the communication status information and configure an interlock circuit in the program to ensure that the entire system will operate safely. Failure to do so may result in an accident due to an incorrect output or malfunction.
 - Do not read or write any data from/to the "use prohibited" areas in the remote register. If data is read or written, correct operation of the module cannot be guaranteed.
-

[Design Precautions]

CAUTION

- Do not install the control lines or communication cables together with the main circuit lines or power cables. Keep a distance of 100mm or more between them. Failure to do so may result in malfunction due to noise.
- Select the external devices to be connected to the module by referring to the performance specifications in this manual and considering the maximum inrush current. Exceeding the maximum inrush current may cause malfunction or failure of the module.

[Security Precautions]

WARNING

- To maintain the security (confidentiality, integrity, and availability) of the programmable controller and the system against unauthorized access, denial-of-service (DoS) attacks, computer viruses, and other cyberattacks from external devices via the network, take appropriate measures such as firewalls, virtual private networks (VPNs), and antivirus solutions.

[Installation Precautions]

WARNING

- Shut off the external power supply (all phases) used in the system before mounting or removing the module. Failure to do so may result in electric shock or cause the module to fail or malfunction.

[Installation Precautions]

CAUTION

- Use the module in an environment that meets the general specifications in the user's manual. Failure to do so may result in electric shock, fire, malfunction, or damage to or deterioration of the product.
- Do not directly touch any conductive parts and electronic components of the module. Doing so can cause malfunction or failure of the module.
- After the first use of the product, do not connect/remove the extension module more than 50 times (IEC 61131-2 compliant). Exceeding the limit may cause malfunction.
- To connect an extension module to a main module, engage the respective connectors and securely lock the module joint levers. Incorrect interconnection may cause malfunction, failure, or drop of the module.
- After the first use of the product, do not connect/remove the connector more than 50 times (IEC 61131-2 compliant). Exceeding the limit may cause malfunction.
- Connect each connection cable to the connector securely. Poor contact may cause malfunction.

[Wiring Precautions]

WARNING

- Shut off the external power supply (all phases) used in the system before installation and wiring. Failure to do so may result in electric shock or cause the module to fail or malfunction.

[Wiring Precautions]

CAUTION

- Individually ground the FG terminal of the programmable controller with a ground resistance of 100 ohms or less. Failure to do so may result in electric shock or malfunction.
- Check the rated voltage and terminal layout before wiring to the module, and connect the cables correctly. Connecting a power supply with a different voltage rating or incorrect wiring may cause fire or failure.
- Tighten the terminal block mounting screw within the specified torque range. Undertightening can cause short circuit, fire, or malfunction. Overtightening can damage the screw and/or module, resulting in drop, short circuit, or malfunction.
- Prevent foreign matter such as dust or wire chips from entering the module. Such foreign matter can cause a fire, failure, or malfunction.
- A protective film is attached to the top of the module to prevent foreign matter, such as wire chips, from entering the module during wiring. Do not remove the film during wiring. Remove it for heat dissipation before system operation.
- Place the cables in a duct or clamp them. If not, dangling cable may swing or inadvertently be pulled, resulting in damage to the module or cables or malfunction due to poor contact.
- When disconnecting the cable from the module, do not pull the cable by the cable part. For the cable with connector, hold the connector part of the cable. For the cable connected to the terminal block, loosen the terminal block screw. Pulling the cable connected to the module may result in malfunction or damage to the module or cable.
- Do not install the control lines or communication cables together with the main circuit lines or power cables. Keep a distance of 100mm or more between them. Failure to do so may result in malfunction due to noise.
- When an overcurrent caused by an error of an external device or a failure of the module flows for a long time, it may cause smoke and fire. To prevent this, configure an external safety circuit, such as a fuse.

[Startup and Maintenance Precautions]

WARNING

- Do not touch any terminal while power is on. Doing so will cause electric shock or malfunction.
- Shut off the external power supply (all phases) used in the system before cleaning the module or retightening the terminal block mounting screw. Failure to do so may result in electric shock. Tighten the terminal block mounting screw within the specified torque range. Undertightening can cause short circuit, fire, or malfunction. Overtightening can damage the screw and/or module, resulting in drop, short circuit, or malfunction.

[Startup and Maintenance Precautions]

CAUTION

- Do not disassemble or modify the modules. Doing so may cause failure, malfunction, injury, or a fire.
- Use any radio communication device such as a cellular phone or PHS (Personal Handy-phone System) 25cm or more away in all directions from the module. Failure to do so may cause malfunction.
- Shut off the external power supply (all phases) used in the system before mounting or removing the module. Failure to do so may cause the module to fail or malfunction.
- Before handling the module, touch a conducting object such as a grounded metal to discharge the static electricity from the human body. Failure to do so may cause the module to fail or malfunction.
- Do not drop or apply strong shock to the module. Doing so may damage the module.
- Shut off the external power supply (all phases) used in the system before installing or removing a module in/from the control panel. Failure to do so may cause the module to fail or malfunction.
- Check the module once a day, by turning on output signals and confirming that no error occurs.

[Disposal Precautions]

CAUTION

- When disposing of this product, treat it as industrial waste.

[Transportation Precautions]

CAUTION

- When transporting lithium batteries, follow the transportation regulations. For details on the regulated models, refer to the MELSEC iQ-R Module Configuration Manual.
- The halogens (such as fluorine, chlorine, bromine, and iodine), which are contained in a fumigant used for disinfection and pest control of wood packaging materials, may cause failure of the product. Prevent the entry of fumigant residues into the product or consider other methods (such as heat treatment) instead of fumigation. The disinfection and pest control measures must be applied to unprocessed raw wood.

[Precautions for Using Products]

WARNING

- Although MELCO has obtained the certification for Product's compliance to the international safety standards IEC 61508 and ISO 13849-1 from TUV Rheinland, this fact does not guarantee that Product will be free from any malfunction or failure.
- With very small probability shown in PFDavg / PFH, the safety remote I/O module has residual risk that input and output may remain on or off. When using this product, perform risk assessment on target equipment, and select appropriate SIL and PL, as well as reduce the risk.

PRÉCAUTIONS DE SÉCURITÉ

(Lire ces précautions avant toute utilisation du produit.)

Avant d'utiliser ce produit, lire attentivement ce manuel ainsi que les manuels auxquels il renvoie, et toujours considérer la sécurité comme de la plus haute importance en manipulant le produit correctement.

Dans ce manuel, les précautions de sécurité sont classées en deux niveaux, à savoir : "⚠️ AVERTISSEMENT" and "⚠️ ATTENTION".



AVERTISSEMENT

Attire l'attention sur le fait qu'une négligence peut créer une situation de danger avec risque de mort ou de blessures graves.



ATTENTION

Attire l'attention sur le fait qu'une négligence peut créer une situation de danger avec risque de blessures légères ou de gravité moyennes ou risque de dégâts matériels.

Dans certaines circonstances, le non-respect d'une précaution de sécurité introduite sous le titre "ATTENTION" peut avoir des conséquences graves.

Les précautions de ces deux niveaux doivent être observées dans leur intégralité car elles ont trait à la sécurité des personnes et aussi du système.

Veiller à ce que les utilisateurs finaux lisent ce manuel qui doit être conservé soigneusement à portée de main pour s'y référer autant que de besoin.

[Précautions lors de la conception]



AVERTISSEMENT

- *Quand un module E/S distant de sécurité détecte une erreur dans une alimentation externe, il désactive les sorties. Pour se prémunir contre les risques d'alimentation, créer un circuit externe désactivant les sorties du module E/S distant de sécurité. Une configuration incorrecte de ce circuit peut être à l'origine d'un accident par suite des sorties erronées ou de dysfonctionnements.*
 - *Si un courant de charge excédant le courant nominal circule dans le module E/S distant de sécurité ou en cas de surintensité suite à une court-circuit à la charge, le module détecte l'anomalie et désactive les sorties. Si l'intensité excessive du courant dure longtemps, il peut y avoir dégagement de fumée et feu. Pour éviter cela, prévoir un circuit de sécurité externe, avec par exemple un fusible.*
 - *Lors du démarrage du système, s'il survient un court-circuit dans le câblage de sortie de l'alimentation externe, il peut y avoir application d'une charge dès la mise sous tension. Configurer un circuit d'interverrouillage permettant de garantir la sécurité de fonctionnement de l'ensemble du système en tous temps.*
 - *À la survenance d'une panne de communication dans le réseau, la station défaillante se trouve dans l'état suivant :*
 - (1) Toutes les entrées en provenance de la station E/S distante sont désactivées.*
 - (2) Toutes les sorties de la station E/S distante sont désactivées.*

Sur la base des infos d'état de communication, configurer dans le programme un circuit d'interverrouillage pour garantir la sécurité de fonctionnement de l'ensemble du système. Faute de quoi, il y a risque d'accident par suite de sortie erronée ou de dysfonctionnement.
-

[Précautions lors de la conception]

AVERTISSEMENT

- *Ne lisez ni n'inscrivez aucune donnée depuis/dans les zones du registre distant marquées "use prohibited". Si les données sont lues ou inscrites, le bon fonctionnement du module ne peut être garanti.*

[Précautions lors de la conception]

ATTENTION

- *Ne pas installer les lignes de commande ou câbles de communication avec les lignes des circuits principaux ou câbles d'alimentation. Maintenir entre eux une distance de 100mm au minimum. Faute de quoi, il y a risque de dysfonctionnement ou de bruit.*
- *Choisir les appareils externes à raccorder au module en se reportant aux indications de performances dans ce manuel et en tenant compte du courant d'appel maximum. Le raccordement d'un appareil avec un courant d'appel excédant le maximum admissible peut être à l'origine de pannes ou de dysfonctionnements du module.*

[Précautions de sécurité]

AVERTISSEMENT

- *Pour maintenir la sécurité (confidentialité, intégrité et disponibilité) de l'automate programmable et du système contre les accès non autorisés, les attaques par déni de service (DoS), les virus informatiques et autres cyberattaques d'appareils externes via le réseau, prendre les mesures appropriées telles que la configuration d'un pare-feu ou d'un réseau privé virtuel (VPN), ou l'installation d'un logiciel antivirus sur l'ordinateur.*

[Précautions d'installation]

AVERTISSEMENT

- *Couper l'alimentation externe utilisée par le système (sur toutes les phases) avant la mise en place ou le retrait du module. Faute de quoi, il y a risque de choc électrique et de dysfonctionnement ou panne du module.*

[Précautions d'installation]

ATTENTION

- *Utiliser le module dans un environnement conforme aux spécifications générales du manuel de l'utilisateur. Faute de quoi, il y a risque de choc électrique, de feu, de dysfonctionnement ou d'endommagement et de détérioration du produit.*
 - *Ne pas toucher directement les parties conductrices ou composants électroniques du module. Ceci pourrait être à l'origine de dysfonctionnement ou panne du module.*
 - *Après la première mise en service du produit, le nombre maximum admissible d'opérations de connexion/déconnexion du module d'extension est de 50 (selon IEC 61131-2). Au-delà de cette limite, il y a risque de dysfonctionnements.*
 - *Pour raccorder un module d'extension au module principal, enficher les connecteurs respectifs et engager les loquets de module jusqu'à encliquètement. Une mauvaise interconnexion peut être à l'origine de dysfonctionnements ou pannes et de chute du module.*
 - *Après la première mise en service du produit, le nombre maximum admissible d'opérations de connexion/déconnexion du connecteur est de 50 (selon IEC 61131-2). Au-delà de cette limite, il y a risque de dysfonctionnements.*
 - *Raccorder fermement les connecteurs des câbles. Tout mauvais contact peut être source de dysfonctionnements.*
-

[Précautions de câblage]

AVERTISSEMENT

- *Couper l'alimentation externe utilisée par le système (sur toutes les phases) avant l'installation et le câblage. Faute de quoi, il y a risque de choc électrique et de dysfonctionnement ou panne du module.*
-

[Précautions de câblage]

! ATTENTION

- *Mettre séparément à la terre la borne FG de l'automate programmable avec une résistance de terre de moins de 100 ohms. Faute de quoi, il y a risque de choc électrique ou de dysfonctionnement.*
- *Vérifier la tension nominale et l'affectation des bornes avant le câblage du module, et raccorder les câbles correctement. Tout raccordement de câble d'alimentation de tension incorrecte ou toute erreur de câblage peut être à l'origine d'un feu ou d'une panne.*
- *Serrer les vis de fixation du borniers dans les limites du couple de serrage prescrit. Un serrage insuffisant peut être à l'origine d'un court-circuit, feu ou dysfonctionnement. Un serrage excessif peut endommager la vis et/ou le module avec risque de chute, court-circuit ou dysfonctionnement.*
- *Veiller à ne pas laisser la poussière, les copeaux métalliques ou d'autres corps étrangers pénétrer dans le module. De telles corps étrangers peuvent être à l'origine d'un départ de feu, d'une panne ou d'un dysfonctionnement.*
- *Le haut du module est recouvert d'un film protecteur pour éviter toute pénétration de corps étrangers comme des copeaux métalliques pendant le câblage du module. Ne pas retirer le film protecteur avant de terminer le câblage. Il doit cependant être retiré avant la mise en service du système pour une meilleure dispersion de la chaleur.*
- *Les câbles doivent être placés dans un conduit ou doivent être attachés. Faute de quoi, un ballotement de câble ou une traction sur un câble peut endommager le module ou les câbles ou entraîner des dysfonctionnements par mauvais contact.*
- *Pour débrancher un câble du module, ne jamais tirer sur le câble proprement dit. Pour un câble à connecteur, saisir le câble par son connecteur. Pour un câble raccordé au bornier, commencer par desserrer la vis de borne. Tout effort de traction sur un câble raccordé au module peut être à l'origine de dysfonctionnements ou peut endommager le module ou le câble.*
- *Ne pas installer les lignes de commande ou câbles de communication avec les lignes des circuits principaux ou câbles d'alimentation. Maintenir entre eux une distance de 100mm au minimum. Faute de quoi, il y a risque de dysfonctionnement ou de bruit.*
- *Si une surintensité produite par une erreur dans un dispositif externe ou suite à une panne du module circule pendant longtemps, il y a risque de dégagement de fumée et de feu. Pour éviter cela, prévoir un circuit de sécurité externe, avec par exemple un fusible.*

[Précautions de mise en service et de maintenance]

! AVERTISSEMENT

- *Ne toucher à aucune borne quand l'appareil est sous tension. Il y a risque de choc électrique ou de dysfonctionnement.*
 - *Couper l'alimentation externe utilisée par le système (sur toutes les phases) avant de nettoyer le module ou de resserrer les vis de fixation du bornier. Faute de quoi, il y a risque de choc électrique. Serrer les vis de fixation du borniers dans les limites du couple de serrage prescrit. Un serrage insuffisant peut être à l'origine d'un court-circuit, feu ou dysfonctionnement. Un serrage excessif peut endommager la vis et/ou le module avec risque de chute, court-circuit ou dysfonctionnement.*
-

[Précautions de mise en service et de maintenance]

ATTENTION

- *Ne pas démonter ou modifier le module. Cela créerait un risque de panne, dysfonctionnement, blessure ou départ de feu.*
- *Tout type d'appareil de communication radio, comme les téléphones portables ou les appareils PHS (Personal handy-phone system), doit être tenu éloigné de 25 cm ou plus du module, dans tous les sens. Le non-respect de cette précaution expose à des dysfonctionnements.*
- *Couper l'alimentation externe utilisée par le système (sur toutes les phases) avant la mise en place ou le retrait du module. Faute de quoi, il y a risque de dysfonctionnement ou panne du module.*
- *Avant de toucher le module, éliminer l'électricité statique dont le corps humain est porteur en touchant un objet métallique relié à la terre. Faute de quoi, il y a risque de panne ou de dysfonctionnement du module.*
- *Ne pas faire tomber ou exposer le module à des chocs. Cela pourrait endommager le module.*
- *Couper l'alimentation externe utilisée par le système (sur toutes les phases) avant la mise en place ou le retrait du module dans l'armoire de commande. Faute de quoi, il y a risque de dysfonctionnement ou panne du module.*
- *Vérifier le module une fois par jour, en activant les signaux de sortie pour vérifier qu'aucune erreur ne survient.*

[Précautions de mise au rebut]

ATTENTION

- *Lors de sa mise au rebut, ce produit doit être traité comme un déchet industriel.*

[Précautions de transport]

ATTENTION

- *Pour le transport des piles au lithium, respecter la réglementation afférente à ce transport. Pour le détail des modèles soumis à une réglementation, voir le MELSEC iQ-R Module Configuration Manual (Manuel de configuration du module MELSEC iQ-R).*
- *Les halogènes (comme le fluore, le chlore, le brome ou l'iode) contenus dans certains fumigènes de désinfection et de traitement antiparasite des emballage en bois peuvent endommager le produit. Protéger le produit contre la pénétration des résidus de fumigènes ou envisager d'autres méthodes de traitement que la fumigation (traitement thermique par exemple). Une désinfection et un traitement antiparasite doivent être appliqués sur le bois brut avant façonnage.*

 **AVERTISSEMENT**

- Bien que MELCO ait obtenu la certification que le Produit est conforme aux normes de sécurité internationales CEI 61508 et ISO 13849-1 de la part de TUV Rheinland, ceci ne garantit pas que le Produit sera exempt de défaut ou de panne.
 - Avec une très faible probabilité indiquée dans PFDavg/PFH, le module E/S de sécurité à distance présente un risque résiduel que l'entrée et la sortie puissent rester activées ou désactivées. Lors de l'utilisation de ce produit, effectuez une évaluation des risques sur l'équipement cible et sélectionnez les SIL et PL appropriés et veillez aussi à réduire les risques
-

CONDITIONS OF USE FOR THE PRODUCT

- (1) Although Mitsubishi Electric has obtained the certification for Product's compliance to the international safety standards IEC61508, ISO13849-1 from TUV Rheinland, this fact does not guarantee that Product will be free from any malfunction or failure. The user of this Product shall comply with any and all applicable safety standard, regulation or law and take appropriate safety measures for the system in which the Product is installed or used and shall take the second or third safety measures other than the Product. Mitsubishi Electric is not liable for damages that could have been prevented by compliance with any applicable safety standard, regulation or law.
- (2) Mitsubishi Electric prohibits the use of Products with or in any application involving, and Mitsubishi Electric shall not be liable for a default, a liability for defect warranty, a quality assurance, negligence or other tort and a product liability in these applications.
 - (a) power plants,
 - (b) trains, railway systems, airplanes, airline operations, other transportation systems,
 - (c) hospitals, medical care, dialysis and life support facilities or equipment,
 - (d) amusement equipments,
 - (e) incineration and fuel devices,
 - (f) handling of nuclear or hazardous materials or chemicals,
 - (g) mining and drilling,
 - (h) and other applications where the level of risk to human life, health or property are elevated.
- (3) Mitsubishi Electric shall have no responsibility or liability for any problems involving programmable controller trouble and system trouble caused by DoS attacks, unauthorized access, computer viruses, and other cyberattacks.

CONTENTS

SAFETY PRECAUTIONS	1
CONDITIONS OF USE FOR THE PRODUCT	11
1 RELEVANT MANUALS	13
2 PACKING LIST	14
3 SPECIFICATIONS	15
3.1 Operating Ambient Temperature	15
3.2 Safety Standards	15
4 INSTALLATION ENVIRONMENT AND INSTALLATION POSITION	16
4.1 Installation Environment	16
4.2 Installation Position	17
4.3 Installation Direction	18
5 WIRING	19
5.1 Wiring Products	19
5.2 Precautions for wiring the safety remote I/O module to safety devices	22
5.3 Examples of Wiring to Safety Devices	24
6 MODULE STATUS AFTER POWER-ON AND LED STATUS	35
7 EMC, LOW VOLTAGE, AND MACHINERY DIRECTIVES	36
7.1 Measures to Comply with the EMC Directive	36
7.2 Requirements for Low Voltage Directive Compliance	42
7.3 Requirements to Comply with the Machinery Directive	43
8 PRECAUTIONS FOR USING A SAFETY PROGRAMMABLE CONTROLLER	44
9 Declaration of Conformity	47
9.1 EU DECLARATION OF CONFORMITY	47
9.2 UK DECLARATION OF CONFORMITY	49
REVISIONS	51
WARRANTY	52

1 RELEVANT MANUALS

The details on this product are described in the following manual, which is sold separately. Please develop familiarity with the functions and performance of the product to handle it correctly.

The following are translated from the original Japanese version. For the Japanese version, please consult your local Mitsubishi representative.

- CC-Link IE Field Network Remote I/O Module (With Safety Functions) User's Manual
SH-081449ENG(13JX44)
- MELSEC iQ-R Safety Application Guide
SH-081538ENG

2 PACKING LIST

Check that the following items are included in the package.

Item	Quantity
Module	1
This manual	1

3 SPECIFICATIONS

3.1 Operating Ambient Temperature

Température ambiante de fonctionnement

Use this product under the temperature of 0 to 55°C.

Utiliser ce produit avec une température ambiante entre 0 et 55°C.

3.2 Safety Standards

Normes de sécurité

Observe the following safety standards.

Region	Standard
Global	IEC61508, IEC62061, ISO13849 IEC61131-2 IEC61000-6-2, IEC61000-6-4 IEC61784-3 IEC60204-1
Europe	EN ISO13849-1 EN61131-2 EN61000-6-2, EN61000-6-4
North America	UL508 (NZ2GFSS2-32D) UL61010-1, UL61010-2-201 (NZ2GFSS2-8D, NZ2GFSS2-8TE, or NZ2GFSS2-16DTE)

Observer les normes de sécurité suivantes.

Région	Norme
Global	IEC61508, IEC62061, ISO13849 IEC61131-2 IEC61000-6-2, IEC61000-6-4 IEC61784-3 IEC60204-1
Europe	EN ISO13849-1 EN61131-2 EN61000-6-2, EN61000-6-4
Amérique du Nord	UL508 (NZ2GFSS2-32D) UL61010-1, UL61010-2-201 (NZ2GFSS2-8D, NZ2GFSS2-8TE, ou NZ2GFSS2-16DTE)

4 INSTALLATION ENVIRONMENT AND INSTALLATION POSITION

4.1 Installation Environment

Installation location

Do not install the safety remote I/O module to the place where:

- Ambient temperature is outside the range of 0 to 55°C;
- Ambient humidity is outside the range of 5 to 95%RH;
- Condensation occurs due to rapid temperature change;
- Corrosive gas or combustible gas is present;
- Conductive powder such as dust and iron powder, oil mist, salinity, or organic solvent is filled;
- The safety remote I/O module is exposed to direct sunlight;
- A strong electric field or strong magnetic field is generated; and
- The safety remote I/O module is subject to vibration and shock.

Installation surface

Install the safety remote I/O module on the flat surface. When the installation surface is uneven, excessive force is applied to the printed-circuit board, causing a defect.

4.2 Installation Position

When installing the safety remote I/O module in a control panel, provide clearance of 60mm or longer between the module and the sides of the control panel or neighboring modules to ensure good ventilation and an easy module change.

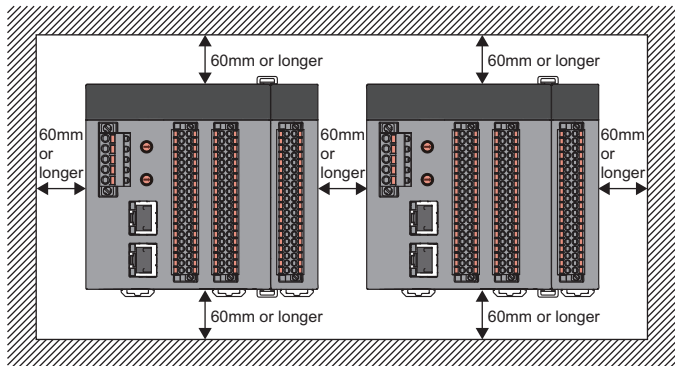

The figure above shows the examples for the NZ2GFSS2-32D and NZ2EXSS2-8TE.

4.3 Installation Direction

The safety remote I/O module can be installed in six directions. Use the DIN rail to install the module.

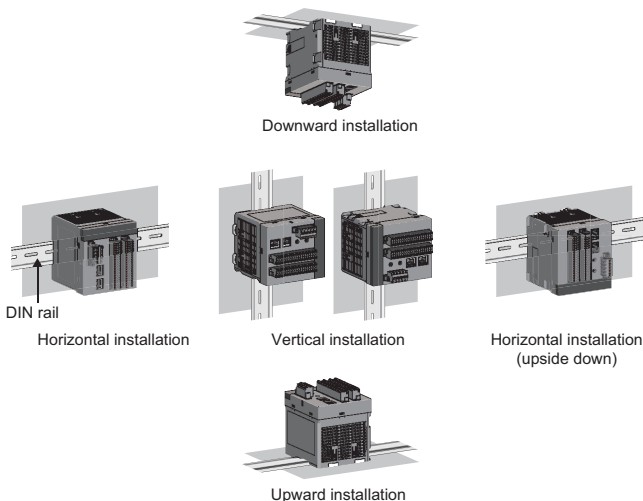

The figure above shows the examples for the NZ2GFSS2-32D and NZ2EXSS2-8TE.

Point

When the safety remote I/O module is installed in the direction other than the horizontal installation, the max. number of simultaneous input points and the maximum load current is restricted. For the restriction, refer to the following.

 CC-Link IE Field Network Remote I/O Module (With Safety Functions) User's Manual

5 WIRING

5 Câblage

5.1 Wiring Products

Produits pour câblage

CC-Link IE Field Network



The following table shows applicable cables to connect to the CC-Link IE Field Network port. Use the cables that meet the standards of IEEE 802.3 1000BASE-T.

Name	Connector	Cable	Category
1000BASE-T	RJ45	Straight cable (Double shielded/STP)	5e or higher

Réseau de terrain CC-Link IE



Le tableau ci-dessous indique quels câbles peuvent être utilisés pour le raccordement au port du réseau de terrain CC-Link IE. Utiliser des câbles conformes aux normes IEEE 802.3 1000BASE-T.

Nom	Connecteur	Câble	Catégorie
1000BASE-T	RJ45	Câble simple (Double blindé/STP)	5e ou plus

Wiring to an I/O terminal block

The table below shows applicable bar solderless terminals connected to the terminal block. When wiring, use applicable wires and an appropriate tightening torque. Use UL listed bar solderless terminals and, for processing, use a tool recommended by their manufacturer.

Bar solderless terminal	Wire			
	Diameter	Type	Material	Temperature rating
A10.34-10TQ A10.5-10WH A10.75-10GY A1.0-10 A1.5-10	22 to 16 AWG	Stranded	Copper	75°C or more

Câblage à un bornier E/S.

La table ci-dessous indique quels types de barrette de bornes sans soudure peuvent être raccordés au bornier. Pour le câblage, utiliser les fils appropriés. Utiliser des barrettes de bornes sans soudure répertoriées par UL et, pour la mise en place, utiliser l'outil recommandé par leur fabricant.

Borne-barre sans soudure	Fil			
Modèle	Diamètre	Type	Matériau	Gamme de température
AI0.34-10TQ AI0.5-10WH AI0.75-10GY AI1.0-10 AI1.5-10	22 à 16 AWG	Torsadé	Cuivre	75°C ou plus

Wiring to a module power supply

The table below shows applicable bar solderless terminals connected to the terminal block. When wiring, use applicable wires and an appropriate tightening torque. Use UL listed bar solderless terminals and, for processing, use a tool recommended by their manufacturer.

■ Main module (NZ2GFSS2-32D)

Bar solderless terminal	Wire			
Model	Diameter	Type	Material	Temperature rating
AI0.5-10WH AI0.75-10GY AI1-10RD AI1.5-10BK AI2.5-10BU	20 to 14 AWG	Stranded	Copper	75°C or more

■ Main module (NZ2GFSS2-8D, NZ2GFSS2-8TE, or NZ2GFSS2-16DTE)

Bar solderless terminal	Wire			
Model	Diameter	Type	Material	Temperature rating
AI0.34-8 AI0.5-8WH AI0.75-8GY AI1-8RD AI1.5-8BK	22 to 16 AWG	Stranded	Copper	75°C or more

Câblage à une alimentation de module

La table ci-dessous indique quels types de barrette de bornes sans soudure peuvent être raccordés au bornier. Pour le câblage, utiliser les fils appropriés. Utiliser des barrettes de bornes sans soudure répertoriées par UL et, pour la mise en place, utiliser l'outil recommandé par leur fabricant.

■ Module principal (NZ2GFSS2-32D)

Borne-barre sans soudure	Fil			
Modèle	Diamètre	Type	Matériau	Gamme de température
A10.5-10WH A10.75-10GY A11-10RD A11.5-10BK A12.5-10BU	20 à 14 AWG	Torsadé	Cuivre	75°C ou plus

■ Module principal (NZ2GFSS2-8D, NZ2GFSS2-8TE, ou NZ2GFSS2-16DTE)

Borne-barre sans soudure	Fil			
Modèle	Diamètre	Type	Matériau	Gamme de température
A10.34-8 A10.5-8WH A10.75-8GY A11-8RD A11.8BK	22 à 16 AWG	Torsadé	Cuivre	75°C ou plus

5.2 Precautions for wiring the safety remote I/O module to safety devices

This section describes the precautions for the wiring.

To wire the safety remote I/O module to each safety device according to Category 4, perform both of the following for the safety remote I/O module.

- Double wiring inputs/outputs
- Executing the self-diagnostics function (dark test)

When performing the operations above, observe the precautions below.

When wiring the input part

■ Combination of input terminals

The following table lists the applicable combinations of input terminals.

If the combinations other than the below are used, a minor error occurs.

Combination of input terminals*1

X0, X1	X2, X3	X4, X5	X6, X7	X8, X9	XA, XB	XC, XD	XE, XF
X10, X11	X12, X13	X14, X15	X16, X17	X18, X19	X1A, X1B	X1C, X1D	X1E, X1F

*1 For the NZ2GFSS2-8D, NZ2GFSS2-8TE, or NZ2GFSS2-16DTE, X0 to X7 can be used for input terminals.

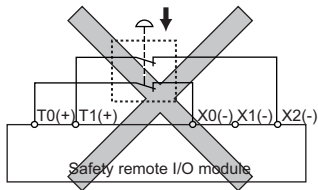
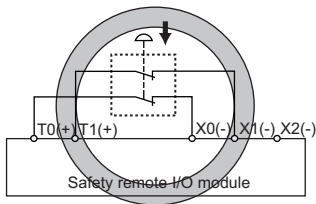

■ Test pulse output terminal combination

The same test pulse cannot be used for the combinations for one device.

If the combinations of the same test pulse are used for one device (X0 and T0, X1 and T0 for instance), a minor error occurs.

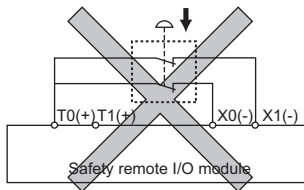
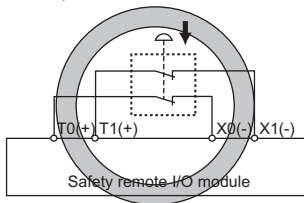

When wiring the output part

■ Combination of output terminals

The following table lists the applicable combinations of output terminals.

If the combinations other than the below are used, a minor error occurs.

Combination of output terminals

Y0, Y1	Y2, Y3	Y4, Y5	Y6, Y7
--------	--------	--------	--------

Wiring of the external power supply

If the external power supply is off while the module power supply is on, a moderate error (external power supply voltage error) occurs. Power on the external power supply at the same timing of power-on of the module power supply.

5.3 Examples of Wiring to Safety Devices

Exemples de câblage à des dispositifs de sécurité

This section describes wiring of the safety remote I/O module to safety devices.

For how to wire the module to specific safety devices, refer to the following.

📖 MELSEC iQ-R Safety Application Guide

Cette section décrit le câblage du module E/S distant de sécurité vers les dispositifs de sécurité.

Pour la méthode de câblage entre le module et chacun des dispositifs de sécurité particuliers, voir ce qui suit.

📖 *Guide des application de sécurité MELSEC iQ-R*

Wiring example of the NZ2GFSS2-32D

Exemple de câblage du NZ2GFSS2-32D

■ Example of wiring to a switch with NC/NC contact and to a safety sensor

■ Exemple de câblage à un commutateur à contact NC/NC et à un capteur de sécurité.

Terminal block for module power supply and FG

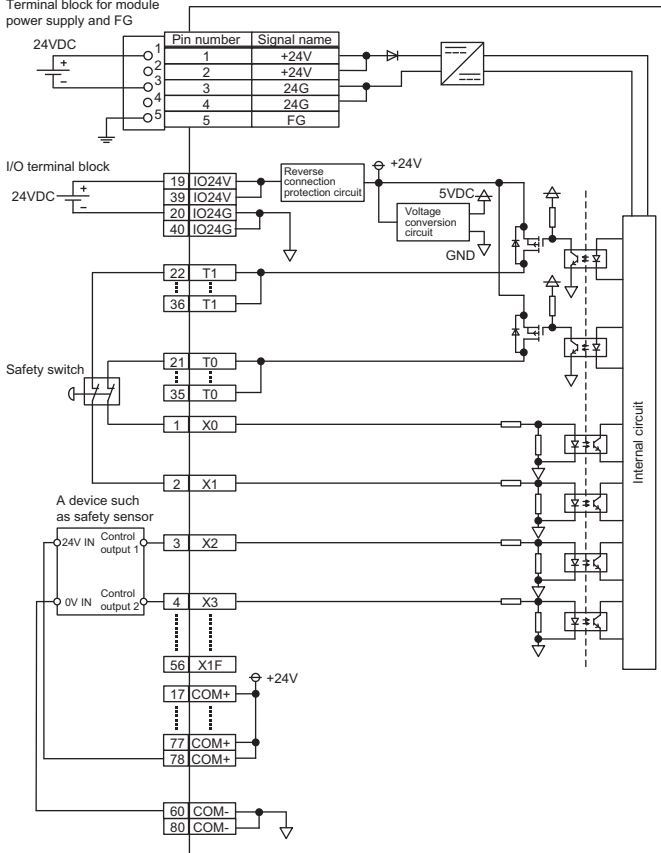

English	French
Terminal block for module power supply and FG	<i>Bornier pour alimentation du module et FG</i>
Pin number	<i>Broche N°</i>
Signal name	<i>Nom de signal</i>
I/O terminal block	<i>Bornier E/S</i>
Safety switch	<i>Commutateur de sécurité</i>
A device such as safety sensor	<i>Dispositif du genre capteur de sécurité</i>
Control output 1	<i>Sortie de commande 1</i>
Control output 2	<i>Sortie de commande 2</i>
Reverse connection protection circuit	<i>Circuit de protection contre la connexion inverse</i>
Voltage conversion circuit	<i>Circuit de conversion de tension</i>
Internal circuit	<i>Circuit interne</i>

Wiring example of the NZ2GFSS2-8D

Exemple de câblage du NZ2GFSS2-8D

■ Example of wiring to a switch with NC/NC contact and to a safety sensor

■ Exemple de câblage à un commutateur à contact NC/NC et à un capteur de sécurité.

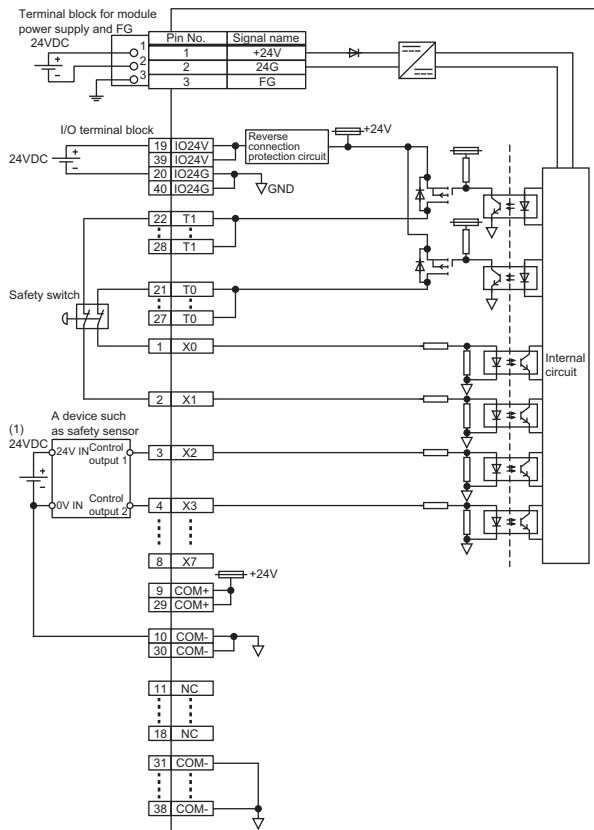

English	French
Terminal block for module power supply and FG	<i>Bornier pour alimentation du module et FG</i>
Pin number	<i>Broche N°</i>
Signal name	<i>Nom de signal</i>
I/O terminal block	<i>Bornier E/S</i>
Safety switch	<i>Commutateur de sécurité</i>
A device such as safety sensor	<i>Dispositif du genre capteur de sécurité</i>
Control output 1	<i>Sortie de commande 1</i>
Control output 2	<i>Sortie de commande 2</i>
Reverse connection protection circuit	<i>Circuit de protection contre la connexion inverse</i>
Internal circuit	<i>Circuit interne</i>

English	French
Terminal block for module power supply and FG	<i>Bornier pour alimentation du module et FG</i>
Pin number	<i>Broche N°</i>
Signal name	<i>Nom de signal</i>
I/O terminal block	<i>Bornier E/S</i>
Safety relay	<i>Relais de sécurité</i>
Load	<i>Charge</i>
Reverse connection protection circuit	<i>Circuit de protection contre la connexion inverse</i>
Internal circuit	<i>Circuit interne</i>

Wiring example of the NZ2GFSS2-16DTE

Exemple de câblage du NZ2GFSS2-16DTE

- Example of wiring to a switch with NC/NC contact and to a safety sensor
- *Exemple de câblage à un commutateur à contact NC/NC et à un capteur de sécurité.*

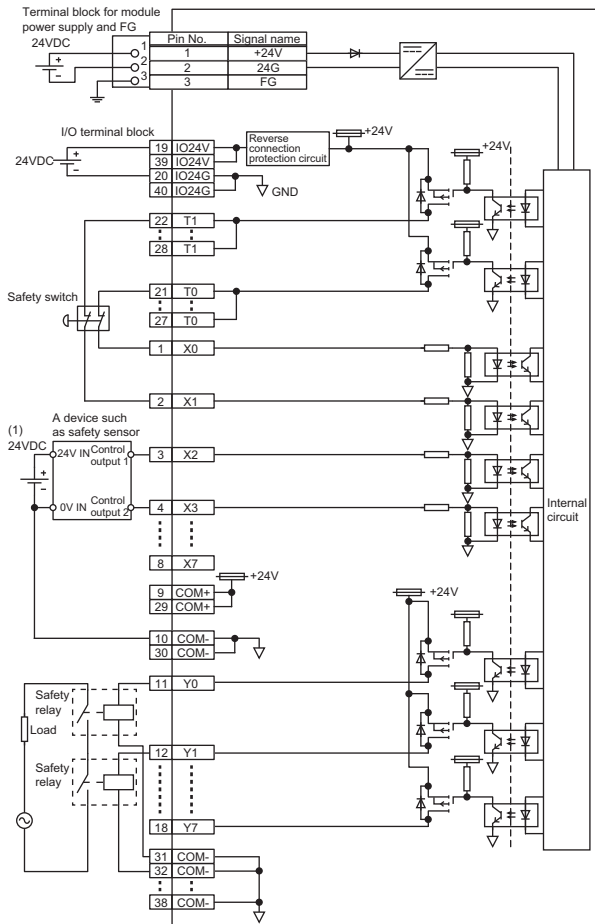

(1) The COM+ terminals can supply 24VDC as well.

(1) Les bornes COM+ peuvent également fournir une alimentation de 24 VCC.

English	French
Terminal block for module power supply and FG	<i>Bornier pour alimentation du module et FG</i>
Pin number	<i>Broche N°</i>
Signal name	<i>Nom de signal</i>
I/O terminal block	<i>Bornier E/S</i>
Safety switch	<i>Commutateur de sécurité</i>
A device such as safety sensor	<i>Dispositif du genre capteur de sécurité</i>
Control output 1	<i>Sortie de commande 1</i>
Control output 2	<i>Sortie de commande 2</i>
Safety relay	<i>Relais de sécurité</i>
Load	<i>Charge</i>
Reverse connection protection circuit	<i>Circuit de protection contre la connexion inverse</i>
Voltage conversion circuit	<i>Circuit de conversion de tension</i>
Internal circuit	<i>Circuit interne</i>

Wiring example of the NZ2EXSS2-8TE

Exemple de câblage du NZ2EXSS2-8TE

■ Example of wiring to a safety relay

■ Exemple de câblage d'un relais de sécurité

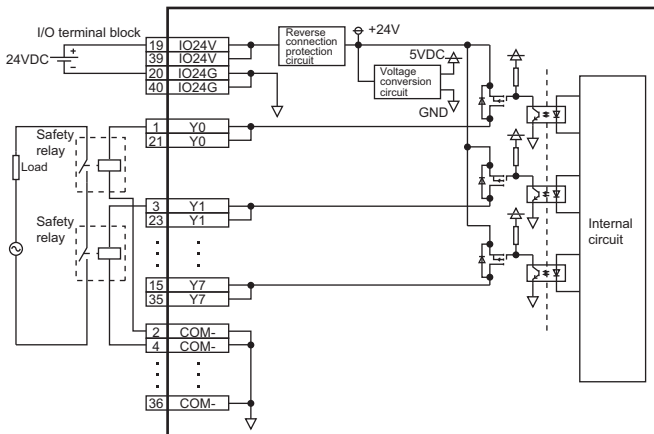

English	French
I/O terminal block	Bornier E/S
Safety relay	Relais de sécurité
Load	Charge
Reverse connection protection circuit	Circuit de protection contre la connexion inverse
Voltage conversion circuit	Circuit de conversion de tension
Internal circuit	Circuit interne

6 MODULE STATUS AFTER POWER-ON AND LED STATUS

The safety remote I/O module performs initial processing (such as self-diagnostics) after the power-on or reset. The operating status of the safety remote I/O module after initial processing can be checked with LEDs of each module.

No.	Name	Description
(1)	PW LED	Indicates the power supply status. On: Power supply ON Off: Power supply OFF
(2)	RUN LED	Indicates the operating status. On: Operating normally, in initial processing Off: A major error has occurred.
(3)	MODE LED	Indicates the mode status. On: In online mode, in initial processing Flashing: In unit test mode Off: The unit test is completed.
(4)	D LINK LED	Indicates the data link status. On: Data link (cyclic transmission being performed), in initial processing Flashing: Data link (cyclic transmission stopped) ^{*1} Off: Data link not in operation (disconnected)
(5)	SAFETY LED	Indicates the safety communication connection status. On: In safety communication connection, in initial processing Flashing: Checking the position of the setting target module Off: Safety communications being disconnected
(6)	ERR. LED	Indicates the error status. On: An error has occurred, in initial processing Flashing: A minor error has occurred. ^{*2} Off: Operating normally
(7)	I/O PW LED	Indicates the status of the power supply from the external power supply. On: External power supply ON Off: External power supply OFF

*1 If cyclic transmission stops only at the master station, the D LINK LED is on because the safety remote I/O module continues cyclic transmission.

*2 After a minor error has been eliminated, the LED flashes for 5 seconds or longer and turns off.

7 EMC, LOW VOLTAGE, AND MACHINERY DIRECTIVES

In each country, laws and regulations concerning electromagnetic compatibility (EMC) and electrical safety are enacted. For the products sold in the European countries, compliance with the EU's EMC Directive has been a legal obligation as EMC regulation since 1996, as well as the EU's Low Voltage Directive as electrical safety regulation since 1997.

Also, compliance with the EU's Machinery Directive has been a legal obligation since 1995.

Manufacturers who recognize their products are compliant with the EMC and Low Voltage Directives are required to attach a "CE marking" on their products in European countries.

Each country works to make their regulatory requirements consistent across countries based on international standards. When the requirements are consistent, measures to comply with the EMC and electrical safety regulations become common across countries.

The UK and South Korea have enacted EMC regulations whose requirements are consistent with those of the EMC Directive.

The UK has also enacted electrical safety regulations whose requirements are consistent with those of the Low Voltage Directive. In this section, the requirements of the EMC and Low Voltage Directives are described as examples of those of the EMC and electrical safety regulations.

7.1 Measures to Comply with the EMC Directive

The EMC Directive sets requirements for emission (conducted and radiated electromagnetic interference emitted by a product) and immunity (the ability of a product not to be influenced by externally generated electromagnetic interference).

This section describes the precautions for machinery constructed with the MELSEC iQ-R series modules to comply with the EMC Directive.

These precautions are based on the requirements of the EMC Directive and the harmonized standards. However, they do not guarantee that the entire machinery constructed according to the descriptions complies with the EMC Directive.

The manufacturer of the machinery must determine the testing method for compliance and declare conformity to the EMC Directive.

EMC Directive related standards

■ Emission requirements

Standard: EN61131-2:2007

Test item	Test details	Standard value
CISPR16-2-3 Radiated emission ^{*2}	Radio waves from the product are measured.	• 30 to 230MHzQP: 40dB μ V/m (measured at 10m distance) ^{*1} • 230 to 1000MHzQP: 47dB μ V/m (measured at 10m distance)
CISPR16-2-1, CISPR16-1-2 Conducted emission ^{*2}	Noise from the product to the power line is measured.	• 0.15 to 0.5MHzQP: 79dB, Mean: 66dB ^{*1} • 0.5 to 30MHzQP: 73dB, Mean: 60dB

^{*1} QP: Quasi-Peak value, Mean: Average value

^{*2} The module is an open-type device (a device designed to be housed in other equipment) and must be installed inside a conductive control panel. The tests were conducted with the module installed in a control panel, applying the maximum rated input voltage of the power supply module.

■ Immunity requirements

Standard: EN61131-2:2007

Test item	Test details	Standard value
EN61000-4-2 Electrostatic discharge immunity ^{*1}	Immunity test in which static electricity is applied to the cabinet of the equipment	<ul style="list-style-type: none"> • 8kV Air discharge • 4kV Contact discharge
EN61000-4-3 Radiated, radio-frequency, electromagnetic field immunity ^{*1}	Immunity test in which electric fields are irradiated to the product	80% AM modulation @1kHz <ul style="list-style-type: none"> • 80 to 1000MHz: 10V/m • 1.4 to 2.0GHz: 3V/m • 2.0 to 2.7GHz: 1V/m
EN61000-4-4 Fast transient burst immunity ^{*1}	Immunity test in which burst noise is applied to the power supply line and signal line	<ul style="list-style-type: none"> • AC/DC main power, I/O power, and AC I/O (unshielded) lines: 2kV • DC I/O, analog, and communication lines: 1kV
EN61000-4-5 Surge immunity ^{*1}	Immunity test in which lightning surge is applied to the power supply line and signal line	<ul style="list-style-type: none"> • AC power, AC I/O power, and AC I/O (unshielded) lines: 2kV CM, 1kV DM • DC power and DC I/O power lines: 0.5kV CM, 0.5kV DM • DC I/O, AC I/O (shielded), analog^{*2}, and communication lines: 1kV CM
EN61000-4-6 Conducted RF immunity ^{*1}	Immunity test in which high frequency noise is applied to the power supply line and signal line	0.15 to 80MHz 80% AM modulation @1kHz, 10Vrms
EN61000-4-8 Power-frequency magnetic field immunity ^{*1}	Immunity test in which the product is installed in the inductive magnetic field	50/60Hz, 30A/m
EN61000-4-11 Voltage dips and interruption immunity ^{*1}	Immunity test in which power supply voltage is momentarily interrupted	<ul style="list-style-type: none"> • 0%, 0.5 period, starting at zero crossing • 0%, 250/300 period (50/60Hz) • 40%, 10/12 period (50/60Hz) • 70%, 25/30 period (50/60Hz)

*1 The module is an open-type device (a device designed to be housed in other equipment) and must be installed inside a conductive control panel. The tests were conducted with the module installed in a control panel.

*2 The accuracy of an analog-digital converter module may temporarily vary within $\pm 10\%$.

Installation in a control panel

The module is an open-type device and must be installed inside a control panel.

Remote modules on each network must be also installed inside the control panel. Waterproof type remote modules can be installed outside the control panel.

Installing the module inside the control panel ensures safety as well as effective shielding of electromagnetic noise emitted from the module.

■ Control panel

- Use a conductive control panel.
- When securing the top or bottom plate using bolts, cover the grounding part on the control panel so that the part will not be painted.
- To ensure electrical contact between inner plates and the control panel, mask off the bolt installation areas of each inner plate so that conductivity can be ensured in the largest area.
- Ground the control panel with a thick ground cable so that low impedance can be ensured even at high frequencies.
- Keep the diameter of the holes on the control panel to 10cm or shorter. If the diameter is longer than 10cm, radio waves may leak. In addition, because radio waves leak through a clearance between the control panel and its door, reduce the clearance as much as possible. The leakage of radio waves can be suppressed by directly applying an EMI gasket on the paint surface.

The tests were conducted by Mitsubishi Electric Corporation using a control panel having damping characteristics of 37dB (maximum) and 30dB (average) (measured at 3m distance, 30 to 300MHz).

■ Power cable and ground cable

Near the power supply part, provide a grounding point to the control panel. Ground the FG terminal with the thickest and shortest possible ground cable (2mm², 30cm or shorter).

■ Noise filter (power supply line filter)

A noise filter is a component which has an effect on conducted noise. Using the noise filter can suppress more noise. The noise filter has the effect of reducing conducted noise of 10MHz or less.

Connect a noise filter to the external power supply of a main module and the external power supply of an extension module.

The precautions for attaching a noise filter are described below.

- Do not bundle the cables on the input side and output side of the noise filter. If bundled, the output side noise will be induced into the input side cables from which the noise was filtered.

• Problematic example
Noise is induced when the input and output cables are bundled.

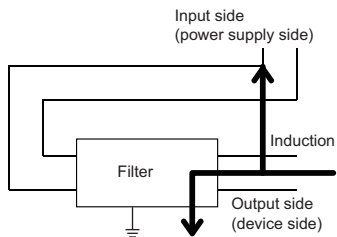

• Modification example
Install the input and output cables separately.

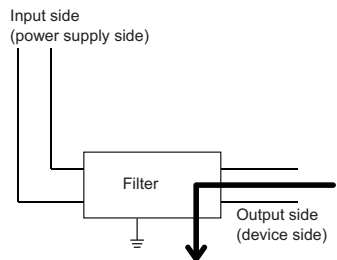

- Ground the ground terminal of the noise filter to the ground point of the control panel with the shortest possible cable (approximately 10cm).

Cables extended out of the control panel

Use a shielded cable for a cable extended out of the control panel such as an I/O signal line (including a common line) and cable for communications.

If a shielded cable is not used or not grounded properly, the noise immunity will not meet the requirement.

■ Cables for the CC-Link IE Field Network

The precautions for using CC-Link IE Field Network cables are described below.

- Shielded cables should be used for the CC-Link IE Field Network. Strip a part of the jacket as shown below and ground the exposed shield in the largest possible area.

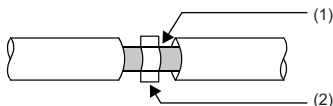

- (1) Shield
- (2) Clamp fitting

■ Grounding the cable clamp

Use shielded cables for external wiring and ground the shields of the shielded cables to the control panel with an AD75CK cable clamp (manufactured by Mitsubishi). Ground the shields within 20 to 30cm from the module.

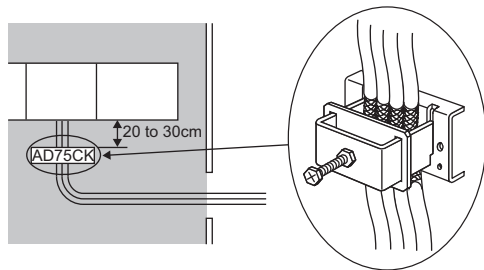

For details on the AD75CK, refer to the following.

📖 AD75CK-type Cable Clamping Instruction Manual

■ Ferrite core

A ferrite core is effective for reducing radiated noise in the 30MHz to 100MHz frequency band. It is recommended to install a ferrite core if a shield cable extended out of the control panel does not provide sufficient shielding effects.

Note that the ferrite core must be attached at the position closest to the cable hole inside the control panel. If attached at an improper position, the ferrite core will not produce any effect. Install a ferrite core to each power cable as shown below.

- Ferrite core used for the tests conducted by Mitsubishi: ESD-SR-250 (manufactured by TOKIN Corporation), ZCAT3035-1330 (manufactured by TDK Corporation)

Ex.

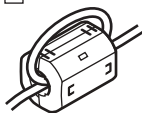

External power supply

- Use an AC/DC power supply adapter for a module power supply or an external power supply.
- Use a CE-marked product for an external power supply and always ground the FG terminal.
(External power supply used for the tests conducted by Mitsubishi: TDK-Lambda DLP-120-24-1, DRJ240-24-1, IDEC PS5R-SF24, PS5R-F24, PS6R-F24)
- Use a power cable of 10m or shorter when connecting it to the module power supply terminal.
- Use a power cable of 30m or shorter when connecting it to the external power supply terminal.

7.2 Requirements for Low Voltage Directive Compliance

Module

The module operates at the rated voltage of 24VDC. The Low Voltage Directive is not applied to the modules that operate at the rated voltage of less than 50VAC and less than 75VDC.

External wiring

■24VDC external power supply

To connect to the module, use the power supply that meets the following conditions:

- SELV (Safety Extra Low Voltage): Product with reinforced insulation from the hazardous potential part (48V or more)
- LVD applicable product
- Output voltage specifications: 24VDC (ripple ratio: 5% or less) (allowable voltage range: 20.4 to 28.8VDC)

■External devices

For external devices connected to a module, use the device of which insulation between the interface circuit section to the module and the dangerous voltage circuit section is reinforced (if the device internally has a dangerous voltage circuit section).

■Reinforced insulation

The reinforced insulation covers the withstand voltages shown in the table below.

Rated voltage of dangerous voltage section	Surge voltage withstand (1.2/50 μ s)
150VAC or less	2500V
300VAC or less	4000V

7.3 Requirements to Comply with the Machinery Directive

The Machinery Directive (2006/42/EC) requires that machinery satisfy the three pillars of safety: mechanical safety, electrical safety, and worker safety.

This product is suitable for establishing safety functions for general industrial machinery and complies with the Machinery Directive (2006/42/EC).

Before using this product, please read this manual, the relevant manuals, and the safety standards carefully and pay full attention to safety to handle the product correctly.

The descriptions are based on the requirements of the Machinery Directive and the harmonized standards. However, they do not guarantee that the entire machinery constructed according to the descriptions complies with the Machinery Directive. The manufacturer of the machinery must determine the testing method for compliance and declare conformity to the Machinery Directive.

Standard: EN61000-6-7: 2015

Test item	Test description	Value specified in standard
EN61000-4-2 EN61000-6-7 Electrostatic discharge immunity ^{*1}	Immunity test in which static electricity is applied to the cabinet of the equipment	8kV Contact discharge
EN61000-4-3 EN61000-6-7 Radiated, radio-frequency, electromagnetic field immunity ^{*1}	Immunity test in which electric fields are irradiated to the product	80% AM modulation @1kHz • 80 to 1000MHz: 20V/m • 1.4 to 2.0GHz: 10V/m • 2.0 to 6.0GHz: 3V/m • 84.000, 137 to 174, 219.500, 380 to 400, 420 to 470, 698 to 960MHz: 20V/m • 1.24 to 1.30, 1.428 to 2.0GHz: 10V/m • 2.0 to 2.7, 3.3 to 3.6, 5.15 to 5.925GHz: 3V/m
EN61000-4-4 Fast transient burst immunity ^{*1}	Immunity test in which burst noise is applied to the power supply line and signal line	• AC main power line: 4kV • DC main power line: 2kV • I/O power, DC I/O and communication lines: 2kV
EN61000-4-5 EN61000-6-7 Surge immunity ^{*1}	Immunity test in which lightning surge is applied to the power supply line and signal line	• AC power line: 4kV CM, 2kV DM • DC I/O Power, DC I/O, communication lines: 2kV CM
EN61000-4-6 EN61000-6-7 Conducted RF immunity ^{*1}	Immunity test in which high frequency noise is applied to the power supply line and signal line	80% AM modulation @1kHz • 0.15 to 80MHz: 20V • 3.39, 6.780, 13.560, 27.120, 40.680MHz: 20V
EN61000-4-11 Voltage dips and interruption immunity ^{*1}	Immunity test in which power supply voltage is momentarily interrupted	• 0%, 1 period, starting at zero crossing • 0%, 250/300 period (50/60Hz) • 40%, 10/12 period (50/60Hz) • 70%, 25/30 period (50/60Hz)
EN61000-4-6-16 EN61000-6-7 Conducted common-mode voltage immunity ^{*1}	Immunity test in which common-mode noise is applied to the power lines and signal lines	• 1.5 to 15kHz: 1 to 10V • 15 to 150kHz: 10V • 16.7, 50, 60, 150, 180Hz: 10V (continuously) • 16.7, 50, 60Hz: 100V for short period of time (1s)

^{*1} The module is an open-type device (a device designed to be housed in other equipment) and must be installed inside a conductive control panel. The tests were conducted with the module installed in a control panel.

8 PRECAUTIONS FOR USING A SAFETY PROGRAMMABLE CONTROLLER

Users must prove that their entire safety system complies with the safety standards and the Machinery Directive. The third-party certification organization will validate the safety of product for the entire safety system, including a safety programmable controller and safety components.

Calculation of the target failure measure (PFDavg/PFH)

To establish a safety system, calculate the target failure measure (PFDavg/PFH) for each safety application (safety function) based on the PFDavg/PFH values of the safety programmable controller and connected safety components. The target failure measure (PFDavg/PFH) is the reliability target value for each Safety Integrity Level (SIL) defined in IEC61508 and can be calculated by the following formula.

- $PFD_{avg}/PFH = A + B + C + D$ Calculation formula of PFDavg/PFH

Variable	Definition
A ^{*1}	PFDavg/PFH of the safety CPU set (Example: Total PFDavg/PFH ^{*2} of the Safety CPU and the safety function module)
B	PFDavg/PFH of the safety remote I/O module (1) When safety input device(s) and safety output device(s) are connected to the same safety remote I/O module: $B = B1$ (2) When safety input device(s) and safety output device(s) are connected to different safety remote I/O modules: $B = B1 + B2$
B1	PFDavg/PFH of the safety remote I/O module to which safety input device(s) is connected
B2	PFDavg/PFH of the safety remote I/O module to which safety output device(s) is connected
C ^{*3}	PFDavg/PFH of safety input device(s)
D ^{*3}	PFDavg/PFH of safety output device(s)

*1 For the PFDavg/PFH value of A, refer to the manual for the safety CPU set used.

*2 For the total PFDavg/PFH value, refer to the following.

□ □ MELSEC iQ-R Safety Application Guide

*3 For the PFDavg/PFH value of C or D, refer to the manual for the safety component used.

■ PFDavg values of the safety remote I/O module

The following tables show the PFDavg values for the safety remote I/O module.

- Each proof test interval is the duration of product use.
- The PFDavg values are for when the module is used at the ambient temperature of 40°C.

Main module		Proof test interval
		5 years
PFDavg for the safety remote I/O module	NZ2GFSS2-16DTE	2.52×10^{-5}
	NZ2GFSS2-8D	2.44×10^{-5}
	NZ2GFSS2-8TE	2.43×10^{-5}
	NZ2GFSS2-32D ^{**2}	6.07×10^{-6}

*1 The value is 3.54×10^{-5} for the NZ2GFSS2-32D with the serial number (16 digits) that satisfies both of the following: the first 2 digits are "24" or earlier; the sixth digit is "7" or earlier.

*2 The following table shows the PFDavg values for when the main module (NZ2GFSS2-32D) is connected to the extension module (NZ2EXSS2-8TE).

Main module (NZ2GFSS2-32D) connected to Extension module (NZ2EXSS2-8TE)		Proof test interval
Serial number (16 digits) of the NZ2GFSS2-32D	Serial number (16 digits) of the NZ2EXSS2-8TE	5 years
The number satisfying both of the following: • The first 2 digits are "24" or earlier. • The sixth digit is "7" or earlier.	The number satisfying both of the following: • The first 2 digits are "24" or earlier. • The sixth digit is "5" or earlier.	4.66×10^{-5}
	The number other than the above	3.62×10^{-5}
The number other than the above	The number satisfying both of the following: • The first 2 digits are "24" or earlier. • The sixth digit is "5" or earlier.	1.73×10^{-5}
	The number other than the above	6.91×10^{-6}

■ PFH values of the safety remote I/O module

The following tables show the PFH values for the safety remote I/O module.

- Each proof test interval is the duration of product use.
- The PFH values are for when the module is used at the ambient temperature of 40°C.

Main module		Proof test interval
		5 years
PFH for the safety remote I/O module	NZ2GFSS2-16DTE	1.05×10^{-8}
	NZ2GFSS2-8D	7.31×10^{-9}
	NZ2GFSS2-8TE	6.67×10^{-9}
	NZ2GFSS2-32D ^{*1*2}	2.18×10^{-9}

*1 The value is 3.55×10^{-9} for the NZ2GFSS2-32D with the serial number (16 digits) that satisfies both of the following: the first 2 digits are "24" or earlier; the sixth digit is "7" or earlier.

*2 The following table shows the PFH values for when the main module (NZ2GFSS2-32D) is connected to the extension module (NZ2EXSS2-8TE).

Main module (NZ2GFSS2-32D) connected to Extension module (NZ2EXSS2-8TE)		Proof test interval
Serial number (16 digits) of the NZ2GFSS2-32D	Serial number (16 digits) of the NZ2EXSS2-8TE	5 years
The number satisfying both of the following: • The first 2 digits are "24" or earlier. • The sixth digit is "7" or earlier.	The number satisfying both of the following: • The first 2 digits are "24" or earlier. • The sixth digit is "5" or earlier.	4.78×10^{-9}
	The number other than the above	5.12×10^{-9}
The number other than the above	The number satisfying both of the following: • The first 2 digits are "24" or earlier. • The sixth digit is "5" or earlier.	3.41×10^{-9}
	The number other than the above	3.74×10^{-9}

PL evaluation described in ISO 13849-1

For the PL evaluation described in ISO 13849-1, use the $MTTF_D$ (mean time to dangerous failure) and the DC_{avg} (average diagnostic coverage) listed in the following table.

- The $MTTF_D$ and DC_{avg} are for when the module is used at the ambient temperature of 40°C.

Main module		$MTTF_D$	DC_{avg}
Safety remote I/O module	NZ2GFSS2-16DTE	142 years	97.3%
	NZ2GFSS2-8D	204 years	96.6%
	NZ2GFSS2-8TE	223 years	96.3%
	NZ2GFSS2-32D ^{*2}	545 years ^{*2}	98.3% ^{*2}

*1 For the NZ2GFSS2-32D with the serial number (16 digits) that satisfies both of the following: the first 2 digits are "24" or earlier; the sixth digit is "7" or earlier, the $MTTF_D$ and the DC_{avg} are as shown below.

$MTTF_D$: 214 years, DC_{avg} : 95.1%

*2 The following table shows the $MTTF_D$ and the DC_{avg} for when the main module (NZ2GFSS2-32D) is connected to the extension module (NZ2EXSS2-8TE).

Main module (NZ2GFSS2-32D) connected to Extension module (NZ2EXSS2-8TE)		$MTTF_D$	DC_{avg}
Serial number (16 digits) of the NZ2GFSS2-32D	Serial number (16 digits) of the NZ2EXSS2-8TE		
The number satisfying both of the following: <ul style="list-style-type: none"> The first 2 digits are "24" or earlier. The sixth digit is "7" or earlier. 	The number satisfying both of the following: <ul style="list-style-type: none"> The first 2 digits are "24" or earlier. The sixth digit is "5" or earlier. 	156 years	96.1%
	The number other than the above		165 years
The number other than the above	The number satisfying both of the following: <ul style="list-style-type: none"> The first 2 digits are "24" or earlier. The sixth digit is "5" or earlier. 	281 years	98.6%
	The number other than the above		309 years

9 Declaration of Conformity

9.1 EU DECLARATION OF CONFORMITY



ORIGINAL

EU DECLARATION OF CONFORMITY

We,
Manufacturer : MITSUBISHI ELECTRIC CORPORATION
Address : TOKYO 100-8310, JAPAN
(Place of Declare)
Brand Name :  MITSUBISHI ELECTRIC
declare under our sole responsibility that the product
Description : Programmable Controller
Type of Model : Remote I/O modules
Notice : Refer to next page about each type name

to which this declaration relates is in conformity with the following standard and directive.

Directive		Harmonized Standard	Notified Body
EMC Directive	2014/30/EU	EN61131-2:2007	—
Machinery Directive	2006/42/EC	EN ISO 13849-1 : 2015	1
RoHS Directive	2011/65/EU, (EU)2015/863*1	EN IEC63000:2018	—

*1: Category 9 "Industrial monitoring and control instruments" is applicable.

This declaration is based on the conformity assessment of following Notified Body			
No.	Name and Address	Identification Number	Issued certificate No.
1	TÜV RHEINLAND INDUSTRIE SERVICE GMBH, Am Grauen Stein, 51105 Köln, Germany	0035	01/205/5449.02/21

Authorized representative in Europe (The person authorized to compile the Technical file or relevant Technical documentation)	
Hartmut Pütz FA Product Marketing, Director, MITSUBISHI ELECTRIC EUROPE B.V., German Branch Mitsubishi-Electric-Platz 1, 40882 Ratingen, Germany Issue Date (Date of Declaration): 8 May, 2023	

Signed for and on behalf of

(Signature) Kazuki Yamanaka

[Kazuki Yamanaka]
Senior Manager, I/O Module Development Section
FA Systems Dept.2
MITSUBISHI ELECTRIC CORPORATION NAGOYA WORKS

Appendix List of type name to declare

Type name	Serial No.
NZ2EXSS2-8TE	#####-#
NZ2GFSS2-16DTE	#####-#
NZ2GFSS2-32D	#####-#
NZ2GFSS2-8D	#####-#
NZ2GFSS2-8TE	#####-#

(# 0-9, A-Z)

9.2 UK DECLARATION OF CONFORMITY



ORIGINAL

UK DECLARATION OF CONFORMITY

We,
Manufacturer : MITSUBISHI ELECTRIC CORPORATION
Address : TOKYO 100-8310, JAPAN
(Place of Declare)
Brand Name :  MITSUBISHI ELECTRIC
declare under our sole responsibility that the product
Description : Programmable Controller
Type of Model : Remote I/O modules
Notice : Refer to next page about each type name

to which this declaration relates is in conformity with the following standard and legislation.

Legislation	Designated Standard	Approved Body
Electromagnetic Compatibility Regulations 2016	EN 61131-2:2007	—
Supply of Machinery (Safety) Regulations 2008	EN ISO 13849-1:2015	1
The Restriction of the Use of Certain Hazardous Substances in Electrical and Electronic Equipment Regulations 2012	EN IEC 63000:2018	—

This declaration is based on the conformity assessment of following Approved Body

No.	Name and Address	Identification Number	Issued certificate No.
1	TUV Rheinland UK Ltd, Friars Gate (Third Floor), 1011 Stratford Road, Shirley, Solihull B90 4BN, United Kingdom	2571	01/205U/5449.00/22

Issue Date (Date of Declaration): 31 Aug. 2022

Signed for and on behalf of

(Signature) Hisafumi Komoto

[Hisafumi Komoto]
Senior Manager, FA Remote I/O Module Development Section
FA Systems Dept.2
MITSUBISHI ELECTRIC CORPORATION NAGOYA WORKS

Appendix List of type name to declare

Type name	Serial No.
NZ2EXSS2-8TE	#####-#
NZ2GFSS2-16DTE	#####-#
NZ2GFSS2-32D	#####-#
NZ2GFSS2-8D	#####-#
NZ2GFSS2-8TE	#####-#

(# 0-9, A-Z)

REVISIONS

*The manual number is given on the bottom left of the front cover.

Print date	*Manual number	Revision
July 2015	IB(NA)-0800542-A	First edition
October 2015	IB(NA)-0800542-B	■Added or modified parts SAFETY PRECAUTIONS
December 2016	IB(NA)-0800542-C	■Added or modified parts Chapter 7, 9
May 2018	IB(NA)-0800542-D	■Added models NZ2GFSS2-8D, NZ2GFSS2-8TE, NZ2GFSS2-16DTE
May 2019	IB(NA)-0800542-E	■Added or modified parts SAFETY PRECAUTIONS, Section 5.2, Chapter 8 ■Deleted parts Section 3.3
April 2021	IB(NA)-0800542-F	■Added or modified parts SAFETY PRECAUTIONS, CONDITIONS OF USE FOR THE PRODUCT
November 2021	IB(NA)-0800542-G	■Added or modified parts Chapter 7, 9
March 2022	IB(NA)-0800542-H	■Added or modified parts Chapter 7, Section 7.1, 7.3, Chapter 8, 9
August 2023	IB(NA)-0800542-I	■Added or modified parts Chapter 5, 7, 9

This manual confers no industrial property rights or any rights of any other kind, nor does it confer any patent licenses. Mitsubishi Electric Corporation cannot be held responsible for any problems involving industrial property rights which may occur as a result of using the contents noted in this manual.

© 2015 MITSUBISHI ELECTRIC CORPORATION

WARRANTY

Please confirm the following product warranty details before using this product.

1. Limited Warranty and Product Support.

- a. Mitsubishi Electric Company ("MELCO") warrants that for a period of eighteen (18) months after date of delivery from the point of manufacture or one year from date of Customer's purchase, whichever is less, Mitsubishi MELSEC Safety programmable logic controllers (the "Products") will be free from defects in material and workmanship.
- b. At MELCO's option, for those Products MELCO determines are not as warranted, MELCO shall either repair or replace them or issue a credit or return the purchase price paid for them.
- c. For this warranty to apply:
 - (1) Customer shall give MELCO (i) notice of a warranty claim to MELCO and the authorized dealer or distributor from whom the Products were purchased, (ii) the notice shall describe in reasonable details the warranty problem, (iii) the notice shall be provided promptly and in no event later than thirty (30) days after the Customer knows or has reason to believe that Products are not as warranted, and (iv) in any event, the notice must be given within the warranty period;
 - (2) Customer shall cooperate with MELCO and MELCO's representatives in MELCO's investigation of the warranty claim, including preserving evidence of the claim and its causes, meaningfully responding to MELCO's questions and investigation of the problem, grant MELCO access to witnesses, personnel, documents, physical evidence and records concerning the warranty problem, and allow MELCO to examine and test the Products in question offsite or at the premises where they are installed or used; and
 - (3) If MELCO requests, Customer shall remove Products it claims are defective and ship them to MELCO or MELCO's authorized representative for examination and, if found defective, for repair or replacement. The costs of removal, shipment to and from MELCO's designated examination point, and reinstallation of repaired or replaced Products shall be at Customer's expense.
 - (4) If Customer requests and MELCO agrees to effect repairs onsite at any domestic or overseas location, the Customer will pay for the costs of sending repair personnel and shipping parts. MELCO is not responsible for any re-commissioning, maintenance, or testing on-site that involves repairs or replacing of the Products.
- d. Repairs of Products located outside of Japan are accepted by MELCO's local authorized service facility centers ("FA Centers"). Terms and conditions on which each FA Center offers repair services for Products that are out of warranty or not covered by MELCO's limited warranty may vary.
- e. Subject to availability of spare parts, MELCO will offer Product repair services for (7) years after each Product model or line is discontinued, at MELCO's or its FA Centers' rates and charges and standard terms in effect at the time of repair. MELCO usually produces and retains sufficient spare parts for repairs of its Products for a period of seven (7) years after production is discontinued.
- f. MELCO generally announces discontinuation of Products through MELCO's Technical Bulletins. Products discontinued and repair parts for them may not be available after their production is discontinued.

2. Limits of Warranties.

- a. MELCO does not warrant or guarantee the design, specify, manufacture, construction or installation of the materials, construction criteria, functionality, use, properties or other characteristics of the equipment, systems, or production lines into which the Products may be incorporated, including any safety, fail-safe and shut down systems using the Products.
- b. MELCO is not responsible for determining the suitability of the Products for their intended purpose and use, including determining if the Products provide appropriate safety margins and redundancies for the applications, equipment or systems into which they are incorporated.
- c. Customer acknowledges that qualified and experienced personnel are required to determine the suitability, application, design, construction and proper installation and integration of the Products. MELCO does not supply such personnel.
- d. MELCO is not responsible for designing and conducting tests to determine that the Product functions appropriately and meets application standards and requirements as installed or incorporated into the end-user's equipment, production lines or systems.
- e. MELCO does not warrant any Product:
 - (1) repaired or altered by persons other than MELCO or its authorized engineers or FA Centers;
 - (2) subjected to negligence, carelessness, accident, misuse, or damage;
 - (3) improperly stored, handled, installed or maintained;
 - (4) integrated or used in connection with improperly designed, incompatible or defective hardware or software;
 - (5) that fails because consumable parts such as batteries, backlights, or fuses were not tested, serviced or replaced;
 - (6) operated or used with equipment, production lines or systems that do not meet applicable and commensurate legal, safety and industry-accepted standards;
 - (7) operated or used in abnormal applications;
 - (8) installed, operated or used in contravention of instructions, precautions or warnings contained in MELCO's user, instruction and/or safety manuals, technical bulletins and guidelines for the Products;
 - (9) used with obsolete technologies or technologies not fully tested and widely accepted and in use at the time of the Product's manufacture;
 - (10) subjected to excessive heat or moisture, abnormal voltages, shock, excessive vibration, physical damage or other improper environment; or
 - (11) damaged or malfunctioning due to Acts of God, fires, acts of vandals, criminals or terrorists, communication or power failures, or any other cause or failure that results from circumstances beyond MELCO's control.
- f. All Product information and specifications contained on MELCO's website and in catalogs, manuals, or technical information materials provided by MELCO are subject to change without prior notice.
- g. The Product information and statements contained on MELCO's website and in catalogs, manuals, technical bulletins or other materials provided by MELCO are provided as a guide for Customer's use. They do not constitute warranties and are not incorporated in the contract of sale for the Products.

- h. These terms and conditions constitute the entire agreement between Customer and MELCO with respect to warranties, remedies and damages and supersede any other understandings, whether written or oral, between the parties. Customer expressly acknowledges that any representations or statements made by MELCO or others concerning the Products outside these terms are not part of the basis of the bargain between the parties and are not factored into the pricing of the Products.
- i. THE WARRANTIES AND REMEDIES SET FORTH IN THESE TERMS ARE THE EXCLUSIVE AND ONLY WARRANTIES AND REMEDIES THAT APPLY TO THE PRODUCTS.
- j. MELCO DISCLAIMS THE IMPLIED WARRANTIES OF MERCHANTABILITY AND FITNESS FOR A PARTICULAR PURPOSE.

3. Limits on Damages.

- a. MELCO'S MAXIMUM CUMULATIVE LIABILITY BASED ON ANY CLAIMS FOR BREACH OF WARRANTY OR CONTRACT, NEGLIGENCE, STRICT TORT LIABILITY OR OTHER THEORIES OF RECOVERY REGARDING THE SALE, REPAIR, REPLACEMENT, DELIVERY, PERFORMANCE, CONDITION, SUITABILITY, COMPLIANCE, OR OTHER ASPECTS OF THE PRODUCTS OR THEIR SALE, INSTALLATION OR USE SHALL BE LIMITED TO THE PRICE PAID FOR PRODUCTS NOT AS WARRANTED.
- b. Although MELCO has obtained the certification for Product's compliance to the international safety standards IEC61508 and ISO13849-1 from TUV Rheinland, this fact does not guarantee that Product will be free from any malfunction or failure. The user of this Product shall comply with any and all applicable safety standard, regulation or law and take appropriate safety measures for the system in which the Product is installed or used and shall take the second or third safety measures other than the Product. MELCO is not liable for damages that could have been prevented by compliance with any applicable safety standard, regulation or law.
- c. MELCO prohibits the use of Products with or in any application involving power plants, trains, railway systems, airplanes, airline operations, other transportation systems, amusement equipments, hospitals, medical care, dialysis and life support facilities or equipment, incineration and fuel devices, handling of nuclear or hazardous materials or chemicals, mining and drilling, and other applications where the level of risk to human life, health or property are elevated.
- d. MELCO SHALL NOT BE LIABLE FOR SPECIAL, INCIDENTAL, CONSEQUENTIAL, INDIRECT OR PUNITIVE DAMAGES, FOR LOSS OF PROFITS, SALES, OR REVENUE, FOR INCREASED LABOR OR OVERHEAD COSTS, FOR DOWNTIME OR LOSS OF PRODUCTION, FOR COST OVERRUNS, OR FOR ENVIRONMENTAL OR POLLUTION DAMAGES OR CLEAN-UP COSTS, WHETHER THE LOSS IS BASED ON CLAIMS FOR BREACH OF CONTRACT OR WARRANTY, VIOLATION OF STATUTE, NEGLIGENCE OR OTHER TORT, STRICT LIABILITY OR OTHERWISE.

- e. In the event that any damages which are asserted against MELCO arising out of or relating to the Products or defects in them, consist of personal injury, wrongful death and/or physical property damages as well as damages of a pecuniary nature, the disclaimers and limitations contained in these terms shall apply to all three types of damages to the fullest extent permitted by law. If, however, the personal injury, wrongful death and/or physical property damages cannot be disclaimed or limited by law or public policy to the extent provided by these terms, then in any such event the disclaimer of and limitations on pecuniary or economic consequential and incidental damages shall nevertheless be enforceable to the fullest extent allowed by law.
- f. In no event shall any cause of action arising out of breach of warranty or otherwise concerning the Products be brought by Customer more than one year after the cause of action accrues.
- g. Each of the limitations on remedies and damages set forth in these terms is separate and independently enforceable, notwithstanding the unenforceability or failure of essential purpose of any warranty, undertaking, damage limitation, other provision of these terms or other terms comprising the contract of sale between Customer and MELCO.

4. Delivery/Force Majeure.

- a. Any delivery date for the Products acknowledged by MELCO is an estimated and not a promised date. MELCO will make all reasonable efforts to meet the delivery schedule set forth in Customer's order or the purchase contract but shall not be liable for failure to do so.
- b. Products stored at the request of Customer or because Customer refuses or delays shipment shall be at the risk and expense of Customer.
- c. MELCO shall not be liable for any damage to or loss of the Products or any delay in or failure to deliver, service, repair or replace the Products arising from shortage of raw materials, failure of suppliers to make timely delivery, labor difficulties of any kind, earthquake, fire, windstorm, flood, theft, criminal or terrorist acts, war, embargoes, governmental acts or rulings, loss or damage or delays in carriage, acts of God, vandals or any other circumstances reasonably beyond MELCO's control.

5. Choice of Law/Jurisdiction.

These terms and any agreement or contract between Customer and MELCO shall be governed by the laws of the State of New York without regard to conflicts of laws. To the extent any action or dispute is not arbitrated, the parties consent to the exclusive jurisdiction and venue of the federal and state courts located in the Southern District of the State of New York. Any judgment there obtained may be enforced in any court of competent jurisdiction.

6. Arbitration.

Any controversy or claim arising out of, or relating to or in connection with the Products, their sale or use or these terms, shall be settled by arbitration conducted in accordance with the Center for Public Resources (CPR) Rules for Non-Administered Arbitration of International Disputes, by a sole arbitrator chosen from the CPR's panels of distinguished neutrals. Judgment upon the award rendered by the Arbitrator shall be final and binding and may be entered by any court having jurisdiction thereof. The place of the arbitration shall be New York City, New York. The language of the arbitration shall be English. The neutral organization designated to perform the functions specified in Rule 6 and Rules 7.7(b), 7.8 and 7.9 shall be the CPR.

Country/ Region	Sales office/ Tel	Country/ Region	Sales office/ Tel
USA	<p> </p>	Turkey	<p> </p>
Mexico	<p> </p>	UAE	<p> </p>
Brazil	<p> </p>	South Africa	<p> </p>
Germany	<p> </p>	China	<p> </p>
UK	<p> </p>	Korea	<p> </p>
Ireland	<p> </p>	Singapore	<p> </p>
Italy	<p> </p>	Thailand	<p> </p>
Spain	<p> </p>	Vietnam	<p> </p>
France	<p> </p>	Malaysia	<p> </p>
Czech Republic	<p> </p>	Indonesia	<p> </p>
Poland	<p> </p>	India	<p> </p>
Sweden	<p> </p>	Australia	<p> </p>
Russia	<p> </p>		

MITSUBISHI ELECTRIC CORPORATION

HEAD OFFICE: TOKYO BLDG., 2-7-3, MARUNOUCHI, CHIYODA-KU, TOKYO 100-8310, JAPAN
 NAGOYA WORKS: 1-14, YADA-MINAMI 5-CHOME, HIGASHI-KU, NAGOYA 461-8670, JAPAN

When exported from Japan, this manual does not require application to the Ministry of Economy, Trade and Industry for service transaction permission.

Specifications subject to change without notice.