

BCN-PS999-1083-B(1908)MEE
NZ2GFS12A2-14DT

Before Using the Product

Please read this document before use. Keep the document in a safe place for future reference. Make sure that the end users read the document.

SAFETY PRECAUTIONS

(Read these precautions before using this product.)
Before using this product, please read this manual and the relevant manuals carefully and pay full attention to safety to handle the product correctly.
The precautions given in this manual are concerned with this product only. For the safety precautions of the programmable controller system, refer to the user's manual for the CPU module used.
In this manual, the safety precautions are classified into two levels: "▲ WARNING" and "▲ CAUTION".

▲ WARNING	Indicates that incorrect handling may cause hazardous conditions, resulting in death or severe injury.
▲ CAUTION	Indicates that incorrect handling may cause hazardous conditions, resulting in minor or moderate injury or property damage.

Under some circumstances, failure to observe the precautions given under "▲ CAUTION" may lead to serious consequences.
Observe the precautions of both levels because they are important for personal and system safety.
Make sure that the end users read this manual and then keep the manual in a safe place for future reference.

[Design Precautions]

- ▲ WARNING**
- When the safety remote I/O module detects an error in an external power supply or a failure in the module, it turns off the outputs. Configure an external circuit to ensure that the power source of a hazard is shut off by turning off the outputs. Failure to do so may result in an accident due to an incorrect output or malfunction.
 - When a load current exceeding the rated current or an overcurrent caused by a load short-circuit flows, the safety remote I/O module defines it as a fault and turns off the outputs. Note that if the overcurrent state continues for a long time, it may cause smoke and fire. To prevent this, configure an external safety circuit, such as a fuse.
 - At the start-up of the system, if the load power supply is short-circuited by the output wiring of the safety remote I/O module, a load may turn on just after the power-on. Configure an interlock circuit to ensure that the entire system will always operate safely.
 - In the case of a communication failure in the network, data in the master module are held. Check Data link status (each station) (SW00B0 to SW00B7) and configure an interlock circuit in the program to ensure that the entire system will operate safely.
 - When a communication failure occurs in the network, the failed station becomes the following station. Check the communication status information and configure an interlock circuit in the program to ensure that the entire system will operate safely. Failure to do so may result in an accident due to an incorrect output or malfunction.
 - All inputs from remote I/O stations are turned off.
 - All outputs from remote I/O stations are turned off.
 - Do not use any "use prohibited" signals as a safety remote I/O signal and a remote control/monitor signal since they are used by the system. If any of the "use prohibited" signals are used (turned on or off), the correct operation of the module cannot be guaranteed.
 - Do not read/write data from/to the remote register since all areas of the remote register are "use prohibited" areas. If data is read or written from/to the remote register, correct operation of the module cannot be guaranteed.

[Design Precautions]

- ▲ CAUTION**
- Do not install the control lines or communication cables together with the main circuit lines or power cables. Keep a distance of 100mm or more between them. Failure to do so may result in malfunction due to noise.
 - Select the external devices to be connected to the module by referring to the performance specifications in the user's manual and considering the maximum inrush current. Connecting a device exceeding the maximum inrush current may cause malfunction or failure of the module.
 - During control of an inductive load such as a lamp, heater, or solenoid valve, a large current (approximately ten times greater than normal) may flow when the output is turned from off to on. Therefore, use a module that has a sufficient current rating.

[Installation Precautions]

- ▲ WARNING**
- Shut off the load power supply (all phases) used in the system before mounting or removing a module. Failure to do so may result in electric shock or cause the module to fail or malfunction.

[Installation Precautions]

- ▲ CAUTION**
- Use the module in an environment that meets the general specifications in the user's manual for the module. Failure to do so may result in electric shock, fire, malfunction, or damage to or deterioration of the product.
 - Do not directly touch any conductive parts and electronic components of the module. Doing so can cause malfunction or failure of the module.
 - Securely fix the module with mounting screws. Failure to do so may cause the module to fall due to increasing effects of vibrations.
 - Securely connect the cable connectors. Poor contact may cause malfunction.
 - After the first use of the product, do not connect/remove the connectors more than 50 times (IEC 61131-2/JIS B 3502 compliant). Exceeding the limit may cause malfunction.

[Wiring Precautions]

- ▲ WARNING**
- Shut off the load power supply (all phases) used in the system before wiring. Failure to do so may result in electric shock or cause the module to fail or malfunction.

[Wiring Precautions]

- ▲ CAUTION**
- Individually ground the FG metal fitting of the programmable controller with a ground resistance of 100 ohms or less. Failure to do so may result in electric shock or malfunction.
 - Check the rated voltage and terminal layout before wiring to the module, and connect the cables correctly. Connecting a power supply with a different voltage rating or incorrect wiring may cause a fire or failure.
 - Tighten the waterproof caps within the specified torque range. Undertightening can cause short circuit, fire, or malfunction. Overtightening can damage the waterproof cap, resulting in short circuit or malfunction.
 - The module meets IP67 only when all of the waterproof plugs and waterproof caps are attached and the cover of the station number setting switch is securely fixed with a screw.
 - Prevent foreign matter such as dust or wire chips from entering the module. Such foreign matter can cause a fire, failure, or malfunction.
 - Place the cables in a duct or clamp them. If not, dangling cable may swing or inadvertently be pulled, resulting in damage to the module or cables or malfunction due to poor contact.
 - Use UL listed cables in the categories "CYJV" and "PVVA", with the suitable voltage, current, and temperature rating (the operating temperature range of the cables: 75°C or higher) for system installation.
 - Do not install the control lines or communication cables together with the main circuit lines or power cables. Keep a distance of 100mm or more between them. Failure to do so may result in malfunction due to noise.
 - When disconnecting the cable from the module, do not pull the cable by the cable part. For the cable with connector, hold the connector part of the cable. Pulling the cable connected to the module may result in malfunction or damage to the module or cable.
 - When an overcurrent caused by an error of an external device or a failure of the programmable controller flows for a long time, it may cause smoke and fire. To prevent this, configure an external safety circuit, such as a fuse.
 - Wiring and replacement of a module must be performed by qualified maintenance personnel with knowledge of protection against electric shock. For wiring methods, refer to "INSTALLATION AND WIRING" in the user's manual.

[Startup and Maintenance Precautions]

- ▲ WARNING**
- Do not touch any connector while power is on. Doing so will cause electric shock or malfunction.
 - Shut off the load power supply (all phases) used in the system before cleaning the module or retightening screws or connector screws. Failure to do so may cause the module to fail or malfunction.

[Startup and Maintenance Precautions]

- ▲ CAUTION**
- Do not disassemble or modify the module. Doing so may cause failure, malfunction, injury, or a fire.
 - Do not drop or apply strong shock to the module. Doing so may damage the module.
 - Shut off the load power supply (all phases) used in the system before mounting or removing a module. Failure to do so may cause the module to fail or malfunction.
 - After the first use of the product, do not connect/remove the connectors more than 50 times (IEC 61131-2/JIS B 3502 compliant). Exceeding the limit may cause malfunction.
 - Before handling the module or the cable to be connected to the module, touch a conducting object such as a grounded metal to discharge the static electricity from the human body. Failure to do so may cause the module to fail or malfunction.
 - Startup and maintenance of a control panel must be performed by qualified maintenance personnel with knowledge of protection against electric shock. Lock the control panel so that only qualified maintenance personnel can operate it.

[Disposal Precautions]

- ▲ CAUTION**
- When disposing of this product, treat it as industrial waste.

[Transportation Precautions]

- ▲ CAUTION**
- For shipping always use the original packaging.

[Précautions lors de la conception]

- ▲ AVERTISSEMENT**
- Utiliser un module E/S distant de sécurité détecte une erreur dans une alimentation externe et désactive les sorties. Pour se prémunir contre les risques d'alimentation, créer un circuit externe désactivant les sorties du module E/S distant de sécurité. Une configuration incorrect de ce circuit peut être à l'origine d'un accident par suite des sorties erronées ou de dysfonctionnements.
 - Si un courant de charge excédant le courant nominal circule dans le module E/S distant de sécurité ou en cas de surintensité suite à une court-circuit à la charge, le module détecte l'anomalie et désactive les sorties. Si l'intensité excessive du courant dure longtemps, il peut y avoir dégagement de fumée et feu. Pour éviter cela, prévoir un circuit de sécurité externe, avec par exemple un fusible.
 - Un démarrage du système, si un court-circuit s'est produit sur le câblage de sortie de l'alimentation de charge, une charge peut apparaître juste après la mise sous tension. Configurez un circuit de verrouillage pour garantir que l'ensemble du système fonctionnera toujours en toute sécurité.
 - En cas de problème de communication dans le réseau, les données sont gardées en mémoire du module maître. Vérifier l'état de la liaison de données (sur chaque station) (SW00B0 à SW00B7) et constituer dans le programme séquentiel un circuit de verrouillage permettant de garantir la sécurité de fonctionnement de l'ensemble du système.
 - À la survenance d'une panne de communication dans le réseau, la station défaillante se trouve dans l'état suivant:
 - Toutes les entrées en provenance de la station E/S distante sont désactivées.
 - Toutes les sorties de la station E/S distante sont désactivées.
 - N'utilisez aucun « signaux interdits » sous forme de signal de sécurité à distance E/S et un signal de télécommande/monteur étant donné qu'ils sont utilisés par le système. Si l'un des « signaux interdits » est utilisé (activé ou désactivé), le bon fonctionnement du module ne peut pas être garanti.
 - Ne lisez/écrivez pas de données depuis/vers le registre à distance étant donné que toutes les zones du registre à distance sont des zones « d'utilisation interdite ».
 - Si des données sont lues ou écrites à partir d'un registre à distance, le bon fonctionnement du module ne peut pas être garanti.

[Précautions lors de la conception]

- ▲ ATTENTION**
- Ne pas installer les lignes de commande ou câbles de communication avec les lignes des circuits principaux ou câbles d'alimentation. Maintenir entre eux une distance de 100mm au minimum. Faute de quoi, il y a risque de dysfonctionnement ou de bruit.
 - Choisir les appareils externes à raccorder au module en se reportant aux indications de performances dans ce manuel et en tenant compte du courant d'appel maximum. Le raccordement d'un appareil avec un courant d'appel excédant le maximum admissible peut être à l'origine de pannes ou de dysfonctionnements du module.
 - À la commande d'une charge inductive comme une lampe, un réchauffeur ou une électrovanne, un fort courant (jusqu'à 10 fois l'intensité normale) traverse la sortie quand celle-ci passe de OFF à ON. Il faut donc que le module utilisé ait une capacité de courant suffisante.

[Précautions d'installation]

- ▲ AVERTISSEMENT**
- Avant de monter ou de retirer un module, couper l'alimentation électrique côté charge utilisée dans le système (sur toutes les phases). Faute de quoi, il y a risque de choc électrique et de panne ou dysfonctionnement du module.

[Précautions d'installation]

- ▲ ATTENTION**
- Utiliser le module dans un environnement en conformité avec les spécifications générales que présente son Manuel de l'utilisateur. Faute de quoi, il a risque d'électrocution, de départ de feu, de dysfonctionnement, d'endommagement ou de détérioration du produit.
 - Éviter tout contact direct avec les parties conductrices et les composants électroniques du module. Une manipulation incorrecte peut être à l'origine de dysfonctionnements ou de pannes du module.
 - Fixer fermement le module par les vis de fixation. Faute de quoi, l'effet amplifié des vibrations peut entraîner la chute du module.
 - Raccorder fermement les connecteurs des câbles. Tout mauvais contact peut être source de dysfonctionnements.
 - Après la première mise en service du produit, le nombre maximum admissible d'opérations de connexion/retrait des connecteurs est de 50 (selon CEI 61131-2/JIS B 3502). Dépasser la limite peut provoquer des dysfonctionnements.

[Précautions de câblage]

- ▲ AVERTISSEMENT**
- Avant le câblage, couper l'alimentation électrique côté charge utilisée dans le système (sur toutes les phases). Faute de quoi, il y a risque de choc électrique et de panne ou dysfonctionnement du module.

[Précautions de câblage]

- ▲ ATTENTION**
- Mettre à la terre séparément la ferrure FG de l'automate programmable avec une résistance terre de 100 ohms au maximum. Faute de quoi, il y a risque de choc électrique ou de dysfonctionnement.
 - Vérifier la tension nominale et l'affectation des bornes avant le câblage du module et raccorder les câbles correctement. Le raccordement d'une alimentation d'une tension autre que la tension nominale ou une erreur de câblage peut être à l'origine d'un départ de feu ou d'une panne.
 - Serrer les capuchons étanches dans les limites du couple de serrage prescrits. Un serrage insuffisant peut être à l'origine de court-circuit, départ de feu ou dysfonctionnement. Un serrage excessif peut endommager le capuchon étanche et être à l'origine de court-circuit ou dysfonctionnement.

CONDITIONS OF USE FOR THE PRODUCT

- Although MELCO has obtained the certification for Product's compliance to the international safety standards IEC61508, ISO13849-1 from TÜV Rheinland, this fact does not guarantee that Product will be free from any malfunction or failure. The user of this Product shall comply with any and all applicable safety standard, regulation or law and take appropriate safety measures for the system in which the Product is installed or used and shall take the second or third safety measures other than the Product. MELCO is not liable for damages that could have been prevented by compliance with any applicable safety standard, regulation or law.
- MELCO prohibits the use of Products with or in any application involving, and MELCO shall not be liable for a default, a liability for defect warranty, a quality assurance, negligence or other tort and a product liability in these applications.
 - power plants,
 - trains, railway systems, airplanes, airline operations, other transportation systems,
 - hospitals, medical care, dialysis and life support facilities or equipment,
 - amusement equipments,
 - incineration and fuel devices,
 - handling of nuclear or hazardous materials or chemicals,
 - mining and drilling,
 - and other applications where the level of risk to human life, health or property are elevated.

1. Relevant manual

Details of the product are described in the manual shown below (sold separately). Please read the manual and understand the functions and performance of the product to use it correctly.
• CC-Link IE Field Network Waterproof/Dustproof Remote I/O Module (With Safety Functions) User's Manual
SH-082076ENG (13.X)0B

2. Packing list

Check that the following items are included in the package.

Item	Quantity
Module	1
Waterproof cap (M12)	4
Signal label	8
Before Using the Product	Japanese 1 English 1

3. Operating ambient temperature

Use the module in the ambient temperatures of 0 to 55°C.
Température ambiante de fonctionnement
Utiliser ce produit avec une température ambiante entre 0 et 55°C.

4. Wiring

Câblage

4.1 Wiring diagrams

Schémas de câblage

Wiring of connectors for power supply

Câblage des connecteurs de l'alimentation

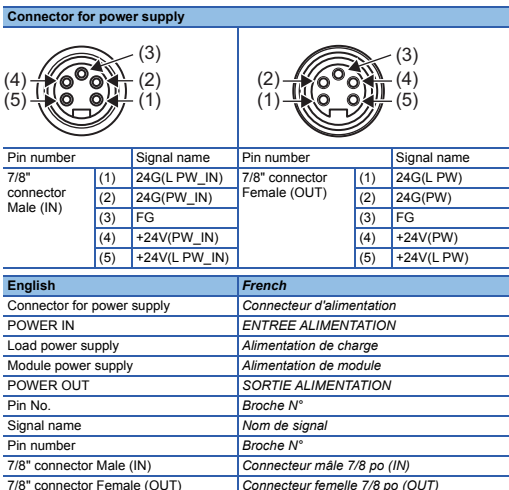
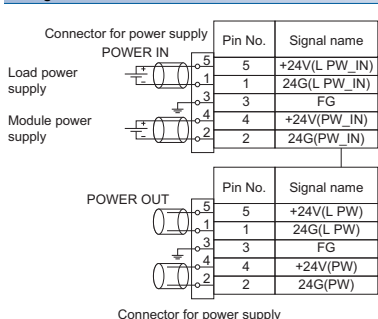

Wiring of connectors for input/output

Câblage des connecteurs d'entrée/sortie

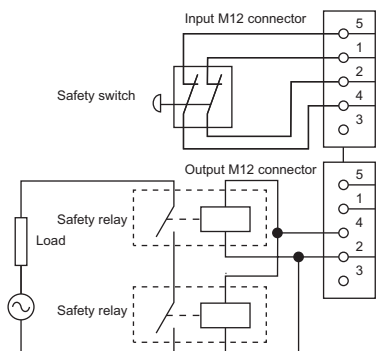

Connector for input/output

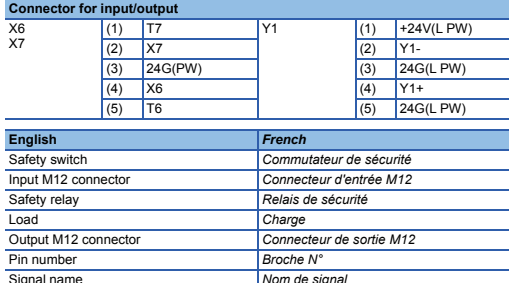
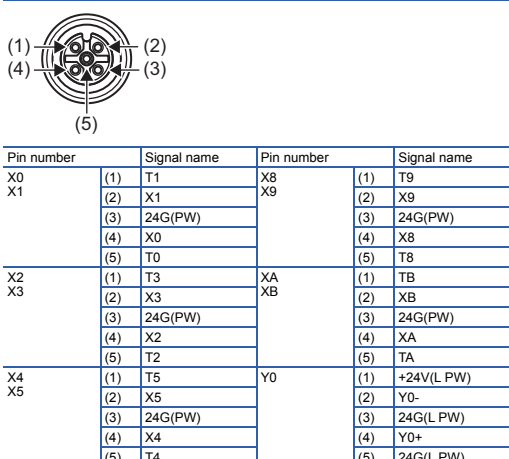

4.2 Wiring products

Produits pour câblage

Wiring of connectors for communication

Câblage des connecteurs de communication
For recommended waterproof connectors for communication, refer to the manual described in 1. Relevant manual.
Pour les connecteurs étanches recommandés destinés à la communication, reportez-vous au manuel décrit au chapitre 1. Manuel correspondant.

Wiring of connectors for power supply

Câblage des connecteurs de l'alimentation
For recommended waterproof connectors for power supply, refer to the manual described in 1. Relevant manual.
Pour les connecteurs étanches recommandés destinés à l'alimentation électrique, reportez-vous au manuel décrit au chapitre 1. Manuel correspondant.

Wiring of connectors for input/output

Câblage des connecteurs d'entrée/sortie
For recommended waterproof connectors for input/output, refer to the manual described in 1. Relevant manual.
Pour les connecteurs étanches recommandés destinés à l'entrée/sortie, reportez-vous au manuel décrit au chapitre 1. Manuel correspondant.

5. EMC and Low Voltage Directives

For EMC and Low Voltage Directives, refer to the manual described in 1. Relevant manual.

6. Information and services

For further information and services, please consult your local Mitsubishi representative.

7. Contact for the co-branded product

molex Molex, LLC www.molex.com

[Précautions de câblage]

- ▲ ATTENTION**
- Le module est en conformité avec IP67 seulement si toutes les prises étanches sont recouvertes des capuchons étanches et si le couvercle du commutateur de sélection de numéro de station est bien fixé au moyen de vis.
 - Veiller à ne pas laisser la poussière, les copeaux métalliques ou d'autres corps étrangers pénétrer dans le module. De telles corps étrangers peuvent être à l'origine d'un départ de feu, d'une panne ou d'un dysfonctionnement.
 - Les câbles doivent être placés dans un conduit de câbles ou doivent être attachés. Faute de quoi, le balotement ou le déplacement des câbles pourrait endommager le module ou les câbles et être à l'origine de dysfonctionnements par mauvais contact.
 - Utiliser des câbles homologués UL dans les catégories "CYJV" et "PVVA" avec la tension, le courant et la température nominaux appropriés (plage de température de fonctionnement des câbles : 75°C ou plus) pour l'installation du système.
 - Ne pas entremêler les lignes de commandes ou câbles de communication avec les lignes des circuits principaux ou les câbles d'alimentation. Les installer en maintenant entre eux une distance minimum de 100mm. Faute de quoi, il y a risque de dysfonctionnement par un bruit.
 - Pour débrancher le câble du module, ne pas tirer sur la câble proprement dit. Si le câble a un connecteur, saisir le câble par le connecteur. Tout effort de traction sur un câble raccorder au module peut être à l'origine de dysfonctionnements ou peut endommager le module ou le câble.
 - Une surintensité produite par une erreur dans un dispositif externe ou suite à une panne d'automate programmable peut si elle se prolonge être à l'origine d'un dégagement de fumée ou d'un départ de feu. Pour éviter cela, il faut configurer un circuit de sécurité, avec un fusible par exemple.
 - Le câblage et le remplacement de module doivent être effectués par un personnel de maintenance qualifié formé à la protection contre les chocs électriques. Quant aux méthodes de câblage, voir "INSTALLATION ET CABLAGE" dans le manuel de l'utilisateur.

[Précautions de mise en service et de maintenance]

- ▲ AVERTISSEMENT**
- Ne toucher à aucun connecteur quand l'appareil est sous tension. Il y aurait risque de choc électrique ou de dysfonctionnement.
 - Avant de nettoyer le module ou d'en resserrer les vis ou celles des connecteurs, couper l'alimentation électrique côté charge utilisée dans le système (sur toutes les phases). Faute de quoi, il y a risque de panne ou dysfonctionnement du module.

[Précautions de mise en service et de maintenance]

- ▲ ATTENTION**
- Ne pas démonter ni modifier le module. Cela pourrait entraîner des pannes ou dysfonctionnements et être à l'origine de blessures ou de départs de feu.
 - Ne pas faire tomber le module et ne pas le soumettre à des chocs. Cela risquerait d'endommager le module.
 - Avant de monter ou de retirer un module, couper l'alimentation électrique côté charge utilisée dans le système (sur toutes les phases). Faute de quoi, il y a risque de panne dysfonctionnement du module.
 - Après la première mise en service du produit, le nombre maximum admissible d'opérations de connexion/retrait des connecteurs est de 50 (selon CEI 61131-2/JIS B 3502). Dépasser la limite peut provoquer des dysfonctionnements.
 - Avant de manipuler le module où le câble à raccorder au module, se débarrasser de la charge électrostatique qu'accumule le corps humain en touchant un objet conducteur comme une barre de mise à la terre. Le non-respect de cette précaution peut être à l'origine de pannes ou de dysfonctionnements du module.
 - La mise en service et la maintenance des tableaux de commande doivent être effectués par un personnel de maintenance qualifié et formé à la protection contre les chocs électriques. Les tableaux de commande doivent être fermés à clef pour n'être accessibles qu'à un personnel de maintenance qualifié.

[Précautions de mise au rebut]

- ▲ ATTENTION**
- Lors de sa mise au rebut, ce produit doit être traité comme un déchet industriel.

[Précautions de transport]

- ▲ ATTENTION**
- Pour l'expédition, toujours utiliser l'emballage d'origine

WARRANTY

Please confirm the following product warranty details before using this product.

- Limited Warranty and Product Support.**
 - Mitsubishi Electric Company ("MELCO") warrants that for a period of eighteen (18) months after date of delivery from the point of manufacture or one year from date of Customer's purchase, whichever is less, Mitsubishi MELSEC Safety programmable logic controllers (the "Products") will be free from defects in material and workmanship.
 - At MELCO's option, for those Products MELCO determines are not as warranted, MELCO shall either replace them or issue a credit or return the purchase price paid for them.
 - For this warranty to apply:
 - Customer shall give MELCO (i) notice of a warranty claim to MELCO and the authorized dealer or distributor from whom the Products were purchased, (ii) the notice shall describe in reasonable details the warranty problem, (iii) the notice shall be provided promptly and in no event later than thirty (30) days after the Customer knows or has reason to believe that Products are not as warranted, and (iv) in any event, the notice must be given within the warranty period;
 - Customer shall cooperate with MELCO and MELCO's representatives in MELCO's investigation of the warranty claim, including preserving evidence of the claim and its causes, meaningfully responding to MELCO's questions and investigation of the problem, grant MELCO access to witnesses, personnel, documents, physical evidence and records concerning the warranty problem, and allow MELCO to examine and test the Products in question onsite or at the premises where they are installed or used; and
 - If MELCO requests, Customer shall remove Products it claims are defective and ship them to MELCO or MELCO's authorized representative for examination and, if found defective, for replacement. The costs of removal, shipment to and from MELCO's designated examination point, and reinstallation of replaced Products shall be at Customer's expense.
 - If Customer requests and MELCO agrees to effect Product replacements onsite at any domestic or overseas location, the Customer will pay for the costs of sending personnel and shipping Products. MELCO is not responsible for any re-commissioning, maintenance, or testing on-site that involves replacing of the Products.
- Limits of Warranties.**
 - MELCO does not warrant or guarantee the design, specify, manufacture, construction or installation of the materials, construction criteria, functionality, use, properties or other characteristics of the equipment, systems, or production lines into which the Products may be incorporated, including any safety, fail-safe and shut down systems using the Products.
 - MELCO is not responsible for determining the suitability of the Products for their intended purpose and use, including determining if the Products provide appropriate safety margins and redundancies for the applications, equipment or systems into which they are incorporated.
 - Customer acknowledges that qualified and experienced personnel are required to determine the suitability, application, design, construction and proper installation and integration of the Products. MELCO does not supply such personnel.

d. MELCO is not responsible for designing and conducting tests to determine that the Product functions appropriately and meets application standards and requirements as installed or incorporated into the end-user's equipment, production lines or systems.

e. MELCO does not warrant any Product:

- (1) altered by Customer;
- (2) subjected to negligence, carelessness, accident, misuse, or damage;
- (3) improperly stored, handled, installed or maintained;
- (4) integrated or used in connection with improperly designed, incompatible or defective hardware or software;
- (5) that fails because consumable parts such as batteries, backlights, or fuses were not tested, serviced or replaced;
- (6) operated or used with equipment, production lines or systems that do not meet applicable and commensurate legal, safety and industry-accepted standards;
- (7) operated or used in abnormal applications;
- (8) installed, operated or used in contravention of instructions, precautions or warnings contained in MELCO's user, instruction and/or safety manuals, technical bulletins and guidelines for the Products;
- (9) used with obsolete technologies or technologies not fully tested and widely accepted and in use at the time of the Product's manufacture;
- (10) subjected to excessive heat or moisture, abnormal voltages, shock, excessive vibration, physical damage or other improper environment; or
- (11) damaged or malfunctioning due to Acts of God, fires, acts of vandals, criminals or terrorists, communication or power failures, or any other cause or failure that results from circumstances beyond MELCO's control.

f. All Product information and specifications contained on MELCO's website and in catalogs, manuals, or technical information materials provided by MELCO are subject to change without prior notice.

g. The Product information and statements contained on MELCO's website and in catalogs, manuals, technical bulletins or other materials provided by MELCO are provided as a guide for Customer's use. They do not constitute warranties and are not incorporated in the contract of sale for the Products.

h. These terms and conditions constitute the entire agreement between Customer and MELCO with respect to warranties, remedies and damages and supersede any other understandings, whether written or oral, between the parties. Customer expressly acknowledges that any representations or statements made by MELCO or others concerning the Products outside these terms are not part of the basis of the bargain between the parties and are not factored into the pricing of the Products.

i. THE WARRANTIES AND REMEDIES SET FORTH IN THESE TERMS ARE THE EXCLUSIVE AND ONLY WARRANTIES AND REMEDIES THAT APPLY TO THE PRODUCTS.

j. MELCO DISCLAIMS THE IMPLIED WARRANTIES OF MERCHANTABILITY AND FITNESS FOR A PARTICULAR PURPOSE.

3. **Limits on Damages.**

a. MELCO'S MAXIMUM CUMULATIVE LIABILITY BASED ON ANY CLAIMS FOR BREACH OF WARRANTY OR CONTRACT, NEGLIGENCE, STRICT TORT LIABILITY OR OTHER THEORIES OF RECOVERY REGARDING THE SALE, REPLACEMENT, DELIVERY, PERFORMANCE, CONDITION, SUITABILITY, COMPLIANCE, OR OTHER ASPECTS OF THE PRODUCTS OR THEIR SALE, INSTALLATION OR USE SHALL BE LIMITED TO THE PRICE PAID FOR PRODUCTS NOT AS WARRANTED.

b. Although MELCO has obtained the certification for Product's compliance to the international safety standards IEC61508 and EN954-1/ISO13849-1 from TÜV Rheinland, this fact does not guarantee that Product will be free from any malfunction or failure. The user of this Product shall comply with any and all applicable safety standard, regulation or law and take appropriate safety measures for the system in which the Product is installed or used and shall take the second or third safety measures other than the Product. MELCO is not liable for damages that could have been prevented by compliance with any applicable safety standard, regulation or law.

c. MELCO prohibits the use of Products with or in any application involving power plants, trains, railway systems, airplanes, airline operations, other transportation systems, amusement equipments, hospitals, medical care, dialysis and life support facilities or equipment, incineration and fuel devices, handling of nuclear or hazardous materials or chemicals, mining and drilling, and other applications where the level of risk to human life, health or property are elevated.

d. MELCO SHALL NOT BE LIABLE FOR SPECIAL, INCIDENTAL, CONSEQUENTIAL, INDIRECT OR PUNITIVE DAMAGES, FOR LOSS OF PROFITS, SALES, OR REVENUE, FOR INCREASED LABOR OR OVERHEAD COSTS, FOR DOWNTIME OR LOSS OF PRODUCTION, FOR COST OVERRUNS, OR FOR ENVIRONMENTAL OR POLLUTION DAMAGES OR CLEAN-UP COSTS, WHETHER THE LOSS IS BASED ON CLAIMS FOR BREACH OF CONTRACT OR WARRANTY, VIOLATION OF STATUTE, NEGLIGENCE OR OTHER TORT, STRICT LIABILITY OR OTHERWISE.

e. In the event that any damages which are asserted against MELCO arising out of or relating to the Products or defects in them, consist of personal injury, wrongful death and/or physical property damages as well as damages of a pecuniary nature, the disclaimers and limitations contained in these terms shall apply to all three types of damages to the fullest extent permitted by law. If, however, the personal injury, wrongful death and/or physical property damages cannot be disclaimed or limited by law or public policy to the extent provided by these terms, then in any such event the disclaimer of and limitations on pecuniary or economic consequential and incidental damages shall nevertheless be enforceable to the fullest extent allowed by law.

f. In no event shall any cause of action arising out of breach of warranty or otherwise concerning the Products be brought by Customer more than one year after the cause of action accrues.

g. Each of the limitations on remedies and damages set forth in these terms is separate and independently enforceable, notwithstanding the unenforceability or failure of essential purpose of any warranty, undertaking, damage limitation, other provision of these terms or other terms comprising the contract of sale between Customer and MELCO.

4. Repair and Analysis

Please note that repairs and failure analysis are refused due to the structure of this product.

5. Discontinuation of Production

- Discontinuation of production shall be notified with Mitsubishi Technical Bulletins, etc.
- Product supply (including repair parts) is not available after production is discontinued.

6. Overseas Service

Overseas, please contact Mitsubishi's local overseas FA Center.

7. Delivery/Force Majeure.

- Any delivery date for the Products acknowledged by MELCO is an estimated and not a promised date. MELCO will make all reasonable efforts to meet the delivery schedule set forth in Customer's order or the purchase contract but shall not be liable for failure to do so.
- Products stored at the request of Customer or because Customer refuses or delays shipment shall be at the risk and expense of Customer.
- MELCO shall not be liable for any damage to or loss of the Products or any delay in or failure to deliver, service, or replace the Products arising from shortage of raw materials, failure of suppliers to make timely delivery, labor difficulties of any kind, earthquake, fire, windstorm, flood, theft, criminal or terrorist acts, war, embargoes, governmental acts or rulings, loss or damage or delays in carriage, acts of God, vandals or any other circumstances reasonably beyond MELCO's control.

8. Choice of Law/Jurisdiction.

These terms and any agreement or contract between Customer and MELCO shall be governed by the laws of the State of New York without regard to conflicts of laws. To the extent any action or dispute is not arbitrated, the parties consent to the exclusive jurisdiction and venue of the federal and state courts located in the Southern District of the State of New York. Any judgment there obtained may be enforced in any court of competent jurisdiction.

9. Arbitration.

Any controversy or claim arising out of, or relating to or in connection with the Products, their sale or use or these terms, shall be settled by arbitration conducted in accordance with the Center for Public Resources (CPR) Rules for Non-Administered Arbitration of International Disputes, by a sole arbitrator chosen from the CPR's panels of distinguished neutrals. Judgment upon the award rendered by the Arbitrator shall be final and binding and may be entered by any court having jurisdiction thereof. The place of the arbitration shall be New York City, New York. The language of the arbitration shall be English. The neutral organization designated to perform the functions specified in Rule 6 and Rules 7.7(b), 7.8 and 7.9 shall be the CPR.

ORIGINAL INSTRUCTION

Machinery Directive (2006/42/EC) Compliance

This product is suitable for establishing safety functions for general industrial machinery and complies with the Machinery Directive (2006/42/EC).

Before using this product, please read this manual, the relevant manuals, and the safety standards carefully and pay full attention to safety to handle the product correctly.

8. Safety Standards

Use the product according to the following safety standards.

Region	Safety standards
International	IEC 61508: 2010, IEC 62061: 2012, ISO 13849-1 IEC 61131-2 IEC 61000-6-2, IEC 61000-6-4 IEC 61784-3 IEC 60204-1 IEC 61326-3-1
Europe	EN ISO 13849-1 EN 61131-2 EN 61000-6-2, EN 61000-6-4
North America	UL 61010-1, UL 61010-2-201

Normes de sécurité

Observer les normes de sécurité suivantes.

Région	Norme
Global	IEC 61508: 2010, IEC 62061: 2012, ISO 13849-1 IEC 61131-2 IEC 61000-6-2, IEC 61000-6-4 IEC 61784-3 IEC 60204-1 IEC 61326-3-1
Europe	EN ISO 13849-1 EN 61131-2 EN 61000-6-2, EN 61000-6-4
Amérique du Nord	UL 61010-1, UL 61010-2-201

9. Safety Parameters

For details on the safety parameters of this product, refer to the CC-Link IE Field Network Waterproof/Dustproof Remote I/O Module (With Safety Functions) User's Manual.

10. Installation

When installing this product to a control panel, fully consider its operability, maintainability, and environmental resistance. For details, refer to the MELSEC iQ-R Module Configuration Manual and the CC-Link IE Field Network Waterproof/Dustproof Remote I/O Module (With Safety Functions) User's Manual.

Installing the module

When installing the safety remote I/O module, provide a clearance between the module and the sides of neighboring structures or parts to ensure good ventilation, avoid interference, and avoid stress on waterproof connectors. To insert or remove a communication connector, provide a clearance sufficient to use a screwdriver.

When using a right-angle, waterproof connector or a Y branch connector, provide a clearance to avoid stress on cables.

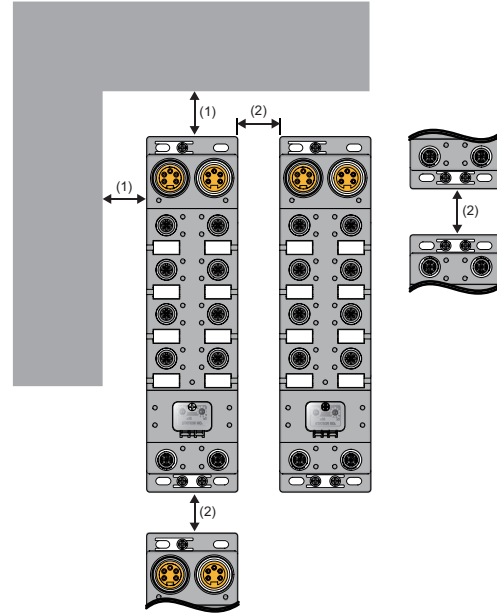

- (1) 0mm or longer
- (2) 50mm or longer

Installation orientations

The safety remote I/O module can be installed in six directions. Fix the module with screws.

Installation precautions

- Install the safety remote I/O module on the flat surface. When the installation surface is uneven, excessive force is applied to the printed-circuit board and may cause a defect.
- Do not install the safety remote I/O module to the place where:
 - Ambient temperature is outside the range of 0 to 55°C;
 - IP67 is not satisfied;
 - Condensation occurs due to rapid temperature change;
 - Corrosive gas or combustible gas is present;

- Conductive powder such as iron powder, oil mist, salinity, or organic solvent is filled;
- The safety remote I/O module is exposed to direct sunlight;
- A strong electric field or strong magnetic field is generated; and
- The safety remote I/O module is subject to vibration and shock.

11. Module Status After Power-on and LED Indication

No.	Name	Application
(1)	PW LED	Indicates the voltage status of the module power supply. On (green): The module power supply has no voltage error. On (red): The module power supply has a voltage error. Off: The module power supply is off or has a voltage error.
(2)	L PW LED	Indicates the voltage status of the load power supply. On (green): The load power supply has no voltage error. On (red): The load power supply has a voltage error. Off: The load power supply is off or has a voltage error.
(3)	I/O LED	Indicates the on/off state of I/Os. On (green): I/O signal is on. On (red): An I/O circuit error or double wiring discrepancy was detected. Flashing (red): An error occurred at one terminal of double wiring, or an error common to all I/O circuits except the terminal flashing red occurred. Off: I/O signal is off.
(4)	SAFETY LED	Indicates the safety communication status of the safety remote I/O module. On: Safety communication is established. Off: Safety communication is not established.
(5)	RUN LED	Indicates the operating status of the safety remote I/O module. On: Operating normally. Off: A major error occurred.
(6)	MODE LED	Indicates the mode of the safety remote I/O module. On: The unit test is completed. (online) Flashing: In unit test mode Off: Error occurred, Offline
(7)	ERR. LED	Indicates the error status of the safety remote I/O module. On: A module error occurred. Flashing: A minor error occurred. Off: Operating normally.
(8)	D LINK LED	Indicates the data link status of the safety remote I/O module. On: Communications are normal. Flashing: Communications are interrupted. Off: Disconnected
(9)	LER LED	Indicates the port status. On: Module received abnormal data, or module performing loopback. Off: Module received normal data, or module not performing loopback.
(10)	LINK LED ¹	Indicates the link status. On: Link-up in progress Off: Link-down in progress

¹ The LINK LED may be on at power-on, but this does not indicate an error.

12. Precautions for Use of Safety Programmable Controller

Users must prove that their entire safety system complies with the safety standards and the Machinery Directive. The third-party certification organization will validate the safety of product for the entire safety system, including a safety programmable controller and safety components.

To establish a safety system, calculate the target failure measure (PFDavg/PFH) for each safety application (safety function) based on the PFDavg/PFH values of the safety programmable controller and connected safety components. The target failure measure (PFDavg/PFH) is the reliability target value for each Safety Integrity Level (SIL) defined in IEC 61508 and can be calculated by the following formula. PFDavg/PFH = A + B + C + D.....Calculation formula of PFDavg/PFH

Variable	Definition
A	Total PFDavg/PFH of the safety CPU module, power supply module, base unit, and CC-Link IE Field Network master module
B	PFDavg/PFH of the CC-Link IE Field Network remote I/O module (with safety functions) (1) When safety input device(s) and safety output device(s) are connected to the same CC-Link IE Field Network remote I/O module (with safety functions): B = B1 (2) When safety input device(s) and safety output device(s) are connected to the different CC-Link IE Field Network remote I/O modules (with safety functions): B = B1 + B2
B1	PFDavg/PFH of the CC-Link IE Field Network remote I/O module (with safety functions) to which safety input device(s) is connected
B2	PFDavg/PFH of the CC-Link IE Field Network remote I/O module (with safety functions) to which safety output device(s) is connected
C ¹	PFDavg/PFH of safety input device(s)
D ¹	PFDavg/PFH of safety output device(s)

¹ For the values of PFDavg/PFH, refer to the manual for the safety component used.

The following table lists the PFDavg/PFH of each safety remote I/O module.

Module	PFDavg ²	PFH ²
NZ2GFS12A2-14DT	4.07×10 ⁻⁴	4.69×10 ⁻⁹

² Proof test interval is 20 years (module exchange interval).

13. EU Declaration of Conformity



EU DECLARATION OF CONFORMITY

We, Manufacturer : MITSUBISHI ELECTRIC CORPORATION
Address : TOKYO 100-8310, JAPAN
(Place of Declare)

Brand Name : MITSUBISHI ELECTRIC

declare under our sole responsibility that the product
Description : Programmable Controller
Type of Model : Remote I/O modules
Notice : Refer to next page about each type name

to which this declaration relates is in conformity with the following standard and directive.

Directive	Harmonized Standard	Notified Body
EMC Directive	2014/30/EU EN61131-2:2007	-
Machinery Directive	2006/42/EC EN ISO 13849-1 : 2015	1
RoHS Directive	2011/65/EU *1 EN 50581 : 2012, EN 62321 : 2009	-

*1 : Category 9 "Industrial monitoring and control instruments" is applicable.

This declaration is based on the conformity assessment of following Notified Body			
No.	Name and Address	Certificate Reg.No	Test Report No.
1	TÜV RHEINLAND INDUSTRIE SERVICE GMBH, Alboinstr. 56, 12103 Berlin, Germany	01/205/5699.00/19	968/M 419.04/19

Authorized representative in Europe
Hartmut Putz
FA product Marketing, Director, MITSUBISHI ELECTRIC EUROPE B.V., German Branch
Mitsubishi-Electric-Platz 1, 40882 Ratingen, Germany

The person authorized to compile the Technical file or relevant Technical documentation
Eric Gory
Product Manager, Woodhead Software and Electronic, Molex Transportation and Industrial Division, Zone d'Activité du Thuit Anger, 185 H Voie Romaine, 27370 LE THUIT DE LOISON – France

Issue Date (Date of Declaration): 31 January 2019

Signed for and on behalf of

(Signature) Hiroshi Ishida
[Hiroshi Ishida]
Senior Manager, FA Remote I/O Module Development Section
FA Systems Dept. 1
MITSUBISHI ELECTRIC CORPORATION NAGOYA WORKS

Appendix List of type name to declare

NZ2GFS12A2-16DTE
NZ2GFS12A2-14DT