



Numerical Protection Relay

MELPRO™-A Series

EARTH FAULT OVER VOLTAGE RELAY

MODEL

MVG-A1V-R, MVG-A1V-RD

INSTRUCTION MANUAL

Request

Ensure that this Instruction Manual is delivered to the end users and the maintenance manager.

— Safety section —

This Safety section should be read before starting any work on the relay.

Be sure to read the instruction manuals and other related documents prior to commencing any work on the relay in order to maintain them in a safe condition.

Be sure to be familiar with the knowledge, safety information and all caution items of the product prior to use.

 CAUTION	Caution means that failure to observe safety information, incorrect use, or improper use may endanger personnel and equipment and cause personnel injury or physical damage.
--	--

Items as classified to the caution may become to occur more sever results according to the circumstance. Therefore, all items described in the safety section are important and to be respected without fail.

CAUTION

1. Items concerning transportation
 - (1) Be sure the equipment to be kept in normal direction
 - (2) Avoid the bumps, shock, and vibration, otherwise the product performance /life might be unfavorably affected.
2. Items concerning storage
 - (1) Environment shall be below, otherwise the product performance/life might be unfavorably affected.
 - Ambient temperature: -20°C~+60°C (with no condensation nor freezing)
 - Relative humidity: 30~80% average of a day
 - Altitude: Less than 2000m
 - Avoid applying unusual shock, vibration or leaning or magnetic field
 - Not expose to harmful smoke, gas, salty air, water, vapor, dust, powder, explosive material or wind, rain.

3. Items concerning mounting/wiring work
 - (1) Mounting and wiring work should be done correctly.
Otherwise, damage, burning or erroneous operation might occur.
 - (2) Screw terminal should be tightened securely.
Otherwise, damage and burning might occur.

Tightened torque of screw shall be as below table

Material	Size	Standard torque	Permissible range	Application
Steel	M3.5	1.10N · m (11.2kgf · cm)	0.932~1.27N · m (9.5~12.9kgf · cm)	Terminals of back side
Brass	M4	0.961N · m (9.8kgf · cm)	0.824~1.11N · m (8.4~11.3kgf · cm)	Type MZT Secondary terminal(k,ℓ)

- (3) Grounding should be as done correctly in case it is required.
Otherwise, electric shock, damage, burning or erroneous operation might occur.
- (4) Wiring should be done without mistake especially observing the correct polarity.
Otherwise, damage, burning or erroneous operation might occur.
- (5) Wiring should be done without mistake especially observing the phase ordering.
Otherwise, damage, or erroneous operation might occur.
- (6) Auxiliary power source, measuring transformer and power source which have enough capacity for correct operation of product should be used.
Otherwise, an erroneous operation might occur.
- (7) Be sure to restore the front cover, terminal cover, protection cover, etc to the original position, which have been removed during the mounting/ wiring work.
Otherwise, electrical shock might occur at the time of checking.
- (8) Connection should be done correctly using designated and right connectors.
Otherwise, damage or burning might occur.
4. Concerning equipment operation and settings
 - (1) Operational condition should be as below.
Otherwise, the product performance/life might be unfavorably affected.
 - Deviation of auxiliary power: within +10%~-15% of rated voltage
 - Deviation of frequency: within ±5% of rated frequency
 - Ambient temperature: 0°C~+40°C (-20°C~+50°C is permissible during couples of hour per day, with no

condensation nor freezing)

-Relative humidity: 30~80% average of a day

-Altitude: Less than 2000m

-Avoid to be exposed to unusual shock, vibration, leaning or magnetic field

-Not expose to harmful smoke, gas, salty air, water, vapor, dust, powder, explosive material, wind or rain.

- (2) Qualified personnel may work on or operate this product, otherwise, the product performance/life might be unfavorably affected and/or burning or erroneous operation might occur.
 - (3) Be sure to read and understand the instruction manuals and other related documents prior to commencing operation and maintenance work on the product. Otherwise, electrical shock, injury, damage, or erroneous operation might occur.
 - (4) While energizing product, be sure not to remove any unit or parts without permissible one. Otherwise, damage, or erroneous operation might occur.
 - (5) While energizing product, be sure to make short circuit of current transformer secondary circuits before setting change or drawing out the sub unit. Otherwise, secondary circuit of live current transformer might be opened and damage or burning might occur due to the high level voltage.
 - (6) While energizing product, be sure to open trip lock terminal before setting change or drawing out the internal unit of product. Otherwise, erroneous operation might occur.
 - (7) Be sure to use the product within rated voltage and current.
Otherwise, damage or erroneous might occur.
5. Items concerning maintenance and checking
- (1) Be sure that only qualified personnel might work on or operate this product.
Otherwise, electrical shock, injury, damage, or erroneous operation might occur.
 - (2) Be sure to read and understand the instruction manuals and other related documents prior to commencing operation and maintenance work on the product. Otherwise, electrical shock, injury, damage, or erroneous operation might occur.
 - (3) In case of replacing the parts, be sure to use the ones of same type, rating and specifications, etc.
If impossible to use above parts, be sure to contact the sales office or distributor nearest you.
Otherwise, damage or burning might occur.
 - (4) Testing shall be done with the following conditions.
 - Ambient temperature: $20^{\circ}\text{C}\pm 10^{\circ}\text{C}$
 - Relative humidity: Less than 90%
 - Magnetic field: Less than 80A/m
 - Atmospheric pressure: $86\sim 106\times 10^3$ Pa
 - Installation angle: Normal direction $\pm 2^{\circ}$
 - Deviation of frequency: within $\pm 1\%$ of nominal frequency
 - Wave form(in case of AC): Distortion factor less than 2%
(Distortion factor= $100\%\times$ effective value of harmonics/effective value of fundamental)
 - Ripple (in case of DC): Ripple factor less than 3%
(Ripple factor= $100\%\times(\text{max}-\text{min})/\text{average of DC}$)
 - (5) Deviation of auxiliary power: within $\pm 2\%$ of nominal voltage
 - (6) Be sure not to inject the voltage or current beyond the overload immunity.
Otherwise, damage or burning might occur.
 - (7) Be careful not to touch the energized parts.
Otherwise, the electric shock might occur.
 - (8) While energizing product, be sure not to clean up the product . Only wiping a stain on the front cover of product with a damp waste might be allowable. (Be sure to wring hardly the water out of the waste.)
6. Items concerning modification and/or repair work
- Be sure to ask any modification and/ or repair work for product to the sales office or distributor nearest you.
Unless otherwise, any incidents occurred with modification or repair works (including software) done by any other entity than MITSUBISHI ELECTRIC CORPORATION shall be out of scope on warranty covered by MITSUBISHI ELECTRIC CORPORATION.
7. Items concerning disposal
- Particular regulations within the country of operation shall be applied to the disposal.

— Guarantee —

1. Guarantee period
The guarantee period of this product should be one year after delivery, unless otherwise specified by both parties.
2. Scope of guarantee
When any fault or defect is detected during the period of guarantee and such fault or defect is proved to be caused apparently at the responsibility of MITSUBISHI ELECTRIC CORPORATION, the defective unit concerned will be repaired or replaced by a substitute with free of charge. However, the fee for our engineer dispatching to site has to be covered by the user. Also, site retesting or trial operation caused along with replacing the defect units should be out of scope of our responsibilities. It is to be acknowledged that the following faults and defects should be out of this guarantee.
 - ① When the faults or defects are resulted from the use of the equipment at the range exceeding the condition/environment requirements stated in the catalogue and manual.
 - ② When the faults or defects are resulted from the reason concerning without our products.
 - ③ When the faults or defects are resulted from the modification or repair carried out by any other entity than MITSUBISHI ELECTRIC CORPORATION.
 - ④ When the faults or defects are resulted from a phenomenon which can not be predicted with the science and technology put into practical use at the time of purchase or contract.
 - ⑤ In case of integrating our products into your equipment, when damages can be hedged by the proper function or structure in the possession of your equipment which should be completed according to the concept of the de fact standard of industry.
 - ⑥ In case of that the faults or defects are resulted from un-proper application being out of instruction of MITSUBISHI ELECTRIC CORPORATION.
 - ⑦ In case that the faults or defects are resulted from force majeure such a fire or abnormal voltage and as an act of God such as natural calamity or disaster.
3. Exclusion of loss in opportunity and secondary loss from warranty liability
Regardless of the gratis warranty term, MITSUBISHI ELECTRIC CORPORATION shall not be liable for compensation of damages caused by any cause found not be the responsibility of MITSUBISHI ELECTRIC CORPORATION, loss in opportunity, lost profits incurred to the user by failures of MITSUBISHI ELECTRIC CORPORATION products, special damages and secondary damages whether foreseeable or not, compensation for accidents, and compensation for damages to products other than MITSUBISHI ELECTRIC CORPORATION products and other tasks
4. Applications of products
 - ①The user is requested to confirm the standards, the regulations and the restrictions which should be applied, in case of utilizing products described in this catalogue and another one in combination.
Also, the user is requested to confirm the suitability of our products to your applied system or equipment or apparatus by yourself. MITSUBISHI ELECTRIC CORPORATION shall not be liable for any suitability of our products to your utilization.
 - ②This MITSUBISHI ELECTRIC CORPORATION products described in the catalogue have been designed and manufactured for application in general industries, etc. Thus, application in which the life or an asset could be affected, such as medical system for life-sustaining, in nuclear power plants, power plants, aerospace, and transportation devices(automobile, train, ship, etc)shall be excluded from the application. In addition to above, application in which the life or an asset could be affected by potentially chemical contamination or electrical interference and also in which the circumstances and condition are not mentioned in this catalogue shall be excluded.Note even if the user wants to use for these applications with user's responsibility, the user to be requested to approve the specification of MITSUBISHI ELECTRIC CORPORATION products and to contact to the technical section of MITSUBISHI ELECTRIC CORPORATION prior to such applications. If the user applies MITSUBISHI ELECTRIC CORPORATION products to such applications without any contact to our technical section, MITSUBISHI ELECTRIC CORPORATION shall not be liable for any items and not be insured, independently from mentioned in this clause.
 - ③In using MITSUBISHI ELECTRIC CORPORATION product, the working conditions shall be that the application will not lead to a major accident even if any problem or fault occur, and that backup or duplicate system built in externally which should be decided depend on the importance of facility, are recommended.
 - ④The application examples given in this catalogue are reference only and you are requested to confirm function and precaution for equipment and apparatus and then, use our products
 - ⑤The user is requested to understand and to respect completely all warning and caution items so that unexpected damages of the user or the third party arising out of un-correct application of our products would not be resulted.
5. Onerous repair term after discontinuation of product
 - ①MITSUBISHI ELECTRIC CORPORATION shall accept onerous product repairs for 7(seven) years after production is terminated. (However, please consider the replacement of products being in operation during 15 years from ex-work.)
 - ②Product supply (including repair parts) is not available after production is discontinued.
6. Changes in product specification
The specification given in the catalogue, manuals or technical documents are subject to change without prior to notice.
7. Scope of service
The technical service fee such as engineer dispatching fee is excluded in the price of our products. Please contact to our agents if you have such a requirement.

MVG-A1 Series Ground Over Voltage Relay [Standard: JEC 2511]

Feature

1. A digital type relay corresponding ZVT, which has high accuracy and stable operating characteristic.
2. High sensitivity detection (2% detection) and wide setting range.
3. High reliability by the self-monitoring function.
The relay monitors control circuit, electric circuit and program data at all time, which are indicated by the (LED "RUN" lights up in the normal condition and goes out in the abnormal condition.)
4. Enriched measurement and display functions.
It is available to measure the input value of voltage and display the pick-up and setting values.
5. Forced operating is available by a test button.
6. Not need outside auxiliary power supply.
The auxiliary power supply can be supplied by VT secondary.
7. High vibration and impulse resisting performance.

Rating and Specifications

Type Name		MVG-A1V-R	MVG-A1V-RD											
Style No.		096PGA	515PGA											
Element	Protection	Ground over voltage element × 1												
	Measure	Voltage												
Ratings	Input voltage	7V (MPD-2 type or MPD-3 type ZVT secondary voltage)												
	Frequency	50/60Hz (Changeover)												
	Auxiliary power supply	AC100/110V (90~120V)												
Settings	Voltage	Vo (complete earth fault) = LOCK-2-4-6-8-10-12-14-16-18-20% {When 6.6KV complete earth fault 100% Vo primary voltage = 3810V, MPD type ZVT secondary output = 7V}												
	Time	Inst. (<60ms)-0.2-0.5-1.0-1.5-2.0-2.5-3.0-4.0-5.0 s												
	Using Condition	Frequency : 50Hz (SW1-ON) / 60Hz (SW1-OFF) changeover												
Display	Self monitoring	The LED "RUN" (green) lights up in normal condition.												
	Operation Display	The display target turns from black into orange color when relay operates. (Manual resetting type)												
	Numerical Display	<table border="1"> <thead> <tr> <th>SW No.</th> <th>Display function</th> </tr> </thead> <tbody> <tr> <td>0</td> <td>Input zero-phase voltage (%) : 1.0~25</td> </tr> <tr> <td>1</td> <td>Pickup display : U.</td> </tr> <tr> <td>2</td> <td>Zero-phase voltage settings (%) : 2.0~20</td> </tr> <tr> <td>3</td> <td>Operating time setting (s) : Inst., 0.2~5.0</td> </tr> <tr> <td>4</td> <td>Frequency setting (Hz) : 50/60</td> </tr> </tbody> </table>		SW No.	Display function	0	Input zero-phase voltage (%) : 1.0~25	1	Pickup display : U.	2	Zero-phase voltage settings (%) : 2.0~20	3	Operating time setting (s) : Inst., 0.2~5.0	4
SW No.	Display function													
0	Input zero-phase voltage (%) : 1.0~25													
1	Pickup display : U.													
2	Zero-phase voltage settings (%) : 2.0~20													
3	Operating time setting (s) : Inst., 0.2~5.0													
4	Frequency setting (Hz) : 50/60													
Test button		Forced operation is available in the condition of the rated voltage being applied. (The button should be depressed as long as the desired operation time lasts)												
Power Consumption VA (VT)		Normal : 4VA Operating : 7VA												
Case		Compact cylindrical fixed type	Compact cylindrical draw-out type											
Mass		Approx. 1.0k g	Approx. 1.1k g											

"LOCK" means that to let this element not to operate.

Characteristics

Item	Characteristics																						
Standard conditions of Use	Ambient temperature : -20~+50°C (in non-freezing state) Relative humidity : 30~80% Altitude : 2000m max. Other conditions : Not to be subject to abnormal vibration, shock or corrosive gases or excessive dust or moisture.																						
Characteristic control	Unit characteristic		Characteristic of combined with MPD																				
Operating value Characteristics	Within ±10% of setting value with setting of each operating value and minimum operating time.		Within ±25% of setting value with setting of each operating value and minimum operating time.																				
			V ₀ setting (%)	2	4	6	8	10															
			3-phase voltage (V)	76.2	152.4	229	305	381															
			T terminal voltage (V) (MPD-3 only)	7.62	15.24	22.9	30.5	38.1															
		V ₀ setting (%)	12	14	16	18	20																
		3-phase voltage (V)	457	533	610	686	762																
		T terminal voltage (V) (MPD-3 only)	45.7	53.3	61.0	68.6	76.2																
Reset value Characteristics	90% or more of operating value with setting of maximum operating value and maximum operating time.		Same as left																				
Operating time Characteristics	V ₀ setting=10% <table border="1" style="width: 100%; border-collapse: collapse;"> <tr> <td style="width: 50%; text-align: center;">Input voltage</td> <td style="width: 50%; text-align: center;">150% of setting value</td> </tr> <tr> <td style="text-align: center;">Time setting</td> <td style="text-align: center;">60ms or less</td> </tr> <tr> <td style="text-align: center;">Inst.</td> <td style="text-align: center;">±10% of setting value</td> </tr> <tr> <td style="text-align: center;">0.2~5s</td> <td></td> </tr> </table>		Input voltage	150% of setting value	Time setting	60ms or less	Inst.	±10% of setting value	0.2~5s		Same as left			Note) The operating time should be +15ms upon the left table when combined with MPD-1 or MPD-2.									
Input voltage	150% of setting value																						
Time setting	60ms or less																						
Inst.	±10% of setting value																						
0.2~5s																							
Reset time Characteristics	250ms±50ms Test condition: · Input : 150% of setting value → 0V · Setting : V ₀ =10%																						
Frequency Characteristics	Operating value: Within ±10% at the rated frequency. Operating time : Within ±10% at the rated frequency. Test condition: · Rated frequency: ±5% variation · Setting : V ₀ =10%, Operating time = 0.2s.																						
Variation characteristic of auxiliary power supply	Operating value: Within ±10% against the operating value of at the rated voltage. Operating time : Within ±10% against the operating value of at the rated voltage. Test condition: · Rated voltage : AC90V~120V · Setting : V ₀ =10%, Operating time = 0.2s.																						
Temperature Characteristics	Operation value : ±10% at 20°C Operating time : ±10% at 20°C Test condition: · Temperature : -20~60°C · Setting : V ₀ =10%, Operating time = 0.2s.																						
Vibration	<table border="1" style="width: 100%; border-collapse: collapse;"> <thead> <tr> <th rowspan="2" style="text-align: center;">Frequency (Hz)</th> <th colspan="3" style="text-align: center;">Peak-to-peak amplitude mm (acceleration m/s²)</th> <th rowspan="2" style="text-align: center;">Vibration times (s)</th> </tr> <tr> <th style="text-align: center;">Forward/backward</th> <th style="text-align: center;">Right/left</th> <th style="text-align: center;">Up/down</th> </tr> </thead> <tbody> <tr> <td style="text-align: center;">10</td> <td colspan="2" style="text-align: center;">5 (9.8)</td> <td style="text-align: center;">2.5 (4.9)</td> <td style="text-align: center;">30</td> </tr> <tr> <td style="text-align: center;">16.7</td> <td colspan="3" style="text-align: center;">0.4 (1.96)</td> <td style="text-align: center;">600</td> </tr> </tbody> </table>				Frequency (Hz)	Peak-to-peak amplitude mm (acceleration m/s ²)			Vibration times (s)	Forward/backward	Right/left	Up/down	10	5 (9.8)		2.5 (4.9)	30	16.7	0.4 (1.96)			600	When the above vibration is applied with setting of maximum operating value and minimum operating time and applied 90% input voltage (against setting value), it is not abnormal operation and wrong display.
Frequency (Hz)	Peak-to-peak amplitude mm (acceleration m/s ²)			Vibration times (s)																			
	Forward/backward	Right/left	Up/down																				
10	5 (9.8)		2.5 (4.9)	30																			
16.7	0.4 (1.96)			600																			
Shock	When apply a shock to the relay at the maximum acceleration of 294m/s ² 3 times with each forward and backward, right and left, and vertically, it is not abnormality.																						

Insulation Resistance	10MΩ or more between all the electric circuit and the case (E terminal) 10MΩ or more between independent electric circuits 10MΩ or more between contact circuit terminals (between poles) When tested at relative humidity of 80% RH max.	} DC500V megger used				
Voltage withstand	2000V AC, for 1 minute between all the electric circuits and the case (E terminal) 2000V AC, for 1 minute between independent electric circuits 1000V AC, for 1 minute between contact circuit terminals (between poles) a ₁₁ -a ₁₂ , a ₂₁ -a ₂₂					
Lightning impulse withstand voltage	Apply 1.2/50μs standard waveform to positive/negative electrodes for 3 times. It is not abnormality. <ul style="list-style-type: none"> • Between ZVT primary and the case (E terminal) : 60KV • Between all the electric circuits and the case (E terminal) : 4.5KV • Between ZVT secondary and control circuits : 4.5KV • Between independent electric circuits : 3KV • Between auxiliary power supply contacts : 3KV 					
Noise-proof	Apply IEC voltage waveform to the relay for 2 seconds with maximum voltage setting. It is not abnormality. <ul style="list-style-type: none"> • Between ZVTsecondary and ground (E terminal) • Between auxiliary power supply contacts and ground (E terminal) • Between auxiliary power supply contacts 					
Radio disturbance	No voltage input to the relay with maximum operating setting. At the same time to put a transceiver antenna (5W output) with 150MHz or 400MHz band closing the relay panel about 0.5m. It is not abnormal operation.					
Contact capacity	<table border="1" style="width: 100%; border-collapse: collapse;"> <tr> <td style="width: 33%; text-align: center; vertical-align: middle;">Closed circuit</td> <td style="width: 33%; padding: 5px;"> AC110V : 10A (Power factor = 0.5) DC220V : 10A DC110V : 15A (L/R=0s) </td> <td style="width: 33%; text-align: center; vertical-align: middle;">Opened circuit</td> <td style="width: 33%; padding: 5px;"> AC110V : 5A (Power factor = 0.5) AC220V : 1A (Power factor = 0.5) DC110V : 0.2A (L/R=40ms) </td> </tr> </table>		Closed circuit	AC110V : 10A (Power factor = 0.5) DC220V : 10A DC110V : 15A (L/R=0s)	Opened circuit	AC110V : 5A (Power factor = 0.5) AC220V : 1A (Power factor = 0.5) DC110V : 0.2A (L/R=40ms)
Closed circuit	AC110V : 10A (Power factor = 0.5) DC220V : 10A DC110V : 15A (L/R=0s)	Opened circuit	AC110V : 5A (Power factor = 0.5) AC220V : 1A (Power factor = 0.5) DC110V : 0.2A (L/R=40ms)			

Construction

RUN indicated LED (Green)

Continuously monitor the auxiliary power supply circuit, electric circuit, program date, etc., and the RUN LRD lights up in normal condition.

LED for numerical display

The following items can be displayed by switch setting.

- (1) Voltage measurement...
Input voltage can be displayed with range of 1.0 to 25%.
- (2) Pickup display...
Display the pickup with U.
- (3) Setting value display...
Each setting value can be displayed.

Switches for operating voltage and operating time setting

- Set the setting value
- To change the setting with hand or a small (-) screwdriver.

Display reset lever on the operation flag unit

Pushing reset lever makes it possible to reset the operation display unit. While the lever is being pushed up, the relay function is locked.

Note) Since the display plug of the operation display unit is of a very precise structure, avoid touching it directly by hand.

Selector switch for display selection

- Set the display item
- To change the setting with hand or a small (-) screwdriver.

Test switch

By pressing the TEST button, forced operating is available.

Frequency setting switch

The used frequency can be set with ON/OFF switch.

50Hz setting → ON OFF

60Hz setting → ON OFF

When the switch is set, do not use any tool with a sharp point. (It may cause damage to the switch lever.)

Operation flag indicator

During relay operating, this indicator changes from black to orange.

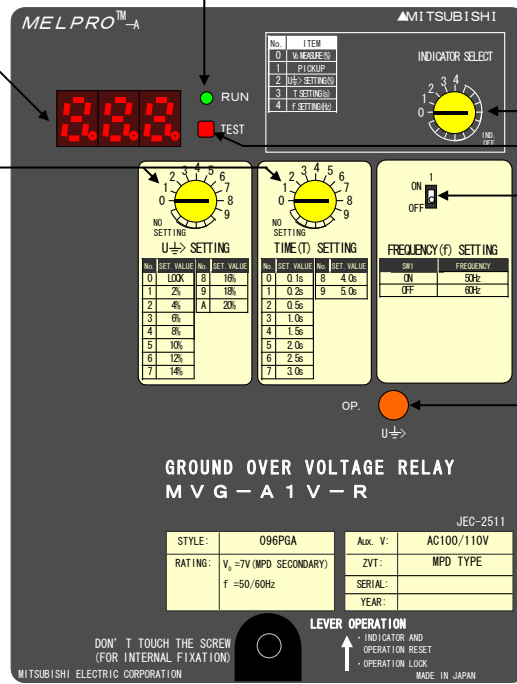
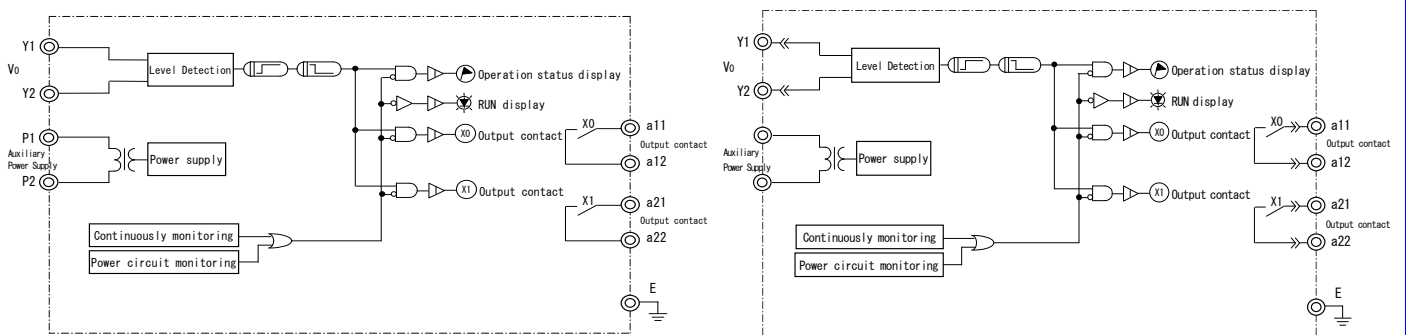

Fig. 6-1 MVG-A1 series construction (panel)

Internal Connection diagram



a) MVG-A1V-R

b) MVG-A1V-RD

Fig. 6-2 Internal Connection diagram

Operating Description

1. Relay function

- ① This relay has a built-in regulated voltage circuit which derives control voltage from the VT secondary voltage, therefore, particular auxiliary power supply is not required.
- ② The input zero-phase voltage is converted into a electronic circuit level signal by a built-in auxiliary VT.
- ③ The input zero-phase voltage signal is converted into a digital signal by A/D converter, and as data input microcomputer.
- ④ The microcomputer calculates and compares the level of the input zero-phase voltage signal data with the setting value data. If the zero-phase voltage signal is more than the setting value, the timer starts counting. If the counter is more than the operating time setting, the relay and the operating flag unit start to operate.

2. RUN display (Self-monitoring Function)

This relay monitors control voltage, electric circuit and program data at all time. The RUN LED (green) lights up in the normal condition, and goes out in the abnormal condition. Since control voltage is derived from VT secondary voltage input, the LED goes out when the auxiliary power supply voltage lower than approx. 85V.

3. Numerical Display Function

By changing the position of the selector switch, the following values can be displayed on the numerical display LED.

① Voltage measurement... (switch position : 0) ...

Based on the zero-phase voltage signal data, the zero-phase voltage is measured and computed, and then to display the input voltage value. The display range is from 1.0% to 25%. (When more than 25%, "O.F." is displayed.) Here, 100% = 3810V (when one phase is in complete earth fault condition at 6.6KV, and the MPD type ZVT secondary = 7V.)

② Pickup display... (switch position : 1) ...

When the input voltage is more than the setting value,

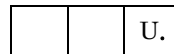

Using this function, easy test the operating value.

When pressing the TEST button (forced operation),

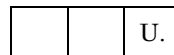

③ Setting value display... (Switch position : 2~4) ...

This function displays the relay setting condition including zero-phase voltage settings (V), operating time T Settings (s) and frequency setting value (Hz).

External Connection Diagram (Example)

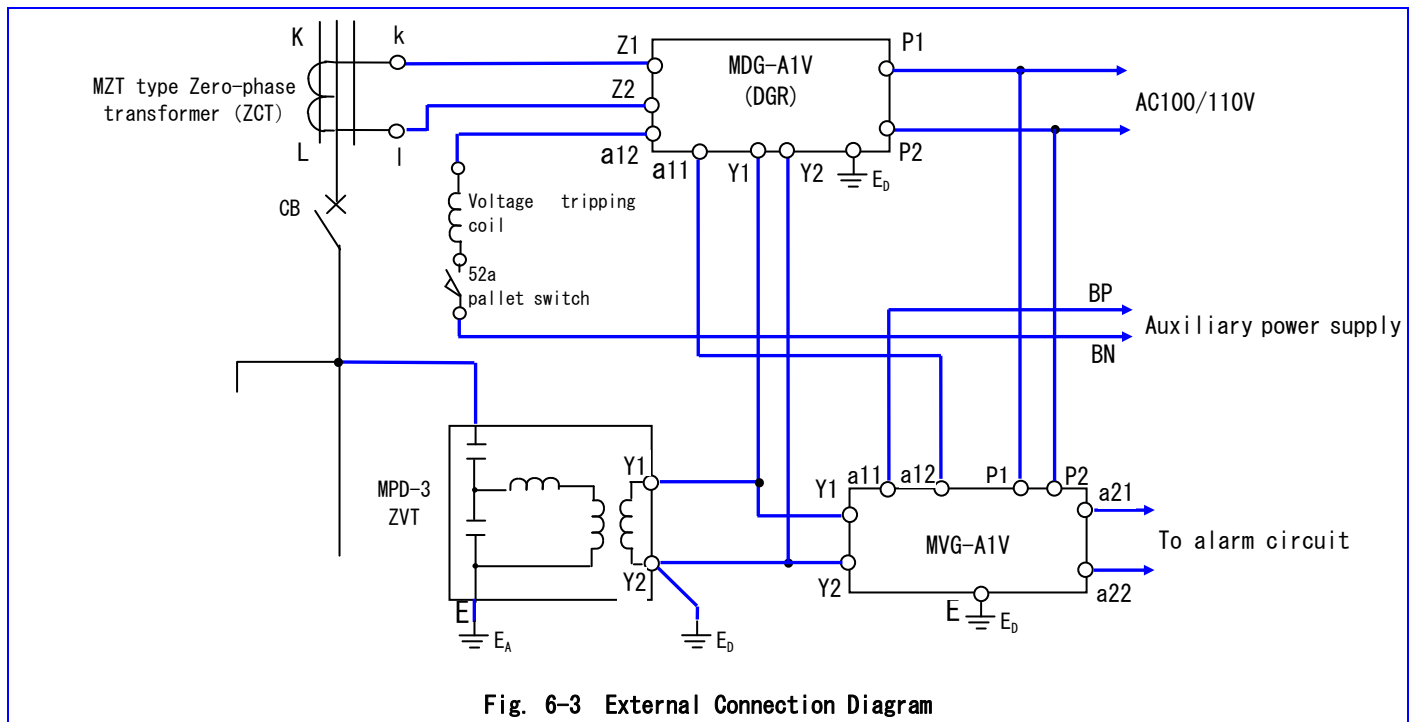

Fig. 6-3 External Connection Diagram

Note) For type MPD-2, provide DS or PCS on ZVT primary side please.

Handling Method

1. Panel assemble

① Do connect the relay terminal “E” to earth at Class D please.

② Type MVG-A1V-RD is a draw-out type that the sub-unit can be drawn out from case.

For detail, refer to section of “Drawing out and Housing operation of Sub-unit” please.

2. Use and Operation

① About the setting of frequency, it is set OFF at the time of shipment, so it is necessary to set the frequency switch again according to the using frequency when begin to use this relay.

Refer to the page 13, Cover Handling.

② Avoid changing the setting value during relay operating, since it is possible to occur unwanted operation. However, if the setting change is unavoidable, please push up the reset lever in order to lock relay operating.

③ To change the setting may be realized manually by the

setting switch. It is also possible by using a small minus (-) screwdriver. If a large minus (-) screwdriver is used, it may damage the groove of the switch knob.

④ The switch for setting is a rotary one utilizing snap action. When the setting is changed, turn the switch smoothly so as not to stop it in mid-position.

⑤ The position of the display selector switch is not specified in particular, but if it is normally set to 0|Vo Measure (%), The input voltage value can be measured conveniently.

⑥ Since the RUN indicator LED is lighting during the normal operation, check it in routine checking please. If it turns off, check the voltage value between terminals of P1-P2, and if it is still in OFF state even the input voltage is approx 85V or more, please contact our local agent and branch office since the relay may fail.

Test

A relay test is carried out sufficiently by maker before shipment. But at the following cases, it is recommended that the test be carried out again.

- a. After the products are unpacked when received
- b. When the equipment starts operation
(Power receiving starts)
- c. When periodical checkup is carried out
(Normally once per year)

1. Testing

① About the voltage input waveform, please use a sine wave without distortion.

② To select the switch for each setting with hand or use a small regular screwdriver (“—” type).

③ Set the selector switch position to 0|Vo Measure (%) as appropriate according to the test item. Set other switches for setting according to the test conditions of the operation characteristic control points.

④ If the operation characteristics are tested specially in individual control points (for example, when tested with the in-service setting conditions), the test should be performed with the operation characteristic points when the products are received, a receiving test

should be carried out with individual control point after judging the performance of this relay. Please use this data as a later standard.

2. Withstand Voltage Test

Perform the unit test as follows.

- a. Apply 2000V AC (commercial frequency) between all electric circuit and case (E terminal) for one minute, and make sure that no problem.

Voltage Applied Terminals	
<div style="display: flex; flex-wrap: wrap; justify-content: space-around;"> <div style="text-align: center;">(Y1) (P1) (a11) (a12)</div> <div style="text-align: center;">(Y2) (P2) (a21) (a22)</div> </div>	(E)

- b. Apply 2000V AC (commercial frequency) between all electric circuit and case (E terminal) for one minute, and make sure that no problem.

Voltage Applied Terminals	
(P1) (P2)	(a11) (a12) (a21) (a22)
(Y1) (Y2)	(a11) (a12) (a21) (a22)
(P1) (P2)	(Y1) (Y2)

3. Operation Characteristics Test

- ① Increase the control voltage gradually, the RUN indicator LED (green) will light up at approx. 70V. This indicates that the electronic circuit has started to operate normally.
- ② With the rated voltage and press the TEST button located relay panel, make sure that the forced operation is available please.
- ③ With the rated voltage and press the TEST button located relay panel, make sure that the forced operation is available please.

Test Item	Test Condition			Criterion	
	Input	Operation value	Operation time	Unit only	Combined with MPD
Operation value	—	Each setting	Minimum setting	±10% of setting value	±25% of setting value
Operation time	OV ↓ 150% of setting	10%	Inst.	60ms or less	Same as left (Note)
		10%	Other above	±10% of setting value	

4. Operation Characteristic Control Point

Perform the test periodically according to the following test condition and criterion.

Terminal Layout

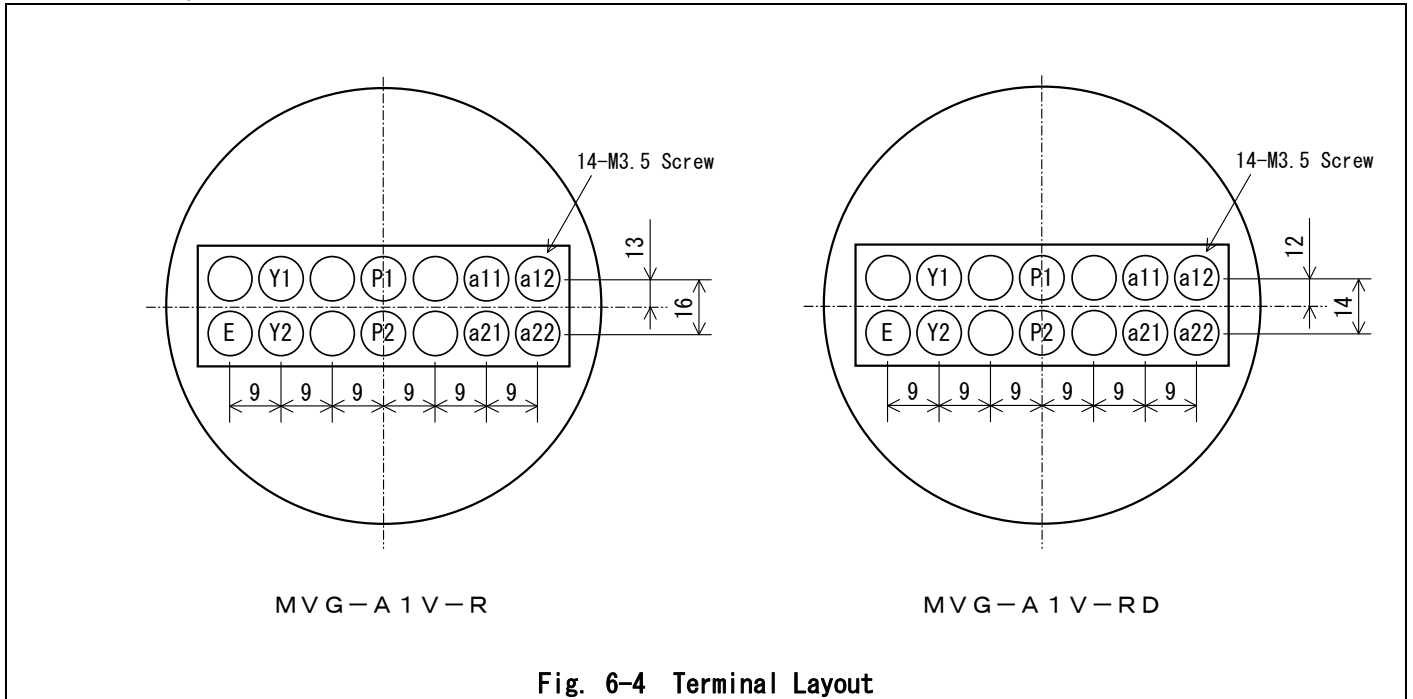

Fig. 6-4 Terminal Layout

Drawing out and Housing operation of Sub-unit

—For compact cylindrical draw-out type (RD type)

it is available to draw out the sub-unit from the relay case instead of removing the external wires. So that easier to carry out checking and testing.

When drawing out and housing, please pay attention to not to touch the electric circuit and move the sub-unit by handing the lever or form.

Otherwise, it is possible to get an electric shock or make internal electric parts damage.

The following operation should be checked when sub-unit be drawn out from relay case.

- Lock the tripping circuit
- Turn off the power supply into relay
- Disconnect CT circuit
- Disconnect VT circuit
- Opened the auxiliary power supply
(only the RD type relay)

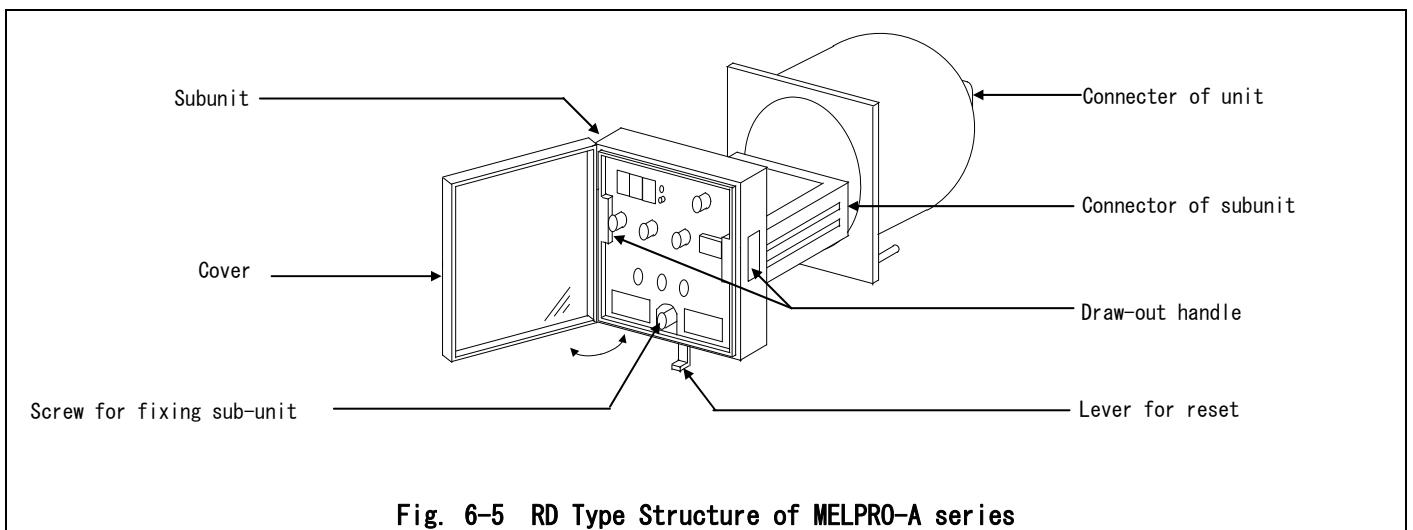
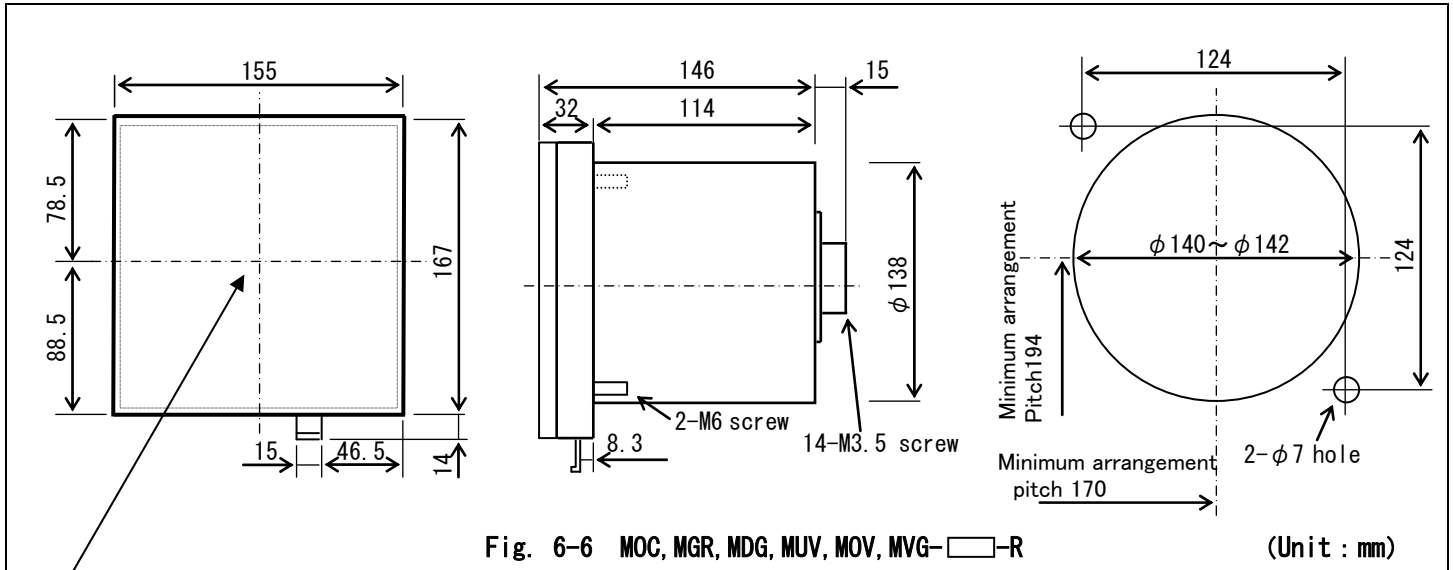
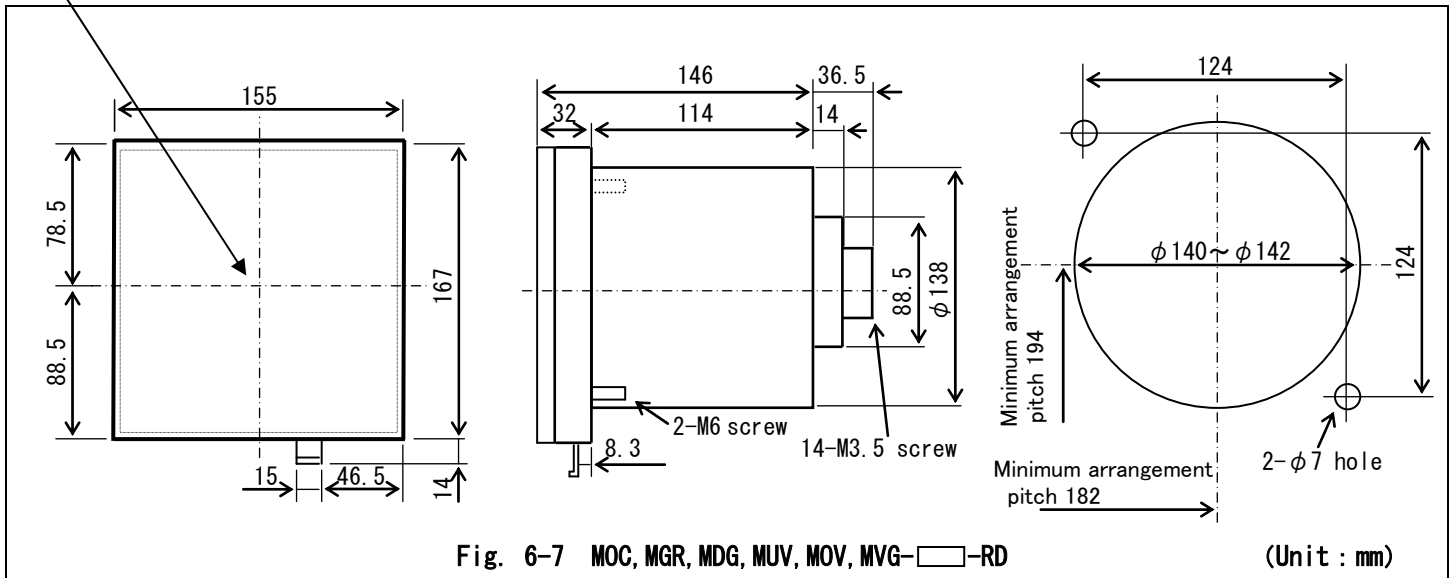

Fig. 6-5 RD Type Structure of MELPRO-A series

Monitoring and Dimensions



Same as the center lines of $\phi 140\sim 142$ hole



● Cover Handling

Relay cover is opening-and-closing door type. Once forces the cover overload when open it, it will be removed from case. Please refer to the figure shown blow to assemble the cover at horizontal direction. (Do not assemble it at the direction of the front.)

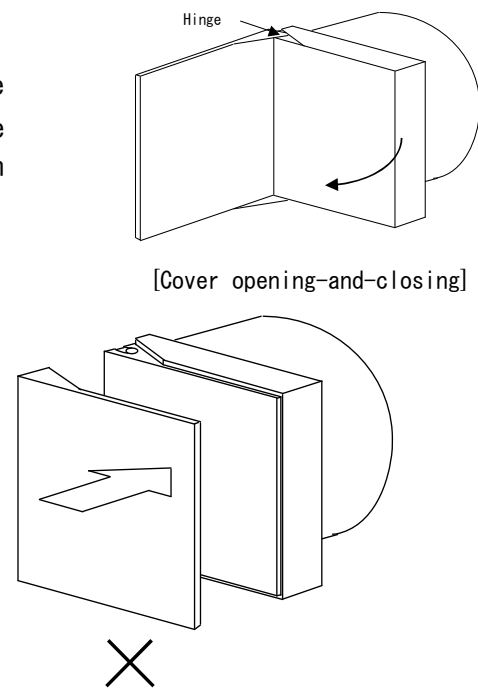
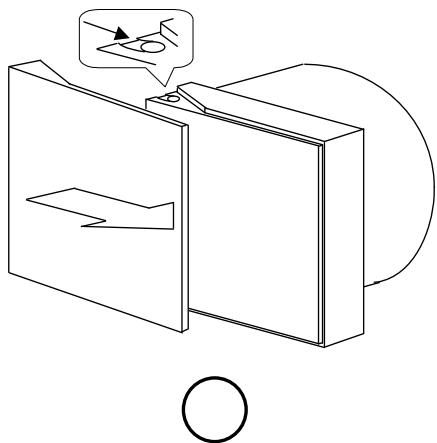

Improvement on the reliability of protection function

Any parts and materials applied to the protection relay have limited life time which will bring the degradation to the relay.

The degree of degradation will be variable and depend on the purpose, period in use, applied circumstance and unevenness on the performance of each part.

MITSUBISHI ELECTRIC CORPORATION design the relay so as to realize that the recommended replaced duration is more them 15 years.

However, there may be some possibilities to occur some defects before reaching 15 years due to above mentioned the degree of degradation of parts and materials being depended on the condition in use.

To prevent unwanted operation or no operation of relay due to above reasons, it is recommended to apply the relay with self-diagnosis function and/or multiplexing relay system such as dual or duplex scheme.

mitsubishi **MITSUBISHI ELECTRIC CORPORATION**

HEAD OFFICE : 7-3 MARUNOUCHI 2-CHOME, CHIYODA-KU TOKYO, 100-8310, JAPAN

Revised in Nov. 2011