



General-Purpose AC Servo

MITSUBISHI SERVO AMPLIFIERS & MOTORS

MELSERVo-J4

SSCNET III/H Interface Multi-axis AC Servo

MODEL

MR-J4W2- _ B

MR-J4W3- _ B

MR-J4W2-0303B6

SERVO AMPLIFIER INSTRUCTION MANUAL



● Safety Instructions ●

Please read the instructions carefully before using the equipment.

To use the equipment correctly, do not attempt to install, operate, maintain, or inspect the equipment until you have read through this Instruction Manual, Installation guide, and appended documents carefully. Do not use the equipment until you have a full knowledge of the equipment, safety information and instructions. In this Instruction Manual, the safety instruction levels are classified into "WARNING" and "CAUTION".



Indicates that incorrect handling may cause hazardous conditions, resulting in death or severe injury.



Indicates that incorrect handling may cause hazardous conditions, resulting in medium or slight injury to personnel or may cause physical damage.

Note that the CAUTION level may lead to a serious consequence according to conditions. Please follow the instructions of both levels because they are important to personnel safety. What must not be done and what must be done are indicated by the following diagrammatic symbols.



Indicates what must not be done. For example, "No Fire" is indicated by .



Indicates what must be done. For example, grounding is indicated by .

In this Instruction Manual, instructions at a lower level than the above, instructions for other functions, and so on are classified into "POINT".

After reading this Instruction Manual, keep it accessible to the operator.

1. To prevent electric shock, note the following

WARNING

- Before wiring and inspections, turn off the power and wait for 15 minutes or more until the charge lamp turns off. Then, confirm that the voltage between P+ and N- is safe with a voltage tester and others. Otherwise, an electric shock may occur. In addition, when confirming whether the charge lamp is off or not, always confirm it from the front of the servo amplifier.
- Ground the servo amplifier and servo motor securely.
- Any person who is involved in wiring and inspection should be fully competent to do the work.
- Do not attempt to wire the servo amplifier and servo motor until they have been installed. Otherwise, it may cause an electric shock.
- Do not operate switches with wet hands. Otherwise, it may cause an electric shock.
- The cables should not be damaged, stressed, loaded, or pinched. Otherwise, it may cause an electric shock.
- To prevent an electric shock, always connect the protective earth (PE) terminal (marked \oplus) of the servo amplifier to the protective earth (PE) of the cabinet.
- To avoid an electric shock, insulate the connections of the power supply terminals.

2. To prevent fire, note the following

CAUTION

- Install the servo amplifier, servo motor, and regenerative resistor on incombustible material. Installing them directly or close to combustibles will lead to smoke or a fire.
- Always connect a magnetic contactor between the power supply and the main circuit power supply (L1/L2/L3) of the servo amplifier, in order to configure a circuit that shuts down the power supply on the side of the servo amplifier's power supply. If a magnetic contactor is not connected, continuous flow of a large current may cause smoke or a fire when the servo amplifier malfunctions.
- Always connect a molded-case circuit breaker, or a fuse to each servo amplifier between the power supply and the main circuit power supply (L1/L2/L3) of the servo amplifier (including converter unit), in order to configure a circuit that shuts down the power supply on the side of the servo amplifier's power supply. If a molded-case circuit breaker or fuse is not connected, continuous flow of a large current may cause smoke or a fire when the servo amplifier malfunctions.
- When using the regenerative resistor, switch power off with the alarm signal. Otherwise, a regenerative transistor malfunction or the like may overheat the regenerative resistor, causing smoke or a fire.
- Provide adequate protection to prevent screws and other conductive matter, oil and other combustible matter from entering the servo amplifier and servo motor.

3. To prevent injury, note the following

CAUTION

- Only the power/signal specified in the Instruction Manual should be applied to each terminal. Otherwise, it may cause an electric shock, fire, injury, etc.
- Connect cables to the correct terminals. Otherwise, a burst, damage, etc., may occur.
- Ensure that polarity (+/-) is correct. Otherwise, a burst, damage, etc., may occur.
- The servo amplifier heat sink, regenerative resistor, servo motor, etc., may be hot while the power is on and for some time after power-off. Take safety measures such as providing covers to avoid accidentally touching them by hands and parts such as cables.

4. Additional instructions

The following instructions should also be fully noted. Incorrect handling may cause a malfunction, injury, electric shock, fire, etc.

(1) Transportation and installation

CAUTION

- Transport the products correctly according to their mass.
- Stacking in excess of the specified number of product packages is not allowed.
- Do not hold the cables or connectors when carrying the servo amplifier. Otherwise, it may drop.
- Install the servo amplifier and the servo motor in a load-bearing place in accordance with the Instruction Manual.
- Do not get on or put heavy load on the equipment. Otherwise, it may cause injury.
- The equipment must be installed in the specified direction.
- Maintain specified clearances between the servo amplifier and the inner surfaces of a control cabinet or other equipment.
- Do not install or operate the servo amplifier and servo motor which have been damaged or have any parts missing.
- Do not strike the connector. Otherwise, it may cause a connection failure, malfunction, etc.
- When you keep or use the equipment, please fulfill the following environment.

| Item | | Environment |
|----------------------|-----------|------------------------------------------------------------------------------------------------|
| Ambient temperature | Operation | 0 °C to 55 °C (non-freezing) |
| | Storage | -20 °C to 65 °C (non-freezing) |
| Ambient humidity | Operation | 5 %RH to 90 %RH (non-condensing) |
| | Storage | |
| Ambience | | Indoors (no direct sunlight), free from corrosive gas, flammable gas, oil mist, dust, and dirt |
| Altitude | | 2000 m or less above sea level (Contact your local sales office for the altitude for options.) |
| Vibration resistance | | 5.9 m/s ² , at 10 Hz to 55 Hz (X, Y, Z axes) |

- Do not block the intake and exhaust areas of the servo amplifier. Otherwise, it may cause a malfunction.
- Do not drop or apply heavy impact on the servo amplifiers and the servo motors. Otherwise, it may cause injury, malfunction, etc.
- When the product has been stored for an extended period of time, contact your local sales office.
- When handling the servo motor, be careful with the sharp edges of the servo motor.
- The servo amplifier must be installed in a metal cabinet.
- When fumigants that contain halogen materials, such as fluorine, chlorine, bromine, and iodine, are used for disinfecting and protecting wooden packaging from insects, they cause a malfunction when entering our products. Please take necessary precautions to ensure that remaining materials from fumigant do not enter our products, or treat packaging with methods other than fumigation, such as heat treatment. Additionally, disinfect and protect wood from insects before packing the products.
- To prevent a fire or injury in case of an earthquake or other natural disasters, securely install, mount, and wire the servo motor in accordance with the Instruction Manual.

(2) Wiring

⚠ CAUTION

- Wire the equipment correctly and securely. Otherwise, the servo motor may operate unexpectedly.
- Make sure to connect the cables and connectors by using the fixing screws and the locking mechanism. Otherwise, the cables and connectors may be disconnected during operation.
- Do not install a power capacitor, surge killer, or radio noise filter (optional FR-BIF) on the servo amplifier output side.
- To avoid a malfunction, connect the wires to the correct phase terminals (U/V/W) of the servo amplifier and servo motor.
- Connect the servo amplifier power output (U/V/W) to the servo motor power input (U/V/W) directly. Do not connect a magnetic contactor and others between them. Otherwise, it may cause a malfunction.

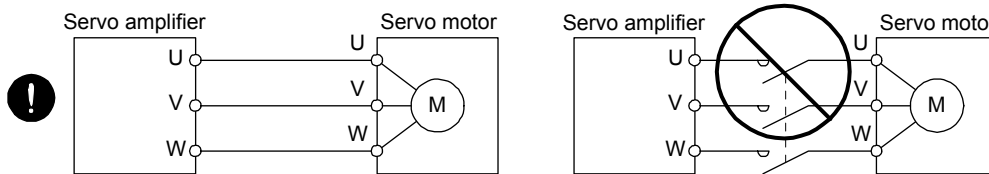

- The connection diagrams in this Instruction Manual are shown for sink interfaces, unless stated otherwise.
- The surge absorbing diode installed to the DC relay for control output should be fitted in the specified direction. Otherwise, the converter unit and the drive unit will malfunction and will not output signals, disabling the emergency stop and other protective circuits.

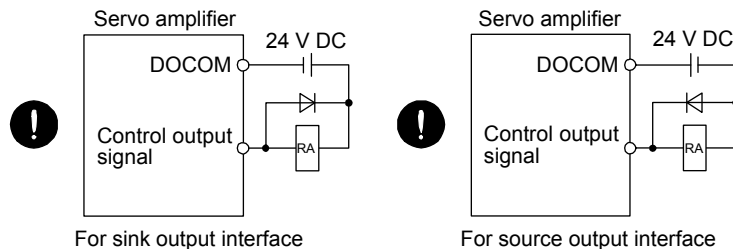

- When the wires are not tightened enough to the terminal block, the wires or terminal block may generate heat because of the poor contact. Be sure to tighten the wires with specified torque.
- Connecting an encoder of wrong axis to the CN2A, CN2B, or CN2C connector may cause a malfunction.
- Connecting a servo motor of the wrong axis to the CNP3A, CNP3B, or CN3C connector may cause a malfunction.
- Configure a circuit to turn off EM2 or EM1 when the main circuit power supply is turned off to prevent an unexpected restart of the servo amplifier.
- To prevent malfunction, avoid bundling power lines (input/output) and signal cables together or running them in parallel to each other. Separate the power lines from the signal cables.

(3) Test run and adjustment

CAUTION

- When executing a test run, follow the notice and procedures in this instruction manual. Otherwise, it may cause a malfunction, damage to the machine, or injury.
- Before operation, check and adjust the parameter settings. Improper settings may cause some machines to operate unexpectedly.
- Never make a drastic adjustment or change to the parameter values as doing so will make the operation unstable.
- Do not get close to moving parts during the servo-on status.

(4) Usage

CAUTION

- Provide an external emergency stop circuit to stop the operation and shut the power off immediately.
- For equipment in which the moving part of the machine may collide against the load side, install a limit switch or stopper to the end of the moving part. The machine may be damaged due to a collision.
- Do not disassemble, repair, or modify the product. Otherwise, it may cause an electric shock, fire, injury, etc. Disassembled, repaired, and/or modified products are not covered under warranty.
- Before resetting an alarm, make sure that the run signal of the servo amplifier is off in order to prevent a sudden restart. Otherwise, it may cause an accident.
- Use a noise filter, etc., to minimize the influence of electromagnetic interference. Electromagnetic interference may affect the electronic equipment used near the servo amplifier.
- Do not burn or destroy the servo amplifier. Doing so may generate a toxic gas.
- Use the servo amplifier with the specified servo motor.
- Wire options and peripheral equipment, etc. correctly in the specified combination. Otherwise, it may cause an electric shock, fire, injury, etc.
- The electromagnetic brake on the servo motor is designed to hold the motor shaft and should not be used for ordinary braking.
- For such reasons as incorrect wiring, service life, and mechanical structure (e.g. where a ball screw and the servo motor are coupled via a timing belt), the electromagnetic brake may not hold the motor shaft. To ensure safety, install a stopper on the machine side.
- If the dynamic brake is activated at power-off, alarm occurrence, etc., do not rotate the servo motor by an external force. Otherwise, it may cause a fire.

(5) Corrective actions

⚠ CAUTION

- Ensure safety by confirming the power off, etc. before performing corrective actions. Otherwise, it may cause an accident.
- If it is assumed that a power failure, machine stoppage, or product malfunction may result in a hazardous situation, use a servo motor with an electromagnetic brake or provide an external brake system for holding purpose to prevent such hazard.
- Configure an electromagnetic brake circuit which is interlocked with an external emergency stop switch.

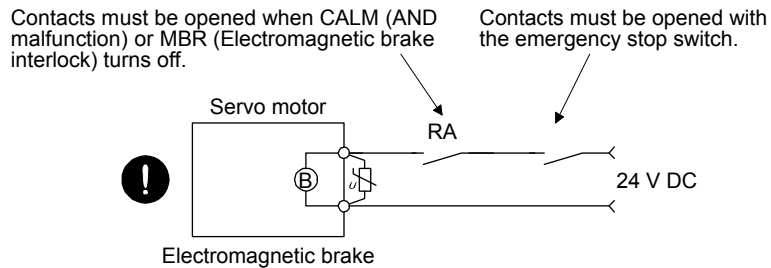

- When an alarm occurs, eliminate its cause, ensure safety, and deactivate the alarm to restart operation.
- If the molded-case circuit breaker or fuse is activated, be sure to remove the cause and secure safety before switching the power on. If necessary, replace the servo amplifier and recheck the wiring. Otherwise, it may cause smoke, fire, or an electric shock.
- Provide an adequate protection to prevent unexpected restart after an instantaneous power failure.
- After an earthquake or other natural disasters, ensure safety by checking the conditions of the installation, mounting, wiring, and equipment before switching the power on to prevent an electric shock, injury, or fire.

(6) Maintenance, inspection and parts replacement

⚠ CAUTION

- Make sure that the emergency stop circuit operates properly such that an operation can be stopped immediately and a power is shut off by the emergency stop switch.
- It is recommended that the servo amplifier be replaced every 10 years when it is used in general environment.
- When using the servo amplifier that has not been energized for an extended period of time, contact your local sales office.

(7) General instruction

- To illustrate details, the equipment in the diagrams of this Instruction Manual may have been drawn without covers and safety guards. When the equipment is operated, the covers and safety guards must be installed as specified. Operation must be performed in accordance with this Instruction Manual.

● DISPOSAL OF WASTE ●

Please dispose a servo amplifier, battery (primary battery) and other options according to your local laws and regulations.

EEPROM life

The number of write times to the EEPROM, which stores parameter settings, etc., is limited to 100,000. If the total number of the following operations exceeds 100,000, the servo amplifier may malfunction when the EEPROM reaches the end of its useful life.

- Write to the EEPROM due to parameter setting changes
- Write to the EEPROM due to device changes

STO function of the servo amplifier

The servo amplifier complies with safety integrity level 3 (SIL 3) of the IEC 61508:2010 functional safety standard. Refer to app. 15 for schedule.

When using the STO function of the servo amplifier, refer to chapter 13.

For the MR-J3-D05 safety logic unit, refer to app. 5.

Compliance with global standards

For the compliance with global standards, refer to app. 4.

«About the manuals»

You must have this Instruction Manual and the following manuals to use this servo. Ensure to prepare them to use the servo safely.

When using an MR-J4W2-0303B6, refer to chapter 18.

Relevant manuals

| Manual name | Manual No. |
|------------------------------------------------------------------|-----------------|
| MELSERVO-J4 Servo Amplifier Instruction Manual (Troubleshooting) | SH(NA)030109ENG |
| MELSERVO Servo Motor Instruction Manual (Vol. 3) (Note 1) | SH(NA)030113ENG |
| MELSERVO Linear Servo Motor Instruction Manual (Note 2) | SH(NA)030110ENG |
| MELSERVO Direct Drive Motor Instruction Manual (Note 3) | SH(NA)030112ENG |
| MELSERVO Linear Encoder Instruction Manual (Note 2, 4) | SH(NA)030111ENG |
| MELSERVO EMC Installation Guidelines | IB(NA)67310ENG |

- Note
1. It is necessary for using a rotary servo motor.
 2. It is necessary for using a linear servo motor.
 3. It is necessary for using a direct drive motor.
 4. It is necessary for using a fully closed loop system.

«Wiring»

Wires mentioned in this Instruction Manual are selected based on the ambient temperature of 40 °C.

«U.S. customary units»

U.S. customary units are not shown in this manual. Convert the values if necessary according to the following table.

| Quantity | SI (metric) unit | U.S. customary unit |
|-------------------------------|---------------------------------------------|--------------------------------|
| Mass | 1 [kg] | 2.2046 [lb] |
| Length | 1 [mm] | 0.03937 [inch] |
| Torque | 1 [N•m] | 141.6 [oz•inch] |
| Moment of inertia | 1 [(× 10 ⁻⁴ kg•m ²)] | 5.4675 [oz•inch ²] |
| Load (thrust load/axial load) | 1 [N] | 0.2248 [lbf] |
| Temperature | N [°C] × 9/5 + 32 | N [°F] |

CONTENTS

| | |
|----------------------------------------------------------------------------------------------------------------|---------------------|
| 1. FUNCTIONS AND CONFIGURATION | 1- 1 to 1-14 |
| 1.1 Summary..... | 1- 1 |
| 1.2 Function block diagram..... | 1- 3 |
| 1.3 Servo amplifier standard specifications | 1- 4 |
| 1.3.1 Integrated 2-axis servo amplifier..... | 1- 4 |
| 1.3.2 Integrated 3-axis servo amplifier..... | 1- 6 |
| 1.3.3 Combinations of servo amplifiers and servo motors..... | 1- 8 |
| 1.4 Function list..... | 1-10 |
| 1.5 Model designation..... | 1-12 |
| 1.6 Parts identification..... | 1-13 |
| 1.7 Configuration including auxiliary equipment..... | 1-14 |
| 2. INSTALLATION | 2- 1 to 2- 8 |
| 2.1 Installation direction and clearances | 2- 1 |
| 2.2 Keep out foreign materials..... | 2- 3 |
| 2.3 Encoder cable stress | 2- 3 |
| 2.4 SSCNET III cable laying | 2- 3 |
| 2.5 Inspection items..... | 2- 5 |
| 2.6 Parts having service life..... | 2- 6 |
| 2.7 Restrictions when using this product at altitude exceeding 1000 m and up to 2000 m above sea level..... | 2- 7 |
| 3. SIGNALS AND WIRING | 3- 1 to 3-38 |
| 3.1 Input power supply circuit | 3- 2 |
| 3.2 I/O signal connection example..... | 3- 5 |
| 3.2.1 For sink I/O interface..... | 3- 5 |
| 3.2.2 For source I/O interface | 3- 7 |
| 3.3 Explanation of power supply system | 3- 8 |
| 3.3.1 Signal explanations | 3- 8 |
| 3.3.2 Power-on sequence | 3-10 |
| 3.3.3 Wiring CNP1, CNP2, and CNP3..... | 3-11 |
| 3.4 Connectors and pin assignment..... | 3-13 |
| 3.5 Signal (device) explanations..... | 3-14 |
| 3.5.1 Input device | 3-14 |
| 3.5.2 Output device | 3-15 |
| 3.5.3 Output signal | 3-18 |
| 3.5.4 Power supply..... | 3-18 |
| 3.6 Forced stop deceleration function | 3-19 |
| 3.6.1 Forced stop deceleration function..... | 3-19 |
| 3.6.2 Base circuit shut-off delay time function | 3-21 |
| 3.6.3 Vertical axis freefall prevention function | 3-22 |
| 3.6.4 Residual risks of the forced stop function (EM2) | 3-22 |
| 3.7 Alarm occurrence timing chart..... | 3-23 |
| 3.7.1 When you use the forced stop deceleration function..... | 3-23 |
| 3.7.2 When you do not use the forced stop deceleration function..... | 3-25 |
| 3.8 Interfaces | 3-26 |

| | |
|-----------------------------------------------------|------|
| 3.8.1 Internal connection diagram..... | 3-26 |
| 3.8.2 Detailed description of interfaces..... | 3-27 |
| 3.8.3 Source I/O interfaces..... | 3-28 |
| 3.9 SSCNET III cable connection..... | 3-29 |
| 3.10 Servo motor with an electromagnetic brake..... | 3-31 |
| 3.10.1 Safety precautions..... | 3-31 |
| 3.10.2 Timing chart..... | 3-33 |
| 3.11 Grounding..... | 3-38 |

| | |
|-------------------|---------------------|
| 4. STARTUP | 4- 1 to 4-20 |
|-------------------|---------------------|

| | |
|------------------------------------------------------------|------|
| 4.1 Switching power on for the first time..... | 4- 2 |
| 4.1.1 Startup procedure..... | 4- 2 |
| 4.1.2 Wiring check..... | 4- 3 |
| 4.1.3 Surrounding environment..... | 4- 4 |
| 4.2 Startup..... | 4- 4 |
| 4.3 Switch setting and display of the servo amplifier..... | 4- 6 |
| 4.3.1 Switches..... | 4- 6 |
| 4.3.2 Scrolling display..... | 4-11 |
| 4.3.3 Status display of an axis..... | 4-12 |
| 4.4 Test operation..... | 4-14 |
| 4.5 Test operation mode..... | 4-14 |
| 4.5.1 Test operation mode in MR Configurator2..... | 4-15 |
| 4.5.2 Motor-less operation in controller..... | 4-17 |

| | |
|----------------------|---------------------|
| 5. PARAMETERS | 5- 1 to 5-56 |
|----------------------|---------------------|

| | |
|---------------------------------------------------------------------------|------|
| 5.1 Parameter list..... | 5- 2 |
| 5.1.1 Basic setting parameters ([Pr. PA_ _])..... | 5- 3 |
| 5.1.2 Gain/filter setting parameters ([Pr. PB_ _])..... | 5- 4 |
| 5.1.3 Extension setting parameters ([Pr. PC_ _])..... | 5- 5 |
| 5.1.4 I/O setting parameters ([Pr. PD_ _])..... | 5- 7 |
| 5.1.5 Extension setting 2 parameters ([Pr. PE_ _])..... | 5- 8 |
| 5.1.6 Extension setting 3 parameters ([Pr. PF_ _])..... | 5-10 |
| 5.1.7 Linear servo motor/DD motor setting parameters ([Pr. PL_ _])..... | 5-11 |
| 5.2 Detailed list of parameters..... | 5-13 |
| 5.2.1 Basic setting parameters ([Pr. PA_ _])..... | 5-13 |
| 5.2.2 Gain/filter setting parameters ([Pr. PB_ _])..... | 5-23 |
| 5.2.3 Extension setting parameters ([Pr. PC_ _])..... | 5-37 |
| 5.2.4 I/O setting parameters ([Pr. PD_ _])..... | 5-44 |
| 5.2.5 Extension setting 2 parameters ([Pr. PE_ _])..... | 5-48 |
| 5.2.6 Extension setting 3 parameters ([Pr. PF_ _])..... | 5-50 |
| 5.2.7 Linear servo motor/DD motor setting parameters ([Pr. PL_ _])..... | 5-53 |

| | |
|----------------------------------|---------------------|
| 6. NORMAL GAIN ADJUSTMENT | 6- 1 to 6-28 |
|----------------------------------|---------------------|

| | |
|---------------------------------------------------|------|
| 6.1 Different adjustment methods..... | 6- 1 |
| 6.1.1 Adjustment on a single servo amplifier..... | 6- 1 |
| 6.1.2 Adjustment using MR Configurator2..... | 6- 2 |
| 6.2 One-touch tuning..... | 6- 3 |
| 6.2.1 One-touch tuning flowchart..... | 6- 5 |

| | | |
|-------|----------------------------------------------------------------------|------|
| 6.2.2 | Display transition and operation procedure of one-touch tuning | 6- 7 |
| 6.2.3 | Caution for one-touch tuning | 6-17 |
| 6.3 | Auto tuning | 6-18 |
| 6.3.1 | Auto tuning mode | 6-18 |
| 6.3.2 | Auto tuning mode basis | 6-19 |
| 6.3.3 | Adjustment procedure by auto tuning | 6-20 |
| 6.3.4 | Response level setting in auto tuning mode | 6-21 |
| 6.4 | Manual mode | 6-22 |
| 6.5 | 2 gain adjustment mode | 6-25 |

| | |
|----------------------------------------|---------------------|
| 7. SPECIAL ADJUSTMENT FUNCTIONS | 7- 1 to 7-32 |
|----------------------------------------|---------------------|

| | | |
|-------|--------------------------------------------------------|------|
| 7.1 | Filter setting | 7- 1 |
| 7.1.1 | Machine resonance suppression filter | 7- 2 |
| 7.1.2 | Adaptive filter II | 7- 5 |
| 7.1.3 | Shaft resonance suppression filter | 7- 7 |
| 7.1.4 | Low-pass filter | 7- 8 |
| 7.1.5 | Advanced vibration suppression control II | 7- 8 |
| 7.1.6 | Command notch filter | 7-13 |
| 7.2 | Gain switching function | 7-15 |
| 7.2.1 | Applications | 7-15 |
| 7.2.2 | Function block diagram | 7-16 |
| 7.2.3 | Parameter | 7-17 |
| 7.2.4 | Gain switching procedure | 7-20 |
| 7.3 | Tough drive function | 7-24 |
| 7.3.1 | Vibration tough drive function | 7-24 |
| 7.3.2 | Instantaneous power failure tough drive function | 7-26 |
| 7.4 | Compliance with SEMI-F47 standard | 7-30 |
| 7.5 | Model adaptive control disabled | 7-32 |

| | |
|---------------------------|---------------------|
| 8. TROUBLESHOOTING | 8- 1 to 8-16 |
|---------------------------|---------------------|

| | | |
|-----|-----------------------------------|------|
| 8.1 | Explanation for the lists | 8- 1 |
| 8.2 | Alarm list | 8- 2 |
| 8.3 | Warning list | 8-12 |
| 8.4 | Troubleshooting at power on | 8-15 |

| | |
|----------------------|---------------------|
| 9. DIMENSIONS | 9- 1 to 9- 6 |
|----------------------|---------------------|

| | | |
|-----|-----------------------|------|
| 9.1 | Servo amplifier | 9- 1 |
| 9.2 | Connector | 9- 4 |

| | |
|----------------------------|-----------------------|
| 10. CHARACTERISTICS | 10- 1 to 10-10 |
|----------------------------|-----------------------|

| | | |
|--------|------------------------------------------------------------------------|-------|
| 10.1 | Overload protection characteristics | 10- 1 |
| 10.2 | Power supply capacity and generated loss | 10- 2 |
| 10.3 | Dynamic brake characteristics | 10- 5 |
| 10.3.1 | Dynamic brake operation | 10- 6 |
| 10.3.2 | Permissible load to motor inertia when the dynamic brake is used | 10- 8 |
| 10.4 | Cable bending life | 10- 9 |
| 10.5 | Inrush currents at power-on of main circuit and control circuit | 10- 9 |

11. OPTIONS AND PERIPHERAL EQUIPMENT

11- 1 to 11-46

| | |
|---------------------------------------------------------------------|-------|
| 11.1 Cable/connector sets | 11- 1 |
| 11.1.1 Combinations of cable/connector sets | 11- 2 |
| 11.1.2 SSCNET III cable | 11- 4 |
| 11.1.3 Battery cable/junction battery cable | 11- 6 |
| 11.1.4 MR-D05UDL3M-B STO cable | 11- 7 |
| 11.2 Regenerative options | 11- 7 |
| 11.2.1 Combination and regenerative power | 11- 7 |
| 11.2.2 Selection of regenerative option | 11- 8 |
| 11.2.3 Parameter setting | 11-10 |
| 11.2.4 Connection of regenerative option | 11-11 |
| 11.2.5 Dimensions | 11-12 |
| 11.3 Battery | 11-13 |
| 11.3.1 Selection of battery | 11-13 |
| 11.3.2 MR-BAT6V1SET-A battery | 11-14 |
| 11.3.3 MR-BT6VCASE battery case | 11-17 |
| 11.3.4 MR-BAT6V1 battery | 11-23 |
| 11.4 MR Configurator2 | 11-24 |
| 11.4.1 Specifications | 11-24 |
| 11.4.2 System configuration | 11-25 |
| 11.4.3 Precautions for using USB communication function | 11-26 |
| 11.5 Selection example of wires | 11-27 |
| 11.6 Molded-case circuit breakers, fuses, magnetic contactors | 11-29 |
| 11.7 Power factor improving AC reactors | 11-31 |
| 11.8 Relays (recommended) | 11-32 |
| 11.9 Noise reduction techniques | 11-32 |
| 11.10 Earth-leakage current breaker | 11-39 |
| 11.11 EMC filter (recommended) | 11-42 |
| 11.12 Junction terminal block MR-TB26A | 11-45 |

12. ABSOLUTE POSITION DETECTION SYSTEM

12- 1 to 12- 4

| | |
|-------------------------------------------------------------------|-------|
| 12.1 Summary | 12- 1 |
| 12.1.1 Features | 12- 1 |
| 12.1.2 Structure | 12- 1 |
| 12.1.3 Parameter setting | 12- 1 |
| 12.1.4 Confirmation of absolute position detection data | 12- 2 |
| 12.2 Battery | 12- 3 |
| 12.2.1 Using MR-BAT6V1SET battery (only for MR-J4W2-0303B6) | 12- 3 |
| 12.2.2 Using MR-BT6VCASE battery case | 12- 4 |

13. USING STO FUNCTION

13- 1 to 13-14

| | |
|-------------------------------------------------|-------|
| 13.1 Introduction | 13- 1 |
| 13.1.1 Summary | 13- 1 |
| 13.1.2 Terms related to safety | 13- 1 |
| 13.1.3 Cautions | 13- 1 |
| 13.1.4 Residual risks of the STO function | 13- 2 |
| 13.1.5 Specifications | 13- 3 |
| 13.1.6 Maintenance | 13- 4 |

| | | |
|--------|----------------------------------------------------------------------------------|-------|
| 13.2 | STO I/O signal connector (CN8) and signal layouts..... | 13- 4 |
| 13.2.1 | Signal layouts..... | 13- 4 |
| 13.2.2 | Signal (device) explanations..... | 13- 5 |
| 13.2.3 | How to pull out the STO cable..... | 13- 5 |
| 13.3 | Connection example..... | 13- 6 |
| 13.3.1 | Connection example for CN8 connector..... | 13- 6 |
| 13.3.2 | External I/O signal connection example using an MR-J3-D05 safety logic unit..... | 13- 7 |
| 13.3.3 | External I/O signal connection example using an external safety relay unit..... | 13- 9 |
| 13.3.4 | External I/O signal connection example using a motion controller..... | 13-10 |
| 13.4 | Detailed description of interfaces..... | 13-11 |
| 13.4.1 | Sink I/O interface..... | 13-11 |
| 13.4.2 | Source I/O interface..... | 13-12 |

| | |
|---------------------------------------|-----------------------|
| 14. USING A LINEAR SERVO MOTOR | 14- 1 to 14-32 |
|---------------------------------------|-----------------------|

| | | |
|--------|--------------------------------------------------------------------------|-------|
| 14.1 | Functions and configuration..... | 14- 1 |
| 14.1.1 | Summary..... | 14- 1 |
| 14.1.2 | Servo system with auxiliary equipment..... | 14- 2 |
| 14.2 | Signals and wiring..... | 14- 3 |
| 14.3 | Operation and functions..... | 14- 5 |
| 14.3.1 | Startup..... | 14- 5 |
| 14.3.2 | Magnetic pole detection..... | 14- 8 |
| 14.3.3 | Home position return..... | 14-16 |
| 14.3.4 | Test operation mode in MR Configurator2..... | 14-20 |
| 14.3.5 | Operation from controller..... | 14-23 |
| 14.3.6 | Function..... | 14-25 |
| 14.3.7 | Absolute position detection system..... | 14-27 |
| 14.4 | Characteristics..... | 14-28 |
| 14.4.1 | Overload protection characteristics..... | 14-28 |
| 14.4.2 | Power supply capacity and generated loss..... | 14-29 |
| 14.4.3 | Dynamic brake characteristics..... | 14-31 |
| 14.4.4 | Permissible load to motor mass ratio when the dynamic brake is used..... | 14-32 |

| | |
|---------------------------------------|-----------------------|
| 15. USING A DIRECT DRIVE MOTOR | 15- 1 to 15-24 |
|---------------------------------------|-----------------------|

| | | |
|--------|-----------------------------------------------|-------|
| 15.1 | Functions and configuration..... | 15- 1 |
| 15.1.1 | Summary..... | 15- 1 |
| 15.1.2 | Servo system with auxiliary equipment..... | 15- 3 |
| 15.2 | Signals and wiring..... | 15- 4 |
| 15.3 | Operation and functions..... | 15- 5 |
| 15.3.1 | Startup procedure..... | 15- 6 |
| 15.3.2 | Magnetic pole detection..... | 15- 7 |
| 15.3.3 | Operation from controller..... | 15-15 |
| 15.3.4 | Function..... | 15-16 |
| 15.4 | Characteristics..... | 15-18 |
| 15.4.1 | Overload protection characteristics..... | 15-18 |
| 15.4.2 | Power supply capacity and generated loss..... | 15-19 |
| 15.4.3 | Dynamic brake characteristics..... | 15-21 |

16. FULLY CLOSED LOOP SYSTEM

16- 1 to 16-24

| | |
|-------------------------------------------------------------------------------|-------|
| 16.1 Functions and configuration | 16- 1 |
| 16.1.1 Function block diagram..... | 16- 1 |
| 16.1.2 Selecting procedure of control mode..... | 16- 3 |
| 16.1.3 System configuration..... | 16- 4 |
| 16.2 Load-side encoder..... | 16- 5 |
| 16.2.1 Linear encoder..... | 16- 5 |
| 16.2.2 Rotary encoder..... | 16- 5 |
| 16.2.3 Configuration diagram of encoder cable..... | 16- 5 |
| 16.2.4 MR-J4FCCBL03M branch cable..... | 16- 6 |
| 16.3 Operation and functions..... | 16- 7 |
| 16.3.1 Startup..... | 16- 7 |
| 16.3.2 Home position return..... | 16-14 |
| 16.3.3 Operation from controller..... | 16-17 |
| 16.3.4 Fully closed loop control error detection functions..... | 16-19 |
| 16.3.5 Auto tuning function..... | 16-20 |
| 16.3.6 Machine analyzer function..... | 16-20 |
| 16.3.7 Test operation mode..... | 16-20 |
| 16.3.8 Absolute position detection system under fully closed loop system..... | 16-21 |
| 16.3.9 About MR Configurator2..... | 16-22 |

17. APPLICATION OF FUNCTIONS

17- 1 to 17-72

| | |
|-----------------------------------------------------------------------------------|-------|
| 17.1 J3 compatibility mode..... | 17- 1 |
| 17.1.1 Outline of J3 compatibility mode..... | 17- 1 |
| 17.1.2 Operation modes supported by J3 compatibility mode..... | 17- 1 |
| 17.1.3 J3 compatibility mode supported function list..... | 17- 2 |
| 17.1.4 How to switch J4 mode/J3 compatibility mode..... | 17- 5 |
| 17.1.5 How to use the J3 compatibility mode..... | 17- 6 |
| 17.1.6 Cautions for switching J4 mode/J3 compatibility mode..... | 17- 7 |
| 17.1.7 Cautions for the J3 compatibility mode..... | 17- 7 |
| 17.1.8 Change of specifications of "J3 compatibility mode" switching process..... | 17- 9 |
| 17.1.9 J3 extension function..... | 17-11 |
| 17.2 Scale measurement function..... | 17-65 |
| 17.2.1 Functions and configuration..... | 17-65 |
| 17.2.2 Scale measurement encoder..... | 17-67 |
| 17.2.3 How to use scale measurement function..... | 17-70 |

18. MR-J4W2-0303B6 SERVO AMPLIFIER

18- 1 to 18-54

| | |
|---------------------------------------------------------------|-------|
| 18.1 Functions and configuration | 18- 1 |
| 18.1.1 Summary..... | 18- 1 |
| 18.1.2 Function block diagram..... | 18- 2 |
| 18.1.3 Servo amplifier standard specifications..... | 18- 3 |
| 18.1.4 Combinations of servo amplifiers and servo motors..... | 18- 4 |
| 18.1.5 Function list..... | 18- 5 |
| 18.1.6 Model definition..... | 18- 7 |
| 18.1.7 Parts identification..... | 18- 8 |
| 18.1.8 Configuration including peripheral equipment..... | 18- 9 |
| 18.2 Installation..... | 18-10 |

| | | |
|---------|--------------------------------------------------------------------------|-------|
| 18.2.1 | Installation direction and clearances..... | 18-11 |
| 18.2.2 | Installation by DIN rail | 18-13 |
| 18.3 | Signals and wiring..... | 18-15 |
| 18.3.1 | Input power supply circuit | 18-16 |
| 18.3.2 | Explanation of power supply system..... | 18-18 |
| 18.3.3 | Selection of main circuit power supply/control circuit power supply..... | 18-22 |
| 18.3.4 | Power-on sequence | 18-22 |
| 18.3.5 | I/O Signal Connection Example | 18-23 |
| 18.3.6 | Connectors and pin assignment | 18-26 |
| 18.3.7 | Signal (device) explanations | 18-27 |
| 18.3.8 | Alarm occurrence timing chart | 18-34 |
| 18.3.9 | Interfaces | 18-36 |
| 18.3.10 | Grounding | 18-39 |
| 18.4 | Startup | 18-40 |
| 18.4.1 | Startup procedure | 18-41 |
| 18.4.2 | Troubleshooting when "24V ERROR" lamp turns on..... | 18-42 |
| 18.4.3 | Wiring check..... | 18-42 |
| 18.4.4 | Surrounding environment..... | 18-43 |
| 18.5 | Switch setting and display of the servo amplifier..... | 18-44 |
| 18.6 | Dimensions | 18-45 |
| 18.7 | Characteristics | 18-46 |
| 18.7.1 | Overload protection characteristics | 18-46 |
| 18.7.2 | Power supply capacity and generated loss | 18-47 |
| 18.7.3 | Dynamic brake characteristics | 18-47 |
| 18.7.4 | Inrush currents at power-on of main circuit and control circuit..... | 18-49 |
| 18.8 | Options and peripheral equipment | 18-50 |
| 18.8.1 | Cable/connector sets | 18-51 |
| 18.8.2 | Combinations of cable/connector sets | 18-51 |
| 18.8.3 | Selection example of wires | 18-53 |
| 18.8.4 | Circuit protector..... | 18-54 |

| |
|----------|
| APPENDIX |
|----------|

| |
|--------------------|
| App.- 1 to App.-59 |
|--------------------|

| | | |
|---------|---------------------------------------------------------------------------------------------------------------------------|---------|
| App. 1 | Auxiliary equipment manufacturer (for reference) | App.- 1 |
| App. 2 | Handling of AC servo amplifier batteries for the United Nations Recommendations on the Transport of Dangerous Goods | App.- 1 |
| App. 3 | Symbol for the new EU Battery Directive..... | App.- 4 |
| App. 4 | Compliance with global standards | App.- 5 |
| App. 5 | MR-J3-D05 Safety logic unit | App.-21 |
| App. 6 | EC declaration of conformity | App.-39 |
| App. 7 | How to replace servo amplifier without magnetic pole detection..... | App.-42 |
| App. 8 | Two-wire type encoder cable for HG-MR/HG-KR..... | App.-43 |
| App. 9 | SSCNET III cable (SC-J3BUS_M-C) manufactured by Mitsubishi Electric System & Service | App.-45 |
| App. 10 | CNP_crimping connector | App.-45 |
| App. 11 | Recommended cable for servo amplifier power supply | App.-46 |
| App. 12 | Special specification..... | App.-48 |
| App. 13 | Driving on/off of main circuit power supply with DC power supply | App.-51 |
| App. 14 | Optional data monitor function | App.-53 |
| App. 15 | STO function with SIL 3 certification | App.-56 |

App. 16 Status of general-purpose AC servo products for compliance with the China RoHS
directiveApp.-58

1. FUNCTIONS AND CONFIGURATION

1. FUNCTIONS AND CONFIGURATION

| POINT |
|------------------------------------------------------------------------------------------------------------------------------------------------------------------------------------------------------------------------|
| ● In MELSERVO-J4 series, ultra-small capacity servo amplifiers compatible with 48 V DC and 24 V DC power supplies are available as MR-J4W2-0303B6. Refer to chapter 18 for details of MR-J4W2-0303B6 servo amplifiers. |

1.1 Summary

The MELSERVO-J4 series of multi-axis servo amplifiers inherits the high performance, sophisticated functions, and usability of the MR-J4-B servo amplifiers, and ensures space saving, reduced wiring, and energy saving.

The MR-J4W_-B servo amplifier is connected to controllers, including a servo system controller, on the high-speed synchronous network, SSCNET III/H. The servo amplifier directly receives a command from a controller to drive a servo motor.

One MR-J4W_-B servo amplifier can drive two or three servo motors. The footprint of one MR-J4W_-B servo amplifier is considerably smaller than that of two or three MR-J4-B servo amplifiers. You can install MR-J4W_-B servo amplifiers without clearance between them. This makes your system more compact.

The multi-axis structure enables multiple axes to share the SSCNET III cable, control circuit power supply cable, and main circuit power supply cable. This ensures reduced wiring.

For the MR-J4W_-B servo amplifier, the parameter settings allow you to use a rotary servo motor, linear servo motor, and direct drive motor for each axis. The axes can be connected to a rotary servo motor, linear servo motor, and direct drive motor, which have different capacity. Using a linear servo motor or direct drive motor simplifies the system, and using the MR-J4W_-B servo amplifier downsizes the equipment, enhances the equipment performance, and ensures space saving.

Using regenerative energy generated when a servo motor decelerates ensures energy saving.

Depending on the operating conditions, the regenerative option is not required.

As the MR-J4-B servo amplifier, the MR-J4W_-B servo amplifier supports the one-touch tuning and the real-time auto tuning. This enables you to easily adjust the servo gain according to the machine.

The tough drive function and the drive recorder function, which are well-received in the MELSERVO-JN series, have been improved. The MR-J4W_-B servo amplifier supports the improved functions. Additionally, the preventive maintenance support function detects an error in the machine parts. This function provides strong support for the machine maintenance and inspection.

On the SSCNET III/H network, the stations are connected with a maximum distance of 100 m between them. This allows you to create a large system.

The MR-J4W_-B servo amplifier supports the STO (Safe Torque Off) function. When the servo amplifier is connected to a SSCNET III/H-compatible servo system controller, in addition to the STO function, the servo amplifier also supports the SS1 (Safe Stop 1), SS2 (Safe Stop 2), SOS (Safe Operating Stop), SLS (Safely-Limited Speed), SBC (Safe Brake Control) and SSM (Safe Speed Monitor) functions.

The servo amplifier has a USB communication interface. Therefore, you can connect the servo amplifier to the personal computer with MR Configurator2 installed to perform the parameter setting, test operation, gain adjustment, and others.

1. FUNCTIONS AND CONFIGURATION

Table 1.1 Connectors to connect external encoders

| Operation mode | External encoder communication method | Connector | |
|----------------------------|----------------------------------------|--------------------------------------------|-------------------------------------------------|
| | | MR-J4W2-_B | MR-J4W3-_B |
| Linear servo motor system | Two-wire type | CN2A (Note 1) CN2B (Note 1) | CN2A (Note 1) CN2B (Note 1) CN2C (Note 1) |
| | Four-wire type | | |
| | A/B/Z-phase differential output method | | |
| Fully closed loop system | Two-wire type | CN2A (Note 2, 3, 4) CN2B (Note 2, 3, 4) | |
| | Four-wire type (Note 6) | | |
| | A/B/Z-phase differential output method | | |
| Scale measurement function | Two-wire type | CN2A (Note 2, 3, 5) CN2B (Note 2, 3, 5) | |
| | Four-wire type (Note 6) | | |
| | A/B/Z-phase differential output method | | |

- Note
1. The MR-J4THCBL03M branch cable is necessary.
 2. The MR-J4FCCBL03M branch cable is necessary.
 3. When the communication method of the servo motor encoder is four-wire type and A/B/Z-phase differential output method, MR-J4W2-_B cannot be used. Use an MR-J4-_B-RJ.
 4. This is used with servo amplifiers with software version A3 or later.
 5. This is used with servo amplifiers with software version A8 or later.
 6. The synchronous encoder Q171ENC-W8 cannot be used due to the four-wire type.

1. FUNCTIONS AND CONFIGURATION

1.3 Servo amplifier standard specifications

1.3.1 Integrated 2-axis servo amplifier

| Model MR-J4W2- | | 22B | 44B | 77B | 1010B | |
|---------------------------------------------------|---------------------------------------------------------------------------------------------------------------------------|------------------------------------------------------------------------------------------------------------------------------------------------------------------------------------------------------------------------------------------------------------------------------------------------------------------|------|------|-------------------------------------------|--|
| Output | Rated voltage | 3-phase 170 V AC | | | | |
| | Rated current (each axis) [A] | 1.5 | 2.8 | 5.8 | 6.0 | |
| Main circuit power supply input | Voltage/Frequency | 3-phase or 1-phase 200 V AC to 240 V AC, 50 Hz/60 Hz | | | 3-phase 200 V AC to 240 V AC, 50 Hz/60 Hz | |
| | Rated current (Note 11) [A] | 2.9 | 5.2 | 7.5 | 9.8 | |
| | Permissible voltage fluctuation | 3-phase or 1-phase 170 V AC to 264 V AC | | | 3-phase 170 V AC to 264 V AC | |
| | Permissible frequency fluctuation | Within $\pm 5\%$ | | | | |
| | Power supply capacity [kVA] | Refer to section 10.2. | | | | |
| | Inrush current [A] | Refer to section 10.5. | | | | |
| Control circuit power supply input | Voltage/Frequency | 1-phase 200 V AC to 240 V AC, 50 Hz/60 Hz | | | | |
| | Rated current [A] | 0.4 | | | | |
| | Permissible voltage fluctuation | 1-phase 170 V AC to 264 V AC | | | | |
| | Permissible frequency fluctuation | Within $\pm 5\%$ | | | | |
| | Power consumption [W] | 55 | | | | |
| | Inrush current [A] | Refer to section 10.5. | | | | |
| Interface power supply | Voltage | 24 V DC $\pm 10\%$ | | | | |
| | Power supply capacity | 0.35 A (Note 1) | | | | |
| Control method | | Sine-wave PWM control, current control method | | | | |
| Capacitor regeneration | Reusable regenerative energy (Note 2) [J] | 17 | 21 | 44 | | |
| | Moment of inertia J equivalent to the permissible charging amount (Note 3) [$\times 10^{-4}$ kg \cdot m ²] | 3.45 | 4.26 | 8.92 | | |
| | Mass equivalent to the permissible charging amount (Note 4) [kg] | LM-H3 | 3.8 | 4.7 | 9.8 | |
| | | LM-K2 LM-U2 | 8.5 | 10.5 | 22.0 | |
| Built-in regenerative resistance [W] | | 20 | | 100 | | |
| Dynamic brake | | Built-in | | | | |
| SSCNET III/H command communication cycle (Note 9) | | 0.222 ms, 0.444 ms, 0.888 ms | | | | |
| Communication function | | USB: Connect a personal computer (MR Configurator2 compatible) | | | | |
| Encoder output pulse | | Compatible (A/B-phase pulse) | | | | |
| Analog monitor | | None | | | | |
| Fully closed loop control | | Compatible (Note 8) | | | | |
| Scale measurement function | | Compatible (Note 10) | | | | |
| Load-side encoder interface | | Mitsubishi Electric high-speed serial communication (Note 6) | | | | |
| Protective functions | | Overcurrent shut-off, regenerative overvoltage shut-off, overload shut-off (electronic thermal), servo motor overheat protection, encoder error protection, regenerative error protection, undervoltage protection, instantaneous power failure protection, overspeed protection, and error excessive protection | | | | |

1. FUNCTIONS AND CONFIGURATION

| Model MR-J4W2- | | 22B | 44B | 77B | 1010B |
|----------------------------------|--------------------------------------------------------------------------------|------------------------------------------------------------------------------------------------|----------------------------------|-----|-------|
| Functional safety | | STO (IEC/EN 61800-5-2) (Note 7) | | | |
| Safety performance | Standards certified by CB (Note 12) | EN ISO 13849-1 Category 3 PL e, IEC 61508 SIL 3, EN 62061 SIL CL3, EN 61800-5-2 | | | |
| | Response performance | 8 ms or less (STO input off → energy shut off) | | | |
| | Test pulse input (STO) (Note 5) | Test pulse interval: 1 Hz to 25 Hz Test pulse off time: Up to 1 ms | | | |
| | Mean time to dangerous failure (MTTFd) | MTTFd ≥ 100 [years] (314a) | | | |
| | Diagnosis converge (DC) | DC = Medium, 97.6 [%] | | | |
| | Average probability of dangerous failures per hour (PFH) | 6.4 × 10 ⁻⁹ [1/h] | | | |
| Compliance with global standards | CE marking | LVD: EN 61800-5-1 EMC: EN 61800-3 MD: EN ISO 13849-1, EN 61800-5-2, EN 62061 | | | |
| | UL standard | UL 508C | | | |
| Structure (IP rating) | | Natural cooling, open (IP20) | Force cooling, open (IP20) | | |
| Close mounting | | Possible | | | |
| Environment | Ambient temperature | Operation | 0 °C to 55 °C (non-freezing) | | |
| | | Storage | -20 °C to 65 °C (non-freezing) | | |
| | Ambient humidity | Operation | 5 %RH to 90 %RH (non-condensing) | | |
| | | Storage | | | |
| | Ambience | Indoors (no direct sunlight), free from corrosive gas, flammable gas, oil mist, dust, and dirt | | | |
| | Altitude | 2000 m or less above sea level (Note 13) | | | |
| Vibration | 5.9 m/s ² or less at 10 Hz to 55 Hz (directions of X, Y and Z axes) | | | | |
| Mass [kg] | | 1.5 | | 2.0 | |

- Note 1. 0.35 A is the value applicable when all I/O signals are used. The current capacity can be decreased by reducing the number of I/O points.
2. Reusable regenerative energy corresponds to energy generated under the following conditions.
 Rotary servo motor: Regenerative energy is generated when the machine, whose moment of inertia is equivalent to the permissible charging amount, decelerates from the rated speed to stop.
 Linear servo motor: Regenerative energy is generated when the machine, whose mass is equivalent to the permissible charging amount, decelerates from the maximum speed to stop.
 Direct drive motor: Regenerative energy is generated when the machine, whose moment of inertia is equivalent to the permissible charging amount, decelerates from the rated speed to stop.
3. Moment of inertia when the motor decelerates from the rated speed to stop
 Moment of inertia for two axes when two motors decelerate simultaneously
 Moment of inertia for each axis when multiple motors do not decelerate simultaneously
 The values also apply to the direct drive motor.
4. Mass when the machine decelerates from the maximum speed to stop
 The primary-side (coil) mass is included.
 Mass for two axes when two motors decelerate simultaneously
 Mass for each axis when multiple motors do not decelerate simultaneously
5. Test pulse is a signal which instantaneously turns off a signal to the servo amplifier at a constant period for external circuit to self-diagnose.
6. The load-side encoder is compatible only with two-wire type communication method. Not compatible with pulse train interface (A/B/Z-phase differential output type).
7. STO is common for all axes.
8. Fully closed loop control is compatible with the servo amplifiers with software version A3 or later.
 Check the software version of the servo amplifier using MR Configurator2.
9. The command communication cycle depends on the controller specifications and the number of axes connected.
10. The scale measurement function is available for the MR-J4W2-_B servo amplifiers of software version A8 or later. Check the software version of the servo amplifier with MR Configurator2.
11. This value is applicable when a 3-phase power supply is used.
12. The safety level depends on the setting value of [Pr. PF18 STO diagnosis error detection time] and whether STO input diagnosis by TOFB output is performed or not. For details, refer to the Function column of [Pr. PF18] in section 5.2.6.
13. Follow the restrictions in section 2.7 when using this product at altitude exceeding 1000 m and up to 2000 m above sea level.

1. FUNCTIONS AND CONFIGURATION

1.3.2 Integrated 3-axis servo amplifier

| Model MR-J4W3- | | 222B | 444B | |
|---------------------------------------------------|------------------------------------------------------------------------------------------------------------------------------------------------------------------------------------------------------------------------------------------------------------------------------------------------------------------|------------------------------------------------------|------|------|
| Output | Rated voltage | 3-phase 170 V AC | | |
| | Rated current (each axis) [A] | 1.5 | 2.8 | |
| Main circuit power supply input | Power supply /Frequency | 3-phase or 1-phase 200 V AC to 240 V AC, 50 Hz/60 Hz | | |
| | Rated current (Note 9) [A] | 4.3 | 7.8 | |
| | Permissible voltage fluctuation | 3-phase or 1-phase 170 V AC to 264 V AC, 50 Hz/60 Hz | | |
| | Permissible frequency fluctuation | Within $\pm 5\%$ | | |
| | Power supply capacity [kVA] | Refer to section 10.2. | | |
| | Inrush current [A] | Refer to section 10.5. | | |
| Control circuit power supply input | Power supply /Frequency | 1-phase 200 V AC to 240 V AC, 50 Hz/60 Hz | | |
| | Rated current [A] | 0.4 | | |
| | Permissible voltage fluctuation | 1-phase 170 V AC to 264 V AC | | |
| | Permissible frequency fluctuation | Within $\pm 5\%$ | | |
| | Power consumption [W] | 55 | | |
| | Inrush current [A] | Refer to section 10.5. | | |
| Interface power supply | Voltage/Frequency | 24 V DC $\pm 10\%$ | | |
| | Power supply capacity | 0.45 A (Note 1) | | |
| Control method | Sine-wave PWM control, current control method | | | |
| Capacitor regeneration | Reusable regenerative energy (Note 2) [J] | 21 | 30 | |
| | Moment of inertia J equivalent to the permissible charging amount (Note 3) [$\times 10^{-4}$ kg \cdot m ²] | 4.26 | 6.08 | |
| | Mass equivalent to the permissible charging amount (Note 4) [kg] | LM-H3 | 4.7 | 6.7 |
| | | LM-K2 LM-U2 | 10.5 | 15.0 |
| Built-in regenerative resistance [W] | 30 | 100 | | |
| Dynamic brake | Built-in | | | |
| SSCNET III/H command communication cycle (Note 7) | 0.222 ms (Note 8), 0.444 ms, 0.888 ms | | | |
| Communication function | USB: Connect a personal computer (MR Configurator2 compatible) | | | |
| Encoder output pulse | Not compatible | | | |
| Analog monitor | None | | | |
| Fully closed loop control | Not compatible | | | |
| Scale measurement function | Not compatible | | | |
| Protective functions | Overcurrent shut-off, regenerative overvoltage shut-off, overload shut-off (electronic thermal), servo motor overheat protection, encoder error protection, regenerative error protection, undervoltage protection, instantaneous power failure protection, overspeed protection, and error excessive protection | | | |

1. FUNCTIONS AND CONFIGURATION

| Model MR-J4W3- | | 222B | 444B | |
|----------------------------------|--------------------------------------------------------------------------------|------------------------------------------------------------------------------------------------|----------------------------------|--|
| Functional safety | | STO (IEC/EN 61800-5-2) (Note 6) | | |
| Safety performance | Standards certified by CB (Note 10) | EN ISO 13849-1 Category 3 PL e, IEC 61508 SIL 3, EN 62061 SIL CL3, EN 61800-5-2 | | |
| | Response performance | 8 ms or less (STO input off → energy shut off) | | |
| | Test pulse input (STO) (Note 5) | Test pulse interval: 1 Hz to 25 Hz Test pulse off time: Up to 1 ms | | |
| | Mean time to dangerous failure (MTTFd) | MTTFd ≥ 100 [years] (314a) | | |
| | Diagnosis converge (DC) | DC = Medium, 97.6 [%] | | |
| | Average probability of dangerous failures per hour (PFH) | 6.4 × 10 ⁻⁹ [1/h] | | |
| Compliance with global standards | CE marking | LVD: EN 61800-5-1 EMC: EN 61800-3 MD: EN ISO 13849-1, EN 61800-5-2, EN 62061 | | |
| | UL standard | UL 508C | | |
| Structure (IP rating) | | Force cooling, open (IP20) | | |
| Close mounting | | Possible | | |
| Environment | Ambient temperature | Operation | 0 °C to 55 °C (non-freezing) | |
| | | Storage | -20 °C to 65 °C (non-freezing) | |
| | Ambient humidity | Operation | 5 %RH to 90 %RH (non-condensing) | |
| | | Storage | | |
| | Ambience | Indoors (no direct sunlight), free from corrosive gas, flammable gas, oil mist, dust, and dirt | | |
| | Altitude | 2000 m or less above sea level (Note 11) | | |
| Vibration | 5.9 m/s ² or less at 10 Hz to 55 Hz (directions of X, Y and Z axes) | | | |
| Mass [kg] | | 1.9 | | |

- Note 1. 0.45 A is the value applicable when all I/O signals are used. The current capacity can be decreased by reducing the number of I/O points.
2. Reusable regenerative energy corresponds to energy generated under the following conditions.
 Rotary servo motor: Regenerative energy is generated when the machine, whose moment of inertia is equivalent to the permissible charging amount, decelerates from the rated speed to stop.
 Linear servo motor: Regenerative energy is generated when the machine, whose mass is equivalent to the permissible charging amount, decelerates from the maximum speed to stop.
 Direct drive motor: Regenerative energy is generated when the machine, whose moment of inertia is equivalent to the permissible charging amount, decelerates from the rated speed to stop.
3. Moment of inertia when the machine decelerates from the rated speed to stop
 Moment of inertia for three axes when three motors decelerate simultaneously
 Moment of inertia for each axis when multiple motors do not decelerate simultaneously
 The values also apply to the direct drive motor.
4. Mass when the machine decelerates from the maximum speed to stop
 The primary-side (coil) mass is included.
 Mass for three axes when three motors decelerate simultaneously
 Mass for each axis when multiple motors do not decelerate simultaneously
5. Test pulse is a signal which instantaneously turns off a signal to the servo amplifier at a constant period for external circuit to self-diagnose.
6. STO is common for all axes.
7. The command communication cycle depends on the controller specifications and the number of axes connected.
8. Servo amplifier with software version A3 or later is compatible with the command communication cycle of 0.222 ms. However, note that the following functions are not available when 0.222 ms is used: auto tuning (real time, one-touch, and vibration suppression control), adaptive filter II, vibration tough drive, and power monitoring.
9. This value is applicable when a 3-phase power supply is used.
10. The safety level depends on the setting value of [Pr. PF18 STO diagnosis error detection time] and whether STO input diagnosis by TOFB output is performed or not. For details, refer to the Function column of [Pr. PF18] in section 5.2.6.
11. Follow the restrictions in section 2.7 when using this product at altitude exceeding 1000 m and up to 2000 m above sea level.

1. FUNCTIONS AND CONFIGURATION

1.3.3 Combinations of servo amplifiers and servo motors

(1) MR-J4W2-_B servo amplifier

| Servo amplifier | Rotary servo motor | | | | | Linear servo motor (primary side) | Direct drive motor |
|-----------------|-----------------------|-----------------------|-----------------------|-------|--------------------------|-------------------------------------------------------------------------------------------------------------------------------------------------------------------------------------------------------------------------------------|------------------------------------------------------------------------------------------------------------------------------------------------------------------------------------------------------------------|
| | HG-KR | HG-MR | HG-SR | HG-UR | HG-JR | | |
| MR-J4W2-22B | 053 13 23 | 053 13 23 | | | | LM-U2PAB-05M-0SS0 LM-U2PBB-07M-1SS0 | TM-RFM002C20 TM-RG2M002C30 (Note 1) TM-RU2M002C30 (Note 1) TM-RG2M004E30 (Note 1) TM-RU2M004E30 (Note 1) |
| MR-J4W2-44B | 053 13 23 43 | 053 13 23 43 | | | | LM-H3P2A-07P-BSS0 LM-H3P3A-12P-CSS0 LM-K2P1A-01M-2SS1 LM-U2PAB-05M-0SS0 LM-U2PAD-10M-0SS0 LM-U2PAF-15M-0SS0 LM-U2PBB-07M-1SS0 | TM-RFM002C20 TM-RFM004C20 TM-RG2M002C30 (Note 1) TM-RU2M002C30 (Note 1) TM-RG2M004E30 (Note 1, 2) TM-RU2M004E30 (Note 1, 2) TM-RG2M009G30 (Note 1) TM-RU2M009G30 (Note 1) |
| MR-J4W2-77B | 43 73 | 43 73 | 51 52 | 72 | 53 73 | LM-H3P2A-07P-BSS0 LM-H3P3A-12P-CSS0 LM-H3P3B-24P-CSS0 LM-H3P3C-36P-CSS0 LM-H3P7A-24P-ASS0 LM-K2P1A-01M-2SS1 LM-K2P2A-02M-1SS1 LM-U2PAD-10M-0SS0 LM-U2PAF-15M-0SS0 LM-U2PBD-15M-1SS0 LM-U2PBF-22M-1SS0 | TM-RFM004C20 TM-RFM006C20 TM-RFM006E20 TM-RFM012E20 TM-RFM012G20 TM-RFM040J10 |
| MR-J4W2-1010B | 43 73 | 43 73 | 51 81 52 102 | 72 | 53 (Note 3) 73 103 | LM-H3P2A-07P-BSS0 LM-H3P3A-12P-CSS0 LM-H3P3B-24P-CSS0 LM-H3P3C-36P-CSS0 LM-H3P7A-24P-ASS0 LM-K2P1A-01M-2SS1 LM-K2P2A-02M-1SS1 LM-U2PAD-10M-0SS0 LM-U2PAF-15M-0SS0 LM-U2PBD-15M-1SS0 LM-U2PBF-22M-1SS0 | TM-RFM004C20 TM-RFM006C20 TM-RFM006E20 TM-RFM012E20 TM-RFM018E20 TM-RFM012G20 TM-RFM040J10 |

- Note 1. This is available with servo amplifiers with software version C8 or later.
 2. This combination increases the maximum torque of the servo motor to 400%.
 3. The combination increases the rated torque and the maximum torque.

1. FUNCTIONS AND CONFIGURATION

(2) MR-J4W3-_B servo amplifier

| Servo amplifier | Rotary servo motor | | Linear servo motor (primary side) | Direct drive motor |
|-----------------|--------------------|-------|-------------------------------------------------------------------------------------------------------------------------------------------------|------------------------------|
| | HG-KR | HG-MR | | |
| MR-J4W3-222B | | | LM-U2PAB-05M-0SS0 LM-U2PBB-07M-1SS0 | TM-RFM002C20 |
| | | | | TM-RG2M002C30 (Note 1) |
| | 053 | 053 | | TM-RU2M002C30 (Note 1) |
| | 13 | 13 | | TM-RG2M004E30 (Note 1) |
| | 23 | 23 | | TM-RU2M004E30 (Note 1) |
| MR-J4W3-444B | | | LM-H3P2A-07P-BSS0 LM-H3P3A-12P-CSS0 LM-K2P1A-01M-2SS1 LM-U2PAB-05M-0SS0 LM-U2PAD-10M-0SS0 LM-U2PAF-15M-0SS0 LM-U2PBB-07M-1SS0 | TM-RFM002C20 |
| | | | | TM-RFM004C20 |
| | | | | TM-RG2M002C30 (Note 1) |
| | | | | TM-RU2M002C30 (Note 1) |
| | 053 | 053 | | TM-RG2M004E30 (Note 1, 2) |
| | 13 | 13 | | TM-RU2M004E30 (Note 1, 2) |
| | 23 | 23 | | TM-RG2M009G30 (Note 1) |
| | 43 | 43 | | TM-RU2M009G30 (Note 1) |
| | | | | |
| | | | | |

- Note
1. This is available with servo amplifiers with software version C8 or later.
 2. This combination increases the maximum torque of the servo motor to 400%.

1. FUNCTIONS AND CONFIGURATION

1.4 Function list

The following table lists the functions of this servo. For details of the functions, refer to the reference field.

| Function | Description | Detailed explanation |
|-------------------------------------------|---------------------------------------------------------------------------------------------------------------------------------------------------------------------------------------------------------------------------------------------------------------------------------------------------------------------------------------------------------------------------------------------------------------------------------------------------|--------------------------|
| Model adaptive control | This realizes a high response and stable control following the ideal model. The two-degrees-of-freedom-model model adaptive control enables you to set a response to the command and response to the disturbance separately. Additionally, this function can be disabled. Refer to section 7.5 for disabling this function. This is used by servo amplifiers with software version B4 or later. Check the software version with MR Configurator2. | |
| Position control mode | This servo amplifier is used as a position control servo. | |
| Speed control mode | This servo amplifier is used as a speed control servo. | |
| Torque control mode | This servo amplifier is used as a torque control servo. | |
| High-resolution encoder | High-resolution encoder of 4194304 pulses/rev is used as the encoder of the rotary servo motor compatible with the MELSERVO-J4 series. | |
| Absolute position detection system | Merely setting a home position once makes home position return unnecessary at every power-on. | Chapter 12 |
| Gain switching function | Using an input device or gain switching conditions (including the servo motor speed) switches gains. | Section 7.2 |
| Advanced vibration suppression control II | This function suppresses vibration at the arm end or residual vibration of the machine. | Section 7.1.5 |
| Machine resonance suppression filter | The machine resonance suppression filter is a filter function (notch filter) which decreases the gain of the specific frequency to suppress the resonance of the mechanical system. | Section 7.1.1 |
| Shaft resonance suppression filter | When a load is mounted to the servo motor shaft, resonance by shaft torsion during driving may generate a mechanical vibration at high frequency. The shaft resonance suppression filter suppresses the vibration. | Section 7.1.3 |
| Adaptive filter II | Servo amplifier detects mechanical resonance and sets filter characteristics automatically to suppress mechanical vibration. | Section 7.1.2 |
| Low-pass filter | Suppresses high-frequency resonance which occurs as servo system response is increased. | Section 7.1.4 |
| Machine analyzer function | Analyzes the frequency characteristic of the mechanical system by simply connecting an MR Configurator2 installed personal computer and servo amplifier. MR Configurator2 is necessary for this function. | |
| Robust filter | This function provides better disturbance response in case low response level that load to motor inertia ratio is high for such as roll send axes. | [Pr. PE41] |
| Slight vibration suppression control | Suppresses vibration of ± 1 pulse produced at a servo motor stop. | [Pr. PB24] |
| Auto tuning | Automatically adjusts the gain to optimum value if load applied to the servo motor shaft varies. | Chapter 6 |
| Regenerative option | Used when the built-in regenerative resistor of the servo amplifier does not have sufficient regenerative capability for the regenerative power generated. | Section 11.2 |
| Alarm history clear | Alarm history is cleared. | [Pr. PC21] |
| Output signal selection (Device settings) | The pins that output the output devices, including ALM (Malfunction) and INP (In-position), can be assigned to certain pins of the CN3 connectors. | [Pr. PD07] to [Pr. PD09] |
| Output signal (DO) forced output | Output signal can be forced on/off independently of the servo status. Use this function for output signal wiring check and others. | Section 4.5.1 (1) (d) |
| Test operation mode | Jog operation, positioning operation, motor-less operation, DO forced output, and program operation MR Configurator2 is necessary for this function. | Section 4.5 |
| MR Configurator2 | Using a personal computer, you can perform the parameter setting, test operation, monitoring, and others. | Section 11.4 |
| Linear servo system | Linear servo system can be configured using a linear servo motor and linear encoder. | Chapter 14 |
| Direct drive servo system | Direct drive servo system can be configured to drive a direct drive motor. | Chapter 15 |
| One-touch tuning | One click on a certain button on MR Configurator2 adjusts the gains of the servo amplifier. MR Configurator2 is necessary for this function. | Section 6.2 |

1. FUNCTIONS AND CONFIGURATION

| Function | Description | Detailed explanation |
|---------------------------------------------|---------------------------------------------------------------------------------------------------------------------------------------------------------------------------------------------------------------------------------------------------------------------------------------------------------------------------------------------------------------------------------------------------------------------------------------------------------------------------------------------------------------------------------------------------------------------------------------------------------------------------|-----------------------------------------------|
| SEMI-F47 function (Note) | Enables to avoid triggering [AL. 10 Undervoltage] using the electrical energy charged in the capacitor in case that an instantaneous power failure occurs during operation. Use a 3-phase for the input power supply of the servo amplifier. Using a 1-phase 200 V AC for the input power supply will not comply with the SEMI-F47 standard. | [Pr. PA20] [Pr. PE25] Section 7.4 |
| Tough drive function | This function makes the equipment continue operating even under the condition that an alarm occurs. The tough drive function includes two types: the vibration tough drive and the instantaneous power failure tough drive. | Section 7.3 |
| Drive recorder function | This function continuously monitors the servo status and records the status transition before and after an alarm for a fixed period of time. You can check the recorded data on the drive recorder window on MR Configurator2 by clicking the "Graph" button. However, the drive recorder will not operate on the following conditions. 1. You are using the graph function of MR Configurator2. 2. You are using the machine analyzer function. 3. [Pr. PF21] is set to "-1". 4. The controller is not connected (except the test operation mode). 5. An alarm related to the controller is occurring. | [Pr. PA23] |
| STO function | This function is a functional safety that complies with IEC/EN 61800-5-2. You can create a safety system for the equipment easily. | Chapter 13 |
| Servo amplifier life diagnosis function | You can check the cumulative energization time and the number of on/off times of the inrush relay. Before the parts of the servo amplifier, including a capacitor and relay, malfunction, this function is useful for finding out the time for their replacement. MR Configurator2 is necessary for this function. | |
| Power monitoring function | This function calculates the power running and the regenerative power from the data, including the speed and current, in the servo amplifier. MR Configurator2 can display the data, including the power consumption. Since the servo amplifier sends data to a servo system controller, you can analyze the data and display the data on a display with the SSCNET III/H system. | |
| Machine diagnostic function | From the data in the servo amplifier, this function estimates the friction and vibrational component of the drive system in the equipment and recognizes an error in the machine parts, including a ball screw and bearing. MR Configurator2 is necessary for this function. | |
| Fully closed loop system | Fully closed system can be configured using the load-side encoder. (not available with the MR-J4 3-axis servo amplifiers) This is used with servo amplifiers with software version A3 or later. Check the software version with MR Configurator2. | Chapter 16 |
| Scale measurement function | The function transmits position information of a scale measurement encoder to the controller by connecting the scale measurement encoder in semi closed loop control. Used by servo amplifiers with software version A8 or later. (not available with the MR-J4 3-axis servo amplifiers) | Section 17.2 |
| J3 compatibility mode | This amplifier has "J3 compatibility mode" which compatible with the previous MR-J3-B series. Refer to section 17.1 for software versions. | Section 17.1 |
| Continuous operation to torque control mode | This enables to smoothly switch the mode from position control mode/speed control mode to torque control mode without stopping. This also enables to decrease load to the machine and high quality molding without rapid changes in speed or torque. For details of the continuous operation to torque control mode, refer to the manuals for servo system controllers. | [Pr. PB03] Servo system controller manuals |

Note. For servo system controllers which are available with this, contact your local sales office.

1. FUNCTIONS AND CONFIGURATION

1.5 Model designation

(1) Rating plate

The following shows an example of rating plate for explanation of each item.

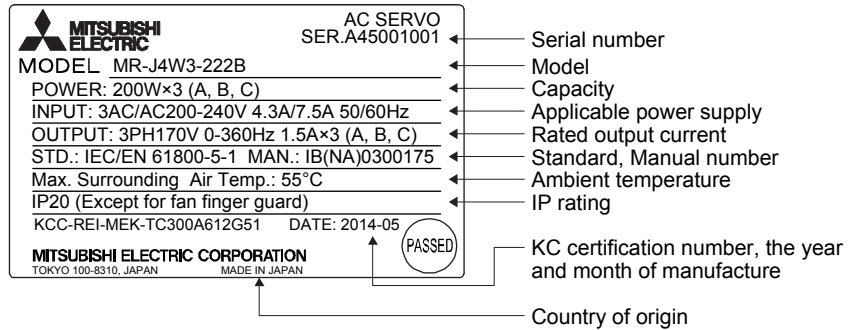

Note. Production year and month of the servo amplifier are indicated in a serial number on the rating plate.

The year and month of manufacture are indicated by the last one digit of the year and 1 to 9, X (10), Y (11), Z (12).

For September 2011, the Serial No. is like, "SERIAL: _ 19 _ _ _ _ _".

(2) Model

The following describes what each block of a model name indicates. Not all combinations of the symbols are available.

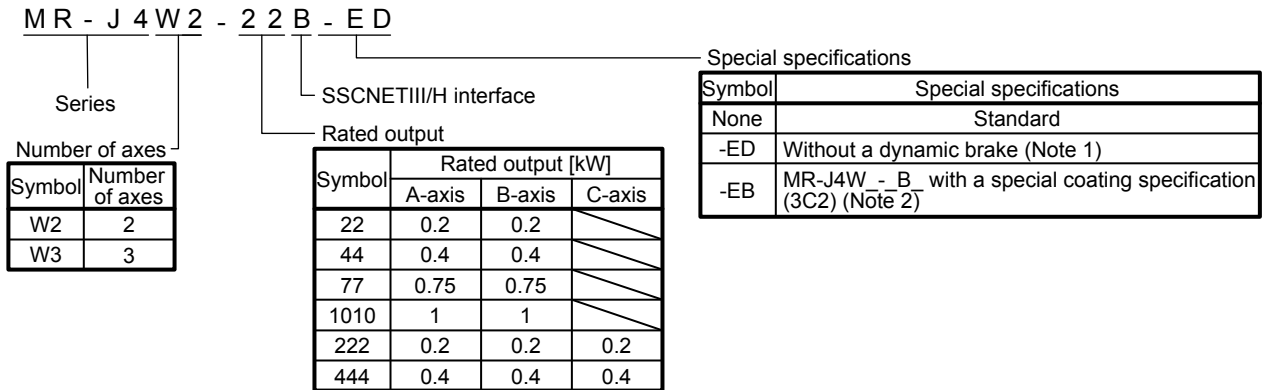

Note 1. Refer to App. 12.1 for details.

2. Type with a specially-coated servo amplifier board (IEC 60721-3-3 Class 3C2). Refer to app. 12.2 for details.

1. FUNCTIONS AND CONFIGURATION

1.6 Parts identification

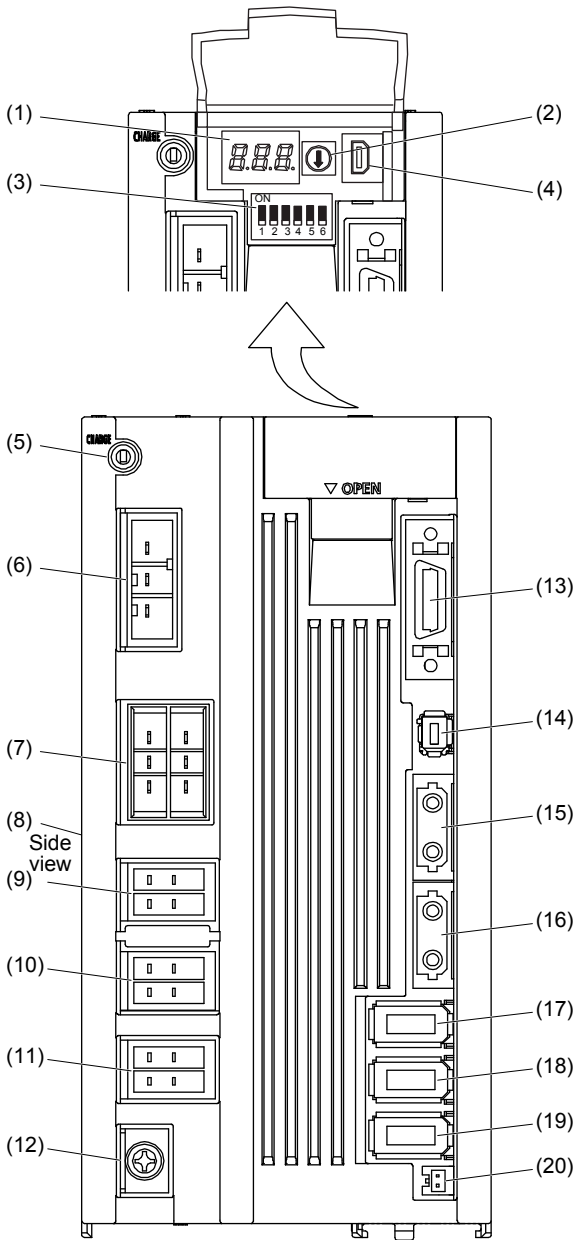

| No. | Name/Application | Detailed explanation |
|------------------|----------------------------------------------------------------------------------------------------------------------------------------------------------------|-------------------------------------------------------------------------------------------------|
| (1) | Display The 3-digit, 7-segment LED shows the servo status and the alarm number. | Section 4.3 |
| (2) | Axis selection rotary switch (SW1) Used to set the axis No. of servo amplifier. | |
| (3) | Control axis setting switch (SW2) The test operation switch, the disabling control axis switch, and the auxiliary axis number setting switch are available. | |
| (4) | USB communication connector (CN5) Connect with the personal computer. | Section 11.4 |
| (5) | Charge lamp Lit to indicate that the main circuit is charged. While this lamp is lit, do not reconnect the cables. | |
| (6) | Main circuit power connector (CNP1) Connect the input power supply. | Section 3.1 Section 3.3 |
| (7) | Control circuit power connector (CNP2) Connect the control circuit power supply or regenerative option. | |
| (8) | Rating plate | Section 1.5 |
| (9) | A-axis servo motor power connector (CNP3A) Connect the A-axis servo motor. | Section 3.1 Section 3.3 |
| (10) | B-axis servo motor power connector (CNP3B) Connect the B-axis servo motor. | |
| (11) | C-axis servo motor power connector (CNP3C) (Note 1) Connect the C-axis servo motor. | |
| (12) | Protective earth (PE) terminal | Section 3.11 |
| (13) | I/O signal connector (CN3) Used to connect digital I/O signals. | Section 3.2 Section 3.4 |
| (14) | STO input signal connector (CN8) Used to connect MR-J3-D05 safety logic unit and external safety relay. | Chapter 13 |
| (15) | SSCNET III cable connector (CN1A) Used to connect the servo system controller or the previous axis servo amplifier. | Section 3.2 Section 3.4 |
| (16) | SSCNET III cable connector (CN1B) Used to connect the next axis servo amplifier. For the final axis, put a cap. | |
| (17) (Note 2) | A-axis encoder connector (CN2A) Used to connect the A-axis servo motor encoder or external encoder. | Section 3.4 "Servo Motor Instruction Manual (Vol. 3)" "Linear Encoder Instruction Manual" |
| (18) (Note 2) | B-axis encoder connector (CN2B) Used to connect the B-axis servo motor encoder or external encoder. | |
| (19) (Note 2) | C-axis encoder connector (CN2C) (Note 1) Used to connect the C-axis servo motor encoder or linear encoder. | |
| (20) | Battery connector (CN4) Used to connect the battery unit for absolute position data backup. | Section 11.3 Chapter 12 |

- Note 1. This figure shows the MR-J4 3-axis servo amplifier.
- Note 2. "External encoder" is a term for linear encoder used in the linear servo system, load-side encoder used in the fully closed loop system, and scale measurement encoder used with the scale measurement function in this manual.

1. FUNCTIONS AND CONFIGURATION

1.7 Configuration including auxiliary equipment



● Connecting a servo motor for different axis to the CNP3A, CNP3B, or CNP3C connector may cause a malfunction.

POINT

● Equipment other than the servo amplifier and servo motor are optional or recommended products.

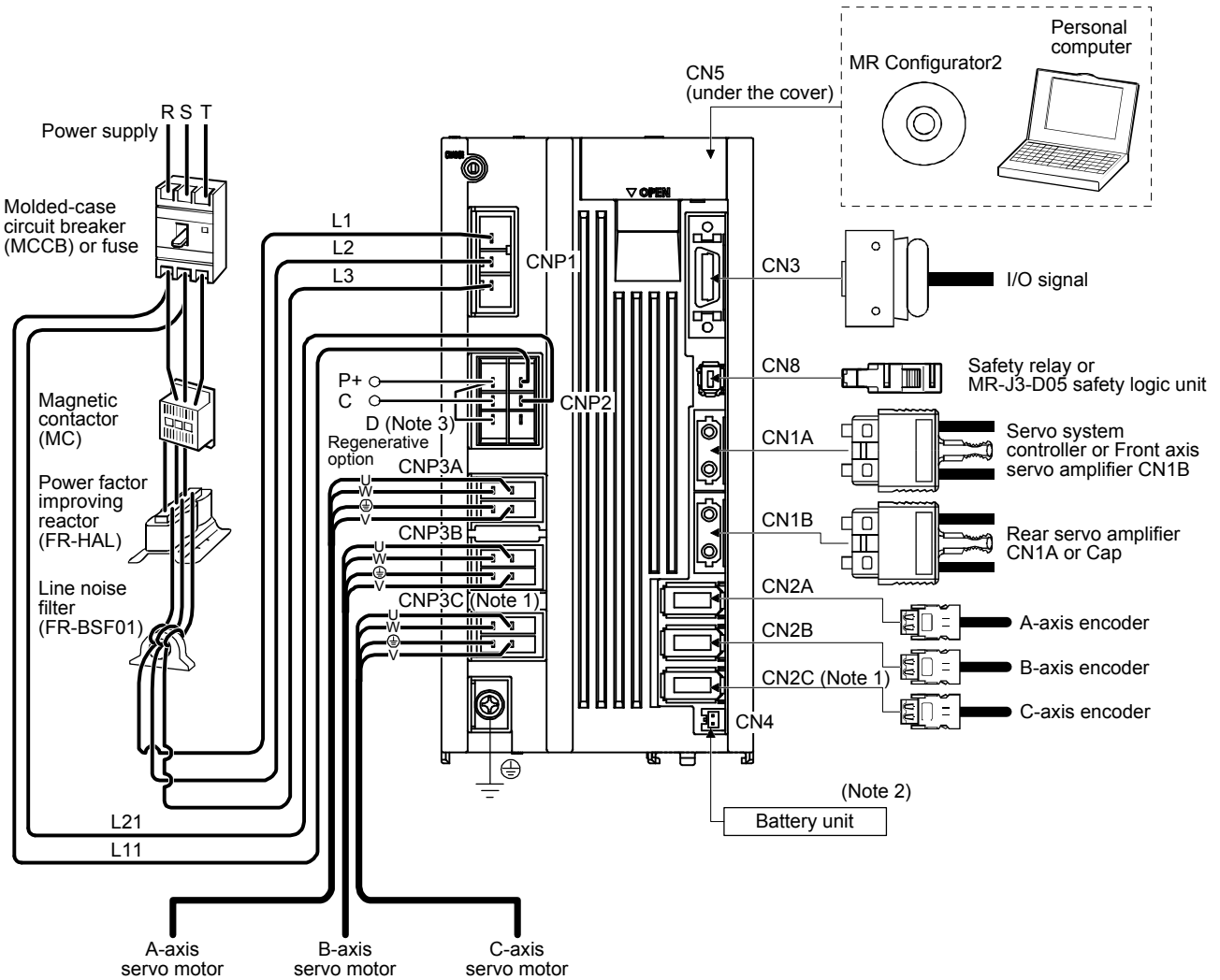

Note 1. For the MR-J4 3-axis servo amplifier

2. The battery unit consists of an MR-BT6VCASE battery case and five MR-BAT6V1 batteries. The battery unit is used in the absolute position detection system. (Refer to chapter 12.)

3. Always connect P+ and D. When using the regenerative option, refer to section 11.2.

2. INSTALLATION

2. INSTALLATION

 **WARNING** ● To prevent electric shock, ground each equipment securely.

 **CAUTION**

- Stacking in excess of the specified number of product packages is not allowed.
- Do not hold the cables, or connectors when carrying the servo amplifier. Otherwise, it may drop.
- Install the equipment on incombustible material. Installing it directly or close to combustibles will lead to a fire.
- Install the servo amplifier and the servo motor in a load-bearing place in accordance with the Instruction Manual.
- Do not get on or put heavy load on the equipment. Otherwise, it may cause injury.
- Use the equipment within the specified environmental range. For the environment, refer to section 1.3.
- Provide an adequate protection to prevent screws and other conductive matter, oil and other combustible matter from entering the servo amplifier.
- Do not block the intake and exhaust areas of the servo amplifier. Otherwise, it may cause a malfunction.
- Do not drop or apply heavy impact on the servo amplifiers and the servo motors. Otherwise, injury, malfunction, etc. may occur.
- Do not install or operate the servo amplifier which have been damaged or have any parts missing.
- When the product has been stored for an extended period of time, contact your local sales office.
- When handling the servo amplifier, be careful about the edged parts such as corners of the servo amplifier.
- The servo amplifier must be installed in the metal cabinet.
- When fumigants that contain halogen materials such as fluorine, chlorine, bromine, and iodine are used for disinfecting and protecting wooden packaging from insects, they cause malfunction when entering our products. Please take necessary precautions to ensure that remaining materials from fumigant do not enter our products, or treat packaging with methods other than fumigation (heat method). Additionally, disinfect and protect wood from insects before packing products.

2.1 Installation direction and clearances

 **CAUTION**

- The equipment must be installed in the specified direction. Otherwise, it may cause a malfunction.
- Leave specified clearances between the servo amplifier and the cabinet walls or other equipment. Otherwise, it may cause a malfunction.

When using heat generating equipment such as the regenerative option, install them with full consideration of heat generation so that the servo amplifier is not affected.

Install the servo amplifier on a perpendicular wall in the correct vertical direction.

2. INSTALLATION

(1) Installation of one servo amplifier

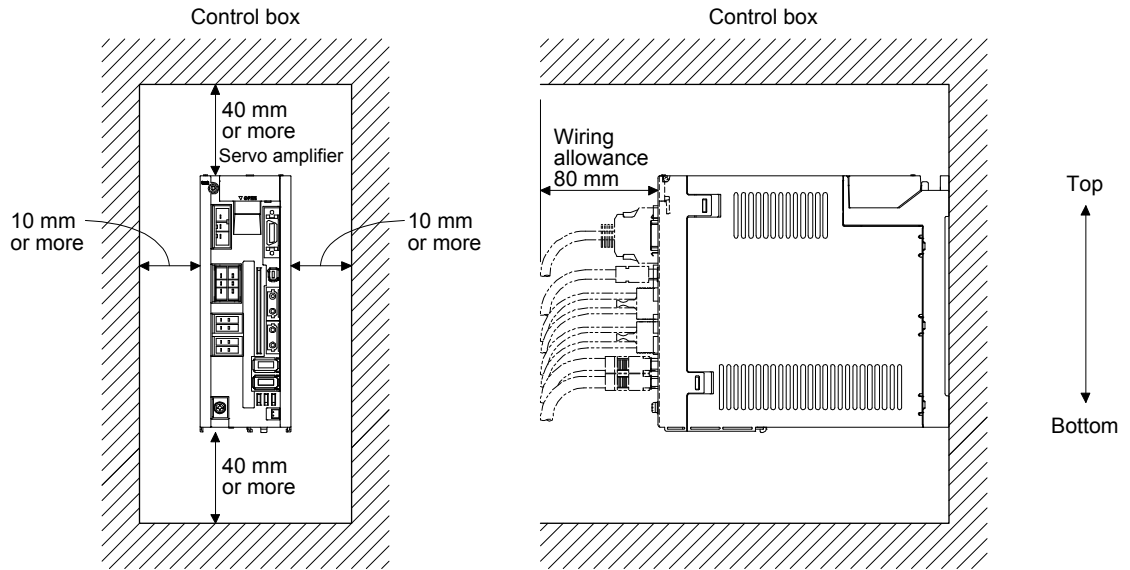

(2) Installation of two or more servo amplifiers

| POINT |
|-------------------------------------------------------------------------------|
| ● You can install MR-J4W_-B servo amplifiers without clearances between them. |

Leave a large clearance between the top of the servo amplifier and the cabinet walls, and install a cooling fan to prevent the internal temperature of the cabinet from exceeding the environment.

When mounting the servo amplifiers closely, leave a clearance of 1 mm between the adjacent servo amplifiers in consideration of mounting tolerances.

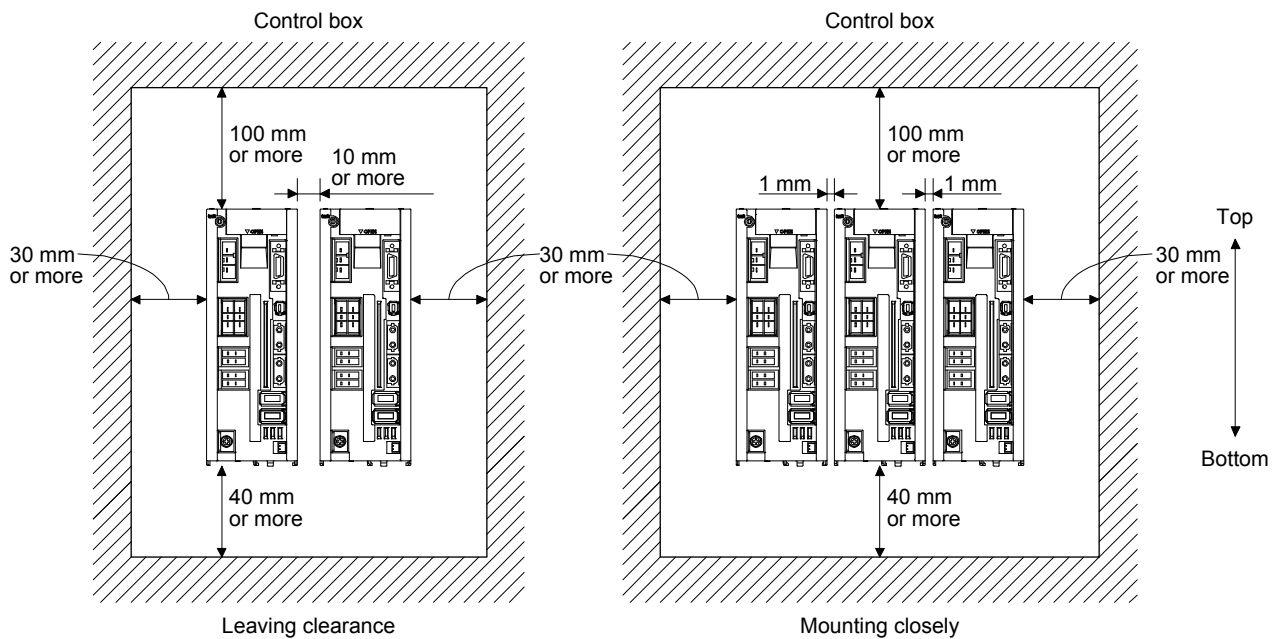

2. INSTALLATION

2.2 Keep out foreign materials

- (1) When drilling in the cabinet, prevent drill chips and wire fragments from entering the servo amplifier.
- (2) Prevent oil, water, metallic dust, etc. from entering the servo amplifier through openings in the cabinet or a cooling fan installed on the ceiling.
- (3) When installing the cabinet in a place where toxic gas, dirt and dust exist, conduct an air purge (force clean air into the cabinet from outside to make the internal pressure higher than the external pressure) to prevent such materials from entering the cabinet.

2.3 Encoder cable stress

- (1) The way of clamping the cable must be fully examined so that bending stress and cable's own weight stress are not applied to the cable connection.
- (2) For use in any application where the servo motor moves, fix the cables (for the encoder, power supply, and brake) with having some slack from the connector connection part of the servo motor to avoid putting stress on the connector connection part. Use the optional encoder cable within the bending life range. Use the power supply and brake wiring cables within the bending life of the cables.
- (3) Avoid any probability that the cable insulator might be cut by sharp chips, rubbed by a machine corner or stamped by workers or vehicles.
- (4) For the cable installation on a machine where the servo motor moves, the bending radius should be made as large as possible. Refer to section 10.4 for the bending life.

2.4 SSCNET III cable laying

SSCNET III cable is made from optical fiber. If optical fiber is added a power such as a major shock, lateral pressure, haul, sudden bending or twist, its inside distorts or breaks, and optical transmission will not be available. Especially, as optical fiber for MR-J3BUS_M/MR-J3BUS_M-A is made of synthetic resin, it melts down if being left near the fire or high temperature. Therefore, do not make it touched the part, which can become hot, such as heat sink or regenerative option of servo amplifier.

Read described item in this section carefully and handle it with caution.

(1) Minimum bend radius

Make sure to lay the cable with greater radius than the minimum bend radius. Do not press the cable to edges of equipment or others. For the SSCNET III cable, the appropriate length should be selected with due consideration for the dimensions and arrangement of the servo amplifier. When closing the door of cabinet, pay careful attention for avoiding the case that SSCNET III cable is held down by the door and the cable bend becomes smaller than the minimum bend radius. For the minimum bend radius, refer to section 11.1.2.

2. INSTALLATION

(2) Prohibition of vinyl tape use

Migrating plasticizer is used for vinyl tape. Keep the MR-J3BUS_M, and MR-J3BUS_M-A cables away from vinyl tape because the optical characteristic may be affected.

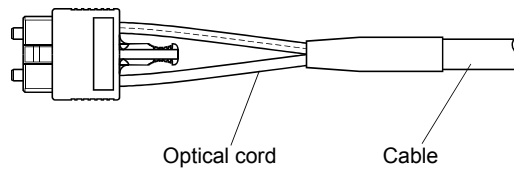

| SSCNET III cable | Cord | Cable |
|------------------|------|-------|
| MR-J3BUS_M | △ | △ |
| MR-J3BUS_M-A | △ | △ |
| MR-J3BUS_M-B | ○ | ○ |

△: Phthalate ester plasticizer such as DBP and DOP may affect optical characteristic of cable.

○: Cord and cable are not affected by plasticizer.

(3) Precautions for migrating plasticizer added materials

Generally, soft polyvinyl chloride (PVC), polyethylene resin (PE) and fluorine resin contain non-migrating plasticizer and they do not affect the optical characteristic of SSCNET III cable. However, some wire sheaths and cable ties, which contain migrating plasticizer (phthalate ester), may affect MR-J3BUS_M and MR-J3BUS_M-A cables.

In addition, MR-J3BUS_M-B cable is not affected by plasticizer.

A chemical substance may affect its optical characteristic. Therefore, previously check that the cable is not affected by the environment.

(4) Bundle fixing

Fix the cable at the closest part to the connector with bundle material in order to prevent SSCNET III cable from putting its own weight on CN1A/CN1B connector of servo amplifier. Optical cord should be given loose slack to avoid from becoming smaller than the minimum bend radius, and it should not be twisted.

When bundling the cable, fix and hold it in position by using cushioning such as sponge or rubber which does not contain migratable plasticizers.

If adhesive tape for bundling the cable is used, fire resistant acetate cloth adhesive tape 570F (Teraoka Seisakusho Co., Ltd) is recommended.

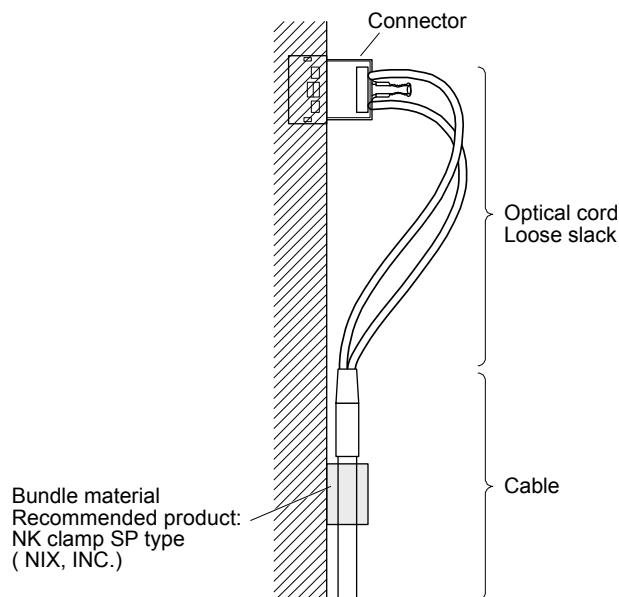

2. INSTALLATION

(5) Tension

If tension is added on optical cable, the increase of transmission loss occurs because of external force which concentrates on the fixing part of optical fiber or the connecting part of optical connector. Doing so may cause the breakage of the optical fiber or damage of the optical connector. For cable laying, handle without putting forced tension. For the tension strength, refer to section 11.1.2.

(6) Lateral pressure

If lateral pressure is added on optical cable, the optical cable itself distorts, internal optical fiber gets stressed, and then transmission loss will increase. Doing so may cause the breakage of the optical cable. As the same condition also occurs at cable laying, do not tighten up optical cable with a thing such as nylon band (TY-RAP).

Do not trample it down or tuck it down with the door of cabinet or others.

(7) Twisting

If optical fiber is twisted, it will become the same stress added condition as when local lateral pressure or bend is added. Consequently, transmission loss increases, and the breakage of optical fiber may occur.

(8) Disposal

When incinerating optical cable (cord) used for SSCNET III, hydrogen fluoride gas or hydrogen chloride gas which is corrosive and harmful may be generated. For disposal of optical fiber, request for specialized industrial waste disposal services who has incineration facility for disposing hydrogen fluoride gas or hydrogen chloride gas.

2.5 Inspection items

 **WARNING**

- Before starting maintenance and/or inspection, turn off the power and wait for 15 minutes or more until the charge lamp turns off. Then, confirm that the voltage between P+ and N- is safe with a voltage tester or others. Otherwise, an electric shock may occur. In addition, when confirming whether the charge lamp is off or not, always confirm it from the front of the servo amplifier.
- To avoid an electric shock, only qualified personnel should attempt inspections. For repair and parts replacement, contact your sales representative.

 **CAUTION**

- Do not perform insulation resistance test on the servo amplifier. Otherwise, it may cause a malfunction.
- Do not disassemble and/or repair the equipment on customer side.

It is recommended to make the following checks periodically.

- (1) Check for loose terminal block screws. Retighten any loose screws.
- (2) Check the cables and wires for scratches and cracks. Inspect them periodically according to operating conditions especially when the servo motor is movable.

2. INSTALLATION

- (3) Check that the connector is securely connected to the servo amplifier.
- (4) Check that the wires are not coming out from the connector.
- (5) Check for dust accumulation on the servo amplifier.
- (6) Check for unusual noise generated from the servo amplifier.
- (7) Make sure that the emergency stop circuit operates properly such that an operation can be stopped immediately and a power is shut off by the emergency stop switch.

2.6 Parts having service life

Service life of the following parts is listed below. However, the service life varies vary depending on operating methods and environmental conditions. If any fault is found in the parts, they must be replaced immediately regardless of their service life.

For parts replacement, please contact your sales representative.

| Part name | Life guideline |
|---------------------------|----------------------------------------------------------------------------------------------------------------------------------------------------------|
| Smoothing capacitor | 10 years |
| Relay | Number of power-on, forced stop by EM1 (Forced stop 1), and controller forced stop times: 100,000 times Number of on and off for STO: 1,000,000 times |
| Cooling fan | 50,000 hours to 70,000 hours (7 to 8 years) |
| Absolute position battery | Refer to section 12.2. |

(1) Smoothing capacitor

Affected by ripple currents, etc. and deteriorates in characteristic. The life of the capacitor greatly depends on ambient temperature and operating conditions. The capacitor will reach the end of its life in 10 years of continuous operation in air-conditioned environment (ambient temperature of 40 °C or less).

(2) Relays

Contact faults will occur due to contact wear arisen from switching currents. Relays reach the end of their life when the power has been turned on, forced stop by EM1 (Forced stop 1) has occurred, and controller forced stop has occurred 100,000 times in total, or when the STO has been turned on and off 1,000,000 times while the servo motor is stopped under servo-off state. However, the life of relays may depend on the power supply capacity.

(3) Servo amplifier cooling fan

The cooling fan bearings reach the end of their life in 50,000 hours to 70,000 hours. Normally, therefore, the fan must be changed in seven or eight years of continuous operation as a guideline.

If unusual noise or vibration is found during inspection, the cooling fan must also be replaced.

The life is under the environment where a yearly average ambient temperature of 40 °C, free from corrosive gas, flammable gas, oil mist, dust and dirt.

2. INSTALLATION

2.7 Restrictions when using this product at altitude exceeding 1000 m and up to 2000 m above sea level

(1) Effective load ratio and regenerative load ratio

As heat dissipation effects decrease in proportion to the decrease in air density, use the product within the effective load ratio and regenerative load ratio shown in the following figure.

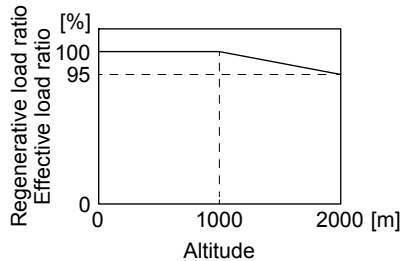

When closely mounting the servo amplifiers, operate them at the ambient temperature of 0 °C to 45 °C or at 75% or smaller effective load ratio. (Refer to section 2.1.)

(2) Input voltage

Generally, a withstand voltage decreases as increasing altitude; however, there is no restriction on the withstand voltage. Use in the same manner as in 1000 m or less. (Refer to section 1.3.)

(3) Parts having service life

(a) Smoothing capacitor

The capacitor will reach the end of its life in 10 years of continuous operation in air-conditioned environment (ambient temperature of 30 °C or less).

(b) Relay

There is no restriction. Use in the same manner as in 1000 m or less. (Refer to section 2.6.)

(c) Servo amplifier cooling fan

There is no restriction. Use in the same manner as in 1000 m or less. (Refer to section 2.6.)

3. SIGNALS AND WIRING

3. SIGNALS AND WIRING

⚠ WARNING

- Any person who is involved in wiring should be fully competent to do the work.
- Before wiring, turn off the power and wait for 15 minutes or more until the charge lamp turns off. Then, confirm that the voltage between P+ and N- is safe with a voltage tester and others. Otherwise, an electric shock may occur. In addition, when confirming whether the charge lamp is off or not, always confirm it from the front of the servo amplifier.
- Ground the servo amplifier and servo motor securely.
- Do not attempt to wire the servo amplifier and servo motor until they have been installed. Otherwise, it may cause an electric shock.
- The cables should not be damaged, stressed, loaded, or pinched. Otherwise, it may cause an electric shock.

- Wire the equipment correctly and securely. Otherwise, the servo motor may operate unexpectedly, resulting in injury.
- Connect cables to the correct terminals. Otherwise, a burst, damage, etc. may occur.
- Ensure that polarity (+/-) is correct. Otherwise, a burst, damage, etc. may occur.
- The surge absorbing diode installed to the DC relay for control output should be fitted in the specified direction. Otherwise, the emergency stop and other protective circuits may not operate.

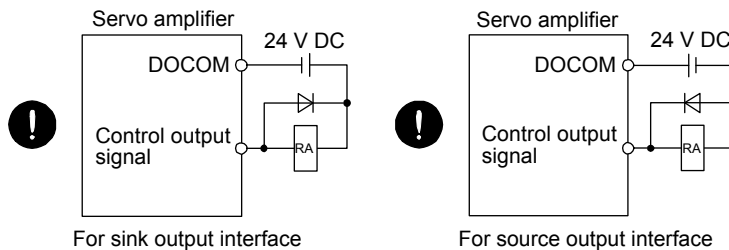

⚠ CAUTION

- Use a noise filter, etc. to minimize the influence of electromagnetic interference. Electromagnetic interference may be given to the electronic equipment used near the servo amplifier.
- Do not install a power capacitor, surge killer or radio noise filter (FR-BIF option) with the power line of the servo motor.
- When using the regenerative resistor, switch power off with the alarm signal. Otherwise, a transistor fault or the like may overheat the regenerative resistor, causing a fire.
- Do not modify the equipment.
- Connect the servo amplifier power output (U/V/W) to the servo motor power input (U/V/W) directly. Do not let a magnetic contactor, etc. intervene. Otherwise, it may cause a malfunction.

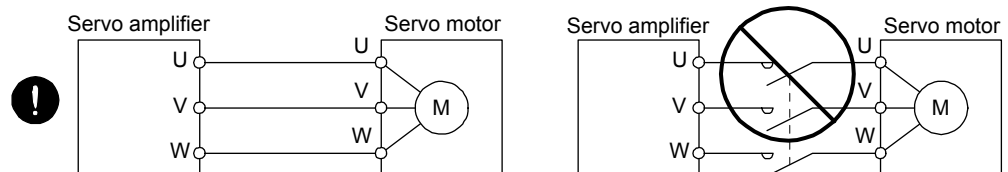

3. SIGNALS AND WIRING



- Connecting a servo motor for different axis to the CNP3A, CNP3B, or CN3C connector may cause a malfunction.
- Before wiring, switch operation, etc., eliminate static electricity. Otherwise, it may cause a malfunction.

POINT

- When you use a linear servo motor, replace the following words in the left to the words in the right.

| | | |
|-----------------------------|---|----------------------------|
| Load to motor inertia ratio | → | Load to motor mass ratio |
| Torque | → | thrust |
| (Servo motor) Speed | → | (Linear servo motor) Speed |

3.1 Input power supply circuit



- Always connect a magnetic contactor between the power supply and the main circuit power supply (L1/L2/L3) of the servo amplifier, in order to configure a circuit that shuts down the power supply on the side of the servo amplifier's power supply. If a magnetic contactor is not connected, continuous flow of a large current may cause a fire when the servo amplifier malfunctions.
- When alarms are occurring in all axes of A, B, and C, shut off the main circuit power supply. Not doing so may cause a fire when a regenerative transistor malfunctions or the like may overheat the regenerative resistor.
- Check the servo amplifier model, and then input proper voltage to the servo amplifier power supply. If input voltage exceeds the upper limit, the servo amplifier will break down.
- The servo amplifier has a built-in surge absorber (varistor) to reduce exogenous noise and to suppress lightning surge. Exogenous noise or lightning surge deteriorates the varistor characteristics, and the varistor may be damaged. To prevent a fire, use a molded-case circuit breaker or fuse for input power supply.
- Connecting a servo motor for different axis to the CNP3A, CNP3B, or CN3C connector may cause a malfunction.
- The N- terminal is not a neutral point of the power supply. Incorrect wiring will cause a burst, damage, etc.

POINT

- Even if alarm has occurred, do not switch off the control circuit power supply. When the control circuit power supply has been switched off, optical module does not operate, and optical transmission of SSCNET III/H communication is interrupted. Therefore, the next axis servo amplifier displays "AA" at the indicator and turns into base circuit shut-off. The servo motor stops with starting dynamic brake.
- EM2 has the same device as EM1 in the torque control mode.
- Connect the 1-phase 200 V AC to 240 V AC power supply to L1 and L3. One of the connecting destinations is different from MR-J3W Series Servo Amplifier. When using MR-J4W as a replacement for MR-J3W, be careful not to connect the power to L2.

3. SIGNALS AND WIRING

Configure the wiring so that the main circuit power supply is shut off and the servo-on command turned off after deceleration to a stop due to an alarm occurring, an enabled servo forced stop, or an enabled controller forced stop. A molded-case circuit breaker (MCCB) must be used with the input cables of the main circuit power supply.

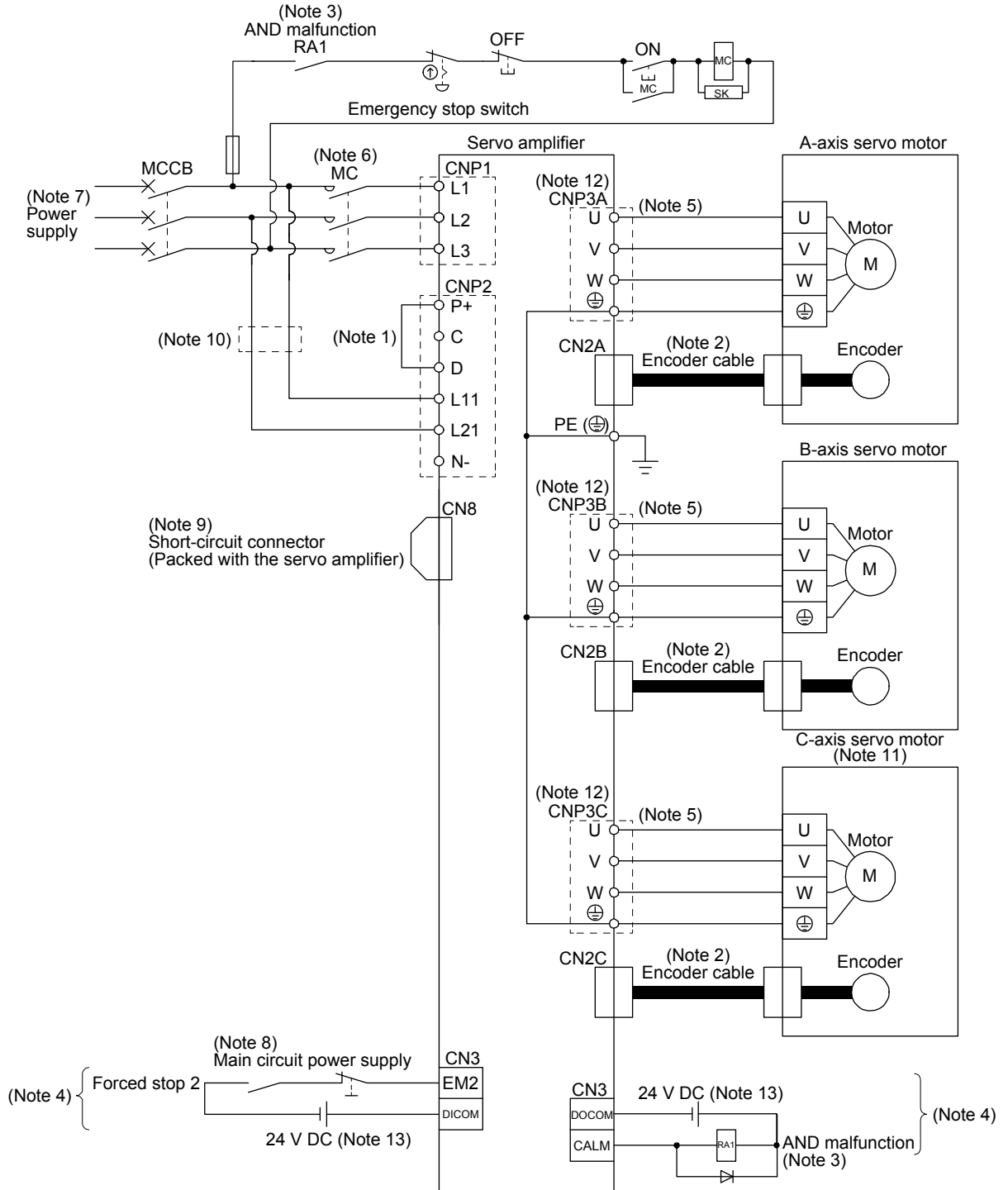

3. SIGNALS AND WIRING

- Note
1. Between P+ and D is connected by default. When using the regenerative option, refer to section 11.2.
 2. For the encoder cable, use of the option cable is recommended. For selecting cables, refer to Servo Motor Instruction Manual (Vol. 3).
 3. This circuit is an example of stopping all axes when an alarm occurs. If disabling CALM (AND malfunction) output with the parameter, configure up the power supply circuit which switches off the magnetic contactor after detection of alarm occurrence on the controller side.
 4. This diagram shows sink I/O interface. For source I/O interface, refer to section 3.8.3.
 5. For connecting servo motor power wires, refer to Servo Motor Instruction Manual (Vol. 3).
 6. Use a magnetic contactor with an operation delay time (interval between current being applied to the coil until closure of contacts) of 80 ms or less. Depending on the main circuit voltage and operation pattern, bus voltage decreases, and that may cause the forced stop deceleration to shift to the dynamic brake deceleration. When dynamic brake deceleration is not required, slow the time to turn off the magnetic contactor.
 7. For 1-phase 200 V AC to 240 V AC, connect the power supply to L1 and L3. Leave L2 open. For power supply specifications, refer to section 1.3.
 8. Configure up a circuit to turn off EM2 when the main circuit power is turned off to prevent an unexpected restart of the servo amplifier.
 9. When not using the STO function, attach a short-circuit connector supplied with a servo amplifier.
 10. When wires used for L11 and L21 are thinner than wires used for L1, L2, and L3, use a molded-case circuit breaker. (Refer to section 11.10.)
 11. For the MR-J4 3-axis servo amplifier
 12. Connecting a servo motor for different axis to the CNP3A, CNP3B, or CN3C connector may cause a malfunction.
 13. The illustration of the 24 V DC power supply is divided between input signal and output signal for convenience. However, they can be configured by one.

3. SIGNALS AND WIRING

3.2 I/O signal connection example

| |
|-------------------------------------------------------------|
| POINT |
| ●EM2 has the same device as EM1 in the torque control mode. |

3.2.1 For sink I/O interface

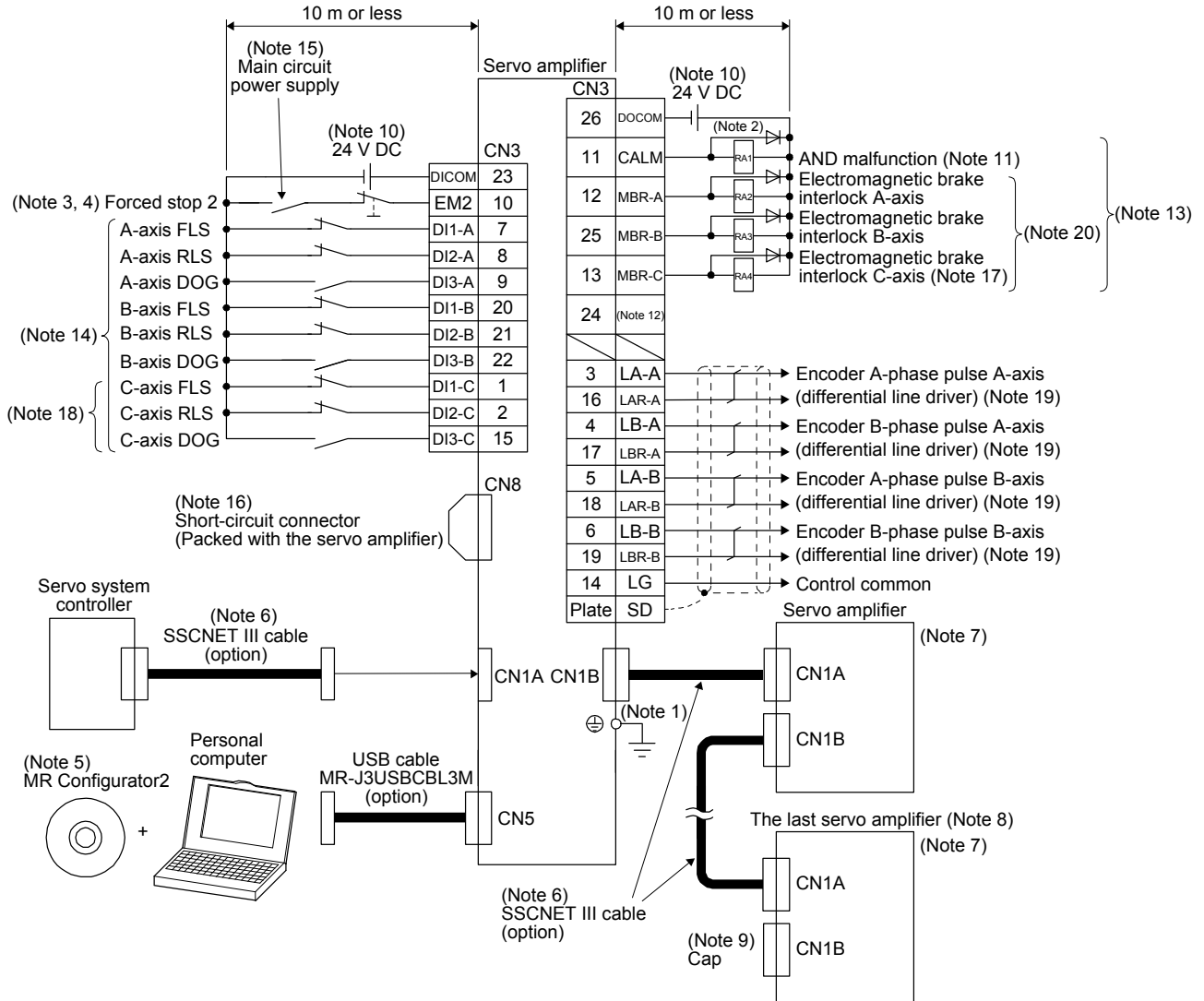

3. SIGNALS AND WIRING

- Note
1. To prevent an electric shock, always connect the protective earth (PE) terminal (marked ⊕) of the servo amplifier to the protective earth (PE) of the cabinet.
 2. Connect the diode in the correct direction. If it is connected reversely, the servo amplifier will malfunction and will not output signals, disabling EM2 (Forced stop 2) and other protective circuits.
 3. If the controller does not have forced stop function, always install the forced stop 2 switch (Normally closed contact).
 4. When starting operation, always turn on EM2 (Forced stop 2). (Normally closed contact)
 5. Use SW1DNC-MRC2-_. (Refer to section 11.4.)
 6. Use SSCNET III cables listed in the following table.

| Cable | Cable model | Cable length |
|------------------------------|--------------|---------------|
| Standard cord inside panel | MR-J3BUS_M | 0.15 m to 3 m |
| Standard cable outside panel | MR-J3BUS_M-A | 5 m to 20 m |
| Long-distance cable | MR-J3BUS_M-B | 30 m to 50 m |

7. The wiring after the second servo amplifier is omitted.
8. Up to 64 axes of servo amplifiers can be connected. The number of connectable axes depends on the controller you use. Refer to section 4.3 for setting of axis selection.
9. Make sure to cap the unused CN1B connector.
10. Supply 24 V DC \pm 10% for interfaces from outside. Set the total current capacity to 350 mA for MR-J4W2-_B and to 450 mA for MR-J4W3-_B. The 24 V DC power supply can be used both for input signals and output signals. 350 mA and 450 mA are the values applicable when all I/O signals are used. The current capacity can be decreased by reducing the number of I/O points. Refer to section 3.8.2 (1) that gives the current value necessary for the interface. The illustration of the 24 V DC power supply is divided between input signal and output signal for convenience. However, they can be configured by one.
11. CALM (AND malfunction) turns on in normal alarm-free condition. (Normally closed contact)
12. In the initial setting, CINP (AND in-position) is assigned to the pin. You can change devices of the pin with [Pr. PD08].
13. You can change devices of these pins with [Pr. PD07] and [Pr. PD09].
14. Devices can be assigned for these devices with controller setting. For devices that can be assigned, refer to the controller instruction manual. These assigned devices are for R_MTCPU, Q17_DSCPU, RD77MS_, QD77MS_, and LD77MS_.
15. Configure up a circuit to turn off EM2 when the main circuit power is turned off to prevent an unexpected restart of the servo amplifier.
16. When not using the STO function, attach a short-circuit connector supplied with a servo amplifier.
17. The pin is not used for MR-J4 2-axis servo amplifiers.
18. For the MR-J4 3-axis servo amplifier
19. This signal cannot be used for MR-J4W3-_B.
20. When you use a linear servo motor or direct drive motor, use MBR (Electromagnetic brake interlock) for an external brake mechanism.

3. SIGNALS AND WIRING

3.2.2 For source I/O interface

POINT
 ● For notes, refer to section 3.2.1.

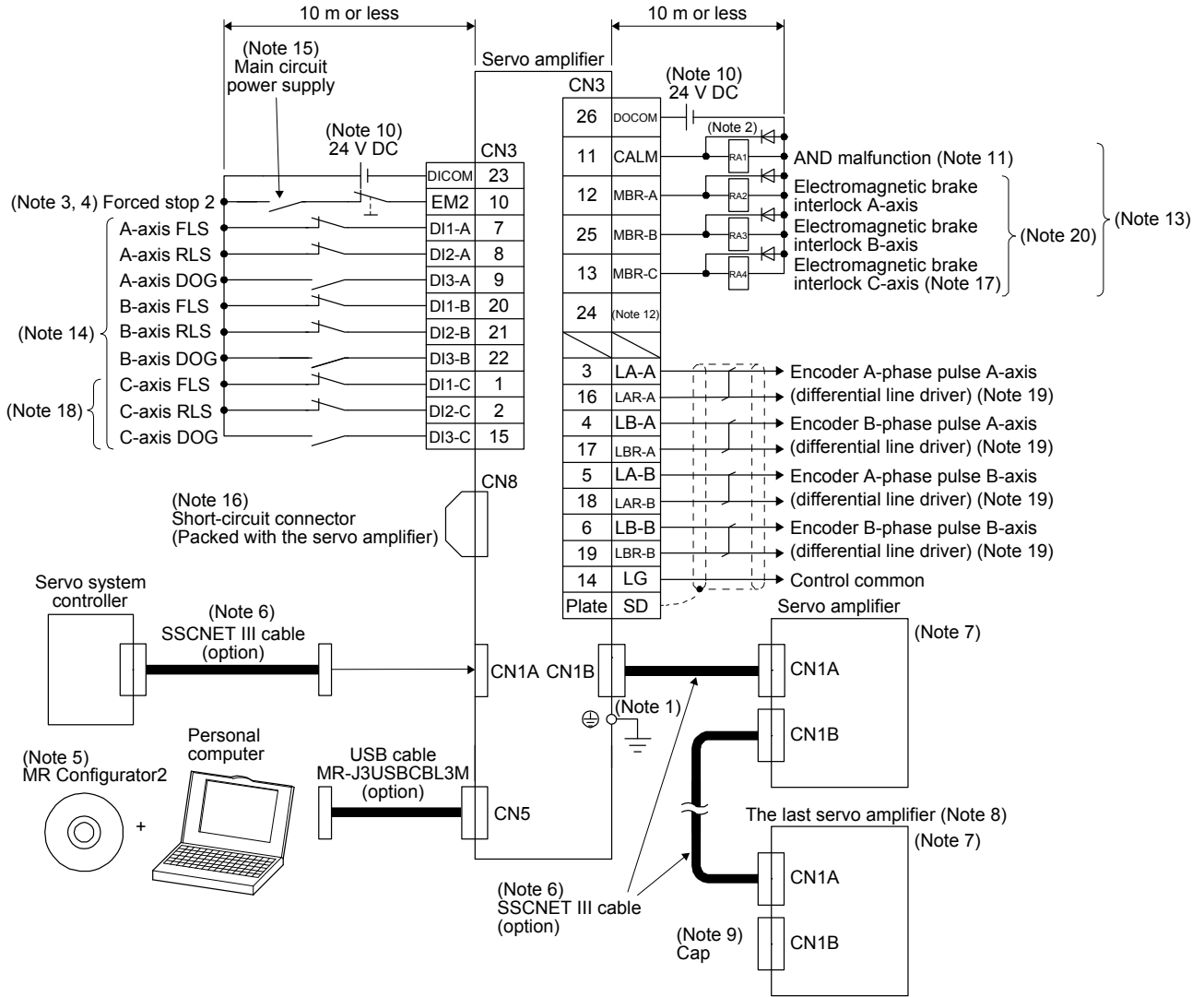

3. SIGNALS AND WIRING

3.3 Explanation of power supply system

3.3.1 Signal explanations

POINT

●N- terminal is for manufacturer. Be sure to leave this terminal open.

(1) Pin assignment and connector applications

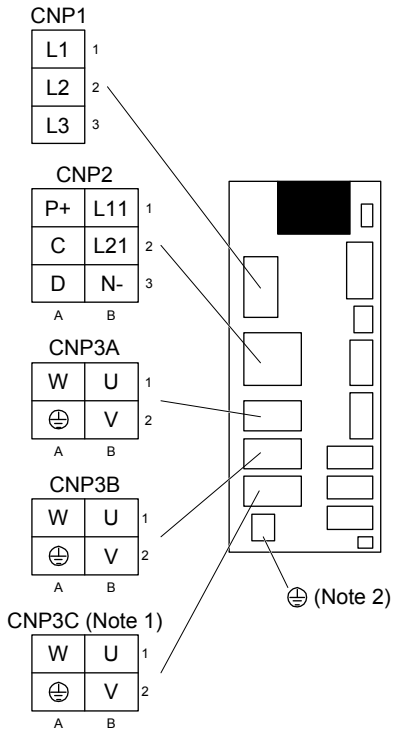

| Connector | Name | Function and application |
|----------------|------------------------------------|------------------------------------------------------------------|
| CNP1 | Main circuit power connector | Input main circuit power supply. |
| CNP2 | Control circuit power connector | Input control circuit power supply. Connect regenerative option. |
| CNP3A | A-axis servo motor power connector | Connect with the A-axis servo motor. |
| CNP3B | B-axis servo motor power connector | Connect with the B-axis servo motor. |
| CNP3C (Note 1) | C-axis servo motor power connector | Connect with the C-axis servo motor. |

Note 1. For the MR-J4 3-axis servo amplifier
 2. Connect to the protective earth (PE) of the cabinet to ground.

3. SIGNALS AND WIRING

(2) Detailed explanation

| Symbol | Connector | Connection destination (application) | Description | | | | | | | | | | | | | | | |
|-------------------------------------------|-------------------------|---------------------------------------------------------------------------|------------------------------------------------------------------------------------------------------------------------------------------------------------------------------------------------------------------------------------------------------------------------------------------------------------------------------------------------------------------------------------------------------------------------------------------------------------------------------------------------------------------------------------------------------------------------------------------------------------------|--------------|-----------------|---------------------------------------------------------------------------|---------------|--|-------------------------------------------|--|-------------------------------------------|--|----------|--|-------------------------------------------|--|-------|--|
| L1/L2/L3 | CNP1 | Main circuit power supply | <p>Supply the following power to L1, L2, and L3. For 1-phase 200 V AC to 240 V AC, connect the power supply to L1 and L3. Leave L2 open.</p> <table border="1"> <tr> <td rowspan="2">Power supply</td> <td>Servo amplifier</td> <td>MR-J4W2-22B MR-J4W2-44B MR-J4W2-77B MR-J4W3-222B MR-J4W3-444B</td> <td>MR-J4W2-1010B</td> </tr> <tr> <td></td> <td></td> <td></td> </tr> <tr> <td colspan="2">3-phase 200 V AC to 240 V AC, 50 Hz/60 Hz</td> <td colspan="2">L1/L2/L3</td> </tr> <tr> <td colspan="2">1-phase 200 V AC to 240 V AC, 50 Hz/60 Hz</td> <td>L1/L3</td> <td></td> </tr> </table> | Power supply | Servo amplifier | MR-J4W2-22B MR-J4W2-44B MR-J4W2-77B MR-J4W3-222B MR-J4W3-444B | MR-J4W2-1010B | | | | 3-phase 200 V AC to 240 V AC, 50 Hz/60 Hz | | L1/L2/L3 | | 1-phase 200 V AC to 240 V AC, 50 Hz/60 Hz | | L1/L3 | |
| Power supply | Servo amplifier | MR-J4W2-22B MR-J4W2-44B MR-J4W2-77B MR-J4W3-222B MR-J4W3-444B | MR-J4W2-1010B | | | | | | | | | | | | | | | |
| | | | | | | | | | | | | | | | | | | |
| 3-phase 200 V AC to 240 V AC, 50 Hz/60 Hz | | L1/L2/L3 | | | | | | | | | | | | | | | | |
| 1-phase 200 V AC to 240 V AC, 50 Hz/60 Hz | | L1/L3 | | | | | | | | | | | | | | | | |
| P+/C/D | CNP2 | Regenerative option | When using a servo amplifier built-in regenerative resistor, connect P+ and D. (factory-wired) When using a regenerative option, connect the regenerative option to P+ and C. Refer to section 11.2 for details. | | | | | | | | | | | | | | | |
| N- | | For manufacturer | N- terminal is for manufacturer. Be sure to leave this terminal open. | | | | | | | | | | | | | | | |
| L11/L21 | | Control circuit power supply | <p>Supply the following power to L11 and L21.</p> <table border="1"> <tr> <td rowspan="2">Power supply</td> <td>Servo amplifier</td> <td>MR-J4W2-22B to MR-J4W2-1010B MR-J4W3-222B to MR-J4W3-444B</td> </tr> <tr> <td></td> <td></td> </tr> <tr> <td colspan="2">1-phase 200 V AC to 240 V AC, 50 Hz/60 Hz</td> <td>L11/L21</td> </tr> </table> | Power supply | Servo amplifier | MR-J4W2-22B to MR-J4W2-1010B MR-J4W3-222B to MR-J4W3-444B | | | 1-phase 200 V AC to 240 V AC, 50 Hz/60 Hz | | L11/L21 | | | | | | | |
| Power supply | Servo amplifier | MR-J4W2-22B to MR-J4W2-1010B MR-J4W3-222B to MR-J4W3-444B | | | | | | | | | | | | | | | | |
| | | | | | | | | | | | | | | | | | | |
| 1-phase 200 V AC to 240 V AC, 50 Hz/60 Hz | | L11/L21 | | | | | | | | | | | | | | | | |
| U/V/W | CNP3A CNP3B CNP3C | Servo motor power output | Connect them to the servo motor power supply (U/V/W). Connect the servo amplifier power output (U/V/W) to the servo motor power input (U/V/W) directly. Do not let a magnetic contactor, etc. intervene. Otherwise, it may cause a malfunction. | | | | | | | | | | | | | | | |
| ⊕ (Note 2) | (Note 1) | Protective earth (PE) | Connect the grounding terminal of the servo motor. | | | | | | | | | | | | | | | |
| ⊕ (Note 2) | | Protective earth (PE) | Connect to the protective earth (PE) of the cabinet to ground. | | | | | | | | | | | | | | | |

Note 1. For the MR-J4 3-axis servo amplifier

2. Connect the grounding terminal of the servo motor to ⊕ of CNP3A, CNP3B, and CNP3C. For grounding, connect the protective earth (PE) terminal (⊕) of front lower part on the servo amplifier to the protective earth (PE) terminal on a cabinet.

3. SIGNALS AND WIRING

3.3.2 Power-on sequence

| |
|--------------------------------------------------------|
| POINT |
| ● An output signal, etc. may be irregular at power-on. |

(1) Power-on procedure

- 1) Always wire the power supply as shown in above section 3.1 using the magnetic contactor with the main circuit power supply ((L1/L2/L3)). Configure up an external sequence to switch off the magnetic contactor as soon as an alarm occurs in all axes of A, B, and C.
- 2) Switch on the control circuit power supply (L11/L21) simultaneously with the main circuit power supply or before switching on the main circuit power supply. If the control circuit power supply is turned on with the main circuit power supply off, and then the servo-on command is transmitted, [AL. E9 Main circuit off warning] will occur. Turning on the main circuit power supply stops the warning and starts the normal operation.
- 3) The servo amplifier receives the servo-on command within 4 s after the main circuit power supply is switched on.
(Refer to (2) in this section.)

(2) Timing chart

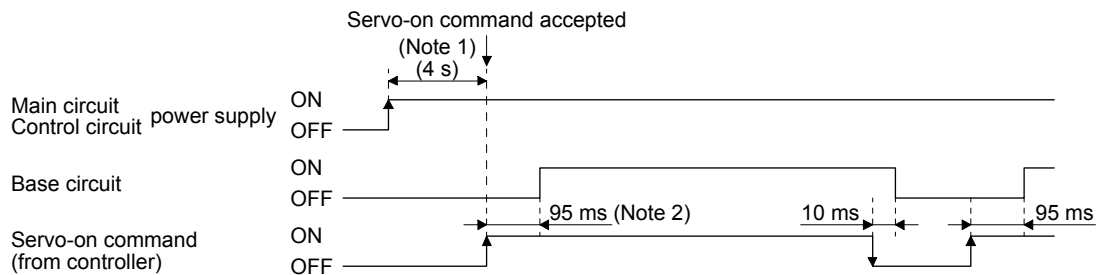

- Note 1. This range will be approximately 6 s for the linear servo system and fully closed loop system.
 Note 2. The time will be longer during the magnetic pole detection of a linear servo motor and direct drive motor.

3. SIGNALS AND WIRING

3.3.3 Wiring CNP1, CNP2, and CNP3

| POINT |
|----------------------------------------------------------------------------------------------------------------------------------------------------------------------------------------------------------------------------------------------------------------------|
| <ul style="list-style-type: none"> ● For the wire sizes used for wiring, refer to section 11.5. ● When wiring, remove the power connectors from the servo amplifier. ● Insert only one wire or ferrule to each wire insertion hole. |

(1) Connector

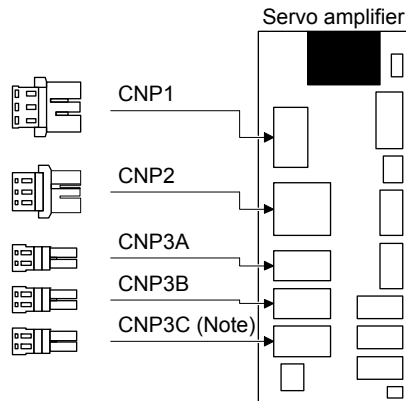

Note. For the MR-J4 3-axis servo amplifier

Table 3.1 Connector and applicable wire

| Connector | Receptacle assembly | Applicable wire size | Stripped length [mm] | Open tool | Manufacturer |
|-------------------------|---------------------|----------------------|----------------------|--------------------------------|--------------|
| CNP1 | 03JFAT-SAXGFK-43 | AWG 16 to 14 | 11.5 | J-FAT-OT-EXL (big size side) | JST |
| CNP2 | 06JFAT-SAXYGG-F-KK | AWG 16 to 14 | 9 | J-FAT-OT-EXL (small size side) | |
| CNP3A CNP3B CNP3C | 04JFAT-SAGG-G-KK | AWG 18 to 14 | 9 | J-FAT-OT-EXL (small size side) | |

3. SIGNALS AND WIRING

(2) Cable connection procedure

(a) Cable making

Refer to table 3.1 for stripped length of cable insulator. The appropriate stripped length of cables depends on their type, etc. Set the length considering their status.

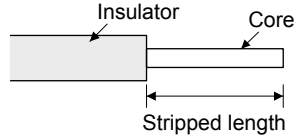

Twist strands slightly and straighten them as follows.

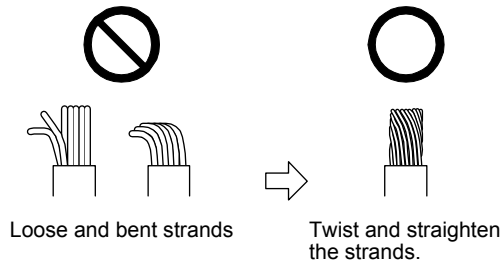

You can also use a ferrule to connect with the connectors. When you use a ferrule, use the following ferrules and crimp terminal.

| Wire size | Ferrule model (Phoenix contact) | | Crimping tool (Phoenix contact) |
|-----------|---------------------------------|-------------------|------------------------------------|
| | For 1 wire | For 2 wires | |
| AWG 16 | AI1.5-10BK | AI-TWIN2×1.5-10BK | CRIMPFOX-ZA3 |
| AWG 14 | AI2.5-10BU | | |

(b) Inserting wire

Insert only one wire or ferrule to each wire insertion hole.

Insert the open tool as follows and push it down to open the spring. While the open tool is pushed down, insert the stripped wire into the wire insertion hole. Check the wire insertion depth, and make sure that the cable insulator will not be caught by the spring and that the conductive part of the stripped wire will not be exposed.

Release the open tool to fix the wire. Pull the wire lightly to confirm that the wire is surely connected. In addition, make sure that no conductor wire sticks out of the connector.

The following shows a connection example of the CNP1 connector.

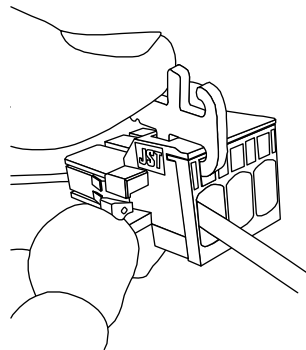

3. SIGNALS AND WIRING

3.4 Connectors and pin assignment

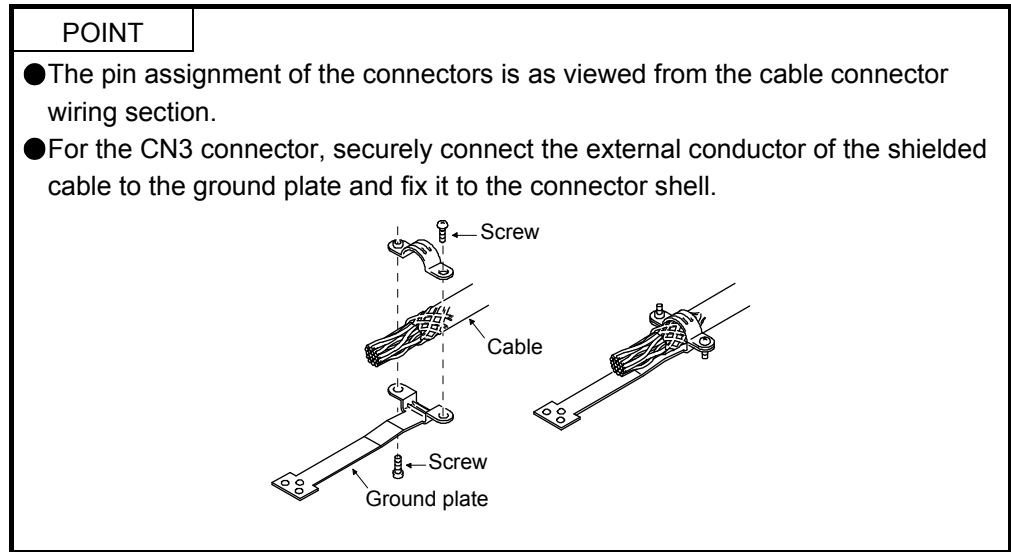

The frames of the CN2A, CN2B, CN2C and CN3 connectors are connected to the protective earth terminal in the servo amplifier.

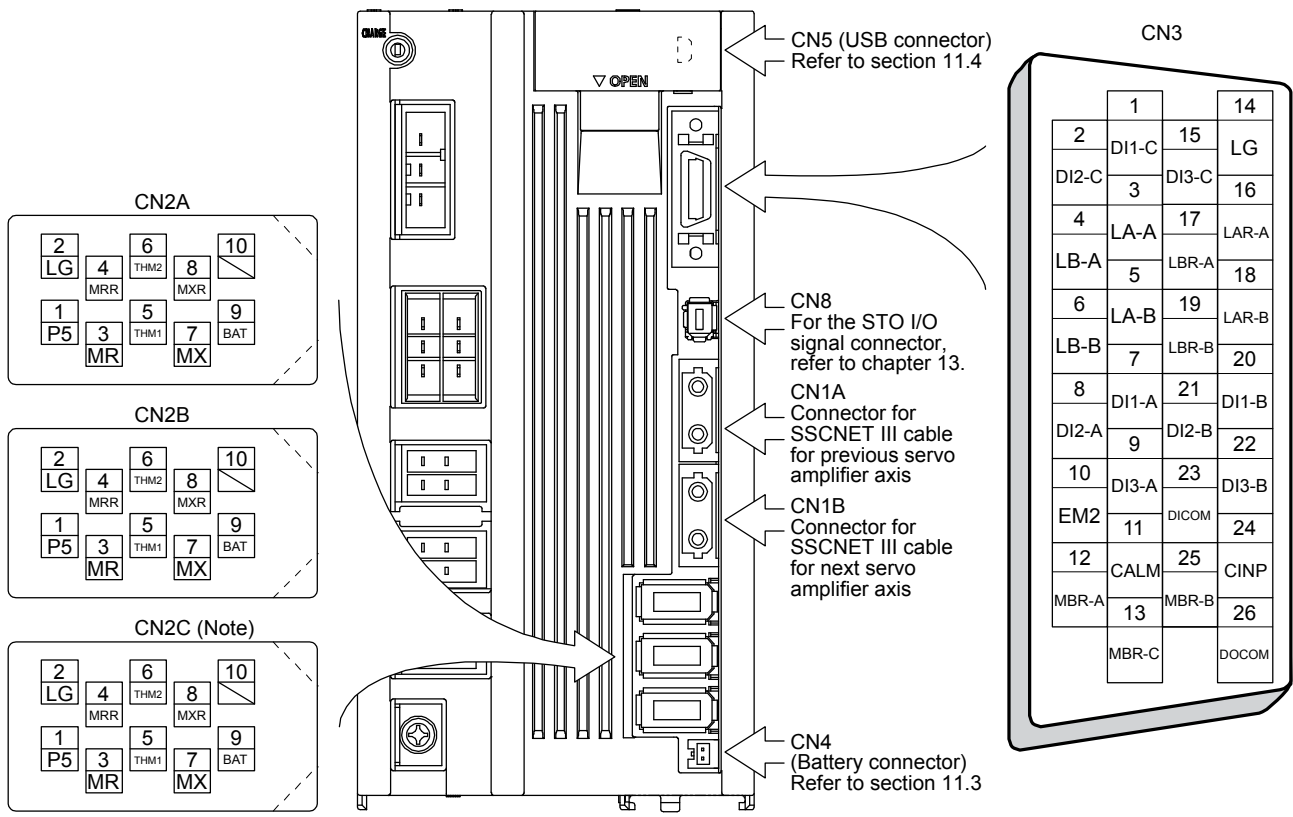

The 3M make connector is shown.

Note. For the MR-J4 3-axis servo amplifier

3. SIGNALS AND WIRING

3.5 Signal (device) explanations

For the I/O interfaces (symbols in I/O division column in the table), refer to section 3.8.

The pin numbers in the connector pin No. column are those in the initial status.

3.5.1 Input device

| Device | Symbol | Connector pin No. | Function and application | I/O division | | | | | | | | | | | | | | | | | | | | | | |
|------------------------------------------------------------|-----------------------|-------------------|------------------------------------------------------------------------------------------------------------------------------------------------------------------------------------------------------------------------------------------------------------------------------------------------------------------------------------------------------------------------------------------------------------------------------------------------------------------------------------------------------------------------------------------------------------------------------------------------------------------------------------------------------------------------------------------------------------------------------------------------------------------------------------------------------------------------------------------------------------------------------------------------------------------------------------------------------------------------------------------------------------------------------------------------------------------------------------------------------------------------------------------------------------------------------------------------------------------------------------------------------------------------------------------------------------------------------------------------------------------------------------------------------------------------------------|--------------------|---------------------------------------------------------------------------------------|---------------------------------------------------------------------------------------|---------------------|-------------------|----------------|---------|-----|---------------------------------------------------------------------------------------|---------------------------------------------------------------------------------------|---------|-----|-------------------------------------------------------------------------------------|-------------------------------------------------------------------------------------|---------|-----------------------|---|---------------------------------------------------------------------------------------|---------|-----------------------|---|-------------------------------------------------------------------------------------|------|
| Forced stop 2 | EM2 | (CN3-10) | <p>Turn off EM2 (open between commons) to decelerate the servo motor to a stop with commands.</p> <p>Turn EM2 on (short between commons) in the forced stop state to reset that state.</p> <p>Set [Pr. PA04] to "2 1 _ _" to disable EM2.</p> <p>The following shows the setting of [Pr. PA04].</p> <table border="1"> <thead> <tr> <th rowspan="2">[Pr. PA04] setting</th> <th rowspan="2">EM2/EM1</th> <th colspan="2">Deceleration method</th> </tr> <tr> <th>EM2 or EM1 is off</th> <th>Alarm occurred</th> </tr> </thead> <tbody> <tr> <td>0 0 _ _</td> <td>EM1</td> <td>MBR (Electromagnetic brake interlock) turns off without the forced stop deceleration.</td> <td>MBR (Electromagnetic brake interlock) turns off without the forced stop deceleration.</td> </tr> <tr> <td>2 0 _ _</td> <td>EM2</td> <td>MBR (Electromagnetic brake interlock) turns off after the forced stop deceleration.</td> <td>MBR (Electromagnetic brake interlock) turns off after the forced stop deceleration.</td> </tr> <tr> <td>0 1 _ _</td> <td>Not using EM2 and EM1</td> <td style="text-align: center;">/</td> <td>MBR (Electromagnetic brake interlock) turns off without the forced stop deceleration.</td> </tr> <tr> <td>2 1 _ _</td> <td>Not using EM2 and EM1</td> <td style="text-align: center;">/</td> <td>MBR (Electromagnetic brake interlock) turns off after the forced stop deceleration.</td> </tr> </tbody> </table> | [Pr. PA04] setting | EM2/EM1 | Deceleration method | | EM2 or EM1 is off | Alarm occurred | 0 0 _ _ | EM1 | MBR (Electromagnetic brake interlock) turns off without the forced stop deceleration. | MBR (Electromagnetic brake interlock) turns off without the forced stop deceleration. | 2 0 _ _ | EM2 | MBR (Electromagnetic brake interlock) turns off after the forced stop deceleration. | MBR (Electromagnetic brake interlock) turns off after the forced stop deceleration. | 0 1 _ _ | Not using EM2 and EM1 | / | MBR (Electromagnetic brake interlock) turns off without the forced stop deceleration. | 2 1 _ _ | Not using EM2 and EM1 | / | MBR (Electromagnetic brake interlock) turns off after the forced stop deceleration. | DI-1 |
| | | | [Pr. PA04] setting | | | EM2/EM1 | Deceleration method | | | | | | | | | | | | | | | | | | | |
| | | | | EM2 or EM1 is off | Alarm occurred | | | | | | | | | | | | | | | | | | | | | |
| | | | 0 0 _ _ | EM1 | MBR (Electromagnetic brake interlock) turns off without the forced stop deceleration. | MBR (Electromagnetic brake interlock) turns off without the forced stop deceleration. | | | | | | | | | | | | | | | | | | | | |
| | | | 2 0 _ _ | EM2 | MBR (Electromagnetic brake interlock) turns off after the forced stop deceleration. | MBR (Electromagnetic brake interlock) turns off after the forced stop deceleration. | | | | | | | | | | | | | | | | | | | | |
| 0 1 _ _ | Not using EM2 and EM1 | / | MBR (Electromagnetic brake interlock) turns off without the forced stop deceleration. | | | | | | | | | | | | | | | | | | | | | | | |
| 2 1 _ _ | Not using EM2 and EM1 | / | MBR (Electromagnetic brake interlock) turns off after the forced stop deceleration. | | | | | | | | | | | | | | | | | | | | | | | |
| EM2 and EM1 are mutually exclusive. | | | | | | | | | | | | | | | | | | | | | | | | | | |
| EM2 has the same device as EM1 in the torque control mode. | | | | | | | | | | | | | | | | | | | | | | | | | | |
| | | | | | | | | | | | | | | | | | | | | | | | | | | |
| | | | | | | | | | | | | | | | | | | | | | | | | | | |
| Forced stop 1 | EM1 | (CN3-10) | <p>When using EM1, set [Pr. PA04] to "0 0 _ _" to enable EM1.</p> <p>When EM1 is turned off (open between commons), the base circuit shuts off, and the dynamic brake operates to decelerate the servo motor to a stop.</p> <p>The forced stop will be reset when EM1 is turned on (short between commons).</p> <p>Set [Pr. PA04] to "0 1 _ _" to disable EM1.</p> | DI-1 | | | | | | | | | | | | | | | | | | | | | | |
| / | DI1-A | CN3-7 | <p>Devices can be assigned for these devices with controller setting. For devices that can be assigned, refer to the controller instruction manual. You can assign the following devices with MR-J4 series compatible controllers (R_MTCPU, Q17_DSCPU, RD77MS_, and QD77MS_)</p> <p>DI1-A: FLS for A-axis (Upper stroke limit)</p> <p>DI2-A: RLS for A-axis (Lower stroke limit)</p> <p>DI3-A: DOG for A-axis (Proximity dog)</p> <p>DI1-B: FLS for B-axis (Upper stroke limit)</p> <p>DI2-B: RLS for B-axis (Lower stroke limit)</p> <p>DI3-B: DOG for B-axis (Proximity dog)</p> <p>DI1-C: FLS for C-axis (Upper stroke limit)</p> <p>DI2-C: RLS for C-axis (Lower stroke limit)</p> <p>DI3-C: DOG for C-axis (Proximity dog)</p> | DI-1 | | | | | | | | | | | | | | | | | | | | | | |
| | DI2-A | CN3-8 | | DI-1 | | | | | | | | | | | | | | | | | | | | | | |
| | DI3-A | CN3-9 | | DI-1 | | | | | | | | | | | | | | | | | | | | | | |
| | DI1-B | CN3-20 | | DI-1 | | | | | | | | | | | | | | | | | | | | | | |
| | DI2-B | CN3-21 | | DI-1 | | | | | | | | | | | | | | | | | | | | | | |
| | DI3-B | CN3-22 | | DI-1 | | | | | | | | | | | | | | | | | | | | | | |
| | DI1-C | CN3-1 | | DI-1 | | | | | | | | | | | | | | | | | | | | | | |
| | DI2-C | CN3-2 | | DI-1 | | | | | | | | | | | | | | | | | | | | | | |
| | DI3-C | CN3-15 | | DI-1 | | | | | | | | | | | | | | | | | | | | | | |

3. SIGNALS AND WIRING

3.5.2 Output device

(1) Output device pin

The following shows the output device pins and parameters for assigning devices.

| Connector pin No. | Parameter | | | Initial device | I/O division | Remark |
|-------------------|------------|------------|------------|----------------|--------------|-------------------|
| | A-axis | B-axis | C-axis | | | |
| CN3-12 | [Pr. PD07] | | | MBR-A | DO-1 | For A-axis |
| CN3-25 | | [Pr. PD07] | | MBR-B | | For B-axis |
| CN3-13 | | | [Pr. PD07] | MBR-C | | For C-axis (Note) |
| CN3-11 | [Pr. PD09] | [Pr. PD09] | [Pr. PD09] | CALM | | Common pin |
| CN3-24 | [Pr. PD08] | [Pr. PD08] | [Pr. PD08] | CINP | | Common pin |

Note. The pin is not used for MR-J4 2-axis servo amplifiers.

(2) Output device explanations

| POINT | | |
|-----------------------------------------------------------------------------------------------------------------------|-------------|----------------------------------------------------------------------------------------|
| <p>● Initial letter and last letter with hyphen in device symbols mean target axis. Refer to the following table.</p> | | |
| Symbol (Note) | Target axis | Description |
| C ___ | A/B/C | When all axes of A, B, and C meet a condition, the device will be enabled (on or off). |
| X ___ | A/B/C | When each axis of A, B, or C meet a condition, the device will be enabled (on or off). |
| ___ -A | A-axis | Device for A-axis |
| ___ -B | B-axis | Device for B-axis |
| ___ -C | C-axis | Device for C-axis |
| <p>Note. ___ differs depending on devices.</p> | | |

| Device | Symbol | Function and application |
|--------------------------------------------|--------|----------------------------------------------------------------------------------------------------------------------------------------------------------------------------------------------------------------------------------------------------------------------------------------------------------------------------------------------------------|
| AND electromagnetic brake interlock | CMBR | When using the device, set operation delay time of the electromagnetic brake in [Pr. PC02]. When a servo-off status or alarm occurs, MBR will turn off. |
| OR electromagnetic brake interlock | XMBR | |
| Electromagnetic brake interlock for A-axis | MBR-A | |
| Electromagnetic brake interlock for B-axis | MBR-B | |
| Electromagnetic brake interlock for C-axis | MBR-C | |
| AND malfunction | CALM | When the protective circuit is activated to shut off the base circuit, ALM will turn off. When an alarm does not occur, ALM will turn on about 3 s after power-on. |
| OR malfunction | XALM | |
| Malfunction for A-axis | ALM-A | |
| Malfunction for B-axis | ALM-B | |
| Malfunction for C-axis | ALM-C | |
| AND in-position | CINP | When the number of droop pulses is in the preset in-position range, INP will turn on. The in-position range can be changed using [Pr. PA10]. When the in-position range is increased, INP may be on during low-speed rotation. The device cannot be used in the speed control mode, torque control mode, or continuous operation to torque control mode. |
| OR in-position | XINP | |
| In-position for A-axis | INP-A | |
| In-position for B-axis | INP-B | |
| In-position for C-axis | INP-C | |

3. SIGNALS AND WIRING

| Device | Symbol | Function and application |
|---------------------------------|--------|---------------------------------------------------------------------------------------------------------------------------------------------------------------------------------------------------------------------------------------------------------------------------------------------------------------------------------|
| AND ready | CRD | Enabling servo-on to make the servo amplifier ready to operate will turn on RD. |
| OR ready | XRD | |
| Common ready for A-axis | RD-A | |
| Common ready for B-axis | RD-B | |
| Common ready for C-axis | RD-C | |
| AND speed reached | CSA | SA will turn off during servo-off. When the servo motor speed reaches the following range, SA will turn on. Set speed $\pm ((\text{Set speed} \times 0.05) + 20)$ r/min When the preset speed is 20 r/min or less, SA always turns on. The device cannot be used in the position control mode and torque control mode. |
| OR speed reached | XSA | |
| Speed reached for A-axis | SA-A | |
| Speed reached for B-axis | SA-B | |
| Speed reached for C-axis | SA-C | |
| AND limiting speed | CVLC | |
| OR limiting speed | XVLC | |
| Limiting speed for A-axis | VLC-A | |
| Limiting speed for B-axis | VLC-B | |
| Limiting speed for C-axis | VLC-C | |
| AND zero speed detection | CZSP | ZSP turns on when the servo motor speed is zero speed (50 r/min) or less. Zero speed can be changed with [Pr. PC07]. |
| OR zero speed detection | XZSP | |
| Zero speed detection for A-axis | ZSP-A | |
| Zero speed detection for B-axis | ZSP-B | |
| Zero speed detection for C-axis | ZSP-C | |
| | | |
| AND limiting torque | CTL | When the torque reaches the torque limit value during torque generation, TLC will turn on. When the servo is off, TLC will be turned off. This device cannot be used in the torque control mode. |
| OR limiting torque | XTLC | |
| Limiting torque for A-axis | TLC-A | |
| Limiting torque for B-axis | TLC-B | |
| Limiting torque for C-axis | TLC-C | |

3. SIGNALS AND WIRING

| Device | Symbol | Function and application |
|-------------------------------------------|--------|---------------------------------------------------------------------------------------------------------------------------------------------------------------------------------------------------|
| AND warning | CWNG | When warning has occurred, WNG turns on. When a warning is not occurring, WNG will turn off about 3 s after power-on. |
| OR warning | XWNG | |
| Warning for A-axis | WNG-A | |
| Warning for B-axis | WNG-B | |
| Warning for C-axis | WNG-C | |
| AND battery warning | CBWNG | BWNG turns on when [AL. 92 Battery cable disconnection warning] or [AL. 9F Battery warning] has occurred. When the battery warning is not occurring, BWNG will turn off about 3 s after power-on. |
| OR battery warning | XBWNG | |
| Battery warning for A-axis | BWNG-A | |
| Battery warning for B-axis | BWNG-B | |
| Battery warning for C-axis | BWNG-C | |
| AND variable gain selection | CCDPS | CDPS will turn on during variable gain. |
| OR variable gain selection | XCDPS | |
| Variable gain selection for A-axis | CDPS-A | |
| Variable gain selection for B-axis | CDPS-B | |
| Variable gain selection for C-axis | CDPS-C | |
| AND absolute position undetermined | CABSV | ABSV turns on when the absolute position is undetermined. The device cannot be used in the speed control mode and torque control mode. |
| OR absolute position undetermined | XABSV | |
| Absolute position undetermined for A-axis | ABSV-A | |
| Absolute position undetermined for B-axis | ABSV-B | |
| Absolute position undetermined for C-axis | ABSV-C | |
| AND during tough drive | CMTTR | When a tough drive is enabled in [Pr. PA20], activating the instantaneous power failure tough drive will turn on MTTR. |
| OR during tough drive | XMTR | |
| Tough drive for A-axis | MTTR-A | |
| Tough drive for B-axis | MTTR-B | |
| Tough drive for C-axis | MTTR-C | |
| AND during fully closed loop control | CCLDS | CLDS turns on during fully closed loop control. |
| OR during fully closed loop control | XCLDS | |
| During fully closed loop control A-axis | CLDS-A | |
| During fully closed loop control B-axis | CLDS-B | |
| During fully closed loop control C-axis | CLDS-C | |

3. SIGNALS AND WIRING

3.5.3 Output signal

| Signal name | Symbol | Connector Pin No. | Function and application |
|-------------------------------------------------------|---------------|-------------------|---------------------------------------------------------------------------------------------------------------------------------------------------------------------------------------------------------------------------------------|
| Encoder A-phase pulse A (differential line driver) | LA-A LAR-A | CN3-3 CN3-16 | The encoder output pulses set in [Pr. PA15] and [Pr. PA16] are output in differential line driver type. In CCW rotation of the servo motor, the encoder B-phase pulse lags the encoder A-phase pulse by a phase angle of $\pi/2$. |
| Encoder B-phase pulse A (differential line driver) | LB-A LBR-A | CN3-4 CN3-17 | The relation between rotation direction and phase difference of the A-phase and B-phase pulses can be changed with [Pr. PC03]. Output pulse specification, dividing ratio setting, and electronic gear setting can be selected. |
| Encoder A-phase pulse B (differential line driver) | LA-B LAR-B | CN3-5 CN3-18 | These signals cannot be used for MR-J4W3-_B. |
| Encoder B-phase pulse B (differential line driver) | LB-B LBR-B | CN3-6 CN3-19 | |

3.5.4 Power supply

| Signal name | Symbol | Connector Pin No. | Function and application |
|-------------------------|--------|-------------------|-----------------------------------------------------------------------------------------------------------------------------------------------------------------------------------------------------------------------------------------------------------------------------------------------------------------------------------|
| Digital I/F power input | DICOM | CN3-23 | Input 24 V DC (24 V DC \pm 10% MR-J4W2-_B: 350 mA, MR-J4W3-_B: 450 mA) for I/O interface. The power supply capacity changes depending on the number of I/O interface points to be used. For sink interface, connect + of 24 V DC external power supply. For source interface, connect - of 24 V DC external power supply. |
| Digital I/F common | DOCOM | CN3-26 | Common terminal for input device such as EM2 of the servo amplifier. This is separated from LG. For sink interface, connect - of 24 V DC external power supply. For source interface, connect + of 24 V DC external power supply. |
| Control common | LG | CN3-14 | This is for encoder output pulses (differential line driver). |
| Shield | SD | Plate | Connect the external conductor of the shielded wire. |

3. SIGNALS AND WIRING

3.6 Forced stop deceleration function

| POINT |
|-------------------------------------------------------------------------------------------------------------------------------------------------------------------------------------------------------------------------------------------------------------------|
| ●When alarms not related to the forced stop function occur, control of motor deceleration cannot be guaranteed. (Refer to section 8.1.) |
| ●When SSCNET III/H communication shut-off occurs, forced stop deceleration will operate. (Refer to section 3.7 (3).) |
| ●In the torque control mode, the forced stop deceleration function is not available. |
| ●Disable the forced stop deceleration function for a machine in which multiple axes are connected together, such as a tandem structure. If an alarm occurs with the forced stop deceleration function disabled, the servo motor will stop with the dynamic brake. |

3.6.1 Forced stop deceleration function

When EM2 is turned off, dynamic brake will start to stop the servo motor after forced stop deceleration.

During this sequence, the display shows [AL. E6 Servo forced stop warning].

During normal operation, do not use EM2 (Forced stop 2) to alternate stop and run. The servo amplifier life may be shortened.

(1) Connection diagram

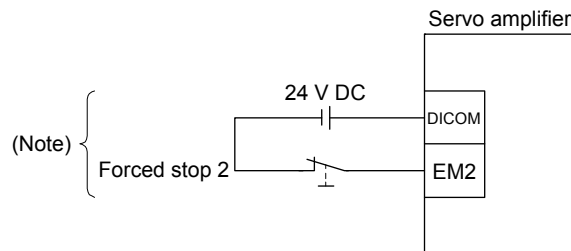

Note. This diagram shows sink I/O interface. For source I/O interface, refer to section 3.8.3.

3. SIGNALS AND WIRING

(2) Timing chart

When EM2 (Forced stop 2) turns off, the motor will decelerate according to [Pr. PC24 Forced stop deceleration time constant]. Once the motor speed is below [Pr. PC07 Zero speed], base power is cut and the dynamic brake activates. For MR-J4W_-B servo amplifiers, forced stop deceleration operates for all axes.

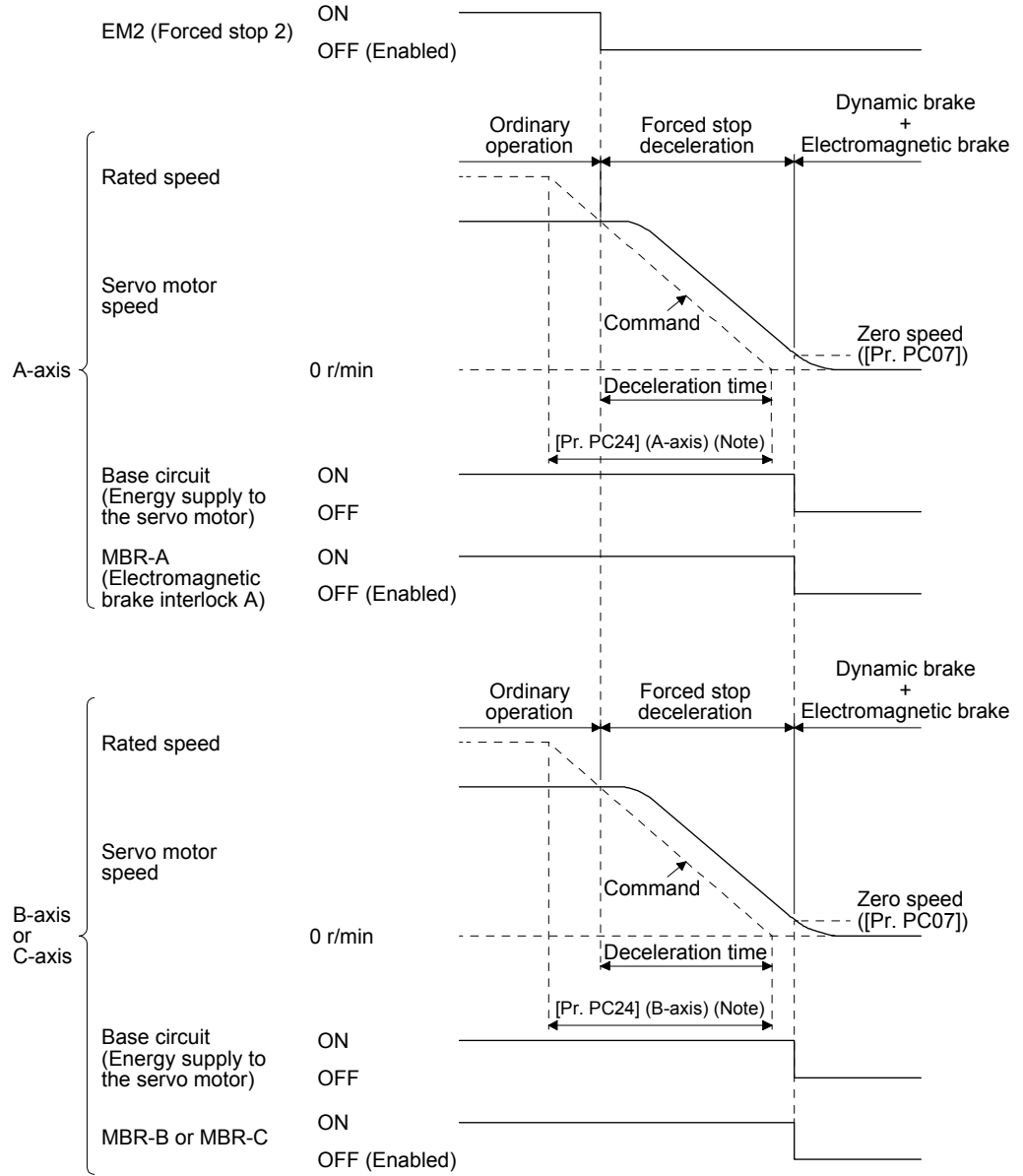

Note. To decelerate all axes of A, B, and C, set the same value to [Pr. PC24] for all axes.

3. SIGNALS AND WIRING

3.6.2 Base circuit shut-off delay time function

The base circuit shut-off delay time function is used to prevent vertical axis from dropping at a forced stop (EM2 goes off), alarm occurrence, or SSCNET III/H communication shut-off due to delay time of the electromagnetic brake. Set the time from MBR (Electromagnetic brake interlock) off to base circuit shut-off with [Pr. PC02].

(1) Timing chart

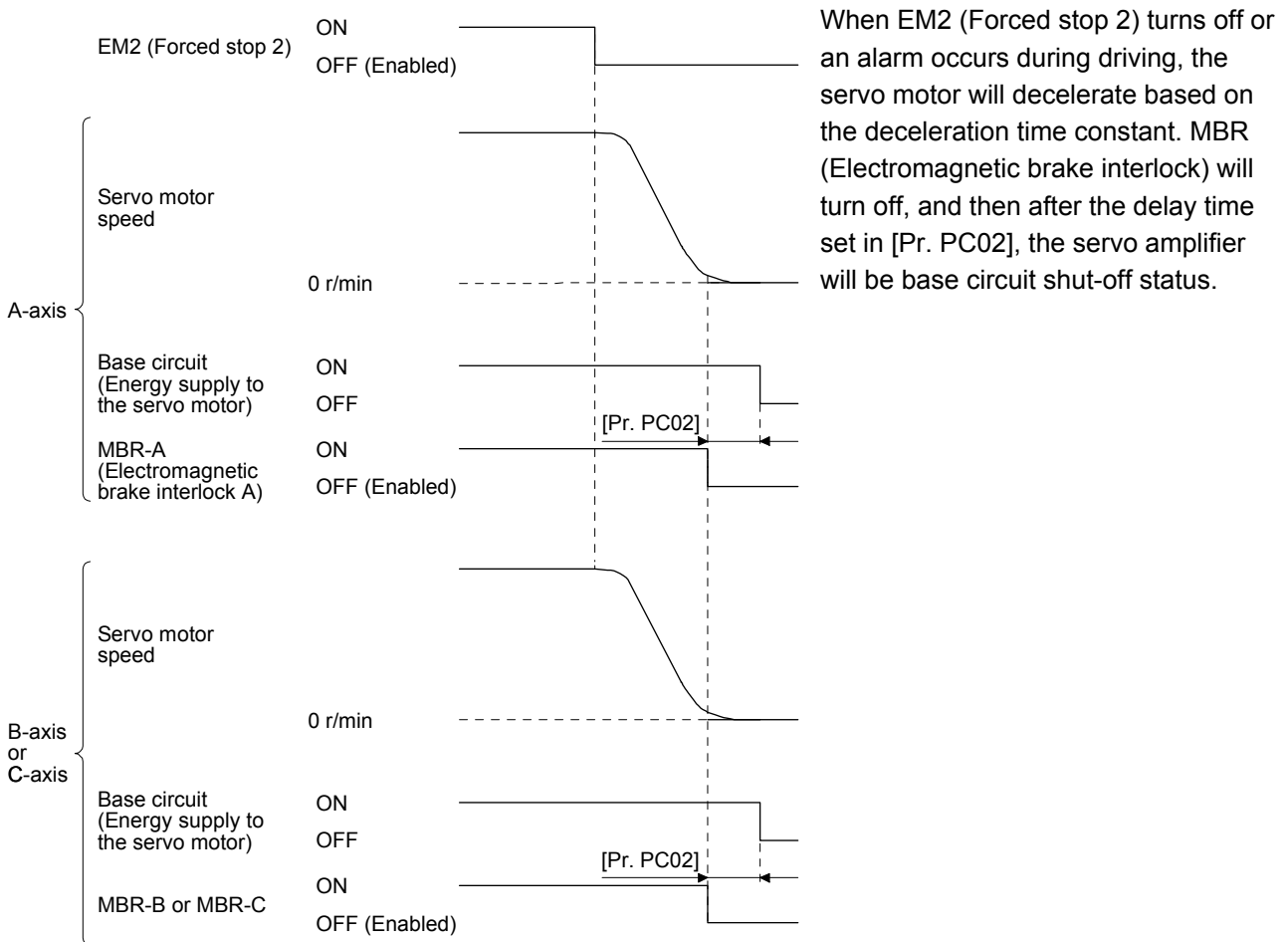

(2) Adjustment

While the servo motor is stopped, turn off EM2 (Forced stop 2), adjust the base circuit shut-off delay time in [Pr. PC02], and set the value to approximately 1.5 times of the smallest delay time in which the servo motor shaft does not freefall.

3. SIGNALS AND WIRING

3.6.3 Vertical axis freefall prevention function

The vertical axis freefall prevention function avoids machine damage by pulling up the shaft slightly like the following case.

When the servo motor is used for operating vertical axis, the servo motor electromagnetic brake and the base circuit shut-off delay time function avoid dropping axis at forced stop. However, the functions may not avoid dropping axis a few μm due to the backlash of the servo motor electromagnetic brake.

The vertical axis freefall prevention function is enabled with the following conditions.

- Other than "0" is set to [Pr. PC31 Vertical axis freefall prevention compensation amount].
- EM2 (Forced stop 2) turned off, an alarm occurred, or SSCNETIII/H communication shut-off occurred while the servo motor speed is zero speed or less.
- The base circuit shut-off delay time function is enabled.

(1) Timing chart

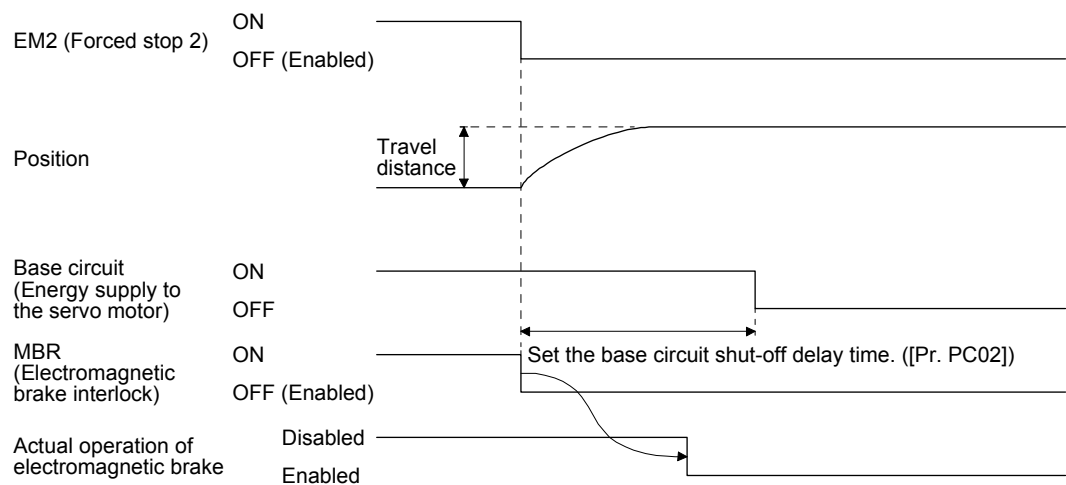

(2) Adjustment

- Set the freefall prevention compensation amount in [Pr. PC31].
- While the servo motor is stopped, turn off the EM2 (Forced stop 2). Adjust the base circuit shut-off delay time in [Pr. PC02] in accordance with the travel distance ([Pr. PC31]). Adjust it considering the freefall prevention compensation amount by checking the servo motor speed, torque ripple, etc.

3.6.4 Residual risks of the forced stop function (EM2)

- (1) The forced stop function is not available for alarms that activate the dynamic brake when the alarms occur.
- (2) When an alarm that activates the dynamic brake during forced stop deceleration occurs, the braking distance until the servo motor stops will be longer than that of normal forced stop deceleration without the dynamic brake.
- (3) If STO is turned off during forced stop deceleration, [AL. 63 STO timing error] will occur.

3. SIGNALS AND WIRING

3.7 Alarm occurrence timing chart

| | |
|--------------------------------------------------------------------------------------------------|------------------------------------------------------------------------------------------------------------------------------------------------------------------------------------------------------------------------------------------------------------------------------------------------------------------------------------------------------------------------------------------------------------------------------------------------------------------|
|  CAUTION | <ul style="list-style-type: none"> ● When an alarm has occurred, remove its cause, make sure that the operation signal is not being input, ensure safety, and reset the alarm before restarting operation. ● When alarms are occurring in all axes of A, B, and C, shut off the main circuit power supply. Not doing so may cause a fire when a regenerative transistor malfunctions or the like may overheat the regenerative resistor. |
|--------------------------------------------------------------------------------------------------|------------------------------------------------------------------------------------------------------------------------------------------------------------------------------------------------------------------------------------------------------------------------------------------------------------------------------------------------------------------------------------------------------------------------------------------------------------------|

| |
|-----------------------------------------------------------------------------------------------------------------------------------------|
| POINT |
| <ul style="list-style-type: none"> ● In the torque control mode, the forced stop deceleration function is not available. |

To deactivate the alarm, cycle the control circuit power or give the error reset or CPU reset command from the servo system controller. However, the alarm cannot be deactivated unless its cause is removed.

3.7.1 When you use the forced stop deceleration function

| |
|----------------------------------------------------------------------------------------------------------------------------------------------------------------------------------------------------------------------------------------------------------------------------------------------------------------------------------------------------------------------------------------------------|
| POINT |
| <ul style="list-style-type: none"> ● To enable the function, set "2 ___ (initial value)" in [Pr. PA04]. ● Disable the forced stop deceleration function for a machine in which multiple axes are connected together, such as a tandem structure. If an alarm occurs with the forced stop deceleration function disabled, the servo motor will stop with the dynamic brake. |

(1) When the forced stop deceleration function is enabled

When an all-axis stop alarm occur, all axes will be the operation status below. When a corresponding axis stop alarm occurs, only the axis will be the operation status below. You can normally operate the axis that any alarm is not occurring.

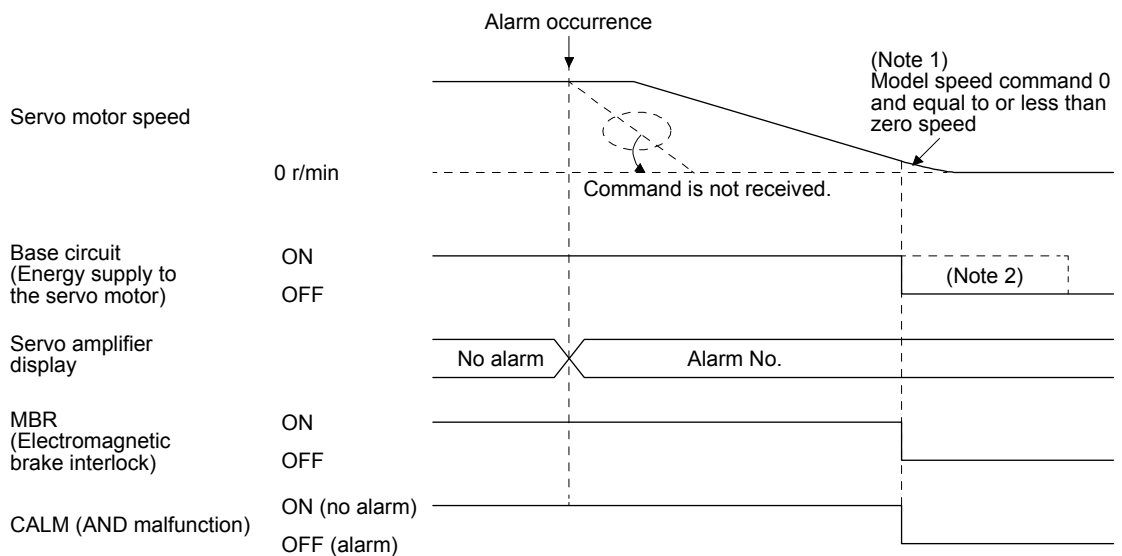

- Note 1. The model speed command is a speed command generated in the servo amplifier for forced stop deceleration of the servo motor.
- Note 2. This is for when the electronic dynamic brake is enabled with [Pr. PF06] while a certain servo motor is used. If the servo motor speed is 5 r/min or higher, the electronic dynamic brake will operate continuously for the time period set in [Pr. PF12].

3. SIGNALS AND WIRING

(2) When the forced stop deceleration function is not enabled

When an all-axis stop alarm occur, all axes will be the operation status below. When a corresponding axis stop alarm occurs, only the axis will be the operation status below. You can normally operate the axis that any alarm is not occurring.

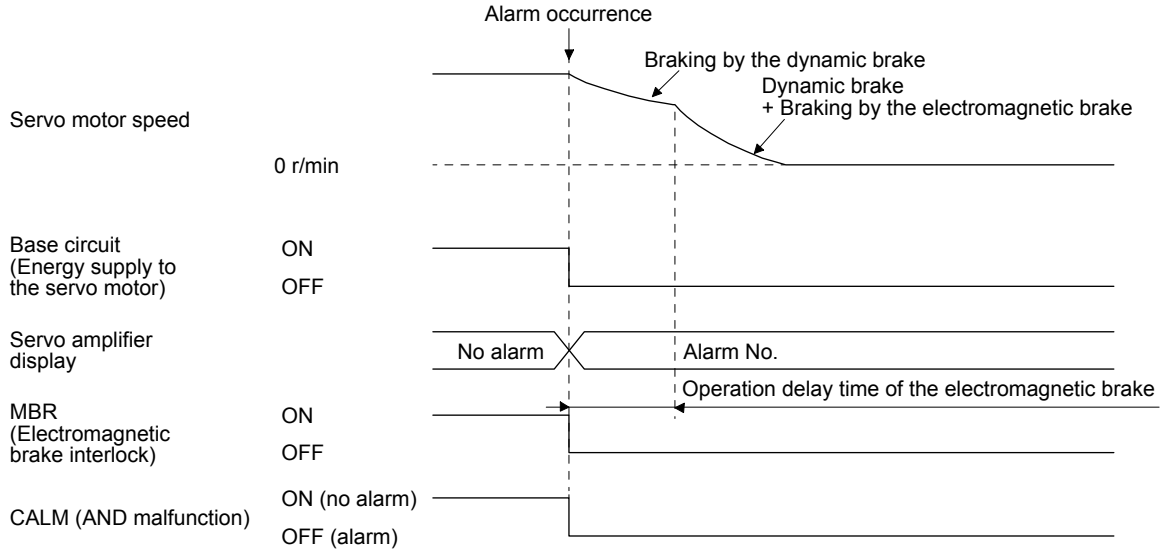

(3) When SSCNET III/H communication shut-off occurs

When SSCNET III/H communication is broken, all axes will be the operation status below. The dynamic brake may operate depending on the communication shut-off status.

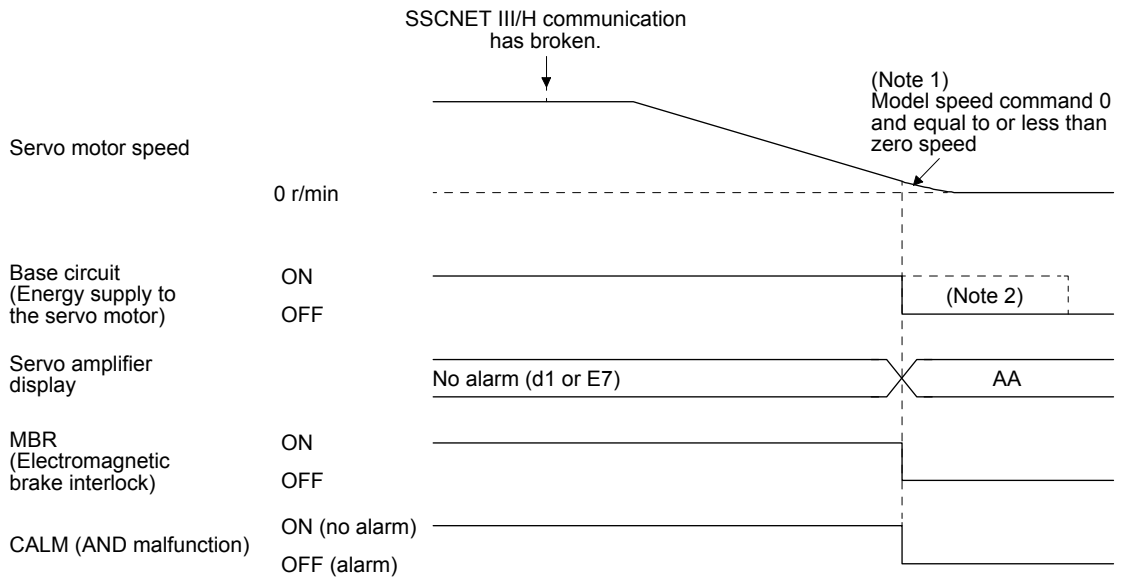

- Note 1. The model speed command is a speed command generated in the servo amplifier for forced stop deceleration of the servo motor.
- Note 2. This is for when the electronic dynamic brake is enabled with [Pr. PF06] while a certain servo motor is used. If the servo motor speed is 5 r/min or higher, the electronic dynamic brake will operate continuously for the time period set in [Pr. PF12].

3. SIGNALS AND WIRING

3.7.2 When you do not use the forced stop deceleration function

| POINT |
|--------------------------------------------------------|
| ●To disable the function, set "0 _ _ _" in [Pr. PA04]. |

The timing chart that shows the servo motor condition when an alarm or SSCNETIII/H communication shut-off occurs is the same as section 3.7.1 (2).

3. SIGNALS AND WIRING

3.8 Interfaces

3.8.1 Internal connection diagram

POINT

● Refer to section 13.3.1 for the CN8 connector.

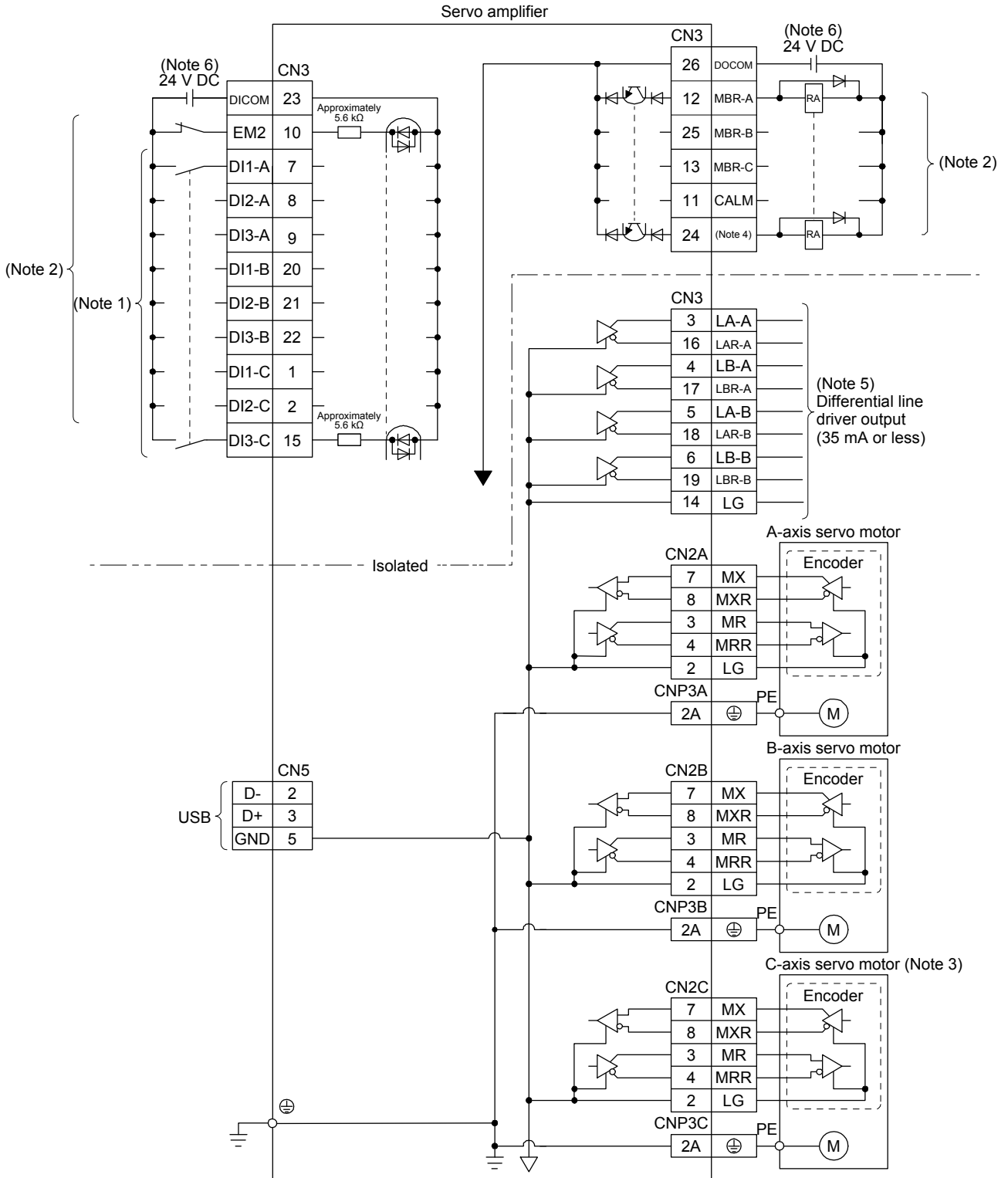

3. SIGNALS AND WIRING

Note 1. Signal can be assigned for these pins with the controller setting.

For contents of signals, refer to the instruction manual of the controller.

2. This diagram shows sink I/O interface. For source I/O interface, refer to section 3.8.3.

3. For the MR-J4 3-axis servo amplifier

4. In the initial setting, CINP (AND in-position) is assigned to the pin. You can change devices of the pin with [Pr. PD08].

5. This signal cannot be used for MR-J4W3-_B.

6. The illustration of the 24 V DC power supply is divided between input signal and output signal for convenience. However, they can be configured by one.

3.8.2 Detailed description of interfaces

This section provides the details of the I/O signal interfaces (refer to the I/O division in the table) given in section 3.5. Refer to this section and make connection with the external device.

(1) Digital input interface DI-1

This is an input circuit whose photocoupler cathode side is the input terminal. Transmit signals from sink (open-collector) type transistor output, relay switch, etc. The following is a connection diagram for sink input. Refer to section 3.8.3 for source input.

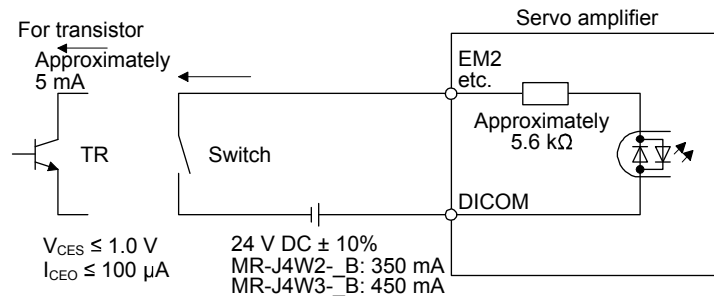

(2) Digital output interface DO-1

This is a circuit in which the collector of the output transistor is the output terminal. When the output transistor is turned on, the current will flow to the collector terminal.

A lamp, relay or photocoupler can be driven. Install a diode (D) for an inductive load, or install an inrush current suppressing resistor (R) for a lamp load.

(Rated current: 40 mA or less, maximum current: 50 mA or less, inrush current: 100 mA or less) A maximum of 2.6 V voltage drop occurs in the servo amplifier.

The following shows a connection diagram for sink output. Refer to section 3.8.3 for source output.

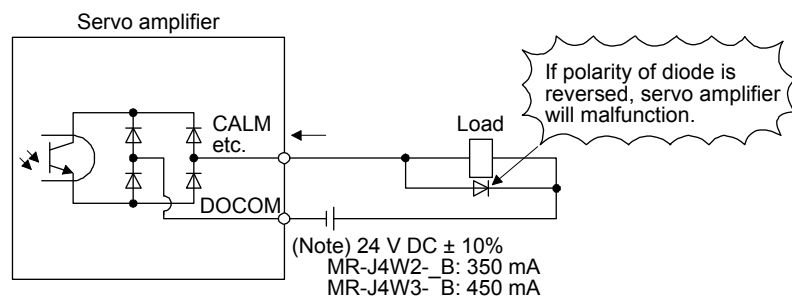

Note. If the voltage drop (maximum of 2.6 V) interferes with the relay operation, apply high voltage (maximum of 26.4 V) from external source.

3. SIGNALS AND WIRING

(3) Encoder output pulses DO-2 (differential line driver type)

(a) Interface

Maximum output current: 35 mA

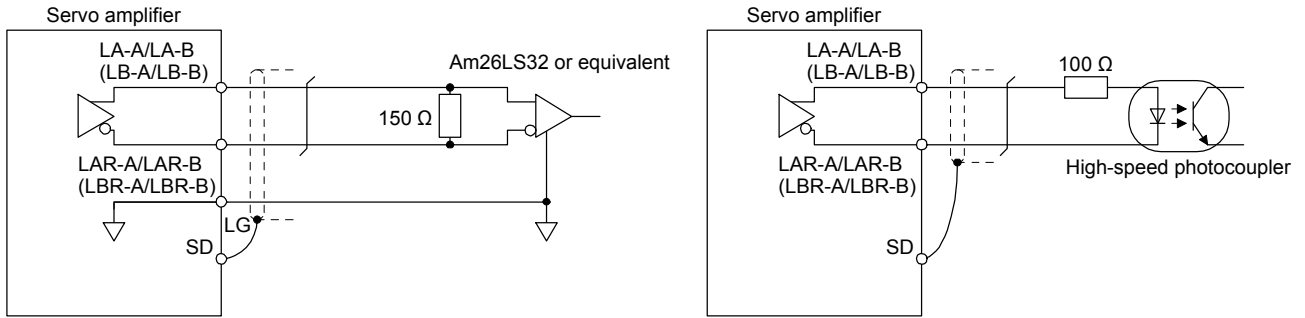

(b) Output pulse

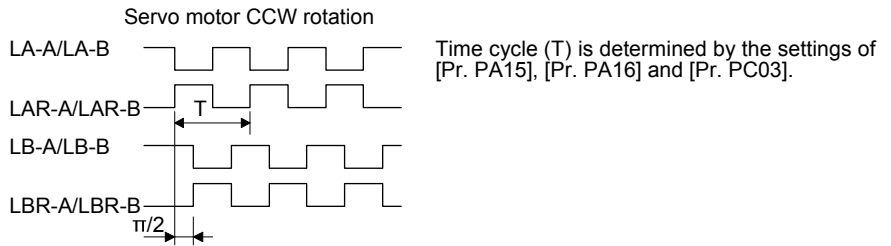

3.8.3 Source I/O interfaces

In this servo amplifier, source type I/O interfaces can be used.

(1) Digital input interface DI-1

This is an input circuit whose photocoupler anode side is the input terminal. Transmit signals from source (open-collector) type transistor output, relay switch, etc.

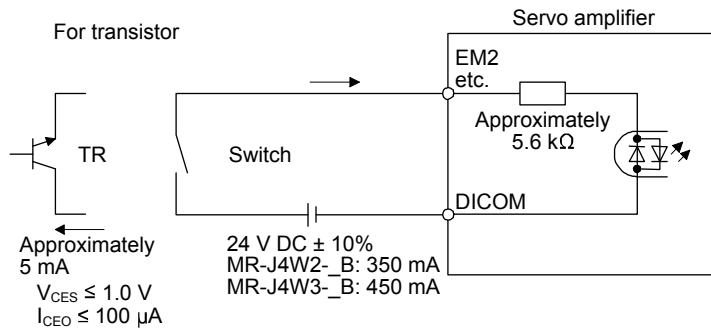

3. SIGNALS AND WIRING

(2) Digital output interface DO-1

This is a circuit in which the emitter of the output transistor is the output terminal. When the output transistor is turned on, the current will flow from the output terminal to a load.

A maximum of 2.6 V voltage drop occurs in the servo amplifier.

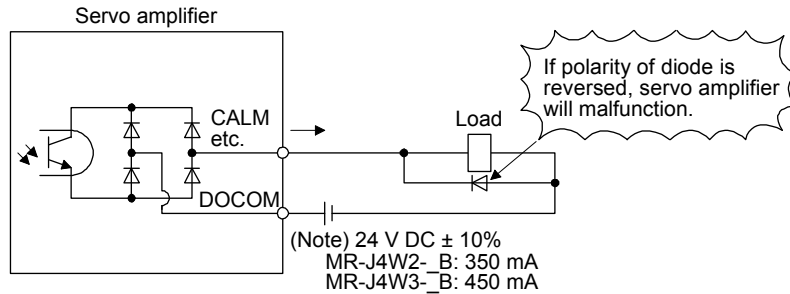

Note. If the voltage drop (maximum of 2.6 V) interferes with the relay operation, apply high voltage (maximum of 26.4 V) from external source.

3.9 SSCNET III cable connection

| POINT |
|-------------------------------------------------------------------------------------------------------------------------------------------------------------------------------------------------------------------------------------|
| <ul style="list-style-type: none"> Do not look directly at the light generated from CN1A/CN1B connector of the servo amplifier or the end of SSCNET III cable. The light can be a discomfort when it enters the eye. |

(1) SSCNET III cable connection

For the CN1A connector, connect the SSCNET III cable connected to a controller in host side or a servo amplifier of the previous axis. For CN1B connector, connect SSCNET III cable connected to servo amplifier of the next axis. For CN1B connector of the final axis, put a cap came with servo amplifier.

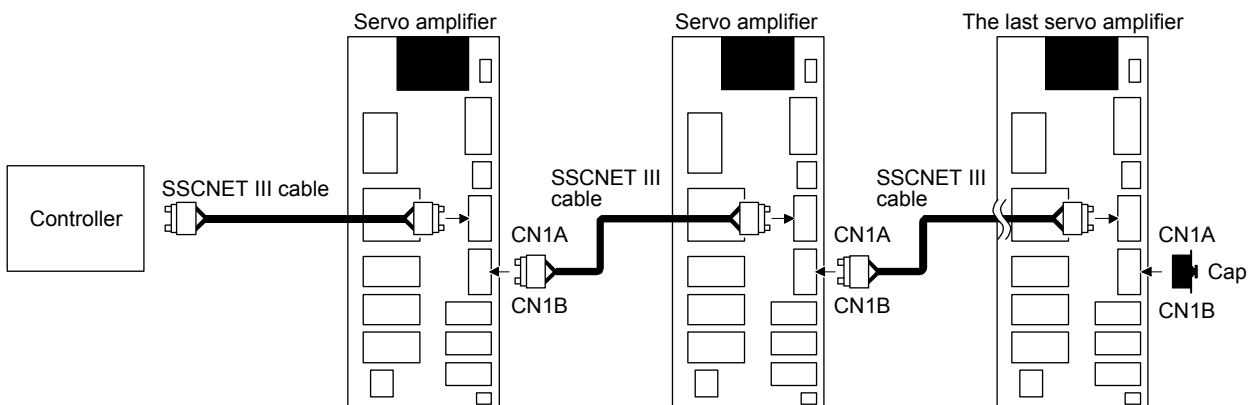

3. SIGNALS AND WIRING

(2) How to connect/disconnect cable

| POINT |
|------------------------------------------------------------------------------------------------------------------------------------------------------------------------------------------------------------------------------------------------------------------|
| ●CN1A and CN1B connector are capped to protect light device inside connector from dust. For this reason, do not remove the cap until just before connecting the SSCNET III cable. Then, when removing SSCNET III cable, make sure to put a cap. |
| ●Keep the cap for CN1A/CN1B connector and the tube for protecting optical cord end of SSCNET III cable in a plastic bag with a slide fastener of SSCNET III cable to prevent them from becoming dirty. |
| ●When asking repair of servo amplifier for some malfunctions, make sure to cap CN1A and CN1B connector. When the connector is not put a cap, the light device may be damaged at the transit. In this case, replacing and repairing the light device is required. |

(a) Connection

- 1) For SSCNET III cable in the shipping status, the tube for protect optical cord end is put on the end of connector. Remove this tube.
- 2) Remove the CN1A and CN1B connector caps of the servo amplifier.
- 3) With holding a tab of SSCNET III cable connector, make sure to insert it into the CN1A and CN1B connector of the servo amplifier until you hear the click. If the end face of optical cord tip is dirty, optical transmission is interrupted and it may cause malfunctions. If it becomes dirty, wipe with a bonded textile, etc. Do not use solvent such as alcohol.

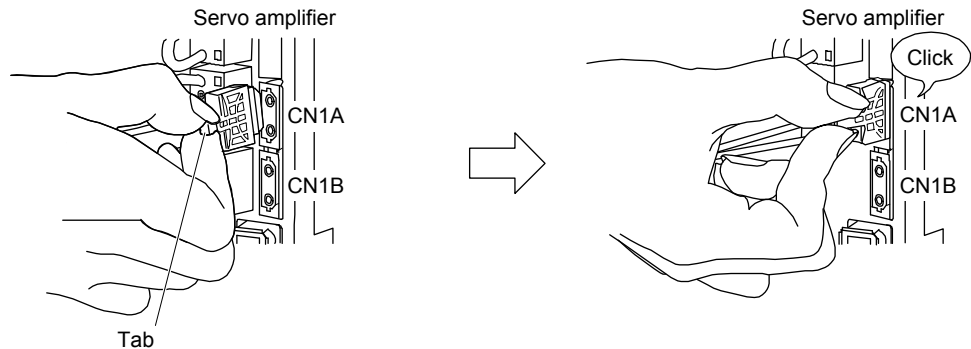

(b) Disconnection

With holding a tab of SSCNET III cable connector, pull out the connector. When pulling out the SSCNET III cable from servo amplifier, be sure to put the cap on the connector parts of servo amplifier to prevent it from becoming dirty. For SSCNET III cable, attach the tube for protection optical cord's end face on the end of connector.

3. SIGNALS AND WIRING

3.10 Servo motor with an electromagnetic brake

3.10.1 Safety precautions

- Configure an electromagnetic brake circuit which is interlocked with an external emergency stop switch.

Contacts must be opened when CALM (AND malfunction) or MBR (Electromagnetic brake interlock) turns off.

Contacts must be opened with the emergency stop switch.

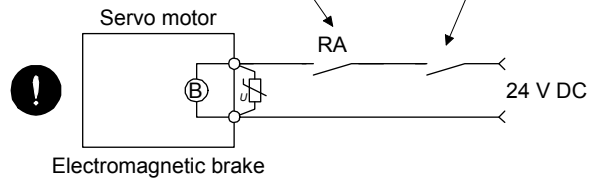

CAUTION

- The electromagnetic brake is provided for holding purpose and must not be used for ordinary braking.
- Before operating the servo motor, be sure to confirm that the electromagnetic brake operates properly.
- Do not use the 24 V DC interface power supply for the electromagnetic brake. Always use the power supply designed exclusively for the electromagnetic brake. Otherwise, it may cause a malfunction.
- When using EM2 (Forced stop 2), use MBR (Electromagnetic brake interlock) for operating the electromagnetic brake. Operating the electromagnetic brake without using MBR during deceleration to a stop will saturate servo motor torques at the maximum value due to brake torques of the electromagnetic brake and can result in delay of the deceleration to a stop from a set value.

POINT

- Refer to "Servo Motor Instruction Manual (Vol. 3)" for specifications such as the power supply capacity and operation delay time of the electromagnetic brake.
- Refer to "Servo Motor Instruction Manual (Vol. 3)" or section 11.19 for the selection of a surge absorber for the electromagnetic brake.

Note the following when the servo motor with an electromagnetic brake is used.

- 1) The brake will operate when the power (24 V DC) turns off.
- 2) Turn off the servo-on command after the servo motor stopped.

3. SIGNALS AND WIRING

(1) Connection diagram

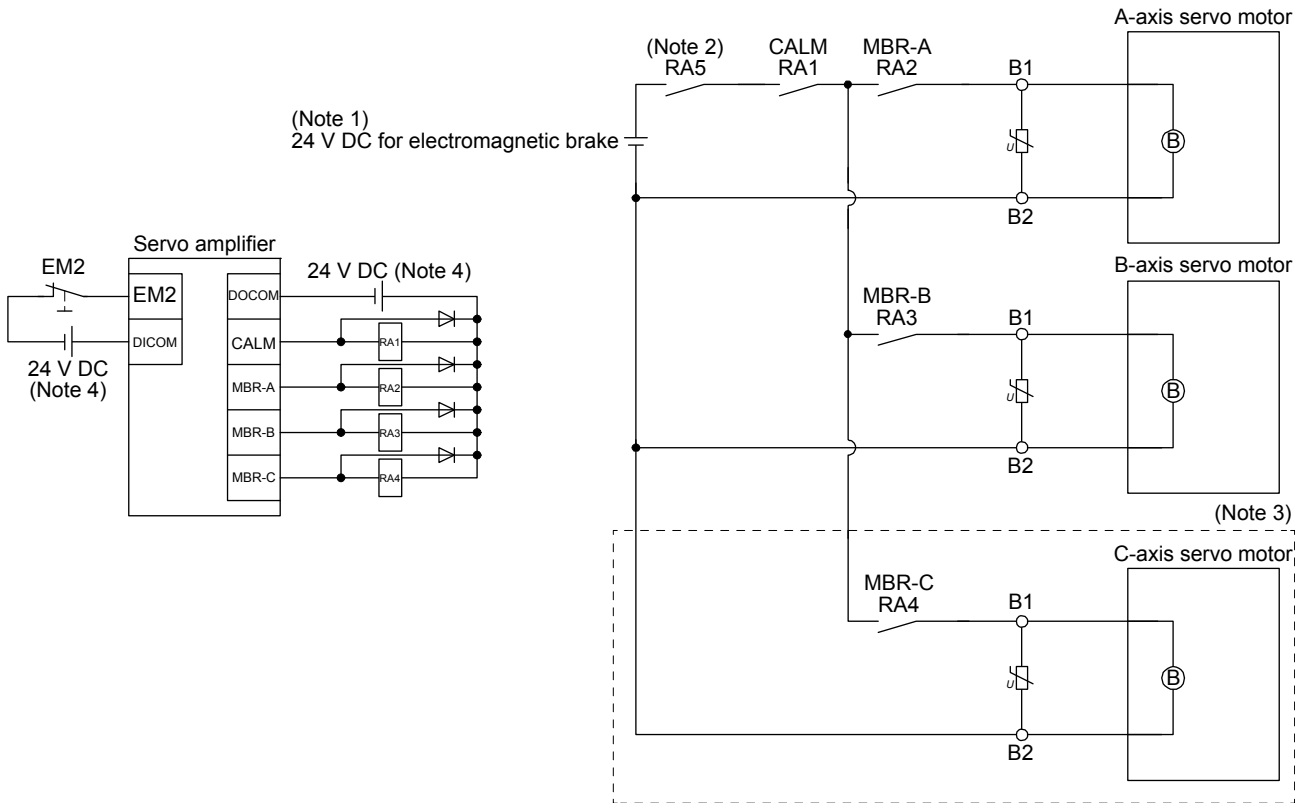

- Note 1. Do not use the 24 V DC interface power supply for the electromagnetic brake.
- Note 2. Create the circuit in order to shut off by interlocking with the emergency stop switch.
- Note 3. This connection is for the MR-J4 3-axis servo amplifier.
- Note 4. The illustration of the 24 V DC power supply is divided between input signal and output signal for convenience. However, they can be configured by one.

(2) Setting

In [Pr. PC02 Electromagnetic brake sequence output], set the time delay (Tb) from MBR (Electromagnetic brake interlock) off to base circuit shut-off at a servo-off as in the timing chart in section 3.10.2.

3. SIGNALS AND WIRING

3.10.2 Timing chart

(1) When you use the forced stop deceleration function

POINT

● To enable the function, set "2 _ _ _ (initial value)" in [Pr. PA04].

(a) Servo-on command (from controller) on/off

When servo-on command is turned off, the servo lock will be released after T_b [ms], and the servo motor will coast. If the electromagnetic brake is enabled during servo-lock, the brake life may be shorter. Therefore, set T_b about 1.5 times of the minimum delay time where the moving part will not drop down for a vertical axis system, etc.

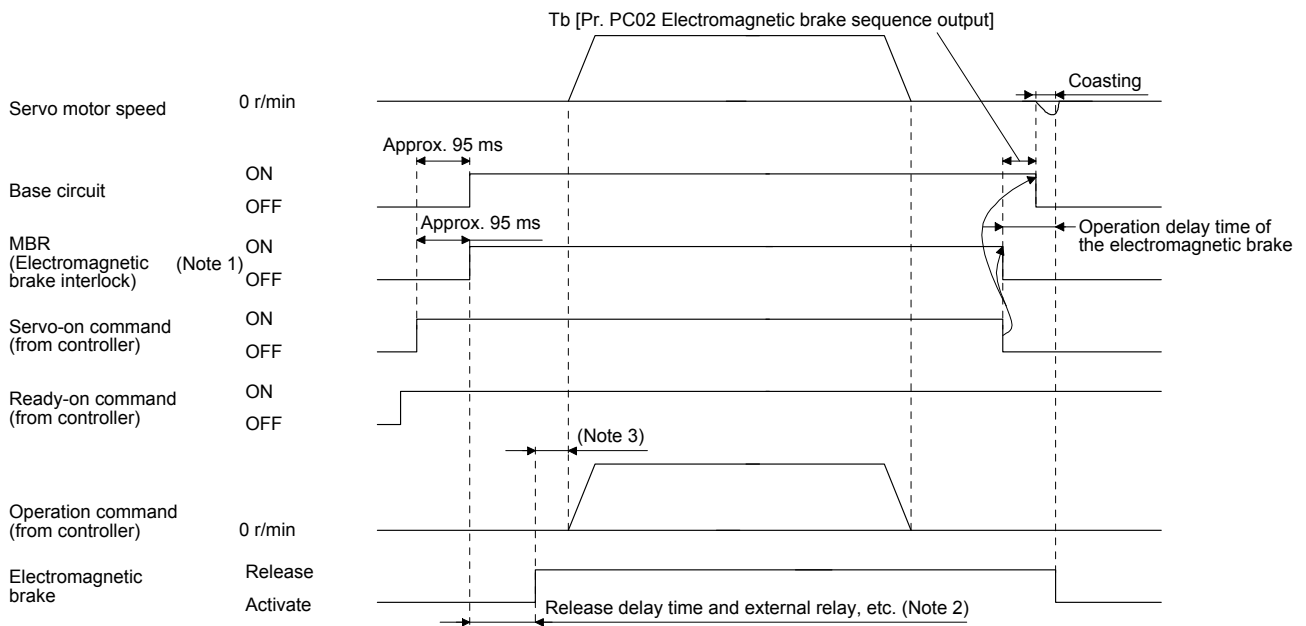

Note 1. ON : Electromagnetic brake is not activated.
OFF: Electromagnetic brake is activated.

2. Electromagnetic brake is released after delaying for the release delay time of electromagnetic brake and operation time of external circuit relay. For the release delay time of electromagnetic brake, refer to "Servo Motor Instruction Manual (Vol. 3)".
3. Give the operation command from the controller after the electromagnetic brake is released.

3. SIGNALS AND WIRING

- (b) Off/on of the forced stop command (from controller) or EM2 (Forced stop 2)
 When EM2 is turned off, all axes will be the operation status below.

POINT

● In the torque control mode, the forced stop deceleration function is not available.

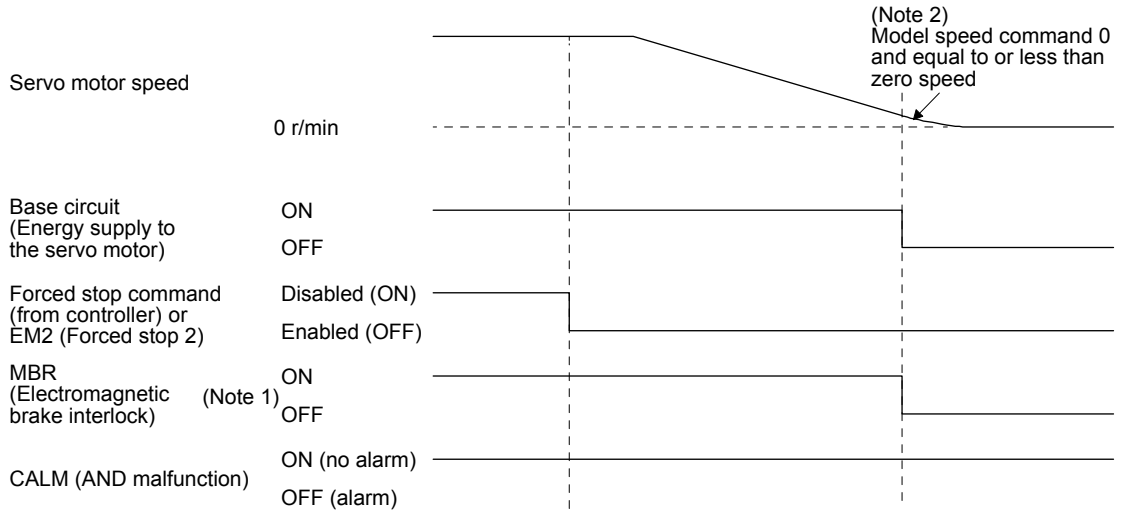

- Note 1. ON : Electromagnetic brake is not activated.
 OFF: Electromagnetic brake is activated.
- Note 2. The model speed command is a speed command generated in the servo amplifier for forced stop deceleration of the servo motor.

- (c) Alarm occurrence
 The operation status during an alarm is the same as section 3.7.

- (d) Both main and control circuit power supplies off
 When both main and control circuit power supplies are turned off, all axes will be the operation status below.

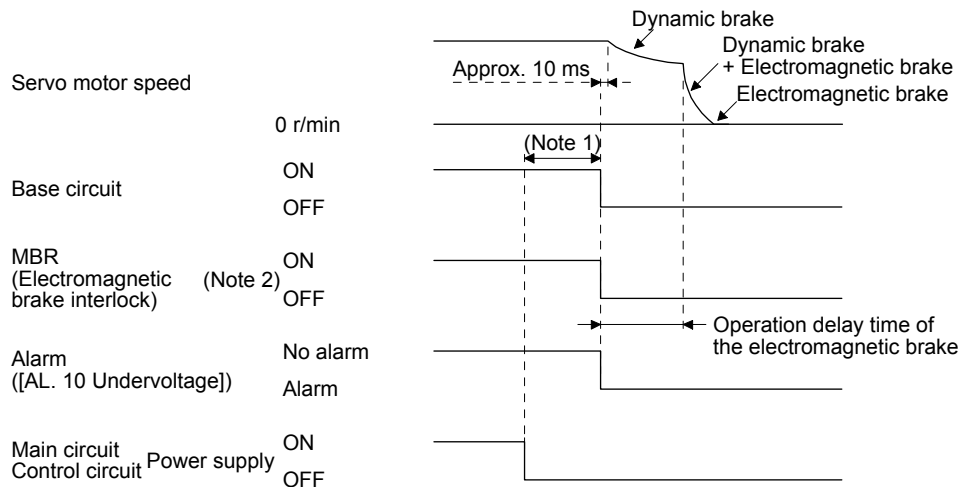

- Note 1. Variable according to the operation status.
- Note 2. ON : Electromagnetic brake is not activated.
 OFF: Electromagnetic brake is activated.

3. SIGNALS AND WIRING

(e) Main circuit power supply off during control circuit power supply on

When the main circuit power supply is turned off, all axes will be the operation status below.

POINT

● In the torque control mode, the forced stop deceleration function is not available.

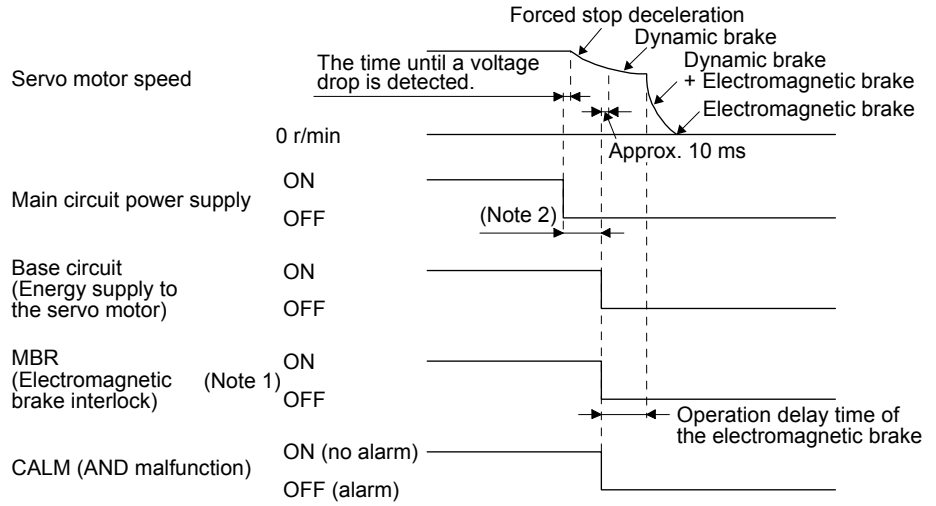

- Note 1. ON : Electromagnetic brake is not activated.
 OFF: Electromagnetic brake is activated.
- Note 2. Variable according to the operation status.

(f) Ready-off command from controller

When ready-off is received, all axes will be the operation status below.

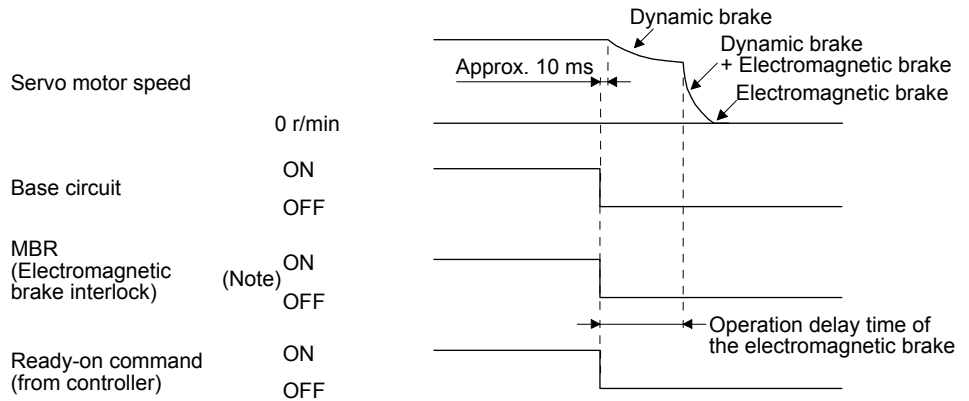

- Note. ON : Electromagnetic brake is not activated.
 OFF: Electromagnetic brake is activated.

3. SIGNALS AND WIRING

(2) When you do not use the forced stop deceleration function

| |
|---------------------------------------------------------|
| POINT |
| ● To disable the function, set "0 _ _ _" in [Pr. PA04]. |

(a) Servo-on command (from controller) on/off
It is the same as (1) (a) in this section.

(b) Off/on of the forced stop command (from controller) or EM1 (Forced stop)
When the controller forced stop warning is received from a controller or EM1 is turned off, all axes will be the operation status below.

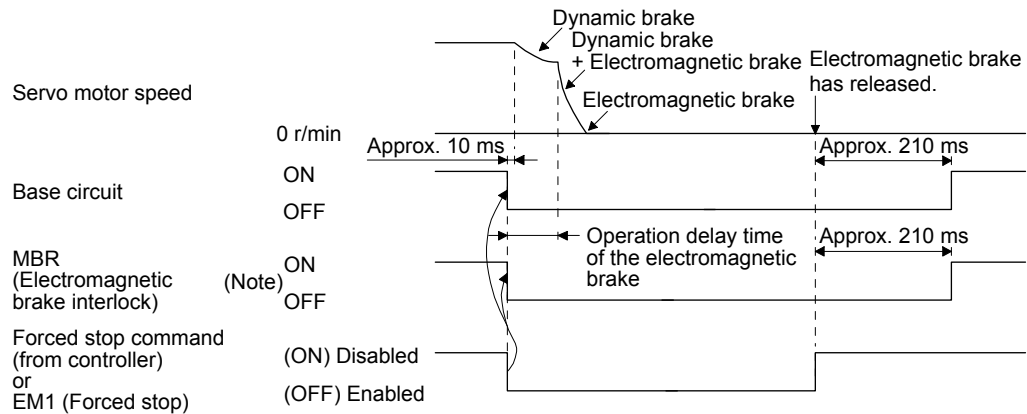

Note. ON : Electromagnetic brake is not activated.
OFF: Electromagnetic brake is activated.

(c) Alarm occurrence

The operation status during an alarm is the same as section 3.7.

(d) Both main and control circuit power supplies off

It is the same as (1) (d) in this section.

3. SIGNALS AND WIRING

(e) Main circuit power supply off during control circuit power supply on

When the main circuit power supply is turned off, all axes will be the operation status below.

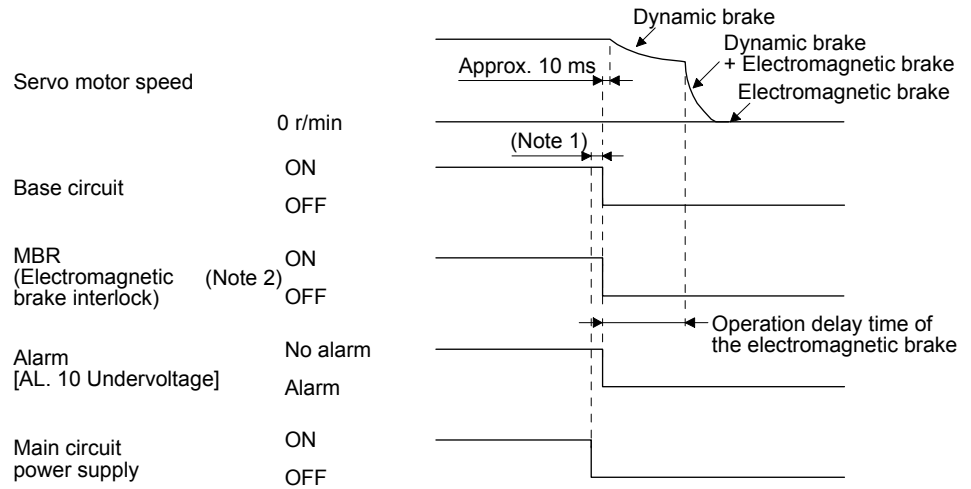

- Note 1. Variable according to the operation status.
 Note 2. ON : Electromagnetic brake is not activated.
 OFF: Electromagnetic brake is activated.

(f) Ready-off command from controller

It is the same as (1) (f) in this section.

3. SIGNALS AND WIRING

3.11 Grounding

WARNING ● Ground the servo amplifier and servo motor securely.
 ● To prevent an electric shock, always connect the protective earth (PE) terminal (marked ⊕) of the servo amplifier to the protective earth (PE) of the cabinet.

The servo amplifier switches the power transistor on-off to supply power to the servo motor. Depending on the wiring and ground cable routing, the servo amplifier may be affected by the switching noise (due to di/dt and dv/dt) of the transistor. To prevent such a fault, refer to the following diagram and always ground. To conform to the EMC Directive, refer to "EMC Installation Guidelines".

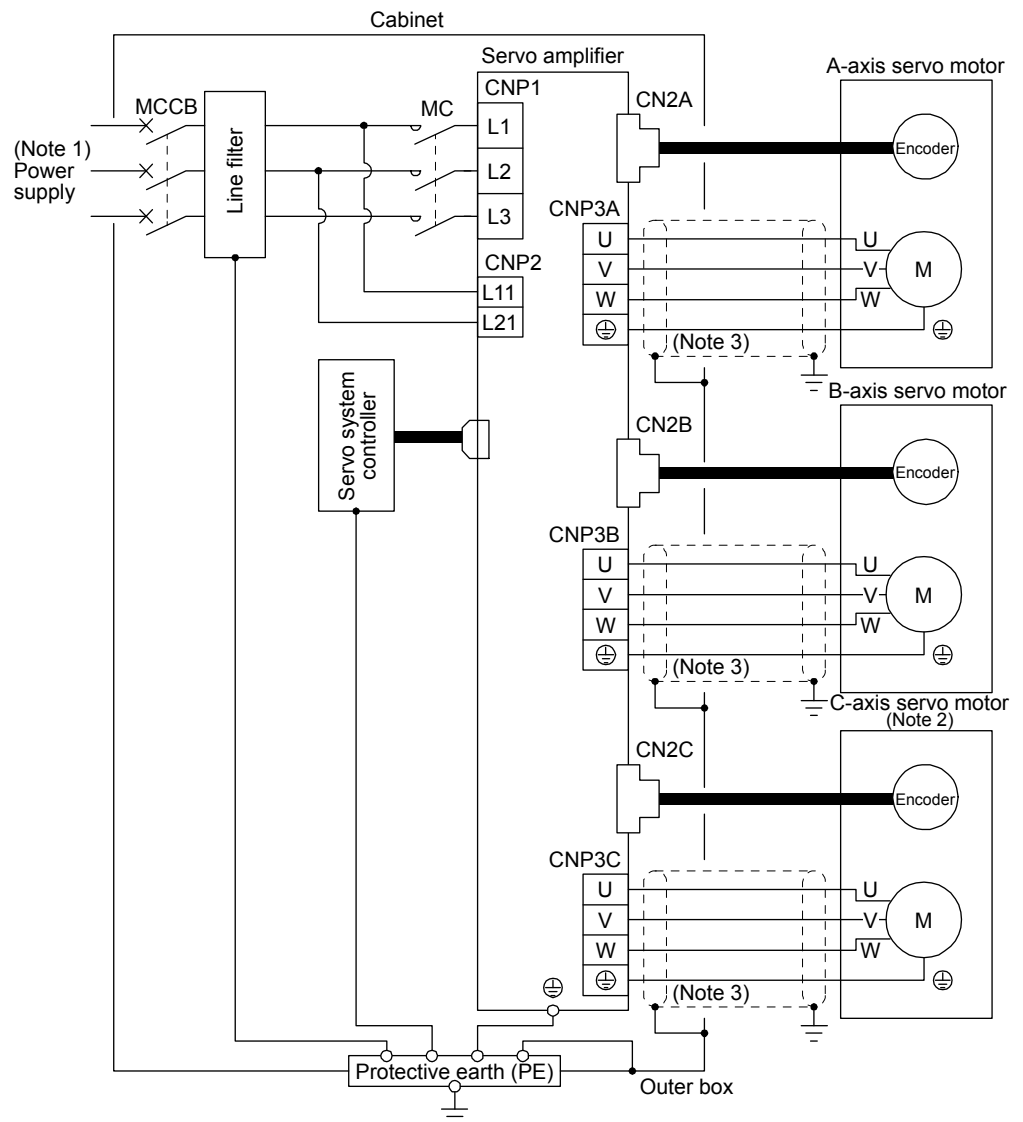

- Note 1. For power supply specifications, refer to section 1.3.
 Note 2. For the MR-J4 3-axis servo amplifier
 Note 3. Be sure to connect it to ⊕ of CNP3A, CNP3B, and CNP3C. Do not connect the wire directly to the protective earth of the cabinet.

4. STARTUP

4. STARTUP



WARNING

- When executing a test run, follow the notice and procedures in this instruction manual. Otherwise, it may cause a malfunction, damage to the machine, or injury.
- Do not operate the switches with wet hands. Otherwise, it may cause an electric shock.



CAUTION

- Before starting operation, check the parameters. Improper settings may cause some machines to operate unexpectedly.
- The servo amplifier heat sink, regenerative resistor, servo motor, etc., may be hot while the power is on and for some time after power-off. Take safety measures such as providing covers to avoid accidentally touching them by hands and parts such as cables.
- During operation, never touch the rotor of the servo motor. Otherwise, it may cause injury.
- Before wiring, switch operation, etc., eliminate static electricity. Otherwise, it may cause a malfunction.

POINT

- When you use a linear servo motor, replace the following words in the left to the words in the right.
Load to motor inertia ratio → Load to motor mass ratio
Torque → Thrust
(Servo motor) speed → (Linear servo motor) speed

4. STARTUP

4.1 Switching power on for the first time

When switching power on for the first time, follow this section to make a startup.

4.1.1 Startup procedure

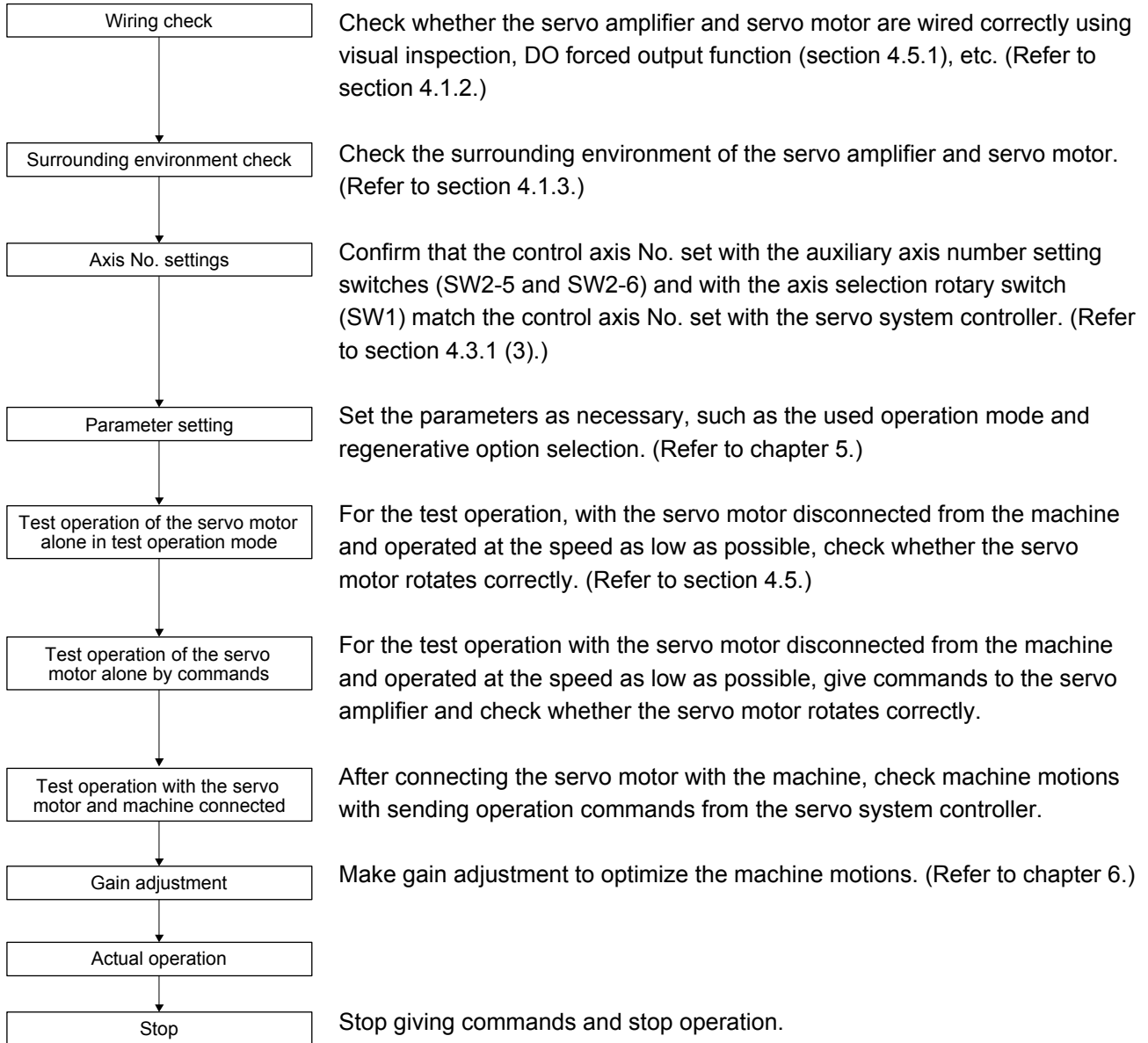

4. STARTUP

4.1.2 Wiring check

(1) Power supply system wiring

Before switching on the main circuit and control circuit power supplies, check the following items.

(a) Power supply system wiring

The power supplied to the power input terminals (L1/L2/L3/L11/L21) of the servo amplifier should satisfy the defined specifications. (Refer to section 1.3.)

(b) Connection of servo amplifier and servo motor

- 1) The CNP3A, CNP3B, or CNP3C connector should be connected to each A-axis, B-axis, or C-axis servo motor. The servo amplifier power output (U/V/W) should match in phase with the servo motor power input terminals (U/V/W).

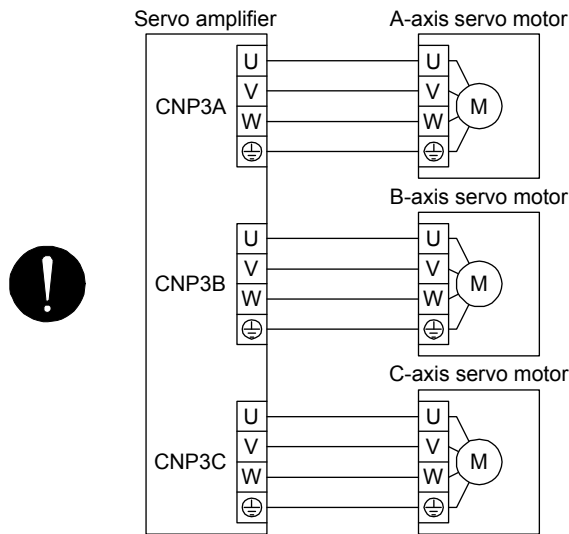

- 2) The power supplied to the servo amplifier should not be connected to the power outputs (U/V/W). Otherwise, the servo amplifier and servo motor will fail.

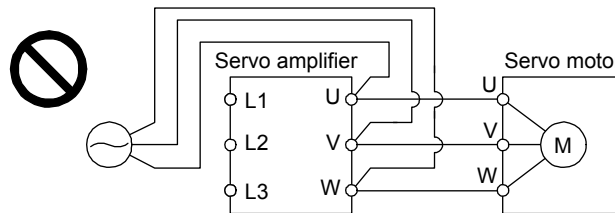

- 3) The grounding terminal of the servo motor should be connected to the PE terminal of the CNP3_ connector of the servo amplifier.

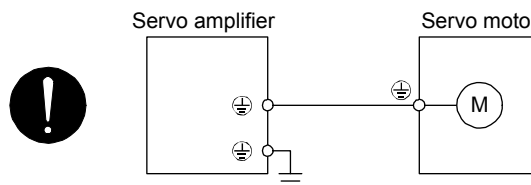

- 4) The CN2A, CN2B, or CN2C connector should be connected using encoder cables securely to each A-axis, B-axis, or C-axis encoder of the servo motors.

4. STARTUP

- (c) When you use an option and auxiliary equipment
 When you use a regenerative option
- The regenerative option wire should be connected between P+ terminal and C terminal.
 - Twisted wires should be used. (Refer to section 11.2.4.)

(2) I/O signal wiring

- (a) The I/O signals should be connected correctly.
 Use DO forced output to forcibly turn on/off the pins of the CN3 connector. You can use this function to check the wiring. In this case, switch on the control circuit power supply only.
 Refer to section 3.2 for details of I/O signal connection.
- (b) 24 V DC or higher voltage is not applied to the pins of the CN3 connector.
- (c) Plate and DOCOM of the CN3 connector is not shorted.

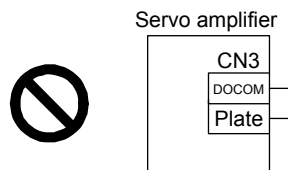

4.1.3 Surrounding environment

(1) Cable routing

- (a) The wiring cables should not be stressed.
- (b) The encoder cable should not be used in excess of its bending life. (Refer to section 10.4.)
- (c) The connector of the servo motor should not be stressed.

(2) Environment

Signal cables and power cables are not shorted by wire offcuts, metallic dust or the like.

4.2 Startup

| POINT | |
|-------------------------------------------|----------------------------------------------------------------------------------------------------------------------------------------------------------------------------------------------------------------------------------------------------------------------------------------------------------------------------------------------------------|
| ● | The controller recognizes MR-J4 2-axis servo amplifiers as two servo amplifiers and 3-axis servo amplifiers as three servo amplifiers. For this reason, select "MR-J4-B" for each of the A-axis, the B-axis, and the C-axis. The following table shows the servo amplifier settings in the controller when the MR-J4 multi-axis servo amplifier is used. |
| Compatible controller | Servo amplifier selection |
| Motion controller (R_MTCPU/Q17_DSCPU) | Select "MR-J4-B" in the system setting screen. |
| Simple motion module (RD77MS_/QD77MS_) | Select "MR-J4-B" in "Servo series" [Pr. 100] of the servo parameter. |

Connect the servo motor with a machine after confirming that the servo motor operates properly alone.

4. STARTUP

(1) Power on

When the main and control circuit power supplies are turned on, "b01" (for the first axis) appears on the servo amplifier display.

When the absolute position detection system is used in a rotary servo motor, first power-on results in [AL. 25 Absolute position erased] and the servo-on cannot be ready. The alarm can be deactivated by then switching power off once and on again.

Also, if power is switched on at the servo motor speed of 3000 r/min or higher, position mismatch may occur due to external force or the like. Power must therefore be switched on when the servo motor is at a stop.

(2) Parameter setting

| POINT |
|--------------------------------------------------------------------------------------------------------------------------------------------------------------------------------------------------------------------------------------------------------------------------------------------------------------|
| ● The following encoder cables are of four-wire type. When using any of these encoder cables, set [Pr. PC04] to "1 _ _ _" to select the four-wire type. Incorrect setting will result in [AL. 16 Encoder initial communication error 1]. MR-EKCBL30M-L MR-EKCBL30M-H MR-EKCBL40M-H MR-EKCBL50M-H |

Set the parameters according to the structure and specifications of the machine. Refer to chapter 5 for details.

After setting the above parameters, switch power off as necessary. Then switch power on again to enable the parameter values.

(3) Servo-on

Enable the servo-on with the following procedure.

(a) Switch on main circuit power supply and control circuit power supply.

(b) Transmit the servo-on command with the servo system controller.

When the servo-on status is enabled, the servo amplifier is ready to operate and the servo motor is locked.

(4) Home position return

Always perform home position return before starting positioning operation.

4. STARTUP

(5) Stop

Turn off the servo-on command after the servo motor has stopped, and then switch the power off.

If any of the following situations occurs, the servo amplifier suspends the running of the servo motor and brings it to a stop.

Refer to section 3.10 for the servo motor with an electromagnetic brake.

| | Operation/command | Stopping condition |
|-------------------------|-------------------------|---------------------------------------------------------------------------------------------------------------------------------------------------------------------------------------------|
| Servo system controller | Servo-off command | The base circuit is shut off and the servo motor coasts. |
| | Ready-off command | The base circuit is shut off and the dynamic brake operates to bring the servo motor to a stop. |
| | Forced stop command | The servo motor decelerates to a stop with the command. [AL. E7 Controller forced stop warning] occurs. |
| Servo amplifier | Alarm occurrence | The servo motor decelerates to a stop with the command. With some alarms, however, the dynamic brake operates to bring the servo motor to a stop. (Refer to section 8. (Note)) |
| | EM2 (Forced stop 2) off | The servo motor decelerates to a stop with the command. [AL. E6 Servo forced stop warning] occurs. EM2 has the same device as EM1 in the torque control mode. Refer to section 3.5 for EM1. |
| | STO (STO1, STO2) off | The base circuit is shut off and the dynamic brake operates to bring the servo motor to a stop. |

Note. Only a list of alarms and warnings is listed in chapter 8. Refer to "MELSERVO-J4 Servo Amplifier Instruction Manual (Troubleshooting)" for details of alarms and warnings.

4.3 Switch setting and display of the servo amplifier

Switching to the test operation mode, deactivating control axes, and setting control axis No. are enabled with switches on the servo amplifier.

On the servo amplifier display (three-digit, seven-segment LED), check the status of communication with the servo system controller at power-on, and the axis number, and diagnose a malfunction at occurrence of an alarm.

4.3.1 Switches

WARNING

- When switching the axis selection rotary switch (SW1) and auxiliary axis number setting switch (SW2), use an insulated screw driver. Do not use a metal screw driver. Touching patterns on electronic boards, lead of electronic parts, etc. may cause an electric shock.

POINT

- Turning "ON (up)" all the control axis setting switches (SW2) enables an operation mode for manufacturer setting and displays "off". The mode is not available. Set the control axis setting switches (SW2) correctly according to this section.
- Cycling the main circuit power supply and control circuit power supply enables the setting of each switch.

4. STARTUP

The following explains the test operation select switch, the disabling control axis switches, auxiliary axis number setting switches, and the axis selection rotary switch.

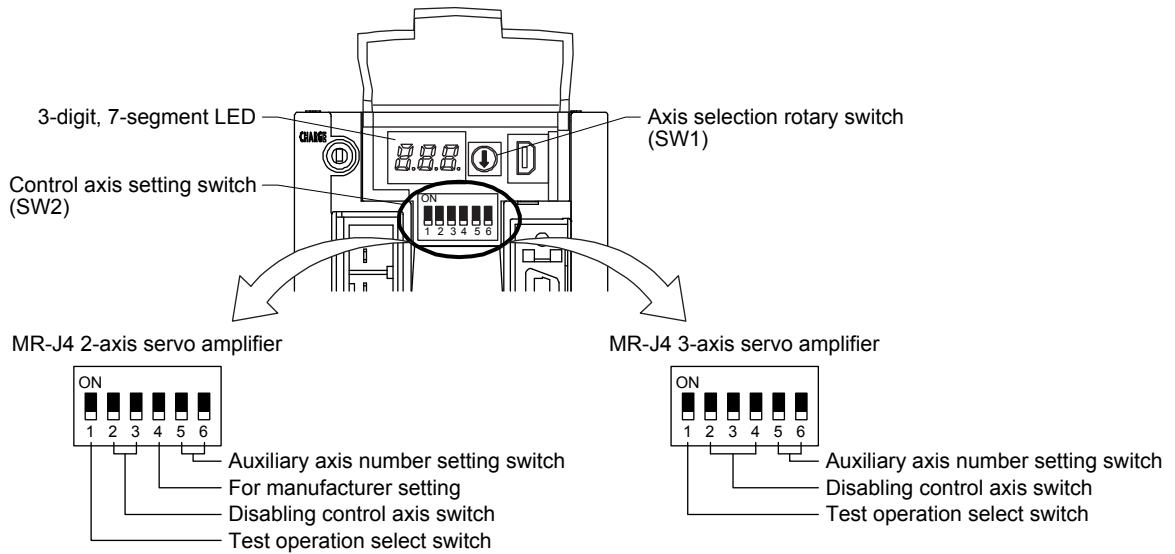

(1) Test operation select switch (SW2-1)

To use the test operation mode, turn "ON (up)" the switch. Turning "ON (up)" the switch enables the test operation mode for all axes. In the test operation mode, the functions such as JOG operation, positioning operation, and machine analyzer are available with MR Configurator2. Before turning "ON (up)" the test operation select switch, turn "OFF (down)" the disabling control axis switches.

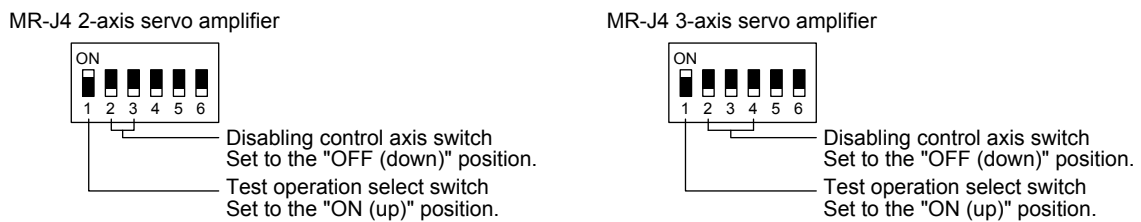

(2) Disabling control axis switches (SW2-2, SW2-3, and SW2-4)

Turning "ON (up)" a disabling control axis switch disables the corresponding servo motor. The servo motor will be disabled-axis status and will not be recognized by the controller. The following shows the disabling control axis switches for each axis.

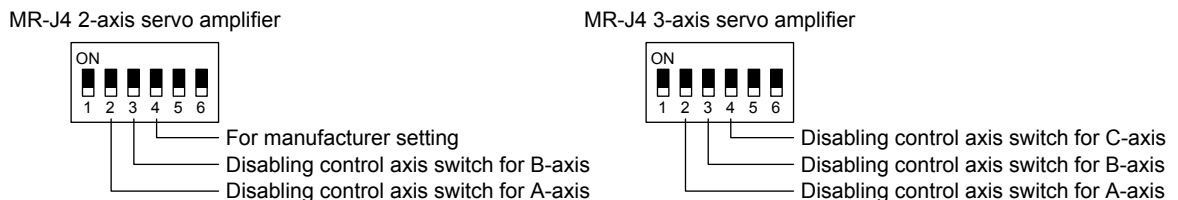

Disable the axis that you do not use. Set them from the last axis to the first axis in order. When only the first axis is disabled, [AL. 11 Switch setting error] occurs. The following lists show the enabled axes that the controller recognizes and the disabled axes that the controller do not recognize.

4. STARTUP

MR-J4 2-axis servo amplifier

MR-J4 3-axis servo amplifier

| Disabling control axis switch | A-axis | B-axis | Disabling control axis switch | A-axis | B-axis | C-axis | Disabling control axis switch | A-axis | B-axis | C-axis |
|-------------------------------|------------------|----------|-------------------------------|----------|----------|----------|-------------------------------|------------------|--------|--------|
| | Enabled | Enabled | | Enabled | Enabled | Enabled | | [AL. 11] occurs. | | |
| | Enabled | Disabled | | Enabled | Enabled | Disabled | | | | |
| | Disabled | Disabled | | Enabled | Disabled | Disabled | | | | |
| | [AL. 11] occurs. | | | Disabled | Disabled | Disabled | | | | |

(3) Switches for setting control axis No.

| |
|----------------------------------------------------------------------------------------------------------------------------------------------------------------------------------------------------------------------------------------------------------------------------------------------------------------------------------------------------------------------------------------------------------------------------------------------------------------------------------------------------------------------------------------------------------------------------------------------------------------------------------------------------------------------------------------------------------------------------------------------------------------|
| POINT |
| <ul style="list-style-type: none"> ● The control axis No. set to the auxiliary axis number setting switches (SW2-5 and SW2-6) and the axis selection rotary switch (SW1) should be the same as the one set to the servo system controller. The number of the axes you can set depends on the servo system controller. ● For setting the axis selection rotary switch, use a flat-blade screwdriver with the blade edge width of 2.1 mm to 2.3 mm and the blade edge thickness of 0.6 mm to 0.7 mm. ● When the test operation mode is selected with the test operation select switch (SW2-1), the SSCNET III/H communication for the servo amplifier in the test operation mode and the following servo amplifiers is blocked. |

You can set the control axis No. between 1 and 64 by using auxiliary axis number setting switches with the axis selection rotary switch. (Refer to (3) (c) in this section.)

If the same numbers are set to different control axes in a single communication system, the system will not operate properly. The control axes may be set independently of the SSCNET III cable connection sequence. The following shows the description of each switch.

(a) Auxiliary axis number setting switches (SW2-5 and SW2-6)
Turning these switches "ON (up)" enables you to set the axis No. 17 or more.

(b) Axis selection rotary switch (SW1)
You can set the control axis No. between 1 and 64 by using auxiliary axis number setting switches with the axis selection rotary switch. (Refer to (3) (c) in this section.)

Axis selection rotary switch (SW1)

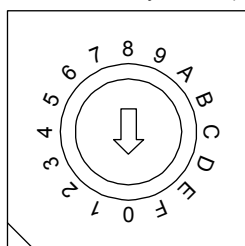

4. STARTUP

(c) Switch combination list for the control axis No. setting

| POINT |
|-----------------------------------------------------------------------------------------------------------------------------------------|
| <p>● Set control axis Nos. for one system. For details of the control axis No., refer to the servo system controller user's manual.</p> |

The following lists show the setting combinations of the auxiliary axis number setting switches and the axis selection rotary switch.

1) MR-J4 2-axis servo amplifier

The control axis No. of A-axis is set as 1 to 63 and B-axis is set as 2 to 64.

| Auxiliary axis number setting switch | Axis selection rotary switch | Control axis No. | |
|--------------------------------------|------------------------------|------------------|--------|
| | | A-axis | B-axis |
| | 0 | 1 | 2 |
| | 1 | 2 | 3 |
| | 2 | 3 | 4 |
| | 3 | 4 | 5 |
| | 4 | 5 | 6 |
| | 5 | 6 | 7 |
| | 6 | 7 | 8 |
| | 7 | 8 | 9 |
| | 8 | 9 | 10 |
| | 9 | 10 | 11 |
| | A | 11 | 12 |
| | B | 12 | 13 |
| | C | 13 | 14 |
| | D | 14 | 15 |
| | E | 15 | 16 |
| | F | 16 | 17 |



| Auxiliary axis number setting switch | Axis selection rotary switch | Control axis No. | |
|--------------------------------------|------------------------------|------------------|--------|
| | | A-axis | B-axis |
| | 0 | 17 | 18 |
| | 1 | 18 | 19 |
| | 2 | 19 | 20 |
| | 3 | 20 | 21 |
| | 4 | 21 | 22 |
| | 5 | 22 | 23 |
| | 6 | 23 | 24 |
| | 7 | 24 | 25 |
| | 8 | 25 | 26 |
| | 9 | 26 | 27 |
| | A | 27 | 28 |
| | B | 28 | 29 |
| | C | 29 | 30 |
| | D | 30 | 31 |
| | E | 31 | 32 |
| | F | 32 | 33 |



| Auxiliary axis number setting switch | Axis selection rotary switch | Control axis No. | |
|--------------------------------------|------------------------------|------------------|--------|
| | | A-axis | B-axis |
| | 0 | 33 | 34 |
| | 1 | 34 | 35 |
| | 2 | 35 | 36 |
| | 3 | 36 | 37 |
| | 4 | 37 | 38 |
| | 5 | 38 | 39 |
| | 6 | 39 | 40 |
| | 7 | 40 | 41 |
| | 8 | 41 | 42 |
| | 9 | 42 | 43 |
| | A | 43 | 44 |
| | B | 44 | 45 |
| | C | 45 | 46 |
| | D | 46 | 47 |
| | E | 47 | 48 |
| | F | 48 | 49 |



| Auxiliary axis number setting switch | Axis selection rotary switch | Control axis No. | |
|--------------------------------------|------------------------------|------------------|--------|
| | | A-axis | B-axis |
| | 0 | 49 | 50 |
| | 1 | 50 | 51 |
| | 2 | 51 | 52 |
| | 3 | 52 | 53 |
| | 4 | 53 | 54 |
| | 5 | 54 | 55 |
| | 6 | 55 | 56 |
| | 7 | 56 | 57 |
| | 8 | 57 | 58 |
| | 9 | 58 | 59 |
| | A | 59 | 60 |
| | B | 60 | 61 |
| | C | 61 | 62 |
| | D | 62 | 63 |
| | E | 63 | 64 |
| | F | (Note) | |



Note. When B-axis is set as disabled-axis, A-axis is used as 64 axes. When B-axis is not set as non-axis, [AL. 11 Switch setting error] occurs.

4. STARTUP

2) MR-J4 3-axis servo amplifier

The control axis No. of A-axis is set as 1 to 62, B-axis is set as 2 to 63, and C-axis is set as 3 to 64.

| Auxiliary axis number setting switch | Axis selection rotary switch | Control axis No. | | |
|--------------------------------------|------------------------------|------------------|--------|--------|
| | | A-axis | B-axis | C-axis |
| | 0 | 1 | 2 | 3 |
| | 1 | 2 | 3 | 4 |
| | 2 | 3 | 4 | 5 |
| | 3 | 4 | 5 | 6 |
| | 4 | 5 | 6 | 7 |
| | 5 | 6 | 7 | 8 |
| | 6 | 7 | 8 | 9 |
| | 7 | 8 | 9 | 10 |
| | 8 | 9 | 10 | 11 |
| | 9 | 10 | 11 | 12 |
| | A | 11 | 12 | 13 |
| | B | 12 | 13 | 14 |
| | C | 13 | 14 | 15 |
| | D | 14 | 15 | 16 |
| | E | 15 | 16 | 17 |
| | F | 16 | 17 | 18 |

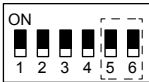

| Auxiliary axis number setting switch | Axis selection rotary switch | Control axis No. | | |
|--------------------------------------|------------------------------|------------------|--------|--------|
| | | A-axis | B-axis | C-axis |
| | 0 | 17 | 18 | 19 |
| | 1 | 18 | 19 | 20 |
| | 2 | 19 | 20 | 21 |
| | 3 | 20 | 21 | 22 |
| | 4 | 21 | 22 | 23 |
| | 5 | 22 | 23 | 24 |
| | 6 | 23 | 24 | 25 |
| | 7 | 24 | 25 | 26 |
| | 8 | 25 | 26 | 27 |
| | 9 | 26 | 27 | 28 |
| | A | 27 | 28 | 29 |
| | B | 28 | 29 | 30 |
| | C | 29 | 30 | 31 |
| | D | 30 | 31 | 32 |
| | E | 31 | 32 | 33 |
| | F | 32 | 33 | 34 |



| Auxiliary axis number setting switch | Axis selection rotary switch | Control axis No. | | |
|--------------------------------------|------------------------------|------------------|--------|--------|
| | | A-axis | B-axis | C-axis |
| | 0 | 33 | 34 | 35 |
| | 1 | 34 | 35 | 36 |
| | 2 | 35 | 36 | 37 |
| | 3 | 36 | 37 | 38 |
| | 4 | 37 | 38 | 39 |
| | 5 | 38 | 39 | 40 |
| | 6 | 39 | 40 | 41 |
| | 7 | 40 | 41 | 42 |
| | 8 | 41 | 42 | 43 |
| | 9 | 42 | 43 | 44 |
| | A | 43 | 44 | 45 |
| | B | 44 | 45 | 46 |
| | C | 45 | 46 | 47 |
| | D | 46 | 47 | 48 |
| | E | 47 | 48 | 49 |
| | F | 48 | 49 | 50 |

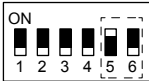

| Auxiliary axis number setting switch | Axis selection rotary switch | Control axis No. | | |
|--------------------------------------|------------------------------|------------------|--------|--------|
| | | A-axis | B-axis | C-axis |
| | 0 | 49 | 50 | 51 |
| | 1 | 50 | 51 | 52 |
| | 2 | 51 | 52 | 53 |
| | 3 | 52 | 53 | 54 |
| | 4 | 53 | 54 | 55 |
| | 5 | 54 | 55 | 56 |
| | 6 | 55 | 56 | 57 |
| | 7 | 56 | 57 | 58 |
| | 8 | 57 | 58 | 59 |
| | 9 | 58 | 59 | 60 |
| | A | 59 | 60 | 61 |
| | B | 60 | 61 | 62 |
| | C | 61 | 62 | 63 |
| | D | 62 | 63 | 64 |
| | E | (Note 1) | | |
| | F | (Note 2) | | |

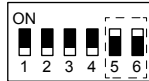

Note 1. When C-axis is set as disabled-axis, A-axis is used as 63 axes and B-axis is used as 64-axes. When C-axis is not set as disabled-axis, [AL. 11 Switch setting error] occurs.

Note 2. When B-axis and C-axis are set as disabled-axes, A-axis is used as 64 axes. When B-axis and C-axis are not set as disabled-axes, [AL. 11 Switch setting error] occurs.

4. STARTUP

4.3.2 Scrolling display

Displaying the status of each axis in rotation enables you to check the status of all axes.

(1) Normal display

When there is no alarm, the status of all axes are displayed in rotation.

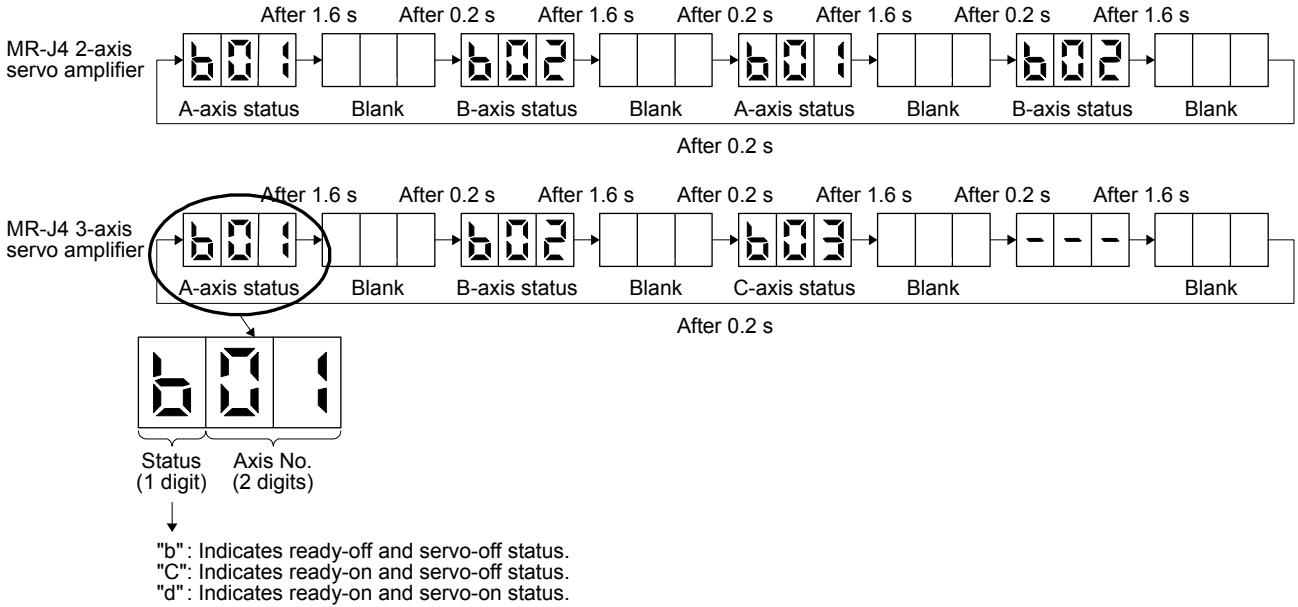

(2) Alarm display

When an alarm occurs, the alarm number (two digits) and the alarm detail (one digit) are displayed following the status display. For example, the following shows when [AL. 16 Encoder initial communication error 1] is occurring at the A-axis, and [AL. 32 Overcurrent] is occurring at the B-axis simultaneously.

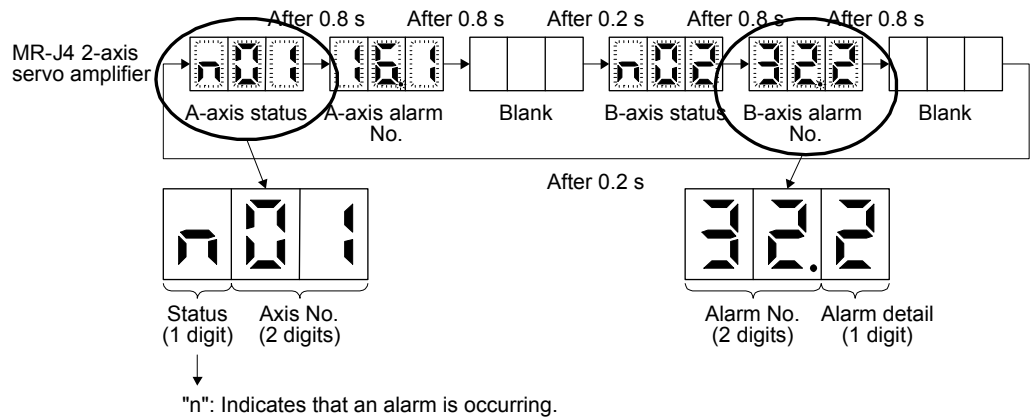

4. STARTUP

4.3.3 Status display of an axis

(1) Display sequence

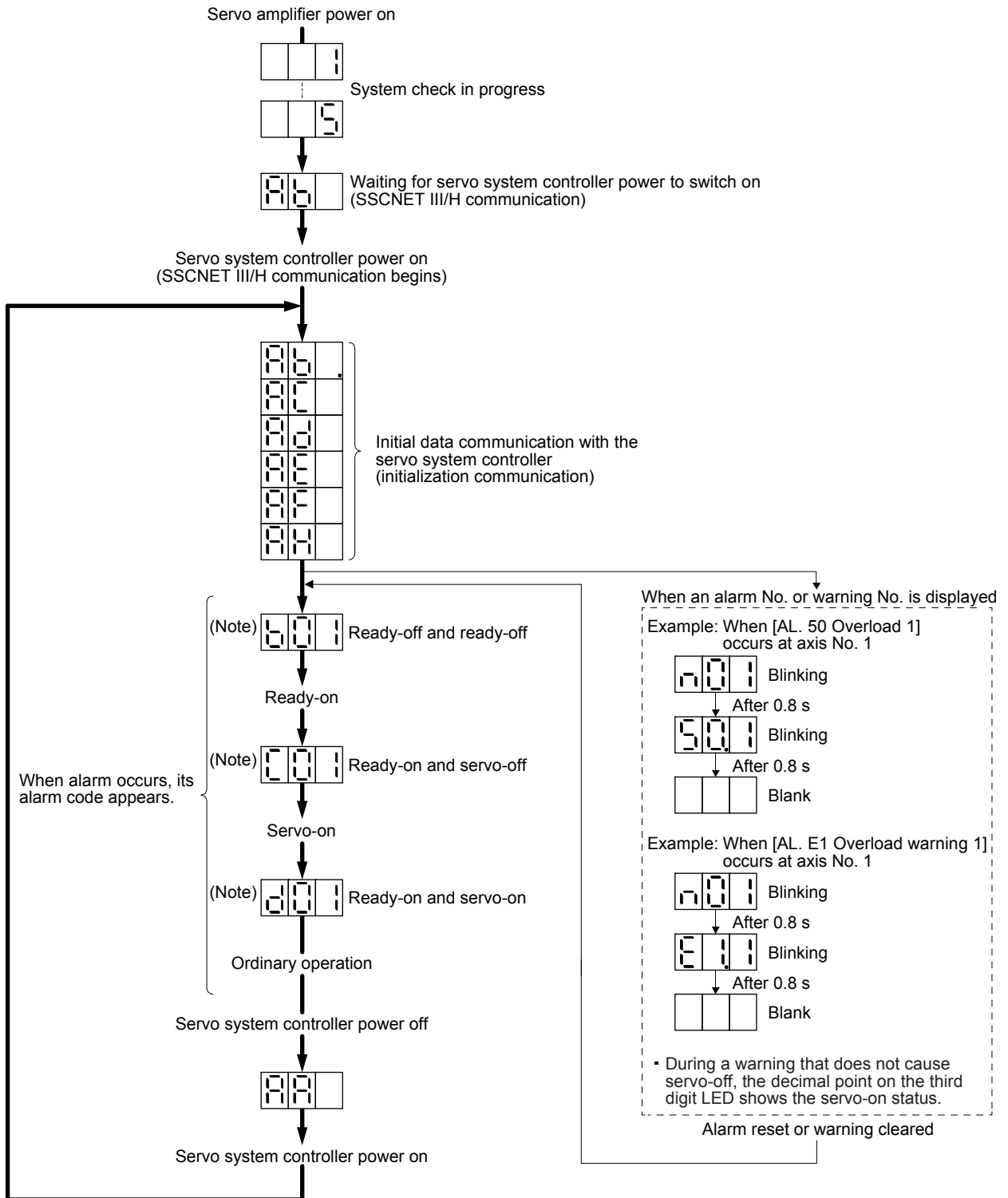

Note.











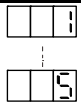





| | | | |
|-----|-----|-----|----|
| 001 | 002 | ... | 64 |
|-----|-----|-----|----|

 The segment of the last 2 digits shows the axis number.

| | | |
|------------|------------|-------------|
| Axis No. 1 | Axis No. 2 | Axis No. 64 |
|------------|------------|-------------|

4. STARTUP

(2) Indication list

| Indication | Status | Description |
|----------------------------------------------------------------------------------------------------------------------------------------------------------------------------------------------------------------------------------------------------------------------------|---------------------------------|---------------------------------------------------------------------------------------------------------------------------------------------------------------------------------------------------------------------------------------------------------------------------------------------------------------------------------------------------------------------------------------------------------------------------------------------------------------------------------------------------------------------------------------------------------------------------------------------------------------------------------------------------------------------|
|  | Initializing | System check in progress |
|  | Initializing | <ul style="list-style-type: none"> Power of the servo amplifier was switched on at the condition that the power of the servo system controller is off. The control axis No. set to the auxiliary axis number setting switches (SW2-5 and SW2-6) and the axis selection rotary switch (SW1) do not match the one set to the servo system controller. A servo amplifier malfunctioned, or communication error occurred with the servo system controller or the previous axis servo amplifier. In this case, the indication changes as follows. "Ab" → "AC" → "Ad" → "Ab" The servo system controller is malfunctioning. |
|  | Initializing | During initial setting for communication specifications |
|  | Initializing | Initial setting for communication specifications completed, and then it synchronized with servo system controller. |
|  | Initializing | During initial parameter setting communication with servo system controller |
|  | Initializing | During the servo motor/encoder information and telecommunication with servo system controller |
|  | Initializing | During initial signal data communication with servo system controller |
|  | Initializing completion | The process for initial data communication with the servo system controller is completed. |
|  | Initializing standby | The power supply of servo system controller is turned off during the power supply of servo amplifier is on. |
| (Note 1)  | Ready-off | The ready off signal from the servo system controller was received. |
| (Note 1)  | Servo-on | The ready off signal from the servo system controller was received. |
| (Note 1)  | Servo-off | The ready off signal from the servo system controller was received. |
| (Note 2)  | Alarm/warning | The alarm No. and the warning No. that occurred is displayed. (Refer to chapter 8. (Note 4)) |
|  | CPU error | CPU watchdog error has occurred. |
| (Note 1)    | (Note 3) Test operation mode | JOG operation, positioning operation, program operation, output signal (DO) forced output, or motor-less operation was set. |

Note 1. The meanings of ## are listed below.

| ## | Description |
|----|-------------|
| 01 | Axis No. 1 |
| to | to |
| 64 | Axis No. 64 |

- *** indicates the alarm No. and the warning No. "A" in the third digit indicates the A-axis, "B" indicates the B-axis, and "C" indicates the C-axis.
- Only a list of alarms and warnings is listed in chapter 8. Refer to "MELSERVO-J4 Servo Amplifier Instruction Manual (Troubleshooting)" for details of alarms and warnings.

4. STARTUP

4.4 Test operation

Before starting actual operation, perform test operation to make sure that the machine operates normally. Refer to section 4.2 for the power on and off methods of the servo amplifier.

POINT

- If necessary, verify controller program by using motor-less operation. Refer to section 4.5.2 for the motor-less operation.

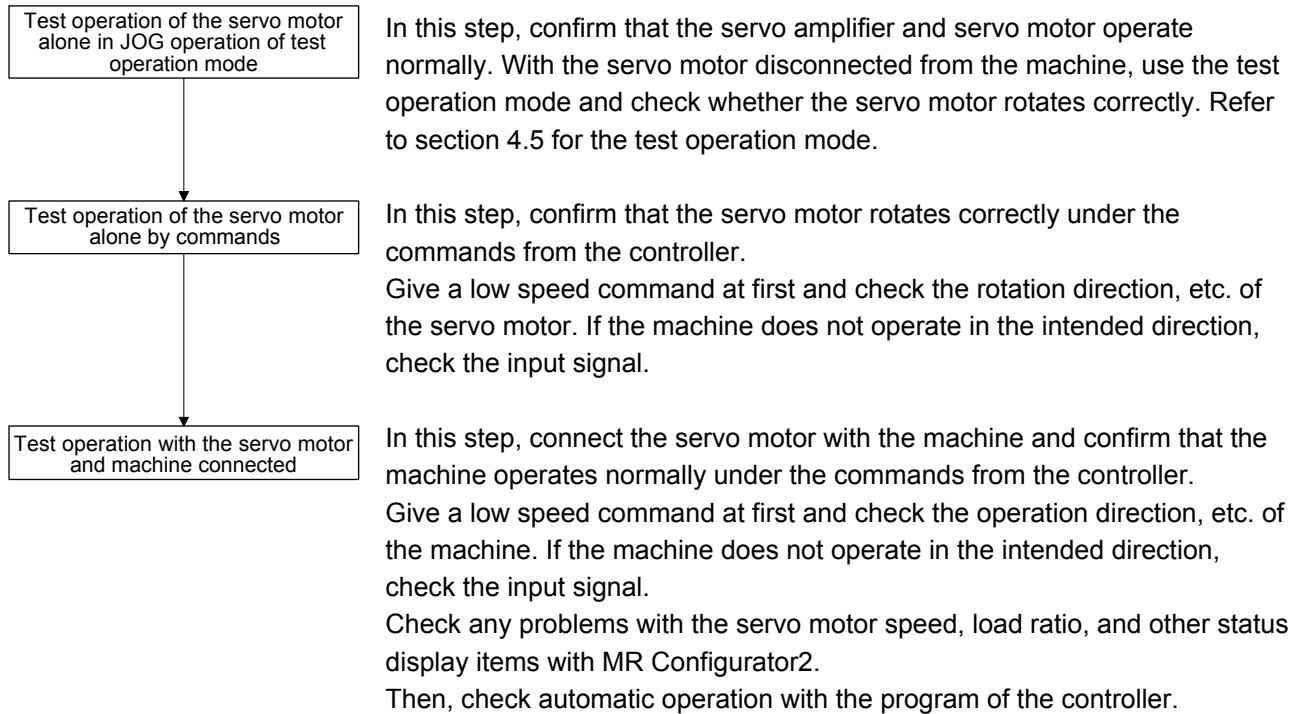

4.5 Test operation mode



CAUTION

- The test operation mode is designed for checking servo operation. It is not for checking machine operation. Do not use this mode with the machine. Always use the servo motor alone.
- If the servo motor operates abnormally, use EM2 (Forced stop 2) to stop it.

POINT

- The content described in this section indicates that the servo amplifier and a personal computer are directly connected.

By using a personal computer and MR Configurator2, you can execute jog operation, positioning operation, DO forced output program operation without connecting the servo system controller.

4. STARTUP

4.5.1 Test operation mode in MR Configurator2

| POINT |
|-----------------------------------------------------------------------------------------------------------------------------------------------------------------------------------------------------------------------------------------------------------------------------------------------------------------------------------------------------------------------------------------------------------------------|
| <ul style="list-style-type: none"> ● All axes will be in the test operation mode for the multi-axis servo amplifier. Although only one axis is active in the mode. ● When the test operation mode is selected with the test operation select switch (SW2-1), the SSCNET III/H communication for the servo amplifier in the test operation mode and the following servo amplifiers is blocked. |

(1) Test operation mode

(a) Jog operation

Jog operation can be performed without using the servo system controller. Use this operation with the forced stop reset. This operation may be used independently of whether the servo is on or off and whether the servo system controller is connected or not.

Exercise control on the jog operation screen of MR Configurator2.

1) Operation pattern

| Item | Default value | Setting range |
|----------------------------------------------|---------------|-----------------|
| Speed [r/min] | 200 | 0 to max. speed |
| Acceleration/deceleration time constant [ms] | 1000 | 0 to 50000 |

2) Operation method

- When the check box of "Rotation only while the CCW or CW button is being pushed." is checked.

| Operation | Screen control |
|------------------------|---------------------------------|
| Forward rotation start | Keep pressing "Forward". |
| Reverse rotation start | Keep pressing "Reverse". |
| Stop | Release "Forward" or "Reverse". |
| Forced stop | Click "Forced stop". |

- When the check box of "Rotation only while the CCW or CW button is being pushed." is not checked.

| Operation | Screen control |
|------------------------|----------------------|
| Forward rotation start | Click "Forward". |
| Reverse rotation start | Click "Reverse". |
| Stop | Click "Stop". |
| Forced stop | Click "Forced stop". |

4. STARTUP

(b) Positioning operation

Positioning operation can be performed without using the servo system controller. Use this operation with the forced stop reset. This operation may be used independently of whether the servo is on or off and whether the servo system controller is connected or not.

Exercise control on the positioning operation screen of MR Configurator2.

1) Operation pattern

| Item | Default value | Setting range |
|----------------------------------------------|-----------------------------------|--------------------------------------------------------------------------------------------------------------------------------------------------|
| Travel distance [pulse] | 4000 | 0 to 99999999 |
| Speed [r/min] | 200 | 0 to max. speed |
| Acceleration/deceleration time constant [ms] | 1000 | 0 to 50000 |
| Repeat pattern | Fwd. rot. (CCW) to rev. rot. (CW) | Fwd. rot. (CCW) to rev. rot. (CW) Fwd. rot. (CCW) to fwd. rot. (CCW) Rev. rot. (CW) to fwd. rot. (CCW) Rev. rot. (CW) to rev. rot. (CW) |
| Dwell time [s] | 2.0 | 0.1 to 50.0 |
| Number of repeats [time] | 1 | 1 to 9999 |

2) Operation method

| Operation | Screen control |
|------------------------|----------------------|
| Forward rotation start | Click "Forward". |
| Reverse rotation start | Click "Reverse". |
| Pause | Click "Pause". |
| Stop | Click "Stop". |
| Forced stop | Click "Forced stop". |

(c) Program operation

Positioning operation can be performed in two or more operation patterns combined, without using the servo system controller. Use this operation with the forced stop reset. This operation may be used independently of whether the servo is on or off and whether the servo system controller is connected or not.

Exercise control on the program operation screen of MR Configurator2. For details, refer to Help of MR Configurator2.

| Operation | Screen control |
|-------------|----------------------|
| Start | Click "Start". |
| Pause | Click "Pause". |
| Stop | Click "Stop". |
| Forced stop | Click "Forced stop". |

(d) Output signal (DO) forced output

Output signals can be switched on/off forcibly independently of the servo status. Use this function for output signal wiring check, etc. Exercise control on the DO forced output screen of MR Configurator2.

4. STARTUP

(2) Operation procedure

- 1) Turn off the power.
- 2) Turn "ON (up)" SW2-1.

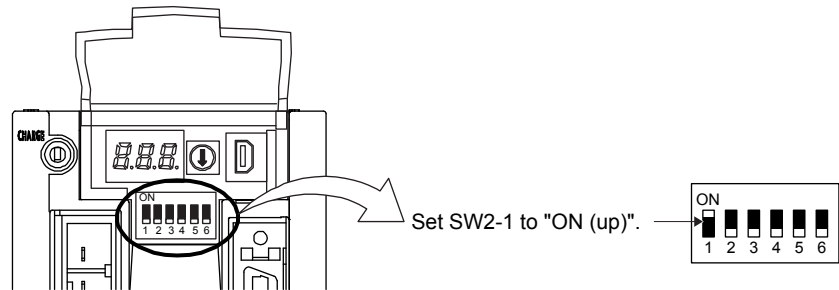

Turning "ON (up)" SW2-1 during power-on will not start the test operation mode.

3) Turn on the servo amplifier.

When initialization is completed, the decimal point on the first digit will blink.

Example: MR-J4 2-axis servo amplifier

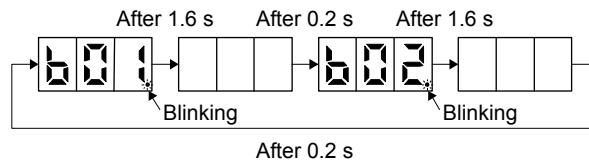

When an alarm or warning also occurs during the test operation, the decimal point will blink.

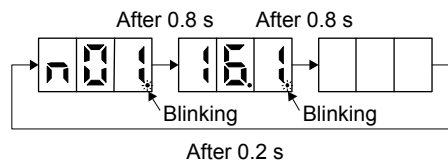

4) Start operation with the personal computer.

4.5.2 Motor-less operation in controller

| POINT |
|----------------------------------------------------------------------------------------------------------------------------------------------------------------------------------------------------------------------------------------------------------------------------------------------------------------------------------------------------------------------------------------------------------------------|
| <ul style="list-style-type: none"> ● Use motor-less operation which is available by making the servo system controller parameter setting. ● Connect the servo amplifier with the servo system controller before the motor-less operation. ● The motor-less operation is not used in the fully closed loop control mode, linear servo motor control mode, and DD motor control mode. |

4. STARTUP

(1) Motor-less operation

Without connecting a servo motor to servo amplifier, output signals or status displays can be provided in response to the servo system controller commands as if the servo motor is actually running. This operation may be used to check the servo system controller sequence. Use this operation with the forced stop reset. Use this operation with the servo amplifier connected to the servo system controller. To stop the motor-less operation, set the motor-less operation selection to "Disable" in the servo parameter setting of the servo system controller. When the power supply is turned on next time, motor-less operation will be disabled.

(a) Load conditions

| Load item | Condition |
|-----------------------------|-----------------------------------------------------------------|
| Load torque | 0 |
| Load to motor inertia ratio | [Pr. PB06 Load to motor inertia ratio/load to motor mass ratio] |

(b) Alarms

The following alarms and warning do not occur. However, the other alarms and warnings occur as when the servo motor is connected.

- [AL. 16 Encoder initial communication error 1]
- [AL. 1E Encoder initial communication error 2]
- [AL. 1F Encoder initial communication error 3]
- [AL. 20 Encoder normal communication error 1]
- [AL. 21 Encoder normal communication error 2]
- [AL. 25 Absolute position erased]
- [AL. 92 Battery cable disconnection warning]
- [AL. 9F Battery warning]

4. STARTUP

(2) Operation procedure

- 1) Set the servo amplifier to the servo-off status.
- 2) Set [Pr. PC05] to "___ 1", turn "OFF (down: normal condition side)" the test operation mode switch (SW2-1), and then turn on the power supply.

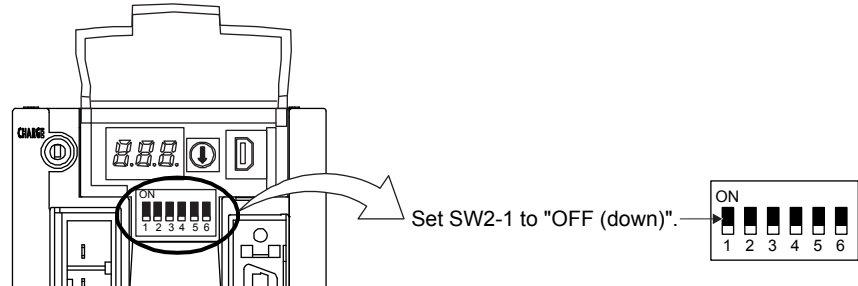

- 3) Start the motor-less operation with the servo system controller.
The display shows the following screen.

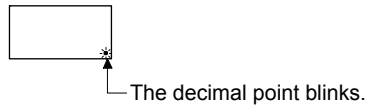

5. PARAMETERS

5. PARAMETERS

CAUTION

- Never make a drastic adjustment or change to the parameter values as doing so will make the operation unstable.
- Do not change the parameter settings as described below. Doing so may cause an unexpected condition, such as failing to start up the servo amplifier.
 - Changing the values of the parameters for manufacturer setting
 - Setting a value out of the range
 - Changing the fixed values in the digits of a parameter
- When you write parameters with the controller, make sure that the control axis No. of the servo amplifier is set correctly. Otherwise, the parameter settings of another axis may be written, possibly causing the servo amplifier to be an unexpected condition.

POINT

- The following parameters are not available with 200 W or more MR-J4W_ _B servo amplifiers.
 - [Pr. PC09 Analog monitor 1 output]
 - [Pr. PC10 Analog monitor 2 output]
 - [Pr. PC11 Analog monitor 1 offset]
 - [Pr. PC12 Analog monitor 2 offset]
 - [Pr. PC13 Analog monitor - Feedback position output standard data - Low]
 - [Pr. PC14 Analog monitor - Feedback position output standard data - High]
- The following parameters are not available with MR-J4W2-0303B6 servo amplifiers.
 - [Pr. PA02 Regenerative option]
 - [Pr. PA17 Servo motor series setting]
 - [Pr. PA18 Servo motor type setting]
 - [Pr. PA22 Position control composition selection]
 - [Pr. PC20 Function selection C-7]
 - [Pr. PC27 Function selection C-9]
 - [Pr. PE01 Fully closed loop function selection 1]
 - [Pr. PE03 Fully closed loop function selection 2]
 - [Pr. PE04 Fully closed loop control - Feedback pulse electronic gear 1 - Numerator]
 - [Pr. PE05 Fully closed loop control - Feedback pulse electronic gear 1 - Denominator]
 - [Pr. PE06 Fully closed loop control - Speed deviation error detection level]
 - [Pr. PE07 Fully closed loop control - Position deviation error detection level]
 - [Pr. PE08 Fully closed loop dual feedback filter]
 - [Pr. PE10 Fully closed loop function selection 3]
 - [Pr. PE34 Fully closed loop control - Feedback pulse electronic gear 2 - Numerator]
 - [Pr. PE35 Fully closed loop control - Feedback pulse electronic gear 2 - Denominator]
- Linear servo motor/DD motor setting parameters ([Pr. PL_ _]) cannot be used with MR-J4W2-0303B6 servo amplifiers.
- When you connect the amplifier to a servo system controller, servo parameter values of the servo system controller will be written to each parameter.
- Setting may not be made to some parameters and their ranges depending on the servo system controller model, servo amplifier software version, and MR Configurator2 software version. For details, refer to the servo system controller user's manual.

5. PARAMETERS

5.1 Parameter list

| POINT | |
|-------|-----------------------------------------------------------------------------------------------------------------------------------------------------------------------------------------------------------------------------------------------------------------------------------------------------------------------------------------------------------------------------------------------------------------------------------------------------------------------------------------------------------------------------------------------------------------------------------------------------------------------------------------------------------------------------------------------------------------------------------------------------------------------------------------------------------------------------------------------------------------------------------------------------------------------------------------------------------------------------------------------------------------------------------------------------------------------------------------------------------------------------------------------------------------------------------------------------------|
| | <ul style="list-style-type: none">● The parameter whose symbol is preceded by * is enabled with the following conditions:<ul style="list-style-type: none">*: After setting the parameter, cycle the power or reset the controller.** : After setting the parameter, cycle the power.● How to set parameters<ul style="list-style-type: none">Each: Set parameters for each axis of A, B, and C.Common: Set parameters for common axis of A, B, and C. Be sure to set the same value to all axes.● The same values are set as default for all axes.● Abbreviations of operation modes indicate the followings.<ul style="list-style-type: none">Standard: Standard (semi closed loop system) use of the rotary servo motorFull.: Fully closed loop system use of the rotary servo motorLin.: Linear servo motor use.D.D.: Direct drive (D.D.) motor use.For MR-J4W2-0306B6 servo amplifiers, the operation mode is available only in standard (semi closed loop system).● Setting an out of range value to each parameter will trigger [AL. 37 Parameter error]. |

5. PARAMETERS

5.1.1 Basic setting parameters ([Pr. PA_ _])

| No. | Symbol | Name | Initial value | Unit | Each/ Common | Operation mode | | | |
|------|--------|---------------------------------------------------------|---------------|-------------|--------------|-----------------------|-----------------------|-----------------------|-----------------------|
| | | | | | | Standard | Full. | Lin. | D.D. |
| PA01 | **STY | Operation mode | 1000h | | Each | <input type="radio"/> | <input type="radio"/> | <input type="radio"/> | <input type="radio"/> |
| PA02 | **REG | Regenerative option | 0000h | | Common | <input type="radio"/> | <input type="radio"/> | <input type="radio"/> | <input type="radio"/> |
| PA03 | *ABS | Absolute position detection system | 0000h | | Each | <input type="radio"/> | <input type="radio"/> | <input type="radio"/> | <input type="radio"/> |
| PA04 | *AOP1 | Function selection A-1 | 2000h | | Common | <input type="radio"/> | <input type="radio"/> | <input type="radio"/> | <input type="radio"/> |
| PA05 | | For manufacturer setting | 10000 | | | | | | |
| PA06 | | | 1 | | | | | | |
| PA07 | | | 1 | | | | | | |
| PA08 | ATU | Auto tuning mode | 0001h | | Each | <input type="radio"/> | <input type="radio"/> | <input type="radio"/> | <input type="radio"/> |
| PA09 | RSP | Auto tuning response | 16 | | Each | <input type="radio"/> | <input type="radio"/> | <input type="radio"/> | <input type="radio"/> |
| PA10 | INP | In-position range | 1600 | [pulse] | Each | <input type="radio"/> | <input type="radio"/> | <input type="radio"/> | <input type="radio"/> |
| PA11 | | For manufacturer setting | 1000.0 | | | | | | |
| PA12 | | | 1000.0 | | | | | | |
| PA13 | | | 0000h | | | | | | |
| PA14 | *POL | Rotation direction selection/travel direction selection | 0 | | Each | <input type="radio"/> | <input type="radio"/> | <input type="radio"/> | <input type="radio"/> |
| PA15 | *ENR | Encoder output pulses | 4000 | [pulse/rev] | Each | <input type="radio"/> | <input type="radio"/> | <input type="radio"/> | <input type="radio"/> |
| PA16 | *ENR2 | Encoder output pulses 2 | 1 | | Each | <input type="radio"/> | <input type="radio"/> | <input type="radio"/> | <input type="radio"/> |
| PA17 | **MSR | Servo motor series setting | 0000h | | Each | <input type="radio"/> | <input type="radio"/> | <input type="radio"/> | <input type="radio"/> |
| PA18 | **MTY | Servo motor type setting | 0000h | | Each | <input type="radio"/> | <input type="radio"/> | <input type="radio"/> | <input type="radio"/> |
| PA19 | *BLK | Parameter writing inhibit | 00ABh | | Each | <input type="radio"/> | <input type="radio"/> | <input type="radio"/> | <input type="radio"/> |
| PA20 | *TDS | Tough drive setting | 0000h | | Each | <input type="radio"/> | <input type="radio"/> | <input type="radio"/> | <input type="radio"/> |
| PA21 | *AOP3 | Function selection A-3 | 0001h | | Each | <input type="radio"/> | <input type="radio"/> | <input type="radio"/> | <input type="radio"/> |
| PA22 | **PCS | Position control composition selection | 0000h | | Each | <input type="radio"/> | <input type="radio"/> | <input type="radio"/> | <input type="radio"/> |
| PA23 | DRAT | Drive recorder arbitrary alarm trigger setting | 0000h | | Each | <input type="radio"/> | <input type="radio"/> | <input type="radio"/> | <input type="radio"/> |
| PA24 | AOP4 | Function selection A-4 | 0000h | | Each | <input type="radio"/> | <input type="radio"/> | <input type="radio"/> | <input type="radio"/> |
| PA25 | OTHOV | One-touch tuning - Overshoot permissible level | 0 | [%] | Each | <input type="radio"/> | <input type="radio"/> | <input type="radio"/> | <input type="radio"/> |
| PA26 | | For manufacturer setting | 0000h | | | | | | |
| PA27 | | | 0000h | | | | | | |
| PA28 | | | 0000h | | | | | | |
| PA29 | | | 0000h | | | | | | |
| PA30 | | | 0000h | | | | | | |
| PA31 | | | 0000h | | | | | | |
| PA32 | | | 0000h | | | | | | |

5. PARAMETERS

5.1.2 Gain/filter setting parameters ([Pr. PB_ _])

| No. | Symbol | Name | Initial value | Unit | Each/ Common | Operation mode | | | |
|------|--------|---------------------------------------------------------------------------------------|---------------|------------------------------------|--------------|-----------------------|-----------------------|-----------------------|-----------------------|
| | | | | | | Standard | Full. | Lin. | D.D. |
| PB01 | FILT | Adaptive tuning mode (adaptive filter II) | 0000h | | Each | <input type="radio"/> | <input type="radio"/> | <input type="radio"/> | <input type="radio"/> |
| PB02 | VRFT | Vibration suppression control tuning mode (advanced vibration suppression control II) | 0000h | | Each | <input type="radio"/> | <input type="radio"/> | <input type="radio"/> | <input type="radio"/> |
| PB03 | TFBGN | Torque feedback loop gain | 18000 | [rad/s] | Each | <input type="radio"/> | <input type="radio"/> | <input type="radio"/> | <input type="radio"/> |
| PB04 | FFC | Feed forward gain | 0 | [%] | Each | <input type="radio"/> | <input type="radio"/> | <input type="radio"/> | <input type="radio"/> |
| PB05 | | For manufacturer setting | 500 | | | <input type="radio"/> | <input type="radio"/> | <input type="radio"/> | <input type="radio"/> |
| PB06 | GD2 | Load to motor inertia ratio/load to motor mass ratio | 7.00 | [Multiplier] | Each | <input type="radio"/> | <input type="radio"/> | <input type="radio"/> | <input type="radio"/> |
| PB07 | PG1 | Model loop gain | 15.0 | [rad/s] | Each | <input type="radio"/> | <input type="radio"/> | <input type="radio"/> | <input type="radio"/> |
| PB08 | PG2 | Position loop gain | 37.0 | [rad/s] | Each | <input type="radio"/> | <input type="radio"/> | <input type="radio"/> | <input type="radio"/> |
| PB09 | VG2 | Speed loop gain | 823 | [rad/s] | Each | <input type="radio"/> | <input type="radio"/> | <input type="radio"/> | <input type="radio"/> |
| PB10 | VIC | Speed integral compensation | 33.7 | [ms] | Each | <input type="radio"/> | <input type="radio"/> | <input type="radio"/> | <input type="radio"/> |
| PB11 | VDC | Speed differential compensation | 980 | | Each | <input type="radio"/> | <input type="radio"/> | <input type="radio"/> | <input type="radio"/> |
| PB12 | OVA | Overshoot amount compensation | 0 | [%] | Each | <input type="radio"/> | <input type="radio"/> | <input type="radio"/> | <input type="radio"/> |
| PB13 | NH1 | Machine resonance suppression filter 1 | 4500 | [Hz] | Each | <input type="radio"/> | <input type="radio"/> | <input type="radio"/> | <input type="radio"/> |
| PB14 | NHQ1 | Notch shape selection 1 | 0000h | | Each | <input type="radio"/> | <input type="radio"/> | <input type="radio"/> | <input type="radio"/> |
| PB15 | NH2 | Machine resonance suppression filter 2 | 4500 | [Hz] | Each | <input type="radio"/> | <input type="radio"/> | <input type="radio"/> | <input type="radio"/> |
| PB16 | NHQ2 | Notch shape selection 2 | 0000h | | Each | <input type="radio"/> | <input type="radio"/> | <input type="radio"/> | <input type="radio"/> |
| PB17 | NHF | Shaft resonance suppression filter | 0000h | | Each | <input type="radio"/> | <input type="radio"/> | <input type="radio"/> | <input type="radio"/> |
| PB18 | LPF | Low-pass filter setting | 3141 | [rad/s] | Each | <input type="radio"/> | <input type="radio"/> | <input type="radio"/> | <input type="radio"/> |
| PB19 | VRF11 | Vibration suppression control 1 - Vibration frequency | 100.0 | [Hz] | Each | <input type="radio"/> | <input type="radio"/> | <input type="radio"/> | <input type="radio"/> |
| PB20 | VRF12 | Vibration suppression control 1 - Resonance frequency | 100.0 | [Hz] | Each | <input type="radio"/> | <input type="radio"/> | <input type="radio"/> | <input type="radio"/> |
| PB21 | VRF13 | Vibration suppression control 1 - Vibration frequency damping | 0.00 | | Each | <input type="radio"/> | <input type="radio"/> | <input type="radio"/> | <input type="radio"/> |
| PB22 | VRF14 | Vibration suppression control 1 - Resonance frequency damping | 0.00 | | Each | <input type="radio"/> | <input type="radio"/> | <input type="radio"/> | <input type="radio"/> |
| PB23 | VFBF | Low-pass filter selection | 0000h | | Each | <input type="radio"/> | <input type="radio"/> | <input type="radio"/> | <input type="radio"/> |
| PB24 | *MVS | Slight vibration suppression control | 0000h | | Each | <input type="radio"/> | <input type="radio"/> | <input type="radio"/> | <input type="radio"/> |
| PB25 | *BOP1 | Function selection B-1 | 0000h | | Each | <input type="radio"/> | <input type="radio"/> | <input type="radio"/> | <input type="radio"/> |
| PB26 | *CDP | Gain switching function | 0000h | | Each | <input type="radio"/> | <input type="radio"/> | <input type="radio"/> | <input type="radio"/> |
| PB27 | CDL | Gain switching condition | 10 | [kpulse/s]/ [pulse]/ [r/min] | Each | <input type="radio"/> | <input type="radio"/> | <input type="radio"/> | <input type="radio"/> |
| PB28 | CDT | Gain switching time constant | 1 | [ms] | Each | <input type="radio"/> | <input type="radio"/> | <input type="radio"/> | <input type="radio"/> |
| PB29 | GD2B | Load to motor inertia ratio/load to motor mass ratio after gain switching | 7.00 | [Multiplier] | Each | <input type="radio"/> | <input type="radio"/> | <input type="radio"/> | <input type="radio"/> |
| PB30 | PG2B | Position loop gain after gain switching | 0.0 | [rad/s] | Each | <input type="radio"/> | <input type="radio"/> | <input type="radio"/> | <input type="radio"/> |
| PB31 | VG2B | Speed loop gain after gain switching | 0 | [rad/s] | Each | <input type="radio"/> | <input type="radio"/> | <input type="radio"/> | <input type="radio"/> |
| PB32 | VICB | Speed integral compensation after gain switching | 0.0 | [ms] | Each | <input type="radio"/> | <input type="radio"/> | <input type="radio"/> | <input type="radio"/> |
| PB33 | VRF11B | Vibration suppression control 1 - Vibration frequency after gain switching | 0.0 | [Hz] | Each | <input type="radio"/> | <input type="radio"/> | <input type="radio"/> | <input type="radio"/> |
| PB34 | VRF12B | Vibration suppression control 1 - Resonance frequency after gain switching | 0.0 | [Hz] | Each | <input type="radio"/> | <input type="radio"/> | <input type="radio"/> | <input type="radio"/> |
| PB35 | VRF13B | Vibration suppression control 1 - Vibration frequency damping after gain switching | 0.00 | | Each | <input type="radio"/> | <input type="radio"/> | <input type="radio"/> | <input type="radio"/> |
| PB36 | VRF14B | Vibration suppression control 1 - Resonance frequency damping after gain switching | 0.00 | | Each | <input type="radio"/> | <input type="radio"/> | <input type="radio"/> | <input type="radio"/> |
| PB37 | | For manufacturer setting | 1600 | | | <input type="radio"/> | <input type="radio"/> | <input type="radio"/> | <input type="radio"/> |
| PB38 | | | 0.00 | | | <input type="radio"/> | <input type="radio"/> | <input type="radio"/> | <input type="radio"/> |
| PB39 | | | 0.00 | | | <input type="radio"/> | <input type="radio"/> | <input type="radio"/> | <input type="radio"/> |
| PB40 | | | 0.00 | | | <input type="radio"/> | <input type="radio"/> | <input type="radio"/> | <input type="radio"/> |
| PB41 | | | 0 | | | <input type="radio"/> | <input type="radio"/> | <input type="radio"/> | <input type="radio"/> |
| PB42 | | | 0 | | | <input type="radio"/> | <input type="radio"/> | <input type="radio"/> | <input type="radio"/> |

5. PARAMETERS

| No. | Symbol | Name | Initial value | Unit | Each/ Common | Operation mode | | | |
|------|--------|------------------------------------------------------------------------------------|---------------|---------|--------------|-----------------------|-----------------------|-----------------------|-----------------------|
| | | | | | | Standard | Full. | Lin. | D.D. |
| PB43 | | For manufacturer setting | 0000h | | | | | | |
| PB44 | | | 0.00 | | | | | | |
| PB45 | CNHF | Command notch filter | 0000h | | Each | <input type="radio"/> | <input type="radio"/> | <input type="radio"/> | <input type="radio"/> |
| PB46 | NH3 | Machine resonance suppression filter 3 | 4500 | [Hz] | Each | <input type="radio"/> | <input type="radio"/> | <input type="radio"/> | <input type="radio"/> |
| PB47 | NHQ3 | Notch shape selection 3 | 0000h | | Each | <input type="radio"/> | <input type="radio"/> | <input type="radio"/> | <input type="radio"/> |
| PB48 | NH4 | Machine resonance suppression filter 4 | 4500 | [Hz] | Each | <input type="radio"/> | <input type="radio"/> | <input type="radio"/> | <input type="radio"/> |
| PB49 | NHQ4 | Notch shape selection 4 | 0000h | | Each | <input type="radio"/> | <input type="radio"/> | <input type="radio"/> | <input type="radio"/> |
| PB50 | NH5 | Machine resonance suppression filter 5 | 4500 | [Hz] | Each | <input type="radio"/> | <input type="radio"/> | <input type="radio"/> | <input type="radio"/> |
| PB51 | NHQ5 | Notch shape selection 5 | 0000h | | Each | <input type="radio"/> | <input type="radio"/> | <input type="radio"/> | <input type="radio"/> |
| PB52 | VRF21 | Vibration suppression control 2 - Vibration frequency | 100.0 | [Hz] | Each | <input type="radio"/> | <input type="radio"/> | <input type="radio"/> | <input type="radio"/> |
| PB53 | VRF22 | Vibration suppression control 2 - Resonance frequency | 100.0 | [Hz] | Each | <input type="radio"/> | <input type="radio"/> | <input type="radio"/> | <input type="radio"/> |
| PB54 | VRF23 | Vibration suppression control 2 - Vibration frequency damping | 0.00 | | Each | <input type="radio"/> | <input type="radio"/> | <input type="radio"/> | <input type="radio"/> |
| PB55 | VRF24 | Vibration suppression control 2 - Resonance frequency damping | 0.00 | | Each | <input type="radio"/> | <input type="radio"/> | <input type="radio"/> | <input type="radio"/> |
| PB56 | VRF21B | Vibration suppression control 2 - Vibration frequency after gain switching | 0.0 | [Hz] | Each | <input type="radio"/> | <input type="radio"/> | <input type="radio"/> | <input type="radio"/> |
| PB57 | VRF22B | Vibration suppression control 2 - Resonance frequency after gain switching | 0.0 | [Hz] | Each | <input type="radio"/> | <input type="radio"/> | <input type="radio"/> | <input type="radio"/> |
| PB58 | VRF23B | Vibration suppression control 2 - Vibration frequency damping after gain switching | 0.00 | | Each | <input type="radio"/> | <input type="radio"/> | <input type="radio"/> | <input type="radio"/> |
| PB59 | VRF24B | Vibration suppression control 2 - Resonance frequency damping after gain switching | 0.00 | | Each | <input type="radio"/> | <input type="radio"/> | <input type="radio"/> | <input type="radio"/> |
| PB60 | PG1B | Model loop gain after gain switching | 0.0 | [rad/s] | Each | <input type="radio"/> | <input type="radio"/> | <input type="radio"/> | <input type="radio"/> |
| PB61 | | For manufacturer setting | 0.0 | | | | | | |
| PB62 | | | 0000h | | | | | | |
| PB63 | | | 0000h | | | | | | |
| PB64 | | | 0000h | | | | | | |

5.1.3 Extension setting parameters ([Pr. PC_ _])

| No. | Symbol | Name | Initial value | Unit | Each/ Common | Operation mode | | | |
|------|--------|---------------------------------------|---------------|--------------------|--------------|-----------------------|-----------------------|-----------------------|-----------------------|
| | | | | | | Standard | Full. | Lin. | D.D. |
| PC01 | ERZ | Error excessive alarm level | 0 | [rev]/ [mm] | Each | <input type="radio"/> | <input type="radio"/> | <input type="radio"/> | <input type="radio"/> |
| PC02 | MBR | Electromagnetic brake sequence output | 0 | [ms] | Each | <input type="radio"/> | <input type="radio"/> | <input type="radio"/> | <input type="radio"/> |
| PC03 | *ENRS | Encoder output pulse selection | 0000h | | Each | <input type="radio"/> | <input type="radio"/> | <input type="radio"/> | <input type="radio"/> |
| PC04 | **COP1 | Function selection C-1 | 0000h | | Each | <input type="radio"/> | <input type="radio"/> | <input type="radio"/> | <input type="radio"/> |
| PC05 | **COP2 | Function selection C-2 | 0000h | | Each | <input type="radio"/> | <input type="radio"/> | <input type="radio"/> | <input type="radio"/> |
| PC06 | *COP3 | Function selection C-3 | 0000h | | Each | <input type="radio"/> | <input type="radio"/> | <input type="radio"/> | <input type="radio"/> |
| PC07 | ZSP | Zero speed | 50 | [r/min]/ [mm/s] | Each | <input type="radio"/> | <input type="radio"/> | <input type="radio"/> | <input type="radio"/> |
| PC08 | OSL | Overspeed alarm detection level | 0 | [r/min]/ [mm/s] | Each | <input type="radio"/> | <input type="radio"/> | <input type="radio"/> | <input type="radio"/> |

5. PARAMETERS

| No. | Symbol | Name | Initial value | Unit | Each/ Common | Operation mode | | | |
|------|--------|----------------------------------------------------------------|---------------|---------------------------|-----------------|-----------------------|-----------------------|-----------------------|-----------------------|
| | | | | | | Standard | Full. | Lin. | D.D. |
| PC09 | MOD1 | Analog monitor 1 output | 0000h | | Common | <input type="radio"/> | | | |
| PC10 | MOD2 | Analog monitor 2 output | 0001h | | Common | <input type="radio"/> | | | |
| PC11 | MO1 | Analog monitor 1 offset | 0 | [mV] | Common | <input type="radio"/> | | | |
| PC12 | MO2 | Analog monitor 2 offset | 0 | [mV] | Common | <input type="radio"/> | | | |
| PC13 | MOSDL | Analog monitor - Feedback position output standard data - Low | 0 | [pulse] | Each | <input type="radio"/> | | | |
| PC14 | MOSDH | Analog monitor - Feedback position output standard data - High | 0 | [10000 pulses] | Each | <input type="radio"/> | | | |
| PC15 | | For manufacturer setting | 0 | | | | | | |
| PC16 | | | 0000h | | | | | | |
| PC17 | **COP4 | Function selection C-4 | 0000h | | Each | <input type="radio"/> | <input type="radio"/> | <input type="radio"/> | <input type="radio"/> |
| PC18 | *COP5 | Function selection C-5 | 0000h | | Common | <input type="radio"/> | <input type="radio"/> | <input type="radio"/> | <input type="radio"/> |
| PC19 | | For manufacturer setting | 0000h | | | | | | |
| PC20 | *COP7 | Function selection C-7 | 0000h | | Common | <input type="radio"/> | <input type="radio"/> | <input type="radio"/> | <input type="radio"/> |
| PC21 | *BPS | Alarm history clear | 0000h | | Each | <input type="radio"/> | <input type="radio"/> | <input type="radio"/> | <input type="radio"/> |
| PC22 | | For manufacturer setting | 0 | | | | | | |
| PC23 | | | 0000h | | | | | | |
| PC24 | RSBR | Forced stop deceleration time constant | 100 | [ms] | Each | <input type="radio"/> | <input type="radio"/> | <input type="radio"/> | <input type="radio"/> |
| PC25 | | For manufacturer setting | 0 | | | | | | |
| PC26 | | | 0000h | | | | | | |
| PC27 | **COP9 | Function selection C-9 | 0000h | | Each | <input type="radio"/> | <input type="radio"/> | <input type="radio"/> | <input type="radio"/> |
| PC28 | | For manufacturer setting | 0000h | | | | | | |
| PC29 | *COPB | Function selection C-B | 0000h | | Each | <input type="radio"/> | | <input type="radio"/> | <input type="radio"/> |
| PC30 | | For manufacturer setting | 0 | | | | | | |
| PC31 | RSUP1 | Vertical axis freefall prevention compensation amount | 0 | [0.0001 rev/ [0.01 mm] | Each | <input type="radio"/> | <input type="radio"/> | <input type="radio"/> | <input type="radio"/> |
| PC32 | | For manufacturer setting | 0000h | | | | | | |
| PC33 | | | 0 | | | | | | |
| PC34 | | | 100 | | | | | | |
| PC35 | | | 0000h | | | | | | |
| PC36 | | | 0000h | | | | | | |
| PC37 | | | 0000h | | | | | | |
| PC38 | ERW | Error excessive warning level | 0 | [rev]/[mm] | Each | <input type="radio"/> | <input type="radio"/> | <input type="radio"/> | <input type="radio"/> |
| PC39 | | For manufacturer setting | 0000h | | | | | | |
| PC40 | | | 0000h | | | | | | |
| PC41 | | | 0000h | | | | | | |
| PC42 | | | 0000h | | | | | | |
| PC43 | | | 0000h | | | | | | |
| PC44 | | | 0000h | | | | | | |
| PC45 | | | 0000h | | | | | | |
| PC46 | | | 0000h | | | | | | |
| PC47 | | | 0000h | | | | | | |
| PC48 | | | 0000h | | | | | | |
| PC49 | | | 0000h | | | | | | |
| PC50 | | | 0000h | | | | | | |
| PC51 | | | 0000h | | | | | | |
| PC52 | | | 0000h | | | | | | |
| PC53 | | | 0000h | | | | | | |
| PC54 | | | 0000h | | | | | | |
| PC55 | | | 0000h | | | | | | |

Note. It is available when the scale measurement function is enabled ([Pr. PA22] is "1 ___" or "2 ___").

5. PARAMETERS

| No. | Symbol | Name | Initial value | Unit | Each/ Common | Operation mode | | | |
|------|--------|--------------------------|---------------|------|-----------------|----------------|-------|------|------|
| | | | | | | Standard | Full. | Lin. | D.D. |
| PC56 | | For manufacturer setting | 0000h | | | | | | |
| PC57 | | | 0000h | | | | | | |
| PC58 | | | 0000h | | | | | | |
| PC59 | | | 0000h | | | | | | |
| PC60 | | | 0000h | | | | | | |
| PC61 | | | 0000h | | | | | | |
| PC62 | | | 0000h | | | | | | |
| PC63 | | | 0000h | | | | | | |
| PC64 | | | 0000h | | | | | | |

5.1.4 I/O setting parameters ([Pr. PD_ _])

| No. | Symbol | Name | Initial value | Unit | Each/ Common | Operation mode | | | |
|------|--------|---------------------------------------|---------------|------|-----------------|----------------|-------|------|------|
| | | | | | | Standard | Full. | Lin. | D.D. |
| PD01 | *DIA2 | For manufacturer setting | 0000h | | Each | | | | |
| PD02 | | Input signal automatic on selection 2 | 0000h | | | | | | |
| PD03 | | For manufacturer setting | 0020h | | | | | | |
| PD04 | | | 0021h | | | | | | |
| PD05 | | | 0022h | | | | | | |
| PD06 | | | 0000h | | | | | | |
| PD07 | *DO1 | Output device selection 1 | 0005h | | Each | | | | |
| PD08 | *DO2 | Output device selection 2 | 0004h | | Common | | | | |
| PD09 | *DO3 | Output device selection 3 | 0003h | | Common | | | | |
| PD10 | *DIF | For manufacturer setting | 0000h | | | | | | |
| PD11 | | Input filter setting (Note) | 0004h | | | | | | |
| PD12 | *DOP1 | Function selection D-1 | 0000h | | Each | | | | |
| PD13 | *DOP3 | For manufacturer setting | 0000h | | | | | | |
| PD14 | | Function selection D-3 | 0000h | | | | | | |
| PD15 | | For manufacturer setting | 0000h | | | | | | |
| PD16 | | | 0000h | | | | | | |
| PD17 | | | 0000h | | | | | | |
| PD18 | | | 0000h | | | | | | |
| PD19 | | | 0000h | | | | | | |
| PD20 | | | 0 | | | | | | |
| PD21 | | | 0 | | | | | | |
| PD22 | | | 0 | | | | | | |
| PD23 | | | 0 | | | | | | |
| PD24 | | | 0000h | | | | | | |
| PD25 | | | 0000h | | | | | | |
| PD26 | | | 0000h | | | | | | |
| PD27 | | | 0000h | | | | | | |
| PD28 | | | 0000h | | | | | | |
| PD29 | | | 0000h | | | | | | |
| PD30 | 0 | | | | | | | | |

5. PARAMETERS

| No. | Symbol | Name | Initial value | Unit | Each/ Common | Operation mode | | | |
|------|--------|--------------------------|---------------|------|--------------|----------------|-------|------|------|
| | | | | | | Standard | Full. | Lin. | D.D. |
| PD31 | | For manufacturer setting | 0 | | | | | | |
| PD32 | | | 0 | | | | | | |
| PD33 | | | 0000h | | | | | | |
| PD34 | | | 0000h | | | | | | |
| PD35 | | | 0000h | | | | | | |
| PD36 | | | 0000h | | | | | | |
| PD37 | | | 0000h | | | | | | |
| PD38 | | | 0000h | | | | | | |
| PD39 | | | 0000h | | | | | | |
| PD40 | | | 0000h | | | | | | |
| PD41 | | | 0000h | | | | | | |
| PD42 | | | 0000h | | | | | | |
| PD43 | | | 0000h | | | | | | |
| PD44 | | | 0000h | | | | | | |
| PD45 | | | 0000h | | | | | | |
| PD46 | | | 0000h | | | | | | |
| PD47 | | | 0000h | | | | | | |
| PD48 | | | 0000h | | | | | | |

Note. Refer to the servo system controller instruction manual for the setting.

5.1.5 Extension setting 2 parameters ([Pr. PE_ _])

| No. | Symbol | Name | Initial value | Unit | Each/ Common | Operation mode | | | |
|------|--------|----------------------------------------------------------------------------|---------------|----------|--------------|-----------------------|-----------------------|------|------|
| | | | | | | Standard | Full. | Lin. | D.D. |
| PE01 | **FCT1 | Fully closed loop function selection 1 | 0000h | | Each | | <input type="radio"/> | | |
| PE02 | | For manufacturer setting | 0000h | | | | | | |
| PE03 | *FCT2 | Fully closed loop function selection 2 | 0003h | | Each | | <input type="radio"/> | | |
| PE04 | **FBN | Fully closed loop control - Feedback pulse electronic gear 1 - Numerator | 1 | | Each | | <input type="radio"/> | | |
| PE05 | **FBD | Fully closed loop control - Feedback pulse electronic gear 1 - Denominator | 1 | | Each | | <input type="radio"/> | | |
| PE06 | BC1 | Fully closed loop control - Speed deviation error detection level | 400 | [r/min] | Each | | <input type="radio"/> | | |
| PE07 | BC2 | Fully closed loop control - Position deviation error detection level | 100 | [kpulse] | Each | | <input type="radio"/> | | |
| PE08 | DUF | Fully closed loop dual feedback filter | 10 | [rad/s] | Each | | <input type="radio"/> | | |
| PE09 | | For manufacturer setting | 0000h | | | | | | |
| PE10 | FCT3 | Fully closed loop function selection 3 | 0000h | | Each | <input type="radio"/> | <input type="radio"/> | | |
| PE11 | | For manufacturer setting | 0000h | | | | | | |
| PE12 | | | 0000h | | | | | | |
| PE13 | | | 0000h | | | | | | |
| PE14 | | | 0111h | | | | | | |
| PE15 | | | 20 | | | | | | |
| PE16 | | | 0000h | | | | | | |
| PE17 | | | 0000h | | | | | | |
| PE18 | | | 0000h | | | | | | |
| PE19 | | | 0000h | | | | | | |
| PE20 | | | 0000h | | | | | | |
| PE21 | | | 0000h | | | | | | |

5. PARAMETERS

| No. | Symbol | Name | Initial value | Unit | Each/ Common | Operation mode | | | |
|------|--------|----------------------------------------------------------------------------|---------------|---------|-----------------|----------------|-------|------|------|
| | | | | | | Standard | Full. | Lin. | D.D. |
| PE22 | | For manufacturer setting | 0000h | | | | | | |
| PE23 | | | 0000h | | | | | | |
| PE24 | | | 0000h | | | | | | |
| PE25 | | | 0000h | | | | | | |
| PE26 | | | 0000h | | | | | | |
| PE27 | | | 0000h | | | | | | |
| PE28 | | | 0000h | | | | | | |
| PE29 | | | 0000h | | | | | | |
| PE30 | | | 0000h | | | | | | |
| PE31 | | | 0000h | | | | | | |
| PE32 | | | 0000h | | | | | | |
| PE33 | | | 0000h | | | | | | |
| PE34 | | | **FBN2 | | | | | | |
| PE35 | **FBD2 | Fully closed loop control - Feedback pulse electronic gear 2 - Denominator | 1 | | Each | | ○ | | |
| PE36 | | For manufacturer setting | 0.0 | | | | | | |
| PE37 | | | 0.00 | | | | | | |
| PE38 | | | 0.00 | | | | | | |
| PE39 | | | 20 | | | | | | |
| PE40 | | | 0000h | | | | | | |
| PE41 | EOP3 | Function selection E-3 | 0000h | | Each | ○ | ○ | ○ | ○ |
| PE42 | | For manufacturer setting | 0 | | | | | | |
| PE43 | | | 0.0 | | | | | | |
| PE44 | | | 0 | | | | | | |
| PE45 | | | 0 | | | | | | |
| PE46 | | | 0 | | | | | | |
| PE47 | TOF | Torque offset | 0 | [0.01%] | Each | ○ | ○ | | |
| PE48 | | For manufacturer setting | 0000h | | | | | | |
| PE49 | | | 0 | | | | | | |
| PE50 | | | 0 | | | | | | |
| PE51 | | | 0000h | | | | | | |
| PE52 | | | 0000h | | | | | | |
| PE53 | | | 0000h | | | | | | |
| PE54 | | | 0000h | | | | | | |
| PE55 | | | 0000h | | | | | | |
| PE56 | | | 0000h | | | | | | |
| PE57 | | | 0000h | | | | | | |
| PE58 | | | 0000h | | | | | | |
| PE59 | | | 0000h | | | | | | |
| PE60 | | | 0000h | | | | | | |
| PE61 | | | 0.00 | | | | | | |
| PE62 | | | 0.00 | | | | | | |
| PE63 | | | 0.00 | | | | | | |
| PE64 | | | 0.00 | | | | | | |

5. PARAMETERS

5.1.6 Extension setting 3 parameters ([Pr. PF__])

| No. | Symbol | Name | Initial value | Unit | Each/ Common | Operation mode | | | |
|------|--------|----------------------------------------------------------------|---------------|--------------------|-----------------|-----------------------|-----------------------|-----------------------|-----------------------|
| | | | | | | Standard | Full. | Lin. | D.D. |
| PF01 | | For manufacturer setting | 0000h | | | | | | |
| PF02 | *FOP2 | Function selection F-2 | 0000h | | Common | <input type="radio"/> | <input type="radio"/> | <input type="radio"/> | <input type="radio"/> |
| PF03 | | For manufacturer setting | 0000h | | | | | | |
| PF04 | | | 0 | | | | | | |
| PF05 | | | 0000h | | | | | | |
| PF06 | *FOP5 | Function selection F-5 | 0000h | | Each | <input type="radio"/> | <input type="radio"/> | | |
| PF07 | | For manufacturer setting | 0000h | | | | | | |
| PF08 | | | 0000h | | | | | | |
| PF09 | | | 0 | | | | | | |
| PF10 | | | 0 | | | | | | |
| PF11 | | | 0 | | | | | | |
| PF12 | DBT | Electronic dynamic brake operating time | 2000 | [ms] | Each | <input type="radio"/> | <input type="radio"/> | | |
| PF13 | | For manufacturer setting | 0000h | | | | | | |
| PF14 | | | 10 | | | | | | |
| PF15 | | | 0000h | | | | | | |
| PF16 | | | 0000h | | | | | | |
| PF17 | | | 0000h | | | | | | |
| PF18 | **STOD | STO diagnosis error detection time | 0 | [s] | Common | <input type="radio"/> | <input type="radio"/> | <input type="radio"/> | <input type="radio"/> |
| PF19 | | | 0000h | | | | | | |
| PF20 | | | 0000h | | | | | | |
| PF21 | DRT | Drive recorder switching time setting | 0 | [s] | Common | <input type="radio"/> | <input type="radio"/> | <input type="radio"/> | <input type="radio"/> |
| PF22 | | For manufacturer setting | 200 | | | | | | |
| PF23 | OSCL1 | Vibration tough drive - Oscillation detection level | 50 | [%] | Each | <input type="radio"/> | <input type="radio"/> | <input type="radio"/> | <input type="radio"/> |
| PF24 | *OSCL2 | Vibration tough drive function selection | 0000h | | Each | <input type="radio"/> | <input type="radio"/> | <input type="radio"/> | <input type="radio"/> |
| PF25 | CVAT | SEMI-F47 function - Instantaneous power failure detection time | 200 | [ms] | Common | <input type="radio"/> | <input type="radio"/> | <input type="radio"/> | <input type="radio"/> |
| PF26 | | For manufacturer setting | 0 | | | | | | |
| PF27 | | | 0 | | | | | | |
| PF28 | | | 0 | | | | | | |
| PF29 | | | 0000h | | | | | | |
| PF30 | | | 0 | | | | | | |
| PF31 | FRIC | Machine diagnosis function - Friction judgment speed | 0 | [r/min]/ [mm/s] | Each | <input type="radio"/> | <input type="radio"/> | <input type="radio"/> | <input type="radio"/> |
| PF32 | | For manufacturer setting | 50 | | | | | | |
| PF33 | | | 0000h | | | | | | |
| PF34 | | | 0000h | | | | | | |
| PF35 | | | 0000h | | | | | | |
| PF36 | | | 0000h | | | | | | |
| PF37 | | | 0000h | | | | | | |
| PF38 | | | 0000h | | | | | | |
| PF39 | | | 0000h | | | | | | |
| PF40 | | | 0000h | | | | | | |
| PF41 | | | 0000h | | | | | | |
| PF42 | | | 0000h | | | | | | |
| PF43 | | | 0000h | | | | | | |
| PF44 | | | 0 | | | | | | |
| PF45 | | | 0000h | | | | | | |
| PF46 | | | 0000h | | | | | | |
| PF47 | | | 0000h | | | | | | |
| PF48 | | | 0000h | | | | | | |

5. PARAMETERS

5.1.7 Linear servo motor/DD motor setting parameters ([Pr. PL_ _])

| No. | Symbol | Name | Initial value | Unit | Each/ Common | Operation mode | | | |
|------|--------|----------------------------------------------------------------------------------------------|---------------|---------------------|--------------|----------------|-------|-----------------------|-----------------------|
| | | | | | | Standard | Full. | Lin. | D.D. |
| PL01 | **LIT1 | Linear servo motor/DD motor function selection 1 | 0301h | | Each | | | <input type="radio"/> | <input type="radio"/> |
| PL02 | **LIM | Linear encoder resolution - Numerator | 1000 | [μm] | Each | | | <input type="radio"/> | <input type="radio"/> |
| PL03 | **LID | Linear encoder resolution - Denominator | 1000 | [μm] | Each | | | <input type="radio"/> | <input type="radio"/> |
| PL04 | *LIT2 | Linear servo motor/DD motor function selection 2 | 0003h | | Each | | | <input type="radio"/> | <input type="radio"/> |
| PL05 | LB1 | Position deviation error detection level | 0 | [mm]/ [0.01 rev] | Each | | | <input type="radio"/> | <input type="radio"/> |
| PL06 | LB2 | Speed deviation error detection level | 0 | [r/min]/ [mm/s] | Each | | | <input type="radio"/> | <input type="radio"/> |
| PL07 | LB3 | Torque/thrust deviation error detection level | 100 | [%] | Each | | | <input type="radio"/> | <input type="radio"/> |
| PL08 | *LIT3 | Linear servo motor/DD motor function selection 3 | 0010h | | Each | | | <input type="radio"/> | <input type="radio"/> |
| PL09 | LPWM | Magnetic pole detection voltage level | 30 | [%] | Each | | | <input type="radio"/> | <input type="radio"/> |
| PL10 | | For manufacturer setting | 5 | | | | | | |
| PL11 | | | 100 | | | | | | |
| PL12 | | | 500 | | | | | | |
| PL13 | | | 0000h | | | | | | |
| PL14 | | | 0 | | | | | | |
| PL15 | | | 20 | | | | | | |
| PL16 | | | 0 | | | | | | |
| PL17 | LTSTS | Magnetic pole detection - Minute position detection method - Function selection | 0000h | | Each | | | <input type="radio"/> | <input type="radio"/> |
| PL18 | IDLV | Magnetic pole detection - Minute position detection method - Identification signal amplitude | 0 | [%] | Each | | | <input type="radio"/> | <input type="radio"/> |
| PL19 | | For manufacturer setting | 0 | | | | | | |
| PL20 | | | 0 | | | | | | |
| PL21 | | | 0 | | | | | | |
| PL22 | | | 0 | | | | | | |
| PL23 | | | 0000h | | | | | | |
| PL24 | | | 0 | | | | | | |
| PL25 | | | 0000h | | | | | | |
| PL26 | | | 0000h | | | | | | |
| PL27 | | | 0000h | | | | | | |
| PL28 | | | 0000h | | | | | | |
| PL29 | | | 0000h | | | | | | |
| PL30 | | | 0000h | | | | | | |
| PL31 | | | 0000h | | | | | | |
| PL32 | | | 0000h | | | | | | |
| PL33 | | | 0000h | | | | | | |
| PL34 | | | 0000h | | | | | | |
| PL35 | | | 0000h | | | | | | |

5. PARAMETERS

| No. | Symbol | Name | Initial value | Unit | Each/ Common | Operation mode | | | |
|------|--------|--------------------------|---------------|------|-----------------|----------------|-------|------|------|
| | | | | | | Standard | Full. | Lin. | D.D. |
| PL36 | | For manufacturer setting | 0000h | | | | | | |
| PL37 | | | 0000h | | | | | | |
| PL38 | | | 0000h | | | | | | |
| PL39 | | | 0000h | | | | | | |
| PL40 | | | 0000h | | | | | | |
| PL41 | | | 0000h | | | | | | |
| PL42 | | | 0000h | | | | | | |
| PL43 | | | 0000h | | | | | | |
| PL44 | | | 0000h | | | | | | |
| PL45 | | | 0000h | | | | | | |
| PL46 | | | 0000h | | | | | | |
| PL47 | | | 0000h | | | | | | |
| PL48 | | | 0000h | | | | | | |

5. PARAMETERS

5.2 Detailed list of parameters

| |
|------------------------------------------------------------------------|
| POINT |
| ● "x" in the "Setting digit" columns means which digit to set a value. |

5.2.1 Basic setting parameters ([Pr. PA_ _])

| No. | Symbol | Name and function | Initial value [unit] | Setting range | Each/ Common | | | | | | | | | | | | | | | |
|---------------|---------------------------------------------------------------------------------------------------------------------------------------------------------------------------------------------------------------------------------------------------------------------------------------------------------------------------------------------------------------------------------------------------------------------------------------------------------------------------------------------------------------------|----------------------------------------------------------------------------------------------------------------------------------------------------------------------------------------------------------------------------------------------------------------------------------------------------------------------------------------------------------------------------------------------------------------------------------------------------------------------------------------------------------------------------------------------------------------------------------------------------------------------------------------------------------------------------------------------------------------------------------------------------------------------------------------------------------------------------------------------------------------------------------------------------------------------------------------------------------------------------------------------------------------------------------------------------------------------------------------------------------------------------------------------------------------------------------------------------------------------------------------------------------------------|----------------------|---------------|---------------|--------|--------------------------------------------------------------------------------------------------------------------------------------------------------------------------------------------------------------------------------------------------------------|-----|---------|---------------------------------------------------------------------------------------------------------------------------------------------------------------------------------------------------------------------------------------------------------------------------------------------------------------------------------------------------------------------------------------------------------------------------------------------------------------------------------------------------------------------|----|---------|--------------------------|----|------------------------------------|------------------------------------------------------------------------------------------------------------------------------------------------------------------------------------------------------------------------------------------------------------------------------------|--------|------------------------------------|--|------|
| PA01 | **STY | <p>Operation mode Select an operation mode.</p> <table border="1"> <thead> <tr> <th>Setting digit</th> <th>Explanation</th> <th>Initial value</th> </tr> </thead> <tbody> <tr> <td>__ _ x</td> <td>For manufacturer setting</td> <td>0h</td> </tr> <tr> <td>__ x _</td> <td>Operation mode selection 0: Standard control mode 1: Fully closed loop control mode 4. Linear servo motor control mode 6: DD motor control mode Setting other than above will result in [AL. 37 Parameter error]. The fully closed loop system is available for the MR-J4W2-_B servo amplifiers of which software version is A3 or later. It will not be available with MR-J4W3-_B servo amplifiers. For MR-J4W2-0303B6 servo amplifiers, this digit cannot be used other than the initial value.</td> <td>0h</td> </tr> <tr> <td>_ x _ _</td> <td>For manufacturer setting</td> <td>0h</td> </tr> <tr> <td>x _ _ _</td> <td>Compatibility mode selection To change this digit, use an application software "MR-J4(W)-B mode selection". When you change it without the application, [AL. 3E Operation mode error] will occur. Set the digit as common setting. 0: J3 compatibility mode 1: J4 mode</td> <td>1h</td> </tr> </tbody> </table> | Setting digit | Explanation | Initial value | __ _ x | For manufacturer setting | 0h | __ x _ | Operation mode selection 0: Standard control mode 1: Fully closed loop control mode 4. Linear servo motor control mode 6: DD motor control mode Setting other than above will result in [AL. 37 Parameter error]. The fully closed loop system is available for the MR-J4W2-_B servo amplifiers of which software version is A3 or later. It will not be available with MR-J4W3-_B servo amplifiers. For MR-J4W2-0303B6 servo amplifiers, this digit cannot be used other than the initial value. | 0h | _ x _ _ | For manufacturer setting | 0h | x _ _ _ | Compatibility mode selection To change this digit, use an application software "MR-J4(W)-B mode selection". When you change it without the application, [AL. 3E Operation mode error] will occur. Set the digit as common setting. 0: J3 compatibility mode 1: J4 mode | 1h | Refer to Name and function column. | | Each |
| Setting digit | Explanation | Initial value | | | | | | | | | | | | | | | | | | |
| __ _ x | For manufacturer setting | 0h | | | | | | | | | | | | | | | | | | |
| __ x _ | Operation mode selection 0: Standard control mode 1: Fully closed loop control mode 4. Linear servo motor control mode 6: DD motor control mode Setting other than above will result in [AL. 37 Parameter error]. The fully closed loop system is available for the MR-J4W2-_B servo amplifiers of which software version is A3 or later. It will not be available with MR-J4W3-_B servo amplifiers. For MR-J4W2-0303B6 servo amplifiers, this digit cannot be used other than the initial value. | 0h | | | | | | | | | | | | | | | | | | |
| _ x _ _ | For manufacturer setting | 0h | | | | | | | | | | | | | | | | | | |
| x _ _ _ | Compatibility mode selection To change this digit, use an application software "MR-J4(W)-B mode selection". When you change it without the application, [AL. 3E Operation mode error] will occur. Set the digit as common setting. 0: J3 compatibility mode 1: J4 mode | 1h | | | | | | | | | | | | | | | | | | |
| PA02 | **REG | <p>Regenerative option Select a regenerative option. Incorrect setting may cause the regenerative option to burn. If a selected regenerative option is not for use with the servo amplifier, [AL. 37 Parameter error] occurs.</p> <table border="1"> <thead> <tr> <th>Setting digit</th> <th>Explanation</th> <th>Initial value</th> </tr> </thead> <tbody> <tr> <td>__ x x</td> <td>Regenerative option selection 00: Regenerative option is not used. (Built-in regenerative resistor is used.) 0B: MR-RB3N 0D: MR-RB14 0E: MR-RB34 For MR-J4W2-0303B6 servo amplifiers, this digit cannot be used other than the initial value.</td> <td>00h</td> </tr> <tr> <td>_ x _ _</td> <td>For manufacturer setting</td> <td>0h</td> </tr> <tr> <td>x _ _ _</td> <td></td> <td>0h</td> </tr> </tbody> </table> | Setting digit | Explanation | Initial value | __ x x | Regenerative option selection 00: Regenerative option is not used. (Built-in regenerative resistor is used.) 0B: MR-RB3N 0D: MR-RB14 0E: MR-RB34 For MR-J4W2-0303B6 servo amplifiers, this digit cannot be used other than the initial value. | 00h | _ x _ _ | For manufacturer setting | 0h | x _ _ _ | | 0h | Refer to Name and function column. | | Common | | | |
| Setting digit | Explanation | Initial value | | | | | | | | | | | | | | | | | | |
| __ x x | Regenerative option selection 00: Regenerative option is not used. (Built-in regenerative resistor is used.) 0B: MR-RB3N 0D: MR-RB14 0E: MR-RB34 For MR-J4W2-0303B6 servo amplifiers, this digit cannot be used other than the initial value. | 00h | | | | | | | | | | | | | | | | | | |
| _ x _ _ | For manufacturer setting | 0h | | | | | | | | | | | | | | | | | | |
| x _ _ _ | | 0h | | | | | | | | | | | | | | | | | | |

5. PARAMETERS

| No. | Symbol | Name and function | Initial value [unit] | Setting range | Each/ Common | | | | | | | | | | | | | | | | | | | | | | | | | | | | | | | | | | | |
|---------------|---------------------------------------------------------------------------------------------------------------------------------------------------------------------------------------------|------------------------------------------------------------------------------------------------------------------------------------------------------------------------------------------------------------------------------------------------------------------------------------------------------------------------------------------------------------------------------------------------------------------------------------------------------------------------------------------------------------------------------------------------------------------------------------------------------------------------------------------------------------------------------------------------------------------------------------------------------------------------------------------------------------------------------------------------------------------------------------------------------------------------------------------------------------------------------------------------------------------------------------------------------------------------------------------------------------------------------------------------------------------------------------------------------------------------------------------------------------------------------------------------------------------------------------------------------------------------------------------------------------------------------------------------------------------------------------------------------------------------------------------------------------------------------------------------------------------------------------------------------------------------------------------------------------------------------------------------------------------------------------------------------------------------------------------------------------------------------------------------------------------------------------------------------------------------------------------------------------------------|---------------------------------------------------------------------------------------|---------------|---------------|------|-----------------------------------------------------------------------------------------------------------------------------------------------------|----|------|--------------------------|------|-------------------------------------------------------------------------------------------------------------------------------------------------------------------------------------------|----|------|---------------------------------------------------------------------------------------------------------------------------------------------------------------------------------------------|------------------------------------|---------------|---------|---------------------|--|-------------------|----------------|------|-----|---------------------------------------------------------------------------------------|---------------------------------------------------------------------------------------|------|-----|-------------------------------------------------------------------------------------|-------------------------------------------------------------------------------------|------|-----------------------|---|---------------------------------------------------------------------------------------|------|-----------------------|-------------------------------------------------------------------------------------|------------------------------------|--|--------|
| PA03 | *ABS | <p>Absolute position detection system</p> <p>Set this parameter when using the absolute position detection system. The parameter is not available in the speed control mode and torque control mode.</p> <table border="1"> <thead> <tr> <th>Setting digit</th> <th>Explanation</th> <th>Initial value</th> </tr> </thead> <tbody> <tr> <td>___x</td> <td>Absolute position detection system selection 0: Disabled (used in incremental system) 1: Enabled (used in absolute position detection system)</td> <td>0h</td> </tr> <tr> <td>__x_</td> <td rowspan="3">For manufacturer setting</td> <td>0h</td> </tr> <tr> <td>_x__</td> <td>0h</td> </tr> <tr> <td>x___</td> <td>0h</td> </tr> </tbody> </table> | Setting digit | Explanation | Initial value | ___x | Absolute position detection system selection 0: Disabled (used in incremental system) 1: Enabled (used in absolute position detection system) | 0h | __x_ | For manufacturer setting | 0h | _x__ | 0h | x___ | 0h | Refer to Name and function column. | | Each | | | | | | | | | | | | | | | | | | | | | | |
| Setting digit | Explanation | Initial value | | | | | | | | | | | | | | | | | | | | | | | | | | | | | | | | | | | | | | |
| ___x | Absolute position detection system selection 0: Disabled (used in incremental system) 1: Enabled (used in absolute position detection system) | 0h | | | | | | | | | | | | | | | | | | | | | | | | | | | | | | | | | | | | | | |
| __x_ | For manufacturer setting | 0h | | | | | | | | | | | | | | | | | | | | | | | | | | | | | | | | | | | | | | |
| _x__ | | 0h | | | | | | | | | | | | | | | | | | | | | | | | | | | | | | | | | | | | | | |
| x___ | | 0h | | | | | | | | | | | | | | | | | | | | | | | | | | | | | | | | | | | | | | |
| PA04 | *AOP1 | <p>Function selection A-1</p> <p>Select a forced stop input and forced stop deceleration function.</p> <table border="1"> <thead> <tr> <th>Setting digit</th> <th>Explanation</th> <th>Initial value</th> </tr> </thead> <tbody> <tr> <td>___x</td> <td rowspan="2">For manufacturer setting</td> <td>0h</td> </tr> <tr> <td>__x_</td> <td>0h</td> </tr> <tr> <td>_x__</td> <td>Servo forced stop selection 0: Enabled (The forced stop input EM2 or EM1 is used.) 1: Disabled (The forced stop input EM2 and EM1 are not used.) Refer to table 5.1 for details.</td> <td>0h</td> </tr> <tr> <td>x___</td> <td>Forced stop deceleration function selection 0: Forced stop deceleration function disabled (EM1) 2: Forced stop deceleration function enabled (EM2) Refer to table 5.1 for details.</td> <td>2h</td> </tr> </tbody> </table> <p style="text-align: center;">Table 5.1 Deceleration method</p> <table border="1"> <thead> <tr> <th rowspan="2">Setting value</th> <th rowspan="2">EM2/EM1</th> <th colspan="2">Deceleration method</th> </tr> <tr> <th>EM2 or EM1 is off</th> <th>Alarm occurred</th> </tr> </thead> <tbody> <tr> <td>00__</td> <td>EM1</td> <td>MBR (Electromagnetic brake interlock) turns off without the forced stop deceleration.</td> <td>MBR (Electromagnetic brake interlock) turns off without the forced stop deceleration.</td> </tr> <tr> <td>20__</td> <td>EM2</td> <td>MBR (Electromagnetic brake interlock) turns off after the forced stop deceleration.</td> <td>MBR (Electromagnetic brake interlock) turns off after the forced stop deceleration.</td> </tr> <tr> <td>01__</td> <td>Not using EM2 and EM1</td> <td rowspan="2" style="text-align: center;">/</td> <td>MBR (Electromagnetic brake interlock) turns off without the forced stop deceleration.</td> </tr> <tr> <td>21__</td> <td>Not using EM2 and EM1</td> <td>MBR (Electromagnetic brake interlock) turns off after the forced stop deceleration.</td> </tr> </tbody> </table> | Setting digit | Explanation | Initial value | ___x | For manufacturer setting | 0h | __x_ | 0h | _x__ | Servo forced stop selection 0: Enabled (The forced stop input EM2 or EM1 is used.) 1: Disabled (The forced stop input EM2 and EM1 are not used.) Refer to table 5.1 for details. | 0h | x___ | Forced stop deceleration function selection 0: Forced stop deceleration function disabled (EM1) 2: Forced stop deceleration function enabled (EM2) Refer to table 5.1 for details. | 2h | Setting value | EM2/EM1 | Deceleration method | | EM2 or EM1 is off | Alarm occurred | 00__ | EM1 | MBR (Electromagnetic brake interlock) turns off without the forced stop deceleration. | MBR (Electromagnetic brake interlock) turns off without the forced stop deceleration. | 20__ | EM2 | MBR (Electromagnetic brake interlock) turns off after the forced stop deceleration. | MBR (Electromagnetic brake interlock) turns off after the forced stop deceleration. | 01__ | Not using EM2 and EM1 | / | MBR (Electromagnetic brake interlock) turns off without the forced stop deceleration. | 21__ | Not using EM2 and EM1 | MBR (Electromagnetic brake interlock) turns off after the forced stop deceleration. | Refer to Name and function column. | | Common |
| Setting digit | Explanation | Initial value | | | | | | | | | | | | | | | | | | | | | | | | | | | | | | | | | | | | | | |
| ___x | For manufacturer setting | 0h | | | | | | | | | | | | | | | | | | | | | | | | | | | | | | | | | | | | | | |
| __x_ | | 0h | | | | | | | | | | | | | | | | | | | | | | | | | | | | | | | | | | | | | | |
| _x__ | Servo forced stop selection 0: Enabled (The forced stop input EM2 or EM1 is used.) 1: Disabled (The forced stop input EM2 and EM1 are not used.) Refer to table 5.1 for details. | 0h | | | | | | | | | | | | | | | | | | | | | | | | | | | | | | | | | | | | | | |
| x___ | Forced stop deceleration function selection 0: Forced stop deceleration function disabled (EM1) 2: Forced stop deceleration function enabled (EM2) Refer to table 5.1 for details. | 2h | | | | | | | | | | | | | | | | | | | | | | | | | | | | | | | | | | | | | | |
| Setting value | EM2/EM1 | Deceleration method | | | | | | | | | | | | | | | | | | | | | | | | | | | | | | | | | | | | | | |
| | | EM2 or EM1 is off | Alarm occurred | | | | | | | | | | | | | | | | | | | | | | | | | | | | | | | | | | | | | |
| 00__ | EM1 | MBR (Electromagnetic brake interlock) turns off without the forced stop deceleration. | MBR (Electromagnetic brake interlock) turns off without the forced stop deceleration. | | | | | | | | | | | | | | | | | | | | | | | | | | | | | | | | | | | | | |
| 20__ | EM2 | MBR (Electromagnetic brake interlock) turns off after the forced stop deceleration. | MBR (Electromagnetic brake interlock) turns off after the forced stop deceleration. | | | | | | | | | | | | | | | | | | | | | | | | | | | | | | | | | | | | | |
| 01__ | Not using EM2 and EM1 | / | MBR (Electromagnetic brake interlock) turns off without the forced stop deceleration. | | | | | | | | | | | | | | | | | | | | | | | | | | | | | | | | | | | | | |
| 21__ | Not using EM2 and EM1 | | MBR (Electromagnetic brake interlock) turns off after the forced stop deceleration. | | | | | | | | | | | | | | | | | | | | | | | | | | | | | | | | | | | | | |

5. PARAMETERS

| No. | Symbol | Name and function | Initial value [unit] | Setting range | Each/Common | | | | | | | | | | | | | | | | | | |
|------------------------------------------------------------------------------------------------------------------------------------------------------------------------------------------------------------------------------------------------------------------------------------------------------------------------------------------------------------------------------------------------------------------------------------------------------------------------------------------------------------------------------------------------------------------------------------------------------------------------------------------------------------------------------------------------------------------------------------------------------------------------------------------------------------------------------------------------------------------------------------------------------------------------------------------------------------------------------------------------------------------------------------------------------------------------------------------------------------------------------------------------------------------------------------------------------------------------------------------------------------------------------------------------------------------------------------------------------------------------------------|--------------------------------------------------------------------------------------------------------------------------------------------------------------------------------------------------------------------------|--------------------------------------------------------------------------------------------------------------------------------------------------------------------------------------------------------|------------------------------------|---------------|-------------|---------------|----------------------|----------------------------------|------|--------------------------------------------------------------------------------------------------------------------------------------------------------------------------------------------------------------------------|--------------------------------------------------------------------------------------------------------------------------------------------------------------------------|------|--------------------------|--------------------------------------------------------------------------------------------------------------------------------------------------------------------------------------------------------|------|--------------------|-------------------------------------------------------------------------------------------------------------------------------------|------|-------------|--|------|--------------------------|-------------------------------------------------------------------------------------------------------|
| PA08 | ATU | Auto tuning mode Select a gain adjustment mode. | Refer to Name and function column. | | Each | | | | | | | | | | | | | | | | | | |
| <table border="1"> <thead> <tr> <th>Setting digit</th> <th>Explanation</th> <th>Initial value</th> </tr> </thead> <tbody> <tr> <td>___x</td> <td> Gain adjustment mode selection 0: 2 gain adjustment mode 1 (interpolation mode) 1: Auto tuning mode 1 2: Auto tuning mode 2 3: Manual mode 4: 2 gain adjustment mode 2 Refer to table 5.2 for details. </td> <td>1h</td> </tr> <tr> <td>__x_</td> <td rowspan="3">For manufacturer setting</td> <td>0h</td> </tr> <tr> <td>_x__</td> <td>0h</td> </tr> <tr> <td>x___</td> <td>0h</td> </tr> </tbody> </table> | | | | | | Setting digit | Explanation | Initial value | ___x | Gain adjustment mode selection 0: 2 gain adjustment mode 1 (interpolation mode) 1: Auto tuning mode 1 2: Auto tuning mode 2 3: Manual mode 4: 2 gain adjustment mode 2 Refer to table 5.2 for details. | 1h | __x_ | For manufacturer setting | 0h | _x__ | 0h | x___ | 0h | | | | | |
| Setting digit | Explanation | Initial value | | | | | | | | | | | | | | | | | | | | | |
| ___x | Gain adjustment mode selection 0: 2 gain adjustment mode 1 (interpolation mode) 1: Auto tuning mode 1 2: Auto tuning mode 2 3: Manual mode 4: 2 gain adjustment mode 2 Refer to table 5.2 for details. | 1h | | | | | | | | | | | | | | | | | | | | | |
| __x_ | For manufacturer setting | 0h | | | | | | | | | | | | | | | | | | | | | |
| _x__ | | 0h | | | | | | | | | | | | | | | | | | | | | |
| x___ | | 0h | | | | | | | | | | | | | | | | | | | | | |
| Table 5.2 Gain adjustment mode selection | | | | | | | | | | | | | | | | | | | | | | | |
| <table border="1"> <thead> <tr> <th>Setting value</th> <th>Gain adjustment mode</th> <th>Automatically adjusted parameter</th> </tr> </thead> <tbody> <tr> <td>___0</td> <td>2 gain adjustment mode 1 (interpolation mode)</td> <td> [Pr. PB06 Load to motor inertia ratio/load to motor mass ratio] [Pr. PB08 Position loop gain] [Pr. PB09 Speed loop gain] [Pr. PB10 Speed integral compensation] </td> </tr> <tr> <td>___1</td> <td>Auto tuning mode 1</td> <td> [Pr. PB06 Load to motor inertia ratio/load to motor mass ratio] [Pr. PB07 Model loop gain] [Pr. PB08 Position loop gain] [Pr. PB09 Speed loop gain] [Pr. PB10 Speed integral compensation] </td> </tr> <tr> <td>___2</td> <td>Auto tuning mode 2</td> <td> [Pr. PB07 Model loop gain] [Pr. PB08 Position loop gain] [Pr. PB09 Speed loop gain] [Pr. PB10 Speed integral compensation] </td> </tr> <tr> <td>___3</td> <td>Manual mode</td> <td></td> </tr> <tr> <td>___4</td> <td>2 gain adjustment mode 2</td> <td> [Pr. PB08 Position loop gain] [Pr. PB09 Speed loop gain] [Pr. PB10 Speed integral compensation] </td> </tr> </tbody> </table> | | | | | | Setting value | Gain adjustment mode | Automatically adjusted parameter | ___0 | 2 gain adjustment mode 1 (interpolation mode) | [Pr. PB06 Load to motor inertia ratio/load to motor mass ratio] [Pr. PB08 Position loop gain] [Pr. PB09 Speed loop gain] [Pr. PB10 Speed integral compensation] | ___1 | Auto tuning mode 1 | [Pr. PB06 Load to motor inertia ratio/load to motor mass ratio] [Pr. PB07 Model loop gain] [Pr. PB08 Position loop gain] [Pr. PB09 Speed loop gain] [Pr. PB10 Speed integral compensation] | ___2 | Auto tuning mode 2 | [Pr. PB07 Model loop gain] [Pr. PB08 Position loop gain] [Pr. PB09 Speed loop gain] [Pr. PB10 Speed integral compensation] | ___3 | Manual mode | | ___4 | 2 gain adjustment mode 2 | [Pr. PB08 Position loop gain] [Pr. PB09 Speed loop gain] [Pr. PB10 Speed integral compensation] |
| Setting value | Gain adjustment mode | Automatically adjusted parameter | | | | | | | | | | | | | | | | | | | | | |
| ___0 | 2 gain adjustment mode 1 (interpolation mode) | [Pr. PB06 Load to motor inertia ratio/load to motor mass ratio] [Pr. PB08 Position loop gain] [Pr. PB09 Speed loop gain] [Pr. PB10 Speed integral compensation] | | | | | | | | | | | | | | | | | | | | | |
| ___1 | Auto tuning mode 1 | [Pr. PB06 Load to motor inertia ratio/load to motor mass ratio] [Pr. PB07 Model loop gain] [Pr. PB08 Position loop gain] [Pr. PB09 Speed loop gain] [Pr. PB10 Speed integral compensation] | | | | | | | | | | | | | | | | | | | | | |
| ___2 | Auto tuning mode 2 | [Pr. PB07 Model loop gain] [Pr. PB08 Position loop gain] [Pr. PB09 Speed loop gain] [Pr. PB10 Speed integral compensation] | | | | | | | | | | | | | | | | | | | | | |
| ___3 | Manual mode | | | | | | | | | | | | | | | | | | | | | | |
| ___4 | 2 gain adjustment mode 2 | [Pr. PB08 Position loop gain] [Pr. PB09 Speed loop gain] [Pr. PB10 Speed integral compensation] | | | | | | | | | | | | | | | | | | | | | |

5. PARAMETERS

| No. | Symbol | Name and function | Initial value [unit] | Setting range | Each/ Common | | | | | | | | | | | | | | | | | | | | | | | | | | | | | | | | | | | | | | | | | | | | | | | | | | | | | | | | | | | | | | | | | | | | | | | | | | | | | | | | | | | | | | | | | | | | | | |
|---------------|----------------------------|-----------------------------------------------------------------------------------------------------------------------------------------------------------------------------------------------------------------------------------------------------------------------------------------------------------------------------------------------------------------------------------------------------------------------------------------------------------------------------------------------------------------------------------------------------------------------------------------------------------------------------------------------------------------------------------------------------------------------------------------------------------------------------------------------------------------------------------------------------------------------------------------------------------------------------------------------------------------------------------------------------------------------------------------------------------------------------------------------------------------------------------------------------------------------------------------------------------------------------------------------------------------------------------------------------------------------------------------------------------------------------------------------------------------------------------------------------------------------------------------------------------------------------------------------------------------------------------------------------------------------------------------------------------------------------------------------------------------------------------------------------------------------------------------------------------------------------------------------------------------------------------------------------------------------------------------------------------------------------------------------------------------------------------------------------------------------------------------------------------------------------------------------------------------------------------------------------------------------------------------------------------------------------------------------------------------------------------------------|----------------------|-------------------------------|------------------------------------------------|---------------|------------------------|--|----------|------------------------------------------------|----------|------------------------------------------------|---|----------------------------|-----|----|-------------------------------|------|---|-----|----|------|---|-----|----|------|---|-----|----|------|---|------|----|-------|---|------|----|-------|---|------|----|-------|---|------|----|-------|---|------|----|-------|----|------|----|-------|----|------|----|-------|----|------|----|-------|----|------|----|-------|----|------|----|-------|----|------|----|-------|----|------|----|-------|----|------|----|-------|----|------|----|-------|----|---------------------------|------|----|-------------------------|-------|----|------|----|-------|----|---------|------|
| PA09 | RSP | Auto tuning response Set a response of the auto tuning. <table border="1" style="width: 100%; border-collapse: collapse;"> <thead> <tr> <th rowspan="2">Setting value</th> <th colspan="2">Machine characteristic</th> <th rowspan="2">Setting value</th> <th colspan="2">Machine characteristic</th> </tr> <tr> <th>Response</th> <th>Guideline for machine resonance frequency [Hz]</th> <th>Response</th> <th>Guideline for machine resonance frequency [Hz]</th> </tr> </thead> <tbody> <tr> <td>1</td> <td rowspan="18" style="text-align: center; vertical-align: middle;"> ↑ Low response ↓ </td> <td>2.7</td> <td>21</td> <td rowspan="18" style="text-align: center; vertical-align: middle;"> ↑ Middle response ↓ </td> <td>67.1</td> </tr> <tr><td>2</td><td>3.6</td><td>22</td><td>75.6</td></tr> <tr><td>3</td><td>4.9</td><td>23</td><td>85.2</td></tr> <tr><td>4</td><td>6.6</td><td>24</td><td>95.9</td></tr> <tr><td>5</td><td>10.0</td><td>25</td><td>108.0</td></tr> <tr><td>6</td><td>11.3</td><td>26</td><td>121.7</td></tr> <tr><td>7</td><td>12.7</td><td>27</td><td>137.1</td></tr> <tr><td>8</td><td>14.3</td><td>28</td><td>154.4</td></tr> <tr><td>9</td><td>16.1</td><td>29</td><td>173.9</td></tr> <tr><td>10</td><td>18.1</td><td>30</td><td>195.9</td></tr> <tr><td>11</td><td>20.4</td><td>31</td><td>220.6</td></tr> <tr><td>12</td><td>23.0</td><td>32</td><td>248.5</td></tr> <tr><td>13</td><td>25.9</td><td>33</td><td>279.9</td></tr> <tr><td>14</td><td>29.2</td><td>34</td><td>315.3</td></tr> <tr><td>15</td><td>32.9</td><td>35</td><td>355.1</td></tr> <tr><td>16</td><td>37.0</td><td>36</td><td>400.0</td></tr> <tr><td>17</td><td>41.7</td><td>37</td><td>446.6</td></tr> <tr><td>18</td><td>47.0</td><td>38</td><td>501.2</td></tr> <tr> <td>19</td> <td rowspan="2" style="text-align: center; vertical-align: middle;"> ↓ Middle response ↓ </td> <td>52.9</td> <td>39</td> <td rowspan="2" style="text-align: center; vertical-align: middle;"> ↓ High response ↓ </td> <td>571.5</td> </tr> <tr> <td>20</td> <td>59.6</td> <td>40</td> <td>642.7</td> </tr> </tbody> </table> | Setting value | Machine characteristic | | Setting value | Machine characteristic | | Response | Guideline for machine resonance frequency [Hz] | Response | Guideline for machine resonance frequency [Hz] | 1 | ↑ Low response ↓ | 2.7 | 21 | ↑ Middle response ↓ | 67.1 | 2 | 3.6 | 22 | 75.6 | 3 | 4.9 | 23 | 85.2 | 4 | 6.6 | 24 | 95.9 | 5 | 10.0 | 25 | 108.0 | 6 | 11.3 | 26 | 121.7 | 7 | 12.7 | 27 | 137.1 | 8 | 14.3 | 28 | 154.4 | 9 | 16.1 | 29 | 173.9 | 10 | 18.1 | 30 | 195.9 | 11 | 20.4 | 31 | 220.6 | 12 | 23.0 | 32 | 248.5 | 13 | 25.9 | 33 | 279.9 | 14 | 29.2 | 34 | 315.3 | 15 | 32.9 | 35 | 355.1 | 16 | 37.0 | 36 | 400.0 | 17 | 41.7 | 37 | 446.6 | 18 | 47.0 | 38 | 501.2 | 19 | ↓ Middle response ↓ | 52.9 | 39 | ↓ High response ↓ | 571.5 | 20 | 59.6 | 40 | 642.7 | 16 | 1 to 40 | Each |
| Setting value | Machine characteristic | | | Setting value | Machine characteristic | | | | | | | | | | | | | | | | | | | | | | | | | | | | | | | | | | | | | | | | | | | | | | | | | | | | | | | | | | | | | | | | | | | | | | | | | | | | | | | | | | | | | | | | | | | | | | |
| | Response | Guideline for machine resonance frequency [Hz] | Response | | Guideline for machine resonance frequency [Hz] | | | | | | | | | | | | | | | | | | | | | | | | | | | | | | | | | | | | | | | | | | | | | | | | | | | | | | | | | | | | | | | | | | | | | | | | | | | | | | | | | | | | | | | | | | | | | | |
| 1 | ↑ Low response ↓ | 2.7 | 21 | ↑ Middle response ↓ | 67.1 | | | | | | | | | | | | | | | | | | | | | | | | | | | | | | | | | | | | | | | | | | | | | | | | | | | | | | | | | | | | | | | | | | | | | | | | | | | | | | | | | | | | | | | | | | | | | | |
| 2 | | 3.6 | 22 | | 75.6 | | | | | | | | | | | | | | | | | | | | | | | | | | | | | | | | | | | | | | | | | | | | | | | | | | | | | | | | | | | | | | | | | | | | | | | | | | | | | | | | | | | | | | | | | | | | | | |
| 3 | | 4.9 | 23 | | 85.2 | | | | | | | | | | | | | | | | | | | | | | | | | | | | | | | | | | | | | | | | | | | | | | | | | | | | | | | | | | | | | | | | | | | | | | | | | | | | | | | | | | | | | | | | | | | | | | |
| 4 | | 6.6 | 24 | | 95.9 | | | | | | | | | | | | | | | | | | | | | | | | | | | | | | | | | | | | | | | | | | | | | | | | | | | | | | | | | | | | | | | | | | | | | | | | | | | | | | | | | | | | | | | | | | | | | | |
| 5 | | 10.0 | 25 | | 108.0 | | | | | | | | | | | | | | | | | | | | | | | | | | | | | | | | | | | | | | | | | | | | | | | | | | | | | | | | | | | | | | | | | | | | | | | | | | | | | | | | | | | | | | | | | | | | | | |
| 6 | | 11.3 | 26 | | 121.7 | | | | | | | | | | | | | | | | | | | | | | | | | | | | | | | | | | | | | | | | | | | | | | | | | | | | | | | | | | | | | | | | | | | | | | | | | | | | | | | | | | | | | | | | | | | | | | |
| 7 | | 12.7 | 27 | | 137.1 | | | | | | | | | | | | | | | | | | | | | | | | | | | | | | | | | | | | | | | | | | | | | | | | | | | | | | | | | | | | | | | | | | | | | | | | | | | | | | | | | | | | | | | | | | | | | | |
| 8 | | 14.3 | 28 | | 154.4 | | | | | | | | | | | | | | | | | | | | | | | | | | | | | | | | | | | | | | | | | | | | | | | | | | | | | | | | | | | | | | | | | | | | | | | | | | | | | | | | | | | | | | | | | | | | | | |
| 9 | | 16.1 | 29 | | 173.9 | | | | | | | | | | | | | | | | | | | | | | | | | | | | | | | | | | | | | | | | | | | | | | | | | | | | | | | | | | | | | | | | | | | | | | | | | | | | | | | | | | | | | | | | | | | | | | |
| 10 | | 18.1 | 30 | | 195.9 | | | | | | | | | | | | | | | | | | | | | | | | | | | | | | | | | | | | | | | | | | | | | | | | | | | | | | | | | | | | | | | | | | | | | | | | | | | | | | | | | | | | | | | | | | | | | | |
| 11 | | 20.4 | 31 | | 220.6 | | | | | | | | | | | | | | | | | | | | | | | | | | | | | | | | | | | | | | | | | | | | | | | | | | | | | | | | | | | | | | | | | | | | | | | | | | | | | | | | | | | | | | | | | | | | | | |
| 12 | | 23.0 | 32 | | 248.5 | | | | | | | | | | | | | | | | | | | | | | | | | | | | | | | | | | | | | | | | | | | | | | | | | | | | | | | | | | | | | | | | | | | | | | | | | | | | | | | | | | | | | | | | | | | | | | |
| 13 | | 25.9 | 33 | | 279.9 | | | | | | | | | | | | | | | | | | | | | | | | | | | | | | | | | | | | | | | | | | | | | | | | | | | | | | | | | | | | | | | | | | | | | | | | | | | | | | | | | | | | | | | | | | | | | | |
| 14 | | 29.2 | 34 | | 315.3 | | | | | | | | | | | | | | | | | | | | | | | | | | | | | | | | | | | | | | | | | | | | | | | | | | | | | | | | | | | | | | | | | | | | | | | | | | | | | | | | | | | | | | | | | | | | | | |
| 15 | | 32.9 | 35 | | 355.1 | | | | | | | | | | | | | | | | | | | | | | | | | | | | | | | | | | | | | | | | | | | | | | | | | | | | | | | | | | | | | | | | | | | | | | | | | | | | | | | | | | | | | | | | | | | | | | |
| 16 | | 37.0 | 36 | | 400.0 | | | | | | | | | | | | | | | | | | | | | | | | | | | | | | | | | | | | | | | | | | | | | | | | | | | | | | | | | | | | | | | | | | | | | | | | | | | | | | | | | | | | | | | | | | | | | | |
| 17 | | 41.7 | 37 | | 446.6 | | | | | | | | | | | | | | | | | | | | | | | | | | | | | | | | | | | | | | | | | | | | | | | | | | | | | | | | | | | | | | | | | | | | | | | | | | | | | | | | | | | | | | | | | | | | | | |
| 18 | | 47.0 | 38 | | 501.2 | | | | | | | | | | | | | | | | | | | | | | | | | | | | | | | | | | | | | | | | | | | | | | | | | | | | | | | | | | | | | | | | | | | | | | | | | | | | | | | | | | | | | | | | | | | | | | |
| 19 | ↓ Middle response ↓ | 52.9 | 39 | ↓ High response ↓ | 571.5 | | | | | | | | | | | | | | | | | | | | | | | | | | | | | | | | | | | | | | | | | | | | | | | | | | | | | | | | | | | | | | | | | | | | | | | | | | | | | | | | | | | | | | | | | | | | | | |
| 20 | | 59.6 | 40 | | 642.7 | | | | | | | | | | | | | | | | | | | | | | | | | | | | | | | | | | | | | | | | | | | | | | | | | | | | | | | | | | | | | | | | | | | | | | | | | | | | | | | | | | | | | | | | | | | | | | |
| PA10 | INP | In-position range Set an in-position range per command pulse. | 1600 [pulse] | 0 to 65535 | Each | | | | | | | | | | | | | | | | | | | | | | | | | | | | | | | | | | | | | | | | | | | | | | | | | | | | | | | | | | | | | | | | | | | | | | | | | | | | | | | | | | | | | | | | | | | | | | |

5. PARAMETERS

| No. | Symbol | Name and function | Initial value [unit] | Setting range | Each/ Common | | | | | | | | | | | |
|---------------|--------------------------------------------------------------------|-----------------------------------------------------------------------------------------------------------------------------------------------------------------------------------------------------------------------------------------------------------------------------------------------------------------------------------------------------------------------------------------------------------------------------------------------------------------------------------------------------------------------------------------------------------------------------------------------------------------------------------------------------------------------------------------------------------------------------------------------------------------------------------------------------------------------------------------------------------------------------------------------------------------------------------------------------------------------------------------------------------------------------------|----------------------|--------------------------------------------------------------------|--------------|------------------------------|------------------------------|---|---------------------------|--------------------------|---|--------------------------|---------------------------|---|--------|------|
| PA14 | *POL | <p>Rotation direction selection/travel direction selection</p> <p>Select command input pulses of the rotation direction or the travel direction of the rotary servo motor, the linear servo motor and the direct drive motor.</p> <table border="1"> <thead> <tr> <th rowspan="2">Setting value</th> <th colspan="2">Servo motor rotation direction/linear servo motor travel direction</th> </tr> <tr> <th>Positioning address increase</th> <th>Positioning address decrease</th> </tr> </thead> <tbody> <tr> <td>0</td> <td>CCW or positive direction</td> <td>CW or negative direction</td> </tr> <tr> <td>1</td> <td>CW or negative direction</td> <td>CCW or positive direction</td> </tr> </tbody> </table> <p>The following shows the servo motor rotation directions.</p> <p>The positive/negative directions of the linear servo motor are as follows.</p> <p style="text-align: center;"> LM-H3 series LM-U2 series LM-K2 series </p> | Setting value | Servo motor rotation direction/linear servo motor travel direction | | Positioning address increase | Positioning address decrease | 0 | CCW or positive direction | CW or negative direction | 1 | CW or negative direction | CCW or positive direction | 0 | 0 to 1 | Each |
| Setting value | Servo motor rotation direction/linear servo motor travel direction | | | | | | | | | | | | | | | |
| | Positioning address increase | Positioning address decrease | | | | | | | | | | | | | | |
| 0 | CCW or positive direction | CW or negative direction | | | | | | | | | | | | | | |
| 1 | CW or negative direction | CCW or positive direction | | | | | | | | | | | | | | |
| PA15 | *ENR | <p>Encoder output pulses</p> <p>Set the encoder output pulses from the servo amplifier by using the number of output pulses per revolution, dividing ratio, or electronic gear ratio. (after multiplication by 4)</p> <p>Set a numerator of the electronic gear, for when selecting "A-phase/B-phase pulse electronic gear setting (_ _ 3 _)" of "Encoder output pulse setting selection" in [Pr. PC03].</p> <p>The maximum output frequency is 4.6 Mpulses/s. Set the parameter within this range.</p> | 4000 [pulse/rev] | 1 to 65535 | Each | | | | | | | | | | | |
| PA16 | *ENR2 | <p>Encoder output pulses 2</p> <p>Set a denominator of the electronic gear, for when selecting "A-phase/B-phase pulse electronic gear setting (_ _ 3 _)" of "Encoder output pulse setting selection" in [Pr. PC03].</p> | 1 | 1 to 65535 | Each | | | | | | | | | | | |

5. PARAMETERS

| No. | Symbol | Name and function | Initial value [unit] | Setting range | Each/ Common | | | | | | | | | | | | | | | | | | | | | | | | | | | | | | | | | | | | | | | | | | | | | | | | | | | | | | | | | | | | | | |
|---------------------------|-----------------------------------|------------------------------------------------------------------------------------------------------------------------------------------------------------------------------------------------------------------------------------------------------------------------------------------------------------------------------------------------------------------------------------------------------------------------------------------------------------------------------------------------------------------------------------------------------------------------------------------------------------------------------------------------------------------------------------------------------------------------------------------------------------------------------------------------------------------------------------------------------------------------------------------------------------------------------------------------------------------------------------------------------------------------------------------------------------------------------------------------------------------------------------------------------------------------------------------------------------------------------------------------------------------------------------------------------------------------------------------------------------------------------------------------------------------------------------------------------------------------------------------------------------------------------------------------------------------------------------------------------------------------------------------------------------------------------------------------------------------------------------------------------------------------------------------------------------------------------------------------------------------------------------------------------------------------------------------------------------------------------------------------------------------------------------------------------------------------------------------------------------------------------------------------------------------------|---------------------------|--------------------------------------------------|--------------|--|--------------------|--------------------|-------|-------------------|-------|-------|-------------------|-------|-------------------|-------|-------------------|-------|-------------------|-------|-------------------|-------|-------------------|-------|-------------------|-------|-------------------|-------|-------|-------------------|-------|-------|-------------------|-------|-------------------|-------|-------------------|-------|-------------------|-------|-------------------|-------|-------------------|-------|-------------------|-------|-------------------|-------|-------|-------------------|-------|-------|-------------------|-------|-------------------|-------|-------------------|-------|-------------------|-------|-------------------|-------|-------------------|-------|-------|------------------------------------|------|
| PA17 | **MSR | <p>Servo motor series setting</p> <p>When using a linear servo motor, select any linear servo motor with [Pr. PA17] and [Pr. PA18]. Set this and [Pr. PA18] at a time.</p> <p>Refer to the following table for settings.</p> <p>This digit is not available with the MR-J4W2-0303B6 servo amplifier.</p> <table border="1" data-bbox="347 488 1155 1373"> <thead> <tr> <th rowspan="2">Linear servo motor series</th> <th rowspan="2">Linear servo motor (primary side)</th> <th colspan="2">Parameter</th> </tr> <tr> <th>[Pr. PA17] setting</th> <th>[Pr. PA18] setting</th> </tr> </thead> <tbody> <tr> <td rowspan="9">LM-H3</td> <td>LM-H3P2A-07P-BSS0</td> <td rowspan="9">00BBh</td> <td>2101h</td> </tr> <tr> <td>LM-H3P3A-12P-CSS0</td> <td>3101h</td> </tr> <tr> <td>LM-H3P3B-24P-CSS0</td> <td>3201h</td> </tr> <tr> <td>LM-H3P3C-36P-CSS0</td> <td>3301h</td> </tr> <tr> <td>LM-H3P3D-48P-CSS0</td> <td>3401h</td> </tr> <tr> <td>LM-H3P7A-24P-ASS0</td> <td>7101h</td> </tr> <tr> <td>LM-H3P7B-48P-ASS0</td> <td>7201h</td> </tr> <tr> <td>LM-H3P7C-72P-ASS0</td> <td>7301h</td> </tr> <tr> <td>LM-H3P7D-96P-ASS0</td> <td>7401h</td> </tr> <tr> <td rowspan="9">LM-U2</td> <td>LM-U2PAB-05M-0SS0</td> <td rowspan="9">00B4h</td> <td>A201h</td> </tr> <tr> <td>LM-U2PAD-10M-0SS0</td> <td>A401h</td> </tr> <tr> <td>LM-U2PAF-15M-0SS0</td> <td>A601h</td> </tr> <tr> <td>LM-U2PBB-07M-1SS0</td> <td>B201h</td> </tr> <tr> <td>LM-U2PBD-15M-1SS0</td> <td>B401h</td> </tr> <tr> <td>LM-U2PBF-22M-1SS0</td> <td>2601h</td> </tr> <tr> <td>LM-U2P2B-40M-2SS0</td> <td>2201h</td> </tr> <tr> <td>LM-U2P2C-60M-2SS0</td> <td>2301h</td> </tr> <tr> <td>LM-U2P2D-80M-2SS0</td> <td>2401h</td> </tr> <tr> <td rowspan="7">LM-K2</td> <td>LM-K2P1A-01M-2SS1</td> <td rowspan="7">00B8h</td> <td>1101h</td> </tr> <tr> <td>LM-K2P1C-03M-2SS1</td> <td>1301h</td> </tr> <tr> <td>LM-K2P2A-02M-1SS1</td> <td>2101h</td> </tr> <tr> <td>LM-K2P2C-07M-1SS1</td> <td>2301h</td> </tr> <tr> <td>LM-K2P2E-12M-1SS1</td> <td>2501h</td> </tr> <tr> <td>LM-K2P3C-14M-1SS1</td> <td>3301h</td> </tr> <tr> <td>LM-K2P3E-24M-1SS1</td> <td>3501h</td> </tr> </tbody> </table> | Linear servo motor series | Linear servo motor (primary side) | Parameter | | [Pr. PA17] setting | [Pr. PA18] setting | LM-H3 | LM-H3P2A-07P-BSS0 | 00BBh | 2101h | LM-H3P3A-12P-CSS0 | 3101h | LM-H3P3B-24P-CSS0 | 3201h | LM-H3P3C-36P-CSS0 | 3301h | LM-H3P3D-48P-CSS0 | 3401h | LM-H3P7A-24P-ASS0 | 7101h | LM-H3P7B-48P-ASS0 | 7201h | LM-H3P7C-72P-ASS0 | 7301h | LM-H3P7D-96P-ASS0 | 7401h | LM-U2 | LM-U2PAB-05M-0SS0 | 00B4h | A201h | LM-U2PAD-10M-0SS0 | A401h | LM-U2PAF-15M-0SS0 | A601h | LM-U2PBB-07M-1SS0 | B201h | LM-U2PBD-15M-1SS0 | B401h | LM-U2PBF-22M-1SS0 | 2601h | LM-U2P2B-40M-2SS0 | 2201h | LM-U2P2C-60M-2SS0 | 2301h | LM-U2P2D-80M-2SS0 | 2401h | LM-K2 | LM-K2P1A-01M-2SS1 | 00B8h | 1101h | LM-K2P1C-03M-2SS1 | 1301h | LM-K2P2A-02M-1SS1 | 2101h | LM-K2P2C-07M-1SS1 | 2301h | LM-K2P2E-12M-1SS1 | 2501h | LM-K2P3C-14M-1SS1 | 3301h | LM-K2P3E-24M-1SS1 | 3501h | 0000h | Refer to Name and function column. | Each |
| Linear servo motor series | Linear servo motor (primary side) | Parameter | | | | | | | | | | | | | | | | | | | | | | | | | | | | | | | | | | | | | | | | | | | | | | | | | | | | | | | | | | | | | | | | | |
| | | [Pr. PA17] setting | [Pr. PA18] setting | | | | | | | | | | | | | | | | | | | | | | | | | | | | | | | | | | | | | | | | | | | | | | | | | | | | | | | | | | | | | | | | |
| LM-H3 | LM-H3P2A-07P-BSS0 | 00BBh | 2101h | | | | | | | | | | | | | | | | | | | | | | | | | | | | | | | | | | | | | | | | | | | | | | | | | | | | | | | | | | | | | | | | |
| | LM-H3P3A-12P-CSS0 | | 3101h | | | | | | | | | | | | | | | | | | | | | | | | | | | | | | | | | | | | | | | | | | | | | | | | | | | | | | | | | | | | | | | | |
| | LM-H3P3B-24P-CSS0 | | 3201h | | | | | | | | | | | | | | | | | | | | | | | | | | | | | | | | | | | | | | | | | | | | | | | | | | | | | | | | | | | | | | | | |
| | LM-H3P3C-36P-CSS0 | | 3301h | | | | | | | | | | | | | | | | | | | | | | | | | | | | | | | | | | | | | | | | | | | | | | | | | | | | | | | | | | | | | | | | |
| | LM-H3P3D-48P-CSS0 | | 3401h | | | | | | | | | | | | | | | | | | | | | | | | | | | | | | | | | | | | | | | | | | | | | | | | | | | | | | | | | | | | | | | | |
| | LM-H3P7A-24P-ASS0 | | 7101h | | | | | | | | | | | | | | | | | | | | | | | | | | | | | | | | | | | | | | | | | | | | | | | | | | | | | | | | | | | | | | | | |
| | LM-H3P7B-48P-ASS0 | | 7201h | | | | | | | | | | | | | | | | | | | | | | | | | | | | | | | | | | | | | | | | | | | | | | | | | | | | | | | | | | | | | | | | |
| | LM-H3P7C-72P-ASS0 | | 7301h | | | | | | | | | | | | | | | | | | | | | | | | | | | | | | | | | | | | | | | | | | | | | | | | | | | | | | | | | | | | | | | | |
| | LM-H3P7D-96P-ASS0 | | 7401h | | | | | | | | | | | | | | | | | | | | | | | | | | | | | | | | | | | | | | | | | | | | | | | | | | | | | | | | | | | | | | | | |
| LM-U2 | LM-U2PAB-05M-0SS0 | 00B4h | A201h | | | | | | | | | | | | | | | | | | | | | | | | | | | | | | | | | | | | | | | | | | | | | | | | | | | | | | | | | | | | | | | | |
| | LM-U2PAD-10M-0SS0 | | A401h | | | | | | | | | | | | | | | | | | | | | | | | | | | | | | | | | | | | | | | | | | | | | | | | | | | | | | | | | | | | | | | | |
| | LM-U2PAF-15M-0SS0 | | A601h | | | | | | | | | | | | | | | | | | | | | | | | | | | | | | | | | | | | | | | | | | | | | | | | | | | | | | | | | | | | | | | | |
| | LM-U2PBB-07M-1SS0 | | B201h | | | | | | | | | | | | | | | | | | | | | | | | | | | | | | | | | | | | | | | | | | | | | | | | | | | | | | | | | | | | | | | | |
| | LM-U2PBD-15M-1SS0 | | B401h | | | | | | | | | | | | | | | | | | | | | | | | | | | | | | | | | | | | | | | | | | | | | | | | | | | | | | | | | | | | | | | | |
| | LM-U2PBF-22M-1SS0 | | 2601h | | | | | | | | | | | | | | | | | | | | | | | | | | | | | | | | | | | | | | | | | | | | | | | | | | | | | | | | | | | | | | | | |
| | LM-U2P2B-40M-2SS0 | | 2201h | | | | | | | | | | | | | | | | | | | | | | | | | | | | | | | | | | | | | | | | | | | | | | | | | | | | | | | | | | | | | | | | |
| | LM-U2P2C-60M-2SS0 | | 2301h | | | | | | | | | | | | | | | | | | | | | | | | | | | | | | | | | | | | | | | | | | | | | | | | | | | | | | | | | | | | | | | | |
| | LM-U2P2D-80M-2SS0 | | 2401h | | | | | | | | | | | | | | | | | | | | | | | | | | | | | | | | | | | | | | | | | | | | | | | | | | | | | | | | | | | | | | | | |
| LM-K2 | LM-K2P1A-01M-2SS1 | 00B8h | 1101h | | | | | | | | | | | | | | | | | | | | | | | | | | | | | | | | | | | | | | | | | | | | | | | | | | | | | | | | | | | | | | | | |
| | LM-K2P1C-03M-2SS1 | | 1301h | | | | | | | | | | | | | | | | | | | | | | | | | | | | | | | | | | | | | | | | | | | | | | | | | | | | | | | | | | | | | | | | |
| | LM-K2P2A-02M-1SS1 | | 2101h | | | | | | | | | | | | | | | | | | | | | | | | | | | | | | | | | | | | | | | | | | | | | | | | | | | | | | | | | | | | | | | | |
| | LM-K2P2C-07M-1SS1 | | 2301h | | | | | | | | | | | | | | | | | | | | | | | | | | | | | | | | | | | | | | | | | | | | | | | | | | | | | | | | | | | | | | | | |
| | LM-K2P2E-12M-1SS1 | | 2501h | | | | | | | | | | | | | | | | | | | | | | | | | | | | | | | | | | | | | | | | | | | | | | | | | | | | | | | | | | | | | | | | |
| | LM-K2P3C-14M-1SS1 | | 3301h | | | | | | | | | | | | | | | | | | | | | | | | | | | | | | | | | | | | | | | | | | | | | | | | | | | | | | | | | | | | | | | | |
| | LM-K2P3E-24M-1SS1 | | 3501h | | | | | | | | | | | | | | | | | | | | | | | | | | | | | | | | | | | | | | | | | | | | | | | | | | | | | | | | | | | | | | | | |
| PA18 | **MTY | <p>Servo motor type setting</p> <p>When using a linear servo motor, select any linear servo motor with [Pr. PA17] and [Pr. PA18]. Set this and [Pr. PA17] at a time.</p> <p>Refer to the table of [Pr. PA17] for settings.</p> <p>This digit is not available with the MR-J4W2-0303B6 servo amplifier.</p> | 0000h | Refer to Name and function column of [Pr. PA17]. | Each | | | | | | | | | | | | | | | | | | | | | | | | | | | | | | | | | | | | | | | | | | | | | | | | | | | | | | | | | | | | | | |

5. PARAMETERS

| No. | Symbol | Name and function | Initial value [unit] | Setting range | Each/ Common | | | | | | | | | | | | | | | | | | | | | | | | | | | | | | | | | | | | | | | | | | | | | | | | | | | | | | | | | | | | | | | | | | | | | | | | | | | | | | | | | | | | | | | | | | | | | | | | | | | | | | | | | | | | | | | | | | | | | | | | | | | | | | | | | | | | | | | | | | | | | | | | | | | | | | | | | | | | | | | | | | | | | | | | | | | | | | | | | | | | | | | | | | | | | | | | | | | | | | | | | | | | | | | | | | | | | |
|-----------------------|-------------------|---------------------------------------------------------------------------------------------------------------------------------------------------------------------------------------------------------------------------------------------------------------------------------------------------------------------------------------------------------------------------------------------------------------------------------------------------------------------------------------------------------------------------------------------------------------------------------------------------------------------------------------------------------------------------------------------------------------------------------------------------------------------------------------------------------------------------------------------------------------------------------------------------------------------------------------------------------------------------------------------------------------------------------------------------------------------------------------------------------------------------------------------------------------------------------------------------------------------------------------------------------------------------------------------------------------------------------------------------------------------------------------------------------------------------------------------------------------------------------------------------------------------------------------------------------------------------------------------------------------------------------------------------------------------------------------------------------------------------------------------------------------------------------------------------------------------------------------------------------------------------------------------------------------------------------------------------------------------------------------------------------------------------------------------------------------------------------------------------------------------------------------------------------------------------------------------------------------------------------------------------------------------------------------------------------------------------------------------------------------------------------------------------------------------------------------------------------------------------------------------------------------------------------------------------------------------------------------------------------------------------------------------------------------------------------------------------------------------------------------------------------------------------------------------------------------------------------------------------------------------------------------------------------------------------------------------------------------------------------------------------------------------------------------------------------------------------------------------------------------------------------------------------------------------------------------------------------------------------------------------------------------------------------------------------------------------------------------------------------------------------------------------------------------------------------------------------------------------------------------------------------------------------------------------------------------------------------------------------------------------------------------------------------------------------------------------------------------------------------------------------------------------------------------------------------------------------------------------------------------------------------------------------------------------------------------------------------------------------------------------------------------------------------------------------------------------------------------------------------------------------------------------------------------------------------------------------------------------------------------------------------------------------------------------------------------------------------------------------------------------------------------------------------------------------------------------------------------------------------------------------------------------------------------------------------------------------------------------------------------------------------------------------------------------------------------------------------------------------------------------------------------------------------------------------------------------------------------------------------------------------------------------------------------------------------------------------------------------------------------------------------------------------------------------------------------------------------------------------------------------------------------------------------------------------------------------------------------------------------------------------------------------------------------------------------------------------------------------------------------------------------------------------------------------------------------------------------------------------------------------------------------------------------------------------------------------------------------------------------------------------------------------------------------------------------------------------------------------------------------------------------------------------------------------------------------------------------------------------------------------------------------------------------------------------------------------------------------------------------------------------------------------------------------------------------------------------------------------------------------------------------------------------------------------------------------------------------------------------------------------------------------------------------------------------------------------------------------------------------------------------------------------------------------------------------------------------------------------------------------------------------------------------------------------------------------------------------------------------------------------------------------------------------------------------------------------------------------------------------------------------------------------------------------------------------------------------------------------------------------------------------------------------------------------------------------------------------------------------------------------------------------------------------------------------------------------------------------------------------------------------------------------------------------------------------------------------------------------------------------------------------------------------------------------------------------------------------------------------------------------------------------------------------------------------------------------------------------------------------------------------------------------------------------------------------------------------------------------------------------------------------------------------------------------------------------------------------------------------------------------------------------------------------------------------------------------------------------------------------------------------------------------------------------------------------------------------------------------------------------------------------------------------------------------------------------------------------------------------------------------------------------------------------------------------------------------------------------------------------------------------------------------------------------------------------------------------------------------------------------------------------------------------------------------------------------------------------------------------------------------------------------------------------------------------------------------|----------------------|-------------------|--------------|----|----|----|----|----|----|------------------|---------|---|---|---|---|---|---|---|---------|---|---|---|---|---|---|---|-------|---------|---------|---|---|---|---|---|---|---------|---------|---|---|---|---|---|---|-------|---------|---|---|---|---|---|---|---|---------|---|---|---|---|---|---|---|-------|---------|---|---|---|---|---|---|---|---------|---|---|---|---|---|---|---|-------|---------|---|---|---|---|---|---|---|---------|---|---|---|---|---|---|---|-------|---------|---|---|---|---|---|---|---|---------|---|---|---|---|---|---|---|-----------------------|---------|---|---|---|---|---|---|---|---------|---|---|---|---|---|---|---|-------|---------|---|---|---|---|---|---|---|---------|---------|---|---|---|---|---|---|-------|---------|---|---|---|---|---|---|---|---------|---------|---|---|---|---|---|---|-------|---------|---|---|---|---|---|---|---|---------|---------|---|---|---|---|---|---|-------|---------|---|---|---|---|---|---|---|---------|---------|---|---|---|---|---|---|-------|---------|---|---|---|---|---|---|---|---------|---------|---|---|---|---|---|---|-------|------------------------------------|------|
| PA19 | *BLK | <p>Parameter writing inhibit</p> <p>Select a reference range and writing range of the parameter.</p> <p>Refer to table 5.3 for settings.</p> <p>Linear servo motor/DD motor setting parameters ([Pr. PL_ _]) cannot be used with MR-J4W2-0303B6 servo amplifiers.</p> <p style="text-align: center;">Table 5.3 [Pr. PA19] setting value and reading/writing range</p> <table border="1" style="width: 100%; border-collapse: collapse;"> <thead> <tr> <th>PA19</th> <th>Setting operation</th> <th>PA</th> <th>PB</th> <th>PC</th> <th>PD</th> <th>PE</th> <th>PF</th> <th>PL</th> </tr> </thead> <tbody> <tr> <td rowspan="2">Other than below</td> <td>Reading</td> <td style="text-align: center;">○</td> <td style="text-align: center;">/</td> <td style="text-align: center;">/</td> <td style="text-align: center;">/</td> <td style="text-align: center;">/</td> <td style="text-align: center;">/</td> <td style="text-align: center;">/</td> </tr> <tr> <td>Writing</td> <td style="text-align: center;">○</td> <td style="text-align: center;">/</td> <td style="text-align: center;">/</td> <td style="text-align: center;">/</td> <td style="text-align: center;">/</td> <td style="text-align: center;">/</td> <td style="text-align: center;">/</td> </tr> <tr> <td rowspan="2">000Ah</td> <td>Reading</td> <td style="text-align: center;">Only 19</td> <td style="text-align: center;">/</td> <td style="text-align: center;">/</td> <td style="text-align: center;">/</td> <td style="text-align: center;">/</td> <td style="text-align: center;">/</td> <td style="text-align: center;">/</td> </tr> <tr> <td>Writing</td> <td style="text-align: center;">Only 19</td> <td style="text-align: center;">/</td> <td style="text-align: center;">/</td> <td style="text-align: center;">/</td> <td style="text-align: center;">/</td> <td style="text-align: center;">/</td> <td style="text-align: center;">/</td> </tr> <tr> <td rowspan="2">000Bh</td> <td>Reading</td> <td style="text-align: center;">○</td> <td style="text-align: center;">○</td> <td style="text-align: center;">○</td> <td style="text-align: center;">/</td> <td style="text-align: center;">/</td> <td style="text-align: center;">/</td> <td style="text-align: center;">/</td> </tr> <tr> <td>Writing</td> <td style="text-align: center;">○</td> <td style="text-align: center;">○</td> <td style="text-align: center;">○</td> <td style="text-align: center;">/</td> <td style="text-align: center;">/</td> <td style="text-align: center;">/</td> <td style="text-align: center;">/</td> </tr> <tr> <td rowspan="2">000Ch</td> <td>Reading</td> <td style="text-align: center;">○</td> <td style="text-align: center;">○</td> <td style="text-align: center;">○</td> <td style="text-align: center;">○</td> <td style="text-align: center;">/</td> <td style="text-align: center;">/</td> <td style="text-align: center;">/</td> </tr> <tr> <td>Writing</td> <td style="text-align: center;">○</td> <td style="text-align: center;">○</td> <td style="text-align: center;">○</td> <td style="text-align: center;">○</td> <td style="text-align: center;">/</td> <td style="text-align: center;">/</td> <td style="text-align: center;">/</td> </tr> <tr> <td rowspan="2">000Fh</td> <td>Reading</td> <td style="text-align: center;">○</td> <td style="text-align: center;">○</td> <td style="text-align: center;">○</td> <td style="text-align: center;">○</td> <td style="text-align: center;">○</td> <td style="text-align: center;">/</td> <td style="text-align: center;">○</td> </tr> <tr> <td>Writing</td> <td style="text-align: center;">○</td> <td style="text-align: center;">○</td> <td style="text-align: center;">○</td> <td style="text-align: center;">○</td> <td style="text-align: center;">○</td> <td style="text-align: center;">/</td> <td style="text-align: center;">○</td> </tr> <tr> <td rowspan="2">00AAh</td> <td>Reading</td> <td style="text-align: center;">○</td> <td style="text-align: center;">○</td> <td style="text-align: center;">○</td> <td style="text-align: center;">○</td> <td style="text-align: center;">○</td> <td style="text-align: center;">○</td> <td style="text-align: center;">/</td> </tr> <tr> <td>Writing</td> <td style="text-align: center;">○</td> <td style="text-align: center;">○</td> <td style="text-align: center;">○</td> <td style="text-align: center;">○</td> <td style="text-align: center;">○</td> <td style="text-align: center;">○</td> <td style="text-align: center;">/</td> </tr> <tr> <td rowspan="2">00ABh (initial value)</td> <td>Reading</td> <td style="text-align: center;">○</td> <td style="text-align: center;">○</td> <td style="text-align: center;">○</td> <td style="text-align: center;">○</td> <td style="text-align: center;">○</td> <td style="text-align: center;">○</td> <td style="text-align: center;">○</td> </tr> <tr> <td>Writing</td> <td style="text-align: center;">○</td> <td style="text-align: center;">○</td> <td style="text-align: center;">○</td> <td style="text-align: center;">○</td> <td style="text-align: center;">○</td> <td style="text-align: center;">○</td> <td style="text-align: center;">○</td> </tr> <tr> <td rowspan="2">100Bh</td> <td>Reading</td> <td style="text-align: center;">○</td> <td style="text-align: center;">/</td> <td style="text-align: center;">/</td> <td style="text-align: center;">/</td> <td style="text-align: center;">/</td> <td style="text-align: center;">/</td> <td style="text-align: center;">/</td> </tr> <tr> <td>Writing</td> <td style="text-align: center;">Only 19</td> <td style="text-align: center;">/</td> <td style="text-align: center;">/</td> <td style="text-align: center;">/</td> <td style="text-align: center;">/</td> <td style="text-align: center;">/</td> <td style="text-align: center;">/</td> </tr> <tr> <td rowspan="2">100Ch</td> <td>Reading</td> <td style="text-align: center;">○</td> <td style="text-align: center;">○</td> <td style="text-align: center;">○</td> <td style="text-align: center;">○</td> <td style="text-align: center;">/</td> <td style="text-align: center;">/</td> <td style="text-align: center;">/</td> </tr> <tr> <td>Writing</td> <td style="text-align: center;">Only 19</td> <td style="text-align: center;">/</td> <td style="text-align: center;">/</td> <td style="text-align: center;">/</td> <td style="text-align: center;">/</td> <td style="text-align: center;">/</td> <td style="text-align: center;">/</td> </tr> <tr> <td rowspan="2">100Fh</td> <td>Reading</td> <td style="text-align: center;">○</td> <td style="text-align: center;">○</td> <td style="text-align: center;">○</td> <td style="text-align: center;">○</td> <td style="text-align: center;">○</td> <td style="text-align: center;">/</td> <td style="text-align: center;">○</td> </tr> <tr> <td>Writing</td> <td style="text-align: center;">Only 19</td> <td style="text-align: center;">/</td> <td style="text-align: center;">/</td> <td style="text-align: center;">/</td> <td style="text-align: center;">/</td> <td style="text-align: center;">/</td> <td style="text-align: center;">/</td> </tr> <tr> <td rowspan="2">10AAh</td> <td>Reading</td> <td style="text-align: center;">○</td> <td style="text-align: center;">○</td> <td style="text-align: center;">○</td> <td style="text-align: center;">○</td> <td style="text-align: center;">○</td> <td style="text-align: center;">○</td> <td style="text-align: center;">/</td> </tr> <tr> <td>Writing</td> <td style="text-align: center;">Only 19</td> <td style="text-align: center;">/</td> <td style="text-align: center;">/</td> <td style="text-align: center;">/</td> <td style="text-align: center;">/</td> <td style="text-align: center;">/</td> <td style="text-align: center;">/</td> </tr> <tr> <td rowspan="2">10ABh</td> <td>Reading</td> <td style="text-align: center;">○</td> <td style="text-align: center;">○</td> <td style="text-align: center;">○</td> <td style="text-align: center;">○</td> <td style="text-align: center;">○</td> <td style="text-align: center;">○</td> <td style="text-align: center;">○</td> </tr> <tr> <td>Writing</td> <td style="text-align: center;">Only 19</td> <td style="text-align: center;">/</td> <td style="text-align: center;">/</td> <td style="text-align: center;">/</td> <td style="text-align: center;">/</td> <td style="text-align: center;">/</td> <td style="text-align: center;">/</td> </tr> </tbody> </table> | PA19 | Setting operation | PA | PB | PC | PD | PE | PF | PL | Other than below | Reading | ○ | / | / | / | / | / | / | Writing | ○ | / | / | / | / | / | / | 000Ah | Reading | Only 19 | / | / | / | / | / | / | Writing | Only 19 | / | / | / | / | / | / | 000Bh | Reading | ○ | ○ | ○ | / | / | / | / | Writing | ○ | ○ | ○ | / | / | / | / | 000Ch | Reading | ○ | ○ | ○ | ○ | / | / | / | Writing | ○ | ○ | ○ | ○ | / | / | / | 000Fh | Reading | ○ | ○ | ○ | ○ | ○ | / | ○ | Writing | ○ | ○ | ○ | ○ | ○ | / | ○ | 00AAh | Reading | ○ | ○ | ○ | ○ | ○ | ○ | / | Writing | ○ | ○ | ○ | ○ | ○ | ○ | / | 00ABh (initial value) | Reading | ○ | ○ | ○ | ○ | ○ | ○ | ○ | Writing | ○ | ○ | ○ | ○ | ○ | ○ | ○ | 100Bh | Reading | ○ | / | / | / | / | / | / | Writing | Only 19 | / | / | / | / | / | / | 100Ch | Reading | ○ | ○ | ○ | ○ | / | / | / | Writing | Only 19 | / | / | / | / | / | / | 100Fh | Reading | ○ | ○ | ○ | ○ | ○ | / | ○ | Writing | Only 19 | / | / | / | / | / | / | 10AAh | Reading | ○ | ○ | ○ | ○ | ○ | ○ | / | Writing | Only 19 | / | / | / | / | / | / | 10ABh | Reading | ○ | ○ | ○ | ○ | ○ | ○ | ○ | Writing | Only 19 | / | / | / | / | / | / | 00ABh | Refer to Name and function column. | Each |
| PA19 | Setting operation | PA | PB | PC | PD | PE | PF | PL | | | | | | | | | | | | | | | | | | | | | | | | | | | | | | | | | | | | | | | | | | | | | | | | | | | | | | | | | | | | | | | | | | | | | | | | | | | | | | | | | | | | | | | | | | | | | | | | | | | | | | | | | | | | | | | | | | | | | | | | | | | | | | | | | | | | | | | | | | | | | | | | | | | | | | | | | | | | | | | | | | | | | | | | | | | | | | | | | | | | | | | | | | | | | | | | | | | | | | | | | | | | | | | | | | |
| Other than below | Reading | ○ | / | / | / | / | / | / | | | | | | | | | | | | | | | | | | | | | | | | | | | | | | | | | | | | | | | | | | | | | | | | | | | | | | | | | | | | | | | | | | | | | | | | | | | | | | | | | | | | | | | | | | | | | | | | | | | | | | | | | | | | | | | | | | | | | | | | | | | | | | | | | | | | | | | | | | | | | | | | | | | | | | | | | | | | | | | | | | | | | | | | | | | | | | | | | | | | | | | | | | | | | | | | | | | | | | | | | | | | | | | | | | |
| | Writing | ○ | / | / | / | / | / | / | | | | | | | | | | | | | | | | | | | | | | | | | | | | | | | | | | | | | | | | | | | | | | | | | | | | | | | | | | | | | | | | | | | | | | | | | | | | | | | | | | | | | | | | | | | | | | | | | | | | | | | | | | | | | | | | | | | | | | | | | | | | | | | | | | | | | | | | | | | | | | | | | | | | | | | | | | | | | | | | | | | | | | | | | | | | | | | | | | | | | | | | | | | | | | | | | | | | | | | | | | | | | | | | | | |
| 000Ah | Reading | Only 19 | / | / | / | / | / | / | | | | | | | | | | | | | | | | | | | | | | | | | | | | | | | | | | | | | | | | | | | | | | | | | | | | | | | | | | | | | | | | | | | | | | | | | | | | | | | | | | | | | | | | | | | | | | | | | | | | | | | | | | | | | | | | | | | | | | | | | | | | | | | | | | | | | | | | | | | | | | | | | | | | | | | | | | | | | | | | | | | | | | | | | | | | | | | | | | | | | | | | | | | | | | | | | | | | | | | | | | | | | | | | | | |
| | Writing | Only 19 | / | / | / | / | / | / | | | | | | | | | | | | | | | | | | | | | | | | | | | | | | | | | | | | | | | | | | | | | | | | | | | | | | | | | | | | | | | | | | | | | | | | | | | | | | | | | | | | | | | | | | | | | | | | | | | | | | | | | | | | | | | | | | | | | | | | | | | | | | | | | | | | | | | | | | | | | | | | | | | | | | | | | | | | | | | | | | | | | | | | | | | | | | | | | | | | | | | | | | | | | | | | | | | | | | | | | | | | | | | | | | |
| 000Bh | Reading | ○ | ○ | ○ | / | / | / | / | | | | | | | | | | | | | | | | | | | | | | | | | | | | | | | | | | | | | | | | | | | | | | | | | | | | | | | | | | | | | | | | | | | | | | | | | | | | | | | | | | | | | | | | | | | | | | | | | | | | | | | | | | | | | | | | | | | | | | | | | | | | | | | | | | | | | | | | | | | | | | | | | | | | | | | | | | | | | | | | | | | | | | | | | | | | | | | | | | | | | | | | | | | | | | | | | | | | | | | | | | | | | | | | | | |
| | Writing | ○ | ○ | ○ | / | / | / | / | | | | | | | | | | | | | | | | | | | | | | | | | | | | | | | | | | | | | | | | | | | | | | | | | | | | | | | | | | | | | | | | | | | | | | | | | | | | | | | | | | | | | | | | | | | | | | | | | | | | | | | | | | | | | | | | | | | | | | | | | | | | | | | | | | | | | | | | | | | | | | | | | | | | | | | | | | | | | | | | | | | | | | | | | | | | | | | | | | | | | | | | | | | | | | | | | | | | | | | | | | | | | | | | | | |
| 000Ch | Reading | ○ | ○ | ○ | ○ | / | / | / | | | | | | | | | | | | | | | | | | | | | | | | | | | | | | | | | | | | | | | | | | | | | | | | | | | | | | | | | | | | | | | | | | | | | | | | | | | | | | | | | | | | | | | | | | | | | | | | | | | | | | | | | | | | | | | | | | | | | | | | | | | | | | | | | | | | | | | | | | | | | | | | | | | | | | | | | | | | | | | | | | | | | | | | | | | | | | | | | | | | | | | | | | | | | | | | | | | | | | | | | | | | | | | | | | |
| | Writing | ○ | ○ | ○ | ○ | / | / | / | | | | | | | | | | | | | | | | | | | | | | | | | | | | | | | | | | | | | | | | | | | | | | | | | | | | | | | | | | | | | | | | | | | | | | | | | | | | | | | | | | | | | | | | | | | | | | | | | | | | | | | | | | | | | | | | | | | | | | | | | | | | | | | | | | | | | | | | | | | | | | | | | | | | | | | | | | | | | | | | | | | | | | | | | | | | | | | | | | | | | | | | | | | | | | | | | | | | | | | | | | | | | | | | | | |
| 000Fh | Reading | ○ | ○ | ○ | ○ | ○ | / | ○ | | | | | | | | | | | | | | | | | | | | | | | | | | | | | | | | | | | | | | | | | | | | | | | | | | | | | | | | | | | | | | | | | | | | | | | | | | | | | | | | | | | | | | | | | | | | | | | | | | | | | | | | | | | | | | | | | | | | | | | | | | | | | | | | | | | | | | | | | | | | | | | | | | | | | | | | | | | | | | | | | | | | | | | | | | | | | | | | | | | | | | | | | | | | | | | | | | | | | | | | | | | | | | | | | | |
| | Writing | ○ | ○ | ○ | ○ | ○ | / | ○ | | | | | | | | | | | | | | | | | | | | | | | | | | | | | | | | | | | | | | | | | | | | | | | | | | | | | | | | | | | | | | | | | | | | | | | | | | | | | | | | | | | | | | | | | | | | | | | | | | | | | | | | | | | | | | | | | | | | | | | | | | | | | | | | | | | | | | | | | | | | | | | | | | | | | | | | | | | | | | | | | | | | | | | | | | | | | | | | | | | | | | | | | | | | | | | | | | | | | | | | | | | | | | | | | | |
| 00AAh | Reading | ○ | ○ | ○ | ○ | ○ | ○ | / | | | | | | | | | | | | | | | | | | | | | | | | | | | | | | | | | | | | | | | | | | | | | | | | | | | | | | | | | | | | | | | | | | | | | | | | | | | | | | | | | | | | | | | | | | | | | | | | | | | | | | | | | | | | | | | | | | | | | | | | | | | | | | | | | | | | | | | | | | | | | | | | | | | | | | | | | | | | | | | | | | | | | | | | | | | | | | | | | | | | | | | | | | | | | | | | | | | | | | | | | | | | | | | | | | |
| | Writing | ○ | ○ | ○ | ○ | ○ | ○ | / | | | | | | | | | | | | | | | | | | | | | | | | | | | | | | | | | | | | | | | | | | | | | | | | | | | | | | | | | | | | | | | | | | | | | | | | | | | | | | | | | | | | | | | | | | | | | | | | | | | | | | | | | | | | | | | | | | | | | | | | | | | | | | | | | | | | | | | | | | | | | | | | | | | | | | | | | | | | | | | | | | | | | | | | | | | | | | | | | | | | | | | | | | | | | | | | | | | | | | | | | | | | | | | | | | |
| 00ABh (initial value) | Reading | ○ | ○ | ○ | ○ | ○ | ○ | ○ | | | | | | | | | | | | | | | | | | | | | | | | | | | | | | | | | | | | | | | | | | | | | | | | | | | | | | | | | | | | | | | | | | | | | | | | | | | | | | | | | | | | | | | | | | | | | | | | | | | | | | | | | | | | | | | | | | | | | | | | | | | | | | | | | | | | | | | | | | | | | | | | | | | | | | | | | | | | | | | | | | | | | | | | | | | | | | | | | | | | | | | | | | | | | | | | | | | | | | | | | | | | | | | | | | |
| | Writing | ○ | ○ | ○ | ○ | ○ | ○ | ○ | | | | | | | | | | | | | | | | | | | | | | | | | | | | | | | | | | | | | | | | | | | | | | | | | | | | | | | | | | | | | | | | | | | | | | | | | | | | | | | | | | | | | | | | | | | | | | | | | | | | | | | | | | | | | | | | | | | | | | | | | | | | | | | | | | | | | | | | | | | | | | | | | | | | | | | | | | | | | | | | | | | | | | | | | | | | | | | | | | | | | | | | | | | | | | | | | | | | | | | | | | | | | | | | | | |
| 100Bh | Reading | ○ | / | / | / | / | / | / | | | | | | | | | | | | | | | | | | | | | | | | | | | | | | | | | | | | | | | | | | | | | | | | | | | | | | | | | | | | | | | | | | | | | | | | | | | | | | | | | | | | | | | | | | | | | | | | | | | | | | | | | | | | | | | | | | | | | | | | | | | | | | | | | | | | | | | | | | | | | | | | | | | | | | | | | | | | | | | | | | | | | | | | | | | | | | | | | | | | | | | | | | | | | | | | | | | | | | | | | | | | | | | | | | |
| | Writing | Only 19 | / | / | / | / | / | / | | | | | | | | | | | | | | | | | | | | | | | | | | | | | | | | | | | | | | | | | | | | | | | | | | | | | | | | | | | | | | | | | | | | | | | | | | | | | | | | | | | | | | | | | | | | | | | | | | | | | | | | | | | | | | | | | | | | | | | | | | | | | | | | | | | | | | | | | | | | | | | | | | | | | | | | | | | | | | | | | | | | | | | | | | | | | | | | | | | | | | | | | | | | | | | | | | | | | | | | | | | | | | | | | | |
| 100Ch | Reading | ○ | ○ | ○ | ○ | / | / | / | | | | | | | | | | | | | | | | | | | | | | | | | | | | | | | | | | | | | | | | | | | | | | | | | | | | | | | | | | | | | | | | | | | | | | | | | | | | | | | | | | | | | | | | | | | | | | | | | | | | | | | | | | | | | | | | | | | | | | | | | | | | | | | | | | | | | | | | | | | | | | | | | | | | | | | | | | | | | | | | | | | | | | | | | | | | | | | | | | | | | | | | | | | | | | | | | | | | | | | | | | | | | | | | | | |
| | Writing | Only 19 | / | / | / | / | / | / | | | | | | | | | | | | | | | | | | | | | | | | | | | | | | | | | | | | | | | | | | | | | | | | | | | | | | | | | | | | | | | | | | | | | | | | | | | | | | | | | | | | | | | | | | | | | | | | | | | | | | | | | | | | | | | | | | | | | | | | | | | | | | | | | | | | | | | | | | | | | | | | | | | | | | | | | | | | | | | | | | | | | | | | | | | | | | | | | | | | | | | | | | | | | | | | | | | | | | | | | | | | | | | | | | |
| 100Fh | Reading | ○ | ○ | ○ | ○ | ○ | / | ○ | | | | | | | | | | | | | | | | | | | | | | | | | | | | | | | | | | | | | | | | | | | | | | | | | | | | | | | | | | | | | | | | | | | | | | | | | | | | | | | | | | | | | | | | | | | | | | | | | | | | | | | | | | | | | | | | | | | | | | | | | | | | | | | | | | | | | | | | | | | | | | | | | | | | | | | | | | | | | | | | | | | | | | | | | | | | | | | | | | | | | | | | | | | | | | | | | | | | | | | | | | | | | | | | | | |
| | Writing | Only 19 | / | / | / | / | / | / | | | | | | | | | | | | | | | | | | | | | | | | | | | | | | | | | | | | | | | | | | | | | | | | | | | | | | | | | | | | | | | | | | | | | | | | | | | | | | | | | | | | | | | | | | | | | | | | | | | | | | | | | | | | | | | | | | | | | | | | | | | | | | | | | | | | | | | | | | | | | | | | | | | | | | | | | | | | | | | | | | | | | | | | | | | | | | | | | | | | | | | | | | | | | | | | | | | | | | | | | | | | | | | | | | |
| 10AAh | Reading | ○ | ○ | ○ | ○ | ○ | ○ | / | | | | | | | | | | | | | | | | | | | | | | | | | | | | | | | | | | | | | | | | | | | | | | | | | | | | | | | | | | | | | | | | | | | | | | | | | | | | | | | | | | | | | | | | | | | | | | | | | | | | | | | | | | | | | | | | | | | | | | | | | | | | | | | | | | | | | | | | | | | | | | | | | | | | | | | | | | | | | | | | | | | | | | | | | | | | | | | | | | | | | | | | | | | | | | | | | | | | | | | | | | | | | | | | | | |
| | Writing | Only 19 | / | / | / | / | / | / | | | | | | | | | | | | | | | | | | | | | | | | | | | | | | | | | | | | | | | | | | | | | | | | | | | | | | | | | | | | | | | | | | | | | | | | | | | | | | | | | | | | | | | | | | | | | | | | | | | | | | | | | | | | | | | | | | | | | | | | | | | | | | | | | | | | | | | | | | | | | | | | | | | | | | | | | | | | | | | | | | | | | | | | | | | | | | | | | | | | | | | | | | | | | | | | | | | | | | | | | | | | | | | | | | |
| 10ABh | Reading | ○ | ○ | ○ | ○ | ○ | ○ | ○ | | | | | | | | | | | | | | | | | | | | | | | | | | | | | | | | | | | | | | | | | | | | | | | | | | | | | | | | | | | | | | | | | | | | | | | | | | | | | | | | | | | | | | | | | | | | | | | | | | | | | | | | | | | | | | | | | | | | | | | | | | | | | | | | | | | | | | | | | | | | | | | | | | | | | | | | | | | | | | | | | | | | | | | | | | | | | | | | | | | | | | | | | | | | | | | | | | | | | | | | | | | | | | | | | | |
| | Writing | Only 19 | / | / | / | / | / | / | | | | | | | | | | | | | | | | | | | | | | | | | | | | | | | | | | | | | | | | | | | | | | | | | | | | | | | | | | | | | | | | | | | | | | | | | | | | | | | | | | | | | | | | | | | | | | | | | | | | | | | | | | | | | | | | | | | | | | | | | | | | | | | | | | | | | | | | | | | | | | | | | | | | | | | | | | | | | | | | | | | | | | | | | | | | | | | | | | | | | | | | | | | | | | | | | | | | | | | | | | | | | | | | | | |

5. PARAMETERS

| No. | Symbol | Name and function | Initial value [unit] | Setting range | Each/ Common | | | | | | | | | | | | | | | |
|---------------|---------------------------------------------------------------------------------------------------------------------------------------------------------------------------------------------------------------------------------------------------------------------------------------------------------------------------------------------------------------------------------------------------------------------------------------------------------------------------------------------------------------------------------------------------------------------------------------------------------------------------|------------------------------------------------------------------------------------------------------------------------------------------------------------------------------------------------------------------------------------------------------------------------------------------------------------------------------------------------------------------------------------------------------------------------------------------------------------------------------------------------------------------------------------------------------------------------------------------------------------------------------------------------------------------------------------------------------------------------------------------------------------------------------------------------------------------------------------------------------------------------------------------------------------------------------------------------------------------------------------------------------------------------------------------------------------------------------------------------------------------------------------------------------------------------------------------------------------------------------------------------------------------------------------------------------------------------------------------------------------------------------------------------------------------------------------------------------------------------------------------------------------------------------------------------------------------------------------------------------------------------------------------------------------------------------------------------------------------------------------------------------------------------------------------------------------------|----------------------|---------------|---------------|------|-------------------------------------------------------------------------------------------------------------------------------------------------------------|----|------|-------------------------------------------------------------------------------------------------------------------------------------------------------------------------------------------------------------------------------------------------------------------------------------------------------------------------------------------------------------------------------------------------------|----|------|---------------------------------------------------------------------------------------------------------------------------------------------------------------------------------------------------------------------------------------------------------------------------------------------------------------------------------------------------------------------------------------------------------------------------------------------------------------------------------------------------------------------------------------------------------------------------------------------------------------------------|------|------|------------------------------------|----|------------------------------------|--|------|
| PA20 | *TDS | <p>Tough drive setting</p> <p>Alarms may not be avoided with the tough drive function depending on the situations of the power supply and load fluctuation.</p> <p>You can assign MTTR (During tough drive) to pins CN3-11 to CN3-13, CN3-24, and CN3-25 with [Pr. PD07] to [Pr. PD09]. For MR-J4W2-0303B6 servo amplifiers, MTTR (during tough drive) cannot be assigned.</p> <table border="1"> <thead> <tr> <th>Setting digit</th> <th>Explanation</th> <th>Initial value</th> </tr> </thead> <tbody> <tr> <td>___x</td> <td>For manufacturer setting</td> <td>0h</td> </tr> <tr> <td>__x_</td> <td>Vibration tough drive selection 0: Disabled 1: Enabled Selecting "1" enables to suppress vibrations by automatically changing setting values of [Pr. PB13 Machine resonance suppression filter 1] and [Pr. PB15 Machine resonance suppression filter 2] in case that the vibration exceed the value of the oscillation level set in [Pr. PF23]. Refer to section 7.3 for details.</td> <td>0h</td> </tr> <tr> <td>_x__</td> <td>SEMI-F47 function selection 0: Disabled 1: Enabled Selecting "1" enables to avoid generating [AL. 10 Undervoltage] using the electrical energy charged in the capacitor in case that an instantaneous power failure occurs during operation. Set the time of until [AL. 10.1 Voltage drop in the control circuit power] occurs in [Pr. PF25 SEMI-F47 function - Instantaneous power failure detection time]. A specified axis cannot be enabled for the instantaneous power failure tough drive function. For MR-J4W2-0303B6 servo amplifiers, this digit cannot be used other than the initial value.</td> <td>0h</td> </tr> <tr> <td>x___</td> <td>For manufacturer setting</td> <td>0h</td> </tr> </tbody> </table> | Setting digit | Explanation | Initial value | ___x | For manufacturer setting | 0h | __x_ | Vibration tough drive selection 0: Disabled 1: Enabled Selecting "1" enables to suppress vibrations by automatically changing setting values of [Pr. PB13 Machine resonance suppression filter 1] and [Pr. PB15 Machine resonance suppression filter 2] in case that the vibration exceed the value of the oscillation level set in [Pr. PF23]. Refer to section 7.3 for details. | 0h | _x__ | SEMI-F47 function selection 0: Disabled 1: Enabled Selecting "1" enables to avoid generating [AL. 10 Undervoltage] using the electrical energy charged in the capacitor in case that an instantaneous power failure occurs during operation. Set the time of until [AL. 10.1 Voltage drop in the control circuit power] occurs in [Pr. PF25 SEMI-F47 function - Instantaneous power failure detection time]. A specified axis cannot be enabled for the instantaneous power failure tough drive function. For MR-J4W2-0303B6 servo amplifiers, this digit cannot be used other than the initial value. | 0h | x___ | For manufacturer setting | 0h | Refer to Name and function column. | | Each |
| Setting digit | Explanation | Initial value | | | | | | | | | | | | | | | | | | |
| ___x | For manufacturer setting | 0h | | | | | | | | | | | | | | | | | | |
| __x_ | Vibration tough drive selection 0: Disabled 1: Enabled Selecting "1" enables to suppress vibrations by automatically changing setting values of [Pr. PB13 Machine resonance suppression filter 1] and [Pr. PB15 Machine resonance suppression filter 2] in case that the vibration exceed the value of the oscillation level set in [Pr. PF23]. Refer to section 7.3 for details. | 0h | | | | | | | | | | | | | | | | | | |
| _x__ | SEMI-F47 function selection 0: Disabled 1: Enabled Selecting "1" enables to avoid generating [AL. 10 Undervoltage] using the electrical energy charged in the capacitor in case that an instantaneous power failure occurs during operation. Set the time of until [AL. 10.1 Voltage drop in the control circuit power] occurs in [Pr. PF25 SEMI-F47 function - Instantaneous power failure detection time]. A specified axis cannot be enabled for the instantaneous power failure tough drive function. For MR-J4W2-0303B6 servo amplifiers, this digit cannot be used other than the initial value. | 0h | | | | | | | | | | | | | | | | | | |
| x___ | For manufacturer setting | 0h | | | | | | | | | | | | | | | | | | |
| PA21 | *AOP3 | <p>Function selection A-3</p> <table border="1"> <thead> <tr> <th>Setting digit</th> <th>Explanation</th> <th>Initial value</th> </tr> </thead> <tbody> <tr> <td>___x</td> <td>One-touch tuning function selection 0: Disabled 1: Enabled When the digit is "0", the one-touch tuning with MR Configurator2 will be disabled.</td> <td>1h</td> </tr> <tr> <td>__x_</td> <td rowspan="3">For manufacturer setting</td> <td>0h</td> </tr> <tr> <td>_x__</td> <td>0h</td> </tr> <tr> <td>x___</td> <td>0h</td> </tr> </tbody> </table> | Setting digit | Explanation | Initial value | ___x | One-touch tuning function selection 0: Disabled 1: Enabled When the digit is "0", the one-touch tuning with MR Configurator2 will be disabled. | 1h | __x_ | For manufacturer setting | 0h | _x__ | 0h | x___ | 0h | Refer to Name and function column. | | Each | | |
| Setting digit | Explanation | Initial value | | | | | | | | | | | | | | | | | | |
| ___x | One-touch tuning function selection 0: Disabled 1: Enabled When the digit is "0", the one-touch tuning with MR Configurator2 will be disabled. | 1h | | | | | | | | | | | | | | | | | | |
| __x_ | For manufacturer setting | 0h | | | | | | | | | | | | | | | | | | |
| _x__ | | 0h | | | | | | | | | | | | | | | | | | |
| x___ | | 0h | | | | | | | | | | | | | | | | | | |

5. PARAMETERS

| No. | Symbol | Name and function | Initial value [unit] | Setting range | Each/ Common | | | | | | | | | | | | | |
|---------------|---------------------------------------------------------------------------------------------------------------------------------------------------------------------------------------------------------------------------------------------------------------------------------------------------------------------------------------------------------------------------------------------------------------------------------------------------------------------------------------------------------------------------------------------------------------------------------------------------------------------------------------------------------------------------|---------------------------------------------------------------------------------------------------------------------------------------------------------------------------------------------------------------------------------------------------------------------------------------------------------------------------------------------------------------------------------------------------------------------------------------------------------------------------------------------------------------------------------------------------------------------------------------------------------------------------------------------------------------------------------------------------------------------------------------------------------------------------------------------------------------------------------------------------------------------------------------------------------------------------------------------------------------------------------------------------------------------------------------------------------------------------------------------------------------------------------------------------------------------------------------------|----------------------|---------------|---------------|--------|-----------------------------------------------------------------------------------------------------------------------------------------------------------------------------------------------------------------------------------------------------------|-----|--------|-------------------------------------------------------------------------------------------------------------------------------------------------------------------------------------------------------------------|------|------------------------------------|------|---------------------------------------------------------------------------------------------------------------------------------------------------------------------------------------------------------------------------------------------------------------------------------------------------------------------------------------------------------------------------------------------------------------------------------------------------------------------------------------------------------------------------------------------------------------------------------------------------------------------------------------------------------------------------|----|------------------------------------|--|------|
| PA22 | **PCS | Position control composition selection <table border="1" style="width: 100%; border-collapse: collapse;"> <thead> <tr> <th style="width: 15%;">Setting digit</th> <th style="width: 65%;">Explanation</th> <th style="width: 20%;">Initial value</th> </tr> </thead> <tbody> <tr> <td>___x</td> <td rowspan="3">For manufacturer setting</td> <td>0h</td> </tr> <tr> <td>__x_</td> <td>0h</td> </tr> <tr> <td>_x__</td> <td>0h</td> </tr> <tr> <td>x___</td> <td>Scale measurement function selection 0: Disabled 1: Used in absolute position detection system 2: Used in incremental system The setting of this digit is enabled with software version A8 or later. The absolute position detection system cannot be used while an incremental type encoder is used. Enabling absolute position detection system will trigger [AL. 37 Parameter error]. Additionally, the setting is enabled only in the standard control mode. Setting other than "0" in other operation modes triggers [AL. 37 Parameter error]. For MR-J4W2-0303B6 servo amplifiers, this digit cannot be used other than the initial value.</td> <td>0h</td> </tr> </tbody> </table> | Setting digit | Explanation | Initial value | ___x | For manufacturer setting | 0h | __x_ | 0h | _x__ | 0h | x___ | Scale measurement function selection 0: Disabled 1: Used in absolute position detection system 2: Used in incremental system The setting of this digit is enabled with software version A8 or later. The absolute position detection system cannot be used while an incremental type encoder is used. Enabling absolute position detection system will trigger [AL. 37 Parameter error]. Additionally, the setting is enabled only in the standard control mode. Setting other than "0" in other operation modes triggers [AL. 37 Parameter error]. For MR-J4W2-0303B6 servo amplifiers, this digit cannot be used other than the initial value. | 0h | Refer to Name and function column. | | Each |
| Setting digit | Explanation | Initial value | | | | | | | | | | | | | | | | |
| ___x | For manufacturer setting | 0h | | | | | | | | | | | | | | | | |
| __x_ | | 0h | | | | | | | | | | | | | | | | |
| _x__ | | 0h | | | | | | | | | | | | | | | | |
| x___ | Scale measurement function selection 0: Disabled 1: Used in absolute position detection system 2: Used in incremental system The setting of this digit is enabled with software version A8 or later. The absolute position detection system cannot be used while an incremental type encoder is used. Enabling absolute position detection system will trigger [AL. 37 Parameter error]. Additionally, the setting is enabled only in the standard control mode. Setting other than "0" in other operation modes triggers [AL. 37 Parameter error]. For MR-J4W2-0303B6 servo amplifiers, this digit cannot be used other than the initial value. | 0h | | | | | | | | | | | | | | | | |
| PA23 | DRAT | Drive recorder arbitrary alarm trigger setting <table border="1" style="width: 100%; border-collapse: collapse;"> <thead> <tr> <th style="width: 15%;">Setting digit</th> <th style="width: 65%;">Explanation</th> <th style="width: 20%;">Initial value</th> </tr> </thead> <tbody> <tr> <td>__ x x</td> <td>Alarm detail No. setting Set the digits when you execute the trigger with arbitrary alarm detail No. for the drive recorder function. When these digits are "0 0", the drive recorder will operate with any alarm No. regardless of detail numbers.</td> <td>00h</td> </tr> <tr> <td>x x __</td> <td>Alarm No. setting Set the digits when you execute the trigger with arbitrary alarm No. for the drive recorder function. When "0 0" are set, arbitrary alarm trigger of the drive recorder will be disabled.</td> <td>00h</td> </tr> </tbody> </table> <p>Setting example: To activate the drive recorder when [AL. 50 Overload 1] occurs, set "5 0 0 0". To activate the drive recorder when [AL. 50.3 Thermal overload error 4 during operation] occurs, set "5 0 0 3".</p> | Setting digit | Explanation | Initial value | __ x x | Alarm detail No. setting Set the digits when you execute the trigger with arbitrary alarm detail No. for the drive recorder function. When these digits are "0 0", the drive recorder will operate with any alarm No. regardless of detail numbers. | 00h | x x __ | Alarm No. setting Set the digits when you execute the trigger with arbitrary alarm No. for the drive recorder function. When "0 0" are set, arbitrary alarm trigger of the drive recorder will be disabled. | 00h | Refer to Name and function column. | | Common | | | | |
| Setting digit | Explanation | Initial value | | | | | | | | | | | | | | | | |
| __ x x | Alarm detail No. setting Set the digits when you execute the trigger with arbitrary alarm detail No. for the drive recorder function. When these digits are "0 0", the drive recorder will operate with any alarm No. regardless of detail numbers. | 00h | | | | | | | | | | | | | | | | |
| x x __ | Alarm No. setting Set the digits when you execute the trigger with arbitrary alarm No. for the drive recorder function. When "0 0" are set, arbitrary alarm trigger of the drive recorder will be disabled. | 00h | | | | | | | | | | | | | | | | |

5. PARAMETERS

| No. | Symbol | Name and function | Initial value [unit] | Setting range | Each/ Common | | | | | | | | | | | | | |
|------|--------------------------|--------------------------------------------------------------------------------------------------------------------------------------------------------------------------------------------------------------------------------------------------------------------------------------------------------------------------------------------------------------------------------------------------------------------------------------------------------------------------------------------------------------------------------------------------------------------------------------------------------------------------------------------------------------------------------------------------------------------------------------------------------------------------------------------------------------------------------------------------------------------------------------------------------------------------------------------------------------------------------------------------------------|------------------------------------|---------------|--------------|------------------------------------------------------------------------------------------------------------------------------------------------------------------------------------------------------------------------------------------------------------------------------------------------------------------------------------------------------------------------------------------------------------------------------------------------------------------------------------------------------------------------------------------------------------------------------------------------------------------------------------------------|---------------|---------------|------|------------------------------------------------------------------------------------------------------------------------------------------------------------------------------------------------------------------------------------------------------------------------------------------------------------------------------------------------------------------------------------------------------------------------------------------------------------------------------------------------------------------------------------------------------------------------------------------------------------------------------------------------|----|------|--------------------------|----|------|----|------|----|
| PA24 | AOP4 | Function selection A-4 | Refer to Name and function column. | | Each | | | | | | | | | | | | | |
| | | <table border="1"> <thead> <tr> <th>Setting digit</th> <th>Explanation</th> <th>Initial value</th> </tr> </thead> <tbody> <tr> <td>___x</td> <td>Vibration suppression mode selection 0: Standard mode 1: 3 inertia mode 2: Low response mode When two low resonance frequencies are generated, select "3 inertia mode (___ 1)". When the load to motor inertia ratio exceeds the recommended load to motor inertia ratio select "Low response mode (___ 2)". When you select the standard mode or low response mode, "Vibration suppression control 2" is not available. When you select the 3 inertia mode, the feed forward gain is not available. Before changing the control mode with the controller during the 3 inertia mode or low response mode, stop the motor.</td> <td>0h</td> </tr> <tr> <td>__x_</td> <td rowspan="3">For manufacturer setting</td> <td>0h</td> </tr> <tr> <td>_x__</td> <td>0h</td> </tr> <tr> <td>x___</td> <td>0h</td> </tr> </tbody> </table> | | | | Setting digit | Explanation | Initial value | ___x | Vibration suppression mode selection 0: Standard mode 1: 3 inertia mode 2: Low response mode When two low resonance frequencies are generated, select "3 inertia mode (___ 1)". When the load to motor inertia ratio exceeds the recommended load to motor inertia ratio select "Low response mode (___ 2)". When you select the standard mode or low response mode, "Vibration suppression control 2" is not available. When you select the 3 inertia mode, the feed forward gain is not available. Before changing the control mode with the controller during the 3 inertia mode or low response mode, stop the motor. | 0h | __x_ | For manufacturer setting | 0h | _x__ | 0h | x___ | 0h |
| | | Setting digit | | | | Explanation | Initial value | | | | | | | | | | | |
| | | ___x | | | | Vibration suppression mode selection 0: Standard mode 1: 3 inertia mode 2: Low response mode When two low resonance frequencies are generated, select "3 inertia mode (___ 1)". When the load to motor inertia ratio exceeds the recommended load to motor inertia ratio select "Low response mode (___ 2)". When you select the standard mode or low response mode, "Vibration suppression control 2" is not available. When you select the 3 inertia mode, the feed forward gain is not available. Before changing the control mode with the controller during the 3 inertia mode or low response mode, stop the motor. | 0h | | | | | | | | | | | |
| __x_ | For manufacturer setting | 0h | | | | | | | | | | | | | | | | |
| _x__ | | 0h | | | | | | | | | | | | | | | | |
| x___ | | 0h | | | | | | | | | | | | | | | | |
| | | | | | | | | | | | | | | | | | | |
| | | | | | | | | | | | | | | | | | | |
| PA25 | OTHOV | One-touch tuning - Overshoot permissible level Set a permissible value of overshoot amount for one-touch tuning as a percentage of the in-position range. However, setting "0" will be 50%. | 0 [%] | 0 to 100 | Each | | | | | | | | | | | | | |

5. PARAMETERS

5.2.2 Gain/filter setting parameters ([Pr. PB_ _])

| No. | Symbol | Name and function | Initial value [unit] | Setting range | Each/ Common | | | | | | | | | | | | | | |
|------|---------------------------------------------------------------------------------------------------------------------------------------------------------------------------------------------------------------------------------------------------------------------------------------------------------------------------|------------------------------------------------------------------------------------------------------------------------------------------------------------------------------------------------------------------------------------------------------------------------------------------------------------------------------------------------------------------|------------------------------------|---------------|-------------------------------------------------------------------------------------------------------------------------------------------------------------------------------------------------------------------------------------------------------------------------------------------------------------------------------------------------------------------------------------------------------------------------------------------------------------------------------------------------------------------------------------------------------------------------------------------------------------------------------------------------------------------------------------------------------------------------------------------------------------------------------------------------------------------------------------------------------------------------------------------------------------|---------------|-------------|---------------|------|-----------------------------------------------------------------------------------------------------------------------------------------------------------------------------------------------------------|----|------|-------------------------------------------------------------------------------------------------------------------------------------------------------------------------------------------------------------------------------------------------------------------------------------------------------------------------|----|------|--------------------------|------|---------------------------------------------------------------------------------------------------------------------------------------------------------------------------------------------------------------------------------------------------------------------------------------------------------------------------|----|
| PB01 | FILT | Adaptive tuning mode (adaptive filter II) Set the adaptive tuning. All axes cannot be simultaneously enabled for this function. Set for each axis to use. | Refer to Name and function column. | Each | <table border="1"> <thead> <tr> <th>Setting digit</th> <th>Explanation</th> <th>Initial value</th> </tr> </thead> <tbody> <tr> <td>___x</td> <td>Filter tuning mode selection Select the adjustment mode of the machine resonance suppression filter 1. Refer to section 7.1.2 for details. 0: Disabled 1: Automatic setting 2: Manual setting</td> <td>0h</td> </tr> <tr> <td>__x_</td> <td rowspan="2">For manufacturer setting</td> <td>0h</td> </tr> <tr> <td>_x__</td> <td>0h</td> </tr> <tr> <td>x___</td> <td>Tuning accuracy selection 0: Standard 1: High accuracy The frequency is estimated more accurately in the high accuracy mode compared to the standard mode. However, the tuning sound may be larger in the high accuracy mode. This digit is available with servo amplifier with software version C5 or later.</td> <td>0h</td> </tr> </tbody> </table> | Setting digit | Explanation | Initial value | ___x | Filter tuning mode selection Select the adjustment mode of the machine resonance suppression filter 1. Refer to section 7.1.2 for details. 0: Disabled 1: Automatic setting 2: Manual setting | 0h | __x_ | For manufacturer setting | 0h | _x__ | 0h | x___ | Tuning accuracy selection 0: Standard 1: High accuracy The frequency is estimated more accurately in the high accuracy mode compared to the standard mode. However, the tuning sound may be larger in the high accuracy mode. This digit is available with servo amplifier with software version C5 or later. | 0h |
| | | Setting digit | | | Explanation | Initial value | | | | | | | | | | | | | |
| | | ___x | | | Filter tuning mode selection Select the adjustment mode of the machine resonance suppression filter 1. Refer to section 7.1.2 for details. 0: Disabled 1: Automatic setting 2: Manual setting | 0h | | | | | | | | | | | | | |
| | | __x_ | | | For manufacturer setting | 0h | | | | | | | | | | | | | |
| | | _x__ | | | | 0h | | | | | | | | | | | | | |
| x___ | Tuning accuracy selection 0: Standard 1: High accuracy The frequency is estimated more accurately in the high accuracy mode compared to the standard mode. However, the tuning sound may be larger in the high accuracy mode. This digit is available with servo amplifier with software version C5 or later. | 0h | | | | | | | | | | | | | | | | | |
| PB02 | VRFT | Vibration suppression control tuning mode (advanced vibration suppression control II) This is used to set the vibration suppression control tuning. Refer to section 7.1.5 for details. All axes cannot be simultaneously enabled for this function. Set for each axis to use. | Refer to Name and function column. | Each | <table border="1"> <thead> <tr> <th>Setting digit</th> <th>Explanation</th> <th>Initial value</th> </tr> </thead> <tbody> <tr> <td>___x</td> <td>Vibration suppression control 1 tuning mode selection Select the tuning mode of the vibration suppression control 1. 0: Disabled 1: Automatic setting 2: Manual setting</td> <td>0h</td> </tr> <tr> <td>__x_</td> <td>Vibration suppression control 2 tuning mode selection Select the tuning mode of the vibration suppression control 2. To enable the digit, select "3 inertia mode (___1)" of "Vibration suppression mode selection" in [Pr. PA24 Function selection A-4]. 0: Disabled 1: Automatic setting 2: Manual setting</td> <td>0h</td> </tr> <tr> <td>_x__</td> <td rowspan="2">For manufacturer setting</td> <td>0h</td> </tr> <tr> <td>x___</td> <td>0h</td> </tr> </tbody> </table> | Setting digit | Explanation | Initial value | ___x | Vibration suppression control 1 tuning mode selection Select the tuning mode of the vibration suppression control 1. 0: Disabled 1: Automatic setting 2: Manual setting | 0h | __x_ | Vibration suppression control 2 tuning mode selection Select the tuning mode of the vibration suppression control 2. To enable the digit, select "3 inertia mode (___1)" of "Vibration suppression mode selection" in [Pr. PA24 Function selection A-4]. 0: Disabled 1: Automatic setting 2: Manual setting | 0h | _x__ | For manufacturer setting | 0h | x___ | 0h |
| | | Setting digit | | | Explanation | Initial value | | | | | | | | | | | | | |
| | | ___x | | | Vibration suppression control 1 tuning mode selection Select the tuning mode of the vibration suppression control 1. 0: Disabled 1: Automatic setting 2: Manual setting | 0h | | | | | | | | | | | | | |
| | | __x_ | | | Vibration suppression control 2 tuning mode selection Select the tuning mode of the vibration suppression control 2. To enable the digit, select "3 inertia mode (___1)" of "Vibration suppression mode selection" in [Pr. PA24 Function selection A-4]. 0: Disabled 1: Automatic setting 2: Manual setting | 0h | | | | | | | | | | | | | |
| | | _x__ | | | For manufacturer setting | 0h | | | | | | | | | | | | | |
| x___ | 0h | | | | | | | | | | | | | | | | | | |
| PB03 | TFBGN | Torque feedback loop gain Set a torque feedback loop gain in the continuous operation to torque control mode. Decreasing the setting value will also decrease a collision load during continuous operation to torque control mode. Setting a value less than 6 rad/s will be 6 rad/s. | 18000 [rad/s] | 0 to 18000 | Each | | | | | | | | | | | | | | |
| PB04 | FFC | Feed forward gain Set the feed forward gain. When the setting is 100%, the droop pulses during operation at constant speed are nearly zero. However, sudden acceleration/deceleration will increase the overshoot. As a guideline, when the feed forward gain setting is 100%, set 1 s or more as the acceleration time constant up to the rated speed. | 0 [%] | 0 to 100 | Each | | | | | | | | | | | | | | |

5. PARAMETERS

| No. | Symbol | Name and function | Initial value [unit] | Setting range | Each/ Common | | | | | | | | | | |
|-------------------------------------------------------|-------------------|-------------------------------------------------------------------------------------------------------------------------------------------------------------------------------------------------------------------------------------------------------------------------------------------------------------------------------------------------------------------------------------------------------------------------------------------------------------------------------------------------------------------------------------------------------------------------------------------------------------------------------------------------------------------------------------------------------------------------------------------------------------------------------------------------------------------------------------------------------------------------------------------------------------------------------------------------------------------------------------------------------------------------------------------------------------------------------------------------|----------------------|----------------|-------------------------------------------------------|-------------------|----------------------------|----------------------------|----------------------------|---------------------|----------------------------------|----------------------------------|-----------------|---------------|------|
| PB06 | GD2 | <p>Load to motor inertia ratio/load to motor mass ratio</p> <p>Set a load to motor inertia ratio or load to motor mass ratio. Setting a value considerably different from the actual load moment of inertia or load mass may cause an unexpected operation such as an overshoot.</p> <p>The setting of the parameter will be the automatic setting or manual setting depending on the [Pr. PA08] setting. Refer to the following table for details. When the parameter is automatic setting, the value will vary between 0.00 and 100.00.</p> <table border="1" style="margin-left: auto; margin-right: auto;"> <thead> <tr> <th>Pr. PA08</th> <th>This parameter</th> </tr> </thead> <tbody> <tr> <td>___ 0 (2 gain adjustment mode 1 (interpolation mode))</td> <td rowspan="2">Automatic setting</td> </tr> <tr> <td>___ 1 (Auto tuning mode 1)</td> </tr> <tr> <td>___ 2 (Auto tuning mode 2)</td> <td rowspan="3">Manual setting</td> </tr> <tr> <td>___ 3 (Manual mode)</td> </tr> <tr> <td>___ 4 (2 gain adjustment mode 2)</td> </tr> </tbody> </table> | Pr. PA08 | This parameter | ___ 0 (2 gain adjustment mode 1 (interpolation mode)) | Automatic setting | ___ 1 (Auto tuning mode 1) | ___ 2 (Auto tuning mode 2) | Manual setting | ___ 3 (Manual mode) | ___ 4 (2 gain adjustment mode 2) | 7.00 [Multiplier] | 0.00 to 300.00 | Each | |
| Pr. PA08 | This parameter | | | | | | | | | | | | | | |
| ___ 0 (2 gain adjustment mode 1 (interpolation mode)) | Automatic setting | | | | | | | | | | | | | | |
| ___ 1 (Auto tuning mode 1) | | | | | | | | | | | | | | | |
| ___ 2 (Auto tuning mode 2) | Manual setting | | | | | | | | | | | | | | |
| ___ 3 (Manual mode) | | | | | | | | | | | | | | | |
| ___ 4 (2 gain adjustment mode 2) | | | | | | | | | | | | | | | |
| PB07 | PG1 | <p>Model loop gain</p> <p>Set the response gain up to the target position.</p> <p>Increasing the setting value will also increase the response level to the position command but will be liable to generate vibration and noise.</p> <p>For the vibration suppression control tuning mode, the setting range of [Pr. PB07] is limited. Refer to section 7.1.5 (4) for details.</p> <p>The setting of the parameter will be the automatic setting or manual setting depending on the [Pr. PA08] setting. Refer to the following table for details.</p> <table border="1" style="margin-left: auto; margin-right: auto;"> <thead> <tr> <th>Pr. PA08</th> <th>This parameter</th> </tr> </thead> <tbody> <tr> <td>___ 0 (2 gain adjustment mode 1 (interpolation mode))</td> <td>Manual setting</td> </tr> <tr> <td>___ 1 (Auto tuning mode 1)</td> <td rowspan="2">Automatic setting</td> </tr> <tr> <td>___ 2 (Auto tuning mode 2)</td> </tr> <tr> <td>___ 3 (Manual mode)</td> <td rowspan="2">Manual setting</td> </tr> <tr> <td>___ 4 (2 gain adjustment mode 2)</td> </tr> </tbody> </table> | Pr. PA08 | This parameter | ___ 0 (2 gain adjustment mode 1 (interpolation mode)) | Manual setting | ___ 1 (Auto tuning mode 1) | Automatic setting | ___ 2 (Auto tuning mode 2) | ___ 3 (Manual mode) | Manual setting | ___ 4 (2 gain adjustment mode 2) | 15.0 [rad/s] | 1.0 to 2000.0 | Each |
| Pr. PA08 | This parameter | | | | | | | | | | | | | | |
| ___ 0 (2 gain adjustment mode 1 (interpolation mode)) | Manual setting | | | | | | | | | | | | | | |
| ___ 1 (Auto tuning mode 1) | Automatic setting | | | | | | | | | | | | | | |
| ___ 2 (Auto tuning mode 2) | | | | | | | | | | | | | | | |
| ___ 3 (Manual mode) | Manual setting | | | | | | | | | | | | | | |
| ___ 4 (2 gain adjustment mode 2) | | | | | | | | | | | | | | | |
| PB08 | PG2 | <p>Position loop gain</p> <p>Set a gain of the position loop.</p> <p>Set this parameter to increase the position response to level load disturbance.</p> <p>Increasing the setting value will also increase the response level to the load disturbance but will be liable to generate vibration and noise.</p> <p>The setting of the parameter will be the automatic setting or manual setting depending on the [Pr. PA08] setting. Refer to the following table for details.</p> <table border="1" style="margin-left: auto; margin-right: auto;"> <thead> <tr> <th>Pr. PA08</th> <th>This parameter</th> </tr> </thead> <tbody> <tr> <td>___ 0 (2 gain adjustment mode 1 (interpolation mode))</td> <td rowspan="3">Automatic setting</td> </tr> <tr> <td>___ 1 (Auto tuning mode 1)</td> </tr> <tr> <td>___ 2 (Auto tuning mode 2)</td> </tr> <tr> <td>___ 3 (Manual mode)</td> <td>Manual setting</td> </tr> <tr> <td>___ 4 (2 gain adjustment mode 2)</td> <td>Automatic setting</td> </tr> </tbody> </table> | Pr. PA08 | This parameter | ___ 0 (2 gain adjustment mode 1 (interpolation mode)) | Automatic setting | ___ 1 (Auto tuning mode 1) | ___ 2 (Auto tuning mode 2) | ___ 3 (Manual mode) | Manual setting | ___ 4 (2 gain adjustment mode 2) | Automatic setting | 37.0 [rad/s] | 1.0 to 2000.0 | Each |
| Pr. PA08 | This parameter | | | | | | | | | | | | | | |
| ___ 0 (2 gain adjustment mode 1 (interpolation mode)) | Automatic setting | | | | | | | | | | | | | | |
| ___ 1 (Auto tuning mode 1) | | | | | | | | | | | | | | | |
| ___ 2 (Auto tuning mode 2) | | | | | | | | | | | | | | | |
| ___ 3 (Manual mode) | Manual setting | | | | | | | | | | | | | | |
| ___ 4 (2 gain adjustment mode 2) | Automatic setting | | | | | | | | | | | | | | |
| PB09 | VG2 | <p>Speed loop gain</p> <p>Set a gain of the speed loop.</p> <p>Set this parameter when vibration occurs on machines of low rigidity or large backlash. Increasing the setting value will also increase the response level but will be liable to generate vibration and noise.</p> <p>The setting of the parameter will be the automatic setting or manual setting depending on the [Pr. PA08] setting. Refer to the table of [Pr. PB08] for details.</p> | 823 [rad/s] | 20 to 65535 | Each | | | | | | | | | | |

5. PARAMETERS

| No. | Symbol | Name and function | Initial value [unit] | Setting range | Each/ Common | | | | | | | | | | | | | | | |
|---------------|---------------------------------------------------------------------------------------------------|---------------------------------------------------------------------------------------------------------------------------------------------------------------------------------------------------------------------------------------------------------------------------------------------------------------------------------------------------------------------------------------------------------------------------------------------------------------------------------------------------------------------------------------------------------------------------------------------------------------------------------|------------------------------------|---------------|---------------|---------|--------------------------|----|---------|-------------------------------------------------------------------------|----|---------|---------------------------------------------------------------------------------------------------|----|---------|--------------------------|----|--|--|--|
| PB10 | VIC | Speed integral compensation Set an integral time constant of the speed loop. Decreasing the setting value will increase the response level but will be liable to generate vibration and noise. The setting of the parameter will be the automatic setting or manual setting depending on the [Pr. PA08] setting. Refer to the table of [Pr. PB08] for details. | 33.7 [ms] | 0.1 to 1000.0 | Each | | | | | | | | | | | | | | | |
| PB11 | VDC | Speed differential compensation Set a differential compensation. To enable the parameter, select "Continuous PID control enabled (_ _ 3 _)" of "PI-PID switching control selection" in [Pr. PB24]. | 980 | 0 to 1000 | Each | | | | | | | | | | | | | | | |
| PB12 | OVA | Overshoot amount compensation Set a viscous friction torque in percentage to the rated torque at servo motor rated speed. Or, set a percentage of viscous friction force against the continuous thrust at linear servo motor rated speed. When the response level is low or when the torque/thrust is limited, the efficiency of the parameter may be lower. | 0 [%] | 0 to 100 | Each | | | | | | | | | | | | | | | |
| PB13 | NH1 | Machine resonance suppression filter 1 Set the notch frequency of the machine resonance suppression filter 1. When "Filter tuning mode selection" is set to "Automatic setting (_ _ _ 1)" in [Pr. PB01], this parameter will be adjusted automatically by adaptive tuning. When "Filter tuning mode selection" is set to "Manual setting (_ _ _ 2)" in [Pr. PB01], the setting value will be enabled. | 4500 [Hz] | 10 to 4500 | Each | | | | | | | | | | | | | | | |
| PB14 | NHQ1 | Notch shape selection 1 Set the shape of the machine resonance suppression filter 1. When "Filter tuning mode selection" is set to "Automatic setting (_ _ _ 1)" in [Pr. PB01], this parameter will be adjusted automatically by adaptive tuning. To enable the setting value, select the manual setting. | Refer to Name and function column. | | Each | | | | | | | | | | | | | | | |
| | | <table border="1"> <thead> <tr> <th>Setting digit</th> <th>Explanation</th> <th>Initial value</th> </tr> </thead> <tbody> <tr> <td>_ _ _ x</td> <td>For manufacturer setting</td> <td>0h</td> </tr> <tr> <td>_ _ x _</td> <td>Notch depth selection 0: -40 dB 1: -14 dB 2: -8 dB 3: -4 dB</td> <td>0h</td> </tr> <tr> <td>_ x _ _</td> <td>Notch width selection 0: $\alpha = 2$ 1: $\alpha = 3$ 2: $\alpha = 4$ 3: $\alpha = 5$</td> <td>0h</td> </tr> <tr> <td>x _ _ _</td> <td>For manufacturer setting</td> <td>0h</td> </tr> </tbody> </table> | Setting digit | Explanation | Initial value | _ _ _ x | For manufacturer setting | 0h | _ _ x _ | Notch depth selection 0: -40 dB 1: -14 dB 2: -8 dB 3: -4 dB | 0h | _ x _ _ | Notch width selection 0: $\alpha = 2$ 1: $\alpha = 3$ 2: $\alpha = 4$ 3: $\alpha = 5$ | 0h | x _ _ _ | For manufacturer setting | 0h | | | |
| Setting digit | Explanation | Initial value | | | | | | | | | | | | | | | | | | |
| _ _ _ x | For manufacturer setting | 0h | | | | | | | | | | | | | | | | | | |
| _ _ x _ | Notch depth selection 0: -40 dB 1: -14 dB 2: -8 dB 3: -4 dB | 0h | | | | | | | | | | | | | | | | | | |
| _ x _ _ | Notch width selection 0: $\alpha = 2$ 1: $\alpha = 3$ 2: $\alpha = 4$ 3: $\alpha = 5$ | 0h | | | | | | | | | | | | | | | | | | |
| x _ _ _ | For manufacturer setting | 0h | | | | | | | | | | | | | | | | | | |
| PB15 | NH2 | Machine resonance suppression filter 2 Set the notch frequency of the machine resonance suppression filter 2. To enable the setting value, select "Enabled (_ _ _ 1)" of "Machine resonance suppression filter 2 selection" in [Pr. PB16]. | 4500 [Hz] | 10 to 4500 | Each | | | | | | | | | | | | | | | |

5. PARAMETERS

| No. | Symbol | Name and function | Initial value [unit] | Setting range | Each/ Common | | | | | | | | | | | | | | | |
|---------------|---------------------------------------------------------------------------------------------------|----------------------------------------------------------------------------------------------------------------------------------------------------------------------------------------------------------------------------------------------------------------------------------------------------------------------------------------------------------------------------------------------------------------------------------------------------------------------------------------------------------------------------------------------------------------------------------------------------------------------------------------------------------------------------|------------------------------------|---------------|---------------|------|-------------------------------------------------------------------------------|----|------|-------------------------------------------------------------------------|----|------|---------------------------------------------------------------------------------------------------|----|------|--------------------------|----|--|--|--|
| PB16 | NHQ2 | Notch shape selection 2 Set the shape of the machine resonance suppression filter 2. | Refer to Name and function column. | | Each | | | | | | | | | | | | | | | |
| | | <table border="1"> <thead> <tr> <th>Setting digit</th> <th>Explanation</th> <th>Initial value</th> </tr> </thead> <tbody> <tr> <td>___x</td> <td>Machine resonance suppression filter 2 selection 0: Disabled 1: Enabled</td> <td>0h</td> </tr> <tr> <td>__x_</td> <td>Notch depth selection 0: -40 dB 1: -14 dB 2: -8 dB 3: -4 dB</td> <td>0h</td> </tr> <tr> <td>_x__</td> <td>Notch width selection 0: $\alpha = 2$ 1: $\alpha = 3$ 2: $\alpha = 4$ 3: $\alpha = 5$</td> <td>0h</td> </tr> <tr> <td>x___</td> <td>For manufacturer setting</td> <td>0h</td> </tr> </tbody> </table> | Setting digit | Explanation | Initial value | ___x | Machine resonance suppression filter 2 selection 0: Disabled 1: Enabled | 0h | __x_ | Notch depth selection 0: -40 dB 1: -14 dB 2: -8 dB 3: -4 dB | 0h | _x__ | Notch width selection 0: $\alpha = 2$ 1: $\alpha = 3$ 2: $\alpha = 4$ 3: $\alpha = 5$ | 0h | x___ | For manufacturer setting | 0h | | | |
| Setting digit | Explanation | Initial value | | | | | | | | | | | | | | | | | | |
| ___x | Machine resonance suppression filter 2 selection 0: Disabled 1: Enabled | 0h | | | | | | | | | | | | | | | | | | |
| __x_ | Notch depth selection 0: -40 dB 1: -14 dB 2: -8 dB 3: -4 dB | 0h | | | | | | | | | | | | | | | | | | |
| _x__ | Notch width selection 0: $\alpha = 2$ 1: $\alpha = 3$ 2: $\alpha = 4$ 3: $\alpha = 5$ | 0h | | | | | | | | | | | | | | | | | | |
| x___ | For manufacturer setting | 0h | | | | | | | | | | | | | | | | | | |

5. PARAMETERS

| No. | Symbol | Name and function | Initial value [unit] | Setting range | Each/ Common | | | | | | | | | | | | | | | | | | | | | | | | | | | | | | | | | | | | | | | | | | | | | | | | | | | | | | | | | | | | | | | | | | | | | | | | | | | | | | | | |
|---------------|----------------------------------------------------------------------------------------------------------------------------------------------------------------------------------------------------------------------------|--------------------------------------------------------------------------------------------------------------------------------------------------------------------------------------------------------------------------------------------------------------------------------------------------------------------------------------------------------------------------------------------------------------------------------------------------------------------------------------------------------------------------------------------------------------------------------------------------------------------------------------------------------------------------------------------------------------------------------------------------------------------------------------------------------------------------------------------------------------------------------------------------------------------------------------------------------------------------------------------------------------------------------------------------------------------------------------------------------------------------------------------------------------------------------------------------------------------------------------------------------------------------------------------------------------------------------------------------------------------------------------------------------------------------------------------------------------------------------------------------------------------------------------------------------------------------------------------------------------------------------------------------------------------------------------------------------------------------------------------------------------------------------------------------------------------------------------------------------------------------------------------------------------------------------------------------------------------------------------------------------------------------------------------------------------------------------------------------------------------------------------------------------------------------------------------------------------------------------------------------------------------------------------------------------------------------------------------------------------------------------------------------------------------------------------------------------------------------------------------------------------------------------------------------------------------------------------------------------------------------------------------------------------------------------------------------------------------------------------------------------------------------------------------------------------------------------------------------------------------------------------------------------------------------------------------|----------------------|---------------|---------------|--------|----------------------------------------------------------------------------------------------------------------------------------------------------------------------------------------------------------------------------|-----|--------|-------------------------------------------------------------------------|----|---------|--------------------------|----|---------------|----------------|---------------|----------------|--------|----------|--------|-----|--------|----------|--------|-----|--------|------|--------|-----|--------|------|--------|-----|--------|------|--------|-----|--------|------|--------|-----|--------|------|--------|-----|--------|------|--------|-----|--------|------|--------|-----|--------|------|--------|-----|--------|-----|--------|-----|--------|-----|--------|-----|--------|-----|--------|-----|--------|-----|--------|-----|--------|-----|--------|-----|--------|-----|--------|-----|------------------------------------|--|------|
| PB17 | NHF | <p>Shaft resonance suppression filter Set a shaft resonance suppression filter. Use this to suppress a low-frequency machine vibration.</p> <p>When you select "Automatic setting (___ 0)" of "Shaft resonance suppression filter selection" in [Pr. PB23], the value will be calculated automatically from the servo motor you use and load to motor inertia ratio. It will not automatically calculated for the linear servo motor. When "Manual setting (___ 1)" is selected, the setting written to the parameter is used.</p> <p>When "Shaft resonance suppression filter selection" is "Disabled (___ 2)" in [Pr. PB23], the setting value of this parameter will be disabled.</p> <p>When you select "Enabled (___ 1)" of "Machine resonance suppression filter 4 selection" in [Pr. PB49], the shaft resonance suppression filter is not available.</p> <table border="1" data-bbox="344 678 1155 1097"> <thead> <tr> <th>Setting digit</th> <th>Explanation</th> <th>Initial value</th> </tr> </thead> <tbody> <tr> <td>__ x x</td> <td>Shaft resonance suppression filter setting frequency selection This is used for setting the shaft resonance suppression filter. Refer to table 5.4 for settings. Set the value closest to the frequency you need.</td> <td>00h</td> </tr> <tr> <td>_ x __</td> <td>Notch depth selection 0: -40 dB 1: -14 dB 2: -8 dB 3: -4 dB</td> <td>0h</td> </tr> <tr> <td>x __ __</td> <td>For manufacturer setting</td> <td>0h</td> </tr> </tbody> </table> <p style="text-align: center;">Table 5.4 Shaft resonance suppression filter setting frequency selection</p> <table border="1" data-bbox="344 1211 1078 1783"> <thead> <tr> <th>Setting value</th> <th>Frequency [Hz]</th> <th>Setting value</th> <th>Frequency [Hz]</th> </tr> </thead> <tbody> <tr><td>__ 0 0</td><td>Disabled</td><td>__ 1 0</td><td>562</td></tr> <tr><td>__ 0 1</td><td>Disabled</td><td>__ 1 1</td><td>529</td></tr> <tr><td>__ 0 2</td><td>4500</td><td>__ 1 2</td><td>500</td></tr> <tr><td>__ 0 3</td><td>3000</td><td>__ 1 3</td><td>473</td></tr> <tr><td>__ 0 4</td><td>2250</td><td>__ 1 4</td><td>450</td></tr> <tr><td>__ 0 5</td><td>1800</td><td>__ 1 5</td><td>428</td></tr> <tr><td>__ 0 6</td><td>1500</td><td>__ 1 6</td><td>409</td></tr> <tr><td>__ 0 7</td><td>1285</td><td>__ 1 7</td><td>391</td></tr> <tr><td>__ 0 8</td><td>1125</td><td>__ 1 8</td><td>375</td></tr> <tr><td>__ 0 9</td><td>1000</td><td>__ 1 9</td><td>360</td></tr> <tr><td>__ 0 A</td><td>900</td><td>__ 1 A</td><td>346</td></tr> <tr><td>__ 0 B</td><td>818</td><td>__ 1 B</td><td>333</td></tr> <tr><td>__ 0 C</td><td>750</td><td>__ 1 C</td><td>321</td></tr> <tr><td>__ 0 D</td><td>692</td><td>__ 1 D</td><td>310</td></tr> <tr><td>__ 0 E</td><td>642</td><td>__ 1 E</td><td>300</td></tr> <tr><td>__ 0 F</td><td>600</td><td>__ 1 F</td><td>290</td></tr> </tbody> </table> | Setting digit | Explanation | Initial value | __ x x | Shaft resonance suppression filter setting frequency selection This is used for setting the shaft resonance suppression filter. Refer to table 5.4 for settings. Set the value closest to the frequency you need. | 00h | _ x __ | Notch depth selection 0: -40 dB 1: -14 dB 2: -8 dB 3: -4 dB | 0h | x __ __ | For manufacturer setting | 0h | Setting value | Frequency [Hz] | Setting value | Frequency [Hz] | __ 0 0 | Disabled | __ 1 0 | 562 | __ 0 1 | Disabled | __ 1 1 | 529 | __ 0 2 | 4500 | __ 1 2 | 500 | __ 0 3 | 3000 | __ 1 3 | 473 | __ 0 4 | 2250 | __ 1 4 | 450 | __ 0 5 | 1800 | __ 1 5 | 428 | __ 0 6 | 1500 | __ 1 6 | 409 | __ 0 7 | 1285 | __ 1 7 | 391 | __ 0 8 | 1125 | __ 1 8 | 375 | __ 0 9 | 1000 | __ 1 9 | 360 | __ 0 A | 900 | __ 1 A | 346 | __ 0 B | 818 | __ 1 B | 333 | __ 0 C | 750 | __ 1 C | 321 | __ 0 D | 692 | __ 1 D | 310 | __ 0 E | 642 | __ 1 E | 300 | __ 0 F | 600 | __ 1 F | 290 | Refer to Name and function column. | | Each |
| Setting digit | Explanation | Initial value | | | | | | | | | | | | | | | | | | | | | | | | | | | | | | | | | | | | | | | | | | | | | | | | | | | | | | | | | | | | | | | | | | | | | | | | | | | | | | | | | | | |
| __ x x | Shaft resonance suppression filter setting frequency selection This is used for setting the shaft resonance suppression filter. Refer to table 5.4 for settings. Set the value closest to the frequency you need. | 00h | | | | | | | | | | | | | | | | | | | | | | | | | | | | | | | | | | | | | | | | | | | | | | | | | | | | | | | | | | | | | | | | | | | | | | | | | | | | | | | | | | | |
| _ x __ | Notch depth selection 0: -40 dB 1: -14 dB 2: -8 dB 3: -4 dB | 0h | | | | | | | | | | | | | | | | | | | | | | | | | | | | | | | | | | | | | | | | | | | | | | | | | | | | | | | | | | | | | | | | | | | | | | | | | | | | | | | | | | | |
| x __ __ | For manufacturer setting | 0h | | | | | | | | | | | | | | | | | | | | | | | | | | | | | | | | | | | | | | | | | | | | | | | | | | | | | | | | | | | | | | | | | | | | | | | | | | | | | | | | | | | |
| Setting value | Frequency [Hz] | Setting value | Frequency [Hz] | | | | | | | | | | | | | | | | | | | | | | | | | | | | | | | | | | | | | | | | | | | | | | | | | | | | | | | | | | | | | | | | | | | | | | | | | | | | | | | | | | |
| __ 0 0 | Disabled | __ 1 0 | 562 | | | | | | | | | | | | | | | | | | | | | | | | | | | | | | | | | | | | | | | | | | | | | | | | | | | | | | | | | | | | | | | | | | | | | | | | | | | | | | | | | | |
| __ 0 1 | Disabled | __ 1 1 | 529 | | | | | | | | | | | | | | | | | | | | | | | | | | | | | | | | | | | | | | | | | | | | | | | | | | | | | | | | | | | | | | | | | | | | | | | | | | | | | | | | | | |
| __ 0 2 | 4500 | __ 1 2 | 500 | | | | | | | | | | | | | | | | | | | | | | | | | | | | | | | | | | | | | | | | | | | | | | | | | | | | | | | | | | | | | | | | | | | | | | | | | | | | | | | | | | |
| __ 0 3 | 3000 | __ 1 3 | 473 | | | | | | | | | | | | | | | | | | | | | | | | | | | | | | | | | | | | | | | | | | | | | | | | | | | | | | | | | | | | | | | | | | | | | | | | | | | | | | | | | | |
| __ 0 4 | 2250 | __ 1 4 | 450 | | | | | | | | | | | | | | | | | | | | | | | | | | | | | | | | | | | | | | | | | | | | | | | | | | | | | | | | | | | | | | | | | | | | | | | | | | | | | | | | | | |
| __ 0 5 | 1800 | __ 1 5 | 428 | | | | | | | | | | | | | | | | | | | | | | | | | | | | | | | | | | | | | | | | | | | | | | | | | | | | | | | | | | | | | | | | | | | | | | | | | | | | | | | | | | |
| __ 0 6 | 1500 | __ 1 6 | 409 | | | | | | | | | | | | | | | | | | | | | | | | | | | | | | | | | | | | | | | | | | | | | | | | | | | | | | | | | | | | | | | | | | | | | | | | | | | | | | | | | | |
| __ 0 7 | 1285 | __ 1 7 | 391 | | | | | | | | | | | | | | | | | | | | | | | | | | | | | | | | | | | | | | | | | | | | | | | | | | | | | | | | | | | | | | | | | | | | | | | | | | | | | | | | | | |
| __ 0 8 | 1125 | __ 1 8 | 375 | | | | | | | | | | | | | | | | | | | | | | | | | | | | | | | | | | | | | | | | | | | | | | | | | | | | | | | | | | | | | | | | | | | | | | | | | | | | | | | | | | |
| __ 0 9 | 1000 | __ 1 9 | 360 | | | | | | | | | | | | | | | | | | | | | | | | | | | | | | | | | | | | | | | | | | | | | | | | | | | | | | | | | | | | | | | | | | | | | | | | | | | | | | | | | | |
| __ 0 A | 900 | __ 1 A | 346 | | | | | | | | | | | | | | | | | | | | | | | | | | | | | | | | | | | | | | | | | | | | | | | | | | | | | | | | | | | | | | | | | | | | | | | | | | | | | | | | | | |
| __ 0 B | 818 | __ 1 B | 333 | | | | | | | | | | | | | | | | | | | | | | | | | | | | | | | | | | | | | | | | | | | | | | | | | | | | | | | | | | | | | | | | | | | | | | | | | | | | | | | | | | |
| __ 0 C | 750 | __ 1 C | 321 | | | | | | | | | | | | | | | | | | | | | | | | | | | | | | | | | | | | | | | | | | | | | | | | | | | | | | | | | | | | | | | | | | | | | | | | | | | | | | | | | | |
| __ 0 D | 692 | __ 1 D | 310 | | | | | | | | | | | | | | | | | | | | | | | | | | | | | | | | | | | | | | | | | | | | | | | | | | | | | | | | | | | | | | | | | | | | | | | | | | | | | | | | | | |
| __ 0 E | 642 | __ 1 E | 300 | | | | | | | | | | | | | | | | | | | | | | | | | | | | | | | | | | | | | | | | | | | | | | | | | | | | | | | | | | | | | | | | | | | | | | | | | | | | | | | | | | |
| __ 0 F | 600 | __ 1 F | 290 | | | | | | | | | | | | | | | | | | | | | | | | | | | | | | | | | | | | | | | | | | | | | | | | | | | | | | | | | | | | | | | | | | | | | | | | | | | | | | | | | | |

5. PARAMETERS

| No. | Symbol | Name and function | Initial value [unit] | Setting range | Each/ Common | | | | | | | | | | | | | |
|-------------------------|------------------------------------------------------------------------------------------------------------------------------------------------------------------------------------------------------------------------------------------------------------------------------------------|-------------------------------------------------------------------------------------------------------------------------------------------------------------------------------------------------------------------------------------------------------------------------------------------------------------------------------------------------------------------------------------------------------------------------------------------------------------------------------------------------------------------------------------------------------------------------------------------------------------------------------------------------------------------------------------------------------------------------------------------------------------------------------------------------------------------------------------------------------------------------------|----------------------|---------------|-------------------------|-------------------|------------------------------------------------------------------------------------------------------------------------------------------------------------------------------------------------------------------------------------------------------------------------------------------|-----------------------|---------|-------------------------------------------------------------------------------------------------|--------------|--------------|--------------------------|----|---------|----|------------------------------------|------|
| PB18 | LPF | <p>Low-pass filter setting Set the low-pass filter. The following shows a relation of a required parameter to this parameter.</p> <table border="1"> <thead> <tr> <th>[Pr. PB23]</th> <th>[Pr. PB18]</th> </tr> </thead> <tbody> <tr> <td>__ 0 __ (Initial value)</td> <td>Automatic setting</td> </tr> <tr> <td>__ 1 __</td> <td>Setting value enabled</td> </tr> <tr> <td>__ 2 __</td> <td>Setting value disabled</td> </tr> </tbody> </table> | [Pr. PB23] | [Pr. PB18] | __ 0 __ (Initial value) | Automatic setting | __ 1 __ | Setting value enabled | __ 2 __ | Setting value disabled | 3141 [rad/s] | 100 to 18000 | Each | | | | | |
| [Pr. PB23] | [Pr. PB18] | | | | | | | | | | | | | | | | | |
| __ 0 __ (Initial value) | Automatic setting | | | | | | | | | | | | | | | | | |
| __ 1 __ | Setting value enabled | | | | | | | | | | | | | | | | | |
| __ 2 __ | Setting value disabled | | | | | | | | | | | | | | | | | |
| PB19 | VRF11 | <p>Vibration suppression control 1 - Vibration frequency Set the vibration frequency for vibration suppression control 1 to suppress low-frequency machine vibration. When "Vibration suppression control 1 tuning mode selection" is set to "Automatic setting (__ __ 1)" in [Pr. PB02], this parameter will be set automatically. When "Manual setting (__ __ 2)" is selected, the setting written to the parameter is used. The setting range of this parameter varies, depending on the value in [Pr. PB07]. If a value out of the range is set, the vibration suppression control will be disabled. Refer to section 7.1.5 for details.</p> | 100.0 [Hz] | 0.1 to 300.0 | Each | | | | | | | | | | | | | |
| PB20 | VRF12 | <p>Vibration suppression control 1 - Resonance frequency Set the resonance frequency for vibration suppression control 1 to suppress low-frequency machine vibration. When "Vibration suppression control 1 tuning mode selection" is set to "Automatic setting (__ __ 1)" in [Pr. PB02], this parameter will be set automatically. When "Manual setting (__ __ 2)" is selected, the setting written to the parameter is used. The setting range of this parameter varies, depending on the value in [Pr. PB07]. If a value out of the range is set, the vibration suppression control will be disabled. Refer to section 7.1.5 for details.</p> | 100.0 [Hz] | 0.1 to 300.0 | Each | | | | | | | | | | | | | |
| PB21 | VRF13 | <p>Vibration suppression control 1 - Vibration frequency damping Set a damping of the vibration frequency for vibration suppression control 1 to suppress low-frequency machine vibration. When "Vibration suppression control 1 tuning mode selection" is set to "Automatic setting (__ __ 1)" in [Pr. PB02], this parameter will be set automatically. When "Manual setting (__ __ 2)" is selected, the setting written to the parameter is used. Refer to section 7.1.5 for details.</p> | 0.00 | 0.00 to 0.30 | Each | | | | | | | | | | | | | |
| PB22 | VRF14 | <p>Vibration suppression control 1 - Resonance frequency damping Set a damping of the resonance frequency for vibration suppression control 1 to suppress low-frequency machine vibration. When "Vibration suppression control 1 tuning mode selection" is set to "Automatic setting (__ __ 1)" in [Pr. PB02], this parameter will be set automatically. When "Manual setting (__ __ 2)" is selected, the setting written to the parameter is used. Refer to section 7.1.5 for details.</p> | 0.00 | 0.00 to 0.30 | Each | | | | | | | | | | | | | |
| PB23 | VFBF | <p>Low-pass filter selection Select the shaft resonance suppression filter and low-pass filter.</p> <table border="1"> <thead> <tr> <th>Setting digit</th> <th>Explanation</th> <th>Initial value</th> </tr> </thead> <tbody> <tr> <td>___ x</td> <td> <p>Shaft resonance suppression filter selection 0: Automatic setting 1: Manual setting 2: Disabled When you select "Enabled (__ __ 1)" of "Machine resonance suppression filter 4 selection" in [Pr. PB49], the shaft resonance suppression filter is not available.</p> </td> <td>0h</td> </tr> <tr> <td>__ x _</td> <td> <p>Low-pass filter selection 0: Automatic setting 1: Manual setting 2: Disabled</p> </td> <td>0h</td> </tr> <tr> <td>_ x _ _</td> <td rowspan="2">For manufacturer setting</td> <td>0h</td> </tr> <tr> <td>x _ _ _</td> <td>0h</td> </tr> </tbody> </table> | Setting digit | Explanation | Initial value | ___ x | <p>Shaft resonance suppression filter selection 0: Automatic setting 1: Manual setting 2: Disabled When you select "Enabled (__ __ 1)" of "Machine resonance suppression filter 4 selection" in [Pr. PB49], the shaft resonance suppression filter is not available.</p> | 0h | __ x _ | <p>Low-pass filter selection 0: Automatic setting 1: Manual setting 2: Disabled</p> | 0h | _ x _ _ | For manufacturer setting | 0h | x _ _ _ | 0h | Refer to Name and function column. | Each |
| Setting digit | Explanation | Initial value | | | | | | | | | | | | | | | | |
| ___ x | <p>Shaft resonance suppression filter selection 0: Automatic setting 1: Manual setting 2: Disabled When you select "Enabled (__ __ 1)" of "Machine resonance suppression filter 4 selection" in [Pr. PB49], the shaft resonance suppression filter is not available.</p> | 0h | | | | | | | | | | | | | | | | |
| __ x _ | <p>Low-pass filter selection 0: Automatic setting 1: Manual setting 2: Disabled</p> | 0h | | | | | | | | | | | | | | | | |
| _ x _ _ | For manufacturer setting | 0h | | | | | | | | | | | | | | | | |
| x _ _ _ | | 0h | | | | | | | | | | | | | | | | |

5. PARAMETERS

| No. | Symbol | Name and function | Initial value [unit] | Setting range | Each/ Common | | | | | | | | | | | | | |
|---------------|---------------------------------------------------------------------------------------------------------------------------------------------------------------------------------------------------------------------------------------------------------------------------------------------------------------------------------------------------------------------------------------------------------------------------------------------------------------------------------------------------------------------------------------------------------------------------------------------------|-------------------------------------------------------------------------------------------------------------------------------------------------------------------------------------------------------------------------------------------------------------------------------------------------------------------------------------------------------------------------------------------------------------------------------------------------------------------------------------------------------------------------------------------------------------------------------------------------------------------------------------------------------------------------------------------------------------------------------------------------------------------------------------------------------------------------------------------------------------------------------------------------------------------------------------------------------------------------------------------------------------------------------------------------------------------------------------------------------------------------------------------------------------------------------------------------------------------------------------------------------------------------------------------------------------------------------------------------------------------------------------------------------------------|----------------------|---------------|---------------|------|---------------------------------------------------------------------------------------------------------------------------------------------------------------------------------------------------------------------------------------------------------------------------------------------------------------|----|------|---------------------------------------------------------------------------------------------------------------------------------------------------------------------------------------------------------------------------------------------------------------------------------------------------------------------------------------------------------------------------------------------------------------------------------------------------------------------------------------------------------------------------------------------------------------------------------------------------|----|------|--------------------------|------|------|------------------------------------|------------------------------------|------|
| PB24 | *MVS | <p>Slight vibration suppression control Select the slight vibration suppression control and PI-PID switching control.</p> <table border="1"> <thead> <tr> <th>Setting digit</th> <th>Explanation</th> <th>Initial value</th> </tr> </thead> <tbody> <tr> <td>___x</td> <td> <p>Slight vibration suppression control selection 0: Disabled 1: Enabled</p> <p>To enable the slight vibration suppression control, select "Manual mode (___3)" of "Gain adjustment mode selection" in [Pr. PA08]. Slight vibration suppression control cannot be used in the speed control mode.</p> </td> <td>0h</td> </tr> <tr> <td>__x_</td> <td> <p>PI-PID switching control selection 0: PI control enabled (Switching to PID control is possible with commands of servo system controller.) 3: Continuous PID control enabled</p> <p>If the servo motor at a stop is rotated even for a pulse due to any external factor, it generates torque to compensate for a position shift. When the servo motor shaft is to be locked mechanically after positioning completion (stop), enabling PID control and completing positioning simultaneously will suppress the unnecessary torque generated to compensate for a position shift.</p> </td> <td>0h</td> </tr> <tr> <td>_x__</td> <td rowspan="2">For manufacturer setting</td> <td>0h</td> </tr> <tr> <td>x___</td> <td>0h</td> </tr> </tbody> </table> | Setting digit | Explanation | Initial value | ___x | <p>Slight vibration suppression control selection 0: Disabled 1: Enabled</p> <p>To enable the slight vibration suppression control, select "Manual mode (___3)" of "Gain adjustment mode selection" in [Pr. PA08]. Slight vibration suppression control cannot be used in the speed control mode.</p> | 0h | __x_ | <p>PI-PID switching control selection 0: PI control enabled (Switching to PID control is possible with commands of servo system controller.) 3: Continuous PID control enabled</p> <p>If the servo motor at a stop is rotated even for a pulse due to any external factor, it generates torque to compensate for a position shift. When the servo motor shaft is to be locked mechanically after positioning completion (stop), enabling PID control and completing positioning simultaneously will suppress the unnecessary torque generated to compensate for a position shift.</p> | 0h | _x__ | For manufacturer setting | 0h | x___ | 0h | Refer to Name and function column. | Each |
| Setting digit | Explanation | Initial value | | | | | | | | | | | | | | | | |
| ___x | <p>Slight vibration suppression control selection 0: Disabled 1: Enabled</p> <p>To enable the slight vibration suppression control, select "Manual mode (___3)" of "Gain adjustment mode selection" in [Pr. PA08]. Slight vibration suppression control cannot be used in the speed control mode.</p> | 0h | | | | | | | | | | | | | | | | |
| __x_ | <p>PI-PID switching control selection 0: PI control enabled (Switching to PID control is possible with commands of servo system controller.) 3: Continuous PID control enabled</p> <p>If the servo motor at a stop is rotated even for a pulse due to any external factor, it generates torque to compensate for a position shift. When the servo motor shaft is to be locked mechanically after positioning completion (stop), enabling PID control and completing positioning simultaneously will suppress the unnecessary torque generated to compensate for a position shift.</p> | 0h | | | | | | | | | | | | | | | | |
| _x__ | For manufacturer setting | 0h | | | | | | | | | | | | | | | | |
| x___ | | 0h | | | | | | | | | | | | | | | | |
| PB25 | *BOP1 | <p>Function selection B-1 Select enabled/disabled of model adaptive control. This parameter is supported with software version B4 or later.</p> <table border="1"> <thead> <tr> <th>Setting digit</th> <th>Explanation</th> <th>Initial value</th> </tr> </thead> <tbody> <tr> <td>___x</td> <td> <p>Model adaptive control selection 0: Enabled (model adaptive control) 2: Disabled (PID control)</p> </td> <td>0h</td> </tr> <tr> <td>__x_</td> <td rowspan="3">For manufacturer setting</td> <td>0h</td> </tr> <tr> <td>_x__</td> <td>0h</td> </tr> <tr> <td>x___</td> <td>0h</td> </tr> </tbody> </table> | Setting digit | Explanation | Initial value | ___x | <p>Model adaptive control selection 0: Enabled (model adaptive control) 2: Disabled (PID control)</p> | 0h | __x_ | For manufacturer setting | 0h | _x__ | 0h | x___ | 0h | Refer to Name and function column. | Each | |
| Setting digit | Explanation | Initial value | | | | | | | | | | | | | | | | |
| ___x | <p>Model adaptive control selection 0: Enabled (model adaptive control) 2: Disabled (PID control)</p> | 0h | | | | | | | | | | | | | | | | |
| __x_ | For manufacturer setting | 0h | | | | | | | | | | | | | | | | |
| _x__ | | 0h | | | | | | | | | | | | | | | | |
| x___ | | 0h | | | | | | | | | | | | | | | | |

5. PARAMETERS

| No. | Symbol | Name and function | Initial value [unit] | Setting range | Each/ Common | | | | | | | | | | | | | | | |
|---------------|----------------------------------------------------------------------------------------------------------------------------------------------------------------------------------------------------------------------------------------------------------------------------------------------------|----------------------------------------------------------------------------------------------------------------------------------------------------------------------------------------------------------------------------------------------------------------------------------------------------------------------------------------------------------------------------------------------------------------------------------------------------------------------------------------------------------------------------------------------------------------------------------------------------------------------------------------------------------------------------------------------------------------------------------------------------------------------------------------------------------------------------------------------------------------------------------------------------------------------------------------------------------------------------------------------------------------------------------------------------------------------------------------------------------------------------------------------------------------------------------------------------------------------------------------------------------|------------------------------------------|----------------|---------------|------|--------------------------------------------------------------------------------------------------------------------------------------------------------------------------------------|----|------|--------------------------------------------------------------------------------------------------------------------------------------------------------------------------------------------|----|------|----------------------------------------------------------------------------------------------------------------------------------------------------------------------------------------------------------------------------------------------------------------------------------------------------|----|------|--------------------------|----|------------------------------------|--|------|
| PB26 | *CDP | <p>Gain switching function Select the gain switching condition. Set conditions to enable the gain switching values set in [Pr. PB29] to [Pr. PB36] and [Pr. PB56] to [Pr. PB60].</p> <table border="1"> <thead> <tr> <th>Setting digit</th> <th>Explanation</th> <th>Initial value</th> </tr> </thead> <tbody> <tr> <td>___x</td> <td>Gain switching selection 0: Disabled 1: Control command from controller is enabled 2: Command frequency 3: Droop pulses 4: Servo motor speed/linear servo motor speed</td> <td>0h</td> </tr> <tr> <td>__x_</td> <td>Gain switching condition selection 0: Gain after switching is enabled with gain switching condition or more 1: Gain after switching is enabled with gain switching condition or less</td> <td>0h</td> </tr> <tr> <td>_x__</td> <td>Gain switching time constant disabling condition selection 0: Switching time constant enabled 1: Switching time constant disabled 2: Return time constant disabled Refer to section 7.2.4 for details. This parameter is used by servo amplifier with software version B4 or later.</td> <td>0h</td> </tr> <tr> <td>x___</td> <td>For manufacturer setting</td> <td>0h</td> </tr> </tbody> </table> | Setting digit | Explanation | Initial value | ___x | Gain switching selection 0: Disabled 1: Control command from controller is enabled 2: Command frequency 3: Droop pulses 4: Servo motor speed/linear servo motor speed | 0h | __x_ | Gain switching condition selection 0: Gain after switching is enabled with gain switching condition or more 1: Gain after switching is enabled with gain switching condition or less | 0h | _x__ | Gain switching time constant disabling condition selection 0: Switching time constant enabled 1: Switching time constant disabled 2: Return time constant disabled Refer to section 7.2.4 for details. This parameter is used by servo amplifier with software version B4 or later. | 0h | x___ | For manufacturer setting | 0h | Refer to Name and function column. | | Each |
| Setting digit | Explanation | Initial value | | | | | | | | | | | | | | | | | | |
| ___x | Gain switching selection 0: Disabled 1: Control command from controller is enabled 2: Command frequency 3: Droop pulses 4: Servo motor speed/linear servo motor speed | 0h | | | | | | | | | | | | | | | | | | |
| __x_ | Gain switching condition selection 0: Gain after switching is enabled with gain switching condition or more 1: Gain after switching is enabled with gain switching condition or less | 0h | | | | | | | | | | | | | | | | | | |
| _x__ | Gain switching time constant disabling condition selection 0: Switching time constant enabled 1: Switching time constant disabled 2: Return time constant disabled Refer to section 7.2.4 for details. This parameter is used by servo amplifier with software version B4 or later. | 0h | | | | | | | | | | | | | | | | | | |
| x___ | For manufacturer setting | 0h | | | | | | | | | | | | | | | | | | |
| PB27 | CDL | <p>Gain switching condition Set a value of gain switching (command frequency, droop pulses, and servo motor speed/linear servo motor speed) selected in [Pr. PB26]. The set value unit differs depending on the switching condition item. (Refer to section 7.2.3) The unit "r/min" will be "mm/s" for linear servo motors.</p> | 10 [kpulse/s] /[pulse] /[r/min] | 0 to 65535 | Each | | | | | | | | | | | | | | | |
| PB28 | CDT | <p>Gain switching time constant Set the time constant until the gains switch in response to the conditions set in [Pr. PB26] and [Pr. PB27].</p> | 1 [ms] | 0 to 100 | Each | | | | | | | | | | | | | | | |
| PB29 | GD2B | <p>Load to motor inertia ratio/load to motor mass ratio after gain switching Set a load to motor inertia ratio/load to motor mass ratio for when gain switching is enabled. This parameter is enabled only when you select "Manual mode (___3)" of "Gain adjustment mode selection" in [Pr. PA08].</p> | 7.00 [Multiplier] | 0.00 to 300.00 | Each | | | | | | | | | | | | | | | |

5. PARAMETERS

| No. | Symbol | Name and function | Initial value [unit] | Setting range | Each/ Common |
|------|--------|-------------------------------------------------------------------------------------------------------------------------------------------------------------------------------------------------------------------------------------------------------------------------------------------------------------------------------------------------------------------------------------------------------------------------------------------------------------------------------------------------------------------------------------------------------------------------------------------------------------------------------------------------------------------------------------------------------------------------------------------------------------------------------------------------------------------------------------------------------|----------------------|------------------|--------------|
| PB30 | PG2B | Position loop gain after gain switching Set the position loop gain when the gain switching is enabled. When you set a value less than 1.0 rad/s, the value will be the same as [Pr. PB08]. This parameter is enabled only when you select "Manual mode (_ _ _ 3)" of "Gain adjustment mode selection" in [Pr. PA08]. | 0.0 [rad/s] | 0.0 to 2000.0 | Each |
| PB31 | VG2B | Speed loop gain after gain switching Set the speed loop gain when the gain switching is enabled. When you set a value less than 20 rad/s, the value will be the same as [Pr. PB09]. This parameter is enabled only when you select "Manual mode (_ _ _ 3)" of "Gain adjustment mode selection" in [Pr. PA08]. | 0 [rad/s] | 0 to 65535 | Each |
| PB32 | VICB | Speed integral compensation after gain switching Set the speed integral compensation when the gain changing is enabled. When you set a value less than 0.1 ms, the value will be the same as [Pr. PB10]. This parameter is enabled only when you select "Manual mode (_ _ _ 3)" of "Gain adjustment mode selection" in [Pr. PA08]. | 0.0 [ms] | 0.0 to 5000.0 | Each |
| PB33 | VRF11B | Vibration suppression control 1 - Vibration frequency after gain switching Set the vibration frequency of the vibration suppression control 1 for when the gain switching is enabled. When you set a value less than 0.1 Hz, the value will be the same as [Pr. PB19]. This parameter is enabled only when the following conditions are fulfilled. <ul style="list-style-type: none"> • "Gain adjustment mode selection" in [Pr. PA08] is "Manual mode (_ _ _ 3)". • "Vibration suppression control 1 tuning mode selection" in [Pr. PB02] is "Manual setting (_ _ _ 2)". • "Gain switching selection" in [Pr. PB26] is "Control command from controller is enabled (_ _ _ 1)". Switching during driving may cause a shock. Be sure to switch them after the servo motor or linear servo motor stops. | 0.0 [Hz] | 0.0 to 300.0 | Each |
| PB34 | VRF12B | Vibration suppression control 1 - Resonance frequency after gain switching Set the resonance frequency for vibration suppression control 1 when the gain switching is enabled. When you set a value less than 0.1 Hz, the value will be the same as [Pr. PB20]. This parameter will be enabled only when the following conditions are fulfilled. <ul style="list-style-type: none"> • "Gain adjustment mode selection" in [Pr. PA08] is "Manual mode (_ _ _ 3)". • "Vibration suppression control 1 tuning mode selection" in [Pr. PB02] is "Manual setting (_ _ _ 2)". • "Gain switching selection" in [Pr. PB26] is "Control command from controller is enabled (_ _ _ 1)". Switching during driving may cause a shock. Be sure to switch them after the servo motor or linear servo motor stops. | 0.0 [Hz] | 0.0 to 300.0 | Each |
| PB35 | VRF13B | Vibration suppression control 1 - Vibration frequency damping after gain switching Set a damping of the vibration frequency for vibration suppression control 1 when the gain switching is enabled. This parameter will be enabled only when the following conditions are fulfilled. <ul style="list-style-type: none"> • "Gain adjustment mode selection" in [Pr. PA08] is "Manual mode (_ _ _ 3)". • "Vibration suppression control 1 tuning mode selection" in [Pr. PB02] is "Manual setting (_ _ _ 2)". • "Gain switching selection" in [Pr. PB26] is "Control command from controller is enabled (_ _ _ 1)". Switching during driving may cause a shock. Be sure to switch them after the servo motor or linear servo motor stops. | 0.00 | 0.00 to 0.30 | Each |
| PB36 | VRF14B | Vibration suppression control 1 - Resonance frequency damping after gain switching Set a damping of the resonance frequency for vibration suppression control 1 when the gain switching is enabled. This parameter will be enabled only when the following conditions are fulfilled. <ul style="list-style-type: none"> • "Gain adjustment mode selection" in [Pr. PA08] is "Manual mode (_ _ _ 3)". • "Vibration suppression control 1 tuning mode selection" in [Pr. PB02] is "Manual setting (_ _ _ 2)". • "Gain switching selection" in [Pr. PB26] is "Control command from controller is enabled (_ _ _ 1)". Switching during driving may cause a shock. Be sure to switch them after the servo motor or linear servo motor stops. | 0.00 | 0.00 to 0.30 | Each |

5. PARAMETERS

| No. | Symbol | Name and function | Initial value [unit] | Setting range | Each/ Common | | | | | | | | | | | | | | | | | | | | | | | | | | | | | | | | | | | | | | | | | | | | | | | | | | | | | | | | | | | | | | | | | | | | | | | | | | | | | | | | | | | | | | | | | | | | | | | | | | | | | | | | | | | | | | | | | | | | | | | | | | | | | | | | | | | | | | | | | | | | | | | | | | | | | | | | | | | | | | | | | | | | | | | | | | | | | | | | | | | | | | | | | | | | | | | | | | | |
|---------------|-------------------------------------------------------------------------------------------------------------------------|----------------------------------------------------------------------------------------------------------------------------------------------------------------------------------------------------------------------------------------------------------------------------------------------------------------------------------------------------------------------------------------------------------------------------------------------------------------------------------------------------------------------------------------------------------------------------------------------------------------------------------------------------------------------------------------------------------------------------------------------------------------------------------------------------------------------------------------------------------------------------------------------------------------------------------------------------------------------------------------------------------------------------------------------------------------------------------------------------------------------------------------------------------------------------------------------------------------------------------------------------------------------------------------------------------------------------------------------------------------------------------------------------------------------------------------------------------------------------------------------------------------------------------------------------------------------------------------------------------------------------------------------------------------------------------------------------------------------------------------------------------------------------------------------------------------------------------------------------------------------------------------------------------------------------------------------------------------------------------------------------------------------------------------------------------------------------------------------------------------------------------------------------------------------------------------------------------------------------------------------------------------------------------------------------------------------------------------------------------------------------------------------------------------------------------------------------------------------------------------------------------------------------------------------------------------------------------------------------------------------------------------------------------------------------------------------------------------------------------------------------------------------------------------------------------------------------------------------------------------------------------------------------------------------------------------------------------------------------------------------------------------------------------------------------------------------------------------------------------------------------------------------------------------------------------------------------------------------------------------------------------------------------------------------------------------------------------|------------------------------------|----------------|----------------|----------------|---------------|----------------|--------|-------------------------------------------------------------------------------------------------------------------------|--------|---------|----------------------------------------------------------|------|---------|--------------------------|--------|----|--------|------|--------|------|--------|----|--------|------|--------|-----|--------|----|--------|------|--------|-----|--------|----|--------|------|--------|-----|--------|----|--------|------|--------|-----|--------|----|--------|------|--------|-----|--------|----|--------|------|--------|-----|--------|----|--------|------|--------|-----|--------|----|--------|------|--------|-----|--------|----|--------|------|--------|-----|--------|----|--------|------|--------|-----|--------|----|--------|----|--------|-----|--------|----|--------|-----|--------|-----|--------|----|--------|-----|--------|-----|--------|----|--------|-----|--------|-----|--------|------|--------|-----|--------|-----|--------|------|--------|-----|--------|-----|--------|------|--------|-----|--------|-----|--------|------|--------|-----|--------|-----|--------|------|--------|-----|--------|-----|--------|------|--------|-----|--------|-----|--------|------|--------|-----|--------|----|--------|------|--------|-----|--------|----|--------|------|--------|-----|--------|----|--------|------|--------|-----|--------|----|--------|------|--------|-----|--------|----|--------|------|--------|-----|--------|----|--------|------|--------|-----|--------|----|--------|------|--------|-----|--------|----|--------|------|--------|-----|--------|----|--------|------|--------|-----|
| PB45 | CNHF | Command notch filter Set the command notch filter. | Refer to Name and function column. | | Each | | | | | | | | | | | | | | | | | | | | | | | | | | | | | | | | | | | | | | | | | | | | | | | | | | | | | | | | | | | | | | | | | | | | | | | | | | | | | | | | | | | | | | | | | | | | | | | | | | | | | | | | | | | | | | | | | | | | | | | | | | | | | | | | | | | | | | | | | | | | | | | | | | | | | | | | | | | | | | | | | | | | | | | | | | | | | | | | | | | | | | | | | | | | | | | | | | | |
| | | <table border="1"> <thead> <tr> <th>Setting digit</th> <th>Explanation</th> <th>Initial value</th> </tr> </thead> <tbody> <tr> <td>__ x x</td> <td>Command notch filter setting frequency selection Refer to table 5.5 for the relation of setting values to frequency.</td> <td>00h</td> </tr> <tr> <td>_ x _ _</td> <td>Notch depth selection Refer to table 5.6 for details.</td> <td>0h</td> </tr> <tr> <td>x _ _ _</td> <td>For manufacturer setting</td> <td>0h</td> </tr> </tbody> </table> | | | | Setting digit | Explanation | Initial value | __ x x | Command notch filter setting frequency selection Refer to table 5.5 for the relation of setting values to frequency. | 00h | _ x _ _ | Notch depth selection Refer to table 5.6 for details. | 0h | x _ _ _ | For manufacturer setting | 0h | | | | | | | | | | | | | | | | | | | | | | | | | | | | | | | | | | | | | | | | | | | | | | | | | | | | | | | | | | | | | | | | | | | | | | | | | | | | | | | | | | | | | | | | | | | | | | | | | | | | | | | | | | | | | | | | | | | | | | | | | | | | | | | | | | | | | | | | | | | | | | | | | | | | | | | | | | | | | | | | | | | | | | | | | | | | | | | | | | | | | | | |
| Setting digit | Explanation | Initial value | | | | | | | | | | | | | | | | | | | | | | | | | | | | | | | | | | | | | | | | | | | | | | | | | | | | | | | | | | | | | | | | | | | | | | | | | | | | | | | | | | | | | | | | | | | | | | | | | | | | | | | | | | | | | | | | | | | | | | | | | | | | | | | | | | | | | | | | | | | | | | | | | | | | | | | | | | | | | | | | | | | | | | | | | | | | | | | | | | | | | | | | | | | | | | | | | | | | | | |
| __ x x | Command notch filter setting frequency selection Refer to table 5.5 for the relation of setting values to frequency. | 00h | | | | | | | | | | | | | | | | | | | | | | | | | | | | | | | | | | | | | | | | | | | | | | | | | | | | | | | | | | | | | | | | | | | | | | | | | | | | | | | | | | | | | | | | | | | | | | | | | | | | | | | | | | | | | | | | | | | | | | | | | | | | | | | | | | | | | | | | | | | | | | | | | | | | | | | | | | | | | | | | | | | | | | | | | | | | | | | | | | | | | | | | | | | | | | | | | | | | | | |
| _ x _ _ | Notch depth selection Refer to table 5.6 for details. | 0h | | | | | | | | | | | | | | | | | | | | | | | | | | | | | | | | | | | | | | | | | | | | | | | | | | | | | | | | | | | | | | | | | | | | | | | | | | | | | | | | | | | | | | | | | | | | | | | | | | | | | | | | | | | | | | | | | | | | | | | | | | | | | | | | | | | | | | | | | | | | | | | | | | | | | | | | | | | | | | | | | | | | | | | | | | | | | | | | | | | | | | | | | | | | | | | | | | | | | | |
| x _ _ _ | For manufacturer setting | 0h | | | | | | | | | | | | | | | | | | | | | | | | | | | | | | | | | | | | | | | | | | | | | | | | | | | | | | | | | | | | | | | | | | | | | | | | | | | | | | | | | | | | | | | | | | | | | | | | | | | | | | | | | | | | | | | | | | | | | | | | | | | | | | | | | | | | | | | | | | | | | | | | | | | | | | | | | | | | | | | | | | | | | | | | | | | | | | | | | | | | | | | | | | | | | | | | | | | | | | |
| | | <p>Table 5.5 Command notch filter setting frequency selection</p> <table border="1"> <thead> <tr> <th>Setting value</th> <th>Frequency [Hz]</th> <th>Setting value</th> <th>Frequency [Hz]</th> <th>Setting value</th> <th>Frequency [Hz]</th> </tr> </thead> <tbody> <tr><td>__ 0 0</td><td>Disabled</td><td>__ 2 0</td><td>70</td><td>__ 4 0</td><td>17.6</td></tr> <tr><td>__ 0 1</td><td>2250</td><td>__ 2 1</td><td>66</td><td>__ 4 1</td><td>16.5</td></tr> <tr><td>__ 0 2</td><td>1125</td><td>__ 2 2</td><td>62</td><td>__ 4 2</td><td>15.6</td></tr> <tr><td>__ 0 3</td><td>750</td><td>__ 2 3</td><td>59</td><td>__ 4 3</td><td>14.8</td></tr> <tr><td>__ 0 4</td><td>562</td><td>__ 2 4</td><td>56</td><td>__ 4 4</td><td>14.1</td></tr> <tr><td>__ 0 5</td><td>450</td><td>__ 2 5</td><td>53</td><td>__ 4 5</td><td>13.4</td></tr> <tr><td>__ 0 6</td><td>375</td><td>__ 2 6</td><td>51</td><td>__ 4 6</td><td>12.8</td></tr> <tr><td>__ 0 7</td><td>321</td><td>__ 2 7</td><td>48</td><td>__ 4 7</td><td>12.2</td></tr> <tr><td>__ 0 8</td><td>281</td><td>__ 2 8</td><td>46</td><td>__ 4 8</td><td>11.7</td></tr> <tr><td>__ 0 9</td><td>250</td><td>__ 2 9</td><td>45</td><td>__ 4 9</td><td>11.3</td></tr> <tr><td>__ 0 A</td><td>225</td><td>__ 2 A</td><td>43</td><td>__ 4 A</td><td>10.8</td></tr> <tr><td>__ 0 B</td><td>204</td><td>__ 2 B</td><td>41</td><td>__ 4 B</td><td>10.4</td></tr> <tr><td>__ 0 C</td><td>187</td><td>__ 2 C</td><td>40</td><td>__ 4 C</td><td>10</td></tr> <tr><td>__ 0 D</td><td>173</td><td>__ 2 D</td><td>38</td><td>__ 4 D</td><td>9.7</td></tr> <tr><td>__ 0 E</td><td>160</td><td>__ 2 E</td><td>37</td><td>__ 4 E</td><td>9.4</td></tr> <tr><td>__ 0 F</td><td>150</td><td>__ 2 F</td><td>36</td><td>__ 4 F</td><td>9.1</td></tr> <tr><td>__ 1 0</td><td>140</td><td>__ 3 0</td><td>35.2</td><td>__ 5 0</td><td>8.8</td></tr> <tr><td>__ 1 1</td><td>132</td><td>__ 3 1</td><td>33.1</td><td>__ 5 1</td><td>8.3</td></tr> <tr><td>__ 1 2</td><td>125</td><td>__ 3 2</td><td>31.3</td><td>__ 5 2</td><td>7.8</td></tr> <tr><td>__ 1 3</td><td>118</td><td>__ 3 3</td><td>29.6</td><td>__ 5 3</td><td>7.4</td></tr> <tr><td>__ 1 4</td><td>112</td><td>__ 3 4</td><td>28.1</td><td>__ 5 4</td><td>7.0</td></tr> <tr><td>__ 1 5</td><td>107</td><td>__ 3 5</td><td>26.8</td><td>__ 5 5</td><td>6.7</td></tr> <tr><td>__ 1 6</td><td>102</td><td>__ 3 6</td><td>25.6</td><td>__ 5 6</td><td>6.4</td></tr> <tr><td>__ 1 7</td><td>97</td><td>__ 3 7</td><td>24.5</td><td>__ 5 7</td><td>6.1</td></tr> <tr><td>__ 1 8</td><td>93</td><td>__ 3 8</td><td>23.4</td><td>__ 5 8</td><td>5.9</td></tr> <tr><td>__ 1 9</td><td>90</td><td>__ 3 9</td><td>22.5</td><td>__ 5 9</td><td>5.6</td></tr> <tr><td>__ 1 A</td><td>86</td><td>__ 3 A</td><td>21.6</td><td>__ 5 A</td><td>5.4</td></tr> <tr><td>__ 1 B</td><td>83</td><td>__ 3 B</td><td>20.8</td><td>__ 5 B</td><td>5.2</td></tr> <tr><td>__ 1 C</td><td>80</td><td>__ 3 C</td><td>20.1</td><td>__ 5 C</td><td>5.0</td></tr> <tr><td>__ 1 D</td><td>77</td><td>__ 3 D</td><td>19.4</td><td>__ 5 D</td><td>4.9</td></tr> <tr><td>__ 1 E</td><td>75</td><td>__ 3 E</td><td>18.8</td><td>__ 5 E</td><td>4.7</td></tr> <tr><td>__ 1 F</td><td>72</td><td>__ 3 F</td><td>18.2</td><td>__ 5 F</td><td>4.5</td></tr> </tbody> </table> | Setting value | Frequency [Hz] | Setting value | Frequency [Hz] | Setting value | Frequency [Hz] | __ 0 0 | Disabled | __ 2 0 | 70 | __ 4 0 | 17.6 | __ 0 1 | 2250 | __ 2 1 | 66 | __ 4 1 | 16.5 | __ 0 2 | 1125 | __ 2 2 | 62 | __ 4 2 | 15.6 | __ 0 3 | 750 | __ 2 3 | 59 | __ 4 3 | 14.8 | __ 0 4 | 562 | __ 2 4 | 56 | __ 4 4 | 14.1 | __ 0 5 | 450 | __ 2 5 | 53 | __ 4 5 | 13.4 | __ 0 6 | 375 | __ 2 6 | 51 | __ 4 6 | 12.8 | __ 0 7 | 321 | __ 2 7 | 48 | __ 4 7 | 12.2 | __ 0 8 | 281 | __ 2 8 | 46 | __ 4 8 | 11.7 | __ 0 9 | 250 | __ 2 9 | 45 | __ 4 9 | 11.3 | __ 0 A | 225 | __ 2 A | 43 | __ 4 A | 10.8 | __ 0 B | 204 | __ 2 B | 41 | __ 4 B | 10.4 | __ 0 C | 187 | __ 2 C | 40 | __ 4 C | 10 | __ 0 D | 173 | __ 2 D | 38 | __ 4 D | 9.7 | __ 0 E | 160 | __ 2 E | 37 | __ 4 E | 9.4 | __ 0 F | 150 | __ 2 F | 36 | __ 4 F | 9.1 | __ 1 0 | 140 | __ 3 0 | 35.2 | __ 5 0 | 8.8 | __ 1 1 | 132 | __ 3 1 | 33.1 | __ 5 1 | 8.3 | __ 1 2 | 125 | __ 3 2 | 31.3 | __ 5 2 | 7.8 | __ 1 3 | 118 | __ 3 3 | 29.6 | __ 5 3 | 7.4 | __ 1 4 | 112 | __ 3 4 | 28.1 | __ 5 4 | 7.0 | __ 1 5 | 107 | __ 3 5 | 26.8 | __ 5 5 | 6.7 | __ 1 6 | 102 | __ 3 6 | 25.6 | __ 5 6 | 6.4 | __ 1 7 | 97 | __ 3 7 | 24.5 | __ 5 7 | 6.1 | __ 1 8 | 93 | __ 3 8 | 23.4 | __ 5 8 | 5.9 | __ 1 9 | 90 | __ 3 9 | 22.5 | __ 5 9 | 5.6 | __ 1 A | 86 | __ 3 A | 21.6 | __ 5 A | 5.4 | __ 1 B | 83 | __ 3 B | 20.8 | __ 5 B | 5.2 | __ 1 C | 80 | __ 3 C | 20.1 | __ 5 C | 5.0 | __ 1 D | 77 | __ 3 D | 19.4 | __ 5 D | 4.9 | __ 1 E | 75 | __ 3 E | 18.8 | __ 5 E | 4.7 | __ 1 F | 72 | __ 3 F | 18.2 | __ 5 F | 4.5 |
| Setting value | Frequency [Hz] | Setting value | Frequency [Hz] | Setting value | Frequency [Hz] | | | | | | | | | | | | | | | | | | | | | | | | | | | | | | | | | | | | | | | | | | | | | | | | | | | | | | | | | | | | | | | | | | | | | | | | | | | | | | | | | | | | | | | | | | | | | | | | | | | | | | | | | | | | | | | | | | | | | | | | | | | | | | | | | | | | | | | | | | | | | | | | | | | | | | | | | | | | | | | | | | | | | | | | | | | | | | | | | | | | | | | | | | | | | | | | | | | |
| __ 0 0 | Disabled | __ 2 0 | 70 | __ 4 0 | 17.6 | | | | | | | | | | | | | | | | | | | | | | | | | | | | | | | | | | | | | | | | | | | | | | | | | | | | | | | | | | | | | | | | | | | | | | | | | | | | | | | | | | | | | | | | | | | | | | | | | | | | | | | | | | | | | | | | | | | | | | | | | | | | | | | | | | | | | | | | | | | | | | | | | | | | | | | | | | | | | | | | | | | | | | | | | | | | | | | | | | | | | | | | | | | | | | | | | | | |
| __ 0 1 | 2250 | __ 2 1 | 66 | __ 4 1 | 16.5 | | | | | | | | | | | | | | | | | | | | | | | | | | | | | | | | | | | | | | | | | | | | | | | | | | | | | | | | | | | | | | | | | | | | | | | | | | | | | | | | | | | | | | | | | | | | | | | | | | | | | | | | | | | | | | | | | | | | | | | | | | | | | | | | | | | | | | | | | | | | | | | | | | | | | | | | | | | | | | | | | | | | | | | | | | | | | | | | | | | | | | | | | | | | | | | | | | | |
| __ 0 2 | 1125 | __ 2 2 | 62 | __ 4 2 | 15.6 | | | | | | | | | | | | | | | | | | | | | | | | | | | | | | | | | | | | | | | | | | | | | | | | | | | | | | | | | | | | | | | | | | | | | | | | | | | | | | | | | | | | | | | | | | | | | | | | | | | | | | | | | | | | | | | | | | | | | | | | | | | | | | | | | | | | | | | | | | | | | | | | | | | | | | | | | | | | | | | | | | | | | | | | | | | | | | | | | | | | | | | | | | | | | | | | | | | |
| __ 0 3 | 750 | __ 2 3 | 59 | __ 4 3 | 14.8 | | | | | | | | | | | | | | | | | | | | | | | | | | | | | | | | | | | | | | | | | | | | | | | | | | | | | | | | | | | | | | | | | | | | | | | | | | | | | | | | | | | | | | | | | | | | | | | | | | | | | | | | | | | | | | | | | | | | | | | | | | | | | | | | | | | | | | | | | | | | | | | | | | | | | | | | | | | | | | | | | | | | | | | | | | | | | | | | | | | | | | | | | | | | | | | | | | | |
| __ 0 4 | 562 | __ 2 4 | 56 | __ 4 4 | 14.1 | | | | | | | | | | | | | | | | | | | | | | | | | | | | | | | | | | | | | | | | | | | | | | | | | | | | | | | | | | | | | | | | | | | | | | | | | | | | | | | | | | | | | | | | | | | | | | | | | | | | | | | | | | | | | | | | | | | | | | | | | | | | | | | | | | | | | | | | | | | | | | | | | | | | | | | | | | | | | | | | | | | | | | | | | | | | | | | | | | | | | | | | | | | | | | | | | | | |
| __ 0 5 | 450 | __ 2 5 | 53 | __ 4 5 | 13.4 | | | | | | | | | | | | | | | | | | | | | | | | | | | | | | | | | | | | | | | | | | | | | | | | | | | | | | | | | | | | | | | | | | | | | | | | | | | | | | | | | | | | | | | | | | | | | | | | | | | | | | | | | | | | | | | | | | | | | | | | | | | | | | | | | | | | | | | | | | | | | | | | | | | | | | | | | | | | | | | | | | | | | | | | | | | | | | | | | | | | | | | | | | | | | | | | | | | |
| __ 0 6 | 375 | __ 2 6 | 51 | __ 4 6 | 12.8 | | | | | | | | | | | | | | | | | | | | | | | | | | | | | | | | | | | | | | | | | | | | | | | | | | | | | | | | | | | | | | | | | | | | | | | | | | | | | | | | | | | | | | | | | | | | | | | | | | | | | | | | | | | | | | | | | | | | | | | | | | | | | | | | | | | | | | | | | | | | | | | | | | | | | | | | | | | | | | | | | | | | | | | | | | | | | | | | | | | | | | | | | | | | | | | | | | | |
| __ 0 7 | 321 | __ 2 7 | 48 | __ 4 7 | 12.2 | | | | | | | | | | | | | | | | | | | | | | | | | | | | | | | | | | | | | | | | | | | | | | | | | | | | | | | | | | | | | | | | | | | | | | | | | | | | | | | | | | | | | | | | | | | | | | | | | | | | | | | | | | | | | | | | | | | | | | | | | | | | | | | | | | | | | | | | | | | | | | | | | | | | | | | | | | | | | | | | | | | | | | | | | | | | | | | | | | | | | | | | | | | | | | | | | | | |
| __ 0 8 | 281 | __ 2 8 | 46 | __ 4 8 | 11.7 | | | | | | | | | | | | | | | | | | | | | | | | | | | | | | | | | | | | | | | | | | | | | | | | | | | | | | | | | | | | | | | | | | | | | | | | | | | | | | | | | | | | | | | | | | | | | | | | | | | | | | | | | | | | | | | | | | | | | | | | | | | | | | | | | | | | | | | | | | | | | | | | | | | | | | | | | | | | | | | | | | | | | | | | | | | | | | | | | | | | | | | | | | | | | | | | | | | |
| __ 0 9 | 250 | __ 2 9 | 45 | __ 4 9 | 11.3 | | | | | | | | | | | | | | | | | | | | | | | | | | | | | | | | | | | | | | | | | | | | | | | | | | | | | | | | | | | | | | | | | | | | | | | | | | | | | | | | | | | | | | | | | | | | | | | | | | | | | | | | | | | | | | | | | | | | | | | | | | | | | | | | | | | | | | | | | | | | | | | | | | | | | | | | | | | | | | | | | | | | | | | | | | | | | | | | | | | | | | | | | | | | | | | | | | | |
| __ 0 A | 225 | __ 2 A | 43 | __ 4 A | 10.8 | | | | | | | | | | | | | | | | | | | | | | | | | | | | | | | | | | | | | | | | | | | | | | | | | | | | | | | | | | | | | | | | | | | | | | | | | | | | | | | | | | | | | | | | | | | | | | | | | | | | | | | | | | | | | | | | | | | | | | | | | | | | | | | | | | | | | | | | | | | | | | | | | | | | | | | | | | | | | | | | | | | | | | | | | | | | | | | | | | | | | | | | | | | | | | | | | | | |
| __ 0 B | 204 | __ 2 B | 41 | __ 4 B | 10.4 | | | | | | | | | | | | | | | | | | | | | | | | | | | | | | | | | | | | | | | | | | | | | | | | | | | | | | | | | | | | | | | | | | | | | | | | | | | | | | | | | | | | | | | | | | | | | | | | | | | | | | | | | | | | | | | | | | | | | | | | | | | | | | | | | | | | | | | | | | | | | | | | | | | | | | | | | | | | | | | | | | | | | | | | | | | | | | | | | | | | | | | | | | | | | | | | | | | |
| __ 0 C | 187 | __ 2 C | 40 | __ 4 C | 10 | | | | | | | | | | | | | | | | | | | | | | | | | | | | | | | | | | | | | | | | | | | | | | | | | | | | | | | | | | | | | | | | | | | | | | | | | | | | | | | | | | | | | | | | | | | | | | | | | | | | | | | | | | | | | | | | | | | | | | | | | | | | | | | | | | | | | | | | | | | | | | | | | | | | | | | | | | | | | | | | | | | | | | | | | | | | | | | | | | | | | | | | | | | | | | | | | | | |
| __ 0 D | 173 | __ 2 D | 38 | __ 4 D | 9.7 | | | | | | | | | | | | | | | | | | | | | | | | | | | | | | | | | | | | | | | | | | | | | | | | | | | | | | | | | | | | | | | | | | | | | | | | | | | | | | | | | | | | | | | | | | | | | | | | | | | | | | | | | | | | | | | | | | | | | | | | | | | | | | | | | | | | | | | | | | | | | | | | | | | | | | | | | | | | | | | | | | | | | | | | | | | | | | | | | | | | | | | | | | | | | | | | | | | |
| __ 0 E | 160 | __ 2 E | 37 | __ 4 E | 9.4 | | | | | | | | | | | | | | | | | | | | | | | | | | | | | | | | | | | | | | | | | | | | | | | | | | | | | | | | | | | | | | | | | | | | | | | | | | | | | | | | | | | | | | | | | | | | | | | | | | | | | | | | | | | | | | | | | | | | | | | | | | | | | | | | | | | | | | | | | | | | | | | | | | | | | | | | | | | | | | | | | | | | | | | | | | | | | | | | | | | | | | | | | | | | | | | | | | | |
| __ 0 F | 150 | __ 2 F | 36 | __ 4 F | 9.1 | | | | | | | | | | | | | | | | | | | | | | | | | | | | | | | | | | | | | | | | | | | | | | | | | | | | | | | | | | | | | | | | | | | | | | | | | | | | | | | | | | | | | | | | | | | | | | | | | | | | | | | | | | | | | | | | | | | | | | | | | | | | | | | | | | | | | | | | | | | | | | | | | | | | | | | | | | | | | | | | | | | | | | | | | | | | | | | | | | | | | | | | | | | | | | | | | | | |
| __ 1 0 | 140 | __ 3 0 | 35.2 | __ 5 0 | 8.8 | | | | | | | | | | | | | | | | | | | | | | | | | | | | | | | | | | | | | | | | | | | | | | | | | | | | | | | | | | | | | | | | | | | | | | | | | | | | | | | | | | | | | | | | | | | | | | | | | | | | | | | | | | | | | | | | | | | | | | | | | | | | | | | | | | | | | | | | | | | | | | | | | | | | | | | | | | | | | | | | | | | | | | | | | | | | | | | | | | | | | | | | | | | | | | | | | | | |
| __ 1 1 | 132 | __ 3 1 | 33.1 | __ 5 1 | 8.3 | | | | | | | | | | | | | | | | | | | | | | | | | | | | | | | | | | | | | | | | | | | | | | | | | | | | | | | | | | | | | | | | | | | | | | | | | | | | | | | | | | | | | | | | | | | | | | | | | | | | | | | | | | | | | | | | | | | | | | | | | | | | | | | | | | | | | | | | | | | | | | | | | | | | | | | | | | | | | | | | | | | | | | | | | | | | | | | | | | | | | | | | | | | | | | | | | | | |
| __ 1 2 | 125 | __ 3 2 | 31.3 | __ 5 2 | 7.8 | | | | | | | | | | | | | | | | | | | | | | | | | | | | | | | | | | | | | | | | | | | | | | | | | | | | | | | | | | | | | | | | | | | | | | | | | | | | | | | | | | | | | | | | | | | | | | | | | | | | | | | | | | | | | | | | | | | | | | | | | | | | | | | | | | | | | | | | | | | | | | | | | | | | | | | | | | | | | | | | | | | | | | | | | | | | | | | | | | | | | | | | | | | | | | | | | | | |
| __ 1 3 | 118 | __ 3 3 | 29.6 | __ 5 3 | 7.4 | | | | | | | | | | | | | | | | | | | | | | | | | | | | | | | | | | | | | | | | | | | | | | | | | | | | | | | | | | | | | | | | | | | | | | | | | | | | | | | | | | | | | | | | | | | | | | | | | | | | | | | | | | | | | | | | | | | | | | | | | | | | | | | | | | | | | | | | | | | | | | | | | | | | | | | | | | | | | | | | | | | | | | | | | | | | | | | | | | | | | | | | | | | | | | | | | | | |
| __ 1 4 | 112 | __ 3 4 | 28.1 | __ 5 4 | 7.0 | | | | | | | | | | | | | | | | | | | | | | | | | | | | | | | | | | | | | | | | | | | | | | | | | | | | | | | | | | | | | | | | | | | | | | | | | | | | | | | | | | | | | | | | | | | | | | | | | | | | | | | | | | | | | | | | | | | | | | | | | | | | | | | | | | | | | | | | | | | | | | | | | | | | | | | | | | | | | | | | | | | | | | | | | | | | | | | | | | | | | | | | | | | | | | | | | | | |
| __ 1 5 | 107 | __ 3 5 | 26.8 | __ 5 5 | 6.7 | | | | | | | | | | | | | | | | | | | | | | | | | | | | | | | | | | | | | | | | | | | | | | | | | | | | | | | | | | | | | | | | | | | | | | | | | | | | | | | | | | | | | | | | | | | | | | | | | | | | | | | | | | | | | | | | | | | | | | | | | | | | | | | | | | | | | | | | | | | | | | | | | | | | | | | | | | | | | | | | | | | | | | | | | | | | | | | | | | | | | | | | | | | | | | | | | | | |
| __ 1 6 | 102 | __ 3 6 | 25.6 | __ 5 6 | 6.4 | | | | | | | | | | | | | | | | | | | | | | | | | | | | | | | | | | | | | | | | | | | | | | | | | | | | | | | | | | | | | | | | | | | | | | | | | | | | | | | | | | | | | | | | | | | | | | | | | | | | | | | | | | | | | | | | | | | | | | | | | | | | | | | | | | | | | | | | | | | | | | | | | | | | | | | | | | | | | | | | | | | | | | | | | | | | | | | | | | | | | | | | | | | | | | | | | | | |
| __ 1 7 | 97 | __ 3 7 | 24.5 | __ 5 7 | 6.1 | | | | | | | | | | | | | | | | | | | | | | | | | | | | | | | | | | | | | | | | | | | | | | | | | | | | | | | | | | | | | | | | | | | | | | | | | | | | | | | | | | | | | | | | | | | | | | | | | | | | | | | | | | | | | | | | | | | | | | | | | | | | | | | | | | | | | | | | | | | | | | | | | | | | | | | | | | | | | | | | | | | | | | | | | | | | | | | | | | | | | | | | | | | | | | | | | | | |
| __ 1 8 | 93 | __ 3 8 | 23.4 | __ 5 8 | 5.9 | | | | | | | | | | | | | | | | | | | | | | | | | | | | | | | | | | | | | | | | | | | | | | | | | | | | | | | | | | | | | | | | | | | | | | | | | | | | | | | | | | | | | | | | | | | | | | | | | | | | | | | | | | | | | | | | | | | | | | | | | | | | | | | | | | | | | | | | | | | | | | | | | | | | | | | | | | | | | | | | | | | | | | | | | | | | | | | | | | | | | | | | | | | | | | | | | | | |
| __ 1 9 | 90 | __ 3 9 | 22.5 | __ 5 9 | 5.6 | | | | | | | | | | | | | | | | | | | | | | | | | | | | | | | | | | | | | | | | | | | | | | | | | | | | | | | | | | | | | | | | | | | | | | | | | | | | | | | | | | | | | | | | | | | | | | | | | | | | | | | | | | | | | | | | | | | | | | | | | | | | | | | | | | | | | | | | | | | | | | | | | | | | | | | | | | | | | | | | | | | | | | | | | | | | | | | | | | | | | | | | | | | | | | | | | | | |
| __ 1 A | 86 | __ 3 A | 21.6 | __ 5 A | 5.4 | | | | | | | | | | | | | | | | | | | | | | | | | | | | | | | | | | | | | | | | | | | | | | | | | | | | | | | | | | | | | | | | | | | | | | | | | | | | | | | | | | | | | | | | | | | | | | | | | | | | | | | | | | | | | | | | | | | | | | | | | | | | | | | | | | | | | | | | | | | | | | | | | | | | | | | | | | | | | | | | | | | | | | | | | | | | | | | | | | | | | | | | | | | | | | | | | | | |
| __ 1 B | 83 | __ 3 B | 20.8 | __ 5 B | 5.2 | | | | | | | | | | | | | | | | | | | | | | | | | | | | | | | | | | | | | | | | | | | | | | | | | | | | | | | | | | | | | | | | | | | | | | | | | | | | | | | | | | | | | | | | | | | | | | | | | | | | | | | | | | | | | | | | | | | | | | | | | | | | | | | | | | | | | | | | | | | | | | | | | | | | | | | | | | | | | | | | | | | | | | | | | | | | | | | | | | | | | | | | | | | | | | | | | | | |
| __ 1 C | 80 | __ 3 C | 20.1 | __ 5 C | 5.0 | | | | | | | | | | | | | | | | | | | | | | | | | | | | | | | | | | | | | | | | | | | | | | | | | | | | | | | | | | | | | | | | | | | | | | | | | | | | | | | | | | | | | | | | | | | | | | | | | | | | | | | | | | | | | | | | | | | | | | | | | | | | | | | | | | | | | | | | | | | | | | | | | | | | | | | | | | | | | | | | | | | | | | | | | | | | | | | | | | | | | | | | | | | | | | | | | | | |
| __ 1 D | 77 | __ 3 D | 19.4 | __ 5 D | 4.9 | | | | | | | | | | | | | | | | | | | | | | | | | | | | | | | | | | | | | | | | | | | | | | | | | | | | | | | | | | | | | | | | | | | | | | | | | | | | | | | | | | | | | | | | | | | | | | | | | | | | | | | | | | | | | | | | | | | | | | | | | | | | | | | | | | | | | | | | | | | | | | | | | | | | | | | | | | | | | | | | | | | | | | | | | | | | | | | | | | | | | | | | | | | | | | | | | | | |
| __ 1 E | 75 | __ 3 E | 18.8 | __ 5 E | 4.7 | | | | | | | | | | | | | | | | | | | | | | | | | | | | | | | | | | | | | | | | | | | | | | | | | | | | | | | | | | | | | | | | | | | | | | | | | | | | | | | | | | | | | | | | | | | | | | | | | | | | | | | | | | | | | | | | | | | | | | | | | | | | | | | | | | | | | | | | | | | | | | | | | | | | | | | | | | | | | | | | | | | | | | | | | | | | | | | | | | | | | | | | | | | | | | | | | | | |
| __ 1 F | 72 | __ 3 F | 18.2 | __ 5 F | 4.5 | | | | | | | | | | | | | | | | | | | | | | | | | | | | | | | | | | | | | | | | | | | | | | | | | | | | | | | | | | | | | | | | | | | | | | | | | | | | | | | | | | | | | | | | | | | | | | | | | | | | | | | | | | | | | | | | | | | | | | | | | | | | | | | | | | | | | | | | | | | | | | | | | | | | | | | | | | | | | | | | | | | | | | | | | | | | | | | | | | | | | | | | | | | | | | | | | | | |

5. PARAMETERS

| No. | Symbol | Name and function | Initial value [unit] | Setting range | Each/ Common | | | | | | | | | | | | | | | | | | | | | | | | | | | | | | | | | | | | |
|---------------|---------------------------------------------------------------------------------------------------|-------------------------------------------------------------------------------------------------------------------------------------------------------------------------------------------------------------------------------------------------------------------------------------------------------------------------------------------------------------------------------------------------------------------------------------------------------------------------------------------------------------------------------------------------------------------------------------------------------------------------------------------------------------------------------------------------------------------------------------------------------------------------------------------|----------------------|---------------|---------------|------------|-------------------------------------------------------------------------------|-------|---------|-------------------------------------------------------------------------|-------|---------|---------------------------------------------------------------------------------------------------|------|---------|--------------------------|-------|------------------------------------|-------|-------|-------|------|-------|-------|-------|------|-------|-------|-------|------|-------|------|-------|------|-------|------|-------|------|------------------------------------|--|------|
| PB45 | CNHF | <p>Table 5.6 Notch depth selection</p> <table border="1"> <thead> <tr> <th>Setting value</th> <th>Depth [dB]</th> <th>Setting value</th> <th>Depth [dB]</th> </tr> </thead> <tbody> <tr> <td>_ 0 _</td> <td>-40.0</td> <td>_ 8 _</td> <td>-6.0</td> </tr> <tr> <td>_ 1 _</td> <td>-24.1</td> <td>_ 9 _</td> <td>-5.0</td> </tr> <tr> <td>_ 2 _</td> <td>-18.1</td> <td>_ A _</td> <td>-4.1</td> </tr> <tr> <td>_ 3 _</td> <td>-14.5</td> <td>_ B _</td> <td>-3.3</td> </tr> <tr> <td>_ 4 _</td> <td>-12.0</td> <td>_ C _</td> <td>-2.5</td> </tr> <tr> <td>_ 5 _</td> <td>-10.1</td> <td>_ D _</td> <td>-1.8</td> </tr> <tr> <td>_ 6 _</td> <td>-8.5</td> <td>_ E _</td> <td>-1.2</td> </tr> <tr> <td>_ 7 _</td> <td>-7.2</td> <td>_ F _</td> <td>-0.6</td> </tr> </tbody> </table> | Setting value | Depth [dB] | Setting value | Depth [dB] | _ 0 _ | -40.0 | _ 8 _ | -6.0 | _ 1 _ | -24.1 | _ 9 _ | -5.0 | _ 2 _ | -18.1 | _ A _ | -4.1 | _ 3 _ | -14.5 | _ B _ | -3.3 | _ 4 _ | -12.0 | _ C _ | -2.5 | _ 5 _ | -10.1 | _ D _ | -1.8 | _ 6 _ | -8.5 | _ E _ | -1.2 | _ 7 _ | -7.2 | _ F _ | -0.6 | Refer to Name and function column. | | Each |
| Setting value | Depth [dB] | Setting value | Depth [dB] | | | | | | | | | | | | | | | | | | | | | | | | | | | | | | | | | | | | | | |
| _ 0 _ | -40.0 | _ 8 _ | -6.0 | | | | | | | | | | | | | | | | | | | | | | | | | | | | | | | | | | | | | | |
| _ 1 _ | -24.1 | _ 9 _ | -5.0 | | | | | | | | | | | | | | | | | | | | | | | | | | | | | | | | | | | | | | |
| _ 2 _ | -18.1 | _ A _ | -4.1 | | | | | | | | | | | | | | | | | | | | | | | | | | | | | | | | | | | | | | |
| _ 3 _ | -14.5 | _ B _ | -3.3 | | | | | | | | | | | | | | | | | | | | | | | | | | | | | | | | | | | | | | |
| _ 4 _ | -12.0 | _ C _ | -2.5 | | | | | | | | | | | | | | | | | | | | | | | | | | | | | | | | | | | | | | |
| _ 5 _ | -10.1 | _ D _ | -1.8 | | | | | | | | | | | | | | | | | | | | | | | | | | | | | | | | | | | | | | |
| _ 6 _ | -8.5 | _ E _ | -1.2 | | | | | | | | | | | | | | | | | | | | | | | | | | | | | | | | | | | | | | |
| _ 7 _ | -7.2 | _ F _ | -0.6 | | | | | | | | | | | | | | | | | | | | | | | | | | | | | | | | | | | | | | |
| PB46 | NH3 | <p>Machine resonance suppression filter 3</p> <p>Set the notch frequency of the machine resonance suppression filter 3.</p> <p>To enable the setting value, select "Enabled (_ _ _ 1)" of "Machine resonance suppression filter 3 selection" in [Pr. PB47].</p> | 4500 [Hz] | 10 to 4500 | Each | | | | | | | | | | | | | | | | | | | | | | | | | | | | | | | | | | | | |
| PB47 | NHQ3 | <p>Notch shape selection 3</p> <p>Set the shape of the machine resonance suppression filter 3.</p> <table border="1"> <thead> <tr> <th>Setting digit</th> <th>Explanation</th> <th>Initial value</th> </tr> </thead> <tbody> <tr> <td>_ _ _ x</td> <td>Machine resonance suppression filter 3 selection 0: Disabled 1: Enabled</td> <td>0h</td> </tr> <tr> <td>_ _ x _</td> <td>Notch depth selection 0: -40 dB 1: -14 dB 2: -8 dB 3: -4 dB</td> <td>0h</td> </tr> <tr> <td>_ x _ _</td> <td>Notch width selection 0: $\alpha = 2$ 1: $\alpha = 3$ 2: $\alpha = 4$ 3: $\alpha = 5$</td> <td>0h</td> </tr> <tr> <td>x _ _ _</td> <td>For manufacturer setting</td> <td>0h</td> </tr> </tbody> </table> | Setting digit | Explanation | Initial value | _ _ _ x | Machine resonance suppression filter 3 selection 0: Disabled 1: Enabled | 0h | _ _ x _ | Notch depth selection 0: -40 dB 1: -14 dB 2: -8 dB 3: -4 dB | 0h | _ x _ _ | Notch width selection 0: $\alpha = 2$ 1: $\alpha = 3$ 2: $\alpha = 4$ 3: $\alpha = 5$ | 0h | x _ _ _ | For manufacturer setting | 0h | Refer to Name and function column. | | Each | | | | | | | | | | | | | | | | | | | | | |
| Setting digit | Explanation | Initial value | | | | | | | | | | | | | | | | | | | | | | | | | | | | | | | | | | | | | | | |
| _ _ _ x | Machine resonance suppression filter 3 selection 0: Disabled 1: Enabled | 0h | | | | | | | | | | | | | | | | | | | | | | | | | | | | | | | | | | | | | | | |
| _ _ x _ | Notch depth selection 0: -40 dB 1: -14 dB 2: -8 dB 3: -4 dB | 0h | | | | | | | | | | | | | | | | | | | | | | | | | | | | | | | | | | | | | | | |
| _ x _ _ | Notch width selection 0: $\alpha = 2$ 1: $\alpha = 3$ 2: $\alpha = 4$ 3: $\alpha = 5$ | 0h | | | | | | | | | | | | | | | | | | | | | | | | | | | | | | | | | | | | | | | |
| x _ _ _ | For manufacturer setting | 0h | | | | | | | | | | | | | | | | | | | | | | | | | | | | | | | | | | | | | | | |
| PB48 | NH4 | <p>Machine resonance suppression filter 4</p> <p>Set the notch frequency of the machine resonance suppression filter 4.</p> <p>To enable the setting value, select "Enabled (_ _ _ 1)" of "Machine resonance suppression filter 4 selection" in [Pr. PB49].</p> | 4500 [Hz] | 10 to 4500 | Each | | | | | | | | | | | | | | | | | | | | | | | | | | | | | | | | | | | | |

5. PARAMETERS

| No. | Symbol | Name and function | Initial value [unit] | Setting range | Each/ Common | | | | | | | | | | | | | | | |
|---------------|-------------------------------------------------------------------------------------------------------------------------------------------------------------------------------------------|--------------------------------------------------------------------------------------------------------------------------------------------------------------------------------------------------------------------------------------------------------------------------------------------------------------------------------------------------------------------------------------------------------------------------------------------------------------------------------------------------------------------------------------------------------------------------------------------------------------------------------------------------------------------------------------------------------------------------------------------------------------------------------------------------------------------------------------------------------------------------------------------------------------------------|----------------------|---------------|---------------|------|-------------------------------------------------------------------------------------------------------------------------------------------------------------------------------------------|----|------|-------------------------------------------------------------------------|----|------|---------------------------------------------------------------------------------------------------|----|------|--------------------------|----|------------------------------------|--|------|
| PB49 | NHQ4 | <p>Notch shape selection 4 Set the shape of the machine resonance suppression filter 4.</p> <table border="1"> <thead> <tr> <th>Setting digit</th> <th>Explanation</th> <th>Initial value</th> </tr> </thead> <tbody> <tr> <td>___x</td> <td>Machine resonance suppression filter 4 selection 0: Disabled 1: Enabled When you select "Enabled" of this digit, [Pr. PB17 Shaft resonance suppression filter] is not available.</td> <td>0h</td> </tr> <tr> <td>__x_</td> <td>Notch depth selection 0: -40 dB 1: -14 dB 2: -8 dB 3: -4 dB</td> <td>0h</td> </tr> <tr> <td>_x__</td> <td>Notch width selection 0: $\alpha = 2$ 1: $\alpha = 3$ 2: $\alpha = 4$ 3: $\alpha = 5$</td> <td>0h</td> </tr> <tr> <td>x___</td> <td>For manufacturer setting</td> <td>0h</td> </tr> </tbody> </table> | Setting digit | Explanation | Initial value | ___x | Machine resonance suppression filter 4 selection 0: Disabled 1: Enabled When you select "Enabled" of this digit, [Pr. PB17 Shaft resonance suppression filter] is not available. | 0h | __x_ | Notch depth selection 0: -40 dB 1: -14 dB 2: -8 dB 3: -4 dB | 0h | _x__ | Notch width selection 0: $\alpha = 2$ 1: $\alpha = 3$ 2: $\alpha = 4$ 3: $\alpha = 5$ | 0h | x___ | For manufacturer setting | 0h | Refer to Name and function column. | | Each |
| Setting digit | Explanation | Initial value | | | | | | | | | | | | | | | | | | |
| ___x | Machine resonance suppression filter 4 selection 0: Disabled 1: Enabled When you select "Enabled" of this digit, [Pr. PB17 Shaft resonance suppression filter] is not available. | 0h | | | | | | | | | | | | | | | | | | |
| __x_ | Notch depth selection 0: -40 dB 1: -14 dB 2: -8 dB 3: -4 dB | 0h | | | | | | | | | | | | | | | | | | |
| _x__ | Notch width selection 0: $\alpha = 2$ 1: $\alpha = 3$ 2: $\alpha = 4$ 3: $\alpha = 5$ | 0h | | | | | | | | | | | | | | | | | | |
| x___ | For manufacturer setting | 0h | | | | | | | | | | | | | | | | | | |
| PB50 | NH5 | <p>Machine resonance suppression filter 5 Set the notch frequency of the machine resonance suppression filter 5. To enable the setting value, select "Enabled (___1)" of "Machine resonance suppression filter 5 selection" in [Pr. PB51].</p> | 4500 [Hz] | 10 to 4500 | Each | | | | | | | | | | | | | | | |
| PB51 | NHQ5 | <p>Notch shape selection 5 Set the shape of the machine resonance suppression filter 5. When you select "Enabled (___1)" of "Robust filter selection" in [Pr. PE41], the machine resonance suppression filter 5 is not available.</p> <table border="1"> <thead> <tr> <th>Setting digit</th> <th>Explanation</th> <th>Initial value</th> </tr> </thead> <tbody> <tr> <td>___x</td> <td>Machine resonance suppression filter 5 selection 0: Disabled 1: Enabled</td> <td>0h</td> </tr> <tr> <td>__x_</td> <td>Notch depth selection 0: -40 dB 1: -14 dB 2: -8 dB 3: -4 dB</td> <td>0h</td> </tr> <tr> <td>_x__</td> <td>Notch width selection 0: $\alpha = 2$ 1: $\alpha = 3$ 2: $\alpha = 4$ 3: $\alpha = 5$</td> <td>0h</td> </tr> <tr> <td>x___</td> <td>For manufacturer setting</td> <td>0h</td> </tr> </tbody> </table> | Setting digit | Explanation | Initial value | ___x | Machine resonance suppression filter 5 selection 0: Disabled 1: Enabled | 0h | __x_ | Notch depth selection 0: -40 dB 1: -14 dB 2: -8 dB 3: -4 dB | 0h | _x__ | Notch width selection 0: $\alpha = 2$ 1: $\alpha = 3$ 2: $\alpha = 4$ 3: $\alpha = 5$ | 0h | x___ | For manufacturer setting | 0h | Refer to Name and function column. | | Each |
| Setting digit | Explanation | Initial value | | | | | | | | | | | | | | | | | | |
| ___x | Machine resonance suppression filter 5 selection 0: Disabled 1: Enabled | 0h | | | | | | | | | | | | | | | | | | |
| __x_ | Notch depth selection 0: -40 dB 1: -14 dB 2: -8 dB 3: -4 dB | 0h | | | | | | | | | | | | | | | | | | |
| _x__ | Notch width selection 0: $\alpha = 2$ 1: $\alpha = 3$ 2: $\alpha = 4$ 3: $\alpha = 5$ | 0h | | | | | | | | | | | | | | | | | | |
| x___ | For manufacturer setting | 0h | | | | | | | | | | | | | | | | | | |
| PB52 | VRF21 | <p>Vibration suppression control 2 - Vibration frequency Set the vibration frequency for vibration suppression control 2 to suppress low-frequency machine vibration. To enable the setting value, set "Vibration suppression mode selection" to "3 inertia mode (___1)" in [Pr. PA24]. When "Vibration suppression control 2 tuning mode selection" is set to "Automatic setting (___1)" in [Pr. PB02], this parameter will be set automatically. When "Manual setting (___2)" is selected, the setting written to the parameter is used. The setting range of this parameter varies, depending on the value in [Pr. PB07]. If a value out of the range is set, the vibration suppression control will be disabled. Refer to section 7.1.5 for details.</p> | 100.0 [Hz] | 0.1 to 300.0 | Each | | | | | | | | | | | | | | | |

5. PARAMETERS

| No. | Symbol | Name and function | Initial value [unit] | Setting range | Each/ Common |
|------|--------|------------------------------------------------------------------------------------------------------------------------------------------------------------------------------------------------------------------------------------------------------------------------------------------------------------------------------------------------------------------------------------------------------------------------------------------------------------------------------------------------------------------------------------------------------------------------------------------------------------------------------------------------------------------------------------------------------------------------------------------------------------------------------------------------------------------------------------------------------------------------------------------------------------------------------------------------------------------------------------------------|----------------------|---------------|--------------|
| PB53 | VRF22 | <p>Vibration suppression control 2 - Resonance frequency</p> <p>Set the resonance frequency for vibration suppression control 2 to suppress low-frequency machine vibration.</p> <p>To enable the setting value, set "Vibration suppression mode selection" to "3 inertia mode (_ _ _ 1)" in [Pr. PA24].</p> <p>When "Vibration suppression control 2 tuning mode selection" is set to "Automatic setting (_ _ 1 _)" in [Pr. PB02], this parameter will be set automatically. When "Manual setting (_ _ 2 _)" is selected, the setting written to the parameter is used.</p> <p>The setting range of this parameter varies, depending on the value in [Pr. PB07]. If a value out of the range is set, the vibration suppression control will be disabled. Refer to section 7.1.5 for details.</p> | 100.0 [Hz] | 0.1 to 300.0 | Each |
| PB54 | VRF23 | <p>Vibration suppression control 2 - Vibration frequency damping</p> <p>Set a damping of the vibration frequency for vibration suppression control 2 to suppress low-frequency machine vibration.</p> <p>To enable the setting value, set "Vibration suppression mode selection" to "3 inertia mode (_ _ _ 1)" in [Pr. PA24].</p> <p>When "Vibration suppression control 2 tuning mode selection" is set to "Automatic setting (_ _ 1 _)" in [Pr. PB02], this parameter will be set automatically. When "Manual setting (_ _ 2 _)" is selected, the setting written to the parameter is used. Refer to section 7.1.5 for details.</p> | 0.00 | 0.00 to 0.30 | Each |
| PB55 | VRF24 | <p>Vibration suppression control 2 - Resonance frequency damping</p> <p>Set a damping of the resonance frequency for vibration suppression control 2 to suppress low-frequency machine vibration.</p> <p>To enable the setting value, set "Vibration suppression mode selection" to "3 inertia mode (_ _ _ 1)" in [Pr. PA24].</p> <p>When "Vibration suppression control 2 tuning mode selection" is set to "Automatic setting (_ _ 1 _)" in [Pr. PB02], this parameter will be set automatically. When "Manual setting (_ _ 2 _)" is selected, the setting written to the parameter is used. Refer to section 7.1.5 for details.</p> | 0.00 | 0.00 to 0.30 | Each |
| PB56 | VRF21B | <p>Vibration suppression control 2 - Vibration frequency after gain switching</p> <p>Set the vibration frequency for vibration suppression control 2 when the gain switching is enabled.</p> <p>When you set a value less than 0.1 Hz, the value will be the same as [Pr. PB52].</p> <p>To enable this, select "3 inertia mode (_ _ _ 1)" of "Vibration suppression mode selection" in [Pr. PA24].</p> <p>This parameter will be enabled only when the following conditions are fulfilled.</p> <ul style="list-style-type: none"> • "Gain adjustment mode selection" in [Pr. PA08] is "Manual mode (_ _ _ 3)". • "Vibration suppression control 2 tuning mode selection" in [Pr. PB02] is "Manual setting (_ _ 2 _)". • "Gain switching selection" in [Pr. PB26] is "Control command from controller is enabled (_ _ _ 1)". <p>Switching during driving may cause a shock. Be sure to switch them after the servo motor or linear servo motor stops.</p> | 0.0 [Hz] | 0.0 to 300.0 | Each |
| PB57 | VRF22B | <p>Vibration suppression control 2 - Resonance frequency after gain switching</p> <p>Set the resonance frequency for vibration suppression control 2 when the gain switching is enabled.</p> <p>When you set a value less than 0.1 Hz, the value will be the same as [Pr. PB53].</p> <p>To enable this, select "3 inertia mode (_ _ _ 1)" of "Vibration suppression mode selection" in [Pr. PA24].</p> <p>This parameter will be enabled only when the following conditions are fulfilled.</p> <ul style="list-style-type: none"> • "Gain adjustment mode selection" in [Pr. PA08] is "Manual mode (_ _ _ 3)". • "Vibration suppression control 2 tuning mode selection" in [Pr. PB02] is "Manual setting (_ _ 2 _)". • "Gain switching selection" in [Pr. PB26] is "Control command from controller is enabled (_ _ _ 1)". <p>Switching during driving may cause a shock. Be sure to switch them after the servo motor or linear servo motor stops.</p> | 0.0 [Hz] | 0.0 to 300.0 | Each |

5. PARAMETERS

| No. | Symbol | Name and function | Initial value [unit] | Setting range | Each/ Common |
|------|--------|----------------------------------------------------------------------------------------------------------------------------------------------------------------------------------------------------------------------------------------------------------------------------------------------------------------------------------------------------------------------------------------------------------------------------------------------------------------------------------------------------------------------------------------------------------------------------------------------------------------------------------------------------------------------------------------------------------------------------------------------------------------------------------------------------------------------------------------------------------------------------------------------------------------------------|----------------------|---------------|--------------|
| PB58 | VRF23B | <p>Vibration suppression control 2 - Vibration frequency damping after gain switching</p> <p>Set a damping of the vibration frequency for vibration suppression control 2 when the gain switching is enabled.</p> <p>To enable this, select "3 inertia mode (_ _ _ 1)" of "Vibration suppression mode selection" in [Pr. PA24].</p> <p>This parameter will be enabled only when the following conditions are fulfilled.</p> <ul style="list-style-type: none"> • "Gain adjustment mode selection" in [Pr. PA08] is "Manual mode (_ _ _ 3)". • "Vibration suppression control 2 tuning mode selection" in [Pr. PB02] is "Manual setting (_ _ 2 _)". • "Gain switching selection" in [Pr. PB26] is "Control command from controller is enabled (_ _ _ 1)". <p>Switching during driving may cause a shock. Be sure to switch them after the servo motor or linear servo motor stops.</p> | 0.00 | 0.00 to 0.30 | Each |
| PB59 | VRF24B | <p>Vibration suppression control 2 - Resonance frequency damping after gain switching</p> <p>Set a damping of the resonance frequency for vibration suppression control 2 when the gain switching is enabled.</p> <p>To enable this, select "3 inertia mode (_ _ _ 1)" of "Vibration suppression mode selection" in [Pr. PA24].</p> <p>This parameter will be enabled only when the following conditions are fulfilled.</p> <ul style="list-style-type: none"> • "Gain adjustment mode selection" in [Pr. PA08] is "Manual mode (_ _ _ 3)". • "Vibration suppression control 2 tuning mode selection" in [Pr. PB02] is "Manual setting (_ _ 2 _)". • "Gain switching selection" in [Pr. PB26] is "Control command from controller is enabled (_ _ _ 1)". <p>Switching during driving may cause a shock. Be sure to switch them after the servo motor or linear servo motor stops.</p> | 0.00 | 0.00 to 0.30 | Each |
| PB60 | PG1B | <p>Model loop gain after gain switching</p> <p>Set the model loop gain when the gain switching is enabled.</p> <p>When you set a value less than 1.0 rad/s, the value will be the same as [Pr. PB07].</p> <p>This parameter will be enabled only when the following conditions are fulfilled.</p> <ul style="list-style-type: none"> • "Gain adjustment mode selection" in [Pr. PA08] is "Manual mode (_ _ _ 3)". • "Gain switching selection" in [Pr. PB26] is "Control command from controller is enabled (_ _ _ 1)". <p>Switching during driving may cause a shock. Be sure to switch them after the servo motor or linear servo motor stops.</p> | 0.0 [rad/s] | 0.0 to 2000.0 | Each |

5. PARAMETERS

5.2.3 Extension setting parameters ([Pr. PC__])

| No. | Symbol | Name and function | Initial value [unit] | Setting range | Each/ Common | | | | | | | | | | | | | | | | | | | | | | | | | |
|---------------|-----------------------------------------------------------------------------------------------------------------------------------------------------------------------------------------------------------------------------------------------------------------------------------------------------------------------------------------------------------------------------------------------------------------------------------------------------------------------------------------------------------------------------------------------------------------------------------------------------------------------------------------------------------------------------------------------------------------------------------------------------------------------------------------------------------------------------------------------------------------------------------------|---------------------------------------------------------------------------------------------------------------------------------------------------------------------------------------------------------------------------------------------------------------------------------------------------------------------------------------------------------------------------------------------------------------------------------------------------------------------------------------------------------------------------------------------------------------------------------------------------------------------------------------------------------------------------------------------------------------------------------------------------------------------------------------------------------------------------------------------------------------------------------------------------------------------------------------------------------------------------------------------------------------------------------------------------------------------------------------------------------------------------------------------------------------------------------------------------------------------------------------------------------------------------------------------------------------------------------------------------------------------------------------------------------------------------------------------------------------------------------------------------------------------------------------------------------------------------------------------------------------------------------------------------------------------------------------------------------------------------------------------------------------------------------------------------------------------------------------------------------------------------------------------------------------------------------------------------------------------------------------------------------------------------------------------------------------------------------------------------------------------------------------------------------------------------------------------------------------------------------------------------------------------------------------------------------------------------------------------------------------------------------------------------------------------------------------------------------------------------------------------------------------------------------------------------------------------------------------------------------------------------------------------------------------------------------------------------------|------------------------------------------------------------------------|---------------|---------------------------|--------------------------|-----------------------------------------------------------------------------------------------------------------------------------------------------------------------------------------------------------------------------------------------------------------------------------------------------------------------------------------------------------------------------------------------------------------------------------------------------------------------------------------------------------------------------------------------------------------------------------------------------------------------------------------------------------------------------------------------------------------------------------------------------------------------------------------------------------------------------------------------------------------------------------------|---------------|------------------------------------------------------------------------|---|---------------------------|--------------------------|----|--|--|---|--|--|----|---------|-----------------------------------------------------------------------------------------------------------------------------------------------------------------------------------------------------------------------------------------------------------------------------------------------------------------------------------------------------------------------------------------|----|---------|--------------------------------------------------------------------------------------------------------------------------------------------------------------------------------------------------------------------------------------------------------------------------------------------------------------------------------------------------------------------------------------------------------------------------------------------------------------------------------------------------------------------------------|----|---------|--------------------------|----|------------------------------------|------|
| PC01 | ERZ | <p>Error excessive alarm level</p> <p>Set an error excessive alarm level.</p> <p>Set this per rev. for rotary servo motors and direct drive motors. Setting "0" will be 3 rev. Setting over 200 rev will be clamped with 200 rev.</p> <p>Set this per mm for linear servo motors. Setting "0" will be 100 mm.</p> <p>Note. Setting can be changed in [Pr. PC06].</p> | 0 [rev]/ [mm] (Note) | 0 to 1000 | Each | | | | | | | | | | | | | | | | | | | | | | | | | |
| PC02 | MBR | <p>Electromagnetic brake sequence output</p> <p>Set a delay time between MBR (Electromagnetic brake interlock) and the base drive circuit is shut-off.</p> | 0 [ms] | 0 to 1000 | Each | | | | | | | | | | | | | | | | | | | | | | | | | |
| PC03 | *ENRS | <p>Encoder output pulse selection</p> <p>Select an encoder pulse direction and encoder output pulse setting. This parameter is not available with C-axis.</p> <table border="1" style="width: 100%; border-collapse: collapse;"> <thead> <tr> <th style="width: 15%;">Setting digit</th> <th style="width: 65%;">Explanation</th> <th style="width: 20%;">Initial value</th> </tr> </thead> <tbody> <tr> <td style="text-align: center;">_ _ _ x</td> <td> <p>Encoder output pulse phase selection</p> <p>0: Increasing A-phase 90° in CCW or positive direction</p> <p>1: Increasing A-phase 90° in CW or negative direction</p> <table border="1" style="width: 100%; border-collapse: collapse; margin: 10px 0;"> <thead> <tr> <th rowspan="2" style="width: 10%;">Setting value</th> <th colspan="2" style="text-align: center;">Servo motor rotation direction/ linear servo motor travel direction</th> </tr> <tr> <th style="width: 45%;">CCW or positive direction</th> <th style="width: 45%;">CW or negative direction</th> </tr> </thead> <tbody> <tr> <td style="text-align: center;">0</td> <td style="text-align: center;"> </td> <td style="text-align: center;"> </td> </tr> <tr> <td style="text-align: center;">1</td> <td style="text-align: center;"> </td> <td style="text-align: center;"> </td> </tr> </tbody> </table> </td> <td style="text-align: center;">0h</td> </tr> <tr> <td style="text-align: center;">_ _ x _</td> <td> <p>Encoder output pulse setting selection</p> <p>0: Output pulse setting When "_ 1 0_" is set to this parameter, [AL. 37 Parameter error] will occur.</p> <p>1: Division ratio setting</p> <p>3: A/B-phase pulse electronic gear setting</p> <p>For linear servo motors, selecting "0" will output as division ratio setting because the output pulse setting is not available.</p> </td> <td style="text-align: center;">0h</td> </tr> <tr> <td style="text-align: center;">_ x _ _</td> <td> <p>Selection of the encoders for encoder output pulse</p> <p>Select an encoder used the encoder output pulses which the servo amplifier outputs.</p> <p>0: Servo motor encoder</p> <p>1: Load-side encoder</p> <p>When "_ 1 0_" is set to this parameter, [AL. 37 Parameter error] will occur.</p> <p>Use [Pr. PA16] only in the fully closed loop system.</p> <p>Selecting "1" in other than fully closed loop system or standard control system (scale measurement function: enabled) triggers [AL. 37 Parameter error].</p> </td> <td style="text-align: center;">0h</td> </tr> <tr> <td style="text-align: center;">x _ _ _</td> <td>For manufacturer setting</td> <td style="text-align: center;">0h</td> </tr> </tbody> </table> | Setting digit | Explanation | Initial value | _ _ _ x | <p>Encoder output pulse phase selection</p> <p>0: Increasing A-phase 90° in CCW or positive direction</p> <p>1: Increasing A-phase 90° in CW or negative direction</p> <table border="1" style="width: 100%; border-collapse: collapse; margin: 10px 0;"> <thead> <tr> <th rowspan="2" style="width: 10%;">Setting value</th> <th colspan="2" style="text-align: center;">Servo motor rotation direction/ linear servo motor travel direction</th> </tr> <tr> <th style="width: 45%;">CCW or positive direction</th> <th style="width: 45%;">CW or negative direction</th> </tr> </thead> <tbody> <tr> <td style="text-align: center;">0</td> <td style="text-align: center;"> </td> <td style="text-align: center;"> </td> </tr> <tr> <td style="text-align: center;">1</td> <td style="text-align: center;"> </td> <td style="text-align: center;"> </td> </tr> </tbody> </table> | Setting value | Servo motor rotation direction/ linear servo motor travel direction | | CCW or positive direction | CW or negative direction | 0 | | | 1 | | | 0h | _ _ x _ | <p>Encoder output pulse setting selection</p> <p>0: Output pulse setting When "_ 1 0_" is set to this parameter, [AL. 37 Parameter error] will occur.</p> <p>1: Division ratio setting</p> <p>3: A/B-phase pulse electronic gear setting</p> <p>For linear servo motors, selecting "0" will output as division ratio setting because the output pulse setting is not available.</p> | 0h | _ x _ _ | <p>Selection of the encoders for encoder output pulse</p> <p>Select an encoder used the encoder output pulses which the servo amplifier outputs.</p> <p>0: Servo motor encoder</p> <p>1: Load-side encoder</p> <p>When "_ 1 0_" is set to this parameter, [AL. 37 Parameter error] will occur.</p> <p>Use [Pr. PA16] only in the fully closed loop system.</p> <p>Selecting "1" in other than fully closed loop system or standard control system (scale measurement function: enabled) triggers [AL. 37 Parameter error].</p> | 0h | x _ _ _ | For manufacturer setting | 0h | Refer to Name and function column. | Each |
| Setting digit | Explanation | Initial value | | | | | | | | | | | | | | | | | | | | | | | | | | | | |
| _ _ _ x | <p>Encoder output pulse phase selection</p> <p>0: Increasing A-phase 90° in CCW or positive direction</p> <p>1: Increasing A-phase 90° in CW or negative direction</p> <table border="1" style="width: 100%; border-collapse: collapse; margin: 10px 0;"> <thead> <tr> <th rowspan="2" style="width: 10%;">Setting value</th> <th colspan="2" style="text-align: center;">Servo motor rotation direction/ linear servo motor travel direction</th> </tr> <tr> <th style="width: 45%;">CCW or positive direction</th> <th style="width: 45%;">CW or negative direction</th> </tr> </thead> <tbody> <tr> <td style="text-align: center;">0</td> <td style="text-align: center;"> </td> <td style="text-align: center;"> </td> </tr> <tr> <td style="text-align: center;">1</td> <td style="text-align: center;"> </td> <td style="text-align: center;"> </td> </tr> </tbody> </table> | Setting value | Servo motor rotation direction/ linear servo motor travel direction | | CCW or positive direction | CW or negative direction | 0 | | | 1 | | | 0h | | | | | | | | | | | | | | | | | |
| Setting value | Servo motor rotation direction/ linear servo motor travel direction | | | | | | | | | | | | | | | | | | | | | | | | | | | | | |
| | CCW or positive direction | CW or negative direction | | | | | | | | | | | | | | | | | | | | | | | | | | | | |
| 0 | | | | | | | | | | | | | | | | | | | | | | | | | | | | | | |
| 1 | | | | | | | | | | | | | | | | | | | | | | | | | | | | | | |
| _ _ x _ | <p>Encoder output pulse setting selection</p> <p>0: Output pulse setting When "_ 1 0_" is set to this parameter, [AL. 37 Parameter error] will occur.</p> <p>1: Division ratio setting</p> <p>3: A/B-phase pulse electronic gear setting</p> <p>For linear servo motors, selecting "0" will output as division ratio setting because the output pulse setting is not available.</p> | 0h | | | | | | | | | | | | | | | | | | | | | | | | | | | | |
| _ x _ _ | <p>Selection of the encoders for encoder output pulse</p> <p>Select an encoder used the encoder output pulses which the servo amplifier outputs.</p> <p>0: Servo motor encoder</p> <p>1: Load-side encoder</p> <p>When "_ 1 0_" is set to this parameter, [AL. 37 Parameter error] will occur.</p> <p>Use [Pr. PA16] only in the fully closed loop system.</p> <p>Selecting "1" in other than fully closed loop system or standard control system (scale measurement function: enabled) triggers [AL. 37 Parameter error].</p> | 0h | | | | | | | | | | | | | | | | | | | | | | | | | | | | |
| x _ _ _ | For manufacturer setting | 0h | | | | | | | | | | | | | | | | | | | | | | | | | | | | |

5. PARAMETERS

| No. | Symbol | Name and function | Initial value [unit] | Setting range | Each/ Common | | | | | | | | | | | | | | | |
|---------------|---------------------------------------------------------------------------------------------------------------------------------------------------------------------------------------------------------------------------------------------------------------------------------------------------------------------------------------------------------------------------------------------------------------------------------------------------------------------------------------------------------------------------------------------------------------------------------------------------------------------------------------------------------------------------------------------------------------------------------------|----------------------------------------------------------------------------------------------------------------------------------------------------------------------------------------------------------------------------------------------------------------------------------------------------------------------------------------------------------------------------------------------------------------------------------------------------------------------------------------------------------------------------------------------------------------------------------------------------------------------------------------------------------------------------------------------------------------------------------------------------------------------------------------------------------------------------------------------------------------------------------------------------------------------------------------------------------------------------------------------------------------------------------------------------------------------------------------------------------------------------------------------------------------------------------------------------------------------------------------------------------------------------------------------------------------------------------------------------------------------------------------------------------------------------------------------------------------------------------------------------------------------------------------------------------------------------------------------------------------------------------------------------------------------------------------------------------------|----------------------|---------------|---------------|------|-------------------------------------------------------------|----|------|--------------------------|------|------|---------------------------------------------------------------------------------------------------------------------------------------------------------------------------------------------------------------------------------------------------------------------------------------------------------------------------------------------------------------------------------------------------------------------------------------------------------------------------------------------------------------------------------------------------------------------------------------------------------------------------------------------------------------------------------------------------------------------------------------|-------------------------------------------------------------------------------------------------------------------------------------------------------------------------------------------------------------------------------------------------------------------------------------------------------------------------------------------------------------------------------------------------------------------------------------------------------|------|----------------------------------------------------------------------------------------------------------------------------------------------------------------------------------------------------------------------------------------------|----|------------------------------------|--|------|
| PC04 | **COP1 | <p>Function selection C-1 Select the encoder cable communication method selection.</p> <table border="1"> <thead> <tr> <th>Setting digit</th> <th>Explanation</th> <th>Initial value</th> </tr> </thead> <tbody> <tr> <td>___x</td> <td rowspan="3">For manufacturer setting</td> <td>0h</td> </tr> <tr> <td>__x_</td> <td>0h</td> </tr> <tr> <td>_x__</td> <td>0h</td> </tr> <tr> <td>x___</td> <td>Encoder cable communication method selection 0: Two-wire type 1: Four-wire type Incorrect setting will result in [AL. 16 Encoder initial communication error 1]. Or [AL. 20 Encoder initial communication error 1] will occur. Setting "1" will trigger [AL. 37] while "Fully closed loop control mode (_ _ 1 _)" is selected in [Pr. PA01]. For MR-J4W2-0303B6 servo amplifiers, this digit cannot be used other than the initial value.</td> <td>0h</td> </tr> </tbody> </table> | Setting digit | Explanation | Initial value | ___x | For manufacturer setting | 0h | __x_ | 0h | _x__ | 0h | x___ | Encoder cable communication method selection 0: Two-wire type 1: Four-wire type Incorrect setting will result in [AL. 16 Encoder initial communication error 1]. Or [AL. 20 Encoder initial communication error 1] will occur. Setting "1" will trigger [AL. 37] while "Fully closed loop control mode (_ _ 1 _)" is selected in [Pr. PA01]. For MR-J4W2-0303B6 servo amplifiers, this digit cannot be used other than the initial value. | 0h | Refer to Name and function column. | | Each | | |
| Setting digit | Explanation | Initial value | | | | | | | | | | | | | | | | | | |
| ___x | For manufacturer setting | 0h | | | | | | | | | | | | | | | | | | |
| __x_ | | 0h | | | | | | | | | | | | | | | | | | |
| _x__ | | 0h | | | | | | | | | | | | | | | | | | |
| x___ | Encoder cable communication method selection 0: Two-wire type 1: Four-wire type Incorrect setting will result in [AL. 16 Encoder initial communication error 1]. Or [AL. 20 Encoder initial communication error 1] will occur. Setting "1" will trigger [AL. 37] while "Fully closed loop control mode (_ _ 1 _)" is selected in [Pr. PA01]. For MR-J4W2-0303B6 servo amplifiers, this digit cannot be used other than the initial value. | 0h | | | | | | | | | | | | | | | | | | |
| PC05 | **COP2 | <p>Function selection C-2 Set the motor-less operation, servo motor main circuit power supply, and [AL. 9B Error excessive warning]. The motor-less operation cannot be used in the fully closed loop control mode, linear servo motor control mode, or DD motor control mode.</p> <table border="1"> <thead> <tr> <th>Setting digit</th> <th>Explanation</th> <th>Initial value</th> </tr> </thead> <tbody> <tr> <td>___x</td> <td>Motor-less operation selection 0: Disabled 1: Enabled</td> <td>0h</td> </tr> <tr> <td>__x_</td> <td>For manufacturer setting</td> <td>0h</td> </tr> <tr> <td>_x__</td> <td>Main circuit power supply selection Select a voltage to be connected to the main circuit power supply with an MR-J4W2-0303B6 servo amplifier. 0: 48 V DC 1: 24 V DC When using 24 V DC for the main circuit power supply, set "1" to this digit. The setting of this digit in the J3 compatibility mode is the same as the MR-J3W-0303BN6 servo amplifier. Set it with [Pr. Po04]. For details, refer to "MR-J3W-0303BN6 MR-J3W-_B Servo Amplifier Instruction Manual". This digit is not available with MR-J4W-_B 200 W or more servo amplifiers. The characteristics of the servo motor vary depending on whether 48 V DC or 24 V DC is used. For details, refer to "Servo Motor Instruction Manual (Vol. 3)".</td> <td>0h</td> </tr> <tr> <td>x___</td> <td>[AL. 9B Error excessive warning] selection 0: [AL. 9B Error excessive warning] is disabled. 1: [AL. 9B Error excessive warning] is enabled. The setting of this digit is used by servo amplifier with software version B4 or later.</td> <td>0h</td> </tr> </tbody> </table> | Setting digit | Explanation | Initial value | ___x | Motor-less operation selection 0: Disabled 1: Enabled | 0h | __x_ | For manufacturer setting | 0h | _x__ | Main circuit power supply selection Select a voltage to be connected to the main circuit power supply with an MR-J4W2-0303B6 servo amplifier. 0: 48 V DC 1: 24 V DC When using 24 V DC for the main circuit power supply, set "1" to this digit. The setting of this digit in the J3 compatibility mode is the same as the MR-J3W-0303BN6 servo amplifier. Set it with [Pr. Po04]. For details, refer to "MR-J3W-0303BN6 MR-J3W-_B Servo Amplifier Instruction Manual". This digit is not available with MR-J4W-_B 200 W or more servo amplifiers. The characteristics of the servo motor vary depending on whether 48 V DC or 24 V DC is used. For details, refer to "Servo Motor Instruction Manual (Vol. 3)". | 0h | x___ | [AL. 9B Error excessive warning] selection 0: [AL. 9B Error excessive warning] is disabled. 1: [AL. 9B Error excessive warning] is enabled. The setting of this digit is used by servo amplifier with software version B4 or later. | 0h | Refer to Name and function column. | | Each |
| Setting digit | Explanation | Initial value | | | | | | | | | | | | | | | | | | |
| ___x | Motor-less operation selection 0: Disabled 1: Enabled | 0h | | | | | | | | | | | | | | | | | | |
| __x_ | For manufacturer setting | 0h | | | | | | | | | | | | | | | | | | |
| _x__ | Main circuit power supply selection Select a voltage to be connected to the main circuit power supply with an MR-J4W2-0303B6 servo amplifier. 0: 48 V DC 1: 24 V DC When using 24 V DC for the main circuit power supply, set "1" to this digit. The setting of this digit in the J3 compatibility mode is the same as the MR-J3W-0303BN6 servo amplifier. Set it with [Pr. Po04]. For details, refer to "MR-J3W-0303BN6 MR-J3W-_B Servo Amplifier Instruction Manual". This digit is not available with MR-J4W-_B 200 W or more servo amplifiers. The characteristics of the servo motor vary depending on whether 48 V DC or 24 V DC is used. For details, refer to "Servo Motor Instruction Manual (Vol. 3)". | 0h | | | | | | | | | | | | | | | | | | |
| x___ | [AL. 9B Error excessive warning] selection 0: [AL. 9B Error excessive warning] is disabled. 1: [AL. 9B Error excessive warning] is enabled. The setting of this digit is used by servo amplifier with software version B4 or later. | 0h | | | | | | | | | | | | | | | | | | |

5. PARAMETERS

| No. | Symbol | Name and function | Initial value [unit] | Setting range | Each/ Common | | | | | | | | | | | | | |
|---------------|----------------------------------------------------------------------------------------------------------------------------------------------------------------------------------|------------------------------------------------------------------------------------------------------------------------------------------------------------------------------------------------------------------------------------------------------------------------------------------------------------------------------------------------------------------------------------------------------------------------------------------------------------------------------------------------------------------------------------------------------------------------------------------------------------------------------------------------------------------------------------------------------------------------------------------------------------------------------------------------------------------------------------------------------------|--------------------------|---------------|---------------|------|--------------------------|----|------|----|------|----|------|----------------------------------------------------------------------------------------------------------------------------------------------------------------------------------|----|------------------------------------|--|------|
| PC06 | *COP3 | <p>Function selection C-3 Select units for error excessive alarm level setting with [Pr. PC01] and for error excessive warning level setting with [Pr. PC38]. The parameter is not available in the speed control mode and torque control mode.</p> <table border="1"> <thead> <tr> <th>Setting digit</th> <th>Explanation</th> <th>Initial value</th> </tr> </thead> <tbody> <tr> <td>___x</td> <td rowspan="3">For manufacturer setting</td> <td>0h</td> </tr> <tr> <td>__x_</td> <td>0h</td> </tr> <tr> <td>_x__</td> <td>0h</td> </tr> <tr> <td>x___</td> <td>Error excessive alarm/error excessive warning level unit selection 0: Per rev or mm 1: Per 0.1 rev or 0.1 mm 2: Per 0.01 rev or 0.01 mm 3: Per 0.001 rev or 0.001 mm</td> <td>0h</td> </tr> </tbody> </table> | Setting digit | Explanation | Initial value | ___x | For manufacturer setting | 0h | __x_ | 0h | _x__ | 0h | x___ | Error excessive alarm/error excessive warning level unit selection 0: Per rev or mm 1: Per 0.1 rev or 0.1 mm 2: Per 0.01 rev or 0.01 mm 3: Per 0.001 rev or 0.001 mm | 0h | Refer to Name and function column. | | Each |
| Setting digit | Explanation | Initial value | | | | | | | | | | | | | | | | |
| ___x | For manufacturer setting | 0h | | | | | | | | | | | | | | | | |
| __x_ | | 0h | | | | | | | | | | | | | | | | |
| _x__ | | 0h | | | | | | | | | | | | | | | | |
| x___ | Error excessive alarm/error excessive warning level unit selection 0: Per rev or mm 1: Per 0.1 rev or 0.1 mm 2: Per 0.01 rev or 0.01 mm 3: Per 0.001 rev or 0.001 mm | 0h | | | | | | | | | | | | | | | | |
| PC07 | ZSP | <p>Zero speed Set an output range of ZSP (Zero speed detection). ZSP (Zero speed detection) has hysteresis of 20 r/min or 20 mm/s.</p> | 50 [r/min]/ [mm/s] | 0 to 10000 | Each | | | | | | | | | | | | | |
| PC08 | OSL | <p>Overspeed alarm detection level Set an overspeed alarm detection level. When you set a value more than "(linear) servo motor maximum speed × 120%", the set value will be clamped. When you set "0", the value of "(linear) servo motor maximum speed × 120%" will be set.</p> | 0 [r/min]/ [mm/s] | 0 to 20000 | Each | | | | | | | | | | | | | |

5. PARAMETERS

| No. | Symbol | Name and function | Initial value [unit] | Setting range | Each/ Common | | | | | | | | | | | | | | | | | | | | | | | | | | | | | | | | | | | | | | | | | | | | | |
|---------------|----------------------------------------------------------------------------------------------------------------|--------------------------------------------------------------------------------------------------------------------------------------------------------------------------------------------------------------------------------------------------------------------------------------------------------------------------------------------------------------------------------------------------------------------------------------------------------------------------------------------------------------------------------------------------------------------------------------------------------------------------------------------------------------------------------------------------------------------------------------------------------------------------------------------------------------------------------------------------------------------------------------------------------------------------------------------------------------------------------------------------------------------------------------------------------------------------------------------------------------------------------------------------------------------------------------------------------------------------------------------------------------------------------------------------------------------------------------------------------------------------------------------------------------------------------------------------------------------------------------------------------------------------------------------------------------------------------------------------------------------------------------------------------------------------------------------------------------------------------------------------------------------------------------------------------------------------------------------------------------------------------------------------------------------------------------------------------------------------------------------------------------------------------------------------------------------------------------------------------------------------------------------------------------------------------------------------------------------------------------------------------------------------------------------------------------------|----------------------|---------------|---------------|--------|------------------------------------------------------------------------|-----|---------|--------------------------|----|---------|----------------------------------------------------------------------------------------------------------------|----|----------------------------------------|--------|--------|-------------------------------------------|--------|---------------------------------|--------|-------------------------------------------|--------|---------------------------------|--------|---------------------------------------------------|--------|---------------------------------------|--------|--------------------------------------------------------------|--------|---------------------------------------------------------------|--------|----------------------------------------------------------------|--------|-----------------------------------------------------------------|--------|------------------------------------------------|--------|--------------------------------------------------|--------|---------------------------------------------------|--------|--------------------------------|--------|-----------------------------------------|--------|------------------------------------------------------|----------------------------------------|--------|
| PC09 | MOD1 | <p>Analog monitor 1 output Select a signal to output to MO1 (Analog monitor 1). Refer to section 18.3.7 (6) (c) for detection point of output selection. The parameter is available with MR-J4W2-0303B6 servo amplifiers.</p> <table border="1"> <thead> <tr> <th>Setting digit</th> <th>Explanation</th> <th>Initial value</th> </tr> </thead> <tbody> <tr> <td>__ x x</td> <td>Analog monitor 1 output selection Refer to table 5.7 for settings.</td> <td>00h</td> </tr> <tr> <td>_ x _ _</td> <td>For manufacturer setting</td> <td>0h</td> </tr> <tr> <td>x _ _ _</td> <td>Analog monitor 1 output axis selection Select an output axis of Analog monitor 1. 0: A-axis 1: B-axis</td> <td>0h</td> </tr> </tbody> </table> <p style="text-align: center;">Table 5.7 Analog monitor setting value</p> <table border="1"> <thead> <tr> <th>Setting value</th> <th>Item</th> </tr> </thead> <tbody> <tr><td>__ 0 0</td><td>Servo motor speed (10 V ± 4 V/max. speed)</td></tr> <tr><td>__ 0 1</td><td>Torque (10 V ± 4 V/max. torque)</td></tr> <tr><td>__ 0 2</td><td>Servo motor speed (10 V + 4 V/max. speed)</td></tr> <tr><td>__ 0 3</td><td>Torque (10 V + 4 V/max. torque)</td></tr> <tr><td>__ 0 4</td><td>Current command (10 V ± 4 V/max. current command)</td></tr> <tr><td>__ 0 5</td><td>Speed command (10 V ± 4 V/max. speed)</td></tr> <tr><td>__ 0 6</td><td>Servo motor-side droop pulses (10 V ± 5 V/100 pulses) (Note)</td></tr> <tr><td>__ 0 7</td><td>Servo motor-side droop pulses (10 V ± 5 V/1000 pulses) (Note)</td></tr> <tr><td>__ 0 8</td><td>Servo motor-side droop pulses (10 V ± 5 V/10000 pulses) (Note)</td></tr> <tr><td>__ 0 9</td><td>Servo motor-side droop pulses (10 V ± 5 V/100000 pulses) (Note)</td></tr> <tr><td>__ 0 A</td><td>Feedback position (10 V ± 5 V/1 Mpulse) (Note)</td></tr> <tr><td>__ 0 B</td><td>Feedback position (10 V ± 5 V/10 Mpulses) (Note)</td></tr> <tr><td>__ 0 C</td><td>Feedback position (10 V ± 5 V/100 Mpulses) (Note)</td></tr> <tr><td>__ 0 D</td><td>Bus voltage (10 V + 5 V/100 V)</td></tr> <tr><td>__ 0 E</td><td>Speed command 2 (10 V ± 4 V/max. speed)</td></tr> <tr><td>__ 1 7</td><td>Internal temperature of encoder (10 V ± 5 V/±128 °C)</td></tr> </tbody> </table> <p>Note. Encoder pulse unit</p> | Setting digit | Explanation | Initial value | __ x x | Analog monitor 1 output selection Refer to table 5.7 for settings. | 00h | _ x _ _ | For manufacturer setting | 0h | x _ _ _ | Analog monitor 1 output axis selection Select an output axis of Analog monitor 1. 0: A-axis 1: B-axis | 0h | Setting value | Item | __ 0 0 | Servo motor speed (10 V ± 4 V/max. speed) | __ 0 1 | Torque (10 V ± 4 V/max. torque) | __ 0 2 | Servo motor speed (10 V + 4 V/max. speed) | __ 0 3 | Torque (10 V + 4 V/max. torque) | __ 0 4 | Current command (10 V ± 4 V/max. current command) | __ 0 5 | Speed command (10 V ± 4 V/max. speed) | __ 0 6 | Servo motor-side droop pulses (10 V ± 5 V/100 pulses) (Note) | __ 0 7 | Servo motor-side droop pulses (10 V ± 5 V/1000 pulses) (Note) | __ 0 8 | Servo motor-side droop pulses (10 V ± 5 V/10000 pulses) (Note) | __ 0 9 | Servo motor-side droop pulses (10 V ± 5 V/100000 pulses) (Note) | __ 0 A | Feedback position (10 V ± 5 V/1 Mpulse) (Note) | __ 0 B | Feedback position (10 V ± 5 V/10 Mpulses) (Note) | __ 0 C | Feedback position (10 V ± 5 V/100 Mpulses) (Note) | __ 0 D | Bus voltage (10 V + 5 V/100 V) | __ 0 E | Speed command 2 (10 V ± 4 V/max. speed) | __ 1 7 | Internal temperature of encoder (10 V ± 5 V/±128 °C) | Refer to the Name and function column. | Common |
| Setting digit | Explanation | Initial value | | | | | | | | | | | | | | | | | | | | | | | | | | | | | | | | | | | | | | | | | | | | | | | | |
| __ x x | Analog monitor 1 output selection Refer to table 5.7 for settings. | 00h | | | | | | | | | | | | | | | | | | | | | | | | | | | | | | | | | | | | | | | | | | | | | | | | |
| _ x _ _ | For manufacturer setting | 0h | | | | | | | | | | | | | | | | | | | | | | | | | | | | | | | | | | | | | | | | | | | | | | | | |
| x _ _ _ | Analog monitor 1 output axis selection Select an output axis of Analog monitor 1. 0: A-axis 1: B-axis | 0h | | | | | | | | | | | | | | | | | | | | | | | | | | | | | | | | | | | | | | | | | | | | | | | | |
| Setting value | Item | | | | | | | | | | | | | | | | | | | | | | | | | | | | | | | | | | | | | | | | | | | | | | | | | |
| __ 0 0 | Servo motor speed (10 V ± 4 V/max. speed) | | | | | | | | | | | | | | | | | | | | | | | | | | | | | | | | | | | | | | | | | | | | | | | | | |
| __ 0 1 | Torque (10 V ± 4 V/max. torque) | | | | | | | | | | | | | | | | | | | | | | | | | | | | | | | | | | | | | | | | | | | | | | | | | |
| __ 0 2 | Servo motor speed (10 V + 4 V/max. speed) | | | | | | | | | | | | | | | | | | | | | | | | | | | | | | | | | | | | | | | | | | | | | | | | | |
| __ 0 3 | Torque (10 V + 4 V/max. torque) | | | | | | | | | | | | | | | | | | | | | | | | | | | | | | | | | | | | | | | | | | | | | | | | | |
| __ 0 4 | Current command (10 V ± 4 V/max. current command) | | | | | | | | | | | | | | | | | | | | | | | | | | | | | | | | | | | | | | | | | | | | | | | | | |
| __ 0 5 | Speed command (10 V ± 4 V/max. speed) | | | | | | | | | | | | | | | | | | | | | | | | | | | | | | | | | | | | | | | | | | | | | | | | | |
| __ 0 6 | Servo motor-side droop pulses (10 V ± 5 V/100 pulses) (Note) | | | | | | | | | | | | | | | | | | | | | | | | | | | | | | | | | | | | | | | | | | | | | | | | | |
| __ 0 7 | Servo motor-side droop pulses (10 V ± 5 V/1000 pulses) (Note) | | | | | | | | | | | | | | | | | | | | | | | | | | | | | | | | | | | | | | | | | | | | | | | | | |
| __ 0 8 | Servo motor-side droop pulses (10 V ± 5 V/10000 pulses) (Note) | | | | | | | | | | | | | | | | | | | | | | | | | | | | | | | | | | | | | | | | | | | | | | | | | |
| __ 0 9 | Servo motor-side droop pulses (10 V ± 5 V/100000 pulses) (Note) | | | | | | | | | | | | | | | | | | | | | | | | | | | | | | | | | | | | | | | | | | | | | | | | | |
| __ 0 A | Feedback position (10 V ± 5 V/1 Mpulse) (Note) | | | | | | | | | | | | | | | | | | | | | | | | | | | | | | | | | | | | | | | | | | | | | | | | | |
| __ 0 B | Feedback position (10 V ± 5 V/10 Mpulses) (Note) | | | | | | | | | | | | | | | | | | | | | | | | | | | | | | | | | | | | | | | | | | | | | | | | | |
| __ 0 C | Feedback position (10 V ± 5 V/100 Mpulses) (Note) | | | | | | | | | | | | | | | | | | | | | | | | | | | | | | | | | | | | | | | | | | | | | | | | | |
| __ 0 D | Bus voltage (10 V + 5 V/100 V) | | | | | | | | | | | | | | | | | | | | | | | | | | | | | | | | | | | | | | | | | | | | | | | | | |
| __ 0 E | Speed command 2 (10 V ± 4 V/max. speed) | | | | | | | | | | | | | | | | | | | | | | | | | | | | | | | | | | | | | | | | | | | | | | | | | |
| __ 1 7 | Internal temperature of encoder (10 V ± 5 V/±128 °C) | | | | | | | | | | | | | | | | | | | | | | | | | | | | | | | | | | | | | | | | | | | | | | | | | |
| PC10 | MOD2 | <p>Analog monitor 2 output Select a signal to output to MO2 (Analog monitor 2). Refer to section 18.3.7 (6) (c) for detection point of output selection. The parameter is available with MR-J4W2-0303B6 servo amplifiers.</p> <table border="1"> <thead> <tr> <th>Setting digit</th> <th>Explanation</th> <th>Initial value</th> </tr> </thead> <tbody> <tr> <td>__ x x</td> <td>Analog monitor 2 output selection Refer to [Pr. PC09] for settings.</td> <td>01h</td> </tr> <tr> <td>_ x _ _</td> <td>For manufacturer setting</td> <td>0h</td> </tr> <tr> <td>x _ _ _</td> <td>Analog monitor 2 output axis selection Select an output axis of Analog monitor 2. 0: A-axis 1: B-axis</td> <td>0h</td> </tr> </tbody> </table> | Setting digit | Explanation | Initial value | __ x x | Analog monitor 2 output selection Refer to [Pr. PC09] for settings. | 01h | _ x _ _ | For manufacturer setting | 0h | x _ _ _ | Analog monitor 2 output axis selection Select an output axis of Analog monitor 2. 0: A-axis 1: B-axis | 0h | Refer to the Name and function column. | Common | | | | | | | | | | | | | | | | | | | | | | | | | | | | | | | | | | |
| Setting digit | Explanation | Initial value | | | | | | | | | | | | | | | | | | | | | | | | | | | | | | | | | | | | | | | | | | | | | | | | |
| __ x x | Analog monitor 2 output selection Refer to [Pr. PC09] for settings. | 01h | | | | | | | | | | | | | | | | | | | | | | | | | | | | | | | | | | | | | | | | | | | | | | | | |
| _ x _ _ | For manufacturer setting | 0h | | | | | | | | | | | | | | | | | | | | | | | | | | | | | | | | | | | | | | | | | | | | | | | | |
| x _ _ _ | Analog monitor 2 output axis selection Select an output axis of Analog monitor 2. 0: A-axis 1: B-axis | 0h | | | | | | | | | | | | | | | | | | | | | | | | | | | | | | | | | | | | | | | | | | | | | | | | |
| PC11 | MO1 | <p>Analog monitor 1 offset Set the offset voltage of MO1 (Analog monitor 1). The parameter is available with MR-J4W2-0303B6 servo amplifiers.</p> | 0 [mV] | -9999 to 9999 | Common | | | | | | | | | | | | | | | | | | | | | | | | | | | | | | | | | | | | | | | | | | | | | |

5. PARAMETERS

| No. | Symbol | Name and function | Initial value [unit] | Setting range | Each/ Common | | | | | | | | | | | | | |
|---------------|---------------------------------------------------------------------------------------------------------------------------------------------------------------------------------------------------------------------------------------------------------------------------------------------------------------------------------------------------------------------------------|--------------------------------------------------------------------------------------------------------------------------------------------------------------------------------------------------------------------------------------------------------------------------------------------------------------------------------------------------------------------------------------------------------------------------------------------------------------------------------------------------------------------------------------------------------------------------------------------------------------------------------------------------------------------------------------------------------------------------------------------------------------------------------------------------------------------------------------------------------------------------------------------------------------------------------------------------------------------------------------------------------------------------|----------------------|---------------|---------------|------|--------------------------------------------------------------------------------------------------------------------------------------------------------------|----|------|---------------------------------------------------------------------------------------------------------------------------------------------------------------------------------------------------------------------------------------------------------------------------------------------------------------------------------------------------------------------------------|------|------|--------------------------|--------------------------------------------------------------------------------------------------------------------------------------|------|------------------------------------|----------------------------------------|------|
| PC12 | MO2 | Analog monitor 2 offset Set the offset voltage of MO2 (Analog monitor 2). The parameter is available with MR-J4W2-0303B6 servo amplifiers. | 0 [mV] | -9999 to 9999 | Common | | | | | | | | | | | | | |
| PC13 | MOSDL | Analog monitor - Feedback position output standard data - Low Set a monitor output standard position (lower 4 digits) for the feedback position for when selecting "Feedback position" for MO1 (Analog monitor 1) and MO2 (Analog monitor 2). Monitor output standard position = [Pr. PC14] setting × 10000 + [Pr. PC13] setting The parameter is available with MR-J4W2-0303B6 servo amplifiers. | 0 [pulse] | -9999 to 9999 | Each | | | | | | | | | | | | | |
| PC14 | MOSDH | Analog monitor - Feedback position output standard data - High Set a monitor output standard position (higher 4 digits) for the feedback position for when selecting "Feedback position" for MO1 (Analog monitor 1) and MO2 (Analog monitor 2). Monitor output standard position = [Pr. PC14] setting × 10000 + [Pr. PC13] setting The parameter is available with MR-J4W2-0303B6 servo amplifiers. | 0 [10000 pulses] | -9999 to 9999 | Each | | | | | | | | | | | | | |
| PC17 | **COP4 | Function selection C-4 Select a home position setting condition. <table border="1" data-bbox="347 842 1155 1317"> <thead> <tr> <th>Setting digit</th> <th>Explanation</th> <th>Initial value</th> </tr> </thead> <tbody> <tr> <td>___x</td> <td>Selection of home position setting condition 0: Need to pass servo motor Z-phase after power on 1: Not need to pass servo motor Z-phase after power on</td> <td>0h</td> </tr> <tr> <td>__x_</td> <td>Linear scale multipoint Z-phase input function selection When two or more reference marks exist during the full stroke of the linear encoder, set "1". 0: Disabled 1: Enabled This parameter setting is used by servo amplifiers with software version A5 or later. For MR-J4W2-0303B6 servo amplifiers, this digit cannot be used other than the initial value.</td> <td>0h</td> </tr> <tr> <td>_x__</td> <td rowspan="2">For manufacturer setting</td> <td>0h</td> </tr> <tr> <td>x___</td> <td>0h</td> </tr> </tbody> </table> | Setting digit | Explanation | Initial value | ___x | Selection of home position setting condition 0: Need to pass servo motor Z-phase after power on 1: Not need to pass servo motor Z-phase after power on | 0h | __x_ | Linear scale multipoint Z-phase input function selection When two or more reference marks exist during the full stroke of the linear encoder, set "1". 0: Disabled 1: Enabled This parameter setting is used by servo amplifiers with software version A5 or later. For MR-J4W2-0303B6 servo amplifiers, this digit cannot be used other than the initial value. | 0h | _x__ | For manufacturer setting | 0h | x___ | 0h | Refer to the Name and function column. | Each |
| Setting digit | Explanation | Initial value | | | | | | | | | | | | | | | | |
| ___x | Selection of home position setting condition 0: Need to pass servo motor Z-phase after power on 1: Not need to pass servo motor Z-phase after power on | 0h | | | | | | | | | | | | | | | | |
| __x_ | Linear scale multipoint Z-phase input function selection When two or more reference marks exist during the full stroke of the linear encoder, set "1". 0: Disabled 1: Enabled This parameter setting is used by servo amplifiers with software version A5 or later. For MR-J4W2-0303B6 servo amplifiers, this digit cannot be used other than the initial value. | 0h | | | | | | | | | | | | | | | | |
| _x__ | For manufacturer setting | 0h | | | | | | | | | | | | | | | | |
| x___ | | 0h | | | | | | | | | | | | | | | | |
| PC18 | *COP5 | Function selection C-5 Select an occurring condition of [AL. E9 Main circuit off warning]. <table border="1" data-bbox="347 1429 1155 1666"> <thead> <tr> <th>Setting digit</th> <th>Explanation</th> <th>Initial value</th> </tr> </thead> <tbody> <tr> <td>___x</td> <td rowspan="3">For manufacturer setting</td> <td>0h</td> </tr> <tr> <td>__x_</td> <td>0h</td> </tr> <tr> <td>_x__</td> <td>0h</td> </tr> <tr> <td>x___</td> <td>[AL. E9 Main circuit off warning] selection 0: Detection with ready-on and servo-on command 1: Detection with servo-on command</td> <td>0h</td> </tr> </tbody> </table> | Setting digit | Explanation | Initial value | ___x | For manufacturer setting | 0h | __x_ | 0h | _x__ | 0h | x___ | [AL. E9 Main circuit off warning] selection 0: Detection with ready-on and servo-on command 1: Detection with servo-on command | 0h | Refer to Name and function column. | Common | |
| Setting digit | Explanation | Initial value | | | | | | | | | | | | | | | | |
| ___x | For manufacturer setting | 0h | | | | | | | | | | | | | | | | |
| __x_ | | 0h | | | | | | | | | | | | | | | | |
| _x__ | | 0h | | | | | | | | | | | | | | | | |
| x___ | [AL. E9 Main circuit off warning] selection 0: Detection with ready-on and servo-on command 1: Detection with servo-on command | 0h | | | | | | | | | | | | | | | | |

5. PARAMETERS

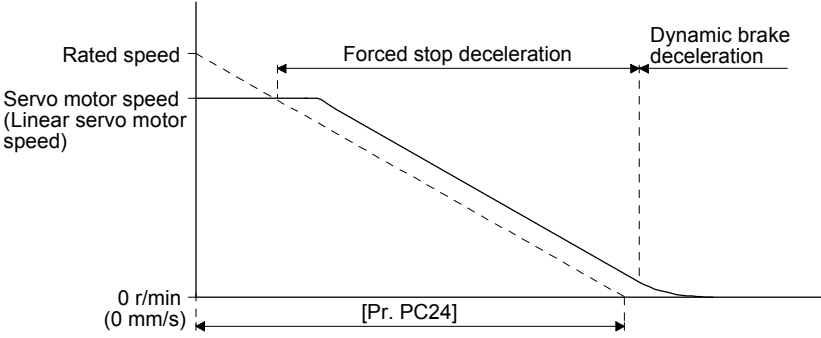
| No. | Symbol | Name and function | Initial value [unit] | Setting range | Each/ Common | | | | | | | | | | | | | | |
|---------------|---------------------------------------------------------------------------------------------------------------------------------------------------------------------------------------------------------------------------------------------------------------------------------------|-------------------------------------------------------------------------------------------------------------------------------------------------------------------------------------------------------------------------------------------------------------------------------------------------------------------------------------------------------------------------------------------------------------------------------------------------------------------------------------------------------------------------------------------------------------------------------------------------------------------------------------------------------------------------------------------------------------------------------------------------------------------------------------------------------------------------------------------------------------------------------------------------------------------------------------------------------------------------------------------------------------------------------------------------------------------------------------------------------------------------------------------|----------------------|---------------|---------------|------|-----------------------------------------------------------------------------------------------------------------------------------------------------------------------------------------------------------------------------|----|------|--------------------------|------|---------------------------------------------------------------------------------------------------------------------------------------------------------------------------------------------------------------------------------------------------------------------------------------|----|------|--------------------------|------------------------------------|------------------------------------|------|--------|
| PC20 | *COP7 | Function selection C-7 Select the detection method of [AL. 10 Undervoltage]. <table border="1" data-bbox="347 405 1153 719"> <thead> <tr> <th>Setting digit</th> <th>Explanation</th> <th>Initial value</th> </tr> </thead> <tbody> <tr> <td>___x</td> <td rowspan="2">For manufacturer setting</td> <td>0h</td> </tr> <tr> <td>__x_</td> <td>0h</td> </tr> <tr> <td>_x__</td> <td> Undervoltage alarm selection Select the alarm/alarm and warning for when the bus voltage drops to the undervoltage alarm level. 0: [AL. 10] regardless of servo motor speed 1: [AL. E9] at servo motor speed 50 r/min (50 mm/s) or less, [AL. 10] at over 50 r/min (50 mm/s) </td> <td>0h</td> </tr> <tr> <td>x___</td> <td>For manufacturer setting</td> <td>0h</td> </tr> </tbody> </table> | Setting digit | Explanation | Initial value | ___x | For manufacturer setting | 0h | __x_ | 0h | _x__ | Undervoltage alarm selection Select the alarm/alarm and warning for when the bus voltage drops to the undervoltage alarm level. 0: [AL. 10] regardless of servo motor speed 1: [AL. E9] at servo motor speed 50 r/min (50 mm/s) or less, [AL. 10] at over 50 r/min (50 mm/s) | 0h | x___ | For manufacturer setting | 0h | Refer to Name and function column. | | Common |
| Setting digit | Explanation | Initial value | | | | | | | | | | | | | | | | | |
| ___x | For manufacturer setting | 0h | | | | | | | | | | | | | | | | | |
| __x_ | | 0h | | | | | | | | | | | | | | | | | |
| _x__ | Undervoltage alarm selection Select the alarm/alarm and warning for when the bus voltage drops to the undervoltage alarm level. 0: [AL. 10] regardless of servo motor speed 1: [AL. E9] at servo motor speed 50 r/min (50 mm/s) or less, [AL. 10] at over 50 r/min (50 mm/s) | 0h | | | | | | | | | | | | | | | | | |
| x___ | For manufacturer setting | 0h | | | | | | | | | | | | | | | | | |
| PC21 | *BPS | Alarm history clear Used to clear the alarm history. <table border="1" data-bbox="347 831 1153 1160"> <thead> <tr> <th>Setting digit</th> <th>Explanation</th> <th>Initial value</th> </tr> </thead> <tbody> <tr> <td>___x</td> <td> Alarm history clear selection 0: Disabled 1: Enabled When "Enabled" is set, the alarm history will be cleared at the next power-on. Once the alarm history is cleared, the setting becomes disabled automatically. </td> <td>0h</td> </tr> <tr> <td>__x_</td> <td rowspan="3">For manufacturer setting</td> <td>0h</td> </tr> <tr> <td>_x__</td> <td>0h</td> </tr> <tr> <td>x___</td> <td>0h</td> </tr> </tbody> </table> | Setting digit | Explanation | Initial value | ___x | Alarm history clear selection 0: Disabled 1: Enabled When "Enabled" is set, the alarm history will be cleared at the next power-on. Once the alarm history is cleared, the setting becomes disabled automatically. | 0h | __x_ | For manufacturer setting | 0h | _x__ | 0h | x___ | 0h | Refer to Name and function column. | | Each | |
| Setting digit | Explanation | Initial value | | | | | | | | | | | | | | | | | |
| ___x | Alarm history clear selection 0: Disabled 1: Enabled When "Enabled" is set, the alarm history will be cleared at the next power-on. Once the alarm history is cleared, the setting becomes disabled automatically. | 0h | | | | | | | | | | | | | | | | | |
| __x_ | For manufacturer setting | 0h | | | | | | | | | | | | | | | | | |
| _x__ | | 0h | | | | | | | | | | | | | | | | | |
| x___ | | 0h | | | | | | | | | | | | | | | | | |
| PC24 | RSBR | Forced stop deceleration time constant Set a deceleration time constant when you use the forced stop deceleration function. Set the time per ms from the rated speed to 0 r/min or 0 mm/s. Setting "0" will be 100 ms.  <p>[Precautions]</p> <ul style="list-style-type: none"> • If the servo motor torque is saturated at the maximum torque during forced stop deceleration because the set time is too short, the time to stop will be longer than the set time constant. • [AL. 50 Overload alarm 1] or [AL. 51 Overload alarm 2] may occur during forced stop deceleration, depending on the set value. • After an alarm that leads to a forced stop deceleration, if an alarm that does not lead to a forced stop deceleration occurs or if the control circuit power supply is cut, dynamic braking will start regardless of the deceleration time constant setting. • Set a longer time than deceleration time of the controller. If a shorter time is set, [AL. 52 Error excessive] may occur. | 100 [ms] | 0 to 20000 | Each | | | | | | | | | | | | | | |

5. PARAMETERS

| No. | Symbol | Name and function | Initial value [unit] | Setting range | Each/ Common | | | | | | | | | | | | | |
|---------------|-----------------------------------------------------------------------------------------------------------------------------------------------------------------------------------------------------------------------|-----------------------------------------------------------------------------------------------------------------------------------------------------------------------------------------------------------------------------------------------------------------------------------------------------------------------------------------------------------------------------------------------------------------------------------------------------------------------------------------------------------------------------------------------------------------------------------------------------------------------------------------------------------------------------------------------------------------------------------------------------------------------------------------------------------------------------------------------------------------------------------------------------------------------------------------------------------------------------------------------------------------------------------------------------------------------------------------------------------------------------------------------------------------------------------------------------------------------------------------------------------------|---------------------------------|-----------------------|---------------|------|-----------------------------------------------------------------------------------------------------------------------------------------------------------------------------------------------------------------------|----|------|--------------------------|------|------|------|-------------------------------------------------------------------------|----|------------------------------------|--|------|
| PC27 | **COP9 | <p>Function selection C-9 Select a polarity of the linear encoder or load-side encoder. This parameter is not available with MR-J4W2-0303B6 servo amplifiers.</p> <table border="1"> <thead> <tr> <th>Setting digit</th> <th>Explanation</th> <th>Initial value</th> </tr> </thead> <tbody> <tr> <td>___x</td> <td>Selection of encoder pulse count polarity 0: Encoder pulse increasing direction in the servo motor CCW or positive direction 1: Encoder pulse decreasing direction in the servo motor CCW or positive direction</td> <td>0h</td> </tr> <tr> <td>__x_</td> <td rowspan="3">For manufacturer setting</td> <td>0h</td> </tr> <tr> <td>_x__</td> <td>0h</td> </tr> <tr> <td>x___</td> <td>0h</td> </tr> </tbody> </table> | Setting digit | Explanation | Initial value | ___x | Selection of encoder pulse count polarity 0: Encoder pulse increasing direction in the servo motor CCW or positive direction 1: Encoder pulse decreasing direction in the servo motor CCW or positive direction | 0h | __x_ | For manufacturer setting | 0h | _x__ | 0h | x___ | 0h | Refer to Name and function column. | | Each |
| Setting digit | Explanation | Initial value | | | | | | | | | | | | | | | | |
| ___x | Selection of encoder pulse count polarity 0: Encoder pulse increasing direction in the servo motor CCW or positive direction 1: Encoder pulse decreasing direction in the servo motor CCW or positive direction | 0h | | | | | | | | | | | | | | | | |
| __x_ | For manufacturer setting | 0h | | | | | | | | | | | | | | | | |
| _x__ | | 0h | | | | | | | | | | | | | | | | |
| x___ | | 0h | | | | | | | | | | | | | | | | |
| PC29 | *COPB | <p>Function selection C-B Select the POL reflection at torque control.</p> <table border="1"> <thead> <tr> <th>Setting digit</th> <th>Explanation</th> <th>Initial value</th> </tr> </thead> <tbody> <tr> <td>___x</td> <td rowspan="3">For manufacturer setting</td> <td>0h</td> </tr> <tr> <td>__x_</td> <td>0h</td> </tr> <tr> <td>_x__</td> <td>0h</td> </tr> <tr> <td>x___</td> <td>POL reflection selection at torque control 0: Enabled 1: Disabled</td> <td>0h</td> </tr> </tbody> </table> | Setting digit | Explanation | Initial value | ___x | For manufacturer setting | 0h | __x_ | 0h | _x__ | 0h | x___ | POL reflection selection at torque control 0: Enabled 1: Disabled | 0h | Refer to Name and function column. | | Each |
| Setting digit | Explanation | Initial value | | | | | | | | | | | | | | | | |
| ___x | For manufacturer setting | 0h | | | | | | | | | | | | | | | | |
| __x_ | | 0h | | | | | | | | | | | | | | | | |
| _x__ | | 0h | | | | | | | | | | | | | | | | |
| x___ | POL reflection selection at torque control 0: Enabled 1: Disabled | 0h | | | | | | | | | | | | | | | | |
| PC31 | RSUP1 | <p>Vertical axis freefall prevention compensation amount Set the compensation amount of the vertical axis freefall prevention function. Set it per servo motor rotation amount. When a positive value is set, compensation is performed to the address increasing direction. When a negative value is set, compensation is performed to the address decreasing direction. The vertical axis freefall prevention function is performed when all of the following conditions are met. 1) Position control mode 2) The value of the parameter is other than "0". 3) The forced stop deceleration function is enabled. 4) Alarm occurs or EM2 turns off when the (linear) servo motor speed is zero speed or less. 5) MBR (Electromagnetic brake interlock) was enabled in [Pr. PD07] to [Pr. PD09], and the base circuit shut-off delay time was set in [Pr. PC02].</p> | 0 [0.0001 rev]/ [0.01 mm] | -25000 to 25000 | Each | | | | | | | | | | | | | |
| PC38 | ERW | <p>Error excessive warning level Set an error excessive warning level. To enable the parameter, select "Enabled (1 ___)" of "[AL. 9B Error excessive warning] selection" in [Pr. PC05]. You can change the setting unit with "Error excessive alarm/error excessive warning level unit selection" in [Pr. PC06]. Set this per rev. for rotary servo motors and direct drive motors. Set this per mm for linear servo motors. Setting "0" will be "1 rev" for rotary servo motors and direct drive motors. Setting over 200 rev will be clamped with 200 rev. It will be "50 mm" for linear servo motors. When an error reaches the set value, [AL. 9B Error excessive warning] will occur. When the error decreases lower than the set value, the warning will be canceled automatically. The minimum pulse width of the warning signal is 100 [ms]. Set as follows.: [Pr. PC38 Error excessive warning level] < [Pr. PC01 Error excessive alarm level] When you set as follows, [AL. 52 Error excessive] will occur earlier than the warning.: [Pr. PC38 Error excessive warning level] ≥ [Pr. PC01 Error excessive alarm level] This parameter is used by servo amplifier with software version B4 or later.</p> | 0 [rev]/ [mm] | 0 to 1000 | Each | | | | | | | | | | | | | |

5. PARAMETERS

5.2.4 I/O setting parameters ([Pr. PD_ _])

| No. | Symbol | Name and function | Initial value [unit] | Setting range | Each/ Common | | | | | | | | | | | | | | | | | | | | | | | | | | | | | | | | | | | | | | | | | | | | | |
|------------------------------------|---------------|-----------------------------------------------------------------------------------------------------------------------------------------------------------------------------------------------------------------------------------------------------------------------------------------------------------------------------------------------------------------------------------------------------------------------------------------------------------------------------------------------------------------------------------------------------------------------------------------------------------------------------------------------------------------------------------------------------------------------------------------------------------------------------------------------------------------------------------------------------------------------------------------------------------------------------------------------------------------------------------------------------------------------------------------------------------------------------------------------------------------------------------------------------------------------------------------------------------------------------------------------------------------------------------------------------------------------------------------------------------------------------------------------------------------------------------------------------------------------------------------------------------------------------------------------------------------------------------------------------------------------------------------------------------------|----------------------|---------------|--------------|---------------|------|------|------|------|-----------------------------------------------------------------|----|--|------|-----------------------------------------------------------------|--|------|--------------------------|--|------|--------------------------|----|--|------|--|----|--|------|--|----|--|------|--|----|-------------|---------------|--|-----|-----|------------------------------------|---|---|------------------------------------|---|--|---|--|---|------------------------------------|------|
| PD02 | *DIA2 | <p>Input signal automatic on selection 2</p> <table border="1"> <thead> <tr> <th colspan="2">Setting digit</th> <th rowspan="2">Explanation</th> <th rowspan="2">Initial value</th> </tr> <tr> <th>HEX.</th> <th>BIN.</th> </tr> </thead> <tbody> <tr> <td>___x</td> <td>___x</td> <td>FLS (Upper stroke limit) selection 0: Disabled 1: Enabled</td> <td rowspan="3">0h</td> </tr> <tr> <td></td> <td>__x_</td> <td>RLS (Lower stroke limit) selection 0: Disabled 1: Enabled</td> </tr> <tr> <td></td> <td>_x__</td> <td>For manufacturer setting</td> </tr> <tr> <td></td> <td>x___</td> <td>For manufacturer setting</td> <td>0h</td> </tr> <tr> <td></td> <td>__x_</td> <td></td> <td>0h</td> </tr> <tr> <td></td> <td>_x__</td> <td></td> <td>0h</td> </tr> <tr> <td></td> <td>x___</td> <td></td> <td>0h</td> </tr> </tbody> </table> <p>Convert the setting value into hexadecimal as follows.</p> <table border="1"> <thead> <tr> <th rowspan="2">Signal name</th> <th colspan="2">Initial value</th> </tr> <tr> <th>BIN</th> <th>HEX</th> </tr> </thead> <tbody> <tr> <td>FLS (Upper stroke limit) selection</td> <td>0</td> <td rowspan="4">0</td> </tr> <tr> <td>RLS (Lower stroke limit) selection</td> <td>0</td> </tr> <tr> <td></td> <td>0</td> </tr> <tr> <td></td> <td>0</td> </tr> </tbody> </table> <p>BIN 0: Disabled (Use for an external input signal.) BIN 1: Automatic on</p> <p>When performing a magnetic pole detection without using FLS (Upper stroke limit) and RLS (Lower stroke limit), you can disable FLS and RLS by setting [Pr. PL08 Linear servo motor/DD motor function selection 3] to "_ 1 _".</p> | Setting digit | | Explanation | Initial value | HEX. | BIN. | ___x | ___x | FLS (Upper stroke limit) selection 0: Disabled 1: Enabled | 0h | | __x_ | RLS (Lower stroke limit) selection 0: Disabled 1: Enabled | | _x__ | For manufacturer setting | | x___ | For manufacturer setting | 0h | | __x_ | | 0h | | _x__ | | 0h | | x___ | | 0h | Signal name | Initial value | | BIN | HEX | FLS (Upper stroke limit) selection | 0 | 0 | RLS (Lower stroke limit) selection | 0 | | 0 | | 0 | Refer to Name and function column. | Each |
| Setting digit | | Explanation | Initial value | | | | | | | | | | | | | | | | | | | | | | | | | | | | | | | | | | | | | | | | | | | | | | | |
| HEX. | BIN. | | | | | | | | | | | | | | | | | | | | | | | | | | | | | | | | | | | | | | | | | | | | | | | | | |
| ___x | ___x | FLS (Upper stroke limit) selection 0: Disabled 1: Enabled | 0h | | | | | | | | | | | | | | | | | | | | | | | | | | | | | | | | | | | | | | | | | | | | | | | |
| | __x_ | RLS (Lower stroke limit) selection 0: Disabled 1: Enabled | | | | | | | | | | | | | | | | | | | | | | | | | | | | | | | | | | | | | | | | | | | | | | | | |
| | _x__ | For manufacturer setting | | | | | | | | | | | | | | | | | | | | | | | | | | | | | | | | | | | | | | | | | | | | | | | | |
| | x___ | For manufacturer setting | 0h | | | | | | | | | | | | | | | | | | | | | | | | | | | | | | | | | | | | | | | | | | | | | | | |
| | __x_ | | 0h | | | | | | | | | | | | | | | | | | | | | | | | | | | | | | | | | | | | | | | | | | | | | | | |
| | _x__ | | 0h | | | | | | | | | | | | | | | | | | | | | | | | | | | | | | | | | | | | | | | | | | | | | | | |
| | x___ | | 0h | | | | | | | | | | | | | | | | | | | | | | | | | | | | | | | | | | | | | | | | | | | | | | | |
| Signal name | Initial value | | | | | | | | | | | | | | | | | | | | | | | | | | | | | | | | | | | | | | | | | | | | | | | | | |
| | BIN | HEX | | | | | | | | | | | | | | | | | | | | | | | | | | | | | | | | | | | | | | | | | | | | | | | | |
| FLS (Upper stroke limit) selection | 0 | 0 | | | | | | | | | | | | | | | | | | | | | | | | | | | | | | | | | | | | | | | | | | | | | | | | |
| RLS (Lower stroke limit) selection | 0 | | | | | | | | | | | | | | | | | | | | | | | | | | | | | | | | | | | | | | | | | | | | | | | | | |
| | 0 | | | | | | | | | | | | | | | | | | | | | | | | | | | | | | | | | | | | | | | | | | | | | | | | | |
| | 0 | | | | | | | | | | | | | | | | | | | | | | | | | | | | | | | | | | | | | | | | | | | | | | | | | |

5. PARAMETERS

| No. | Symbol | Name and function | Initial value [unit] | Setting range | Each/ Common | | | | | | | | | | | | | | | | | | | | | | | | | | | | | | | | | | | | | | | | | | |
|---------------|-----------------------------------------------------------------------------------------------------------------------------------------------------------------------------------------------------------------------------------------------------------------------------------------------------------------------------|-------------------------------------------------------------------------------------------------------------------------------------------------------------------------------------------------------------------------------------------------------------------------------------------------------------------------------------------------------------------------------------------------------------------------------------------------------------------------------------------------------------------------------------------------------------------------------------------------------------------------------------------------------------------------------------------------------------------------------------------------------------------------------------------------------------------------------------------------------------------------------------------------------------------------------------------------------------------------------------------------------------------------------------------------------------------------------------------------------------------------------------------------------------------------------------------------------------------------------------------------------------------------------------------------------------------------------------------------------------------------------------------------------------------------------------------------------------------------------------------------------------------------------------------------------------------------------------------------------------------------------------------------------------------------------------------------------------------------------------------------------------------------------------------------------------------|----------------------|---------------|---------------|--------|--------------------------------------------------------------------|-----|---------|-----------------------------------------------------------------------------------------------------------------------------------------------------------------------------------------------------------------------------------------------------------------------------------------------------------------------------|----|---------|-----------------------------------------------------------------------------|----|------------------------------------|---------------|--------|------------|--------|------------|--------|-------------------|--------|-------------------|--------|---------------------------------------|--------|-----------------------|--------|---------------|--------|------------------------|--------|--------------------|--------|----------------------------|--------|--------------------------------|--------|-----------------------------------------|--------|---------------------------------------|--------|---------------------------|------------------------------------|--|------|
| PD07 | *DO1 | <p>Output device selection 1</p> <p>You can assign any output device to pins CN3-12, CN3-13, and CN3-25. In the initial setting, the following devices are assigned to the pins.</p> <p>CN3-12 pin: MBR-A (Electromagnetic brake interlock for A-axis)</p> <p>CN3-13 pin: MBR-C (Electromagnetic brake interlock for C-axis)</p> <p>CN3-25 pin: MBR-B (Electromagnetic brake interlock for B-axis)</p> <table border="1"> <thead> <tr> <th>Setting digit</th> <th>Explanation</th> <th>Initial value</th> </tr> </thead> <tbody> <tr> <td>__ x x</td> <td>Device selection Refer to table 5.8 for settings.</td> <td>05h</td> </tr> <tr> <td>_ x _ _</td> <td>For manufacturer setting</td> <td>0h</td> </tr> <tr> <td>x _ _ _</td> <td></td> <td>0h</td> </tr> </tbody> </table> <p style="text-align: center;">Table 5.8 Selectable output devices</p> <table border="1"> <thead> <tr> <th>Setting value</th> <th>Output device</th> </tr> </thead> <tbody> <tr><td>__ 0 0</td><td>Always off</td></tr> <tr><td>__ 0 2</td><td>RD (Ready)</td></tr> <tr><td>__ 0 3</td><td>ALM (Malfunction)</td></tr> <tr><td>__ 0 4</td><td>INP (In-position)</td></tr> <tr><td>__ 0 5</td><td>MBR (Electromagnetic brake interlock)</td></tr> <tr><td>__ 0 7</td><td>TLC (Limiting torque)</td></tr> <tr><td>__ 0 8</td><td>WNG (Warning)</td></tr> <tr><td>__ 0 9</td><td>BWNG (Battery warning)</td></tr> <tr><td>__ 0 A</td><td>SA (Speed reached)</td></tr> <tr><td>__ 0 C</td><td>ZSP (Zero speed detection)</td></tr> <tr><td>__ 0 F</td><td>CDPS (Variable gain selection)</td></tr> <tr><td>__ 1 0</td><td>CLDS (During fully closed loop control)</td></tr> <tr><td>__ 1 1</td><td>ABSV (Absolute position undetermined)</td></tr> <tr><td>__ 1 7</td><td>MTTR (During tough drive)</td></tr> </tbody> </table> | Setting digit | Explanation | Initial value | __ x x | Device selection Refer to table 5.8 for settings. | 05h | _ x _ _ | For manufacturer setting | 0h | x _ _ _ | | 0h | Setting value | Output device | __ 0 0 | Always off | __ 0 2 | RD (Ready) | __ 0 3 | ALM (Malfunction) | __ 0 4 | INP (In-position) | __ 0 5 | MBR (Electromagnetic brake interlock) | __ 0 7 | TLC (Limiting torque) | __ 0 8 | WNG (Warning) | __ 0 9 | BWNG (Battery warning) | __ 0 A | SA (Speed reached) | __ 0 C | ZSP (Zero speed detection) | __ 0 F | CDPS (Variable gain selection) | __ 1 0 | CLDS (During fully closed loop control) | __ 1 1 | ABSV (Absolute position undetermined) | __ 1 7 | MTTR (During tough drive) | Refer to Name and function column. | | Each |
| Setting digit | Explanation | Initial value | | | | | | | | | | | | | | | | | | | | | | | | | | | | | | | | | | | | | | | | | | | | | |
| __ x x | Device selection Refer to table 5.8 for settings. | 05h | | | | | | | | | | | | | | | | | | | | | | | | | | | | | | | | | | | | | | | | | | | | | |
| _ x _ _ | For manufacturer setting | 0h | | | | | | | | | | | | | | | | | | | | | | | | | | | | | | | | | | | | | | | | | | | | | |
| x _ _ _ | | 0h | | | | | | | | | | | | | | | | | | | | | | | | | | | | | | | | | | | | | | | | | | | | | |
| Setting value | Output device | | | | | | | | | | | | | | | | | | | | | | | | | | | | | | | | | | | | | | | | | | | | | | |
| __ 0 0 | Always off | | | | | | | | | | | | | | | | | | | | | | | | | | | | | | | | | | | | | | | | | | | | | | |
| __ 0 2 | RD (Ready) | | | | | | | | | | | | | | | | | | | | | | | | | | | | | | | | | | | | | | | | | | | | | | |
| __ 0 3 | ALM (Malfunction) | | | | | | | | | | | | | | | | | | | | | | | | | | | | | | | | | | | | | | | | | | | | | | |
| __ 0 4 | INP (In-position) | | | | | | | | | | | | | | | | | | | | | | | | | | | | | | | | | | | | | | | | | | | | | | |
| __ 0 5 | MBR (Electromagnetic brake interlock) | | | | | | | | | | | | | | | | | | | | | | | | | | | | | | | | | | | | | | | | | | | | | | |
| __ 0 7 | TLC (Limiting torque) | | | | | | | | | | | | | | | | | | | | | | | | | | | | | | | | | | | | | | | | | | | | | | |
| __ 0 8 | WNG (Warning) | | | | | | | | | | | | | | | | | | | | | | | | | | | | | | | | | | | | | | | | | | | | | | |
| __ 0 9 | BWNG (Battery warning) | | | | | | | | | | | | | | | | | | | | | | | | | | | | | | | | | | | | | | | | | | | | | | |
| __ 0 A | SA (Speed reached) | | | | | | | | | | | | | | | | | | | | | | | | | | | | | | | | | | | | | | | | | | | | | | |
| __ 0 C | ZSP (Zero speed detection) | | | | | | | | | | | | | | | | | | | | | | | | | | | | | | | | | | | | | | | | | | | | | | |
| __ 0 F | CDPS (Variable gain selection) | | | | | | | | | | | | | | | | | | | | | | | | | | | | | | | | | | | | | | | | | | | | | | |
| __ 1 0 | CLDS (During fully closed loop control) | | | | | | | | | | | | | | | | | | | | | | | | | | | | | | | | | | | | | | | | | | | | | | |
| __ 1 1 | ABSV (Absolute position undetermined) | | | | | | | | | | | | | | | | | | | | | | | | | | | | | | | | | | | | | | | | | | | | | | |
| __ 1 7 | MTTR (During tough drive) | | | | | | | | | | | | | | | | | | | | | | | | | | | | | | | | | | | | | | | | | | | | | | |
| PD08 | *DO2 | <p>Output device selection 2</p> <p>You can assign any output device to the CN3-24 pin for each axis. C INP (AND in-position) is assigned to all the axes in the initial setting.</p> <p>The devices that can be assigned and the setting method are the same as in [Pr. PD07].</p> <table border="1"> <thead> <tr> <th>Setting digit</th> <th>Explanation</th> <th>Initial value</th> </tr> </thead> <tbody> <tr> <td>__ x x</td> <td>Device selection Refer to table 5.8 in [Pr. PD07] for settings.</td> <td>04h</td> </tr> <tr> <td>_ x _ _</td> <td>All-axis output condition selection 0: AND output When all axes of A, B, and C meet a condition, the device will be enabled (on or off). 1: OR output When each axis of A, B, or C meet a condition, the device will be enabled (on or off). The digit will be enabled when "All axes (0 __ _)" is selected.</td> <td>0h</td> </tr> <tr> <td>x _ _ _</td> <td>Output axis selection 0: All axes 1: A-axis 2: B-axis 3: C-axis</td> <td>0h</td> </tr> </tbody> </table> | Setting digit | Explanation | Initial value | __ x x | Device selection Refer to table 5.8 in [Pr. PD07] for settings. | 04h | _ x _ _ | All-axis output condition selection 0: AND output When all axes of A, B, and C meet a condition, the device will be enabled (on or off). 1: OR output When each axis of A, B, or C meet a condition, the device will be enabled (on or off). The digit will be enabled when "All axes (0 __ _)" is selected. | 0h | x _ _ _ | Output axis selection 0: All axes 1: A-axis 2: B-axis 3: C-axis | 0h | Refer to Name and function column. | | Common | | | | | | | | | | | | | | | | | | | | | | | | | | | | | | |
| Setting digit | Explanation | Initial value | | | | | | | | | | | | | | | | | | | | | | | | | | | | | | | | | | | | | | | | | | | | | |
| __ x x | Device selection Refer to table 5.8 in [Pr. PD07] for settings. | 04h | | | | | | | | | | | | | | | | | | | | | | | | | | | | | | | | | | | | | | | | | | | | | |
| _ x _ _ | All-axis output condition selection 0: AND output When all axes of A, B, and C meet a condition, the device will be enabled (on or off). 1: OR output When each axis of A, B, or C meet a condition, the device will be enabled (on or off). The digit will be enabled when "All axes (0 __ _)" is selected. | 0h | | | | | | | | | | | | | | | | | | | | | | | | | | | | | | | | | | | | | | | | | | | | | |
| x _ _ _ | Output axis selection 0: All axes 1: A-axis 2: B-axis 3: C-axis | 0h | | | | | | | | | | | | | | | | | | | | | | | | | | | | | | | | | | | | | | | | | | | | | |

5. PARAMETERS

| No. | Symbol | Name and function | Initial value [unit] | Setting range | Each/ Common | | | | | | | | | | | | | |
|---------------|------------------------------------------------------------------------------------------------------------------------------------------------------------------------------------------------------------------------------------------------------------------------------------------------------------------------------|----------------------------------------------------------------------------------------------------------------------------------------------------------------------------------------------------------------------------------------------------------------------------------------------------------------------------------------------------------------------------------------------------------------------------------------------------------------------------------------------------------------------------------------------------------------------------------------------------------------------------------------------------------------------------------------------------------------------------------------------------------------------------------------------------------------------------------------------------------------------------------------------------------------------------------------------------------------------------------------------------------------------------------------------------------------------|----------------------|---------------|---------------|--------|-------------------------------------------------------------------------------------------------------------------------------------------------------------------------------------------------------------------------------------------------------------------------------------------------|-----|--------|------------------------------------------------------------------------------------------------------------------------------------------------------------------------------------------------------------------------------------------------------------------------------------------------------------------------------|--------|--------|-----------------------------------------------------------------------------|-------------------------------------------------------------------------------------------------------------------------------------------------------------------------------------------------------------------------------------------------------------------------|------------------------------------|------------------------------------|--------|--------|
| PD09 | *DO3 | <p>Output device selection 3</p> <p>You can assign any output device to the CN3-11 pin for each axis. CALM (AND malfunction) is assigned to all the axes in the initial setting.</p> <p>The devices that can be assigned and the setting method are the same as in [Pr. PD07].</p> <table border="1"> <thead> <tr> <th>Setting digit</th> <th>Explanation</th> <th>Initial value</th> </tr> </thead> <tbody> <tr> <td>__ x x</td> <td>Device selection Refer to table 5.8 in [Pr. PD07] for settings.</td> <td>03h</td> </tr> <tr> <td>_ x __</td> <td>All-axis output condition selection 0: AND output When all axes of A, B, and C meet a condition, the device will be enabled (on or off). 1: OR output When each axis of A, B, or C meet a condition, the device will be enabled (on or off). The digit will be enabled when "All axes (0 __ __)" is selected.</td> <td>0h</td> </tr> <tr> <td>x ___</td> <td>Output axis selection 0: All axes 1: A-axis 2: B-axis 3: C-axis</td> <td>0h</td> </tr> </tbody> </table> | Setting digit | Explanation | Initial value | __ x x | Device selection Refer to table 5.8 in [Pr. PD07] for settings. | 03h | _ x __ | All-axis output condition selection 0: AND output When all axes of A, B, and C meet a condition, the device will be enabled (on or off). 1: OR output When each axis of A, B, or C meet a condition, the device will be enabled (on or off). The digit will be enabled when "All axes (0 __ __)" is selected. | 0h | x ___ | Output axis selection 0: All axes 1: A-axis 2: B-axis 3: C-axis | 0h | Refer to Name and function column. | | Common | |
| Setting digit | Explanation | Initial value | | | | | | | | | | | | | | | | |
| __ x x | Device selection Refer to table 5.8 in [Pr. PD07] for settings. | 03h | | | | | | | | | | | | | | | | |
| _ x __ | All-axis output condition selection 0: AND output When all axes of A, B, and C meet a condition, the device will be enabled (on or off). 1: OR output When each axis of A, B, or C meet a condition, the device will be enabled (on or off). The digit will be enabled when "All axes (0 __ __)" is selected. | 0h | | | | | | | | | | | | | | | | |
| x ___ | Output axis selection 0: All axes 1: A-axis 2: B-axis 3: C-axis | 0h | | | | | | | | | | | | | | | | |
| PD11 | *DIF | <p>Input filter setting</p> <p>Select the input filter.</p> <table border="1"> <thead> <tr> <th>Setting digit</th> <th>Explanation</th> <th>Initial value</th> </tr> </thead> <tbody> <tr> <td>___ x</td> <td>Input signal filter selection Refer to the servo system controller instruction manual for the setting. If external input signal causes chattering due to noise, etc., input filter is used to suppress it. 0: None 1: 0.888 [ms] 2: 1.777 [ms] 3: 2.666 [ms] 4: 3.555 [ms]</td> <td>4h</td> </tr> <tr> <td>__ x _</td> <td rowspan="3">For manufacturer setting</td> <td>0h</td> </tr> <tr> <td>_ x __</td> <td>0h</td> </tr> <tr> <td>x ___</td> <td>0h</td> </tr> </tbody> </table> | Setting digit | Explanation | Initial value | ___ x | Input signal filter selection Refer to the servo system controller instruction manual for the setting. If external input signal causes chattering due to noise, etc., input filter is used to suppress it. 0: None 1: 0.888 [ms] 2: 1.777 [ms] 3: 2.666 [ms] 4: 3.555 [ms] | 4h | __ x _ | For manufacturer setting | 0h | _ x __ | 0h | x ___ | 0h | Refer to Name and function column. | | Common |
| Setting digit | Explanation | Initial value | | | | | | | | | | | | | | | | |
| ___ x | Input signal filter selection Refer to the servo system controller instruction manual for the setting. If external input signal causes chattering due to noise, etc., input filter is used to suppress it. 0: None 1: 0.888 [ms] 2: 1.777 [ms] 3: 2.666 [ms] 4: 3.555 [ms] | 4h | | | | | | | | | | | | | | | | |
| __ x _ | For manufacturer setting | 0h | | | | | | | | | | | | | | | | |
| _ x __ | | 0h | | | | | | | | | | | | | | | | |
| x ___ | | 0h | | | | | | | | | | | | | | | | |
| PD12 | *DOP1 | <p>Function selection D-1</p> <table border="1"> <thead> <tr> <th>Setting digit</th> <th>Explanation</th> <th>Initial value</th> </tr> </thead> <tbody> <tr> <td>___ x</td> <td rowspan="3">For manufacturer setting</td> <td>0h</td> </tr> <tr> <td>__ x _</td> <td>0h</td> </tr> <tr> <td>_ x __</td> <td>0h</td> </tr> <tr> <td>x ___</td> <td>Servo motor or linear servo motor thermistor enabled/ disabled selection (Supported by servo amplifiers with software version A5 or later.) 0: Enabled 1: Disabled For servo motors or linear servo motor without thermistor, the setting will be disabled.</td> <td>0h</td> </tr> </tbody> </table> | Setting digit | Explanation | Initial value | ___ x | For manufacturer setting | 0h | __ x _ | 0h | _ x __ | 0h | x ___ | Servo motor or linear servo motor thermistor enabled/ disabled selection (Supported by servo amplifiers with software version A5 or later.) 0: Enabled 1: Disabled For servo motors or linear servo motor without thermistor, the setting will be disabled. | 0h | Refer to Name and function column. | | Each |
| Setting digit | Explanation | Initial value | | | | | | | | | | | | | | | | |
| ___ x | For manufacturer setting | 0h | | | | | | | | | | | | | | | | |
| __ x _ | | 0h | | | | | | | | | | | | | | | | |
| _ x __ | | 0h | | | | | | | | | | | | | | | | |
| x ___ | Servo motor or linear servo motor thermistor enabled/ disabled selection (Supported by servo amplifiers with software version A5 or later.) 0: Enabled 1: Disabled For servo motors or linear servo motor without thermistor, the setting will be disabled. | 0h | | | | | | | | | | | | | | | | |

5. PARAMETERS

| No. | Symbol | Name and function | Initial value [unit] | Setting range | Each/ Common | | | | | | | | | | | | | | | | | | | | | | | | | | | | | | | | | | | | | | | | | | | | |
|---------------|--------------------------------------------------------------------------------------------------------------------------------------------------------------------------------------------------------------------------------------------------------------------------------------------------------------------------------|-----------------------------------------------------------------------------------------------------------------------------------------------------------------------------------------------------------------------------------------------------------------------------------------------------------------------------------------------------------------------------------------------------------------------------------------------------------------------------------------------------------------------------------------------------------------------------------------------------------------------------------------------------------------------------------------------------------------------------------------------------------------------------------------------------------------------------------------------------------------------------------------------------------------------------------------------------------------------------------------------------------------------------------------------------------------------------------------------------------------------------------------------------------------------------------------------------------------------------------------------------------------------------------------|------------------------|---------------|-----------------------------------------------------------|------|--------------------------------------------------------------------|----|------|-------------------------------------------------------------------------------------------------------------------------------------|----|--|------------------------|--|--|--------------------------------------------------------------------------------------------------------------------------------------------------------------------------------------------------------------------------------------------------------------------------------------------------------------------------------|---------------|------------------------|---|-----------------------------------------------------------|---|--------------------------------------------------------------------|--|--|--|-------------------------|--|--|--|--|--|----------------------------------------------------------------------------------------------------------|--|--|--|--|--|--------|----|--|--|--|--|------|----|--|--|------------------------------------|------|
| PD14 | *DOP3 | Function selection D-3 | | | | | | | | | | | | | | | | | | | | | | | | | | | | | | | | | | | | | | | | | | | | | | | |
| | | <table border="1"> <thead> <tr> <th>Setting digit</th> <th>Explanation</th> <th>Initial value</th> </tr> </thead> <tbody> <tr> <td>___x</td> <td>For manufacturer setting</td> <td>0h</td> </tr> <tr> <td>__x_</td> <td>Selection of output device at warning occurrence Select WNG (Warning) and ALM (Malfunction) output status at warning occurrence.</td> <td>0h</td> </tr> <tr> <td></td> <td>Servo amplifier output</td> <td></td> </tr> <tr> <td></td> <td> <table border="1"> <thead> <tr> <th>Setting value</th> <th>(Note 1) Device status</th> </tr> </thead> <tbody> <tr> <td>0</td> <td> <p>WNG 1 0 ALM 1 0 Warning occurrence</p> </td> </tr> <tr> <td>1</td> <td> <p>WNG 1 0 ALM 1 0 Warning occurrence (Note 2)</p> </td> </tr> </tbody> </table> </td> <td></td> </tr> <tr> <td></td> <td></td> <td>Note 1. 0: Off 1: On</td> <td></td> <td></td> <td></td> </tr> <tr> <td></td> <td></td> <td>2. Although ALM is turned off upon occurrence of the warning, the forced stop deceleration is performed.</td> <td></td> <td></td> <td></td> </tr> <tr> <td></td> <td></td> <td>___x__</td> <td>0h</td> <td></td> <td></td> </tr> <tr> <td></td> <td></td> <td>x___</td> <td>0h</td> <td></td> <td></td> </tr> </tbody> </table> | Setting digit | Explanation | Initial value | ___x | For manufacturer setting | 0h | __x_ | Selection of output device at warning occurrence Select WNG (Warning) and ALM (Malfunction) output status at warning occurrence. | 0h | | Servo amplifier output | | | <table border="1"> <thead> <tr> <th>Setting value</th> <th>(Note 1) Device status</th> </tr> </thead> <tbody> <tr> <td>0</td> <td> <p>WNG 1 0 ALM 1 0 Warning occurrence</p> </td> </tr> <tr> <td>1</td> <td> <p>WNG 1 0 ALM 1 0 Warning occurrence (Note 2)</p> </td> </tr> </tbody> </table> | Setting value | (Note 1) Device status | 0 | <p>WNG 1 0 ALM 1 0 Warning occurrence</p> | 1 | <p>WNG 1 0 ALM 1 0 Warning occurrence (Note 2)</p> | | | | Note 1. 0: Off 1: On | | | | | | 2. Although ALM is turned off upon occurrence of the warning, the forced stop deceleration is performed. | | | | | | ___x__ | 0h | | | | | x___ | 0h | | | Refer to Name and function column. | Each |
| Setting digit | Explanation | Initial value | | | | | | | | | | | | | | | | | | | | | | | | | | | | | | | | | | | | | | | | | | | | | | | |
| ___x | For manufacturer setting | 0h | | | | | | | | | | | | | | | | | | | | | | | | | | | | | | | | | | | | | | | | | | | | | | | |
| __x_ | Selection of output device at warning occurrence Select WNG (Warning) and ALM (Malfunction) output status at warning occurrence. | 0h | | | | | | | | | | | | | | | | | | | | | | | | | | | | | | | | | | | | | | | | | | | | | | | |
| | Servo amplifier output | | | | | | | | | | | | | | | | | | | | | | | | | | | | | | | | | | | | | | | | | | | | | | | | |
| | <table border="1"> <thead> <tr> <th>Setting value</th> <th>(Note 1) Device status</th> </tr> </thead> <tbody> <tr> <td>0</td> <td> <p>WNG 1 0 ALM 1 0 Warning occurrence</p> </td> </tr> <tr> <td>1</td> <td> <p>WNG 1 0 ALM 1 0 Warning occurrence (Note 2)</p> </td> </tr> </tbody> </table> | Setting value | (Note 1) Device status | 0 | <p>WNG 1 0 ALM 1 0 Warning occurrence</p> | 1 | <p>WNG 1 0 ALM 1 0 Warning occurrence (Note 2)</p> | | | | | | | | | | | | | | | | | | | | | | | | | | | | | | | | | | | | | | | | | | |
| Setting value | (Note 1) Device status | | | | | | | | | | | | | | | | | | | | | | | | | | | | | | | | | | | | | | | | | | | | | | | | |
| 0 | <p>WNG 1 0 ALM 1 0 Warning occurrence</p> | | | | | | | | | | | | | | | | | | | | | | | | | | | | | | | | | | | | | | | | | | | | | | | | |
| 1 | <p>WNG 1 0 ALM 1 0 Warning occurrence (Note 2)</p> | | | | | | | | | | | | | | | | | | | | | | | | | | | | | | | | | | | | | | | | | | | | | | | | |
| | | Note 1. 0: Off 1: On | | | | | | | | | | | | | | | | | | | | | | | | | | | | | | | | | | | | | | | | | | | | | | | |
| | | 2. Although ALM is turned off upon occurrence of the warning, the forced stop deceleration is performed. | | | | | | | | | | | | | | | | | | | | | | | | | | | | | | | | | | | | | | | | | | | | | | | |
| | | ___x__ | 0h | | | | | | | | | | | | | | | | | | | | | | | | | | | | | | | | | | | | | | | | | | | | | | |
| | | x___ | 0h | | | | | | | | | | | | | | | | | | | | | | | | | | | | | | | | | | | | | | | | | | | | | | |

5. PARAMETERS

5.2.5 Extension setting 2 parameters ([Pr. PE_ _])

| No. | Symbol | Name and function | Initial value [unit] | Setting range | Each/ Common | | | | | | | | | | | | | | | | | | | | | |
|--------------------------------------------------|----------------------------------------------------------------------------------------------------------------------------------------------------------------------------------------------------------------------------------------------------------------------------------------------------------------------------------------------------------------------------------------------------------------------------------------------------------------------------------------------------------------------------------------------------------------------------------------------------------------------------------------------------------------------------------------------------|---------------------------------------------------------------------------------------------------------------------------------------------------------------------------------------------------------------------------------------------------------------------------------------------------------------------------------------------------------------------------------------------------------------------------------------------------------------------------------------------------------------------------------------------------------------------------------------------------------------------------------------------------------------------------------------------------------------------------------------------------------------------------------------------------------------------------------------------------------------------------------------------------------------------------------------------------------------------------------------------------------------------------------------------------------------------------------------------------------------------------------------------------------------------------------------------|----------------------|---------------|--------------------------|------|----------------------------------------------------------------------------------------------------------------------------------------------------------------------------------------------------------------------------------------------------------------------------------------------------------------------------------------------------------------------------------------------------------------------------------------------------------------------------------------------------------------------------------------------------------------------------------------------------------------------------------------------------------------------------------------------------|--------------------------------------------------|----------------|------------------------------------------------------------------------------------------------------------------------------------------------------------------|--------------------------|------|---------------------------|----|------|--------------------------------------------------------------------------------------------------------------------------------------|----|------------------------------------|--|------|------|--|----|------------------------------------|--|------|
| PE01 | **FCT1 | <p>Fully closed loop function selection 1 This parameter is not available with MR-J4W2-0303B6 servo amplifiers.</p> <table border="1"> <thead> <tr> <th>Setting digit</th> <th>Explanation</th> <th>Initial value</th> </tr> </thead> <tbody> <tr> <td>___x</td> <td> <p>Fully closed loop function selection 0: Always enabled 1: Switching with the control command of controller (switching semi./full.)</p> <table border="1"> <thead> <tr> <th>Switching with the control command of controller</th> <th>Control system</th> </tr> </thead> <tbody> <tr> <td>Off</td> <td>Semi closed loop control</td> </tr> <tr> <td>On</td> <td>Fully closed loop control</td> </tr> </tbody> </table> <p>To enable the digit, select "Fully closed loop control mode (_ 1 _)" of "operation mode selection" in [Pr. PA01]. When "Absolute position detection system" is "Enabled (_ _ 1)" in [Pr. PA03], setting "1" will trigger [AL. 37 Parameter error].</p> </td> <td>0h</td> </tr> <tr> <td>__x_</td> <td>For manufacturer setting</td> <td>0h</td> </tr> <tr> <td>_x__</td> <td></td> <td>0h</td> </tr> <tr> <td>x___</td> <td></td> <td>0h</td> </tr> </tbody> </table> | Setting digit | Explanation | Initial value | ___x | <p>Fully closed loop function selection 0: Always enabled 1: Switching with the control command of controller (switching semi./full.)</p> <table border="1"> <thead> <tr> <th>Switching with the control command of controller</th> <th>Control system</th> </tr> </thead> <tbody> <tr> <td>Off</td> <td>Semi closed loop control</td> </tr> <tr> <td>On</td> <td>Fully closed loop control</td> </tr> </tbody> </table> <p>To enable the digit, select "Fully closed loop control mode (_ 1 _)" of "operation mode selection" in [Pr. PA01]. When "Absolute position detection system" is "Enabled (_ _ 1)" in [Pr. PA03], setting "1" will trigger [AL. 37 Parameter error].</p> | Switching with the control command of controller | Control system | Off | Semi closed loop control | On | Fully closed loop control | 0h | __x_ | For manufacturer setting | 0h | _x__ | | 0h | x___ | | 0h | Refer to Name and function column. | | Each |
| Setting digit | Explanation | Initial value | | | | | | | | | | | | | | | | | | | | | | | | |
| ___x | <p>Fully closed loop function selection 0: Always enabled 1: Switching with the control command of controller (switching semi./full.)</p> <table border="1"> <thead> <tr> <th>Switching with the control command of controller</th> <th>Control system</th> </tr> </thead> <tbody> <tr> <td>Off</td> <td>Semi closed loop control</td> </tr> <tr> <td>On</td> <td>Fully closed loop control</td> </tr> </tbody> </table> <p>To enable the digit, select "Fully closed loop control mode (_ 1 _)" of "operation mode selection" in [Pr. PA01]. When "Absolute position detection system" is "Enabled (_ _ 1)" in [Pr. PA03], setting "1" will trigger [AL. 37 Parameter error].</p> | Switching with the control command of controller | Control system | Off | Semi closed loop control | On | Fully closed loop control | 0h | | | | | | | | | | | | | | | | | | |
| Switching with the control command of controller | Control system | | | | | | | | | | | | | | | | | | | | | | | | | |
| Off | Semi closed loop control | | | | | | | | | | | | | | | | | | | | | | | | | |
| On | Fully closed loop control | | | | | | | | | | | | | | | | | | | | | | | | | |
| __x_ | For manufacturer setting | 0h | | | | | | | | | | | | | | | | | | | | | | | | |
| _x__ | | 0h | | | | | | | | | | | | | | | | | | | | | | | | |
| x___ | | 0h | | | | | | | | | | | | | | | | | | | | | | | | |
| PE03 | *FCT2 | <p>Fully closed loop function selection 2 This parameter is not available with MR-J4W2-0303B6 servo amplifiers.</p> <table border="1"> <thead> <tr> <th>Setting digit</th> <th>Explanation</th> <th>Initial value</th> </tr> </thead> <tbody> <tr> <td>___x</td> <td> <p>Fully closed loop control error detection function selection 0: Disabled 1: Speed deviation error detection 2: Position deviation error detection 3: Speed deviation error/position deviation error detection</p> </td> <td>3h</td> </tr> <tr> <td>__x_</td> <td> <p>Position deviation error detection system selection 0: Continuous detection system 1: Detection system at stop (detected with command set to "0")</p> </td> <td>0h</td> </tr> <tr> <td>_x__</td> <td>For manufacturer setting</td> <td>0h</td> </tr> <tr> <td>x___</td> <td> <p>Fully closed loop control error reset selection 0: Reset disabled (reset by powering off/on enabled) 1: Reset enabled</p> </td> <td>0h</td> </tr> </tbody> </table> | Setting digit | Explanation | Initial value | ___x | <p>Fully closed loop control error detection function selection 0: Disabled 1: Speed deviation error detection 2: Position deviation error detection 3: Speed deviation error/position deviation error detection</p> | 3h | __x_ | <p>Position deviation error detection system selection 0: Continuous detection system 1: Detection system at stop (detected with command set to "0")</p> | 0h | _x__ | For manufacturer setting | 0h | x___ | <p>Fully closed loop control error reset selection 0: Reset disabled (reset by powering off/on enabled) 1: Reset enabled</p> | 0h | Refer to Name and function column. | | Each | | | | | | |
| Setting digit | Explanation | Initial value | | | | | | | | | | | | | | | | | | | | | | | | |
| ___x | <p>Fully closed loop control error detection function selection 0: Disabled 1: Speed deviation error detection 2: Position deviation error detection 3: Speed deviation error/position deviation error detection</p> | 3h | | | | | | | | | | | | | | | | | | | | | | | | |
| __x_ | <p>Position deviation error detection system selection 0: Continuous detection system 1: Detection system at stop (detected with command set to "0")</p> | 0h | | | | | | | | | | | | | | | | | | | | | | | | |
| _x__ | For manufacturer setting | 0h | | | | | | | | | | | | | | | | | | | | | | | | |
| x___ | <p>Fully closed loop control error reset selection 0: Reset disabled (reset by powering off/on enabled) 1: Reset enabled</p> | 0h | | | | | | | | | | | | | | | | | | | | | | | | |
| PE04 | **FBN | <p>Fully closed loop control - Feedback pulse electronic gear 1 - Numerator Set a numerator of electronic gear for the servo motor encoder pulse at the fully closed loop control. Set the electronic gear so that the number of servo motor encoder pulses for one servo motor revolution is converted to the resolution of the load-side encoder. This parameter is not available with MR-J4W2-0303B6 servo amplifiers.</p> | 1 | 1 to 65535 | Each | | | | | | | | | | | | | | | | | | | | | |
| PE05 | **FBD | <p>Fully closed loop control - Feedback pulse electronic gear 1 - Denominator Set a denominator of electronic gear for the servo motor encoder pulse at the fully closed loop control. Set the electronic gear so that the number of servo motor encoder pulses for one servo motor revolution is converted to the resolution of the load-side encoder. This parameter is not available with MR-J4W2-0303B6 servo amplifiers.</p> | 1 | 1 to 65535 | Each | | | | | | | | | | | | | | | | | | | | | |
| PE06 | BC1 | <p>Fully closed loop control - Speed deviation error detection level Set [AL. 42.9 Fully closed loop control error by speed deviation] of. When the speed deviation between the servo motor encoder and load-side encoder becomes larger than the setting value, the alarm will occur. This parameter is not available with MR-J4W2-0303B6 servo amplifiers.</p> | 400 [r/min] | 1 to 50000 | Each | | | | | | | | | | | | | | | | | | | | | |

5. PARAMETERS

| No. | Symbol | Name and function | Initial value [unit] | Setting range | Each/ Common | | | | | | | | | | | | | | | |
|---------------|-----------------------------------------------------------------------------------------------------------------------------------------------------------------------------------------------------------------------------|--------------------------------------------------------------------------------------------------------------------------------------------------------------------------------------------------------------------------------------------------------------------------------------------------------------------------------------------------------------------------------------------------------------------------------------------------------------------------------------------------------------------------------------------------------------------------------------------------------------------------------------------------------------------------------------------------------------------------------------------------------------------------------------------------------------------------------------------------------------------------------------------|------------------------------------|---------------|---------------|------|---------------------------------------------------------------------------------------------------------------------------------------------------------------------------------|----|------|------------------------------------------------------------------------------------------------------------------------------|----|------|--------------------------------------------------------------------------------------------------------------------------------------------------------------|------|------|-----------------------------------------------------------------------------------------------------------------------------------------------------------------------------------------------------------------------------|----|--|--|--|
| PE07 | BC2 | Fully closed loop control - Position deviation error detection level Set [AL. 42.8 Fully closed loop control error by position deviation] of the fully closed loop control error detection. When the position deviation between the servo motor encoder and load-side encoder becomes larger than the setting value, the alarm will occur. This parameter is not available with MR-J4W2-0303B6 servo amplifiers. | 100 [kpulse] | 1 to 20000 | Each | | | | | | | | | | | | | | | |
| PE08 | DUF | Fully closed loop dual feedback filter Set a dual feedback filter band. Refer to section 16.3.1 (6) for details. This parameter is not available with MR-J4W2-0303B6 servo amplifiers. | [rad/s] | 0 to 4500 | Each | | | | | | | | | | | | | | | |
| PE10 | FCT3 | Fully closed loop function selection 3 This parameter is not available with MR-J4W2-0303B6 servo amplifiers. | Refer to Name and function column. | | Each | | | | | | | | | | | | | | | |
| | | <table border="1"> <thead> <tr> <th>Setting digit</th> <th>Explanation</th> <th>Initial value</th> </tr> </thead> <tbody> <tr> <td>___x</td> <td>For manufacturer setting</td> <td>0h</td> </tr> <tr> <td>__x_</td> <td>Fully closed loop control - Position deviation error detection level - Unit selection 0: 1 kpulse unit 1: 1 pulse unit</td> <td>0h</td> </tr> <tr> <td>_x__</td> <td>Droop pulse monitor selection for controller display 0: Servo motor encoder 1: Load-side encoder 2: Deviation between the servo motor and load side</td> <td>0h</td> </tr> <tr> <td>x___</td> <td>Cumulative feedback pulses monitor selection for controller display 0: Servo motor encoder 1: Load-side encoder The setting of this digit is used for the fully closed loop system and scale measurement function.</td> <td>0h</td> </tr> </tbody> </table> | Setting digit | Explanation | Initial value | ___x | For manufacturer setting | 0h | __x_ | Fully closed loop control - Position deviation error detection level - Unit selection 0: 1 kpulse unit 1: 1 pulse unit | 0h | _x__ | Droop pulse monitor selection for controller display 0: Servo motor encoder 1: Load-side encoder 2: Deviation between the servo motor and load side | 0h | x___ | Cumulative feedback pulses monitor selection for controller display 0: Servo motor encoder 1: Load-side encoder The setting of this digit is used for the fully closed loop system and scale measurement function. | 0h | | | |
| Setting digit | Explanation | Initial value | | | | | | | | | | | | | | | | | | |
| ___x | For manufacturer setting | 0h | | | | | | | | | | | | | | | | | | |
| __x_ | Fully closed loop control - Position deviation error detection level - Unit selection 0: 1 kpulse unit 1: 1 pulse unit | 0h | | | | | | | | | | | | | | | | | | |
| _x__ | Droop pulse monitor selection for controller display 0: Servo motor encoder 1: Load-side encoder 2: Deviation between the servo motor and load side | 0h | | | | | | | | | | | | | | | | | | |
| x___ | Cumulative feedback pulses monitor selection for controller display 0: Servo motor encoder 1: Load-side encoder The setting of this digit is used for the fully closed loop system and scale measurement function. | 0h | | | | | | | | | | | | | | | | | | |
| PE34 | **FBN2 | Fully closed loop control - Feedback pulse electronic gear 2 - Numerator Set a numerator of electronic gear for the servo motor encoder pulse at the fully closed loop control. Set the electronic gear so that the number of servo motor encoder pulses for one servo motor revolution is converted to the resolution of the load-side encoder. Refer to section 16.3.1 (4) for details. This parameter is not available with MR-J4W2-0303B6 servo amplifiers. | 1 | 1 to 65535 | Each | | | | | | | | | | | | | | | |
| PE35 | **FBD2 | Fully closed loop control - Feedback pulse electronic gear 2 - Denominator Set a denominator of electronic gear for the servo motor encoder pulse at the fully closed loop control. Set the electronic gear so that the number of servo motor encoder pulses for one servo motor revolution is converted to the resolution of the load-side encoder. Refer to section 16.3.1 (4) for details. This parameter is not available with MR-J4W2-0303B6 servo amplifiers. | 1 | 1 to 65535 | Each | | | | | | | | | | | | | | | |
| PE41 | EOP3 | Function selection E-3 | Refer to Name and function column. | | Each | | | | | | | | | | | | | | | |
| | | <table border="1"> <thead> <tr> <th>Setting digit</th> <th>Explanation</th> <th>Initial value</th> </tr> </thead> <tbody> <tr> <td>___x</td> <td>Robust filter selection 0: Disabled 1: Enabled When you select "Enabled" of this digit, the machine resonance suppression filter 5 set in [Pr. PB51] is not available.</td> <td>0h</td> </tr> <tr> <td>__x_</td> <td rowspan="3">For manufacturer setting</td> <td>0h</td> </tr> <tr> <td>_x__</td> <td>0h</td> </tr> <tr> <td>x___</td> <td>0h</td> </tr> </tbody> </table> | Setting digit | Explanation | Initial value | ___x | Robust filter selection 0: Disabled 1: Enabled When you select "Enabled" of this digit, the machine resonance suppression filter 5 set in [Pr. PB51] is not available. | 0h | __x_ | For manufacturer setting | 0h | _x__ | 0h | x___ | 0h | | | | | |
| Setting digit | Explanation | Initial value | | | | | | | | | | | | | | | | | | |
| ___x | Robust filter selection 0: Disabled 1: Enabled When you select "Enabled" of this digit, the machine resonance suppression filter 5 set in [Pr. PB51] is not available. | 0h | | | | | | | | | | | | | | | | | | |
| __x_ | For manufacturer setting | 0h | | | | | | | | | | | | | | | | | | |
| _x__ | | 0h | | | | | | | | | | | | | | | | | | |
| x___ | | 0h | | | | | | | | | | | | | | | | | | |

5. PARAMETERS

| No. | Symbol | Name and function | Initial value [unit] | Setting range | Each/ Common |
|------|--------|------------------------------------------------------------------------------------------------------------------------------------------------------------------------------------------------------------------------------------------------------------------------------------------------------------------------------------------------------------------------------------------------------------------------------------------------------------------------------------------------------------------------------------------------------------------------------------------------------------------------------------|----------------------|-----------------------|--------------|
| PE47 | TOF | <p>Torque offset</p> <p>Set this when canceling unbalanced torque of vertical axis. Set this assuming the rated torque of the servo motor as 100%. The torque offset does not need to be set for a machine not generating unbalanced torque. The torque offset cannot be used for linear servo motors and direct drive motors. Set 0.00%.</p> <p>The torque offset set with this parameter will be enabled in the position control mode, speed control mode, and torque control mode. Input commands assuming torque offset for the torque control mode.</p> <p>This parameter is supported with software version B4 or later.</p> | 0 [0.01%] | -10000 to 10000 | Each |

5.2.6 Extension setting 3 parameters ([Pr. PF__])

| No. | Symbol | Name and function | Initial value [unit] | Setting range | Each/ Common | | | | | | | | | | | | | | | | | | | | | | |
|---------------|-------------------------------------------------------------------------------------------------------------------------------------------------------------------------------------------------------------------------------------------------------------------------------------------------------------------------------------------------------------------------------------------------------------------------------------------------------------------------------------------------------------------------------------------------------------------------------------------------------------------------------------------------------------|----------------------------------------------------------------------------------------------------------------------------------------------------------------------------------------------------------------------------------------------------------------------------------------------------------------------------------------------------------------------------------------------------------------------------------------------------------------------------------------------------------------------------------------------------------------------------------------------------------------------------------------------------------------------------------------------------------------------------------------------------------------------------------------------------------------------------------------------------------------------------------------------------------------------------------------------------------------------------------------------------------------------------------------------------------------------------------------------------------------------------------------------------------------|----------------------|---------------|----------------------------------|-------|-------------------------------------------------------------------------------------------------------------------------------------------------------------------------------------------------------------------------------------------------------------------------------------------------------------------------------------------------------------------------------------------------------------------------------------------------------------------------------------------------------------------------------------------------------------------------------------------------------------------------------------------------------------|--------|-----------------|--------------------------|----------------------------------|-------|----------------------------------|-------|-----------------|------------------------------------|-------------------------------|----|------|--------------------------|----|------|----|------|----|------------------------------------|------|
| PF02 | *FOP2 | <p>Function selection F-2</p> <p>Set targets of [AL. EB The other axis error warning].</p> <table border="1" style="width: 100%; border-collapse: collapse;"> <thead> <tr> <th style="width: 15%;">Setting digit</th> <th style="width: 65%;">Explanation</th> <th style="width: 20%;">Initial value</th> </tr> </thead> <tbody> <tr> <td>___x</td> <td> <p>Target alarm selection of the other axis error warning</p> <p>Select target alarms of the other axis error warning.</p> <p>0: [AL. 24 Main circuit error] and [AL. 32 Overcurrent]</p> <p>1: All alarms</p> <p>For alarms occurring at all axes, [AL. EB The other axis error warning] will not occur regardless of alarm No.</p> </td> <td>0h</td> </tr> <tr> <td>__x_</td> <td rowspan="3">For manufacturer setting</td> <td>0h</td> </tr> <tr> <td>_x__</td> <td>0h</td> </tr> <tr> <td>x___</td> <td>0h</td> </tr> </tbody> </table> | Setting digit | Explanation | Initial value | ___x | <p>Target alarm selection of the other axis error warning</p> <p>Select target alarms of the other axis error warning.</p> <p>0: [AL. 24 Main circuit error] and [AL. 32 Overcurrent]</p> <p>1: All alarms</p> <p>For alarms occurring at all axes, [AL. EB The other axis error warning] will not occur regardless of alarm No.</p> | 0h | __x_ | For manufacturer setting | 0h | _x__ | 0h | x___ | 0h | Refer to Name and function column. | Common | | | | | | | | | | |
| Setting digit | Explanation | Initial value | | | | | | | | | | | | | | | | | | | | | | | | | |
| ___x | <p>Target alarm selection of the other axis error warning</p> <p>Select target alarms of the other axis error warning.</p> <p>0: [AL. 24 Main circuit error] and [AL. 32 Overcurrent]</p> <p>1: All alarms</p> <p>For alarms occurring at all axes, [AL. EB The other axis error warning] will not occur regardless of alarm No.</p> | 0h | | | | | | | | | | | | | | | | | | | | | | | | | |
| __x_ | For manufacturer setting | 0h | | | | | | | | | | | | | | | | | | | | | | | | | |
| _x__ | | 0h | | | | | | | | | | | | | | | | | | | | | | | | | |
| x___ | | 0h | | | | | | | | | | | | | | | | | | | | | | | | | |
| PF06 | *FOP5 | <p>Function selection F-5</p> <table border="1" style="width: 100%; border-collapse: collapse;"> <thead> <tr> <th style="width: 15%;">Setting digit</th> <th style="width: 65%;">Explanation</th> <th style="width: 20%;">Initial value</th> </tr> </thead> <tbody> <tr> <td>___x</td> <td> <p>Electronic dynamic brake selection</p> <p>0: Automatic (enabled only for specified servo motors)</p> <p>2: Disabled</p> <p>Refer to the following table for the specified servo motors.</p> <table border="1" style="width: 100%; border-collapse: collapse; margin: 5px 0;"> <thead> <tr> <th style="width: 20%;">Series</th> <th>Servo motor</th> </tr> </thead> <tbody> <tr> <td>HG-KR</td> <td>HG-KR053/HG-KR13/HG-KR23/HG-KR43</td> </tr> <tr> <td>HG-MR</td> <td>HG-MR053/HG-MR13/HG-MR23/HG-MR43</td> </tr> <tr> <td>HG-SR</td> <td>HG-SR51/HG-SR52</td> </tr> <tr> <td>HG-AK</td> <td>HG-AK0136/HG-AK0236/HG-AK0336</td> </tr> </tbody> </table> </td> <td>0h</td> </tr> <tr> <td>__x_</td> <td rowspan="3">For manufacturer setting</td> <td>0h</td> </tr> <tr> <td>_x__</td> <td>0h</td> </tr> <tr> <td>x___</td> <td>0h</td> </tr> </tbody> </table> | Setting digit | Explanation | Initial value | ___x | <p>Electronic dynamic brake selection</p> <p>0: Automatic (enabled only for specified servo motors)</p> <p>2: Disabled</p> <p>Refer to the following table for the specified servo motors.</p> <table border="1" style="width: 100%; border-collapse: collapse; margin: 5px 0;"> <thead> <tr> <th style="width: 20%;">Series</th> <th>Servo motor</th> </tr> </thead> <tbody> <tr> <td>HG-KR</td> <td>HG-KR053/HG-KR13/HG-KR23/HG-KR43</td> </tr> <tr> <td>HG-MR</td> <td>HG-MR053/HG-MR13/HG-MR23/HG-MR43</td> </tr> <tr> <td>HG-SR</td> <td>HG-SR51/HG-SR52</td> </tr> <tr> <td>HG-AK</td> <td>HG-AK0136/HG-AK0236/HG-AK0336</td> </tr> </tbody> </table> | Series | Servo motor | HG-KR | HG-KR053/HG-KR13/HG-KR23/HG-KR43 | HG-MR | HG-MR053/HG-MR13/HG-MR23/HG-MR43 | HG-SR | HG-SR51/HG-SR52 | HG-AK | HG-AK0136/HG-AK0236/HG-AK0336 | 0h | __x_ | For manufacturer setting | 0h | _x__ | 0h | x___ | 0h | Refer to Name and function column. | Each |
| Setting digit | Explanation | Initial value | | | | | | | | | | | | | | | | | | | | | | | | | |
| ___x | <p>Electronic dynamic brake selection</p> <p>0: Automatic (enabled only for specified servo motors)</p> <p>2: Disabled</p> <p>Refer to the following table for the specified servo motors.</p> <table border="1" style="width: 100%; border-collapse: collapse; margin: 5px 0;"> <thead> <tr> <th style="width: 20%;">Series</th> <th>Servo motor</th> </tr> </thead> <tbody> <tr> <td>HG-KR</td> <td>HG-KR053/HG-KR13/HG-KR23/HG-KR43</td> </tr> <tr> <td>HG-MR</td> <td>HG-MR053/HG-MR13/HG-MR23/HG-MR43</td> </tr> <tr> <td>HG-SR</td> <td>HG-SR51/HG-SR52</td> </tr> <tr> <td>HG-AK</td> <td>HG-AK0136/HG-AK0236/HG-AK0336</td> </tr> </tbody> </table> | Series | Servo motor | HG-KR | HG-KR053/HG-KR13/HG-KR23/HG-KR43 | HG-MR | HG-MR053/HG-MR13/HG-MR23/HG-MR43 | HG-SR | HG-SR51/HG-SR52 | HG-AK | HG-AK0136/HG-AK0236/HG-AK0336 | 0h | | | | | | | | | | | | | | | |
| Series | Servo motor | | | | | | | | | | | | | | | | | | | | | | | | | | |
| HG-KR | HG-KR053/HG-KR13/HG-KR23/HG-KR43 | | | | | | | | | | | | | | | | | | | | | | | | | | |
| HG-MR | HG-MR053/HG-MR13/HG-MR23/HG-MR43 | | | | | | | | | | | | | | | | | | | | | | | | | | |
| HG-SR | HG-SR51/HG-SR52 | | | | | | | | | | | | | | | | | | | | | | | | | | |
| HG-AK | HG-AK0136/HG-AK0236/HG-AK0336 | | | | | | | | | | | | | | | | | | | | | | | | | | |
| __x_ | For manufacturer setting | 0h | | | | | | | | | | | | | | | | | | | | | | | | | |
| _x__ | | 0h | | | | | | | | | | | | | | | | | | | | | | | | | |
| x___ | | 0h | | | | | | | | | | | | | | | | | | | | | | | | | |
| PF12 | DBT | <p>Electronic dynamic brake operating time</p> <p>Set an operating time for the electronic dynamic brake.</p> | 2000 [ms] | 0 to 10000 | Each | | | | | | | | | | | | | | | | | | | | | | |

5. PARAMETERS

| No. | Symbol | Name and function | Initial value [unit] | Setting range | Each/ Common | | | | | | | | | | | | | |
|---------------|--------------------------------------------------------------------------------------------------------------------------------------------------------------------------------------------------------------------------------------------------------------------------------------------------------------------------------------------------------------------------------------------------------------------------------------------------------------------------------------------|-------------------------------------------------------------------------------------------------------------------------------------------------------------------------------------------------------------------------------------------------------------------------------------------------------------------------------------------------------------------------------------------------------------------------------------------------------------------------------------------------------------------------------------------------------------------------------------------------------------------------------------------------------------------------------------------------------------------------------------------------------------------------------------------------------------------------------------------------------------------------------------------------------------------------------------------------------------------------------------------------------------------------------------------------------------------------------------------------------------------------------------------------------------------------------------------------------------------------------------------------------|----------------------|------------------------------------|---------------|------|--------------------------------------------------------------------------------------------------------------------------------------------------------------------------------------------------------------------------------------------------------------------------------------------------------------------------------------------------------------------------------------------------------------------------------------------------------------------------------------------|-----------------------------------------------------------------------|-------------|-----------------------------------------------------------------------|---------|---------|-----------------------------------------------------------------------|-------------|-----------------------------------------------------------------------|------------------------------------|---------|--------|
| PF18 | **STOD | <p>STO diagnosis error detection time</p> <p>Set the time from when an error occurs in the STO input signal or STO circuit until the detection of [AL. 68.1 Mismatched STO signal error].</p> <p>When 0 s is set, the detection of [AL. 68.1 Mismatched STO signal error] is not performed.</p> <p>The following shows safety levels at the time of parameter setting.</p> <table border="1"> <thead> <tr> <th>Setting value</th> <th>STO input diagnosis by TOFB output</th> <th>Safety level</th> </tr> </thead> <tbody> <tr> <td rowspan="2">0</td> <td>Execute</td> <td>EN ISO 13849-1 Category 3 PL d, IEC 61508 SIL 2, and EN 62061 SIL CL2</td> </tr> <tr> <td>Not execute</td> <td>EN ISO 13849-1 Category 3 PL e, IEC 61508 SIL 3, and EN 62061 SIL CL3</td> </tr> <tr> <td rowspan="2">1 to 60</td> <td>Execute</td> <td>EN ISO 13849-1 Category 3 PL d, IEC 61508 SIL 2, and EN 62061 SIL CL2</td> </tr> <tr> <td>Not execute</td> <td>EN ISO 13849-1 Category 3 PL e, IEC 61508 SIL 3, and EN 62061 SIL CL3</td> </tr> </tbody> </table> <p>When the short-circuit connector is connected to the CN8 connector, set "0" in the parameter.</p> <p>This parameter is available with servo amplifiers with software version C1 or later.</p> | Setting value | STO input diagnosis by TOFB output | Safety level | 0 | Execute | EN ISO 13849-1 Category 3 PL d, IEC 61508 SIL 2, and EN 62061 SIL CL2 | Not execute | EN ISO 13849-1 Category 3 PL e, IEC 61508 SIL 3, and EN 62061 SIL CL3 | 1 to 60 | Execute | EN ISO 13849-1 Category 3 PL d, IEC 61508 SIL 2, and EN 62061 SIL CL2 | Not execute | EN ISO 13849-1 Category 3 PL e, IEC 61508 SIL 3, and EN 62061 SIL CL3 | 0 [s] | 0 to 60 | Common |
| Setting value | STO input diagnosis by TOFB output | Safety level | | | | | | | | | | | | | | | | |
| 0 | Execute | EN ISO 13849-1 Category 3 PL d, IEC 61508 SIL 2, and EN 62061 SIL CL2 | | | | | | | | | | | | | | | | |
| | Not execute | EN ISO 13849-1 Category 3 PL e, IEC 61508 SIL 3, and EN 62061 SIL CL3 | | | | | | | | | | | | | | | | |
| 1 to 60 | Execute | EN ISO 13849-1 Category 3 PL d, IEC 61508 SIL 2, and EN 62061 SIL CL2 | | | | | | | | | | | | | | | | |
| | Not execute | EN ISO 13849-1 Category 3 PL e, IEC 61508 SIL 3, and EN 62061 SIL CL3 | | | | | | | | | | | | | | | | |
| PF21 | DRT | <p>Drive recorder switching time setting</p> <p>Set a drive recorder switching time.</p> <p>When a USB communication is cut during using a graph function, the function will be changed to the drive recorder function after the setting time of this parameter.</p> <p>When a value from "1" to "32767" is set, it will switch after the setting value.</p> <p>However, when "0" is set, it will switch after 600 seconds.</p> <p>When "-1" is set, the drive recorder function is disabled.</p> | 0 [s] | -1 to 32767 | Common | | | | | | | | | | | | | |
| PF23 | OSCL1 | <p>Vibration tough drive - Oscillation detection level</p> <p>Set a filter readjustment sensitivity of [Pr. PB13 Machine resonance suppression filter 1] and [Pr. PB15 Machine resonance suppression filter 2] while the vibration tough drive is enabled.</p> <p>However, setting "0" will be 50%.</p> <p>Example: When you set "50" to the parameter, the filter will be readjusted at the time of 50% or more oscillation level.</p> | 50 [%] | 0 to 100 | Each | | | | | | | | | | | | | |
| PF24 | *OSCL2 | <p>Vibration tough drive function selection</p> <table border="1"> <thead> <tr> <th>Setting digit</th> <th>Explanation</th> <th>Initial value</th> </tr> </thead> <tbody> <tr> <td>___x</td> <td> <p>Oscillation detection alarm selection</p> <p>0: [AL. 54 Oscillation detection] will occur at oscillation detection.</p> <p>1: [AL. F3.1 Oscillation detection warning] will occur at oscillation detection.</p> <p>2: Oscillation detection function disabled</p> <p>Select alarm or warning when a oscillation continues at a filter readjustment sensitivity level of [Pr. PF23].</p> <p>The digit is continuously enabled regardless of the vibration tough drive in [Pr. PA20].</p> </td> <td>0h</td> </tr> <tr> <td>__x__</td> <td rowspan="3">For manufacturer setting</td> <td>0h</td> </tr> <tr> <td>_x__</td> <td>0h</td> </tr> <tr> <td>x___</td> <td>0h</td> </tr> </tbody> </table> | Setting digit | Explanation | Initial value | ___x | <p>Oscillation detection alarm selection</p> <p>0: [AL. 54 Oscillation detection] will occur at oscillation detection.</p> <p>1: [AL. F3.1 Oscillation detection warning] will occur at oscillation detection.</p> <p>2: Oscillation detection function disabled</p> <p>Select alarm or warning when a oscillation continues at a filter readjustment sensitivity level of [Pr. PF23].</p> <p>The digit is continuously enabled regardless of the vibration tough drive in [Pr. PA20].</p> | 0h | __x__ | For manufacturer setting | 0h | _x__ | 0h | x___ | 0h | Refer to Name and function column. | Each | |
| Setting digit | Explanation | Initial value | | | | | | | | | | | | | | | | |
| ___x | <p>Oscillation detection alarm selection</p> <p>0: [AL. 54 Oscillation detection] will occur at oscillation detection.</p> <p>1: [AL. F3.1 Oscillation detection warning] will occur at oscillation detection.</p> <p>2: Oscillation detection function disabled</p> <p>Select alarm or warning when a oscillation continues at a filter readjustment sensitivity level of [Pr. PF23].</p> <p>The digit is continuously enabled regardless of the vibration tough drive in [Pr. PA20].</p> | 0h | | | | | | | | | | | | | | | | |
| __x__ | For manufacturer setting | 0h | | | | | | | | | | | | | | | | |
| _x__ | | 0h | | | | | | | | | | | | | | | | |
| x___ | | 0h | | | | | | | | | | | | | | | | |

5. PARAMETERS

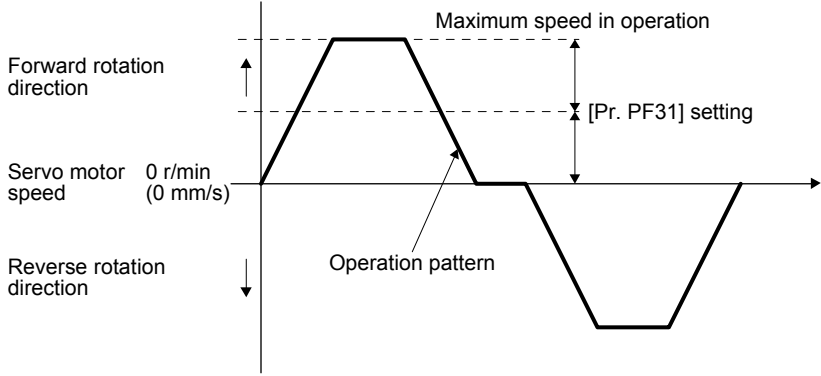
| No. | Symbol | Name and function | Initial value [unit] | Setting range | Each/ Common |
|------|--------|------------------------------------------------------------------------------------------------------------------------------------------------------------------------------------------------------------------------------------------------------------------------------------------------------------------------------------------------------------------------------------------------------------------------------------------------------------------------------------------------------------------------------------------------------------------------------------------------------------------------------------------------------------------------------------------------------------------------------------------------------------------------------------------------------------------------------------------------------------------------------------------------------------------------------------------------------------------------------------------------------------------------------------------|----------------------|------------------------|--------------|
| PF25 | CVAT | <p>SEMI-F47 function - Instantaneous power failure detection time</p> <p>Set the time of the [AL. 10.1 Voltage drop in the control circuit power] occurrence.</p> <p>This parameter setting range differs depending on the software version of the servo amplifier as follows.</p> <ul style="list-style-type: none"> • Software version C0 or later: Setting range 30 ms to 200 ms • Software version C1 or earlier: Setting range 30 ms to 500 ms <p>To comply with SEMI-F47 standard, it is unnecessary to change the initial value (200 ms).</p> <p>However, when the instantaneous power failure time exceeds 200 ms, and the instantaneous power failure voltage is less than 70% of the rated input voltage, the power may be normally turned off even if a value larger than 200 ms is set in the parameter.</p> <p>To disable the parameter, select "Disabled (_ 0 _)" of "SEMI-F47 function selection" in [Pr. PA20].</p> <p>This parameter is not available with MR-J4W2-0303B6 servo amplifiers.</p> | 200 [ms] | 30 to 500 | Common |
| PF31 | FRIC | <p>Machine diagnosis function - Friction judgment speed</p> <p>Set a (linear) servo motor speed that divides a friction estimation area into high and low during the friction estimation process of the machine diagnosis.</p> <p>However, setting "0" will be the value half of the rated speed.</p> <p>When your operation pattern is under rated speed, we recommend that you set half value to the maximum speed with this.</p>  | 0 [r/min]/ [mm/s] | 0 to permissible speed | Each axis |

5. PARAMETERS

5.2.7 Linear servo motor/DD motor setting parameters ([Pr. PL_ _])

| |
|-----------------------------------------------------------------------------------------------------------------------------|
| POINT |
| <p>● Linear servo motor/DD motor setting parameters ([Pr. PL_ _]) cannot be used with MR-J4W2-0303B6 servo amplifiers.</p> |

| No. | Symbol | Name and function | Initial value [unit] | Setting range | Each/ Common | | | | | | | | | | | | | | | |
|---------------|-------------------------------------------------------------------------------------------------------------------------------------------------------------------------------------------------------------------------------------------------------------------------------------------------------------------------------------------------------------------------------------------------------------------------------------------------------------------------------------------------------------------|-----------------------------------------------------------------------------------------------------------------------------------------------------------------------------------------------------------------------------------------------------------------------------------------------------------------------------------------------------------------------------------------------------------------------------------------------------------------------------------------------------------------------------------------------------------------------------------------------------------------------------------------------------------------------------------------------------------------------------------------------------------------------------------------------------------------------------------------------------------------------------------------------------------------------------------------------------------------------------------------------------------------------------------------------------------------------------------------------------------------------------------------------------------------------------------------------------------------------------------------------------------------------------------------------------------------------------------------------------------------------------------------------------------------------------------------------------------------------------------------------------------------------------------------------------------------------------------------------------------------------------------------------------------------------------------------------------------------------------------------------------------------------------|----------------------|---------------|---------------|---------|-------------------------------------------------------------------------------------------------------------------------------------------------------------------------------------------------------------------------------------------------------------------------------------------------------------|----|---------|--------------------------|----|---------|-------------------------------------------------------------------------------------------------------------------------------------------------------------------------------------------------------------------------------------------------------------------------------------------------------------------------------------------------------------------------------------------------------------------------------------------------------------------------------------------------------------------|----|---------|--------------------------|----|------------------------------------|--|------|
| PL01 | **LIT1 | <p>Linear servo motor/DD motor function selection 1</p> <p>Select a magnetic pole detection timing of the linear servo motor/DD motor and stop interval of the home position returning.</p> <table border="1" style="width: 100%; border-collapse: collapse;"> <thead> <tr> <th style="width: 15%;">Setting digit</th> <th style="width: 65%;">Explanation</th> <th style="width: 20%;">Initial value</th> </tr> </thead> <tbody> <tr> <td style="text-align: center;">_ _ _ x</td> <td> <p>Linear servo motor/DD motor magnetic pole detection selection</p> <p>The setting value "0" will be enabled only with absolute position linear encoders.</p> <p>0: Magnetic pole detection disabled 1: Magnetic pole detection at first servo-on 5: Magnetic pole detection at every servo-on</p> </td> <td style="text-align: center;">1h</td> </tr> <tr> <td style="text-align: center;">_ _ x _</td> <td>For manufacturer setting</td> <td style="text-align: center;">0h</td> </tr> <tr> <td style="text-align: center;">_ x _ _</td> <td> <p>Stop interval selection at the home position return</p> <p>Set a stop interval of the home position returning.</p> <p>The digit is enabled only for linear servo motors.</p> <p>0: 2^{13} (= 8192) pulses 1: 2^{17} (= 131072) pulses 2: 2^{18} (= 262144) pulses 3: 2^{20} (= 1048576) pulses 4: 2^{22} (= 4194304) pulses 5: 2^{24} (= 16777216) pulses 6: 2^{26} (= 67108864) pulses</p> </td> <td style="text-align: center;">3h</td> </tr> <tr> <td style="text-align: center;">x _ _ _</td> <td>For manufacturer setting</td> <td style="text-align: center;">0h</td> </tr> </tbody> </table> | Setting digit | Explanation | Initial value | _ _ _ x | <p>Linear servo motor/DD motor magnetic pole detection selection</p> <p>The setting value "0" will be enabled only with absolute position linear encoders.</p> <p>0: Magnetic pole detection disabled 1: Magnetic pole detection at first servo-on 5: Magnetic pole detection at every servo-on</p> | 1h | _ _ x _ | For manufacturer setting | 0h | _ x _ _ | <p>Stop interval selection at the home position return</p> <p>Set a stop interval of the home position returning.</p> <p>The digit is enabled only for linear servo motors.</p> <p>0: 2^{13} (= 8192) pulses 1: 2^{17} (= 131072) pulses 2: 2^{18} (= 262144) pulses 3: 2^{20} (= 1048576) pulses 4: 2^{22} (= 4194304) pulses 5: 2^{24} (= 16777216) pulses 6: 2^{26} (= 67108864) pulses</p> | 3h | x _ _ _ | For manufacturer setting | 0h | Refer to Name and function column. | | Each |
| Setting digit | Explanation | Initial value | | | | | | | | | | | | | | | | | | |
| _ _ _ x | <p>Linear servo motor/DD motor magnetic pole detection selection</p> <p>The setting value "0" will be enabled only with absolute position linear encoders.</p> <p>0: Magnetic pole detection disabled 1: Magnetic pole detection at first servo-on 5: Magnetic pole detection at every servo-on</p> | 1h | | | | | | | | | | | | | | | | | | |
| _ _ x _ | For manufacturer setting | 0h | | | | | | | | | | | | | | | | | | |
| _ x _ _ | <p>Stop interval selection at the home position return</p> <p>Set a stop interval of the home position returning.</p> <p>The digit is enabled only for linear servo motors.</p> <p>0: 2^{13} (= 8192) pulses 1: 2^{17} (= 131072) pulses 2: 2^{18} (= 262144) pulses 3: 2^{20} (= 1048576) pulses 4: 2^{22} (= 4194304) pulses 5: 2^{24} (= 16777216) pulses 6: 2^{26} (= 67108864) pulses</p> | 3h | | | | | | | | | | | | | | | | | | |
| x _ _ _ | For manufacturer setting | 0h | | | | | | | | | | | | | | | | | | |
| PL02 | **LIM | <p>Linear encoder resolution - Numerator</p> <p>Set a linear encoder resolution in [Pr. PL02] and [Pr. PL03].</p> <p>Set the numerator in [Pr. PL02].</p> <p>This is enabled only for linear servo motors.</p> | 1000 [μm] | 1 to 65535 | Each | | | | | | | | | | | | | | | |
| PL03 | **LID | <p>Linear encoder resolution - Denominator</p> <p>Set a linear encoder resolution in [Pr. PL02] and [Pr. PL03].</p> <p>Set the denominator in [Pr. PL03].</p> <p>This is enabled only for linear servo motors.</p> | 1000 [μm] | 1 to 65535 | Each | | | | | | | | | | | | | | | |

5. PARAMETERS

| No. | Symbol | Name and function | Initial value [unit] | Setting range | Each/ Common | | | | | | | | | | | | | | | | | | | | | | | | | | | | | | | | | | | | | | | | | | | |
|---------------|-------------------------------------------------------------------------------------------------------------------------------------------------------------------------------------------------------------------------------------------------------------------------------------------------------------------------------------------------------------------------------------------------------------------------------------------------------------------------------------------------------------------------------------------------------------------------------------------------------------------------------------------------------------------------------------------------------------------------------------------------------------------------------------------------------------------------------------------------------------------------------------------------------------------------------------------------------|------------------------------------------------------------------------------------------------------------------------------------------------------------------------------------------------------------------------------------------------------------------------------------------------------------------------------------------------------------------------------------------------------------------------------------------------------------------------------------------------------------------------------------------------------------------------------------------------------------------------------------------------------------------------------------------------------------------------------------------------------------------------------------------------------------------------------------------------------------------------------------------------------------------------------------------------------------------------------------------------------------------------------------------------------------------------------------------------------------------------------------------------------------------------------------------------------------------------------------------------------------------------------------------------------------------------------------------------------------------------------------------------------------------------------------------------------------------------------------------------------------------------------------------------------------------------------------------------------------------------------------------------------------------------------|--------------------------------------|------------------------------|---------------------------------|-------|-------------------------------------------------------------------------------------------------------------------------------------------------------------------------------------------------------------------------------------------------------------------------------------------------------------------------------------------------------------------------------------------------------------------------------------------------------------------------------------------------------------------------------------------------------------------------------------------------------------------------------------------------------------------------------------------------------------------------------------------------------------------------------------------------------------------------------------------------------------------------------------------------------------------------------------------------------|---------------|--------------------------------------|------------------------------|---------------------------------|---------|----------|----------|----------|---|---------|----------|----------|----------|---------|---------|----------|----------|----------|---------|---------|---|----------|---------|---|----------|---------|----|---------|---------|----|--------|--------------------------|----|---------|--|----|---------|---------------------------------------------------------------------------------------------------------------------------------------------------------------------------|----|------------------------------------|------|
| PL04 | *LIT2 | <p>Linear servo motor/DD motor function selection 2 Select a detection function and detection controller reset condition of [AL. 42 Servo control error].</p> <table border="1"> <thead> <tr> <th>Setting digit</th> <th>Explanation</th> <th>Initial value</th> </tr> </thead> <tbody> <tr> <td>___ x</td> <td> <p>[AL. 42 Servo control error] detection function selection Refer to the following table.</p> <table border="1"> <thead> <tr> <th>Setting value</th> <th>Torque/thrust deviation error (Note)</th> <th>Speed deviation error (Note)</th> <th>Position deviation error (Note)</th> </tr> </thead> <tbody> <tr> <td>0</td> <td rowspan="3">Disabled</td> <td>Disabled</td> <td>Disabled</td> </tr> <tr> <td>1</td> <td rowspan="2">Enabled</td> <td>Enabled</td> </tr> <tr> <td>2</td> <td>Disabled</td> </tr> <tr> <td>3</td> <td rowspan="4">Enabled</td> <td>Disabled</td> <td>Disabled</td> </tr> <tr> <td>4</td> <td rowspan="3">Enabled</td> <td>Enabled</td> </tr> <tr> <td>5</td> <td>Disabled</td> <td>Enabled</td> </tr> <tr> <td>6</td> <td>Disabled</td> <td>Enabled</td> </tr> <tr> <td>7</td> <td>Enabled</td> <td>Enabled</td> </tr> </tbody> </table> <p>Note. Refer to chapter 14 and 15 for details of each deviation error.</p> </td> <td>3h</td> </tr> <tr> <td>__ x _</td> <td>For manufacturer setting</td> <td>0h</td> </tr> <tr> <td>_ x _ _</td> <td></td> <td>0h</td> </tr> <tr> <td>x _ _ _</td> <td> <p>[AL. 42 Servo control error] detection function controller reset condition selection 0: Reset disabled (reset by powering off/on enabled) 1: Reset enabled</p> </td> <td>0h</td> </tr> </tbody> </table> | Setting digit | Explanation | Initial value | ___ x | <p>[AL. 42 Servo control error] detection function selection Refer to the following table.</p> <table border="1"> <thead> <tr> <th>Setting value</th> <th>Torque/thrust deviation error (Note)</th> <th>Speed deviation error (Note)</th> <th>Position deviation error (Note)</th> </tr> </thead> <tbody> <tr> <td>0</td> <td rowspan="3">Disabled</td> <td>Disabled</td> <td>Disabled</td> </tr> <tr> <td>1</td> <td rowspan="2">Enabled</td> <td>Enabled</td> </tr> <tr> <td>2</td> <td>Disabled</td> </tr> <tr> <td>3</td> <td rowspan="4">Enabled</td> <td>Disabled</td> <td>Disabled</td> </tr> <tr> <td>4</td> <td rowspan="3">Enabled</td> <td>Enabled</td> </tr> <tr> <td>5</td> <td>Disabled</td> <td>Enabled</td> </tr> <tr> <td>6</td> <td>Disabled</td> <td>Enabled</td> </tr> <tr> <td>7</td> <td>Enabled</td> <td>Enabled</td> </tr> </tbody> </table> <p>Note. Refer to chapter 14 and 15 for details of each deviation error.</p> | Setting value | Torque/thrust deviation error (Note) | Speed deviation error (Note) | Position deviation error (Note) | 0 | Disabled | Disabled | Disabled | 1 | Enabled | Enabled | 2 | Disabled | 3 | Enabled | Disabled | Disabled | 4 | Enabled | Enabled | 5 | Disabled | Enabled | 6 | Disabled | Enabled | 7 | Enabled | Enabled | 3h | __ x _ | For manufacturer setting | 0h | _ x _ _ | | 0h | x _ _ _ | <p>[AL. 42 Servo control error] detection function controller reset condition selection 0: Reset disabled (reset by powering off/on enabled) 1: Reset enabled</p> | 0h | Refer to Name and function column. | Each |
| Setting digit | Explanation | Initial value | | | | | | | | | | | | | | | | | | | | | | | | | | | | | | | | | | | | | | | | | | | | | | |
| ___ x | <p>[AL. 42 Servo control error] detection function selection Refer to the following table.</p> <table border="1"> <thead> <tr> <th>Setting value</th> <th>Torque/thrust deviation error (Note)</th> <th>Speed deviation error (Note)</th> <th>Position deviation error (Note)</th> </tr> </thead> <tbody> <tr> <td>0</td> <td rowspan="3">Disabled</td> <td>Disabled</td> <td>Disabled</td> </tr> <tr> <td>1</td> <td rowspan="2">Enabled</td> <td>Enabled</td> </tr> <tr> <td>2</td> <td>Disabled</td> </tr> <tr> <td>3</td> <td rowspan="4">Enabled</td> <td>Disabled</td> <td>Disabled</td> </tr> <tr> <td>4</td> <td rowspan="3">Enabled</td> <td>Enabled</td> </tr> <tr> <td>5</td> <td>Disabled</td> <td>Enabled</td> </tr> <tr> <td>6</td> <td>Disabled</td> <td>Enabled</td> </tr> <tr> <td>7</td> <td>Enabled</td> <td>Enabled</td> </tr> </tbody> </table> <p>Note. Refer to chapter 14 and 15 for details of each deviation error.</p> | Setting value | Torque/thrust deviation error (Note) | Speed deviation error (Note) | Position deviation error (Note) | 0 | Disabled | Disabled | Disabled | 1 | Enabled | Enabled | | 2 | Disabled | 3 | Enabled | Disabled | Disabled | 4 | Enabled | | Enabled | 5 | Disabled | | Enabled | 6 | Disabled | Enabled | 7 | Enabled | Enabled | 3h | | | | | | | | | | | | | | |
| Setting value | Torque/thrust deviation error (Note) | Speed deviation error (Note) | Position deviation error (Note) | | | | | | | | | | | | | | | | | | | | | | | | | | | | | | | | | | | | | | | | | | | | | |
| 0 | Disabled | Disabled | Disabled | | | | | | | | | | | | | | | | | | | | | | | | | | | | | | | | | | | | | | | | | | | | | |
| 1 | | Enabled | Enabled | | | | | | | | | | | | | | | | | | | | | | | | | | | | | | | | | | | | | | | | | | | | | |
| 2 | | | Disabled | | | | | | | | | | | | | | | | | | | | | | | | | | | | | | | | | | | | | | | | | | | | | |
| 3 | Enabled | Disabled | Disabled | | | | | | | | | | | | | | | | | | | | | | | | | | | | | | | | | | | | | | | | | | | | | |
| 4 | | Enabled | Enabled | | | | | | | | | | | | | | | | | | | | | | | | | | | | | | | | | | | | | | | | | | | | | |
| 5 | | | Disabled | Enabled | | | | | | | | | | | | | | | | | | | | | | | | | | | | | | | | | | | | | | | | | | | | |
| 6 | | | Disabled | Enabled | | | | | | | | | | | | | | | | | | | | | | | | | | | | | | | | | | | | | | | | | | | | |
| 7 | Enabled | Enabled | | | | | | | | | | | | | | | | | | | | | | | | | | | | | | | | | | | | | | | | | | | | | | |
| __ x _ | For manufacturer setting | 0h | | | | | | | | | | | | | | | | | | | | | | | | | | | | | | | | | | | | | | | | | | | | | | |
| _ x _ _ | | 0h | | | | | | | | | | | | | | | | | | | | | | | | | | | | | | | | | | | | | | | | | | | | | | |
| x _ _ _ | <p>[AL. 42 Servo control error] detection function controller reset condition selection 0: Reset disabled (reset by powering off/on enabled) 1: Reset enabled</p> | 0h | | | | | | | | | | | | | | | | | | | | | | | | | | | | | | | | | | | | | | | | | | | | | | |
| PL05 | LB1 | <p>Position deviation error detection level Set a position deviation error detection level of the servo control error detection. When the deviation between a model feedback position and actual feedback position is larger than the setting value, [AL. 42 Servo control error] will occur. However, when "0" is set, the level vary depending on the operation mode in [Pr. PA01]. Linear servo motor: 50 mm Direct drive motor: 0.09 rev</p> | 0 [mm]/ [0.01 rev] | 0 to 1000 | Each | | | | | | | | | | | | | | | | | | | | | | | | | | | | | | | | | | | | | | | | | | | |
| PL06 | LB2 | <p>Speed deviation error detection level Set a speed deviation error detection level of the servo control error detection. When the deviation between a model feedback speed and actual feedback speed is larger than the setting value, [AL. 42 Servo control error] will occur. However, when "0" is set, the level vary depending on the operation mode in [Pr. PA01]. Linear servo motor: 1000 mm/s Direct drive motor: 100 r/min</p> | 0 [mm/s]/ [r/min] | 0 to 5000 | Each | | | | | | | | | | | | | | | | | | | | | | | | | | | | | | | | | | | | | | | | | | | |
| PL07 | LB3 | <p>Torque/thrust deviation error detection level Set a torque/thrust deviation error detection level of the servo control error detection. When the deviation between a current command and current feedback is larger than the setting value, [AL. 42.3 Servo control error by torque/thrust deviation] will occur.</p> | 100 [%] | 0 to 1000 | Each | | | | | | | | | | | | | | | | | | | | | | | | | | | | | | | | | | | | | | | | | | | |

5. PARAMETERS

| No. | Symbol | Name and function | Initial value [unit] | Setting range | Each/ Common | | | | | | | | | | | | | | | |
|------|--------|--------------------------------------------------------------------------------------------------------------------------------------------------------------------------------------------------------------------------------------------------------------------------------------------------------------------------------------------------------------------------------------------------------------------------------------------------------------------------------------------------------------------------------------------------------------------------------------------------------------------------------------------------------------------------------------------------------------------------------------------------------------------------|----------------------|-----------------------------------------------------------------------------------------------------------------|---------------|------|-----------------------------------------------------------------------------------------------------------------|----|------|--------------------------|----|------|------------------------------------------------------------------------------------------------|----|------|--------------------------|----|------------------------------------|--|------|
| PL08 | *LIT3 | Linear servo motor/DD motor function selection 3 <table border="1" style="width: 100%; border-collapse: collapse;"> <thead> <tr> <th style="width: 15%;">Setting digit</th> <th style="width: 65%;">Explanation</th> <th style="width: 20%;">Initial value</th> </tr> </thead> <tbody> <tr> <td>___x</td> <td>Magnetic pole detection method selection 0: Position detection method 4: Minute position detection method</td> <td>0h</td> </tr> <tr> <td>__x_</td> <td>For manufacturer setting</td> <td>1h</td> </tr> <tr> <td>_x__</td> <td>Magnetic pole detection - Stroke limit enabled/disabled selection 0: Enabled 1: Disabled</td> <td>0h</td> </tr> <tr> <td>x___</td> <td>For manufacturer setting</td> <td>0h</td> </tr> </tbody> </table> | Setting digit | Explanation | Initial value | ___x | Magnetic pole detection method selection 0: Position detection method 4: Minute position detection method | 0h | __x_ | For manufacturer setting | 1h | _x__ | Magnetic pole detection - Stroke limit enabled/disabled selection 0: Enabled 1: Disabled | 0h | x___ | For manufacturer setting | 0h | Refer to Name and function column. | | Each |
| | | | Setting digit | Explanation | Initial value | | | | | | | | | | | | | | | |
| | | | ___x | Magnetic pole detection method selection 0: Position detection method 4: Minute position detection method | 0h | | | | | | | | | | | | | | | |
| | | | __x_ | For manufacturer setting | 1h | | | | | | | | | | | | | | | |
| | | | _x__ | Magnetic pole detection - Stroke limit enabled/disabled selection 0: Enabled 1: Disabled | 0h | | | | | | | | | | | | | | | |
| | | | x___ | For manufacturer setting | 0h | | | | | | | | | | | | | | | |
| PL09 | LPWM | Magnetic pole detection voltage level Set a direct current exciting voltage level during the magnetic pole detection. If [AL. 32 Overcurrent], [AL. 50 Overload 1], or [AL. 51 Overload 2] occurs during the magnetic pole detection, decrease the setting value. If [AL. 27 Initial magnetic pole detection error] occurs during the magnetic pole detection, increase the setting value. | 30 [%] | 0 to 100 | Each | | | | | | | | | | | | | | | |

5. PARAMETERS

| No. | Symbol | Name and function | Initial value [unit] | Setting range | Each/ Common | | | | | | | | | | | | | | | | | | | | | | | | | | | | | | | | | | | |
|---------------------------------------------------------------------------------------------------------------------------------------------------------------------------------------------------------------------------------------------------------------------------------------------------------------------------------------------------------------------------------------------------------------------------------------------------------------------------------------------------------------------------------------------------------------------------------------------------------------------------------------------------------------------------------------------------------------------------------------------------------------------------------------------------------------------------------------------------------------------------------------------------------------------------------------------------------------------------------------------------------|------------------------------------------------------|----------------------------------------------------------------------------------------------------------------------------------------------------------------------------------------------------------------------------------------------------------------------------------------------------------------------------------------------------------------------------------------------------------------------------------------------------------------------------------------------------------------------------------------------------------------------------------------------------------------------------------------------------------------------------------------------------------------------------------------------------------------------------------|------------------------------------------------------|---------------|------------------------------------------------------------------------------------------------------------------------------------------------------------------------------------------------------------------------------------------------------------------------------------------------------------------------------------------------------------------------------------------------------------------------------------------------------------------------------------------------------------------------------------------------------------------------------------------------------------------------------------------------------------------------------------------------------------------------------------------------------------------------------------------------------------------------------------------------------------------------------------------------------------|------------------------------------------------------|--------------------------------------------|------------------------------------------------------|---------------|------------------------------------------------------------------------------------------------------------------------------------------------------------------------------------------------------------|--------|-------------------------------------------|----------------------------------------------------------------------------------------------------------------------------------------------------------------------------------------------------------------------------------------------------------------------------------------------------------------------|--------------------------------------------|---------|--------------------------|--------|----------|--------|-----------|--------|----------|--------|-----------|--------|----------|--------|-----------------|--------|---------------|--------|-----------|--------|----------|--------|-----------|--------|----------|--------|-------------------|
| PL17 | LTSTS | Magnetic pole detection - Minute position detection method - Function selection To enable the parameter, select "Minute position detection method (_ _ _ 4)" in [Pr. PL08]. | Refer to Name and function column. | Each | <table border="1"> <thead> <tr> <th>Setting digit</th> <th>Explanation</th> <th>Initial value</th> </tr> </thead> <tbody> <tr> <td>___ x</td> <td>Response selection Set a response of the minute position detection method. When reducing a travel distance at the magnetic pole detection, increase the setting value. Refer to table 5.9 for settings.</td> <td>0h</td> </tr> <tr> <td>__ x _</td> <td>Load to motor mass ratio/load to motor inertia ratio selection Select a load to mass of the linear servo motor primary-side ratio or load to mass of the direct drive motor inertia ratio used at the minute position detection method. Set a closest value to the actual load. Refer to table 5.10 for settings.</td> <td>0h</td> </tr> <tr> <td>_ x _ _</td> <td rowspan="2">For manufacturer setting</td> <td>0h</td> </tr> <tr> <td>x _ _ _</td> <td>0h</td> </tr> </tbody> </table> | Setting digit | Explanation | Initial value | ___ x | Response selection Set a response of the minute position detection method. When reducing a travel distance at the magnetic pole detection, increase the setting value. Refer to table 5.9 for settings. | 0h | __ x _ | Load to motor mass ratio/load to motor inertia ratio selection Select a load to mass of the linear servo motor primary-side ratio or load to mass of the direct drive motor inertia ratio used at the minute position detection method. Set a closest value to the actual load. Refer to table 5.10 for settings. | 0h | _ x _ _ | For manufacturer setting | 0h | x _ _ _ | 0h | | | | | | | | | | | | | | | | | | | | | |
| | | Setting digit | | | Explanation | Initial value | | | | | | | | | | | | | | | | | | | | | | | | | | | | | | | | | | |
| | | ___ x | | | Response selection Set a response of the minute position detection method. When reducing a travel distance at the magnetic pole detection, increase the setting value. Refer to table 5.9 for settings. | 0h | | | | | | | | | | | | | | | | | | | | | | | | | | | | | | | | | | |
| | | __ x _ | | | Load to motor mass ratio/load to motor inertia ratio selection Select a load to mass of the linear servo motor primary-side ratio or load to mass of the direct drive motor inertia ratio used at the minute position detection method. Set a closest value to the actual load. Refer to table 5.10 for settings. | 0h | | | | | | | | | | | | | | | | | | | | | | | | | | | | | | | | | | |
| | | _ x _ _ | | | For manufacturer setting | 0h | | | | | | | | | | | | | | | | | | | | | | | | | | | | | | | | | | |
| | | x _ _ _ | | | | 0h | | | | | | | | | | | | | | | | | | | | | | | | | | | | | | | | | | |
| | | <p>Table 5.9 Response of minute position detection method at magnetic pole detection</p> <table border="1"> <thead> <tr> <th>Setting value</th> <th>Response</th> <th>Setting value</th> <th>Response</th> </tr> </thead> <tbody> <tr> <td>___ 0</td> <td rowspan="7">Low response ↑ ↓ Middle response</td> <td>___ 8</td> <td rowspan="7">Middle response ↑ ↓ High response</td> </tr> <tr> <td>___ 1</td> <td>___ 9</td> </tr> <tr> <td>___ 2</td> <td>___ A</td> </tr> <tr> <td>___ 3</td> <td>___ B</td> </tr> <tr> <td>___ 4</td> <td>___ C</td> </tr> <tr> <td>___ 5</td> <td>___ D</td> </tr> <tr> <td>___ 6</td> <td>___ E</td> </tr> <tr> <td>___ 7</td> <td>Middle response</td> <td>___ F</td> <td>High response</td> </tr> </tbody> </table> | | | | | Setting value | Response | Setting value | Response | ___ 0 | Low response ↑ ↓ Middle response | ___ 8 | Middle response ↑ ↓ High response | ___ 1 | ___ 9 | ___ 2 | ___ A | ___ 3 | ___ B | ___ 4 | ___ C | ___ 5 | ___ D | ___ 6 | ___ E | ___ 7 | Middle response | ___ F | High response | | | | | | | | | | |
| | | Setting value | | | Response | Setting value | Response | | | | | | | | | | | | | | | | | | | | | | | | | | | | | | | | | |
| | | ___ 0 | | | Low response ↑ ↓ Middle response | ___ 8 | Middle response ↑ ↓ High response | | | | | | | | | | | | | | | | | | | | | | | | | | | | | | | | | |
| | | ___ 1 | | | | ___ 9 | | | | | | | | | | | | | | | | | | | | | | | | | | | | | | | | | | |
| ___ 2 | ___ A | | | | | | | | | | | | | | | | | | | | | | | | | | | | | | | | | | | | | | | |
| ___ 3 | ___ B | | | | | | | | | | | | | | | | | | | | | | | | | | | | | | | | | | | | | | | |
| ___ 4 | ___ C | | | | | | | | | | | | | | | | | | | | | | | | | | | | | | | | | | | | | | | |
| ___ 5 | ___ D | | | | | | | | | | | | | | | | | | | | | | | | | | | | | | | | | | | | | | | |
| ___ 6 | ___ E | | | | | | | | | | | | | | | | | | | | | | | | | | | | | | | | | | | | | | | |
| ___ 7 | Middle response | ___ F | High response | | | | | | | | | | | | | | | | | | | | | | | | | | | | | | | | | | | | | |
| <p>Table 5.10 Load to motor mass ratio/load to motor inertia ratio</p> <table border="1"> <thead> <tr> <th>Setting value</th> <th>Load to motor mass ratio/load to motor inertia ratio</th> <th>Setting value</th> <th>Load to motor mass ratio/load to motor inertia ratio</th> </tr> </thead> <tbody> <tr> <td>__ 0 _</td> <td>10 times or less</td> <td>__ 8 _</td> <td>80 times</td> </tr> <tr> <td>__ 1 _</td> <td>10 times</td> <td>__ 9 _</td> <td>90 times</td> </tr> <tr> <td>__ 2 _</td> <td>20 times</td> <td>__ A _</td> <td>100 times</td> </tr> <tr> <td>__ 3 _</td> <td>30 times</td> <td>__ B _</td> <td>110 times</td> </tr> <tr> <td>__ 4 _</td> <td>40 times</td> <td>__ C _</td> <td>120 times</td> </tr> <tr> <td>__ 5 _</td> <td>50 times</td> <td>__ D _</td> <td>130 times</td> </tr> <tr> <td>__ 6 _</td> <td>60 times</td> <td>__ E _</td> <td>140 times</td> </tr> <tr> <td>__ 7 _</td> <td>70 times</td> <td>__ F _</td> <td>150 times or more</td> </tr> </tbody> </table> | | | | | Setting value | Load to motor mass ratio/load to motor inertia ratio | Setting value | Load to motor mass ratio/load to motor inertia ratio | __ 0 _ | 10 times or less | __ 8 _ | 80 times | __ 1 _ | 10 times | __ 9 _ | 90 times | __ 2 _ | 20 times | __ A _ | 100 times | __ 3 _ | 30 times | __ B _ | 110 times | __ 4 _ | 40 times | __ C _ | 120 times | __ 5 _ | 50 times | __ D _ | 130 times | __ 6 _ | 60 times | __ E _ | 140 times | __ 7 _ | 70 times | __ F _ | 150 times or more |
| Setting value | Load to motor mass ratio/load to motor inertia ratio | Setting value | Load to motor mass ratio/load to motor inertia ratio | | | | | | | | | | | | | | | | | | | | | | | | | | | | | | | | | | | | | |
| __ 0 _ | 10 times or less | __ 8 _ | 80 times | | | | | | | | | | | | | | | | | | | | | | | | | | | | | | | | | | | | | |
| __ 1 _ | 10 times | __ 9 _ | 90 times | | | | | | | | | | | | | | | | | | | | | | | | | | | | | | | | | | | | | |
| __ 2 _ | 20 times | __ A _ | 100 times | | | | | | | | | | | | | | | | | | | | | | | | | | | | | | | | | | | | | |
| __ 3 _ | 30 times | __ B _ | 110 times | | | | | | | | | | | | | | | | | | | | | | | | | | | | | | | | | | | | | |
| __ 4 _ | 40 times | __ C _ | 120 times | | | | | | | | | | | | | | | | | | | | | | | | | | | | | | | | | | | | | |
| __ 5 _ | 50 times | __ D _ | 130 times | | | | | | | | | | | | | | | | | | | | | | | | | | | | | | | | | | | | | |
| __ 6 _ | 60 times | __ E _ | 140 times | | | | | | | | | | | | | | | | | | | | | | | | | | | | | | | | | | | | | |
| __ 7 _ | 70 times | __ F _ | 150 times or more | | | | | | | | | | | | | | | | | | | | | | | | | | | | | | | | | | | | | |
| PL18 | IDLV | Magnetic pole detection - Minute position detection method - Identification signal amplitude Set an identification signal amplitude used in the minute position detection method. This parameter is enabled only when the magnetic pole detection is the minute position detection method. However, setting "0" will be 100% amplitude. | 0 [%] | 0 to 100 | Each | | | | | | | | | | | | | | | | | | | | | | | | | | | | | | | | | | | |

6. NORMAL GAIN ADJUSTMENT

6. NORMAL GAIN ADJUSTMENT

| POINT |
|---------------------------------------------------------------------------------------------------------------------------------------------------------------------------------------------------------------------------------------------------------------------------------------------------------------------------------------------------------------------------------------------------------------------------------------------------------------------------------------------------------------------------------------------------------------------------------------------------------------------------------------------------------------------------------------------------------------------------------------------------------------------------------------------------------------------------------------------------------------------------------------------------------------------------------------------------------------------------------------------------------------------------------------------------------------------------------------------------------------------------------------------|
| <ul style="list-style-type: none"> ● In the torque control mode, you do not need to make gain adjustment. ● Before making gain adjustment, check that your machine is not being operated at maximum torque of the servo motor. If operated over maximum torque, the machine may vibrate and may operate unexpectedly. In addition, make gain adjustment with a safety margin considering characteristic differences of each machine. It is recommended that generated torque during operation is under 90% of the maximum torque of the servo motor. ● When you use a linear servo motor, replace the following words in the left to the words in the right. <ul style="list-style-type: none"> Load to motor inertia ratio → Load to motor mass ratio Torque → Thrust (Servo motor) speed → (Linear servo motor) speed ● For the vibration suppression control tuning mode, the setting range of [Pr. PB07] is limited. For the vibration suppression control tuning mode, the setting range of [Pr. PB07] is limited. Refer to section 7.1.5 (4) for details. |

6.1 Different adjustment methods

6.1.1 Adjustment on a single servo amplifier

The following table shows the gain adjustment modes that can be set on a single servo amplifier. For gain adjustment, first execute "Auto tuning mode 1". If you are not satisfied with the result of the adjustment, execute "Auto tuning mode 2" and "Manual mode" in this order.

(1) Gain adjustment mode explanation

| Gain adjustment mode | [Pr. PA08] setting | Estimation of load to motor inertia ratio | Automatically set parameters | Manually set parameters |
|--------------------------------------------------|--------------------|-------------------------------------------|--------------------------------------------------------------------------------------------------|--------------------------------------------------------------------------------------------------|
| Auto tuning mode 1 (initial value) | --- 1 | Always estimated | GD2 ([Pr. PB06]) PG1 ([Pr. PB07]) PG2 ([Pr. PB08]) VG2 ([Pr. PB09]) VIC ([Pr. PB10]) | RSP ([Pr. PA09]) |
| Auto tuning mode 2 | --- 2 | Fixed to [Pr. PB06] value | PG1 ([Pr. PB07]) PG2 ([Pr. PB08]) VG2 ([Pr. PB09]) VIC ([Pr. PB10]) | GD2 ([Pr. PB06]) RSP ([Pr. PA09]) |
| Manual mode | --- 3 | | / | GD2 ([Pr. PB06]) PG1 ([Pr. PB07]) PG2 ([Pr. PB08]) VG2 ([Pr. PB09]) VIC ([Pr. PB10]) |
| 2 gain adjustment mode 1 (interpolation mode) | --- 0 | Always estimated | GD2 ([Pr. PB06]) PG2 ([Pr. PB08]) VG2 ([Pr. PB09]) VIC ([Pr. PB10]) | PG1 ([Pr. PB07]) RSP ([Pr. PA09]) |
| 2 gain adjustment mode 2 | --- 4 | Fixed to [Pr. PB06] value | PG2 ([Pr. PB08]) VG2 ([Pr. PB09]) VIC ([Pr. PB10]) | GD2 ([Pr. PB06]) PG1 ([Pr. PB07]) RSP ([Pr. PA09]) |

6. NORMAL GAIN ADJUSTMENT

(2) Adjustment sequence and mode usage

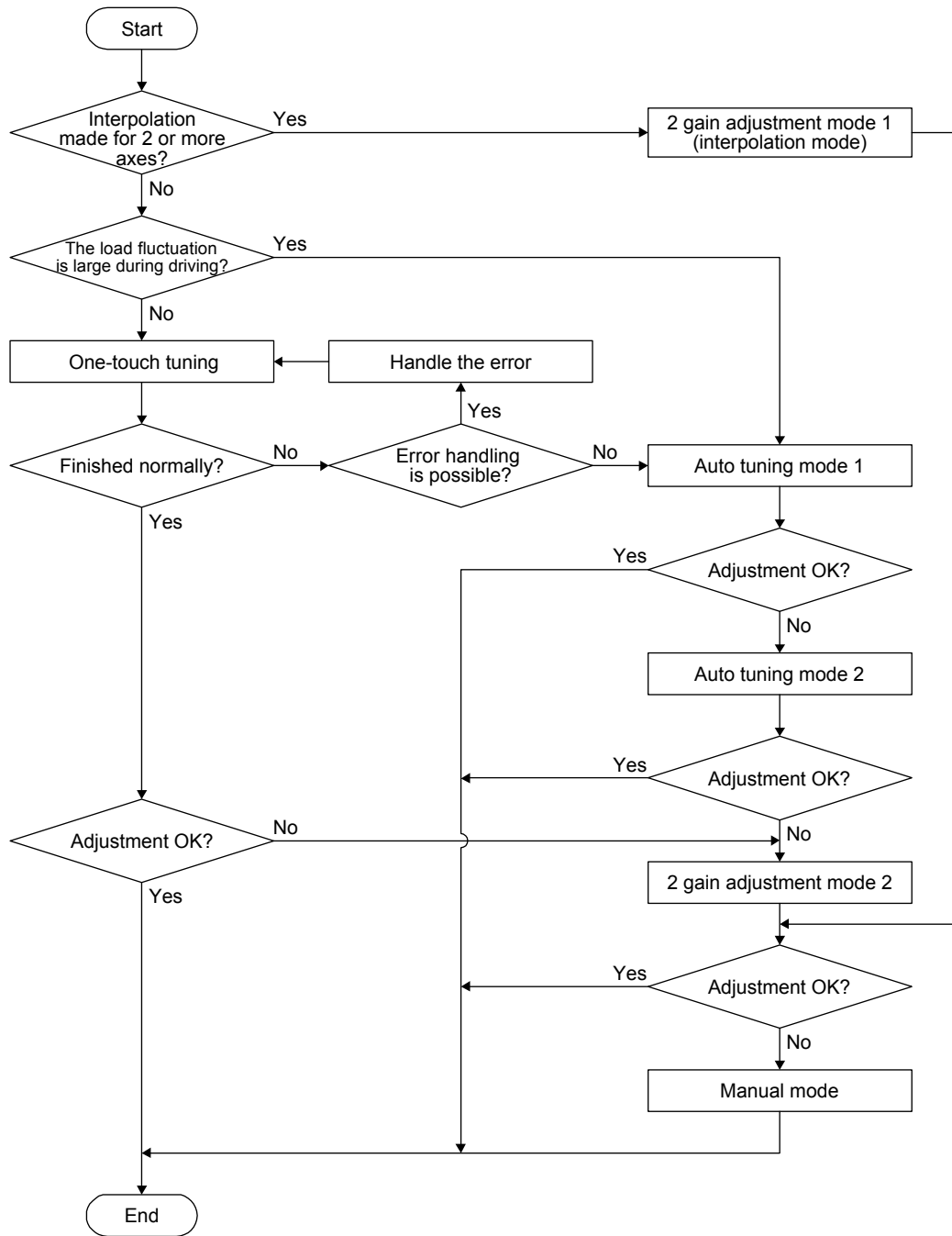

6.1.2 Adjustment using MR Configurator2

This section explains the functions and adjustment using the servo amplifier with MR Configurator2.

| Function | Description | Adjustment |
|------------------|----------------------------------------------------------------------------------------------------------------------------------------------------------------------------------------------------------------------|------------------------------------------------------------------------------------------------------------------------------|
| Machine analyzer | With the machine and servo motor coupled, the characteristic of the mechanical system can be measured by giving a random vibration command from a personal computer to the servo and measuring the machine response. | You can grasp the machine resonance frequency and determine the notch frequency of the machine resonance suppression filter. |

6. NORMAL GAIN ADJUSTMENT

6.2 One-touch tuning

| POINT |
|-----------------------------------------------------------------------------------------------------------------------------------------------------------------------------------------------------------------------------------------------------------------------------------------------------------------------------------------------------------------------------------------------------------------------------------------------------------------------------------------------------------------------------------------------------------------------------------------------------------------------------------------------------------------------------------------------------------------------------------------------------------------------------------------------------------------------------------------------------------------------------------------------------------------------------------------------------------------------------------------------------------------------------------------------------------------------------------------------------------------------------------------------------------------------------------------------------------------------------------------------------------------------------------------------------------------------------------------------------------------------------------------------------------------------------------------------------------------------------------------------------------------------------------------------------------------------------|
| <ul style="list-style-type: none"> ● After the one-touch tuning is completed, "Gain adjustment mode selection" in [Pr. PA08] will be set to "2 gain adjustment mode 2 (_ _ _ 4)". To estimate [Pr. PB06 Load to motor inertia ratio/load to motor mass ratio], set "Gain adjustment mode selection" in [Pr. PA08] to "Auto tuning mode 1 (_ _ _ 1)". ● When executing the one-touch tuning, check the [Pr. PA21 One-touch tuning function selection] is " _ _ _ 1" (initial value). ● At start of the one-touch tuning, only when "Auto tuning mode 1 (_ _ _ 1)" or "2 gain adjustment mode 1 (interpolation mode) (_ _ _ 0)" of "Gain adjustment mode selection" is selected in [Pr. PA08], [Pr. PB06 Load to motor inertia ratio/load to motor mass ratio] will be estimated. ● Execute the one-touch tuning while the servo system controller and the servo amplifier are connected. ● When executing the one-touch tuning in the test operation mode (SW2-1 is on), write the tuning result to servo parameters of the servo system controller, and then connect the servo system controller and the servo amplifier. ● The amplifier command method can be used with the servo amplifier with software version C1 or later and MR Configurator2 with software version 1.45X or later. ● When the one-touch tuning is executed, MR Configurator2 is required. ● For MR-J4W2-0303B6 servo amplifier, one-touch tuning by the amplifier command method will be available in the future. |

The one-touch tuning includes two methods: the user command method and the amplifier command method.

(1) User command method

The user command method performs one-touch tuning by inputting commands from outside the servo amplifier.

(2) Amplifier command method

In the amplifier command method, when you simply input a travel distance (permissible travel distance) that collision against the equipment does not occur during servo motor driving, a command for the optimum tuning will be generated inside the servo amplifier to perform one-touch tuning.

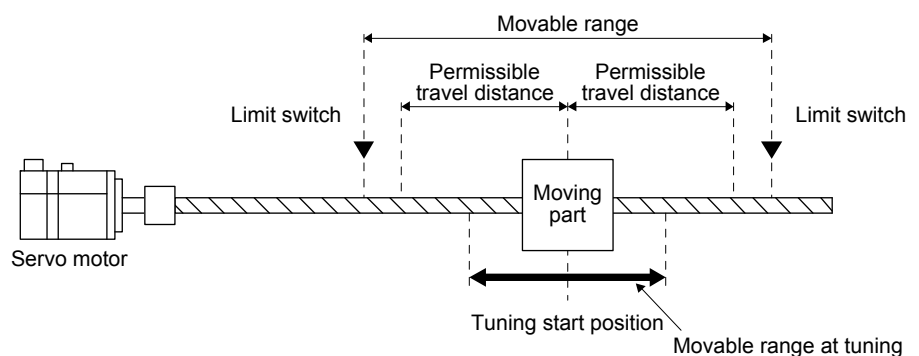

6. NORMAL GAIN ADJUSTMENT

The following parameters are set automatically with one-touch tuning. Also, "Gain adjustment mode selection" in [Pr. PA08] will be "2 gain adjustment mode 2 (_ _ _ 4)" automatically. Other parameters will be set to an optimum value depending on the setting of [Pr. PA09 Auto tuning response].

Table 6.1 List of parameters automatically set with one-touch tuning

| Parameter | Symbol | Name |
|-----------|--------|---------------------------------------------------------------------------------------|
| PA08 | ATU | Auto tuning mode |
| PA09 | RSP | Auto tuning response |
| PB01 | FILT | Adaptive tuning mode (adaptive filter II) |
| PB02 | VRFT | Vibration suppression control tuning mode (advanced vibration suppression control II) |
| PB06 | GD2 | Load to motor inertia ratio |
| PB07 | PG1 | Model loop gain |
| PB08 | PG2 | Position loop gain |
| PB09 | VG2 | Speed loop gain |
| PB10 | VIC | Speed integral compensation |
| PB12 | OVA | Overshoot amount compensation |
| PB13 | NH1 | Machine resonance suppression filter 1 |
| PB14 | NHQ1 | Notch shape selection 1 |
| PB15 | NH2 | Machine resonance suppression filter 2 |
| PB16 | NHQ2 | Notch shape selection 2 |
| PB17 | NHF | Shaft resonance suppression filter |

| Parameter | Symbol | Name |
|-----------|--------|---------------------------------------------------------------|
| PB18 | LPF | Low-pass filter setting |
| PB19 | VRF11 | Vibration suppression control 1 - Vibration frequency |
| PB20 | VRF12 | Vibration suppression control 1 - Resonance frequency |
| PB21 | VRF13 | Vibration suppression control 1 - Vibration frequency damping |
| PB22 | VRF14 | Vibration suppression control 1 - Resonance frequency damping |
| PB23 | VFBF | Low-pass filter selection |
| PB46 | NH3 | Machine resonance suppression filter 3 |
| PB47 | NHQ3 | Notch shape selection 3 |
| PB48 | NH4 | Machine resonance suppression filter 4 |
| PB49 | NHQ4 | Notch shape selection 4 |
| PB51 | NHQ5 | Notch shape selection 5 |
| PE41 | EOP3 | Function selection E-3 |

6. NORMAL GAIN ADJUSTMENT

6.2.1 One-touch tuning flowchart

(1) User command method

Make one-touch tuning as follows.

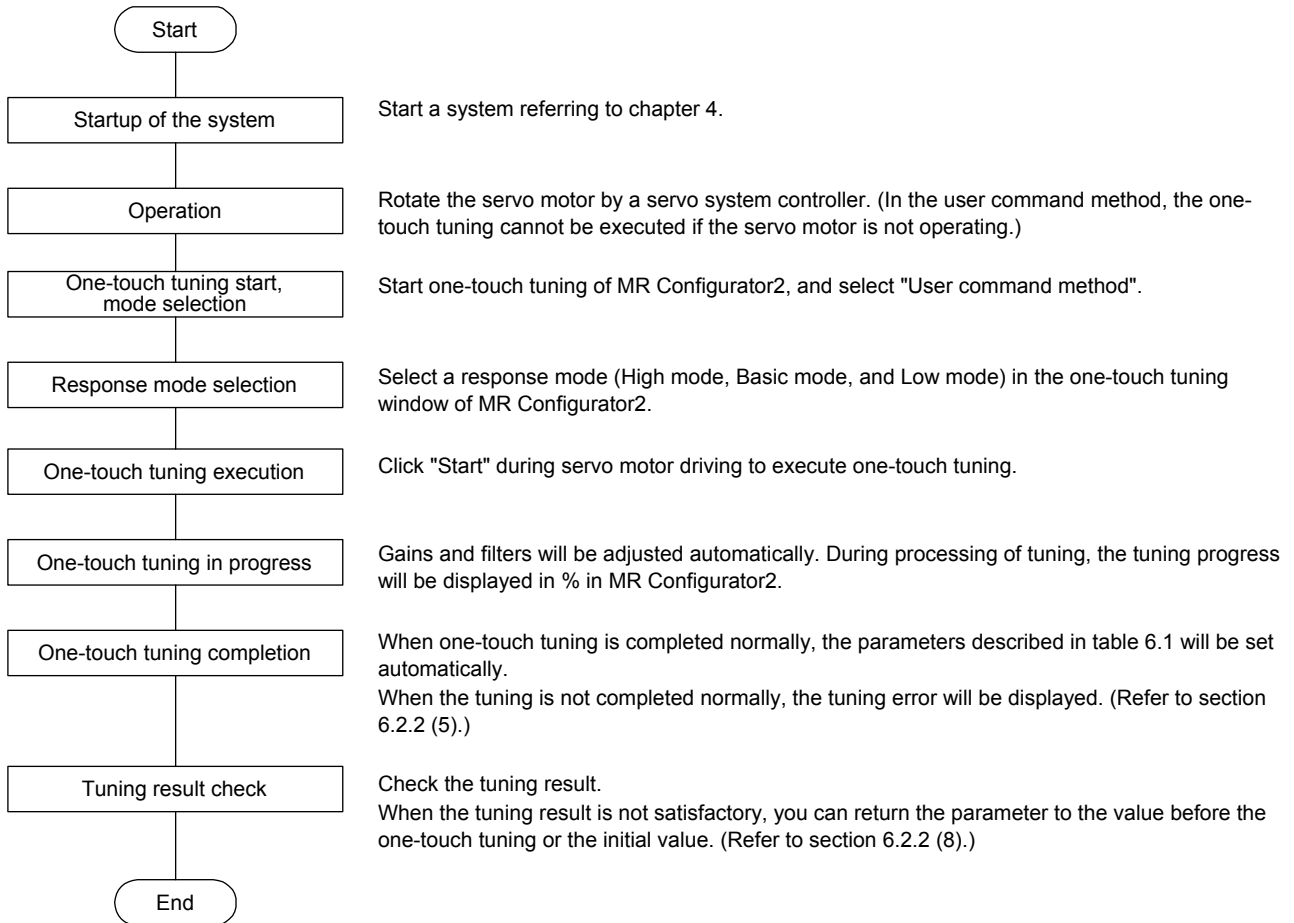

6. NORMAL GAIN ADJUSTMENT

(2) Amplifier command method

Make one-touch tuning as follows.

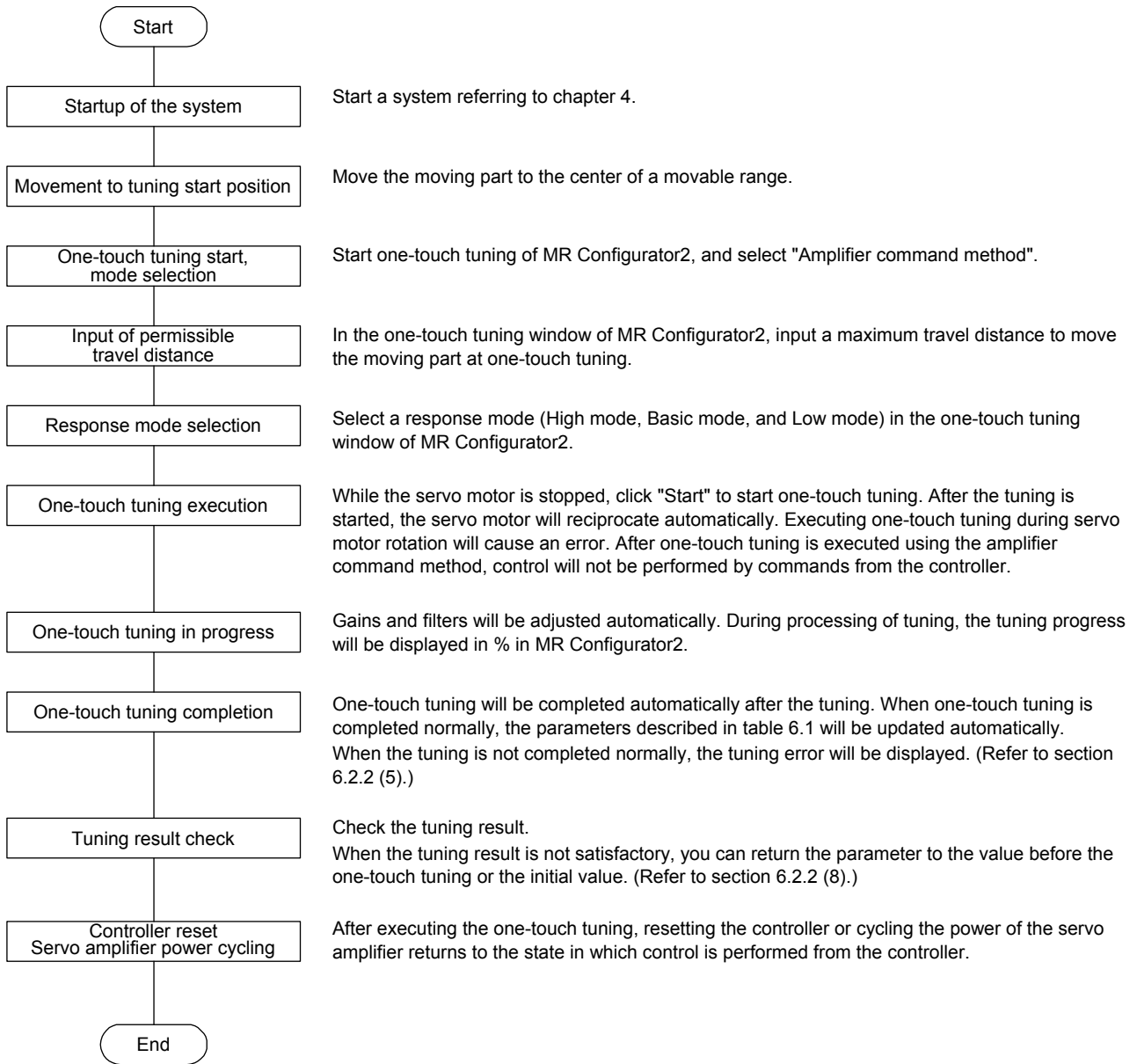

6. NORMAL GAIN ADJUSTMENT

6.2.2 Display transition and operation procedure of one-touch tuning

(1) Command method selection

Select a command method from two methods in the one-touch tuning window of MR Configurator2.

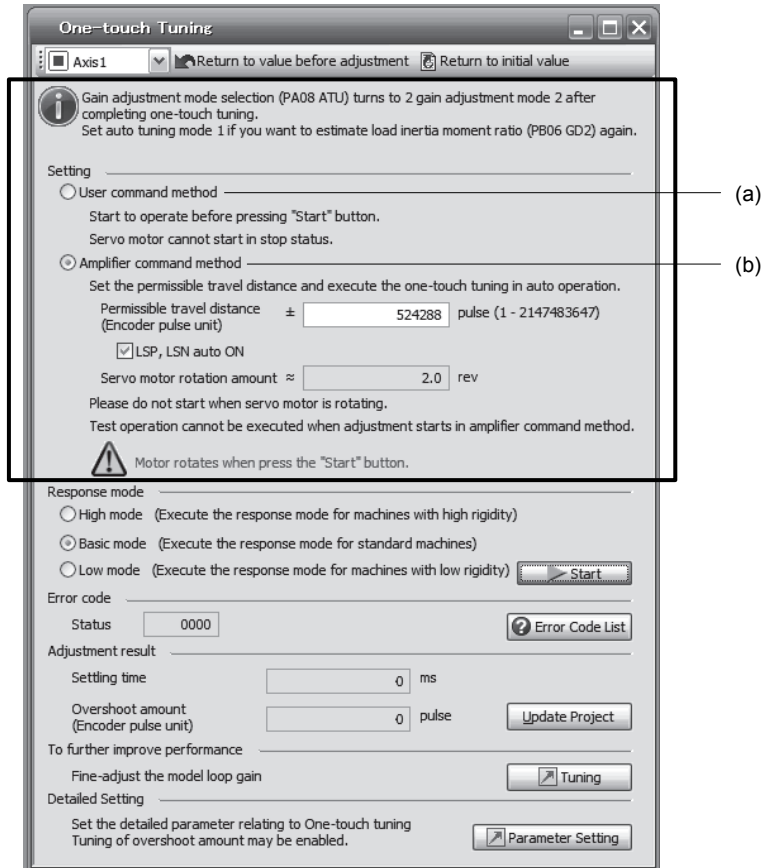

6. NORMAL GAIN ADJUSTMENT

(a) User command method

It is recommended to input commands meeting the following conditions to the servo amplifier. If one-touch tuning is executed while commands which do not meet the conditions are inputted to the servo amplifier, the one-touch tuning error may occur.

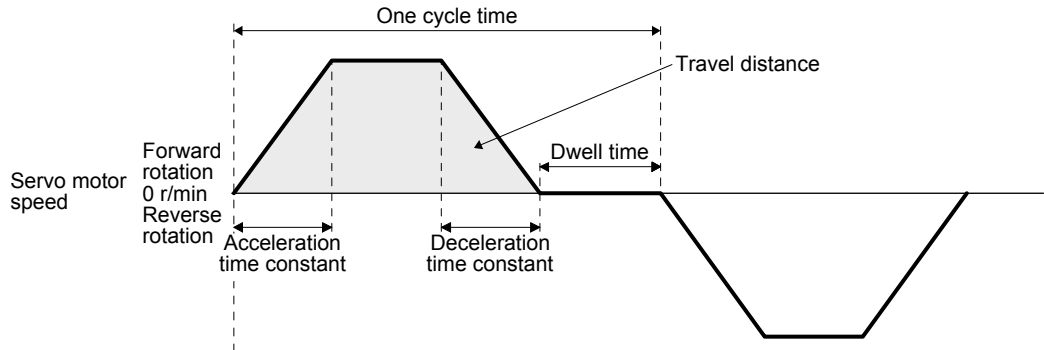

Fig. 6.1 Recommended command for one-touch tuning in the user command method

| Item | Description |
|----------------------------------------------------------|-----------------------------------------------------------------------------------------------------------------------------------------------------------------------------------------------------------------------------------------------------------------------------------------------------------------------------------------------------------------------------------------------------------------|
| Travel distance | Set 100 pulses or more in encoder unit. Setting less than 100 pulses will cause the one-touch tuning error "C004". |
| Servo motor speed | Set 150 r/min (mm/s) or higher. Setting less than 150 r/min (mm/s) may cause the one-touch tuning error "C005". |
| Acceleration time constant Deceleration time constant | Set the time to reach 2000 r/min (mm/s) to 5 s or less. Set an acceleration time constant/deceleration time constant so that the acceleration/deceleration torque is 10% or more of the rated torque. The estimation accuracy of the load to motor inertia ratio is more improved as the acceleration/deceleration torque is larger, and the one-touch tuning result will be closer to the optimum value. |
| Dwell time | Set 200 ms or more. Setting a smaller value may cause the one-touch tuning error "C004". |
| One cycle time | Set 30 s or less. Setting over 30 s will cause the one-touch tuning error "C004". |

6. NORMAL GAIN ADJUSTMENT

(b) Amplifier command method

Input a permissible travel distance. Input it in the load-side resolution unit for the fully closed loop control mode, and in the servo motor-side resolution unit for other control modes. In the amplifier command method, the servo motor will be operated in a range between "current value \pm permissible travel distance". Input the permissible travel distance as large as possible within a range that the movable part does not collide against the machine. Inputting a small permissible travel distance decreases the possibility that the moving part will collide against the machine. However, the estimation accuracy of the load to motor inertia ratio may be lower, resulting in improper tuning. Also, executing the one-touch tuning in the amplifier command method will generate a command for the following optimum tuning inside the servo amplifier to start the tuning.

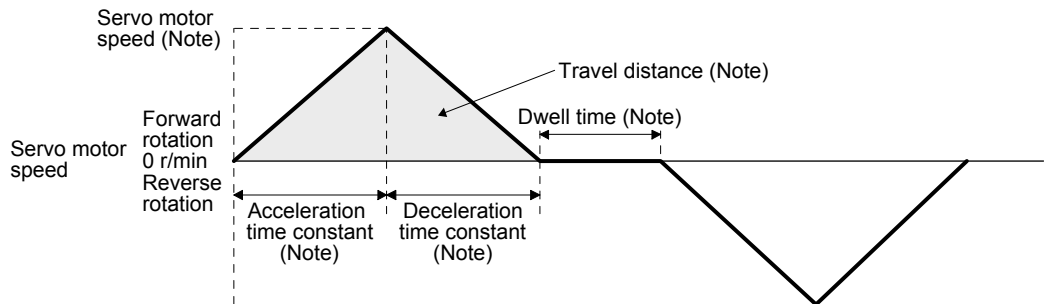

Note. It will be automatically generated in the servo amplifier.

Fig. 6.2 Command generated by one-touch tuning in the amplifier command method

| Item | Description |
|----------------------------------------------------------|---------------------------------------------------------------------------------------------------------------------------------------------------------------------------------------------------------------------------------|
| Travel distance | An optimum travel distance will be automatically set in the range not exceeding the user-inputted permissible travel distance with MR Configurator2. |
| Servo motor speed | A speed not exceeding 1/2 of the rated speed and overspeed alarm detection level ([Pr. PC08]) will be automatically set. |
| Acceleration time constant Deceleration time constant | An acceleration time constant/deceleration time constant will be automatically set so as not to exceed 60% of the rated torque and the torque limit value set at the start of one-touch tuning in the amplifier command method. |
| Dwell time | A dwell time in which the one-touch tuning error "C004" does not occur will be automatically set. |

6. NORMAL GAIN ADJUSTMENT

(2) Response mode selection

Select a response mode from 3 modes in the one-touch tuning window of MR Configurator2.

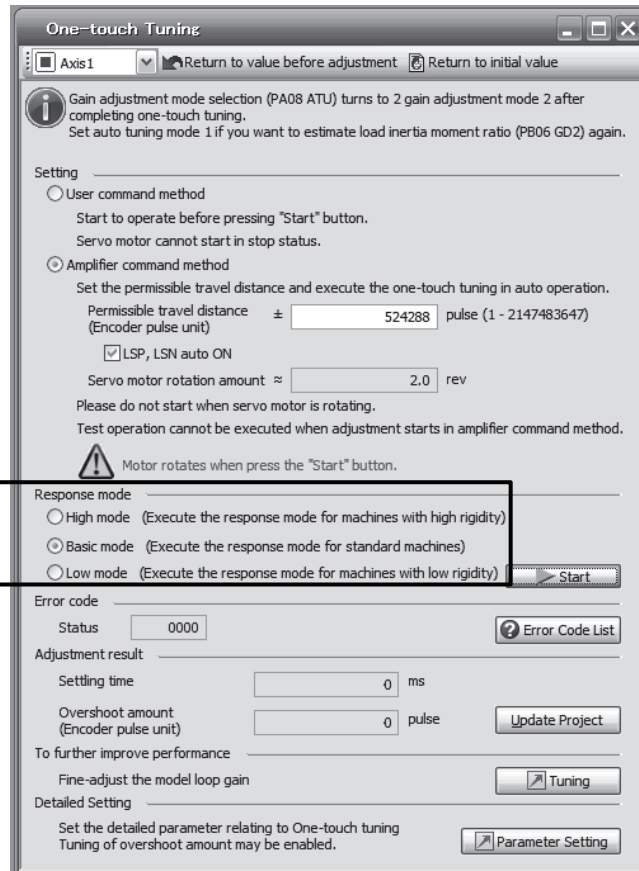

Table 6.2 Response mode explanations

| Response mode | Explanation |
|---------------|-------------------------------------|
| High mode | This mode is for high-rigid system. |
| Basic mode | This mode is for standard system. |
| Low mode | This mode is for low-rigid system. |

6. NORMAL GAIN ADJUSTMENT

Refer to the following table for selecting a response mode.

Table 6.3 Guideline for response mode

| Response mode | | | Response | Machine characteristic |
|---------------|------------|-----------|-----------------------------------------|------------------------------------|
| Low mode | Basic mode | High mode | | Guideline of corresponding machine |
| ↑ ↓ | ↑ ↓ | ↑ ↓ | Low response ↑ ↓ High response | |

(3) One-touch tuning execution

| POINT |
|-----------------------------------------------------------------------------------------------------------------------------------------------------------------------------------------------------------------------------------------------------------------------------------------------------------------------------------------------------------------------------------------------------------------------------------------------------------------------------------------------------------------------------------------------------------------------------------------------------------------------------------------------------------------------------------------------------------------------------------------------------------------------------------------------------------------------------------------------------------------------------------------------------------------------------------------------------------------------------------------------------------------------------------------------------------------------------------------------------------------------------------------------------------------------------------|
| <ul style="list-style-type: none"> ● For equipment in which overshoot during one-touch tuning is in the permissible level of the in-position range, changing the value of [Pr. PA25 One-touch tuning overshoot permissible level] will shorten the settling time and improve the response. ● When executing one-touch tuning in the amplifier command method, turn on EM2. When you turn off EM2 during one-touch tuning, "C008" will be displayed at status in error code, and the one-touch tuning will be canceled. ● When executing the one-touch tuning in the amplifier command method, FLS (Upper stroke limit) and RLS (Lower stroke limit) will be disabled. Thus, set a permissible travel distance within a range where moving part collision never occurs, or execute the one-touch tuning in a state in which the servo motor can immediately stop in emergency. ● When one-touch tuning is executed in the amplifier command method while magnetic pole detection is not being performed, magnetic pole detection will be performed, and then one-touch tuning will start after the magnetic pole detection is completed. |

After the response mode is selected in (2) in this section, clicking "Start" will start one-touch tuning. If "Start" is clicked while the servo motor stops, "C002" or "C004" will be displayed at status in error code. (Refer to (5) in this section for error codes.)

6. NORMAL GAIN ADJUSTMENT

Click "Start" with the amplifier command method selected in the servo-off, the servo-on will be automatically enabled, and the one-touch tuning will start. In the one-touch tuning by the amplifier command method, an optimum tuning command will be generated in the servo amplifier after servo-on. Then, the servo motor will reciprocate, and the one-touch tuning will be executed. After the tuning is completed or canceled, the servo amplifier will be the servo-off status. When the servo-on command is inputted from outside, the amplifier will be the servo-on status.

After one-touch tuning is executed using the amplifier command method, control will not be performed by commands from the controller. To return to the state in which control is performed by commands from the controller, reset the controller or cycle the power.

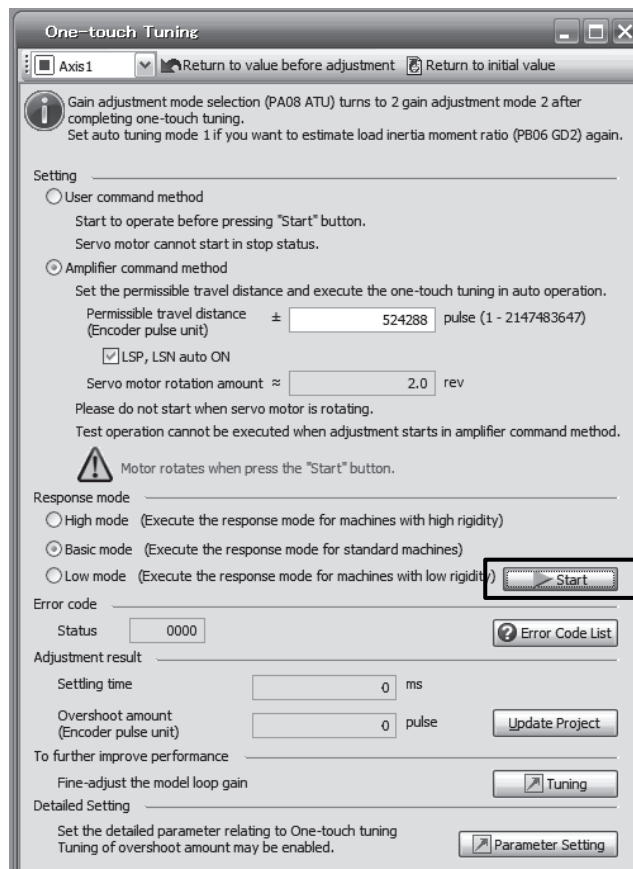

During processing of one-touch tuning, the progress will be displayed as follows. Tuning will be completed at 100%.

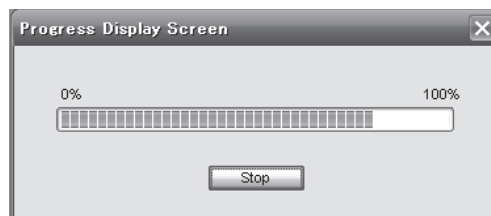

6. NORMAL GAIN ADJUSTMENT

Completing the one-touch tuning will start writing tuning parameters to the servo amplifier, and the following window will be displayed. Select whether or not to reflect the tuning result in the project.

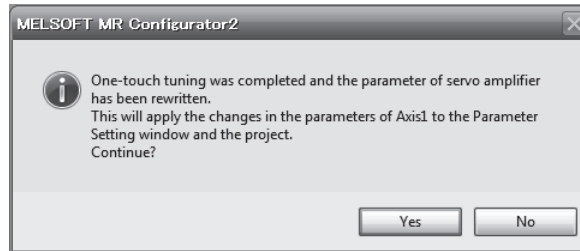

After the one-touch tuning is completed, "0000" will be displayed at status in error code. In addition, settling time and overshoot amount will be displayed in "Adjustment result".

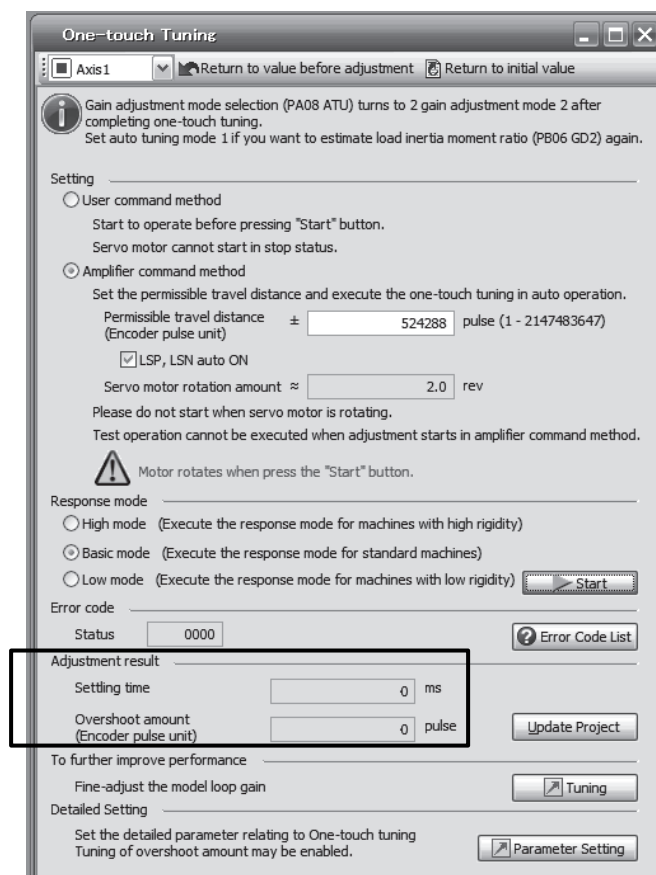

(4) Stop of one-touch tuning

When "Stop" is clicked during one-touch tuning, the tuning will be stopped. At this time, "C000" will be displayed at status in error code. When the one-touch tuning is stopped, the parameter setting will be returned to the values at the start of the one-touch tuning. Stop the servo motor before executing the one-touch tuning again. In addition, execute it after the moving part is returned to the tuning start position.

6. NORMAL GAIN ADJUSTMENT

(5) If an error occurs

If a tuning error occurs during tuning, one-touch tuning will be stopped. With that, the following error code will be displayed in status. Check the cause of tuning error. When executing one-touch tuning again, stop the servo motor once. In addition, after returning the moving part to the tuning start position, execute it.

| Display | Name | Error detail | Corrective action example |
|---------|------------------------------------------|------------------------------------------------------------------------------------------------------------------------------------------------------------------------------------------------------------------------------------------|-----------------------------------------------------------------------------------------------------------------------------------------------------------------------------------------------------------------------------------------------------------------------------------------------------------------------------------------------------------------------------------------------------------------------------------------------------------------------------------------------------------------------------------------------------------------------------------------------------------------------------------------------------------------------------------------------------------------------------------------------------------------------------------------------------------------------------------------------------------------------------------------------------------------------------------------------------------|
| C000 | Tuning canceled | "Stop" was clicked during one-touch tuning. | |
| C001 | Overshoot exceeded | Overshoot amount is a value larger than the one set in [Pr. PA10 In-position range] and [Pr. PA25 One-touch tuning - Overshoot permissible level]. | Increase the in-position range or overshoot permissible level. |
| C002 | Servo-off during tuning | The one-touch tuning was attempted in the user command method during servo-off. The servo amplifier will be servo-off status during one-touch tuning. | When executing one-touch tuning in the user command method, turn to servo-on, and then execute it. Prevent the servo amplifier from being the servo-off status during one-touch tuning. |
| C003 | Control mode error | 1. The one-touch tuning was attempted while the torque control mode was selected in the control modes. 2. During one-touch tuning, the control mode was attempted to change from the position control mode to the speed control mode. | Select the position control mode or speed control mode for the control mode from the controller, and then execute one-touch tuning. Do not change the control mode during the one-touch tuning. |
| C004 | Time-out | 1. One cycle time during the operation has been over 30 s. 2. The command speed is slow. 3. The operation interval of the continuous operation is short. | Set one cycle time during the operation (time from the command start to the next command start) to 30 s or less. Set the servo motor speed to 100 r/min or higher. Error is less likely to occur as the setting speed is higher. When one-touch tuning by the amplifier command is used, set a permissible travel distance so that the servo motor speed is 100 r/min or higher. Set a permissible travel distance to two or more revolutions as a guide value to set the servo motor speed to 100 r/min. Set the stop interval during operation to 200 ms or more. Error is less likely to occur as the setting time is longer. |
| C005 | Load to motor inertia ratio misestimated | 1. The estimation of the load to motor inertia ratio at one-touch tuning was a failure. 2. The load to motor inertia ratio was not estimated due to an oscillation or other influences. | Drive the motor with meeting conditions as follows. <ul style="list-style-type: none"> • The acceleration time constant/deceleration time constant to reach 2000 r/min (mm/s) is 5 s or less. • Speed is 150 r/min (mm/s) or higher. • The load to servo motor (mass of linear servo motor's primary side or direct drive motor) inertia ratio is 100 times or less. • The acceleration/deceleration torque is 10% or more of the rated torque. Set to the auto tuning mode that does not estimate the load to motor inertia ratio as follows, and then execute the one-touch tuning. <ul style="list-style-type: none"> • Select "Auto tuning mode 2 (_ _ _ 2)", "Manual mode (_ _ _ 3)", or "2 gain adjustment mode 2 (_ _ _ 4)" of "Gain adjustment mode selection" in [Pr. PA08]. • Manually set [Pr. PB06 Load to motor inertia ratio/load to motor mass ratio] properly. |

6. NORMAL GAIN ADJUSTMENT

| Display | Name | Error detail | Corrective action example |
|---------|------------------------------------|---------------------------------------------------------------------------------------------------------------------------------------------------------------------------------------------------------------------------------------------------------------------------------------------------------------------------------------------------|-------------------------------------------------------------------------------------------------------------------------------------------------------------------------------------------------------------------------------------------------------------------------------------------------------------------------------------------------------------------------------------------------------------------------------------------------------------------------------------------------------------------------------------------------------------------------------------------------------------------------------------------------------------------------------------------------------------------------------------------------------------------------------------------------------------------------------------------------------------------|
| C006 | Amplifier command start error | One-touch tuning was attempted to start in the amplifier command method under the following speed condition. Servo motor speed of one axis.: 20 r/min or higher | Execute the one-touch tuning in the amplifier command method while the servo motor is stopped. |
| C007 | Amplifier command generation error | 1. One-touch tuning was executed in the amplifier command method when the permissible travel distance is set to 100 pulses or less in the encoder pulse unit, or the distance is set not to increase the servo motor speed to 150 r/min (mm/s) (50 r/min for direct drive motor) or higher at the time of load to motor inertia ratio estimation. | Set a permissible travel distance to 100 pulses or more in the encoder pulse unit, or a distance so as to increase the servo motor speed to 150 r/min (mm/s) (50 r/min for direct drive motor) or higher at the time of load to motor inertia ratio estimation, and then execute the one-touch tuning. Set a permissible travel distance to four or more revolutions as a guide value. Load to motor inertia ratio will be estimated when "0000" or "0001" is set in [Pr. PA08 Auto tuning mode] at the start of one-touch tuning. If the permissible travel distance is short and the servo motor speed cannot be increased to 150 r/min (mm/s) (50 r/min for direct drive motor) or higher, select "Auto tuning mode 2 (_ _ _ 2)", "Manual mode (_ _ _ 3)", or "2 gain adjustment mode 2 (_ _ _ 4)" of "Gain adjustment mode selection" in [Pr. PA08]. |
| | | 2. An overspeed alarm detection level is set so that the servo motor speed becomes 150 r/min (mm/s) (50 r/min for direct drive motor) or less at the time of load to motor inertia ratio estimation. | When estimating the load to motor inertia ratio, set the overspeed alarm detection level so that the speed becomes 150 r/min or more. |
| | | 3. The torque limit has been set to 0. | Set the torque limit value to greater than 0. |
| C008 | Stop signal | EM2 was turned off during one-touch tuning in the amplifier command method. | Review the one-touch tuning start position and permissible travel distance for the amplifier command method. After ensuring safety, turn on EM2. |
| C009 | Parameter | Parameters for manufacturer setting have been changed. | Return the parameters for manufacturer setting to the initial values. |
| C00A | Alarm | One-touch tuning was attempted to start in the amplifier command method during alarm or warning. Alarm or warning occurred during one-touch tuning by the amplifier command method. | Start one-touch tuning when no alarm or warning occurs. Prevent alarm or warning from occurring during one-touch tuning. |
| C00F | One-touch tuning disabled | "One-touch tuning function selection" in [Pr. PA21] is "Disabled (_ _ _ 0)". | Select "Enabled (_ _ _ 1)". |

(6) If an alarm occurs

If an alarm occurs during the one-touch tuning, the tuning will be forcibly terminated. Remove the cause of the alarm and execute one-touch tuning again. When executing one-touch tuning in the amplifier command method again, return the moving part to the tuning start position.

(7) If a warning occurs

If a warning which continues the motor driving occurs during one-touch tuning by the user command method, the tuning will be continued. If a warning which does not continue the motor driving occurs during the tuning, one-touch tuning will be stopped.

One-touch tuning will be stopped when warning occurs during one-touch tuning by the amplifier command method regardless of the warning type. Remove the cause of the warning, and return the moving part to the tuning start position. Then, execute the tuning again.

6. NORMAL GAIN ADJUSTMENT

(8) Initializing one-touch tuning

Clicking "Return to initial value" in the one-touch tuning window of MR Configurator2 enables to return the parameter to the initial value. Refer to table 6.1 for the parameters which you can initialize.

Clicking "Return to value before adjustment" in the one-touch tuning window of MR Configurator2 enables to return the parameter to the value before clicking "Start".

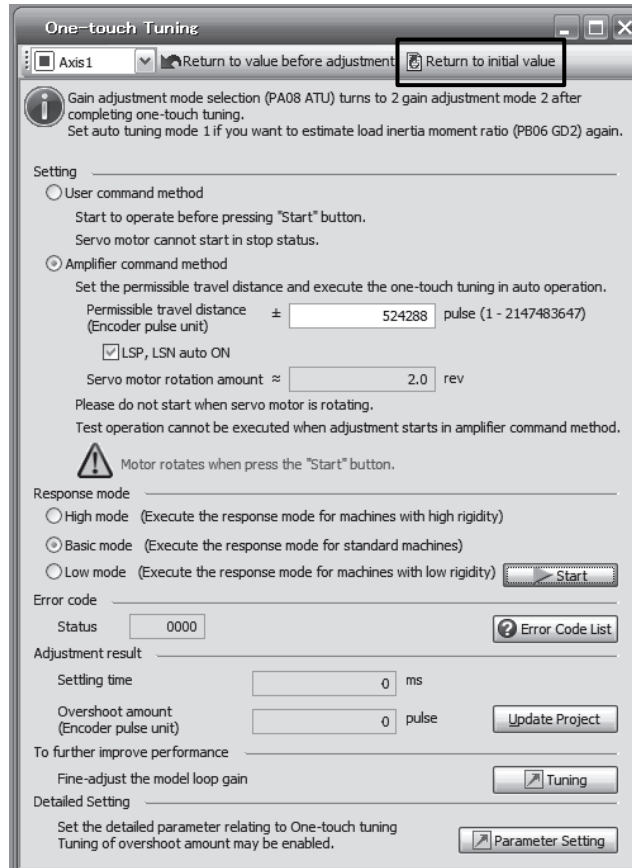

When the initialization of one-touch tuning is completed, the following window will be displayed. (returning to initial value)



6. NORMAL GAIN ADJUSTMENT

6.2.3 Caution for one-touch tuning

- (1) Caution common for user command method and amplifier command method
 - (a) The tuning is not available in the torque control mode.
 - (b) The one-touch tuning cannot be executed while an alarm or warning which does not continue the motor driving is occurring.
 - (c) The one-touch tuning cannot be executed during the following test operation mode.
 - 1) Output signal (DO) forced output
 - 2) Motor-less operation
 - (d) If one-touch tuning is performed when the gain switching function is enabled, vibration and/or unusual noise may occur during the tuning.
- (2) Caution for amplifier command method
 - (a) Starting one-touch tuning while the servo motor is rotating displays "C006" at status in error code, and the one-touch tuning cannot be executed.
 - (b) Start one-touch tuning when all connected servo motors are at a stop.
 - (c) One-touch tuning is not available during the test operation mode. The following test operation modes cannot be executed during one-touch tuning.
 - 1) Positioning operation
 - 2) JOG operation
 - 3) Program operation
 - 4) Machine analyzer operation
 - (d) After one-touch tuning is executed, control will not be performed by commands from the servo system controller. To return to the state in which control is performed from the servo system controller, reset the controller or cycle the power of the servo amplifier.
 - (e) During one-touch tuning, the permissible travel distance may be exceeded due to overshoot, set a value sufficient to prevent machine collision.
 - (f) When Auto tuning mode 2, Manual mode, or 2 gain adjustment mode 2 is selected in [Pr. PA08 Auto tuning mode], the load to motor inertia ratio will not be estimated. An optimum acceleration/deceleration command will be generated by [Pr. PB06 Load to motor inertia ratio/load to motor mass ratio] at the start of one-touch tuning. When the load to motor inertia ratio is incorrect, the optimum acceleration/deceleration command may not be generated, causing the tuning to fail.
 - (g) When one-touch tuning is started by using USB communication, if the USB communication is interrupted during the tuning, the servo motor will stop, and the tuning will also stop. The parameter will return to the one at the start of the one-touch tuning.
 - (h) When one-touch tuning is started via the controller, if communication between the controller and the servo amplifier or personal computer is shut-off during the tuning, the servo motor will stop, and the tuning will also stop. The parameter will return to the one at the start of the one-touch tuning.
 - (i) When one-touch tuning is started during the speed control mode, the mode will be switched to the position control mode automatically. The tuning result may differ from the one obtained by executing tuning by using the speed command.

6. NORMAL GAIN ADJUSTMENT

6.3 Auto tuning

6.3.1 Auto tuning mode

The servo amplifier has a real-time auto tuning function which estimates the machine characteristic (load to motor inertia ratio) in real time and automatically sets the optimum gains according to that value. This function permits ease of gain adjustment of the servo amplifier.

(1) Auto tuning mode 1

The servo amplifier is factory-set to the auto tuning mode 1.

In this mode, the load to motor inertia ratio of a machine is always estimated to set the optimum gains automatically.

The following parameters are automatically adjusted in the auto tuning mode 1.

| Parameter | Symbol | Name |
|-----------|--------|------------------------------------------------------|
| PB06 | GD2 | Load to motor inertia ratio/load to motor mass ratio |
| PB07 | PG1 | Model loop gain |
| PB08 | PG2 | Position loop gain |
| PB09 | VG2 | Speed loop gain |
| PB10 | VIC | Speed integral compensation |

| POINT |
|-----------------------------------------------------------------------------------------------------------------------------------------------------------------------------------------------------------------------------------------------------------------------------------------------------------------------------------------------------------------------------------------------------------------------------------------------------------------------------------------------------------------------------------------------------------------------------------------------------------------------------------------------------------------------------------------------------------------------------------------------------------------------------------------------------------------------------------------------------------------------------------------|
| <ul style="list-style-type: none">● The auto tuning mode 1 may not be performed properly if all of the following conditions are not satisfied.<ul style="list-style-type: none">▪ The time until the acceleration/deceleration time constant reach 2000 r/min (mm/s) is 5 s or less.▪ Speed is 150 r/min (mm/s) or higher.▪ The load to servo motor (mass of linear servo motor's primary side or direct drive motor) inertia ratio is 100 times or less.▪ The acceleration/deceleration torque is 10% or more of the rated torque.● Under operating conditions which will impose sudden disturbance torque during acceleration/deceleration or on a machine which is extremely loose, auto tuning may not function properly, either. In such cases, use the auto tuning mode 2 or manual mode to make gain adjustment. |

(2) Auto tuning mode 2

Use the auto tuning mode 2 when proper gain adjustment cannot be made by auto tuning mode 1. Since the load to motor inertia ratio is not estimated in this mode, set the value of a correct load to motor inertia ratio in [Pr. PB06].

The following parameters are automatically adjusted in the auto tuning mode 2.

| Parameter | Symbol | Name |
|-----------|--------|-----------------------------|
| PB07 | PG1 | Model loop gain |
| PB08 | PG2 | Position loop gain |
| PB09 | VG2 | Speed loop gain |
| PB10 | VIC | Speed integral compensation |

6. NORMAL GAIN ADJUSTMENT

6.3.2 Auto tuning mode basis

The block diagram of real-time auto tuning is shown below.

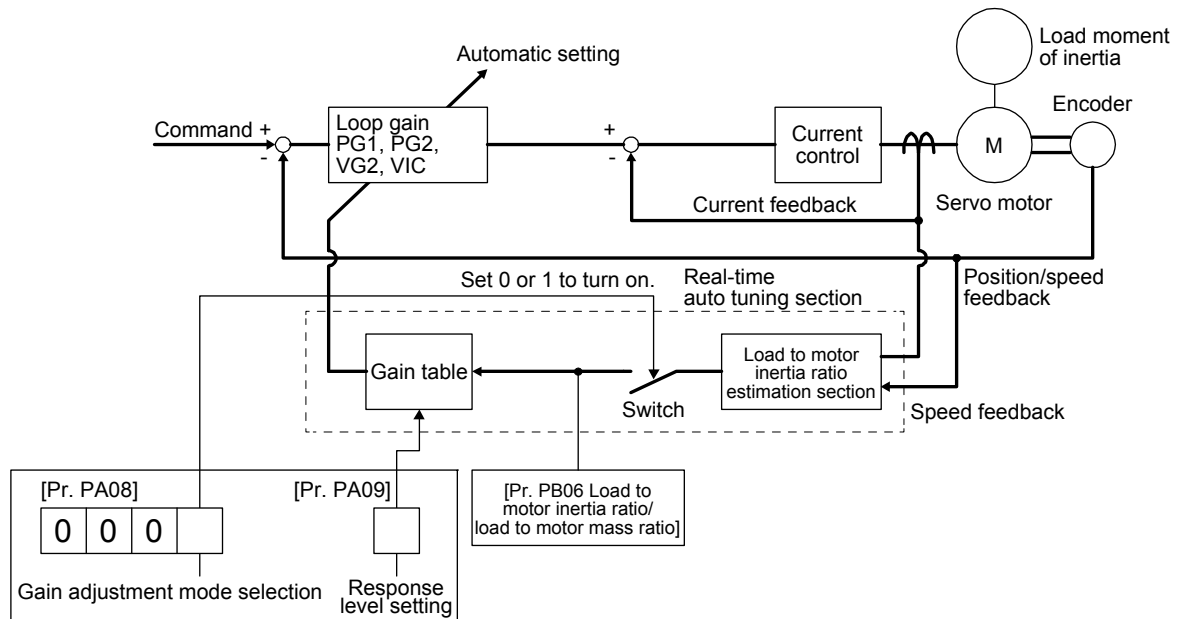

When a servo motor is accelerated/decelerated, the load to motor inertia ratio estimation section always estimates the load to motor inertia ratio from the current and speed of the servo motor. The results of estimation are written to [Pr. PB06 Load to motor inertia ratio/load to motor mass ratio]. These results can be confirmed on the status display screen of the MR Configurator2.

If you have already known the value of the load to motor inertia ratio or failed to estimate, set "Gain adjustment mode selection" to "Auto tuning mode 2 (_ _ _ 2)" in [Pr. PA08] to stop the estimation (turning off the switch in above diagram), and set the load to motor inertia ratio or load to motor mass ratio ([Pr. PB06]) manually.

From the preset load to motor inertia ratio ([Pr. PB06]) value and response ([Pr. PA09]), the optimum loop gains are automatically set on the basis of the internal gain table.

The auto tuning results are saved in the EEPROM of the servo amplifier every 60 minutes since power-on. At power-on, auto tuning is performed with the value of each loop gain saved in the EEPROM being used as an initial value.

| POINT |
|--------------------------------------------------------------------------------------------------------------------------------------------------------------------------------------------------------------------------------------------------------------------------------------------------------------------------------------------------------------------------------------------------------------------------------------------------------------------------------------------------------------------------------------------------------------------------------|
| <ul style="list-style-type: none"> ● If sudden disturbance torque is imposed during operation, the load to motor inertia ratio may be misestimated temporarily. In such a case, set "Gain adjustment mode selection" to "Auto tuning mode 2 (_ _ _ 2)" in [Pr. PA08] and then set the correct load to motor inertia ratio in [Pr. PB06]. ● When any of the auto tuning mode 1 and auto tuning mode settings is changed to the manual mode 2 setting, the current loop gains and load to motor inertia ratio estimation value are saved in the EEPROM. |

6. NORMAL GAIN ADJUSTMENT

6.3.3 Adjustment procedure by auto tuning

Since auto tuning is enabled before shipment from the factory, simply running the servo motor automatically sets the optimum gains that match the machine. Merely changing the response level setting value as required completes the adjustment. The adjustment procedure is as follows.

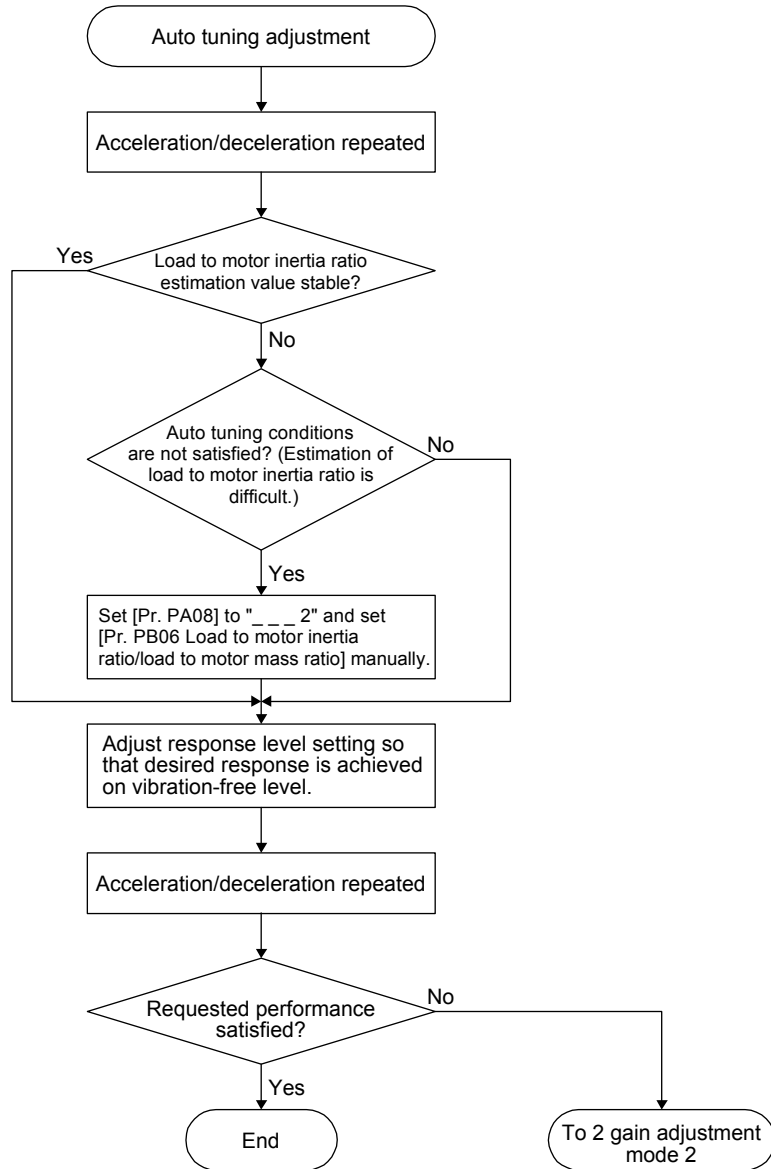

6. NORMAL GAIN ADJUSTMENT

6.3.4 Response level setting in auto tuning mode

Set the response of the whole servo system by [Pr. PA09]. As the response level setting is increased, the trackability to a command improves and settling time decreases, but setting the response level too high will generate vibration. Set a value to obtain the desired response level within the vibration-free range.

If the response level setting cannot be increased up to the desired response because of machine resonance beyond 100 Hz, filter tuning mode selection in [Pr. PB01] or machine resonance suppression filter in [Pr. PB13] to [Pr. PB16], [Pr. PB46] to [Pr. PB51] may be used to suppress machine resonance. Suppressing machine resonance may allow the response level setting to increase. Refer to section 7.2 and 7.3 for settings of the adaptive tuning mode and machine resonance suppression filter.

[Pr. PA09]

| Setting value | Machine characteristic | | Reference (setting value of MR-J3 and MR-J3W) |
|---------------|------------------------|------------------------------------------------|-----------------------------------------------|
| | Response | Guideline for machine resonance frequency [Hz] | |
| 1 | Low response | 2.7 | |
| 2 | | 3.6 | |
| 3 | | 4.9 | |
| 4 | | 6.6 | |
| 5 | | 10.0 | 1 |
| 6 | | 11.3 | 2 |
| 7 | | 12.7 | 3 |
| 8 | | 14.3 | 4 |
| 9 | | 16.1 | 5 |
| 10 | | 18.1 | 6 |
| 11 | 20.4 | 7 | |
| 12 | 23.0 | 8 | |
| 13 | 25.9 | 9 | |
| 14 | 29.2 | 10 | |
| 15 | 32.9 | 11 | |
| 16 | 37.0 | 12 | |
| 17 | 41.7 | 13 | |
| 18 | 47.0 | 14 | |
| 19 | Middle response | 52.9 | 15 |
| 20 | | 59.6 | 16 |

| Setting value | Machine characteristic | | Reference (setting value of MR-J3 and MR-J3W) |
|---------------|------------------------|------------------------------------------------|-----------------------------------------------|
| | Response | Guideline for machine resonance frequency [Hz] | |
| 21 | Middle response | 67.1 | 17 |
| 22 | | 75.6 | 18 |
| 23 | | 85.2 | 19 |
| 24 | | 95.9 | 20 |
| 25 | | 108.0 | 21 |
| 26 | | 121.7 | 22 |
| 27 | | 137.1 | 23 |
| 28 | | 154.4 | 24 |
| 29 | | 173.9 | 25 |
| 30 | | 195.9 | 26 |
| 31 | 220.6 | 27 | |
| 32 | 248.5 | 28 | |
| 33 | 279.9 | 29 | |
| 34 | 315.3 | 30 | |
| 35 | 355.1 | 31 | |
| 36 | 400.0 | 32 | |
| 37 | 446.6 | | |
| 38 | 501.2 | | |
| 39 | High response | 571.5 | |
| 40 | | 642.7 | |

6. NORMAL GAIN ADJUSTMENT

6.4 Manual mode

If you are not satisfied with the adjustment of auto tuning, you can adjust all gains manually.

| POINT |
|-------------------------------------------------------------------------------------------------------------------------------------------------------------------------------------------------------------------------------------------------------------|
| <p>● If machine resonance occurs, filter tuning mode selection in [Pr. PB01] or machine resonance suppression filter in [Pr. PB13] to [Pr. PB16] and [Pr. PB46] to [Pr. PB51] may be used to suppress machine resonance. (Refer to section 7.2 to 7.3.)</p> |

(1) For speed control

(a) Parameter

The following parameters are used for gain adjustment.

| Parameter | Symbol | Name |
|-----------|--------|------------------------------------------------------|
| PB06 | GD2 | Load to motor inertia ratio/load to motor mass ratio |
| PB07 | PG1 | Model loop gain |
| PB09 | VG2 | Speed loop gain |
| PB10 | VIC | Speed integral compensation |

(b) Adjustment procedure

| Step | Operation | Description |
|------|----------------------------------------------------------------------------------------------------------------------------------------------------------------------------------------------------------------------------------------------------------------------------------------|-------------------------------------------------------------------|
| 1 | Brief-adjust with auto tuning. Refer to section 6.2.3. | |
| 2 | Change the setting of auto tuning to the manual mode ([Pr. PA08]: __ __ 3). | |
| 3 | Set the estimated value to the load to motor inertia ratio/load to motor mass ratio. (If the estimate value with auto tuning is correct, setting change is not required.) | |
| 4 | Set a small value to the model loop gain. Set a large value to the speed integral compensation. | |
| 5 | Increase the speed loop gain within the vibration- and unusual noise-free range, and return slightly if vibration takes place. | Increase the speed loop gain. |
| 6 | Decrease the speed integral compensation within the vibration-free range, and return slightly if vibration takes place. | Decrease the time constant of the speed integral compensation. |
| 7 | Increase the model loop gain, and return slightly if overshoot takes place. | Increase the model loop gain. |
| 8 | If the gains cannot be increased due to mechanical system resonance or the like and the desired response cannot be achieved, response may be increased by suppressing resonance with the adaptive tuning mode or machine resonance suppression filter and then executing steps 3 to 7. | Suppression of machine resonance Refer to section 7.2 and 7.3. |
| 9 | While checking the motor status, fine-adjust each gain. | Fine adjustment |

6. NORMAL GAIN ADJUSTMENT

(c) Parameter adjustment

1) [Pr. PB09 Speed loop gain]

This parameter determines the response level of the speed control loop. Increasing this value enhances response but a too high value will make the mechanical system liable to vibrate. The actual response frequency of the speed loop is as indicated in the following expression.

$$\text{Speed loop response frequency [Hz]} = \frac{\text{Speed loop gain}}{(1 + \text{Load to motor inertia ratio}) \times 2\pi}$$

2) [Pr. PB10 Speed integral compensation]

To eliminate stationary deviation against a command, the speed control loop is under proportional integral control. For the speed integral compensation, set the time constant of this integral control. Increasing the setting lowers the response level. However, if the load to motor inertia ratio is large or the mechanical system has any vibratory element, the mechanical system is liable to vibrate unless the setting is increased to some degree. The guideline is as indicated in the following expression.

$$\begin{aligned} &\text{Speed integral compensation setting [ms]} \\ &\quad 2000 \text{ to } 3000 \\ &\geq \frac{\text{Speed loop gain}}{(1 + \text{Load to motor inertia ratio})} \end{aligned}$$

3) [Pr. PB07 Model loop gain]

This parameter determines the response level to a speed command. Increasing the value improves trackability to a speed command, but a too high value will make overshoot liable to occur at settling.

$$\text{Model loop gain guideline} \leq \frac{\text{Speed loop gain}}{(1 + \text{Load to motor inertia ratio})} \times \left(\frac{1}{4} \text{ to } \frac{1}{8} \right)$$

(2) For position control

(a) Parameter

The following parameters are used for gain adjustment.

| Parameter | Symbol | Name |
|-----------|--------|------------------------------------------------------|
| PB06 | GD2 | Load to motor inertia ratio/load to motor mass ratio |
| PB07 | PG1 | Model loop gain |
| PB08 | PG2 | Position loop gain |
| PB09 | VG2 | Speed loop gain |
| PB10 | VIC | Speed integral compensation |

6. NORMAL GAIN ADJUSTMENT

(b) Adjustment procedure

| Step | Operation | Description |
|------|----------------------------------------------------------------------------------------------------------------------------------------------------------------------------------------------------------------------------------------------------------------------------------------|-------------------------------------------------------------------|
| 1 | Brief-adjust with auto tuning. Refer to section 6.2.3. | |
| 2 | Change the setting of auto tuning to the manual mode ([Pr. PA08]: __ _ 3). | |
| 3 | Set the estimated value to the load to motor inertia ratio/load to motor mass ratio. (If the estimate value with auto tuning is correct, setting change is not required.) | |
| 4 | Set a small value to the model loop gain and the position loop gain. Set a large value to the speed integral compensation. | |
| 5 | Increase the speed loop gain within the vibration- and unusual noise-free range, and return slightly if vibration takes place. | Increase the speed loop gain. |
| 6 | Decrease the speed integral compensation within the vibration-free range, and return slightly if vibration takes place. | Decrease the time constant of the speed integral compensation. |
| 7 | Increase the position loop gain, and return slightly if vibration takes place. | Increase the position loop gain. |
| 8 | Increase the model loop gain, and return slightly if overshoot takes place. | Increase the model loop gain. |
| 9 | If the gains cannot be increased due to mechanical system resonance or the like and the desired response cannot be achieved, response may be increased by suppressing resonance with the adaptive tuning mode or machine resonance suppression filter and then executing steps 3 to 8. | Suppression of machine resonance Refer to section 7.2 and 7.3. |
| 10 | While checking the settling characteristic and motor status, fine-adjust each gain. | Fine adjustment |

(c) Parameter adjustment

1) [Pr. PB09 Speed loop gain]

This parameter determines the response level of the speed control loop. Increasing this value enhances response but a too high value will make the mechanical system liable to vibrate. The actual response frequency of the speed loop is as indicated in the following expression.

$$\text{Speed loop response frequency [Hz]} = \frac{\text{Speed loop gain}}{(1 + \text{Load to motor inertia ratio}) \times 2\pi}$$

2) [Pr. PB10 Speed integral compensation]

To eliminate stationary deviation against a command, the speed control loop is under proportional integral control. For the speed integral compensation, set the time constant of this integral control. Increasing the setting lowers the response level. However, if the load to motor inertia ratio is large or the mechanical system has any vibratory element, the mechanical system is liable to vibrate unless the setting is increased to some degree. The guideline is as indicated in the following expression.

$$\begin{aligned} & \text{Speed integral compensation setting [ms]} \\ & \geq \frac{2000 \text{ to } 3000}{\text{Speed loop gain}/(1 + \text{Load to motor inertia ratio})} \end{aligned}$$

6. NORMAL GAIN ADJUSTMENT

3) [Pr. PB08 Position loop gain]

This parameter determines the response level to a disturbance to the position control loop. Increasing the value increases the response level to the disturbance, but a too high value will increase vibration of the mechanical system.

$$\text{Position loop gain guideline} \leq \frac{\text{Speed loop gain}}{(1 + \text{Load to motor inertia ratio})} \times \left(\frac{1}{4} \text{ to } \frac{1}{8} \right)$$

4) [Pr. PB07 Model loop gain]

This parameter determines the response level to a position command. Increasing the value improves trackability to a position command, but a too high value will make overshoot liable to occur at settling.

$$\text{Model loop gain guideline} \leq \frac{\text{Speed loop gain}}{(1 + \text{Load to motor inertia ratio})} \times \left(\frac{1}{4} \text{ to } \frac{1}{8} \right)$$

6.5 2 gain adjustment mode

The 2 gain adjustment mode is used to match the position loop gains of the axes when performing the interpolation operation of servo motors of two or more axes for an X-Y table or the like. In this mode, manually set the model loop gain that determines command trackability. Other parameters for gain adjustment are set automatically.

(1) 2 gain adjustment mode 1 (interpolation mode)

The 2 gain adjustment mode 1 manually set the model loop gain that determines command trackability. The mode constantly estimates the load to motor inertia ratio, and automatically set other parameters for gain adjustment to optimum gains using auto tuning response.

The following parameters are used for 2 gain adjustment mode 1.

(a) Automatically adjusted parameter

The following parameters are automatically adjusted by auto tuning.

| Parameter | Symbol | Name |
|-----------|--------|------------------------------------------------------|
| PB06 | GD2 | Load to motor inertia ratio/load to motor mass ratio |
| PB08 | PG2 | Position loop gain |
| PB09 | VG2 | Speed loop gain |
| PB10 | VIC | Speed integral compensation |

(b) Manually adjusted parameter

The following parameters are adjustable manually.

| Parameter | Symbol | Name |
|-----------|--------|----------------------|
| PA09 | RSP | Auto tuning response |
| PB07 | PG1 | Model loop gain |

6. NORMAL GAIN ADJUSTMENT

(2) 2 gain adjustment mode 2

Use 2 gain adjustment mode 2 when proper gain adjustment cannot be made with 2 gain adjustment mode 1. Since the load to motor inertia ratio is not estimated in this mode, set the value of a proper load to motor inertia ratio in [Pr. PB06].

The following parameters are used for 2 gain adjustment mode 2.

(a) Automatically adjusted parameter

The following parameters are automatically adjusted by auto tuning.

| Parameter | Symbol | Name |
|-----------|--------|-----------------------------|
| PB08 | PG2 | Position loop gain |
| PB09 | VG2 | Speed loop gain |
| PB10 | VIC | Speed integral compensation |

(b) Manually adjusted parameter

The following parameters are adjustable manually.

| Parameter | Symbol | Name |
|-----------|--------|------------------------------------------------------|
| PA09 | RSP | Auto tuning response |
| PB06 | GD2 | Load to motor inertia ratio/load to motor mass ratio |
| PB07 | PG1 | Model loop gain |

(3) Adjustment procedure of 2 gain adjustment mode

| POINT |
|--------------------------------------------------------------------------------------------------------|
| <p>● Set the same value in [Pr. PB07 Model loop gain] for the axis used in 2 gain adjustment mode.</p> |

| Step | Operation | Description |
|------|-------------------------------------------------------------------------------------------------------------------------------------------------------------------------------------------------------|-----------------------------------------------------------|
| 1 | Set to the auto tuning mode. | Select the auto tuning mode 1. |
| 2 | During operation, increase the response level setting value in [Pr. PA09], and return the setting if vibration occurs. | Adjustment in auto tuning mode 1. |
| 3 | Check value of the model loop gain and the load to motor inertia ratio in advance. | Check the upper setting limits. |
| 4 | Set the 2 gain adjustment mode 1 ([Pr. PA08]: ___ 0). | Select the 2 gain adjustment mode 1 (interpolation mode). |
| 5 | When the load to motor inertia ratio is different from the design value, select the 2 gain adjustment mode 2 ([Pr. PA08]: ___ 4) and then set the load to motor inertia ratio manually in [Pr. PB06]. | Check the load to motor inertia ratio. |
| 6 | Set the model loop gain of all the axes to be interpolated to the same value. At that time, adjust to the setting value of the axis, which has the smallest model loop gain. | Set model loop gain. |
| 7 | Considering the interpolation characteristic and motor status, fine-adjust the model loop gain and response level setting. | Fine adjustment |

6. NORMAL GAIN ADJUSTMENT

(4) Parameter adjustment

[Pr. PB07 Model loop gain]

This parameter determines the response level of the position control loop. Increasing the value improves trackability to a position command, but a too high value will make overshoot liable to occur at settling.

Number of droop pulses is determined by the following expression.

$$\text{Number of droop pulses [pulse]} = \frac{\text{Position command frequency [pulse/s]}}{\text{Model loop gain setting}}$$

Position command frequency differs depending on the operation mode.

Rotary servo motor and direct drive motor:

Position command frequency

$$= \frac{\text{Speed [r/min]}}{60} \times \text{Encoder resolution (number of pulses per servo motor revolution)}$$

Linear servo motor:

$$\text{Position command frequency} = \text{Speed [mm/s]} \div \text{Encoder resolution (travel distance per pulse)}$$

7. SPECIAL ADJUSTMENT FUNCTIONS

7. SPECIAL ADJUSTMENT FUNCTIONS

| POINT | |
|-----------------------------|-------------------------------------------------------------------------------------------------------------------------------------------------------------------------------|
| ● | The functions given in this chapter need not be used normally. Use them if you are not satisfied with the machine status after making adjustment in the methods in chapter 6. |
| ● | When you use a linear servo motor, replace the following words in the left to the words in the right. |
| Load to motor inertia ratio | → Load to motor mass ratio |
| Torque | → Thrust |
| (Servo motor) speed | → (Linear servo motor) speed |

7.1 Filter setting

The following filters are available with MR-J4 servo amplifiers.

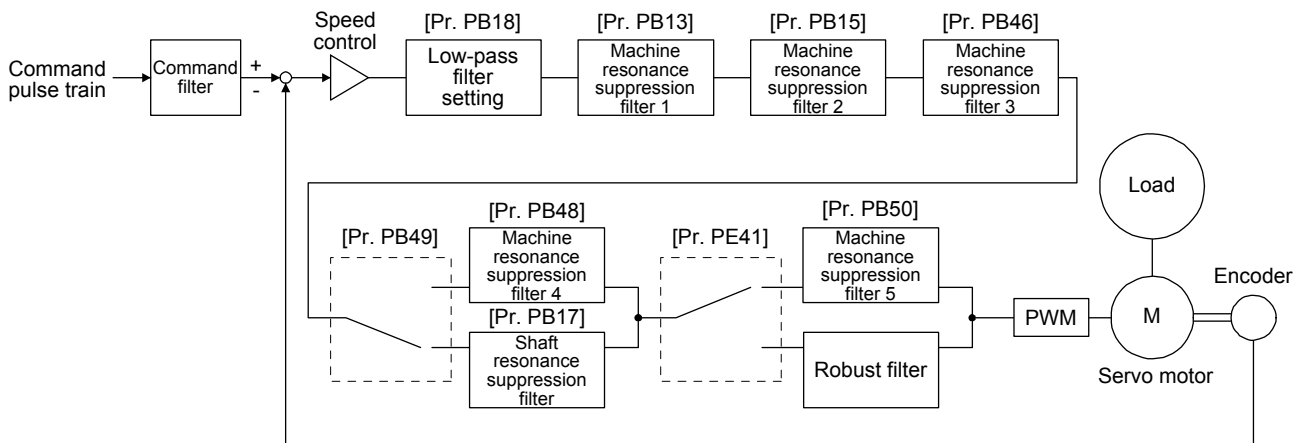

7. SPECIAL ADJUSTMENT FUNCTIONS

7.1.1 Machine resonance suppression filter

| POINT |
|----------------------------------------------------------------------------------------------------------------------------------------------------------------------------------------------------------------------------------------------------------------------------------------------------------------------------------------------------------------------------------------------------------------------------------------------------------------------------------------------------------------------------------------------------------------------------------------------------------------------------------------------------------------------------------------------------------------------------------------------------------------------------------------------------------------------------------------------------------------------------------------------------------------------------------------------------------|
| <ul style="list-style-type: none">● The machine resonance suppression filter is a delay factor for the servo system. Therefore, vibration may increase if you set an incorrect resonance frequency or set notch characteristics too deep or too wide.● If the frequency of machine resonance is unknown, decrease the notch frequency from higher to lower ones in order. The optimum notch frequency is set at the point where vibration is minimal.● A deeper notch has a higher effect on machine resonance suppression but increases a phase delay and may increase vibration.● A wider notch has a higher effect on machine resonance suppression but increases a phase delay and may increase vibration.● The machine characteristic can be grasped beforehand by the machine analyzer on MR Configurator2. This allows the required notch frequency and notch characteristics to be determined. |

If a mechanical system has a unique resonance point, increasing the servo system response level may cause resonance (vibration or unusual noise) in the mechanical system at that resonance frequency. Using the machine resonance suppression filter and adaptive tuning can suppress the resonance of the mechanical system. The setting range is 10 Hz to 4500 Hz.

7. SPECIAL ADJUSTMENT FUNCTIONS

(1) Function

The machine resonance suppression filter is a filter function (notch filter) which decreases the gain of the specific frequency to suppress the resonance of the mechanical system. You can set the gain decreasing frequency (notch frequency), gain decreasing depth and width.

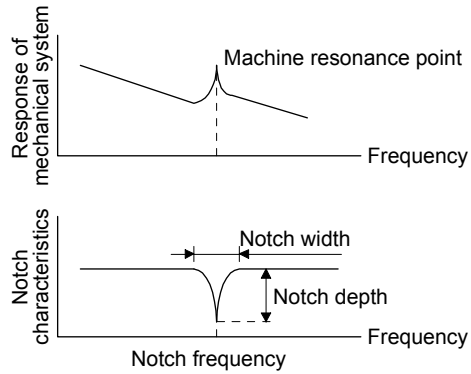

You can set five machine resonance suppression filters at most.

| Filter | Setting parameter | Precaution | Parameter that is reset with vibration tough drive function | Parameter automatically adjusted with one-touch tuning |
|----------------------------------------|-------------------|---------------------------------------------------------------------------------------------------------------------------------------------------------------------------------------------------------------------------------------------------------------------------------------------------------------------|-------------------------------------------------------------|--------------------------------------------------------|
| Machine resonance suppression filter 1 | PB01/PB13/PB14 | The filter can be set automatically with "Filter tuning mode selection" in [Pr. PB01]. | PB13 | PB01/PB13/PB14 |
| Machine resonance suppression filter 2 | PB15/PB16 | | PB15 | PB15/PB16 |
| Machine resonance suppression filter 3 | PB46/PB47 | | PB47 | |
| Machine resonance suppression filter 4 | PB48/PB49 | Enabling the machine resonance suppression filter 4 disables the shaft resonance suppression filter. Using the shaft resonance suppression filter is recommended because it is adjusted properly depending on the usage situation. The shaft resonance suppression filter is enabled for the initial setting. | | PB48/PB49 |
| Machine resonance suppression filter 5 | PB50/PB51 | Enabling the robust filter disables the machine resonance suppression filter 5. The robust filter is disabled for the initial setting. | | PB51 |

7. SPECIAL ADJUSTMENT FUNCTIONS

(2) Parameter

(a) Machine resonance suppression filter 1 ([Pr. PB13] and [Pr. PB14])

Set the notch frequency, notch depth and notch width of the machine resonance suppression filter 1 ([Pr. PB13] and [Pr. PB14])

When you select "Manual setting (_ _ _ 2)" of "Filter tuning mode selection" in [Pr. PB01], the setting of the machine resonance suppression filter 1 is enabled.

(b) Machine resonance suppression filter 2 ([Pr. PB15] and [Pr. PB16])

To use this filter, select "Enabled (_ _ _ 1)" of "Machine resonance suppression filter 2 selection" in [Pr. PB16].

How to set the machine resonance suppression filter 2 ([Pr. PB15] and [Pr. PB16]) is the same as for the machine resonance suppression filter 1 ([Pr. PB13] and [Pr. PB14]).

(c) Machine resonance suppression filter 3 ([Pr. PB46] and [Pr. PB47])

To use this filter, select "Enabled (_ _ _ 1)" of "Machine resonance suppression filter 3 selection" in [Pr. PB47].

How to set the machine resonance suppression filter 3 ([Pr. PB46] and [Pr. PB47]) is the same as for the machine resonance suppression filter 1 ([Pr. PB13] and [Pr. PB14]).

(d) Machine resonance suppression filter 4 ([Pr. PB48] and [Pr. PB49])

To use this filter, select "Enabled (_ _ _ 1)" of "Machine resonance suppression filter 4 selection" in [Pr. PB49]. However, enabling the machine resonance suppression filter 4 disables the shaft resonance suppression filter.

How to set the machine resonance suppression filter 4 ([Pr. PB48] and [Pr. PB49]) is the same as for the machine resonance suppression filter 1 ([Pr. PB13] and [Pr. PB14]).

(e) Machine resonance suppression filter 5 ([Pr. PB50] and [Pr. PB51])

To use this filter, select "Enabled (_ _ _ 1)" of "Machine resonance suppression filter 5 selection" in [Pr. PB51]. However, enabling the robust filter ([Pr. PE41: _ _ _ 1]) disables the machine resonance suppression filter 5.

How to set the machine resonance suppression filter 5 ([Pr. PB50] and [Pr. PB51]) is the same as for the machine resonance suppression filter 1 ([Pr. PB13] and [Pr. PB14]).

7. SPECIAL ADJUSTMENT FUNCTIONS

7.1.2 Adaptive filter II

| POINT |
|----------------------------------------------------------------------------------------------------------------------------------------------------------------------------------------------------------------------------------------------------------------------------------------------------------------------------------------------------------------------------------------------------------------------------------------------------------------------------------------------------------------------------------------------------------------------------------------------------------------------------------------------------------------------------------------------------------------------------------------------------------------------------------------------------------------------------------------------------------------------------------------------------------------------------------------------------------------------------------------------------------------------------------------------------------------------------------------------------------------------------------------------------------------------------------------------------------------------------------------------------------------------------------------------------------------------------------------------------------------------------------------------------------------------------------------------------------------------------|
| <ul style="list-style-type: none"> ● The machine resonance frequency which adaptive filter II (adaptive tuning) can respond to is about 100 Hz to 2.25 kHz. As for the resonance frequency out of the range, set manually. ● When adaptive tuning is executed, vibration sound increases as an excitation signal is forcibly applied for several seconds. ● When adaptive tuning is executed, machine resonance is detected for a maximum of 10 seconds and a filter is generated. After filter generation, the adaptive tuning mode automatically shifts to the manual setting. ● Adaptive tuning generates the optimum filter with the currently set control gains. If vibration occurs when the response setting is increased, execute adaptive tuning again. ● During adaptive tuning, a filter having the best notch depth at the set control gain is generated. To allow a filter margin against machine resonance, increase the notch depth in the manual setting. ● Adaptive vibration suppression control may provide no effect on a mechanical system which has complex resonance characteristics. ● Adaptive tuning in the high accuracy mode is available with servo amplifiers with software version C5 or later. The frequency is estimated more accurately in the high accuracy mode compared to the standard mode. However, the tuning sound may be larger in the high accuracy mode. |

(1) Function

Adaptive filter II (adaptive tuning) is a function in which the servo amplifier detects machine vibration for a predetermined period of time and sets the filter characteristics automatically to suppress mechanical system vibration. Since the filter characteristics (frequency, depth) are set automatically, you need not be conscious of the resonance frequency of a mechanical system.

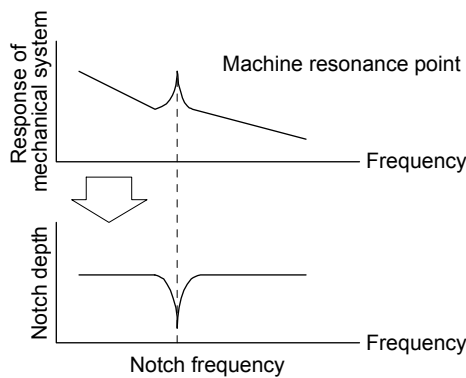

When machine resonance is large and frequency is low

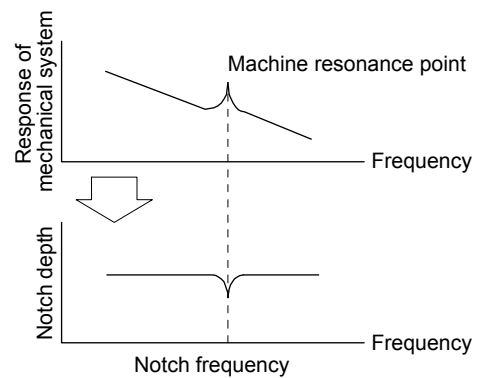

When machine resonance is small and frequency is high

7. SPECIAL ADJUSTMENT FUNCTIONS

(2) Parameter

Select how to set the filter tuning in [Pr. PB01 Adaptive tuning mode (adaptive filter II)].

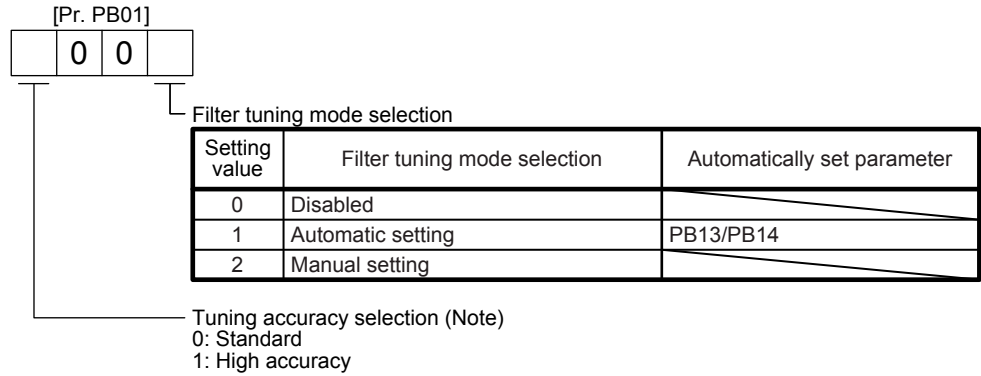

Note. This digit is available with servo amplifier with software version C5 or later.

(3) Adaptive tuning mode procedure

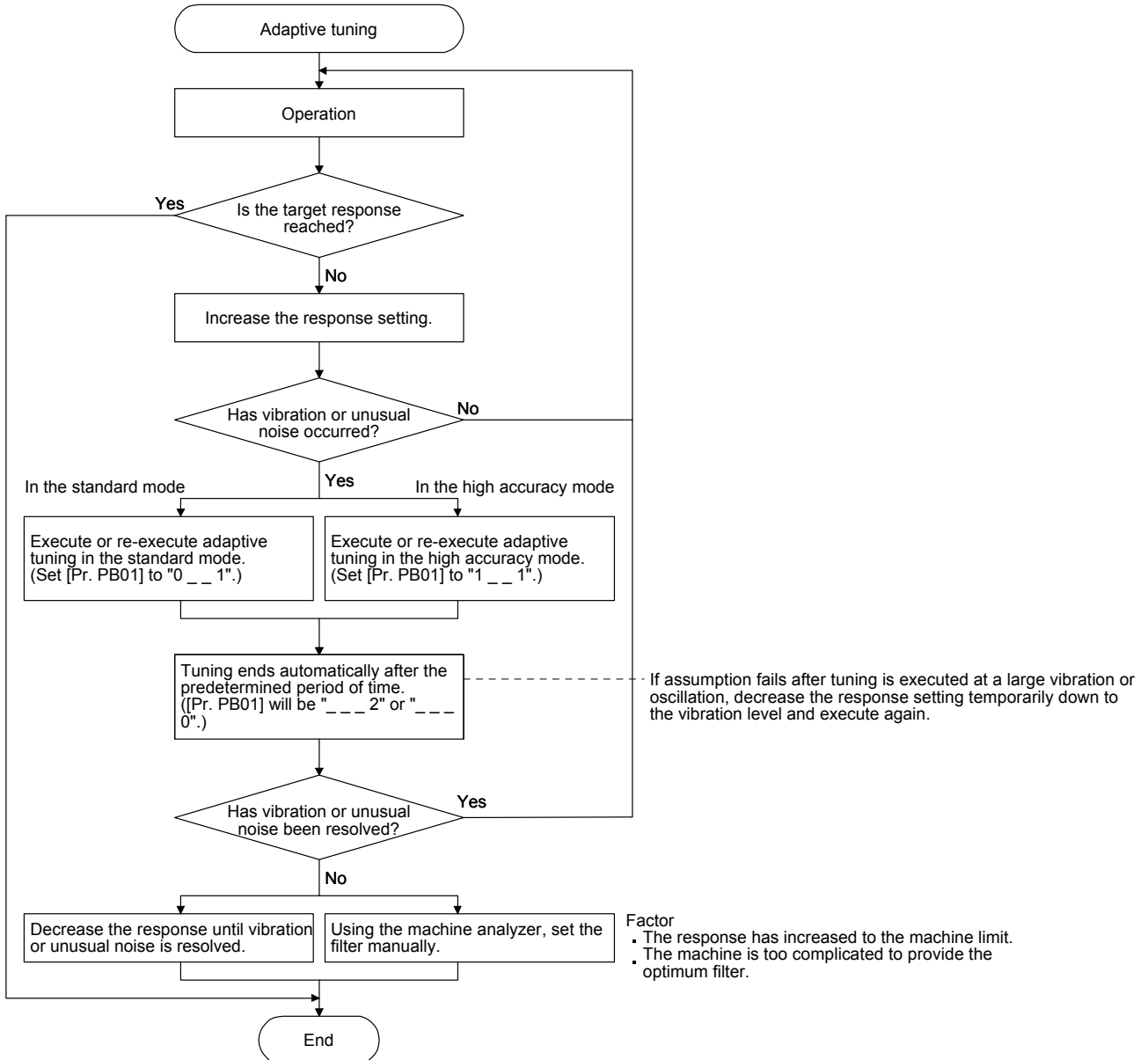

7. SPECIAL ADJUSTMENT FUNCTIONS

7.1.3 Shaft resonance suppression filter

| POINT |
|------------------------------------------------------------------------------------------------------------------------------------------------------------------------------------------------------------------------------------------------------------------------------------------------------------------------------------------------|
| <p>● This filter is set properly by default according to servo motor you use and load moment of inertia. It is recommended that [Pr. PB23] be set to "___ 0" (automatic setting) because changing "Shaft resonance suppression filter selection" in [Pr. PB23] or [Pr. PB17 Shaft resonance suppression filter] may lower the performance.</p> |

(1) Function

When a load is mounted to the servo motor shaft, resonance by shaft torsion during driving may generate a mechanical vibration at high frequency. The shaft resonance suppression filter suppresses the vibration.

When you select "Automatic setting", the filter will be set automatically on the basis of the servo motor you use and the load to motor inertia ratio. The disabled setting increases the response of the servo amplifier for high resonance frequency.

(2) Parameter

Set "Shaft resonance suppression filter selection" in [Pr. PB23].

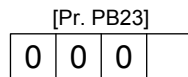

Shaft resonance suppression filter selection
 0: Automatic setting
 1: Manual setting
 2: Disabled

To set [Pr. PB17 Shaft resonance suppression filter] automatically, select "Automatic setting".

To set [Pr. PB17 Shaft resonance suppression filter] manually, select "Manual setting". The setting values are as follows.

Shaft resonance suppression filter setting frequency selection

| Setting value | Frequency [Hz] | Setting value | Frequency [Hz] |
|---------------|----------------|---------------|----------------|
| __ 0 0 | Disabled | __ 1 0 | 562 |
| __ 0 1 | Disabled | __ 1 1 | 529 |
| __ 0 2 | 4500 | __ 1 2 | 500 |
| __ 0 3 | 3000 | __ 1 3 | 473 |
| __ 0 4 | 2250 | __ 1 4 | 450 |
| __ 0 5 | 1800 | __ 1 5 | 428 |
| __ 0 6 | 1500 | __ 1 6 | 409 |
| __ 0 7 | 1285 | __ 1 7 | 391 |
| __ 0 8 | 1125 | __ 1 8 | 375 |
| __ 0 9 | 1000 | __ 1 9 | 360 |
| __ 0 A | 900 | __ 1 A | 346 |
| __ 0 B | 818 | __ 1 B | 333 |
| __ 0 C | 750 | __ 1 C | 321 |
| __ 0 D | 692 | __ 1 D | 310 |
| __ 0 E | 642 | __ 1 E | 300 |
| __ 0 F | 600 | __ 1 F | 290 |

7. SPECIAL ADJUSTMENT FUNCTIONS

7.1.4 Low-pass filter

(1) Function

When a ball screw or the like is used, resonance of high frequency may occur as the response level of the servo system is increased. To prevent this, the low-pass filter is enabled for a torque command as a default. The filter frequency of the low-pass filter is automatically adjusted to the value in the following equation.

$$\text{Filter frequency ([rad/s])} = \frac{VG2}{1 + GD2} \times 10$$

However, when an automatically adjusted value is smaller than VG2, the filter frequency will be the VG2 value.

To set [Pr. PB18] manually, select "Manual setting (_ _ 1 _)" of "Low-pass filter selection" in [Pr. PB23].

(2) Parameter

Set "Low-pass filter selection" in [Pr. PB23].

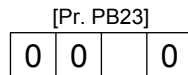

Low-pass filter selection
 0: Automatic setting
 1: Manual setting
 2: Disabled

7.1.5 Advanced vibration suppression control II

| POINT |
|--------------------------------------------------------------------------------------------------------------------------------------------------------------------------------------------------------------------------------------------------------------------------------------------------------------------------------------------------------------------------------------------------------------------------------------------------------------------------------------------------------------------------------------------------------------------------------------------------------------------------------------------------------------------------------------------------------------------------------------------------------------------------------------------------------------------------------------------------------------------------------------------------------------------------------------------------------------------------------------------------------------------------------------------------------------------------------------------------------------------------------------------------------------------------------------------|
| <ul style="list-style-type: none"> ● The function is enabled when "Gain adjustment mode selection" in [Pr. PA08] is "Auto tuning mode 2 (_ _ _ 2)", "Manual mode (_ _ _ 3)", or "2 gain adjustment mode 2 (_ _ _ 4)". ● The machine resonance frequency supported in the vibration suppression control tuning mode is 1.0 Hz to 100.0 Hz. As for the vibration out of the range, set manually. ● Stop the servo motor before changing the vibration suppression control-related parameters. Otherwise, it may cause an unexpected operation. ● For positioning operation during execution of vibration suppression control tuning, provide a stop time to ensure a stop after vibration damping. ● Vibration suppression control tuning may not make normal estimation if the residual vibration at the servo motor side is small. ● Vibration suppression control tuning sets the optimum parameter with the currently set control gains. When the response setting is increased, set vibration suppression control tuning again. ● When using the vibration suppression control 2, set " _ _ _ 1" in [Pr. PA24]. |

7. SPECIAL ADJUSTMENT FUNCTIONS

(1) Function

Vibration suppression control is used to further suppress load-side vibration, such as work-side vibration and base shake. The servo motor-side operation is adjusted for positioning so that the machine does not vibrate.

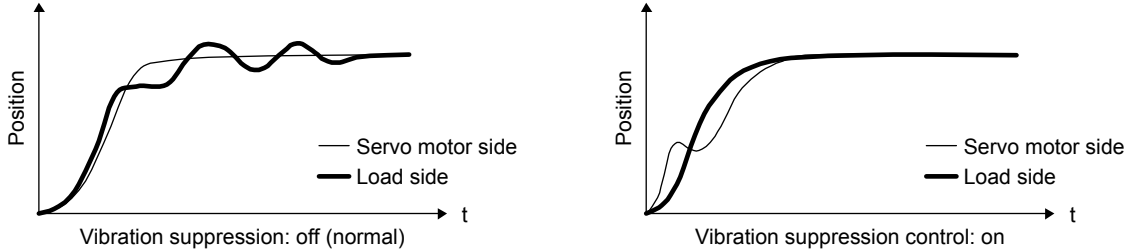

When the advanced vibration suppression control II ([Pr. PB02 Vibration suppression control tuning mode]) is executed, the vibration frequency at load side is automatically estimated to suppress machine side vibration two times at most.

In the vibration suppression control tuning mode, this mode shifts to the manual setting after the positioning operation is performed the predetermined number of times. For manual setting, adjust the vibration suppression control 1 with [Pr. PB19] to [Pr. PB22] and vibration suppression control 2 with [Pr. PB52] to [Pr. PB55].

(2) Parameter

Set [Pr. PB02 Vibration suppression control tuning mode (advanced vibration suppression control II)]. When you use a vibration suppression control, set "Vibration suppression control 1 tuning mode selection". When you use two vibration suppression controls, set "Vibration suppression control 2 tuning mode selection" in addition.

[Pr. PB02]
0 0

Vibration suppression control 1 tuning mode

| Setting value | Vibration suppression control 1 tuning mode selection | Automatically set parameter |
|---------------|-------------------------------------------------------|-----------------------------|
| __ _ 0 | Disabled | |
| __ _ 1 | Automatic setting | PB19/PB20/PB21/PB22 |
| __ _ 2 | Manual setting | |

Vibration suppression control 2 tuning mode

| Setting value | Vibration suppression control 2 tuning mode selection | Automatically set parameter |
|---------------|-------------------------------------------------------|-----------------------------|
| __ 0 _ | Disabled | |
| __ 1 _ | Automatic setting | PB52/PB53/PB54/PB55 |
| __ 2 _ | Manual setting | |

7. SPECIAL ADJUSTMENT FUNCTIONS

(3) Vibration suppression control tuning procedure

The following flow chart is for the vibration suppression control 1. For the vibration suppression control 2, set " __ 1 _" in [Pr. PB02] to execute the vibration suppression control tuning.

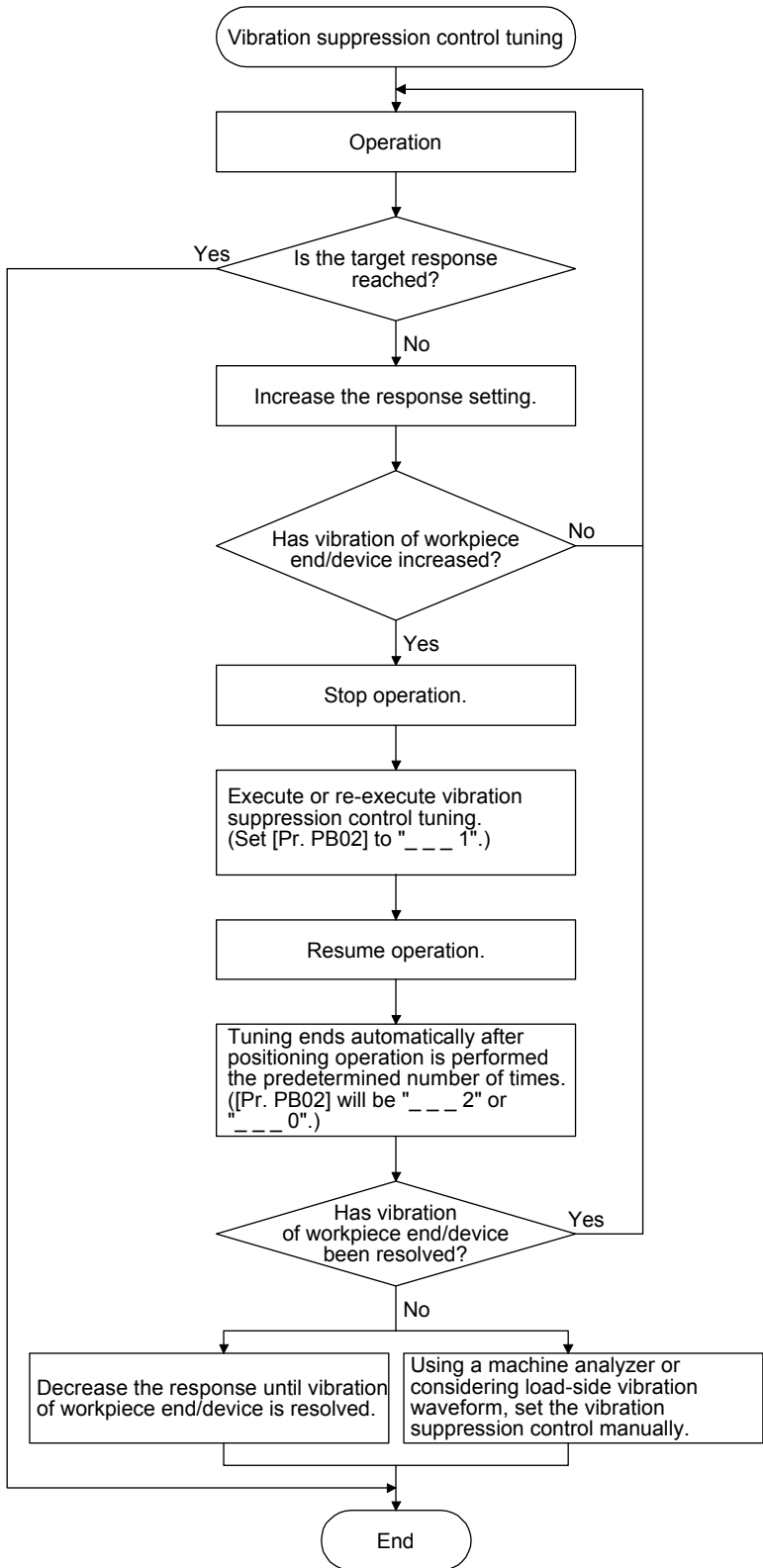

Factor

- Estimation cannot be made as load-side vibration has not been transmitted to the servo motor side.
- The response of the model loop gain has increased to the load-side vibration frequency (vibration suppression control limit).

7. SPECIAL ADJUSTMENT FUNCTIONS

(4) Vibration suppression control manual mode

| POINT |
|----------------------------------------------------------------------------------------------------------------------------------------------------------------------------------------------------------------------------------------------------------------------------------------------------------------------------------------------------------------------------------------------------------------------------------------------------------------------------------------------------------------------------------------------------------------------------------------------------------------------------------------------------------------------------------------|
| <ul style="list-style-type: none"> ● When load-side vibration does not show up in servo motor-side vibration, the setting of the servo motor-side vibration frequency does not produce an effect. ● When the anti-resonance frequency and resonance frequency can be confirmed using the machine analyzer or external equipment, do not set the same value but set different values to improve the vibration suppression performance. ● The setting range of [Pr. PB19], [Pr. PB20], [Pr. PB52], and [Pr. PB53] varies, depending on the value in [Pr. PB07]. If a value out of the range is set, the vibration suppression control will be disabled. |

Measure work-side vibration and device shake with the machine analyzer or external measuring instrument, and set the following parameters to adjust vibration suppression control manually.

| Setting item | Vibration suppression control 1 | Vibration suppression control 2 |
|-------------------------------------------------------------|---------------------------------|---------------------------------|
| Vibration suppression control - Vibration frequency | [Pr. PB19] | [Pr. PB52] |
| Vibration suppression control - Resonance frequency | [Pr. PB20] | [Pr. PB53] |
| Vibration suppression control - Vibration frequency damping | [Pr. PB21] | [Pr. PB54] |
| Vibration suppression control - Resonance frequency damping | [Pr. PB22] | [Pr. PB55] |

7. SPECIAL ADJUSTMENT FUNCTIONS

- Step 1 Select "Manual setting (_ _ 2)" of "Vibration suppression control 1 tuning mode selection" or "Manual setting (_ _ 2 _)" of "Vibration suppression control 2 tuning mode selection" in [Pr. PB02].
- Step 2 Set "Vibration suppression control - Vibration frequency" and "Vibration suppression control - Resonance frequency" as follows.

However, the value of [Pr. PB07 Model loop gain], vibration frequency, and resonance frequency have the following usable range and recommended range.

| Vibration suppression control | Usable range | Recommended setting range |
|---------------------------------|------------------------------------------------------------------------------------------------------------------------------------------------------------------------------------------------------------------------------------------------|----------------------------------------------------------------------------------------------------------------------------------------------------------------------------------------------|
| Vibration suppression control 1 | $[Pr. PB19] > 1/2\pi \times (0.9 \times [Pr. PB07])$ $[Pr. PB20] > 1/2\pi \times (0.9 \times [Pr. PB07])$ | $[Pr. PB19] > 1/2\pi \times (1.5 \times [Pr. PB07])$ $[Pr. PB20] > 1/2\pi \times (1.5 \times [Pr. PB07])$ |
| Vibration suppression control 2 | When $[Pr. PB19] < [Pr. PB52]$, $[Pr. PB52] > (5.0 + 0.1 \times [Pr. PB07])$ $[Pr. PB53] > (5.0 + 0.1 \times [Pr. PB07])$ $1.1 < [Pr. PB52]/[Pr. PB19] < 5.5$ $[Pr. PB07] < 2\pi (0.3 \times [Pr. PB19] + 1/8 \times [Pr. PB52])$ | When $[Pr. PB19] < [Pr. PB52]$, $[Pr. PB52], [Pr. PB53] > 6.25 \text{ Hz}$ $1.1 < [Pr. PB52]/[Pr. PB19] < 4$ $[Pr. PB07] < 1/3 \times (4 \times [Pr. PB19] + 2 \times [Pr. PB52])$ |

- (a) When a vibration peak can be confirmed with machine analyzer using MR Configurator2, or external equipment.

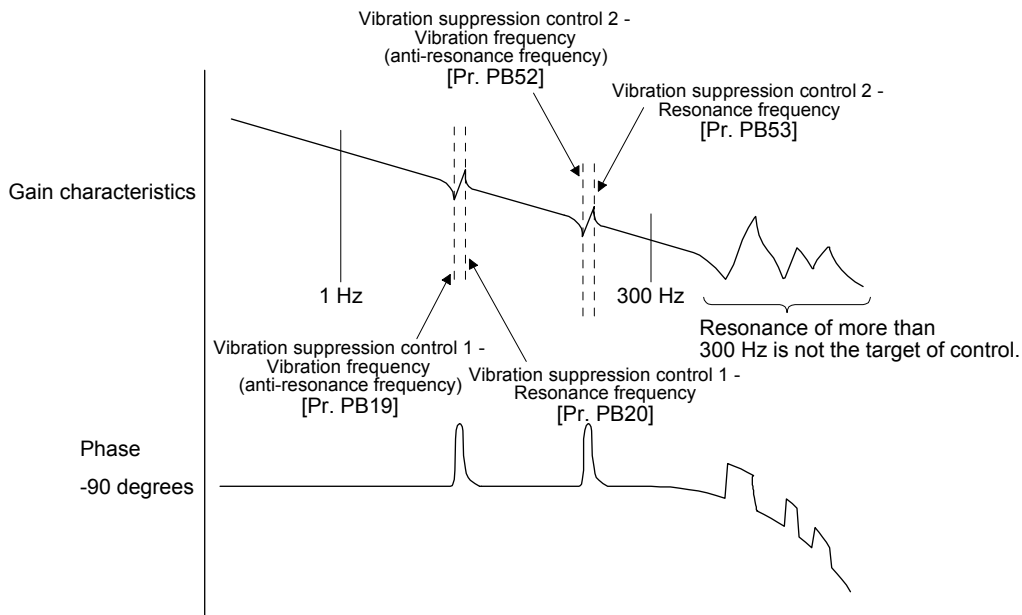

- (b) When vibration can be confirmed using monitor signal or external sensor

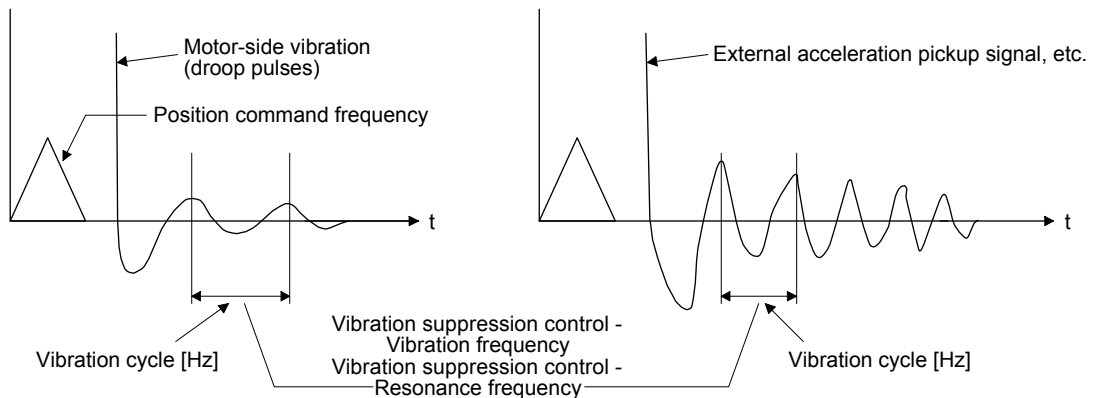

Set the same value.

- Step 3 Fine-adjust "Vibration suppression control - Vibration frequency damping" and "Vibration suppression control - Resonance frequency damping".

7. SPECIAL ADJUSTMENT FUNCTIONS

7.1.6 Command notch filter

| POINT |
|--------------------------------------------------------------------------------------------------------------------------------------------------------------------------------------------------------------------------------------------------------------------------------------------------------------------------------------------------------------------------------------------------------------------------------------------------------------------------------------------------------------------------------------------------------------------------------------------------------------------------------------------------------------|
| <ul style="list-style-type: none">● By using the advanced vibration suppression control II and the command notch filter, the load-side vibration of three frequencies can be suppressed.● The frequency range of machine vibration, which can be supported by the command notch filter, is between 4.5 Hz and 2250 Hz. Set a frequency close to the machine vibration frequency and within the range.● When [Pr. PB45 Command notch filter] is changed during the positioning operation, the changed setting is not reflected. The setting is reflected approximately 150 ms after the servo motor stops (after servo-lock). |

(1) Function

Command notch filter has a function that lowers the gain of the specified frequency contained in a position command. By lowering the gain, load-side vibration, such as work-side vibration and base shake, can be suppressed. Which frequency to lower the gain and how deep to lower the gain can be set.

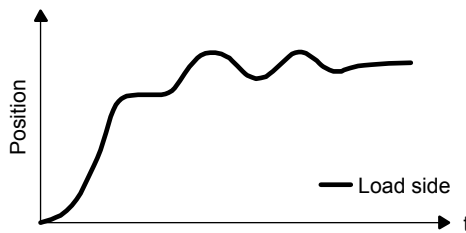

Command notch filter: disabled

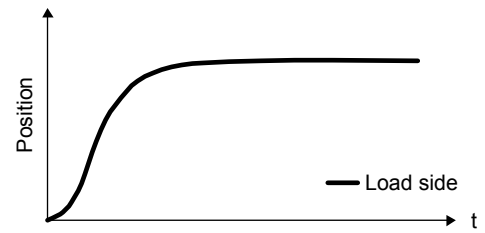

Command notch filter: enabled

7. SPECIAL ADJUSTMENT FUNCTIONS

(2) Parameter

Set [Pr. PB45 Command notch filter] as shown below. For the command notch filter setting frequency, set the closest value to the vibration frequency [Hz] at the load side.

[Pr. PB45]

| | | | |
|---|--|--|--|
| 0 | | | |
|---|--|--|--|

Notch depth

| Setting value | Depth [dB] |
|---------------|------------|
| 0 | -40.0 |
| 1 | -24.1 |
| 2 | -18.1 |
| 3 | -14.5 |
| 4 | -12.0 |
| 5 | -10.1 |
| 6 | -8.5 |
| 7 | -7.2 |
| 8 | -6.0 |
| 9 | -5.0 |
| A | -4.1 |
| B | -3.3 |
| C | -2.5 |
| D | -1.8 |
| E | -1.2 |
| F | -0.6 |

Command notch filter setting frequency

| Setting value | Frequency [Hz] | Setting value | Frequency [Hz] | Setting value | Frequency [Hz] |
|---------------|----------------|---------------|----------------|---------------|----------------|
| 00 | Disabled | 20 | 70 | 40 | 17.6 |
| 01 | 2250 | 21 | 66 | 41 | 16.5 |
| 02 | 1125 | 22 | 62 | 42 | 15.6 |
| 03 | 750 | 23 | 59 | 43 | 14.8 |
| 04 | 562 | 24 | 56 | 44 | 14.1 |
| 05 | 450 | 25 | 53 | 45 | 13.4 |
| 06 | 375 | 26 | 51 | 46 | 12.8 |
| 07 | 321 | 27 | 48 | 47 | 12.2 |
| 08 | 281 | 28 | 46 | 48 | 11.7 |
| 09 | 250 | 29 | 45 | 49 | 11.3 |
| 0A | 225 | 2A | 43 | 4A | 10.8 |
| 0B | 204 | 2B | 41 | 4B | 10.4 |
| 0C | 187 | 2C | 40 | 4C | 10.0 |
| 0D | 173 | 2D | 38 | 4D | 9.7 |
| 0E | 160 | 2E | 37 | 4E | 9.4 |
| 0F | 150 | 2F | 36 | 4F | 9.1 |
| 10 | 140 | 30 | 35.2 | 50 | 8.8 |
| 11 | 132 | 31 | 33.1 | 51 | 8.3 |
| 12 | 125 | 32 | 31.3 | 52 | 7.8 |
| 13 | 118 | 33 | 29.6 | 53 | 7.4 |
| 14 | 112 | 34 | 28.1 | 54 | 7.0 |
| 15 | 107 | 35 | 26.8 | 55 | 6.7 |
| 16 | 102 | 36 | 25.6 | 56 | 6.4 |
| 17 | 97 | 37 | 24.5 | 57 | 6.1 |
| 18 | 93 | 38 | 23.4 | 58 | 5.9 |
| 19 | 90 | 39 | 22.5 | 59 | 5.6 |
| 1A | 86 | 3A | 21.6 | 5A | 5.4 |
| 1B | 83 | 3B | 20.8 | 5B | 5.2 |
| 1C | 80 | 3C | 20.1 | 5C | 5.0 |
| 1D | 77 | 3D | 19.4 | 5D | 4.9 |
| 1E | 75 | 3E | 18.8 | 5E | 4.7 |
| 1F | 72 | 3F | 18.2 | 5F | 4.5 |

7. SPECIAL ADJUSTMENT FUNCTIONS

7.2 Gain switching function

You can switch gains with the function. You can switch gains during rotation and during stop, and can use a control command from a controller to switch gains during operation.

7.2.1 Applications

The following shows when you use the function.

- (1) You want to increase the gains during servo-lock but decrease the gains to reduce noise during rotation.
- (2) You want to increase the gains during settling to shorten the stop settling time.
- (3) You want to change the gains using a control command from a controller to ensure stability of the servo system since the load to motor inertia ratio varies greatly during a stop (e.g. a large load is mounted on a carrier).

7. SPECIAL ADJUSTMENT FUNCTIONS

7.2.2 Function block diagram

The control gains, load to motor inertia ratio, and vibration suppression control settings are changed according to the conditions selected by [Pr. PB26 Gain switching function] and [Pr. PB27 Gain switching condition].

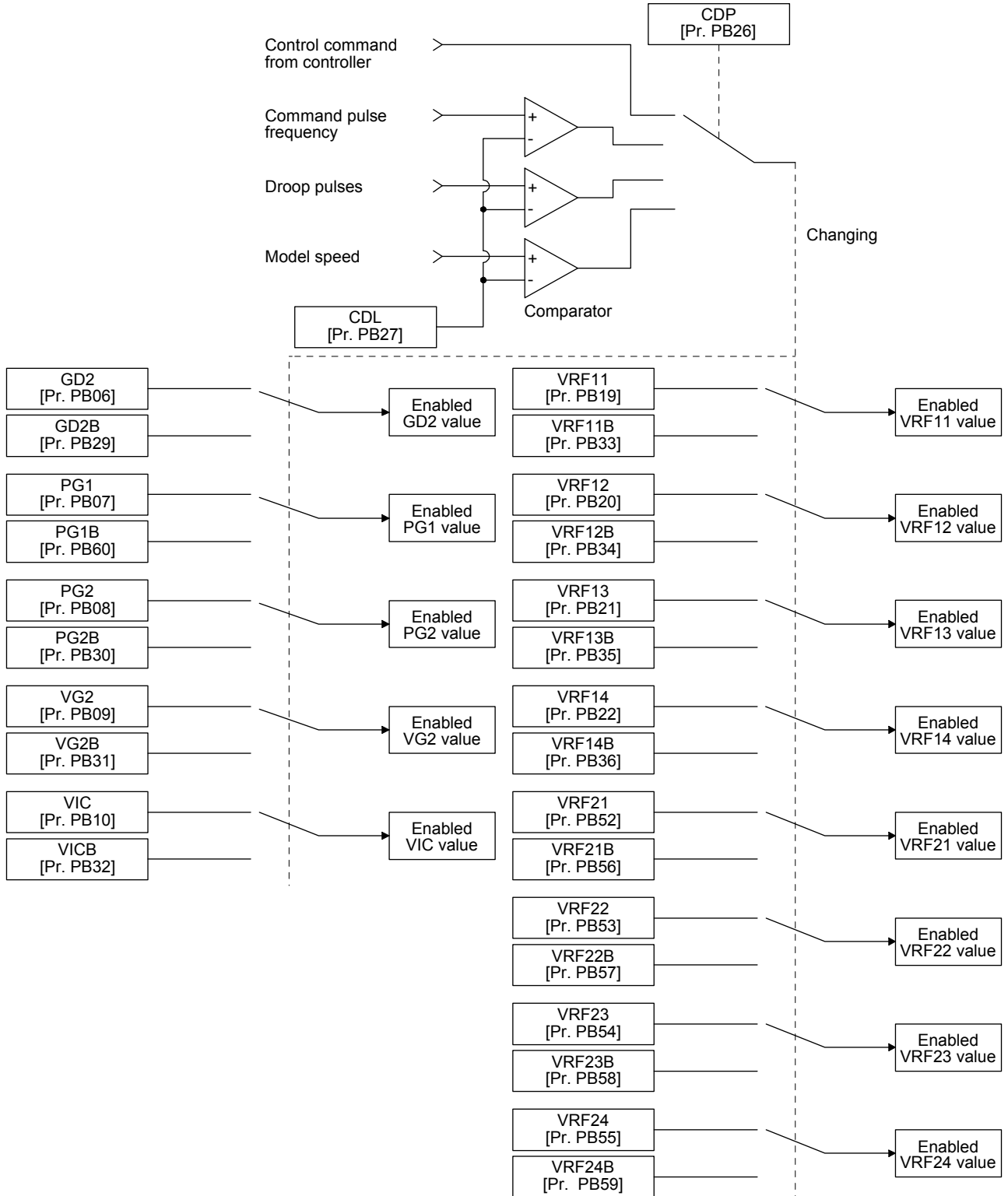

7. SPECIAL ADJUSTMENT FUNCTIONS

7.2.3 Parameter

When using the gain switching function, always select "Manual mode (_ _ _ 3)" of "Gain adjustment mode selection" in [Pr. PA08 Auto tuning mode]. The gain switching function cannot be used in the auto tuning mode.

(1) Parameter for setting gain switching condition

| Parameter | Symbol | Name | Unit | Description |
|-----------|--------|------------------------------|------------------------------------|--------------------------------------------------------------|
| PB26 | CDP | Gain switching function | | Select a switching condition. |
| PB27 | CDL | Gain switching condition | [kpulse/s] /[pulse] /[r/min] | Set a switching condition values. |
| PB28 | CDT | Gain switching time constant | [ms] | Set the filter time constant for a gain switch at switching. |

(a) [Pr. PB26 Gain switching function]

Set gain switching conditions. Select the switching condition in the first to third digits.

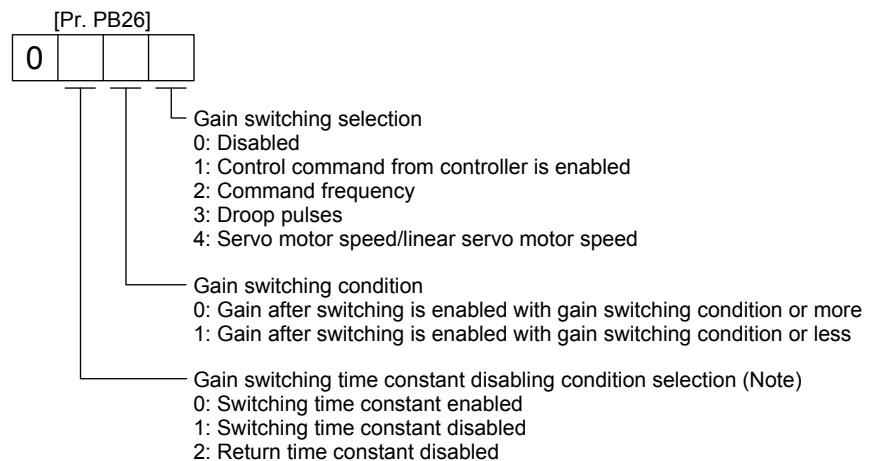

Note. This digit is available with servo amplifier with software version B4 or later.

(b) [Pr. PB27 Gain switching condition]

Set a level to switch gains with [Pr. PB27] after you select "Command frequency", "Droop pulses", or "Servo motor speed/linear servo motor speed" with the gain switching selection in [Pr. PB26 Gain switching function].

The setting unit is as follows.

| Gain switching condition | Unit |
|--------------------------------------------|----------------|
| Command frequency | [kpulse/s] |
| Droop pulses | [pulse] |
| Servo motor speed/linear servo motor speed | [r/min]/[mm/s] |

(c) [Pr. PB28 Gain switching time constant]

You can set the primary delay filter to each gain at gain switching. Use this parameter to suppress shock given to the machine if the gain difference is large at gain switching, for example.

7. SPECIAL ADJUSTMENT FUNCTIONS

(2) Switchable gain parameter

| Loop gain | Before switching | | | After switching | | |
|---------------------------------------------------------------|------------------|--------|---------------------------------------------------------------|-----------------|--------|------------------------------------------------------------------------------------|
| | Parameter | Symbol | Name | Parameter | Symbol | Name |
| Load to motor inertia ratio/load to motor mass ratio | PB06 | GD2 | Load to motor inertia ratio/load to motor mass ratio | PB29 | GD2B | Load to motor inertia ratio/load to motor mass ratio after gain switching |
| Model loop gain | PB07 | PG1 | Model loop gain | PB60 | PG1B | Model loop gain after gain switching |
| Position loop gain | PB08 | PG2 | Position loop gain | PB30 | PG2B | Position loop gain after gain switching |
| Speed loop gain | PB09 | VG2 | Speed loop gain | PB31 | VG2B | Speed loop gain after gain switching |
| Speed integral compensation | PB10 | VIC | Speed integral compensation | PB32 | VICB | Speed integral compensation after gain switching |
| Vibration suppression control 1 - Vibration frequency | PB19 | VRF11 | Vibration suppression control 1 - Vibration frequency | PB33 | VRF11B | Vibration suppression control 1 - Vibration frequency after gain switching |
| Vibration suppression control 1 - Resonance frequency | PB20 | VRF12 | Vibration suppression control 1 - Resonance frequency | PB34 | VRF12B | Vibration suppression control 1 - Resonance frequency after gain switching |
| Vibration suppression control 1 - Vibration frequency damping | PB21 | VRF13 | Vibration suppression control 1 - Vibration frequency damping | PB35 | VRF13B | Vibration suppression control 1 - Vibration frequency damping after gain switching |
| Vibration suppression control 1 - Resonance frequency damping | PB22 | VRF14 | Vibration suppression control 1 - Resonance frequency damping | PB36 | VRF14B | Vibration suppression control 1 - Resonance frequency damping after gain switching |
| Vibration suppression control 2 - Vibration frequency | PB52 | VRF21 | Vibration suppression control 2 - Vibration frequency | PB56 | VRF21B | Vibration suppression control 2 - Vibration frequency after gain switching |
| Vibration suppression control 2 - Resonance frequency | PB53 | VRF22 | Vibration suppression control 2 - Resonance frequency | PB57 | VRF22B | Vibration suppression control 2 - Resonance frequency after gain switching |
| Vibration suppression control 2 - Vibration frequency damping | PB54 | VRF23 | Vibration suppression control 2 - Vibration frequency damping | PB58 | VRF23B | Vibration suppression control 2 - Vibration frequency damping after gain switching |
| Vibration suppression control 2 - Resonance frequency damping | PB55 | VRF24 | Vibration suppression control 2 - Resonance frequency damping | PB59 | VRF24B | Vibration suppression control 2 - Resonance frequency damping after gain switching |

(a) [Pr. PB06] to [Pr. PB10]

These parameters are the same as in ordinary manual adjustment. Gain switching allows the values of load to motor inertia ratio/load to motor mass ratio, position loop gain, model loop gain, speed loop gain, and speed integral compensation to be switched.

(b) [Pr. PB19] to [Pr. PB22]/[Pr. PB52] to [Pr. PB55]

These parameters are the same as in ordinary manual adjustment. Executing gain switching while the servo motor stops, You can change vibration frequency, resonance frequency, vibration frequency damping, and resonance frequency damping.

7. SPECIAL ADJUSTMENT FUNCTIONS

- (c) [Pr. PB29 Load to motor inertia ratio/load to motor mass ratio after gain switching]
Set the load to motor inertia ratio or load to motor mass ratio after gain switching. If the load to motor inertia ratio does not change, set it to the same value as [Pr. PB06 Load to motor inertia ratio/load to motor mass ratio].
- (d) [Pr. PB30 Position loop gain after gain switching], [Pr. PB31 Speed loop gain after gain switching], and [Pr. PB32 Speed integral compensation after gain switching]
Set the values of after switching position loop gain, speed loop gain and speed integral compensation.
- (e) Vibration suppression control after gain switching ([Pr. PB33] to [Pr. PB36]/[Pr. PB56] to [Pr. PB59]), and [Pr. PB60 Model loop gain after gain switching]
The gain switching vibration suppression control and gain switching model loop gain are used only with control command from the controller.
You can switch the vibration frequency, resonance frequency, vibration frequency damping, resonance frequency damping, and model loop gain of the vibration suppression control 1 and vibration suppression control 2.

7. SPECIAL ADJUSTMENT FUNCTIONS

7.2.4 Gain switching procedure

This operation will be described by way of setting examples.

(1) When you choose switching by control command from the controller

(a) Setting example

| Parameter | Symbol | Name | Setting value | Unit |
|-----------|--------|------------------------------------------------------------------------------------|----------------------------------------------------------|--------------|
| PB06 | GD2 | Load to motor inertia ratio/load to motor mass ratio | 4.00 | [Multiplier] |
| PB07 | PG1 | Model loop gain | 100 | [rad/s] |
| PB08 | PG2 | Position loop gain | 120 | [rad/s] |
| PB09 | VG2 | Speed loop gain | 3000 | [rad/s] |
| PB10 | VIC | Speed integral compensation | 20 | [ms] |
| PB19 | VRF11 | Vibration suppression control 1 - Vibration frequency | 50 | [Hz] |
| PB20 | VRF12 | Vibration suppression control 1 - Resonance frequency | 50 | [Hz] |
| PB21 | VRF13 | Vibration suppression control 1 - Vibration frequency damping | 0.20 | |
| PB22 | VRF14 | Vibration suppression control 1 - Resonance frequency damping | 0.20 | |
| PB52 | VRF21 | Vibration suppression control 2 - Vibration frequency | 20 | [Hz] |
| PB53 | VRF22 | Vibration suppression control 2 - Resonance frequency | 20 | [Hz] |
| PB54 | VRF23 | Vibration suppression control 2 - Vibration frequency damping | 0.10 | |
| PB55 | VRF24 | Vibration suppression control 2 - Resonance frequency damping | 0.10 | |
| PB29 | GD2B | Load to motor inertia ratio/load to motor mass ratio after gain switching | 10.00 | [Multiplier] |
| PB60 | PG1B | Model loop gain after gain switching | 50 | [rad/s] |
| PB30 | PG2B | Position loop gain after gain switching | 84 | [rad/s] |
| PB31 | VG2B | Speed loop gain after gain switching | 4000 | [rad/s] |
| PB32 | VICB | Speed integral compensation after gain switching | 50 | [ms] |
| PB26 | CDP | Gain switching function | 0001 (Switch by control command from the controller.) | |
| PB28 | CDT | Gain switching time constant | 100 | [ms] |
| PB33 | VRF11B | Vibration suppression control 1 - Vibration frequency after gain switching | 60 | [Hz] |
| PB34 | VRF12B | Vibration suppression control 1 - Resonance frequency after gain switching | 60 | [Hz] |
| PB35 | VRF13B | Vibration suppression control 1 - Vibration frequency damping after gain switching | 0.15 | |
| PB36 | VRF14B | Vibration suppression control 1 - Resonance frequency damping after gain switching | 0.15 | |
| PB56 | VRF21B | Vibration suppression control 2 - Vibration frequency after gain switching | 30 | [Hz] |
| PB57 | VRF22B | Vibration suppression control 2 - Resonance frequency after gain switching | 30 | [Hz] |
| PB58 | VRF23B | Vibration suppression control 2 - Vibration frequency damping after gain switching | 0.05 | |
| PB59 | VRF24B | Vibration suppression control 2 - Resonance frequency damping after gain switching | 0.05 | |

7. SPECIAL ADJUSTMENT FUNCTIONS

(b) Switching timing chart

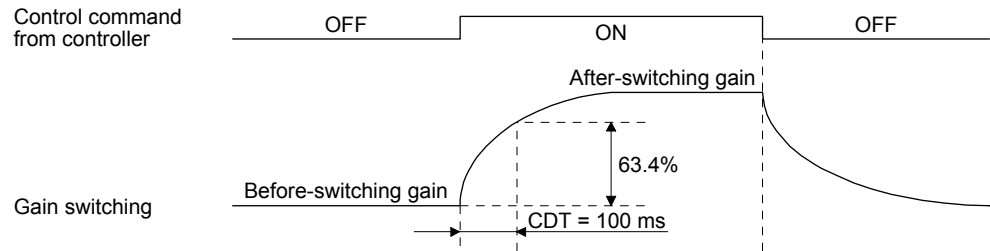

| | | | | | |
|---------------------------------------------------------------|------|---|-------|---|------|
| Model loop gain | 100 | → | 50 | → | 100 |
| Load to motor inertia ratio/load to motor mass ratio | 4.00 | → | 10.00 | → | 4.00 |
| Position loop gain | 120 | → | 84 | → | 120 |
| Speed loop gain | 3000 | → | 4000 | → | 3000 |
| Speed integral compensation | 20 | → | 50 | → | 20 |
| Vibration suppression control 1 - Vibration frequency | 50 | → | 60 | → | 50 |
| Vibration suppression control 1 - Resonance frequency | 50 | → | 60 | → | 50 |
| Vibration suppression control 1 - Vibration frequency damping | 0.20 | → | 0.15 | → | 0.20 |
| Vibration suppression control 1 - Resonance frequency damping | 0.20 | → | 0.15 | → | 0.20 |
| Vibration suppression control 2 - Vibration frequency | 20 | → | 30 | → | 20 |
| Vibration suppression control 2 - Resonance frequency | 20 | → | 30 | → | 20 |
| Vibration suppression control 2 - Vibration frequency damping | 0.10 | → | 0.05 | → | 0.10 |
| Vibration suppression control 2 - Resonance frequency damping | 0.10 | → | 0.05 | → | 0.10 |

(2) When you choose switching by droop pulses

The vibration suppression control after gain switching and model loop gain after gain switching cannot be used.

(a) Setting example

| Parameter | Symbol | Name | Setting value | Unit |
|-----------|--------|---------------------------------------------------------------------------|-------------------------------------|--------------|
| PB06 | GD2 | Load to motor inertia ratio/load to motor mass ratio | 4.00 | [Multiplier] |
| PB08 | PG2 | Position loop gain | 120 | [rad/s] |
| PB09 | VG2 | Speed loop gain | 3000 | [rad/s] |
| PB10 | VIC | Speed integral compensation | 20 | [ms] |
| PB29 | GD2B | Load to motor inertia ratio/load to motor mass ratio after gain switching | 10.00 | [Multiplier] |
| PB30 | PG2B | Position loop gain after gain switching | 84 | [rad/s] |
| PB31 | VG2B | Speed loop gain after gain switching | 4000 | [rad/s] |
| PB32 | VICB | Speed integral compensation after gain switching | 50 | [ms] |
| PB26 | CDP | Gain switching selection | 0003 (switching by droop pulses) | |
| PB27 | CDL | Gain switching condition | 50 | [pulse] |
| PB28 | CDT | Gain switching time constant | 100 | [ms] |

7. SPECIAL ADJUSTMENT FUNCTIONS

(b) Switching timing chart

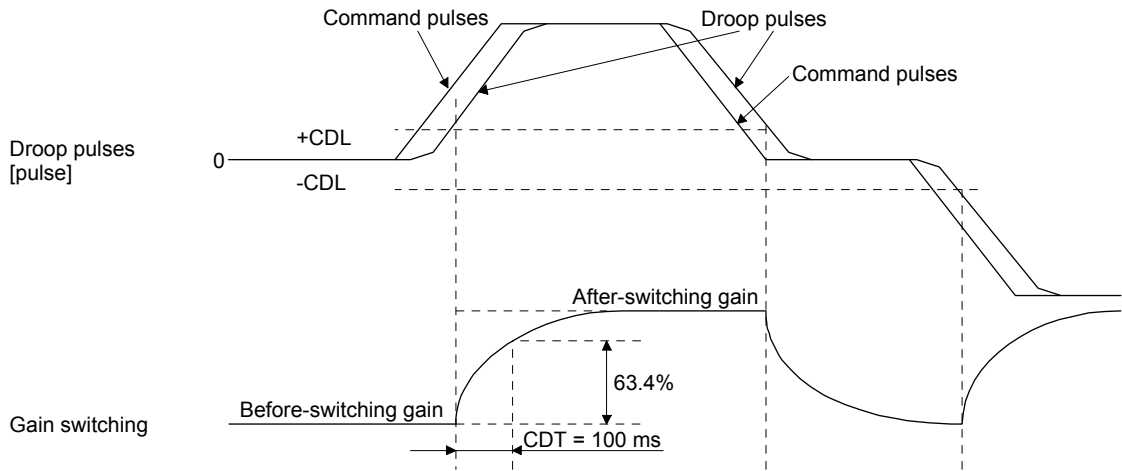

| | | | | | | | |
|------------------------------------------------------|------|---|-------|---|------|---|-------|
| Load to motor inertia ratio/load to motor mass ratio | 4.00 | → | 10.00 | → | 4.00 | → | 10.00 |
| Position loop gain | 120 | → | 84 | → | 120 | → | 84 |
| Speed loop gain | 3000 | → | 4000 | → | 3000 | → | 4000 |
| Speed integral compensation | 20 | → | 50 | → | 20 | → | 50 |

(3) When the gain switching time constant is disabled

(a) Switching time constant disabled was selected.

The gain switching time constant is disabled. The time constant is enabled at gain return.

The following example shows for [Pr. PB26 (CDP)] = 0103, [Pr. PB27 (CDL)] = 100 [pulse], and [Pr. PB28 (CDT)] = 100 [ms].

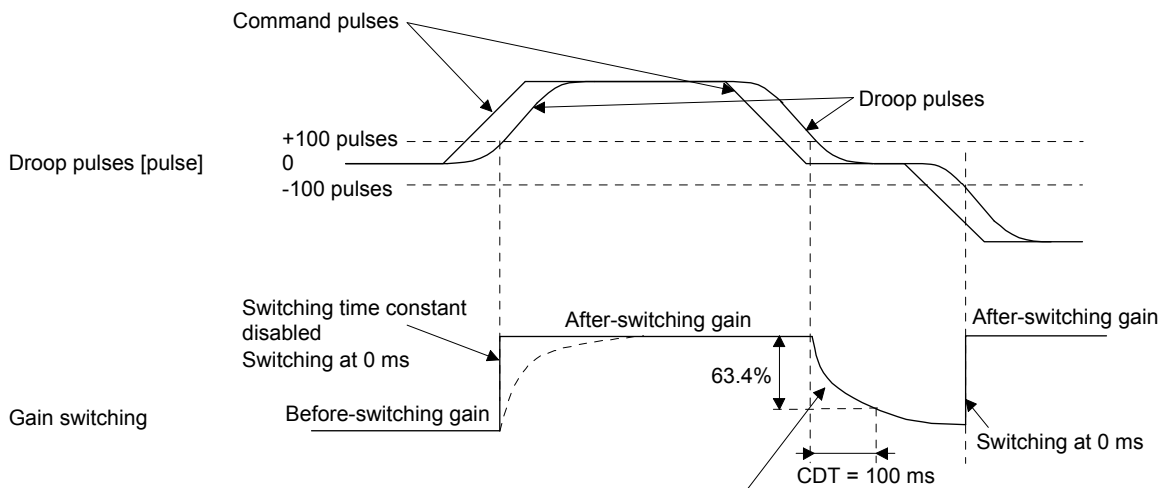

Switching at [Pr. PB28 (CDT)] = 100 [ms] only when gain switching off (when returning)

7. SPECIAL ADJUSTMENT FUNCTIONS

(b) Return time constant disabled was selected.

The gain switching time constant is enabled. The time constant is disabled at gain return.

The following example shows for [Pr. PB26 (CDP)] = 0201, [Pr. PB27 (CDL)] = 0, and [Pr. PB28 (CDT)] = 100 [ms].

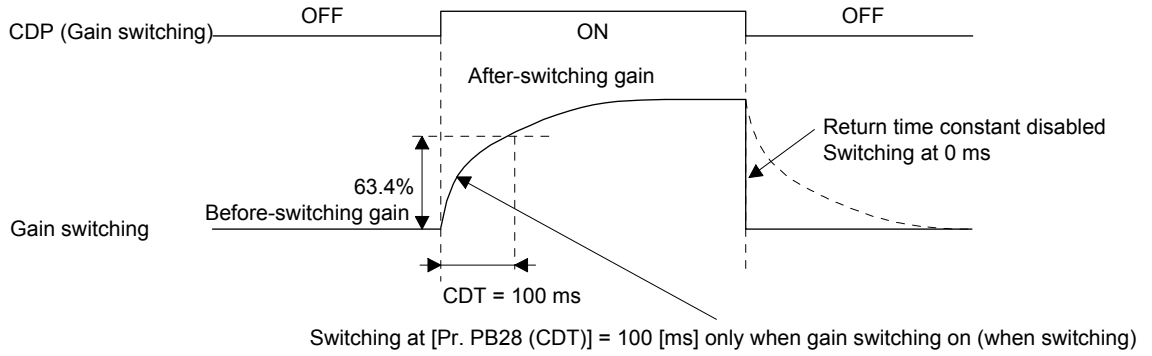

7. SPECIAL ADJUSTMENT FUNCTIONS

7.3 Tough drive function

| POINT |
|----------------------------------------------------------------------------------------------------------------|
| ●Set enable/disable of the tough drive function with [Pr. PA20 Tough drive setting]. (Refer to section 5.2.1.) |

This function makes the equipment continue operating even under the condition that an alarm occurs. The tough drive functions are the vibration tough drive and the instantaneous power failure tough drive.

7.3.1 Vibration tough drive function

This function prevents vibration by resetting a filter instantaneously when machine resonance occurs due to varied machine resonance frequency caused by machine aging.

To reset the machine resonance suppression filters with the function, [Pr. PB13 Machine resonance suppression filter 1] and [Pr. PB15 Machine resonance suppression filter 2] should be set in advance. Set [Pr. PB13] and [Pr. PB15] as follows.

(1) One-touch tuning execution (section 6.1)

(2) Manual setting (section 4.2.2)

The vibration tough drive function operates when a detected machine resonance frequency is within $\pm 30\%$ for a value set in [Pr. PB13 Machine resonance suppression filter 1] or [Pr. PB15 Machine resonance suppression filter 2].

To set a detection level of the function, set sensitivity in [Pr. PF23 Vibration tough drive - Oscillation detection level].

| POINT |
|-----------------------------------------------------------------------------------------------------------------------------------------------------------------------------------------------------------------|
| ●Resetting [Pr. PB13] and [Pr. PB15] by the vibration tough drive function is performed constantly. However, the number of write times to the EEPROM is limited to once per hour. |
| ●The vibration tough drive function does not reset [Pr. PB46 Machine resonance suppression filter 3], [Pr. PB48 Machine resonance suppression filter 4], and [Pr. PB50 Machine resonance suppression filter 5]. |
| ●The vibration tough drive function does not detect a vibration of 100 Hz or less. |

7. SPECIAL ADJUSTMENT FUNCTIONS

The following shows the function block diagram of the vibration tough drive function.

The function detects machine resonance frequency and compare it with [Pr. PB13] and [Pr. PB15], and reset a machine resonance frequency of a parameter whose set value is closer.

| Filter | Setting parameter | Precaution | Parameter that is reset with vibration tough drive function |
|----------------------------------------|-------------------|---------------------------------------------------------------------------------------------------------------------------------------------------------------------------------------------------------------------------------------------------------------------------------------------------------------------|-------------------------------------------------------------|
| Machine resonance suppression filter 1 | PB01/PB13/PB14 | The filter can be set automatically with "Filter tuning mode selection" in [Pr. PB01]. | PB13 |
| Machine resonance suppression filter 2 | PB15/PB16 | | PB15 |
| Machine resonance suppression filter 3 | PB46/PB47 | | |
| Machine resonance suppression filter 4 | PB48/PB49 | Enabling the machine resonance suppression filter 4 disables the shaft resonance suppression filter. Using the shaft resonance suppression filter is recommended because it is adjusted properly depending on the usage situation. The shaft resonance suppression filter is enabled for the initial setting. | |
| Machine resonance suppression filter 5 | PB50/PB51 | Enabling the robust filter disables the machine resonance suppression filter 5. The robust filter is disabled for the initial setting. | |

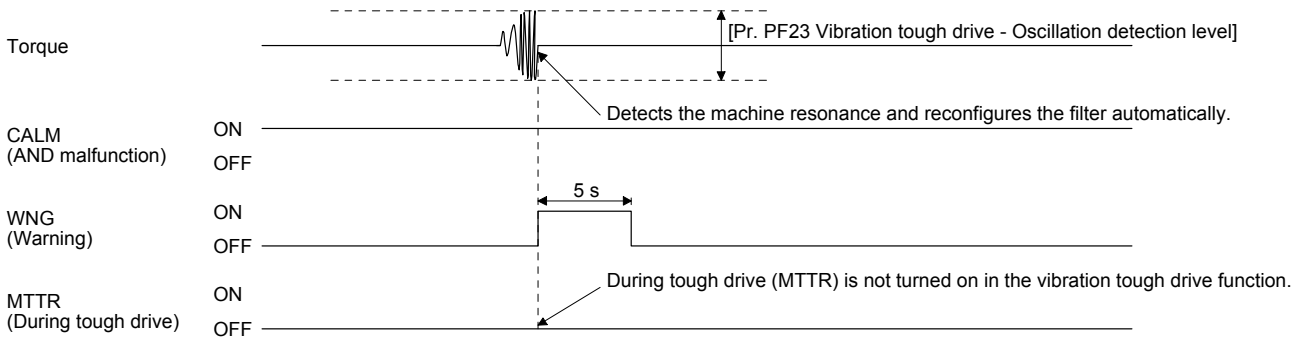
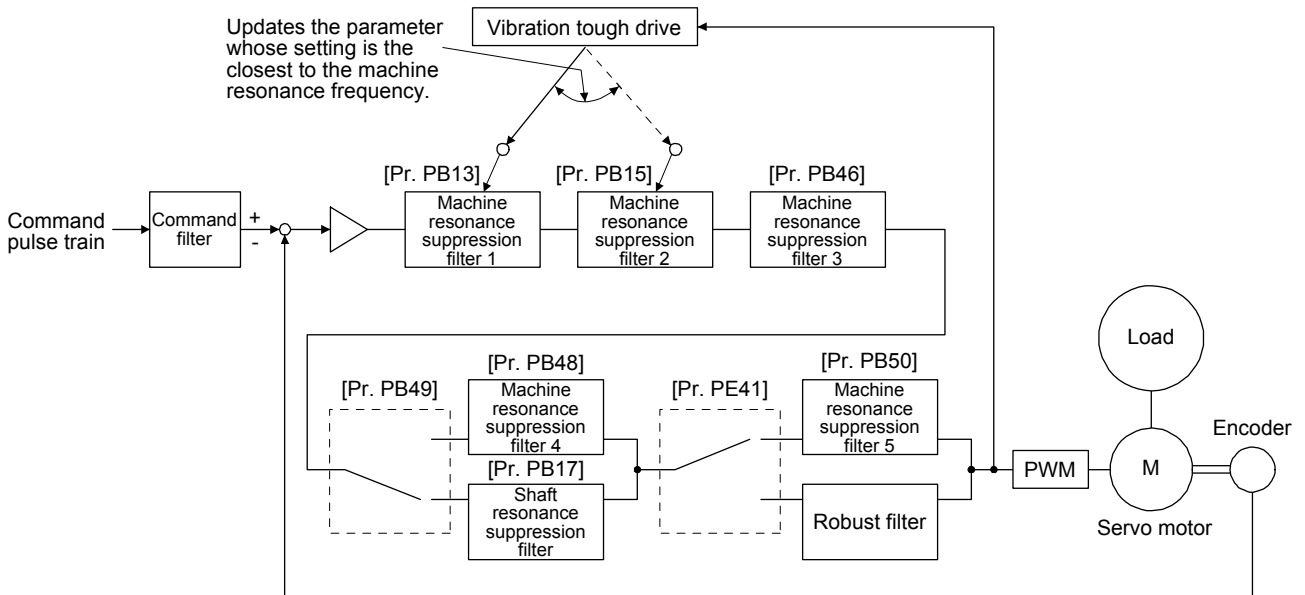

7. SPECIAL ADJUSTMENT FUNCTIONS

7.3.2 Instantaneous power failure tough drive function

The instantaneous power failure tough drive function avoids [AL. 10 Undervoltage] even when an instantaneous power failure occurs during operation. When the instantaneous power failure tough drive activates, the function will increase the tolerance against instantaneous power failures using the electrical energy charged in the capacitor in the servo amplifier and will change an alarm level of [AL. 10 Undervoltage] simultaneously. The [AL. 10.1 Voltage drop in the control circuit power] detection time for the control circuit power supply can be changed by [Pr. PF25 SEMI-F47 function - Instantaneous power failure detection time]. In addition, [AL. 10.2 Voltage drop in the main circuit power] detection level for the bus voltage is changed automatically.

| POINT |
|----------------------------------------------------------------------------------------------------------------------------------------------------------------------------------------------------------------------------------------------------------------------------------------------------------------------------------------------------------------------------------------------------------------------------------------------------------------------------------------------------------------------------------------------------------------------------------------------------------------------------------------------------------------------------------------------------------------------------------------------------------------------------------------------------------------------------------------------------------------------------------------------------------------------------------------------------------------------------------------------------------------------------------------------------------------------------------------------------------------------------------------------------------------------------------------------------------------------------------------------------|
| <ul style="list-style-type: none">● MBR (Electromagnetic brake interlock) will not turn off during the instantaneous power failure tough drive.● When the load of instantaneous power failure is large, [AL. 10.2] caused by the bus voltage drop may occur regardless of the set value of [Pr. PF25 SEMI-F47 function - Instantaneous power failure detection time].● MR-J4W2-0303B6 servo amplifier is not compatible with instantaneous power failure tough drive.● The setting range of [Pr. PF25 SEMI-F47 function - Instantaneous power failure detection time] differs depending on the software version of the servo amplifier as follows.<ul style="list-style-type: none">▪ Software version C0 or later: Setting range 30 ms to 200 ms▪ Software version C1 or earlier: Setting range 30 ms to 500 ms <p>To comply with SEMI-F47 standard, it is unnecessary to change the initial value (200 ms). However, when the instantaneous power failure time exceeds 200 ms, and the instantaneous power failure voltage is less than 70% of the rated input voltage, the power may be normally turned off even if a value larger than 200 ms is set in the parameter.</p> |

7. SPECIAL ADJUSTMENT FUNCTIONS

- (1) Instantaneous power failure time of the control circuit power supply > [Pr. PF25 SEMI-F47 function - Instantaneous power failure detection time]

The alarm occurs when the instantaneous power failure time of the control circuit power supply exceeds [Pr. PF25 SEMI-F47 function - Instantaneous power failure detection time].

MTTR (During tough drive) turns on after detecting the instantaneous power failure.

MBR (Electromagnetic brake interlock) turns off when the alarm occurs.

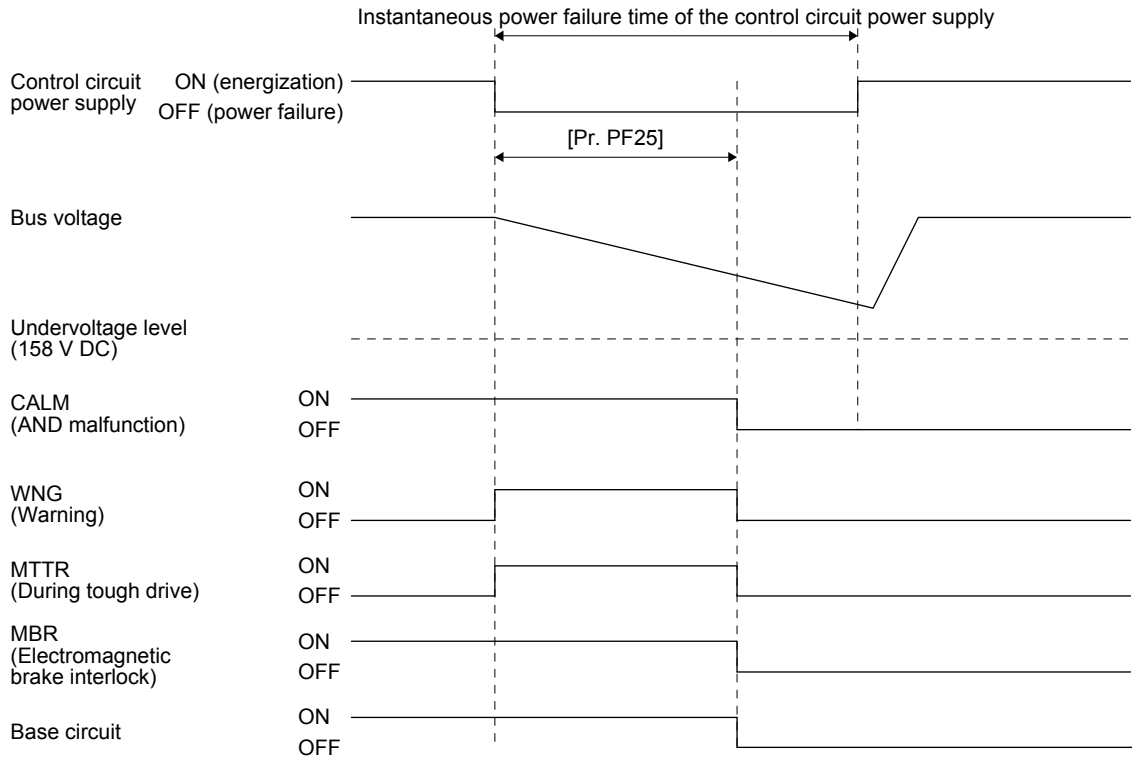

7. SPECIAL ADJUSTMENT FUNCTIONS

- (2) Instantaneous power failure time of the control circuit power supply < [Pr. PF25 SEMI-F47 function - Instantaneous power failure detection time]

Operation status differs depending on how bus voltage decrease.

- (a) When the bus voltage decrease lower than 158 V DC within the instantaneous power failure time of the control circuit power supply [AL. 10 Undervoltage] occurs when the bus voltage decrease lower than 158 V DC regardless of the enabled instantaneous power failure tough drive.

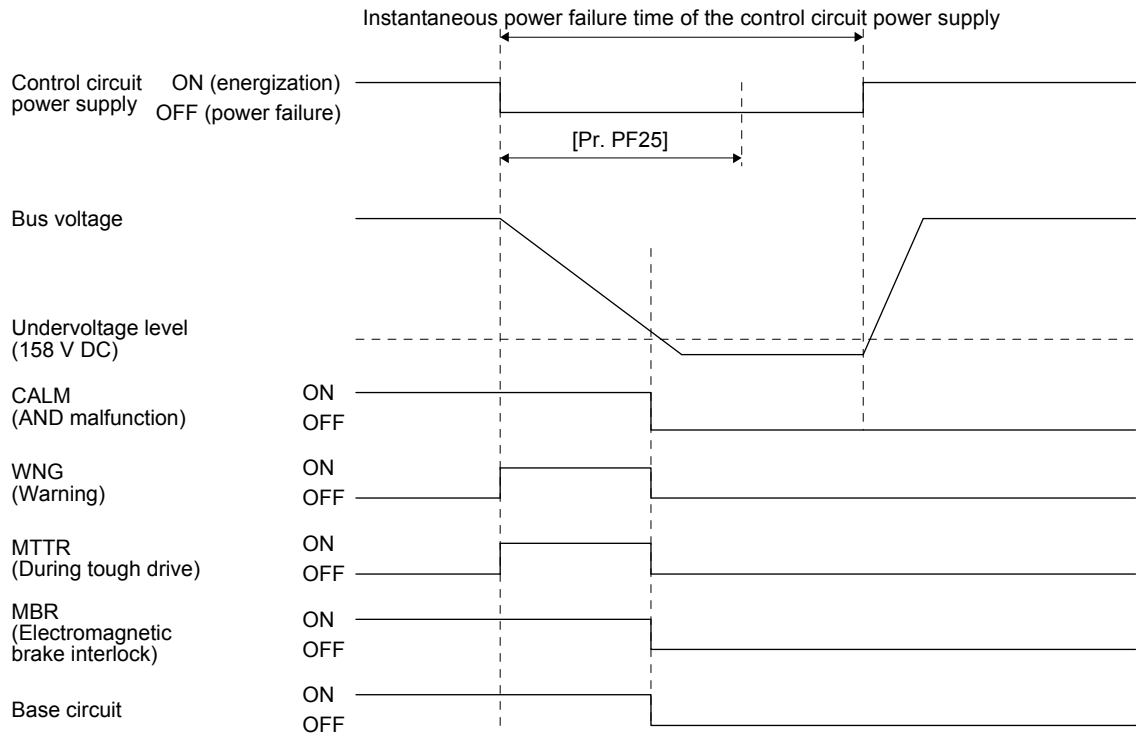

7. SPECIAL ADJUSTMENT FUNCTIONS

- (b) When the bus voltage does not decrease lower than 158 V DC within the instantaneous power failure time of the control circuit power supply
The operation continues without alarming.

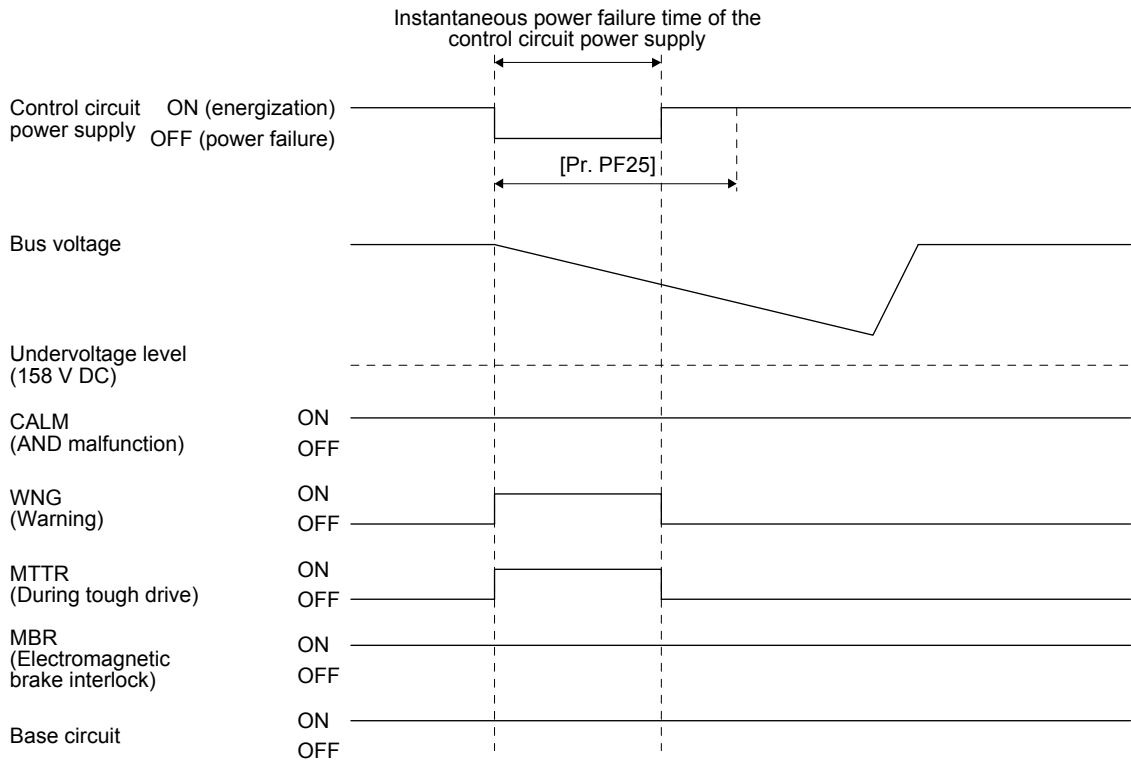

7. SPECIAL ADJUSTMENT FUNCTIONS

7.4 Compliance with SEMI-F47 standard

| POINT |
|------------------------------------------------------------------------------------------------------------------------------------------------------------------------------------------------------------------------------------------------------------------------------------------------------------------------------------------------------------------------------------------------------------------------------------------------------------------------------------------------------------------------------------------------------------------------------------------------------------------------------------------------------------------------------------------------------|
| <ul style="list-style-type: none"> ● The control circuit power supply of the MR-J4W_-_B 200 W or more servo amplifier can comply with SEMI-F47 standard. However, a back-up capacitor may be necessary for instantaneous power failure in the main circuit power supply depending on the power supply impedance and operating situation. Be sure to check them by testing the entire equipment using actual machines. ● Use a 3-phase for the input power supply of the servo amplifier. Using a 1-phase 200 V AC for the input power supply will not comply with SEMI-F47 standard. ● The MR-J4W2-0303B6 servo amplifier is not compatible with SEMI-F47 standard. |

The following explains the compliance with "SEMI-F47 semiconductor process equipment voltage sag immunity test" of MR-J4 series.

This function enables to avoid triggering [AL. 10 Undervoltage] using the electrical energy charged in the capacitor in case that an instantaneous power failure occurs during operation.

(1) Parameter setting

Setting [Pr. PA20] and [Pr. PF25] as follows will enable SEMI-F47 function.

| Parameter | Setting value | Description |
|-----------|---------------|-------------------------------------------------------------------------------------------|
| PA20 | _ 1 _ _ | Enable SEMI-F47 function selection. |
| PF25 | 200 | Set the time [ms] of the [AL. 10.1 Voltage drop in the control circuit power] occurrence. |

Enabling SEMI-F47 function will change operation as follows.

- (a) The voltage will drop in the control circuit power at "Rated voltage × 50% or less". After 200 ms, [AL. 10.1 Voltage drop in the control circuit power] will occur.
- (b) [AL. 10.2 Voltage drop in the main circuit power] will occur with 158 V DC or less in bus voltage.
- (c) MBR (Electromagnetic brake interlock) will turn off when [AL. 10.1 Voltage drop in the control circuit power] occurs.

(2) Requirement of SEMI-F47 standard

Table 7.1 shows the permissible time of instantaneous power failure for instantaneous power failure of SEMI-F47 standard.

Table 7.1 Requirement of SEMI-F47 standard

| Instantaneous power failure voltage | Permissible time of instantaneous power failure [s] |
|-------------------------------------|-----------------------------------------------------|
| Rated voltage × 80% | 1 |
| Rated voltage × 70% | 0.5 |
| Rated voltage × 50% | 0.2 |

7. SPECIAL ADJUSTMENT FUNCTIONS

(3) Calculation of tolerance against instantaneous power failure

Table 7.2 shows tolerance against instantaneous power failure when instantaneous power failure voltage is "rated voltage × 50%" and instantaneous power failure time is 200 ms.

Table 7.2 Tolerance against instantaneous power failure
(instantaneous power failure voltage = rated voltage × 50%,
instantaneous power failure time = 200 ms)

| Servo amplifier | Instantaneous maximum output [W] | Tolerance against instantaneous power failure [W] (Voltage drop between lines) |
|-----------------|----------------------------------|-----------------------------------------------------------------------------------|
| MR-J4W2-22B | 1400 (700 × 2) | 790 |
| MR-J4W2-44B | 2800 (1400 × 2) | 1190 |
| MR-J4W2-77B | 5250 (2625 × 2) | 2300 |
| MR-J4W2-1010B | 6000 (3000 × 2) | 2400 |
| MR-J4W3-222B | 2100 (700 × 3) | 970 |
| MR-J4W3-444B | 4200 (1400 × 3) | 1700 |

Instantaneous maximum output means power which servo amplifier can output in maximum torque at rated speed. You can examine margins to compare the values of following conditions and instantaneous maximum output.

Even if driving at maximum torque with low speed in actual operation, the motor will not drive with the maximum output. This can be handled as a margin.

The following shows the conditions of tolerance against instantaneous power failure.

(a) Delta connection

For 3-phase (L1/L2/L3) delta connection, an instantaneous power failure will be applied to a voltage between lines (e.g. between L1 and L2) from three pairs of voltages between lines (between L1 and L2, L2 and L3, or L3 and L1).

(b) Star connection

For 3-phase (L1/L2/L3/neutral point N) star connection, an instantaneous power failure will be applied to a voltage between lines (e.g. between L1 and N) from six pairs of voltages between lines (between L1 and L2, L2 and L3, or L3 and L1) and between line and neutral point (between L1 and N, L2 and N, or L3 and N).

7. SPECIAL ADJUSTMENT FUNCTIONS

7.5 Model adaptive control disabled

| POINT |
|-----------------------------------------------------------------------------------------------------------------------------------------------------------------------------------------------------------------------------------------------------------------------------------------------------------------------------------------------------------------------------------------------------|
| <ul style="list-style-type: none"> ● Change the parameters while the servo motor stops. ● When setting auto tuning response ([Pr. PA09]), change the setting value one by one to adjust with checking operation status of the servo motor. ● This is used by servo amplifiers with software version B4 or later. Check the software version with MR Configurator2. |

(1) Summary

The servo amplifier has a model adaptive control. The servo amplifier has a virtual motor model and drives the servo motor following the output of the motor model in the model adaptive control. At model adaptive control disabled, the servo amplifier drives motor with PID control without using the model adaptive control.

The following parameters are available at model adaptive control disabled.

| Parameter | Symbol | Name |
|-----------|--------|-----------------------------|
| PB08 | PG2 | Position loop gain |
| PB09 | VG2 | Speed loop gain |
| PB10 | VIC | Speed integral compensation |

(2) Parameter setting

Set [Pr. PB25] to "___2".

(3) Restrictions

The following functions are not available at model adaptive control disabled.

| Function | Explanation |
|------------------------------------------------------------------------------------------------------------------------------------------------|--------------------------------------------------------------------------------------------------------------------------------------------------------------------------------------------------------------------------------------------------------------|
| Forced stop deceleration function ([Pr. PA04]) | Disabling the model adaptive control while the forced stop deceleration function is enabled, [AL. 37] will occur. The forced stop deceleration function is enabled at factory setting. Set [Pr. PA04] to "0__" (forced stop deceleration function disabled). |
| Vibration suppression control 1 ([Pr. PB02]/[Pr. PB19]/[Pr. PB20]) Vibration suppression control 2 ([Pr. PB02]/[Pr. PB52]/[Pr. PB53]) | The vibration suppression control uses the model adaptive control. Disabling the model adaptive control will also disable the vibration suppression control. |
| Overshoot amount compensation ([Pr. PB12]) | The overshoot amount compensation uses data used by the model adaptive control. Disabling the model adaptive control will also disable the overshoot amount compensation. |

8. TROUBLESHOOTING

8. TROUBLESHOOTING

| POINT | |
|-------|----------------------------------------------------------------------------------------------------------------------------------------------------------------------------------------------------------------------------------------------------------------------------------------------------------------------------------------------------------------------------------------------------------------------------------------------------------------------------------------------------------------------------------------------------------------|
| | <ul style="list-style-type: none"> ● Refer to "MELSERVO-J4 Servo Amplifier Instruction Manual (Troubleshooting)" for details of alarms and warnings. ● If an alarm which indicates each axis in the stop method column occurs, the axis without the alarm operates the servo motor as per normal. ● As soon as an alarm occurs, make the Servo-off status and interrupt the main circuit power. ● [AL. 37 Parameter error] and warnings (except [AL. F0 Tough drive warning]) are not recorded in the alarm history. |

When an error occurs during operation, the corresponding alarm or warning is displayed. When an alarm or warning is displayed, refer to "MELSERVO-J4 Servo Amplifier Instruction Manual (Troubleshooting)" to remove the failure. When an alarm occurs, ALM (Malfunction) will turn off.

8.1 Explanation for the lists

(1) No./Name/Detail No./Detail name

Indicates each No./Name/Detail No./Detail name of alarms or warnings.

(2) Processing system

Processing system of alarms is as follows.

Each axis: Alarm is detected for each axis.

Common: Alarm is detected as the whole servo amplifier.

(3) Stop system

This means target axis to stop when the alarm occurs.

Each axis: Only alarming axis will stop.

All axes: All axes will stop.

(4) Stop method

For the alarms and warnings in which "SD" is written in the stop method column, the servo motor stops with the dynamic brake after forced stop deceleration. For the alarms and warnings in which "DB" or "EDB" is written in the stop method column, the servo motor stops with the dynamic brake without forced stop deceleration.

(5) Alarm deactivation

After the cause of the alarm has been removed, the alarm can be deactivated by any of the methods marked ○ in the alarm deactivation column. Warnings are automatically canceled after the cause of occurrence is removed. Alarms are deactivated with alarm reset, CPU reset, or cycling the power.

| Alarm deactivation | Explanation |
|--------------------|--------------------------------------------------------------------------------------------------------------------------------|
| Alarm reset | 1. Error reset command from controller 2. Pushing "Occurring Alarm Reset" in the "Alarm Display" window of MR Configurator2 |
| CPU reset | Resetting the controller itself |
| Cycling the power | Turning the power off and then turning it on again. |

8. TROUBLESHOOTING

8.2 Alarm list

| | No. | Name | Detail No. | Detail name | Stop method (Note 2, 3) | Alarm deactivation | | | Processing system (Note 8) | Stop system (Note 8) |
|-------|-----|---------------------------------------|-------------------------------------------------|---------------------------------------------------------------|-------------------------|--------------------|-----------|-------------------|----------------------------|----------------------|
| | | | | | | Alarm reset | CPU reset | Cycling the power | | |
| Alarm | 10 | Undervoltage | 10.1 | Voltage drop in the control circuit power | EDB | ○ | ○ | ○ | Common | All axes |
| | | | 10.2 | Voltage drop in the main circuit power | SD | ○ | ○ | ○ | Common | All axes |
| | 11 | Switch setting error | 11.1 | Axis number setting error/ Station number setting error | DB | △ | △ | ○ | Common | All axes |
| | | | 11.2 | Disabling control axis setting error | DB | △ | △ | ○ | Common | All axes |
| | 12 | Memory error 1 (RAM) | 12.1 | RAM error 1 | DB | △ | △ | ○ | Common | All axes |
| | | | 12.2 | RAM error 2 | DB | △ | △ | ○ | Common | All axes |
| | | | 12.3 | RAM error 3 | DB | △ | △ | ○ | Common | All axes |
| | | | 12.4 | RAM error 4 | DB | △ | △ | ○ | Common | All axes |
| | | | 12.5 | RAM error 5 | DB | △ | △ | ○ | Common | All axes |
| | | | 12.6 | RAM error 6 | DB | △ | △ | ○ | Common | All axes |
| | 13 | Clock error | 13.1 | Clock error 1 | DB | △ | △ | ○ | Common | All axes |
| | | | 13.2 | Clock error 2 | DB | △ | △ | ○ | Common | All axes |
| | 14 | Control process error | 14.1 | Control process error 1 | DB | △ | △ | ○ | Common | All axes |
| | | | 14.2 | Control process error 2 | DB | △ | △ | ○ | Common | All axes |
| | | | 14.3 | Control process error 3 | DB | △ | △ | ○ | Common | All axes |
| | | | 14.4 | Control process error 4 | DB | △ | △ | ○ | Common | All axes |
| | | | 14.5 | Control process error 5 | DB | △ | △ | ○ | Common | All axes |
| | | | 14.6 | Control process error 6 | DB | △ | △ | ○ | Common | All axes |
| | | | 14.7 | Control process error 7 | DB | △ | △ | ○ | Common | All axes |
| | | | 14.8 | Control process error 8 | DB | △ | △ | ○ | Common | All axes |
| | | | 14.9 | Control process error 9 | DB | △ | △ | ○ | Common | All axes |
| | | | 14.A | Control process error 10 | DB | △ | △ | ○ | Common | All axes |
| | | | 14.B | Control process error 11 | DB | △ | △ | ○ | Common | All axes |
| | 15 | Memory error 2 (EEP-ROM) | 15.1 | EEP-ROM error at power on | DB | △ | △ | ○ | Common | All axes |
| | | | 15.2 | EEP-ROM error during operation | DB | △ | △ | ○ | Common | All axes |
| | | | 15.4 | Home position information read error | DB | △ | △ | ○ | Common | All axes |
| | 16 | Encoder initial communication error 1 | 16.1 | Encoder initial communication - Receive data error 1 | DB | △ | △ | ○ | Each axis | Each axis |
| | | | 16.2 | Encoder initial communication - Receive data error 2 | DB | △ | △ | ○ | Each axis | Each axis |
| | | | 16.3 | Encoder initial communication - Receive data error 3 | DB | △ | △ | ○ | Each axis | Each axis |
| | | | 16.4 | Encoder initial communication - Encoder malfunction (Note 6) | DB | △ | △ | ○ | Each axis | Each axis |
| | | | 16.5 | Encoder initial communication - Transmission data error 1 | DB | △ | △ | ○ | Each axis | Each axis |
| | | | 16.6 | Encoder initial communication - Transmission data error 2 | DB | △ | △ | ○ | Each axis | Each axis |
| | | | 16.7 | Encoder initial communication - Transmission data error 3 | DB | △ | △ | ○ | Each axis | Each axis |
| | | | 16.8 | Encoder initial communication - Incompatible encoder (Note 6) | DB | △ | △ | ○ | Each axis | Each axis |
| | | | 16.A | Encoder initial communication - Process error 1 | DB | △ | △ | ○ | Each axis | Each axis |
| | | | 16.B | Encoder initial communication - Process error 2 | DB | △ | △ | ○ | Each axis | Each axis |
| 16.C | | | Encoder initial communication - Process error 3 | DB | △ | △ | ○ | Each axis | Each axis | |
| 16.D | | | Encoder initial communication - Process error 4 | DB | △ | △ | ○ | Each axis | Each axis | |
| 16.E | | | Encoder initial communication - Process error 5 | DB | △ | △ | ○ | Each axis | Each axis | |
| 16.F | | | Encoder initial communication - Process error 6 | DB | △ | △ | ○ | Each axis | Each axis | |

8. TROUBLESHOOTING

| | No. | Name | Detail No. | Detail name | Stop method (Note 2, 3) | Alarm deactivation | | | Processing system (Note 8) | Stop system (Note 8) | |
|-------|--------------------------------------|---------------------------------------|----------------------------------------------------------|-----------------------------------------------------|-------------------------|--------------------|-----------|-------------------|----------------------------|----------------------|---|
| | | | | | | Alarm reset | CPU reset | Cycling the power | | | |
| Alarm | 17 | Board error | 17.1 | Board error 1 | DB | / | / | ○ | Common | All axes | |
| | | | 17.3 | Board error 2 | DB | / | / | ○ | Common | All axes | |
| | | | 17.4 | Board error 3 | DB | / | / | ○ | Common | All axes | |
| | | | 17.5 | Board error 4 | DB | / | / | ○ | Common | All axes | |
| | | | 17.6 | Board error 5 | DB | / | / | ○ | Common | All axes | |
| | | | 17.7 | Board error 7 | DB | / | / | ○ | / | / | |
| | | | 17.8 | Board error 6 (Note 6) | EDB | / | / | ○ | Common | All axes | |
| | | | | 17.9 | Board error 8 | DB | / | / | ○ | / | / |
| | 19 | Memory error 3 (Flash-ROM) | 19.1 | Flash-ROM error 1 | DB | / | / | ○ | Common | All axes | |
| | | | 19.2 | Flash-ROM error 2 | DB | / | / | ○ | Common | All axes | |
| | | | 19.3 | Flash-ROM error 3 | DB | / | / | ○ | / | / | |
| | 1A | Servo motor combination error | 1A.1 | Servo motor combination error 1 | DB | / | / | ○ | Each axis | Each axis | |
| | | | 1A.2 | Servo motor control mode combination error | DB | / | / | ○ | Each axis | Each axis | |
| | | | 1A.4 | Servo motor combination error 2 | DB | / | / | ○ | Each axis | Each axis | |
| | 1B | Converter error | 1B.1 | Converter unit error | DB | / | / | ○ | / | / | |
| | 1E | Encoder initial communication error 2 | 1E.1 | Encoder malfunction | DB | / | / | ○ | Each axis | Each axis | |
| | | | 1E.2 | Load-side encoder malfunction | DB | / | / | ○ | Each axis | Each axis | |
| | 1F | Encoder initial communication error 3 | 1F.1 | Incompatible encoder | DB | / | / | ○ | Each axis | Each axis | |
| | | | 1F.2 | Incompatible load-side encoder | DB | / | / | ○ | Each axis | Each axis | |
| | 20 | Encoder normal communication error 1 | 20.1 | Encoder normal communication - Receive data error 1 | EDB | / | / | ○ | Each axis | Each axis | |
| | | | 20.2 | Encoder normal communication - Receive data error 2 | EDB | / | / | ○ | Each axis | Each axis | |
| 20.3 | | | Encoder normal communication - Receive data error 3 | EDB | / | / | ○ | Each axis | Each axis | | |
| 20.5 | | | Encoder normal communication - Transmission data error 1 | EDB | / | / | ○ | Each axis | Each axis | | |
| 20.6 | | | Encoder normal communication - Transmission data error 2 | EDB | / | / | ○ | Each axis | Each axis | | |
| 20.7 | | | Encoder normal communication - Transmission data error 3 | EDB | / | / | ○ | Each axis | Each axis | | |
| 20.9 | | | Encoder normal communication - Receive data error 4 | EDB | / | / | ○ | Each axis | Each axis | | |
| 20.A | | | Encoder normal communication - Receive data error 5 | EDB | / | / | ○ | Each axis | Each axis | | |
| 21 | Encoder normal communication error 2 | 21.1 | Encoder data error 1 | EDB | / | / | ○ | Each axis | Each axis | | |
| | | 21.2 | Encoder data update error | EDB | / | / | ○ | Each axis | Each axis | | |
| | | 21.3 | Encoder data waveform error | EDB | / | / | ○ | Each axis | Each axis | | |
| | | 21.4 | Encoder non-signal error | EDB | / | / | ○ | Each axis | Each axis | | |
| | | 21.5 | Encoder hardware error 1 | EDB | / | / | ○ | Each axis | Each axis | | |
| | | 21.6 | Encoder hardware error 2 | EDB | / | / | ○ | Each axis | Each axis | | |
| | | 21.9 | Encoder data error 2 | EDB | / | / | ○ | Each axis | Each axis | | |

8. TROUBLESHOOTING

| | No. | Name | Detail No. | Detail name | Stop method (Note 2, 3) | Alarm deactivation | | | Processing system (Note 8) | Stop system (Note 8) |
|-------|------|---------------------------------------|------------|------------------------------------------------------------------------|-------------------------|--------------------------|------------|-------------------|----------------------------|----------------------|
| | | | | | | Alarm reset | CPU reset | Cycling the power | | |
| Alarm | 24 | Main circuit error | 24.1 | Ground fault detected by hardware detection circuit | DB | / | / | ○ | Each axis | All axes |
| | | | 24.2 | Ground fault detected by software detection function | DB | ○ | ○ | ○ | Each axis | All axes |
| | 25 | Absolute position erased | 25.1 | Servo motor encoder - Absolute position erased | DB | / | / | ○ | Each axis | Each axis |
| | | | 25.2 | Scale measurement encoder - Absolute position erased | DB | / | / | ○ | Each axis | Each axis |
| | 27 | Initial magnetic pole detection error | 27.1 | Initial magnetic pole detection - Abnormal termination | DB | ○ | / | ○ | Each axis | Each axis |
| | | | 27.2 | Initial magnetic pole detection - Time out error | DB | ○ | / | ○ | Each axis | Each axis |
| | | | 27.3 | Initial magnetic pole detection - Limit switch error | DB | ○ | / | ○ | Each axis | Each axis |
| | | | 27.4 | Initial magnetic pole detection - Estimated error | DB | ○ | / | ○ | Each axis | Each axis |
| | | | 27.5 | Initial magnetic pole detection - Position deviation error | DB | ○ | / | ○ | Each axis | Each axis |
| | | | 27.6 | Initial magnetic pole detection - Speed deviation error | DB | ○ | / | ○ | Each axis | Each axis |
| | 28 | Linear encoder error 2 | 28.1 | Linear encoder - Environment error | EDB | / | / | ○ | Each axis | Each axis |
| | | | 2A | Linear encoder error 1 | 2A.1 | Linear encoder error 1-1 | EDB | / | / | ○ |
| | 2A.2 | Linear encoder error 1-2 | | | EDB | / | / | ○ | Each axis | Each axis |
| | 2A.3 | Linear encoder error 1-3 | | | EDB | / | / | ○ | Each axis | Each axis |
| | 2A.4 | Linear encoder error 1-4 | | | EDB | / | / | ○ | Each axis | Each axis |
| | 2A.5 | Linear encoder error 1-5 | | | EDB | / | / | ○ | Each axis | Each axis |
| | 2A.6 | Linear encoder error 1-6 | | | EDB | / | / | ○ | Each axis | Each axis |
| | 2A.7 | Linear encoder error 1-7 | | | EDB | / | / | ○ | Each axis | Each axis |
| | 2A.8 | Linear encoder error 1-8 | | | EDB | / | / | ○ | Each axis | Each axis |
| | 2B | Encoder counter error | 2B.1 | Encoder counter error 1 | EDB | / | / | ○ | Each axis | Each axis |
| | | | 2B.2 | Encoder counter error 2 | EDB | / | / | ○ | Each axis | Each axis |
| | 30 | Regenerative error | 30.1 | Regeneration heat error | DB | ○ (Note 1) | ○ (Note 1) | ○ (Note 1) | Common | All axes |
| | | | 30.2 | Regeneration signal error | DB | ○ (Note 1) | ○ (Note 1) | ○ (Note 1) | Common | All axes |
| | | | 30.3 | Regeneration feedback signal error | DB | ○ (Note 1) | ○ (Note 1) | ○ (Note 1) | Common | All axes |
| | 31 | Overspeed | 31.1 | Abnormal motor speed | SD | ○ | ○ | ○ | Each axis | Each axis |
| | 32 | Overcurrent | 32.1 | Overcurrent detected at hardware detection circuit (during operation) | DB | / | / | ○ | Each axis | All axes |
| | | | 32.2 | Overcurrent detected at software detection function (during operation) | DB | ○ | ○ | ○ | Each axis | All axes |
| | | | 32.3 | Overcurrent detected at hardware detection circuit (during a stop) | DB | / | / | ○ | Each axis | All axes |
| | | | 32.4 | Overcurrent detected at software detection function (during a stop) | DB | ○ | ○ | ○ | Each axis | All axes |
| | 33 | Overvoltage | 33.1 | Main circuit voltage error | EDB | ○ | ○ | ○ | Common | All axes |

8. TROUBLESHOOTING

| | No. | Name | Detail No. | Detail name | Stop method (Note 2, 3) | Alarm deactivation | | | Processing system (Note 8) | Stop system (Note 8) |
|-------|------------------------------|---------------------------------------------------------------------|---------------------------------------------------------------------------|-------------------------------------------------------------------|-------------------------|--------------------|------------|-------------------|----------------------------|----------------------|
| | | | | | | Alarm reset | CPU reset | Cycling the power | | |
| Alarm | 34 | SSCNET receive error 1 | 34.1 | SSCNET receive data error | SD | ○ | ○ (Note 5) | ○ | Common | All axes |
| | | | 34.2 | SSCNET connector connection error | SD | ○ | ○ | ○ | Common | All axes |
| | | | 34.3 | SSCNET communication data error | SD | ○ | ○ | ○ | Each axis | Each axis |
| | | | 34.4 | Hardware error signal detection | SD | ○ | ○ | ○ | Common | All axes |
| | | | 34.5 | SSCNET receive data error (safety observation function) | SD | ○ | ○ | ○ | | |
| | | | 34.6 | SSCNET communication data error (safety observation function) | SD | ○ | ○ | ○ | | |
| | 35 | Command frequency error | 35.1 | Command frequency error | SD | ○ | ○ | ○ | Each axis | Each axis |
| | 36 | SSCNET receive error 2 | 36.1 | Continuous communication data error | SD | ○ | ○ | ○ | Each axis | Each axis |
| | | | 36.2 | Continuous communication data error (safety observation function) | SD | ○ | ○ | ○ | | |
| | 37 | Parameter error | 37.1 | Parameter setting range error | DB | | ○ | ○ | Each axis | Each axis |
| | | | 37.2 | Parameter combination error | DB | | ○ | ○ | Each axis | Each axis |
| | | | 37.3 | Point table setting error | DB | | | ○ | | |
| | 39 | Program error | 39.1 | Program error | DB | | | ○ | | |
| | | | 39.2 | Instruction argument external error | DB | | | ○ | | |
| | | | 39.3 | Register No. error | DB | | | ○ | | |
| | | | 39.4 | Non-correspondence instruction error | DB | | | ○ | | |
| | 3A | Inrush current suppression circuit error | 3A.1 | Inrush current suppression circuit error | EDB | | | ○ | Common | All axes |
| | 3D | Parameter setting error for driver communication | 3D.1 | Parameter combination error for driver communication on slave | DB | | | ○ | | |
| | | | 3D.2 | Parameter combination error for driver communication on master | DB | | | ○ | | |
| | 3E | Operation mode error | 3E.1 | Operation mode error | DB | | ○ | ○ | Each axis | Each axis |
| | | | 3E.6 | Operation mode switch error | DB | | | ○ | | |
| | 42 | Servo control error (for linear servo motor and direct drive motor) | 42.1 | Servo control error by position deviation | EDB | (Note 4) | (Note 4) | ○ | Each axis | Each axis |
| | | | 42.2 | Servo control error by speed deviation | EDB | (Note 4) | (Note 4) | ○ | Each axis | Each axis |
| | | | 42.3 | Servo control error by torque/thrust deviation | EDB | (Note 4) | (Note 4) | ○ | Each axis | Each axis |
| | | Fully closed loop control error (for fully closed loop control) | 42.8 | Fully closed loop control error by position deviation | EDB | (Note 4) | (Note 4) | ○ | Each axis | Each axis |
| | | | 42.9 | Fully closed loop control error by speed deviation | EDB | (Note 4) | (Note 4) | ○ | Each axis | Each axis |
| 42.A | | | Fully closed loop control error by position deviation during command stop | EDB | (Note 4) | (Note 4) | ○ | Each axis | Each axis | |
| 45 | Main circuit device overheat | 45.1 | Main circuit device overheat error 1 | SD | ○ (Note 1) | ○ (Note 1) | ○ (Note 1) | Common | All axes | |
| | | 45.2 | Main circuit device overheat error 2 | SD | ○ (Note 1) | ○ (Note 1) | ○ (Note 1) | Common | All axes | |

8. TROUBLESHOOTING

| | No. | Name | Detail No. | Detail name | Stop method (Note 2, 3) | Alarm deactivation | | | Processing system (Note 8) | Stop system (Note 8) |
|-------|-----|--------------------------------------|------------|--------------------------------------------|-------------------------|--------------------|---------------|-------------------|----------------------------|----------------------|
| | | | | | | Alarm reset | CPU reset | Cycling the power | | |
| Alarm | 46 | Servo motor overheat | 46.1 | Abnormal temperature of servo motor 1 | SD | ○ (Note 1) | ○ (Note 1) | ○ (Note 1) | Each axis | Each axis |
| | | | 46.2 | Abnormal temperature of servo motor 2 | SD | ○ (Note 1) | ○ (Note 1) | ○ (Note 1) | Each axis | Each axis |
| | | | 46.3 | Thermistor disconnected error | SD | ○ (Note 1) | ○ (Note 1) | ○ (Note 1) | Each axis | Each axis |
| | | | 46.4 | Thermistor circuit error | SD | ○ (Note 1) | ○ (Note 1) | ○ (Note 1) | Each axis | Each axis |
| | | | 46.5 | Abnormal temperature of servo motor 3 | DB | ○ (Note 1) | ○ (Note 1) | ○ (Note 1) | Each axis | Each axis |
| | | | 46.6 | Abnormal temperature of servo motor 4 | DB | ○ (Note 1) | ○ (Note 1) | ○ (Note 1) | Each axis | Each axis |
| | 47 | Cooling fan error | 47.1 | Cooling fan stop error | SD | △ | △ | ○ | Common | All axes |
| | | | 47.2 | Cooling fan speed reduction error | SD | △ | △ | ○ | Common | All axes |
| | 50 | Overload 1 | 50.1 | Thermal overload error 1 during operation | SD | ○ (Note 1) | ○ (Note 1) | ○ (Note 1) | Each axis | Each axis |
| | | | 50.2 | Thermal overload error 2 during operation | SD | ○ (Note 1) | ○ (Note 1) | ○ (Note 1) | Each axis | Each axis |
| | | | 50.3 | Thermal overload error 4 during operation | SD | ○ (Note 1) | ○ (Note 1) | ○ (Note 1) | Each axis | Each axis |
| | | | 50.4 | Thermal overload error 1 during a stop | SD | ○ (Note 1) | ○ (Note 1) | ○ (Note 1) | Each axis | Each axis |
| | | | 50.5 | Thermal overload error 2 during a stop | SD | ○ (Note 1) | ○ (Note 1) | ○ (Note 1) | Each axis | Each axis |
| | | | 50.6 | Thermal overload error 4 during a stop | SD | ○ (Note 1) | ○ (Note 1) | ○ (Note 1) | Each axis | Each axis |
| | 51 | Overload 2 | 51.1 | Thermal overload error 3 during operation | DB | ○ (Note 1) | ○ (Note 1) | ○ (Note 1) | Each axis | Each axis |
| | | | 51.2 | Thermal overload error 3 during a stop | DB | ○ (Note 1) | ○ (Note 1) | ○ (Note 1) | Each axis | Each axis |
| | 52 | Error excessive | 52.1 | Excess droop pulse 1 | SD | ○ | ○ | ○ | Each axis | Each axis |
| | | | 52.3 | Excess droop pulse 2 | SD | ○ | ○ | ○ | Each axis | Each axis |
| | | | 52.4 | Error excessive during 0 torque limit | SD | ○ | ○ | ○ | Each axis | Each axis |
| | | | 52.5 | Excess droop pulse 3 | EDB | ○ | ○ | ○ | Each axis | Each axis |
| | 54 | Oscillation detection | 54.1 | Oscillation detection error | EDB | ○ | ○ | ○ | Each axis | Each axis |
| | 56 | Forced stop error | 56.2 | Over speed during forced stop | EDB | ○ | ○ | ○ | Each axis | Each axis |
| | | | 56.3 | Estimated distance over during forced stop | EDB | ○ | ○ | ○ | Each axis | Each axis |
| | 61 | Operation error | 61.1 | Point table setting range error | DB | ○ | △ | ○ | △ | △ |
| | 63 | STO timing error | 63.1 | STO1 off | DB | ○ | ○ | ○ | Common | All axes |
| | | | 63.2 | STO2 off | DB | ○ | ○ | ○ | Common | All axes |
| | | | 63.5 | STO by functional safety unit | DB | ○ | ○ | ○ | △ | △ |
| | 64 | Functional safety unit setting error | 64.1 | STO input error | DB | △ | △ | ○ | △ | △ |
| | | | 64.2 | Compatibility mode setting error | DB | △ | △ | ○ | △ | △ |
| | | | 64.3 | Operation mode setting error | DB | △ | △ | ○ | △ | △ |

8. TROUBLESHOOTING

| | No. | Name | Detail No. | Detail name | Stop method (Note 2, 3) | Alarm deactivation | | | Processing system (Note 8) | Stop system (Note 8) |
|-------|-----|--------------------------------------------------------------------|------------|-----------------------------------------------------------------------------------------|-------------------------|--------------------|-----------|-------------------|----------------------------|----------------------|
| | | | | | | Alarm reset | CPU reset | Cycling the power | | |
| Alarm | 65 | Functional safety unit connection error | 65.1 | Functional safety unit communication error 1 | SD | / | / | ○ | / | / |
| | | | 65.2 | Functional safety unit communication error 2 | SD | / | / | ○ | / | / |
| | | | 65.3 | Functional safety unit communication error 3 | SD | / | / | ○ | / | / |
| | | | 65.4 | Functional safety unit communication error 4 | SD | / | / | ○ | / | / |
| | | | 65.5 | Functional safety unit communication error 5 | SD | / | / | ○ | / | / |
| | | | 65.6 | Functional safety unit communication error 6 | SD | / | / | ○ | / | / |
| | | | 65.7 | Functional safety unit communication error 7 | SD | / | / | ○ | / | / |
| | | | 65.8 | Functional safety unit shut-off signal error 1 | DB | / | / | ○ | / | / |
| | | | 65.9 | Functional safety unit shut-off signal error 2 | DB | / | / | ○ | / | / |
| | 66 | Encoder initial communication error (safety observation function) | 66.1 | Encoder initial communication - Receive data error 1 (safety observation function) | DB | / | / | ○ | / | / |
| | | | 66.2 | Encoder initial communication - Receive data error 2 (safety observation function) | DB | / | / | ○ | / | / |
| | | | 66.3 | Encoder initial communication - Receive data error 3 (safety observation function) | DB | / | / | ○ | / | / |
| | | | 66.7 | Encoder initial communication - Transmission data error 1 (safety observation function) | DB | / | / | ○ | / | / |
| | | | 66.9 | Encoder initial communication - Process error 1 (safety observation function) | DB | / | / | ○ | / | / |
| | 67 | Encoder normal communication error 1 (safety observation function) | 67.1 | Encoder normal communication - Receive data error 1 (safety observation function) | DB | / | / | ○ | / | / |
| | | | 67.2 | Encoder normal communication - Receive data error 2 (safety observation function) | DB | / | / | ○ | / | / |
| | | | 67.3 | Encoder normal communication - Receive data error 3 (safety observation function) | DB | / | / | ○ | / | / |
| | | | 67.4 | Encoder normal communication - Receive data error 4 (safety observation function) | DB | / | / | ○ | / | / |
| | | | 67.7 | Encoder normal communication - Transmission data error 1 (safety observation function) | DB | / | / | ○ | / | / |
| | 68 | STO diagnosis error | 68.1 | Mismatched STO signal error | DB | / | / | ○ | Common | Common |
| | 69 | Command error | 69.1 | Forward rotation-side software limit detection - Command excess error | SD | ○ | ○ | ○ | / | / |
| | | | 69.2 | Reverse rotation-side software limit detection - Command excess error | SD | ○ | ○ | ○ | / | / |
| | | | 69.3 | Forward rotation stroke end detection - Command excess error | SD | ○ | ○ | ○ | / | / |
| | | | 69.4 | Reverse rotation stroke end detection - Command excess error | SD | ○ | ○ | ○ | / | / |
| | | | 69.5 | Upper stroke limit detection - Command excess error | SD | ○ | ○ | ○ | / | / |
| | | | 69.6 | Lower stroke limit detection - Command excess error | SD | ○ | ○ | ○ | / | / |

8. TROUBLESHOOTING

| | No. | Name | Detail No. | Detail name | Stop method (Note 2, 3) | Alarm deactivation | | | Processing system (Note 8) | Stop system (Note 8) |
|-------|-----|-------------------------------------------------|---------------------------------------------------------------|-------------------------------------------------------------------------|-------------------------|--------------------|-----------|-------------------|----------------------------|----------------------|
| | | | | | | Alarm reset | CPU reset | Cycling the power | | |
| Alarm | 70 | Load-side encoder initial communication error 1 | 70.1 | Load-side encoder initial communication - Receive data error 1 | DB | / | / | ○ | Each axis | Each axis |
| | | | 70.2 | Load-side encoder initial communication - Receive data error 2 | DB | / | / | ○ | Each axis | Each axis |
| | | | 70.3 | Load-side encoder initial communication - Receive data error 3 | DB | / | / | ○ | Each axis | Each axis |
| | | | 70.4 | Load-side encoder initial communication - Encoder malfunction (Note 6) | DB | / | / | ○ | Each axis | Each axis |
| | | | 70.5 | Load-side encoder initial communication - Transmission data error 1 | DB | / | / | ○ | Each axis | Each axis |
| | | | 70.6 | Load-side encoder initial communication - Transmission data error 2 | DB | / | / | ○ | Each axis | Each axis |
| | | | 70.7 | Load-side encoder initial communication - Transmission data error 3 | DB | / | / | ○ | Each axis | Each axis |
| | | | 70.8 | Load-side encoder initial communication - Incompatible encoder (Note 6) | DB | / | / | ○ | Each axis | Each axis |
| | | | 70.A | Load-side encoder initial communication - Process error 1 | DB | / | / | ○ | Each axis | Each axis |
| | | | 70.B | Load-side encoder initial communication - Process error 2 | DB | / | / | ○ | Each axis | Each axis |
| | | | 70.C | Load-side encoder initial communication - Process error 3 | DB | / | / | ○ | Each axis | Each axis |
| | | | 70.D | Load-side encoder initial communication - Process error 4 | DB | / | / | ○ | Each axis | Each axis |
| | | | 70.E | Load-side encoder initial communication - Process error 5 | DB | / | / | ○ | Each axis | Each axis |
| | | | 70.F | Load-side encoder initial communication - Process error 6 | DB | / | / | ○ | Each axis | Each axis |
| | 71 | Load-side encoder normal communication error 1 | 71.1 | Load-side encoder normal communication - Receive data error 1 | EDB | / | / | ○ | Each axis | Each axis |
| | | | 71.2 | Load-side encoder normal communication - Receive data error 2 | EDB | / | / | ○ | Each axis | Each axis |
| | | | 71.3 | Load-side encoder normal communication - Receive data error 3 | EDB | / | / | ○ | Each axis | Each axis |
| | | | 71.5 | Load-side encoder normal communication - Transmission data error 1 | EDB | / | / | ○ | Each axis | Each axis |
| | | | 71.6 | Load-side encoder normal communication - Transmission data error 2 | EDB | / | / | ○ | Each axis | Each axis |
| | | | 71.7 | Load-side encoder normal communication - Transmission data error 3 | EDB | / | / | ○ | Each axis | Each axis |
| 71.9 | | | Load-side encoder normal communication - Receive data error 4 | EDB | / | / | ○ | Each axis | Each axis | |
| 71.A | | | Load-side encoder normal communication - Receive data error 5 | EDB | / | / | ○ | Each axis | Each axis | |

8. TROUBLESHOOTING

| | No. | Name | Detail No. | Detail name | Stop method (Note 2, 3) | Alarm deactivation | | | Processing system (Note 8) | Stop system (Note 8) |
|-------|------------------------------------------------------------------------------------|------------------------------------------------|----------------------------------------------------------------------------------|---------------------------------------|-------------------------|--------------------|-----------|-------------------|----------------------------|----------------------|
| | | | | | | Alarm reset | CPU reset | Cycling the power | | |
| Alarm | 72 | Load-side encoder normal communication error 2 | 72.1 | Load-side encoder data error 1 | EDB | / | / | ○ | Each axis | Each axis |
| | | | 72.2 | Load-side encoder data update error | EDB | / | / | ○ | Each axis | Each axis |
| | | | 72.3 | Load-side encoder data waveform error | EDB | / | / | ○ | Each axis | Each axis |
| | | | 72.4 | Load-side encoder non-signal error | EDB | / | / | ○ | Each axis | Each axis |
| | | | 72.5 | Load-side encoder hardware error 1 | EDB | / | / | ○ | Each axis | Each axis |
| | | | 72.6 | Load-side encoder hardware error 2 | EDB | / | / | ○ | Each axis | Each axis |
| | | | 72.9 | Load-side encoder data error 2 | EDB | / | / | ○ | Each axis | Each axis |
| | 74 | Option card error 1 | 74.1 | Option card error 1 | DB | / | / | ○ | / | / |
| 74.2 | | | Option card error 2 | DB | / | / | ○ | / | / | |
| 74.3 | | | Option card error 3 | DB | / | / | ○ | / | / | |
| 74.4 | | | Option card error 4 | DB | / | / | ○ | / | / | |
| 74.5 | | | Option card error 5 | DB | / | / | ○ | / | / | |
| 75 | Option card error 2 | 75.3 | Option card connection error | EDB | / | / | ○ | / | / | |
| | | 75.4 | Option card disconnected | DB | / | / | ○ | / | / | |
| 79 | Functional safety unit diagnosis error | 79.1 | Functional safety unit power voltage error | DB | ○ (Note 7) | / | ○ | / | / | |
| | | 79.2 | Functional safety unit internal error | DB | / | / | ○ | / | / | |
| | | 79.3 | Abnormal temperature of functional safety unit | SD | ○ (Note 7) | / | ○ | / | / | |
| | | 79.4 | Servo amplifier error | SD | / | / | ○ | / | / | |
| | | 79.5 | Input device error | SD | / | / | ○ | / | / | |
| | | 79.6 | Output device error | SD | / | / | ○ | / | / | |
| | | 79.7 | Mismatched input signal error | SD | / | / | ○ | / | / | |
| | | 79.8 | Position feedback fixing error | DB | / | / | ○ | / | / | |
| 7A | Parameter setting error (safety observation function) | 7A.1 | Parameter verification error (safety observation function) | DB | / | / | ○ | / | / | |
| | | 7A.2 | Parameter setting range error (safety observation function) | DB | / | / | ○ | / | / | |
| | | 7A.3 | Parameter combination error (safety observation function) | DB | / | / | ○ | / | / | |
| | | 7A.4 | Functional safety unit combination error (safety observation function) | DB | / | / | ○ | / | / | |
| 7B | Encoder diagnosis error (safety observation function) | 7B.1 | Encoder diagnosis error 1 (safety observation function) | DB | / | / | ○ | / | / | |
| | | 7B.2 | Encoder diagnosis error 2 (safety observation function) | DB | / | / | ○ | / | / | |
| | | 7B.3 | Encoder diagnosis error 3 (safety observation function) | DB | / | / | ○ | / | / | |
| | | 7B.4 | Encoder diagnosis error 4 (safety observation function) | DB | / | / | ○ | / | / | |
| 7C | Functional safety unit communication diagnosis error (safety observation function) | 7C.1 | Functional safety unit communication setting error (safety observation function) | SD | ○ (Note 7) | ○ | ○ | / | / | |
| | | 7C.2 | Functional safety unit communication data error (safety observation function) | SD | ○ (Note 7) | ○ | ○ | / | / | |
| 7D | Safety observation error | 7D.1 | Stop observation error | DB | ○ (Note 3) | / | ○ | / | / | |
| | | 7D.2 | Speed observation error | DB | ○ (Note 7) | / | ○ | / | / | |
| 82 | Master-slave operation error 1 | 82.1 | Master-slave operation error 1 | EDB | ○ | ○ | ○ | / | / | |

8. TROUBLESHOOTING

| | No. | Name | Detail No. | Detail name | Stop method (Note 2, 3) | Alarm deactivation | | | Processing system (Note 8) | Stop system (Note 8) |
|-------|----------|--------------------------------------------------------------------------------------------------------------|----------------------------------------------------------------------------|------------------------------------------------------------------------|-------------------------|--------------------|-----------|-------------------|----------------------------|----------------------|
| | | | | | | Alarm reset | CPU reset | Cycling the power | | |
| Alarm | 84 | Network module initialization error | 84.1 | Network module undetected error | DB | / | / | ○ | / | / |
| | | | 84.2 | Network module initialization error 1 | DB | / | / | ○ | / | / |
| | | | 84.3 | Network module initialization error 2 | DB | / | / | ○ | / | / |
| | 85 | Network module error | 85.1 | Network module error 1 | SD | / | / | ○ | / | / |
| | | | 85.2 | Network module error 2 | SD | / | / | ○ | / | / |
| | | | 85.3 | Network module error 3 | SD | / | / | ○ | / | / |
| | 86 | Network communication error | 86.1 | Network communication error 1 | SD | ○ | / | ○ | / | / |
| | | | 86.2 | Network communication error 2 | SD | ○ | / | ○ | / | / |
| | | | 86.3 | Network communication error 3 | SD | ○ | / | ○ | / | / |
| | 8A | USB communication time-out error/serial communication time-out error/Modbus RTU communication time-out error | 8A.1 | USB communication time-out error/serial communication time-out error | SD | ○ | ○ | ○ | Common | All axes |
| | | | 8A.2 | Modbus RTU communication time-out error | SD | ○ | ○ | ○ | / | / |
| | 8D | CC-Link IE communication error | 8D.1 | CC-Link IE communication error 1 | SD | ○ | / | ○ | / | / |
| | | | 8D.2 | CC-Link IE communication error 2 | SD | ○ | / | ○ | / | / |
| | | | 8D.3 | Master station setting error 1 | DB | ○ | / | ○ | / | / |
| | | | 8D.5 | Master station setting error 2 | DB | / | / | ○ | / | / |
| | | | 8D.6 | CC-Link IE communication error 3 | SD | ○ | / | ○ | / | / |
| | | | 8D.7 | CC-Link IE communication error 4 | SD | ○ | / | ○ | / | / |
| | | | 8D.8 | CC-Link IE communication error 5 | SD | ○ | / | ○ | / | / |
| | | | 8D.9 | Synchronization error 1 | SD | / | / | ○ | / | / |
| | | | 8D.A | Synchronization error 2 | SD | / | / | ○ | / | / |
| | 8E | USB communication error/serial communication error/Modbus RTU communication error | 8E.1 | USB communication receive error/serial communication receive error | SD | ○ | ○ | ○ | Common | All axes |
| | | | 8E.2 | USB communication checksum error/serial communication checksum error | SD | ○ | ○ | ○ | Common | All axes |
| | | | 8E.3 | USB communication character error/serial communication character error | SD | ○ | ○ | ○ | Common | All axes |
| 8E.4 | | | USB communication command error/serial communication command error | SD | ○ | ○ | ○ | Common | All axes | |
| 8E.5 | | | USB communication data number error/serial communication data number error | SD | ○ | ○ | ○ | Common | All axes | |
| 8E.6 | | | Modbus RTU communication receive error | SD | ○ | ○ | ○ | / | / | |
| 8E.7 | | | Modbus RTU communication message frame error | SD | ○ | ○ | ○ | / | / | |
| 8E.8 | | | Modbus RTU communication CRC error | SD | ○ | ○ | ○ | / | / | |
| 88888 | Watchdog | 8888 | Watchdog | DB | / | / | ○ | Common | All axes | |

8. TROUBLESHOOTING

- Note
1. After resolving the source of trouble, cool the equipment for approximately 30 minutes.
 2. The following shows three stop methods of DB, EDB, and SD.

DB: Stops with dynamic brake. (Coasts for the servo amplifier without dynamic brake.)

Coasts for MR-J4-03A6(-RJ) and MR-J4W2-0303B6. Note that EDB is applied when an alarm below occurs;
[AL. 30.1], [AL. 32.2], [AL. 32.4], [AL. 51.1], [AL. 51.2], [AL. 888]

EDB: Electronic dynamic brake stop (available with specified servo motors)

Refer to the following table for the specified servo motors. The stop method for other than the specified servo motors will be DB.

| Series | Servo motor |
|--------|----------------------------------|
| HG-KR | HG-KR053/HG-KR13/HG-KR23/HG-KR43 |
| HG-MR | HG-MR053/HG-MR13/HG-MR23/HG-MR43 |
| HG-SR | HG-SR51/HG-SR52 |
| HG-AK | HG-AK0136/HG-AK0236/HG-AK0336 |

SD: Forced stop deceleration

3. This is applicable when [Pr. PA04] is set to the initial value. The stop system of SD can be changed to DB using [Pr. PA04].
4. The alarm can be canceled by setting as follows:
For the fully closed loop control: set [Pr. PE03] to "1 _ _ _".
When a linear servo motor or direct drive motor is used: set [Pr. PL04] to "1 _ _ _".
5. In some controller communication status, the alarm factor may not be removed.
6. This alarm will occur only in the J3 compatibility mode.
7. Reset this while all the safety observation functions are stopped.
8. The processing and stop systems are applicable only for the multi-axis servo amplifiers (MR-J4W_-B_). Refer to section 8.1 for details.

8. TROUBLESHOOTING

8.3 Warning list

| | No. | Name | Detail No. | Detail name | Stop method (Note 2, 3) | Processing system (Note 5) | Stop system (Note 5) |
|---------|----------------------|-------------------------------------------|--------------------------------------|----------------------------------------------------------------------|-------------------------|----------------------------|----------------------|
| Warning | 90 | Home position return incomplete warning | 90.1 | Home position return incomplete | | | |
| | | | 90.2 | Home position return abnormal termination | | | |
| | | | 90.5 | Z-phase unpassed | | | |
| | 91 | Servo amplifier overheat warning (Note 1) | 91.1 | Main circuit device overheat warning | | Common | |
| | 92 | Battery cable disconnection warning | 92.1 | Encoder battery cable disconnection warning | | Each axis | |
| | | | 92.3 | Battery degradation | | Each axis | |
| | 93 | ABS data transfer warning | 93.1 | ABS data transfer requirement warning during magnetic pole detection | | | |
| | 95 | STO warning | 95.1 | STO1 off detection | DB | Common | All axes |
| | | | 95.2 | STO2 off detection | DB | Common | All axes |
| | | | 95.3 | STO warning 1 (safety observation function) | DB | | |
| | | | 95.4 | STO warning 2 (safety observation function) | DB | | |
| | | | 95.5 | STO warning 3 (safety observation function) | DB | | |
| | 96 | Home position setting warning | 96.1 | In-position warning at home positioning | | Each axis | |
| | | | 96.2 | Command input warning at home positioning | | Each axis | |
| | | | 96.3 | Servo off warning at home positioning | | | |
| | | | 96.4 | Home positioning warning during magnetic pole detection | | | |
| | 97 | Positioning specification warning | 97.1 | Program operation disabled warning | | | |
| | | | 97.2 | Next station position warning | | | |
| | 98 | Software limit warning | 98.1 | Forward rotation-side software stroke limit reached | | | |
| | | | 98.2 | Reverse rotation-side software stroke limit reached | | | |
| | 99 | Stroke limit warning | 99.1 | Forward rotation stroke end off | (Note 4, 7) | | |
| | | | 99.2 | Reverse rotation stroke end off | (Note 4, 7) | | |
| | | | 99.4 | Upper stroke limit off | (Note 7) | Each axis | |
| | | | 99.5 | Lower stroke limit off | (Note 7) | Each axis | |
| | 9A | Optional unit input data error warning | 9A.1 | Optional unit input data sign error | | | |
| | | | 9A.2 | Optional unit BCD input data error | | | |
| | 9B | Error excessive warning | 9B.1 | Excess droop pulse 1 warning | | Each axis | |
| | | | 9B.3 | Excess droop pulse 2 warning | | Each axis | |
| | | | 9B.4 | Error excessive warning during 0 torque limit | | Each axis | |
| | 9C | Converter error | 9C.1 | Converter unit error | | | |
| 9D | CC-Link IE warning 1 | 9D.1 | Station number switch change warning | | | | |
| | | 9D.2 | Master station setting warning | | | | |
| | | 9D.3 | Overlapping station number warning | | | | |
| | | 9D.4 | Mismatched station number warning | | | | |

8. TROUBLESHOOTING

| | No. | Name | Detail No. | Detail name | Stop method (Note 2, 3) | Processing system (Note 5) | Stop system (Note 5) |
|---------|------------------------------|-------------------------------------|---------------------------------------------|---------------------------------------------------------------|-------------------------|----------------------------|----------------------|
| Warning | 9E | CC-Link IE warning 2 | 9E.1 | CC-Link IE communication warning | | | |
| | 9F | Battery warning | 9F.1 | Low battery | | Each axis | |
| | | | 9F.2 | Battery degradation warning | | Each axis | |
| | E0 | Excessive regeneration warning | E0.1 | Excessive regeneration warning | | Common | |
| | E1 | Overload warning 1 | E1.1 | Thermal overload warning 1 during operation | | Each axis | |
| | | | E1.2 | Thermal overload warning 2 during operation | | Each axis | |
| | | | E1.3 | Thermal overload warning 3 during operation | | Each axis | |
| | | | E1.4 | Thermal overload warning 4 during operation | | Each axis | |
| | | | E1.5 | Thermal overload error 1 during a stop | | Each axis | |
| | | | E1.6 | Thermal overload error 2 during a stop | | Each axis | |
| | | | E1.7 | Thermal overload error 3 during a stop | | Each axis | |
| | | | E1.8 | Thermal overload error 4 during a stop | | Each axis | |
| | E2 | Servo motor overheat warning | E2.1 | Servo motor temperature warning | | Each axis | |
| | E3 | Absolute position counter warning | E3.1 | Multi-revolution counter travel distance excess warning | | | |
| | | | E3.2 | Absolute position counter warning | | Each axis | |
| | | | E3.4 | Absolute positioning counter EEPROM writing frequency warning | | | |
| | | | E3.5 | Encoder absolute positioning counter warning | | Each axis | |
| | E4 | Parameter warning | E4.1 | Parameter setting range error warning | | Each axis | |
| | E5 | ABS time-out warning | E5.1 | Time-out during ABS data transfer | | | |
| | | | E5.2 | ABSM off during ABS data transfer | | | |
| | | | E5.3 | SON off during ABS data transfer | | | |
| | E6 | Servo forced stop warning | E6.1 | Forced stop warning | SD | Common | All axes |
| | | | E6.2 | SS1 forced stop warning 1 (safety observation function) | SD | | |
| | | | E6.3 | SS1 forced stop warning 2 (safety observation function) | SD | | |
| | E7 | Controller forced stop warning | E7.1 | Controller forced stop warning | SD | Common | All axes |
| | E8 | Cooling fan speed reduction warning | E8.1 | Decreased cooling fan speed warning | | Common | |
| | | | E8.2 | Cooling fan stop | | Common | |
| E9 | Main circuit off warning | E9.1 | Servo-on signal on during main circuit off | DB | Common | All axes | |
| | | E9.2 | Bus voltage drop during low speed operation | DB | Common | All axes | |
| | | E9.3 | Ready-on signal on during main circuit off | DB | Common | All axes | |
| | | E9.4 | Converter unit forced stop | DB | | | |
| EA | ABS servo-on warning | EA.1 | ABS servo-on warning | | | | |
| EB | The other axis error warning | EB.1 | The other axis error warning | DB | Each axis | (Note 6) | |
| EC | Overload warning 2 | EC.1 | Overload warning 2 | | Each axis | | |

8. TROUBLESHOOTING

| | No. | Name | Detail No. | Detail name | Stop method (Note 2, 3) | Processing system (Note 5) | Stop system (Note 5) |
|---------|-----|---------------------------------------------------|--------------------------------------------------|--------------------------------------------------------|-------------------------|----------------------------|----------------------|
| Warning | ED | Output watt excess warning | ED.1 | Output watt excess warning | / | Each axis | / |
| | F0 | Tough drive warning | F0.1 | Instantaneous power failure tough drive warning | / | Each axis | / |
| | | | F0.3 | Vibration tough drive warning | / | Each axis | / |
| | F2 | Drive recorder - Miswriting warning | F2.1 | Drive recorder - Area writing time-out warning | / | Common | / |
| | | | F2.2 | Drive recorder - Data miswriting warning | / | Common | / |
| | F3 | Oscillation detection warning | F3.1 | Oscillation detection warning | / | Each axis | / |
| | F4 | Positioning warning | F4.4 | Target position setting range error warning | / | / | / |
| | | | F4.6 | Acceleration time constant setting range error warning | / | / | / |
| | | | F4.7 | Deceleration time constant setting range error warning | / | / | / |
| | | | F4.9 | Home position return type error warning | / | / | / |
| | F5 | Simple cam function - Cam data miswriting warning | F5.1 | Cam data - Area writing time-out warning | / | / | / |
| | | | F5.2 | Cam data - Area miswriting warning | / | / | / |
| | | | F5.3 | Cam data checksum error | / | / | / |
| | F6 | Simple cam function - Cam control warning | F6.1 | Cam axis one cycle current value restoration failed | / | / | / |
| | | | F6.2 | Cam axis feed current value restoration failed | / | / | / |
| | | | F6.3 | Cam unregistered error | / | / | / |
| | | | F6.4 | Cam control data setting range error | / | / | / |
| | | | F6.5 | Cam No. external error | / | / | / |
| | | | F6.6 | Cam control inactive | / | / | / |
| | F7 | Machine diagnosis warning | F7.1 | Vibration failure prediction warning | / | Each axis | / |
| | | | F7.2 | Friction failure prediction warning | / | Each axis | / |
| F7.3 | | | Total travel distance failure prediction warning | / | Each axis | / | |

- Note
- After resolving the source of trouble, cool the equipment for approximately 30 minutes.
 - The following shows two stop methods of DB and SD.
DB: Stops with dynamic brake. (Coasts for the servo amplifier without dynamic brake.)
Coasts for MR-J4-03A6(-RJ) and MR-J4W2-0303B6.
SD: Forced stop deceleration
 - This is applicable when [Pr. PA04] is set to the initial value. The stop system of SD can be changed to DB using [Pr. PA04].
 - For MR-J4-_A_ servo amplifier, quick stop or slow stop can be selected using [Pr. PD30].
 - The processing and stop systems are applicable only for the multi-axis servo amplifiers (MR-J4W_-_B_). Refer to section 1.1 for details.
 - As the initial value, it is applicable only for [AL. 24] and [AL. 32]. All-axis stop can be selected using [Pr. PF02].
 - For MR-J4-_GF_ servo amplifier, quick stop or slow stop can be selected using [Pr. PD12]. (I/O mode only)

8. TROUBLESHOOTING

8.4 Troubleshooting at power on

When the servo system does not boot and system error occurs at power on of the servo system controller, improper boot of the servo amplifier might be the cause. Check the display of the servo amplifier, and take actions according to this section.

| Display | Description | Cause | Checkpoint | Action |
|----------------------------------------|----------------------------------------------------------------------------------|------------------------------------------------------------------------------------------------------------|----------------------------------------------------------------------------------------------------------------------------------------------------------------------------------------------------|---------------------------------------------------------------------------------------------------|
| AA | Communication with the servo system controller has disconnected. | The power of the servo system controller was turned off. | Check the power of the servo system controller. | Switch on the power of the servo system controller. |
| | | SSCNET III cable was disconnected. | "AA" is displayed in the corresponding axis and following axes. | Replace the SSCNET III cable of the corresponding axis. |
| | | | Check if the connectors (CNIA, CNIB) are unplugged. | Connect correctly. |
| | | The power of the servo amplifier was turned off. | "AA" is displayed in the corresponding axis and following axes. | Check the power of the servo amplifier. Replace the servo amplifier of the corresponding axis. |
| Ab | Initialization communication with the servo system controller has not completed. | All axes are in a state of disabling control axis. | Check if the disabling control axis switches (SW2-2, 2-3, and 2-4) are on. | Turn off the disabling control axis switches (SW2-2, 2-3, and 2-4). |
| | | Axis No. is set incorrectly. | Check that the other servo amplifier is not assigned to the same axis No. | Set it correctly. |
| | | Axis No. does not match with the axis No. set to the servo system controller. | Check the setting and axis No. of the servo system controller. | Set it correctly. |
| | | Information about the servo series has not set in the simple motion module. | Check the value set in Servo series (Pr. 100) in the simple motion module. | Set it correctly. |
| | | Communication cycle does not match. | Check the communication cycle at the servo system controller side. When using 8 axes or less: 0.222 ms When using 16 axes or less: 0.444 ms When using 32 axes or less: 0.888 ms | Set it correctly. |
| | | Connection to MR-J4W3-B with software version A2 or earlier was attempted in 0.222 ms communication cycle. | Check if the communication cycle on servo system controller side is 0.222 ms. | Use them with 0.444 ms or more communication cycle. |
| | | SSCNET III cable was disconnected. | "Ab" is displayed in the corresponding axis and following axes. | Replace the SSCNET III cable of the corresponding axis. |
| | | | Check if the connectors (CNIA, CNIB) are unplugged. | Connect correctly. |
| | | The power of the servo amplifier was turned off. | "Ab" is displayed in an axis and the following axes. | Check the power of the servo amplifier. |
| The servo amplifier is malfunctioning. | "Ab" is displayed in an axis and the following axes. | Replace the servo amplifier of the corresponding axis. | | |

8. TROUBLESHOOTING

| Display | Description | Cause | Checkpoint | Action |
|-----------------------------------------------------------------|----------------------------------------------------------------------------------------------------------|--------------------------------------------------------------------------------------------------------------------------------------------------|-------------------------------------------------------------------------------------------------------------|--------------------------------------------------------|
| Ab ↑ ↓ AC or Ab ↓ AC ↓ Ad ↓ Ad | Communication between servo system controller and servo amplifier are repeating connection and shut-off. | An MR-J4-_B(4)(-RJ) servo amplifier or MR-J4W-_B servo amplifier which is set to J3 compatibility mode is connected to the SSCNET III/H network. | Check if "J3 compatibility mode" is set using "MR-J4(W)-B mode selection" which came with MR Configurator2. | Select "J4 mode" with "MR-J4(W)-B mode selection". |
| b##. (Note) | The system has been in the test operation mode. | Test operation mode has been active. | Test operation setting switch (SW2-1) is turned on. | Turn off the test operation setting switch (SW2-1). |
| off | Operation mode for manufacturer setting is set. | Operation mode for manufacturer setting is enabled. | Check if all of the control axis setting switches (SW2) are on. | Set the control axis setting switches (SW2) correctly. |

Note. ## indicates axis No.

9. DIMENSIONS

9. DIMENSIONS

9.1 Servo amplifier

(1) MR-J4W2-22B/MR-J4W2-44B

[Unit: mm]

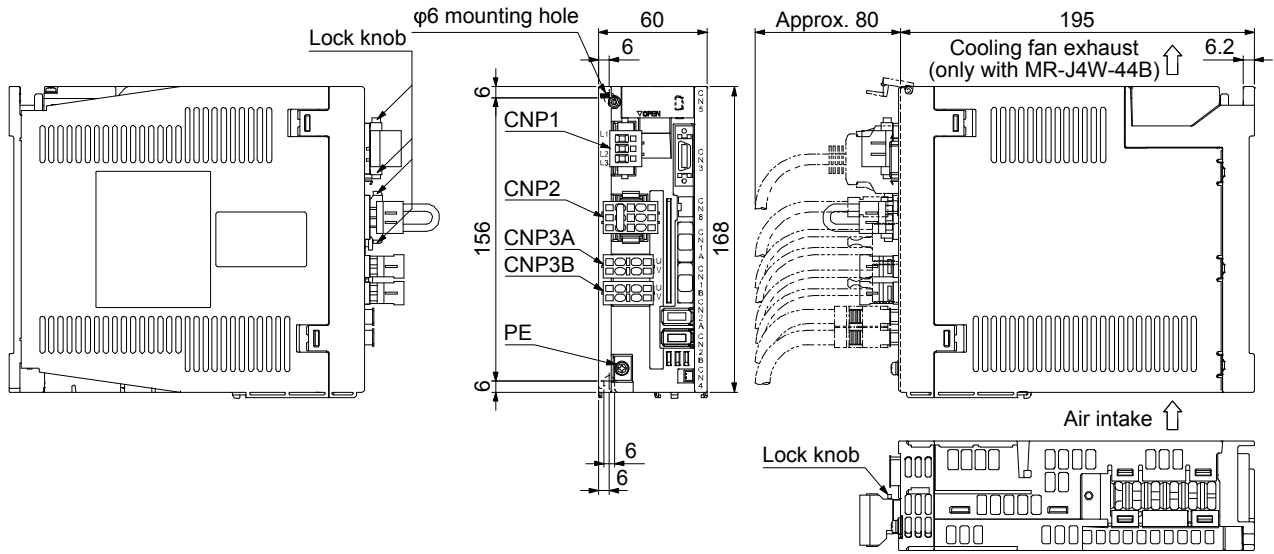

Mass: 1.4 [kg]

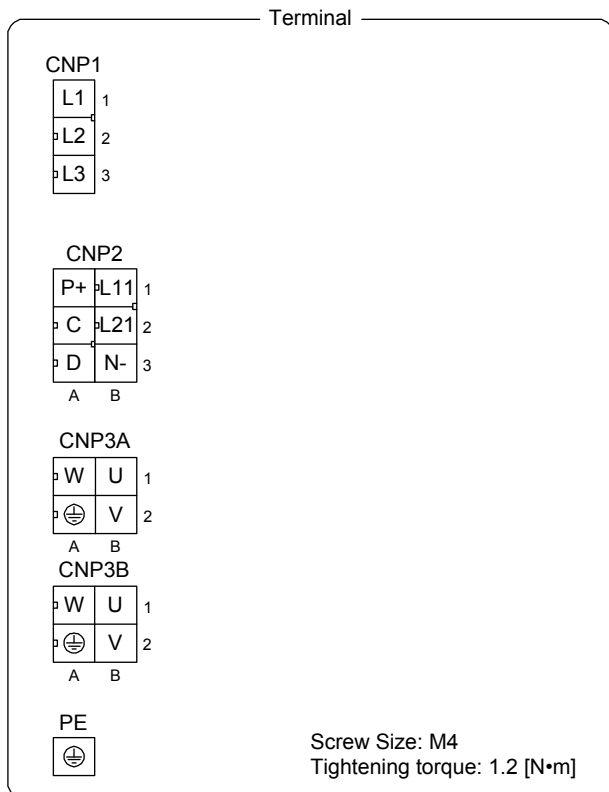

Mounting screw
Screw size: M5
Tightening torque: 3.24 [N•m]

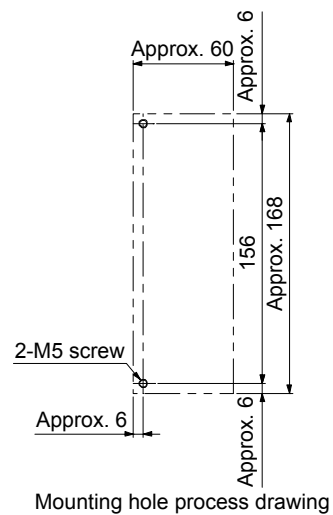

9. DIMENSIONS

(2) MR-J4W2-77B/MR-J4W2-1010B

[Unit: mm]

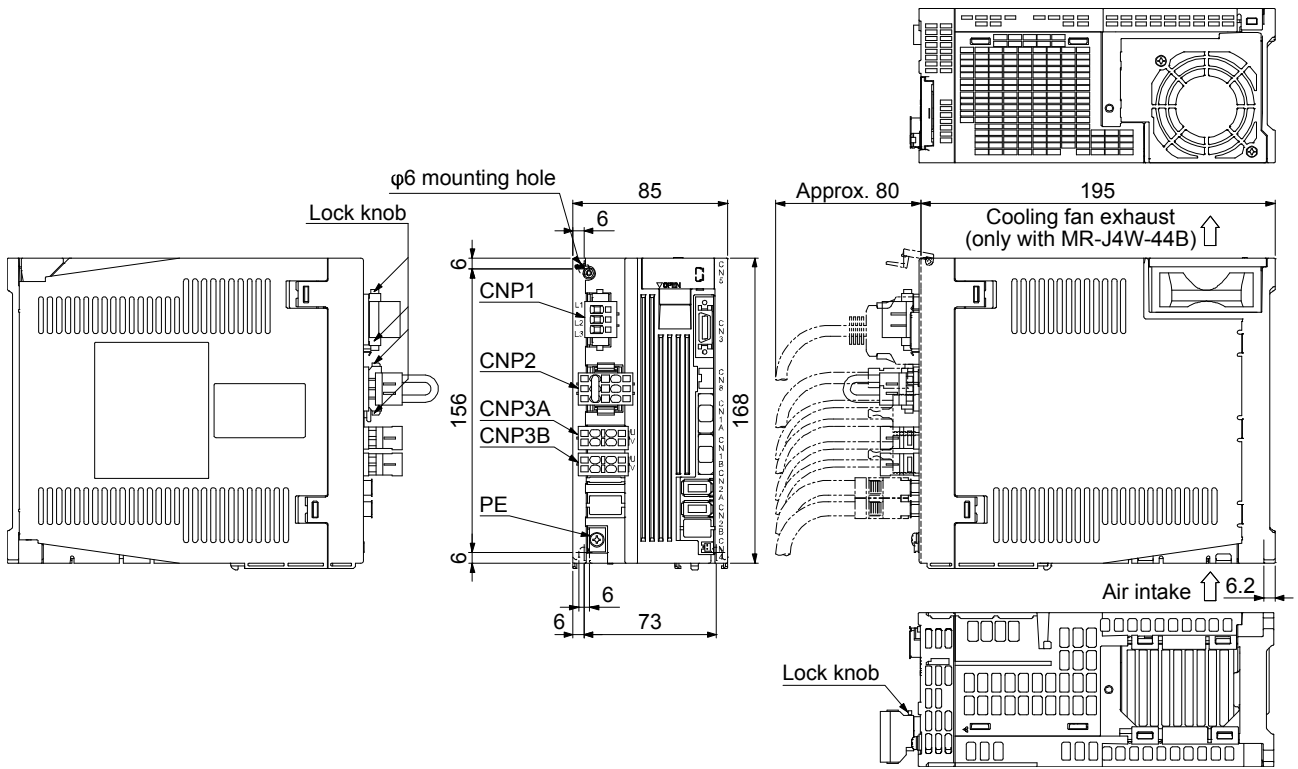

Mass: 2.3 [kg]

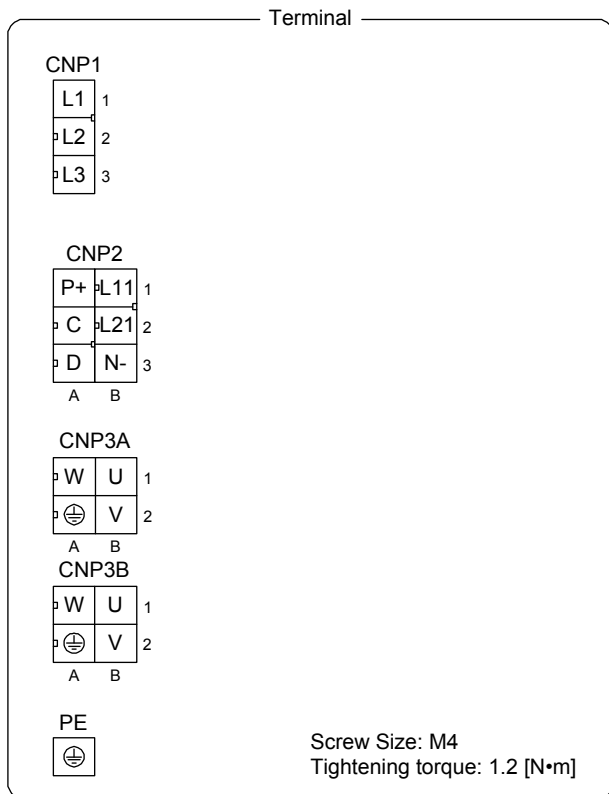

Mounting screw

Screw size: M5

Tightening torque: 3.24 [N•m]

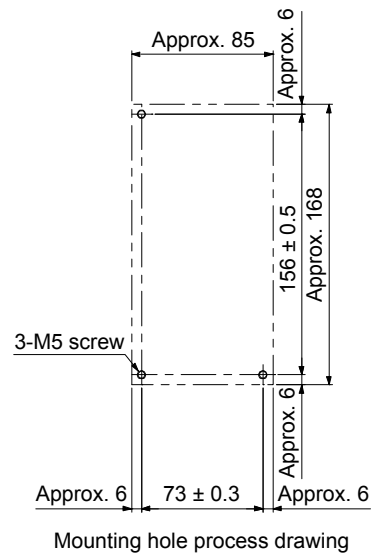

9. DIMENSIONS

(3) MR-J4W3-222B/MR-J4W3-444B

[Unit: mm]

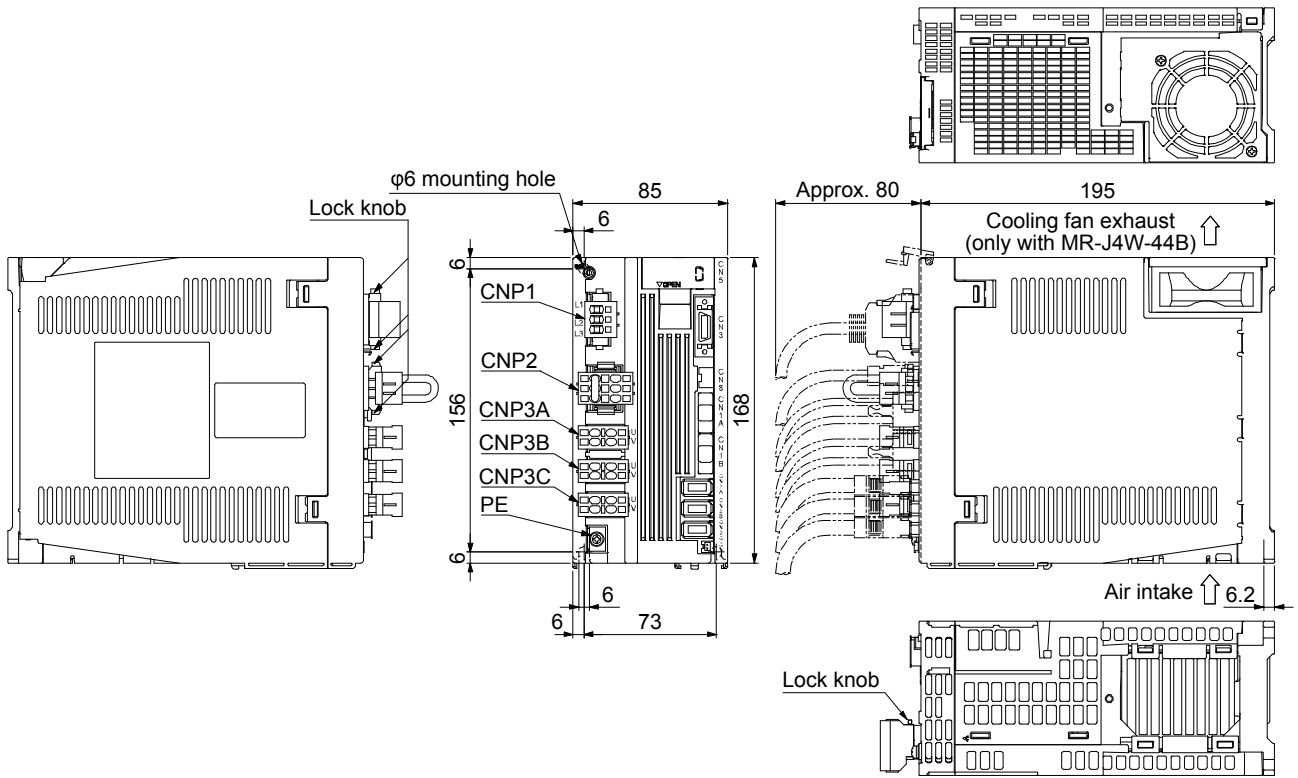

Mass: 2.3 [kg]

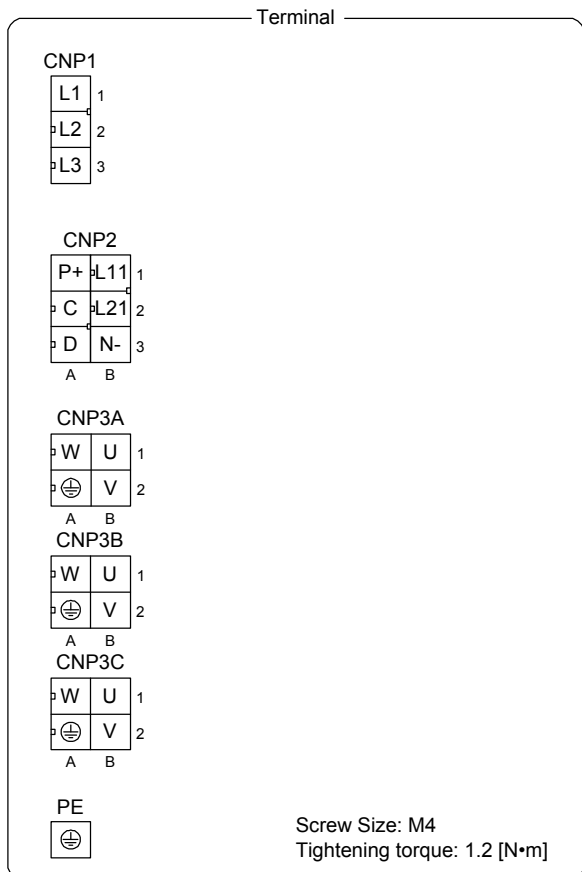

Mounting screw
Screw size: M5
Tightening torque: 3.24 [N·m]

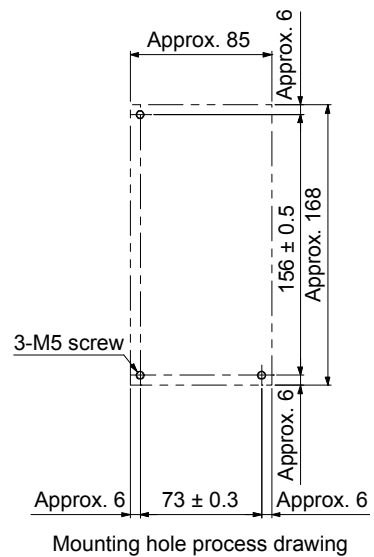

9. DIMENSIONS

9.2 Connector

(1) CN1A/CN1B connector

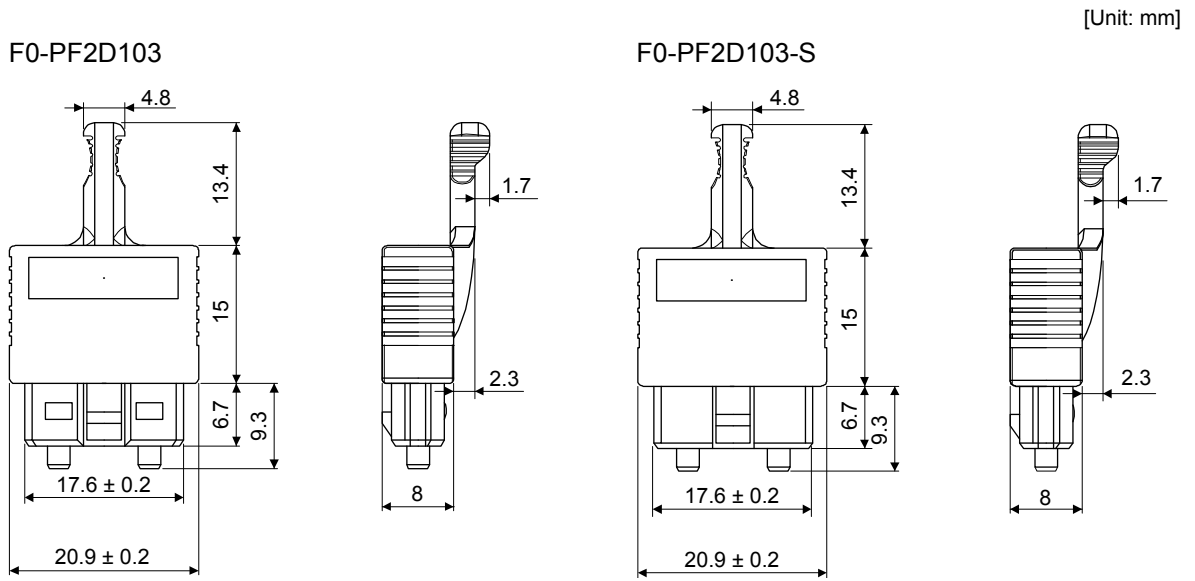

(2) Miniature delta ribbon (MDR) system (3M) (a) One-touch lock type

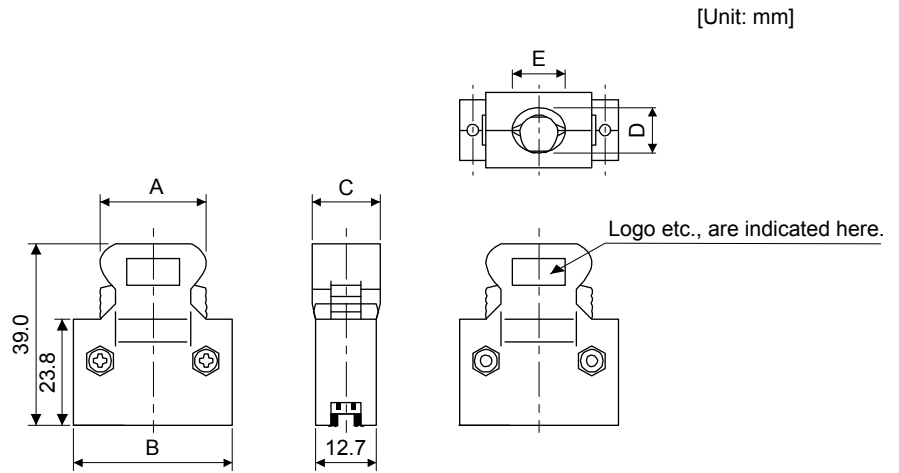

| Connector | Shell kit | Each type of dimension | | | | |
|--------------|----------------|------------------------|------|------|------|------|
| | | A | B | C | D | E |
| 10120-3000PE | 10320-52F0-008 | 22.0 | 33.3 | 14.0 | 10.0 | 12.0 |

9. DIMENSIONS

- (b) Jack screw M2.6 type
This is not available as option.

[Unit: mm]

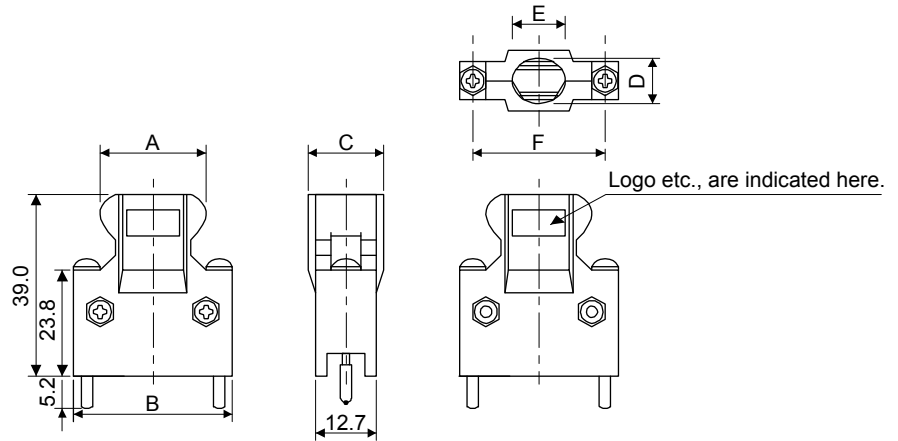

| Connector | Shell kit | Each type of dimension | | | | | |
|--------------|----------------|------------------------|------|------|------|------|------|
| | | A | B | C | D | E | F |
| 10120-3000PE | 10320-52F0-008 | 22.0 | 33.3 | 14.0 | 10.0 | 12.0 | 27.4 |

- (3) SCR connector system (3M)
Receptacle: 36210-0100PL
Shell kit: 36310-3200-008

[Unit: mm]

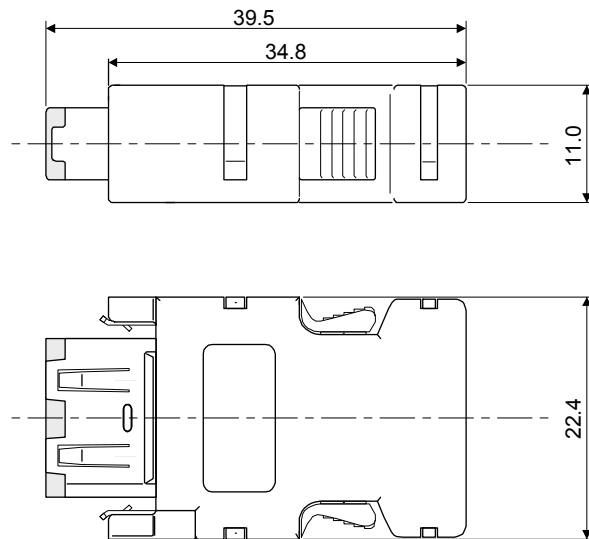

10. CHARACTERISTICS

10. CHARACTERISTICS

| |
|------------------------------------------------------------------------------------------------------------------|
| POINT |
| ● For the characteristics of the linear servo motor and the direct drive motor, refer to sections 14.4 and 15.4. |

10.1 Overload protection characteristics

An electronic thermal is built in the servo amplifier to protect the servo motor, servo amplifier and servo motor power wires from overloads.

[AL. 50 Overload 1] occurs if overload operation performed is above the electronic thermal protection curve shown in fig. 10.1 [AL. 51 Overload 2] occurs if the maximum current is applied continuously for several seconds due to machine collision, etc. Use the equipment on the left-hand side area of the continuous or broken line in the graph.

For the system where the unbalanced torque occurs, such as a vertical axis system, the unbalanced torque of the machine should be kept at 70% or less of the rated torque.

This servo amplifier has solid-state servo motor overload protection for each axis. (The servo motor overload current (full load current) is set on the basis of 120% rated current of the servo amplifier.)

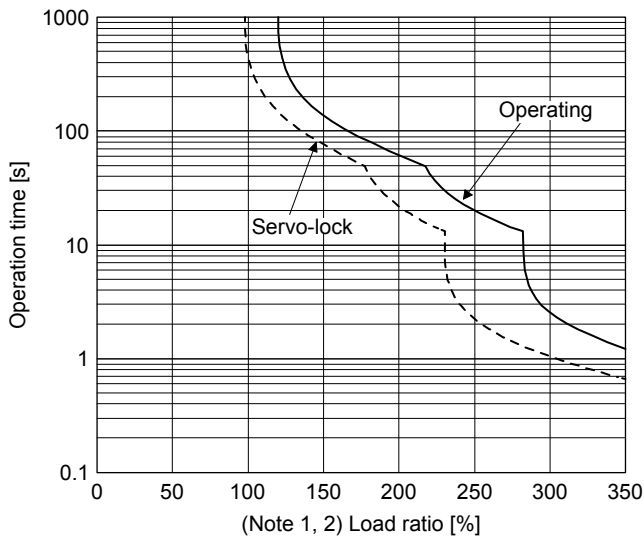

HG-KR053/HG-KR13
HG-MR053/HG-MR13

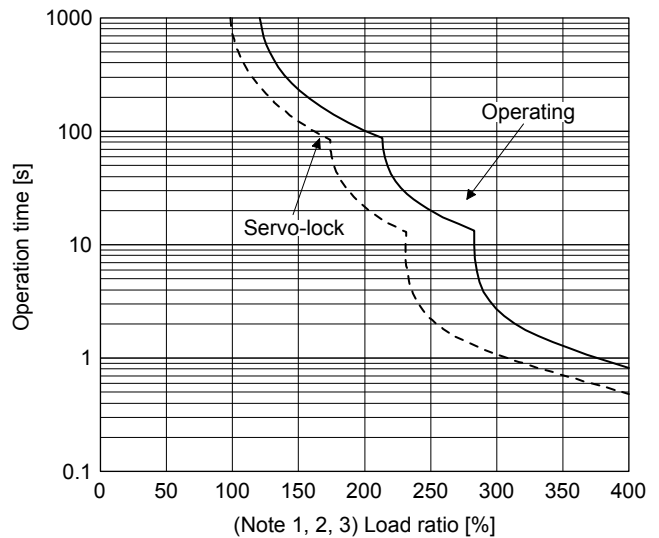

HG-KR23/HG-KR43/HG-KR73
HG-MR23/HG-MR43/HG-MR73
HG-SR51/HG-SR81/HG-SR52/HG-SR102
HG-UR72
HG-JR53/HG-JR73/HG-JR103

- Note 1. If operation that generates torque more than 100% of the rating is performed with an abnormally high frequency in a servo motor stop status (servo-lock status) or in a 50 r/min or less low-speed operation status, the servo amplifier may malfunction regardless of the electronic thermal protection.
- Note 2. The load ratio ranging from 300% to 350% applies to the HG-KR series servo motor.
- Note 3. The load ratio ranging from 350% to 400% applies to the HG-JR53 servo motor.

Fig. 10.1 Electronic thermal protection characteristics

10. CHARACTERISTICS

10.2 Power supply capacity and generated loss

Calculate the generated loss and the power supply capacity of the servo amplifier under rated load from (1) and (2) in this section. The calculated value will vary depending on the number of connected servo motors and the capacities of the servo motors. For thermal design of an enclosed type cabinet, use the values calculated in consideration for the worst operating conditions. The actual amount of generated heat will be intermediate between values at rated torque and servo-off according to the duty used during operation. When the servo motor is run at less than the rated speed, the power supply capacity will be smaller than the calculated value, but the servo amplifier's generated heat will not change.

(1) Calculation method of power supply capacity

Calculate the power supply capacity for one servo amplifier from tables 10.1 and 10.2.

Table 10.1 Power supply capacity for one servo amplifier at rated output

| Servo amplifier | (Note) Power supply capacity [kVA] |
|-----------------|---------------------------------------------------------------------------|
| MR-J4W2-22B | Total power supply capacity of connected servo motors ((A) in table 10.2) |
| MR-J4W2-44B | |
| MR-J4W2-77B | |
| MR-J4W2-1010B | |
| MR-J4W3-222B | |
| MR-J4W3-444B | |

Note. The power supply capacity will vary according to the power supply impedance. This value is applicable when the power factor improving reactor is not used.

Table 10.2 Servo amplifier power supply capacity for one servo motor

| Servo motor | Power supply capacity [kVA] (A) |
|-------------|---------------------------------|
| HG-KR053 | 0.3 |
| HG-KR13 | 0.3 |
| HG-KR23 | 0.5 |
| HG-KR43 | 0.9 |
| HG-KR73 | 1.3 |
| HG-MR053 | 0.3 |
| HG-MR13 | 0.3 |
| HG-MR23 | 0.5 |
| HG-MR43 | 0.9 |
| HG-MR73 | 1.3 |
| HG-SR51 | 1.0 |
| HG-SR81 | 1.5 |
| HG-SR52 | 1.0 |
| HG-SR102 | 1.7 |
| HG-UR72 | 1.3 |
| HG-JR53 | 1.0 |
| HG-JR73 | 1.3 |
| HG-JR103 | 1.7 |

Calculate the power supply capacity with equation 10.1 below.

$$\text{Power supply capacity [kVA]} = \text{Sum of power supply capacity (A) of the connected servo motors} \dots (10.1)$$

For example, when a HG-KR43, HG-KR23, and HG-KR053 are connected to an MR-J4W3-444B servo amplifier, according to table 10.1, the power supply capacity of each servo motor is as follows: HG-KR43 = 0.9 [kVA], HG-KR23 = 0.5 [kVA], HG-KR053 = 0.3 [kVA]. Calculate the values with equation 10.1.

$$\text{Power supply capacity [kVA]} = 0.9 + 0.5 + 0.3 = 1.7$$

Under the above conditions, the power supply capacity of the servo amplifier is 1.7 [kVA].

10. CHARACTERISTICS

(2) Calculation method of the amount of heat generated by the servo amplifier

Calculate the amount of heat generated by one servo amplifier from tables 10.3 and 10.4.

Table 10.3 Amount of heat generated by one servo amplifier at rated output

| Servo amplifier | (Note) Servo amplifier-generated heat [W] | |
|-----------------|--------------------------------------------------------------------------------------------------------------------------------------------------------------------------------------|--------------------|
| | At rated output | With servo-off (C) |
| MR-J4W2-22B | Sum of the total amount of heat generated by the servo amplifier for each servo motor ((B) in table 10.4) and the amount of heat generated by the servo amplifier with servo-off (C) | 20 |
| MR-J4W2-44B | | 20 |
| MR-J4W2-77B | | 20 |
| MR-J4W2-1010B | | 20 |
| MR-J4W3-222B | | 25 |
| MR-J4W3-444B | | 25 |

Note. Heat generated during regeneration is not included in the servo amplifier-generated heat. To calculate heat generated by the regenerative option, refer to section 11.2.

Table 10.4 Amount of heat generated by one servo amplifier for one servo motor

| Servo motor | Servo amplifier-generated heat [W] (B) |
|-------------|----------------------------------------|
| HG-KR053 | 10 |
| HG-KR13 | 10 |
| HG-KR23 | 10 |
| HG-KR43 | 20 |
| HG-KR73 | 35 |
| HG-MR053 | 10 |
| HG-MR13 | 10 |
| HG-MR23 | 10 |
| HG-MR43 | 20 |
| HG-MR73 | 35 |
| HG-SR51 | 25 |
| HG-SR81 | 35 |
| HG-SR52 | 25 |
| HG-SR102 | 35 |
| HG-UR72 | 35 |
| HG-JR53 | 25 |
| HG-JR73 | 35 |
| HG-JR103 | 35 |

Calculate the amount of heat generated by the servo amplifier with equation 10.2 below.

Servo amplifier-generated heat at rated output [W]

= Sum of servo amplifier-generated heat (B) + Servo amplifier-generated heat with servo-off (C) ··· (10.2)

Under the conditions in (1) in this section, according to table 10.3, the amount of heat generated by the servo amplifier for each servo motor is as follows: HG-KR43 = 20 [W], HG-KR23 = 10 [W], HG-KR053 = 10 [W]. According to table 10.4, the amount of heat generated by the servo amplifier with servo-off is 25 [W]. Calculate the values with equation 10.2.

Servo amplifier-generated heat at rated output [W] = (20 + 10 + 10) + 25 = 65

Under the above conditions, the amount of heat generated by the servo amplifier is 65 [W].

10. CHARACTERISTICS

(3) Heat dissipation area for an enclosed type cabinet

The enclosed type cabinet (hereafter called the cabinet) which will contain the servo amplifier should be designed to ensure that its temperature rise is within +10 °C at the ambient temperature of 40 °C. (With an approximately 5 °C safety margin, the system should operate within a maximum 55 °C limit.) The necessary cabinet heat dissipation area can be calculated by equation 10.3.

$$A = \frac{P}{K \cdot \Delta T} \dots\dots\dots (10.3)$$

A: Heat dissipation area [m²]

P: Loss generated in the cabinet [W]

ΔT: Difference between internal and ambient temperatures [°C]

K: Heat dissipation coefficient [5 to 6]

When calculating the heat dissipation area with equation 10.3, assume that P is the sum of all losses generated in the cabinet. Refer to table 10.3 for heat generated by the servo amplifier. "A" indicates the effective area for heat dissipation, but if the cabinet is directly installed on an insulated wall, that extra amount must be added to the cabinet's surface area. The required heat dissipation area will vary with the conditions in the cabinet. If convection in the cabinet is poor and heat builds up, effective heat dissipation will not be possible. Therefore, arrangement of the equipment in the cabinet and the use of a cooling fan should be considered. Table 10.3 lists the cabinet dissipation area for each servo amplifier (guideline) when the servo amplifier is operated at the ambient temperature of 40 °C under rated load.

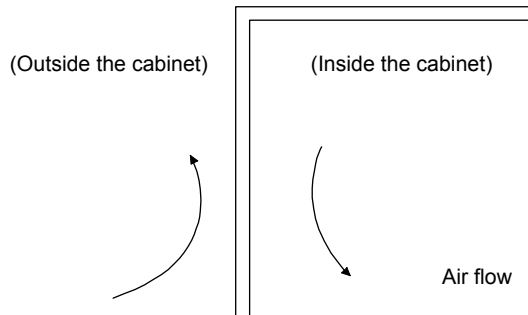

Fig. 10.2 Temperature distribution in an enclosed type cabinet

When air flows along the outer wall of the cabinet, effective heat exchange will be possible, because the temperature slope inside and outside the cabinet will be steeper.

10. CHARACTERISTICS

10.3 Dynamic brake characteristics

CAUTION

- The coasting distance is a theoretically calculated value which ignores the running load such as friction. The calculated value will be longer than the actual distance. If an enough braking distance is not provided, a moving part may crash into the stroke end, which is very dangerous. Install the anti-crash mechanism such as an air brake or an electric/mechanical stopper such as a shock absorber to reduce the shock of moving parts.

POINT

- Do not use dynamic brake to stop in a normal operation as it is the function to stop in emergency.
- For a machine operating at the recommended load to motor inertia ratio or less, the estimated number of usage times of the dynamic brake is 1000 times while the machine decelerates from the rated speed to a stop once in 10 minutes.
- Be sure to enable EM1 (Forced stop 1) after servo motor stops when using EM1 (Forced stop 1) frequently in other than emergency.
- Servo motors for MR-J4 may have the different coasting distance from that of the previous model.
- The electronic dynamic brake operates in the initial state for the HG series servo motors of 600 [W] or smaller capacity. The time constant " τ " for the electronic dynamic brake will be shorter than that of normal dynamic brake. Therefore, coasting distance will be longer than that of normal dynamic brake. For how to set the electronic dynamic brake, refer to [Pr. PF06] and [Pr. PF12].

10. CHARACTERISTICS

10.3.1 Dynamic brake operation

(1) Calculation of coasting distance

Fig. 10.3 shows the pattern in which the servo motor comes to a stop when the dynamic brake is operated. Use equation 10.4 to calculate an approximate coasting distance to a stop. The dynamic brake time constant τ varies with the servo motor and machine operation speeds. (Refer to (2) in this section.)

A working part generally has a friction force. Therefore, actual coasting distance will be shorter than a maximum coasting distance calculated with the following equation.

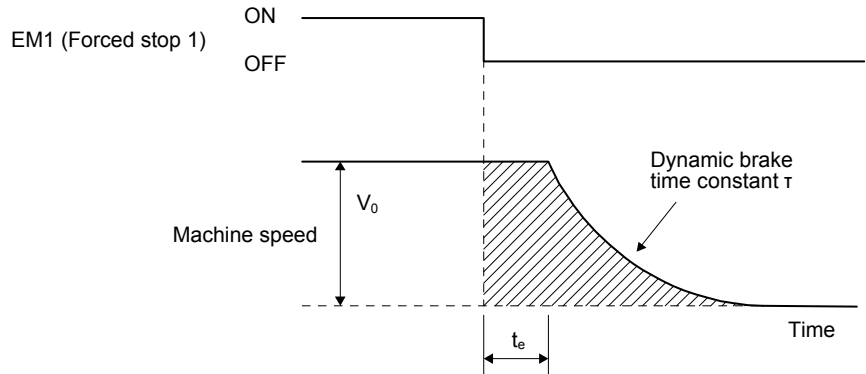

Fig. 10.3 Dynamic brake operation diagram

$$L_{\max} = \frac{V_0}{60} \cdot \left\{ t_e + \tau \left(1 + \frac{J_L}{J_M} \right) \right\} \dots \dots \dots (10.4)$$

- L_{\max} : Maximum coasting distance [mm]
- V_0 : Machine's fast feed speed [mm/min]
- J_M : Moment of inertia of the servo motor [$\times 10^{-4}$ kg·m²]
- J_L : Load moment of inertia converted into equivalent value on servo motor shaft [$\times 10^{-4}$ kg·m²]
- τ : Dynamic brake time constant [s]
- t_e : Delay time of control section [s]

There is internal relay delay time of about 10 ms.

10. CHARACTERISTICS

(2) Dynamic brake time constant

The following shows necessary dynamic brake time constant τ for equation 10.4.

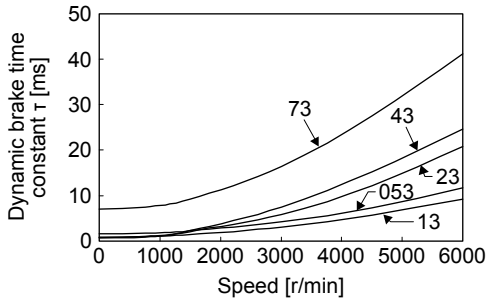

HG-MR series

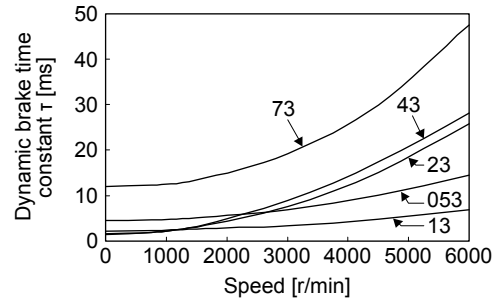

HG-KR series

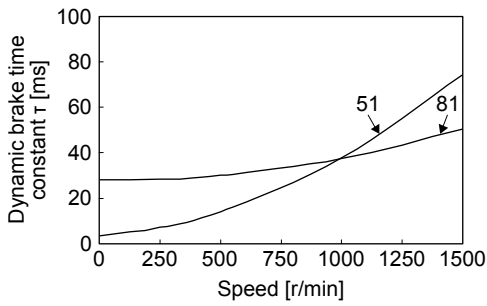

HG-SR 1000 r/min series

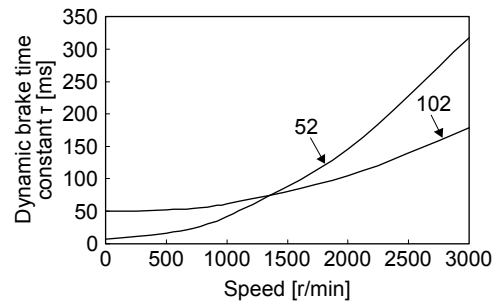

HG-SR 2000 r/min series

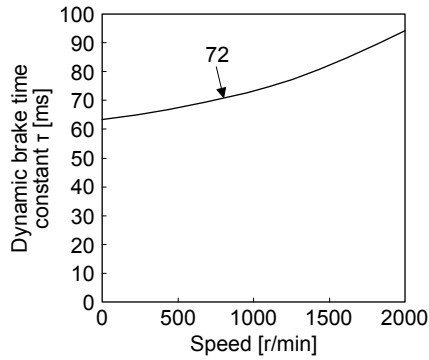

HG-UR series

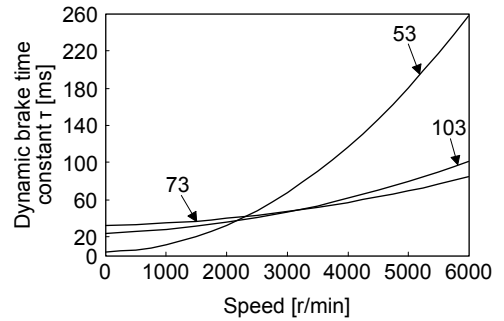

HG-JR3000 r/min series

10. CHARACTERISTICS

10.3.2 Permissible load to motor inertia when the dynamic brake is used

Use the dynamic brake under the load to motor inertia ratio indicated in the following table. If the load inertia moment is higher than this value, the dynamic brake may burn. If there is a possibility that the load inertia moment may exceed the value, contact your local sales office.

The values of the permissible load to motor inertia ratio in the table are the values at the maximum rotation speed of the servo motor.

| Servo motor | Permissible load to motor inertia ratio [multiplier] |
|-------------|------------------------------------------------------|
| HG-KR053 | 30 |
| HG-KR13 | |
| HG-KR23 | |
| HG-KR43 | |
| HG-KR73 | |
| HG-MR053 | 35 |
| HG-MR13 | 32 |
| HG-MR23 | |
| HG-MR43 | |
| HG-MR73 | |

| Servo motor | Permissible load to motor inertia ratio [multiplier] |
|-------------|------------------------------------------------------|
| HG-SR51 | 30 |
| HG-SR81 | |
| HG-SR52 | |
| HG-SR102 | |
| HG-UR72 | |
| HG-JR53 | |
| HG-JR73 | |
| HG-JR103 | |

10. CHARACTERISTICS

10.4 Cable bending life

The bending life of the cables is shown below. This graph calculated values. Since they are not guaranteed values, provide a little allowance for these values.

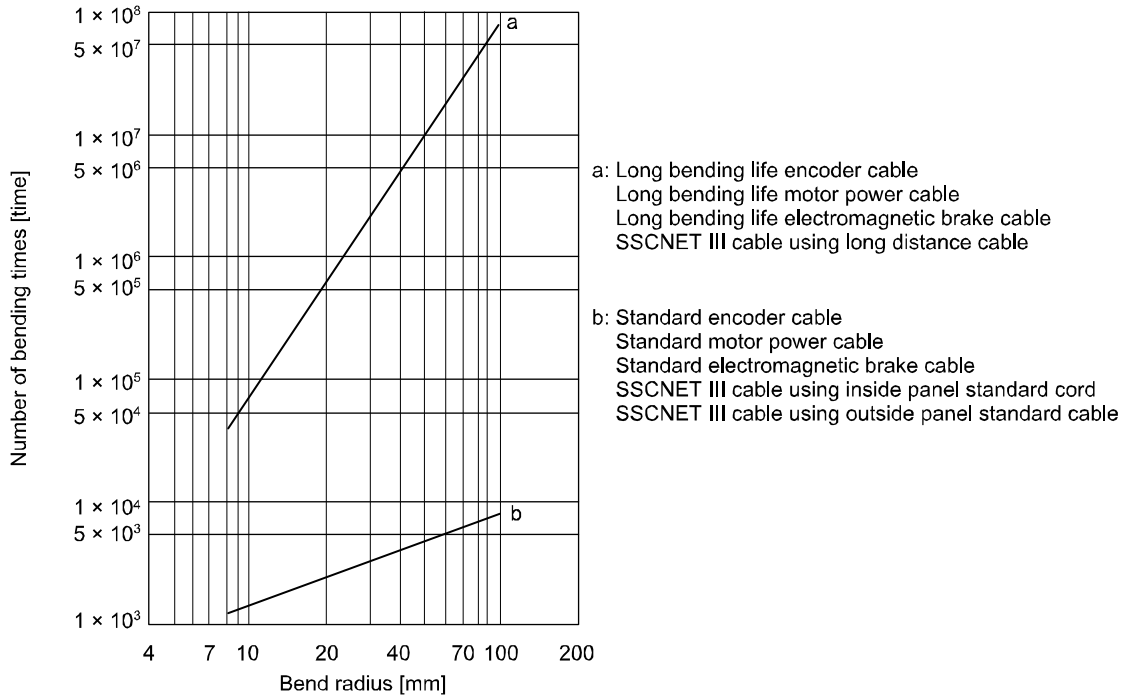

10.5 Inrush currents at power-on of main circuit and control circuit

| |
|-------------------------------------------------------------------------------------------------------------------------------------------------------------------|
| POINT |
| <p>● For a servo amplifier of 600 W or less, the inrush current values can change depending on frequency of turning on/off the power and ambient temperature.</p> |

Since large inrush currents flow in the power supplies, always use molded-case circuit breakers and magnetic contactors. (Refer to section 11.6.)

When circuit protectors are used, it is recommended that the inertia delay type, which is not tripped by an inrush current, be used.

The following table indicates the inrush currents (reference data) that will flow when 240 V AC is applied at the power supply capacity of 2500 kVA and the wiring length of 1 m. Even when you use a 1-phase 200 V AC power supply with MR-J4W2-22B to MR-J4W2-77B, MR-J4W3-222B, and MR-J4W3-444B, the inrush currents of the main circuit power supply is the same.

| MR-J4 2-axis servo amplifier | MR-J4 3-axis servo amplifier | Inrush currents (A _{0-P}) | |
|---------------------------------|---------------------------------|--------------------------------------|----------------------------------------------|
| | | Main circuit power supply (L1/L2/L3) | Control circuit power supply (L11/L21) |
| MR-J4W2-22B | MR-J4W3-222B | 113 A | 24 A (attenuated to approx. 2 A in 20 ms) |
| MR-J4W2-44B | MR-J4W3-444B | (attenuated to approx. 6 A in 20 ms) | |
| MR-J4W2-77B | | 113 A | |
| MR-J4W2-1010B | | (attenuated to approx. 11A in 20 ms) | |

11. OPTIONS AND PERIPHERAL EQUIPMENT

11. OPTIONS AND PERIPHERAL EQUIPMENT

| | |
|--------------------------------------------------------------------------------------------------|-------------------------------------------------------------------------------------------------------------------------------------------------------------------------------------------------------------------------------------------------------------------------------------------------------------------------------------------------------------------------------------------------------------------------------------------------------------|
|  WARNING | <ul style="list-style-type: none">● Before connecting any option or peripheral equipment, turn off the power and wait for 15 minutes or more until the charge lamp turns off. Then, confirm that the voltage between P+ and N- is safe with a voltage tester and others. Otherwise, an electric shock may occur. In addition, when confirming whether the charge lamp is off or not, always confirm it from the front of the servo amplifier. |
|--------------------------------------------------------------------------------------------------|-------------------------------------------------------------------------------------------------------------------------------------------------------------------------------------------------------------------------------------------------------------------------------------------------------------------------------------------------------------------------------------------------------------------------------------------------------------|

| | |
|--------------------------------------------------------------------------------------------------|-----------------------------------------------------------------------------------------------------------------------------------------|
|  CAUTION | <ul style="list-style-type: none">● Use the specified auxiliary equipment and options to prevent a malfunction or a fire. |
|--------------------------------------------------------------------------------------------------|-----------------------------------------------------------------------------------------------------------------------------------------|

| |
|-----------------------------------------------------------------------------------------------------------------------------------------------------------------------------------------------------------------------------------------------------|
| POINT |
| <ul style="list-style-type: none">● We recommend using HIV wires to wire the servo amplifiers, options, and peripheral equipment. Therefore, the recommended wire sizes may differ from those used for the previous servo amplifiers. |

11.1 Cable/connector sets

| |
|-------------------------------------------------------------------------------------------------------------------------------------------------------------------------------------------------------------------------------------------------------------------------------------------------------------------------------------------------------------------------------------|
| POINT |
| <ul style="list-style-type: none">● The IP rating indicated for cables and connectors is their protection against ingress of dust and raindrops when they are connected to a servo amplifier or servo motor. If the IP rating of the cable, connector, servo amplifier and servo motor vary, the overall IP rating depends on the lowest IP rating of all components. |

Purchase the cable and connector options indicated in this section.

11. OPTIONS AND PERIPHERAL EQUIPMENT



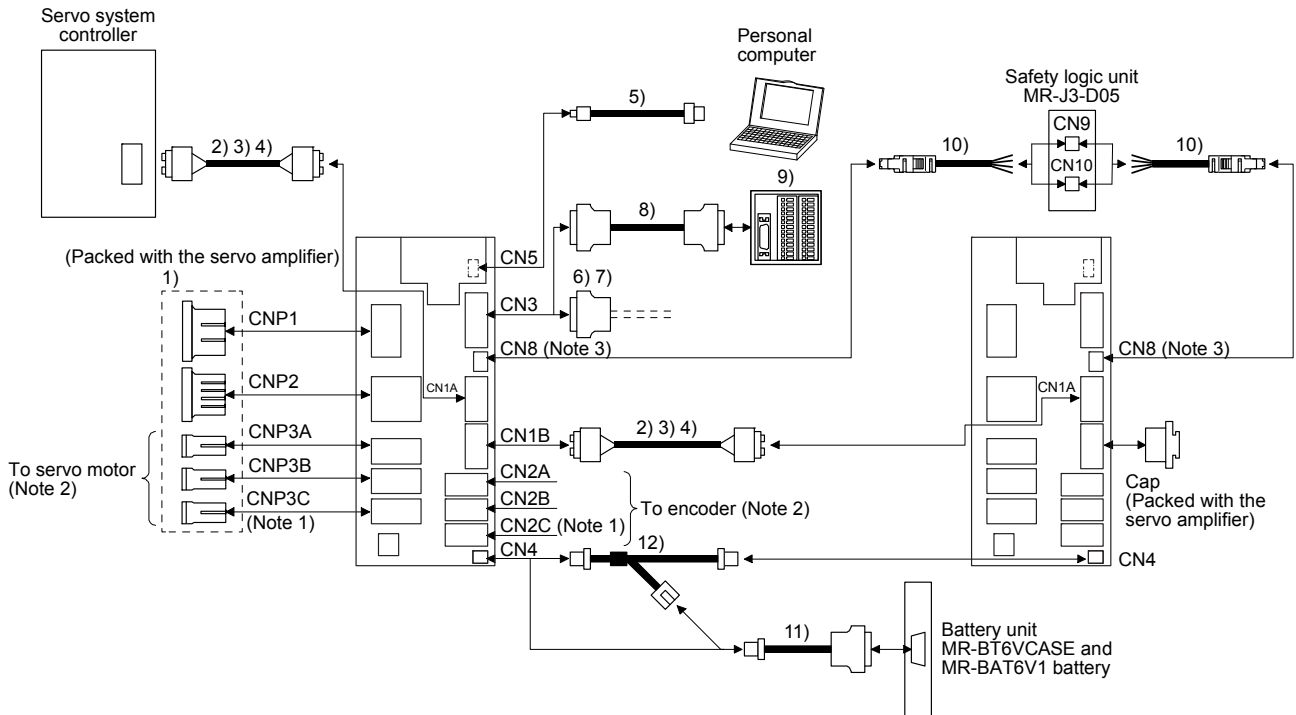

11.1.1 Combinations of cable/connector sets

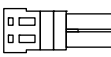
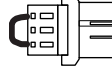
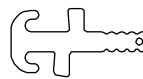

- Note 1. CNP3 and CN2C are available only on MR-J4 3-axis servo amplifier.
 Note 2. Refer to each servo amplifier instruction manual for options for connecting the servo amplifier and the servo motor.
 Note 3. When not using the STO function, attach a short-circuit connector (13) supplied with a servo amplifier.

| No. | Product | Model | Description | Remark | |
|-----|-------------------------------------|-------|--------------------------------------------------------------------------------------------------------------------------------------------------------------------------------------------------------------------------------------------------------------------------------------------------------------------------------------------------------------------------------------------------------------------------------------------------------------------------------------------|----------------------------------------------------------------------------------------------------------------------------------------------------------------------------------------------------------------------------------------------------------------------------------------------------------------------------------------------------------------------------------|-------------------------------|
| 1) | Servo amplifier power connector set | |  CNP1 connector Quantity: 1 Model: 03JFAT-SAXGFK-43 (JST) Applicable wire size: AWG 16 to 14 Insulator OD: to 4.2 mm  CNP3A/CNP3B/CNP3C connector Quantity: 2 (MR-J4W2) 3 (MR-J4W3) Model: 04JFAT-SAGG-G-KK (JST) Applicable wire size: AWG 18 to 14 Insulator OD: to 3.8 mm |  CNP2 connector Quantity: 1 Model: 06JFAT-SAXYGG-F-KK (JST) Applicable wire size: AWG 16 to 14 Insulator OD: to 3.8 mm  Open tool Quantity: 1 Model: J-FAT-OT-EXL (JST) | Supplied with servo amplifier |

11. OPTIONS AND PERIPHERAL EQUIPMENT

| No. | Product | Model | Description | | Remark |
|-----|-------------------------------|-----------------------------------------------------------------------------|--------------------------------------------------------------------------------------------------------------|-------------------------------------------------------------------------------------------------------------------|-------------------------------------------------------------------------|
| 2) | SSCNET III cable | MR-J3BUS_M Cable length: 0.15 m to 3 m (Refer to section 11.1.2.) | Connector: PF-2D103 (JAE) | Connector: PF-2D103 (JAE) | Standard cord inside panel |
| 3) | SSCNET III cable | MR-J3BUS_M-A Cable length: 5 m to 20 m (Refer to section 11.1.2.) |  | | Standard cable outside panel |
| 4) | SSCNET III cable | MR-J3BUS_M-B Cable length: 30 m to 50 m (Refer to section 11.1.2.) | Connector: CF-2D103-S (JAE) | Connector: CF-2D103-S (JAE) | Long-distance cable |
| 5) | USB cable | MR-J3USBCBL3M Cable length: 3 m | CN5 connector mini-B connector (5 pins) | Personal computer connector A connector | For connection with PC-AT compatible personal computer |
| 6) | Connector set | MR-J2CMP2 |  | | Connector: 10126-3000PE Shell kit: 10326-52F0-008 (3M or equivalent) |
| 7) | Connector set | MR-ECN1 |  | | Connector: 10126-3000PE Shell kit: 10326-52F0-008 (3M or equivalent) |
| 8) | Junction terminal block cable | MR-TBNATBL_M Cable length: 0.5/1 m (Refer to section 11.12.) | Junction terminal block connector Connector: 10126-6000EL Shell kit: 10326-3210-000 (3M or equivalent) | Servo amplifier-side connector Connector: 10126-6000EL Shell kit: 10326-3210-000 (3M or equivalent) | For junction terminal block connection |
| 9) | Junction terminal block | MR-TB26A | Refer to section 11.12. | | |
| 10) | STO cable | MR-D05UDL3M-B |  | | Connector set: 2069250-1 (TE Connectivity) |
| 11) | Battery cable | MR-BT6V1CBL_M Cable length: 0.3/1 m (Refer to section 11.1.3.) | Housing: PAP-02V-O Contact: SPHD-001G-P0.5 (JST) | Connector: 10114-3000PE Shell kit: 10314-52F0-008 (3M or equivalent) | For connection with battery unit |
| 12) | Junction battery cable | MR-BT6V2CBL_M Cable length: 0.3/1 m (Refer to section 11.1.3.) | Housing: PAP-02V-O Contact: SPHD-001G-P0.5 (JST) | Housing: PALR-02VF-O Contact: SPAL-001GU-P0.5 (JST) Housing: PAP-02V-O Contact: SPHD-001G-P0.5 (JST) | For battery junction |
| 13) | Short-circuit connector | |  | | Supplied with servo amplifier |

11. OPTIONS AND PERIPHERAL EQUIPMENT

11.1.2 SSCNET III cable

| POINT |
|-----------------------------------------------------------------------------------------------------------------------------------------------------------------------------------------------------------------------------------------------------------------------------------------------------------------------------------|
| <ul style="list-style-type: none"> ● Do not look directly at the light generated from CN1A/CN1B connector of servo amplifier or the end of SSCNET III cable. The light can be a discomfort when it enters the eye. ● Refer to app. 9 for long distance cable over 50 m and ultra-long bending life cable. |

(1) Model explanations

The numbers in the cable length field of the table indicate the symbol filling the underline "_" in the cable model. The cables of the lengths with the symbols are available.

| Cable model | Cable length | | | | | | | | | | | Bending life | Application/remark | |
|------------------------|--------------|-------|-------|-----|-----|-----|------|------|------|------|------|--------------|--------------------|------------------------------------|
| | 0.15 m | 0.3 m | 0.5 m | 1 m | 3 m | 5 m | 10 m | 20 m | 30 m | 40 m | 50 m | | | |
| MR-J3BUS_M | 015 | 03 | 05 | 1 | 3 | | | | | | | | Standard | Using inside panel standard cord |
| MR-J3BUS_M-A | | | | | | 5 | 10 | 20 | | | | | Standard | Using outside panel standard cable |
| MR-J3BUS_M-B (Note) | | | | | | | | | | 30 | 40 | 50 | Long bending life | Using long distance cable |

Note. For cable of 30 m or less, contact your local sales office.

(2) Specifications

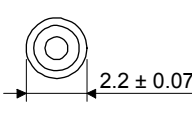
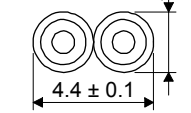
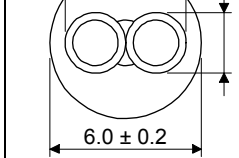
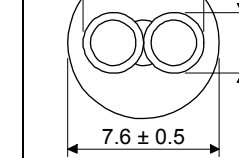
| | | Description | | | |
|--------------------------|-------------------------------------------------------------------------------------|-------------------------------------------------------------------------------------|--------------------------------------------------------------------------------------|---------------------------------------------------------------------------------------|-------------------------------------------------|
| SSCNET III cable model | | MR-J3BUS_M | | MR-J3BUS_M-A | MR-J3BUS_M-B |
| SSCNET III cable length | | 0.15 m | 0.3 m to 3 m | 5 m to 20 m | 30 m to 50 m |
| Optical cable (cord) | Minimum bend radius | 25 mm | | Enforced covering cable 50 mm Cord: 25 mm | Enforced covering cable 50 mm Cord: 30 mm |
| | Tension strength | 70 N | 140 N | 420 N (Enforced covering cable) | 980 N (Enforced covering cable) |
| | Temperature range for use (Note) | -40 °C to 85 °C | | | -20 °C to 70 °C |
| | Ambience | Indoors (no direct sunlight) No solvent or oil | | | |
| External appearance [mm] |  |  |  |  | |

Note. This temperature range for use is the value for optical cable (cord) only. Temperature condition for the connector is the same as that for servo amplifier.

11. OPTIONS AND PERIPHERAL EQUIPMENT

- (3) Dimensions
 - (a) MR-J3BUS015M

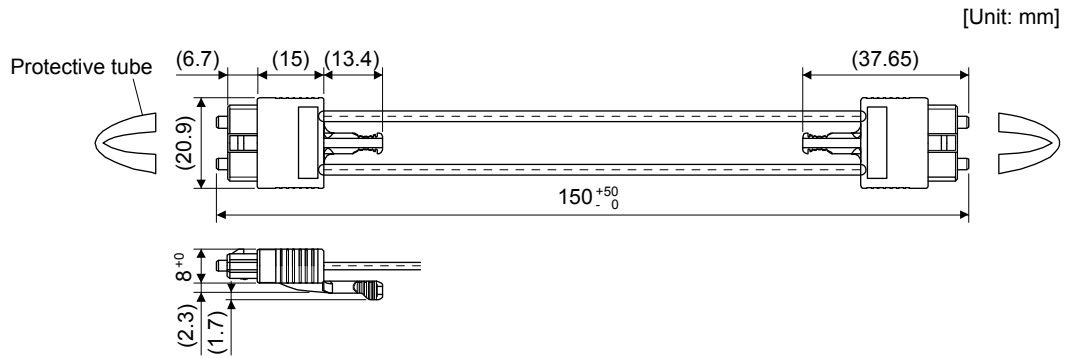

- (b) MR-J3BUS03M to MR-J3BUS3M
 - Refer to the table shown in (1) in this section for cable length (L).

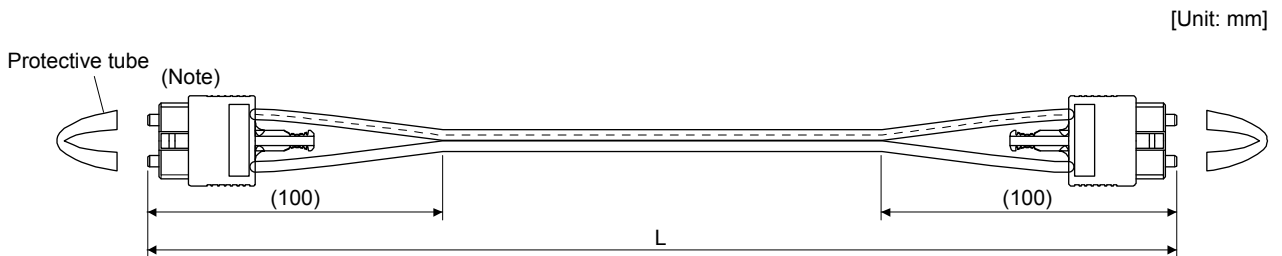

Note. Dimension of connector part is the same as that of MR-J3BUS015M.

- (c) MR-J3BUS5M-A to MR-J3BUS20M-A/MR-J3BUS30M-B to MR-J3BUS50M-B
 - Refer to the table shown in (1) in this section for cable length (L).

| SSCNET III cable | Variable dimensions [mm] | |
|--------------------------------|--------------------------|----|
| | A | B |
| MR-J3BUS5M-A to MR-J3BUS20M-A | 100 | 30 |
| MR-J3BUS30M-B to MR-J3BUS50M-B | 150 | 50 |

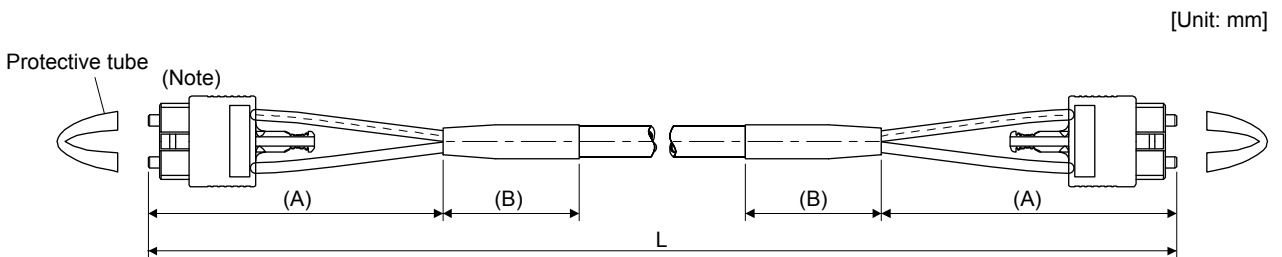

Note. Dimension of connector part is the same as that of MR-J3BUS015M.

11. OPTIONS AND PERIPHERAL EQUIPMENT

11.1.3 Battery cable/junction battery cable

(1) Model explanations

The numbers in the cable length field of the table indicate the symbol filling the underline "_" in the cable model. The cables of the lengths with the symbols are available.

| Cable model | Cable length | | Bending life | Application/remark |
|---------------|--------------|-----|--------------|---------------------------------|
| | 0.3 m | 1 m | | |
| MR-BT6V1CBL_M | 03 | 1 | Standard | For connection with MR-BT6VCASE |
| MR-BT6V2CBL_M | 03 | 1 | Standard | For junction |

(2) MR-BT6V1CBL_M

(a) Appearance

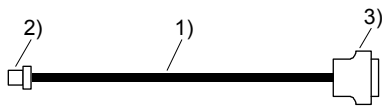

| Components | Description |
|--------------|-------------------------------------------------------------------------|
| 1) Cable | VSVC 7/0.18 × 2C |
| 2) Connector | Housing: PAP-02V-O Contact: SPHD-001G-P0.5 (JST) |
| 3) Connector | Connector: 10114-3000PE Shell kit: 10314-52F0-008 (3M or equivalent) |

(b) Internal wiring diagram

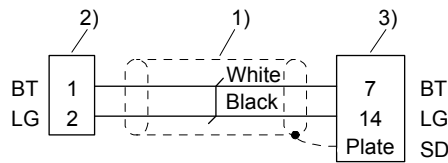

(3) MR-BT6V2CBL_M

(a) Appearance

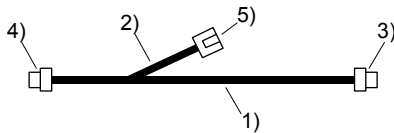

| Components | Description |
|--------------|--------------------------------------------------------|
| 1) Cable | VSVC 7/0.18 × 2C |
| 2) Cable | VSVC 7/0.18 × 2C |
| 3) Connector | Housing: PAP-02V-O |
| 4) Connector | Contact: SPHD-001G-P0.5 (JST) |
| 5) Connector | Housing: PALR-02VF-O Contact: SPAL-001GU-P0.5 (JST) |

(b) Internal wiring diagram

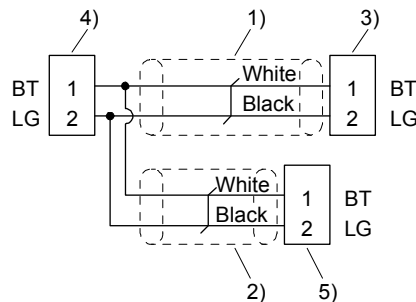

11. OPTIONS AND PERIPHERAL EQUIPMENT

11.1.4 MR-D05UDL3M-B STO cable

This cable is for connecting an external device to the CN8 connector.

| Cable model | Cable length | Application/remark |
|---------------|--------------|----------------------------------------|
| MR-D05UDL3M-B | 3 m | Connection cable for the CN8 connector |

(1) Configuration diagram

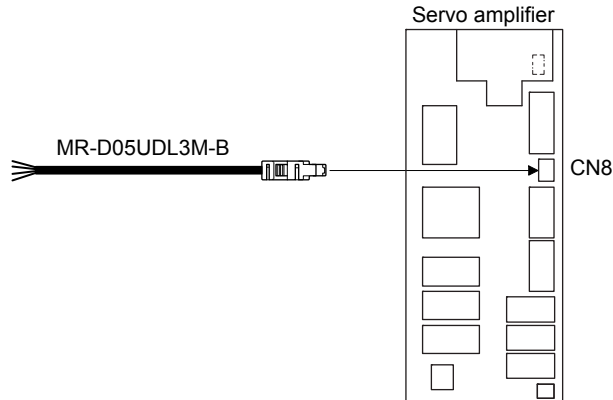

(2) Internal wiring diagram

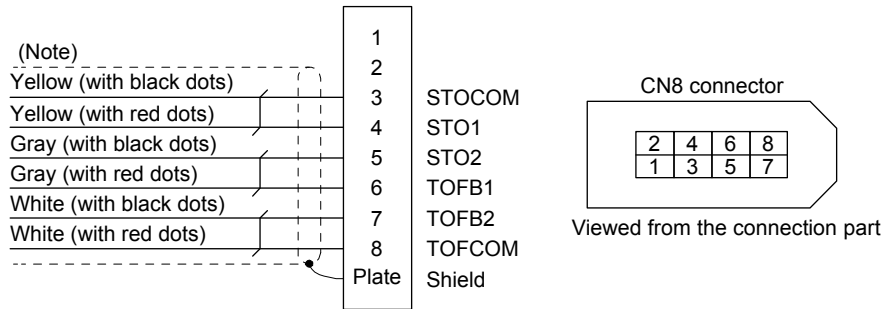

Note. Do not use the two core wires with orange sheath (with red or black dots).

11.2 Regenerative options

CAUTION ● Do not use servo amplifiers with regenerative options other than the combinations specified below. Otherwise, it may cause a fire.

11.2.1 Combination and regenerative power

The power values in the table are resistor-generated powers and not rated powers.

| Servo amplifier | Regenerative power [W] | | | |
|-----------------|--------------------------------|----------------|----------------|----------------|
| | Built-in regenerative resistor | MR-RB14 [26 Ω] | MR-RB34 [26 Ω] | MR-RB3N [26 Ω] |
| MR-J4W2-22B | 20 | 100 | | |
| MR-J4W2-44B | | | | |
| MR-J4W2-77B | 100 | | | 300 |
| MR-J4W2-1010B | | | | |
| MR-J4W3-222B | 30 | 100 | 300 | |
| MR-J4W3-444B | | | | |

11. OPTIONS AND PERIPHERAL EQUIPMENT

11.2.2 Selection of regenerative option

Use the following method when regeneration occurs continuously in vertical motion applications or when it is desired to make an in-depth selection of the regenerative option.

(1) Regenerative energy calculation

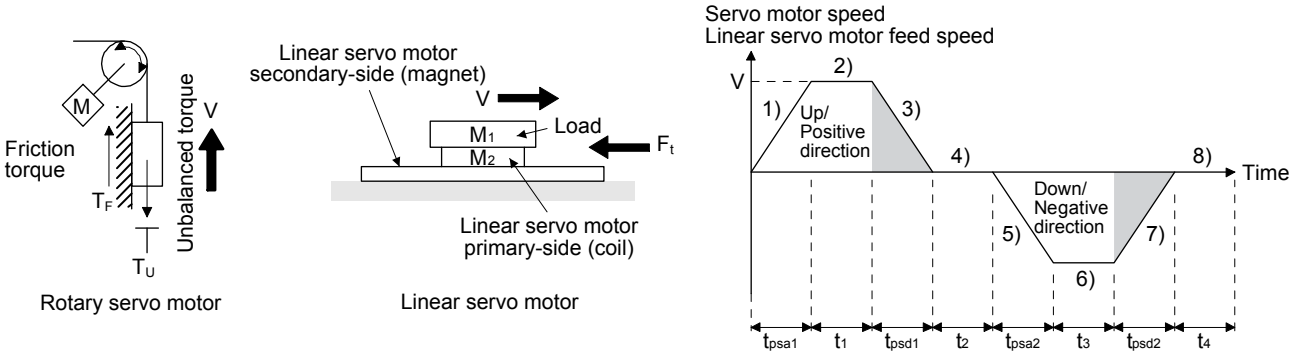

The following shows equations of the rotary servo motor torque and energy at the driving pattern above.

| Section | Torque applied to servo motor [N·m] (Note) | Energy E [J] |
|---------|-------------------------------------------------------------------------------------------------------|-----------------------------------------------------------|
| 1) | $T_1 = \frac{(J_L/\eta + J_M) \cdot V}{9.55 \times 10^4} \cdot \frac{1}{t_{psa1}} + T_U + T_F$ | $E_1 = \frac{0.1047}{2} \cdot V \cdot T_1 \cdot t_{psa1}$ |
| 2) | $T_2 = T_U + T_F$ | $E_2 = 0.1047 \cdot V \cdot T_2 \cdot t_1$ |
| 3) | $T_3 = \frac{-(J_L \cdot \eta + J_M) \cdot V}{9.55 \times 10^4} \cdot \frac{1}{t_{psd1}} + T_U + T_F$ | $E_3 = \frac{0.1047}{2} \cdot V \cdot T_3 \cdot t_{psd1}$ |
| 4), 8) | $T_4, T_8 = T_U$ | $E_4, E_8 \geq 0$ (No regeneration) |
| 5) | $T_5 = \frac{(J_L/\eta + J_M) \cdot V}{9.55 \times 10^4} \cdot \frac{1}{t_{psa2}} - T_U + T_F$ | $E_5 = \frac{0.1047}{2} \cdot V \cdot T_5 \cdot t_{psa2}$ |
| 6) | $T_6 = -T_U + T_F$ | $E_6 = 0.1047 \cdot V \cdot T_6 \cdot t_3$ |
| 7) | $T_7 = \frac{-(J_L \cdot \eta + J_M) \cdot V}{9.55 \times 10^4} \cdot \frac{1}{t_{psd2}} - T_U + T_F$ | $E_7 = \frac{0.1047}{2} \cdot V \cdot T_7 \cdot t_{psd2}$ |

Note. η : Drive system efficiency

The following shows equations of the linear servo motor thrust and energy.

| Section | Thrust F of linear servo motor [N] | Energy E [J] |
|---------|-----------------------------------------------|----------------------------------------|
| 1) | $F_1 = (M_1 + M_2) \cdot V / t_{psa1} + F_t$ | $E_1 = V / 2 \cdot F_1 \cdot t_{psa1}$ |
| 2) | $F_2 = F_t$ | $E_2 = V \cdot F_2 \cdot t_1$ |
| 3) | $F_3 = -(M_1 + M_2) \cdot V / t_{psd1} + F_t$ | $E_3 = V / 2 \cdot F_3 \cdot t_{psd1}$ |
| 4), 8) | $F_4, F_8 = 0$ | $E_4, E_8 = 0$ (No regeneration) |
| 5) | $F_5 = (M_1 + M_2) \cdot V / t_{psa2} + F_t$ | $E_5 = V / 2 \cdot F_5 \cdot t_{psa2}$ |
| 6) | $F_6 = F_t$ | $E_6 = V \cdot F_6 \cdot t_3$ |
| 7) | $F_7 = -(M_1 + M_2) \cdot V / t_{psd2} + F_t$ | $E_7 = V / 2 \cdot F_7 \cdot t_{psd2}$ |

11. OPTIONS AND PERIPHERAL EQUIPMENT

(2) Losses of servo motor and servo amplifier in regenerative mode

The following table lists the efficiencies and other data of the servo motor and servo amplifier in the regenerative mode.

| Servo amplifier | Inverse efficiency [%] | Capacitor charging energy E_c [J] |
|-----------------|------------------------|-------------------------------------|
| MR-J4W2-22B | 75 | 17 |
| MR-J4W2-44B | 85 | 21 |
| MR-J4W2-77B | 85 | 44 |
| MR-J4W2-1010B | 85 | 44 |
| MR-J4W3-222B | 75 | 21 |
| MR-J4W3-444B | 85 | 31 |

Inverse efficiency (η_m): Efficiency including some efficiencies of the servo motor and servo amplifier when rated (regenerative) torque is generated at rated speed. Efficiency varies with the speed and generated torque. Since the characteristics of the electrolytic capacitor change with time, allow for approximately 10% higher inverse efficiency.

Capacitor charging energy (E_c): Energy charged into the electrolytic capacitor in the servo amplifier

(3) Calculation of regenerative energy per cycle

For example, calculate the regenerative energy in the following operation pattern with 3-axis servo amplifier.

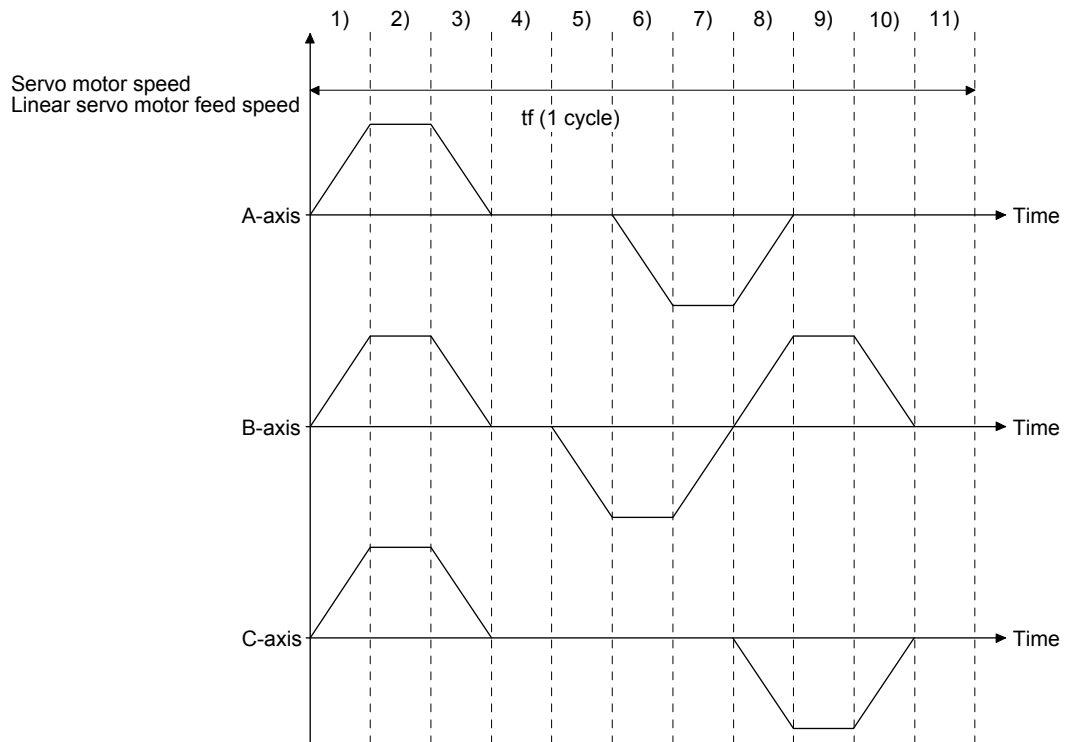

11. OPTIONS AND PERIPHERAL EQUIPMENT

Calculate the energy at different timings in one cycle. Energy is a positive value in power running and a negative value in regeneration. Write down the energy during power running/regeneration with signs in the calculation table as shown below.

| Timing | 1) | 2) | 3) | 4) | 5) | 6) | 7) | 8) | 9) | 10) | 11) |
|--------|-----|-----|-----|-----|-----|-----|-----|-----|-----|------|------|
| A-axis | E1A | E2A | E3A | E4A | E5A | E6A | E7A | E8A | E9A | E10A | E11A |
| B-axis | E1B | E2B | E3B | E4B | E5B | E6B | E7B | E8B | E9B | E10B | E11B |
| C-axis | E1C | E2C | E3C | E4C | E5C | E6C | E7C | E8C | E9C | E10C | E11C |
| Sum | E1 | E2 | E3 | E4 | E5 | E6 | E7 | E8 | E9 | E10 | E11 |

Calculate the energy consumed by the regenerative resistor with the following equation for the calculation results from E1 to E11 with a negative value.

When the absolute value of the value in E1 to E11 is assumed to be E_s : $ER [J] = \eta_m \cdot E_s - E_c$

If ER values are negative at all timings, the regenerative option is not needed. If any of ER values is positive, calculate the energy consumed by the regenerative resistor in one cycle from the time for one cycle and the sum of the positive ER values.

$PR [W] = \text{Sum of the positive ER values} / \text{Operating time (tf) for one cycle}$

Regenerative option is not required when PR is equal to or less than the specification value of the servo amplifier built-in regenerative energy.

11.2.3 Parameter setting

Set [Pr. PA02] according to the option to be used.

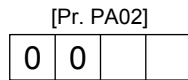

Regenerative option selection
 00: Regenerative option is not used. (Built-in regenerative resistor is used.)
 0B: MR-RB3N
 0D: MR-RB14
 0E: MR-RB34

11. OPTIONS AND PERIPHERAL EQUIPMENT

11.2.4 Connection of regenerative option

| |
|------------------------------------------------------------------|
| POINT |
| ● For the sizes of wires used for wiring, refer to section 11.5. |

The regenerative option generates heat of 100 °C higher than the ambient temperature. Fully consider heat dissipation, installation position, wires used, etc. before installing the option. For wiring, use flame-resistant wires or make the wires flame-resistant and keep them away from the regenerative option. Use twisted wires of up to 5 m for connecting the servo amplifier.

Connect the regenerative option to P+ and C. G3 and G4 are thermal sensor's terminals. Between G3 and G4 is opened when the regenerative option overheats abnormally.

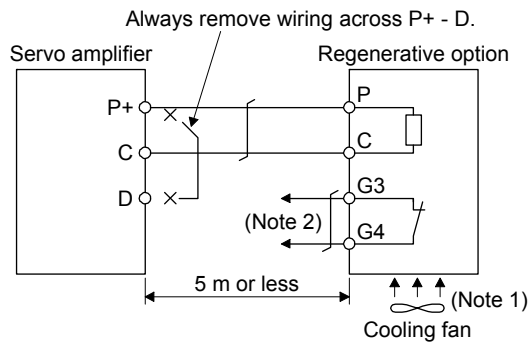

Note 1. When the ambient temperature is more than 55 °C and the regenerative load ratio is more than 60% in MR-RB34 and MR-RB3N, forcefully cool the air with a cooling fan (1.0 m³/min or more, 92 mm × 92 mm). A cooling fan is not required if the ambient temperature is 35 °C or less. (A cooling fan is required for the shaded area in the following graph.)

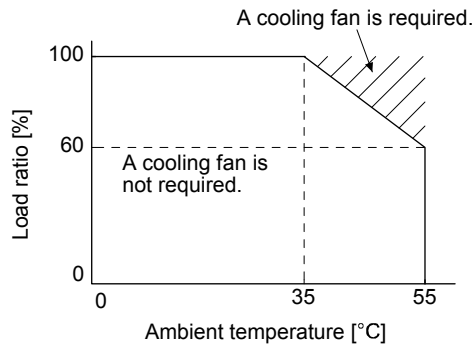

A cooling fan is not required for MR-RB14.

2. Make up a sequence which will switch off the magnetic contactor when abnormal heating occurs.

G3-G4 contact specifications

- Maximum voltage: 120 V AC/DC
- Maximum current: 0.5 A/4.8 V DC
- Maximum capacity: 2.4 VA

11. OPTIONS AND PERIPHERAL EQUIPMENT

11.2.5 Dimensions

(1) MR-RB14

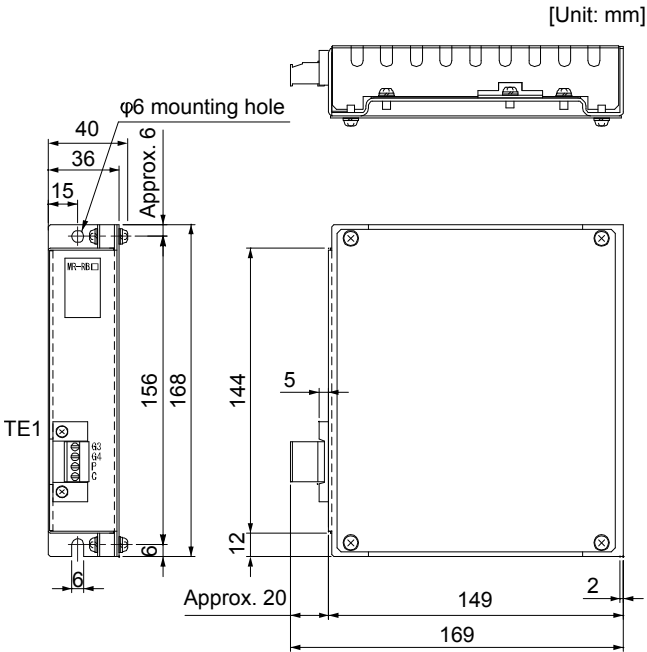

• TE1 terminal

| |
|----|
| G3 |
| G4 |
| P |
| C |

Applicable wire size: 0.2 mm² to 2.5 mm² (AWG 14 to 12)
Tightening torque: 0.5 to 0.6 [N•m]

• Mounting screw
Screw size: M5
Tightening torque: 3.24 [N•m]

Mass: 1.1 [kg]

(2) MR-RB34/MR-RB3N

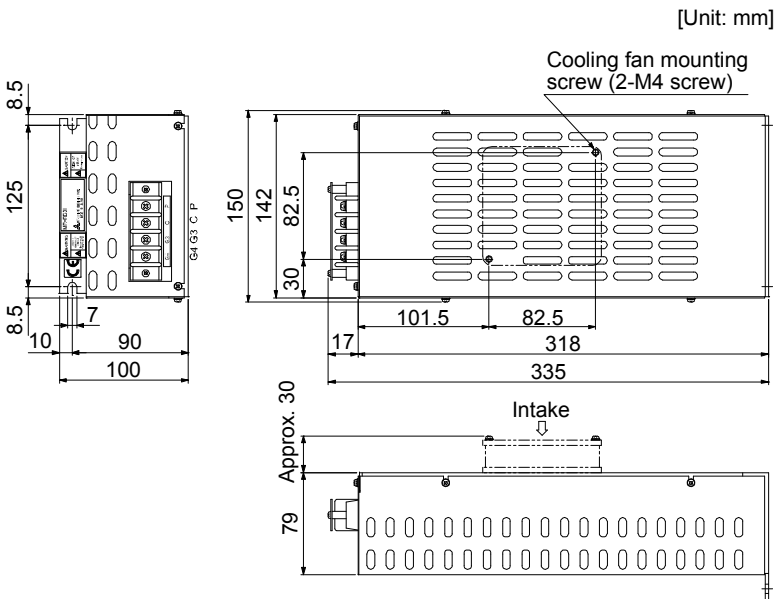

• Terminal block

| |
|----|
| P |
| C |
| G3 |
| G4 |

Terminal screw size: M4
Tightening torque: 1.2 [N•m]

• Mounting screw
Screw size: M6
Tightening torque: 5.4 [N•m]

Mass: 2.9 [kg]

11. OPTIONS AND PERIPHERAL EQUIPMENT

11.3 Battery

| | |
|-------|---------------------------------------------------------------------------------------------|
| POINT | <p>● Refer to app. 2 and 3 for battery transportation and the new EU Battery Directive.</p> |
|-------|---------------------------------------------------------------------------------------------|

This battery is used to construct an absolute position detection system. Refer to chapter 12 for construction of the absolute position detection system.

11.3.1 Selection of battery

The available batteries vary depending on servo amplifiers. Select a required battery.

(1) Applications of the batteries

| Model | Name | Application | Built-in battery |
|----------------|--------------|-------------------------------------------------------------|------------------|
| MR-BAT6V1SET-A | Battery | For absolute position data backup | MR-BAT6V1 |
| MR-BT6VCASE | Battery case | For absolute position data backup of multi-axis servo motor | MR-BAT6V1 |

(2) Combinations of batteries and the servo amplifier

| Model | MR-J4W _ _ B | MR-J4W2-0303B6 |
|----------------|--------------|----------------|
| MR-BAT6V1SET-A | ○ | ○ |
| MR-BT6VCASE | ○ | ○ |

11. OPTIONS AND PERIPHERAL EQUIPMENT

11.3.2 MR-BAT6V1SET-A battery

| POINT |
|------------------------------------------------------------------------------------------------------------------------------------------------------|
| ● Use MR-BAT6V1SET-A for MR-J4W2-0303B6 servo amplifier. The MR-BAT6V1SET-A cannot be used for MR-J4W_-B servo amplifiers other than MR-J4W2-0303B6. |
| ● For the specifications and year and month of manufacture of the built-in MR-BAT6V1 battery, refer to section 11.3.4. |

(1) Parts identification and dimensions

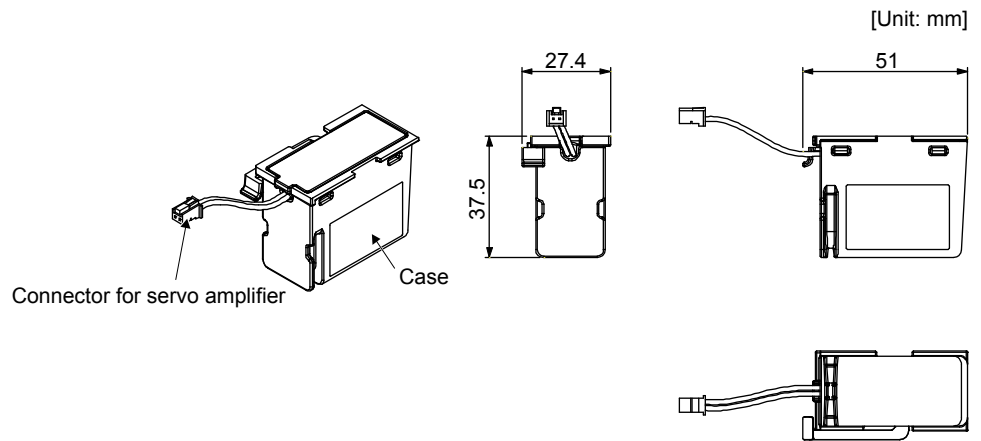

Mass: 55 [g] (including MR-BAT6V1 battery)

(2) Battery mounting Connect as follows.

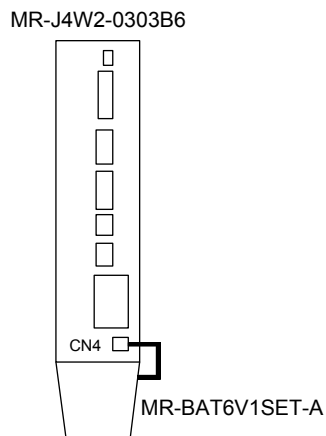

11. OPTIONS AND PERIPHERAL EQUIPMENT

(3) Battery replacement procedure

WARNING

- Before replacing a battery, turn off the main circuit power and wait for 15 minutes or longer until the charge lamp turns off. Then, check the voltage between P+ and N- with a voltage tester or others. Otherwise, an electric shock may occur. In addition, when confirming whether the charge lamp is off or not, always confirm it from the front of the servo amplifier.

CAUTION

- The internal circuits of the servo amplifier may be damaged by static electricity. Always take the following precautions.
 - Ground human body and work bench.
 - Do not touch the conductive areas, such as connector pins and electrical parts, directly by hand.

POINT

- Replacing battery with the control circuit power off will erase the absolute position data.
- Before replacing batteries, check that the new battery is within battery life.

Replace the battery while only control circuit power is on. Replacing battery with the control circuit power on triggers [AL. 9F.1 Low battery]. However, the absolute position data will not be erased.

(a) Installation procedure

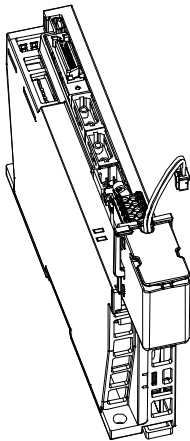

Insert the battery along the rails.

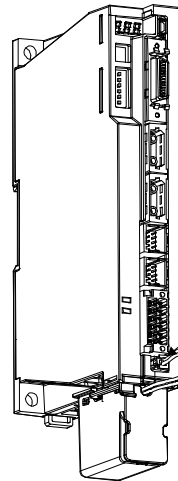

Insert the connector of the battery into CN4.

11. OPTIONS AND PERIPHERAL EQUIPMENT

(b) Removal procedure

 **CAUTION** ● Pulling out the connector of the battery without the lock release lever pressed may damage the CN4 connector of the servo amplifier or the connector of the battery.

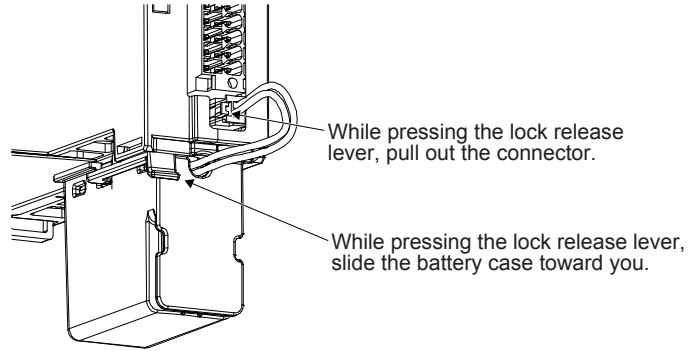

(4) Replacement procedure of the built-in battery

When the MR-BAT6V1SET-A reaches the end of its life, replace the built-in MR-BAT6V1 battery.

1) While pressing the locking part, open the cover.

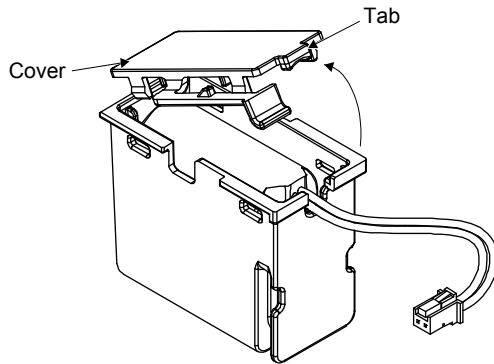

2) Replace the battery with a new MR-BAT6V1 battery.

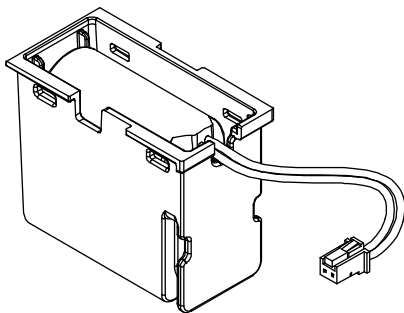

3) Press the cover until it is fixed with the projection of the locking part to close the cover.

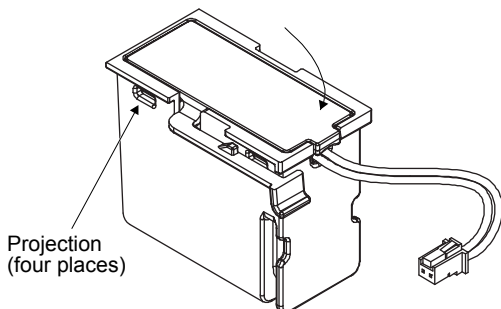

11. OPTIONS AND PERIPHERAL EQUIPMENT

11.3.3 MR-BT6VCASE battery case

| POINT |
|------------------------------------------------------------------------------------------------------------------------------------------------------------------------------------------------------------------------------------------------------------------------------------------------------------------------------------------------------------------------------------------------------------|
| <ul style="list-style-type: none"> ● Use an MR-BT6VCASE for 200 W or more MR-J4W_ _B servo amplifiers. MR-BT6VCASE cannot be used for MR-J4W2-0303B6 servo amplifiers. ● The battery unit consists of an MR-BT6VCASE battery case and five MR-BAT6V1 batteries. ● For the specifications and year and month of manufacture of MR-BAT6V1 battery, refer to section 11.3.4. |

MR-BT6VCASE is a case used for connecting and mounting five MR-BAT6V1 batteries. A battery case does not have any batteries. Please prepare MR-BAT6V1 batteries separately.

(1) The number of connected servo motors

One MR-BT6VCASE holds absolute position data up to eight axes servo motors. For direct drive motors, up to four axes can be connected. Servo motors and direct drive motors in the incremental system are included as the axis Nos. Linear servo motors are not counted as the axis Nos. Refer to the following table for the number of connectable axes of each servo motor.

| Servo motor | Number of axes | | | | | | | | | |
|--------------------|----------------|---|---|---|---|---|---|---|---|--|
| | 0 | 1 | 2 | 3 | 4 | 5 | 6 | 7 | 8 | |
| Rotary servo motor | 0 | 1 | 2 | 3 | 4 | 5 | 6 | 7 | 8 | |
| Direct drive motor | 4 | 4 | 4 | 4 | 4 | 3 | 2 | 1 | 0 | |

(2) Dimensions

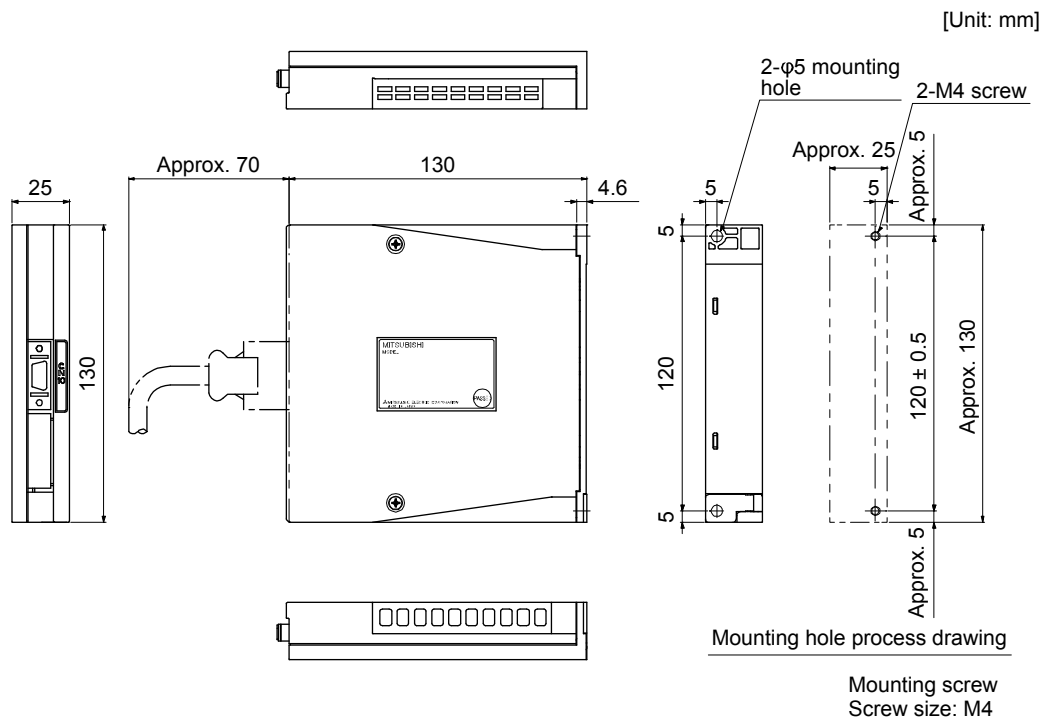

[Mass: 0.18 kg]

11. OPTIONS AND PERIPHERAL EQUIPMENT

(3) Battery mounting

| POINT |
|---------------------------------------------------------------------------------------------------------------------------------------------------------------------------------------------------------------------------------------------------------------------------------------------------------------------------------------------------------------------------------------------------------------------------------------------------------------------------------------|
| <ul style="list-style-type: none"> ● One battery unit can be connected to up to 8-axis servo motors. However, when using direct drive motors, the number of axes of the direct drive motors should be up to 4 axes. Servo motors and direct drive motors in the incremental system are included as the axis Nos. Linear servo motors are not counted as the axis Nos. ● The MR-J4W_ _B servo amplifiers can be combined with MR-J4_ _B(-RJ) servo amplifiers. |

(a) When using 1-axis servo amplifier

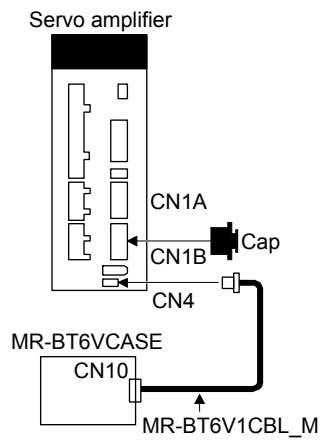

(b) When using up to 8-axis servo amplifiers

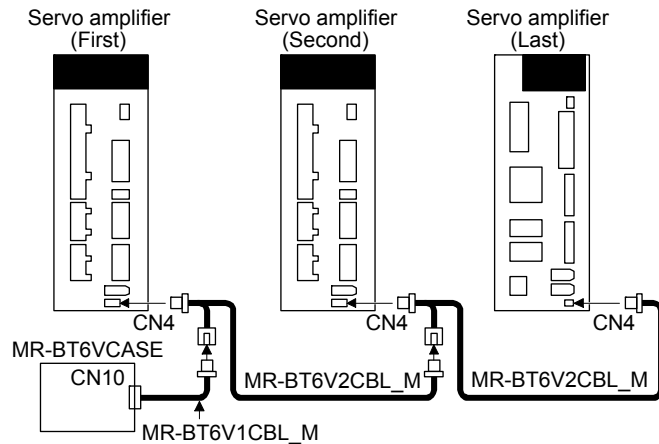

11. OPTIONS AND PERIPHERAL EQUIPMENT

(4) Battery replacement procedure



WARNING

- Before replacing a battery, turn off the main circuit power and wait for 15 minutes or longer until the charge lamp turns off. Then, check the voltage between P+ and N- with a voltage tester or others. Otherwise, an electric shock may occur. In addition, when confirming whether the charge lamp is off or not, always confirm it from the front of the servo amplifier.



CAUTION

- The internal circuits of the servo amplifier may be damaged by static electricity. Always take the following precautions.
 - Ground human body and work bench.
 - Do not touch the conductive areas, such as connector pins and electrical parts, directly by hand.

| POINT |
|-----------------------------------------------------------------------------------------------|
| ● Replacing battery with the control circuit power off will erase the absolute position data. |
| ● Before replacing batteries, check that the new battery is within battery life. |

Replace the battery while only control circuit power is on. Replacing battery with the control circuit power on triggers [AL. 9F.1 Low battery]. However, the absolute position data will not be erased.

11. OPTIONS AND PERIPHERAL EQUIPMENT

(a) Assembling a battery unit

| | | |
|-----------------------------------------------------------------------------------|---------|---------------------------------------------------------------------------------------------------------------------------------------------------------------------------------|
|  | CAUTION | <ul style="list-style-type: none"> ● Do not mount new and old batteries together. ● When you replace a battery, replace all batteries at the same time. |
|-----------------------------------------------------------------------------------|---------|---------------------------------------------------------------------------------------------------------------------------------------------------------------------------------|

| | |
|-------|-----------------------------------------------------------------------------------------------------------------------------|
| POINT | <ul style="list-style-type: none"> ● Always install five MR-BAT6V1 batteries to an MR-BT6VCASE battery case. |
|-------|-----------------------------------------------------------------------------------------------------------------------------|

1) Required items

| Product name | Model | Quantity | Remark |
|--------------|-------------|----------|----------------------------------------------------------------------------------|
| Battery case | MR-BT6VCASE | 1 | MR-BT6VCASE is a case used for connecting and mounting five MR-BAT6V1 batteries. |
| Battery | MR-BAT6V1 | 5 | Lithium battery (primary battery, nominal + 6 V) |

2) Disassembly and assembly of the battery case MR-BT6VCASE

a) Disassembly of the case

MR-BT6VCASE is shipped assembled. To mount MR-BAT6V1 batteries, the case needs to be disassembled.

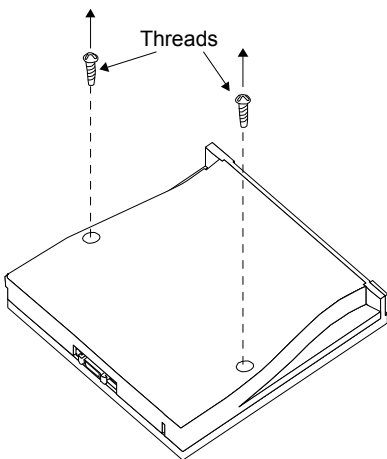

Remove the two screws using a Phillips screwdriver.

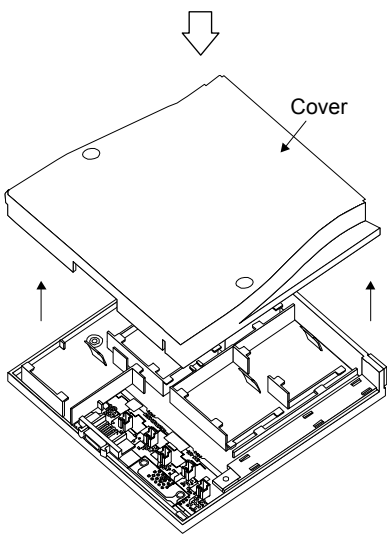

Remove the cover.

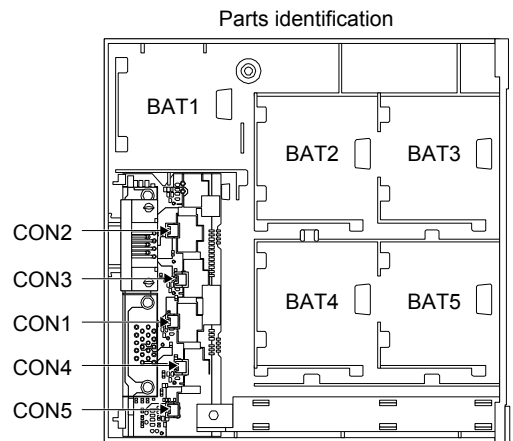

11. OPTIONS AND PERIPHERAL EQUIPMENT

b) Mounting MR-BAT6V1

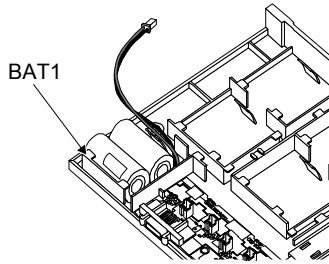

Securely mount an MR-BAT6V1 to the BAT1 holder.

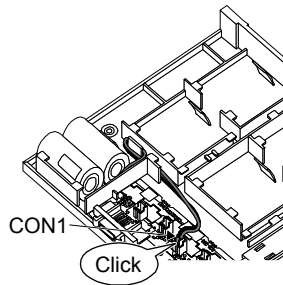

Insert the MR-BAT6V1 connector mounted on BAT1 holder to CON1.

Confirm the click sound at this point.

The connector has to be connected in the right direction.

If the connector is pushed forcefully in the incorrect direction, the connector will break.

Place the MR-BAT6V1 lead wire to the duct designed to store lead wires.

Insert MR-BAT6V1 to the holder in the same procedure in the order from BAT2 to BAT5.

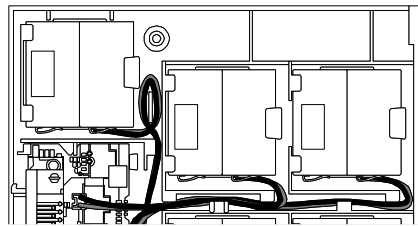

Bring out the lead wire from the space between the ribs, and bend it as shown above to store it in the duct. Connect the lead wire to the connector. Be careful not to get the lead wire caught in the case or other parts.
When the lead wire is damaged, external short circuit may occur, and the battery can become hot.

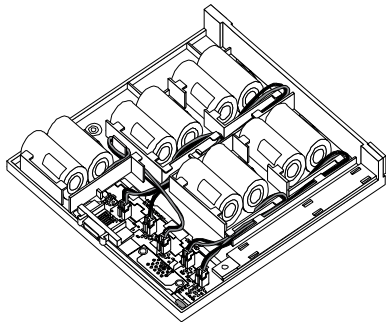

11. OPTIONS AND PERIPHERAL EQUIPMENT

c) Assembly of the case

After all MR-BAT6V1 batteries are mounted, fit the cover and insert screws into the two holes and tighten them. Tightening torque is 0.71 N·m.

POINT

- When assembling the case, be careful not to get the lead wires caught in the fitting parts or the screwing parts.

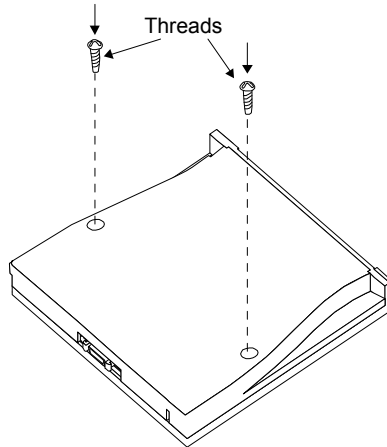

d) Precautions for removal of battery

The connector attached to the MR-BAT6V1 battery has the lock release lever. When removing the connector, pull out the connector while pressing the lock release lever.

3) Battery cable removal

CAUTION

- Pulling out the connector of the MR-BT6V1CBL and the MR-BT6V2CBL without the lock release lever pressed may damage the CN4 connector of the servo amplifier or the connector of the MR-BT6V1CBL or MR-BT6V2CBL.

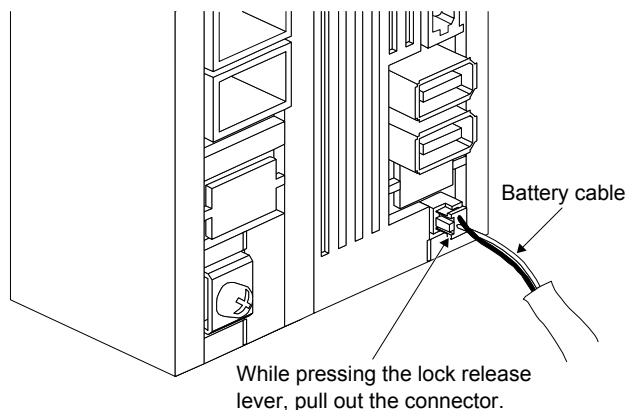

11. OPTIONS AND PERIPHERAL EQUIPMENT

11.3.4 MR-BAT6V1 battery

The MR-BAT6V1 battery is a primary lithium battery for replacing MR-BAT6V1SET-A and MR-BAT6V1SET and a primary lithium battery built-in MR-BT6VCASE. Store the MR-BAT6V1 in the case to use.

The year and month of manufacture of MR-BAT6V1 battery have been described to the rating plate put on an MR-BAT6V1 battery.

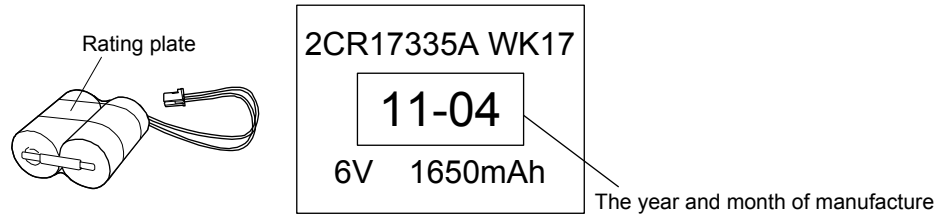

| Item | Description |
|-----------------------------------------|------------------------------------------------------------------------------|
| Battery pack | 2CR17335A (CR17335A × 2 pcs. in series) |
| Nominal voltage [V] | 6 |
| Nominal capacity [mAh] | 1650 |
| Storage temperature [°C] | 0 to 55 |
| Operating temperature [°C] | 0 to 55 |
| Lithium content [g] | 1.2 |
| Mercury content | Less than 1 ppm |
| Dangerous goods class | Not subject to the dangerous goods (Class 9) Refer to app. 2 for details. |
| Operating humidity and storage humidity | 5 %RH to 90 %RH (non-condensing) |
| Battery life (Note) | 5 years from date of manufacture |
| Mass [g] | 34 |

Note. Quality of the batteries degrades by the storage condition. The battery life is 5 years from the production date regardless of the connection status.

11. OPTIONS AND PERIPHERAL EQUIPMENT

11.4 MR Configurator2

MR Configurator2 (SW1DNC-MRC2-_) uses the communication function of the servo amplifier to perform parameter setting changes, graph display, test operation, etc. on a personal computer.

11.4.1 Specifications

| Item | Description |
|------------|----------------------------------------------------------------------------------------------------------------------------------------------------------------------------------------------|
| Project | Create/read/save/delete project, read/write other format, system setting, print |
| Parameter | Parameter setting |
| Monitor | Display all, I/O monitor, graph, ABS data display |
| Diagnosis | Alarm display, alarm onset data, drive recorder, no motor rotation, system configuration, life diagnosis, machine diagnosis, fully closed loop diagnosis (Note 2), linear diagnosis (Note 3) |
| Test mode | Jog mode (Note 4), positioning mode, motor-less operation (Note 1), DO forced output, program operation, test mode information |
| Adjustment | One-touch tuning, tuning, machine analyzer |
| Others | Servo assistant, parameter setting range update, machine unit conversion setting, help display |

- Note
1. The motor-less operation cannot be used in the fully closed loop control mode, linear servo motor control mode, or DD motor control mode.
 2. This is available only in the fully closed loop control mode.
 3. This is available only in the linear servo motor control mode.
 4. This is available in the standard control mode, fully closed loop control mode, and DD motor control mode.

11. OPTIONS AND PERIPHERAL EQUIPMENT

11.4.2 System configuration

(1) Component

To use MR Configurator2 (SW1DNC-MRC2-_), the following components are required in addition to the servo amplifier and servo motor.

| Equipment | Description | |
|-------------------------------------------|-------------------------------------------------------------------------------------------------------------------------------------------------|-----------------------------------------------------------------------------------------------------------------------------------------------------------------------------------------------------------------------------------------------------------------------------------------------------------------------------------------------------------------------------------------------------------------------------------------------------------------------------------------------------------------------------------------------------------------------------------------------------------------------------------------------------------------------------------------------------------------------------------------------------------------------------------------------------------------------------------------------------|
| (Note 1, 2, 3, 4, 5) Personal computer | OS | Microsoft® Windows® 10 Home Microsoft® Windows® 10 Pro Microsoft® Windows® 10 Enterprise Microsoft® Windows® 10 Education Microsoft® Windows® 8.1 Enterprise Microsoft® Windows® 8.1 Pro Microsoft® Windows® 8.1 Microsoft® Windows® 8 Enterprise Microsoft® Windows® 8 Pro Microsoft® Windows® 8 Microsoft® Windows® 7 Enterprise Microsoft® Windows® 7 Ultimate Microsoft® Windows® 7 Professional Microsoft® Windows® 7 Home Premium Microsoft® Windows® 7 Starter Microsoft® Windows Vista® Enterprise Microsoft® Windows Vista® Ultimate Microsoft® Windows Vista® Business Microsoft® Windows Vista® Home Premium Microsoft® Windows Vista® Home Basic Microsoft® Windows® XP Professional, Service Pack3 or later Microsoft® Windows® XP Home Edition, Service Pack3 or later |
| | CPU (recommended) | Desktop personal computer: Intel® Celeron® processor 2.8 GHz or more Laptop personal computer: Intel® Pentium® M processor 1.7 GHz or more |
| | Memory (recommended) | 512 MB or more (for 32-bit OS), 1 GB or more (for 64-bit OS) |
| | Free space on the hard disk | 1 GB or more |
| | Communication interface | USB port |
| Browser | Windows® Internet Explorer® 4.0 or more | |
| Display | One whose resolution is 1024 × 768 or more and that can provide a high color (16 bit) display. Connectable with the above personal computer. | |
| Keyboard | Connectable with the above personal computer. | |
| Mouse | Connectable with the above personal computer. | |
| Printer | Connectable with the above personal computer. | |
| USB cable | MR-J3USBCBL3M | |

Note 1. On some personal computers, MR Configurator2 may not run properly.

2. The following functions cannot be used.

- Windows Program Compatibility mode
- Fast User Switching
- Remote Desktop
- Large Fonts Mode (Display property)
- DPI settings other than 96 DPI (Display property)

For 64-bit operating system, this software is compatible with Windows® 7 and Windows® 8.

3. When Windows® 7 or later is used, the following functions cannot be used.

- Windows XP Mode
- Windows touch

4. When using this software with Windows Vista® or later, log in as a user having USER authority or higher.

5. When Windows® 8 or later is used, the following functions cannot be used.

- Hyper-V
- Modern UI style

11. OPTIONS AND PERIPHERAL EQUIPMENT

(2) Connection with servo amplifier

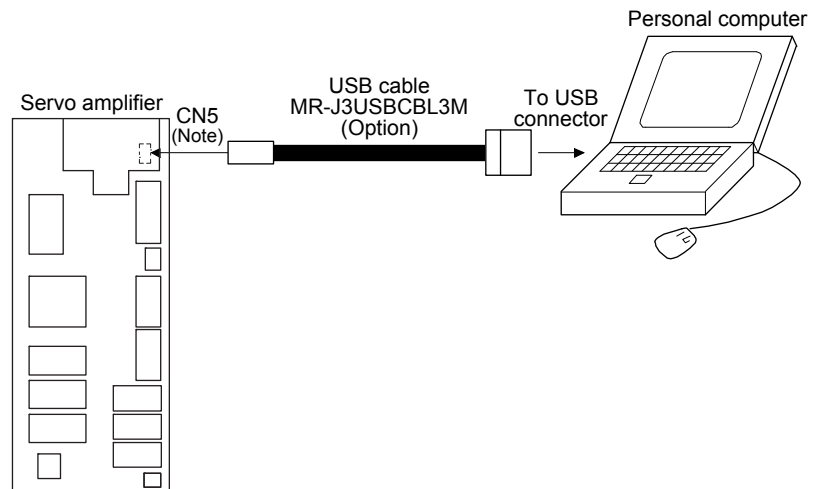

Note. CN5 is located under the display cover.

11.4.3 Precautions for using USB communication function

Note the following to prevent an electric shock and malfunction of the servo amplifier.

(1) Power connection of personal computers

Connect your personal computer with the following procedures.

(a) When you use a personal computer with AC power supply

- 1) When using a personal computer with a three-core power plug or power plug with grounding wire, use a three-pin socket or ground the grounding wire.
- 2) When your personal computer has two-core plug and has no grounding wire, connect the personal computer to the servo amplifier with the following procedures.
 - a) Disconnect the power plug of the personal computer from an AC power socket.
 - b) Check that the power plug was disconnected and connect the device to the servo amplifier.
 - c) Connect the power plug of the personal computer to the AC power socket.

(b) When you use a personal computer with battery

You can use as it is.

(2) Connection with other devices using servo amplifier communication function

When the servo amplifier is charged with electricity due to connection with a personal computer and the charged servo amplifier is connected with other devices, the servo amplifier or the connected devices may malfunction. Connect the servo amplifier and other devices with the following procedures.

- (a) Shut off the power of the device for connecting with the servo amplifier.
- (b) Shut off the power of the servo amplifier which was connected with the personal computer and check the charge lamp is off.
- (c) Connect the device with the servo amplifier.
- (d) Turn on the power of the servo amplifier and the device.

11. OPTIONS AND PERIPHERAL EQUIPMENT

11.5 Selection example of wires

| POINT |
|--------------------------------------------------------------------------------------------------------------------------------------------------------------------------------------------------------------------------------------------------------------------------------------------------------------------------------------------------------------------------------------------------------------------------------------------------------------------------------------------------------------|
| <ul style="list-style-type: none"> ● Refer to section 11.1.2 for SSCNET III cable. ● To comply with the EC/EN/UL/CSA standard, use the wires shown in app. 4 for wiring. To comply with other standards, use a wire that is complied with each standard. ● Selection conditions of wire size are as follows. <ul style="list-style-type: none"> Construction condition: One wire is constructed in the air Wire length: 30 m or less |

(1) Wires for power supply wiring

The following diagram shows the wires used for wiring. Use the wires given in this section or equivalent.

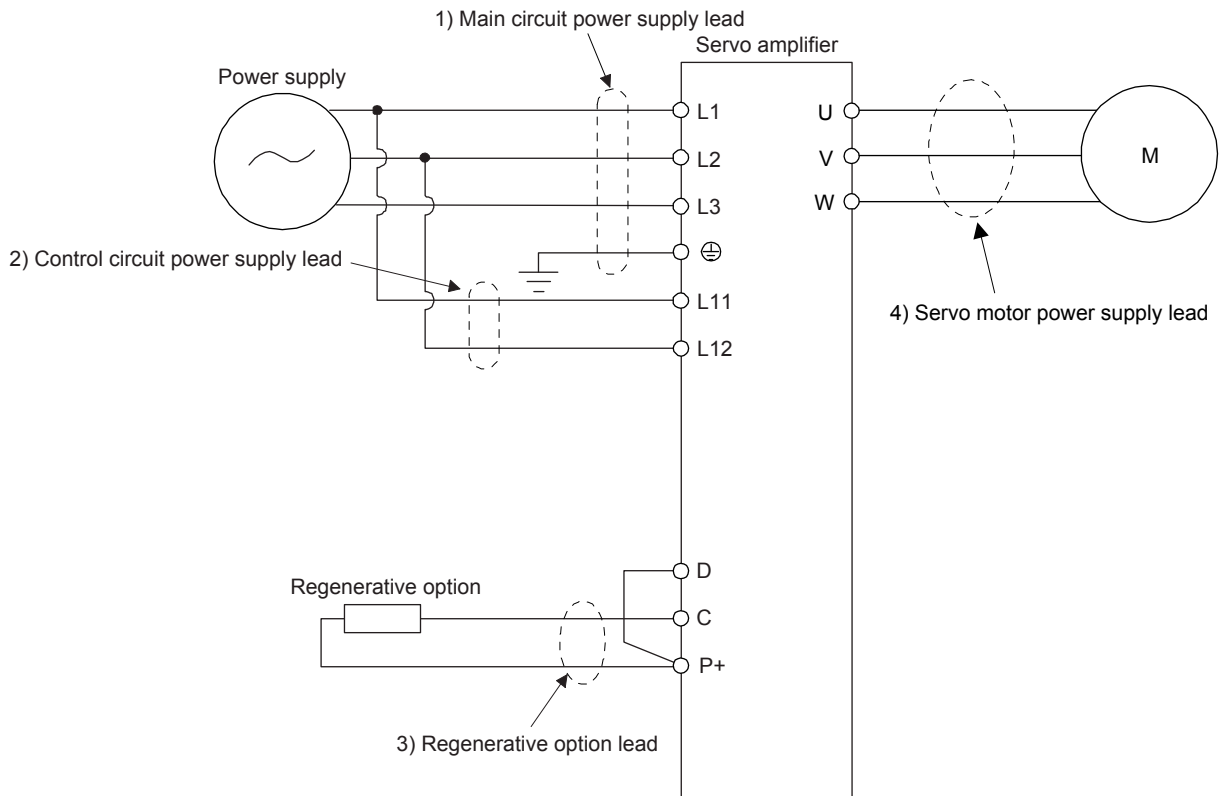

11. OPTIONS AND PERIPHERAL EQUIPMENT

The following table shows the wire size selection example.

Table 11.1 Wire size selection example (HIV wire)

| Servo amplifier | Wires [mm ²] | | | |
|-----------------|---------------------------|------------|-----------|------------------------|
| | 1) L1/L2/L3/⊕ (Note 1) | 2) L11/L21 | 3) P+/C/D | 4) U/V/W/⊕ (Note 2) |
| MR-J4W2-22B | 2 (AWG 14) | | | AWG 18 to 14 |
| MR-J4W2-44B | | | | |
| MR-J4W2-77B | | | | |
| MR-J4W2-1010B | | | | |
| MR-J4W3-222B | | | | |
| MR-J4W3-444B | | | | |

Note 1. Use the crimp terminal specified as below for the PE terminal of the servo amplifier.

Crimp terminal: FVD2-4

Tool: YNT-1614

Manufacturer: JST

Tightening torque: 1.2 [N•m]

2. The wire size shows applicable size of the servo amplifier connector. For wires connecting to the servo motor, refer to "Servo Motor Instruction Manual (Vol. 3)".

11. OPTIONS AND PERIPHERAL EQUIPMENT

11.6 Molded-case circuit breakers, fuses, magnetic contactors

Always use one molded-case circuit breaker and one magnetic contactor with one servo amplifier. When using a fuse instead of the molded-case circuit breaker, use the one having the specifications given in this section.

When using a combination of the rotary servo motor, linear servo motor, or direct drive motor, select a molded-case circuit breaker, a fuse or a magnetic contactor tentatively, assuming one type of the servo motors are used for two or three axes. After the tentative selections are made for all types of the servo motors, use the largest among all molded-case circuit breakers, fuses, or magnetic contactors.

(1) For main circuit power supply

| | |
|--------------------------------------------------------------------------------------------------|--------------------------------------------------------------------------------------------------------------------------------------------------------------------------------------------------------------------------------------------------------------------------------------------|
|  CAUTION | <ul style="list-style-type: none"> ● To prevent the servo amplifier from smoke and a fire, select a molded-case circuit breaker which shuts off with high speed. ● Always use one molded-case circuit breaker and one magnetic contactor with one servo amplifier. |
|--------------------------------------------------------------------------------------------------|--------------------------------------------------------------------------------------------------------------------------------------------------------------------------------------------------------------------------------------------------------------------------------------------|

(a) For MR-J4W2

| Total output of rotary servo motors | Total continuous thrust of linear servo motors | Total output of direct drive motors | Molded-case circuit breaker (Note 5, 6) | | Fuse | | | (Note 2) Magnetic contactor |
|-------------------------------------|------------------------------------------------|-------------------------------------|-----------------------------------------|----------------|-------------------|-------------|----------------|--------------------------------|
| | | | Frame, rated current | Voltage AC [V] | (Note 1) Class | Current [A] | Voltage AC [V] | |
| 300 W or less | | | 50 A frame 5 A (Note 3) | 240 | T | 15 | 300 | S-N10 S-T10 |
| From over 300 W to 600 W | 150 N or less | 100 W or less | 50 A frame 10 A (Note 3) | | | 20 | | |
| From over 600 W to 1 kW | From over 150 N to 300 N | From over 100 W to 252 W | 50 A frame 15 A (Note 3) | | | 20 | | |
| From over 1 kW to 2 kW | From over 300 N to 720 N | From over 252 W to 838 W | 50 A frame 20 A (Note 3) | | | 30 | | |

- Note 1. When using the servo amplifier as an EC/EN/UL/CSA standard compliant product, refer to app. 4.
2. Use a magnetic contactor with an operation delay time (interval between current being applied to the coil until closure of contacts) of 80 ms or less.
3. When not using the servo amplifier as an EC/EN/UL/CSA standard compliant product, molded-case circuit breaker of 30 A frame can be used.
4. S-N18 can be used when auxiliary contact is not required.
5. A molded-case circuit breaker will not change to select regardless of use of a power factor improving AC reactor.
6. Use a molded-case circuit breaker having the operation characteristics equal to or higher than Mitsubishi Electric general-purpose products.

11. OPTIONS AND PERIPHERAL EQUIPMENT

(b) For MR-J4W3

| Total output of rotary servo motors | Total continuous thrust of linear servo motors | Total output of direct drive motors | Molded-case circuit breaker (Note 4, 5) | | Fuse | | | (Note 2) Magnetic contactor | |
|-------------------------------------|------------------------------------------------|-------------------------------------|-----------------------------------------|----------------|----------------|-------------|----------------|-----------------------------|----|
| | | | Frame, rated current | Voltage AC [V] | (Note 1) Class | Current [A] | Voltage AC [V] | | |
| 450 W or less | 150 N or less | / | 50 A frame 10 A (Note 3) | 240 | T | 20 | 300 | S-N10 S-T10 | |
| From over 450 W to 800 W | From over 150 N to 300 N | | 50 A frame 15 A (Note 3) | | | | | | 20 |
| From over 800 W to 1.5 kW | From over 300 N to 450 N | | 50 A frame 20 A (Note 3) | | | | | | 30 |

- Note
1. When using the servo amplifier as an EC/EN/UL/CSA standard compliant product, refer to app. 4.
 2. Use a magnetic contactor with an operation delay time (interval between current being applied to the coil until closure of contacts) of 80 ms or less.
 3. When not using the servo amplifier as an EC/EN/UL/CSA standard compliant product, molded-case circuit breaker of 30 A frame can be used.
 4. A molded-case circuit breaker will not change to select regardless of use of a power factor improving AC reactor.
 5. Use a molded-case circuit breaker having the operation characteristics equal to or higher than Mitsubishi Electric general-purpose products.

The Type E Combination motor controller can also be used instead of a molded-case circuit breaker.

| Servo amplifier | Rated input voltage AC [V] | Input phase | Type E Combination motor controller | | | SCCR [kA] |
|-----------------|----------------------------|-------------|-------------------------------------|----------------------|-----------------------------------|-----------|
| | | | Model | Rated voltage AC [V] | Rated current [A] (Heater design) | |
| MR-J4W2-22B | 200 to 240 | 3-phase | MMP-T32 | 240 | 6.3 | 50 |
| MR-J4W2-44B | | | | | 8 | |
| MR-J4W2-77B | | | | | 13 | |
| MR-J4W2-1010B | | | | | 18 | |
| MR-J4W3-222B | | | | | 8 | |
| MR-J4W3-444B | | | | | 13 | |

(2) For control circuit power supply

When the wiring for the control circuit power supply (L11/L21) is thinner than that for the main circuit power supply (L1/L2/L3), install an overcurrent protection device (molded-case circuit breaker or fuse) to protect the branch circuit.

| Servo amplifier | Molded-case circuit breaker | | Fuse (Class T) | | Fuse (Class K5) | |
|-----------------|-----------------------------|----------------|----------------|----------------|-----------------|----------------|
| | Frame, rated current | Voltage AC [V] | Current [A] | Voltage AC [V] | Current [A] | Voltage AC [V] |
| MR-J4W2-22B | 50 A frame 5 A (Note) | 240 | 1 | 300 | 1 | 250 |
| MR-J4W2-44B | | | | | | |
| MR-J4W2-77B | | | | | | |
| MR-J4W2-1010B | | | | | | |
| MR-J4W3-222B | | | | | | |
| MR-J4W3-444B | | | | | | |

Note. When not using the servo amplifier as an EC/EN/UL/CSA standard compliant product, molded-case circuit breaker of 30 A frame can be used.

11. OPTIONS AND PERIPHERAL EQUIPMENT

11.7 Power factor improving AC reactors

The following shows the advantages of using power factor improving AC reactor.

- It improves the power factor by increasing the form factor of the servo amplifier's input current.
- It decreases the power supply capacity.
- The input power factor is improved to be about 80%.

When using power factor improving reactors for two servo amplifiers or more, be sure to connect a power factor improving reactor to each servo amplifier. If using only one power factor improving reactor, enough improvement effect of phase factor cannot be obtained unless all servo amplifiers are operated.

When using a combination of the rotary servo motor, linear servo motor, or direct drive motor, select a power factor improving AC reactor tentatively, assuming one type of the servo motors are used for 2 or 3 axes.

After the tentative selections are made for all types of the servo motors, use the largest among all power factor improving AC reactors.

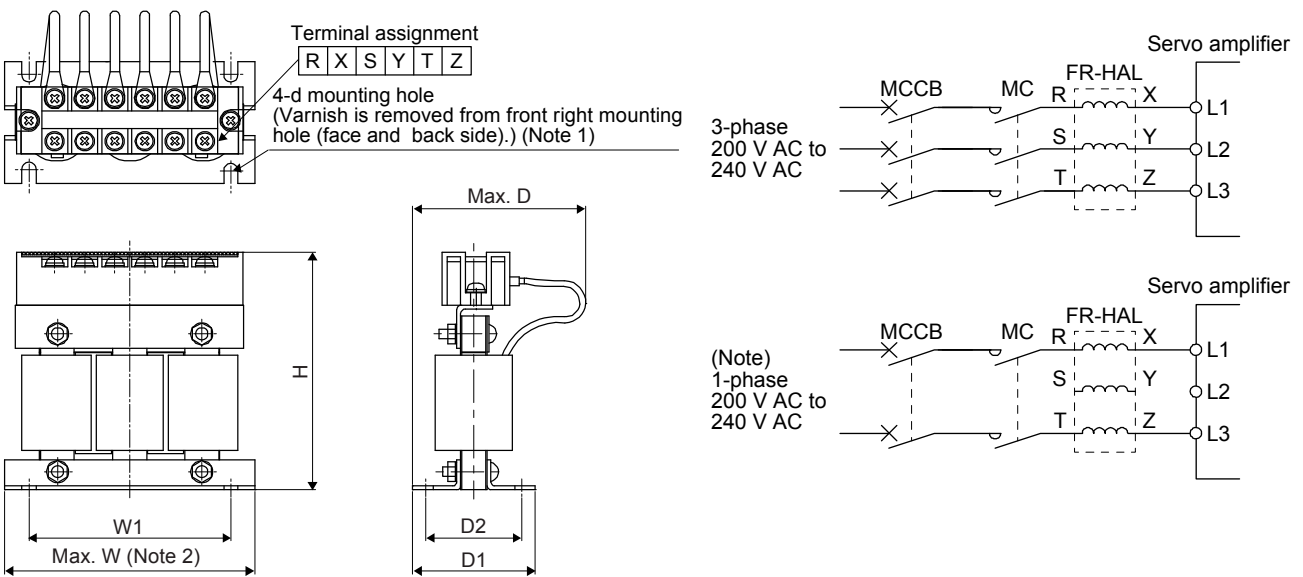

Note 1. Use this for grounding.

Note 2. $W \pm 2$ is applicable for FR-HAL-0.4K to FR-HAL-1.5K.

Note. For 1-phase 200 V AC to 240 V AC, connect the power supply to L1 and L3. Leave L2 open.

11. OPTIONS AND PERIPHERAL EQUIPMENT

(1) For MR-J4W2

| Total output of rotary servo motors | Total continuous thrust of linear servo motors | Total output of direct drive motors | Power factor improving AC reactor |
|-------------------------------------|------------------------------------------------|-------------------------------------|-----------------------------------|
| 450 W or less | 150 N or less | 100 W or less | FR-HAL-0.75K |
| From over 450 W to 600 W | From over 150 N to 240 N | From over 100 W to 377 W | FR-HAL-1.5K |
| From over 600 W to 1 kW | From over 240 N to 300 N | From over 377 W to 545 W | FR-HAL-2.2K |
| From over 1 kW to 20 kW | From over 300 N to 720 N | From over 545 W to 838 W | FR-HAL-3.7K |

(2) For MR-J4W3

| Total output of rotary servo motors | Total continuous thrust of linear servo motors | Total output of direct drive motors | Power factor improving AC reactor |
|-------------------------------------|------------------------------------------------|-------------------------------------|-----------------------------------|
| 450 W or less | 150 N or less | | FR-HAL-0.75K |
| From over 450 W to 600 W | From over 150 N to 240 N | 378 W or less | FR-HAL-1.5K |
| From over 600 W to 1 kW | From over 240 N to 300 N | | FR-HAL-2.2K |
| From over 1 kW to 20 kW | From over 300 N to 450 N | | FR-HAL-3.7K |

(3) Dimensions

| Power factor improving AC reactor | Dimensions [mm] | | | | | | | Terminal size | Mass [kg] |
|-----------------------------------|-----------------|----|-----|------------|----|----|----|---------------|-----------|
| | W | W1 | H | D (Note 1) | D1 | D2 | d | | |
| FR-HAL-0.75K | 104 | 84 | 99 | 74 | 56 | 44 | M5 | M4 | 0.8 |
| FR-HAL-1.5K | 104 | 84 | 99 | 77 | 61 | 50 | M5 | M4 | 1.1 |
| FR-HAL-2.2K | 115 (Note 1) | 40 | 115 | 77 | 71 | 57 | M6 | M4 | 1.5 |
| FR-HAL-3.7K | 115 (Note 1) | 40 | 115 | 83 | 81 | 67 | M6 | M4 | 2.2 |

- Note 1. Maximum dimension. The dimension varies depending on the input/output lines.
 2. Selection conditions of wire size are as follows.
 600 V grade heat-resistant polyvinyl chloride insulated wire (HIV wire)
 Construction condition: One wire is constructed in the air

11.8 Relays (recommended)

The following relays should be used with the interfaces

| Interface | Selection example |
|------------------------------------------------------------------------------|------------------------------------------------------------------------------------------------------------|
| Digital input interface DI-1 Relay used for digital input command signals | To prevent defective contacts, use a relay for small signal (twin contacts). (Ex.) Omron : type G2A, MY |
| Digital output (interface DO-1) Relay used for digital output signals | Small relay with 12 V DC or 24 V DC of rated current 40 mA or less (Ex.) Omron : type MY |

11.9 Noise reduction techniques

Noises are classified into external noises which enter the servo amplifier to cause it to malfunction and those radiated by the servo amplifier to cause peripheral devices to malfunction. Since the servo amplifier is an electronic device which handles small signals, the following general noise reduction techniques are required. Also, the servo amplifier can be a source of noise as its outputs are chopped by high carrier frequencies. If peripheral devices malfunction due to noises produced by the servo amplifier, noise suppression measures must be taken. The measures will vary slightly with the routes of noise transmission.

11. OPTIONS AND PERIPHERAL EQUIPMENT

(1) Noise reduction techniques

(a) General reduction techniques

- Avoid laying power lines (input and output cables) and signal cables side by side or do not bundle them together. Separate power lines from signal cables.
- Use a shielded twisted pair cable for connection with the encoder and for control signal transmission, and connect the external conductor of the cable to the SD terminal.
- Ground the servo amplifier, servo motor, etc. together at one point. (Refer to section 3.11.)

(b) Reduction techniques for external noises that cause the servo amplifier to malfunction

If there are noise sources (such as a magnetic contactor, an electromagnetic brake, and many relays which make a large amount of noise) near the servo amplifier and the servo amplifier may malfunction, the following countermeasures are required.

- Provide surge absorbers on the noise sources to suppress noises.
- Attach data line filters to the signal cables.
- Ground the shields of the encoder connecting cable and the control signal cables with cable clamp fittings.
- Although a surge absorber is built into the servo amplifier, to protect the servo amplifier and other equipment against large exogenous noise and lightning surge, attaching a varistor to the power input section of the equipment is recommended.

(c) Techniques for noises radiated by the servo amplifier that cause peripheral devices to malfunction

Noises produced by the servo amplifier are classified into those radiated from the cables connected to the servo amplifier and its main circuits (input and output circuits), those induced electromagnetically or statically by the signal cables of the peripheral devices located near the main circuit cables, and those transmitted through the power supply cables.

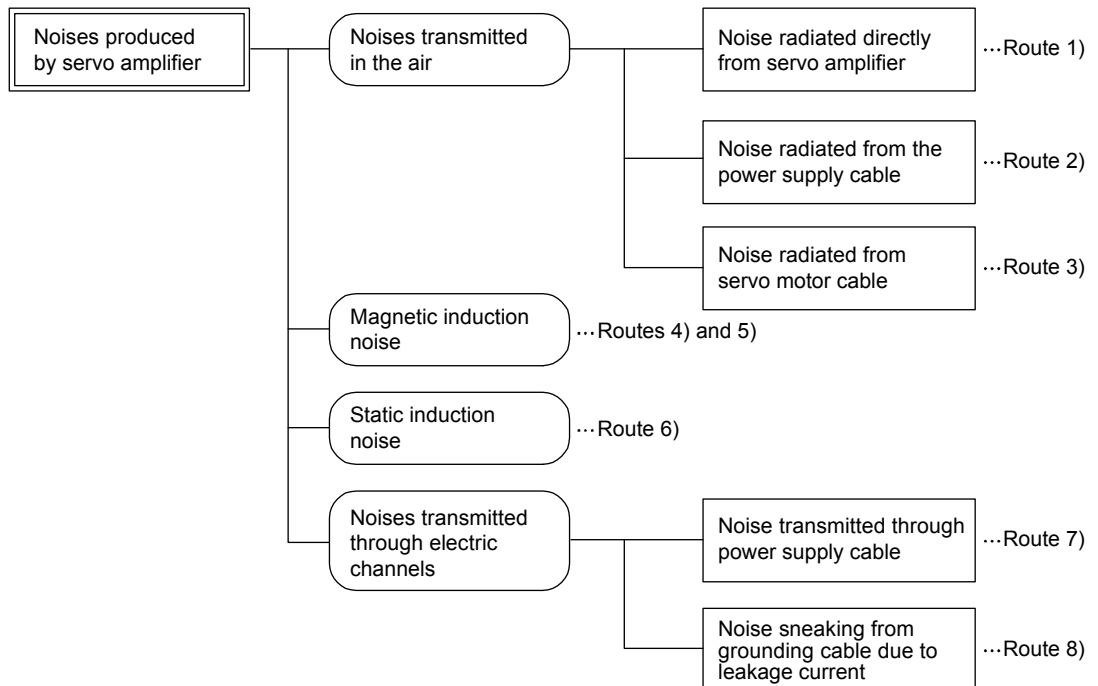

11. OPTIONS AND PERIPHERAL EQUIPMENT

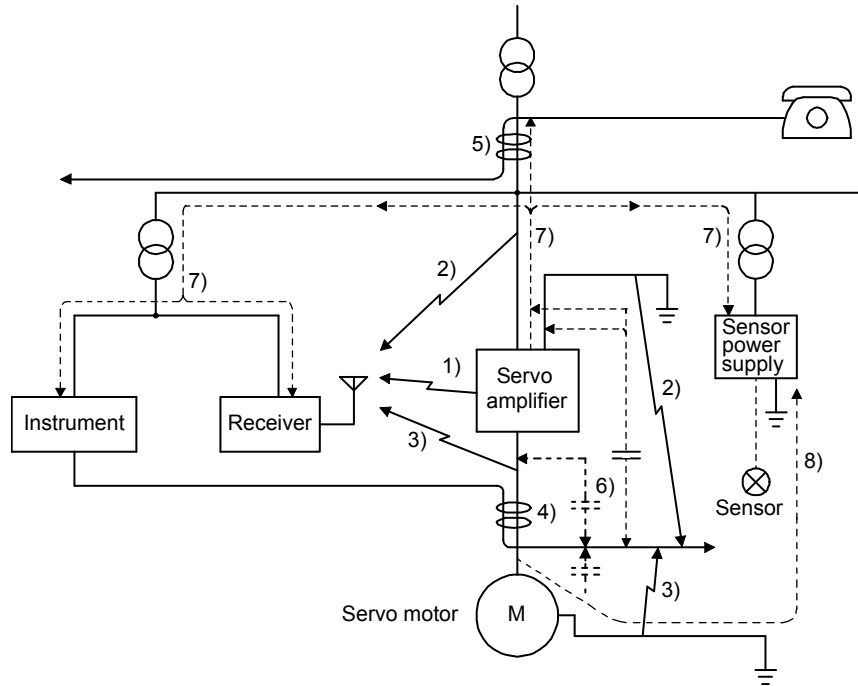

| Noise transmission route | Suppression techniques |
|--------------------------|------------------------------------------------------------------------------------------------------------------------------------------------------------------------------------------------------------------------------------------------------------------------------------------------------------------------------------------------------------------------------------------------------------------------------------------------------------------------------------------------------------------------------------------------------------------------------------------------------------------------------------------------------------------------------------------------------------------------------------------------------------------------------------------------------------------------------------------------------------------------------------------------------------------------------------------------------------------------------------|
| 1) 2) 3) | <p>When measuring instruments, receivers, sensors, etc. which handle weak signals and may malfunction due to noise and/or their signal cables are contained in a cabinet together with the servo amplifier or run near the servo amplifier, such devices may malfunction due to noises transmitted through the air. The following techniques are required.</p> <ol style="list-style-type: none"> 1. Provide maximum clearance between easily affected devices and the servo amplifier. 2. Provide maximum clearance between easily affected signal cables and the I/O cables of the servo amplifier. 3. Avoid wiring the power lines (input/output lines of the servo amplifier) and signal lines side by side or bundling them together. 4. Insert a line noise filter to the I/O cables or a radio noise filter on the input line. 5. Use shielded wires for signal and power lines or put lines in separate metal conduits. |
| 4) 5) 6) | <p>When the power lines and the signal lines are laid side by side or bundled together, magnetic induction noise and static induction noise will be transmitted through the signal cables and malfunction may occur. The following techniques are required.</p> <ol style="list-style-type: none"> 1. Provide maximum clearance between easily affected devices and the servo amplifier. 2. Provide maximum clearance between easily affected signal cables and the I/O cables of the servo amplifier. 3. Avoid wiring the power lines (input/output lines of the servo amplifier) and signal lines side by side or bundling them together. 4. Use shielded wires for signal and power lines or put lines in separate metal conduits. |
| 7) | <p>When the power supply of peripheral devices is connected to the power supply of the servo amplifier system, noises produced by the servo amplifier may be transmitted back through the power supply cable and the devices may malfunction. The following techniques are required.</p> <ol style="list-style-type: none"> 1. Install the radio noise filter (FR-BIF) on the power lines (Input lines) of the servo amplifier. 2. Install the line noise filter (FR-BSF01) on the power lines of the servo amplifier. |
| 8) | <p>If the grounding wires of the peripheral equipment and the servo amplifier make a closed loop circuit, leakage current may flow through, causing the equipment to malfunction. In this case, the malfunction may be prevented by the grounding wires disconnected from the equipment.</p> |

11. OPTIONS AND PERIPHERAL EQUIPMENT

(2) Noise reduction techniques

(a) Data line filter (recommended)

Noise can be prevented by installing a data line filter onto the encoder cable, etc.

For example, ZCAT3035-1330 by TDK, ESD-SR-250 by NEC TOKIN, GRFC-13 by Kitagawa Industries, and E04SRM563218 by SEIWA ELECTRIC are available as data line filters.

As a reference example, the impedance specifications of the ZCAT3035-1330 (TDK) are indicated below. These impedances are reference values and not guaranteed values.

| Impedance [Ω] | |
|------------------------|--------------------|
| 10 MHz to 100 MHz | 100 MHz to 500 MHz |
| 80 | 150 |

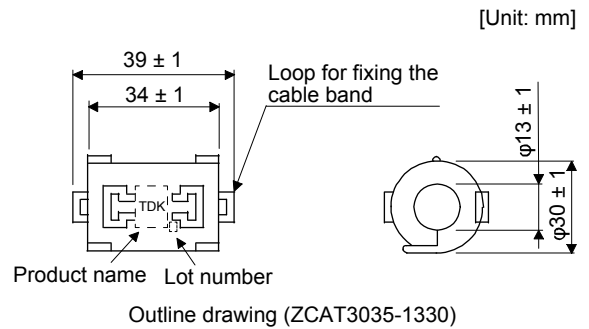

(b) Surge killer (recommended)

Use of a surge killer is recommended for AC relay, magnetic contactor or the like near the servo amplifier. Use the following surge killer or equivalent.

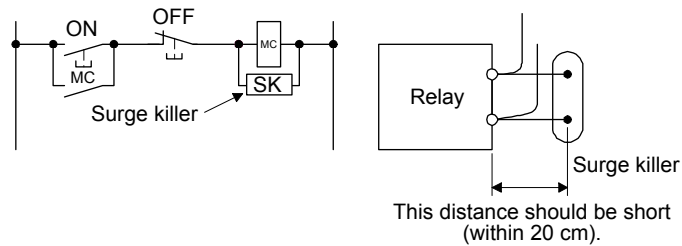

(Ex.) CR-50500 Okaya Electric Industries)

| Rated voltage AC [V] | C [$\mu\text{F} \pm 20\%$] | R [$\Omega \pm 30\%$] | Test voltage |
|----------------------|------------------------------|-------------------------|---------------------------------------------------------------------------------------------------------------|
| 250 | 0.5 | 50 (1/2 W) | Between terminals: 625 V AC, 50 Hz/60 Hz 60 s Between terminal and case: 2000 V AC, 50 Hz/60 Hz 60 s |

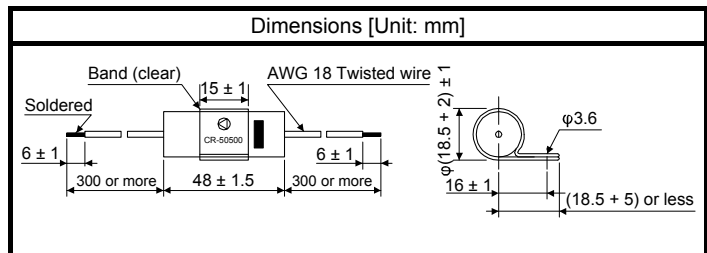

Note that a diode should be installed to a DC relay or the like.

Maximum voltage: Not less than four times the drive voltage of the relay or the like.

Maximum current: Not less than twice the drive current of the relay or the like.

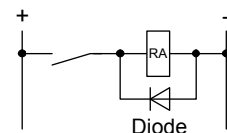

11. OPTIONS AND PERIPHERAL EQUIPMENT

(c) Cable clamp fitting AERSBAN-_SET

Generally, connecting the grounding of the shielded wire to the SD terminal of the connector provides a sufficient effect. However, the effect can be increased when the shielded wire is connected directly to the grounding plate as shown below.

Install the grounding plate near the servo amplifier for the encoder cable. Peel part of the cable sheath to expose the external conductor, and press that part against the grounding plate with the cable clamp.

If the cable is thin, clamp several cables in a bunch. The clamp comes as a set with the grounding plate.

[Unit: mm]

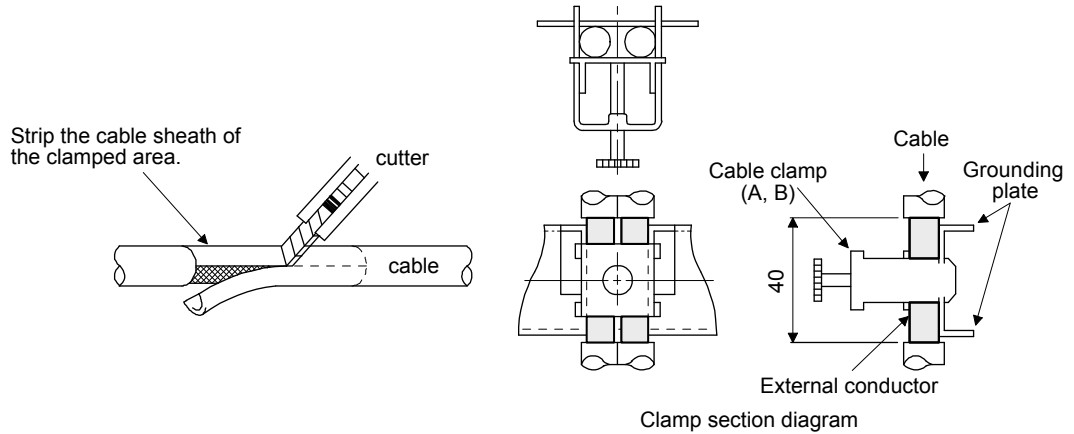

Dimensions

[Unit: mm]

[Unit: mm]

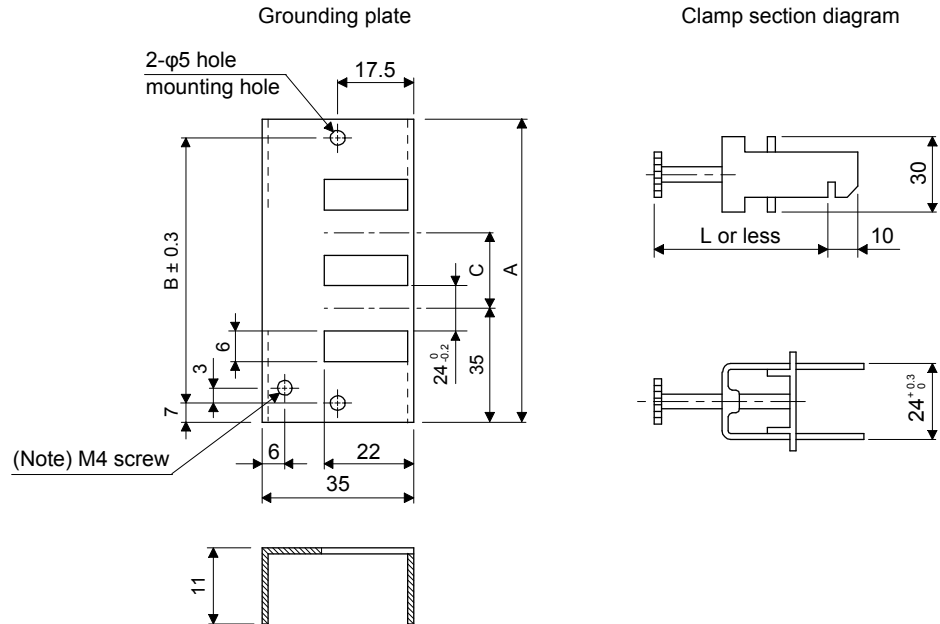

Note. Screw hole for grounding. Connect it to the grounding plate of the cabinet.

| Model | A | B | C | Accessory fittings |
|--------------|-----|----|----|--------------------|
| AERSBAN-DSET | 100 | 86 | 30 | Clamp A: 2 pcs. |
| AERSBAN-ESET | 70 | 56 | | Clamp B: 1 pc. |

| Clamp fitting | L |
|---------------|----|
| A | 70 |
| B | 45 |

11. OPTIONS AND PERIPHERAL EQUIPMENT

(d) Line noise filter (FR-BSF01)

This filter is effective in suppressing noises radiated from the power supply side and output side of the servo amplifier and also in suppressing high-frequency leakage current (0-phase current). It especially affects the noises between 0.5 MHz and 500 MHz band.

| Connection diagram | Dimensions [Unit: mm] |
|---------------------------------------------------------------------------------------------------------------------------------------------------------------------------------------------------------------------------------------------------------------------------------------------------------------------------------------------------------------------------------------------------------------------------------------------------------------------------------------------------------------------------------------------------------------------------------------------------------------------------------------------------------------------------------------------------------------------------------------------------------------------------------------------------------------------------------------------------------------------------------------------------------------------------------------------------------------------------------------------------------------------------------------------------------------------------------------------------------------------------------------------------------|---------------------------------------------------------------------|
| <p>The line noise filters can be mounted on lines of the main power supply (L1/L2/L3) and of the servo motor power (U/V/W). Pass each of the wires through the line noise filter an equal number of times in the same direction. For wires of the main power supply, the effect of the filter rises as the number of passes increases, but generally four passes would be appropriate. For the servo motor power lines, passes must be four times or less. Do not pass the grounding wire through the filter. Otherwise, the effect of the filter will drop.</p> <p>Wind the wires by passing through the filter to satisfy the required number of passes as shown in Example 1. If the wires are too thick to wind, use two or more filters to have the required number of passes as shown in Example 2.</p> <p>Place the line noise filters as close to the servo amplifier as possible for their best performance.</p> <div data-bbox="215 862 718 1064"> <p>Example 1</p> <p>(Number of passes: 4)</p> </div> <div data-bbox="215 1086 718 1355"> <p>Example 2</p> <p>Two filters are used (Total number of passes: 4)</p> </div> | <p>FR-BSF01 (for wire size 3.5 mm² (AWG 12) or less)</p> |

11. OPTIONS AND PERIPHERAL EQUIPMENT

(e) Radio noise filter (FR-BIF)

This filter is effective in suppressing noises radiated from the power supply side of the servo amplifier especially in 10 MHz and lower radio frequency bands. The FR-BIF is designed for the input only.

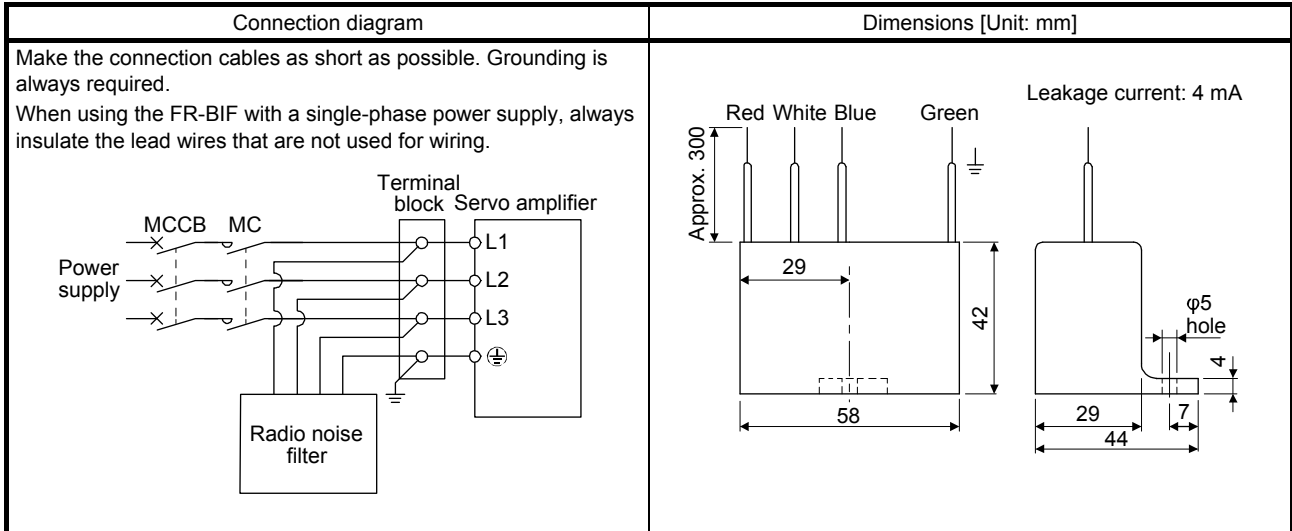

(f) Varistor for input power supply (recommended)

Varistors are effective to prevent exogenous noise and lightning surge from entering the servo amplifier. When using a varistor, connect it between each phase of the input power supply of the equipment. For varistors, the TND20V-431K and TND20V-471K, manufactured by NIPPON CHEMI-CON, are recommended. For detailed specification and usage of the varistors, refer to the manufacturer catalog.

| Varistor | Maximum rated | | | | | Maximum limit voltage | | Static capacity (reference value) | Varistor voltage rating (range) V1 mA |
|-------------|-----------------------------|--------|------------------------|-----------------|-------------------|-----------------------|-----|-----------------------------------|---------------------------------------|
| | Permissible circuit voltage | | Surge current immunity | Energy immunity | Rated pulse power | [A] | [V] | | |
| | AC [Vrms] | DC [V] | 8/20 μ s [A] | 2 ms [J] | [W] | | | [pF] | [V] |
| TND20V-431K | 275 | 350 | 10000/1 time | 195 | 1.0 | 100 | 710 | 1300 | 430 (387 to 473) |
| TND20V-471K | 300 | 385 | 7000/2 times | 215 | | | 775 | 1200 | 470 (423 to 517) |

| Model | [Unit: mm] | | | | | | | |
|-------------|------------|------|------|-----------|-------------|------------|-----------|--|
| | D | H | T | E | L | ϕ d | W | |
| | Max. | Max. | Max. | ± 1.0 | Min. (Note) | ± 0.05 | ± 1.0 | |
| TND20V-431K | 21.5 | 24.5 | 6.4 | 3.3 | 20 | 0.8 | 10.0 | |
| TND20V-471K | | | 6.6 | 3.5 | | | | |

Note. For special purpose items for lead length (L), contact the manufacturer.

11. OPTIONS AND PERIPHERAL EQUIPMENT

11.10 Earth-leakage current breaker

(1) Selection method

High-frequency chopper currents controlled by pulse width modulation flow in the AC servo circuits. Leakage currents containing harmonic contents are larger than those of the motor which is run with a commercial power supply.

Select an earth-leakage current breaker according to the following formula, and ground the servo amplifier, servo motor, etc. securely.

To minimize leakage currents, make the input and output wires as short as possible, and keep a distance of 30 cm or longer between the wires and ground.

$$\text{Rated sensitivity current} \geq 10 \cdot \{I_{g1} + I_{gn} + I_{ga} + K \cdot (I_{g2} \text{ (A-axis)} + I_{gm} \text{ (A-axis)} + I_{g2} \text{ (B-axis)} + I_{gm} \text{ (B-axis)} + I_{g2} \text{ (C-axis)} + I_{gm} \text{ (C-axis)})\} \text{ [mA]} \dots \dots \dots (11.1)$$

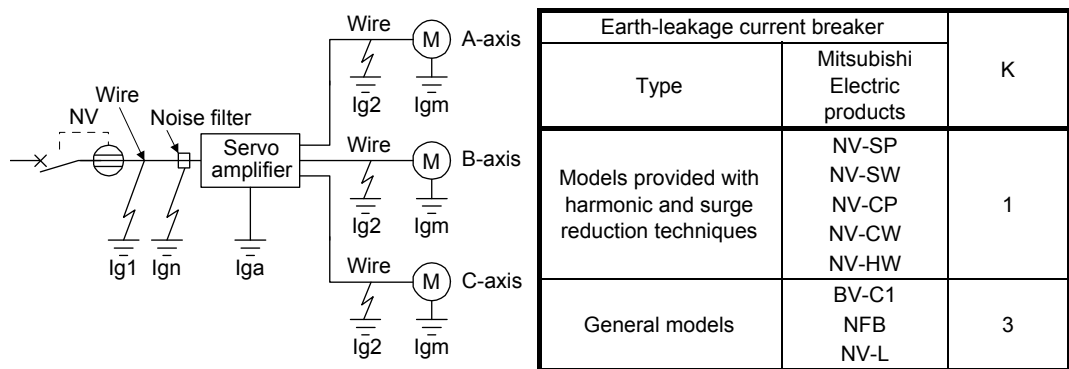

I_{g1} : Leakage current on the electric channel from the earth-leakage current breaker to the input

I_{g2} terminals of the servo amplifier (Found from Fig. 11.1.)

I_{gn} : Leakage current on the electric channel from the output terminals of the servo amplifier to the servo motor (Found from Fig. 11.1.)

I_{gm} : Leakage current when a filter is connected to the input side (4.4 mA per one FR-BIF)

I_{ga} : Leakage current of the servo amplifier (Found from table 11.3.)

I_{gm} : Leakage current of the servo motor (Found from table 11.2.)

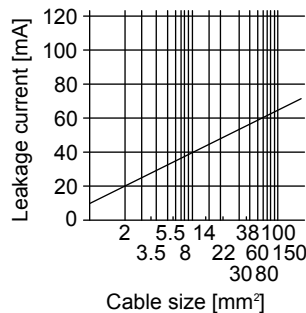

Fig. 11.1 Leakage current example (I_{g1} , I_{g2}) for CV cable run in metal conduit

Table 11.2 Servo motor's leakage current example (I_{gm})

| Servo motor power [kW] | Leakage current [mA] |
|------------------------|----------------------|
| 0.05 to 1 | 0.1 |

11. OPTIONS AND PERIPHERAL EQUIPMENT

Table 11.3 Servo amplifier's leakage current example (Iga)

| Servo amplifier | Leakage current [mA] |
|--------------------------------------------------------------|----------------------|
| MR-J4W2-22B MR-J4W2-44B | 0.1 |
| MR-J4W2-77B MR-J4W2-1010B MR-J4W3-222B MR-J4W3-444B | 0.15 |

Table 11.4 Earth-leakage current breaker selection example

| Servo amplifier | Rated sensitivity current of earth-leakage current breaker [mA] |
|------------------------------------------------------------|-----------------------------------------------------------------|
| MR-J4W2-22B MR-J4W2-44B MR-J4W2-77B MR-J4W2-1010B | 15 |
| MR-J4W3-222B MR-J4W3-444B | 30 |

11. OPTIONS AND PERIPHERAL EQUIPMENT

(2) Selection example

Indicated below is an example of selecting an earth-leakage current breaker under the following conditions.

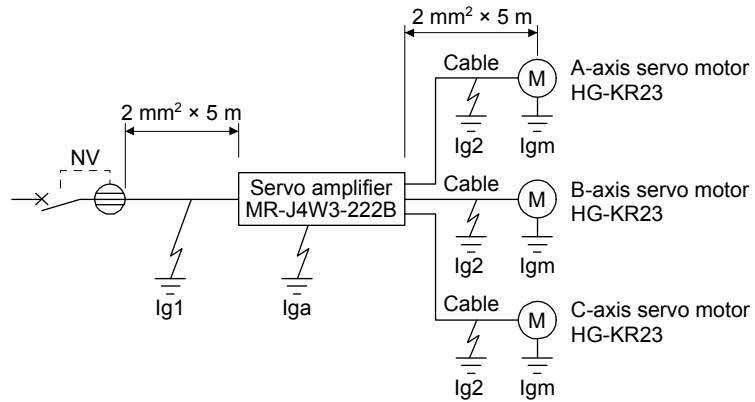

Use an earth-leakage current breaker designed for suppressing harmonics/surges.
Find the terms of equation (11.1) from the diagram.

$$I_{g1} = 20 \cdot \frac{5}{1000} = 0.1 \text{ [mA]}$$

$$I_{g2} = 20 \cdot \frac{5}{1000} = 0.1 \text{ [mA]}$$

$$I_{gn} = 0 \text{ (not used)}$$

$$I_{ga} = 0.15 \text{ [mA]}$$

$$I_{gm} = 0.1 \text{ [mA]}$$

Insert these values in equation (11.1).

$$I_g \geq 10 \cdot \{0.1 + 0 + 0.15 + 1 \cdot (0.1 + 0.1 + 0.1 + 0.1 + 0.1 + 0.1)\} \\ \geq 8.5 \text{ [mA]}$$

According to the result of calculation, use an earth-leakage current breaker having the rated sensitivity current (I_g) of 8.5 mA or more.

An earth-leakage current breaker having I_g of 15 mA is used with the NV-SP/SW/CP/CW/HW series.

11. OPTIONS AND PERIPHERAL EQUIPMENT

11.11 EMC filter (recommended)

| POINT |
|--------------------------------------------------------------------------------------------------------------------------------------------------------------------------------|
| <ul style="list-style-type: none"> ● For when multiple servo amplifiers are connected to one EMC filter, refer to section 6.4 of "EMC Installation Guidelines". |

It is recommended that one of the following filters be used to comply with EN standard's EMC directive. Some EMC filters have large in leakage current.

(1) Combination with the servo amplifier

| Servo amplifier | Recommended filter (Soshin Electric) | | | Mass [kg] |
|----------------------------------------------|--------------------------------------|-------------------|---------------------|-----------|
| | Model | Rated current [A] | Rated voltage [VAC] | |
| MR-J4W2-22B MR-J4W2-44B MR-J4W3-222B | HF3010A-UN (Note) | 10 | 250 | 5 |
| MR-J4W2-77B MR-J4W2-1010B MR-J4W3-444B | HF3010A-UN (Note) | 30 | | |

Note. To use any of these EMC filters, the surge protector RSPD-500-U4 (Okaya Electric Industries) is required.

(2) Connection example

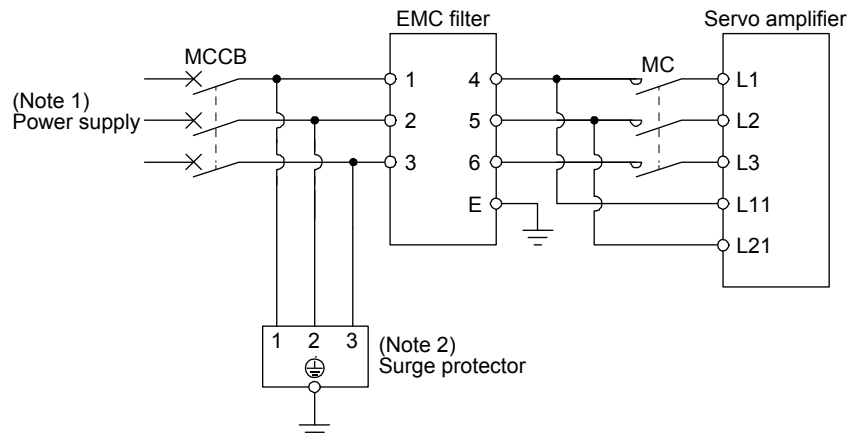

- Note 1. Refer to section 1.3 for the power supply specification.
 Note 2. The example is when a surge protector is connected.

11. OPTIONS AND PERIPHERAL EQUIPMENT

- (3) Dimensions
 - (a) EMC filter
 - HF3010A-UN

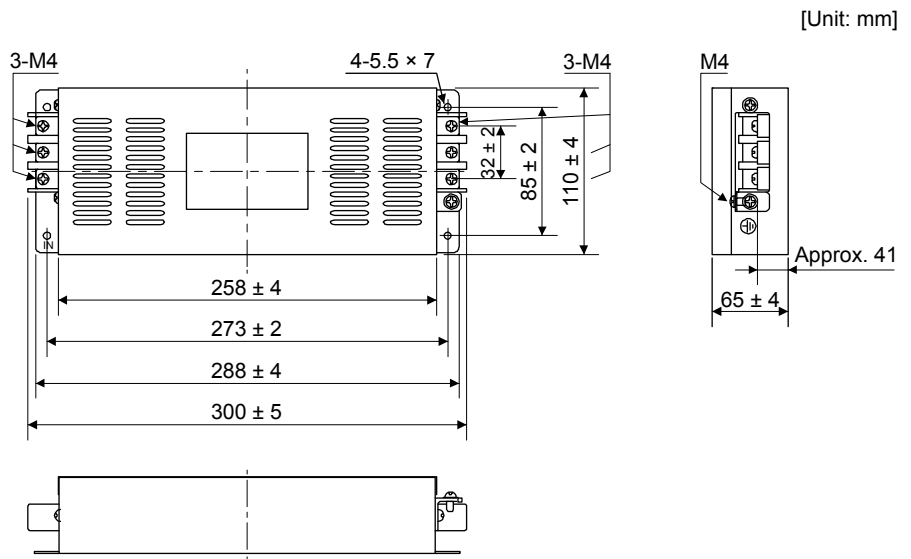

HF3030A-UN

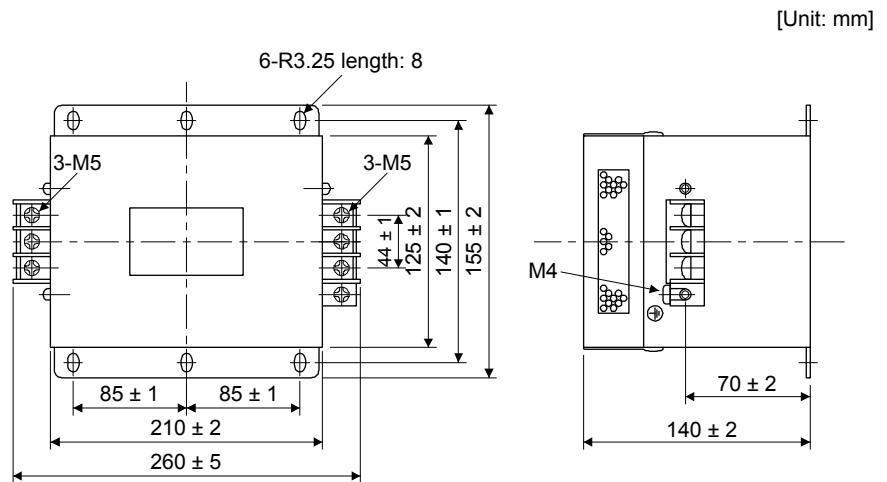

11. OPTIONS AND PERIPHERAL EQUIPMENT

(b) Surge protector

RSPD-250-U4

[Unit: mm]

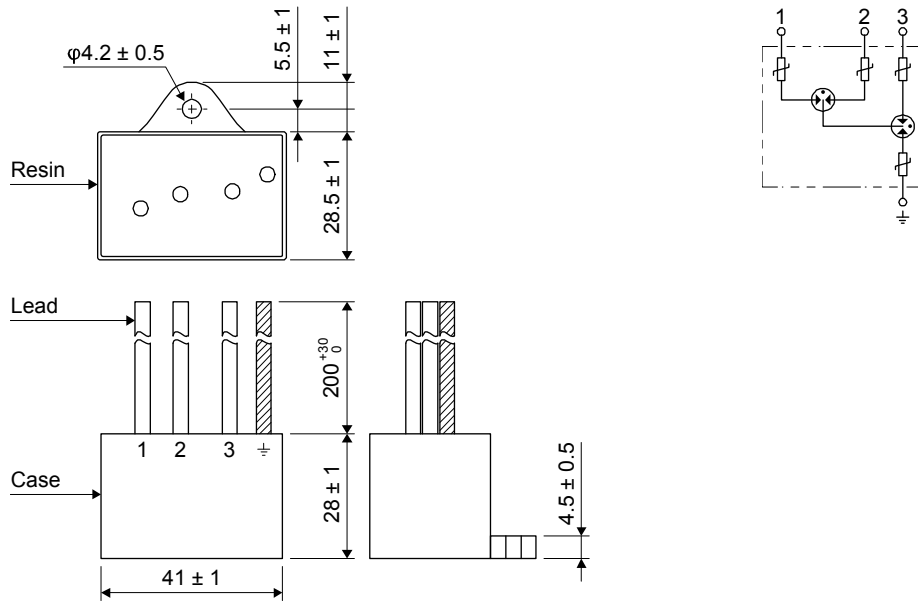

11. OPTIONS AND PERIPHERAL EQUIPMENT

11.12 Junction terminal block MR-TB26A

(1) Usage

Always use the junction terminal block (MR-TB26A) with the option cable (MR-TBNATBL_M) as a set. To use a junction terminal block, mount it to the DIN rail.

MR - T B N A T B L 0 5 M

Cable length
05: 0.5 m
1: 1 m

Terminal numbers on a junction terminal block correspond with the pin numbers on the CN3 connector of a servo amplifier. The terminal symbol S is for the shield.

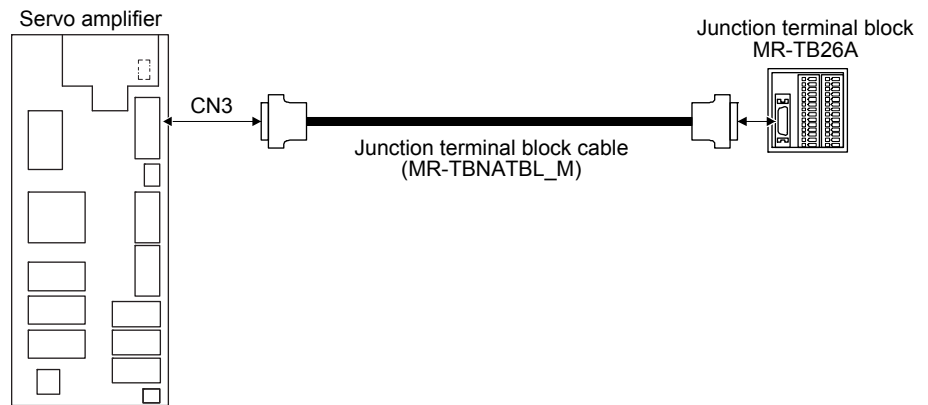

Ground the junction terminal block cable using the S terminal of the junction terminal block.

(2) Specifications

| Junction terminal block | | MR-TB26A |
|-------------------------|-------------------|----------------------------------------------------------------|
| Item | | |
| Rating | | 32 V AC/DC 0.5 A |
| Usable cables | Stranded wire | 0.08 mm ² to 1.5 mm ² (AWG 28 to 14) |
| | Solid wire | φ0.32 mm to 1.2 mm |
| | Wire insulator OD | φ3.4 mm or less |
| Tool | | 210-619 (WAGO) or equivalent 210-119SB (WAGO) or equivalent |
| Stripped length | | 5 mm to 6 mm |

11. OPTIONS AND PERIPHERAL EQUIPMENT

(3) Dimensions

[Unit: mm]

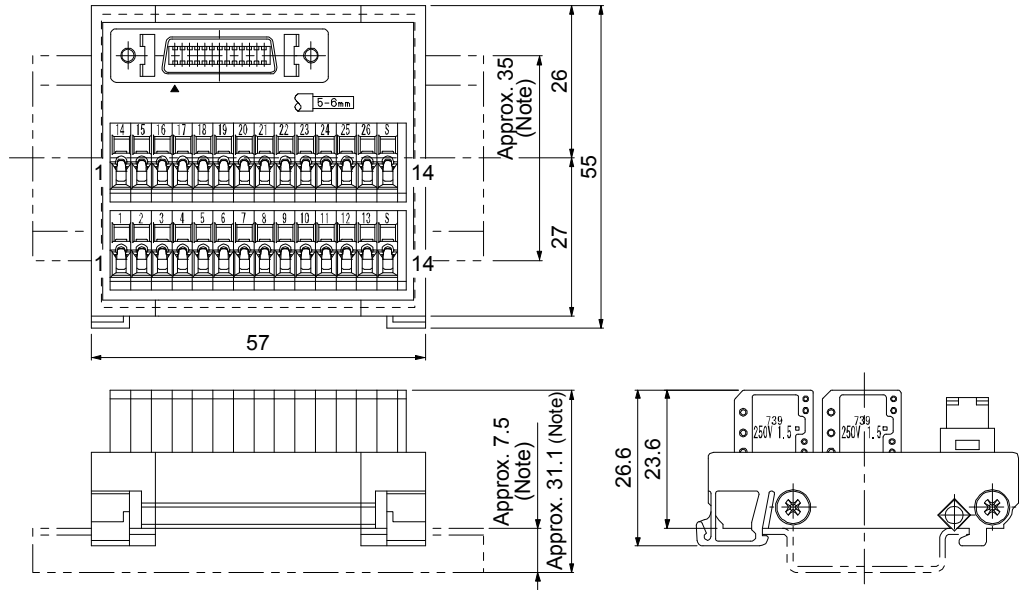

Note. Values in parenthesis are the sizes when installed with a 35 mm DIN rail.

12. ABSOLUTE POSITION DETECTION SYSTEM

12. ABSOLUTE POSITION DETECTION SYSTEM

⚠ CAUTION

- If [AL. 25 Absolute position erased] or [AL. E3 Absolute position counter warning] has occurred, always perform home position setting again. Otherwise, it may cause an unexpected operation.
- If [AL. 25], [AL. 92], or [AL. 9F] occurs due to such as short circuit of the battery, the MR-BAT6V1 battery can become hot. Use the MR-BAT6V1 battery with care to prevent getting burnt.

POINT

- Refer to section 11.3 for the replacement procedure of the battery.
- Disconnecting the encoder cable will erase the absolute position data. After disconnecting the encoder cable, always execute home position setting and then positioning operation.

12.1 Summary

12.1.1 Features

For normal operation, the encoder consists of a detector designed to detect a position within one revolution and a cumulative revolution counter designed to detect the number of revolutions.

The absolute position detection system always detects the absolute position of the machine and keeps it battery-backed, independently of whether the servo system controller power is on or off. Therefore, once home position return is made at the time of machine installation, home position return is not needed when power is switched on thereafter.

Even at a power failure or a malfunction, the system can be easily restored.

12.1.2 Structure

The following shows a configuration of the absolute position detection system. Refer to section 11.3 for each battery connection.

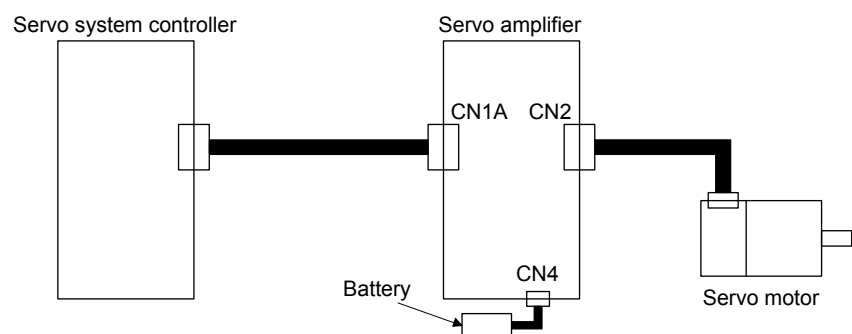

12.1.3 Parameter setting

Set " _ _ _ 1" in [Pr. PA03] to enable the absolute position detection system.

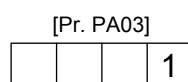

Absolute position detection system selection
 0: Disabled (used in incremental system)
 1: Enabled (used in absolute position detection system)

12. ABSOLUTE POSITION DETECTION SYSTEM

12.1.4 Confirmation of absolute position detection data

You can check the absolute position data with MR Configurator2. Choose "Monitor" and "ABS Data Display" to open the absolute position data display screen.



12. ABSOLUTE POSITION DETECTION SYSTEM

12.2 Battery

12.2.1 Using MR-BAT6V1SET battery (only for MR-J4W2-0303B6)

(1) Configuration diagram

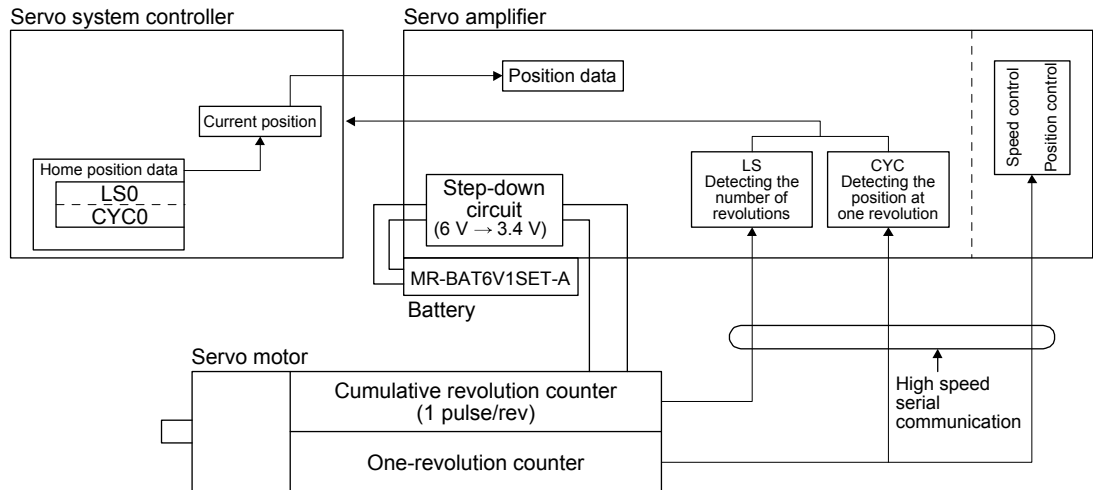

(2) Specifications

(a) Specification list

| Item | Description |
|----------------------------------------------------|-----------------------------------------------------------------------------------------------------------------------------------------------------------------------------------------------------------------|
| System | Electronic battery backup type |
| Maximum revolution range | Home position ± 32767 rev. |
| (Note 1) Maximum speed at power failure [r/min] | 500 |
| (Note 2) Battery backup time | Approximately 10,000 hours/2 axes (equipment power supply: off, ambient temperature: 20 °C) (Note 3) Approximately 14,500 hours/2 axes (power-on time ratio: 25%, ambient temperature: 20 °C) (Note 3) |

- Note 1. Maximum speed available when the shaft is rotated by external force at the time of power failure or the like.
- Note 2. The data-holding time by the battery using MR-BAT6V1SET-A. Replace the batteries within three years since the operation start regardless of the power supply of the servo amplifier on/off.
If the battery is used out of specification, [AL. 25 Absolute position erased] may occur.
- Note 3. Even if absolute position detection system is used only with one axis, the battery backup time will be the same.

12. ABSOLUTE POSITION DETECTION SYSTEM

12.2.2 Using MR-BT6VCASE battery case

| POINT |
|-------------------------------------------------------------------------------|
| ● One MR-BT6VCASE holds absolute position data up to eight axes servo motors. |
| ● Always install five MR-BAT6V1 batteries to an MR-BT6VCASE. |

(1) Configuration diagram

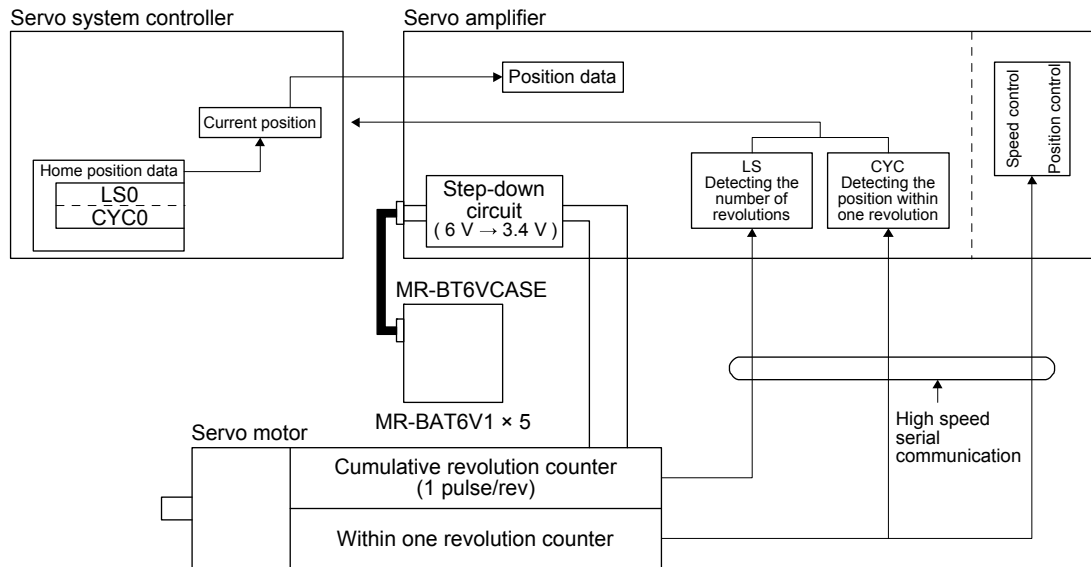

(2) Specification list

| Item | Description | |
|-------------------------------------------------|--------------------------------|------------------------------------------------------------------------------------------------------------------------------------------------------------------------------------------------------------------------------------------------------------------------------------------------------------------|
| System | Electronic battery backup type | |
| Maximum revolution range | Home position ± 32767 rev. | |
| Maximum speed at power failure [r/min] (Note 1) | Rotary servo motor | 6000 (only when acceleration time until 6000 r/min is 0.2 s or more) |
| | Direct drive motor | 500 (only when acceleration time until 500 r/min is 0.1 s or more) |
| Battery backup time (Note 2) | Rotary servo motor | Approximately 40,000 hours/2 axes or less, 30,000 hours/3 axes, or 10,000 hours/8 axes (equipment power supply: off, ambient temperature: 20 °C) Approximately 55,000 hours/2 axes or less, 38,000 hours/3 axes, or 15,000 hours/8 axes (power-on time ratio: 25%, ambient temperature: 20 °C) (Note 3) |
| | Direct drive motor | Approximately 10,000 hours/2 axes or less, 7,000 hours/3 axes, or 5,000 hours/4 axes (equipment power supply: off, ambient temperature: 20 °C) Approximately 15,000 hours/2 axes or less, 13,000 hours/3 axes, or 10,000 hours/4 axes (power-on time ratio: 25%, ambient temperature: 20 °C) (Note 3) |

- Note 1. Maximum speed available when the shaft is rotated by external force at the time of power failure or the like. Also, if power is switched on at the servo motor speed of 3000 r/min or higher, position mismatch may occur due to external force or the like.
- Note 2. The data-holding time by the battery using five MR-BAT6V1s. The battery life varies depending on the number of axes (including axis for using in the incremental system). Replace the batteries within three years since the operation start regardless of the power supply of the servo amplifier on/off. If the battery is used out of specification, [AL. 25 Absolute position erased] may occur.
- Note 3. The power-on time ratio 25% is equivalent to 8 hours power on for a weekday and off for a weekend.

13. USING STO FUNCTION

13. USING STO FUNCTION

| POINT |
|------------------------------------------------------------------------------------------------------------------------------|
| ● In the case of STO function of this servo amplifier, energies to servo motor are interrupted in all axes at the same time. |
| ● In the torque control mode, the forced stop deceleration function is not available. |
| ● The MR-J4W2-0303B6 servo amplifier is not compatible with the STO function. |

13.1 Introduction

This section provides the cautions of the STO function.

13.1.1 Summary

This servo amplifier complies with the following safety standards.

- ISO/EN ISO 13849-1 Category 3 PL e
- IEC 61508 SIL 3
- IEC/EN 61800-5-2
- IEC/EN 62061 SIL CL3

13.1.2 Terms related to safety

The STO function shuts down energy to servo motors, thus removing torque. This function electronically cuts off power supply in the servo amplifier.

The purpose of this function is as follows.

- (1) Uncontrolled stop according to stop category 0 of IEC/EN 60204-1
- (2) Preventing unexpected start-up

13.1.3 Cautions

The following basic safety notes must be read carefully and fully in order to prevent injury to persons or damage to property.

Only qualified personnel are authorized to install, start-up, repair, or service the machines in which these components are installed.

They must be familiar with all applicable local regulations and laws in which machines with these components are installed, particularly the standards mentioned in this manual.

The staff responsible for this work must be given express permission from the company to perform start-up, programming, configuration, and maintenance of the machine in accordance with the safety standards.

| | |
|----------------------------------------------------------------------------------------------------|-----------------------------------------------------------------------------------------------------------------------------------------------------------------------------------|
|  WARNING | ● Improper installation of the safety related components or systems may cause improper operation in which safety is not assured, and may result in severe injuries or even death. |
|----------------------------------------------------------------------------------------------------|-----------------------------------------------------------------------------------------------------------------------------------------------------------------------------------|

Protective Measures

- This servo amplifier satisfies the Safe Torque Off (STO) function described in IEC/EN 61800-5-2 by preventing the energy supply from the servo amplifier to the servo motor. If an external force acts upon the drive axis, additional safety measures, such as brakes or counterbalances must be used.

13. USING STO FUNCTION

13.1.4 Residual risks of the STO function

Machine manufacturers are responsible for all risk evaluations and all associated residual risks. Below are residual risks associated with the STO function. Mitsubishi Electric is not liable for any damages or injuries caused by these risks.

- (1) The STO function disables energy supply to the servo motor by electrical shut-off. The function does not mechanically disconnect electricity from the motor. Therefore, it cannot prevent exposure to electric shock. To prevent an electric shock, install a magnetic contactor or a molded-case circuit breaker to the main circuit power supply (L1/L2/L3) of the servo amplifier.
- (2) The STO function disables energy supply to the servo motor by electrical shut-off. It does not guarantee the stop control or the deceleration control of the servo motor.
- (3) For proper installation, wiring, and adjustment, thoroughly read the manual of each individual safety related component.
- (4) In the safety circuit, use components that are confirmed safe or meet the required safety standards.
- (5) The STO function does not guarantee that the drive part of the servo motor will not rotate due to external or other forces.
- (6) Safety is not assured until safety-related components of the system are completely installed or adjusted.
- (7) When replacing this servo amplifier, confirm that the model name of servo amplifiers are exactly the same as those being replaced. Once installed, make sure to verify the performance of the functions before commissioning the system.
- (8) Perform all risk assessments to the machine or the whole system.
- (9) To prevent accumulation of malfunctions, perform function checks at regular intervals based on the risk assessments of the machine or the system. Regardless of the system safety level, malfunction checks should be performed at least once per year.
- (10) If the upper and lower power modules in the servo amplifier are shorted and damaged simultaneously, the servo motor may make a half revolution at a maximum. For a linear servo motor, the primary side will move a distance of pole pitch.
- (11) The STO input signals (STO1 and STO2) must be supplied from one power source. Otherwise, the STO function may not function properly due to a sneak current, failing to bring the STO shut-off state.
- (12) For the STO I/O signals of the STO function, supply power by using a safety extra low voltage (SELV) power supply with the reinforced insulation.

13. USING STO FUNCTION

13.1.5 Specifications

(1) Specifications

| Item | Specifications |
|----------------------------------------------------------------|------------------------------------------------------------------------------------|
| Functional safety | STO (IEC/EN 61800-5-2) |
| Safety performance (Certification standards) (Note 2) | EN ISO 13849-1 Category 3 PL e, IEC 61508 SIL 3, EN 62061 SIL CL3, EN 61800-5-2 |
| Mean time to dangerous failure (MTTFd) | MTTFd ≥ 100 [years] (314a) |
| Diagnostic converge (DC) | DC = Medium, 97.6 [%] |
| Average probability of dangerous failures per hour (PFH) [1/h] | 6.4 × 10 ⁻⁹ |
| Number of on/off times of STO | 1,000,000 times |
| CE marking | LVD: EN 61800-5-1 EMC: EN 61800-3 MD: EN ISO 13849-1, EN 61800-5-2, EN 62061 |

- Note 1. This is the value required by safety standards.
 Note 2. The safety level depends on the setting value of [Pr. PF18 STO diagnosis error detection time] and whether STO input diagnosis by TOFB output is performed or not. For details, refer to the Function column of [Pr. PF18] in section 5.2.6.

(2) Function block diagram (STO function)

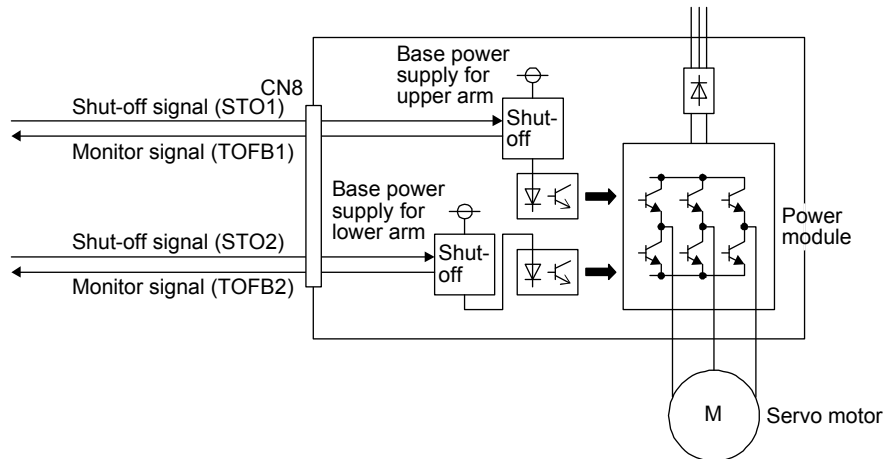

(3) Operation sequence (STO function)

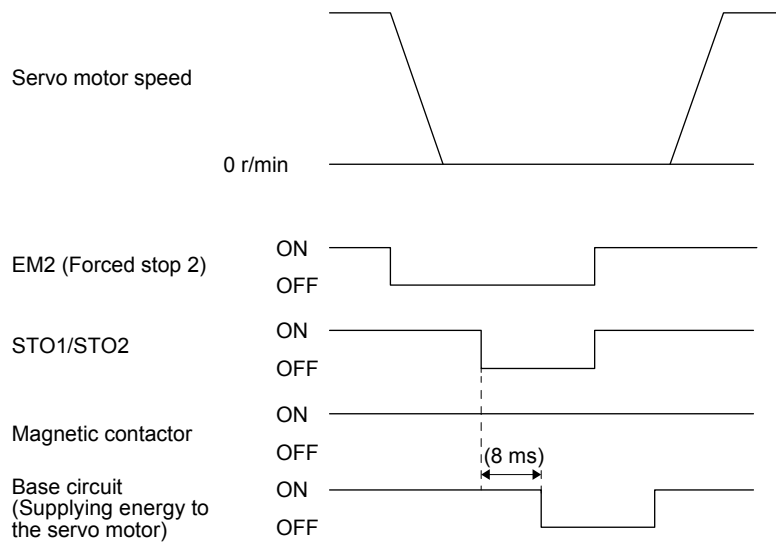

13. USING STO FUNCTION

13.1.6 Maintenance

This servo amplifier has alarms and warnings for maintenance that supports the Drive safety function. (Refer to chapter 8.)

13.2 STO I/O signal connector (CN8) and signal layouts

13.2.1 Signal layouts

POINT
● The pin assignment of the connectors is as viewed from the cable connector wiring section.

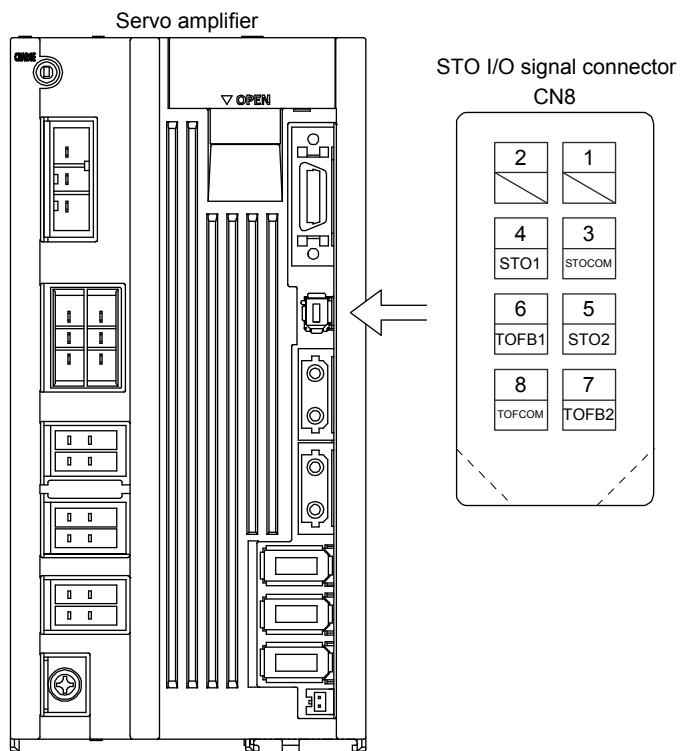

13. USING STO FUNCTION

13.2.2 Signal (device) explanations

(1) I/O device

| Signal name | Connector pin No. | Description | I/O division |
|-------------|-------------------|-------------------------------------------------------------------------------------------------------------------------------------------------------------------------------------------------------------------------------------------------------------------------------------------------------|--------------|
| STOCOM | CN8-3 | Common terminal for input signal of STO1 and STO2 | DI-1 |
| STO1 | CN8-4 | Inputs STO state 1. STO state (base shut-off): Open between STO1 and STOCOM. STO release state (in driving): Close between STO1 and STOCOM. Be sure to turn off STO1 after the servo motor stops by the servo-off state or with forced stop deceleration by turning off EM2 (Forced stop 2). | DI-1 |
| STO2 | CN8-5 | Inputs STO state 2. STO state (base shut-off): Open between STO2 and STOCOM. STO release state (in driving): Close between STO2 and STOCOM. Be sure to turn off STO2 after the servo motor stops by the servo-off state or with forced stop deceleration by turning off EM2 (Forced stop 2). | DI-1 |
| TOFCOM | CN8-8 | Common terminal for monitor output signal in STO state | DO-1 |
| TOFB1 | CN8-6 | Monitor output signal in STO1 state STO state (base shut-off): Between TOFB1 and TOFCOM is closed. STO release state (in driving): Between TOFB1 and TOFCOM is opened. | DO-1 |
| TOFB2 | CN8-7 | Monitor output signal in STO2 state STO state (base shut-off): Between TOFB2 and TOFCOM is closed. STO release state (in driving): Between TOFB2 and TOFCOM is opened. | DO-1 |

(2) Signals and STO state

The following table shows the TOFB and STO states when the power is on in normal state and STO1 and STO2 are on (closed) or off (opened).

| Input signal | | State | | |
|--------------|------|-----------------------------------------------------|-----------------------------------------------------|----------------------------------------------------------------------|
| STO1 | STO2 | Between TOFB1 and TOFCOM (Monitoring STO1 state) | Between TOFB2 and TOFCOM (Monitoring STO2 state) | Between TOFB1 and TOFB2 (Monitoring STO state of servo amplifier) |
| Off | Off | On: STO state (base circuit shut-off) | On: STO state (base circuit shut-off) | On: STO state (base circuit shut-off) |
| Off | On | On: STO state (base circuit shut-off) | Off: STO release state | Off: STO state (base circuit shut-off) |
| On | Off | Off: STO release state | On: STO state (base circuit shut-off) | Off: STO state (base circuit shut-off) |
| On | On | Off: STO release state | Off: STO release state | Off: STO release state |

(3) Test pulse of STO input signal

Set the test pulse off time inputted from outside to 1 ms or less.

13.2.3 How to pull out the STO cable

The following shows how to pull out the STO cable from the CN8 connector of the servo amplifier.

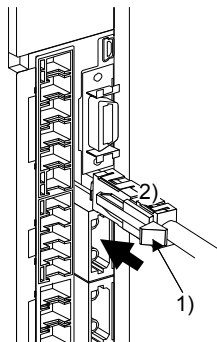

While pressing knob 1) of the STO cable plug in the direction of the arrow, pull out the plug 2).
(This figure shows the MR-J4-_B_(-RJ) servo amplifier. This procedure also applies to the MR-J4W_ _B servo amplifier.)

13. USING STO FUNCTION

13.3 Connection example

| POINT | |
|-------|-------------------------------------------------------------------------------------------------------------------------------------------------------------------------------------------------------------------------------------------------------------------------------------------|
| ● | Turn off STO (STO1 and STO2) after the servo motor stops by the servo off state or with forced stop deceleration by turning off EM2 (Forced stop 2). Configure an external sequence that has the timings shown as below using an external device such as the MR-J3-D05 safety logic unit. |
| | |
| ● | If STO is turned off during operation, the servo motor is in dynamic brake stop (stop category 0), and [AL. 63 STO timing error] will occur. |

13.3.1 Connection example for CN8 connector

This servo amplifier is equipped with the connector (CN8) in accordance with the STO function. When this connector is used with a certified external safety relay, power to the motor can be safely removed and unexpected restart can be prevented. The safety relay used should meet the applicable safety standards and have forcibly guided or mirror contacts for the purpose of error detection.

In addition, the MR-J3-D05 safety logic unit can be used instead of a safety relay for implementation of various safety standards. Refer to app. 5 for details.

The following diagram is for source interface. For sink interface, refer to section 13.4.1.

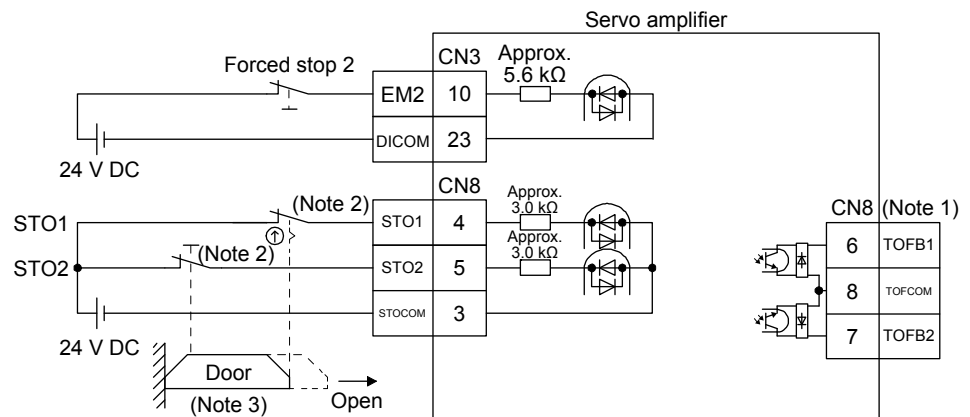

- Note 1. By using TOFB, whether the servo is in the STO state can be confirmed. For connection examples, refer to section 13.3.2 to 13.3.4. The safety level depends on the setting value of [Pr. PF18 STO diagnosis error detection time] and whether STO input diagnosis by TOFB output is performed or not. For details, refer to the Function column of [Pr. PF18] in section 5.2.6.
- Note 2. When using the STO function, turn off STO1 and STO2 at the same time. Turn off STO1 and STO2 after the servo motor stops by the servo off state or with forced stop deceleration by turning off EM2 (Forced stop 2).
- Note 3. Configure the interlock circuit so that the door is open after the servo motor is stopped.

13. USING STO FUNCTION

13.3.2 External I/O signal connection example using an MR-J3-D05 safety logic unit

POINT

● This connection is for source interface. For the other I/O signals, refer to the connection examples in section 3.2.2.

(1) Connection example

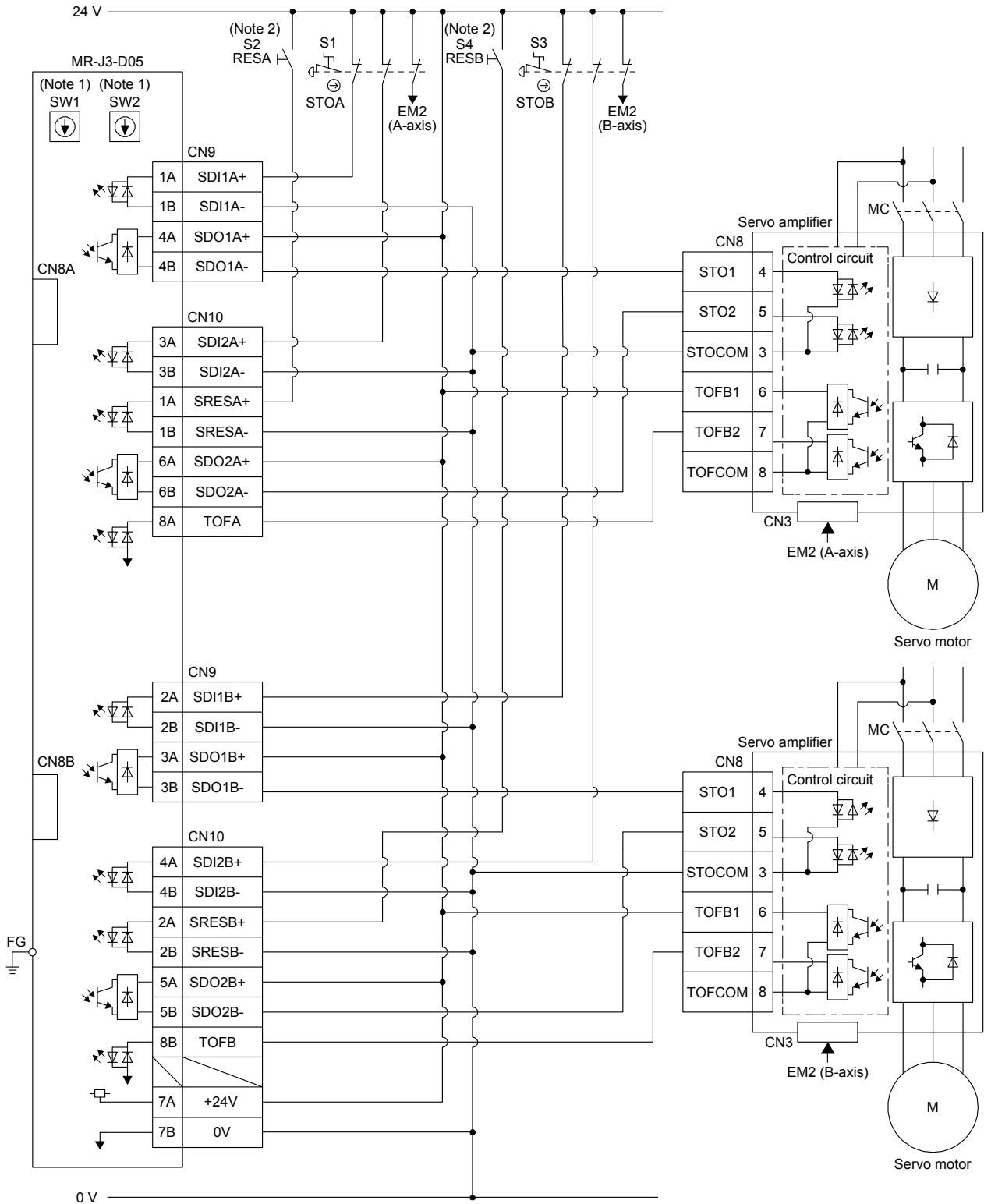

13. USING STO FUNCTION

- Note
1. Set the delay time of STO output with SW1 and SW2. These switches are located where denoted from the front panel.
 2. To release the STO state (base circuit shut-off), turn RESA and RESB on and turn them off.

(2) Basic operation example

The switch status of STOA is input to SDI2A+ of MR-J3-D05, and then it will be input to STO1 and STO2 of the servo amplifier via SDO1A and SDO2A of MR-J3-D05.

The switch status of STOB is input to SDI2B+ of MR-J3-D05, and then it will be input to STO1 and STO2 of the servo amplifier via SDO1B and SDO2B of MR-J3-D05.

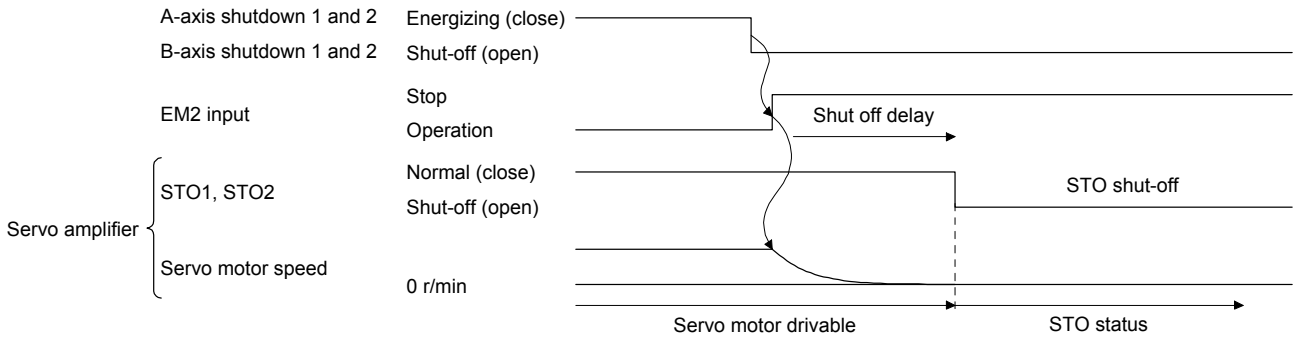

13. USING STO FUNCTION

13.3.3 External I/O signal connection example using an external safety relay unit

POINT

● This connection is for source interface. For the other I/O signals, refer to the connection examples in section 3.2.2.

This connection example complies with the requirement of ISO/EN ISO 13849-1 Category 3 PL d. For details, refer to the safety relay module user's manual.

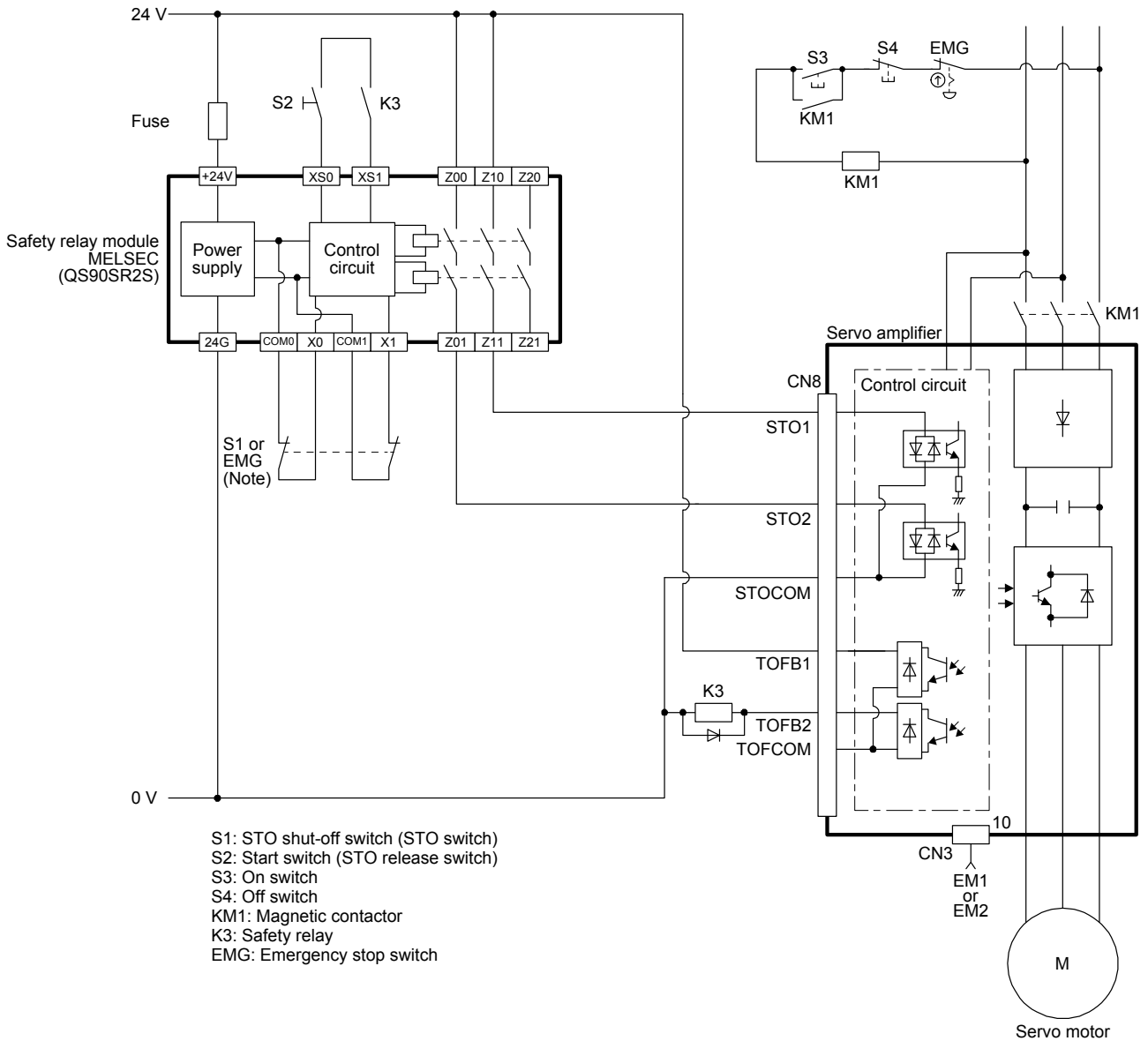

Note. To enable the STO function of the servo amplifier by using "Emergency switching off", change S1 to EMG. The stop category at this time is "0". If STO is turned off while the servo motor is rotating, [AL. 63 STO timing error] will occur.

13. USING STO FUNCTION

13.3.4 External I/O signal connection example using a motion controller

| POINT |
|-------------------------------------------------------------------------------------------------------------------------------------------------------------------------------------------------------------------------------------------------------------------------------------------------|
| <ul style="list-style-type: none"> ● This connection is for source interface. For the other I/O signals, refer to the connection examples in section 3.2.2. ● For MC-Y0B and PC-Y0B, design a sequence program to output MC-Y0B and PC-Y0B after the servo motor stops. |

This connection diagram is an example of STO circuit configured with a servo amplifier and motion controller. Use the switch that complies with the requirement of ISO/EN ISO 13849-1 Category 3 PL d as an emergency stop switch. This connection example complies with the requirement of ISO/EN ISO 13849-1 Category 3 PL d. The following shows an example of I/O (X and Y) signal assignment of the motion controller safety signal module. For details, refer to the motion controller user's manual.

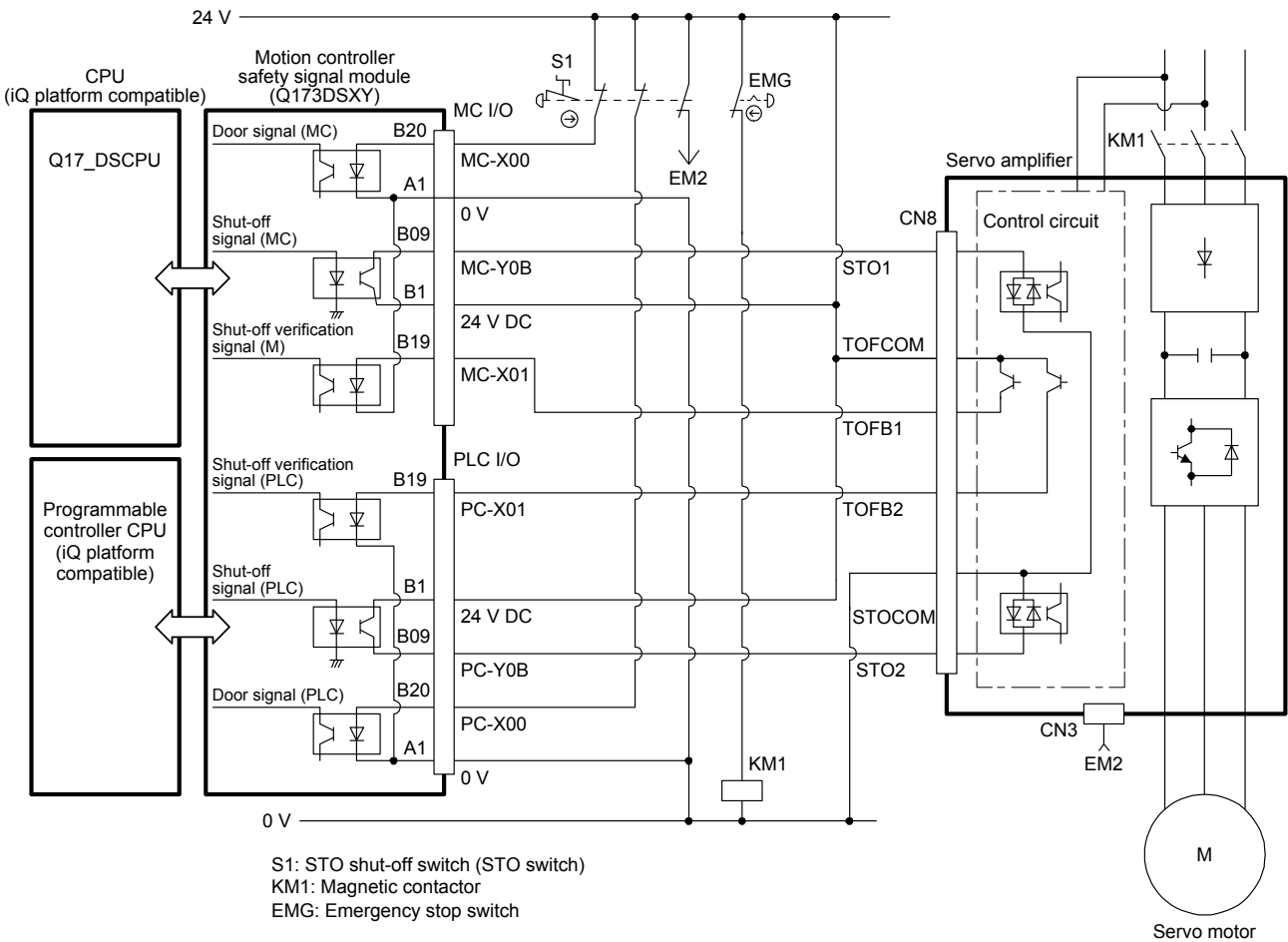

13. USING STO FUNCTION

13.4 Detailed description of interfaces

This section provides the details of the I/O signal interfaces (refer to the I/O division in the table) given in section 13.2. Refer to this section and make connection with the external device.

13.4.1 Sink I/O interface

(1) Digital input interface DI-1

This is an input circuit whose photocoupler cathode side is the input terminal. Transmit signals from sink (open-collector) type transistor output, relay switch, etc.

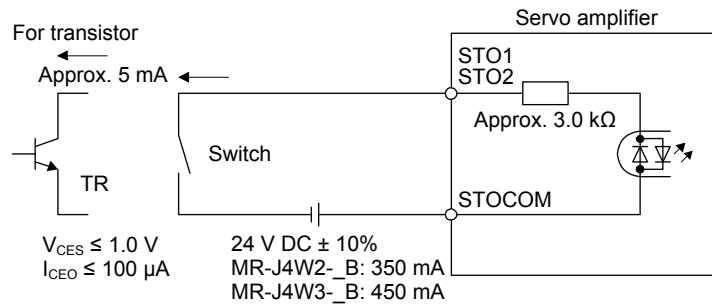

(2) Digital output interface DO-1

This is a circuit in which the collector of the output transistor is the output terminal. When the output transistor is turned on, the current will flow to the collector terminal.

A lamp, relay or photocoupler can be driven. Install a diode (D) for an inductive load, or install an inrush current suppressing resistor (R) for a lamp load.

(Rated current: 40 mA or less, maximum current: 50 mA or less, inrush current: 100 mA or less) A maximum of 5.2 V voltage drop occurs in the servo amplifier.

(a) When outputting two STO states by using each TOFB

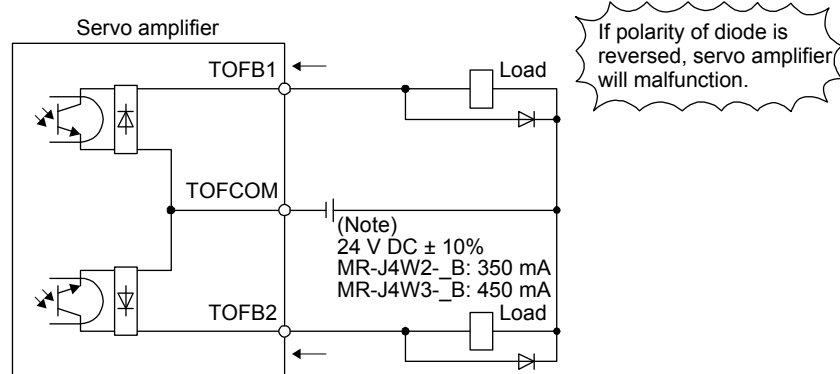

Note. If the voltage drop (maximum of 2.6 V) interferes with the relay operation, apply high voltage (maximum of 26.4 V) from external source.

13. USING STO FUNCTION

(b) When outputting two STO states by using one TOFB

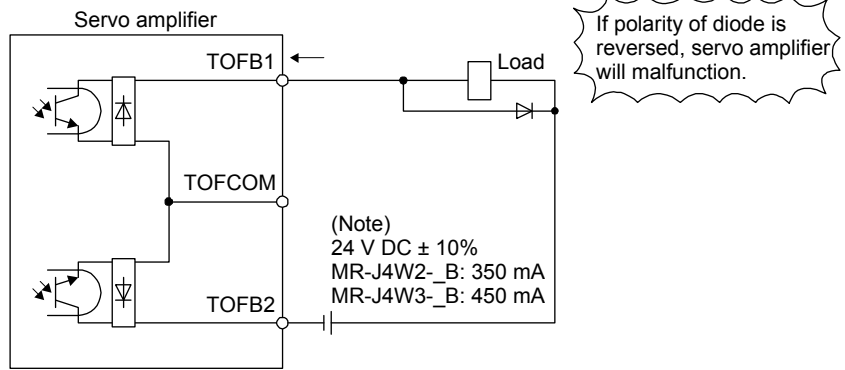

Note. If the voltage drop (maximum of 5.2 V) interferes with the relay operation, apply high voltage (maximum of 26.4 V) from external source.

13.4.2 Source I/O interface

In this servo amplifier, source type I/O interfaces can be used.

(1) Digital input interface DI-1

This is an input circuit whose photocoupler anode side is the input terminal. Transmit signals from source (open-collector) type transistor output, relay switch, etc.

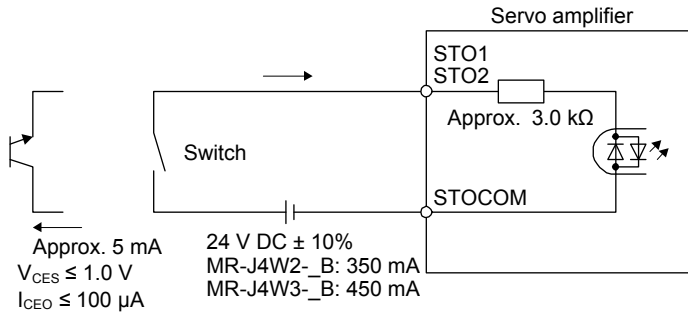

13. USING STO FUNCTION

(2) Digital output interface DO-1

This is a circuit in which the emitter of the output transistor is the output terminal. When the output transistor is turned on, the current will flow from the output terminal to a load. A maximum of 5.2 V voltage drop occurs in the servo amplifier.

(a) When outputting two STO states by using each TOFB

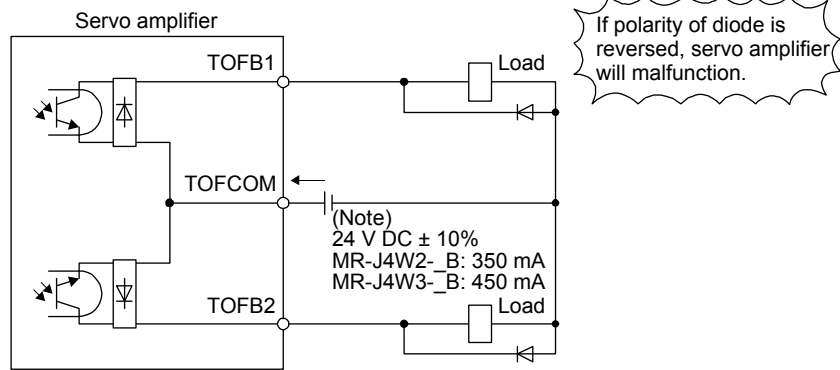

Note. If the voltage drop (maximum of 2.6 V) interferes with the relay operation, apply high voltage (maximum of 26.4 V) from external source.

(b) When outputting two STO states by using one TOFB

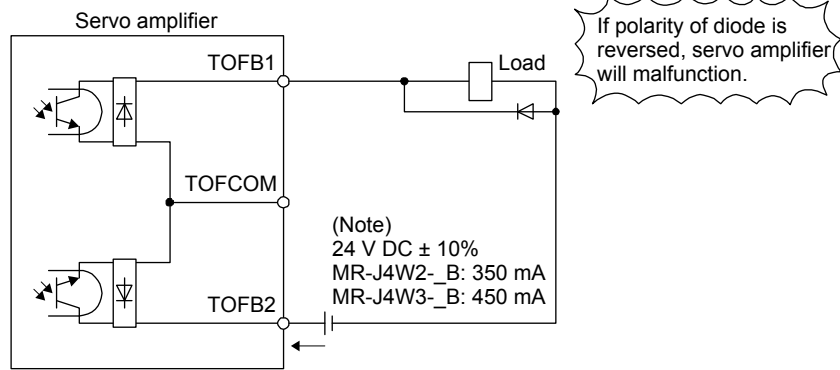

Note. If the voltage drop (maximum of 5.2 V) interferes with the relay operation, apply high voltage (maximum of 26.4 V) from external source.

14. USING A LINEAR SERVO MOTOR

14. USING A LINEAR SERVO MOTOR

WARNING

- When using the linear servo motor, read the "Linear Servo Motor Instruction Manual" and the "Linear Encoder Instruction Manual".
- The MR-J4W2-0303B6 servo amplifier is not compatible with linear servo motor.

14.1 Functions and configuration

14.1.1 Summary

The fields of semiconductor/LCD manufacturing systems, mounters, and others have strong demands for high accuracy, high speed, and efficiency. Therefore, the number of systems using a linear servo motor for a drive axis has been increasing. Since the linear servo system can obtain the characteristics of the high speed and the high acceleration/deceleration greater than the ball screw drive system. The linear servo system also does not have a ball screw wear which is a weak point in the ball screw drive system. This will extend the life of the equipment. In addition, since a response error due to backlash and friction does not occur, you can establish a high-accuracy system.

The following shows the differences between the linear servo motor and the rotary servo motor.

| Category | Item | Differences | | Remark | |
|--------------------------------------------------------------------|----------------------------------------------------------------------------------------------|----------------------------------------|---------------------------------|---------------------------------------------------------------------------------------------------------------------------------------------------------------------------------------------------------------------------------------------------------------------------------------------------------------------------|--|
| | | Linear servo motor | Rotary servo motor | | |
| External I/O signal | FLS (Upper stroke limit), RLS (Lower stroke limit) | Required (for magnetic pole detection) | Not required | Automatically turns on in the parameter setting. | |
| Motor pole adjustment | Magnetic pole detection | Required | Not required (default setting) | Automatically executed at the first servo-on after the power is turned on. For the absolute position linear encoder, [Pr. PL01] can disable the magnetic pole detection. The timing of the magnetic pole detection can be changed with [Pr. PL01]. (Refer to (3) (a) of section 14.3.2.) | |
| Home position return | Reference home position | 1048576 pulses unit (initial value) | One servo motor revolution unit | Home position return pitch can be changed with parameter setting. (Refer to section 14.3.3) | |
| Absolute position detection system | Absolute position encoder battery (1 battery case (MR-BT6VCASE) and 5 batteries (MR-BAT6V1)) | Not required | Required | The following alarms and warnings are not provided for the linear servo motor. <ul style="list-style-type: none"> • [AL. 25 Absolute position erased] • [AL. 92 Battery cable disconnection warning] • [AL. 9F Battery warning] • [AL. E3 Absolute position counter warning] | |
| Auto tuning | Load to motor inertia ratio (J) | Load to motor mass ratio | Load to motor inertia ratio | | |
| MR Configurator2 (SW1DNC-MRC2-_) (Software version 1.19V or later) | Motor speed (Data display and setting) | mm/s unit | r/min unit | | |
| | Test operation function | Positioning operation | Supported | Supported | |
| | | Motor-less operation | None | Supported | |
| | | JOG operation | None | Supported | |
| | | Program operation | Supported | Supported | |

14. USING A LINEAR SERVO MOTOR

14.1.2 Servo system with auxiliary equipment

CAUTION ● Connecting a linear servo motor for different axis to the CNP3A, CNP3B, or CNP3C connector may cause a malfunction.

POINT

- Equipment other than the servo amplifier and linear servo motor are optional or recommended products.
- When using the linear servo motor, set [Pr. PA01] to "_ _ 4 _".

The configuration diagram is an example of MR-J4W3-222B. When using the other servo amplifiers, the configuration will be the same as rotary servo motors except for connections of linear servo motors and linear encoders. Refer to section 1.7 depending on servo amplifiers you use.

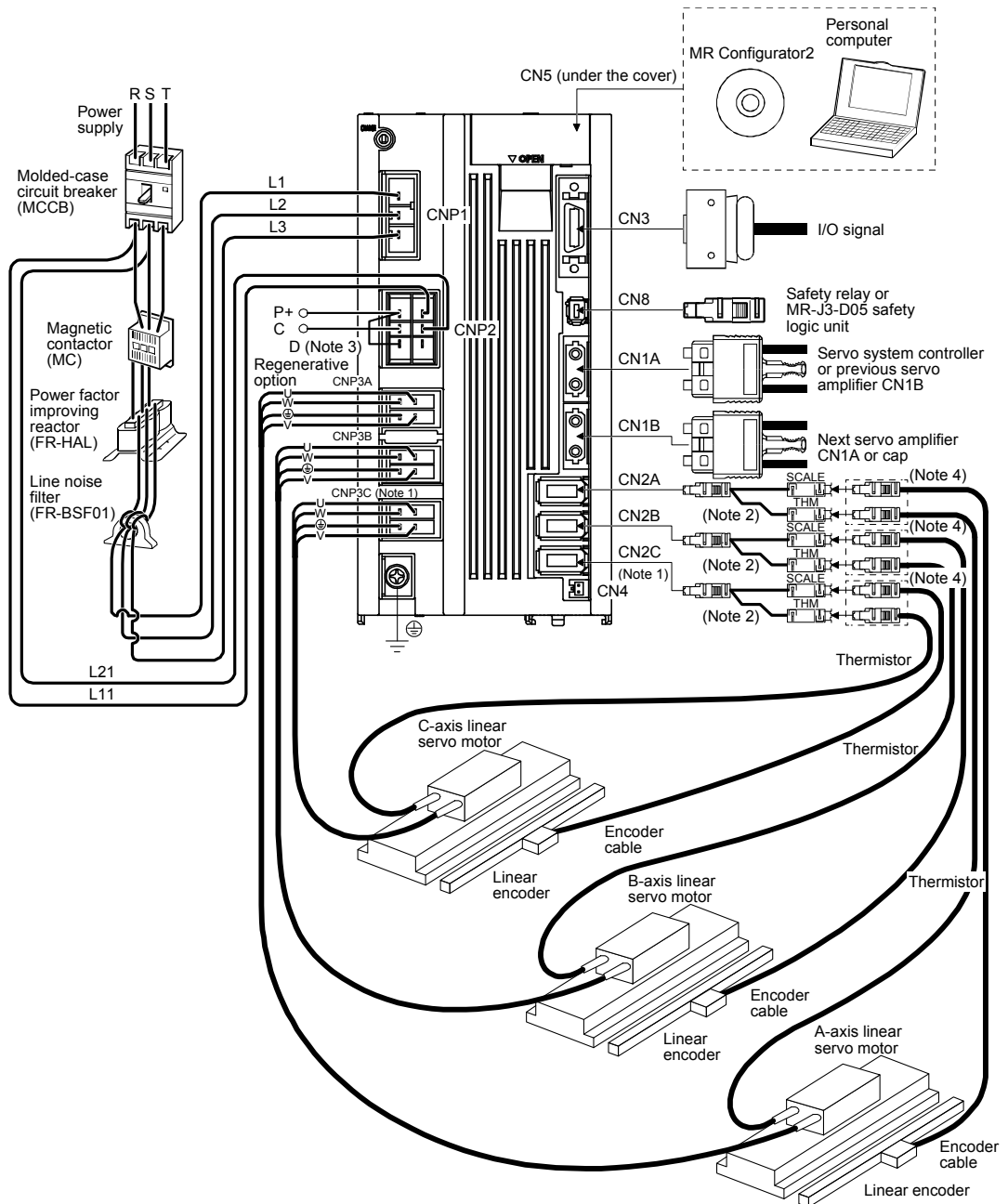

14. USING A LINEAR SERVO MOTOR

- Note
1. This figure shows the 3-axis servo amplifier.
 2. For the branch cable, use the MR-J4THCBL03M (optional).
 3. Always connect between P+ and D terminals. When using the regenerative option, refer to section 11.2.
 4. Connect the thermistor to THM of branch cable and connect the encoder cable to SCALE correctly. Incorrect setting will trigger [AL. 16].

14.2 Signals and wiring



WARNING

- Any person who is involved in wiring should be fully competent to do the work.
- Before wiring, turn off the power and wait for 15 minutes or more until the charge lamp turns off. Then, confirm that the voltage between P+ and N- is safe with a voltage tester and others. Otherwise, an electric shock may occur. In addition, when confirming whether the charge lamp is off or not, always confirm it from the front of the servo amplifier.
- Ground the servo amplifier and the linear servo motor securely.
- Do not attempt to wire the servo amplifier and the linear servo motor until they have been installed. Otherwise, it may cause an electric shock.
- The cables should not be damaged, stressed, loaded, or pinched. Otherwise, it may cause an electric shock.
- To avoid an electric shock, insulate the connections of the power supply terminals.



CAUTION

- Wire the equipment correctly and securely. Otherwise, the linear servo motor may operate unexpectedly, resulting in injury.
- Connect cables to the correct terminals. Otherwise, a burst, damage, etc. may occur.
- Ensure that polarity (+/-) is correct. Otherwise, a burst, damage, etc. may occur.
- The surge absorbing diode installed to the DC relay for control output should be fitted in the specified direction. Otherwise, the emergency stop and other protective circuits may not operate.

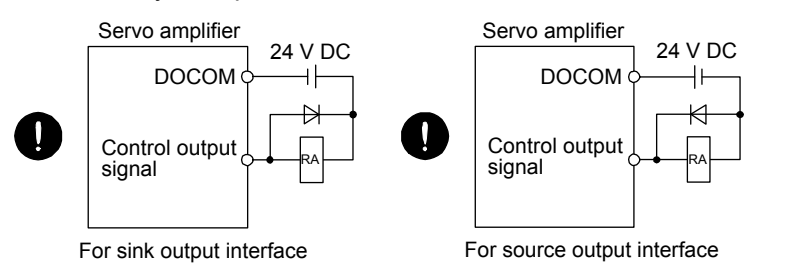

For sink output interface

For source output interface

- Use a noise filter, etc. to minimize the influence of electromagnetic interference. Electromagnetic interference may be given to the electronic equipment used near the servo amplifier.
- Do not install a power capacitor, surge killer or radio noise filter (FR-BIF option) with the power wire of the linear servo motor.
- When using the regenerative resistor, switch power off with the alarm signal. Otherwise, a transistor fault or the like may overheat the regenerative resistor, causing a fire.

14. USING A LINEAR SERVO MOTOR

- Connect the servo amplifier power output (U/V/W) to the linear servo motor power input (U/V/W) directly. Do not let a magnetic contactor, etc. intervene. Otherwise, it may cause a malfunction.

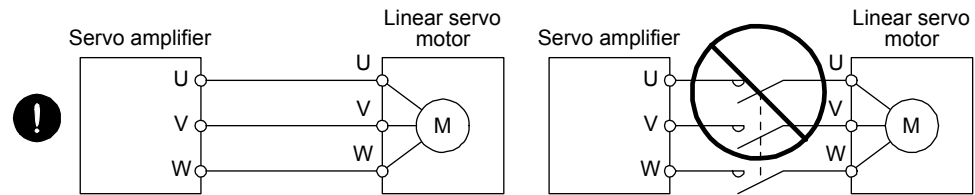

⚠ CAUTION

- Before wiring, switch operation, etc., eliminate static electricity. Otherwise, it may cause a malfunction.
- Do not modify the equipment.
- The cables such as power wires deriving from the primary side cannot stand the long-term bending action. Avoid the bending action by fixing the cables to the moving part, etc. Also, use the cable that stands the long-term bending action for the wiring to the servo amplifier.
- Connecting a linear servo motor for different axis to the CNP3A, CNP3B, or CNP3C connector may cause a malfunction.

This chapter does not describe the following items. For details of the items, refer to each section of the detailed description field.

| Item | Detailed explanations |
|---------------------------------------------------|-----------------------|
| Input power supply circuit | Section 3.1 |
| Explanation of power supply system | Section 3.3 |
| Signal (device) explanations | Section 3.5 |
| Alarm occurrence timing chart | Section 3.7 |
| Interfaces | Section 3.8 |
| SSCNET III cable connection | Section 3.9 |
| Grounding | Section 3.11 |
| Switch setting and display of the servo amplifier | Section 4.3 |

14. USING A LINEAR SERVO MOTOR

14.3 Operation and functions

14.3.1 Startup

| | |
|--------------|--------------------------------------------------------------------------|
| POINT | <p>● When using the linear servo motor, set [Pr. PA01] to "_ _ 4 _".</p> |
|--------------|--------------------------------------------------------------------------|

(1) Startup procedure

Start up the linear servo system in the following procedure.

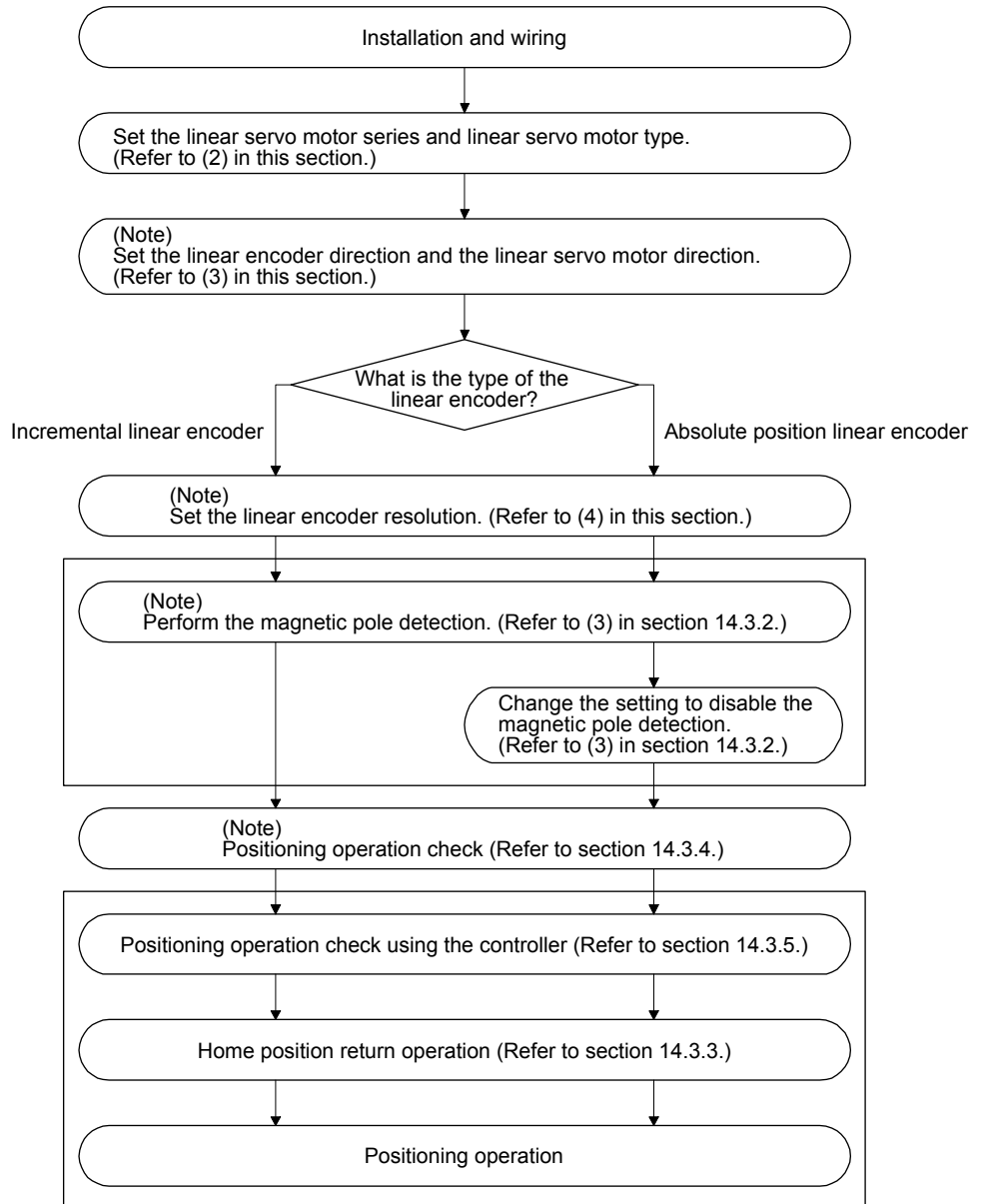

Note. Use MR Configurator2.

(2) Set the linear servo motor series and linear servo motor type.

To use the linear servo motor, set the linear servo motor series and linear servo motor type with [Pr. PA17 Servo motor series setting] and [Pr. PA18 Servo motor type setting]. (Refer to section 5.2.1.)

14. USING A LINEAR SERVO MOTOR

(3) Settings of the linear encoder direction and the linear servo motor direction

Set the first digit of [Pr. PC27] (Encoder pulse count polarity selection) so that the positive direction of the linear servo motor matches with the increasing direction of the linear encoder feedback.

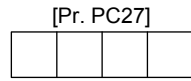

Encoder pulse count polarity selection
 0: Linear servo motor positive direction and linear encoder increasing direction
 1: Linear servo motor positive direction and linear encoder decreasing direction

(a) Parameter setting method

- 1) Confirm the positive direction of the linear servo motor. [Pr. PA14] determines the relation of the travel direction of the linear servo motor under commands as shown below.

| [Pr. PA14] setting | Travel direction of linear servo motor | |
|--------------------|----------------------------------------|----------------------------|
| | Address increasing command | Address decreasing command |
| 0 | Positive direction | Negative direction |
| 1 | Negative direction | Positive direction |

The positive/negative directions of the linear servo motor are as follows.

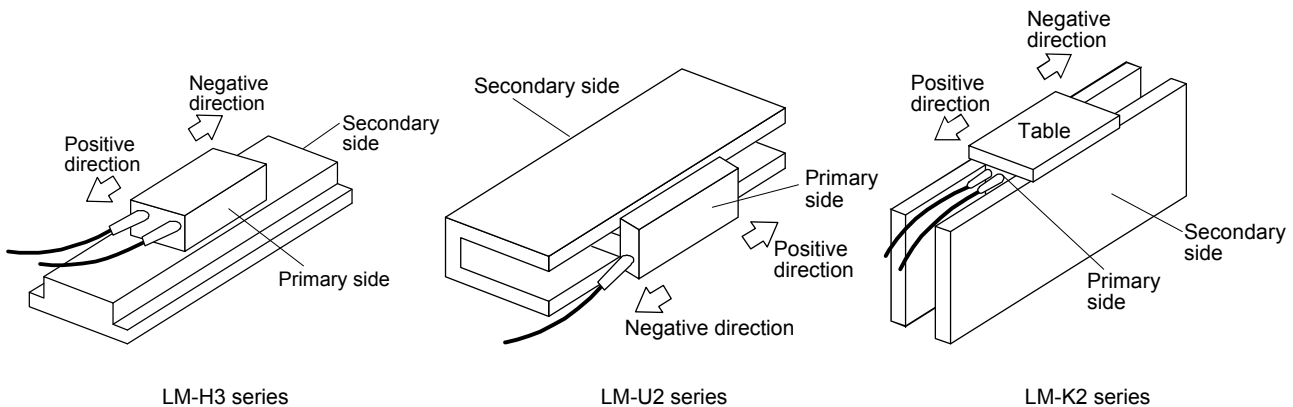

- 2) Confirm the increasing direction of the linear encoder.

- 3) If the positive direction of the linear servo motor matches with the increasing direction of the linear encoder, set [Pr. PC27] to "___0". If the positive direction of the linear servo motor does not match with the increasing direction of the linear encoder, set [Pr. PC27] to "___1".

(b) Confirmation method

Confirm the positive direction of the linear servo motor and the increasing direction of the linear encoder in the following procedure.

- 1) In servo-off status, move the linear servo motor in the positive direction manually.
- 2) Confirm the motor speed (in the positive and negative directions) at that time with MR Configurator2.

14. USING A LINEAR SERVO MOTOR

- 3) When [Pr. PC27] is set to "___ 0" and the positive direction of the linear servo motor matches with the increasing direction of the linear encoder, if the linear servo motor operates in the positive direction, the motor speed will be a positive value. If the positive direction of the linear servo motor does not match with the increasing direction of the linear encoder, the motor speed will be a negative value. When [Pr. PC27] is set to "___ 1" and the positive direction of the linear servo motor matches with the increasing direction of the linear encoder, if the linear servo motor operates in the positive direction, the motor speed will be a negative value.

(4) Linear encoder resolution setting

| POINT |
|-----------------------------------------------------------------------------------------------------------------------------------------------------------------------------------------------------------------------------------------------------------------------------------------------------------------------------------------|
| <ul style="list-style-type: none"> ● To enable the parameter value, cycle the power after setting. ● If an incorrect value is set for [Pr. PL02] or [Pr. PL03], the linear servo motor may not operate properly, or [AL. 27] or [AL. 42] may occur at the positioning operation or the magnetic pole detection. |

Set the ratio of the electronic gear to the linear encoder resolution with [Pr. PL02 Linear encoder resolution - Numerator] and [Pr. PL03 Linear encoder resolution - Denominator].

(a) Parameter setting

Set the values that apply to the following equation.

$$\frac{[\text{Pr. PL02 Linear encoder resolution - Numerator}]}{[\text{Pr. PL03 Linear encoder resolution - Denominator}]} = \text{Linear encoder resolution } [\mu\text{m}]$$

(b) Parameter setting example

When the linear encoder resolution is 0.5 μm

$$\frac{[\text{Pr. PL02}]}{[\text{Pr. PL03}]} = \text{Linear encoder resolution} = 0.5 \mu\text{m} = \frac{1}{2}$$

The following shows the simplified chart for the setting values of [Pr. PL02] and [Pr. PL03].

| | | Linear encoder resolution [μm] | | | | | | | |
|---------------|------------|---------------------------------------------|------|------|-----|-----|-----|-----|-----|
| | | 0.01 | 0.02 | 0.05 | 0.1 | 0.2 | 0.5 | 1.0 | 2.0 |
| Setting value | [Pr. PL02] | 1 | 1 | 1 | 1 | 1 | 1 | 1 | 2 |
| | [Pr. PL03] | 100 | 50 | 20 | 10 | 5 | 2 | 1 | 1 |

14. USING A LINEAR SERVO MOTOR

14.3.2 Magnetic pole detection

| POINT |
|-------------------------------------------------------------------------------------------------------------------------------------------------------|
| <ul style="list-style-type: none"> ● Set [Pr. PE47 Torque offset] to "0 (initial value)" before executing the magnetic pole detection. |

Before the positioning operation of the linear servo motor, make sure to perform the magnetic pole detection. When [Pr. PL01] is set to the initial value, perform the magnetic pole detection only at the first servo-on after the power is turned on.

The magnetic pole detection includes the following two methods. Each method has advantages and disadvantages. Select a magnetic pole detection method suitable for your usage.

The position detection method is selected in the initial setting.

| Magnetic pole detection | Advantage | Disadvantage |
|----------------------------------|-----------------------------------------------------------------------------------------------------------------------------------------------------------------------------------------------------------------|------------------------------------------------------------------------------------------------------------------------------------------------------------------------------------------------------------------------------------------------------------|
| Position detection method | <ol style="list-style-type: none"> 1. The magnetic pole detection has a high degree of accuracy. 2. The adjustment procedure at the magnetic pole detection is simple. | <ol style="list-style-type: none"> 1. The travel distance at the magnetic pole detection is large. 2. For equipment with small friction, the initial magnetic pole detection error may occur. |
| Minute position detection method | <ol style="list-style-type: none"> 1. The travel distance at the magnetic pole detection is small. 2. Even for equipment with small friction, the magnetic pole detection is available. | <ol style="list-style-type: none"> 1. The adjustment procedure at the magnetic pole detection is complex. 2. If a disturbance occurs during the magnetic pole detection, [AL. 27 Initial magnetic pole detection error] may occur. |

14. USING A LINEAR SERVO MOTOR

(1) Magnetic pole detection method by using MR Configurator2

The following shows the magnetic pole detection procedure by using MR Configurator2.

(a) Magnetic pole detection by the position detection method

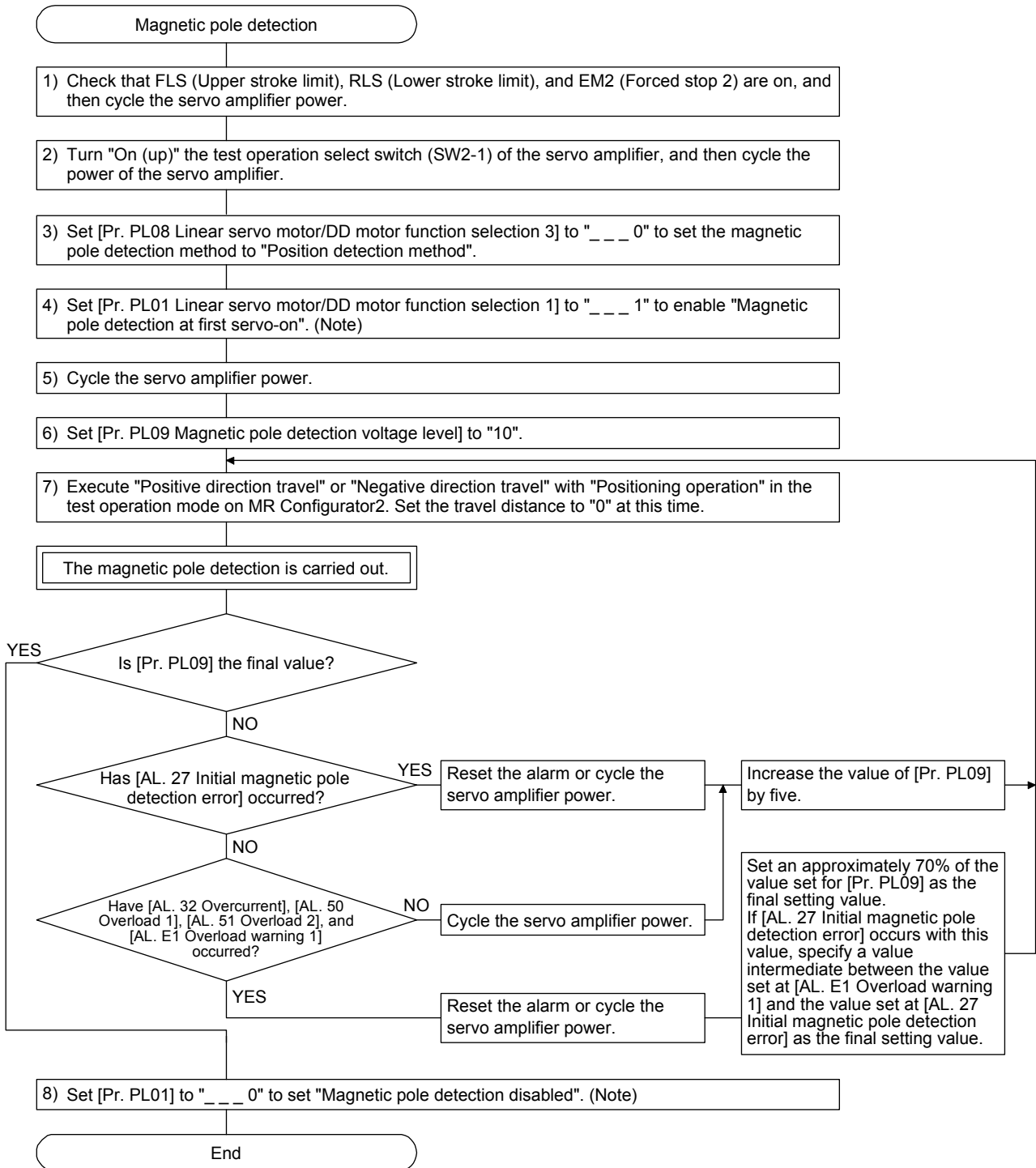

Note. For the incremental system, the [Pr. PL01] setting is not required.

14. USING A LINEAR SERVO MOTOR

(b) Magnetic pole detection by the minute position detection method

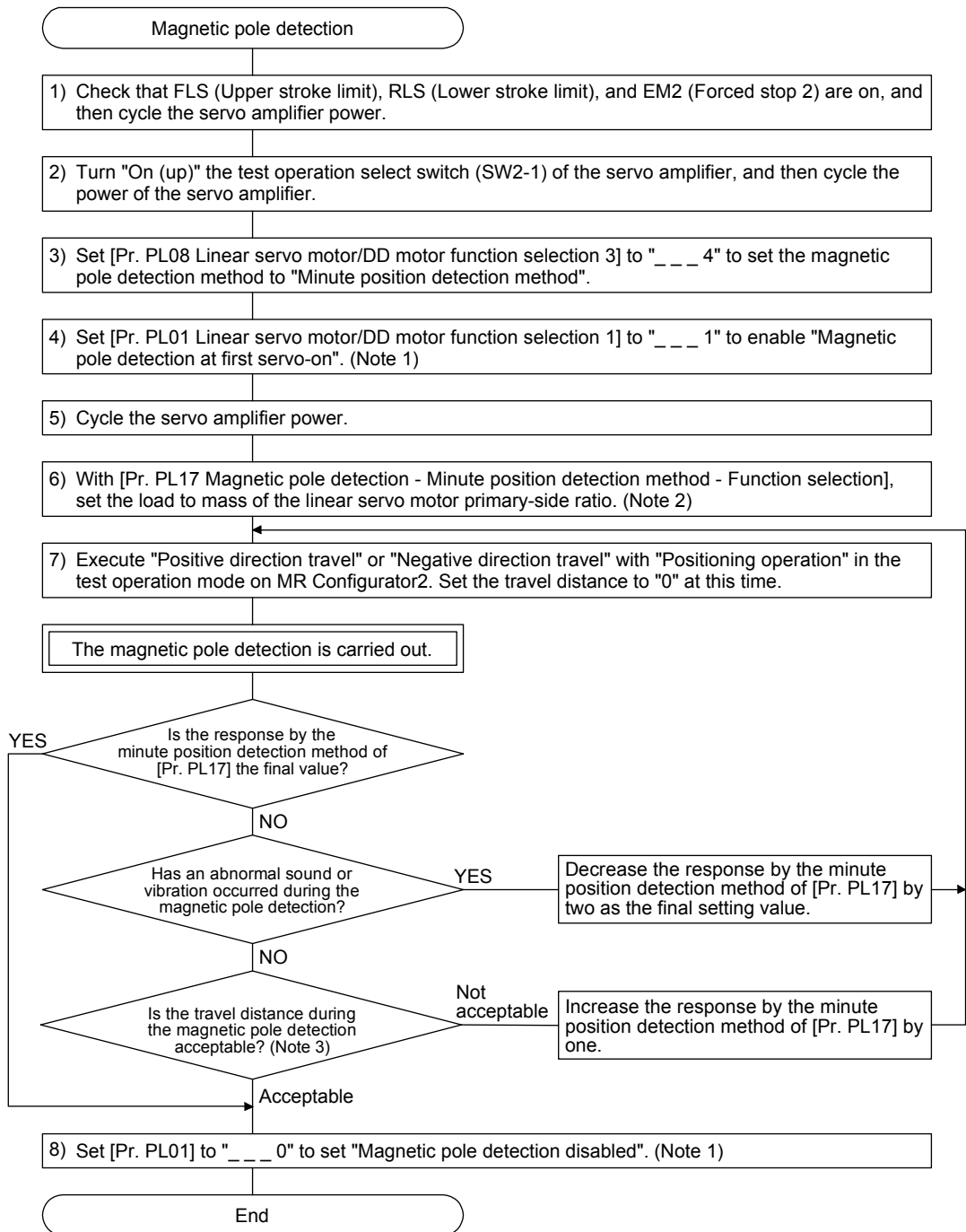

- Note 1. When the linear encoder is an incremental type, the [Pr. PL01] setting is not required.
- Note 2. If the load to primary-side linear servo motor mass ratio is unknown, perform the magnetic pole detection by the position detection method, and then perform the auto tuning to set an estimated value.
- Note 3. For the magnetic pole detection by the minute position detection method, the maximum travel distance at the magnetic pole detection must be 0.5 mm or less. To shorten the travel distance, increase the response by the minute position detection method in [Pr. PL17].

14. USING A LINEAR SERVO MOTOR

- (c) State transition of the servo amplifier display (3-digit, 7-segment LED) at the magnetic pole detection
 When the magnetic pole detection with MR Configurator2 is normally executed, the servo amplifier display (3-digit, 7-segment LED) shows the state as below.

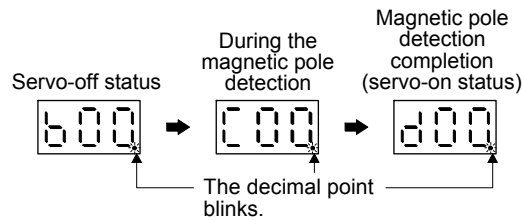

- (2) Preparation for the magnetic pole detection

| POINT |
|------------------------------------------------------------------------------------------------------------------------------------------------------------------------------------------------------------------------------------------------------------------------------|
| <ul style="list-style-type: none"> ● When the test operation mode is selected with the test operation select switch (SW2-1), the SSCNET III/H communication for the servo amplifier in the test operation mode and the following servo amplifiers is blocked. |

For the magnetic pole detection, use the test operation mode (positioning operation) of MR Configurator2. Turn off the servo amplifier power, and set the test operation select switch (SW2-1) as shown below. Turning on the power enables the test operation mode.

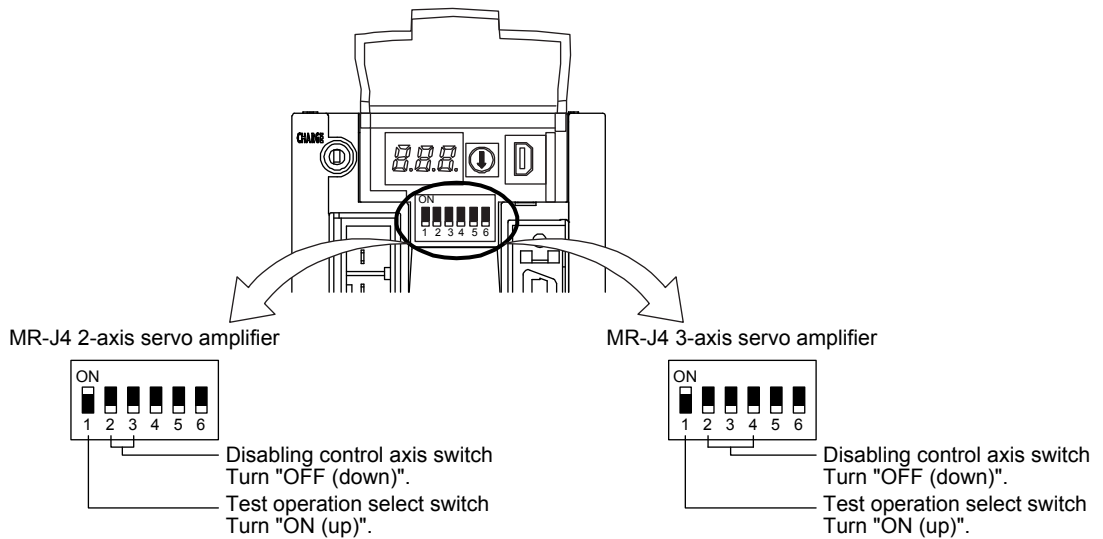

14. USING A LINEAR SERVO MOTOR

(3) Operation at the magnetic pole detection



WARNING

- Note that the magnetic pole detection automatically starts simultaneously with the turning-on of the servo-on command.



CAUTION

- If the magnetic pole detection is not executed properly, the linear servo motor may operate unexpectedly.

POINT

- Establish the machine configuration using FLS (Upper stroke limit) and RLS (Lower stroke limit). Otherwise, the machine may be damaged due to a collision.
- At the magnetic pole detection, whether the linear servo motor moves in the positive or negative direction is unpredictable.
- Depending on the setting value of [Pr. PL09 Magnetic pole detection voltage level], an overload, overcurrent, magnetic pole detection alarm, or others may occur.
- When performing the positioning operation from a controller, use the sequence which confirms the normal completion of the magnetic pole detection and the servo-on status, then outputs the positioning command. If the controller outputs the positioning command before RD (Ready) turns on, the command may not be accepted or a servo alarm may occur.
- After the magnetic pole detection, check the positioning accuracy with the test operation (positioning operation function) of MR Configurator2.
- When the absolute position linear encoder is used, if a gap is generated to the positional relation between the linear encoder and the linear servo motor, perform the magnetic pole detection again.
- The accuracy of the magnetic pole detection improves with no load.
- An alarm may occur when the linear encoder is not mounted properly, or when the linear encoder resolution setting ([Pr. PL02] and [Pr. PL03]) or the setting value of [Pr. PL09 Magnetic pole detection voltage level] is incorrect.
- For the machine that its friction becomes 30% or more of the continuous thrust, the linear servo motor may not operate properly after the magnetic pole detection.
- For the horizontal shaft of the machine that its unbalanced thrust becomes 20% or more of the continuous thrust, the linear servo motor may not operate properly after the magnetic pole detection.
- For the machine that multiple axes are connected like a tandem configuration, if you try to perform the magnetic pole detection simultaneously for multiple axes, the magnetic pole detection may not be executed. Perform the magnetic pole detection for each axis. At this time, set the axes that the magnetic pole detection is not performed for to servo-off.

14. USING A LINEAR SERVO MOTOR

(a) For the incremental linear encoder

| | |
|--------------|-------------------------------------------------------------------------------------------------------------------------|
| POINT | <p>● For the incremental linear encoder, the magnetic pole detection is required every time the power is turned on.</p> |
|--------------|-------------------------------------------------------------------------------------------------------------------------|

By turning on the servo-on command from the controller after the power-on, the magnetic pole detection is automatically carried out. Therefore, there is no need to set the parameter (first digit of [Pr. PL01]) for executing the magnetic pole detection.

1) Timing chart

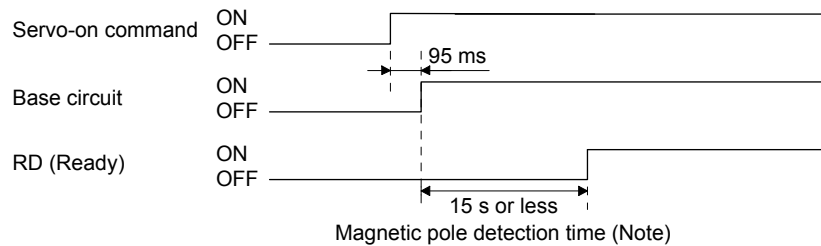

Note. The magnetic pole detection time indicates the operation time when FLS (Upper stroke limit) and RLS (Lower stroke limit) are on.

2) Linear servo motor movement (when FLS (Upper stroke limit) and RLS (Lower stroke limit) are on)

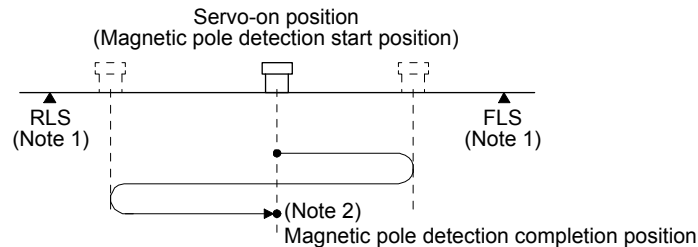

Note 1. When you turn off FLS (Upper stroke limit) or RLS (Lower stroke limit) during the magnetic pole detection, the operation of the magnetic pole detection is carried on to the opposite direction. When both FLS and RLS are off, [AL. 27 Initial magnetic pole detection error] occurs.

2. The following shows the pitch against the magnetic pole.

| Linear servo motor series | LM-H3 | LM-U2 | | LM-K2 |
|----------------------------------|-------|----------------------------------------------------------|-------------------------------------------------------|-------|
| | | Medium thrust (Continuous thrust: Less than 400 N) | Large thrust (Continuous thrust: 400 N or more) | |
| Pitch against magnetic pole [mm] | 48 | 30 | 60 | 48 |

14. USING A LINEAR SERVO MOTOR

- 3) Linear servo motor movement (when FLS (Upper stroke limit) or RLS (Lower stroke limit) is off)
When FLS or RLS is off at servo-on, the magnetic pole detection is carried out as follows.

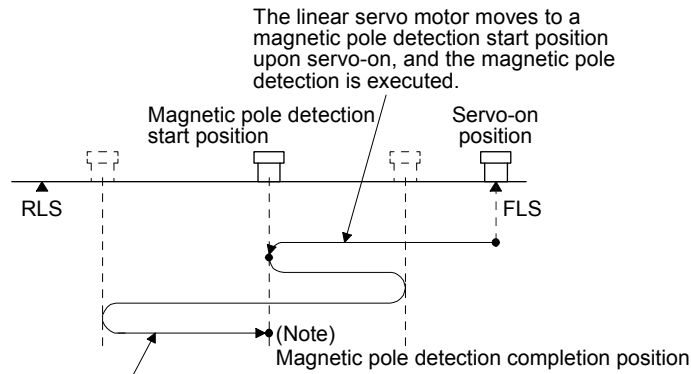

The linear servo motor reciprocates several times and returns to the magnetic pole detection start position to complete the magnetic pole detection and to go into the servo-lock status. At this time, there may be a gap, approximately a quarter of the pitch against magnetic pole, from the start position.

Note. For the pitch against magnetic pole, refer to (3) (a) 2) Note 2 in this section.

- (b) For the absolute position linear encoder

| POINT |
|---------------------------------------------------------------------------------------------------------------------------------------------------------------------------------------------------------------------------------------------------------------------------------------------------------------------------------------------------------------------------------------------------------------------------------------------------------------------------------------------------------------------------------------------------------------------------------------------------------------------|
| <ul style="list-style-type: none"> ● The magnetic pole detection is required in the following timings. <ul style="list-style-type: none"> ▪ When the system is set up (at the first startup of equipment) ▪ After a servo amplifier is replaced ▪ After a linear servo motor (primary-side or secondary-side) is replaced ▪ After a linear encoder (scale or head) is replaced or remounted ● If a gap is generated to the positional relation between the linear encoder and the linear servo motor, perform the magnetic pole detection again. |

Perform the magnetic pole detection in the following procedure.

- 1) Set [Pr. PL01 Linear servo motor/DD motor function selection 1] to "___ 1" (Magnetic pole detection at first servo-on).

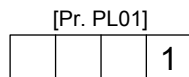

Magnetic pole detection at first servo-on (Initial value)

- 2) Execute the magnetic pole detection. (Refer to (3) (a) 1), 2) in this section.)

14. USING A LINEAR SERVO MOTOR

- 3) After the completion of the magnetic pole detection, change [Pr. PL01] to " __ _ 0" (Magnetic pole detection disabled).

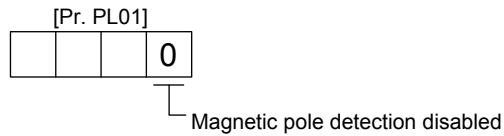

After the magnetic pole detection, by disabling the magnetic pole detection function with [Pr. PL01], the magnetic pole detection after each power-on is not required.

- (4) Magnetic pole detection method setting

| POINT |
|----------------------------------------------------------------------------------------------------------------------------------------------------------------------------------------------------------------------------------------------------------------------------------------------------------------------------------------------|
| <p>● In the following cases, set the magnetic pole detection method to the minute position detection method.</p> <ul style="list-style-type: none"> ▪ When a shorten travel distance at the magnetic pole detection is required ▪ When the magnetic pole detection by the position detection method is not completed |

Set the magnetic pole detection method using the first digit of [Pr. PL08] (Magnetic pole detection method selection).

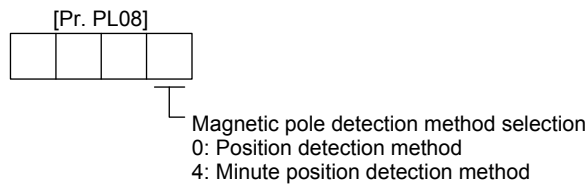

- (5) Setting of the magnetic pole detection voltage level by the position detection method

For the magnetic pole detection by the position detection method, set the voltage level with [Pr. PL09 Magnetic pole detection voltage level]. For the magnetic pole detection by the minute position detection method, the voltage level setting is not required.

- (a) Guideline of parameter settings

Set the parameters by referring to the following table.

| | [Pr. PL09] setting (guide value) | |
|----------------------------------|-------------------------------------------------------------------|-------------------|
| Servo status | Small ← Medium → Large (10 or less (initial value) 50 or more) | |
| Thrust at operation | Small | Large |
| Overload, overcurrent alarm | Seldom occurs | Frequently occurs |
| Magnetic pole detection alarm | Frequently occurs | Seldom occurs |
| Magnetic pole detection accuracy | Low | High |

- (b) Setting procedure

- 1) Perform the magnetic pole detection, and increase the setting value of [Pr. PL09 Magnetic pole detection voltage level] until [AL. 50 Overload 1], [AL. 51 Overload 2], [AL. 33 Overvoltage], [AL. E1 Overload warning 1], and [AL. EC Overload warning 2] occur. Increase the setting value by five as a guide value. When these alarms and warnings occur during the magnetic pole detection by using MR Configurator2, the test operation of MR Configurator2 automatically completes and the servo-off status is established.

14. USING A LINEAR SERVO MOTOR

- 2) Specify the setting value that is an approximately 70% of the value set when [AL. 50 Overload 1], [AL. 51 Overload 2], [AL. 33 Overvoltage], [AL. E1 Overload warning 1], and [AL. EC Overload warning 2] occurred as the final setting value. However, if [AL. 27 Initial magnetic pole detection error] occurs with this value, specify a value intermediate between the value set at [AL. 50 Overload 1], [AL. 51 Overload 2], [AL. 33 Overvoltage], [AL. E1 Overload warning 1], and [AL. EC Overload warning 2] and the value set at the magnetic pole detection alarm as the final setting value.
- 3) Perform the magnetic pole detection again with the final setting value to check there is no problem.

(c) Setting example

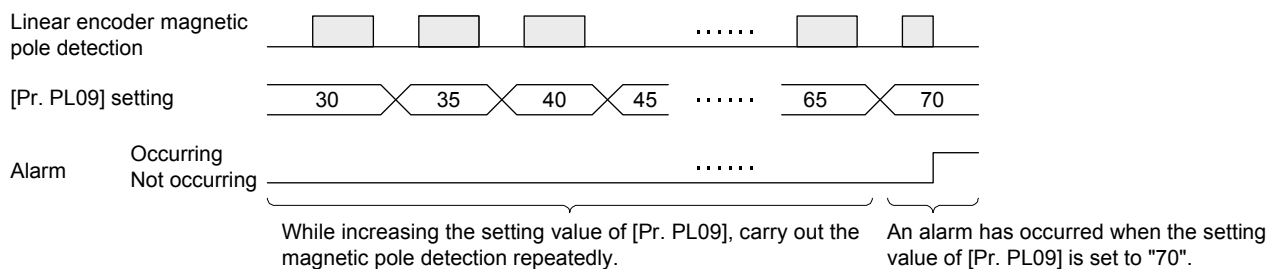

In this example, the final setting value of [Pr. PL09] is 49 (Setting value at the alarm occurrence = 70×0.7).

14.3.3 Home position return

| |
|--------------------------------------------------------------------------------------------------------------------------------------------------------------------------------------------------|
| POINT |
| <ul style="list-style-type: none"> ● The incremental linear encoder and the absolute position linear encoder have different reference home positions at the home position return. |

(1) Incremental linear encoder

| | |
|--|---------------------------------------------------------------------------------------------------------------------------------------------------------------------------------------------------------------------------------------------|
| | <ul style="list-style-type: none"> ● If the resolution or the stop interval (the third digit of [Pr. PL01]) of the linear encoder is large, it is very dangerous since the linear servo motor may crash into the stroke end. |
|--|---------------------------------------------------------------------------------------------------------------------------------------------------------------------------------------------------------------------------------------------|

14. USING A LINEAR SERVO MOTOR

- (a) When the linear encoder home position (reference mark) exists in the home position return direction
 When an incremental linear encoder is used, the home position is the position per 1048576 pulses (changeable with the third digit of [Pr. PL01]) with reference to the linear encoder home position (reference mark) passed through first after a home position return start. Change the setting value of [Pr. PL01] according to the linear encoder resolution.

[Pr. PL01]

Stop interval setting at the home position return

| Setting value | Stop interval [pulse] |
|---------------|-------------------------|
| 0 | 8192 |
| 1 | 131072 |
| 2 | 262144 |
| 3 | 1048576 (initial value) |
| 4 | 4194304 |
| 5 | 16777216 |
| 6 | 67108864 |

The following shows the relation between the stop interval at the home position return and the linear encoder resolution. For example, when the linear encoder resolution is 0.001 μm and the parameter for the stop interval at the home position return, [Pr. PL01], is set to "_ 5 _ _" (16777216 pulses), the stop interval is 16.777 mm. The value inside a bold box indicates the recommended stop interval for each linear encoder resolution.

[Unit: mm]

| Pr. PL01 | Linear encoder resolution [μm] Stop interval [pulse] | 0.001 | 0.005 | 0.01 | 0.02 | 0.05 | 0.1 | 0.2 | 0.5 | 1 | 2 |
|----------|----------------------------------------------------------------------|---------------|---------------|---------------|---------------|---------------|---------------|-----------|-----------|-----------|------------|
| | | _ 0 _ _ | 8192 | 0.008 | 0.041 | 0.082 | 0.164 | 0.410 | 0.819 | 1.638 | 4.096 |
| _ 1 _ _ | 131072 | 0.131 | 0.655 | 1.311 | 2.621 | 6.554 | 13.107 | 26.214 | 65.536 | 131.072 | 262.144 |
| _ 2 _ _ | 262144 | 0.262 | 1.311 | 2.621 | 5.243 | 13.107 | 26.214 | 52.429 | 131.072 | 262.144 | 524.288 |
| _ 3 _ _ | 1048576 | 1.049 | 5.243 | 10.486 | 20.972 | 52.429 | 104.858 | 209.715 | 524.288 | 1048.576 | 2097.152 |
| _ 4 _ _ | 4194304 | 4.194 | 20.972 | 41.943 | 83.886 | 209.715 | 419.430 | 838.861 | 2097.152 | 4194.304 | 8388.608 |
| _ 5 _ _ | 16777216 | 16.777 | 83.886 | 167.772 | 335.544 | 838.861 | 1677.722 | 3355.443 | 8388.608 | 16777.216 | 33554.432 |
| _ 6 _ _ | 67108864 | 67.109 | 335.544 | 671.089 | 1342.177 | 3355.443 | 6710.886 | 13421.773 | 33554.432 | 67108.864 | 134217.728 |

14. USING A LINEAR SERVO MOTOR

In the case of a proximity dog type home position return, the nearest reference home position after proximity dog off is the home position.

Set one linear encoder home position in the full stroke, and set it in the position that can always be passed through after a home position return start. LZ (Encoder Z-phase pulse) cannot be used.

When two or more reference marks exist during the full stroke of the linear encoder, select "Enabled (_ 1 _)" of "Linear scale multipoint Z-phase input function selection" in [Pr. PC17].

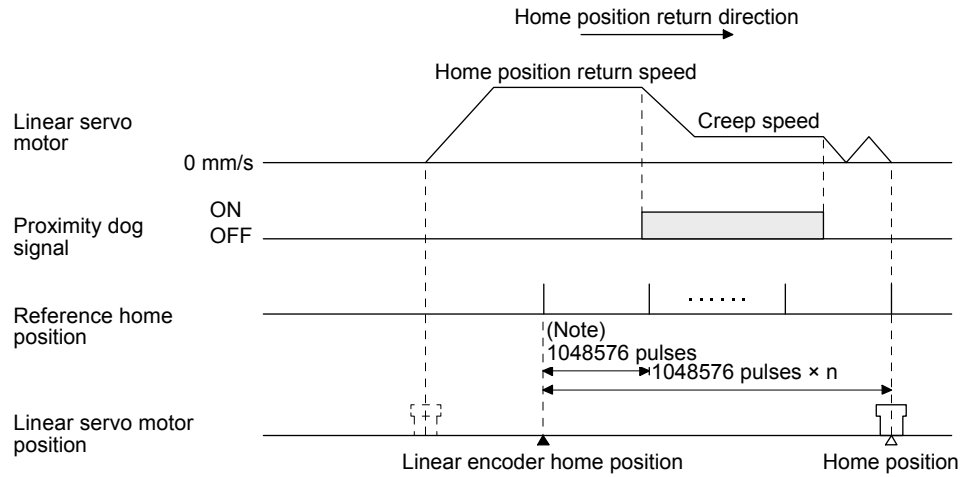

Note. Changeable with [Pr. PL01].

14. USING A LINEAR SERVO MOTOR

(b) When the linear encoder home position does not exist in the home position return direction

| POINT |
|--------------------------------------------------------------------------------------------------------------------------------------------------------------------------------------------------------------------------------------------------------------------------------------------------------------------------------------------------|
| <ul style="list-style-type: none"> ● To execute a home position return securely, start a home position return after moving the linear servo motor to the opposite stroke end with JOG operation from the controller and others. ● Change the third digit value of [Pr. PL01] according to the linear encoder resolution. |

If the home position return is performed from the position where the linear encoder does not exist in the home position return direction, a home position return error occurs on the controller. The error contents differ according to the controller type. Move the linear servo motor to the stroke end on the opposite side of the home position return direction with the JOG operation from the controller and others, and then perform a home position return.

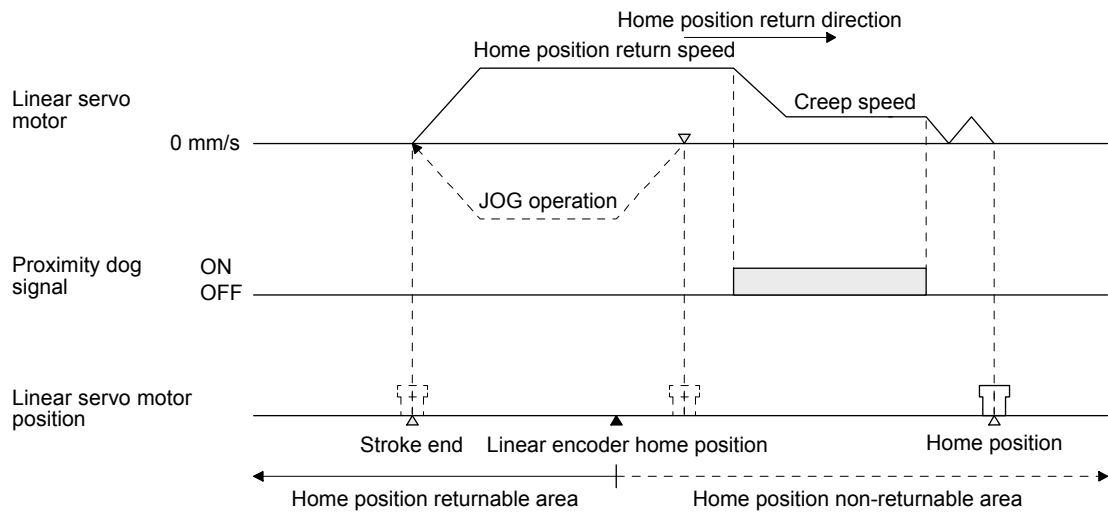

14. USING A LINEAR SERVO MOTOR

(2) Absolute position linear encoder

| |
|---------------------------------------------------------------------------------------------------------------------|
| POINT |
| <ul style="list-style-type: none"> ● The data set type home position return can also be carried out. |

When an absolute linear encoder is used, the reference home position is the position per 1048576 pulses (changeable with the third digit of [Pr. PL01]) with reference to the linear encoder home position (absolute position data = 0).

In the case of a proximity dog type home position return, the nearest reference home position after proximity dog off is the home position. The linear encoder home position can be set in any position. LZ (Encoder Z-phase pulse) cannot be used.

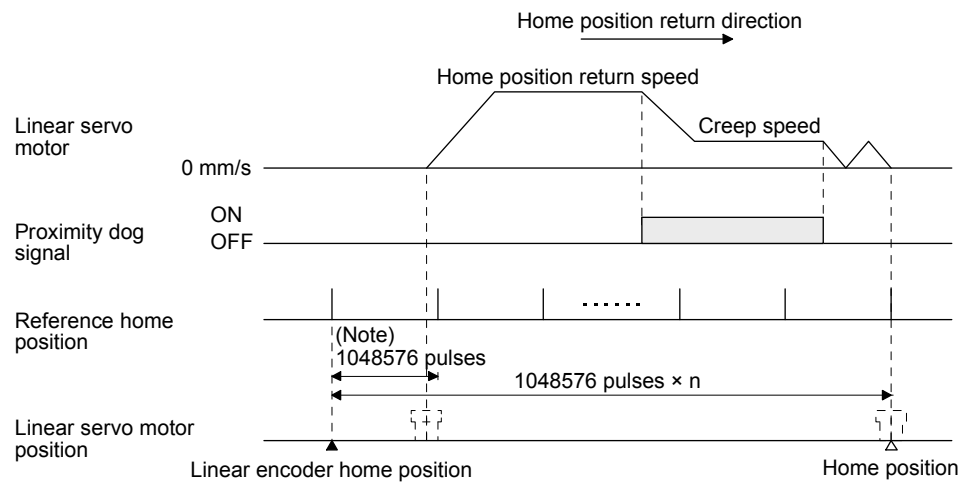

Note. Changeable with [Pr. PL01].

14.3.4 Test operation mode in MR Configurator2

| | |
|--|----------------------------------------------------------------------------------------------------------------------------------------------------------------------------------------------------------------------------------------------------------------------------------------------------------------------------------------|
| | <ul style="list-style-type: none"> ● The test operation mode is designed for checking servo operation. It is not for checking machine operation. Do not use this mode with the machine. Always use the linear servo motor alone. ● If the servo motor operates abnormally, use EM2 (Forced stop 2) to stop it. |
|--|----------------------------------------------------------------------------------------------------------------------------------------------------------------------------------------------------------------------------------------------------------------------------------------------------------------------------------------|

| |
|-----------------------------------------------------------------------------------------------------------------------------------------------------------------------------------------------------------------------------------------------------------------------------------------------------------------------------------------------------------------------------------------------------------------------------------------------------------------------------------------------------------------------------------------------------------------------------------------------------|
| POINT |
| <ul style="list-style-type: none"> ● The content described in this section indicates the environment where the servo amplifier and a personal computer are directly connected. ● For the MR-J4 multi-axis servo amplifier, all axes go into the test operation mode simultaneously, but only A-axis, B-axis, or C-axis can be operated. ● When the test operation mode is selected with the test operation select switch (SW2-1), the SSCNET III/H communication for the servo amplifier in the test operation mode and the following servo amplifiers is blocked. |

By using a personal computer and MR Configurator2, you can execute the positioning operation, the output signal (DO) forced output, and the program operation without connecting the servo system controller.

14. USING A LINEAR SERVO MOTOR

(1) Test operation mode type

(a) Positioning operation

Positioning operation can be performed without using the servo system controller. Use this operation with the forced stop reset. This operation can be used independently of whether the servo is on or off and whether the servo system controller is connected or not.

Exercise control on the positioning operation screen of MR Configurator2.

1) Operation pattern

| Item | Initial value | Setting range |
|----------------------------------------------|----------------------------------------------------------|----------------------------------------------------------------------------------------------------------------------------------------------------------------------------------------------------------------------------------------------|
| Travel distance [pulse] | 1048576 | 0 to 99999999 |
| Speed [mm/s] | 10 | 0 to Maximum speed |
| Acceleration/deceleration time constant [ms] | 1000 | 0 to 50000 |
| Repeat pattern | Positive direction travel → Negative direction travel | Positive direction travel → Negative direction travel Positive direction travel → Positive direction travel Negative direction travel → Positive direction travel Negative direction travel → Negative direction travel |
| Dwell time [s] | 2.0 | 0.1 to 50.0 |
| Number of repeats [time] | 1 | 1 to 9999 |

2) Operation method

| Operation | Screen control |
|---------------------------|--------------------------------------|
| Positive direction travel | Click "Positive Direction Movement". |
| Negative direction travel | Click "Reverse Direction Movement". |
| Pause | Click "Pause". |
| Stop | Click "Stop". |
| Forced stop | Click "Forced stop". |

(b) Output signal (DO) forced output

Output signals can be switched on/off forcibly independently of the servo status. This function is used for output signal wiring check, etc. Exercise control on the DO forced output screen of MR Configurator2.

(c) Program operation

Positioning operation can be performed in two or more operation patterns combined, without using the servo system controller. Use this operation with the forced stop reset. This operation may be used independently of whether the servo is on or off and whether the servo system controller is connected or not.

Exercise control on the program operation screen of MR Configurator2. For details, refer to Help of MR Configurator2.

| Operation | Screen control |
|-------------|--------------------------|
| Start | Click "Operation start". |
| Pause | Click "Pause". |
| Stop | Click "Stop". |
| Forced stop | Click "Forced stop". |

14. USING A LINEAR SERVO MOTOR

(2) Operation procedure

- 1) Turn off the power.
- 2) Turn "ON (up)" SW2-1.

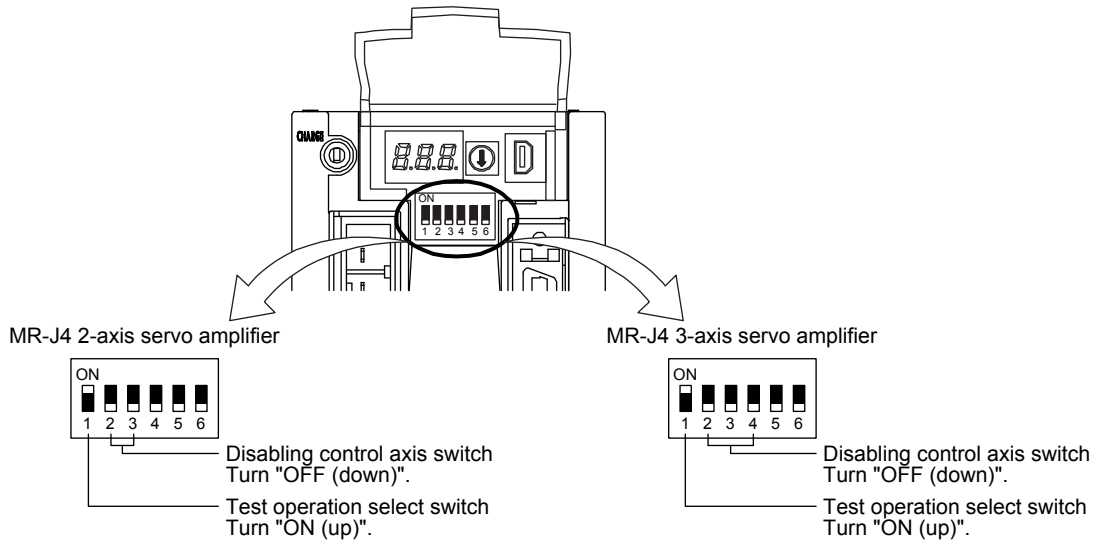

Turning "ON (up)" SW2-1 during power-on will not enable the test operation mode.

3) Turn on the servo amplifier.

When initialization is over, the display shows the following screen.

Example: MR-J4 2-axis servo amplifier

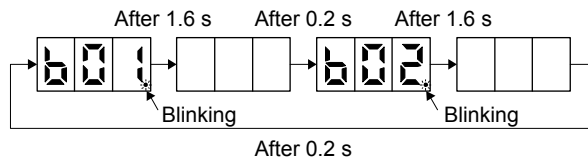

4) Start operation with the personal computer.

14. USING A LINEAR SERVO MOTOR

14.3.5 Operation from controller

The linear servo can be used with any of the following controllers.

| Servo system controller | Model |
|-------------------------|-------------------------|
| Motion controller | R_MTCPU/Q17_DSCPU |
| Simple motion module | RD77MS_/QD77MS_/LD77MS_ |

(1) Operation method

| POINT |
|------------------------------------------------------------------------------------------------------------------------------------------------------------------------------------------------------------------------------------------------------------------------------------------------------------------------------------------------------------------------|
| ● For the machine that multiple axes are connected like a tandem configuration, if you try to perform the magnetic pole detection simultaneously for multiple axes, the magnetic pole detection may not be executed. Perform the magnetic pole detection for each axis. At this time, set the axes that the magnetic pole detection is not performed for to servo-off. |

For the system using the incremental linear encoder, the magnetic pole detection is automatically performed at the first servo-on after the power-on. For this reason, when performing the positioning operation, create the sequence which surely confirms the servo-on status as the inter lock condition of the positioning command.

Also, some parameter settings and the home position return type differ according to the controller type.

14. USING A LINEAR SERVO MOTOR

(2) Servo system controller setting

(a) Setting precautions

The following parameters will be enabled by turning the servo amplifier power off and on again after the controller writes the parameters to the servo amplifier.

| Setting item | | | | Setting | |
|-------------------------------|-----------------------|----------------------------------------------------------------------------------------------|---------------------------------------------------------------------------------|----------------------------------------|----------------------------------------------------|
| | | | | Motion controller R_MTCPU/Q17_DSCPU | Simple motion module RD77MS_/QD77MS_ LD77MS_ |
| Command resolution | | | | Linear encoder resolution unit | |
| Servo amplifier setting | | | | MR-J4-B Linear | |
| Motor setting | | | | Automatic setting | |
| Parameter | No. | (Note) Symbol | Name | Initial value | |
| | PA01 | **STY | Operation mode | 1000h | 1040h |
| | PC01 | ERZ | Error excessive alarm level | 0 | Set the items as required. |
| | PC03 | *ENRS | Encoder output pulse selection | 0000h | |
| | PC27 | **COP9 | Function selection C-9 | 0000h | |
| | PL01 | **LIT1 | Linear servo motor/DD motor function selection 1 | 0301h | |
| | PL02 | **LIM | Linear encoder resolution - Numerator | 1000 | |
| | PL03 | **LID | Linear encoder resolution - Denominator | 1000 | |
| | PL04 | *LIT2 | Linear servo motor/DD motor function selection 2 | 0003h | |
| | PL05 | LB1 | Position deviation error detection level | 0 | |
| | PL06 | LB2 | Speed deviation error detection level | 0 | |
| | PL07 | LB3 | Torque/thrust deviation error detection level | 100 | |
| | PL08 | *LIT3 | Linear servo motor/DD motor function selection 3 | 0010h | |
| | PL09 | LPWM | Magnetic pole detection voltage level | 30 | |
| | PL17 | LTSTS | Magnetic pole detection - Minute position detection method - Function selection | 0000h | |
| PL18 | IDLV | Magnetic pole detection - Minute position detection method - Identification signal amplitude | 0 | | |
| Positioning control parameter | Unit setting | | | mm | |
| | Number of pulses (AP) | | | Refer to (2) (b) in this section. | |
| | Travel distance (AL) | | | | |

Note. The parameter whose symbol is preceded by * is enabled with the following conditions:

- * : After setting the parameter, power off and on the servo amplifier or reset the controller.
- ** : After setting the parameter, cycle the power of the servo amplifier.

14. USING A LINEAR SERVO MOTOR

(b) Settings of the number of pulses (AP) and travel distance (AL)

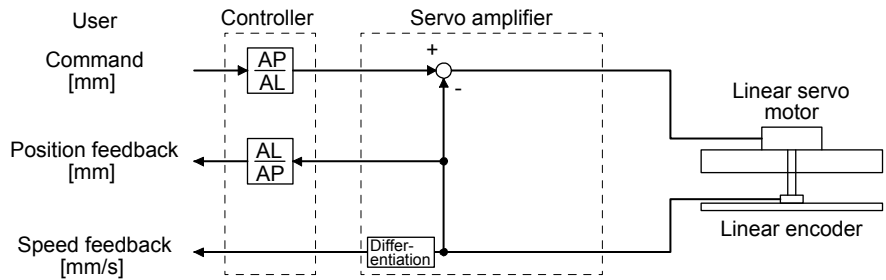

Calculate the number of pulses (AP) and travel distance (AL) of the linear encoder in the following conditions.

When the linear encoder resolution is 0.05 μm

$$\frac{\text{Number of pulses (AP) [pulse]}}{\text{Travel distance (AL) [μm]}} = \frac{1}{0.05} = \frac{20}{1}$$

14.3.6 Function

(1) Linear servo control error detection function

| |
|----------------------------------------------------------------------------------------------------------------------------------------------------------------|
| POINT |
| <p>● For the linear servo control error detection function, the position and speed deviation error detections are enabled by default. ([Pr. PL04]: __ _ 3)</p> |

If the linear servo control gets unstable for some reasons, the linear servo motor may not operate properly. To detect this state and to stop operation, the linear servo control error detection function is used as a protective function.

The linear servo control error detection function has three different detection methods: the position deviation, speed deviation, and thrust deviation. An error is detected when each method is enabled with [Pr. PL04 Linear servo motor/DD motor function selection 2]. The detection level can be changed with [Pr. PL05], [Pr. PL06], and [Pr. PL07].

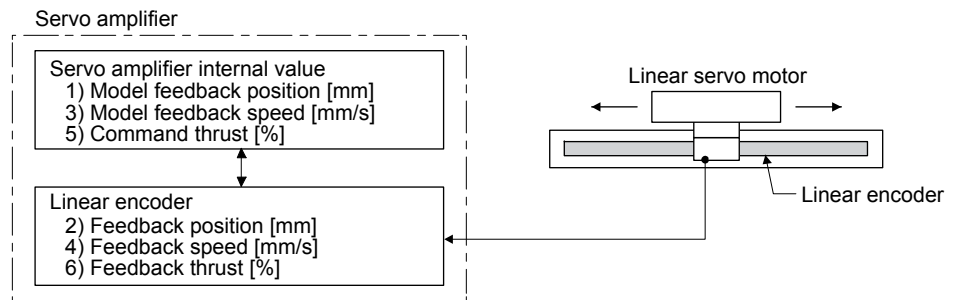
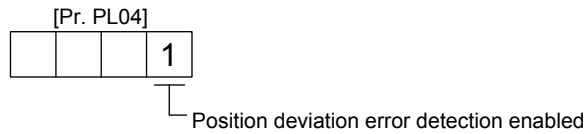

Figure 14.1 Outline of linear servo control error detection function

14. USING A LINEAR SERVO MOTOR

(a) Position deviation error detection

Set [Pr. PL04] to "___ 1" to enable the position deviation error detection.



When you compare the model feedback position (1)) and the feedback position (2)) in figure 14.1, if the deviation is more than the value of [Pr. PL05 Position deviation error detection level] (1 mm to 1000 mm), [AL. 42.1 Servo control error by position deviation] will occur and the linear servo motor will stop. The initial value of this detection level is 50 mm. Replace the set value as required.

(b) Speed deviation error detection

Set [Pr. PL04] to "___ 2" to enable the speed deviation error detection.

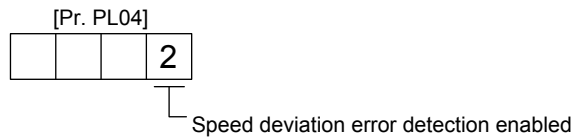

When you compare the model feedback speed (3)) and the feedback speed (4)) in figure 14.1, if the deviation is more than the value of [Pr. PL06 Speed deviation error detection level] (1 mm/s to 5000 mm/s), [AL. 42.2 Servo control error by speed deviation] will occur and the linear servo motor will stop. The initial value of this detection level is 1000 mm/s. Replace the set value as required.

(c) Thrust deviation error detection level

Set [Pr. PL04] to "___ 4" to enable the thrust deviation error detection.

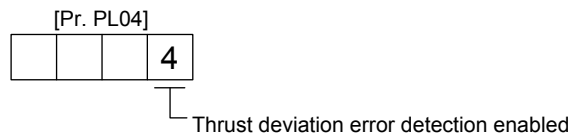

When you compare the command thrust (5)) and the feedback thrust (6)) in figure 14.1, if the deviation is more than the value of [Pr. PL07 Torque/thrust deviation error detection level] (1% to 1000%), [AL. 42.3 Servo control error by torque/thrust deviation] will occur and the linear servo motor will stop. The initial value of this detection level is 100%. Replace the set value as required.

(d) Detecting multiple deviation errors

When setting [Pr. PL04] as shown below, multiple deviation errors can be detected. For the error detection methods, refer to (1) (a), (b), (c) in this section.

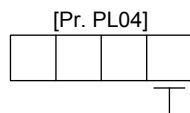

| Setting value | Position deviation error detection | Speed deviation error detection | Thrust deviation error detection |
|---------------|------------------------------------|---------------------------------|----------------------------------|
| 1 | ○ | / | / |
| 2 | / | ○ | / |
| 3 | ○ | ○ | / |
| 4 | / | / | ○ |
| 5 | ○ | / | ○ |
| 6 | / | ○ | ○ |
| 7 | ○ | ○ | ○ |

14. USING A LINEAR SERVO MOTOR

(2) Auto tuning function

| POINT |
|---------------------------------------------------------------------------------------------------------------------------------------------------------------------------------------------------------------------------------------------------------------------------------------------------------------------------------------------------------------------------------------------------------------------------------------------------------------------------------------------------------------------------------------------------|
| <ul style="list-style-type: none">● The auto tuning mode 1 may not be performed properly if the following conditions are not satisfied.<ul style="list-style-type: none">▪ Time to reach 2000 mm/s is the acceleration/deceleration time constant of 5 s or less.▪ The linear servo motor speed is 150 mm/s or higher.▪ The load to mass of the linear servo motor primary-side ratio is 100 times or less.▪ The acceleration/deceleration thrust is 10% or less of the continuous thrust. |

The auto tuning function during the linear servo motor operation is the same as that of the rotary servo motor. However, the calculation method of the load to motor mass ratio (J ratio) differs. The load to motor mass ratio (J ratio) on the linear servo motor is calculated by dividing the load mass by the mass of the linear servo motor primary side.

Example) Mass of linear servo motor primary side = 2 kg
Load mass (excluding the mass of the linear servo motor primary side) = 4 kg
Mass ratio = 4/2 = 2 times

For the parameters set by the auto tuning function, refer to chapter 6.

(3) Machine analyzer function

| POINT |
|-----------------------------------------------------------------------------------------------------------------------------------------------------------------------------------------------------------------------------------------------------------------------------------------------------------------------------------------------------|
| <ul style="list-style-type: none">● Make sure to perform the machine analyzer function after the magnetic pole detection. If the magnetic pole detection is not performed, the machine analyze function may not operate properly.● The stop position at the completion of the machine analyzer function can be any position. |

14.3.7 Absolute position detection system

When the linear servo motor is used in the absolute position detection system, an absolute position linear encoder is required. The linear encoder backs up the absolute position data. Therefore, the encoder battery case and the battery need not be installed to the servo amplifier. Additionally, [AL. 25 Absolute position erased], [AL. 92 Battery cable disconnection warning], [AL. 9F Battery warning], and [AL. E3 Absolute position counter warning] are not provided for the linear servo motor.

14. USING A LINEAR SERVO MOTOR

14.4 Characteristics

14.4.1 Overload protection characteristics

An electronic thermal relay is built in the servo amplifier to protect the linear servo motor, servo amplifier and linear servo motor power wires from overloads.

[AL. 50 Overload 1] occurs if overload operation performed is above the electronic thermal protection curve shown in fig. 14.2. [AL. 51 Overload 2] occurs if the maximum current is applied continuously for several seconds due to machine collision, etc. Use the equipment on the left-side area of the continuous or broken line in the graph.

Use the linear servo motor with 70% or less of the effective load ratio when it is in the servo lock state or in a small reciprocating motion.

This servo amplifier has solid-state linear servo motor overload protection. (The servo motor overload current (full load current) is set on the basis of 120% rated current of the servo amplifier.)

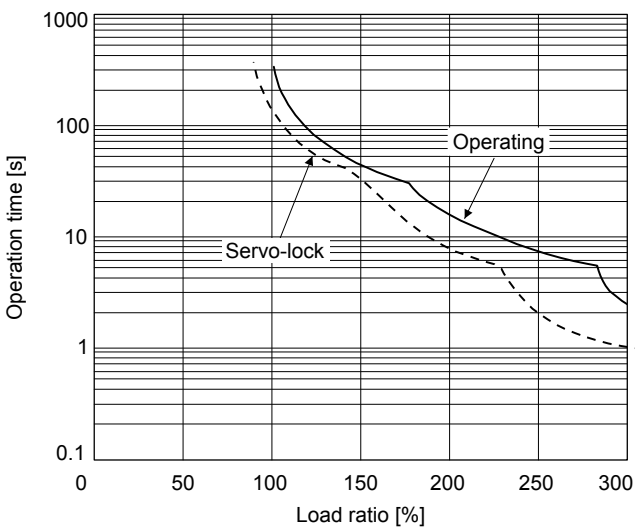

a. LM-H3 series
LM-K2 series

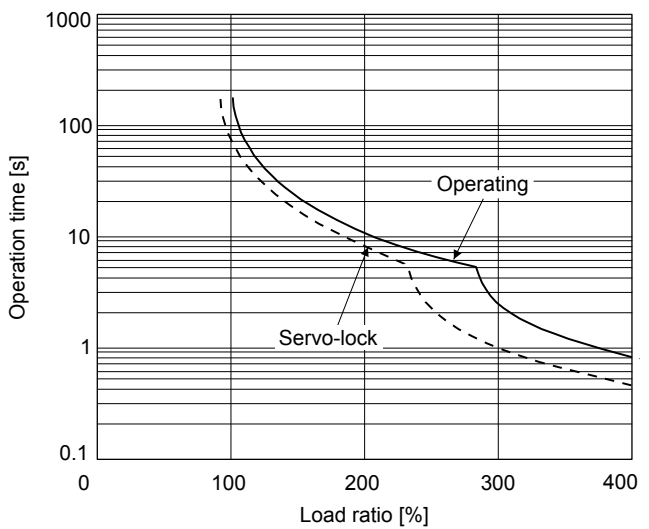

b. LM-U2 series

Fig. 14.2 Electronic thermal relay protection characteristics

14. USING A LINEAR SERVO MOTOR

14.4.2 Power supply capacity and generated loss

Calculate the generated loss and the power supply capacity of the servo amplifier under rated load from (1) and (2) in this section. The calculated value will vary depending on the number of connected linear servo motors and the capacities of the linear servo motors. For thermal design of an enclosed type cabinet, use the values calculated in consideration for the worst operating conditions. The actual amount of generated heat will be intermediate between values at rated torque and servo-off according to the duty used during operation. When the linear servo motor is run at less than the rated speed, the power supply capacity will be smaller than the calculated value, but the servo amplifier's generated heat will not change.

(1) Calculation method of power supply capacity

Calculate the power supply capacity for one servo amplifier from tables 14.1 and 14.2.

Table 14.1 Power supply capacity for one servo amplifier at rated output

| Servo amplifier | (Note) Power supply capacity [kVA] |
|-----------------|----------------------------------------------------------------------------------|
| MR-J4W2-22B | Total power supply capacity of connected linear servo motors ((A) in table 14.2) |
| MR-J4W2-44B | |
| MR-J4W2-77B | |
| MR-J4W2-1010B | |
| MR-J4W3-222B | |
| MR-J4W3-444B | |

Note. The power supply capacity will vary according to the power supply impedance. This value is applicable when the power factor improving reactor is not used.

Table 14.2 Servo amplifier power supply capacity for one linear servo motor

| Linear servo motor | Power supply capacity [kVA] (A) |
|--------------------|---------------------------------|
| LM-H3P2A-07P-BSS0 | 0.9 |
| LM-H3P3A-12P-CSS0 | 0.9 |
| LM-H3P3B-24P-CSS0 | 1.3 |
| LM-H3P3C-36P-CSS0 | 1.9 |
| LM-H3P7A-24P-ASS0 | 1.3 |
| LM-U2PAB-05M-0SS0 | 0.5 |
| LM-U2PAD-10M-0SS0 | 0.9 |
| LM-U2PAF-15M-0SS0 | 0.9 |
| LM-U2PBB-07M-1SS0 | 0.5 |
| LM-U2PBD-15M-1SS0 | 1.0 |
| LM-U2PBF-22M-1SS0 | 1.3 |
| LM-K2P1A-01M-2SS1 | 0.9 |
| LM-K2P2A-02M-1SS1 | 1.3 |

Calculate the power supply capacity with equation 10.1 in (1) in section 10.2.

14. USING A LINEAR SERVO MOTOR

(2) Calculation method of the amount of heat generated by the servo amplifier

Calculate the amount of heat generated by one servo amplifier from tables 14.3 and 14.4.

Table 14.3 Amount of heat generated by one servo amplifier at rated output

| Servo amplifier | (Note) Servo amplifier-generated heat [W] | |
|-----------------|-------------------------------------------|---------------------------------------------------------------------------------------------------------------------------------------------------------------------------------------------|
| | With servo-off (C) | At rated output |
| MR-J4W2-22B | 20 | Sum of the total amount of heat generated by the servo amplifier for each linear servo motor ((B) in table 14.4) and the amount of heat generated by the servo amplifier with servo-off (C) |
| MR-J4W2-44B | 20 | |
| MR-J4W2-77B | 20 | |
| MR-J4W2-1010B | 20 | |
| MR-J4W3-222B | 20 | |
| MR-J4W3-444B | 25 | |

Note. Heat generated during regeneration is not included in the servo amplifier-generated heat. To calculate heat generated by the regenerative option, refer to section 11.2.

Table 14.4 Amount of heat generated by one servo amplifier for one linear servo motor

| Servo motor | Servo amplifier-generated heat [W] (B) |
|-------------------|----------------------------------------|
| LM-H3P2A-07P-BSS0 | 35 |
| LM-H3P3A-12P-CSS0 | 35 |
| LM-H3P3B-24P-CSS0 | 50 |
| LM-H3P3C-36P-CSS0 | 75 |
| LM-H3P7A-24P-ASS0 | 50 |
| LM-U2PAB-05M-0SS0 | 25 |
| LM-U2PAD-10M-0SS0 | 35 |
| LM-U2PAF-15M-0SS0 | 35 |
| LM-U2PBB-07M-1SS0 | 25 |
| LM-U2PBD-15M-1SS0 | 40 |
| LM-U2PBF-22M-1SS0 | 50 |
| LM-K2P1A-01M-2SS1 | 35 |
| LM-K2P2A-02M-1SS1 | 50 |

Calculate the amount of heat generated by the servo amplifier with equation 10.2 in (2) in section 10.2.

14. USING A LINEAR SERVO MOTOR

CAUTION

- The coasting distance is a theoretically calculated value which ignores the running load such as friction. The calculated value is considered to be longer than the actual distance. However, if an enough braking distance is not provided, a moving part may crash into the stroke end, which is very dangerous. Install the anti-crash mechanism such as an air brake or an electric/mechanical stopper such as a shock absorber to reduce the shock of moving parts. No linear servo motor with an electromagnetic brake is available.

14.4.3 Dynamic brake characteristics

POINT

- Do not use dynamic brake to stop in a normal operation as it is the function to stop in emergency.
- For a machine operating at the recommended load to motor mass ratio or less, the estimated number of usage times of the dynamic brake is 1000 times while the machine decelerates from the rated speed to a stop once in 10 minutes.
- Be sure to enable EM1 (Forced stop 1) after the linear servo motor stops when using EM1 (Forced stop 1) frequently in other than emergency.

The approximate coasting distance from when the dynamic brake is activated until when the linear servo motor stops can be calculated with the equation below.

$$L_{max} = V_0 \cdot (0.03 + M \cdot (A + B \cdot V_0^2))$$

L_{max} : Coasting distance of the machine [m]

V_0 : Speed when the brake is activated [m/s]

M: Full mass of the moving part [kg]

A: Coefficient (Refer to the following tables.)

B: Coefficient (Refer to the following tables.)

| Linear servo motor | Coefficient A | Coefficient B |
|--------------------|-----------------------|-----------------------|
| LM-H3P2A-07P-BSS0 | 7.15×10^{-3} | 2.94×10^{-3} |
| LM-H3P3A-12P-CSS0 | 2.81×10^{-3} | 1.47×10^{-3} |
| LM-H3P3B-24P-CSS0 | 7.69×10^{-3} | 2.27×10^{-4} |
| LM-H3P3D-48P-CSS0 | 1.02×10^{-3} | 2.54×10^{-4} |
| LM-H3P7A-24P-ASS0 | 7.69×10^{-3} | 2.14×10^{-4} |

| Linear servo motor | Coefficient A | Coefficient B |
|--------------------|-----------------------|-----------------------|
| LM-K2P1A-01M-2SS1 | 5.36×10^{-3} | 6.56×10^{-3} |
| LM-K2P2A-02M-1SS1 | 2.49×10^{-2} | 1.02×10^{-3} |

| Linear servo motor | Coefficient A | Coefficient B |
|--------------------|-----------------------|-----------------------|
| LM-U2PAB-05M-0SS0 | 5.72×10^{-2} | 1.72×10^{-4} |
| LM-U2PAD-10M-0SS0 | 2.82×10^{-2} | 8.60×10^{-5} |
| LM-U2PAF-15M-0SS0 | 1.87×10^{-2} | 5.93×10^{-5} |
| LM-U2PBB-07M-1SS0 | 3.13×10^{-2} | 1.04×10^{-4} |
| LM-U2PBD-15M-1SS0 | 1.56×10^{-2} | 5.18×10^{-5} |
| LM-U2PBF-22M-1SS0 | 4.58×10^{-2} | 1.33×10^{-5} |

14. USING A LINEAR SERVO MOTOR

14.4.4 Permissible load to motor mass ratio when the dynamic brake is used

Use the dynamic brake under the load to motor mass ratio indicated in the following table. If the load to motor mass ratio is higher than this value, the dynamic brake may burn. If there is a possibility that the load inertia moment may exceed the value, contact your local sales office.

The values of the permissible load to motor mass ratio in the table are the values when the linear servo motor is used at the maximum speed.

| Linear servo motor | Permissible load to motor mass ratio [multiplier] |
|--------------------|------------------------------------------------------|
| LM-H3 series | 40 |
| LM-U2 series | 100 |
| LM-K2 series | 50 |

When actual speed does not reach the maximum speed of the servo motor, calculate the permissible load to motor mass ratio at the time of using the dynamic brake by the following equation. (The upper limit is 300 times.)

Permissible load to motor mass ratio at the time of using the dynamic brake = Value in the table × (Servo motor maximum speed²/Actual using speed²)

For example, when an actual using speed is 2 m/s or less for the LM-H3P2A-07P motor (maximum speed: 3.0 m/s), the equation will be as follows. Permissible load to motor mass ratio at the time of using the dynamic brake = $40 \times 3^2/2^2 = 90$ [times]

15. USING A DIRECT DRIVE MOTOR

15. USING A DIRECT DRIVE MOTOR



CAUTION

●When using the direct drive motor, read the "Direct Drive Motor Instruction Manual".

| POINT |
|--------------------------------------------------------------------------------------------------------------------------------|
| ●Refer to section 1.3.3 for the software version of the servo amplifier that is compatible with the direct drive servo system. |
| ●The number of connectable direct drive motors is limited for one MR-BT6VCASE battery case. Refer to section 11.3 for details. |
| ●The MR-J4W2-0303B6 servo amplifier is not compatible with direct drive motor. |

15.1 Functions and configuration

15.1.1 Summary

The fields of semiconductor/LCD manufacturing systems, mounters, and others have strong demands for high accuracy and efficiency. Therefore, the number of systems using a direct drive motor for a drive axis has been increasing. The direct drive servo system includes the following features.

(1) Performance

- (a) The direct drive servo system ensures the high-rigidity and the high-torque. A high-resolution encoder enables the high-accuracy control.
- (b) The high-resolution encoder contributes to the high-indexer accuracy.
- (c) Since reducer is no longer required, no backlash occurs. In addition, the settling time is reduced, and the high-frequency operation is enabled.
- (d) Since reducer is no longer required, the motor does not deteriorate with time by reducer.

(2) Mechanism

- (a) The motor's low profile design contributes to compact moving part of the machine and a low center of gravity for enhanced equipment stability.
- (b) The motor has an inner rotor with hollow shaft which enables cables and pipes to be passed through.
- (c) Lubrication and the maintenance due to abrasion are not required.

15. USING A DIRECT DRIVE MOTOR

The following shows the differences between the direct drive motor and the rotary servo motor.

| Category | Item | Differences | | Remark |
|------------------------------------|-----------------------------------------------------------------------------------------------|----------------------------------------|--------------------------------|-------------------------------------------------------------------------------------------------------------------------------------------------------------------------------------------------------------|
| | | Direct drive motor | Rotary servo motor | |
| External I/O signal | FLS (Upper stroke limit), RLS (Lower stroke limit) | Required (for magnetic pole detection) | Not required | Automatically turns on in the parameter setting. |
| Motor pole adjustment | Magnetic pole detection | Required | Not required (default setting) | Automatically executed at the first servo-on after the power is turned on. For the absolute position detection system, [Pr. PL01] can disable the magnetic pole detection. (Refer to (3) (b) of 15.3.2.) |
| Absolute position detection system | Absolute position encoder battery 1 battery case (MR-BT6VCASE) and 5 batteries (MR-BAT6V1) | Required | Required | The number of connectable direct drive motors is limited. Refer to section 11.3 for details. |
| | Absolute position storage unit (MR-BTAS01) | Required | Not required | |

15. USING A DIRECT DRIVE MOTOR

15.1.2 Servo system with auxiliary equipment

CAUTION ●Connecting a direct drive motor for different axis to the CNP3A, CNP3B, or CNP3C connector may cause a malfunction.

POINT

- Equipment other than the servo amplifier and direct drive motor are optional or recommended products.
- When using the direct drive motor, set [Pr. PA01] to " _ _ 6 _".

The configuration diagram is an example of MR-J4W3-222B. When using the other servo amplifiers, the configuration will be the same as rotary servo motors except for connections of direct drive motors. Refer to section 1.7 depending on servo amplifiers you use.

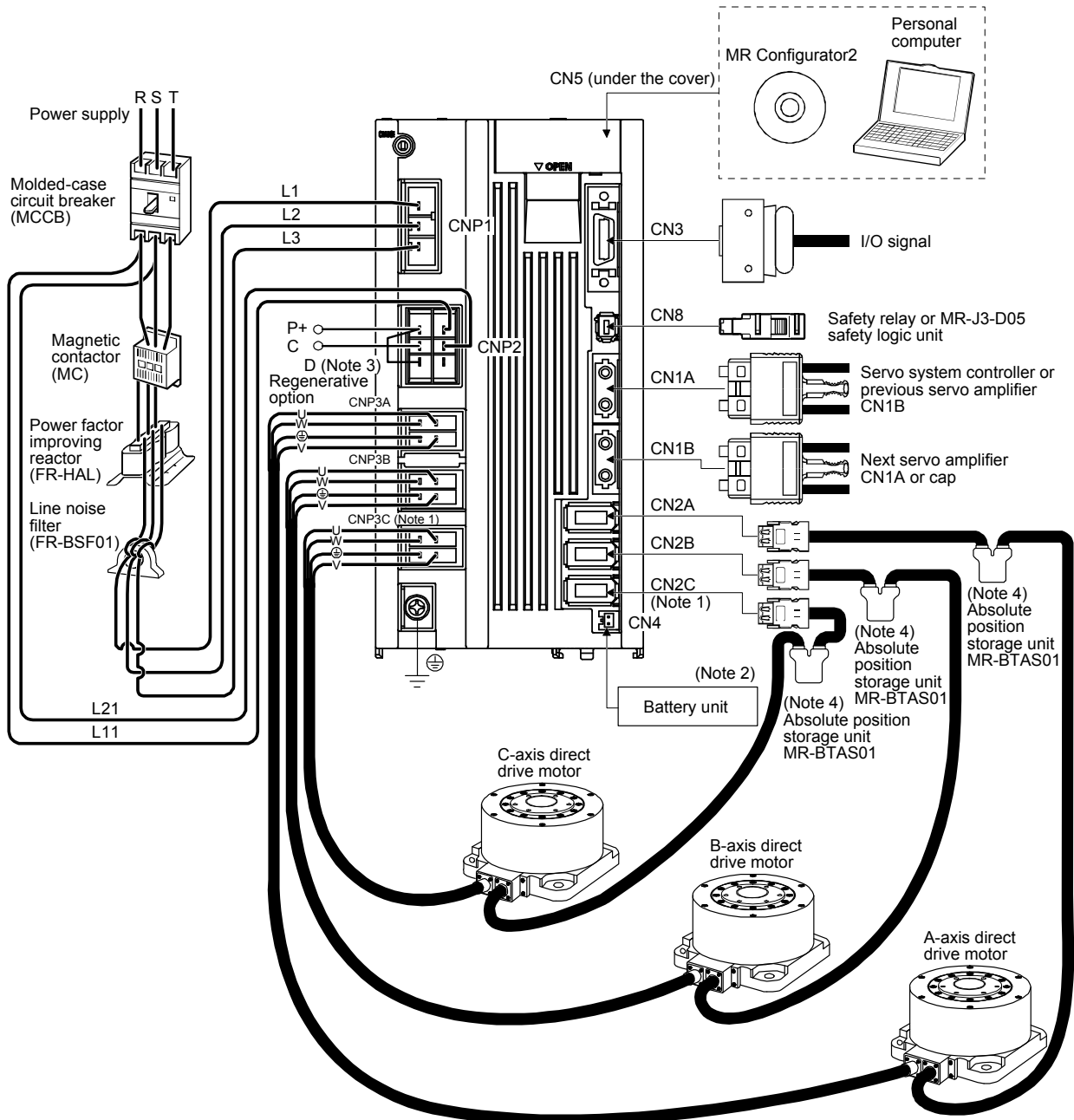

15. USING A DIRECT DRIVE MOTOR

Note 1. This figure shows the 3-axis servo amplifier.

2. The battery unit consists of an MR-BT6VCASE battery case and five MR-BAT6V1 batteries. The battery unit is used in the absolute position detection system. (Refer to chapter 12.)
3. Always connect P+ and D. When using the regenerative option, refer to section 11.2.
4. The absolute position storage unit is used for the absolute position detection system.

15.2 Signals and wiring



WARNING

- Any person who is involved in wiring should be fully competent to do the work.
- Before wiring, turn off the power and wait for 15 minutes or more until the charge lamp turns off. Then, confirm that the voltage between P+ and N- is safe with a voltage tester and others. Otherwise, an electric shock may occur. In addition, when confirming whether the charge lamp is off or not, always confirm it from the front of the servo amplifier.
- Ground the servo amplifier and the direct drive motor securely.
- Do not attempt to wire the servo amplifier and the direct drive motor until they have been installed. Otherwise, it may cause an electric shock.
- The cables should not be damaged, stressed, loaded, or pinched. Otherwise, it may cause an electric shock.
- To avoid an electric shock, insulate the connections of the power supply terminals.



CAUTION

- Wire the equipment correctly and securely. Otherwise, the direct drive motor may operate unexpectedly, resulting in injury.
- Connect cables to the correct terminals. Otherwise, a burst, damage, etc. may occur.
- Ensure that polarity (+/-) is correct. Otherwise, a burst, damage, etc. may occur.
- The surge absorbing diode installed to the DC relay for control output should be fitted in the specified direction. Otherwise, the emergency stop and other protective circuits may not operate.

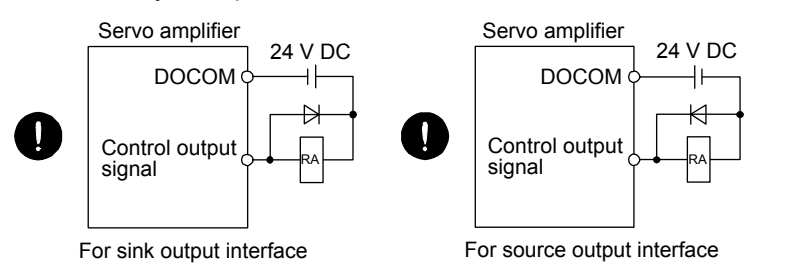

For sink output interface

For source output interface

- Use a noise filter, etc. to minimize the influence of electromagnetic interference. Electromagnetic interference may be given to the electronic equipment used near the servo amplifier.
- Do not install a power capacitor, surge killer, or radio noise filter (FR-BIF option) with the power wire of the direct drive motor.
- When using the regenerative resistor, switch power off with the alarm signal. Otherwise, a transistor fault or the like may overheat the regenerative resistor, causing a fire.
- Do not modify the equipment.

15. USING A DIRECT DRIVE MOTOR

- Connect the servo amplifier power output (U/V/W) to the power input of the direct drive motor (U/V/W) directly. Do not let a magnetic contactor, etc. intervene. Otherwise, it may cause a malfunction.

CAUTION

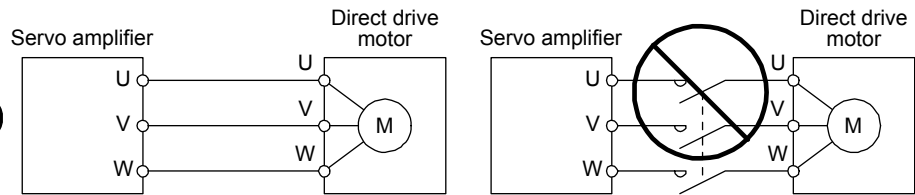

- Connecting a servo motor for different axis to the CNP3A, CNP3B, or CNP3C connector may cause a malfunction.
- Before wiring, switch operation, etc., eliminate static electricity. Otherwise, it may cause a malfunction.

This chapter does not describe the following items. For details of the items, refer to each section of the detailed description field.

| Item | Detailed explanation |
|---------------------------------------------------|----------------------|
| Input power supply circuit | Section 3.1 |
| Explanation of power supply system | Section 3.3 |
| Signal (device) explanations | Section 3.5 |
| Alarm occurrence timing chart | Section 3.7 |
| Interfaces | Section 3.8 |
| SSCNET III cable connection | Section 3.9 |
| Grounding | Section 3.11 |
| Switch setting and display of the servo amplifier | Section 4.3 |
| Parameters | Chapter 5 |
| Troubleshooting | Chapter 8 |

15.3 Operation and functions

POINT

- When using the direct drive motor, set [Pr. PA01] to " __ 6 _".
- For the test operation, refer to section 4.4.
- The Z-phase pulse of the direct drive motor must be turned on after power-on. When the machine configuration does not allow one or more revolution of the direct drive motor, install the direct drive motor so that the Z-phase pulse can be turned on.

15. USING A DIRECT DRIVE MOTOR

15.3.1 Startup procedure

Start up the direct drive servo system in the following procedure.

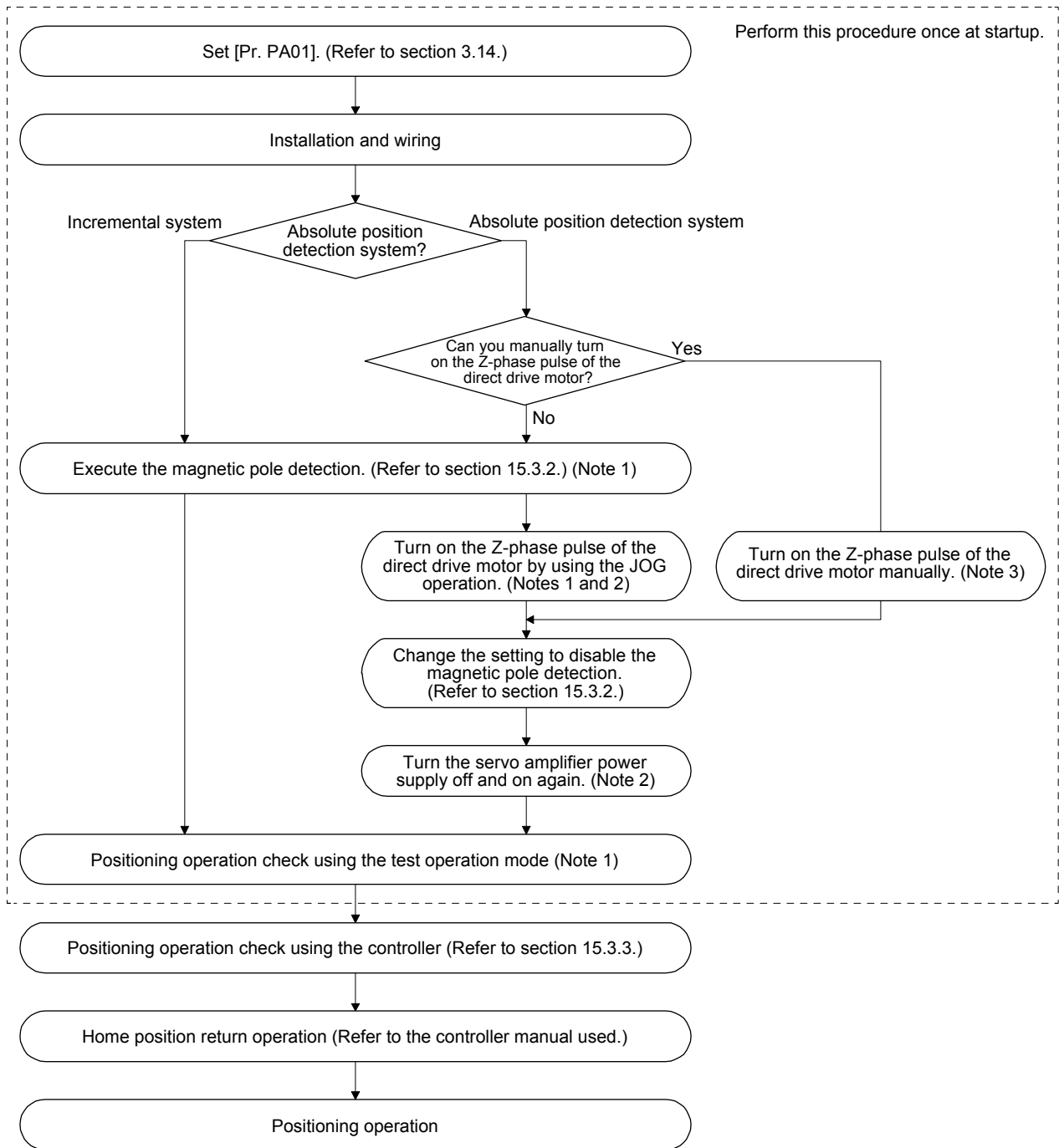

Note 1. Use MR Configurator2.

2. For the absolute position detection system, always turn on the Z-phase pulse of the direct drive motor while the servo amplifier power is on, and then turn the servo amplifier power supply off and on again. By turning off and on the power supply, the absolute position becomes confirmed. Without this operation, the absolute position will not be regained properly, and a warning will occur at the controller.

3. If the Z-phase pulse of the direct drive motor can be turned on manually, the Z-phase pulse does not have to be turned on by the magnetic pole detection or the JOG operation.

For this operation, always connect the direct drive motor encoder and the servo amplifier, and turn on only the control circuit power supply of the servo amplifier (L11/L21) (turn off the main circuit power supply L1, L2, and L3). Perform this operation by considering the safety.

15. USING A DIRECT DRIVE MOTOR

15.3.2 Magnetic pole detection

| POINT |
|-----------------------------------------------------------------------------------------------------------------------------------------------------------------------------------------------------------------------------------------------------------------------------------------------------------------------------------------------------------------------------------------------------------------------------------------------------------------------------------------------------------------------------------------------------------------------------------------------------------------------------------------------------------------------------------------------------------------------------------------------------------------------------------------------------------------------------------------------------------------------------------------------------------------------------------------------------------|
| <ul style="list-style-type: none">● The magnetic pole detection is not required for the configured absolute position detection system where the Z-phase pulse of the direct drive motor can be turned on manually. For this operation, always connect the direct drive motor encoder and the servo amplifier and turn on the control circuit power supply of the servo amplifier. Perform this operation by considering the safety.● When performing a magnetic pole detection without using FLS (Upper stroke limit) and RLS (Lower stroke limit), set [Pr. PL08 Linear servo motor/DD motor function selection 3] to "_ 1 _ _" to disable FLS and RLS.● Set [Pr. PE47 Torque offset] to "0 (initial value)" before executing the magnetic pole detection.● For the magnetic pole detection of vertical axis with direct drive motors, refer to section 2.1 of "Direct Drive Motor Instruction Manual". |

Before the positioning operation of the direct drive motor, make sure to perform the magnetic pole detection.
Before starting up the equipment, perform the test operation (positioning operation) of MR Configurator2.

15. USING A DIRECT DRIVE MOTOR

(1) Magnetic pole detection method by using MR Configurator2

The following shows the magnetic pole detection procedure by using MR Configurator2.

(a) Magnetic pole detection by the position detection method

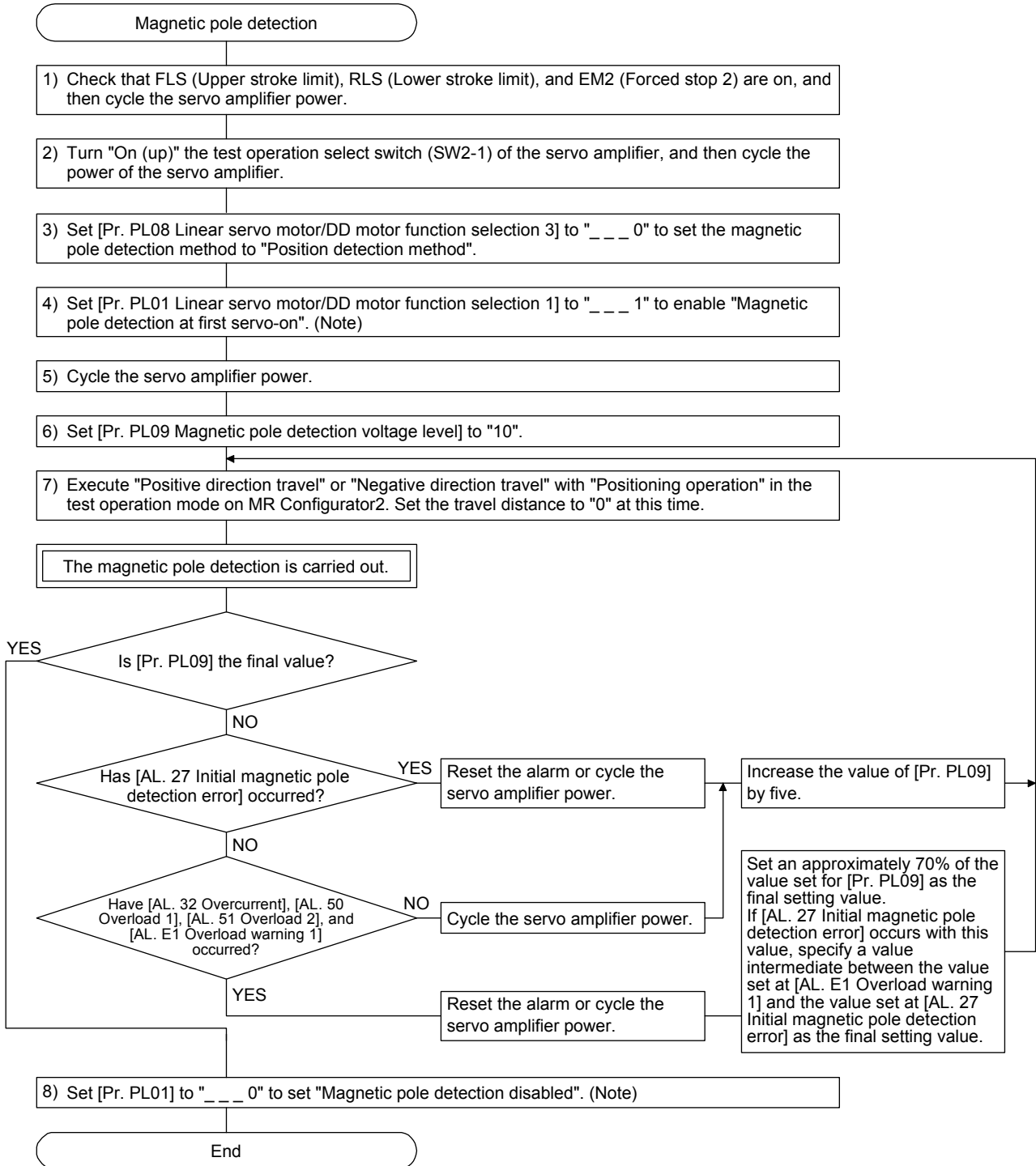

Note. For the incremental system, the [Pr. PL01] setting is not required.

15. USING A DIRECT DRIVE MOTOR

(b) Magnetic pole detection by the minute position detection method

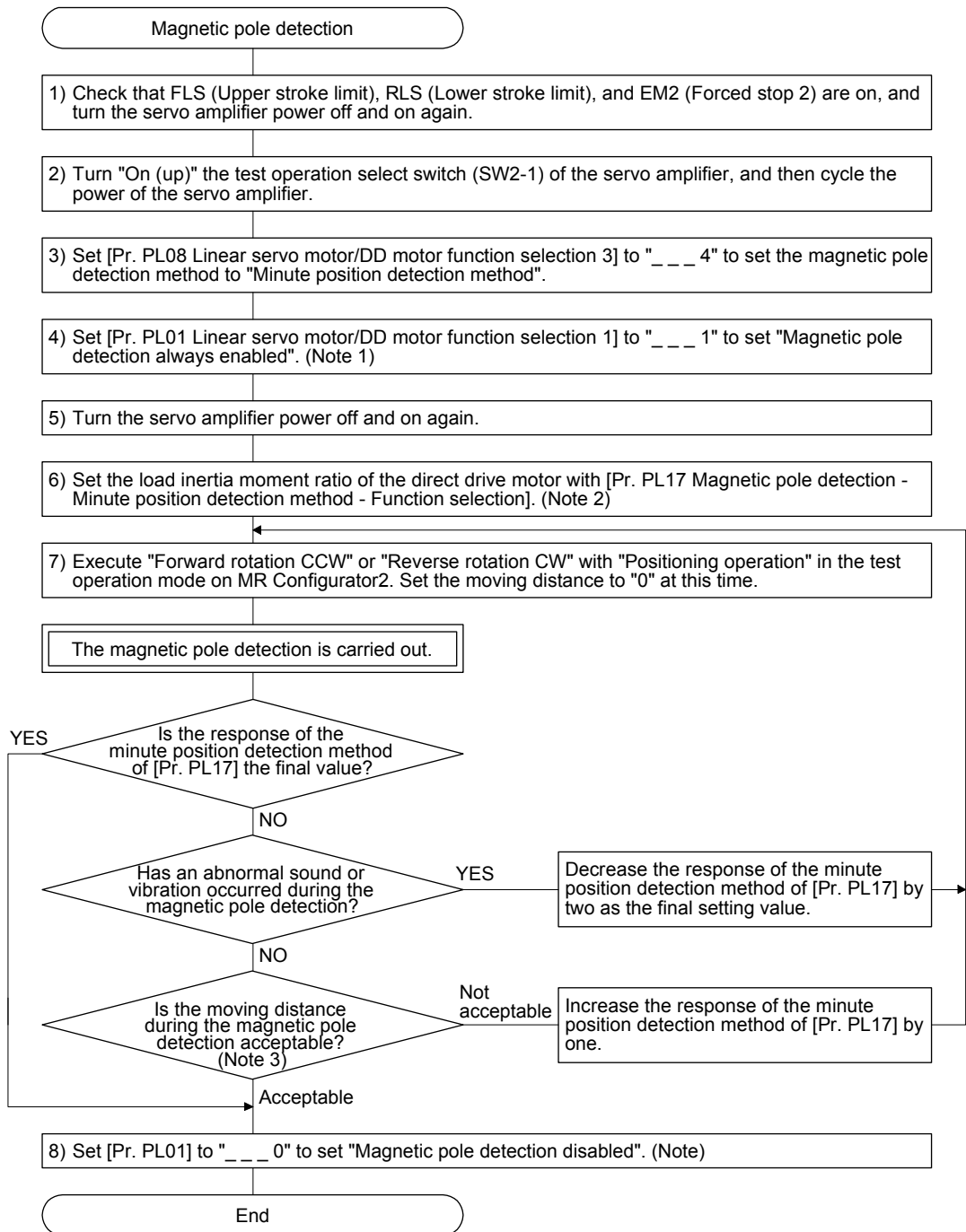

- Note
1. For the incremental system, the [Pr. PL01] setting is not required.
 2. If the load to direct drive motor inertia ratio is unknown, perform the magnetic pole detection by the position detection method, and then perform the auto tuning to set an estimated value.
 3. For the magnetic pole detection by the minute position detection method, the maximum rotation angle at the magnetic pole detection must be five degrees or less. To shorten the travel distance, increase the response by the minute position detection method in [Pr. PL17].

15. USING A DIRECT DRIVE MOTOR

- (c) State transition of the servo amplifier display (3-digit, 7-segment LED) at the magnetic pole detection
 When the magnetic pole detection with MR Configurator2 is normally executed, the servo amplifier display (3-digit, 7-segment LED) shows the state as below.

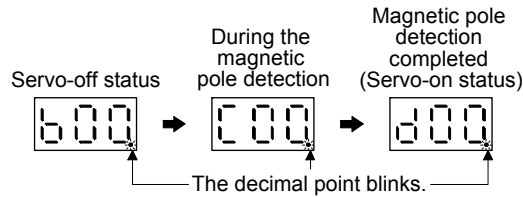

- (2) Preparation for the magnetic pole detection

| POINT |
|------------------------------------------------------------------------------------------------------------------------------------------------------------------------------------------------------------------------------------------------------------------------------|
| <ul style="list-style-type: none"> ● When the test operation mode is selected with the test operation select switch (SW2-1), the SSCNET III/H communication for the servo amplifier in the test operation mode and the following servo amplifiers is blocked. |

For the magnetic pole detection, use the test operation mode (positioning operation) of MR Configurator2. Turn off the servo amplifier power, and set the test operation select switch (SW2-1) and the disabling control axis switch (SW2-2, SW2-3, and SW2-4) as shown below. Turning on the power enables the test operation mode.

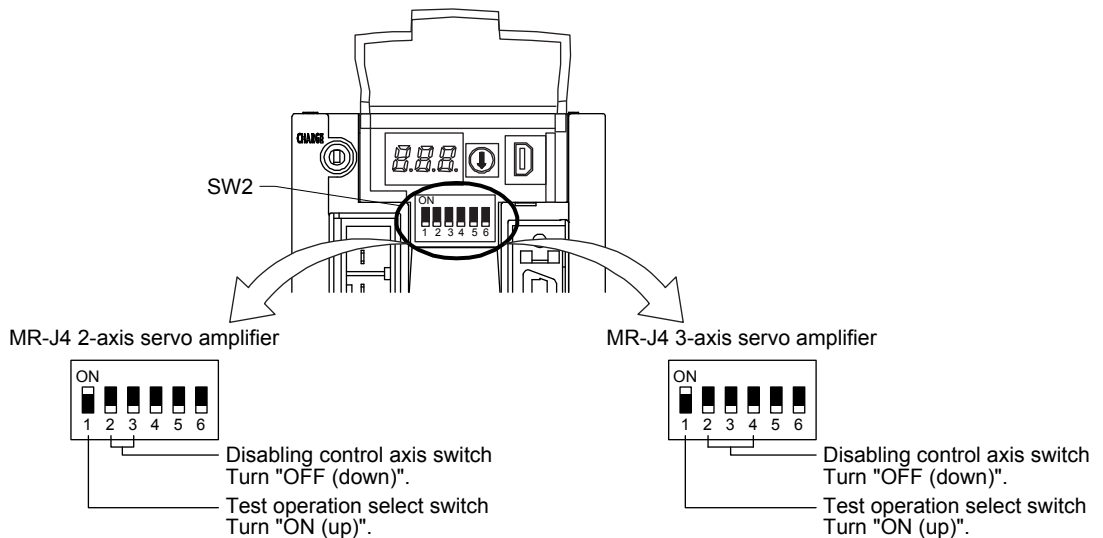

15. USING A DIRECT DRIVE MOTOR

(3) Operation at the magnetic pole detection

WARNING ● Note that the magnetic pole detection automatically starts simultaneously with the turning-on of the servo-on command.

CAUTION ● If the magnetic pole detection is not executed properly, the direct drive motor may operate unexpectedly.

| POINT |
|---------------------------------------------------------------------------------------------------------------------------------------------------------------------------------------------------------------------------------------------------------------------------------------------------------------------------------------------------------------------------------------------------------------------------------------------------------------------------------------------------------------------------------------------------------------------------------------------------------------------------------------------------------------------------------------------------------------------------------------------------------------------------------------------------------------------------------------------------------------------------------------------------------------------------------------------------------------------------------------------------------------------------------------------------------------------------------------------------------------------------------------|
| <ul style="list-style-type: none"> ● Establish the machine configuration using FLS (Upper stroke limit) and RLS (Lower stroke limit). Otherwise, the machine may be damaged due to a collision. ● At the magnetic pole detection, whether the motor rotates in the forward or reverse direction is unpredictable. ● Depending on the setting value of [Pr. PL09 Magnetic pole detection voltage level], an overload, overcurrent, magnetic pole detection alarm, or others may occur. ● When performing the positioning operation from a controller, use the sequence which confirms the normal completion of the magnetic pole detection and the servo-on status, then outputs the positioning command. If the controller outputs the positioning command before RD (Ready) turns on, the command may not be accepted or a servo alarm may occur. ● After the magnetic pole detection, check the positioning accuracy with the test operation (positioning operation function) of MR Configurator2. ● The accuracy of the magnetic pole detection improves with no load. |

(a) Incremental system

| POINT |
|------------------------------------------------------------------------------------------------------------------------------------------------------------|
| <ul style="list-style-type: none"> ● For the incremental system, the magnetic pole detection is required every time the power is turned on. |

By turning on the servo-on command from the controller after the power-on, the magnetic pole detection is automatically carried out. Therefore, there is no need to set the parameter (first digit of [Pr. PL01]) for executing the magnetic pole detection.

1) Timing chart

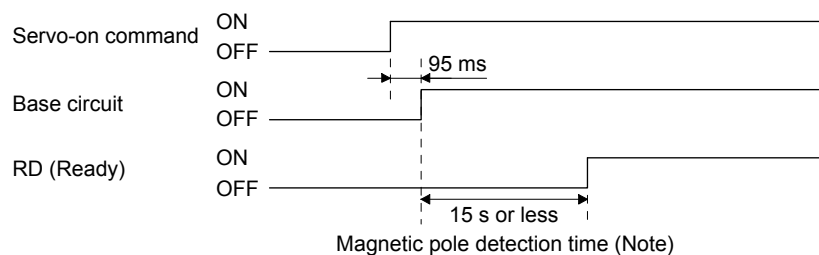

Note. The magnetic pole detection time indicates the operation time when FLS (Upper stroke limit) and RLS (Lower stroke limit) are on.

15. USING A DIRECT DRIVE MOTOR

2) Direct drive motor movement (when FLS and RLS are on)

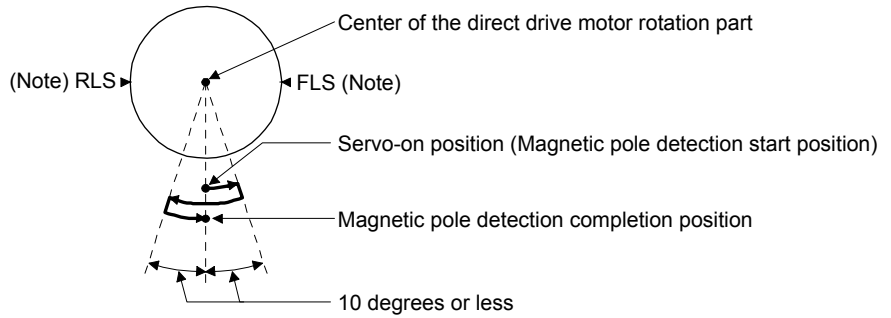

Note. When you turn off FLS (Upper stroke limit) or RLS (Lower stroke limit) during the magnetic pole detection, the magnetic pole detection is carried on to the opposite direction. When FLS and RLS are off, [AL. 27 Initial magnetic pole detection error] occurs.

3) Direct drive motor movement (when FLS or RLS is off)

When FLS or RLS is off at servo-on, the magnetic pole detection is carried out as follows.

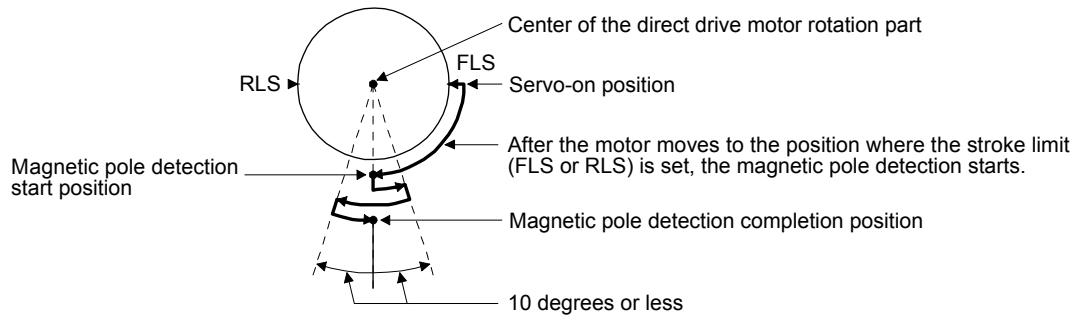

(b) Absolute position detection system

| POINT |
|----------------------------------------------------------------------------------------------------------------------------------------------------------------------------------------------------------------------------------------------------------------------------------------------------------------------------------------------------------------------------------------------------------------------------------------------------------------------------------------------------------------------------------------------------------------------------------------------------------------------------------------------------------------------------------------------------------------------------------------------------------|
| <ul style="list-style-type: none"> ● The magnetic pole detection is required in the following timings. <ul style="list-style-type: none"> ▪ When the system is set up (at the first startup of equipment) ▪ When the Z-phase pulse of the direct drive motor is not turned on at the system setup (When the Z-phase pulse of the direct drive motor can be turned on manually, the magnetic pole detection is not required.) ▪ After a direct drive motor is replaced ▪ When [AL. 25 Absolute position erased] has occurred ● Turn on the Z-phase pulse of the direct drive motor in JOG operation from the controller after the magnetic pole detection. |

Perform the magnetic pole detection in the following procedure.

- 1) Set [Pr. PL01 Linear servo motor/DD motor function selection 1] to " _ _ _ 1" (Magnetic pole detection at first servo-on).

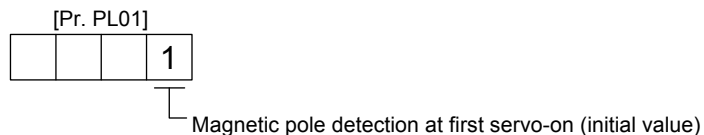

15. USING A DIRECT DRIVE MOTOR

- 2) Execute the magnetic pole detection. (Refer to (2) (a) 1), 2) in this section.)
- 3) After the completion of the magnetic pole detection, change [Pr. PL01] to "___0" (Magnetic pole detection disabled).

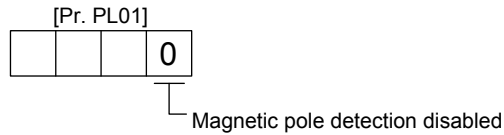

After the magnetic pole detection, by turning on the Z-phase pulse of the direct drive motor in JOG operation and by disabling the magnetic pole detection function with [Pr. PL01], the magnetic pole detection after each power-on is not required.

(4) Magnetic pole detection method setting

Set the magnetic pole detection method using the first digit of [Pr. PL08] (Magnetic pole detection method selection).

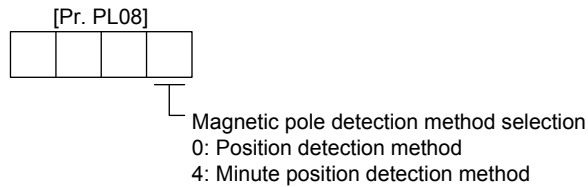

(5) Setting of the magnetic pole detection voltage level by the position detection method

For the magnetic pole detection by the position detection method, set the voltage level with [Pr. PL09 Magnetic pole detection voltage level]. For the magnetic pole detection by the minute position detection method, the voltage level setting is not required.

(a) Guideline of parameter settings

Set the parameters by referring to the following table.

| [Pr. PL09] setting (Guide value) | Small ← Medium → Large (10 or less (initial value) 50 or more) | |
|-------------------------------------|-------------------------------------------------------------------|-------------------|
| Servo status | | |
| Torques required for operation | Small | Large |
| Overload, overcurrent alarm | Seldom occurs | Frequently occurs |
| Magnetic pole detection alarm | Frequently occurs | Seldom occurs |
| Magnetic pole detection accuracy | Low | High |

(b) Setting procedure

- 1) Perform the magnetic pole detection, and increase the setting value of [Pr. PL09 Magnetic pole detection voltage level] until [AL. 50 Overload 1], [AL. 51 Overload 2], [AL. E1 Overload warning 1], and [AL. EC Overload warning 2] occur. Increase the setting value by five as a guide value. When these alarms and warnings occur during the magnetic pole detection by using MR Configurator2, the test operation of MR Configurator2 automatically completes and the servo-off status is established.

15. USING A DIRECT DRIVE MOTOR

- 2) Specify the setting value that is an approximately 70% of the value set when [AL. 50 Overload 1], [AL. 51 Overload 2], [AL. E1 Overload warning 1], and [AL. EC Overload warning 2] occurred as the final setting value. However, if [AL. 27 Initial magnetic pole detection error] occurs with this value, specify a value intermediate between the value set at [AL. 50 Overload 1], [AL. 51 Overload 2], [AL. E1 Overload warning 1], or [AL. EC Overload warning 2] and the value set at the magnetic pole detection alarm as the final setting value.
- 3) Perform the magnetic pole detection again with the final setting value.

(c) Setting example

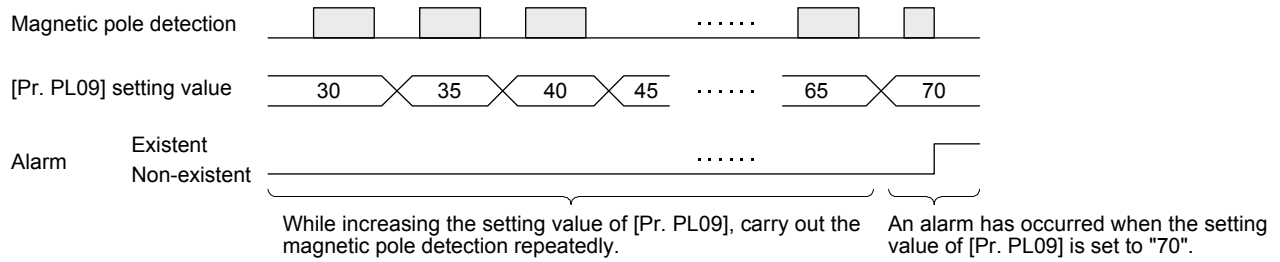

In this example, the final setting value of [Pr. PL09] is 49 (Setting value at the alarm occurrence = 70×0.7).

15. USING A DIRECT DRIVE MOTOR

15.3.3 Operation from controller

To configure the absolute position detection system by using the direct drive motor, the battery unit (one battery case (MR-BT6VCASE) and five batteries (MR-BAT6V1)) and the absolute position storage unit (MR-BTAS01) are required.

(1) Operation method

For the incremental system, the magnetic pole detection is automatically performed at the first servo-on after the power-on. For this reason, when performing the positioning operation, create the sequence which surely confirms the servo-on status as the inter lock condition of the positioning command. Also, some parameter settings and the home position return differ according to the controller type.

(2) Servo system controller setting

The following parameters will be enabled by cycling the servo amplifier power after the controller writes the parameters to the servo amplifier.

| Setting item | | | | | Set content | |
|--------------|-------------------------|------------------|----------------------------------------------------------------------------------------------|------------------|----------------------------------------|----------------------------------------------------|
| | | | | | Motion controller R_MTCPU/Q17_DSCPU | Simple motion module RD77MS_/QD77MS_ LD77MS_ |
| Parameter | Servo amplifier setting | | | | MR-J4-B DD | |
| | Motor setting | | | | Automatic setting | |
| | No. | (Note) Symbol | Name | Initial value | Set the items as required. | |
| | PA01 | **STY | Operation mode | 1000h | | |
| | PC01 | *ERZ | Error excessive alarm level | 0 | | |
| | PC03 | *ENRS | Encoder output pulse selection | 0000h | | |
| | PL01 | **LIT1 | Linear servo motor/DD motor function selection 1 | 0301h | | |
| | PL04 | *LIT2 | Linear servo motor/DD motor function selection 2 | 0003h | | |
| | PL05 | LB1 | Position deviation error detection level | 0 | | |
| | PL06 | LB2 | Speed deviation error detection level | 0 | | |
| | PL07 | LB3 | Torque/thrust deviation error detection level | 100 | | |
| | PL08 | *LIT3 | Linear servo motor/DD motor function selection 3 | 0010h | | |
| | PL09 | LPWM | Magnetic pole detection voltage level | 30 | | |
| | PL17 | LTSTS | Magnetic pole detection - Minute position detection method - Function selection | 0000h | | |
| | PL18 | IDLV | Magnetic pole detection - Minute position detection method - Identification signal amplitude | 0 | | |

Note. The parameter whose symbol is preceded by * is enabled with the following conditions:

* : After setting the parameter, power off and on the servo amplifier or reset the controller.

** : After setting the parameter, cycle the power of the servo amplifier.

15. USING A DIRECT DRIVE MOTOR

15.3.4 Function

(1) Servo control error detection function

| |
|---------------------------------------------------------------------------------------------------------------------------------------------------------|
| POINT |
| <p>● For the servo control error detection function, the position and speed deviation error detections are enabled by default. ([Pr. PL04]: __ _ 3)</p> |

If the servo control gets unstable for some reasons, the direct drive motor may not operate properly. To detect this state and to stop operation, the servo control error detection function is used as a protective function.

The servo control error detection function has three different detection methods: the position deviation, speed deviation, and torque deviation. An error is detected when each method is enabled with [Pr. PL04 Linear servo motor/DD motor function selection 2]. The detection level can be changed with [Pr. PL05], [Pr. PL06], and [Pr. PL07].

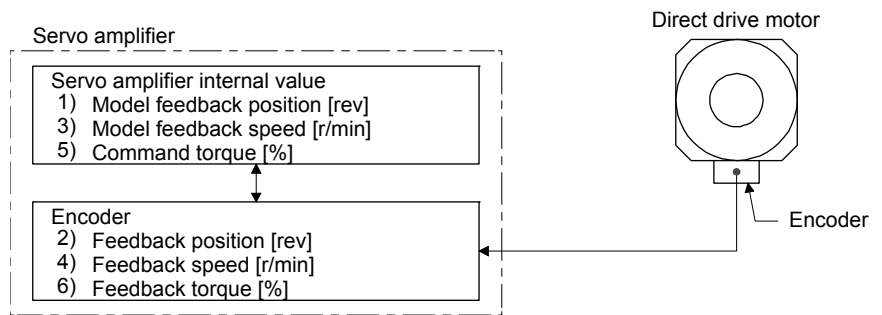
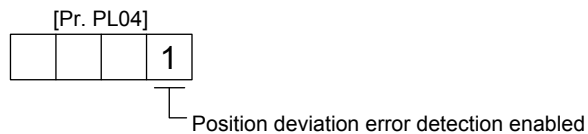

Figure 15.1 Outline of servo control error detection function

(a) Position deviation error detection

Set [Pr. PL04] to "__ _ 1" to enable the position deviation error detection.



When you compare the model feedback position (1)) and the feedback position (2)) in figure 15.1, if the deviation is more than the value of [Pr. PL05 Position deviation error detection level] (1 (0.01 rev) to 1000 (10 rev)), [AL. 42.1 Servo control error by position deviation] will occur and the linear servo motor will stop. The initial value of this detection level is 0.09 rev. Replace the set value as required.

15. USING A DIRECT DRIVE MOTOR

(b) Speed deviation error detection

Set [Pr. PL04] to "___2" to enable the speed deviation error detection.

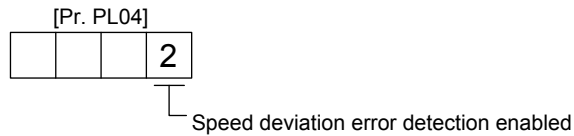

When you compare the model feedback speed (3)) and the feedback speed (4)) in figure 15.1, if the deviation is more than the value of [Pr. PL06 Speed deviation error detection level] (1 r/min to 2000 r/min), [AL. 42.2 Servo control error by speed deviation] will occur and the linear servo motor will stop. The initial value of this detection level is 100 r/min. Replace the set value as required.

(c) Torque deviation error detection level

Set [Pr. PL04] to "___4" to enable the torque deviation error detection.

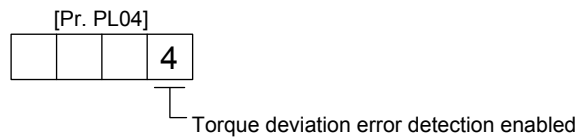

When you compare the command torque (5)) and the feedback torque (6)) in figure 15.1, if the deviation is more than the value of [Pr. PL07 Torque/thrust deviation error detection level] (1% to 1000%), [AL. 42.3 Servo control error by torque/thrust deviation] will occur and the linear servo motor will stop. The initial value of this detection level is 100%. Replace the set value as required.

(d) Detecting multiple deviation errors

When setting [Pr. PL04] as shown below, multiple deviation errors can be detected. For the error detection methods, refer to (1) (a), (b), (c) in this section.

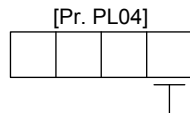

| Setting value | Position deviation error detection | Speed deviation error detection | Torque deviation error detection |
|---------------|------------------------------------|---------------------------------|----------------------------------|
| 1 | ○ | | |
| 2 | | ○ | |
| 3 | ○ | ○ | |
| 4 | | | ○ |
| 5 | ○ | | ○ |
| 6 | | ○ | ○ |
| 7 | ○ | ○ | ○ |

15. USING A DIRECT DRIVE MOTOR

15.4 Characteristics

15.4.1 Overload protection characteristics

An electronic thermal relay is built in the servo amplifier to protect the servo amplifier, the direct drive motor, and direct drive motor power wires from overloads.

[AL. 50 Overload 1] occurs if overload operation performed is above the electronic thermal protection curve shown in fig. 15.2. [AL. 51 Overload 2] occurs if the maximum current is applied continuously for several seconds due to machine collision, etc. Use the equipment on the left-side area of the continuous or broken line in the graph.

For the system where the unbalanced torque occurs, such as a vertical axis system, it is recommended that the unbalanced torque of the machine be kept at 70% or less of the motor's rated torque.

This servo amplifier has solid-state direct drive motor overload protection for each axis. (The direct drive motor overload current (full load current) is set on the basis of 120% rated current of the servo amplifier.)

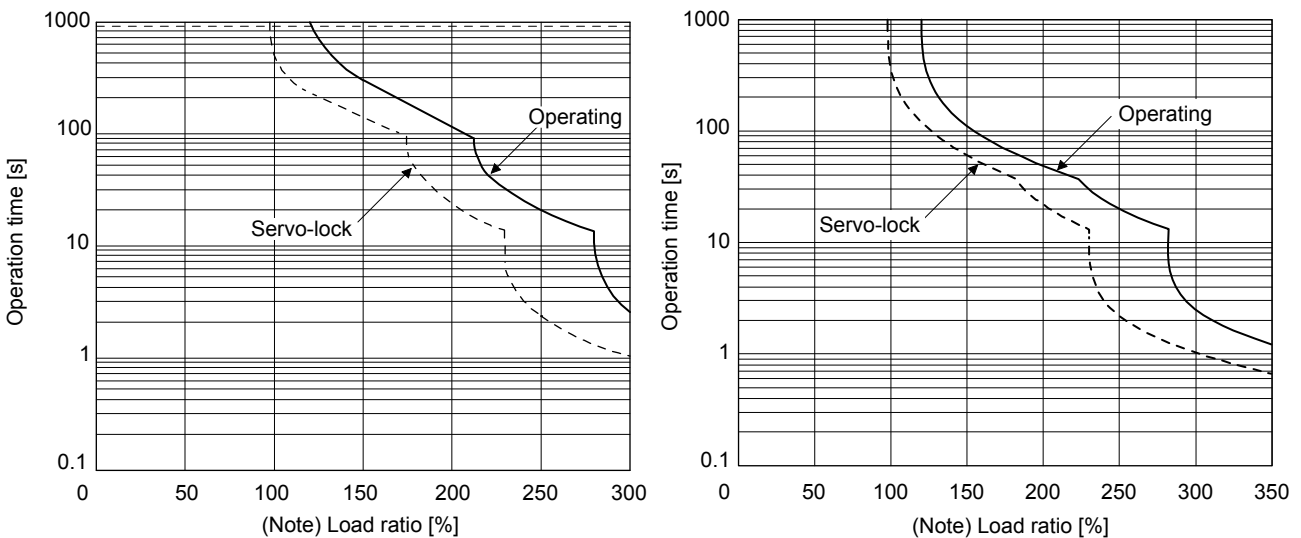

TM-RFM002C20/TM-RFM004C20/TM-RFM006C20
TM-RFM006E20/TM-RFM012E20/TM-RFM018E20
TM-RFM012G20
TM-RFM040J10

TM-RG2M002C30
TM-RU2M002C30
TM-RG2M004E30
TM-RU2M004E30
TM-RG2M009G30
TM-RU2M009G30

Note. If operation that generates torque more than 100% of the rating is performed with an abnormally high frequency in a direct drive motor stop status (servo-lock status) or in a 50 r/min or less low-speed operation status, the servo amplifier may malfunction regardless of the electronic thermal relay protection.

Fig. 15.2 Electronic thermal protection characteristics

15. USING A DIRECT DRIVE MOTOR

15.4.2 Power supply capacity and generated loss

Calculate the generated loss and the power supply capacity of the servo amplifier under rated load from (1) and (2) in this section. The calculated value will vary depending on the number of connected direct drive motors and the capacities of the direct drive motors. For thermal design of an enclosed type cabinet, use the values calculated in consideration for the worst operating conditions. The actual amount of generated heat will be intermediate between values at rated torque and servo-off according to the duty used during operation. When the direct drive motor is run at less than the rated speed, the power supply capacity will be smaller than the calculated value, but the servo amplifier's generated heat will not change.

(1) Calculation method of power supply capacity

Calculate the power supply capacity for one servo amplifier from tables 15.1 and 15.2.

Table 15.1 Power supply capacity for one servo amplifier at rated output

| Servo amplifier | Power supply capacity [kVA] (Note) |
|-----------------|----------------------------------------------------------------------------------|
| MR-J4W2-22B | Total power supply capacity of connected direct drive motors ((A) in table 15.2) |
| MR-J4W2-44B | |
| MR-J4W2-77B | |
| MR-J4W2-1010B | |
| MR-J4W3-222B | |
| MR-J4W3-444B | |

Note. The power supply capacity will vary according to the power supply impedance. This value is applicable when the power factor improving reactor is not used.

Table 15.2 Servo amplifier power supply capacity for one direct drive motor

| Servo motor | Power supply capacity [kVA] (A) (Note) |
|---------------|----------------------------------------|
| TM-RFM002C20 | 0.25 |
| TM-RFM004C20 | 0.38 |
| TM-RFM006C20 | 0.53 |
| TM-RFM006E20 | 0.46 |
| TM-RFM012E20 | 0.81 |
| TM-RFM018E20 | 1.3 |
| TM-RFM012G20 | 0.71 |
| TM-RFM040J10 | 1.2 |
| TM-RG2M002C30 | 0.25 |
| TM-RU2M002C30 | 0.25 |
| TM-RG2M004E30 | 0.5 (0.7) |
| TM-RU2M004E30 | 0.5 (0.7) |
| TM-RG2M009G30 | 0.9 |
| TM-RU2M009G30 | 0.9 |

Note. The value inside () applies when the torque is increased.

Calculate the power supply capacity with equation 10.1 in (1) in section 10.2.

15. USING A DIRECT DRIVE MOTOR

(2) Calculation method of the amount of heat generated by the servo amplifier

Calculate the amount of heat generated by one servo amplifier from tables 15.3 and 15.4.

Table 15.3 Amount of heat generated by one servo amplifier at rated output

| Servo amplifier | Servo amplifier-generated heat [W] (Note) | |
|-----------------|-------------------------------------------|---------------------------------------------------------------------------------------------------------------------------------------------------------------------------------------------|
| | With servo-off (C) | At rated output |
| MR-J4W2-22B | 20 | Sum of the total amount of heat generated by the servo amplifier for each direct drive motor ((B) in table 15.4) and the amount of heat generated by the servo amplifier with servo-off (C) |
| MR-J4W2-44B | 20 | |
| MR-J4W2-77B | 20 | |
| MR-J4W2-1010B | 20 | |
| MR-J4W3-222B | 20 | |
| MR-J4W3-444B | 25 | |

Note. Heat generated during regeneration is not included in the servo amplifier-generated heat. To calculate heat generated by the regenerative option, refer to section 11.2.

Table 15.4 Amount of heat generated by one servo amplifier for one direct drive motor

| Servo motor | Servo amplifier-generated heat [W] (B) (Note) |
|---------------|-----------------------------------------------|
| TM-RFM002C20 | 25 |
| TM-RFM004C20 | 35 |
| TM-RFM006C20 | 40 |
| TM-RFM006E20 | 40 |
| TM-RFM012E20 | 50 |
| TM-RFM018E20 | 50 |
| TM-RFM012G20 | 50 |
| TM-RFM040J10 | 50 |
| TM-RG2M002C30 | 25 |
| TM-RU2M002C30 | 25 |
| TM-RG2M004E30 | 25 (35) |
| TM-RU2M004E30 | 25 (35) |
| TM-RG2M009G30 | 35 |
| TM-RU2M009G30 | 35 |

Note. The value inside () applies when the torque is increased.

Calculate the amount of heat generated by the servo amplifier with equation 10.2 in (2) in section 10.2.

15. USING A DIRECT DRIVE MOTOR

15.4.3 Dynamic brake characteristics



CAUTION

● The coasting distance is a theoretically calculated value which ignores the running load such as friction. The calculated value will be longer than the actual distance. If an enough braking distance is not provided, a moving part may crash into the stroke end, which is very dangerous. Install the anti-crash mechanism such as an air brake or an electric/mechanical stopper such as a shock absorber to reduce the shock of moving parts.

| POINT |
|-------------------------------------------------------------------------------------------------------------------------------------------------------------------------------------------------------------------------------------------|
| ● Do not use dynamic brake to stop in a normal operation as it is the function to stop in emergency. |
| ● For a machine operating at the recommended load to motor inertia ratio or less, the estimated number of usage times of the dynamic brake is 1000 times while the machine decelerates from the rated speed to a stop once in 10 minutes. |
| ● Be sure to enable EM1 (Forced stop 1) after the direct drive motor stops when using EM1 (Forced stop 1) frequently in other than emergency. |

(1) Dynamic brake operation

(a) Calculation of coasting distance

Fig. 15.3 shows the pattern in which the servo motor comes to a stop when the dynamic brake is operated. Use equation 15.1 to calculate an approximate coasting distance to a stop. The dynamic brake time constant τ varies with the direct drive motor and machine operation speeds. (Refer to (1) (b) in this section.)

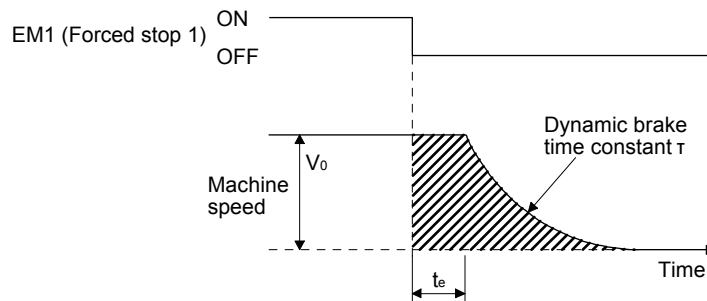

Fig. 15.3 Dynamic brake operation diagram

$$L_{\max} = \frac{V_0}{60} \cdot \left\{ t_e + \tau \left(1 + \frac{J_L}{J_M} \right) \right\} \dots \dots \dots (15.1)$$

- L_{\max} : Maximum coasting distance [mm]
 - V_0 : Machine's fast feed speed [mm/min]
 - J_M : Moment of inertia of direct drive motor [$\times 10^{-4}$ kg·m²]
 - J_L : Load moment of inertia converted into equivalent value on direct drive motor rotor .. [$\times 10^{-4}$ kg·m²]
 - τ : Dynamic brake time constant [s]
 - t_e : Delay time of control section [s]
- There is internal relay delay time of about 10 ms

15. USING A DIRECT DRIVE MOTOR

(b) Dynamic brake time constant

The following shows necessary dynamic brake time constant τ for the equation (15.1).

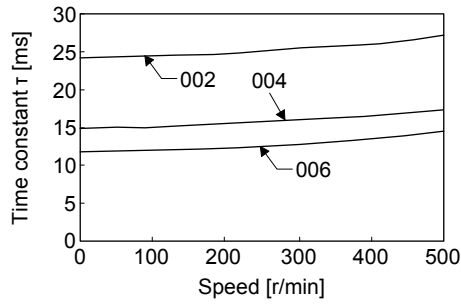

TM-RFM_C20

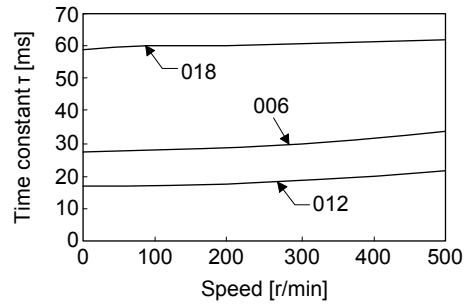

TM-RFM_E20

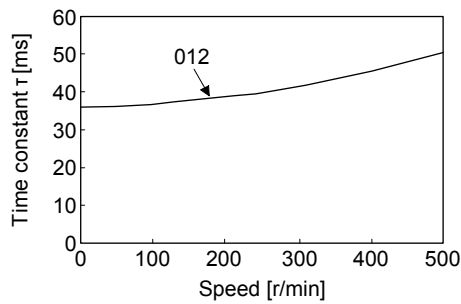

TM-RFM_G20

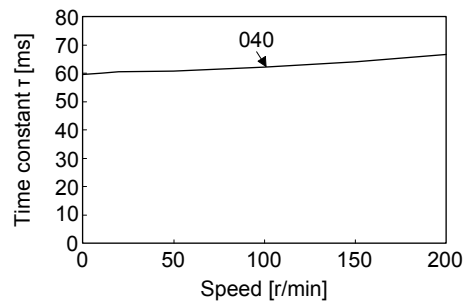

TM-RFM_J10

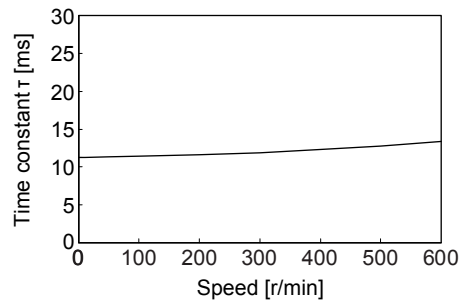

TM-RG2M002C30
TM-RU2M002C30

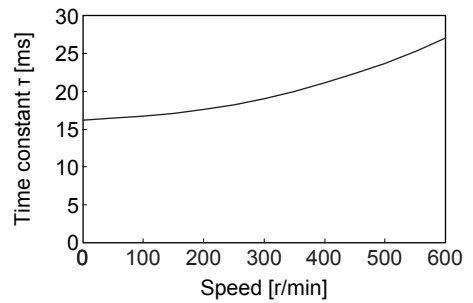

TM-RG2M004E30
TM-RU2M004E30

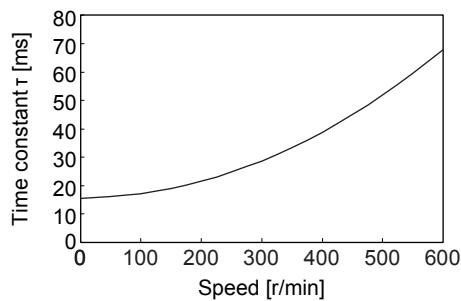

TM-RG2M009G30
TM-RU2M009G30

15. USING A DIRECT DRIVE MOTOR

(2) Permissible load to motor inertia ratio when the dynamic brake is used

Use the dynamic brake under the load to motor inertia ratio indicated in the following table. If the load inertia moment is higher than this value, the dynamic brake may burn. If there is a possibility that the load inertia moment may exceed the value, contact your local sales office.

The values of the permissible load to motor inertia ratio in the table are the values at the maximum rotation speed of the direct drive motor.

The value in the parenthesis shows the value at the rated speed of the direct drive motor.

| Direct drive motor | Permissible load to motor inertia ratio [multiplier] |
|--------------------|---------------------------------------------------------|
| TM-RFM_C20 | 100 (300) |
| TM-RFM_E20 | |
| TM-RG2M002C30 | |
| TM-RU2M002C30 | |
| TM-RFM_G20 | 50 (300) |
| TM-RFM_J10 | 50 (200) |
| TM-RG2M_E30 | 20 (80) |
| TM-RG2M_G30 | |
| TM-RU2M_E30 | |
| TM-RU2M_G30 | |

16. FULLY CLOSED LOOP SYSTEM

The following table shows the functions of each control mode.

| Control | Description | |
|---------------------------|--------------|--------------------------------------------------------------------------------------------------------------------------------------------------------------------------------------------------------------------------------------------------------|
| Semi closed loop control | Feature | Position is controlled according to the servo motor-side data. |
| | Advantage | Since this control is insusceptible to machine influence (such as machine resonance), the gains of the servo amplifier can be raised and the settling time shortened. |
| | Disadvantage | If the servo motor side is at a stop, the side may be vibrating or the load-side accuracy not obtained. |
| Dual feedback control | Feature | Position is controlled according to the servo motor-side data and load-side data. |
| | Advantage | Control is performed according to the servo motor-side data during operation, and according to the load side-data at a stop in sequence to raise the gains during operation and shorten the settling time. A stop is made with the load-side accuracy. |
| Fully closed loop control | Feature | Position is controlled according to the load-side data. |
| | Advantage | The load-side accuracy is obtained not only at a stop but also during operation. |
| | Disadvantage | Since this control is susceptible to machine resonance or other influences, the gains of the servo amplifier may not rise. |

16. FULLY CLOSED LOOP SYSTEM

16.1.2 Selecting procedure of control mode

(1) Control mode configuration

In this servo, a semi closed loop system or fully closed loop system can be selected as a control system. In addition, on the fully closed loop system, the semi closed loop control, fully closed loop control and dual feedback control can be selected by the [Pr. PE08] settings.

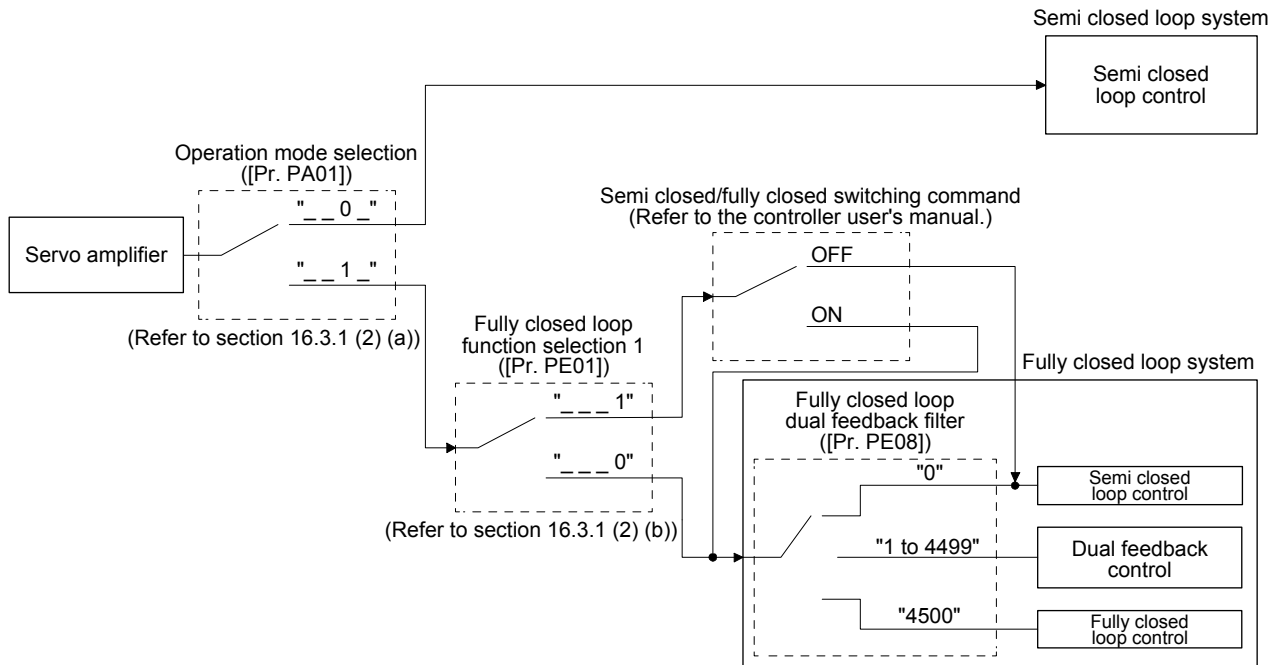

(2) Dual feedback filter equivalent block diagram

A dual feedback filter equivalent block diagram on the dual feedback control is shown below.

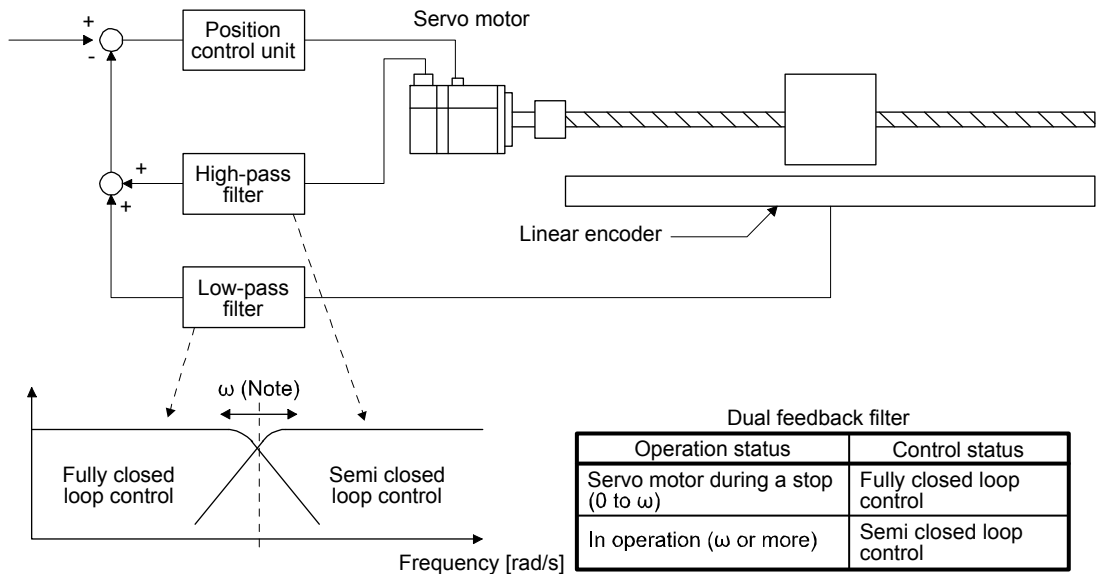

Note. Set " ω " (a dual feedback filter band) with [Pr. PE08].

16. FULLY CLOSED LOOP SYSTEM

16.1.3 System configuration

(1) For a linear encoder

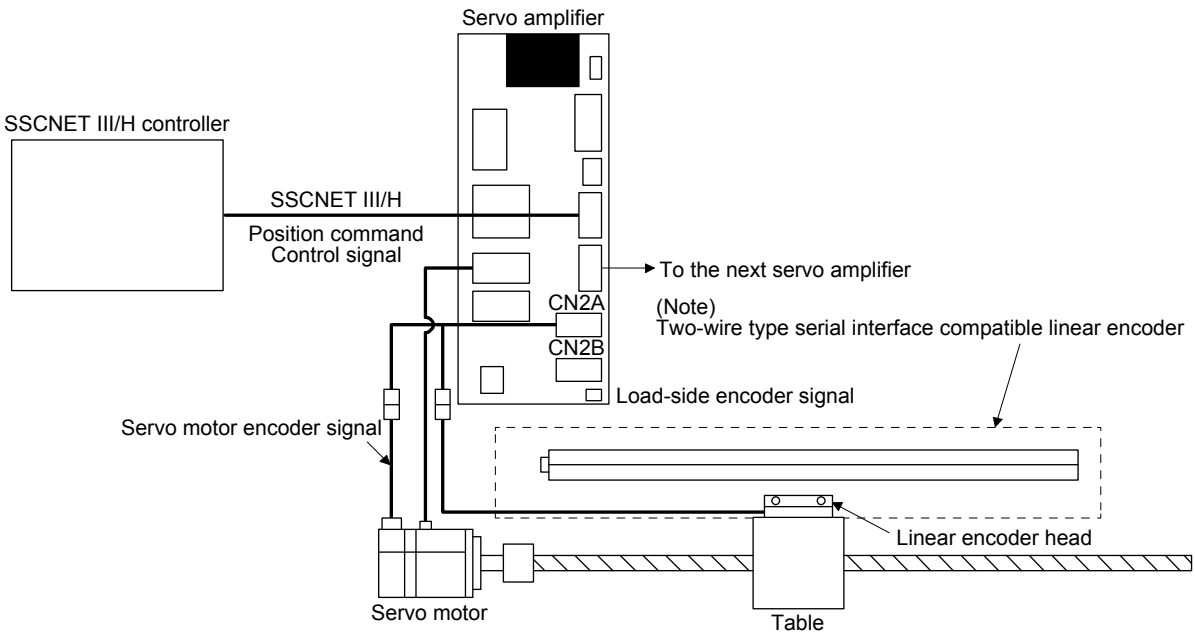

Note. Applicable for the absolute position detection system when an absolute position linear encoder is used.
In that case, a battery is not required.

(2) For a rotary encoder

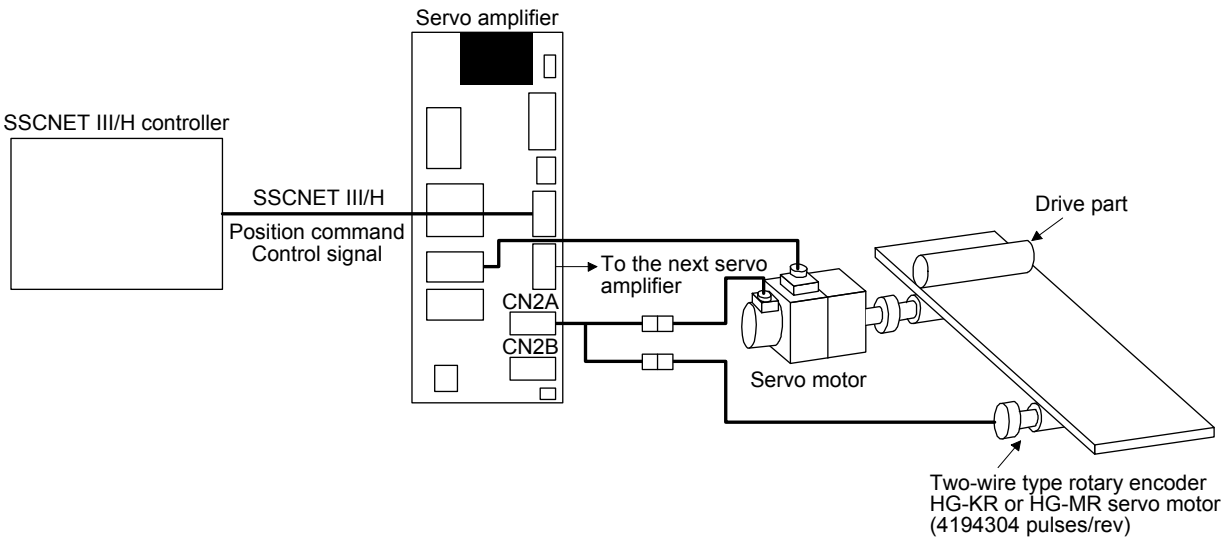

16. FULLY CLOSED LOOP SYSTEM

16.2 Load-side encoder

| POINT |
|----------------------------------------------------------------------------------------------------------------------------------------------------------------------------------------------------------------------------------------------------------------------------------------------------|
| <ul style="list-style-type: none"> ● Always use the load-side encoder cable introduced in this section. Using other products may cause a malfunction. ● For details of the load-side encoder specifications, performance and assurance, contact each encoder manufacturer. |

16.2.1 Linear encoder

Refer to "Linear Encoder Instruction Manual" for usable linear encoders.

16.2.2 Rotary encoder

When a rotary encoder is used for the load-side encoder, use HG-KR or HG-MR servo motor as an encoder. Use a two-wire type encoder cable. Do not use MR-EKCBL30M-L, MR-EKCBL30M-H, MR-EKCBL40M-H, or MR-EKCBL50M-H as they are four-wire type.

16.2.3 Configuration diagram of encoder cable

Configuration diagram for servo amplifier and load-side encoder is shown below. Cables used vary, depending on the load-side encoder.

(1) Linear encoder

Refer to Linear Encoder Instruction Manual for encoder cables for linear encoder.

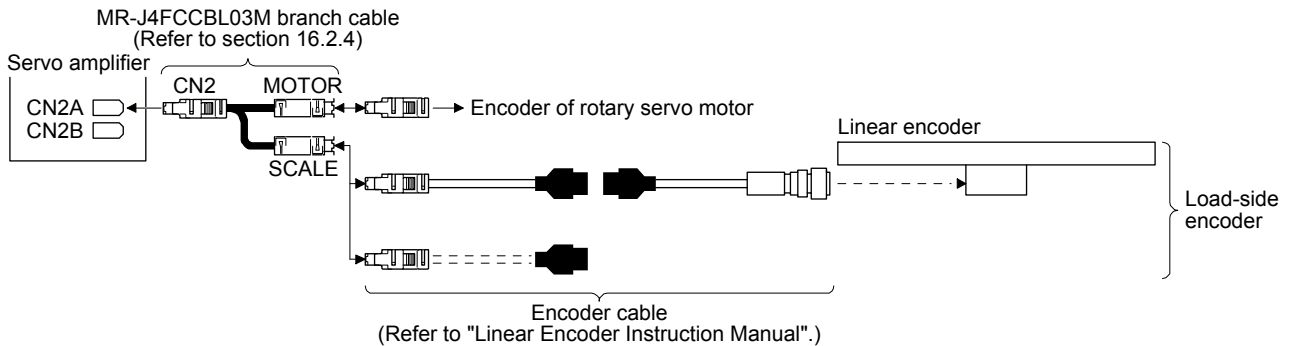

(2) Rotary encoder

Refer to "Servo Motor Instruction Manual (Vol. 3)" for encoder cables for rotary encoders.

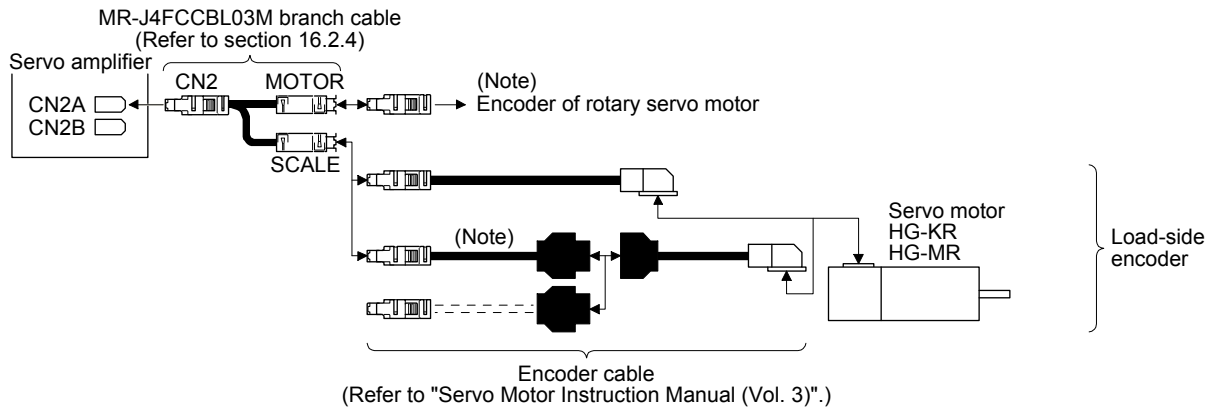

Note. Use a two-wire type encoder cable. A four-wire type linear encoder cable cannot be used.

16. FULLY CLOSED LOOP SYSTEM

16.2.4 MR-J4FCCBL03M branch cable

Use MR-J4FCCBL03M branch cable to connect the rotary encoder and the load-side encoder to CN2A or CN2B connector.

When fabricating the branch cable using MR-J3THMCN2 connector set, refer to "Linear Encoder Instruction Manual".

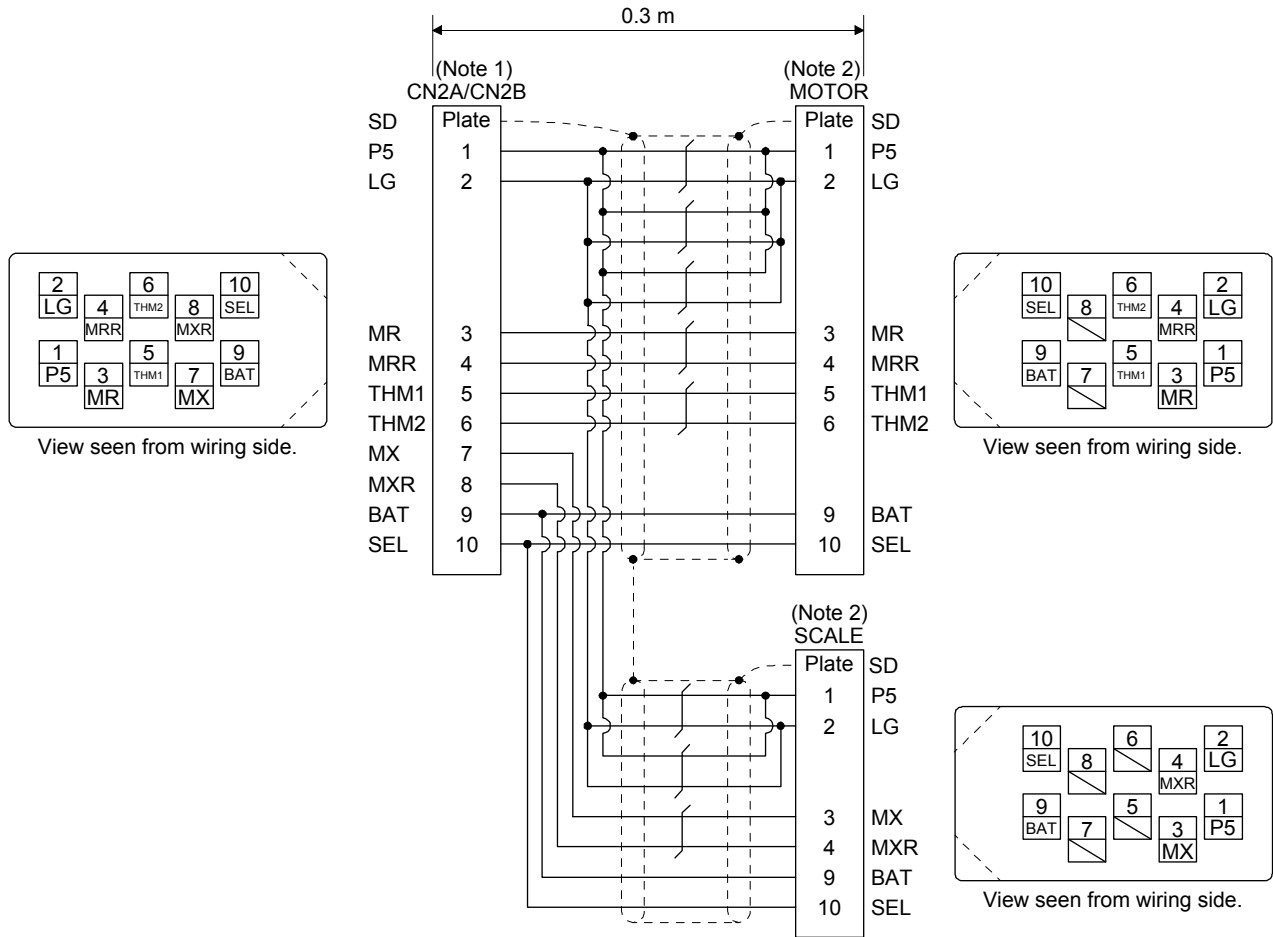

- Note 1. Receptacle: 36210-0100PL, shell kit: 36310-3200-008 (3M)
 Note 2. Plug: 36110-3000FD, shell kit: 36310-F200-008 (3M)

16. FULLY CLOSED LOOP SYSTEM

16.3 Operation and functions

16.3.1 Startup

(1) Startup procedure

Start up the fully closed loop system in the following procedure.

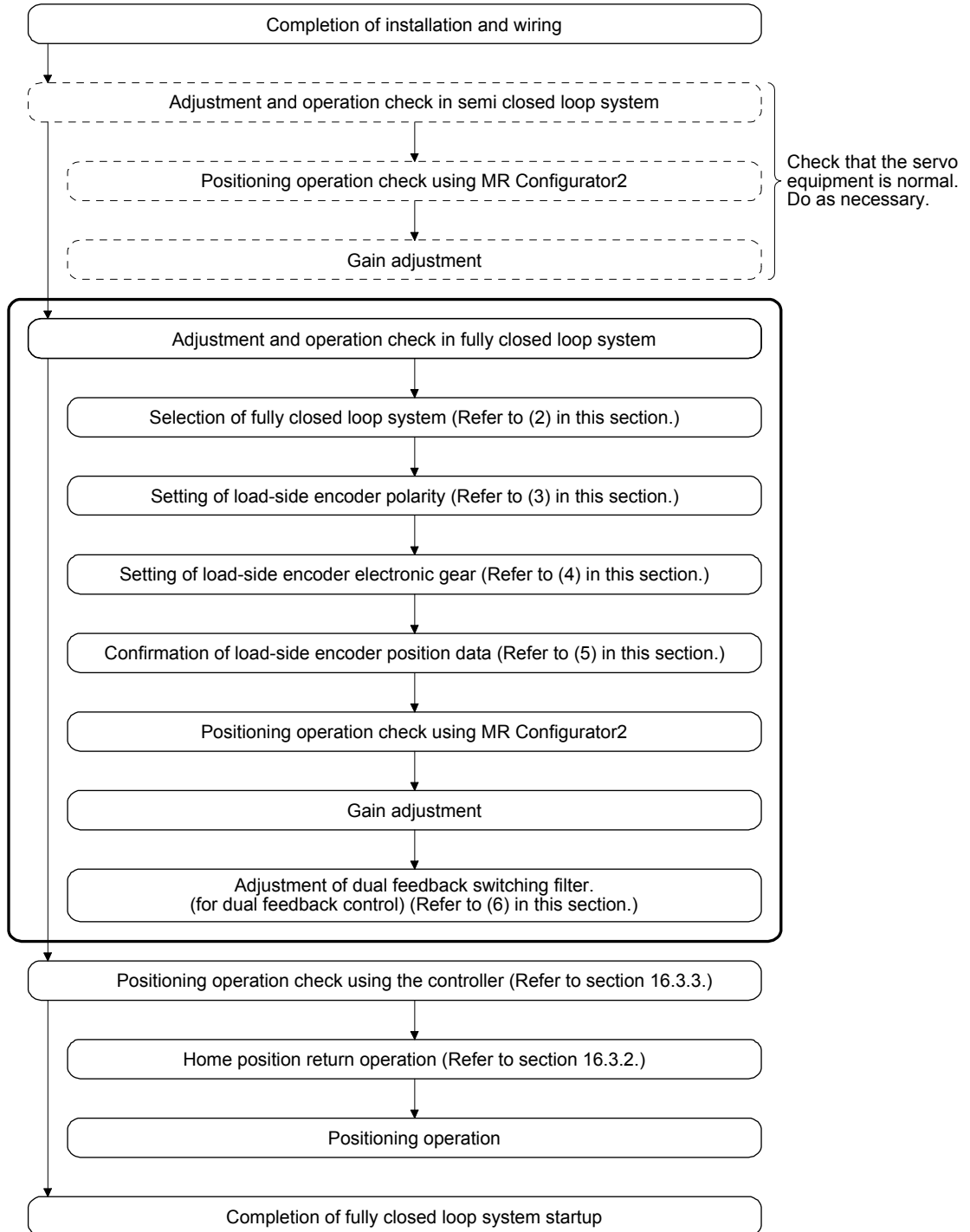

16. FULLY CLOSED LOOP SYSTEM

(2) Selection of fully closed loop system

By setting [Pr. PA01], [Pr. PE01] and the control command of controller, the control method can be selected as shown in the following table.

| [Pr. PA01] | [Pr. PE01] | Semi closed loop control/ fully closed loop control switching signal | Command unit | Control System | Absolute position detection system |
|---------------------------------------------------------------------------------|------------|----------------------------------------------------------------------------|-----------------------------|---------------------------------------------------------|---------------------------------------|
| "__0_" Semi closed loop system (standard control mode) | "/" | "/" | Servo motor encoder unit | Semi closed loop control | ○ |
| "__1_" Fully closed loop system (fully closed loop control mode) | | | Load-side encoder unit | Dual feedback control (fully closed loop control) | ○ (Note) |
| | "___0" | Off | | Semi closed loop control | × |
| | "___1" | On | | Dual feedback control (fully closed loop control) | × |

Note. Applicable when the load-side encoder is set as the absolute position encoder.

(a) Operation mode selection

Select a operation mode.

| [Pr. PA01] |
|------------|
| 1 0 0 0 |

Operation mode selection

| Set value | Operation mode | Control unit |
|-----------|--------------------------------------------------------------|--------------------------------------|
| 0 | Semi closed loop system (Standard control mode) | Servo motor-side resolution unit |
| 1 | Fully closed loop system (Fully closed loop control mode) | Load-side encoder resolution unit |

(b) Semi closed loop control/fully closed loop control selection

Select the semi closed loop control/fully closed loop control.

| [Pr. PE01] |
|------------|
| 0 0 0 0 |

Fully closed loop control selection

0: Always enabled

1: Switching using the control command of controller
(switching between semi closed/fully closed)

| Selection using the control command of controller | Control method |
|------------------------------------------------------|---------------------------|
| OFF | Semi closed loop control |
| ON | Fully closed loop control |

When the operation mode selection in [Pr. PA01] is set to "__1_"
(fully closed loop system), this setting is enabled.

16. FULLY CLOSED LOOP SYSTEM

(3) Setting of load-side encoder polarity



CAUTION

- Do not set an incorrect direction to "Encoder pulse count polarity selection" in [Pr. PC27]. An abnormal operation and a machine collision may occur if an incorrect direction is set, which cause a fault and parts damaged.

POINT

- "Encoder pulse count polarity selection" in [Pr. PC27] is not related to [Pr. PA14 Rotation direction selection]. Make sure to set the parameter according to the relationships between servo motor and linear encoder/rotary encoder.
- Do not set an incorrect direction to "Encoder pulse count polarity selection" in [Pr. PC27]. Doing so may cause [AL. 42 Fully closed loop control error] during the positioning operation.

(a) Parameter setting method

Set the load-side encoder polarity to be connected to CN2A or CN2B connector in order to match the CCW direction of servo motor and the increasing direction of load-side encoder feedback.

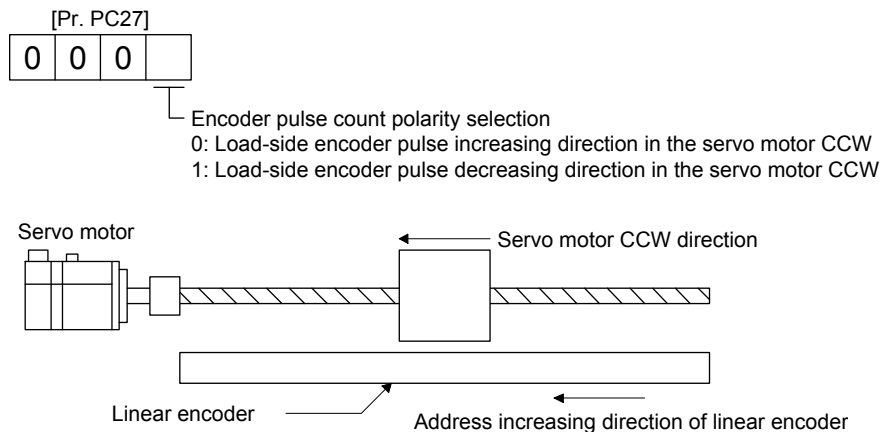

(b) How to confirm the load-side encoder feedback direction

For the way of confirming the load-side encoder feedback direction, refer to (5) in this section.

16. FULLY CLOSED LOOP SYSTEM

(4) Setting of feedback pulse electronic gear

| POINT |
|-----------------------------------------------------------------------------------------------------------------------------------------------------------------------------------------------------------------------------------------------------------------------------------------------------------------------|
| <p>● If an incorrect value is set in the feedback pulse electronic gear ([Pr. PE04], [Pr. PE05], [Pr. PE34], and [Pr. PE35]), [AL. 37 Parameter error] and an abnormal operation may occur. Also, it may cause [AL. 42.1 Fully closed loop control error by position deviation] during the positioning operation.</p> |

Set the numerator ([Pr. PE04] and [Pr. PE34]) and denominator ([Pr. PE05] and [Pr. PE35]) of the electronic gear to the servo motor-side encoder pulse. Set the electronic gear so that the number of servo motor encoder pulses per servo motor revolution is converted to the number of load-side encoder pulses. The relational expression is shown below.

$$\frac{[\text{Pr. PE04}] \times [\text{Pr. PE34}]}{[\text{Pr. PE05}] \times [\text{Pr. PE35}]} = \frac{\text{Number of motor encoder pulses per servo motor revolution}}{\text{Number of load side encoder pulses per servo motor revolution}}$$

Select the load-side encoder so that the number of load-side encoder pulses per servo motor revolution is within the following range.

$$4096 (2^{12}) \leq \text{Number of load-side encoder pulses per servo motor revolution} \leq 67108864 (2^{26})$$

(a) When the servo motor is directly coupled with a ball screw and the linear encoder resolution is 0.05 μm

Conditions

Servo motor resolution: 4194304 pulses/rev

Servo motor reduction ratio: 1/11

Ball screw lead: 20 mm

Linear encoder resolution: 0.05 μm

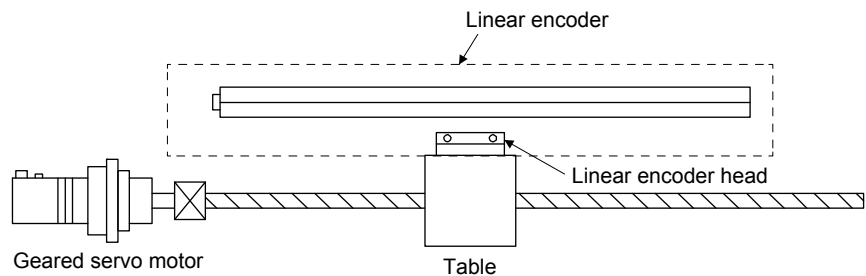

Calculate the number of linear encoder pulses per ball screw revolution.

Number of linear encoder pulses per ball screw revolution
 = Ball screw lead/linear encoder resolution
 = 20 mm/0.05 μm = 400000 pulses

$$\frac{[\text{Pr. PE04}] \times [\text{Pr. PE34}]}{[\text{Pr. PE05}] \times [\text{Pr. PE35}]} = \frac{400000}{4194304} \times \frac{1}{11} = \frac{3125}{32768} \times \frac{1}{11}$$

16. FULLY CLOSED LOOP SYSTEM

(b) Setting example when using the rotary encoder for the load-side encoder of roll feeder

Conditions

Servo motor resolution: 4194304 pulses/rev

Pulley diameter on the servo motor side: 30 mm

Pulley diameter on the rotary encoder side: 20 mm

Rotary encoder resolution: 4194304 pulse/rev

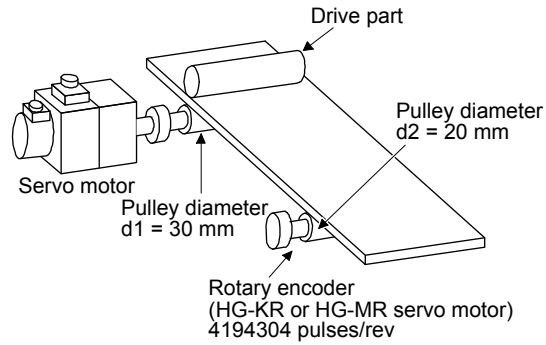

When the pulley diameters or reduction ratios differ, consider that in calculation.

$$\frac{[\text{Pr. PE04}] \times [\text{Pr. PE34}]}{[\text{Pr. PE05}] \times [\text{Pr. PE35}]} = \frac{4194304 \times 30}{4194304 \times 20} = \frac{1}{1} \times \frac{3}{2}$$

16. FULLY CLOSED LOOP SYSTEM

(5) Confirmation of load-side encoder position data

Check the load-side encoder mounting and parameter settings for any problems.

| POINT |
|--------------------------------------------------------------------------------------------------------------------------------------------------------------------------------------------------|
| <ul style="list-style-type: none"> ● Depending on the check items, MR Configurator2 may be used. Refer to section 16.3.6 for the data displayed on the MR Configurator2. |

When checking the following items, the fully closed loop control mode must be set. For the setting of control mode, refer to (2) in this section.

| No. | Check item | Confirmation method and description |
|-----|----------------------------------------------------------------------------------------------|-----------------------------------------------------------------------------------------------------------------------------------------------------------------------------------------------------------------------------------------------------------------------------------------------------------------------------------------------------------------------------------------------------------------------------------------------------------------------------------------------------------------------------------------------------------------------------------------------------------------------------------------------------------------------------------|
| 1 | Read of load-side encoder position data | <p>With the load-side encoder in a normal state (mounting, connection, etc.), the load-side cumulative feedback pulses value is counted normally when the load-side encoder is moved.</p> <p>When it is not counted normally, the following factors can be considered.</p> <ol style="list-style-type: none"> 1. An alarm occurred. 2. The installation of the load-side encoder was not correct. 3. The encoder cable was not wired correctly. |
| 2 | Read of load-side encoder home position (reference mark, Z-phase) | <p>With the home position (reference mark, or Z-phase) of the load-side encoder in a normal condition (mounting, connection, etc.), the value of load-side encoder information 1 is cleared to 0 when the home position (reference mark, or Z-phase) is passed through by moving the load-side encoder.</p> <p>When it is not cleared, the following factors can be considered.</p> <ol style="list-style-type: none"> 1. The installation of the load-side encoder was not correct. 2. The encoder cable was not wired correctly. |
| 3 | Confirmation of load-side encoder feedback direction (Setting of load-side encoder polarity) | <p>Confirm that the directions of the cumulative feedback pulses of servo motor encoder (after gear) and the load-side cumulative feedback pulses are matched by moving the device (load-side encoder) manually in the servo-off status. If mismatched, reverse the polarity.</p> |
| 4 | Setting of load-side encoder electronic gear | <p>When the servo motor and load-side encoder operate synchronously, the servo motor-side cumulative feedback pulses (after gear) and load-side cumulative feedback pulses are matched and increased.</p> <p>If mismatched, review the setting of fully closed loop control feedback electronic gear ([Pr. PE04], [Pr. PE05], [Pr. PE34], and [Pr. PE35]) with the following method.</p> <ol style="list-style-type: none"> 1) Check the servo motor-side cumulative feedback pulses (before gear). 2) Check the load-side cumulative feedback pulses. 3) Check that the ratio of above 1) and 2) has been that of the feedback electronic gear. |

16. FULLY CLOSED LOOP SYSTEM

(6) Setting of fully closed loop dual feedback filter

With the initial value (setting = 10) set in [Pr. PE08 Fully closed loop dual feedback filter the dual feedback filter], make gain adjustment by auto tuning, etc. as in semi closed loop control. While observing the servo operation waveform with the graph function, etc. of MR Configurator2, adjust the dual feedback filter.

The dual feedback filter operates as described below depending on the setting.

| [Pr. PE08] setting | Control mode | Vibration | Settling time |
|--------------------|-------------------|--------------------------------------------------|-------------------------------|
| 0 | Semi closed loop | | |
| 1 to 4499 | Dual feedback | Not frequently occurs to Frequently occurs | Long time to Short time |
| 4500 | Fully closed loop | | |

Increasing the dual feedback filter setting shortens the settling time, but increases servo motor vibration since the motor is more likely to be influenced by the load-side encoder vibration. The maximum setting of the dual feedback filter should be less than half of the PG2 setting.

Reduction of settling time: Increase the dual feedback filter setting.

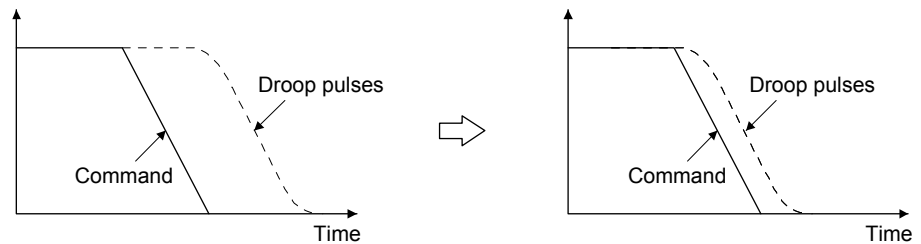

Suppression of vibration: Decrease the dual feedback filter setting.

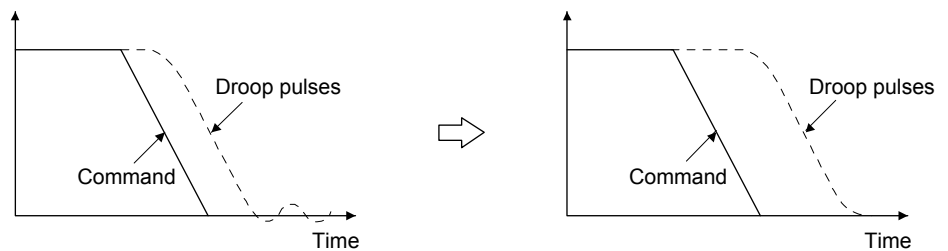

16. FULLY CLOSED LOOP SYSTEM

16.3.2 Home position return

(1) General instruction

Home position return is all performed according to the load-side encoder feedback data, independently of the load-side encoder type. It is irrelevant to the Z-phase position of the servo motor encoder. In the case of a home position return using a dog signal, the home position (reference mark) must be passed through when an incremental type linear encoder is used, or the Z-phase be passed through when a rotary encoder is used, during a period from a home position return start until the dog signal turns off.

(2) Load-side encoder types and home position return methods

(a) About proximity dog type home position return using absolute type linear encoder

When an absolute type linear encoder is used, the home position reference position is the position per servo motor revolution to the linear encoder home position (absolute position data = 0).

In the case of a proximity dog type home position return, the nearest position after proximity dog off is the home position.

The linear encoder home position may be set in any position.

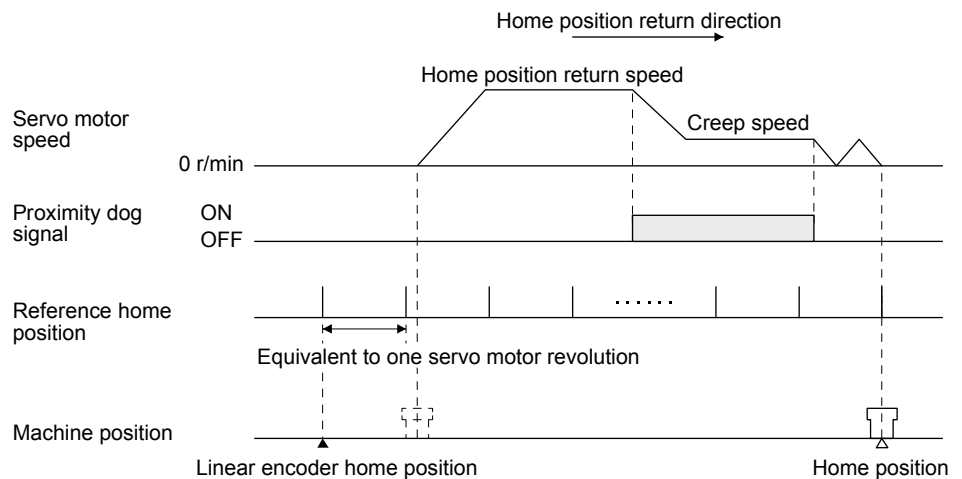

16. FULLY CLOSED LOOP SYSTEM

(b) About proximity dog type home position return using incremental linear encoder

1) When the linear encoder home position (reference mark) exists in the home position return direction

When an incremental linear encoder is used, the home position is the position per servo motor revolution to the linear encoder home position (reference mark) passed through first after a home position return start.

In the case of a proximity dog type home position return, the nearest position after proximity dog off is the home position.

Set one linear encoder home position in the full stroke, and set it in the position that can always be passed through after a home position return start.

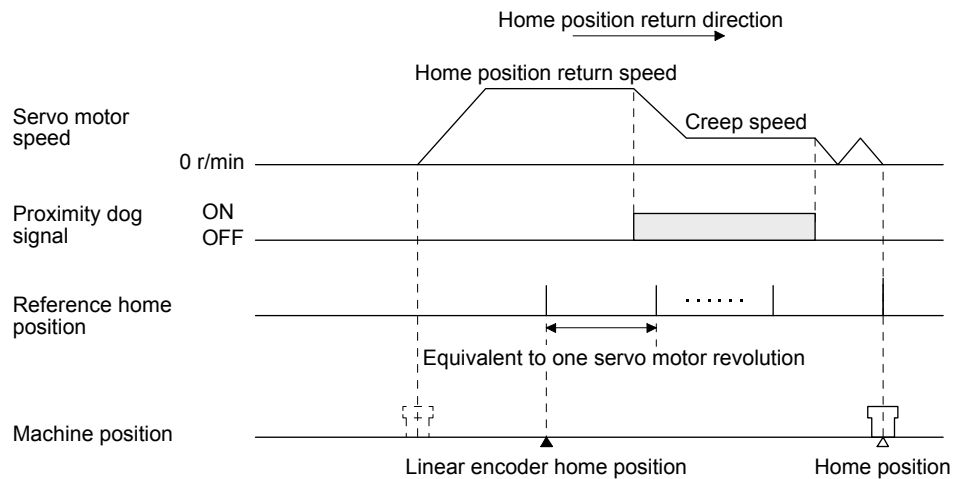

2) When the linear encoder home position does not exist in the home position return direction

| POINT |
|---------------------------------------------------------------------------------------------------------------------------------------------------------------------------------------------------------------------------------------------------------------------------------------------------------------------------------------------------------------------------------------------------------------------------------------------------------------------------|
| <ul style="list-style-type: none"> ● To execute a home position return securely, start a home position return after moving the axis to the opposite stroke end by jog operation, etc. of the controller. ● A home position return cannot be made if the incremental linear encoder does not have a linear encoder home position (reference mark). Always provide a linear encoder home position (reference mark). (one place in the fully stroke) |

16. FULLY CLOSED LOOP SYSTEM

If the home position return is performed from the position where the linear encoder home position (reference mark) does not exist, a home position return error occurs on the controller side. The error contents differ according to the controller type. When starting a home position return at the position where the linear encoder home position (reference mark) does not exist in the home position return direction, move the axis up to the stroke end on the side opposite to the home position return direction by JOG operation, etc. of the controller once, then make a home position return.

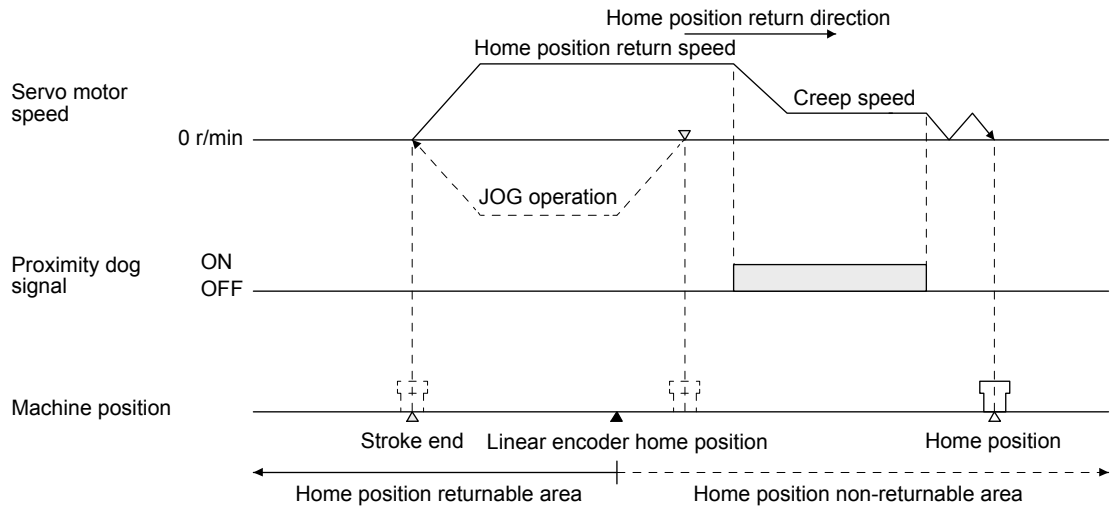

- (c) About dog type home position return when using the rotary encoder of a serial communication servo motor

The home position for when using the rotary encoder of a serial communication servo motor for the load-side encoder is at the load-side Z-phase position.

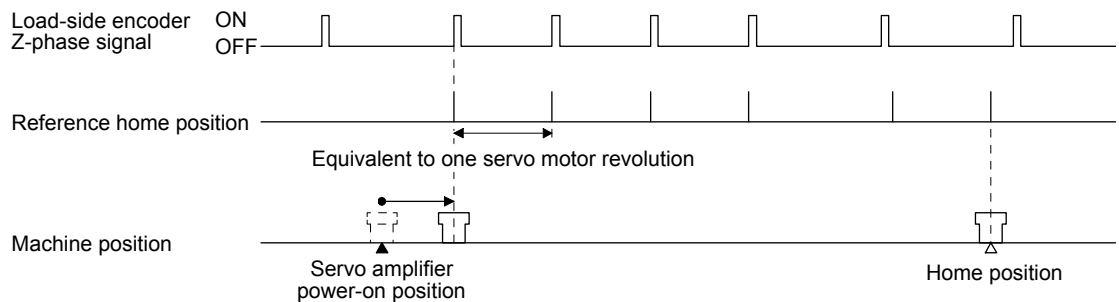

- (b) About data setting type (Common to all load-side encoders)

In the data setting type home position return method, pass through a home position (reference mark) and the Z-phase signal of the rotary encoder, and then make a home position return.

When the machine has no distance of one servo motor encoder revolution until the Z-phase of the rotary encoder is passed through, a home position return can be made by changing the home position setting condition selection in [Pr. PC17] if the home position is not yet passed through.

16. FULLY CLOSED LOOP SYSTEM

16.3.3 Operation from controller

The fully closed loop control compatible servo amplifier can be used with any of the following controllers.

| Category | Model | Remark |
|----------------------|-------------------------|---------------------------------------------------------------|
| Motion controller | R_MTCPU/Q17_DSCPU | Speed control (II) instructions (VVF and VVR) cannot be used. |
| Simple motion module | RD77MS_/QD77MS_/LD77MS_ | |

An absolute type linear encoder is necessary to configure an absolute position detection system under fully closed loop control using a linear encoder. In this case, the encoder battery need not be installed to the servo amplifier. When an rotary encoder is used, an absolute position detection system can be configured by installing the encoder battery to the servo amplifier. In this case, the battery life will be shorter because the power consumption is increased as the power is supplied to the two encoders of motor side and load side.

(1) Operation from controller

Positioning operation from the controller is basically performed like the semi closed loop control.

(2) Servo system controller setting

When using fully closed loop system, make the following setting.

[Pr. PA01], [Pr. PC17], [Pr. PE01], [Pr. PE03] to [Pr. PE05], [Pr. PE34] and [Pr. PE35] are written to the servo amplifier and then are enabled using any of the methods indicated by ○ in Parameter enabled conditions. [Pr. PE06] to [Pr. PE08] are enabled at setting regardless of the valid conditions.

| Setting item | | Parameter enabled conditions | | Settings | |
|-----------------------------------------------------|-------------------------------------------------------------------------------------------------|-----------------------------------------------------------------|---------------------|-------------------------------------|----------------------------------------------|
| | | Controller reset | Power supply Off→on | Motion controller R_MTCPU/Q17_DSCPU | Simple motion module RD77MS_/QD77MS_/LD77MS_ |
| Command resolution | | | | | Load-side encoder resolution unit |
| Servo parameter | MR-J4-B fully closed loop servo amplifier setting | | | | MR-J4-B fully closed loop control |
| | Motor setting | | | | Automatic setting |
| | Home position setting condition selection ([Pr. PC17]) | ○ | ○ | | Set the items as required. |
| | Fully closed loop selection ([Pr. PA01] and [Pr. PE01]) | × | ○ | | |
| | Fully closed loop selection 2 ([Pr. PE03]) | ○ | ○ | | |
| | Fully closed loop control error detection speed deviation error detection level ([Pr. PE06]) | Enabled at setting regardless of the enabled conditions | | | |
| | Fully closed loop control error detection position deviation error detection level ([Pr. PE07]) | Enabled at setting regardless of the enabled conditions | | | |
| | Fully closed loop electronic gear numerator ([Pr. PE04] and [Pr. PE34]) | × | ○ | | |
| | Fully closed loop electronic gear denominator ([Pr. PE05] and [Pr. PE35]) | × | ○ | | |
| Fully closed loop dual feedback filter ([Pr. PE08]) | Enabled at setting regardless of the enabled conditions | | | | |
| Positioning control parameter | Unit setting | mm/inch/degree/pulse | | | |
| | Number of pulses per revolution (AP) Travel distance per revolution (AL) | For the setting methods, refer to (2) (a), (b) in this section. | | | |

16. FULLY CLOSED LOOP SYSTEM

(a) When using a linear encoder (unit setting: mm)

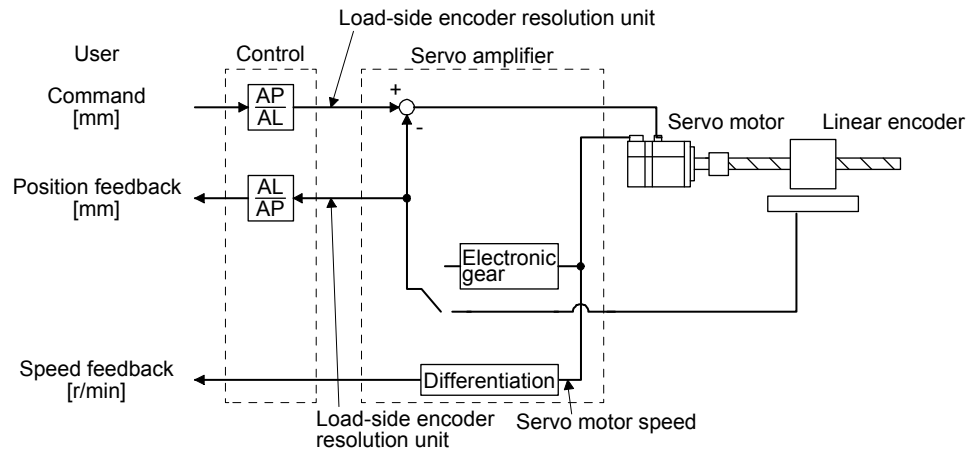

Calculate the number of pulses (AP) and travel distance (AL) of the linear encoder per ball screw revolution in the following conditions.

Ball screw lead: 20 mm

Linear encoder resolution: 0.05 μm

Number of linear encoder pulses (AP) per ball screw revolution

$$= \text{Ball screw lead/linear encoder resolution} = 20 \text{ mm}/0.05 \mu\text{m} = 400000 \text{ pulses}$$

$$\frac{\text{Number of pulses per revolution [pulse] (AP)}}{\text{Travel distance per revolution } [\mu\text{m}] \text{ (AL)}} = \frac{400000 \text{ pulses}}{20 \text{ mm}} = \frac{400000}{20000}$$

(b) When using a rotary encoder (unit setting: degree)

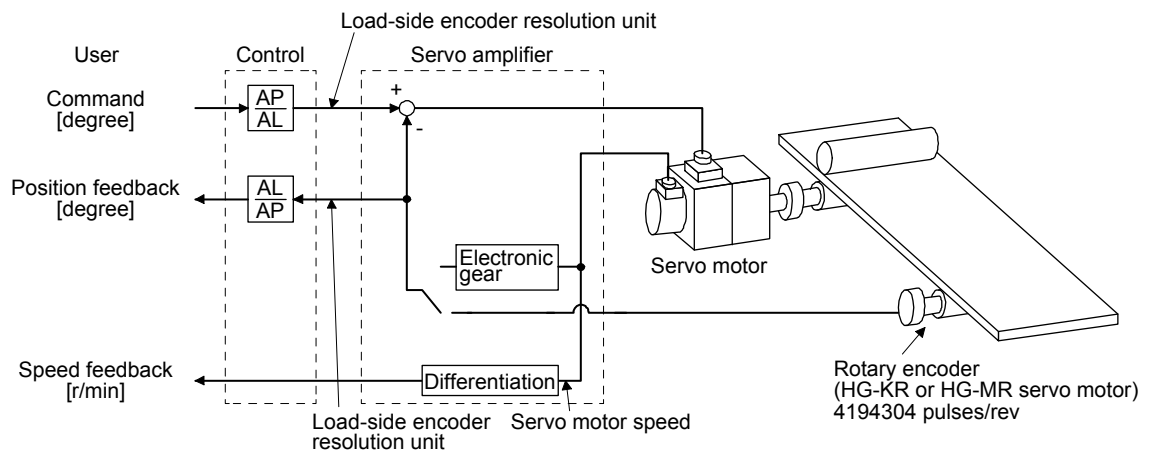

Calculate the number of pulses (AP) and travel distance (AL) of the rotary encoder per servo motor revolution in the following conditions.

Resolution of rotary encoder = Load-side resolution: 4194304 pulses/rev

$$\frac{\text{Number of pulses per revolution [pulse] (AP)}}{\text{Travel distance per revolution [degree] (AL)}} = \frac{4194304 \text{ pulses}}{360 \text{ degrees}} = \frac{524288}{45}$$

16. FULLY CLOSED LOOP SYSTEM

16.3.4 Fully closed loop control error detection functions

If fully closed loop control becomes unstable for some reason, the speed at servo motor side may increase abnormally. The fully closed loop control error detection function is a protective function designed to pre-detect it and stop operation.

The fully closed loop control error detection function has two different detection methods, speed deviation and position deviation, and errors are detected only when the corresponding functions are enabled by setting [Pr. PE03 Fully closed loop function selection 2].

The detection level setting can be changed using [Pr. PE06] and [Pr. PE07].

(1) Parameter

Select the fully closed loop control error detection function.

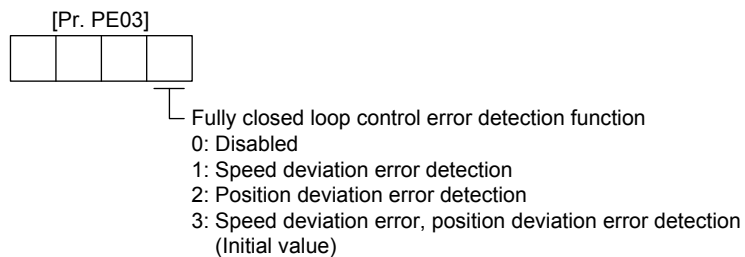

(2) Fully closed loop control error detection functions

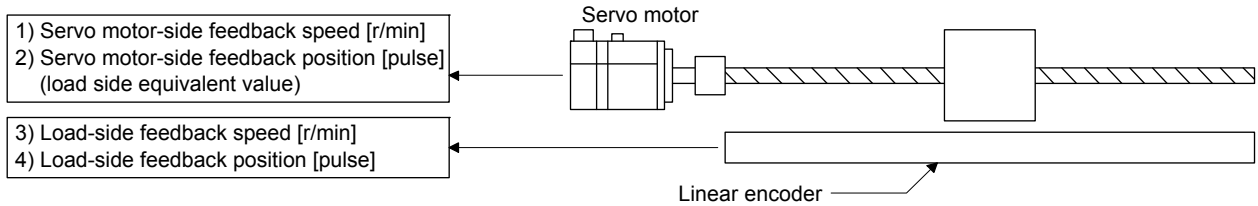

(a) Speed deviation error detection

Set [Pr. PE03] to " __ _ 1" to enable the speed deviation error detection.

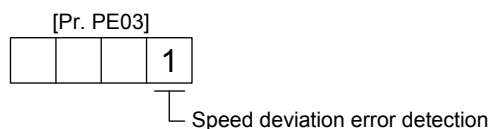

The function compares the servo motor-side feedback speed (1)) and load-side feedback speed (3)). If the deviation is not less than the set value (1 r/min to the permissible speed) of [Pr. PE06 Fully closed loop control speed deviation error detection level], the function generates [AL. 42.2 Servo control error by speed deviation] and stops. The initial value of [Pr. PE06] is 400 r/min. Change the set value as required.

16. FULLY CLOSED LOOP SYSTEM

(b) Position deviation error detection

Set [Pr. PE03] to "___2" to enable the position deviation error detection.

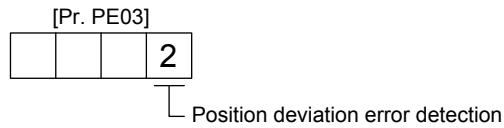

Comparing the servo motor-side feedback position (2)) and load-side feedback position (4)), if the deviation is not less than the set value (1 kpulses to 20000 kpulses) of [Pr. PE07 Fully closed loop control position deviation error detection level], the function generates [AL. 42.1 Servo control error by position deviation] and stops. The initial value of [Pr. PE07] is 100 kpulses. Change the set value as required.

(c) Detecting multiple deviation errors

When setting [Pr. PE03] as shown below, multiple deviation errors can be detected. For the error detection method, refer to (2) (a), (b) in this section.

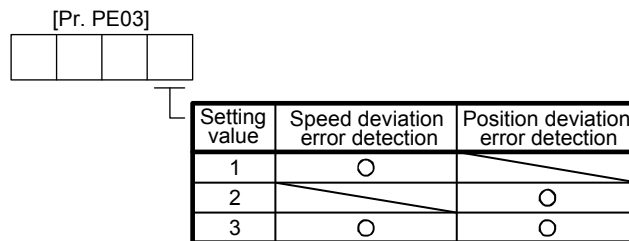

16.3.5 Auto tuning function

Refer to section 6.3 for the auto tuning function.

16.3.6 Machine analyzer function

Refer to Help of MR Configurator2 for the machine analyzer function of MR Configurator2.

16.3.7 Test operation mode

Test operation mode is enabled by MR Configurator2.

For details on the test operation mode, refer to section 4.5.

| Function | Item | Usability | Remark |
|---------------------|----------------------------------|-----------|------------------------------------------------------------------------------------|
| Test operation mode | JOG operation | ○ | It drives in the load-side encoder resolution unit |
| | Positioning operation | ○ | The fully closed loop system is operated in the load-side encoder resolution unit. |
| | Program operation | ○ | For details, refer to section 4.5.1 (1) (c). |
| | Output signal (DO) forced output | ○ | Refer to section 4.5.1 (1) (b). |
| | Motor-less operation | / | / |

16. FULLY CLOSED LOOP SYSTEM

16.3.8 Absolute position detection system under fully closed loop system

An absolute type linear encoder is necessary to configure an absolute position detection system under fully closed loop control using a linear encoder. In this case, the encoder battery need not be installed to the servo amplifier. When an rotary encoder is used, an absolute position detection system can be configured by installing the encoder battery to the servo amplifier. In this case, the battery life will be shorter because the power consumption is increased as the power is supplied to the two encoders of motor side and load side. For the absolute position detection system with linear encoder, the restrictions mentioned in this section apply. Enable the absolute position detection system with [Pr. PA03 Absolute position detection system] and use this servo within the following restrictions.

(1) Using conditions

- (a) Use an absolute type linear encoder with the load-side encoder.
- (b) Select Always fully closed loop ([Pr. PA01] = __ 1 _ and [Pr. PE01] = ___ 0).

(2) Absolute position detection range using encoder

| Encoder type | Absolute position detection enabled range |
|--------------------------------------|---------------------------------------------------------------------------------|
| Linear encoder (Serial Interface) | Movable distance range of linear encoder (within 32-bit absolute position data) |

(3) Alarm detection

The absolute position-related alarm ([AL. 25]) and warnings (AL. 92] and [AL. 9F]) are not detected.

16. FULLY CLOSED LOOP SYSTEM

16.3.9 About MR Configurator2

Using MR Configurator2 can confirm if the parameter setting is normal or if the servo motor and the load-side encoder operate properly.

This section explains the fully closed diagnosis screen.

Click "Monitor start" to constantly read the monitor display items from the servo amplifier.

Then, click "Monitor stop" to stop reading. Click "Parameter read" to read the parameter items from the servo amplifier, and then click "Parameter write" to write them.

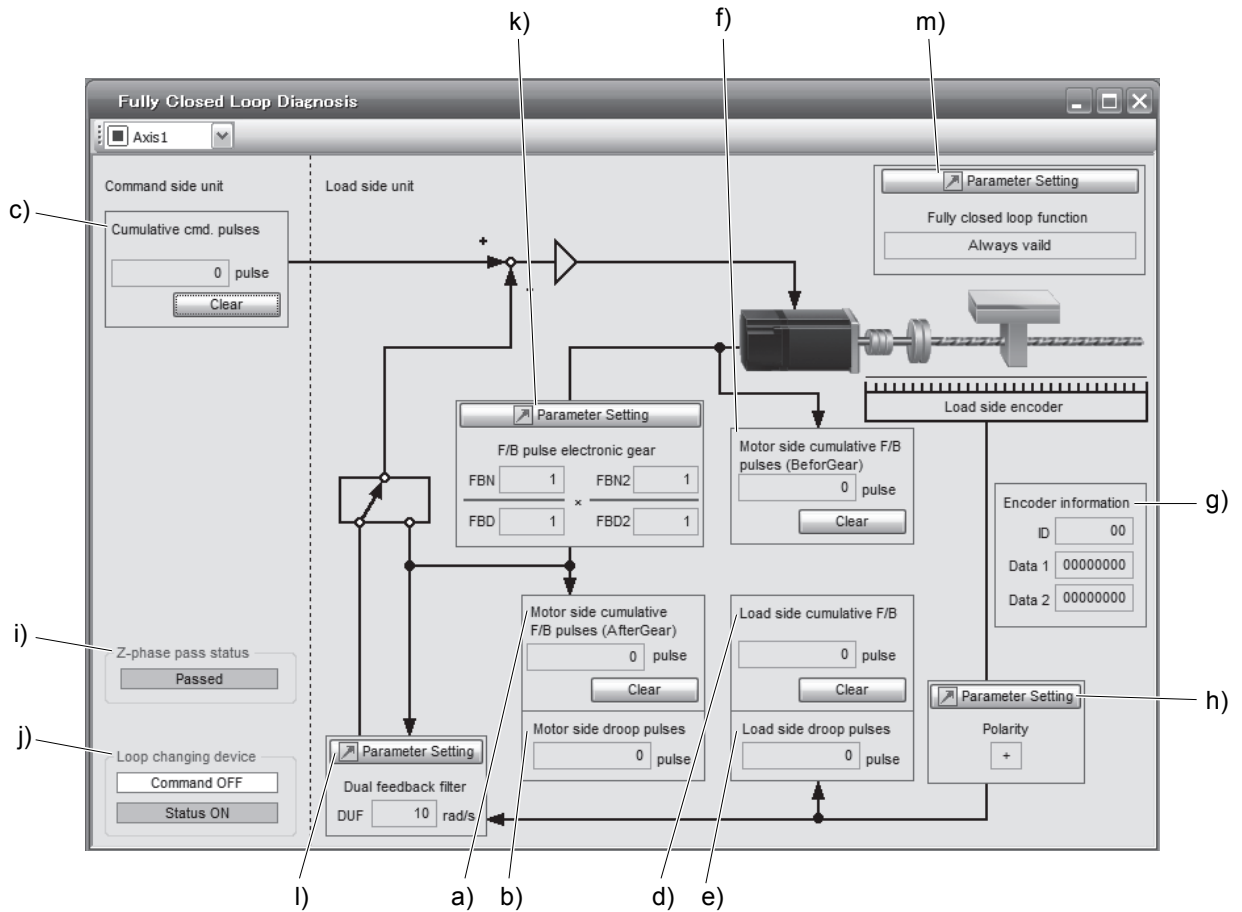

| Symbol | Name | Explanation | Unit |
|--------|-----------------------------------------------|---------------------------------------------------------------------------------------------------------------------------------------------------------------------------------------------------------------------------------------------------|-------|
| a) | Motor side cumu. feedback pulses (after gear) | Feedback pulses from the servo motor encoder are counted and displayed. (load-side encoder unit) When the set value exceeds 999999999, it starts with 0. Click "Clear" to reset the value to 0. The "-" symbol is indicated for reverse. | pulse |
| b) | Motor side droop pulses | Droop pulses of the deviation counter between a servo motor-side position and a command are displayed. The "-" symbol is indicated for reverse. | pulse |
| c) | Cumu. Com. pulses | Position command input pulses are counted and displayed. Click "Clear" to reset the value to 0. The "-" symbol is indicated for reverse command. | pulse |
| d) | Load side cumu. feedback pulses | Feedback pulses from the load-side encoder are counted and displayed. When the set value exceeds 999999999, it starts with 0. Click "Clear" to reset the value to 0. The "-" symbol is indicated for reverse. | pulse |
| e) | Load side droop pulses | Droop pulses of the deviation counter between a load-side position and a command are displayed. The "-" symbol is indicated for reverse. | pulse |

16. FULLY CLOSED LOOP SYSTEM

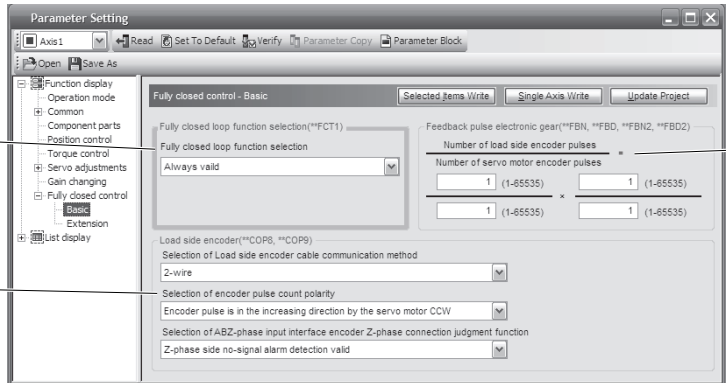
| Symbol | Name | Explanation | Unit |
|--------|------------------------------------------------|------------------------------------------------------------------------------------------------------------------------------------------------------------------------------------------------------------------------------------------------------------------------------------------------------------------------------------------------------------------------------------------------------------------------------------------------------------------------------------------------------------------------------------------------------------------------------------------------------------------------------------------------------------------------------------------------------------------------------------------------|-------|
| f) | Motor side cumu. feedback pulses (before gear) | Feedback pulses from the servo motor encoder are counted and displayed. (Servo motor encoder unit) When the set value exceeds 999999999, it starts with 0. Click "Clear" to reset the value to 0. The "-" symbol is indicated for reverse. | pulse |
| g) | Encoder information | The load-side encoder information is displayed. The display contents differ depending on the load-side encoder type. <ul style="list-style-type: none"> • ID: The ID No. of the load-side encoder is displayed. • Data 1: For the incremental type linear encoder, the counter from powering on is displayed. For the absolute position type linear encoder, the absolute position data is displayed. • Data 2: For the incremental type linear encoder, the distance (number of pulses) from the reference mark (Z-phase) is displayed. For the absolute position type linear encoder, "00000000" is displayed. | |
| h) | Polarity | For address increasing direction in the servo motor CCW, it is indicated as "+" and for address decreasing direction in the servo motor CCW, as "-". | |
| i) | Z phase pass status | If the fully closed loop system is "Disabled", the Z-phase pass status of the servo motor encoder is displayed. If the fully closed loop system is "Enabled" or "Semi closed loop control/fully closed loop control switching", the Z-phase pass status of the load-side encoder is displayed. | |
| j) | Fully closed loop changing device | Only if the fully closed loop system is "Semi closed loop control/fully closed loop control switching", the device is displayed. The state of the semi closed loop control/fully closed loop control switching bit and the inside state during selection are displayed. | |
| k) | Parameter (Feedback pulse electronic gear) | Display/set the feedback pulse electronic gears ([Pr. PE04], [Pr. PE05], [Pr. PE34], and [Pr. PE35]) for servo motor encoder pulses in this parameter. (Refer to section 16.3.1 (4).) | |
| l) | Parameter (Dual feedback filter) | Display/set the band of [Pr. PE08 Fully closed loop dual feedback filter] in this parameter. | |
| m) | Parameter (fully closed loop selection) | Display/set the parameter for the fully closed loop control. Click "Parameter setting" button to display the "Fully closed loop control - Basic" window. <div style="text-align: center;">  </div> <ol style="list-style-type: none"> Fully closed loop selection ([Pr. PE01]) Select "Always valid" or "Switching with the control command of controller" here. Feedback pulse electronic gear ([Pr. PE04], [Pr. PE05], [Pr. PE34], [Pr. PE35]) Set the feedback pulse electronic gear. Selection of encoder pulse count polarity ([Pr. PC27]) Select a polarity of the load-side encoder information. | |

17. APPLICATION OF FUNCTIONS

17. APPLICATION OF FUNCTIONS

17.1 J3 compatibility mode

| POINT |
|-------------------------------------------------------------------------------------------------------------------------------------------------------------------------------------------------------------------------------------------------------------------------------------------------------------------------------------------------------------------------------------------------------------------------------------------------------------------------------------------------------------------------------------------------------------------------------|
| <ul style="list-style-type: none"> ● The J3 compatibility mode is compatible only with HG series servo motors. ● The fully closed loop control in the J3 compatibility mode is available for the servo amplifiers with software version A3 or later. ● Specifications of the J3 compatibility mode of the servo amplifier with software version A4 or earlier differ from those with software version A5 or later. Refer to section 17.1.8. ● The J3 compatibility mode is not compatible with the master-slave operation function. |

17.1.1 Outline of J3 compatibility mode

MR-J4W-_B servo amplifiers and MR-J4-_B servo amplifiers have two operation mode: "J4 mode" is for using all functions with full performance and "J3 compatibility mode" for using the conventional MR-J3-B servo amplifiers.

When you connect an amplifier with SSCNET III/H communication for the first controller communication by factory setting, the operation mode will be fixed to "J4 mode". For SSCNET communication, it will be fixed to "J3 compatibility mode". When you set the mode back to the factory setting or change the mode, use the application "MR-J4(W)-B mode selection".

The application "MR-J4(W)-B mode selection" is packed with MR Configurator2 of software version 1.12N or later.

For the operating conditions of the application "MR-J4(W)-B mode selection", use MR Configurator2. (Refer to section 11.4.)

17.1.2 Operation modes supported by J3 compatibility mode

The J3 compatibility mode supports the following operation modes.

| Operation mode in J3 compatibility mode | Model of MR-J3-_B | Model of MR-J3-_BS | Model of MR-J3W-_B |
|----------------------------------------------------|-------------------|--------------------|--------------------|
| MR-J3-B standard control mode (rotary servo motor) | MR-J3-_B | MR-J3-_BS | MR-J3W-_B |
| MR-J3-B fully closed loop control mode | MR-J3-_B-RJ006 | MR-J3-_BS | |
| MR-J3-B linear servo motor control mode | MR-J3-_B-RJ004 | | MR-J3W-_B |
| MR-J3-B DD motor control mode | MR-J3-_B-RJ080W | | MR-J3W-_B |

Each operation mode has the same ordering as conventional MR-J3-B series servo amplifiers and is compatible with their settings.

In addition, the control response characteristic in the J3 compatibility mode will be the same as that of MR-J3 series.

17. APPLICATION OF FUNCTIONS

17.1.3 J3 compatibility mode supported function list

The following shows functions which are compatible with J4 mode and J3 compatibility mode. The letters such as "A0" described after ◎ and ○ mean servo amplifier software versions which compatible with each function. Each function is used with servo amplifiers with these software versions or later.

| Function | Name | Compatibility (◎: J4 new, ○: Equivalent to J3, ×: Not available) | | |
|--------------------------------------------------------|---------------------------------------------------------|---------------------------------------------------------------------|--------------------------------------------------------------|------------------------------------------------|
| | | MR-J4 series | | MR-J3/MR-J3W series (Note 8) |
| | | J4 mode | J3 compatibility mode | |
| Basic specification | Speed frequency response | 2.5 kHz | 2.1 kHz | 2.1 kHz |
| | Encoder resolution | 22 bits (Note 1) | 18 bits (Note 1) | 18 bits |
| SSCNET III/H communication or SSCNET III communication | Communication baud rate | 150 Mbps | 50 Mbps | 50 Mbps |
| | Maximum distance between stations | 100 m | 50 m | 50 m |
| Basic function | Absolute position detection system | ○ A0 | ○ A0 | ○ |
| | Fully closed loop control (Note 9) | ○ A3 (Two-wire type only) (Note 13) | ○ A3 (Two-wire type only) (Note 13) | MR-J3-_B-RJ006 MR-J3-_S |
| | Linear servo motor driving | ○ A0 (Two-wire type/ four-wire type only) (Note 13) | ○ A0 (Two-wire type/ four-wire type only) (Note 13) | MR-J3-_B-RJ004 MR-J3W-_B |
| | Direct drive motor driving | ○ A0 | ○ A0 | MR-J3-_B-RJ080W MR-J3W-_B |
| | Motor-less operation | ○ A0 (Note 2) | ○ A0 (Note 2) | ○ |
| | Rotation direction selection/travel direction selection | ○ A0 | ○ A0 | ○ |
| Encoder output pulses | A/B-phase pulse output | ○ A0 (Note 3) | ○ A0 (Note 3) | ○ |
| | Z-phase pulse output | ○ A0 (Note 4) | ○ A0 (Note 4) | ○ (Note 4) |
| Input/output | Analog monitor output | ○ A0 (Note 5) | ○ A0 (Note 5) | ○ |
| | Motor thermistor | ○ A0 | ○ A0 | MR-J3-_B-RJ004 MR-J3-_B-RJ080W MR-J3W-_B |
| Control mode | Position control mode | ○ A0 | ○ A0 | ○ |
| | Speed control mode | ○ A0 | ○ A0 | ○ |
| | Torque control mode | ○ A0 | ○ A0 | ○ |
| | Continuous operation to torque control mode | ○ A0 | ○ A0 | ○ |
| Auto tuning | Auto tuning mode 1 | ○ A0 | ○ A0 | ○ |
| | Auto tuning mode 2 | ○ A0 | ○ A0 | ○ |
| | 2 gain adjustment mode 1 (interpolation mode) | ○ A0 | ○ A0 | ○ |
| | 2 gain adjustment mode 2 | ◎ A0 | × | × |
| | Manual mode | ○ A0 | ○ A0 | ○ |
| Filter function | Machine resonance suppression filter 1 | ○ A0 | ○ A0 | ○ |
| | Machine resonance suppression filter 2 | ○ A0 | ○ A0 | ○ |
| | Machine resonance suppression filter 3 | ◎ A0 | ◎ B0 (Note 15) | × |
| | Machine resonance suppression filter 4 | ◎ A0 | ◎ B0 (Note 15) | × |
| | Machine resonance suppression filter 5 | ◎ A0 | ◎ B0 (Note 15) | × |
| | Shaft resonance suppression filter | ○ A0 | ◎ B0 (Note 15) | × |
| | Low-pass filter | ○ A0 | ○ A0 | ○ |
| | Robust disturbance compensation (Note 10) | × | ○ A0 | ○ |
| Robust filter | ◎ A0 | ◎ B0 (Note 15) | × | |

17. APPLICATION OF FUNCTIONS

| Function | Name | Compatibility (◎: J4 new, ○: Equivalent to J3, ×: Not available) | | |
|-------------------------------|----------------------------------------------------------------------------------------|---------------------------------------------------------------------|-----------------------|-----------------------------------------------------------|
| | | MR-J4 series | | MR-J3/MR-J3W series (Note 8) |
| | | J4 mode | J3 compatibility mode | |
| Vibration suppression control | Standard mode/3 inertia mode | ◎ A0 | ◎ B0 (Note 15) | × |
| | Vibration suppression control 1 | ○ A0 | ○ A0 | ○ |
| | Vibration suppression control 2 | ◎ A0 | ◎ B0 (Note 15) | × |
| | Command notch filter | ○ A0 | ○ A0 | ○ |
| Applied control | Gain switching | ○ A0 | ○ A0 | ○ |
| | Slight vibration suppression control | ○ A0 | ○ A0 | ○ |
| | Overshoot amount compensation | ○ A0 | ○ A0 | ○ |
| | PI-PID switching control | ○ A0 | ○ A0 | ○ |
| | Feed forward | ○ A0 | ○ A0 | ○ |
| | Torque limit | ○ A0 | ○ A0 | ○ |
| | Master-slave operation function | ○ A8 (Note 5) | × | ○ |
| | Scale measurement function | ◎ A8 (Note 3) | × | × |
| | Model adaptive control disabled | ○ B4 | ○ B4 | × |
| | Lost motion compensation function | ◎ B4 (Note 5) | ◎ (Note 5, 15) | × |
| | Super trace control | ◎ B4 (Note 5) | × | × |
| Adjustment function | One-touch tuning | ◎ A0 | ◎ B0 (Note 15) | × |
| | Adaptive tuning | ○ A0 | ○ A0 | ○ |
| | Vibration suppression control 1 tuning | ○ A0 | ○ A0 | ○ |
| | Vibration suppression control 2 tuning | ◎ A0 | ◎ B0 (Note 15) | × |
| Fully closed loop control | Fully closed loop electronic gear | ○ A3 | ○ A3 | MR-J3-_S MR-J3-_B-RJ006 |
| | Dual feedback control | ○ A3 | ○ A3 | |
| | Semi closed/fully closed switching loop control | ○ A3 | ○ A3 | |
| | Fully closed loop control error detection function | ○ A3 | ○ A3 | |
| Linear compatible | Linear servo control error detection function | ○ A0 | ○ A0 | MR-J3-_B-RJ004 MR-J3W-_B |
| | Servo motor series/types setting function | ○ A0 | ○ A0 | |
| Magnetic pole detection | Direct current exciting method magnetic pole detection | ○ A0 | ○ A0 | MR-J3-_B-RJ004 MR-J3-_B-RJ080W MR-J3W-_B |
| | Current detection method magnetic pole detection | × (Note 6) | ○ A0 | MR-J3-_B-RJ004 MR-J3W-_B |
| | Minute position detection method magnetic pole detection | ○ A0 | ○ A0 | MR-J3-_B-RJ004 MR-J3-_B-RJ080W MR-J3W-_B |
| | Initial magnetic pole detection error detection function | ○ A0 | ○ A0 | |
| Encoder | Semi closed loop control two-wire type/four-wire type selection | ○ A0 | ○ A0 | ○ |
| | Serial interface compatible linear encoder | ○ A0 | ○ A0 | MR-J3-_S MR-J3-_B-RJ006 MR-J3-_B-RJ004 MR-J3W-_B |
| | Pulse train interface (A/B/Z-phase differential output type) compatible linear encoder | ○ A5 (Note 14) | ○ A5 (Note 14) | MR-J3-_S MR-J3-_B-RJ006 MR-J3-_B-RJ004 |
| Functional safety | STO function | ○ A0 | ○ A0 | MR-J3-_S |
| | Forced stop deceleration function at alarm occurrence | ○ A0 | ○ A0 (Note 12) | MR-J3-_S |
| | Vertical axis freefall prevention function | ○ A0 | ○ A0 | MR-J3-_S |

17. APPLICATION OF FUNCTIONS

| Function | Name | Compatibility (◎: J4 new, ○: Equivalent to J3, ×: Not available) | | |
|----------------------|------------------------------------------------------------------|---------------------------------------------------------------------|-----------------------|---------------------------------|
| | | MR-J4 series | | MR-J3/MR-J3W series (Note 8) |
| | | J4 mode | J3 compatibility mode | |
| Tough drive function | SEMI-F47 function | ◎ A0 | ◎ B0 (Note 15, 16) | × |
| | Vibration tough drive | ◎ A0 | ◎ B0 (Note 15) | × |
| | Instantaneous power failure tough drive | ◎ A0 | ◎ B0 (Note 15) | × |
| Diagnosis function | 3-digit alarm display | ◎ A0 | ◎ A0 | MR-J3W-_B |
| | 16 alarm histories supported | ◎ A0 | × (Note 7) | × (Note 7) |
| | Drive recorder function | ◎ A0 | ◎ B0 (Note 15) | × |
| | Machine diagnosis function | ◎ A0 | ◎ B0 (Note 15) | × |
| Controller | SSCNET III | × | ○ A0 | ○ |
| | SSCNET III/H | ◎ A0 | × | × |
| | Home position return function | ○ A0 | ○ A0 | ○ |
| Others | J4 mode/J3 compatibility mode automatic identification (Note 11) | ○ A0 | ○ A0 | × |
| | Power monitoring function | ◎ A0 | ◎ B0 (Note 15) | × |

- Note
- The value is at the HG series servo motor driving.
 - The motor-less operation cannot be used in the fully closed loop control mode, linear servo motor control mode, or DD motor control mode.
 - It is not available with MR-J4W3-_B servo amplifiers.
 - It is not available with the MR-J3W-_B, MR-J4W2-_B, and MR-J4W3-_B servo amplifiers.
 - It is not available with the MR-J4W2-_B and MR-J4W3-_B servo amplifiers.
 - The minute position detection method is available instead.
 - Alarm history will be saved up to six times.
 - The functions of the product with modified parts (GA) in the MR-J3-_B servo amplifiers are all covered by the J3 compatibility mode of the MR-J4-_B servo amplifiers.
 - MR-J4W3-_B servo amplifiers do not support the fully closed loop control system.
 - For MR-J4 series, the robust filter and vibration tough drive are available instead.
 - The operation mode will be identified automatically at the first controller communication. You can change the operation mode with the application "MR-J4(W)-B mode selection".
 - When MR-J4 is used as a replacement of MR-J3-_S, "Servo forced stop selection" in [Pr. PA04] will be "Disabled (_ 1 _)" in the initial setting. Change the setting as necessary.
 - This is for MR-J4-_B servo amplifier. MR-J4-_B-RJ servo amplifier is compatible with two-wire type, four-wire type, and A/B/Z-phase differential output method.
 - It is available with only MR-J4-_B-RJ servo amplifiers. It is not available with MR-J4-_B servo amplifiers.
 - This is available when the J3 extension function is enabled. Refer to section 17.1.9 for details.
 - For servo system controllers which are available with this, contact your local sales office.

17. APPLICATION OF FUNCTIONS

17.1.4 How to switch J4 mode/J3 compatibility mode

There are two ways to switch the J4 mode/J3 compatibility mode with the MR-J4W_ _B servo amplifier and MR-J4_ _B_(-RJ) servo amplifier.

(1) Mode selection by the automatic identification of the servo amplifier

J4 mode/J3 compatibility mode is identified automatically depending on the connected controller.

When the controller makes a connection request with SSCNET III/H communication, the mode will be "J4 mode". For SSCNET communication, it will be "J3 compatibility mode".

For the J3 compatibility mode, standard control, linear servo motor control, or direct drive motor control will be identified automatically with a motor (encoder) connected to the servo amplifier. For the J4 mode, the operation mode will be the setting of [Pr. PA01].

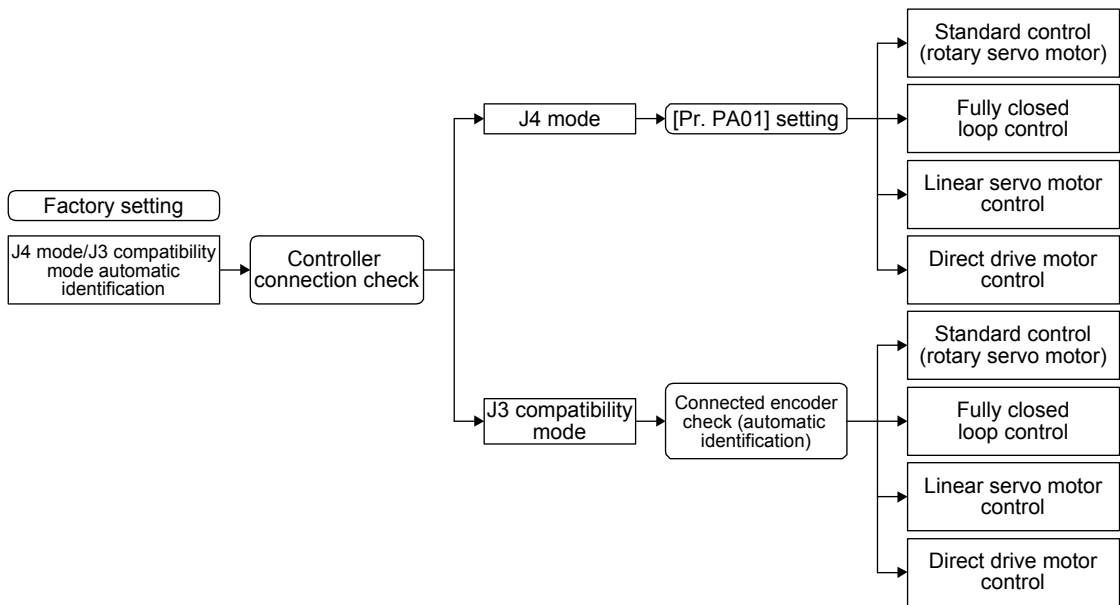

17. APPLICATION OF FUNCTIONS

(2) Mode selection using the application software "MR-J4(W)-B mode selection"

You can set the factory setting, J4 mode/J3 compatibility mode, and operation mode with the dedicated application.

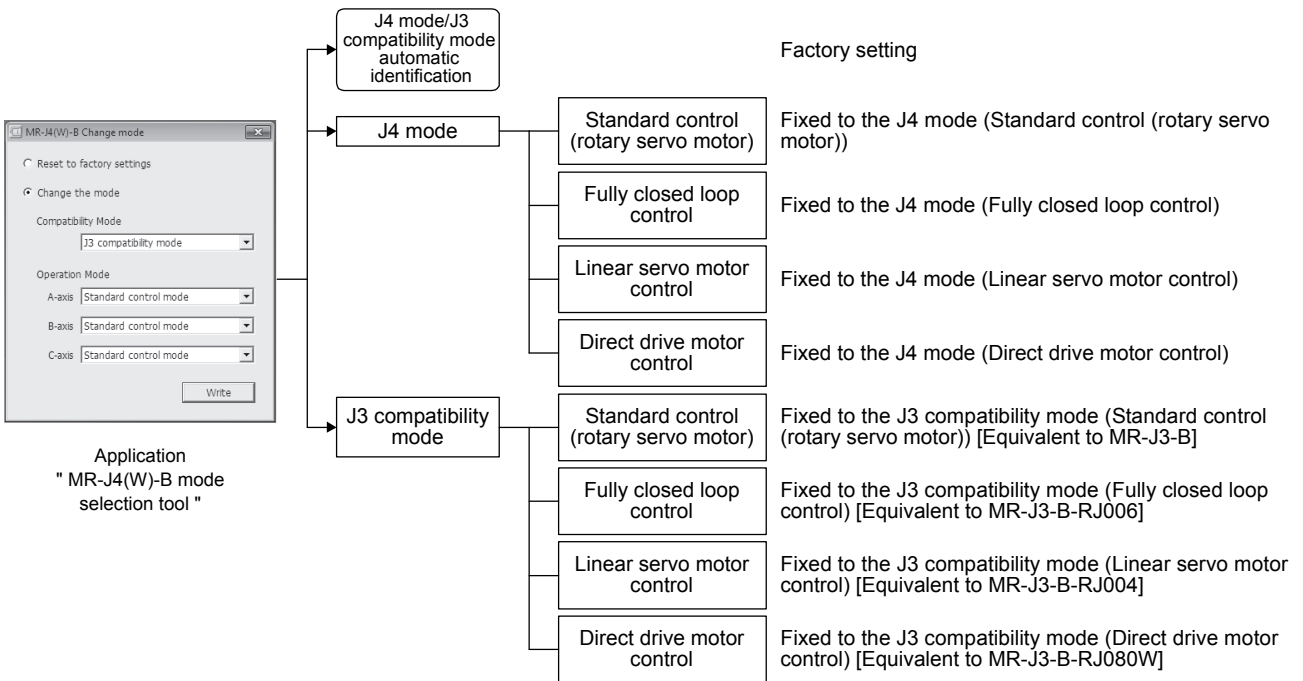

17.1.5 How to use the J3 compatibility mode

(1) Setting of the controller

To use in the J3 compatibility mode, select MR-J3 series in the system setting window.

| Operation mode in J3 compatibility mode | System setting |
|----------------------------------------------------|-------------------------------|
| MR-J3-B standard control mode (rotary servo motor) | Select MR-J3-_B. |
| MR-J3-B fully closed loop control mode | Select MR-J3-_B fully closed. |
| MR-J3-B linear servo motor control mode | Select MR-J3-_B linear. |
| MR-J3-B DD motor control mode | Select MR-J3-_B DDM. |

(2) Setting of MR Configurator

To use in the J3 compatibility mode, make the system setting as follows.

| Operation mode in J3 compatibility mode | System setting |
|----------------------------------------------------|-------------------------------|
| MR-J3-B standard control mode (rotary servo motor) | Select MR-J3-_B. |
| MR-J3-B fully closed loop control mode | Select MR-J3-_B fully closed. |
| MR-J3-B linear servo motor control mode | Select MR-J3-_B linear. |
| MR-J3-B DD motor control mode | Select MR-J3-_B DDM. |

Cautions for using MR Configurator

- The gain search cannot be used. You can use the advanced gain search.
- The C-axis of MR-J4W3-_B cannot be set with MR Configurator. Use MR Configurator2 for it.

17. APPLICATION OF FUNCTIONS

(3) Setting of MR Configurator2

To use in the J3 compatibility mode, make the system setting as follows.

| Operation mode in J3 compatibility mode | System setting |
|----------------------------------------------------|-------------------------------|
| MR-J3-B standard control mode (rotary servo motor) | Select MR-J3-_B. |
| MR-J3-B fully closed loop control mode | Select MR-J3-_B fully closed. |
| MR-J3-B linear servo motor control mode | Select MR-J3-_B linear. |
| MR-J3-B DD motor control mode | Select MR-J3-_B DDM. |

Cautions for using MR Configurator2

- Use MR Configurator2 with software version 1.12N or later. Older version than 1.12N cannot be used.
- Information about existing models (MR-J3) cannot be updated with the parameter setting range update function. Register a new model to use.
- The alarm will be displayed by 3 digits.
- The robust disturbance compensation cannot be used.

17.1.6 Cautions for switching J4 mode/J3 compatibility mode

The J3 compatibility mode of the operation mode is automatically identified by factory setting depending on a connected encoder. If a proper encoder is not connected at the first connection, the system will not start normally due to a mismatch with a set mode with the controller. (For the J4 mode, you can set the operation mode with [Pr. PA01].) For example, if the controller is connected without connecting a linear encoder at linear servo motor driving, the servo amplifier will be the standard control mode (rotary servo motor). The system will not start because the controller is connected with the linear servo motor driving amplifier. When the operation mode mismatches, the servo amplifier will display [AL. 3E.1 Operation mode error]. Set the mode back to the factory setting or set correctly (J4 mode/J3 compatibility mode and operation mode) using the application "MR-J4(W)-B mode selection".

17.1.7 Cautions for the J3 compatibility mode

The J3 compatibility mode are partly changed and has restrictions compared with MR-J3 series.

- (1) The alarm display was changed from 2 digits (__) to 3 digits (__.). The alarm detail number (.) is displayed in addition to the alarm No (__). The alarm No. (__) is not changed.
- (2) When the power of the servo amplifier is cut or fiber-optic cable is disconnected, the same type communication can be cut regardless of connection order. When you power on/off the servo amplifier during operation, use the connect/disconnect function of the controller. Refer to the following manuals for detail.
 - MELSEC iQ-R Motion Controller Programming Manual (Common) (R16MTCPU/R32MTCPU) (IB-0300237) "5.3.1 Connect/disconnect function of SSCNET communication"
 - Motion controller Q series Programming Manual COMMON (Q173D(S)CPU/Q172D(S)CPU) (IB-0300134) "4.11.1 Connect/disconnect function of SSCNET communication"
 - MELSEC iQ-R Simple Motion Module User's Manual (Application) (RD77MS2/RD77MS4/RD77MS8/RD77MS16) (IB-0300247) "8.12 Connect/disconnect function of SSCNET communication"
 - MELSEC-Q QD77MS Simple Motion Module User's Manual (IB-0300185) "14.12 Connect/disconnect function of SSCNET communication"
 - MELSEC-L LD77MH Simple Motion Module User's Manual (IB-0300172) "14.13 Connect/disconnect function of SSCNET communication"
 - MELSEC-L LD77MS Simple Motion Module User's Manual (Positioning Control) (IB-0300211) "14.13 Connect/disconnect function of SSCNET communication"

17. APPLICATION OF FUNCTIONS

- (3) The J3 compatibility mode has a functional compatibility. However, the operation timing may differ. Check the operation timing on customer side to use.
- (4) The J3 compatibility mode is not compatible with high-response control set by [Pr. PA01 Operation mode].
- (5) For MR-J3 series, a linear encoder was connected to the CN2L connector. For J4 (J3 compatibility mode), it is connected to the CN2 connector. Therefore, set the two-wire/four-wire type of the linear encoder in the J3 compatibility mode with [Pr. PC26], not with [Pr. PC04].
- (6) When you use a linear servo motor, select linear servo motor with [Pr. PA17] and [Pr. PA18].

17. APPLICATION OF FUNCTIONS

17.1.8 Change of specifications of "J3 compatibility mode" switching process

(1) Detailed explanation of "J3 compatibility mode" switching

(a) Operation when using a servo amplifier before change of specifications

For the controllers in which "Not required" is described to controller reset in table 17.1, the mode will be switched to "J3 compatibility mode" for all axes at the first connection. However, it takes about 10 s per axis for completing the connection.

For the controllers in which "Reset required" is described in table 17.1, the operation at the first connection is shown in table 17.2. The LED displays will be "Ab." for all axes at the first connection to the controller as shown in table 17.2. After that, resetting controller will change the 1-axis to "b01". The 2-axis and later will not change from "Ab.". After that, one axis will be connected per two times of controller reset.

Table 17.1 Controller reset required/not required list (before change of specifications)

| Controller | Model | Controller reset required/not required | |
|--------------------------------------------|--------------|----------------------------------------|-----------------------|
| | | Single-axis connection | Multi-axis connection |
| Motion controller | R_MTCPU | Not required | Not required |
| | Q17_DSCPU | Not required | Not required |
| | Q17_DCPU | Not required | Not required |
| | Q17_HCPU | Not required | Not required |
| | Q170MCPUCPU | Not required | Not required |
| Simple motion module Positioning module | RD77MS_ | Not required | Not required |
| | QD77MS_ | Not required | Not required |
| | LD77MS_ | Not required | Not required |
| | QD75MH_ | Not required | Not required |
| | QD74MH_ | Reset required | Reset required |
| | LD77MH_ | Not required | Not required |
| | FX3U-20SSC-H | Not required | Reset required |

Table 17.2 Controller connection operation before change of specifications

| | Before change of specifications (software version A4 or earlier) |
|--------------------------------|--------------------------------------------------------------------------------------------------------------------------------------------------------------------------------------------------------------|
| First connection of controller | <p>Controller "Ab." is displayed and stops</p> <p>Axis No. 1: A b . Axis No. 2: A b . Axis No. 3: A b .</p> |
| After controller reset | <p>Controller "b01" is displayed on axis No. 1, "Ab." is displayed on axis No. 2 and later.</p> <p>Axis No. 1: b 0 1 Axis No. 2: A b . Axis No. 3: A b .</p> <p>One axis is connected per reset.</p> |

17. APPLICATION OF FUNCTIONS

(b) Operation when using a servo amplifier after change of specifications

For the controllers in which "Not required" is described to controller reset in table 17.3, the mode will be switched to "J3 compatibility mode" for all axes at the first connection. It takes about 10 s for completing the connection not depending on the number of axes.

For the controllers in which "Reset required" is described in table 17.3, the operation at the first connection is shown in table 17.4. The servo amplifier's mode will be "J3 compatibility mode" and the LED displays will be "rST" for all axes at the first connection to the controller as shown in table 17.4. At the status, resetting controller once will change the display to "b##" (## means axis No.) for all axes and all axes will be ready to connect.

(One controller reset enables to all-axis connection.)

Table 17.3 Controller reset required/not required list (after change of specifications)

| Controller | Model | Controller reset required/not required | |
|--------------------------------------------|--------------|----------------------------------------|-----------------------|
| | | Single-axis connection | Multi-axis connection |
| Motion controller | R_MTCPU | Not required | Not required |
| | Q17_DSCPU | Not required | Not required |
| | Q17_DCPU | Not required | Not required |
| | Q17_HCPU | Not required | Not required |
| | Q170MCPUCPU | Not required | Not required |
| Simple motion module Positioning module | RD77MS_ | Not required | Not required |
| | QD77MS_ | Not required | Not required |
| | LD77MS_ | Not required | Not required |
| | QD75MH_ | Not required | Not required |
| | QD74MH_ | Reset required | Reset required |
| | LD77MH_ | Not required | Not required |
| | FX3U-20SSC-H | Reset required | Reset required |

Table 17.4 Controller connection operation after change of specifications

| | After change of specifications (software version A5 or later) |
|--------------------------------|---------------------------------------------------------------------|
| First connection of controller | <p>Controller "rST" is displayed only for the first connection.</p> |
| After controller reset | <p>Controller All axes are connected by one reset.</p> |

(c) Using servo amplifiers before and after change of specifications simultaneously

When using servo amplifiers before change of specifications and after change of specifications simultaneously, controller reset is necessary for number of connecting axes of servo amplifiers.

17. APPLICATION OF FUNCTIONS

(2) Changing the mode to "J3 compatibility mode" by using the application "MR-J4(W)-B mode selection". You can switch the servo amplifier's mode to "J3 compatibility mode" beforehand with the built-in application software "MR-J4(W)-B mode selection" of MR Configurator2. Use it for a solution when it is difficult to reset many times with your "Reset required" controller such as "QD74MH_". The application "MR-J4(W)-B mode selection" has no expiration date.

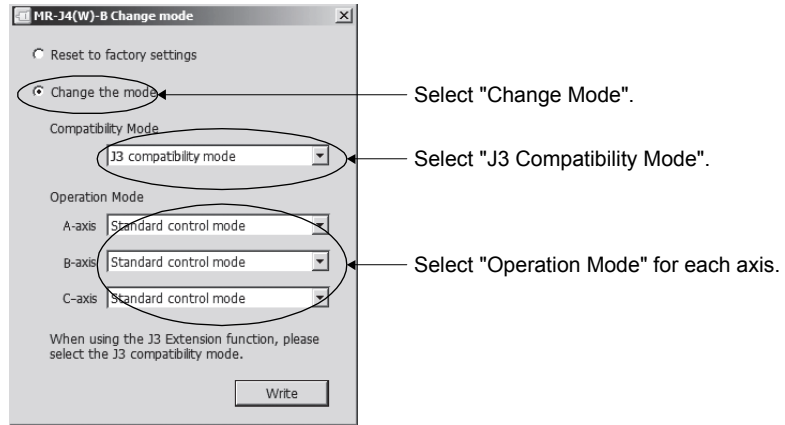

17.1.9 J3 extension function

| POINT |
|----------------------------------------------------------------------------------------------------------------------------------------------------------------------------------------------------------------------------------------------------------------------------------------------------------------------------------------------------------|
| <ul style="list-style-type: none"> ● The J3 extension function is used with servo amplifiers with software version B0 or later. ● To enable the J3 extension function, MR Configurator2 with software version 1.25B or later is necessary. ● The J3 extension function of the amplifier differs from MR-J3-B in motion. |

The J3 extension function is for using functions of J4 mode with J3 compatibility mode. By enabling the J3 extension function, you will get control response which is equal to MR-J4 series using a controller compatible with SSCNET III.

| J4 mode | J3 compatibility mode | |
|------------------------------------------------------------------------------------------------------------|-----------------------------------------------------------------------------------------------------------------------------------------------------------------------------------------------|--------------------------------------------------------------------------------------------------------------------------------|
| | J3 extension function enabled: [Pr. PX01] = "___1" | J3 extension function disabled: [Pr. PX01] = "___0" |
| <ul style="list-style-type: none"> • SSCNET III/H communication • MR-J4-B function | <ul style="list-style-type: none"> • SSCNET III communication • The same parameter ordering as MR-J3-B • MR-J4-B control function • Parameter added | <ul style="list-style-type: none"> • SSCNET III communication • The same parameter ordering as MR-J3-B |

17. APPLICATION OF FUNCTIONS

The following shows functions used with the J3 extension function.

| Function | Description | Detailed explanation |
|----------------------------------------------------------------------------------------------------------------------------|---------------------------------------------------------------------------------------------------------------------------------------------------------------------------------------------------------------------------------------------------------------------------------------------------------------------------------------------------------------------------------------------------------------------------------------------------------------------------------------------------------------------------------------------------------------------------------------------------------------------------|------------------------------------------------|
| Gain switching function (Vibration suppression control 2 and model loop gain) | You can switch gains during rotation/stop, and can use input devices to switch gains during operation. | Section 17.1.9 (6) |
| Advanced vibration suppression control II | This function suppresses vibration at the arm end or residual vibration. | Section 17.1.9 (5) (c) |
| Machine resonance suppression filter 3 Machine resonance suppression filter 4 Machine resonance suppression filter 5 | This is a filter function (notch filter) which decreases the gain of the specific frequency to suppress the resonance of the mechanical system. | Section 17.1.9 (5) (a) |
| Shaft resonance suppression filter | When a load is mounted to the servo motor shaft, resonance by shaft torsion during driving may generate a mechanical vibration at high frequency. The shaft resonance suppression filter suppresses the vibration. | Section 17.1.9 (5) (b) |
| Robust filter | This function provides better disturbance response in case low response level that load to motor inertia ratio is high for such as roll send axes. | [Pr. PX31] |
| One-touch tuning | Gain adjustment is performed just by one click on a certain button on MR Configurator2. MR Configurator2 is necessary for this function. | Section 17.1.9 (4) |
| Tough drive function | This function makes the equipment continue operating even under the condition that an alarm occurs. The tough drive function includes two types: the vibration tough drive and the instantaneous power failure tough drive. | Section 17.1.9 (7) |
| SEMI-F47 function (Note) | Enables to avoid triggering [AL. 10 Undervoltage] using the electrical energy charged in the capacitor in case that an instantaneous power failure occurs during operation. Use a 3-phase for the input power supply of the servo amplifier. Using a 1-phase 200 V AC for the input power supply will not comply with SEMI-F47 standard. | [Pr. PX25] [Pr. PX28] Section 17.1.9 (8) |
| Drive recorder function | This function continuously monitors the servo status and records the status transition before and after an alarm for a fixed period of time. You can check the recorded data on the drive recorder window on MR Configurator2 by clicking the "Graph" button. However, the drive recorder will not operate on the following conditions. 1. You are using the graph function of MR Configurator2. 2. You are using the machine analyzer function. 3. [Pr. PX30] is set to "-1". 4. The controller is not connected (except the test operation mode). 5. An alarm related to the controller is occurring. | [Pr. PX29] |
| Power monitoring function | This function calculates the power running energy and the regenerative power from the data in the servo amplifier such as speed and current. Power consumption and others are displayed on MR Configurator2 in the system of SSCNET III/H. Since the servo amplifier sends data to a servo system controller, you can analyze the data and display the data on a display. | |
| Machine diagnosis function | From the data in the servo amplifier, this function estimates the friction and vibrational component of the drive system in the equipment and recognizes an error in the machine parts, including a ball screw and bearing. MR Configurator2 is necessary for this function. | |

Note. For servo system controllers which are available with this, contact your local sales office.

17. APPLICATION OF FUNCTIONS

The following shows how to use the J3 extension function.

(1) Settings of J3 extension function

| POINT |
|-------------------------------------------------------------------------------------------------------------------------------------------------------------------------------------------------------------------------------------------------------------------------------------------------------------|
| <ul style="list-style-type: none">● To set the J3 extension function, connect a personal computer with MR Configurator2 of software version 1.25B or later to the servo amplifier with USB cable.● The extension control 2 parameters ([Pr. PX_ _]) cannot be set from a controller. |

To use the J3 the extension function, enable the setting of the extension control 2 parameters ([Pr. PX_ _]). Set as follows using MR Configurator2.

(a) Setting to enable the extension control 2 parameters ([Pr. PX_ _])

- 1) Open the "Project" menu and click "New" in MR Configurator2. The "New" window will be displayed.

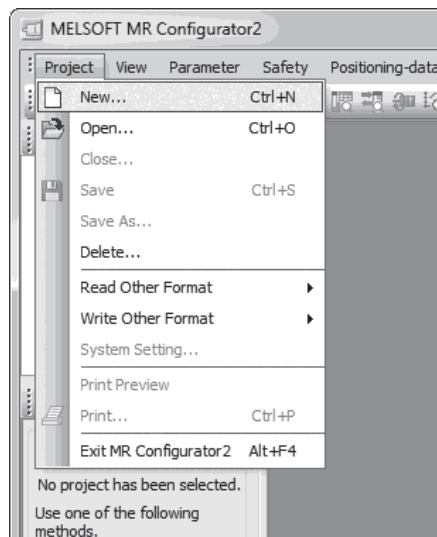

17. APPLICATION OF FUNCTIONS

- 2) Select "MR-J3-B extension function" of model selection in the "New" window and click "OK". The "Extension function change" window will be displayed.

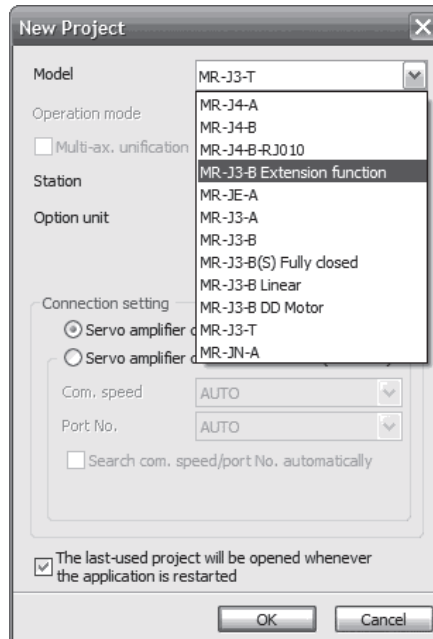

- 3) Click "Change to MR-J3-B extension function" in the "Extension function change" window and click "OK". Now, you can set the extension control 2 parameters ([Pr. PX_ _]).

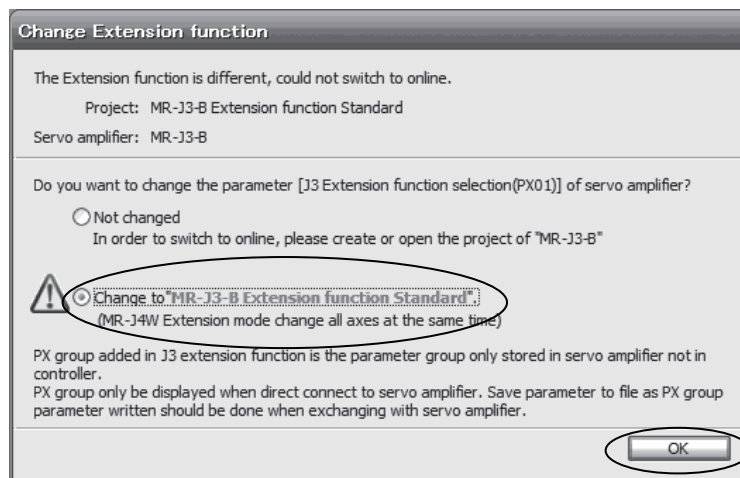

(b) Setting to enable the J3 extension function

To enable the J3 extension function, set [Pr. PX01] to " _ _ _ 1".

[Pr. PX01]

| | | | |
|---|---|---|--|
| 0 | 0 | 0 | |
|---|---|---|--|

J3 extension function selection
 0: Disabled
 1: Enabled

17. APPLICATION OF FUNCTIONS

(2) Extension control 2 parameters ([Pr. PX_ _])

CAUTION

- Never make a drastic adjustment or change to the parameter values as doing so will make the operation unstable.
- Do not change the parameter settings as described below. Doing so may cause an unexpected condition, such as failing to start up the servo amplifier.
 - Changing the values of the parameters for manufacturer setting
 - Setting a value out of the range
 - Changing the fixed values in the digits of a parameter
- When you write parameters with the controller, make sure that the control axis No. of the servo amplifier is set correctly. Otherwise, the parameter settings of another axis may be written, possibly causing the servo amplifier to be an unexpected condition.

POINT

- The parameter whose symbol is preceded by * is enabled with the following conditions:
 - *: After setting the parameter, cycle the power or reset the controller.
 - ** : After setting the parameter, cycle the power.
- Abbreviations of J3 compatibility mode indicate the followings.
 - Standard: Standard (semi closed loop system) use of the rotary servo motor
 - Full.: Fully closed loop system use of the rotary servo motor
 - Lin.: Linear servo motor use
 - DD: Direct drive (DD) motor use

| No. | Symbol | Name | Initial value | Unit | Each axis/ Common | J3 compatibility mode | | | |
|------|---------|---------------------------------------------------------------------------------------|---------------|---------|----------------------|-----------------------|-----------------------|-----------------------|-----------------------|
| | | | | | | Standard | Full. | Lin. | DD |
| PX01 | **J3EX | J3 extension function | 0000h | | Common | <input type="radio"/> | <input type="radio"/> | <input type="radio"/> | <input type="radio"/> |
| PX02 | XOP1 | Function selection X-1 | 0000h | | Each axis | <input type="radio"/> | <input type="radio"/> | <input type="radio"/> | <input type="radio"/> |
| PX03 | VRFTX | Vibration suppression control tuning mode (advanced vibration suppression control II) | 0000h | | Each axis | <input type="radio"/> | <input type="radio"/> | <input type="radio"/> | <input type="radio"/> |
| PX04 | VERF21 | Vibration suppression control 2 - Vibration frequency | 100.0 | [Hz] | Each axis | <input type="radio"/> | <input type="radio"/> | <input type="radio"/> | <input type="radio"/> |
| PX05 | VERF22 | Vibration suppression control 2 - Resonance frequency | 100.0 | [Hz] | Each axis | <input type="radio"/> | <input type="radio"/> | <input type="radio"/> | <input type="radio"/> |
| PX06 | VERF23 | Vibration suppression control 2 - Vibration frequency damping | 0.00 | | Each axis | <input type="radio"/> | <input type="radio"/> | <input type="radio"/> | <input type="radio"/> |
| PX07 | VERF24 | Vibration suppression control 2 - Resonance frequency damping | 0.00 | | Each axis | <input type="radio"/> | <input type="radio"/> | <input type="radio"/> | <input type="radio"/> |
| PX08 | VERF21B | Vibration suppression control 2 - Vibration frequency after gain switching | 0.0 | [Hz] | Each axis | <input type="radio"/> | <input type="radio"/> | <input type="radio"/> | <input type="radio"/> |
| PX09 | VERF22B | Vibration suppression control 2 - Resonance frequency after gain switching | 0.0 | [Hz] | Each axis | <input type="radio"/> | <input type="radio"/> | <input type="radio"/> | <input type="radio"/> |
| PX10 | VERF23B | Vibration suppression control 2 - Vibration frequency damping after gain switching | 0.00 | | Each axis | <input type="radio"/> | <input type="radio"/> | <input type="radio"/> | <input type="radio"/> |
| PX11 | VERF24B | Vibration suppression control 2 - Resonance frequency damping after gain switching | 0.00 | | Each axis | <input type="radio"/> | <input type="radio"/> | <input type="radio"/> | <input type="radio"/> |
| PX12 | PG1B | Model loop gain after gain switching | 0.0 | [rad/s] | Each axis | <input type="radio"/> | <input type="radio"/> | <input type="radio"/> | <input type="radio"/> |
| PX13 | *XOP2 | Function selection X-2 | 0001h | | Each axis | <input type="radio"/> | <input type="radio"/> | <input type="radio"/> | <input type="radio"/> |
| PX14 | OTHOV | One-touch tuning - Overshoot permissible level | 0 | [%] | Each axis | <input type="radio"/> | <input type="radio"/> | <input type="radio"/> | <input type="radio"/> |

17. APPLICATION OF FUNCTIONS

| No. | Symbol | Name | Initial value | Unit | Each axis/ Common | J3 compatibility mode | | | | |
|------|--------|----------------------------------------------------------------|------------------------------------|----------------|----------------------|-----------------------|-----------------------|-----------------------|-----------------------|-----------------------|
| | | | | | | Standard | Full. | Lin. | DD | |
| PX15 | | For manufacturer setting | 0000h | | | | | | | |
| PX16 | | | 0000h | | | | | | | |
| PX17 | NH3 | Machine resonance suppression filter 3 | 4500 | [Hz] | Each axis | <input type="radio"/> | <input type="radio"/> | <input type="radio"/> | <input type="radio"/> | |
| PX18 | NHQ3 | Notch shape selection 3 | 0000h | | Each axis | <input type="radio"/> | <input type="radio"/> | <input type="radio"/> | <input type="radio"/> | |
| PX19 | NH4 | Machine resonance suppression filter 4 | 4500 | [Hz] | Each axis | <input type="radio"/> | <input type="radio"/> | <input type="radio"/> | <input type="radio"/> | |
| PX20 | NHQ4 | Notch shape selection 4 | 0000h | | Each axis | <input type="radio"/> | <input type="radio"/> | <input type="radio"/> | <input type="radio"/> | |
| PX21 | NH5 | Machine resonance suppression filter 5 | 4500 | [Hz] | Each axis | <input type="radio"/> | <input type="radio"/> | <input type="radio"/> | <input type="radio"/> | |
| PX22 | NHQ5 | Notch shape selection 5 | 0000h | | Each axis | <input type="radio"/> | <input type="radio"/> | <input type="radio"/> | <input type="radio"/> | |
| PX23 | | For manufacturer setting | 0000h | | | | | | | |
| PX24 | FRIC | Machine diagnosis function - Friction judgment speed | 0 | [r/min]/[mm/s] | Each axis | <input type="radio"/> | <input type="radio"/> | <input type="radio"/> | <input type="radio"/> | |
| PX25 | *TDS | Tough drive setting | 0000h | | Each axis | <input type="radio"/> | <input type="radio"/> | <input type="radio"/> | <input type="radio"/> | |
| PX26 | OSCL1 | Vibration tough drive - Oscillation detection level | 50 | [%] | Each axis | <input type="radio"/> | <input type="radio"/> | <input type="radio"/> | <input type="radio"/> | |
| PX27 | *OSCL2 | Vibration tough drive function selection | 0000h | | Each axis | <input type="radio"/> | <input type="radio"/> | <input type="radio"/> | <input type="radio"/> | |
| PX28 | CVAT | SEMI-F47 function - Instantaneous power failure detection time | 200 | [ms] | Common | <input type="radio"/> | <input type="radio"/> | <input type="radio"/> | <input type="radio"/> | |
| PX29 | DRAT | Drive recorder arbitrary alarm trigger setting | 0000h | | Common | <input type="radio"/> | <input type="radio"/> | <input type="radio"/> | <input type="radio"/> | |
| PX30 | DRT | Drive recorder switching time setting | 0 | [s] | Common | <input type="radio"/> | <input type="radio"/> | <input type="radio"/> | <input type="radio"/> | |
| PX31 | XOP4 | Function selection X-4 | 0000h | | Each axis | <input type="radio"/> | <input type="radio"/> | <input type="radio"/> | <input type="radio"/> | |
| PX32 | | For manufacturer setting | 0 | | | | | | | |
| PX33 | | | 0.0 | | | | | | | |
| PX34 | | | 0.0 | | | | | | | |
| PX35 | | | 50 | | | | | | | |
| PX36 | | | 0 | | | | | | | |
| PX37 | | | 0 | | | | | | | |
| PX38 | | | 0 | | | | | | | |
| PX39 | | | 0 | | | | | | | |
| PX40 | | | 0000h | | | | | | | |
| PX41 | | | 0 | | | | | | | |
| PX42 | | | 0 | | | | | | | |
| PX43 | **STOD | | STO diagnosis error detection time | 0 | [s] | Common | <input type="radio"/> | <input type="radio"/> | <input type="radio"/> | <input type="radio"/> |
| PX44 | | | For manufacturer setting | 0000h | | | | | | |
| PX45 | | 0000h | | | | | | | | |
| PX46 | | 0000h | | | | | | | | |
| PX47 | | 0000h | | | | | | | | |
| PX48 | | 0000h | | | | | | | | |
| PX49 | | 0000h | | | | | | | | |
| PX50 | | 0000h | | | | | | | | |
| PX51 | | 0000h | | | | | | | | |
| PX52 | | 0000h | | | | | | | | |
| PX53 | | 0000h | | | | | | | | |
| PX54 | | 0000h | | | | | | | | |
| PX55 | | 0000h | | | | | | | | |
| PX56 | | 0000h | | | | | | | | |
| PX57 | | 0000h | | | | | | | | |
| PX58 | | 0000h | | | | | | | | |
| PX59 | | 0000h | | | | | | | | |
| PX60 | | 0000h | | | | | | | | |
| PX61 | | 0000h | | | | | | | | |
| PX62 | | 0000h | | | | | | | | |
| PX63 | | 0000h | | | | | | | | |
| PX64 | | 0000h | | | | | | | | |

17. APPLICATION OF FUNCTIONS

(3) Extension control 2 parameters ([Pr. PX__]) detailed list

| No. | Symbol | Name and function | Initial value [unit] | Setting range | Each/common | | | | | | | | | | | | |
|---------------|--------------------------------------------------------------------------------------------------------------------------------------------------------------------------------------------------------------------------------------------------------------------------------------------------------------------------------------------------------------------------------------------------------------------------------------------------------------------------------------------------------------------------------------------------------------------------------------------------------------------------------------------------------------------|-----------------------------------------------------------------------------------------------------------------------------------------------------------------------------------------------------------------------------------------------------------------------------------------------------------------------------------------------------------------------------------------------------------------------------------------------------------------------------------------------------------------------------------------------------------------------------------------------------------------------------------------------------------------------------------------------------------------------------------------------------------------------------------------------------------------------------------------------------------------------------------------------------------------------------------------------------------------------------------------------------------------------------------------------------------|----------------------|---------------|---------------|------|--------------------------------------------------------------------------------------------------------------------------------------------------------------------------------------------------------------------------------------------------------------------------------------------------------------------------------------------------------------------------------------------------------------------------------------------------------------------------------------------------------------------------------------------------------------------------------------------------------------------------------------------------------------------|----|------|--------------------------|----|------|----|------|----|------------------------------------|-----------|
| PX01 | **J3EX | <p>J3 extension function Select enabled or disabled of the J3 extension function.</p> <table border="1"> <thead> <tr> <th>Setting digit</th> <th>Explanation</th> <th>Initial value</th> </tr> </thead> <tbody> <tr> <td>___x</td> <td> <p>J3 extension function selection 0: Disabled 1: Enabled</p> <p>When you enable the J3 extension function selection, setting of [Pr. PX01] to [Pr. PX35] will be enabled and you will be able to also use functions in J4 mode with J3 compatibility mode. Additionally, the J3 extension function of the amplifier differs from MR-J3-B in motion.</p> </td> <td>0h</td> </tr> <tr> <td>__x_</td> <td rowspan="3">For manufacturer setting</td> <td>0h</td> </tr> <tr> <td>_x__</td> <td>0h</td> </tr> <tr> <td>x___</td> <td>0h</td> </tr> </tbody> </table> | Setting digit | Explanation | Initial value | ___x | <p>J3 extension function selection 0: Disabled 1: Enabled</p> <p>When you enable the J3 extension function selection, setting of [Pr. PX01] to [Pr. PX35] will be enabled and you will be able to also use functions in J4 mode with J3 compatibility mode. Additionally, the J3 extension function of the amplifier differs from MR-J3-B in motion.</p> | 0h | __x_ | For manufacturer setting | 0h | _x__ | 0h | x___ | 0h | Refer to Name and function column. | Common |
| Setting digit | Explanation | Initial value | | | | | | | | | | | | | | | |
| ___x | <p>J3 extension function selection 0: Disabled 1: Enabled</p> <p>When you enable the J3 extension function selection, setting of [Pr. PX01] to [Pr. PX35] will be enabled and you will be able to also use functions in J4 mode with J3 compatibility mode. Additionally, the J3 extension function of the amplifier differs from MR-J3-B in motion.</p> | 0h | | | | | | | | | | | | | | | |
| __x_ | For manufacturer setting | 0h | | | | | | | | | | | | | | | |
| _x__ | | 0h | | | | | | | | | | | | | | | |
| x___ | | 0h | | | | | | | | | | | | | | | |
| PX02 | XOP1 | <p>Function selection X-1</p> <table border="1"> <thead> <tr> <th>Setting digit</th> <th>Explanation</th> <th>Initial value</th> </tr> </thead> <tbody> <tr> <td>___x</td> <td> <p>Vibration suppression mode selection 0: Standard mode 1: 3 inertia mode 2: Low response mode</p> <p>When two low resonance frequencies are generated, select "3 inertia mode (___ 1)". When the load to motor inertia ratio exceeds the recommended load to motor inertia ratio, select "Low response mode (___ 2)".</p> <p>When you select the standard mode or low response mode, "Vibration suppression control 2" is not available. When you select the 3 inertia mode, the feed forward gain is not available.</p> <p>Before changing the control mode with the controller during the 3 inertia mode or low response mode, stop the motor.</p> </td> <td>0h</td> </tr> <tr> <td>__x_</td> <td rowspan="3">For manufacturer setting</td> <td>0h</td> </tr> <tr> <td>_x__</td> <td>0h</td> </tr> <tr> <td>x___</td> <td>0h</td> </tr> </tbody> </table> | Setting digit | Explanation | Initial value | ___x | <p>Vibration suppression mode selection 0: Standard mode 1: 3 inertia mode 2: Low response mode</p> <p>When two low resonance frequencies are generated, select "3 inertia mode (___ 1)". When the load to motor inertia ratio exceeds the recommended load to motor inertia ratio, select "Low response mode (___ 2)".</p> <p>When you select the standard mode or low response mode, "Vibration suppression control 2" is not available. When you select the 3 inertia mode, the feed forward gain is not available.</p> <p>Before changing the control mode with the controller during the 3 inertia mode or low response mode, stop the motor.</p> | 0h | __x_ | For manufacturer setting | 0h | _x__ | 0h | x___ | 0h | Refer to Name and function column. | Each axis |
| Setting digit | Explanation | Initial value | | | | | | | | | | | | | | | |
| ___x | <p>Vibration suppression mode selection 0: Standard mode 1: 3 inertia mode 2: Low response mode</p> <p>When two low resonance frequencies are generated, select "3 inertia mode (___ 1)". When the load to motor inertia ratio exceeds the recommended load to motor inertia ratio, select "Low response mode (___ 2)".</p> <p>When you select the standard mode or low response mode, "Vibration suppression control 2" is not available. When you select the 3 inertia mode, the feed forward gain is not available.</p> <p>Before changing the control mode with the controller during the 3 inertia mode or low response mode, stop the motor.</p> | 0h | | | | | | | | | | | | | | | |
| __x_ | For manufacturer setting | 0h | | | | | | | | | | | | | | | |
| _x__ | | 0h | | | | | | | | | | | | | | | |
| x___ | | 0h | | | | | | | | | | | | | | | |

17. APPLICATION OF FUNCTIONS

| No. | Symbol | Name and function | Initial value [unit] | Setting range | Each/common | | | | | | | | | | | | | | | |
|---------------|---------------------------------------------------------------------------------------------------------------------------------------------------------------------------------------------------------------------------------------------------------------------------------------------------------------------------|------------------------------------------------------------------------------------------------------------------------------------------------------------------------------------------------------------------------------------------------------------------------------------------------------------------------------------------------------------------------------------------------------------------------------------------------------------------------------------------------------------------------------------------------------------------------------------------------------------------------------------------------------------------------------------------------------------------------------------------------------------------------------------------------------------------------------------------------------------------------------------------------------------------------------------------------|----------------------|---------------|---------------|--------|--------------------------|----|--------|---------------------------------------------------------------------------------------------------------------------------------------------------------------------------------------------------------------------------------------------------------------------------------------------------------------------------|----|---------|--------------------------|----|---------|--|----|------------------------------------|--|-----------|
| PX03 | VRFTX | <p>Vibration suppression control tuning mode (advanced vibration suppression control II)</p> <p>This is used to set the vibration suppression control tuning. Refer to (5) (C) in this section for details.</p> <table border="1"> <thead> <tr> <th>Setting digit</th> <th>Explanation</th> <th>Initial value</th> </tr> </thead> <tbody> <tr> <td>__ _ x</td> <td>For manufacturer setting</td> <td>0h</td> </tr> <tr> <td>__ x _</td> <td>Vibration suppression control 2 tuning mode selection Select the tuning mode of the vibration suppression control 2. To enable the digit, select "3 inertia mode (_ _ 1)" of "Vibration suppression mode selection" in [Pr. PX02 Function selection X-1]. 0: Disabled 1: Automatic setting 2: Manual setting</td> <td>0h</td> </tr> <tr> <td>_ x _ _</td> <td>For manufacturer setting</td> <td>0h</td> </tr> <tr> <td>x _ _ _</td> <td></td> <td>0h</td> </tr> </tbody> </table> | Setting digit | Explanation | Initial value | __ _ x | For manufacturer setting | 0h | __ x _ | Vibration suppression control 2 tuning mode selection Select the tuning mode of the vibration suppression control 2. To enable the digit, select "3 inertia mode (_ _ 1)" of "Vibration suppression mode selection" in [Pr. PX02 Function selection X-1]. 0: Disabled 1: Automatic setting 2: Manual setting | 0h | _ x _ _ | For manufacturer setting | 0h | x _ _ _ | | 0h | Refer to Name and function column. | | Each axis |
| Setting digit | Explanation | Initial value | | | | | | | | | | | | | | | | | | |
| __ _ x | For manufacturer setting | 0h | | | | | | | | | | | | | | | | | | |
| __ x _ | Vibration suppression control 2 tuning mode selection Select the tuning mode of the vibration suppression control 2. To enable the digit, select "3 inertia mode (_ _ 1)" of "Vibration suppression mode selection" in [Pr. PX02 Function selection X-1]. 0: Disabled 1: Automatic setting 2: Manual setting | 0h | | | | | | | | | | | | | | | | | | |
| _ x _ _ | For manufacturer setting | 0h | | | | | | | | | | | | | | | | | | |
| x _ _ _ | | 0h | | | | | | | | | | | | | | | | | | |
| PX04 | VRF21 | <p>Vibration suppression control 2 - Vibration frequency</p> <p>Set the vibration frequency for vibration suppression control 2 to suppress low-frequency machine vibration.</p> <p>To enable the setting value, set "Vibration suppression mode selection" to "3 inertia mode (_ _ _ 1)" in [Pr. PX02].</p> <p>When "Vibration suppression control 2 tuning mode selection" is set to "Automatic setting (_ _ 1 _)" in [Pr. PX03], this parameter will be set automatically. When "Manual setting (_ _ 2 _)" is selected, the setting written to the parameter is used.</p> <p>The setting range of this parameter varies, depending on the value in [Pr. PB07]. If a value out of the range is set, the vibration suppression control will be disabled. Refer to section 17.1.9 (5) (2) for details.</p> | 100.0 [Hz] | 0.1 to 300.0 | Each axis | | | | | | | | | | | | | | | |
| PX05 | VRF22 | <p>Vibration suppression control 2 - Resonance frequency</p> <p>Set the resonance frequency for vibration suppression control 2 to suppress low-frequency machine vibration.</p> <p>To enable the setting value, set "Vibration suppression mode selection" to "3 inertia mode (_ _ _ 1)" in [Pr. PX02].</p> <p>When "Vibration suppression control 2 tuning mode selection" is set to "Automatic setting (_ _ 1 _)" in [Pr. PX03], this parameter will be set automatically. When "Manual setting (_ _ 2 _)" is selected, the setting written to the parameter is used.</p> <p>The setting range of this parameter varies, depending on the value in [Pr. PB07]. If a value out of the range is set, the vibration suppression control will be disabled. Refer to section 17.1.9 (5) (2) for details.</p> | 100.0 [Hz] | 0.1 to 300.0 | Each axis | | | | | | | | | | | | | | | |
| PX06 | VRF23 | <p>Vibration suppression control 2 - Vibration frequency damping</p> <p>Set a damping of the vibration frequency for vibration suppression control 2 to suppress low-frequency machine vibration.</p> <p>To enable the setting value, set "Vibration suppression mode selection" to "3 inertia mode (_ _ _ 1)" in [Pr. PX02].</p> <p>When "Vibration suppression control 2 tuning mode selection" is set to "Automatic setting (_ _ 1 _)" in [Pr. PX03], this parameter will be set automatically. When "Manual setting (_ _ 2 _)" is selected, the setting written to the parameter is used. Refer to section 17.1.9 (5) (2) for details.</p> | 0.00 | 0.00 to 0.30 | Each axis | | | | | | | | | | | | | | | |
| PX07 | VRF24 | <p>Vibration suppression control 2 - Resonance frequency damping</p> <p>Set a damping of the resonance frequency for vibration suppression control 2 to suppress low-frequency machine vibration.</p> <p>To enable the setting value, set "Vibration suppression mode selection" to "3 inertia mode (_ _ _ 1)" in [Pr. PX02].</p> <p>When "Vibration suppression control 2 tuning mode selection" is set to "Automatic setting (_ _ 1 _)" in [Pr. PX03], this parameter will be set automatically. When "Manual setting (_ _ 2 _)" is selected, the setting written to the parameter is used. Refer to section 17.1.9 (5) (2) for details.</p> | 0.00 | 0.00 to 0.30 | Each axis | | | | | | | | | | | | | | | |

17. APPLICATION OF FUNCTIONS

| No. | Symbol | Name and function | Initial value [unit] | Setting range | Each/common |
|------|--------|--------------------------------------------------------------------------------------------------------------------------------------------------------------------------------------------------------------------------------------------------------------------------------------------------------------------------------------------------------------------------------------------------------------------------------------------------------------------------------------------------------------------------------------------------------------------------------------------------------------------------------------------------------------------------------------------------------------------------------------------------------------------------------------------------------------------------------------------------------------------------------------------------------------------------------------------------------------------------------------------------------------------------------------------------------------------|----------------------|---------------|-------------|
| PX08 | VRF21B | <p>Vibration suppression control 2 - Vibration frequency after gain switching</p> <p>Set the vibration frequency for vibration suppression control 2 when the gain switching is enabled.</p> <p>When you set a value less than 0.1 Hz, the value will be the same as [Pr. PX04].</p> <p>To enable this, select "3 inertia mode (_ _ _ 1)" of "Vibration suppression mode selection" in [Pr. PX02].</p> <p>This parameter will be enabled only when the following conditions are fulfilled.</p> <ul style="list-style-type: none"> • "Gain adjustment mode selection" in [Pr. PA08] is "Manual mode (_ _ _ 3)". • "Vibration suppression control 2 tuning mode selection" in [Pr. PX03] is "Manual setting (_ _ 2 _)". • "Gain switching selection" in [Pr. PB26] is "Control command from controller is enabled (_ _ _ 1)". <p>When you set "0.0", the value will be the same as [Pr. PX04].</p> <p>Switching during driving may cause a shock. Be sure to switch them after the servo motor or linear servo motor stops.</p> | 0.0 [Hz] | 0.0 to 300.0 | Each axis |
| PX09 | VRF22B | <p>Vibration suppression control 2 - Resonance frequency after gain switching</p> <p>Set the resonance frequency for vibration suppression control 2 when the gain switching is enabled.</p> <p>When you set a value less than 0.1 Hz, the value will be the same as [Pr. PX05].</p> <p>To enable this, select "3 inertia mode (_ _ _ 1)" of "Vibration suppression mode selection" in [Pr. PX02].</p> <p>This parameter will be enabled only when the following conditions are fulfilled.</p> <ul style="list-style-type: none"> • "Gain adjustment mode selection" in [Pr. PA08] is "Manual mode (_ _ _ 3)". • "Vibration suppression control 2 tuning mode selection" in [Pr. PX03] is "Manual setting (_ _ 2 _)". • "Gain switching selection" in [Pr. PB26] is "Control command from controller is enabled (_ _ _ 1)". <p>When you set "0.0", the value will be the same as [Pr. PX05].</p> <p>Switching during driving may cause a shock. Be sure to switch them after the servo motor or linear servo motor stops.</p> | 0.0 [Hz] | 0.0 to 300.0 | Each axis |
| PX10 | VRF23B | <p>Vibration suppression control 2 - Vibration frequency damping after gain switching</p> <p>Set a damping of the vibration frequency for vibration suppression control 2 when the gain switching is enabled.</p> <p>To enable this, select "3 inertia mode (_ _ _ 1)" of "Vibration suppression mode selection" in [Pr. PX02].</p> <p>This parameter will be enabled only when the following conditions are fulfilled.</p> <ul style="list-style-type: none"> • "Gain adjustment mode selection" in [Pr. PA08] is "Manual mode (_ _ _ 3)". • "Vibration suppression control 2 tuning mode selection" in [Pr. PX03] is "Manual setting (_ _ 2 _)". • "Gain switching selection" in [Pr. PB26] is "Control command from controller is enabled (_ _ _ 1)". <p>Switching during driving may cause a shock. Be sure to switch them after the servo motor or linear servo motor stops.</p> | 0.00 | 0.00 to 0.30 | Each axis |
| PX11 | VRF24B | <p>Vibration suppression control 2 - Resonance frequency damping after gain switching</p> <p>Set a damping of the resonance frequency for vibration suppression control 2 when the gain switching is enabled.</p> <p>To enable this, select "3 inertia mode (_ _ _ 1)" of "Vibration suppression mode selection" in [Pr. PX02].</p> <p>This parameter will be enabled only when the following conditions are fulfilled.</p> <ul style="list-style-type: none"> • "Gain adjustment mode selection" in [Pr. PA08] is "Manual mode (_ _ _ 3)". • "Vibration suppression control 2 tuning mode selection" in [Pr. PX03] is "Manual setting (_ _ 2 _)". • "Gain switching selection" in [Pr. PB26] is "Control command from controller is enabled (_ _ _ 1)". <p>Switching during driving may cause a shock. Be sure to switch them after the servo motor or linear servo motor stops.</p> | 0.00 | 0.00 to 0.30 | Each axis |

17. APPLICATION OF FUNCTIONS

| No. | Symbol | Name and function | Initial value [unit] | Setting range | Each/common | | | | | | | | | | | | | | | |
|---------------|----------------------------------------------------------------------------------------------------------------------------------------------------------------------------|-------------------------------------------------------------------------------------------------------------------------------------------------------------------------------------------------------------------------------------------------------------------------------------------------------------------------------------------------------------------------------------------------------------------------------------------------------------------------------------------------------------------------------------------------------------------------------------------------------------------------------------------------------------------------------------------------------------------------------------------------------------------------------------------------------------------------------------------------------------------------------------------------------------------------------------------------------------|----------------------|---------------|---------------|-------|----------------------------------------------------------------------------------------------------------------------------------------------------------------------------|----|--------|------------------------------------------------------------------------------------------------|----|---------|----------------------------------------------------------------------------------------------------------------------------------------------------------------------|---------|---------|------------------------------------|----|------------------------------------|--|-----------|
| PX12 | PG1B | <p>Model loop gain after gain switching</p> <p>Set the model loop gain when the gain switching is enabled.</p> <p>When you set a value less than 1.0 rad/s, the value will be the same as [Pr. PB07].</p> <p>This parameter will be enabled only when the following conditions are fulfilled.</p> <ul style="list-style-type: none"> • "Gain adjustment mode selection" in [Pr. PA08] is "Manual mode (_ _ _ 3)". • "Gain switching selection" in [Pr. PB26] is "Control command from controller is enabled (_ _ _ 1)". <p>Switching during driving may cause a shock. Be sure to switch them after the servo motor or linear servo motor stops.</p> | 0.0 [rad/s] | 0.0 to 2000.0 | Each axis | | | | | | | | | | | | | | | |
| PX13 | *XOP2 | <p>Function selection X-2</p> <table border="1" style="width: 100%; border-collapse: collapse;"> <thead> <tr> <th style="width: 15%;">Setting digit</th> <th style="width: 65%;">Explanation</th> <th style="width: 20%;">Initial value</th> </tr> </thead> <tbody> <tr> <td>___ x</td> <td> <p>One-touch tuning function selection</p> <p>0: Disabled</p> <p>1: Enabled</p> <p>When the digit is "0", the one-touch tuning with MR Configurator2 will be disabled.</p> </td> <td>1h</td> </tr> <tr> <td>__ x _</td> <td rowspan="3">For manufacturer setting</td> <td>0h</td> </tr> <tr> <td>_ x _ _</td> <td>0h</td> </tr> <tr> <td>x _ _ _</td> <td>0h</td> </tr> </tbody> </table> | Setting digit | Explanation | Initial value | ___ x | <p>One-touch tuning function selection</p> <p>0: Disabled</p> <p>1: Enabled</p> <p>When the digit is "0", the one-touch tuning with MR Configurator2 will be disabled.</p> | 1h | __ x _ | For manufacturer setting | 0h | _ x _ _ | 0h | x _ _ _ | 0h | Refer to Name and function column. | | Each axis | | |
| Setting digit | Explanation | Initial value | | | | | | | | | | | | | | | | | | |
| ___ x | <p>One-touch tuning function selection</p> <p>0: Disabled</p> <p>1: Enabled</p> <p>When the digit is "0", the one-touch tuning with MR Configurator2 will be disabled.</p> | 1h | | | | | | | | | | | | | | | | | | |
| __ x _ | For manufacturer setting | 0h | | | | | | | | | | | | | | | | | | |
| _ x _ _ | | 0h | | | | | | | | | | | | | | | | | | |
| x _ _ _ | | 0h | | | | | | | | | | | | | | | | | | |
| PX14 | OTHOV | <p>One-touch tuning - Overshoot permissible level</p> <p>Set a permissible value of overshoot amount for one-touch tuning as a percentage of the in-position range.</p> <p>However, setting "0" will be 50%.</p> | 0 [%] | 0 to 100 | Each axis | | | | | | | | | | | | | | | |
| PX17 | NH3 | <p>Machine resonance suppression filter 3</p> <p>Set the notch frequency of the machine resonance suppression filter 3.</p> <p>To enable the setting value, select "Enabled (_ _ _ 1)" of "Machine resonance suppression filter 3 selection" in [Pr. PX18].</p> | 4500 [Hz] | 10 to 4500 | Each axis | | | | | | | | | | | | | | | |
| PX18 | NHQ3 | <p>Notch shape selection 3</p> <p>Set the shape of the machine resonance suppression filter 3.</p> <table border="1" style="width: 100%; border-collapse: collapse;"> <thead> <tr> <th style="width: 15%;">Setting digit</th> <th style="width: 65%;">Explanation</th> <th style="width: 20%;">Initial value</th> </tr> </thead> <tbody> <tr> <td>___ x</td> <td> <p>Machine resonance suppression filter 3 selection</p> <p>0: Disabled</p> <p>1: Enabled</p> </td> <td>0h</td> </tr> <tr> <td>__ x _</td> <td> <p>Notch depth selection</p> <p>0: -40 dB</p> <p>1: -14 dB</p> <p>2: -8 dB</p> <p>3: -4 dB</p> </td> <td>0h</td> </tr> <tr> <td>_ x _ _</td> <td> <p>Notch width selection</p> <p>0: $\alpha = 2$</p> <p>1: $\alpha = 3$</p> <p>2: $\alpha = 4$</p> <p>3: $\alpha = 5$</p> </td> <td>0h</td> </tr> <tr> <td>x _ _ _</td> <td>For manufacturer setting</td> <td>0h</td> </tr> </tbody> </table> | Setting digit | Explanation | Initial value | ___ x | <p>Machine resonance suppression filter 3 selection</p> <p>0: Disabled</p> <p>1: Enabled</p> | 0h | __ x _ | <p>Notch depth selection</p> <p>0: -40 dB</p> <p>1: -14 dB</p> <p>2: -8 dB</p> <p>3: -4 dB</p> | 0h | _ x _ _ | <p>Notch width selection</p> <p>0: $\alpha = 2$</p> <p>1: $\alpha = 3$</p> <p>2: $\alpha = 4$</p> <p>3: $\alpha = 5$</p> | 0h | x _ _ _ | For manufacturer setting | 0h | Refer to Name and function column. | | Each axis |
| Setting digit | Explanation | Initial value | | | | | | | | | | | | | | | | | | |
| ___ x | <p>Machine resonance suppression filter 3 selection</p> <p>0: Disabled</p> <p>1: Enabled</p> | 0h | | | | | | | | | | | | | | | | | | |
| __ x _ | <p>Notch depth selection</p> <p>0: -40 dB</p> <p>1: -14 dB</p> <p>2: -8 dB</p> <p>3: -4 dB</p> | 0h | | | | | | | | | | | | | | | | | | |
| _ x _ _ | <p>Notch width selection</p> <p>0: $\alpha = 2$</p> <p>1: $\alpha = 3$</p> <p>2: $\alpha = 4$</p> <p>3: $\alpha = 5$</p> | 0h | | | | | | | | | | | | | | | | | | |
| x _ _ _ | For manufacturer setting | 0h | | | | | | | | | | | | | | | | | | |

17. APPLICATION OF FUNCTIONS

| No. | Symbol | Name and function | Initial value [unit] | Setting range | Each/ common | | | | | | | | | | | | | | |
|---------------|-------------------------------------------------------------------------------------------------------------------------------------------------------------------------------------------|--------------------------------------------------------------------------------------------------------------------------------------------------------------------------------------------------------------------------------------------------------------------------------------------------------------------------------------------------------------------------------------------------------------------------------------------------------------------------------------------------------------------------------------------------------------------------------------------------------------------------------------------------------------------------------------------------------------------------------------------------------------------------------------------------------------------------------------------------------------------------------------------------------------------------------------------------------------|----------------------|---------------|---------------|-------|-------------------------------------------------------------------------------------------------------------------------------------------------------------------------------------------|----|--------|-------------------------------------------------------------------------|----|---------|---------------------------------------------------------------------------------------------------|----|---------|--------------------------|----|------------------------------------|-----------|
| PX19 | NH4 | Machine resonance suppression filter 4 Set the notch frequency of the machine resonance suppression filter 4. To enable the setting value, select "Enabled (___ 1)" of "Machine resonance suppression filter 4 selection" in [Pr. PX20]. | 4500 [Hz] | 10 to 4500 | Each axis | | | | | | | | | | | | | | |
| PX20 | NHQ4 | Notch shape selection 4 Set the shape of the machine resonance suppression filter 4. <table border="1" data-bbox="347 517 1131 1055"> <thead> <tr> <th>Setting digit</th> <th>Explanation</th> <th>Initial value</th> </tr> </thead> <tbody> <tr> <td>___ x</td> <td>Machine resonance suppression filter 4 selection 0: Disabled 1: Enabled When you select "Enabled" of this digit, [Pr. PB17 Shaft resonance suppression filter] is not available.</td> <td>0h</td> </tr> <tr> <td>__ x _</td> <td>Notch depth selection 0: -40 dB 1: -14 dB 2: -8 dB 3: -4 dB</td> <td>0h</td> </tr> <tr> <td>_ x _ _</td> <td>Notch width selection 0: $\alpha = 2$ 1: $\alpha = 3$ 2: $\alpha = 4$ 3: $\alpha = 5$</td> <td>0h</td> </tr> <tr> <td>x _ _ _</td> <td>For manufacturer setting</td> <td>0h</td> </tr> </tbody> </table> | Setting digit | Explanation | Initial value | ___ x | Machine resonance suppression filter 4 selection 0: Disabled 1: Enabled When you select "Enabled" of this digit, [Pr. PB17 Shaft resonance suppression filter] is not available. | 0h | __ x _ | Notch depth selection 0: -40 dB 1: -14 dB 2: -8 dB 3: -4 dB | 0h | _ x _ _ | Notch width selection 0: $\alpha = 2$ 1: $\alpha = 3$ 2: $\alpha = 4$ 3: $\alpha = 5$ | 0h | x _ _ _ | For manufacturer setting | 0h | Refer to Name and function column. | Each axis |
| Setting digit | Explanation | Initial value | | | | | | | | | | | | | | | | | |
| ___ x | Machine resonance suppression filter 4 selection 0: Disabled 1: Enabled When you select "Enabled" of this digit, [Pr. PB17 Shaft resonance suppression filter] is not available. | 0h | | | | | | | | | | | | | | | | | |
| __ x _ | Notch depth selection 0: -40 dB 1: -14 dB 2: -8 dB 3: -4 dB | 0h | | | | | | | | | | | | | | | | | |
| _ x _ _ | Notch width selection 0: $\alpha = 2$ 1: $\alpha = 3$ 2: $\alpha = 4$ 3: $\alpha = 5$ | 0h | | | | | | | | | | | | | | | | | |
| x _ _ _ | For manufacturer setting | 0h | | | | | | | | | | | | | | | | | |
| PX21 | NH5 | Machine resonance suppression filter 5 Set the notch frequency of the machine resonance suppression filter 5. To enable the setting value, select "Enabled (___ 1)" of "Machine resonance suppression filter 5 selection" in [Pr. PX22]. | 4500 [Hz] | 10 to 4500 | Each axis | | | | | | | | | | | | | | |
| PX22 | NHQ5 | Notch shape selection 5 Set the shape of the machine resonance suppression filter 5. When you select "Enabled (___ 1)" of "Robust filter selection" in [Pr. PX31], the machine resonance suppression filter 5 is not available. <table border="1" data-bbox="347 1341 1131 1823"> <thead> <tr> <th>Setting digit</th> <th>Explanation</th> <th>Initial value</th> </tr> </thead> <tbody> <tr> <td>___ x</td> <td>Machine resonance suppression filter 5 selection 0: Disabled 1: Enabled</td> <td>0h</td> </tr> <tr> <td>__ x _</td> <td>Notch depth selection 0: -40 dB 1: -14 dB 2: -8 dB 3: -4 dB</td> <td>0h</td> </tr> <tr> <td>_ x _ _</td> <td>Notch width selection 0: $\alpha = 2$ 1: $\alpha = 3$ 2: $\alpha = 4$ 3: $\alpha = 5$</td> <td>0h</td> </tr> <tr> <td>x _ _ _</td> <td>For manufacturer setting</td> <td>0h</td> </tr> </tbody> </table> | Setting digit | Explanation | Initial value | ___ x | Machine resonance suppression filter 5 selection 0: Disabled 1: Enabled | 0h | __ x _ | Notch depth selection 0: -40 dB 1: -14 dB 2: -8 dB 3: -4 dB | 0h | _ x _ _ | Notch width selection 0: $\alpha = 2$ 1: $\alpha = 3$ 2: $\alpha = 4$ 3: $\alpha = 5$ | 0h | x _ _ _ | For manufacturer setting | 0h | Refer to Name and function column. | Each axis |
| Setting digit | Explanation | Initial value | | | | | | | | | | | | | | | | | |
| ___ x | Machine resonance suppression filter 5 selection 0: Disabled 1: Enabled | 0h | | | | | | | | | | | | | | | | | |
| __ x _ | Notch depth selection 0: -40 dB 1: -14 dB 2: -8 dB 3: -4 dB | 0h | | | | | | | | | | | | | | | | | |
| _ x _ _ | Notch width selection 0: $\alpha = 2$ 1: $\alpha = 3$ 2: $\alpha = 4$ 3: $\alpha = 5$ | 0h | | | | | | | | | | | | | | | | | |
| x _ _ _ | For manufacturer setting | 0h | | | | | | | | | | | | | | | | | |

17. APPLICATION OF FUNCTIONS

| No. | Symbol | Name and function | Initial value [unit] | Setting range | Each/common | | | | | | | | | | | | | | |
|---------------|------------------------------------------------------------------------------------------------------------------------------------------------------------------------------------------------------------------------------------------------------------------------------------------------------------------------------------------------------------------------------------------------------------------------------------------------------------------------------------------------------------------------------------|----------------------------------------------------------------------------------------------------------------------------------------------------------------------------------------------------------------------------------------------------------------------------------------------------------------------------------------------------------------------------------------------------------------------------------------------------------------------------------------------------------------------------------------------------------------------------------------------------------------------------------------------------------------------------------------------------------------------------------------------------------------------------------------------------------------------------------------------------------------------------------------------------------------------------------------------------------------------------------------------------------------------------------------------------------------------------------------------------------------------------------------------------------------------------------------------------------------------------------------------------------------------------------------------------------------------------------------------------------------------------------------------------------------------------------------------------------------------------------------------------------------------------------------------------------------------------------------------------------------------------------------------------------------------------------------------------------------------------------------------------------------------------------------------------------------------------------------------------------------------------------------------------------------------------------------------------------------------------------------------------------------------------------------------------------------------------------------------------|-------------------------|------------------------|---------------|--------|--------------------------|----|--------|------------------------------------------------------------------------------------------------------------------------------------------------------------------------------------------------------------------------------------------------------------------------------------------------------------------------------------------------------------------------------------------------------------|----|---------|------------------------------------------------------------------------------------------------------------------------------------------------------------------------------------------------------------------------------------------------------------------------------------------------------------------------------------------------------------------------------------------------------------------------------------------------------------------------------------------------------------------------------------|----|---------|--------------------------|----|------------------------------------|-----------|
| PX24 | FRIC | <p>Machine diagnosis function - Friction judgment speed</p> <p>Set a (linear) servo motor speed that divides a friction estimation area into high and low during the friction estimation process of the machine diagnosis.</p> <p>Setting "0" will set a value half of the rated speed.</p> <p>When your operation pattern is under the rated speed, we recommend that you set a half value of the maximum speed.</p> | 0 [r/min]/ [mm/s] | 0 to permissible speed | Each axis | | | | | | | | | | | | | | |
| PX25 | *TDS | <p>Tough drive setting</p> <p>Alarms may not be avoided with the tough drive function depending on the situations of the power supply and load fluctuation.</p> <p>You can assign MTTR (During tough drive) to pins CN3-9, CN3-13, and CN3-15 with [Pr. PD07] to [Pr. PD09].</p> <p>For MR-J4W2-0303B6 servo amplifiers, MTTR (during tough drive) cannot be assigned.</p> <table border="1" style="width: 100%; border-collapse: collapse;"> <thead> <tr> <th style="width: 15%;">Setting digit</th> <th style="width: 60%;">Explanation</th> <th style="width: 25%;">Initial value</th> </tr> </thead> <tbody> <tr> <td>__ _ x</td> <td>For manufacturer setting</td> <td>0h</td> </tr> <tr> <td>__ x _</td> <td> Vibration tough drive selection 0: Disabled 1: Enabled Selecting "1" enables to suppress vibrations by automatically changing setting values of [Pr. PB13 Machine resonance suppression filter 1] and [Pr. PB15 Machine resonance suppression filter 2] in case that the vibration exceeds the value of the oscillation level set in [Pr. PX26]. Refer to (8) in this section for details. </td> <td>0h</td> </tr> <tr> <td>_ x _ _</td> <td> SEMI-F47 function selection 0: Disabled 1: Enabled Selecting "1" enables to avoid triggering [AL. 10 Undervoltage] using the electrical energy charged in the capacitor in case that an instantaneous power failure occurs during operation. In [Pr. PX28 SEMI-F47 function - Instantaneous power failure detection time], set the time until the occurrence of [AL. 10.1 Voltage drop in the control circuit power]. For MR-J4W2-0303B6 servo amplifiers, this digit cannot be used other than the initial value. </td> <td>0h</td> </tr> <tr> <td>x _ _ _</td> <td>For manufacturer setting</td> <td>0h</td> </tr> </tbody> </table> | Setting digit | Explanation | Initial value | __ _ x | For manufacturer setting | 0h | __ x _ | Vibration tough drive selection 0: Disabled 1: Enabled Selecting "1" enables to suppress vibrations by automatically changing setting values of [Pr. PB13 Machine resonance suppression filter 1] and [Pr. PB15 Machine resonance suppression filter 2] in case that the vibration exceeds the value of the oscillation level set in [Pr. PX26]. Refer to (8) in this section for details. | 0h | _ x _ _ | SEMI-F47 function selection 0: Disabled 1: Enabled Selecting "1" enables to avoid triggering [AL. 10 Undervoltage] using the electrical energy charged in the capacitor in case that an instantaneous power failure occurs during operation. In [Pr. PX28 SEMI-F47 function - Instantaneous power failure detection time], set the time until the occurrence of [AL. 10.1 Voltage drop in the control circuit power]. For MR-J4W2-0303B6 servo amplifiers, this digit cannot be used other than the initial value. | 0h | x _ _ _ | For manufacturer setting | 0h | Refer to Name and function column. | Each axis |
| Setting digit | Explanation | Initial value | | | | | | | | | | | | | | | | | |
| __ _ x | For manufacturer setting | 0h | | | | | | | | | | | | | | | | | |
| __ x _ | Vibration tough drive selection 0: Disabled 1: Enabled Selecting "1" enables to suppress vibrations by automatically changing setting values of [Pr. PB13 Machine resonance suppression filter 1] and [Pr. PB15 Machine resonance suppression filter 2] in case that the vibration exceeds the value of the oscillation level set in [Pr. PX26]. Refer to (8) in this section for details. | 0h | | | | | | | | | | | | | | | | | |
| _ x _ _ | SEMI-F47 function selection 0: Disabled 1: Enabled Selecting "1" enables to avoid triggering [AL. 10 Undervoltage] using the electrical energy charged in the capacitor in case that an instantaneous power failure occurs during operation. In [Pr. PX28 SEMI-F47 function - Instantaneous power failure detection time], set the time until the occurrence of [AL. 10.1 Voltage drop in the control circuit power]. For MR-J4W2-0303B6 servo amplifiers, this digit cannot be used other than the initial value. | 0h | | | | | | | | | | | | | | | | | |
| x _ _ _ | For manufacturer setting | 0h | | | | | | | | | | | | | | | | | |

17. APPLICATION OF FUNCTIONS

| No. | Symbol | Name and function | Initial value [unit] | Setting range | Each/ common | | | | | | | | | | | | |
|---------------|------------------------------------------------------------------------------------------------------------------------------------------------------------------------------------------------------------------------------------------------------------------------------------------------------------------------------------------------------------------------------------------------------------------------------------------------------------------|----------------------------------------------------------------------------------------------------------------------------------------------------------------------------------------------------------------------------------------------------------------------------------------------------------------------------------------------------------------------------------------------------------------------------------------------------------------------------------------------------------------------------------------------------------------------------------------------------------------------------------------------------------------------------------------------------------------------------------------------------------------------------------------------------------------------------------------------------------------------------------------------------------------------------------------------------------------------------------------------------------------------------------------------------------------------------------------------------------------------------------------------------------------------------------------------------------------------------------|----------------------|---------------|---------------|---------|------------------------------------------------------------------------------------------------------------------------------------------------------------------------------------------------------------------------------------------------------------------------------------------------------------------------------------------------------------------------------------------------------------------------------------------------------------------|-----|---------|-------------------------------------------------------------------------------------------------------------------------------------------------------------------------------------------------------------------|-----|------------------------------------|--------|---------|----|------------------------------------|-----------|
| PX26 | OSCL1 | Vibration tough drive - Oscillation detection level Set a filter readjustment sensitivity of [Pr. PB13 Machine resonance suppression filter 1] and [Pr. PB15 Machine resonance suppression filter 2] while the vibration tough drive is enabled. However, setting "0" will be 50%. Example: When you set "50" to the parameter, the filter will be readjusted at the time of 50% or more oscillation level. | 50 [%] | 0 to 100 | Each axis | | | | | | | | | | | | |
| PX27 | *OSCL2 | Vibration tough drive function selection <table border="1" style="width: 100%; border-collapse: collapse;"> <thead> <tr> <th style="width: 15%;">Setting digit</th> <th style="width: 65%;">Explanation</th> <th style="width: 20%;">Initial value</th> </tr> </thead> <tbody> <tr> <td style="text-align: center;">_ _ _ x</td> <td>Oscillation detection alarm selection 0: [AL. 54 Oscillation detection] will occur at oscillation detection. 1: [AL. F3.1 Oscillation detection warning] will occur at oscillation detection. 2: Oscillation detection function disabled Select alarm or warning when an oscillation continues at a filter readjustment sensitivity level of [Pr. PX26]. The digit is continuously enabled regardless of the vibration tough drive in [Pr. PX25].</td> <td style="text-align: center;">0h</td> </tr> <tr> <td style="text-align: center;">_ _ x _</td> <td rowspan="3">For manufacturer setting</td> <td style="text-align: center;">0h</td> </tr> <tr> <td style="text-align: center;">_ x _ _</td> <td style="text-align: center;">0h</td> </tr> <tr> <td style="text-align: center;">x _ _ _</td> <td style="text-align: center;">0h</td> </tr> </tbody> </table> | Setting digit | Explanation | Initial value | _ _ _ x | Oscillation detection alarm selection 0: [AL. 54 Oscillation detection] will occur at oscillation detection. 1: [AL. F3.1 Oscillation detection warning] will occur at oscillation detection. 2: Oscillation detection function disabled Select alarm or warning when an oscillation continues at a filter readjustment sensitivity level of [Pr. PX26]. The digit is continuously enabled regardless of the vibration tough drive in [Pr. PX25]. | 0h | _ _ x _ | For manufacturer setting | 0h | _ x _ _ | 0h | x _ _ _ | 0h | Refer to Name and function column. | Each axis |
| Setting digit | Explanation | Initial value | | | | | | | | | | | | | | | |
| _ _ _ x | Oscillation detection alarm selection 0: [AL. 54 Oscillation detection] will occur at oscillation detection. 1: [AL. F3.1 Oscillation detection warning] will occur at oscillation detection. 2: Oscillation detection function disabled Select alarm or warning when an oscillation continues at a filter readjustment sensitivity level of [Pr. PX26]. The digit is continuously enabled regardless of the vibration tough drive in [Pr. PX25]. | 0h | | | | | | | | | | | | | | | |
| _ _ x _ | For manufacturer setting | 0h | | | | | | | | | | | | | | | |
| _ x _ _ | | 0h | | | | | | | | | | | | | | | |
| x _ _ _ | | 0h | | | | | | | | | | | | | | | |
| PX28 | CVAT | SEMI-F47 function - Instantaneous power failure detection time Set the time until the occurrence of [AL. 10.1 Voltage drop in the control circuit power]. This parameter setting range differs depending on the software version of the servo amplifier as follows. • Software version C0 or later: Setting range 30 ms to 200 ms • Software version C1 or earlier: Setting range 30 ms to 500 ms To comply with SEMI-F47 standard, it is unnecessary to change the initial value (200 ms). However, when the instantaneous power failure time exceeds 200 ms, and the instantaneous power failure voltage is less than 70% of the rated input voltage, the power may be normally turned off even if a value larger than 200 ms is set in the parameter. To disable the parameter, set "Disabled (_ 0 _ _)" of "SEMI-F47 function selection" in [Pr. PX25]. | 200 [ms] | 30 to 500 | Common | | | | | | | | | | | | |
| PX29 | DRAT | Drive recorder arbitrary alarm trigger setting <table border="1" style="width: 100%; border-collapse: collapse;"> <thead> <tr> <th style="width: 15%;">Setting digit</th> <th style="width: 65%;">Explanation</th> <th style="width: 20%;">Initial value</th> </tr> </thead> <tbody> <tr> <td style="text-align: center;">_ _ x x</td> <td>Alarm detail No. setting Set the digits when you execute the trigger with arbitrary alarm detail No. for the drive recorder function. When these digits are "0 0", only the arbitrary alarm No. setting will be enabled.</td> <td style="text-align: center;">00h</td> </tr> <tr> <td style="text-align: center;">x x _ _</td> <td>Alarm No. setting Set the digits when you execute the trigger with arbitrary alarm No. for the drive recorder function. When "0 0" are set, arbitrary alarm trigger of the drive recorder will be disabled.</td> <td style="text-align: center;">00h</td> </tr> </tbody> </table> <p>Setting example: To activate the drive recorder when [AL. 50 Overload 1] occurs, set "5 0 0 0". To activate the drive recorder when [AL. 50.3 Thermal overload error 4 during operation] occurs, set "5 0 0 3".</p> | Setting digit | Explanation | Initial value | _ _ x x | Alarm detail No. setting Set the digits when you execute the trigger with arbitrary alarm detail No. for the drive recorder function. When these digits are "0 0", only the arbitrary alarm No. setting will be enabled. | 00h | x x _ _ | Alarm No. setting Set the digits when you execute the trigger with arbitrary alarm No. for the drive recorder function. When "0 0" are set, arbitrary alarm trigger of the drive recorder will be disabled. | 00h | Refer to Name and function column. | Common | | | | |
| Setting digit | Explanation | Initial value | | | | | | | | | | | | | | | |
| _ _ x x | Alarm detail No. setting Set the digits when you execute the trigger with arbitrary alarm detail No. for the drive recorder function. When these digits are "0 0", only the arbitrary alarm No. setting will be enabled. | 00h | | | | | | | | | | | | | | | |
| x x _ _ | Alarm No. setting Set the digits when you execute the trigger with arbitrary alarm No. for the drive recorder function. When "0 0" are set, arbitrary alarm trigger of the drive recorder will be disabled. | 00h | | | | | | | | | | | | | | | |

17. APPLICATION OF FUNCTIONS

| No. | Symbol | Name and function | Initial value [unit] | Setting range | Each/common | | | | | | | | | | | | | |
|---------------|----------------------------------------------------------------------------------------------------------------------------------------------------------------------------------------------|---------------------------------------------------------------------------------------------------------------------------------------------------------------------------------------------------------------------------------------------------------------------------------------------------------------------------------------------------------------------------------------------------------------------------------------------------------------------------------------------------------------------------------------------------------------------------------------------------------------------------------------------------------------------------------------------------------------------------------------------------------------------------------------------------------------------------------------------------------------------------------------------------------------------------------------------------------------------------------------------------------------------------------------------------------------------------------------------------------------------------------------------------------------------------------------------------------------------------------------------------------------------------------------------------------------------------------------------------------------------------------------------------------------------------------------------------------------------------------------------------------------------------------------------------------|----------------------|------------------------------------|---------------|---------|----------------------------------------------------------------------------------------------------------------------------------------------------------------------------------------------|-----------------------------------------------------------------------|-------------|--------------------------|---------|-----------------------------------------------------------------------|-------------|-----------------------------------------------------------------------|-------|------------------------------------|--------|-----------|
| PX30 | DRT | <p>Drive recorder switching time setting Set the drive recorder switching time.</p> <p>When a USB communication is cut during using a graph function, the function will be changed to the drive recorder function after the setting time of this parameter.</p> <p>When a value from "1" to "32767" is set, it will switch after the setting value.</p> <p>However, when "0" is set, it will switch after 600 s.</p> <p>When "-1" is set, the drive recorder function is disabled.</p> | 0 [s] | -1 to 32767 | Common | | | | | | | | | | | | | |
| PX31 | XOP4 | <p>Function selection X-4</p> <table border="1" style="width: 100%; border-collapse: collapse;"> <thead> <tr> <th style="width: 15%;">Setting digit</th> <th style="width: 65%;">Explanation</th> <th style="width: 20%;">Initial value</th> </tr> </thead> <tbody> <tr> <td style="text-align: center;">_ _ _ x</td> <td> <p>Robust filter selection 0: Disabled 1: Enabled</p> <p>When you select "Enabled" of this digit, the machine resonance suppression filter 5 set in [Pr. PX22] is not available.</p> </td> <td style="text-align: center;">0h</td> </tr> <tr> <td style="text-align: center;">_ _ x _</td> <td rowspan="3" style="text-align: center;">For manufacturer setting</td> <td style="text-align: center;">0h</td> </tr> <tr> <td style="text-align: center;">_ x _ _</td> <td style="text-align: center;">0h</td> </tr> <tr> <td style="text-align: center;">x _ _ _</td> <td style="text-align: center;">0h</td> </tr> </tbody> </table> | Setting digit | Explanation | Initial value | _ _ _ x | <p>Robust filter selection 0: Disabled 1: Enabled</p> <p>When you select "Enabled" of this digit, the machine resonance suppression filter 5 set in [Pr. PX22] is not available.</p> | 0h | _ _ x _ | For manufacturer setting | 0h | _ x _ _ | 0h | x _ _ _ | 0h | Refer to Name and function column. | | Each axis |
| Setting digit | Explanation | Initial value | | | | | | | | | | | | | | | | |
| _ _ _ x | <p>Robust filter selection 0: Disabled 1: Enabled</p> <p>When you select "Enabled" of this digit, the machine resonance suppression filter 5 set in [Pr. PX22] is not available.</p> | 0h | | | | | | | | | | | | | | | | |
| _ _ x _ | For manufacturer setting | 0h | | | | | | | | | | | | | | | | |
| _ x _ _ | | 0h | | | | | | | | | | | | | | | | |
| x _ _ _ | | 0h | | | | | | | | | | | | | | | | |
| PX43 | **STOD | <p>STO diagnosis error detection time Set the time from when an error occurs in the STO input signal or STO circuit until the detection of [AL. 68.1 Mismatched STO signal error].</p> <p>When 0 s is set, the detection of [AL. 68.1 Mismatched STO signal error] is not performed.</p> <p>The following shows safety levels at the time of parameter setting.</p> <table border="1" style="width: 100%; border-collapse: collapse;"> <thead> <tr> <th style="width: 10%;">Setting value</th> <th style="width: 20%;">STO input diagnosis by TOFB output</th> <th style="width: 70%;">Safety level</th> </tr> </thead> <tbody> <tr> <td rowspan="2" style="text-align: center;">0</td> <td style="text-align: center;">Execute</td> <td rowspan="2" style="text-align: center;">EN ISO 13849-1 Category 3 PL d, IEC 61508 SIL 2, and EN 62061 SIL CL2</td> </tr> <tr> <td style="text-align: center;">Not execute</td> </tr> <tr> <td rowspan="2" style="text-align: center;">1 to 60</td> <td style="text-align: center;">Execute</td> <td style="text-align: center;">EN ISO 13849-1 Category 3 PL e, IEC 61508 SIL 3, and EN 62061 SIL CL3</td> </tr> <tr> <td style="text-align: center;">Not execute</td> <td style="text-align: center;">EN ISO 13849-1 Category 3 PL d, IEC 61508 SIL 2, and EN 62061 SIL CL2</td> </tr> </tbody> </table> <p>When the short-circuit connector is connected to the CN8 connector, set "0" in the parameter.</p> <p>This parameter is available with servo amplifiers with software version C1 or later.</p> | Setting value | STO input diagnosis by TOFB output | Safety level | 0 | Execute | EN ISO 13849-1 Category 3 PL d, IEC 61508 SIL 2, and EN 62061 SIL CL2 | Not execute | 1 to 60 | Execute | EN ISO 13849-1 Category 3 PL e, IEC 61508 SIL 3, and EN 62061 SIL CL3 | Not execute | EN ISO 13849-1 Category 3 PL d, IEC 61508 SIL 2, and EN 62061 SIL CL2 | 0 [s] | 0 to 60 | Common | |
| Setting value | STO input diagnosis by TOFB output | Safety level | | | | | | | | | | | | | | | | |
| 0 | Execute | EN ISO 13849-1 Category 3 PL d, IEC 61508 SIL 2, and EN 62061 SIL CL2 | | | | | | | | | | | | | | | | |
| | Not execute | | | | | | | | | | | | | | | | | |
| 1 to 60 | Execute | EN ISO 13849-1 Category 3 PL e, IEC 61508 SIL 3, and EN 62061 SIL CL3 | | | | | | | | | | | | | | | | |
| | Not execute | EN ISO 13849-1 Category 3 PL d, IEC 61508 SIL 2, and EN 62061 SIL CL2 | | | | | | | | | | | | | | | | |

17. APPLICATION OF FUNCTIONS

(4) One-touch tuning

| POINT |
|-----------------------------------------------------------------------------------------------------------------------------------------------------------------------------------------------------------------------------------------------------------------------------------------------------------------------------------------------------------------------------------------------------------------------------------------------------------------------------------------------------------------------------------------------------------------------------------------------------------------------------------------------------------------------------------------------------------------------------------------------------------------------------------------------------------------------------------------------------------------------------------------------------------------------------------------------------------------------------------------------------------------------------------------------------------------------------------------------------------------------------------------------------------------------------------------------------------------------------------------------------------------------------------------------------------------------------------------------------------------------------------------------------------------------------------------------------------------------------------------------------------------------------------------------------------------------------|
| <ul style="list-style-type: none"> ● After the one-touch tuning is completed, "Gain adjustment mode selection" in [Pr. PA08] will be set to "2 gain adjustment mode 2 (_ _ _ 4)". To estimate [Pr. PB06 Load to motor inertia ratio/load to motor mass ratio], set "Gain adjustment mode selection" in [Pr. PA08] to "Auto tuning mode 1 (_ _ _ 1)". ● When executing the one-touch tuning, check the [Pr. PX13 One-touch tuning function selection] is " _ _ _ 1" (initial value). ● At start of the one-touch tuning, only when "Auto tuning mode 1 (_ _ _ 1)" or "2 gain adjustment mode 1 (interpolation mode) (_ _ _ 0)" of "Gain adjustment mode selection" is selected in [Pr. PA08], [Pr. PB06 Load to motor inertia ratio/load to motor mass ratio] will be estimated. ● Execute the one-touch tuning while the servo system controller and the servo amplifier are connected. ● When executing the one-touch tuning in the test operation mode (SW2-1 is on), write the tuning result to servo parameters of the servo system controller, and then connect the servo system controller and the servo amplifier. ● The amplifier command method can be used with the servo amplifier with software version C1 or later and MR Configurator2 with software version 1.45X or later. ● When the one-touch tuning is executed, MR Configurator2 is required. ● For MR-J4W2-0303B6 servo amplifier, one-touch tuning by the amplifier command method will be available in the future. |

The one-touch tuning includes two methods: the user command method and the amplifier command method.

1) User command method

The user command method performs one-touch tuning by inputting commands from outside the servo amplifier.

2) Amplifier command method

In the amplifier command method, when you simply input a travel distance (permissible travel distance) that collision against the equipment does not occur during servo motor driving, a command for the optimum tuning will be generated inside the servo amplifier to perform one-touch tuning.

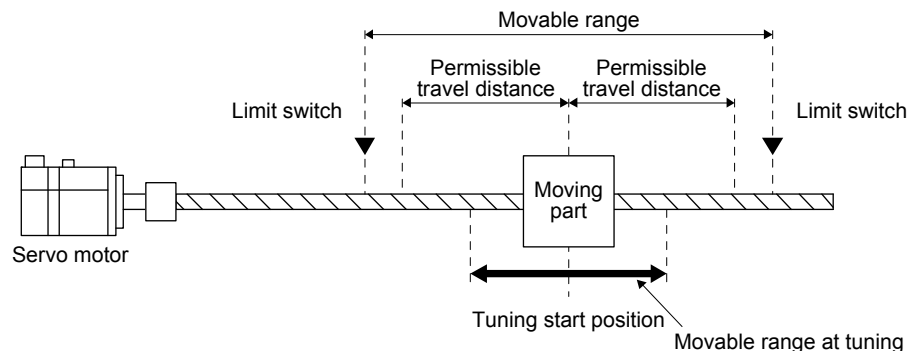

17. APPLICATION OF FUNCTIONS

The following parameters are set automatically with one-touch tuning. Also, "Gain adjustment mode selection" in [Pr. PA08] will be "2 gain adjustment mode 2 (_ _ _ 4)" automatically. Other parameters will be set to an optimum value depending on the setting of [Pr. PA09 Auto tuning response].

Table 17.5 List of parameters automatically set with one-touch tuning

| Parameter | Symbol | Name |
|-----------|--------|---------------------------------------------------------------------------------------|
| PA08 | ATU | Auto tuning mode |
| PA09 | RSP | Auto tuning response |
| PB01 | FILT | Adaptive tuning mode (adaptive filter II) |
| PB02 | VRFT | Vibration suppression control tuning mode (advanced vibration suppression control II) |
| PB06 | GD2 | Load to motor inertia ratio |
| PB07 | PG1 | Model loop gain |
| PB08 | PG2 | Position loop gain |
| PB09 | VG2 | Speed loop gain |
| PB10 | VIC | Speed integral compensation |
| PB12 | OVA | Overshoot amount compensation |
| PB13 | NH1 | Machine resonance suppression filter 1 |
| PB14 | NHQ1 | Notch shape selection 1 |
| PB15 | NH2 | Machine resonance suppression filter 2 |
| PB16 | NHQ2 | Notch shape selection 2 |
| PB17 | NHF | Shaft resonance suppression filter |

| Parameter | Symbol | Name |
|-----------|--------|---------------------------------------------------------------|
| PB18 | LPF | Low-pass filter setting |
| PB19 | VRF11 | Vibration suppression control 1 - Vibration frequency |
| PB20 | VRF12 | Vibration suppression control 1 - Resonance frequency |
| PB21 | VRF13 | Vibration suppression control 1 - Vibration frequency damping |
| PB22 | VRF14 | Vibration suppression control 1 - Resonance frequency damping |
| PB23 | VFBF | Low-pass filter selection |
| PX17 | NH3 | Machine resonance suppression filter 3 |
| PX18 | NHQ3 | Notch shape selection 3 |
| PX19 | NH4 | Machine resonance suppression filter 4 |
| PX20 | NHQ4 | Notch shape selection 4 |
| PX22 | NHQ5 | Notch shape selection 5 |
| PX31 | XOP4 | Function selection X-4 |

17. APPLICATION OF FUNCTIONS

(a) One-touch tuning flowchart

1) User command method

Make one-touch tuning as follows.

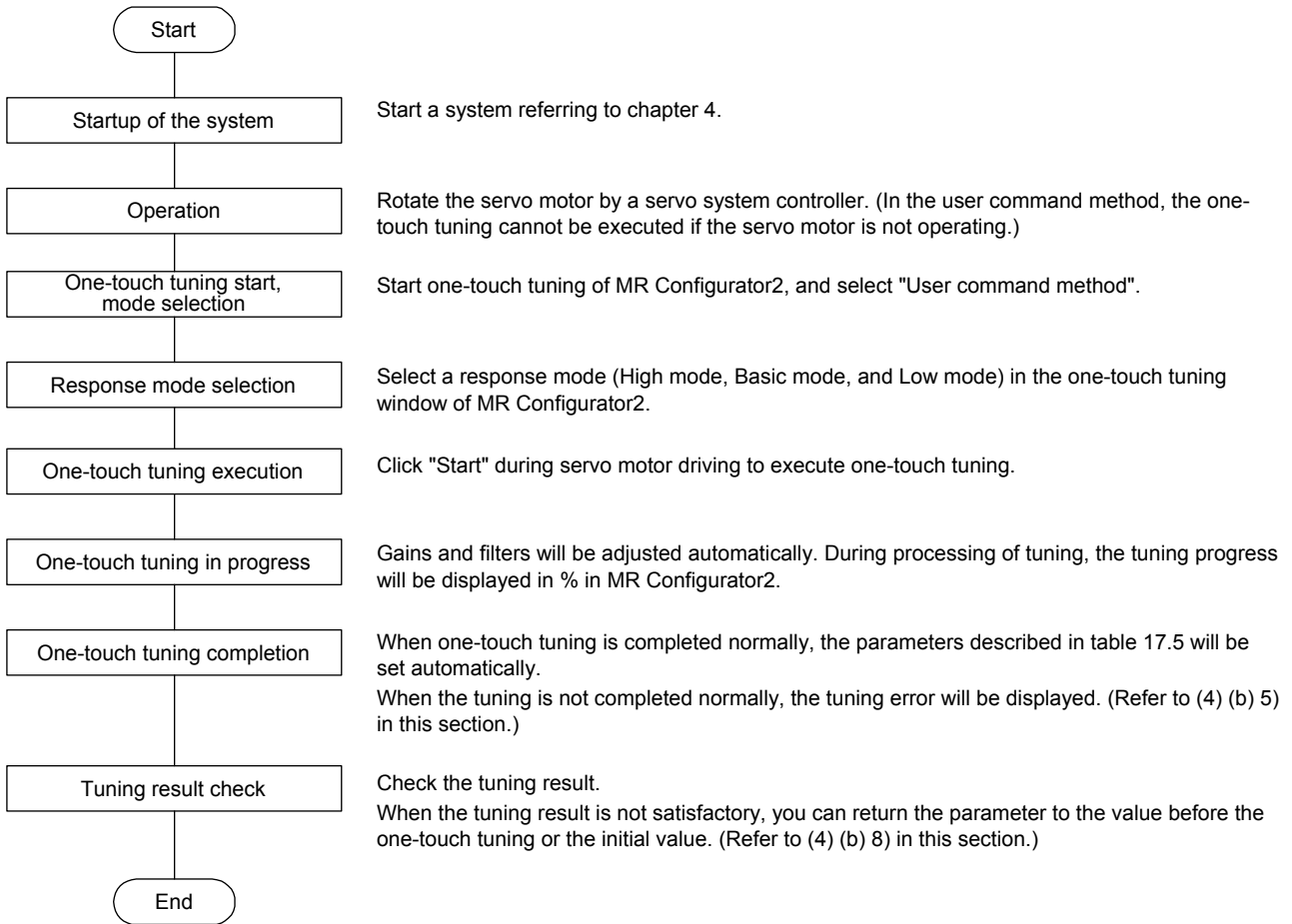

17. APPLICATION OF FUNCTIONS

2) Amplifier command method Make one-touch tuning as follows.

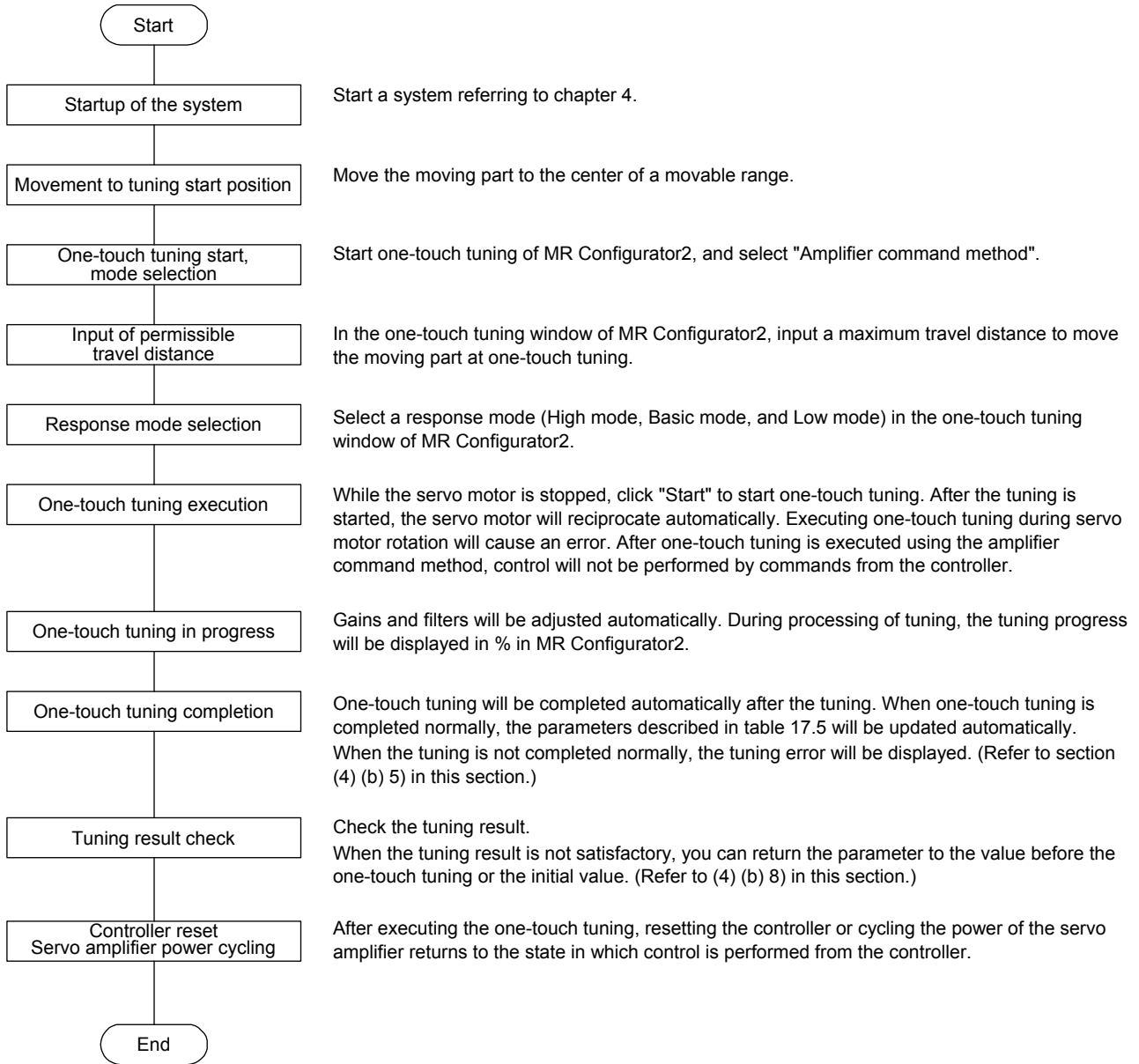

17. APPLICATION OF FUNCTIONS

(b) Display transition and operation procedure of one-touch tuning

1) Command method selection

Select a command method from two methods in the one-touch tuning window of MR Configurator2.

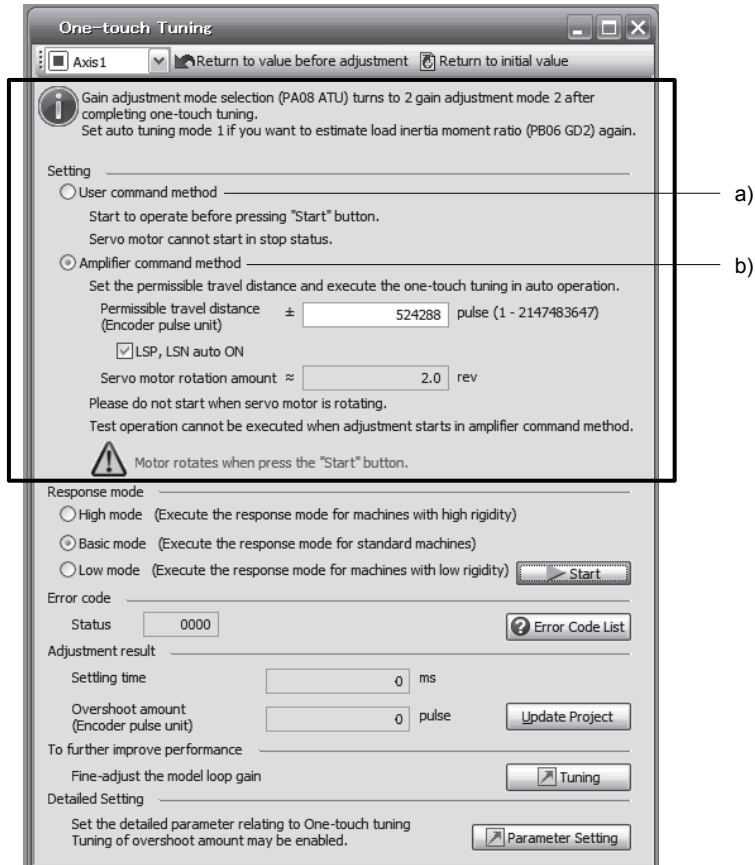

17. APPLICATION OF FUNCTIONS

a) User command method

It is recommended to input commands meeting the following conditions to the servo amplifier. If one-touch tuning is executed while commands which do not meet the conditions are inputted to the servo amplifier, the one-touch tuning error may occur.

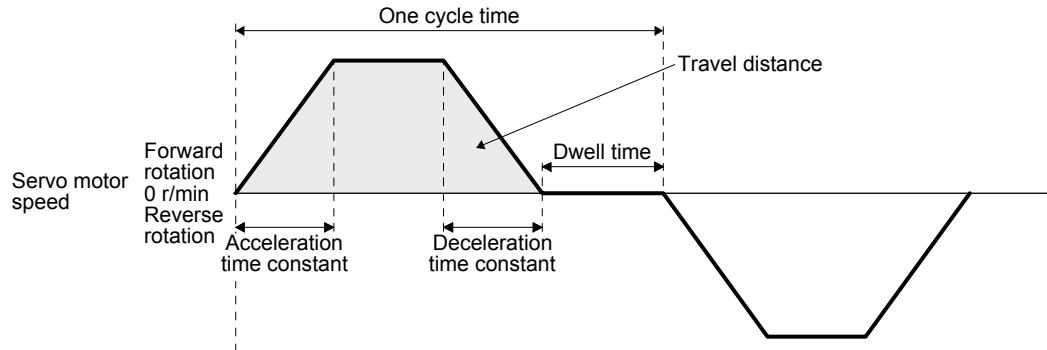

Fig. 17.1 Recommended command for one-touch tuning in the user command method

| Item | Description |
|----------------------------------------------------------|-----------------------------------------------------------------------------------------------------------------------------------------------------------------------------------------------------------------------------------------------------------------------------------------------------------------------------------------------------------------------------------------------------------------|
| Travel distance | Set 100 pulses or more in encoder unit. Setting less than 100 pulses will cause the one-touch tuning error "C004". |
| Servo motor speed | Set 150 r/min (mm/s) or higher. Setting less than 150 r/min (mm/s) may cause the one-touch tuning error "C005". |
| Acceleration time constant Deceleration time constant | Set the time to reach 2000 r/min (mm/s) to 5 s or less. Set an acceleration time constant/deceleration time constant so that the acceleration/deceleration torque is 10% or more of the rated torque. The estimation accuracy of the load to motor inertia ratio is more improved as the acceleration/deceleration torque is larger, and the one-touch tuning result will be closer to the optimum value. |
| Dwell time | Set 200 ms or more. Setting a smaller value may cause the one-touch tuning error "C004". |
| One cycle time | Set 30 s or less. Setting over 30 s will cause the one-touch tuning error "C004". |

17. APPLICATION OF FUNCTIONS

b) Amplifier command method

Input a permissible travel distance. Input it in the load-side resolution unit for the fully closed loop control mode, and in the servo motor-side resolution unit for other control modes. In the amplifier command method, the servo motor will be operated in a range between "current value \pm permissible travel distance". Input the permissible travel distance as large as possible within a range that the movable part does not collide against the machine. Inputting a small permissible travel distance decreases the possibility that the moving part will collide against the machine. However, the estimation accuracy of the load to motor inertia ratio may be lower, resulting in improper tuning.

Also, executing the one-touch tuning in the amplifier command method will generate a command for the following optimum tuning inside the servo amplifier to start the tuning.

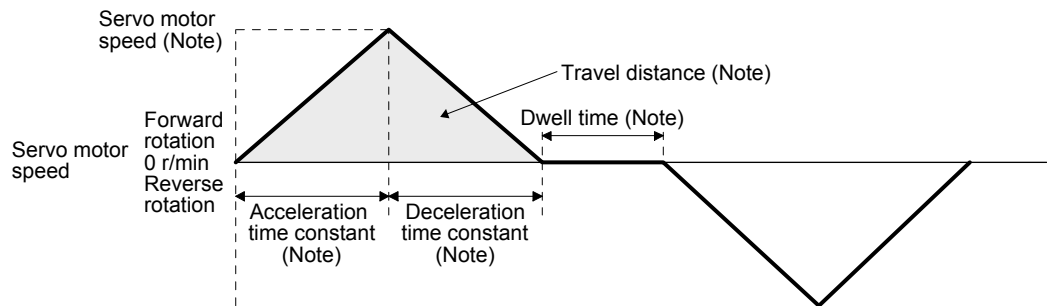

Note. It will be automatically generated in the servo amplifier.

Fig. 17.2 Command generated by one-touch tuning in the amplifier command method

| Item | Description |
|----------------------------------------------------------|---------------------------------------------------------------------------------------------------------------------------------------------------------------------------------------------------------------------------------|
| Travel distance | An optimum travel distance will be automatically set in the range not exceeding the user-inputted permissible travel distance with MR Configurator2. |
| Servo motor speed | A speed not exceeding 1/2 of the rated speed and overspeed alarm detection level ([Pr. PC08]) will be automatically set. |
| Acceleration time constant Deceleration time constant | An acceleration time constant/deceleration time constant will be automatically set so as not to exceed 60% of the rated torque and the torque limit value set at the start of one-touch tuning in the amplifier command method. |
| Dwell time | A dwell time in which the one-touch tuning error "C004" does not occur will be automatically set. |

17. APPLICATION OF FUNCTIONS

2) Response mode selection

Select a response mode from 3 modes in the one-touch tuning window of MR Configurator2.

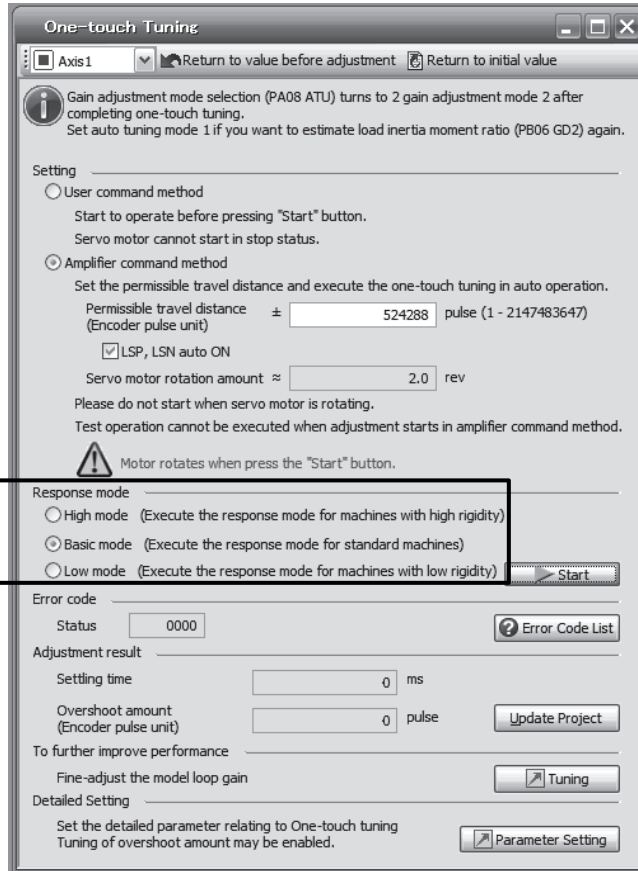

Table 17.6 Response mode explanations

| Response mode | Explanation |
|---------------|-------------------------------------|
| High mode | This mode is for high-rigid system. |
| Basic mode | This mode is for standard system. |
| Low mode | This mode is for low-rigid system. |

17. APPLICATION OF FUNCTIONS

Refer to the following table for selecting a response mode.

Table 17.7 Guideline for response mode

| Response mode | | | Response | Machine characteristic |
|---------------|------------|-----------|-----------------------------------------|------------------------------------|
| Low mode | Basic mode | High mode | | Guideline of corresponding machine |
| ↑ ↓ | ↑ ↓ | ↑ ↓ | Low response ↑ ↓ High response | |

3) One-touch tuning execution

| POINT |
|-----------------------------------------------------------------------------------------------------------------------------------------------------------------------------------------------------------------------------------------------------------------------------------------------------------------------------------------------------------------------------------------------------------------------------------------------------------------------------------------------------------------------------------------------------------------------------------------------------------------------------------------------------------------------------------------------------------------------------------------------------------------------------------------------------------------------------------------------------------------------------------------------------------------------------------------------------------------------------------------------------------------------------------------------------------------------------------------------------------------------------------------------------------------------------------|
| <ul style="list-style-type: none"> ● For equipment in which overshoot during one-touch tuning is in the permissible level of the in-position range, changing the value of [Pr. PX14 One-touch tuning overshoot permissible level] will shorten the settling time and improve the response. ● When executing one-touch tuning in the amplifier command method, turn on EM2. When you turn off EM2 during one-touch tuning, "C008" will be displayed at status in error code, and the one-touch tuning will be canceled. ● When executing the one-touch tuning in the amplifier command method, FLS (Upper stroke limit) and RLS (Lower stroke limit) will be disabled. Thus, set a permissible travel distance within a range where moving part collision never occurs, or execute the one-touch tuning in a state in which the servo motor can immediately stop in emergency. ● When one-touch tuning is executed in the amplifier command method while magnetic pole detection is not being performed, magnetic pole detection will be performed, and then one-touch tuning will start after the magnetic pole detection is completed. |

After the response mode is selected in (4) (b) 2) in this section, clicking "Start" will start one-touch tuning. If "Start" is clicked while the servo motor stops, "C002" or "C004" will be displayed at status in error code. (Refer to (4) (b) 5) in this section for error codes.)

17. APPLICATION OF FUNCTIONS

Click "Start" with the amplifier command method selected in the servo-off, the servo-on will be automatically enabled, and the one-touch tuning will start. In the one-touch tuning by the amplifier command method, an optimum tuning command will be generated in the servo amplifier after servo-on. Then, the servo motor will reciprocate, and the one-touch tuning will be executed. After the tuning is completed or canceled, the servo amplifier will be the servo-off status. When the servo-on command is inputted from outside, the amplifier will be the servo-on status.

After one-touch tuning is executed using the amplifier command method, control will not be performed by commands from the controller. To return to the state in which control is performed by commands from the controller, reset the controller or cycle the power.

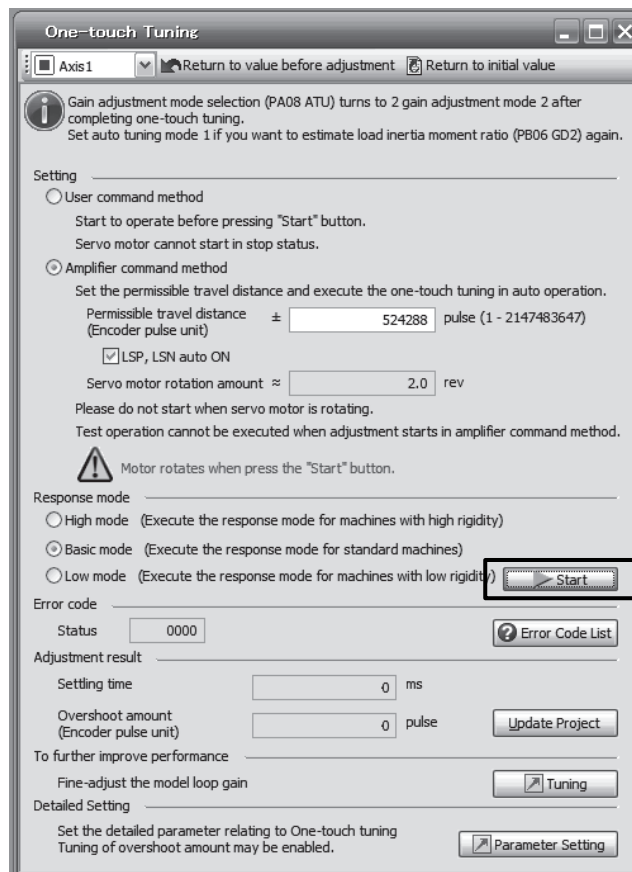

During processing of one-touch tuning, the progress will be displayed as follows. Tuning will be completed at 100%.

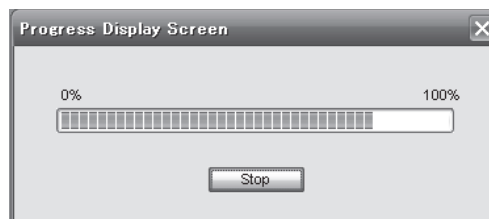

17. APPLICATION OF FUNCTIONS

Completing the one-touch tuning will start writing tuning parameters to the servo amplifier, and the following window will be displayed. Select whether or not to reflect the tuning result in the project.

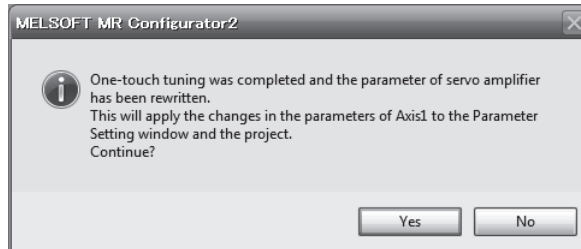

After the one-touch tuning is completed, "0000" will be displayed at status in error code. In addition, settling time and overshoot amount will be displayed in "Adjustment result".

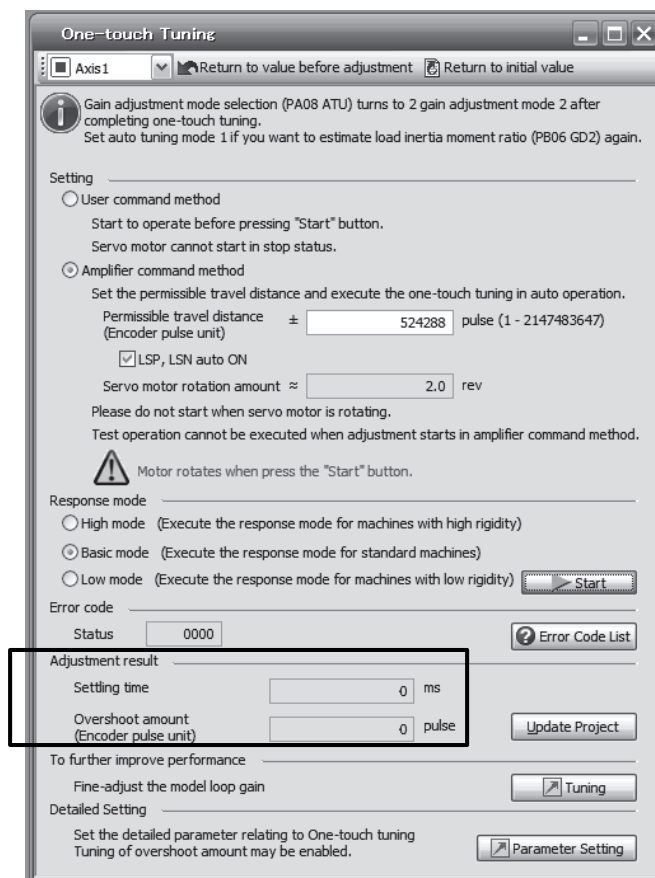

4) Stop of one-touch tuning

When "Stop" is clicked during one-touch tuning, the tuning will be stopped. At this time, "C000" will be displayed at status in error code. When the one-touch tuning is stopped, the parameter setting will be returned to the values at the start of the one-touch tuning. Stop the servo motor before executing the one-touch tuning again. In addition, execute it after the moving part is returned to the tuning start position.

17. APPLICATION OF FUNCTIONS

5) If an error occurs

If a tuning error occurs during tuning, one-touch tuning will be stopped. With that, the following error code will be displayed in status. Check the cause of tuning error. When executing one-touch tuning again, stop the servo motor once. In addition, after returning the moving part to the tuning start position, execute it.

| Display | Name | Error detail | Corrective action example |
|---------|------------------------------------------|------------------------------------------------------------------------------------------------------------------------------------------------------------------------------------------------------------------------------------------|-----------------------------------------------------------------------------------------------------------------------------------------------------------------------------------------------------------------------------------------------------------------------------------------------------------------------------------------------------------------------------------------------------------------------------------------------------------------------------------------------------------------------------------------------------------------------------------------------------------------------------------------------------------------------------------------------------------------------------------------------------------------------------------------------------------------------------------------------------------------------------------------------------------------------------------------------------------|
| C000 | Tuning canceled | "Stop" was clicked during one-touch tuning. | |
| C001 | Overshoot exceeded | Overshoot amount is a value larger than the one set in [Pr. PA10 In-position range] and [Pr. PX14 One-touch tuning - Overshoot permissible level]. | Increase the in-position range or overshoot permissible level. |
| C002 | Servo-off during tuning | The one-touch tuning was attempted in the user command method during servo-off. The servo amplifier will be servo-off status during one-touch tuning. | When executing one-touch tuning in the user command method, turn to servo-on, and then execute it. Prevent the servo amplifier from being the servo-off status during one-touch tuning. |
| C003 | Control mode error | 1. The one-touch tuning was attempted while the torque control mode was selected in the control modes. 2. During one-touch tuning, the control mode was attempted to change from the position control mode to the speed control mode. | Select the position control mode or speed control mode for the control mode from the controller, and then execute one-touch tuning. Do not change the control mode during the one-touch tuning. |
| C004 | Time-out | 1. One cycle time during the operation has been over 30 s. 2. The command speed is slow. 3. The operation interval of the continuous operation is short. | Set one cycle time during the operation (time from the command start to the next command start) to 30 s or less. Set the servo motor speed to 100 r/min or higher. Error is less likely to occur as the setting speed is higher. When one-touch tuning by the amplifier command is used, set a permissible travel distance so that the servo motor speed is 100 r/min or higher. Set a permissible travel distance to two or more revolutions as a guide value to set the servo motor speed to 100 r/min. Set the stop interval during operation to 200 ms or more. Error is less likely to occur as the setting time is longer. |
| C005 | Load to motor inertia ratio misestimated | 1. The estimation of the load to motor inertia ratio at one-touch tuning was a failure. 2. The load to motor inertia ratio was not estimated due to an oscillation or other influences. | Drive the motor with meeting conditions as follows. <ul style="list-style-type: none"> • The acceleration time constant/deceleration time constant to reach 2000 r/min (mm/s) is 5 s or less. • Speed is 150 r/min (mm/s) or higher. • The load to servo motor (mass of linear servo motor's primary side or direct drive motor) inertia ratio is 100 times or less. • The acceleration/deceleration torque is 10% or more of the rated torque. Set to the auto tuning mode that does not estimate the load to motor inertia ratio as follows, and then execute the one-touch tuning. <ul style="list-style-type: none"> • Select "Auto tuning mode 2 (_ _ _ 2)", "Manual mode (_ _ _ 3)", or "2 gain adjustment mode 2 (_ _ _ 4)" of "Gain adjustment mode selection" in [Pr. PA08]. • Manually set [Pr. PB06 Load to motor inertia ratio/load to motor mass ratio] properly. |

17. APPLICATION OF FUNCTIONS

| Display | Name | Error detail | Corrective action example |
|---------|------------------------------------|---------------------------------------------------------------------------------------------------------------------------------------------------------------------------------------------------------------------------------------------------------------------------------------------------------------------------------------------------|-------------------------------------------------------------------------------------------------------------------------------------------------------------------------------------------------------------------------------------------------------------------------------------------------------------------------------------------------------------------------------------------------------------------------------------------------------------------------------------------------------------------------------------------------------------------------------------------------------------------------------------------------------------------------------------------------------------------------------------------------------------------------------------------------------------------------------------------------------------------|
| C006 | Amplifier command start error | One-touch tuning was attempted to start in the amplifier command method under the following speed condition. Servo motor speed of one axis.: 20 r/min or higher | Execute the one-touch tuning in the amplifier command method while the servo motor is stopped. |
| C007 | Amplifier command generation error | 1. One-touch tuning was executed in the amplifier command method when the permissible travel distance is set to 100 pulses or less in the encoder pulse unit, or the distance is set not to increase the servo motor speed to 150 r/min (mm/s) (50 r/min for direct drive motor) or higher at the time of load to motor inertia ratio estimation. | Set a permissible travel distance to 100 pulses or more in the encoder pulse unit, or a distance so as to increase the servo motor speed to 150 r/min (mm/s) (50 r/min for direct drive motor) or higher at the time of load to motor inertia ratio estimation, and then execute the one-touch tuning. Set a permissible travel distance to four or more revolutions as a guide value. Load to motor inertia ratio will be estimated when "0000" or "0001" is set in [Pr. PA08 Auto tuning mode] at the start of one-touch tuning. If the permissible travel distance is short and the servo motor speed cannot be increased to 150 r/min (mm/s) (50 r/min for direct drive motor) or higher, select "Auto tuning mode 2 (_ _ _ 2)", "Manual mode (_ _ _ 3)", or "2 gain adjustment mode 2 (_ _ _ 4)" of "Gain adjustment mode selection" in [Pr. PA08]. |
| | | 2. An overspeed alarm detection level is set so that the servo motor speed becomes 150 r/min (mm/s) (50 r/min for direct drive motor) or less at the time of load to motor inertia ratio estimation. | When estimating the load to motor inertia ratio, set the overspeed alarm detection level so that the speed becomes 150 r/min or more. |
| | | 3. The torque limit has been set to 0. | Set the torque limit value to greater than 0. |
| C008 | Stop signal | EM2 was turned off during one-touch tuning in the amplifier command method. | Review the one-touch tuning start position and permissible travel distance for the amplifier command method. After ensuring safety, turn on EM2. |
| C009 | Parameter | Parameters for manufacturer setting have been changed. | Return the parameters for manufacturer setting to the initial values. |
| C00A | Alarm | One-touch tuning was attempted to start in the amplifier command method during alarm or warning. Alarm or warning occurred during one-touch tuning by the amplifier command method. | Start one-touch tuning when no alarm or warning occurs. Prevent alarm or warning from occurring during one-touch tuning. |
| C00F | One-touch tuning disabled | "One-touch tuning function selection" in [Pr. PX13] is "Disabled (_ _ _ 0)". | Select "Enabled (_ _ _ 1)". |

6) If an alarm occurs

If an alarm occurs during the one-touch tuning, the tuning will be forcibly terminated. Remove the cause of the alarm and execute one-touch tuning again. When executing one-touch tuning in the amplifier command method again, return the moving part to the tuning start position.

7) If a warning occurs

If a warning which continues the motor driving occurs during one-touch tuning by the user command method, the tuning will be continued. If a warning which does not continue the motor driving occurs during the tuning, one-touch tuning will be stopped.
One-touch tuning will be stopped when warning occurs during one-touch tuning by the amplifier command method regardless of the warning type. Remove the cause of the warning, and return the moving part to the tuning start position. Then, execute the tuning again.

17. APPLICATION OF FUNCTIONS

8) Initializing one-touch tuning

Clicking "Return to initial value" in the one-touch tuning window of MR Configurator2 enables to return the parameter to the initial value. Refer to table 17.5 for the parameters which you can initialize.

Clicking "Return to value before adjustment" in the one-touch tuning window of MR Configurator2 enables to return the parameter to the value before clicking "Start".

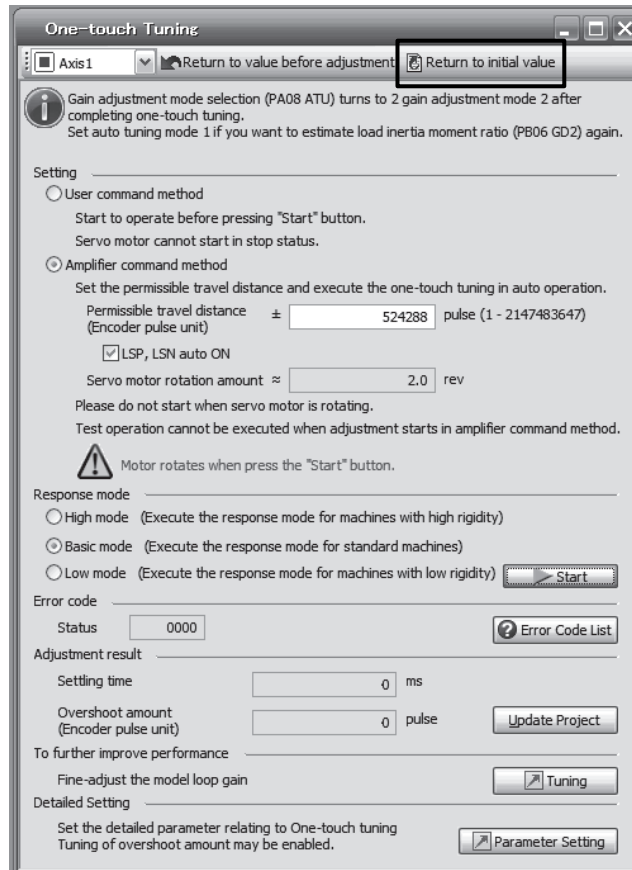

17. APPLICATION OF FUNCTIONS

- (c) Caution for one-touch tuning
 - 1) Caution common for user command method and amplifier command method
 - a) The tuning is not available in the torque control mode.
 - b) The one-touch tuning cannot be executed while an alarm or warning which does not continue the motor driving is occurring.
 - c) The one-touch tuning cannot be executed during the following test operation mode.
 - Output signal (DO) forced output
 - Motor-less operation
 - d) If one-touch tuning is performed when the gain switching function is enabled, vibration and/or unusual noise may occur during the tuning.
 - 2) Caution for amplifier command method
 - a) Starting one-touch tuning while the servo motor is rotating displays "C006" at status in error code, and the one-touch tuning cannot be executed.
 - b) Start one-touch tuning when all connected servo motors are at a stop.
 - c) One-touch tuning is not available during the test operation mode. The following test operation modes cannot be executed during one-touch tuning.
 - Positioning operation
 - JOG operation
 - Program operation
 - Machine analyzer operation
 - d) After one-touch tuning is executed, control will not be performed by commands from the servo system controller. To return to the state in which control is performed from the servo system controller, reset the controller or cycle the power of the servo amplifier.
 - e) During one-touch tuning, the permissible travel distance may be exceeded due to overshoot, set a value sufficient to prevent machine collision.
 - f) When Auto tuning mode 2, Manual mode, or 2 gain adjustment mode 2 is selected in [Pr. PA08 Auto tuning mode], the load to motor inertia ratio will not be estimated. An optimum acceleration/deceleration command will be generated by [Pr. PB06 Load to motor inertia ratio/load to motor mass ratio] at the start of one-touch tuning. When the load to motor inertia ratio is incorrect, the optimum acceleration/deceleration command may not be generated, causing the tuning to fail.
 - g) When one-touch tuning is started by using USB communication, if the USB communication is interrupted during the tuning, the servo motor will stop, and the tuning will also stop. The parameter will return to the one at the start of the one-touch tuning.
 - h) When one-touch tuning is started via the controller, if communication between the controller and the servo amplifier or personal computer is shut-off during the tuning, the servo motor will stop, and the tuning will also stop. The parameter will return to the one at the start of the one-touch tuning.
 - i) When one-touch tuning is started during the speed control mode, the mode will be switched to the position control mode automatically. The tuning result may differ from the one obtained by executing tuning by using the speed command.

17. APPLICATION OF FUNCTIONS

(5) Filter setting

The following filters are available with the J3 extension function.

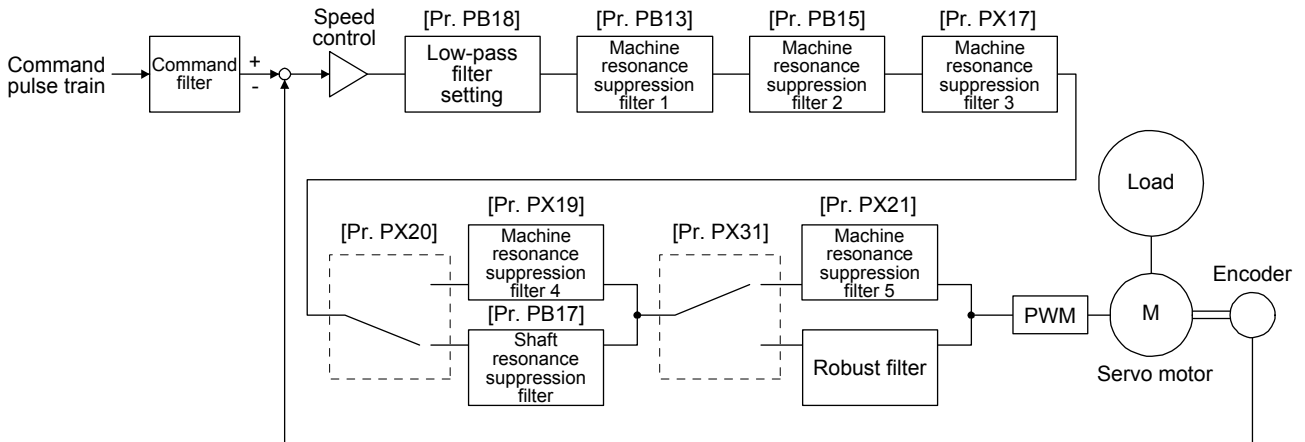

(a) Machine resonance suppression filter

| POINT |
|----------------------------------------------------------------------------------------------------------------------------------------------------------------------------------------------------------------------------------------------------------------------------------------------------------------------------------------------------------------------------------------------------------------------------------------------------------------------------------------------------------------------------------------------------------------------------------------------------------------------------------------------------------------------------------------------------------------------------------------------------------------------------------------------------------------------------------------------------------------------------------------------------------------------------------------------------------------|
| <ul style="list-style-type: none"> ● The machine resonance suppression filter is a delay factor for the servo system. Therefore, vibration may increase if you set an incorrect resonance frequency or set notch characteristics too deep or too wide. ● If the frequency of machine resonance is unknown, decrease the notch frequency from higher to lower ones in order. The optimum notch frequency is set at the point where vibration is minimal. ● A deeper notch has a higher effect on machine resonance suppression but increases a phase delay and may increase vibration. ● A wider notch has a higher effect on machine resonance suppression but increases a phase delay and may increase vibration. ● The machine characteristic can be grasped beforehand by the machine analyzer on MR Configurator2. This allows the required notch frequency and notch characteristics to be determined. |

If a mechanical system has a unique resonance point, increasing the servo system response level may cause resonance (vibration or unusual noise) in the mechanical system at that resonance frequency. Using the machine resonance suppression filter and adaptive tuning can suppress the resonance of the mechanical system. The setting range is 10 Hz to 4500 Hz.

17. APPLICATION OF FUNCTIONS

1) Function

The machine resonance suppression filter is a filter function (notch filter) which decreases the gain of the specific frequency to suppress the resonance of the mechanical system. You can set the gain decreasing frequency (notch frequency), gain decreasing depth and width.

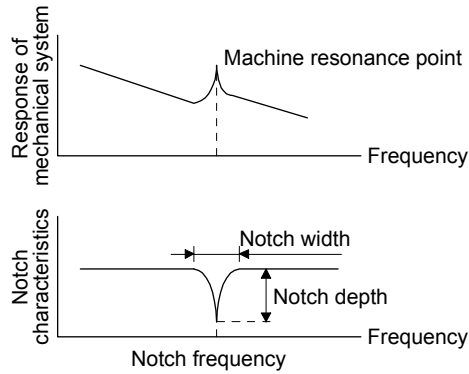

You can set five machine resonance suppression filters at most.

| Filter | Setting parameter | Precaution | Parameter that is reset with vibration tough drive function | Parameter automatically adjusted with one-touch tuning |
|----------------------------------------|-------------------|---------------------------------------------------------------------------------------------------------------------------------------------------------------------------------------------------------------------------------------------------------------------------------------------------------------------|-------------------------------------------------------------|--------------------------------------------------------|
| Machine resonance suppression filter 1 | PB01/PB13/PB14 | The filter can be set automatically with "Filter tuning mode selection" in [Pr. PB01]. | PB13 | PB01/PB13/PB14 |
| Machine resonance suppression filter 2 | PB15/PB16 | | PB15 | PB15/PB16 |
| Machine resonance suppression filter 3 | PX17/PX18 | | PX17/PX18 | |
| Machine resonance suppression filter 4 | PX19/PX20 | Enabling the machine resonance suppression filter 4 disables the shaft resonance suppression filter. Using the shaft resonance suppression filter is recommended because it is adjusted properly depending on the usage situation. The shaft resonance suppression filter is enabled for the initial setting. | | PX19/PX20 |
| Machine resonance suppression filter 5 | PX21/PX22 | Enabling the robust filter disables the machine resonance suppression filter 5. The robust filter is disabled for the initial setting. | | PX22 |

17. APPLICATION OF FUNCTIONS

2) Parameter

a) Machine resonance suppression filter 1 ([Pr. PB13] and [Pr. PB14])

Set the notch frequency, notch depth and notch width of the machine resonance suppression filter 1 ([Pr. PB13] and [Pr. PB14])

When you select "Manual setting (_ _ _ 2)" of "Filter tuning mode selection" in [Pr. PB01], the setting of the machine resonance suppression filter 1 is enabled.

b) Machine resonance suppression filter 2 ([Pr. PB15] and [Pr. PB16])

To use this filter, select "Enabled (_ _ _ 1)" of "Machine resonance suppression filter 2 selection" in [Pr. PB16].

How to set the machine resonance suppression filter 2 ([Pr. PB15] and [Pr. PB16]) is the same as for the machine resonance suppression filter 1 ([Pr. PB13] and [Pr. PB14]).

c) Machine resonance suppression filter 3 ([Pr. PX17] and [Pr. PX18])

To use this filter, select "Enabled (_ _ _ 1)" of "Machine resonance suppression filter 3 selection" in [Pr. PX18].

How to set the machine resonance suppression filter 3 ([Pr. PX17] and [Pr. PX18]) is the same as for the machine resonance suppression filter 1 ([Pr. PB13] and [Pr. PB14]).

d) Machine resonance suppression filter 4 ([Pr. PX19] and [Pr. PX20])

To use this filter, select "Enabled (_ _ _ 1)" of "Machine resonance suppression filter 4 selection" in [Pr. PX20]. However, enabling the machine resonance suppression filter 4 disables the shaft resonance suppression filter.

How to set the machine resonance suppression filter 4 ([Pr. PX19] and [Pr. PX20]) is the same as for the machine resonance suppression filter 1 ([Pr. PB13] and [Pr. PB14]).

e) Machine resonance suppression filter 5 ([Pr. PX21] and [Pr. PX22])

To use this filter, select "Enabled (_ _ _ 1)" of "Machine resonance suppression filter 5 selection" in [Pr. PX22]. However, enabling the robust filter ([Pr. PX31]: _ _ _ 1) disables the machine resonance suppression filter 5.

How to set the machine resonance suppression filter 5 ([Pr. PX21] and [Pr. PX22]) is the same as for the machine resonance suppression filter 1 ([Pr. PB13] and [Pr. PB14]).

17. APPLICATION OF FUNCTIONS

(b) Shaft resonance suppression filter

| POINT |
|------------------------------------------------------------------------------------------------------------------------------------------------------------------------------------------------------------------------------------------------------------------------------------------------------------------------------------------------|
| <p>● This filter is set properly by default according to servo motor you use and load moment of inertia. It is recommended that [Pr. PB23] be set to "___ 0" (automatic setting) because changing "Shaft resonance suppression filter selection" in [Pr. PB23] or [Pr. PB17 Shaft resonance suppression filter] may lower the performance.</p> |

1) Function

When a load is mounted to the servo motor shaft, resonance by shaft torsion during driving may generate a mechanical vibration at high frequency. The shaft resonance suppression filter suppresses the vibration.

When you select "Automatic setting", the filter will be set automatically on the basis of the servo motor you use and the load to motor inertia ratio. The disabled setting increases the response of the servo amplifier for high resonance frequency.

2) Parameter

Set "Shaft resonance suppression filter selection" in [Pr. PB23].

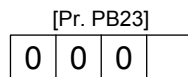

Shaft resonance suppression filter selection
 0: Automatic setting
 1: Manual setting
 2: Disabled

To set [Pr. PB17 Shaft resonance suppression filter] automatically, select "Automatic setting". To set [Pr. PB17 Shaft resonance suppression filter] manually, select "Manual setting". The setting values are as follows.

Shaft resonance suppression filter setting frequency selection

| Setting value | Frequency [Hz] | Setting value | Frequency [Hz] |
|---------------|----------------|---------------|----------------|
| __ 0 0 | Disabled | __ 1 0 | 562 |
| __ 0 1 | Disabled | __ 1 1 | 529 |
| __ 0 2 | 4500 | __ 1 2 | 500 |
| __ 0 3 | 3000 | __ 1 3 | 473 |
| __ 0 4 | 2250 | __ 1 4 | 450 |
| __ 0 5 | 1800 | __ 1 5 | 428 |
| __ 0 6 | 1500 | __ 1 6 | 409 |
| __ 0 7 | 1285 | __ 1 7 | 391 |
| __ 0 8 | 1125 | __ 1 8 | 375 |
| __ 0 9 | 1000 | __ 1 9 | 360 |
| __ 0 A | 900 | __ 1 A | 346 |
| __ 0 B | 818 | __ 1 B | 333 |
| __ 0 C | 750 | __ 1 C | 321 |
| __ 0 D | 692 | __ 1 D | 310 |
| __ 0 E | 642 | __ 1 E | 300 |
| __ 0 F | 600 | __ 1 F | 290 |

17. APPLICATION OF FUNCTIONS

(c) Advanced vibration suppression control II

| POINT | |
|-------|-----------------------------------------------------------------------------------------------------------------------------------------------------------------------------------------------|
| ● | This is enabled when "Gain adjustment mode selection" is "Auto tuning mode 2 (_ _ _ 2)" or "Manual mode (_ _ _ 3)" in [Pr. PA08]. |
| ● | The machine resonance frequency supported in the vibration suppression control tuning mode is 1.0 Hz to 100.0 Hz. As for the vibration out of the range, set manually. |
| ● | Stop the servo motor before changing the vibration suppression control-related parameters. Otherwise, it may cause an unexpected operation. |
| ● | For positioning operation during execution of vibration suppression control tuning, provide a stop time to ensure a stop after vibration damping. |
| ● | Vibration suppression control tuning may not make normal estimation if the residual vibration at the servo motor side is small. |
| ● | Vibration suppression control tuning sets the optimum parameter with the currently set control gains. When the response setting is increased, set vibration suppression control tuning again. |
| ● | When using the vibration suppression control 2, set " _ _ _ 1" in [Pr. PX02]. |

17. APPLICATION OF FUNCTIONS

1) Function

Vibration suppression control is used to further suppress load-side vibration, such as work-side vibration and base shake. The servo motor-side operation is adjusted for positioning so that the machine does not vibrate.

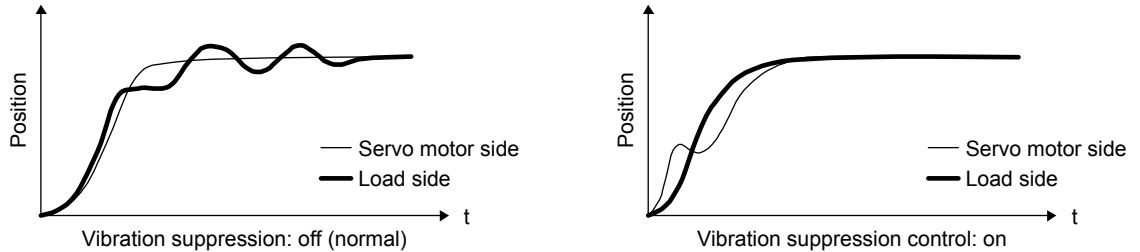

When the advanced vibration suppression control II ([Pr. PB02] and [Pr. PX03]) is executed, the vibration frequency at load side is automatically estimated to suppress machine side vibration two times at most.

In the vibration suppression control tuning mode, this mode shifts to the manual setting after the positioning operation is performed the predetermined number of times. For manual setting, adjust the vibration suppression control 1 with [Pr. PB19] to [Pr. PB22] and vibration suppression control 2 with [Pr. PX04] to [Pr. PX07].

2) Parameter

Set the advanced vibration suppression control II ([Pr. PB02] and [Pr. PX03]).

When you use a vibration suppression control, set "Vibration suppression control 1 tuning mode selection" in [Pr. PB02]. When you use two vibration suppression controls, set "Vibration suppression control 2 tuning mode selection" in [Pr. PX03] in addition.

[Pr. PB02]

0 0 0

Vibration suppression control 1 tuning mode

| Setting value | Vibration suppression control 1 tuning mode selection | Automatically set parameter |
|---------------|-------------------------------------------------------|-----------------------------|
| __ 0 | Disabled | |
| __ 1 | Automatic setting | PB19/PB20/PB21/PB22 |
| __ 2 | Manual setting | |

[Pr. PX03]

0 0 0

Vibration suppression control 2 tuning mode

| Setting value | Vibration suppression control 2 tuning mode selection | Automatically set parameter |
|---------------|-------------------------------------------------------|-----------------------------|
| __ 0 | Disabled | |
| __ 1 | Automatic setting | PX04/PX05/PX06/PX07 |
| __ 2 | Manual setting | |

17. APPLICATION OF FUNCTIONS

3) Vibration suppression control tuning procedure

The following flow chart is for the vibration suppression control 1. For the vibration suppression control 2, set " __ 1 _ " in [Pr. PX03] to execute the vibration suppression control tuning.

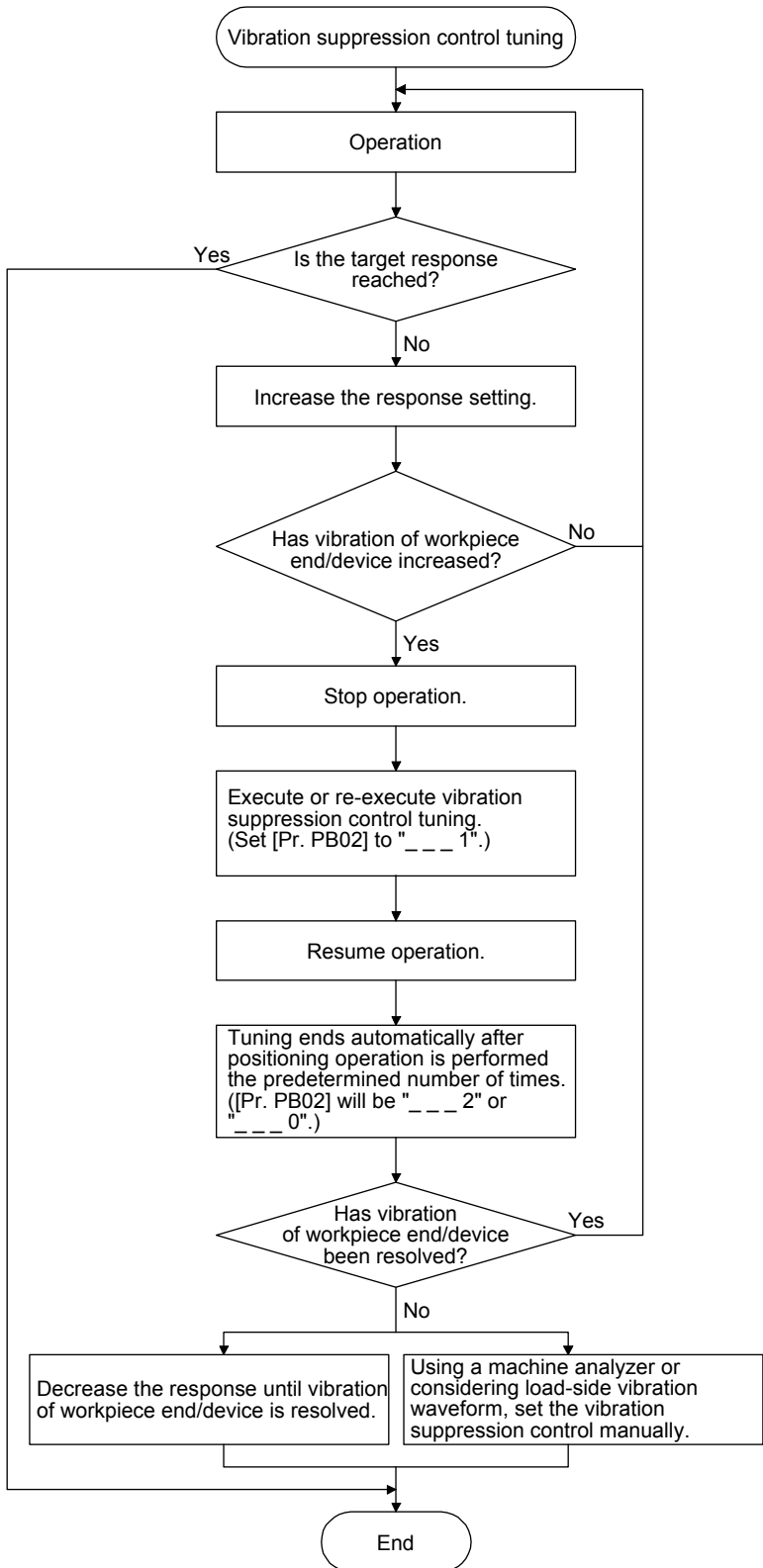

Factor

- Estimation cannot be made as load-side vibration has not been transmitted to the servo motor side.
- The response of the model loop gain has increased to the load-side vibration frequency (vibration suppression control limit).

17. APPLICATION OF FUNCTIONS

4) Vibration suppression control manual mode

| POINT |
|----------------------------------------------------------------------------------------------------------------------------------------------------------------------------------------------------------------------------------------------------------------------------------------------------------------------------------------------------------------------------------------------------------------------------------------------------------------------------------------------------------------------------------------------------------------------------------------------------------------------------------------------------------------------------------------|
| <ul style="list-style-type: none"> ● When load-side vibration does not show up in servo motor-side vibration, the setting of the servo motor-side vibration frequency does not produce an effect. ● When the anti-resonance frequency and resonance frequency can be confirmed using the machine analyzer or external equipment, do not set the same value but set different values to improve the vibration suppression performance. ● The setting range of [Pr. PB19], [Pr. PB20], [Pr. PX04], and [Pr. PX05] varies, depending on the value in [Pr. PB07]. If a value out of the range is set, the vibration suppression control will be disabled. |

Measure work-side vibration and device shake with the machine analyzer or external measuring instrument, and set the following parameters to adjust vibration suppression control manually.

| Setting item | Vibration suppression control 1 | Vibration suppression control 2 |
|-------------------------------------------------------------|---------------------------------|---------------------------------|
| Vibration suppression control - Vibration frequency | [Pr. PB19] | [Pr. PX04] |
| Vibration suppression control - Resonance frequency | [Pr. PB20] | [Pr. PX05] |
| Vibration suppression control - Vibration frequency damping | [Pr. PB21] | [Pr. PX06] |
| Vibration suppression control - Resonance frequency damping | [Pr. PB22] | [Pr. PX07] |

Step 1. Select "Manual setting (_ _ 2)" of "Vibration suppression control 1 tuning mode selection" in [Pr. PB02] or "Manual setting (_ _ 2 _)" of "Vibration suppression control 2 tuning mode selection" in [Pr. PX03].

Step 2. Set "Vibration suppression control - Vibration frequency" and "Vibration suppression control - Resonance frequency" as follows.

However, the value of [Pr. PB07 Model loop gain], vibration frequency, and resonance frequency have the following usable range and recommended range.

| Vibration suppression control | Usable range | Recommended setting range |
|---------------------------------|------------------------------------------------------------------------------------------------------------------------------------------------------------------------------------------------------------------------------------------------|----------------------------------------------------------------------------------------------------------------------------------------------------------------------------------------------|
| Vibration suppression control 1 | $[Pr. PB19] > 1/2\pi \times (0.9 \times [Pr. PB07])$ $[Pr. PB20] > 1/2\pi \times (0.9 \times [Pr. PB07])$ | $[Pr. PB19] > 1/2\pi \times (1.5 \times [Pr. PB07])$ $[Pr. PB20] > 1/2\pi \times (1.5 \times [Pr. PB07])$ |
| Vibration suppression control 2 | When $[Pr. PB19] < [Pr. PX04]$, $[Pr. PX04] > (5.0 + 0.1 \times [Pr. PB07])$ $[Pr. PX05] > (5.0 + 0.1 \times [Pr. PB07])$ $1.1 < [Pr. PX04]/[Pr. PB19] < 5.5$ $[Pr. PB07] < 2\pi (0.3 \times [Pr. PB19] + 1/8 \times [Pr. PX04])$ | When $[Pr. PB19] < [Pr. PX04]$, $[Pr. PX04], [Pr. PX05] > 6.25 \text{ Hz}$ $1.1 < [Pr. PX04]/[Pr. PB19] < 4$ $[Pr. PB07] < 1/3 \times (4 \times [Pr. PB19] + 2 \times [Pr. PX04])$ |

17. APPLICATION OF FUNCTIONS

a) When a vibration peak can be confirmed with machine analyzer using MR Configurator2, or external equipment.

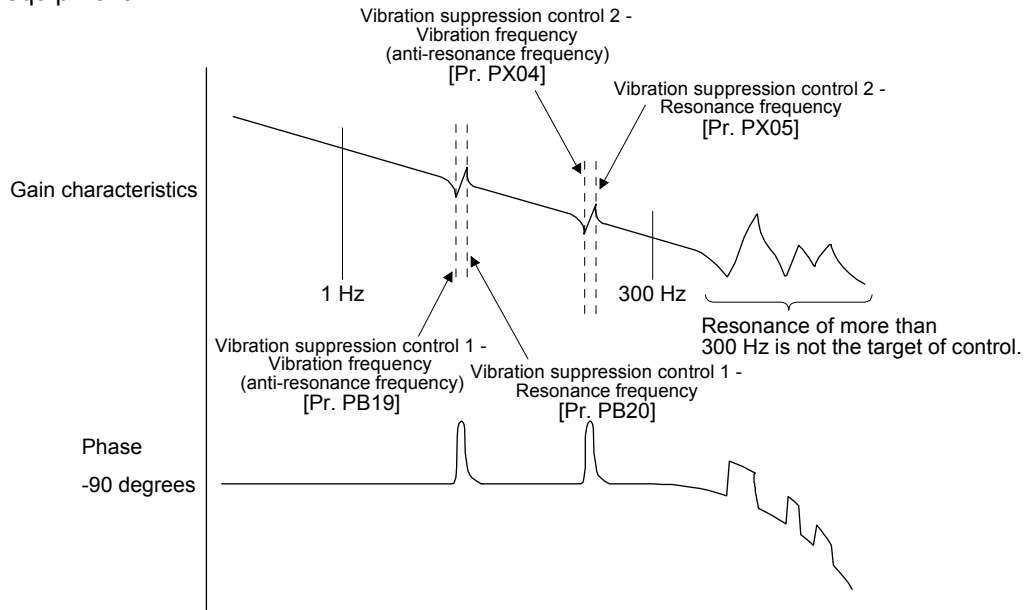

b) When vibration can be confirmed using monitor signal or external sensor

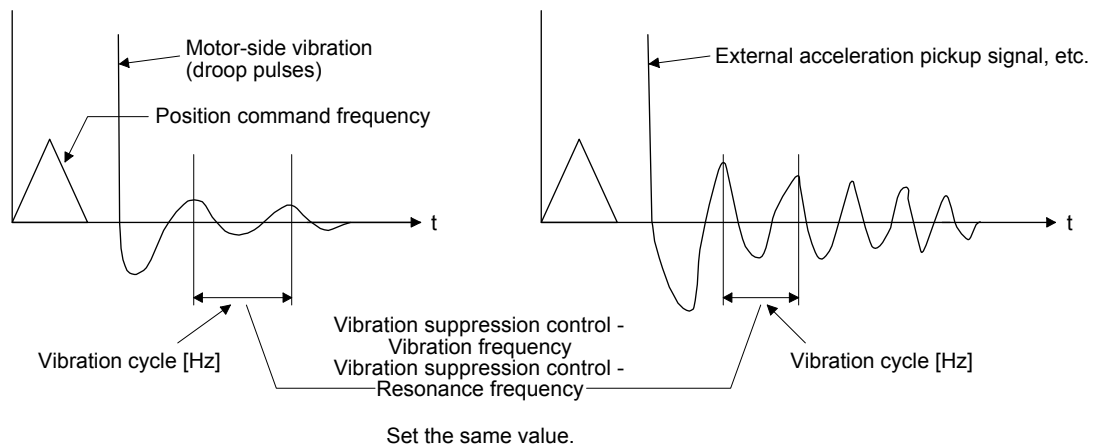

Step 3. Fine-adjust "Vibration suppression control - Vibration frequency damping" and "Vibration suppression control - Resonance frequency damping".

(6) Gain switching function

You can switch gains with the function. You can switch gains during rotation and during stop, and can use a control command from a controller to switch gains during operation.

(a) Use

The following shows when you use the function.

- 1) You want to increase the gains during servo-lock but decrease the gains to reduce noise during rotation.
- 2) You want to increase the gains during settling to shorten the stop settling time.
- 3) You want to change the gains using a control command from a controller to ensure stability of the servo system since the load to motor inertia ratio varies greatly during a stop (e.g. a large load is mounted on a carrier).

17. APPLICATION OF FUNCTIONS

(b) Function block diagram

The control gains, load to motor inertia ratio, and vibration suppression control settings are changed according to the conditions selected by [Pr. PB26 Gain switching function] and [Pr. PB27 Gain switching condition].

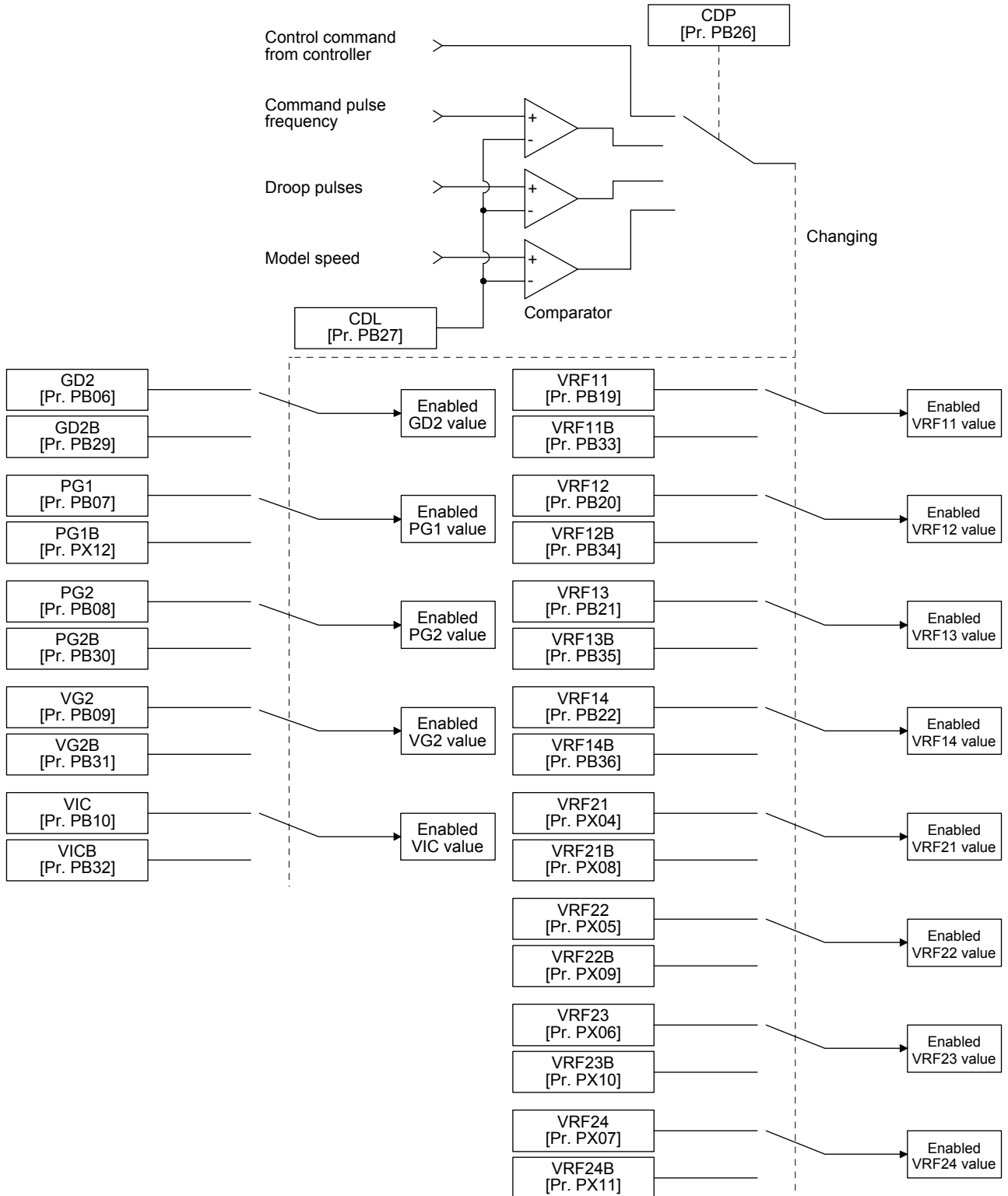

17. APPLICATION OF FUNCTIONS

(c) Parameter

When using the gain switching function, always select "Manual mode (_ _ _ 3)" of "Gain adjustment mode selection" in [Pr. PA08 Auto tuning mode]. The gain switching function cannot be used in the auto tuning mode.

1) Parameter for setting gain switching condition

| Parameter | Symbol | Name | Unit | Description |
|-----------|--------|------------------------------|------------------------------------|--------------------------------------------------------------|
| PB26 | CDP | Gain switching function | | Select a switching condition. |
| PB27 | CDL | Gain switching condition | [kpulse/s] /[pulse] /[r/min] | Set a switching condition values. |
| PB28 | CDT | Gain switching time constant | [ms] | Set the filter time constant for a gain switch at switching. |

a) [Pr. PB26 Gain switching function]

Set the gain switching condition. Select the switching condition in the first to third digits.

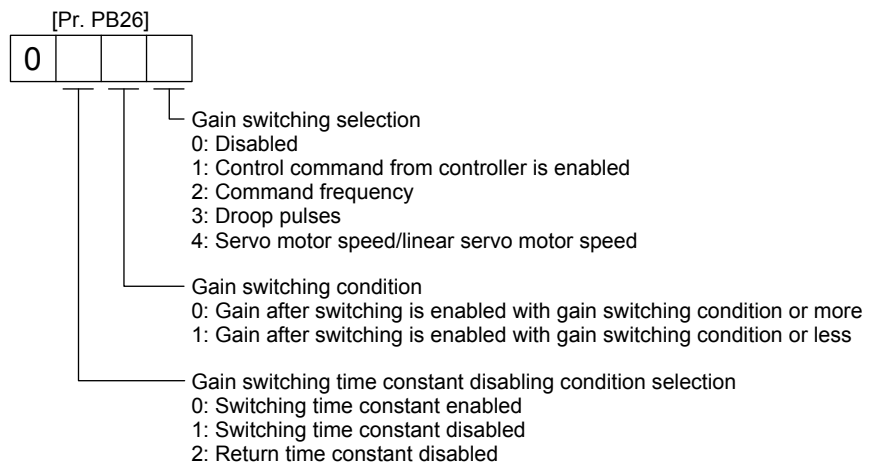

b) [Pr. PB27 Gain switching condition]

Set a level to switch gains with [Pr. PB27] after you select "Command frequency", "Droop pulses", or "Servo motor speed/linear servo motor speed" with the gain switching selection in [Pr. PB26 Gain switching function].

| Gain switching condition | Unit |
|--------------------------------------------|----------------|
| Command frequency | [kpulse/s] |
| Droop pulses | [pulse] |
| Servo motor speed/linear servo motor speed | [r/min]/[mm/s] |

c) [Pr. PB28 Gain switching time constant]

You can set the primary delay filter to each gain at gain switching. Use this parameter to suppress shock given to the machine if the gain difference is large at gain switching, for example.

17. APPLICATION OF FUNCTIONS

2) Switchable gain parameter

| Loop gain | Before switching | | | After switching | | |
|---------------------------------------------------------------|------------------|--------|---------------------------------------------------------------|-----------------|--------|------------------------------------------------------------------------------------|
| | Parameter | Symbol | Name | Parameter | Symbol | Name |
| Load to motor inertia ratio/load to motor mass ratio | PB06 | GD2 | Load to motor inertia ratio/load to motor mass ratio | PB29 | GD2B | Load to motor inertia ratio/load to motor mass ratio after gain switching |
| Model loop gain | PB07 | PG1 | Model loop gain | PX12 | PG1B | Model loop gain after gain switching |
| Position loop gain | PB08 | PG2 | Position loop gain | PB30 | PG2B | Position loop gain after gain switching |
| Speed loop gain | PB09 | VG2 | Speed loop gain | PB31 | VG2B | Speed loop gain after gain switching |
| Speed integral compensation | PB10 | VIC | Speed integral compensation | PB32 | VICB | Speed integral compensation after gain switching |
| Vibration suppression control 1 - Vibration frequency | PB19 | VRF11 | Vibration suppression control 1 - Vibration frequency | PB33 | VRF11B | Vibration suppression control 1 - Vibration frequency after gain switching |
| Vibration suppression control 1 - Resonance frequency | PB20 | VRF12 | Vibration suppression control 1 - Resonance frequency | PB34 | VRF12B | Vibration suppression control 1 - Resonance frequency after gain switching |
| Vibration suppression control 1 - Vibration frequency damping | PB21 | VRF13 | Vibration suppression control 1 - Vibration frequency damping | PB35 | VRF13B | Vibration suppression control 1 - Vibration frequency damping after gain switching |
| Vibration suppression control 1 - Resonance frequency damping | PB22 | VRF14 | Vibration suppression control 1 - Resonance frequency damping | PB36 | VRF14B | Vibration suppression control 1 - Resonance frequency damping after gain switching |
| Vibration suppression control 2 - Vibration frequency | PX04 | VRF21 | Vibration suppression control 2 - Vibration frequency | PX08 | VRF21B | Vibration suppression control 2 - Vibration frequency after gain switching |
| Vibration suppression control 2 - Resonance frequency | PX05 | VRF22 | Vibration suppression control 2 - Resonance frequency | PX09 | VRF22B | Vibration suppression control 2 - Resonance frequency after gain switching |
| Vibration suppression control 2 - Vibration frequency damping | PX06 | VRF23 | Vibration suppression control 2 - Vibration frequency damping | PX10 | VRF23B | Vibration suppression control 2 - Vibration frequency damping after gain switching |
| Vibration suppression control 2 - Resonance frequency damping | PX07 | VRF24 | Vibration suppression control 2 - Resonance frequency damping | PX11 | VRF24B | Vibration suppression control 2 - Resonance frequency damping after gain switching |

17. APPLICATION OF FUNCTIONS

a) [Pr. PB06] to [Pr. PB10]

These parameters are the same as in ordinary manual adjustment. Gain switching allows the values of load to motor inertia ratio/load to motor mass ratio, model loop gain, position loop gain, speed loop gain, and speed integral compensation to be switched.

b) [Pr. PB19] to [Pr. PB22]/[Pr. PX04] to [Pr. PX07]

These parameters are the same as in ordinary manual adjustment. You can switch the vibration frequency, resonance frequency, vibration frequency damping, and resonance frequency damping by switching gain during motor stop.

c) [Pr. PB29 Load to motor inertia ratio/load to motor mass ratio after gain switching]

Set the load to motor inertia ratio or load to motor mass ratio after gain switching. If the load to motor inertia ratio does not change, set it to the same value as [Pr. PB06 Load to motor inertia ratio/load to motor mass ratio].

d) [Pr. PB30 Position loop gain after gain switching], [Pr. PB31 Speed loop gain after gain switching], and [Pr. PB32 Speed integral compensation after gain switching]

Set the values of after switching position loop gain, speed loop gain and speed integral compensation.

e) Vibration suppression control after gain switching ([Pr. PB33] to [Pr. PB36]/[Pr. PX08] to [Pr. PX11])/[Pr. PX12 Model loop gain after gain switching]

The gain switching vibration suppression control and gain switching model loop gain are used only with control command from the controller.

You can switch the vibration frequency, resonance frequency, vibration frequency damping, resonance frequency damping, and model loop gain of the vibration suppression control 1 and vibration suppression control 2.

17. APPLICATION OF FUNCTIONS

(d) Gain switching procedure

This operation will be described by way of setting examples.

1) When you choose switching by control command from the controller

a) Setting example

| Parameter | Symbol | Name | Setting value | Unit |
|-----------|--------|------------------------------------------------------------------------------------|----------------------------------------------------------|--------------|
| PB06 | GD2 | Load to motor inertia ratio/load to motor mass ratio | 4.00 | [Multiplier] |
| PB07 | PG1 | Model loop gain | 100 | [rad/s] |
| PB08 | PG2 | Position loop gain | 120 | [rad/s] |
| PB09 | VG2 | Speed loop gain | 3000 | [rad/s] |
| PB10 | VIC | Speed integral compensation | 20 | [ms] |
| PB19 | VRF11 | Vibration suppression control 1 - Vibration frequency | 50 | [Hz] |
| PB20 | VRF12 | Vibration suppression control 1 - Resonance frequency | 50 | [Hz] |
| PB21 | VRF13 | Vibration suppression control 1 - Vibration frequency damping | 0.20 | |
| PB22 | VRF14 | Vibration suppression control 1 - Resonance frequency damping | 0.20 | |
| PX04 | VRF21 | Vibration suppression control 2 - Vibration frequency | 20 | [Hz] |
| PX05 | VRF22 | Vibration suppression control 2 - Resonance frequency | 20 | [Hz] |
| PX06 | VRF23 | Vibration suppression control 2 - Vibration frequency damping | 0.10 | |
| PX07 | VRF24 | Vibration suppression control 2 - Resonance frequency damping | 0.10 | |
| PB29 | GD2B | Load to motor inertia ratio/load to motor mass ratio after gain switching | 10.00 | [Multiplier] |
| PX12 | PG1B | Model loop gain after gain switching | 50 | [rad/s] |
| PB30 | PG2B | Position loop gain after gain switching | 84 | [rad/s] |
| PB31 | VG2B | Speed loop gain after gain switching | 4000 | [rad/s] |
| PB32 | VICB | Speed integral compensation after gain switching | 50 | [ms] |
| PB26 | CDP | Gain switching function | 0001 (Switch by control command from the controller.) | |
| PB28 | CDT | Gain switching time constant | 100 | [ms] |
| PB33 | VRF11B | Vibration suppression control 1 - Vibration frequency after gain switching | 60 | [Hz] |
| PB34 | VRF12B | Vibration suppression control 1 - Resonance frequency after gain switching | 60 | [Hz] |
| PB35 | VRF13B | Vibration suppression control 1 - Vibration frequency damping after gain switching | 0.15 | |
| PB36 | VRF14B | Vibration suppression control 1 - Resonance frequency damping after gain switching | 0.15 | |
| PX08 | VRF21B | Vibration suppression control 2 - Vibration frequency after gain switching | 30 | [Hz] |
| PX09 | VRF22B | Vibration suppression control 2 - Resonance frequency after gain switching | 30 | [Hz] |

17. APPLICATION OF FUNCTIONS

| Parameter | Symbol | Name | Setting value | Unit |
|-----------|--------|------------------------------------------------------------------------------------|---------------|------|
| PX10 | VRF23B | Vibration suppression control 2 - Vibration frequency damping after gain switching | 0.05 | |
| PX11 | VRF24B | Vibration suppression control 2 - Resonance frequency damping after gain switching | 0.05 | |

b) Switching timing chart

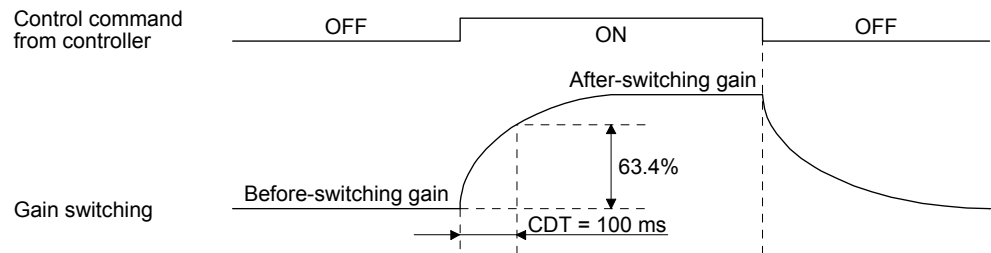

| | | | | | |
|---------------------------------------------------------------|------|---|-------|---|------|
| Model loop gain | 100 | → | 50 | → | 100 |
| Load to motor inertia ratio/load to motor mass ratio | 4.00 | → | 10.00 | → | 4.00 |
| Position loop gain | 120 | → | 84 | → | 120 |
| Speed loop gain | 3000 | → | 4000 | → | 3000 |
| Speed integral compensation | 20 | → | 50 | → | 20 |
| Vibration suppression control 1 - Vibration frequency | 50 | → | 60 | → | 50 |
| Vibration suppression control 1 - Resonance frequency | 50 | → | 60 | → | 50 |
| Vibration suppression control 1 - Vibration frequency damping | 0.20 | → | 0.15 | → | 0.20 |
| Vibration suppression control 1 - Resonance frequency damping | 0.20 | → | 0.15 | → | 0.20 |
| Vibration suppression control 2 - Vibration frequency | 20 | → | 30 | → | 20 |
| Vibration suppression control 2 - Resonance frequency | 20 | → | 30 | → | 20 |
| Vibration suppression control 2 - Vibration frequency damping | 0.10 | → | 0.05 | → | 0.10 |
| Vibration suppression control 2 - Resonance frequency damping | 0.10 | → | 0.05 | → | 0.10 |

17. APPLICATION OF FUNCTIONS

2) When you choose switching by droop pulses

The vibration suppression control after gain switching and model loop gain after gain switching cannot be used.

a) Setting example

| Parameter | Symbol | Name | Setting value | Unit |
|-----------|--------|---------------------------------------------------------------------------|-------------------------------------|--------------|
| PB06 | GD2 | Load to motor inertia ratio/load to motor mass ratio | 4.00 | [Multiplier] |
| PB08 | PG2 | Position loop gain | 120 | [rad/s] |
| PB09 | VG2 | Speed loop gain | 3000 | [rad/s] |
| PB10 | VIC | Speed integral compensation | 20 | [ms] |
| PB29 | GD2B | Load to motor inertia ratio/load to motor mass ratio after gain switching | 10.00 | [Multiplier] |
| PB30 | PG2B | Position loop gain after gain switching | 84 | [rad/s] |
| PB31 | VG2B | Speed loop gain after gain switching | 4000 | [rad/s] |
| PB32 | VICB | Speed integral compensation after gain switching | 50 | [ms] |
| PB26 | CDP | Gain switching selection | 0003 (switching by droop pulses) | |
| PB27 | CDL | Gain switching condition | 50 | [pulse] |
| PB28 | CDT | Gain switching time constant | 100 | [ms] |

b) Switching timing chart

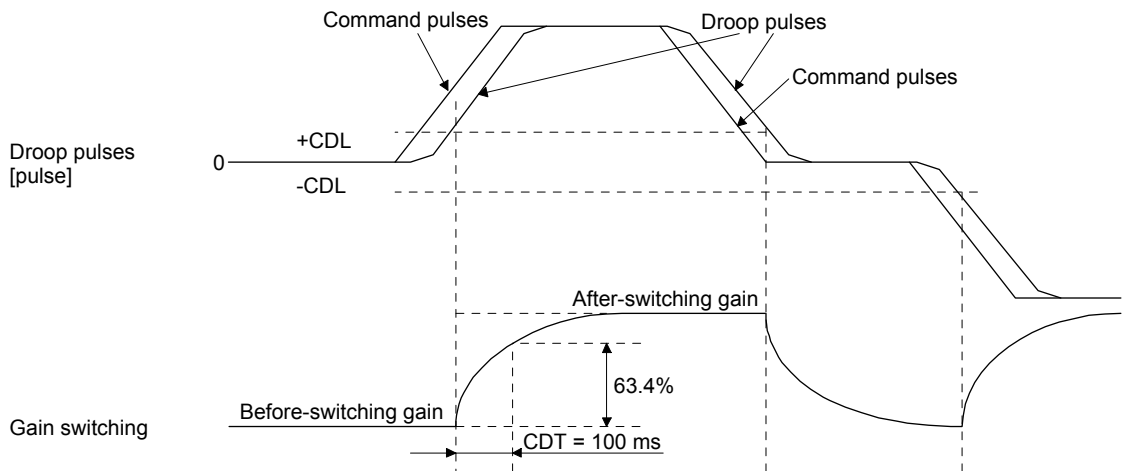

| | | | | | | | |
|------------------------------------------------------|------|---|-------|---|------|---|-------|
| Load to motor inertia ratio/load to motor mass ratio | 4.00 | → | 10.00 | → | 4.00 | → | 10.00 |
| Position loop gain | 120 | → | 84 | → | 120 | → | 84 |
| Speed loop gain | 3000 | → | 4000 | → | 3000 | → | 4000 |
| Speed integral compensation | 20 | → | 50 | → | 20 | → | 50 |

17. APPLICATION OF FUNCTIONS

3) When the gain switching time constant is disabled

a) Switching time constant disabled was selected.

The gain switching time constant is disabled. The time constant is enabled at gain return.
 The following example shows for [Pr. PB26 (CDP)] = 0103, [Pr. PB27 (CDL)] = 100 [pulse],
 and [Pr. PB28 (CDT)] = 100 [ms].

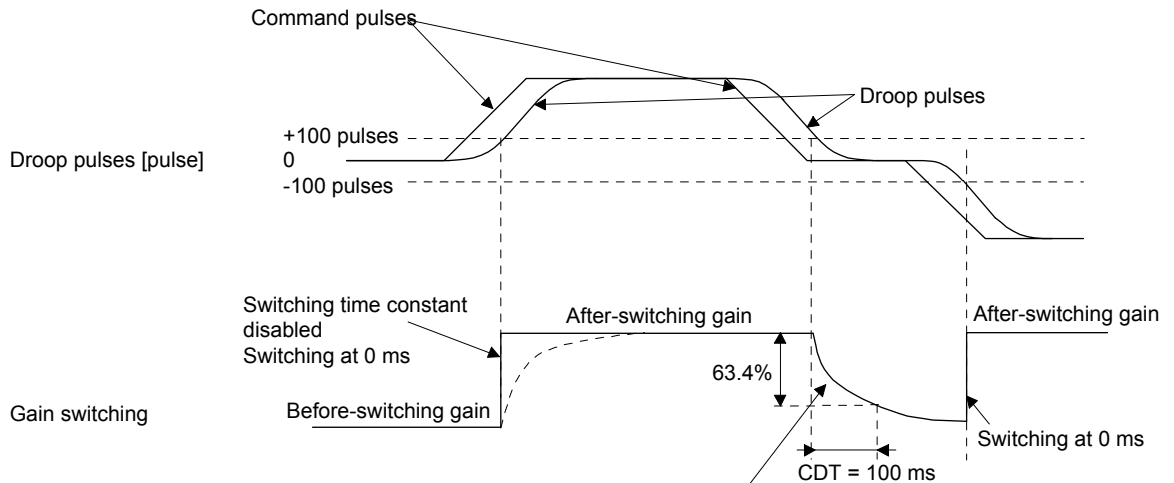

Switching at [Pr. PB28 (CDT)] = 100 [ms] only when gain switching off (when returning)

b) Return time constant disabled was selected.

The gain switching time constant is enabled. The time constant is disabled at gain return.
 The following example shows for [Pr. PB26 (CDP)] = 0201, [Pr. PB27 (CDL)] = 0, and [Pr.
 PB28 (CDT)] = 100 [ms].

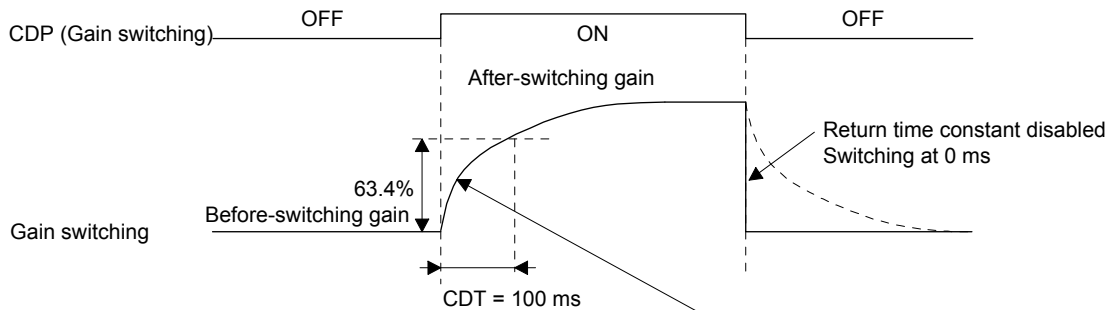

Switching at [Pr. PB28 (CDT)] = 100 [ms] only when gain switching on (when switching)

17. APPLICATION OF FUNCTIONS

(7) Tough drive function

| POINT |
|----------------------------------------------------------------------------------------------------------------------|
| ●Set enable/disable of the tough drive function with [Pr. PX25 Tough drive setting]. (Refer to (2) in this section.) |

This function makes the equipment continue operating even under the condition that an alarm occurs. The vibration tough drive function and instantaneous power failure tough drive function are available with the J3 extension function.

(a) Vibration tough drive function

This function prevents vibration by resetting a filter instantaneously when machine resonance occurs due to varied machine resonance frequency caused by machine aging.

To reset the machine resonance suppression filters with the function, [Pr. PB13 Machine resonance suppression filter 1] and [Pr. PB15 Machine resonance suppression filter 2] should be set in advance.

Set [Pr. PB13] and [Pr. PB15] as follows.

1) One-touch tuning execution (Refer to (4) in this section.)

2) Manual setting (Refer to (2) in this section.)

The vibration tough drive function operates when a detected machine resonance frequency is within $\pm 30\%$ for a value set in [Pr. PB13 Machine resonance suppression filter 1] or [Pr. PB15 Machine resonance suppression filter 2].

To set a detection level of the function, set sensitivity in [Pr. PX26 Vibration tough drive - Oscillation detection level].

| POINT |
|-----------------------------------------------------------------------------------------------------------------------------------------------------------------------------------------------------------------|
| ●Resetting [Pr. PB13] and [Pr. PB15] by the vibration tough drive function is performed constantly. However, the number of write times to the EEPROM is limited to once per hour. |
| ●The vibration tough drive function does not reset [Pr. PX17 Machine resonance suppression filter 3], [Pr. PX19 Machine resonance suppression filter 4], and [Pr. PX21 Machine resonance suppression filter 5]. |
| ●The vibration tough drive function does not detect a vibration of 100 Hz or less. |

17. APPLICATION OF FUNCTIONS

The following shows the function block diagram of the vibration tough drive function. The function detects machine resonance frequency and compares it with [Pr. PB13] and [Pr. PB15], and reset a machine resonance frequency of a parameter whose set value is closer.

| Filter | Setting parameter | Precaution | Parameter that is reset with vibration tough drive function |
|----------------------------------------|-------------------|---------------------------------------------------------------------------------------------------------------------------------------------------------------------------------------------------------------------------------------------------------------------------------------------------------------|-------------------------------------------------------------|
| Machine resonance suppression filter 1 | PB01/PB13/PB14 | The filter can be set automatically with "Filter tuning mode selection" in [Pr. PB01]. | PB13 |
| Machine resonance suppression filter 2 | PB15/PB16 | | PB15 |
| Machine resonance suppression filter 3 | PX17/PX18 | | |
| Machine resonance suppression filter 4 | PX19/PX20 | Enabling the machine resonance suppression filter 4 disables the shaft resonance suppression filter. Using the shaft resonance suppression filter is recommended because it is adjusted properly depending on the usage situation. The shaft resonance suppression filter is enabled for the initial setting. | |
| Machine resonance suppression filter 5 | PX21/PX22 | Enabling the robust filter disables the machine resonance suppression filter 5. The robust filter is disabled for the initial setting. | |

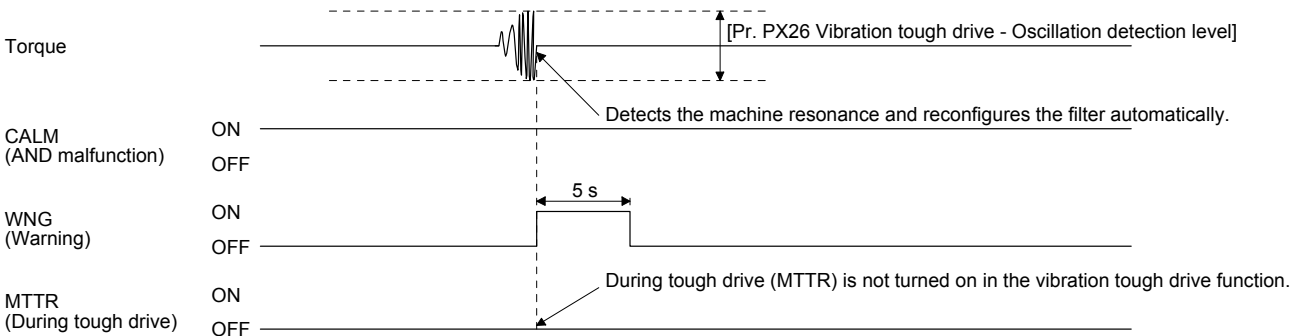
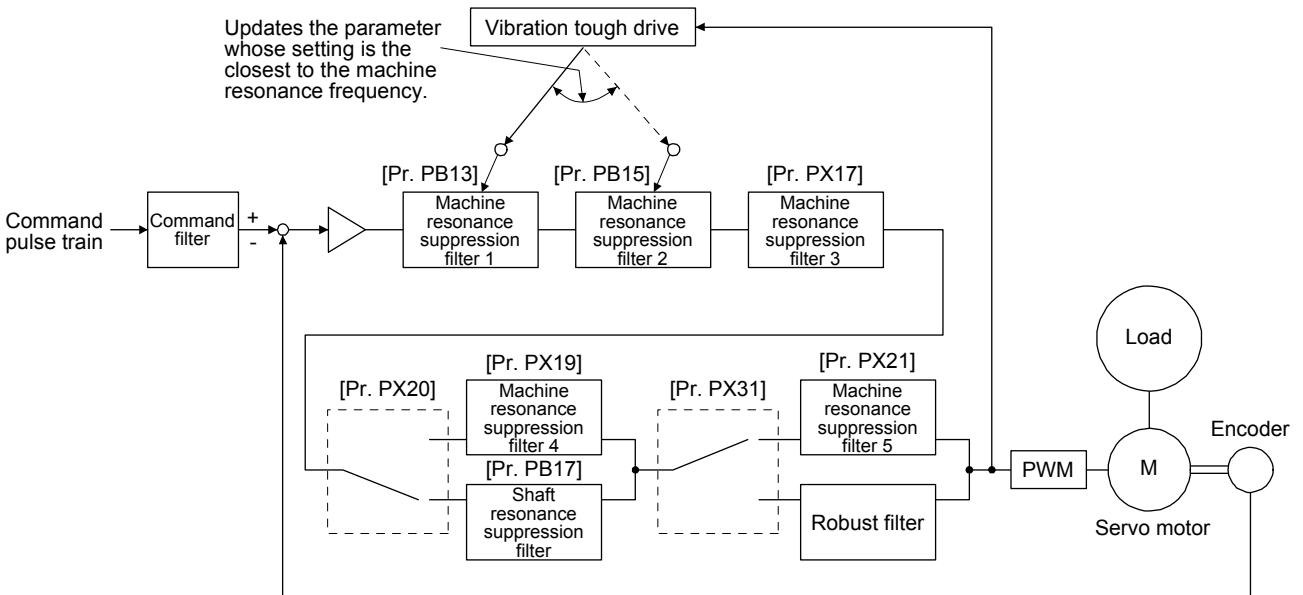

17. APPLICATION OF FUNCTIONS

(b) Instantaneous power failure tough drive function

The instantaneous power failure tough drive function avoids [AL. 10 Undervoltage] even when an instantaneous power failure occurs during operation. When the instantaneous power failure tough drive activates, the function will increase the immunity to instantaneous power failures using the electrical energy charged in the capacitor in the servo amplifier and will change an alarm level of [AL. 10 Undervoltage] simultaneously. The [AL. 10.1 Voltage drop in the control circuit power] detection time for the control circuit power supply can be changed by [Pr. PX28 SEMI-F47 function - Instantaneous power failure detection time]. In addition, [AL. 10.2 Voltage drop in the main circuit power] detection level for the bus voltage is changed automatically.

| POINT |
|------------------------------------------------------------------------------------------------------------------------------------------------------------------------------------------------------------------------------------------------------------------------------------------------------------------------------------------------------------------------------------------------------------------------------------------------------------------------------------------------------------------------------------------------------------------------------------------------------------------------------------------------------------------------------------------------------------------------------------------------------------------------------------------------------------------------------------------------------------------------------------------------------------------------------------------------------------------------------------------------------------------------------------------------------------------------------------------------------------------------------------------------------------------------------------------------------------------------------------------------|
| <ul style="list-style-type: none">● MBR (Electromagnetic brake interlock) will not turn off during the instantaneous power failure tough drive.● When the load of instantaneous power failure is large, [AL. 10.2] caused by the bus voltage drop may occur regardless of the set value of [Pr. PX28 SEMI-F47 function - Instantaneous power failure detection time].● The MR-J4W2-0303B6 servo amplifier is not compatible with instantaneous power failure tough drive.● The setting range of [Pr. PX28 SEMI-F47 function - Instantaneous power failure detection time] differs depending on the software version of the servo amplifier as follows.<ul style="list-style-type: none">▪ Software version C0 or later: Setting range 30 ms to 200 ms▪ Software version C1 or earlier: Setting range 30 ms to 500 msTo comply with SEMI-F47 standard, it is unnecessary to change the initial value (200 ms). However, when the instantaneous power failure time exceeds 200 ms, and the instantaneous power failure voltage is less than 70% of the rated input voltage, the power may be normally turned off even if a value larger than 200 ms is set in the parameter. |

17. APPLICATION OF FUNCTIONS

- 1) Instantaneous power failure time of control circuit power supply > [Pr. PX28 SEMI-F47 function - Instantaneous power failure detection time]

The alarm occurs when the instantaneous power failure time of the control circuit power supply exceeds [Pr. PX28 SEMI-F47 function - Instantaneous power failure detection time].

MTTR (During tough drive) turns on after the instantaneous power failure is detected.

MBR (Electromagnetic brake interlock) turns off when the alarm occurs.

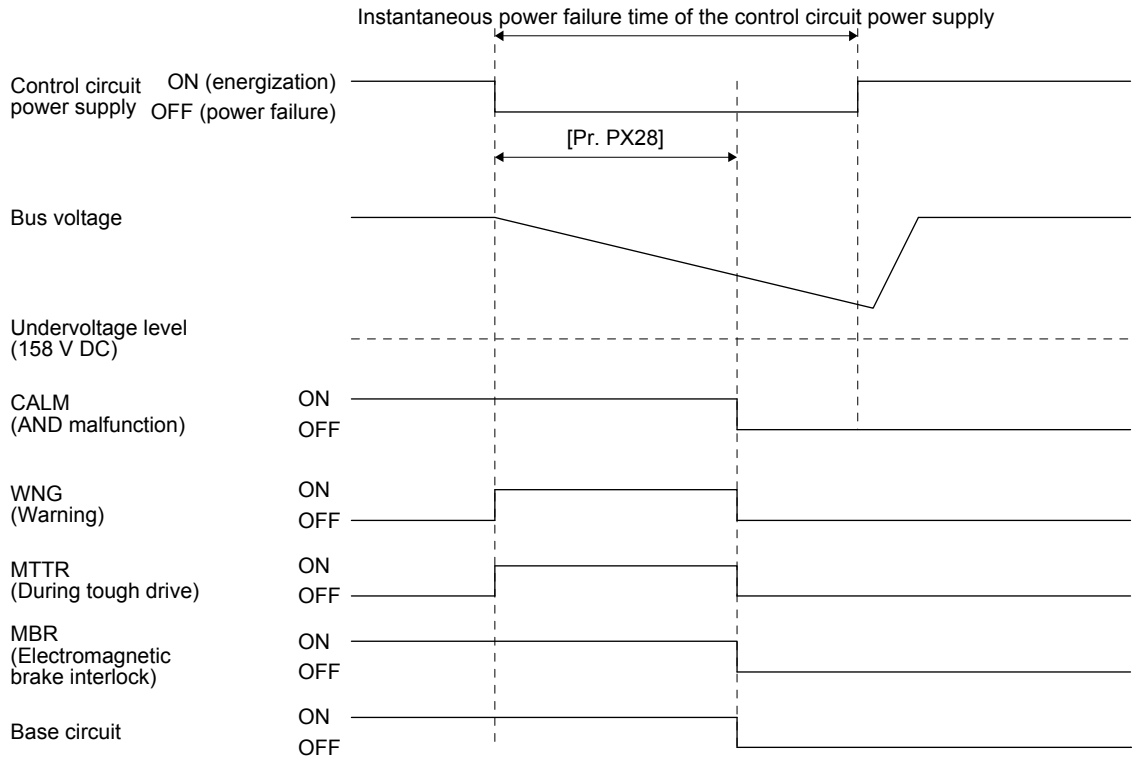

17. APPLICATION OF FUNCTIONS

2) Instantaneous power failure time of control circuit power supply < [Pr. PX28 SEMI-F47 function - Instantaneous power failure detection time]

Operation status differs depending on how bus voltage decrease.

a) When the bus voltage decreases lower than 158 V DC within the instantaneous power failure time of the control circuit power supply [AL. 10 Undervoltage] occurs when the bus voltage decrease lower than 158 V DC regardless of the enabled instantaneous power failure tough drive.

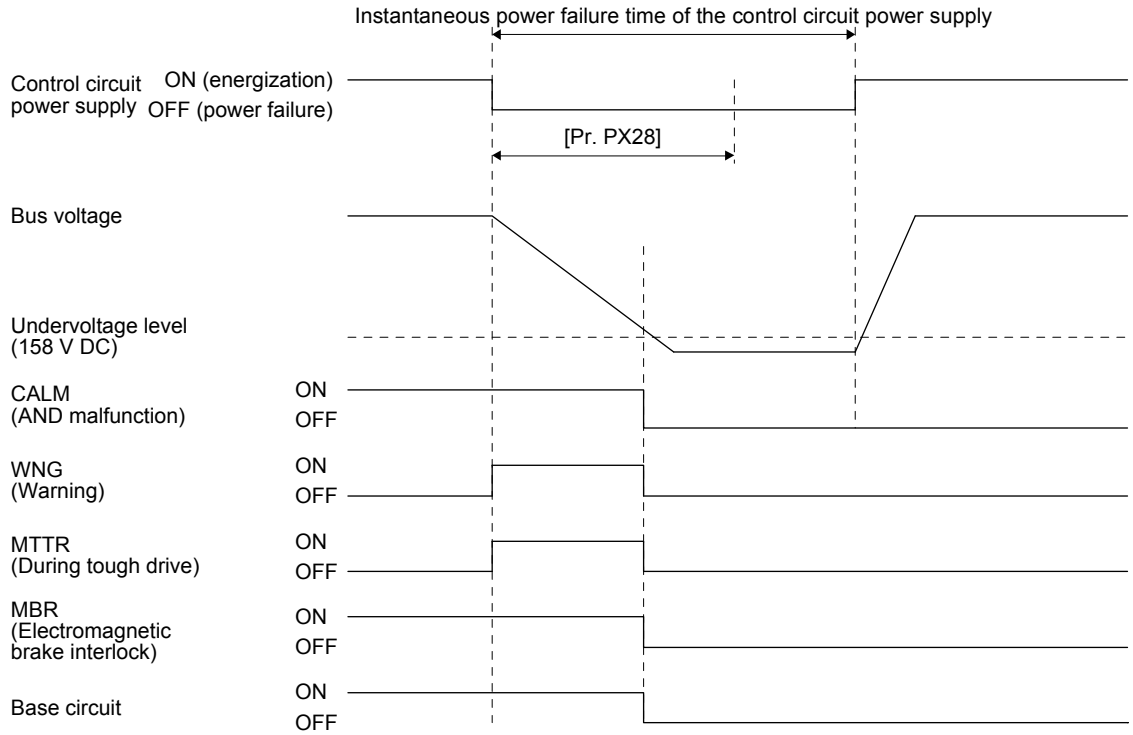

17. APPLICATION OF FUNCTIONS

- b) When the bus voltage does not decrease lower than 158 V DC within the instantaneous power failure time of the control circuit power supply
 The operation continues without alarming.

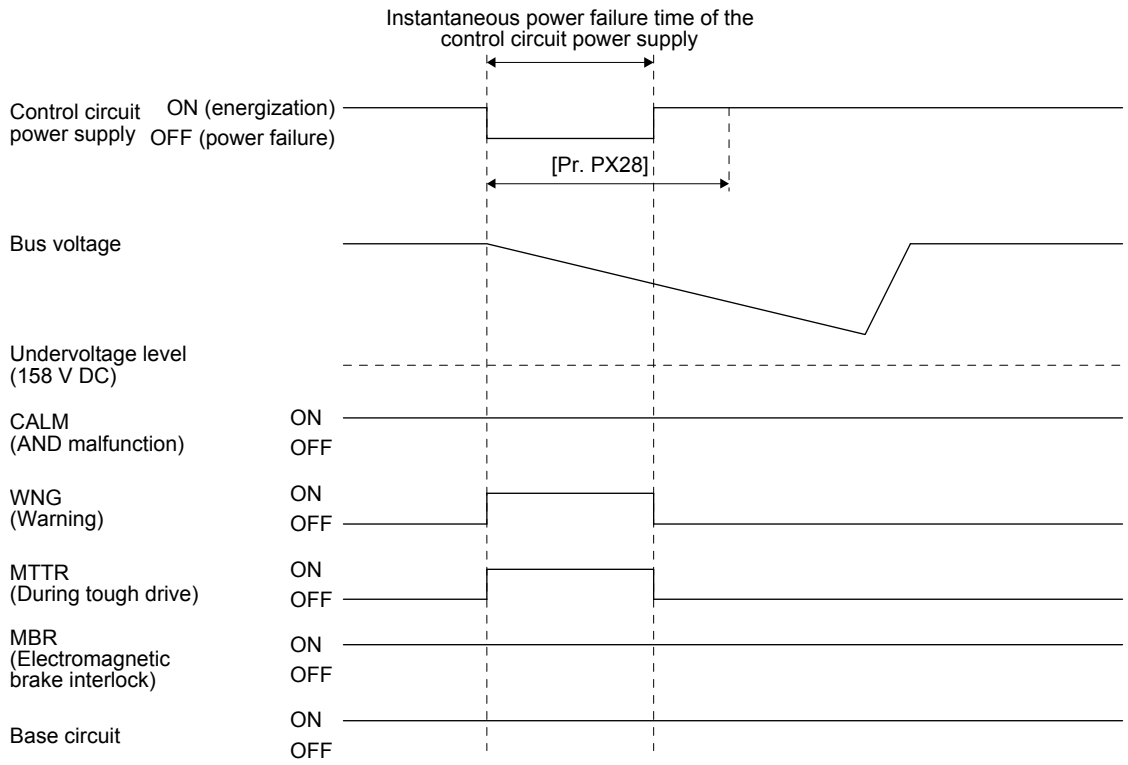

17. APPLICATION OF FUNCTIONS

(8) Compliance with SEMI-F47 standard

| POINT |
|------------------------------------------------------------------------------------------------------------------------------------------------------------------------------------------------------------------------------------------------------------------------------------------------------------------------------------------------------------------------------------------------------------------------------------------------------------------------------------------------------------------------------------------------------------------------------------------------------------------------------------------------------------------------------------------------------|
| <ul style="list-style-type: none"> ● The control circuit power supply of the MR-J4W_-_B 200 W or more servo amplifier can comply with SEMI-F47 standard. However, a back-up capacitor may be necessary for instantaneous power failure in the main circuit power supply depending on the power supply impedance and operating situation. Be sure to check them by testing the entire equipment using actual machines. ● Use a 3-phase for the input power supply of the servo amplifier. Using a 1-phase 200 V AC for the input power supply will not comply with SEMI-F47 standard. ● The MR-J4W2-0303B6 servo amplifier is not compatible with SEMI-F47 standard. |

The following explains the compliance with "SEMI-F47 semiconductor process equipment voltage sag immunity test" of MR-J4 series.

This function enables to avoid triggering [AL. 10 Undervoltage] using the electrical energy charged in the capacitor in case that an instantaneous power failure occurs during operation.

(a) Parameter setting

Setting [Pr. PX25] and [Pr. PX28] as follows will enable SEMI-F47 function.

| Parameter | Setting value | Description |
|-----------|---------------|-------------------------------------------------------------------------------------------------|
| PX25 | _ 1 _ _ | Enable SEMI-F47 function selection. |
| PX28 | 200 | Set the time [ms] until the occurrence of [AL. 10.1 Voltage drop in the control circuit power]. |

Enabling SEMI-F47 function will change operation as follows.

- 1) The voltage will drop in the control circuit power at "Rated voltage × 50% or less". After 200 ms, [AL. 10.1 Voltage drop in the control circuit power] will occur.
- 2) [AL. 10.2 Voltage drop in the main circuit power] will occur with 158 V DC or less in bus voltage.
- 3) MBR (Electromagnetic brake interlock) will turn off when [AL. 10.1 Voltage drop in the control circuit power] occurs.

(b) Requirement of SEMI-F47 standard

Table 17.8 shows the permissible time of instantaneous power failure for instantaneous power failure of SEMI-F47 standard.

Table 17.8 Requirement of SEMI-F47 standard

| Instantaneous power failure voltage | Permissible time of instantaneous power failure [s] |
|-------------------------------------|-----------------------------------------------------|
| Rated voltage × 80% | 1 |
| Rated voltage × 70% | 0.5 |
| Rated voltage × 50% | 0.2 |

17. APPLICATION OF FUNCTIONS

(c) Calculation of tolerance against instantaneous power failure

Table 17.9 shows tolerance against instantaneous power failure when instantaneous power failure voltage is "rated voltage × 50%" and instantaneous power failure time is 200 ms.

Table 17.9 Tolerance against instantaneous power failure (instantaneous power failure voltage = rated voltage × 50%, instantaneous power failure time = 200 ms)

| Servo amplifier | Instantaneous maximum output [W] | Tolerance against instantaneous power failure [W] (voltage drop between lines) |
|-----------------|----------------------------------|--------------------------------------------------------------------------------|
| MR-J4W2-22B | 1400 (700 × 2) | 790 |
| MR-J4W2-44B | 2800 (1400 × 2) | 1190 |
| MR-J4W2-77B | 5250 (2625 × 2) | 2300 |
| MR-J4W2-1010B | 6000 (3000 × 2) | 2400 |
| MR-J4W3-222B | 2100 (700 × 3) | 970 |
| MR-J4W3-444B | 4200 (1400 × 3) | 1700 |

Instantaneous maximum output means power which servo amplifier can output in maximum torque at rated speed. You can examine margins to compare the values of following conditions and instantaneous maximum output.

Even if driving at maximum torque with low speed in actual operation, the motor will not drive with the maximum output. This can be handled as a margin.

The following shows the conditions of tolerance against instantaneous power failure.

1) Delta connection

For the 3-phase (L1/L2/L3) delta connection, an instantaneous power failure occurs in the voltage between a pair of lines (e.g. between L1 and L2) among voltages between three pairs of lines (between L1 and L2, L2 and L3, or L3 and L1).

2) Star connection

For the 3-phase (L1/L2/L3/neutral point N) star connection, an instantaneous power failure occurs in the voltage between a pair of lines (e.g. between L1 and N) among voltages at six locations, between three pairs of lines (between L1 and L2, L2 and L3, or L3 and L1) and between one of the lines and the neutral point (between L1 and N, L2 and N, or L3 and N).

17. APPLICATION OF FUNCTIONS

17.2 Scale measurement function

The scale measurement function transmits position information of a scale measurement encoder to the controller by connecting the scale measurement encoder in semi closed loop control.

| POINT |
|----------------------------------------------------------------------------------------------------------------------------------------------------------------------------------------------------------------------------------------------------------------------------------------------------------------------------------------------------------------------------------------------------------------------------------------------------------------------------------------------------------------------------------------------------------------------------------------------------------------------------------------------------------------------------------------------------------------------------------------------------------------------------------------------------------------------------------------------------------------------------------------------------------------------------------------------------------------------------------------------------------------------------------------------------------------------------------------------------------------------------------------------------------------------------------------------------------------------------------------------------------------------------------------------------------------------------------------------------------------------------------------------------------------------------------------------------------------------------------------------------------------------------------------------------------------------------------------------------------------------------------------------------------------------------------------------------------------------------------|
| <ul style="list-style-type: none"> ● The scale measurement function is available only with MR-J4W2-_B. It will not be available with MR-J4W3-_B. ● The scale measurement function is available for the servo amplifiers of software version A8 or later. ● When a linear encoder is used as a scale measurement encoder for this servo amplifier, "Linear Encoder Instruction Manual" is necessary. ● When the scale measurement function is used for MR-J4W2-_B servo amplifiers, the following restrictions apply. <ul style="list-style-type: none"> ▪ A/B/Z-phase differential output type encoder cannot be used. ▪ The scale measurement encoder and servo motor encoder are compatible with only the two-wire type. The four-wire type load-side encoder and servo motor encoder cannot be used. ▪ When you use the HG-KR and HG-MR series for driving and load-side encoder, the optional four-wire type encoder cables (MR-EKCBL30M-L, MR-EKCBL30M-H, MR-EKCBL40M-H, and MR-EKCBL50M-H) cannot be used. When an encoder cable of 30 m to 50 m is needed, fabricate a two-wire type encoder cable according to app. 9. ● The scale measurement function compatible servo amplifier can be used with any of the following controllers. <ul style="list-style-type: none"> ▪ Motion controller R_MTCPU/Q17_DSCPU For settings and restrictions of controllers compatible with the scale measurement function, refer to user's manuals for each controller. ● The MR-J4W2-0303B6 servo amplifier is not compatible with the scale measurement function. |

17.2.1 Functions and configuration

(1) Function block diagram

The following shows a block diagram of the scale measurement function. The control will be performed per servo motor encoder unit for the scale measurement function.

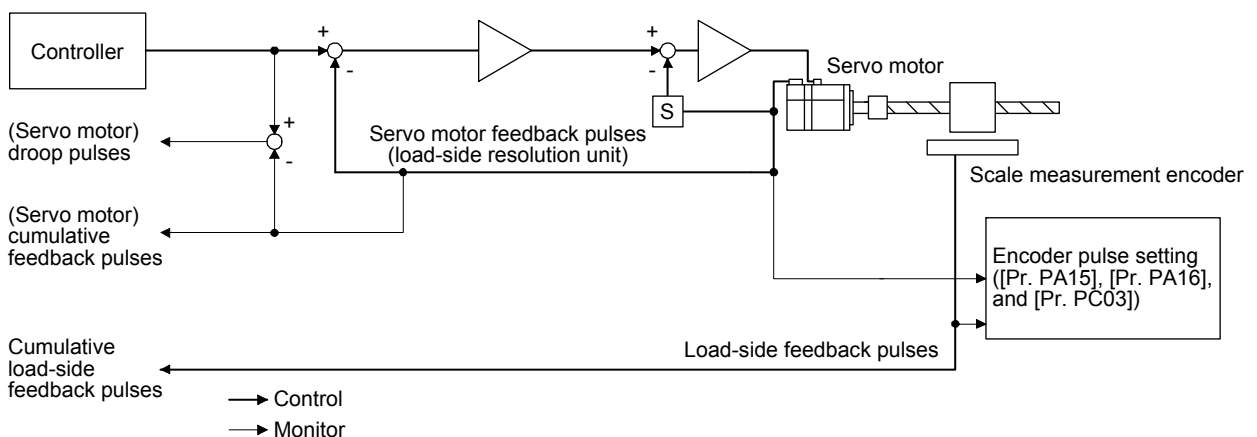

17. APPLICATION OF FUNCTIONS

- (2) System configuration
 - (a) For a linear encoder

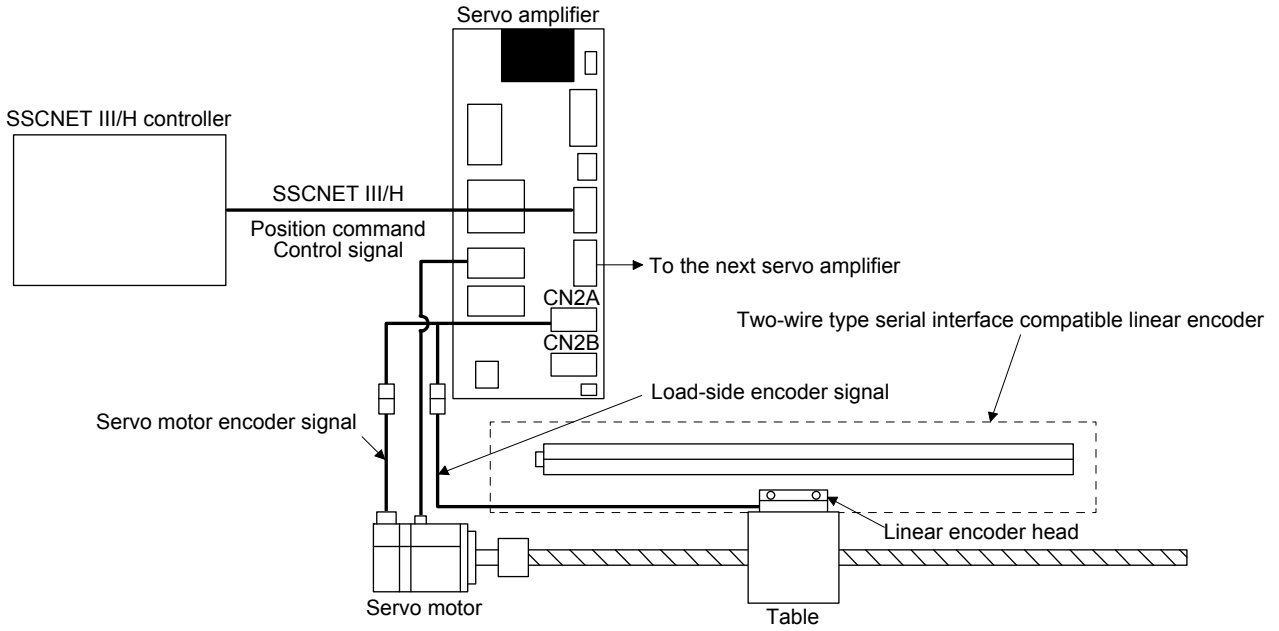

- (b) For a rotary encoder

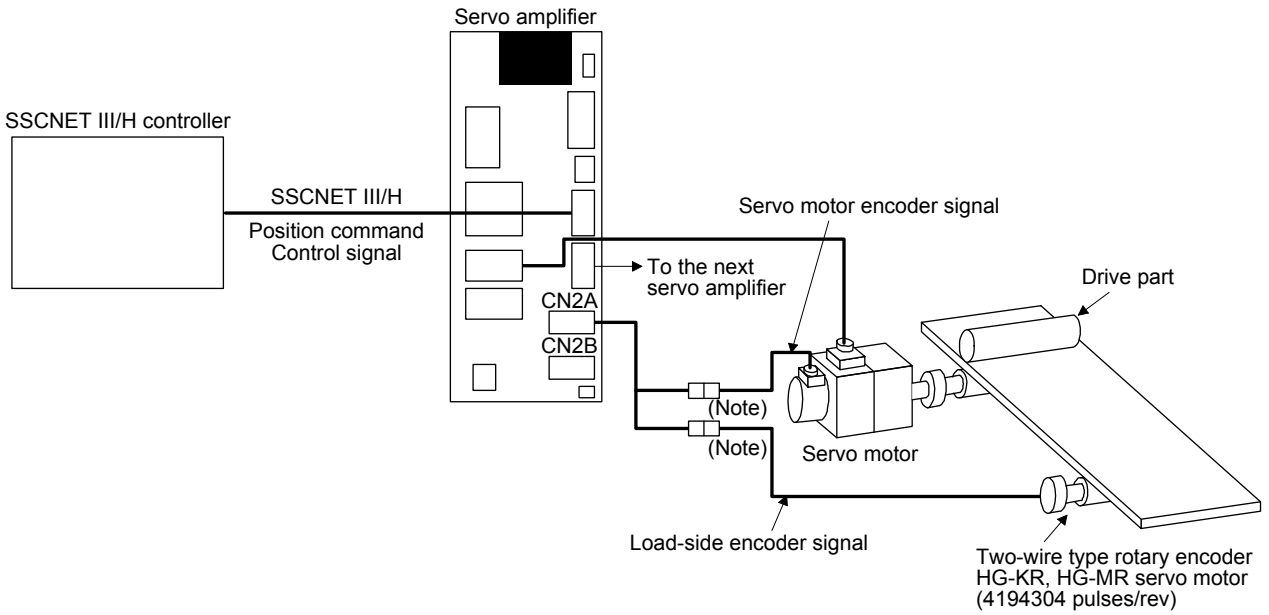

Note. Use a two-wire type encoder cable. A four-wire type linear encoder cable cannot be used.

17. APPLICATION OF FUNCTIONS

17.2.2 Scale measurement encoder

| POINT |
|--------------------------------------------------------------------------------------------------------------------------------------------------------------------------------------------------------------------------------------------------------------------------------------------------------------------|
| <ul style="list-style-type: none"> ● Always use the scale measurement encoder cable introduced in this section. Using other products may cause a malfunction. ● For details of the scale measurement encoder specifications, performance and assurance, contact each encoder manufacturer. |

(1) Linear encoder

Refer to "Linear Encoder Instruction Manual" for usable linear encoders.

To use the scale measurement function in the absolute position detection system ([Pr. PA22] = 1___), an absolute position linear encoder is required. In this case, you do not need to install the encoder battery to the servo amplifier for backing up the absolute position data of the load side. To use a servo motor in the absolute position detection system ([Pr. PA03] = __ _1), the encoder battery must be installed to the servo amplifier for backing up the absolute position data of the servo motor side.

(2) Rotary encoder

When a rotary encoder is used as a scale measurement encoder, use the following servo motor as the encoder.

Servo motors used as encoders

| | HG-KR | HG-MR |
|------------|-------|-------|
| MR-J4W2-_B | ○ | ○ |

Use a two-wire type encoder cable. Do not use MR-EKCBL30M-L, MR-EKCBL30M-H, MR-EKCBL40M-H, or MR-EKCBL50M-H as they are four-wire type.

When an encoder cable of 30 m to 50 m is needed, fabricate a two-wire type encoder cable according to app. 9.

To use the scale measurement function in the absolute position detection system ([Pr. PA22] = 1___), the encoder battery must be installed to the servo amplifier for backing up the absolute position data of the load side. In this case, the battery life will be shorter because the power consumption is increased as the power is supplied to the two encoders of motor side and load side.

17. APPLICATION OF FUNCTIONS

(3) Configuration diagram of encoder cable

Configuration diagram for servo amplifier and scale measurement encoder is shown below. Cables vary depending on the scale measurement encoder.

(a) Linear encoder

Refer to "Linear Encoder Instruction Manual" for encoder cables for linear encoder.

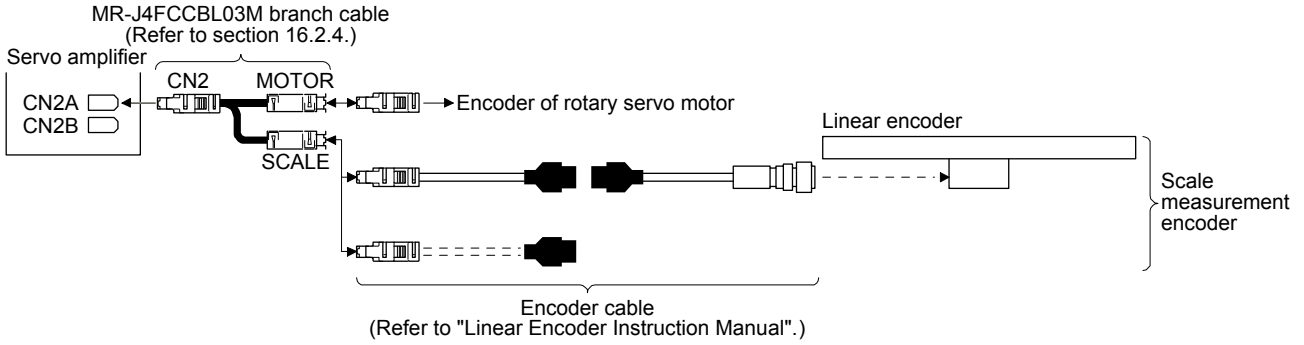

(b) Rotary encoder

Refer to "Servo Motor Instruction Manual (Vol. 3)" for encoder cables for rotary encoders.

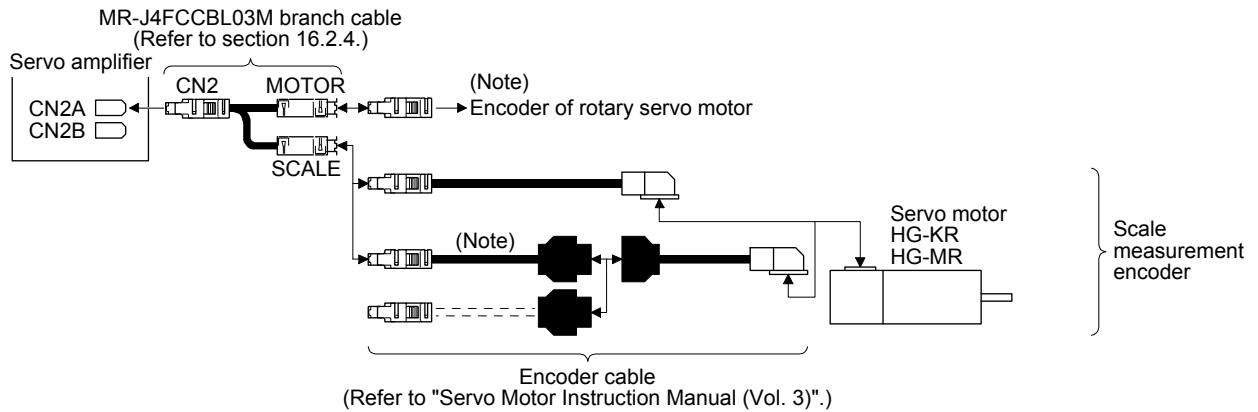

Note. Use a two-wire type encoder cable. A four-wire type linear encoder cable cannot be used.

17. APPLICATION OF FUNCTIONS

(4) MR-J4FCCBL03M branch cable

Use MR-J4FCCBL03M branch cable to connect the scale measurement encoder to CN2A or CN2B connector.

When fabricating the branch cable using MR-J3THMCN2 connector set, refer to "Linear Encoder Instruction Manual".

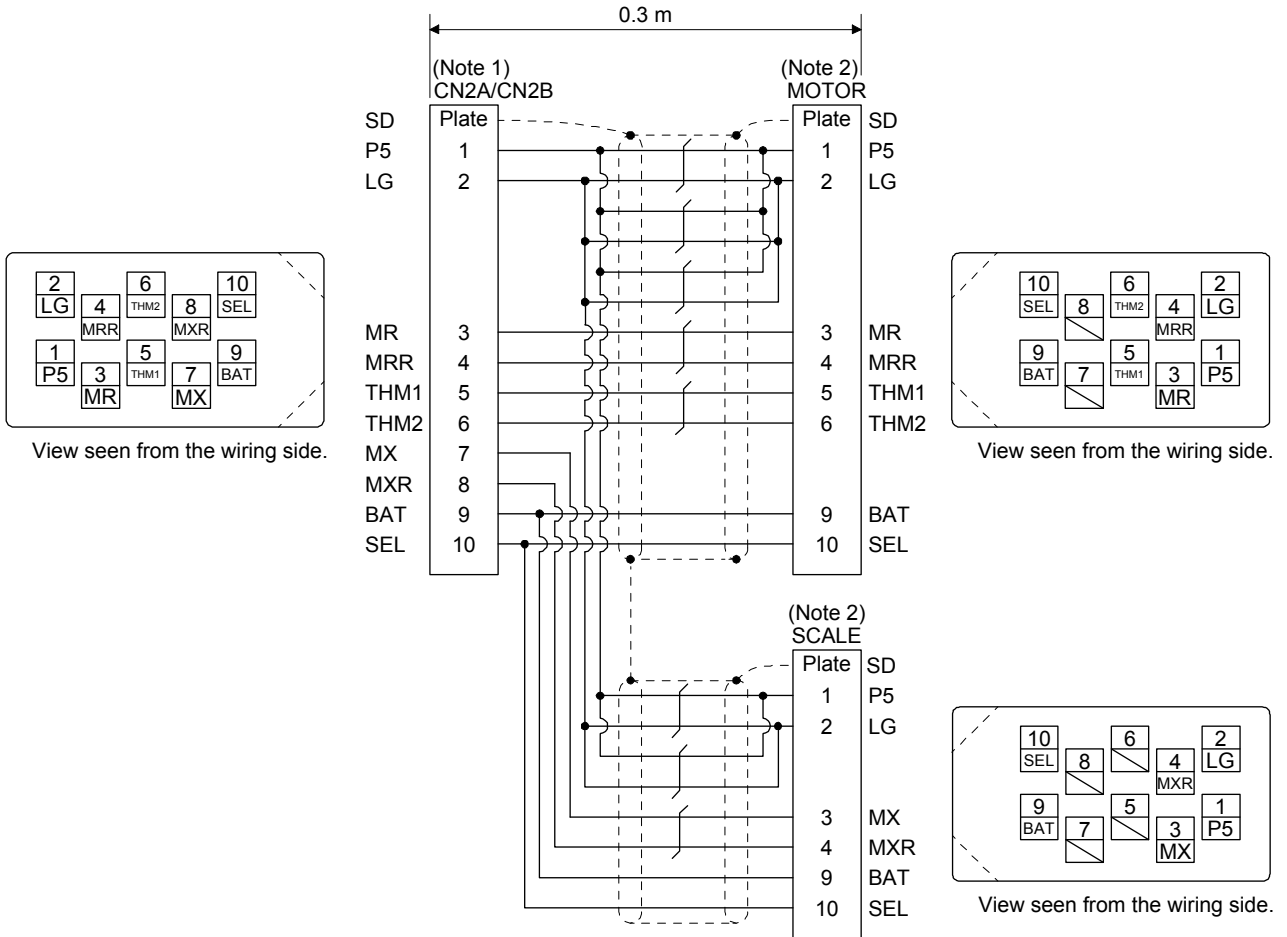

Note 1. Receptacle: 36210-0100PL, shell kit: 36310-3200-008 (3M)

Note 2. Plug: 36110-3000FD, shell kit: 36310-F200-008 (3M)

17. APPLICATION OF FUNCTIONS

17.2.3 How to use scale measurement function

(1) Selection of scale measurement function

The scale measurement function is set with the combination of basic setting parameters [Pr. PA01] and [Pr. PA22].

(1) Operation mode selection

The scale measurement function can be used during semi closed loop system (standard control mode). Set [Pr. PA01] to " __ 0 _".

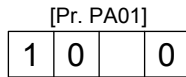

Operation mode selection

| Setting value | Operation mode | Control unit |
|---------------|----------------------------------------------------|-------------------------------------|
| 0 | Semi closed loop system (standard control mode) | Servo motor-side resolution unit |

(b) Scale measurement function selection

Select the scale measurement function. Select "1 __ __" (Used in absolute position detection system) or "2 __ __" (Used in incremental system) according to the encoder you use.

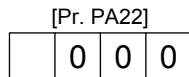

Scale measurement function selection

0: Disabled

1: Used in absolute position detection system

2: Used in incremental system

(2) Selection of scale measurement encoder polarity

Select a polarity of the scale measurement encoder with the following "Encoder pulse count polarity selection" of [Pr. PC27] as necessary.

| | |
|-------|-------------------------------------------------------------------------------------------------------------------------------------------------------------------------------------------------------------------------------------------------|
| POINT | <p>● "Encoder pulse count polarity selection" in [Pr. PC27] is not related to [Pr. PA14 Rotation direction selection]. Make sure to set the parameter according to the relationships between servo motor and linear encoder/rotary encoder.</p> |
|-------|-------------------------------------------------------------------------------------------------------------------------------------------------------------------------------------------------------------------------------------------------|

17. APPLICATION OF FUNCTIONS

(a) Parameter setting method

Selection of the encoder pulse count polarity

This parameter is used to set the load-side encoder polarity to be connected to CN2L connector in order to match the CCW direction of servo motor and the increasing direction of load-side encoder feedback. Set this as necessary.

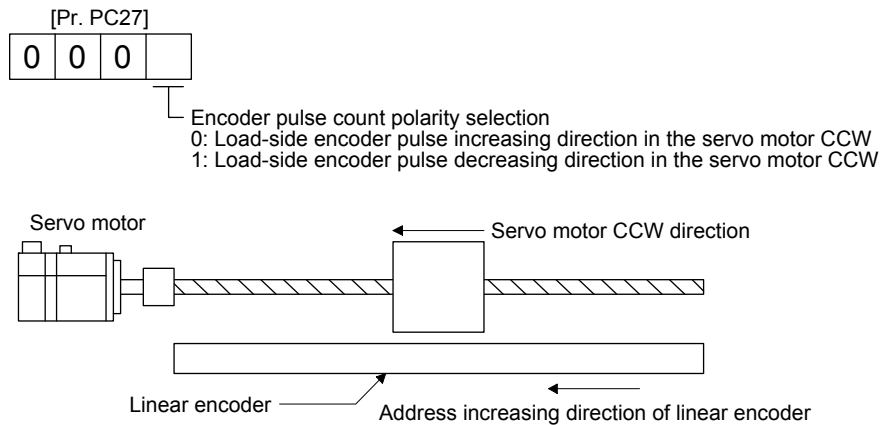

(b) How to confirm the scale measurement encoder feedback direction

You can confirm the directions of the cumulative feedback pulses of servo motor encoder and the load-side cumulative feedback pulses are matched by moving the device (scale measurement encoder) manually in the servo-off status. If mismatched, reverse the polarity.

(3) Confirmation of scale measurement encoder position data

Check the scale measurement encoder mounting and parameter settings for any problems.

Operate the device (scale measurement encoder) to check the data of the scale measurement encoder is renewed correctly. If the data is not renewed correctly, check the wiring and parameter settings.

Change the scale polarity as necessary.

18. MR-J4W2-0303B6 SERVO AMPLIFIER

18. MR-J4W2-0303B6 SERVO AMPLIFIER

The items in the following table are the same as those for MR-J4W2-_B and MR-J4W3-_B servo amplifiers. Refer to the section of the detailed explanation field for details.

| Item | Detailed explanation |
|------------------------------------|----------------------|
| Parameter | Chapter 5 |
| Normal gain adjustment | Chapter 6 |
| Special adjustment functions | Chapter 7 |
| Troubleshooting | Chapter 8 |
| Absolute position detection system | Chapter 12 |

18.1 Functions and configuration

18.1.1 Summary

MR-J4W2-0303B6 servo amplifier is MELSERVO-J4W-_B series 48 V DC and 24 V DC power compatible ultra small capacity servo amplifier.

The MR-J4W-_B servo amplifier is connected to controllers, including a servo system controller, on the fast synchronization network SSCNET III/H. The servo amplifier directly receives a command from a controller to drive a servo motor.

As the same as MR-J4W-_B servo amplifier, this servo amplifier supports the one-touch tuning and the real-time auto tuning. This enables you to easily adjust the servo gain according to the machine.

On the SSCNET III/H network, the stations are connected with a maximum distance of 100 m between them. This allows you to create a large system.

The following shows the difference between this amplifier and MR-J4W-_B.

| Category | Item | Differences | | Related parameter |
|--------------------------|-----------------------------------------|-------------------------|------------------------------------|--------------------------------------------------|
| | | MR-J4W-_B | MR-J4W2-0303B6 | |
| Power supply | Main circuit power supply | 200 V AC | 48 V DC/24 V DC | [Pr. PC05] ([Pr. Po04] in J3 compatibility mode) |
| | Control circuit power supply | 200 V AC | 24 V DC | |
| The number of drive axes | Number of axes | 2 axes/3 axes | 2 axes | |
| Functional safety | STO function | Compatible | | |
| Encoder | Encoder resolution | 4194304 pulses/rev | 262144 pulses/rev | |
| Regenerative option | Regenerative option selection | Compatible | | [Pr. PA02] |
| Analog monitor output | Output voltage range | | 10 V ± 5 V | [Pr. PC09]/[Pr. PC10] |
| Dynamic brake | Stop system | Stop with dynamic brake | Stop with electronic dynamic brake | [Pr. PF06]/[Pr. PF12] |
| Operation mode | Fully closed loop control mode | Compatible | | [Pr. PA01] |
| | Linear servo motor control mode | Compatible | | |
| | DD motor control mode | Compatible | | |
| Function | SEMI-F47 function | Compatible | | [Pr. PA20]/[Pr. PF25]/[Pr. PX23] |
| | Instantaneous power failure tough drive | Compatible | | |
| | Scale measurement function | Compatible | | [Pr. PA22] |

18. MR-J4W2-0303B6 SERVO AMPLIFIER

18.1.2 Function block diagram

The function block diagram of this servo is shown below.

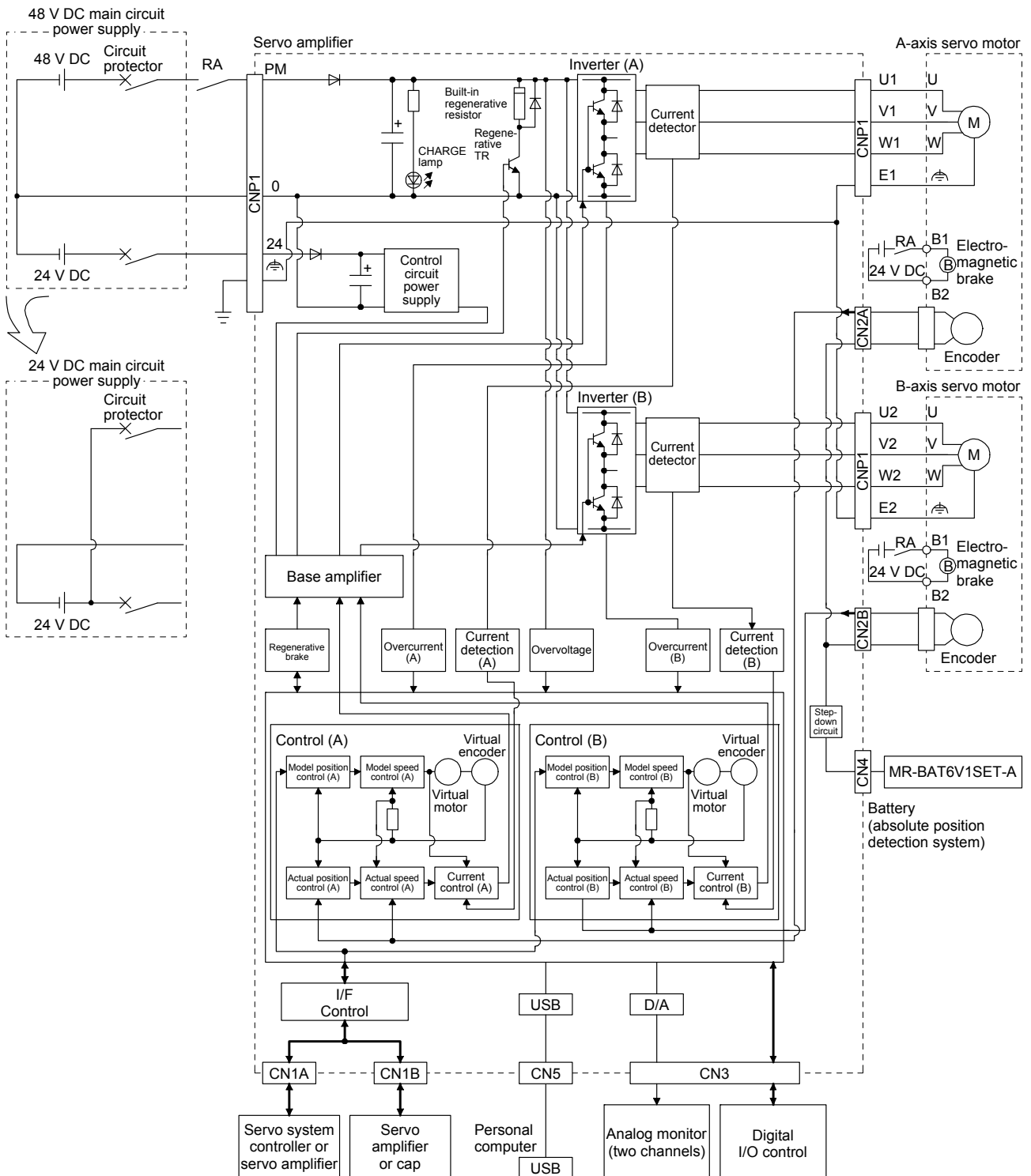

18. MR-J4W2-0303B6 SERVO AMPLIFIER

18.1 3 Servo amplifier standard specifications

| Model | | MR-J4W2-0303B6 |
|--------------------------------------------------------------------------------------|-------------------------------------------------------------------------------------------------------------------------------------------------|------------------------------------------------------------------------------------------------------------------------------------------------------------------------------------------------------------------------------------------------------------------------------------------------------------------|
| Rated output | | 30 W (A axis) + 30 W (B axis) |
| Output | Rated voltage | 3-phase 13 V AC |
| | Rated current (each axis) | 2.4 A |
| Main circuit power supply input | Voltage | 48 V DC/24 V DC (Note 1) |
| | Rated current | For 48 V DC: 2.4 A For 24 V DC: 4.8 A |
| | Permissible voltage fluctuation | For 48 V DC: 40.8 V DC to 55.2 V DC For 24 V DC: 21.6 V DC to 26.4 V DC |
| | Power supply capacity | Refer to section 18.7.2. |
| | Inrush current | Refer to section 18.7.4. |
| Control circuit power supply | Voltage | 24 V DC |
| | Rated current [A] | 0.5 A |
| | Permissible voltage fluctuation | 21.6 V DC to 26.4 V DC |
| | Power consumption [W] | 10 W |
| | Inrush current [A] | Refer to section 18.7.4. |
| Interface power supply | Voltage | 24 V DC \pm 10% |
| | Current capacity [A] | 0.25 (Note 2) |
| Capacitor regeneration | Reusable regenerative energy (Note 6) [J] | 0.9 |
| | Moment of inertia J of rotary servo motor equivalent to the permissible charging amount (Note 7) [$\times 10^{-4}$ kg \cdot m ²] | 0.18 |
| Control method | | Sine-wave PWM control, current control method |
| Permissible regenerative power of servo amplifier built-in regenerative resistor [W] | | 1.3 |
| Dynamic brake (Note 3) | | Built-in (electronic dynamic brake) |
| SSCNET III/H command communication cycle (Note 4) | | 0.222 ms, 0.444 ms, 0.888 ms |
| Communication function | | USB: connection to a personal computer or others (MR Configurator2-compatible) |
| Encoder output pulses | A/B-phase | Compatible |
| | Z-phase | Not compatible |
| Analog monitor | | Two channels |
| Protective functions | | Overcurrent shut-off, regenerative overvoltage shut-off, overload shut-off (electronic thermal), servo motor overheat protection, encoder error protection, regenerative error protection, undervoltage protection, instantaneous power failure protection, overspeed protection, and error excessive protection |
| Compliance with global standards | CE marking | LVD: EN 61800-5-1/EN 60950-1 EMC: EN 61800-3 |
| | UL standard | UL 508C (NMMS2) |
| Structure (IP rating) | | Natural cooling, open (IP20) |
| Close mounting | | Possible (Note 5) |
| DIN rail mounting (width: 35 mm) | | Possible |

18. MR-J4W2-0303B6 SERVO AMPLIFIER

| Model | | MR-J4W2-0303B6 | | |
|----------------------|---------------------|--------------------------------------------------------------------------|-----------------------------------------------------------------------------------|--|
| Environment | Ambient temperature | Operation | 0 °C to 55 °C (non-freezing) | |
| | | Storage | -20 °C to 65 °C (non-freezing) | |
| | Ambient humidity | Operation | 5 %RH to 90 %RH (non-condensing) | |
| | | Storage | | |
| | Ambience | | Indoors (no direct sunlight); no corrosive gas, inflammable gas, oil mist or dust | |
| | Altitude | | 1000 m or less above sea level | |
| Vibration resistance | | 5.9 m/s ² , at 10 Hz to 55 Hz (directions of X, Y and Z axes) | | |
| Mass | | [kg] | 0.3 | |

- Note
1. Initial value is the 48 V DC. For 24 V DC, set [Pr. PC05] to "_ 1 _". The characteristics of the servo motor vary depending on whether 48 V DC or 24 V DC is used. For details, refer to "Servo Motor Instruction Manual (Vol. 3)".
 2. 0.25 A is the value applicable when all I/O signals are used. The current capacity can be decreased by reducing the number of I/O points.
 3. This is an electronic dynamic brake. This will not operate during control circuit power supply off. In addition, It may not operate depending on the contents of alarms and warnings. Refer to chapter 8 for details.
 4. The communication cycle depends on the controller specifications and the number of axes connected.
 5. When closely mounting the servo amplifiers, operate them at the ambient temperatures of 45 °C or lower, or the total effective load ratio of 45 w or lower for the two axes.
 6. Regenerative energy is generated when the machine, whose moment of inertia is equivalent to the permissible charging amount, decelerates from the rated speed to stop.
 7. This is moment of inertia when the motor decelerates from the rated speed to stop. This will be moment of inertia for two axes when two motors decelerate simultaneously. And this will be moment of inertia for each axis when multiple motors do not decelerate simultaneously.

18.1.4 Combinations of servo amplifiers and servo motors

| Servo amplifier | Servo motor |
|-----------------|-------------|
| MR-J4W2-0303B6 | HG-AK0136 |
| | HG-AK0236 |
| | HG-AK0336 |

18. MR-J4W2-0303B6 SERVO AMPLIFIER

18.1.5 Function list

The following table lists the functions of MR-J4W2-0303B6 servo amplifier. For details of the functions, refer to each section indicated in the detailed explanation field.

| Function | Description | Detailed explanation |
|-------------------------------------------|----------------------------------------------------------------------------------------------------------------------------------------------------------------------------------------------------------------------------------------------------------------------------------------------------------------------------|--------------------------|
| Model adaptive control | This realizes a high response and stable control following the ideal model. The two-degree-of-freedom-model model adaptive control enables you to set a response to the command and response to the disturbance separately. Additionally, this function can be disabled. Refer to section 7.5 for disabling this function. | |
| Position control mode | This servo amplifier is used as a position control servo. | |
| Speed control mode | This servo amplifier is used as a speed control servo. | |
| Torque control mode | This servo amplifier is used as a torque control servo. | |
| High-resolution encoder | High-resolution encoder of 262144 pluses/rev is used for the encoder of the rotary servo motor compatible with the MR-J4W2-0303B6 servo amplifier. | |
| Absolute position detection system | Setting a home position once makes home position return unnecessary at every power-on. | Chapter 12 |
| Gain switching function | Using an input device or gain switching conditions (including the servo motor speed) switches gains. | Section 7.2 |
| Advanced vibration suppression control II | This function suppresses vibration at the arm end or residual vibration of the machine. | Section 7.1.5 |
| Machine resonance suppression filter | This is a filter function (notch filter) which decreases the gain of the specific frequency to suppress the resonance of the mechanical system. | Section 7.1.1 |
| Shaft resonance suppression filter | When a load is mounted to the servo motor shaft, resonance by shaft torsion during driving may generate a mechanical vibration at high frequency. The shaft resonance suppression filter suppresses the vibration. | Section 7.1.3 |
| Adaptive filter II | Servo amplifier detects mechanical resonance and sets filter characteristics automatically to suppress mechanical vibration. | Section 7.1.2 |
| Low-pass filter | Suppresses high-frequency resonance which occurs as servo system response is increased. | Section 7.1.4 |
| Machine analyzer function | Analyzes the frequency characteristic of the mechanical system by simply connecting an MR Configurator2 installed personal computer and servo amplifier. MR Configurator2 is necessary for this function. | |
| Robust filter | This function provides better disturbance response in case low response level that load to motor inertia ratio is high for such as roll send axes. | [Pr. PE41] |
| Slight vibration suppression control | Suppresses vibration of ± 1 pulse generated at a servo motor stop. | [Pr. PB24] |
| Auto tuning | Automatically adjusts the gain to optimum value if load applied to the servo motor shaft varies. | Chapter 6 |
| Regenerative option | This is not available with MR-J4W2-0303B6 servo amplifier. | |
| Alarm history clear | Alarm history is cleared. | [Pr. PC21] |
| Output signal selection (device settings) | The output devices including ALM (Malfunction) and INP (In-position) can be assigned to specified pins of the CN3 connector. | [Pr. PD07] to [Pr. PD09] |
| Output signal (DO) forced output | Output signal can be forced on/off independently of the servo status. Use this function for checking output signal wiring, etc. | Section 4.5.1 (1) (d) |
| Test operation mode | Jog operation, positioning operation, motor-less operation, DO forced output, and program operation MR Configurator2 is necessary for this function. | Section 4.5 |
| Analog monitor output | Servo status is outputted in terms of voltage in real time. | Section 5.2.3 |
| MR Configurator2 | Using a personal computer, you can perform the parameter setting, test operation, monitoring, and others. | Section 11.4 |
| Linear servo system | This is not available with MR-J4W2-0303B6 servo amplifier. | |
| Direct drive servo system | This is not available with MR-J4W2-0303B6 servo amplifier. | |
| One-touch tuning | One click on a certain button on MR Configurator2 adjusts the gains of the servo amplifier. MR Configurator2 is necessary for this function. | Section 6.2 |
| SEMI-F47 function | This is not available with MR-J4W2-0303B6 servo amplifier. | |

18. MR-J4W2-0303B6 SERVO AMPLIFIER

| Function | Description | Detailed explanation |
|---------------------------------------------|---------------------------------------------------------------------------------------------------------------------------------------------------------------------------------------------------------------------------------------------------------------------------------------------------------------------------------------------------------------------------------------------------------------------------------------------------------------------------------------------------------------------------------------------------------------------------------------------------------------------------|---------------------------------------------------|
| Tough drive function | This function makes the equipment continue operating even under the condition that an alarm occurs. MR-J4W2-0303B6 servo amplifier is compatible with vibration tough drive. This is not compatible with instantaneous power failure tough drive. | Section 7.3 |
| Drive recorder function | This function continuously monitors the servo status and records the status transition before and after an alarm for a fixed period of time. You can check the recorded data on the drive recorder window on MR Configurator2 by clicking the "Graph" button. However, the drive recorder will not operate on the following conditions. 1. You are using the graph function of MR Configurator2. 2. You are using the machine analyzer function. 3. [Pr. PF21] is set to "-1". 4. The controller is not connected (except the test operation mode). 5. An alarm related to the controller is occurring. | [Pr. PA23] |
| STO function | This is not available with MR-J4W2-0303B6 servo amplifier. | |
| Servo amplifier life diagnosis function | Cumulative operation time can be checked. This function get hold of the replacement time for parts of the servo amplifier including a capacitor before it malfunctions. MR Configurator2 is necessary for this function. | |
| Power monitoring function | This function calculates the power running energy and the regenerative power from the data in the servo amplifier such as speed and current. Power consumption and others are displayed on MR Configurator2. Since the servo amplifier sends data to a servo system controller, you can analyze the data and display the data on a display with the SSCNET III/H system. | |
| Machine diagnosis function | From the data in the servo amplifier, this function estimates the friction and vibrational component of the drive system in the equipment and recognizes an error in the machine parts, including a ball screw and bearing. MR Configurator2 is necessary for this function. | |
| Fully closed loop system | This is not available with MR-J4W2-0303B6 servo amplifier. | |
| Scale measurement function | This is not available with MR-J4W2-0303B6 servo amplifier. | |
| J3 compatibility mode | This amplifier has "J3 compatibility mode" which compatible with the previous MR-J3-B series. Refer to section 17.1 for software versions. | Section 17.1 |
| Continuous operation to torque control mode | This enables to smoothly switch the mode from position control mode/speed control mode to torque control mode without stopping. This also enables to decrease load to the machine and high quality molding without rapid changes in speed or torque. For details of the continuous operation to torque control mode, refer to the manuals for servo system controllers. | [Pr. PB03] Manual of servo system controllers. |

18. MR-J4W2-0303B6 SERVO AMPLIFIER

18.1.6 Model definition

(1) Rating plate

The following shows an example of rating plate for explanation of each item.

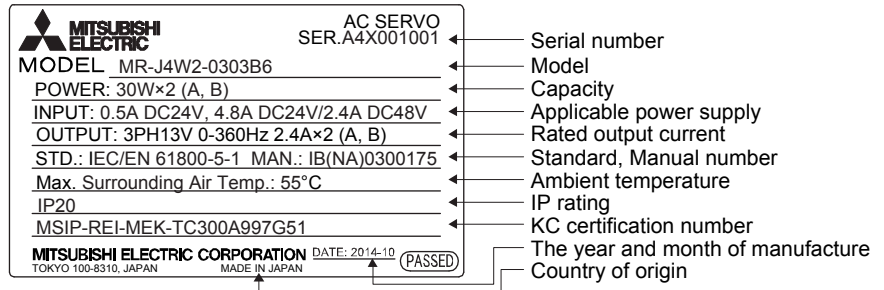

(2) Model

The following describes what each block of a model name indicates. Not all combinations of the symbols are available.

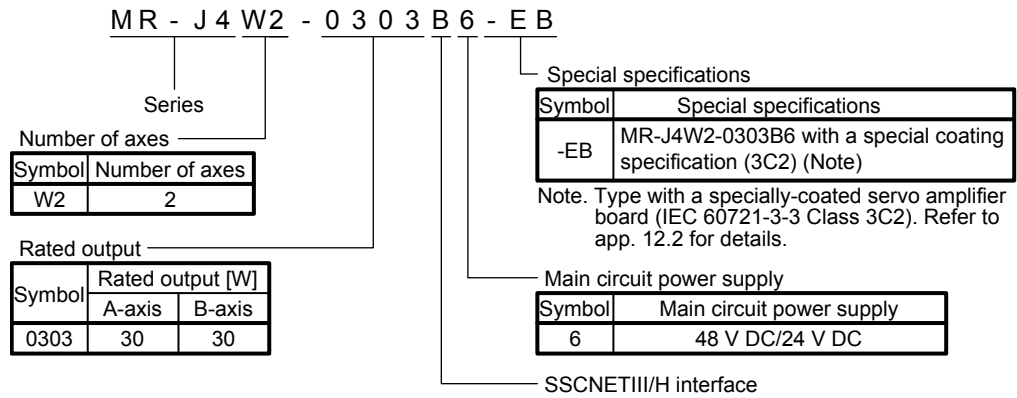

18. MR-J4W2-0303B6 SERVO AMPLIFIER

18.1.7 Parts identification

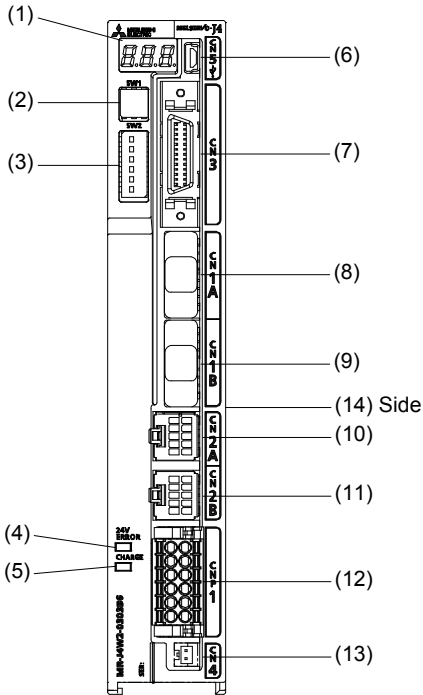

| No. | Name/Application | Detailed explanation | | | | | | | | | | | | | | | | | | | | | | | | |
|------------|-----------------------------------------------------------------------------------------------------------------------------------------------------------------------------------------------------------------------------------------------------------------------------------------------------------------------------------------------------------------------------------------------------------------------------------------------------------------------------------------------------------------------------------------------------------------------------------------------------------------------------------------------------------------------------------------------------------------------------------------------------------------------------------------------------------------------------------------------------------------------------------------------------------------------------------------------------------------------------------------------------------------------------------------------------|----------------------------------|----|---|----|---|----|---|----|---|----|---|----|---|------------------------------|---|------------------------------------------|---|------------------------------------------|---|--------------------------|---|--------------------------------------|---|--------------------------------------|--------------|
| (1) | Display The 3-digit, 7-segment LED shows the servo status and the alarm number. | Section 18.5 | | | | | | | | | | | | | | | | | | | | | | | | |
| (2) | Axis selection rotary switch (SW1) Set the axis No. of the servo amplifier. | Section 18.5 | | | | | | | | | | | | | | | | | | | | | | | | |
| (3) | Control axis setting switch (SW2) The test operation switch, the disabling control axis switch, and the auxiliary axis number setting switch are available. <div style="display: flex; align-items: center;"> <div style="border: 1px solid black; padding: 2px; margin-right: 10px;"> <table style="font-size: 8px; border-collapse: collapse;"> <tr><td>1</td><td>ON</td></tr> <tr><td>2</td><td>ON</td></tr> <tr><td>3</td><td>ON</td></tr> <tr><td>4</td><td>ON</td></tr> <tr><td>5</td><td>ON</td></tr> <tr><td>6</td><td>ON</td></tr> </table> </div> <div> <table style="font-size: 8px; border-collapse: collapse;"> <tr><td>1</td><td>Test operation select switch</td></tr> <tr><td>2</td><td>Disabling control axis switch for A-axis</td></tr> <tr><td>3</td><td>Disabling control axis switch for B-axis</td></tr> <tr><td>4</td><td>For manufacturer setting</td></tr> <tr><td>5</td><td>Auxiliary axis number setting switch</td></tr> <tr><td>6</td><td>Auxiliary axis number setting switch</td></tr> </table> </div> </div> | 1 | ON | 2 | ON | 3 | ON | 4 | ON | 5 | ON | 6 | ON | 1 | Test operation select switch | 2 | Disabling control axis switch for A-axis | 3 | Disabling control axis switch for B-axis | 4 | For manufacturer setting | 5 | Auxiliary axis number setting switch | 6 | Auxiliary axis number setting switch | Section 18.5 |
| 1 | ON | | | | | | | | | | | | | | | | | | | | | | | | | |
| 2 | ON | | | | | | | | | | | | | | | | | | | | | | | | | |
| 3 | ON | | | | | | | | | | | | | | | | | | | | | | | | | |
| 4 | ON | | | | | | | | | | | | | | | | | | | | | | | | | |
| 5 | ON | | | | | | | | | | | | | | | | | | | | | | | | | |
| 6 | ON | | | | | | | | | | | | | | | | | | | | | | | | | |
| 1 | Test operation select switch | | | | | | | | | | | | | | | | | | | | | | | | | |
| 2 | Disabling control axis switch for A-axis | | | | | | | | | | | | | | | | | | | | | | | | | |
| 3 | Disabling control axis switch for B-axis | | | | | | | | | | | | | | | | | | | | | | | | | |
| 4 | For manufacturer setting | | | | | | | | | | | | | | | | | | | | | | | | | |
| 5 | Auxiliary axis number setting switch | | | | | | | | | | | | | | | | | | | | | | | | | |
| 6 | Auxiliary axis number setting switch | | | | | | | | | | | | | | | | | | | | | | | | | |
| (4) | Control circuit power voltage error lamp (24 V ERROR) When a voltage of the control circuit power voltage (24 V DC) is out of permissible range, this will light in yellow. | Section 18.4.3 | | | | | | | | | | | | | | | | | | | | | | | | |
| (5) | Charge lamp (CHARGE) When the main circuit is charged, this will light up. While this lamp is lit, do not reconnect the cables. | / | | | | | | | | | | | | | | | | | | | | | | | | |
| (6) | USB communication connector (CN5) Connect the personal computer. | Section 11.4 | | | | | | | | | | | | | | | | | | | | | | | | |
| (7) | I/O signal connector (CN3) Used to connect digital I/O signals. | Section 18.3.5 Section 18.3.6 | | | | | | | | | | | | | | | | | | | | | | | | |
| (8) | SSCNET III cable connector (CN1A) Used to connect the servo system controller or the previous axis servo amplifier. | Section 18.3.5 | | | | | | | | | | | | | | | | | | | | | | | | |
| (9) | SSCNET III cable connector (CN1B) Used to connect the next axis servo amplifier. For the final axis, put a cap. | Section 18.3.6 | | | | | | | | | | | | | | | | | | | | | | | | |
| (10) | A-axis encoder connector (CN2A) Used to connect the A-axis servo motor encoder. | Section 18.3.1 | | | | | | | | | | | | | | | | | | | | | | | | |
| (11) | B-axis encoder connector (CN2B) Used to connect the B-axis servo motor encoder. | Section 18.3.2 | | | | | | | | | | | | | | | | | | | | | | | | |
| (12) | Power and servo motor power output connector (CNP1) Used to connect input power and servo motor power output line. | Section 18.3.1 Section 18.3.2 | | | | | | | | | | | | | | | | | | | | | | | | |
| (13) | Battery connector (CN4) Used to connect the battery for absolute position data backup. | Section 11.3 Chapter 12 | | | | | | | | | | | | | | | | | | | | | | | | |
| 14 or less | Rating plate | Section 18.1.6 (1) | | | | | | | | | | | | | | | | | | | | | | | | |

18. MR-J4W2-0303B6 SERVO AMPLIFIER

18.1.8 Configuration including peripheral equipment

CAUTION ● Wrong wiring to CNP1 connector or connecting an encoder of wrong axis to CN2A and CN2B may cause a malfunction.

POINT

● Equipment other than the servo amplifier and servo motor are optional or recommended products.

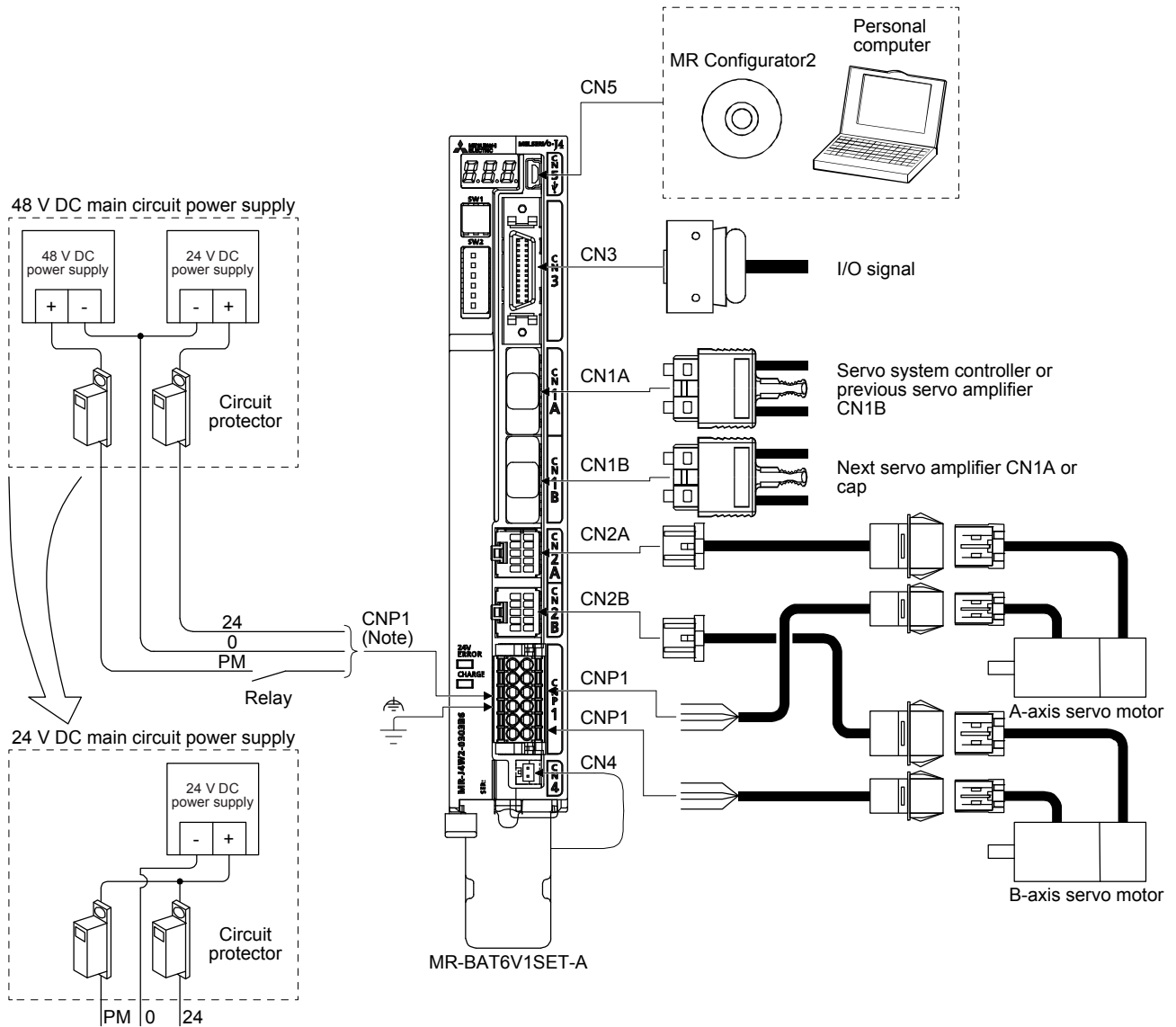

Note. Refer to section 18.3.2 for details.

18. MR-J4W2-0303B6 SERVO AMPLIFIER

18.2 Installation

⚠ WARNING ● To prevent electric shock, ground equipment securely.

- Stacking in excess of the specified number of product packages is not allowed.
- Install the equipment on incombustible material. Installing them directly or close to combustibles will lead to a fire.
- Install the servo amplifier and the servo motor in a load-bearing place in accordance with the Instruction Manual.
- Do not get on or put heavy load on the equipment. Otherwise, it may cause injury.
- Use the equipment within the specified environment. For the environment, refer to section 18.1.3.
- Provide an adequate protection to prevent screws and other conductive matter, oil and other combustible matter from entering the servo amplifier.
- Do not block the intake and exhaust areas of the servo amplifier. Otherwise, it may cause a malfunction.
- Do not drop or strike the servo amplifier. Isolate it from all impact loads.
- Do not install or operate the servo amplifier which has been damaged or has any parts missing.

- ⚠ CAUTION**
- When the equipment has been stored for an extended period of time, contact your local sales office.
 - When handling the servo amplifier, be careful about the edged parts such as corners of the servo amplifier.
 - The servo amplifier must be installed in a metal cabinet.
 - The equipment must be installed in the specified direction. Otherwise, it may cause a malfunction.
 - Leave specified clearances between the servo amplifier and the cabinet walls or other equipment. Otherwise, it may cause a malfunction.
 - When fumigants that contain halogen materials, such as fluorine, chlorine, bromine, and iodine, are used for disinfecting and protecting wooden packaging from insects, they cause malfunction when entering our products. Please take necessary precautions to ensure that remaining materials from fumigant do not enter our products, or treat packaging with methods other than fumigation, such as heat treatment. Additionally, disinfect and protect wood from insects before packing the products.

The items in the following table are the same as those for MR-J4W2-_B and MR-J4W3-_B servo amplifiers. Refer to the section of the detailed explanation field for details.

| Item | Detailed explanation |
|----------------------------|----------------------|
| Keep out foreign materials | Section 2.2 |
| Encoder cable stress | Section 2.3 |
| SSCNET III cable laying | Section 2.4 |
| Inspection items | Section 2.5 |
| Parts having service life | Section 2.6 |

18. MR-J4W2-0303B6 SERVO AMPLIFIER

18.2.1 Installation direction and clearances

When using heat generating equipment, install them with full consideration of heat generation so that the servo amplifier is not affected.

Install the servo amplifier on a perpendicular wall in the correct vertical direction.

(1) Installation of one servo amplifier

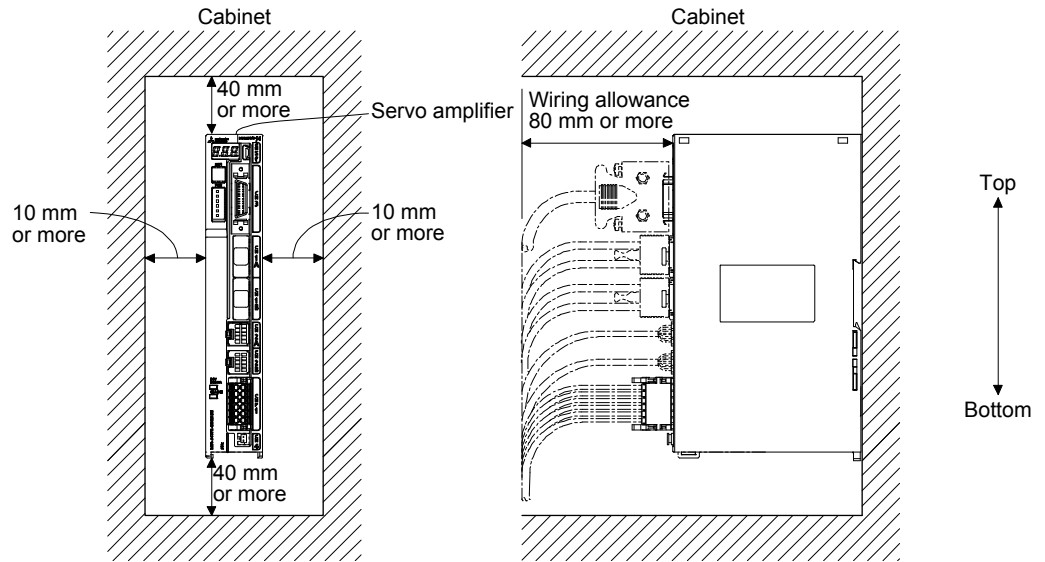

18. MR-J4W2-0303B6 SERVO AMPLIFIER

(2) Installation of two or more servo amplifiers

| POINT |
|-----------------------------------------------------------------------------------------------------------------------------------------------------------------------------------------------------------------------------------------------------------------|
| ● You can install MR-J4W2-0303B6 servo amplifiers without clearances between them. When closely mounting the servo amplifiers, operate them at the ambient temperatures of 45 °C or lower, or the total effective load ratio of 45 w or lower for the two axes. |

Leave a large clearance between the top of the servo amplifier and the cabinet walls, and install a cooling fan to prevent the internal temperature of the cabinet from exceeding the environmental conditions. When mounting the servo amplifiers closely, leave a clearance of 1 mm between the adjacent servo amplifiers in consideration of mounting tolerances.

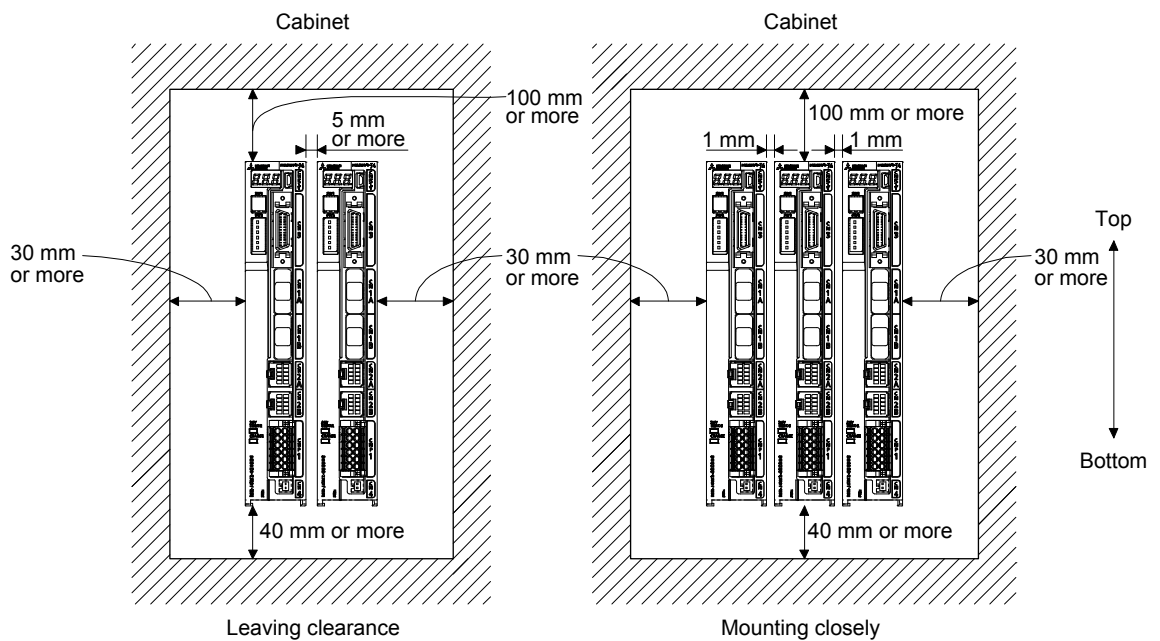

18. MR-J4W2-0303B6 SERVO AMPLIFIER

18.2.2 Installation by DIN rail

● To mount the servo amplifier to DIN rail, pull down the tab of hook. The hook may come off when the tab is pushed down from the back side of the servo amplifier.

CAUTION

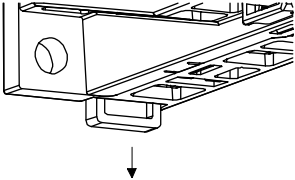

The following explains mounting and removing procedure of servo amplifier using DIN rail.

Mounting servo amplifier to DIN rail

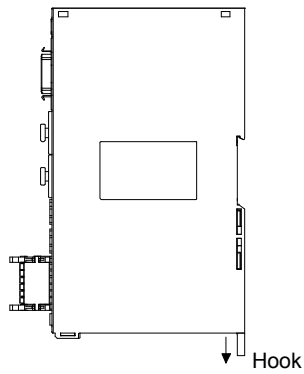

1) Pull down the hook.

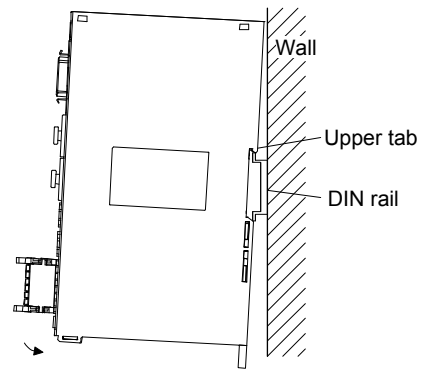

2) Hang the upper tab on the back of the servo amplifier to the upper tab of DIN rail, and push toward to the wall.

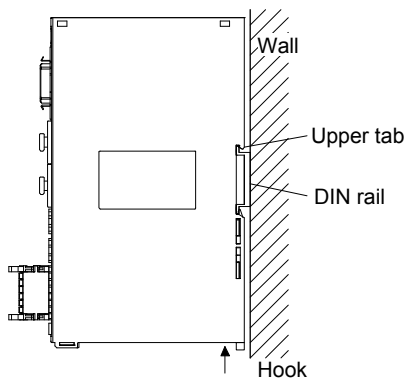

3) Push up the hook, and fix the servo amplifier.

18. MR-J4W2-0303B6 SERVO AMPLIFIER

Removing servo amplifier from DIN rail

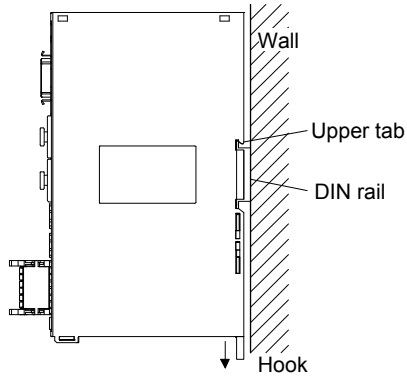

1) Pull down the hook.

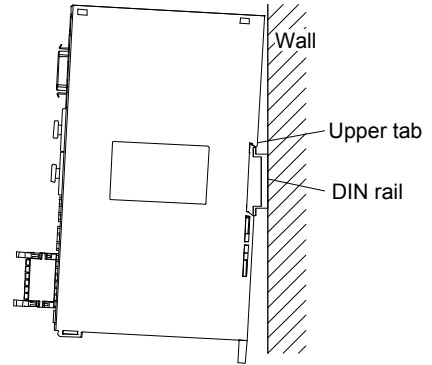

2) Pull the servo amplifier forward.

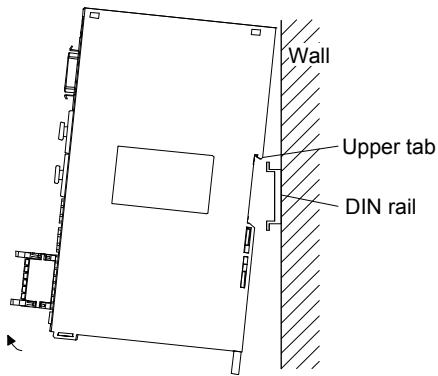

3) Lift up and remove the servo amplifier.

18. MR-J4W2-0303B6 SERVO AMPLIFIER

18.3 Signals and wiring

⚠ WARNING

- A person who is involved in wiring should be fully competent to do the work.
- Before wiring, turn off the power and check to see if the charge lamp turned off. Otherwise, an electric shock may occur. In addition, when confirming whether the charge lamp is off or not, always confirm it from the front of the servo amplifier.
- Ground the servo amplifier and servo motor securely.
- Do not attempt to wire the servo amplifier and servo motor until they have been installed. Otherwise, it may cause an electric shock.
- The cables should not be damaged, stressed, loaded, or pinched. Otherwise, it may cause an electric shock.

- Wire the equipment correctly and securely. Otherwise, the servo motor may operate unexpectedly, resulting in injury.
- Connect cables to the correct terminals. Otherwise, a burst, damage, etc. may occur.
- Ensure that polarity (+/-) is correct. Otherwise, a burst, damage, etc. may occur.
- The surge absorbing diode installed to the DC relay for control output should be fitted in the specified direction. Otherwise, the emergency stop and other protective circuits may not operate.

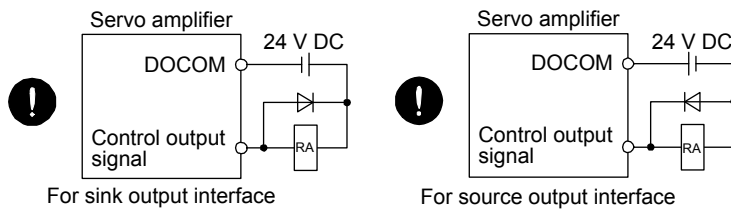

⚠ CAUTION

- Use a noise filter, etc. to minimize the influence of electromagnetic interference. Electromagnetic interference may be given to the electronic equipment used near the servo amplifier.
- Do not install a power capacitor, surge killer or radio noise filter (optional FR-BIF) with the power line of the servo motor.
- Do not modify the equipment.
- Connect the servo amplifier power output (U/V/W) to the servo motor power input (U/V/W) directly. Do not let a magnetic contactor, etc. intervene. Otherwise, it may cause a malfunction.

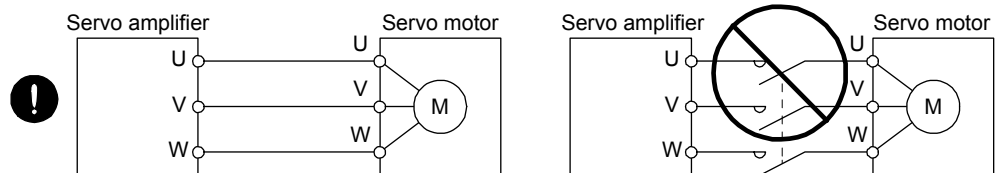

- Connecting a linear servo motor of the wrong axis to the CNP1 connector may cause a malfunction.

18. MR-J4W2-0303B6 SERVO AMPLIFIER

The items in the following table are the same as those for MR-J4W2-_B and MR-J4W3-_B servo amplifiers. Refer to the section of the detailed explanation field for details.

| Item | Detailed explanation |
|-------------------------------------------|----------------------|
| Forced stop deceleration function | Section 3.6 |
| SSCNET III cable connection | Section 3.9 |
| Servo motor with an electromagnetic brake | Section 3.10 |

18.3.1 Input power supply circuit

CAUTION

- Connect a circuit protector between the power supply and power supply voltage input terminals (24/PM) of the servo amplifier, in order to configure a circuit that shuts down the power supply on the side of the servo amplifier's power supply. If a circuit protector is not connected, continuous flow of a large current may cause a fire when the servo amplifier malfunctions.
- When alarms are occurring in both axes of A and B, shut off the main circuit power supply. Not doing so may cause a fire when a regenerative transistor malfunctions or the like may overheat the built-in regenerative resistor.
- Check the servo amplifier model, and then input proper voltage to the servo amplifier power supply. If input voltage exceeds the upper limit of the specification, the servo amplifier will break down.
- Connecting a servo motor of the wrong axis to the CNP1 connector may cause a malfunction.

POINT

- Even if alarm has occurred, do not switch off the control circuit power supply. When the control circuit power supply has been switched off, optical module does not operate, and optical transmission of SSCNET III/H communication is interrupted. Therefore, the next axis servo amplifier displays "AA" at the indicator and turns into base circuit shut-off. The servo motor stops with starting dynamic brake.
- EM2 has the same function as EM1 in the torque control mode.

Configure the wiring so that the main circuit power supply is shut off and the servo-on command turned off after deceleration to a stop due to an alarm occurring, an enabled servo forced stop, or an enabled controller forced stop.

18. MR-J4W2-0303B6 SERVO AMPLIFIER

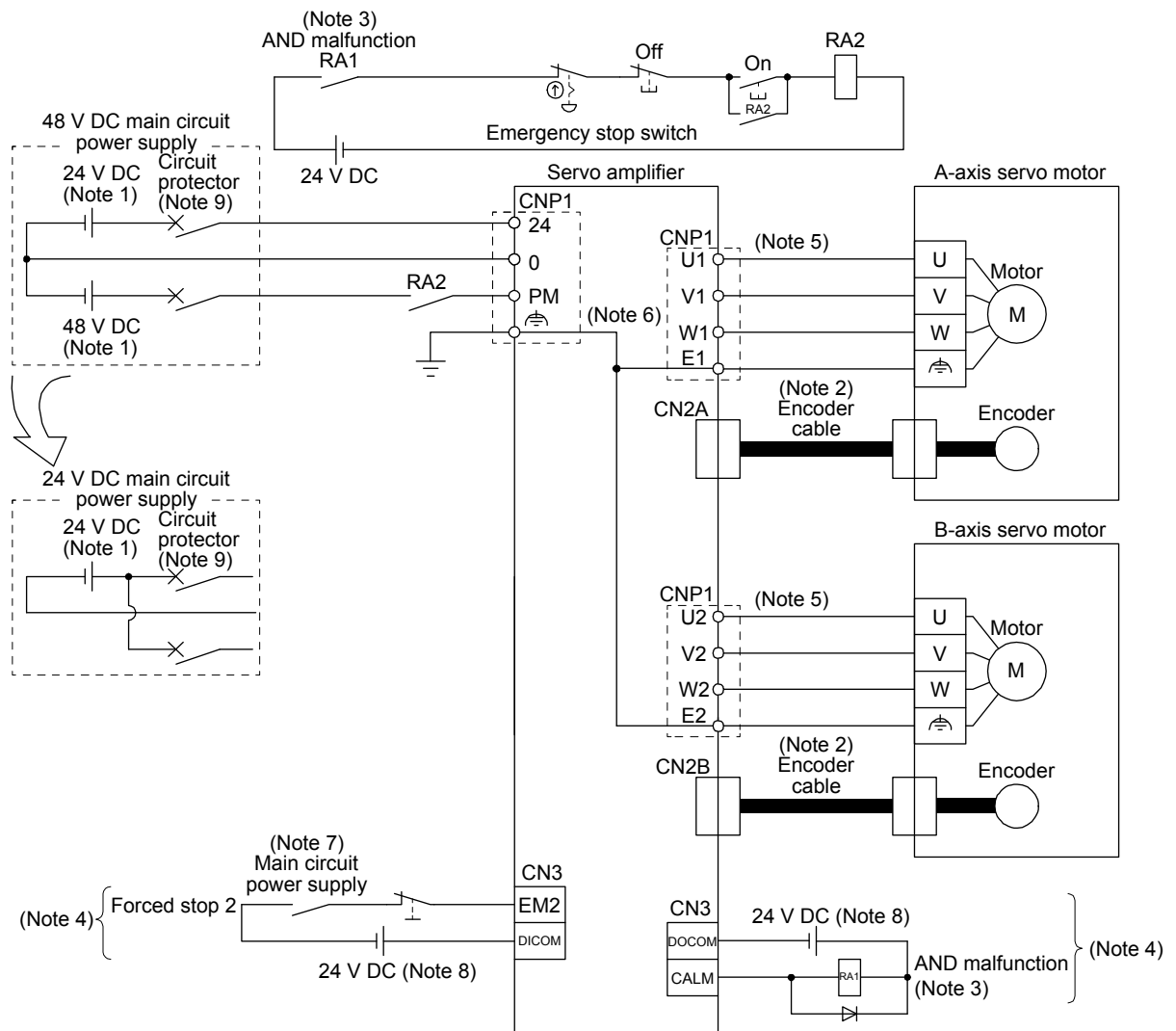

- Note 1. Use reinforced insulating type for 24 V DC and 48 V DC power supply.
- Note 2. For the encoder cable of the option cable is recommended. For selecting cables, refer to "Servo Motor Instruction Manual (Vol. 3)".
- Note 3. This circuit is an example of stopping all axes when an alarm occurs. If disabling CALM (AND malfunction) output with the parameter, configure the circuit which switches off the main circuit power supply after detection of alarm occurrence on the controller side.
- Note 4. This diagram shows sink I/O interface. For source I/O interface, refer to section 3.8.3.
- Note 5. For connecting servo motor power output lines, refer to "Servo Motor Instruction Manual (Vol. 3)". Connecting a wrong axis may cause a malfunction.
- Note 6. The noiseless grounding terminals ⏏ of E1 and E2 are connected in the servo amplifier. Be sure to ground from the noiseless grounding terminal of CNP1 to the grounding terminal ⏏ of the cabinet.
- Note 7. Configure a circuit to turn off EM2 when the main circuit power is turned off to prevent an unexpected restart of the servo amplifier.
- Note 8. The illustration of the 24 V DC power supply is divided between input signal and output signal for convenience. However, they can be configured by one.
For 24 V DC power for I/O signal, use power other than 24 V DC power of servo amplifier control circuit power supply.
- Note 9. Circuit protectors are required for protection of power supplies, wires, servo amplifiers and others. When not using a circuit protector, configure an external protective circuit such as a power supply with protection function.

18. MR-J4W2-0303B6 SERVO AMPLIFIER

18.3.2 Explanation of power supply system

(1) Pin assignment

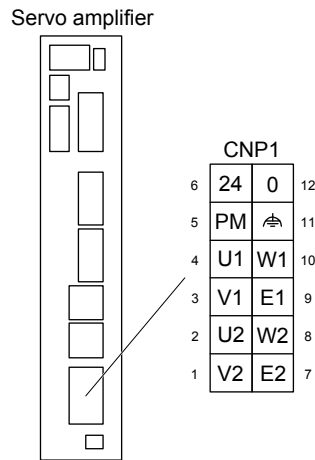

(2) Detailed explanation

| Symbol | Connection target (application) | Description | | | | | | | | | |
|---------------------------|-------------------------------------------|----------------------------------------------------------------------------------------------------------------------------------------------------------------------------------------------------------------------------------------------------------------------------------------------------------------------------------------------------------------------------------------------------------------------------------------------------------------------------------------------------|---------------------------|-----------|-------------------------------------------------|---------|--|-------------------------|---------|--|---------|
| 24 | | Used to connect + of the control circuit power supply (24 V DC). | | | | | | | | | |
| PM | Control circuit/main circuit power supply | Used to connect + of the main circuit power supply (48 V DC/24 V DC). Set [Pr. PC05] according to the specification of main circuit power supply. <table border="1" style="margin: 10px auto;"> <thead> <tr> <th>Main circuit power supply</th> <th>Parameter</th> <th>[Pr. PC05 function selection C-2] setting value</th> </tr> </thead> <tbody> <tr> <td>48 V DC</td> <td></td> <td>_ 0 _ _ (initial value)</td> </tr> <tr> <td>24 V DC</td> <td></td> <td>_ 1 _ _</td> </tr> </tbody> </table> | Main circuit power supply | Parameter | [Pr. PC05 function selection C-2] setting value | 48 V DC | | _ 0 _ _ (initial value) | 24 V DC | | _ 1 _ _ |
| Main circuit power supply | Parameter | [Pr. PC05 function selection C-2] setting value | | | | | | | | | |
| 48 V DC | | _ 0 _ _ (initial value) | | | | | | | | | |
| 24 V DC | | _ 1 _ _ | | | | | | | | | |
| 0 | | Switch off - of the control circuit power supply and main circuit power supply. | | | | | | | | | |
| ⏏ | Noiseless grounding | Connect to the grounding terminal of the cabinet to ground. | | | | | | | | | |
| U1/V1/W1/E1 | A-axis servo motor power output | Connect the servo amplifier power output (U1/V1/W1/E1) to the servo motor power input (U/V/W/⏏) directly. Do not let a magnetic contactor, etc. intervene. Otherwise, it may cause a malfunction. | | | | | | | | | |
| U2/V2/W2/E2 | B-axis servo motor power output | Connect the servo amplifier power output (U2/V2/W2/E2) to the servo motor power input (U/V/W/⏏) directly. Do not let a magnetic contactor, etc. intervene. Otherwise, it may cause a malfunction. | | | | | | | | | |

18. MR-J4W2-0303B6 SERVO AMPLIFIER

(3) Wiring CNP1

| | |
|----------------------------------------------------------------|--|
| POINT | |
| ● For the wire sizes used for wiring, refer to section 18.8.3. | |

(a) Connector

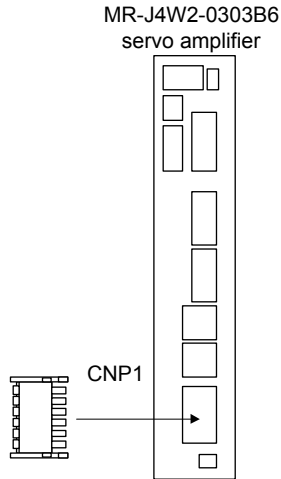

Table 18.1 Connector and applicable wire

| Connector | Receptacle assembly | Applicable wire size | Stripped length [mm] | Manufacturer |
|-----------|-------------------------------------|----------------------|----------------------|-----------------|
| CNP1 | DFMC 1,5/ 6-ST-3,5-LR or equivalent | AWG 24 to 16 | 10 | Phoenix Contact |

18. MR-J4W2-0303B6 SERVO AMPLIFIER

(b) Cable connection procedure

1) Fabrication on cable insulator

Refer to table 18.1 for stripped length of cable insulator. The appropriate stripped length of cables depends on their type, etc. Set the length considering their fabrication status.

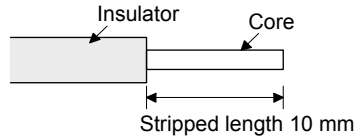

Twist strands lightly and straighten them as follows.

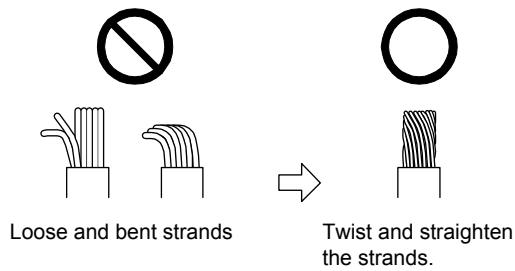

You can also use a ferrule to connect with the connectors. When you use a ferrule, use the following ferrules and crimp terminal.

| Wire size | Ferrule model (Phoenix Contact) | | Crimping tool (Phoenix Contact) |
|-----------|---------------------------------|---------|------------------------------------|
| | For one | For two | |
| AWG 20 | AI0.25-10YE | | CRIMPFOX6 |
| AWG 18 | AI0.34-10TQ | | |
| AWG 18 | AI0.5-10WH | | |
| AWG 16 | AI0.75-10GY | | |

2) Inserting wire

When using solid wire, insert the wire to the end. When using stranded wire, insert the wire to the end with pushing down the release button with a small flat head screwdriver, etc.

The following show a connection example when using stranded wire to the CNP 1 connector.

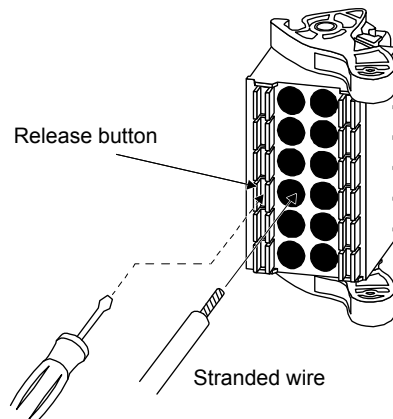

18. MR-J4W2-0303B6 SERVO AMPLIFIER

(c) Mounting connector

1) Mounting

Fit the CNP1 connector when the servo amplifier is fixed. While pushing the connector, make sure that the connector is locked to the top and bottom of the socket. After that, check that the connector cannot be pulled out.

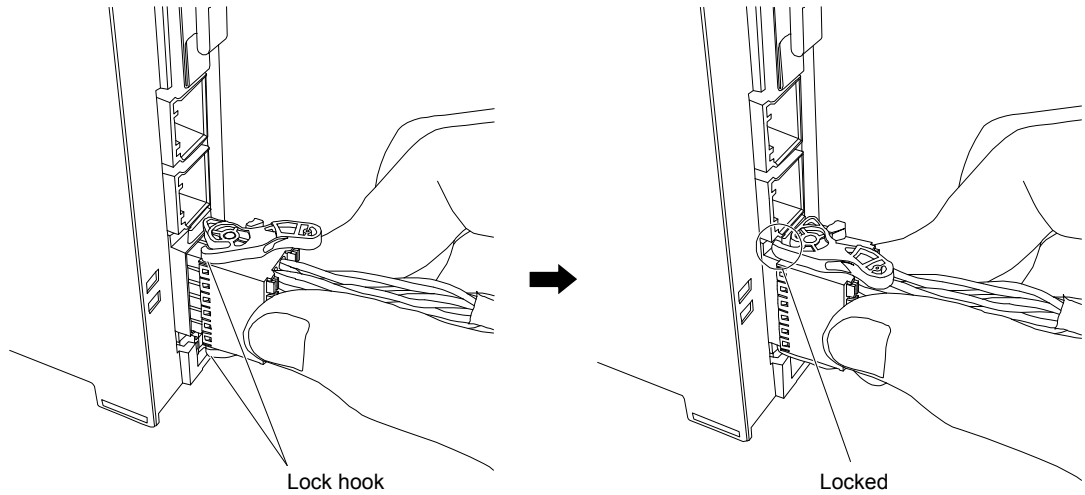

Refer to the following example for a status of lock.

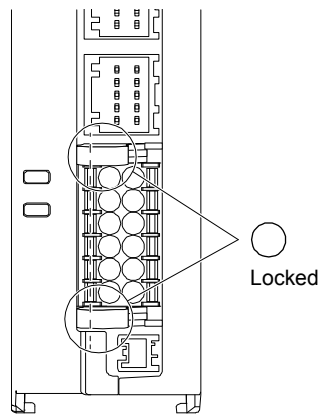

Good example
(Both are locked.)

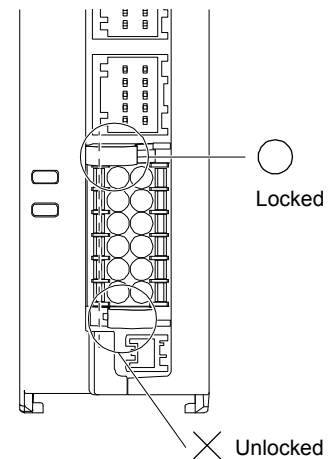

Bad example
(Bottom is not locked.)

2) Disconnection

Pull out the CNP1 connector after unlocking the top and bottom of the connector.

18. MR-J4W2-0303B6 SERVO AMPLIFIER

18.3.3 Selection of main circuit power supply/control circuit power supply

The inrush current at power on will be large because a resistance for protecting inrush current is not built-in in the main circuit power supply of the servo amplifier. The electric capacity of the main circuit capacitor is approximately 630 μ F. When the load characteristic (overcurrent protection criteria) of the power unit is current fold back method, the power cannot be started. Be careful when selecting a power. Especially when the power is turned ON/OFF on the power unit output side, approximately 100 μ s to 300 μ s instantaneous current will flow at power on due to capacitor charge. Therefore, a power unit such as one which operates overcurrent at 1 ms or less cannot be used.

A circuit to protect inrush current at power on is built-in in the control circuit power supply of servo amplifier. In addition, when using main circuit power supply and control circuit power supply, use a reinforced insulating type.

18.3.4 Power-on sequence

| POINT |
|--------------------------------------------------------------------------------------------------------------------------------------------|
| <ul style="list-style-type: none"> ● The voltage of analog monitor output, output signal, etc. may be unstable at power-on. |

(1) Power-on procedure

- 1) When wiring the power supply, use a circuit protector for the power supply (24/PM). Configure up an external sequence so that the relay connected to PM turns off when an alarm occurs in both axes of A and B.
- 2) Switch on the control circuit power supply (24/0) simultaneously with the main circuit power supply (PM/0) or before switching on the main circuit power supply. If the control circuit power supply is turned on with the main circuit power supply off, and then the servo-on command is transmitted, [AL. E9 Main circuit off warning] will occur. Turning on the main circuit power supply stops the warning and starts the normal operation.
- 3) The servo amplifier receives the servo-on command within 4 s after the main circuit power supply is switched on.
(Refer to (2) in this section.)

(2) Timing chart

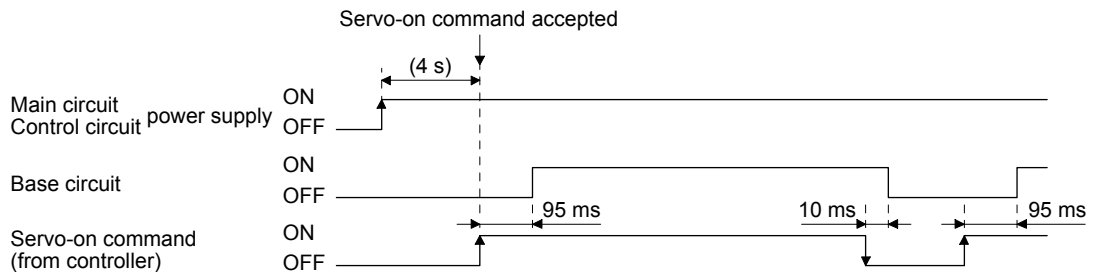

18. MR-J4W2-0303B6 SERVO AMPLIFIER

18.3.5 I/O Signal Connection Example

| |
|---------------------------------------------------------------|
| POINT |
| ●EM2 has the same function as EM1 in the torque control mode. |

(1) For sink I/O interface

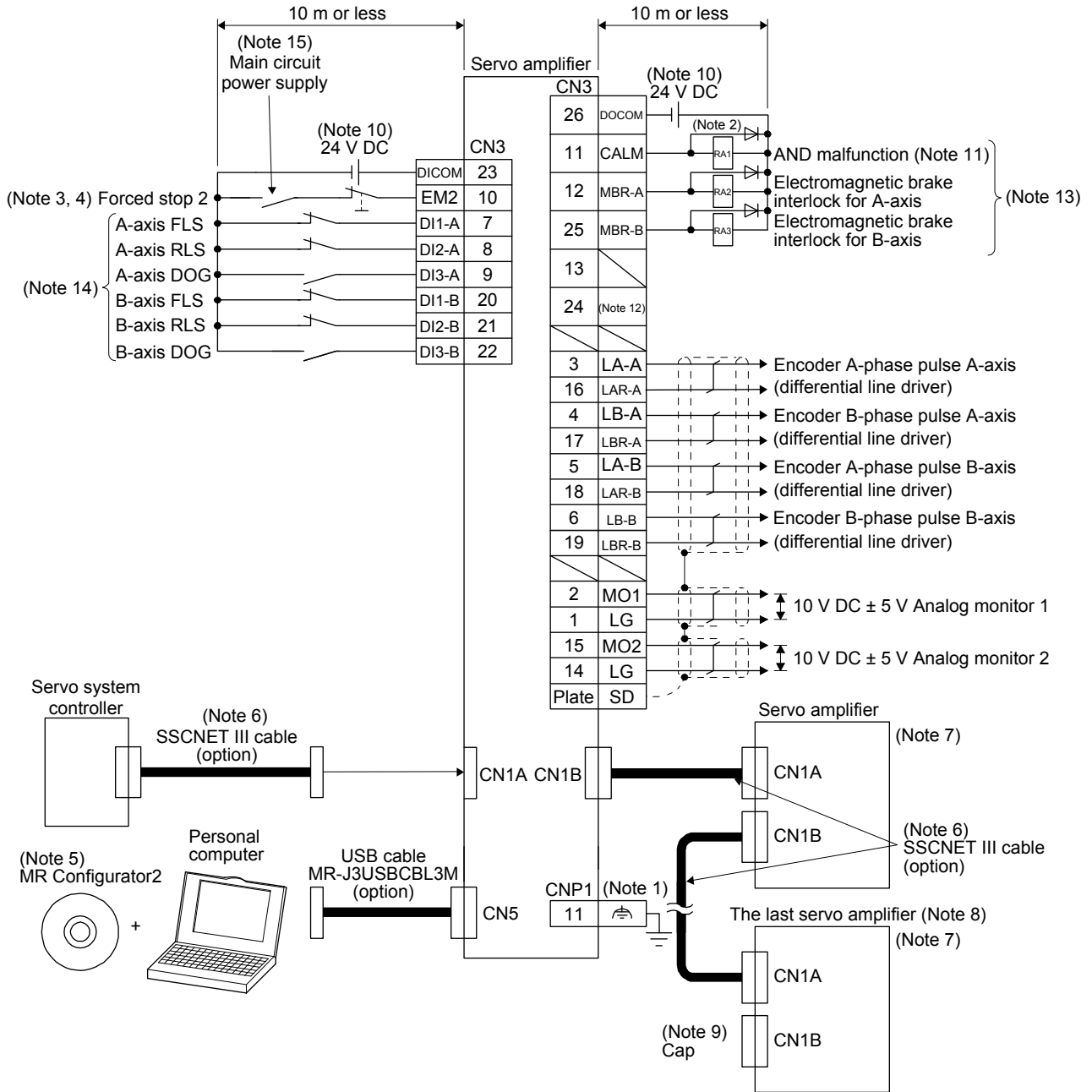

18. MR-J4W2-0303B6 SERVO AMPLIFIER

- Note
1. To prevent an electric shock, always connect the CNP1 noiseless grounding terminal (⚡ marked) of the servo amplifier to the grounding terminal of the cabinet.
 2. Connect the diode in the correct direction. If it is connected reversely, the servo amplifier will malfunction and will not output signals, disabling EM2 (Forced stop 2) and other protective circuits.
 3. If the controller does not have forced stop function, always install the forced stop 2 switch (normally closed contact).
 4. When starting operation, always turn on EM2 (Forced stop 2). (Normally closed contact)
 5. Use SW1DNC-MRC2-_. (Refer to section 11.4.)
 6. Use SSCNET III cables listed in the following table.

| Cable | Cable model | Cable length |
|--------------------------------|--------------|---------------|
| Standard cord inside cabinet | MR-J3BUS_M | 0.15 m to 3 m |
| Standard cable outside cabinet | MR-J3BUS_M-A | 5 m to 20 m |
| Long-distance cable | MR-J3BUS_M-B | 30 m to 50 m |

7. The wiring after the second servo amplifier is omitted.
8. Up to 64 axes of servo amplifiers can be connected. The number of connectable axes depends on the controller you use. Refer to section 18.5 for setting of axis selection.
9. Make sure to cap the unused CN1B connector.
10. Supply 24 V DC \pm 10% to interfaces from outside. The total current capacity is up to 250 mA. 250 mA is the value applicable when all I/O signals are used. The current capacity can be decreased by reducing the number of I/O points. Refer to section 3.8.2 (1) that gives the current value necessary for the interface. The illustration of the 24 V DC power supply is divided between input signal and output signal for convenience. However, they can be configured by one. The 24 V DC power for I/O signal, use power other than 24 V DC power of servo amplifier control circuit power supply.
11. CALM (AND malfunction) turns on in normal alarm-free condition. (Normally closed contact)
12. In the initial setting, CINP (AND in-position) is assigned to the pin. You can change devices of the pin with [Pr. PD08].
13. You can change devices of these pins with [Pr. PD07] and [Pr. PD09].
14. Devices can be assigned for these signals with controller setting. For devices that can be assigned, refer to the controller instruction manual. The following devices can be assigned for R_MTCPU, Q17_DSCPU, RD77MS_, QD77MS_, and LD77MS_.
15. Configure a circuit to turn off EM2 when the main circuit power is turned off to prevent an unexpected restart of the servo amplifier.

18. MR-J4W2-0303B6 SERVO AMPLIFIER

(2) For source I/O interface

| |
|--------------------------------------------|
| POINT |
| ● For notes, refer to (1) in this section. |

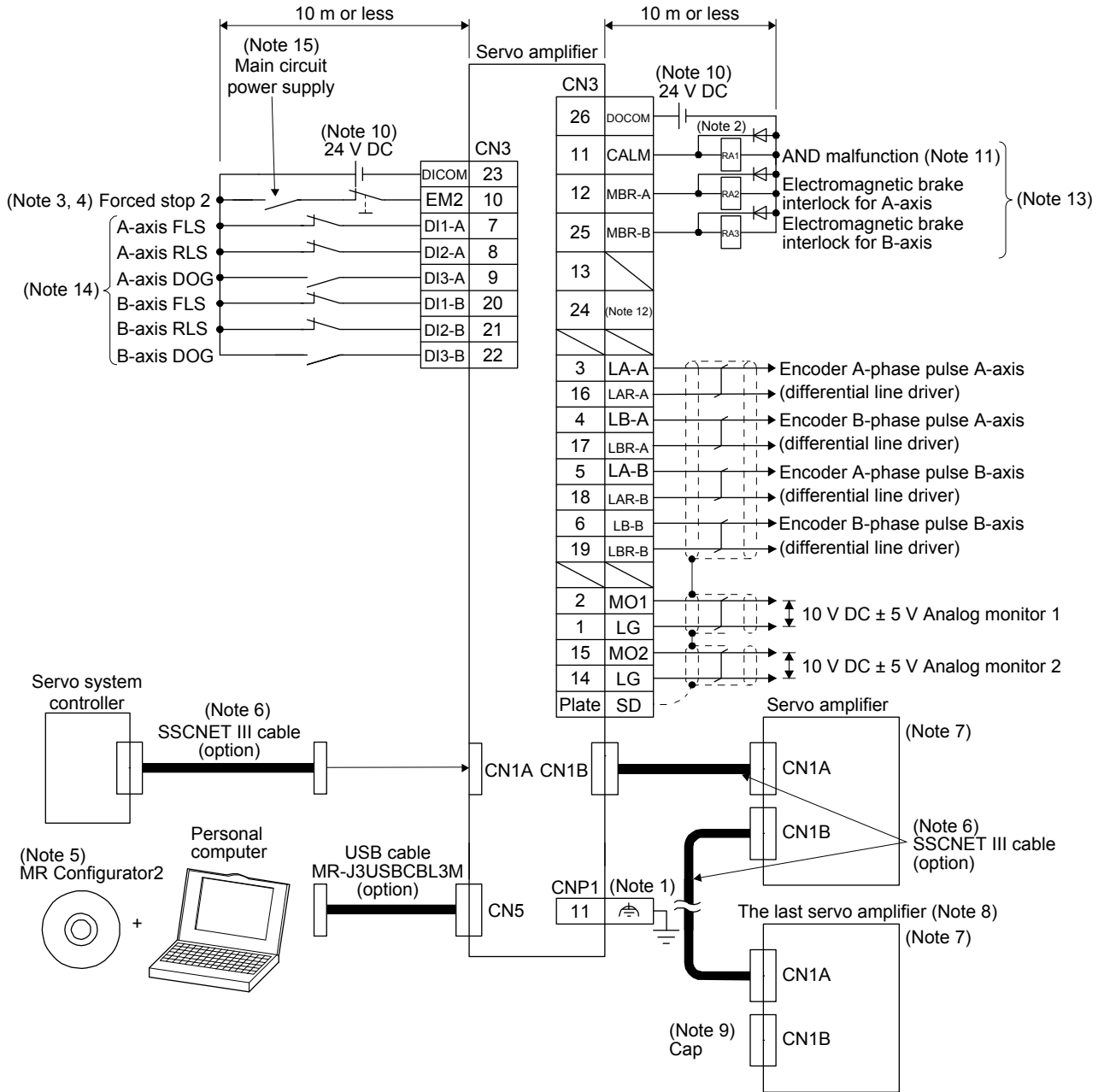

18. MR-J4W2-0303B6 SERVO AMPLIFIER

18.3.6 Connectors and pin assignment

| POINT |
|-------------------------------------------------------------------------------------------------------------------------------------------------------------------------------------------------------------------------------------------------------------------------------------------------------|
| <ul style="list-style-type: none"> ● The pin assignment of the connectors is as viewed from the cable connector wiring section. ● For the CN3 connector, securely connect the external conductor of the shielded cable to the ground plate and fix it to the connector shell. |

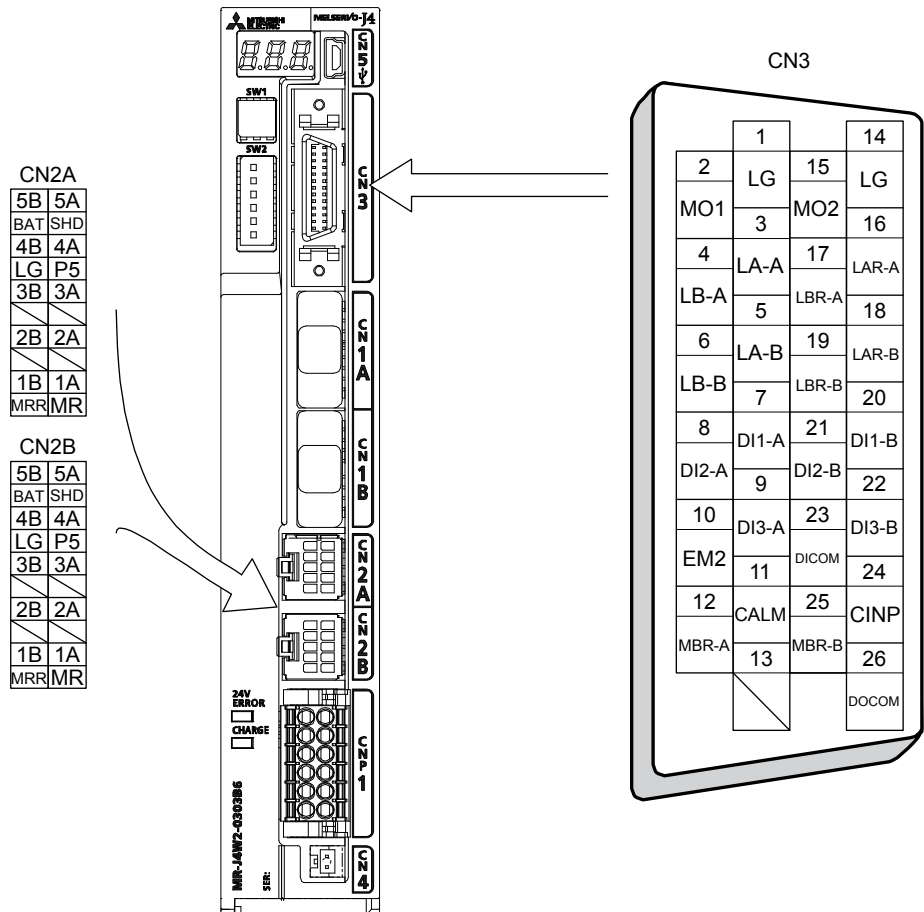

18. MR-J4W2-0303B6 SERVO AMPLIFIER

18.3.7 Signal (device) explanations

For the I/O interfaces (symbols in I/O division column in the table), refer to section 3.8.2 and section 18.3.9 (2).

The pin numbers in the connector pin No. column are those in the initial status.

(1) Input device

| Device | Symbol | Connector pin No. | Function and application | I/O division |
|---------------|--------|-------------------|------------------------------------------------|--------------|
| Forced stop 2 | EM2 | CN3-10 | For details of device, refer to section 3.5.1. | DI-1 |
| Forced stop 1 | EM1 | (CN3-10) | | DI-1 |
| / | DI1-A | CN3-7 | | DI-1 |
| | DI2-A | CN3-8 | | DI-1 |
| | DI3-A | CN3-9 | | DI-1 |
| | DI1-B | CN3-20 | | DI-1 |
| | DI2-B | CN3-21 | | DI-1 |
| | DI3-B | CN3-22 | | DI-1 |

(2) Output device

(a) Output device pin

The following shows the output device pins and parameters for assigning devices.

| Connector pin No. | Parameter | | Initial device | I/O division | Remark |
|-------------------|------------|------------|----------------|--------------|------------|
| | A-axis | B-axis | | | |
| CN3-12 | [Pr. PD07] | / | MBR-A | DO-1 | For A-axis |
| CN3-25 | / | [Pr. PD07] | MBR-B | | For B-axis |
| CN3-11 | [Pr. PD09] | [Pr. PD09] | CALM | | Common pin |
| CN3-24 | [Pr. PD08] | [Pr. PD08] | CINP | | Common pin |

(b) Output device explanations

| | | |
|--------------------------------------------------|-----------------------------------------------------------------------------------------------------------------------|-------------------------------------------------------------------------------------|
| POINT | <p>● Initial letter and last letter with hyphen in device symbols mean target axis. Refer to the following table.</p> | |
| Symbol (Note) | Target axis | Description |
| C _ _ _ | A axis/B axis | When both axes of A and B meet a condition, the device will be enabled (on or off). |
| X _ _ _ | A axis/B axis | When each axis of A or B meets a condition, the device will be enabled (on or off). |
| _ _ _ -A | A axis | Device for A axis |
| _ _ _ -B | B axis | Device for B axis |
| <p>Note. _ _ _ differs depending on devices.</p> | | |

18. MR-J4W2-0303B6 SERVO AMPLIFIER

| Device | Symbol | Function and application |
|--------------------------------------------|--------|------------------------------------------------|
| AND electromagnetic brake interlock | CMBR | For details of device, refer to section 3.5.2. |
| OR electromagnetic brake interlock | XMBR | |
| Electromagnetic brake interlock for A-axis | MBR-A | |
| Electromagnetic brake interlock for B-axis | MBR-B | |
| AND malfunction | CALM | |
| OR malfunction | XALM | |
| Malfunction for A-axis | ALM-A | |
| Malfunction for B-axis | ALM-B | |
| AND in-position | CINP | |
| OR in-position | XINP | |
| In-position for A-axis | INP-A | |
| In-position for B-axis | INP-B | |
| AND ready | CRD | |
| OR ready | XRD | |
| Common ready for A-axis | RD-A | |
| Common ready for B-axis | RD-B | |
| AND speed reached | CSA | |
| OR speed reached | XSA | |
| Speed reached for A-axis | SA-A | |
| Speed reached for B-axis | SA-B | |
| AND limiting speed | CVLC | |
| OR limiting speed | XVLC | |
| Limiting speed for A-axis | VLC-A | |
| Limiting speed for B-axis | VLC-B | |
| AND zero speed detection | CZSP | |
| OR zero speed detection | XZSP | |
| Zero speed detection for A-axis | ZSP-A | |
| Zero speed detection for B-axis | ZSP-B | |
| AND limiting torque | CTLC | |
| OR limiting torque | XTLC | |
| Limiting torque for A-axis | TLC-A | |
| Limiting torque for B-axis | TLC-B | |
| AND warning | CWNG | |
| OR warning | XWNG | |
| Warning for A-axis | WNG-A | |
| Warning for B-axis | WNG-B | |
| AND battery warning | CBWNG | |
| OR battery warning | XBWNG | |
| Battery warning for A-axis | BWNG-A | |
| Battery warning for B-axis | BWNG-B | |

18. MR-J4W2-0303B6 SERVO AMPLIFIER

| Device | Symbol | Function and application |
|-------------------------------------------|--------|------------------------------------------------|
| AND variable gain selection | CCDPS | For details of device, refer to section 3.5.2. |
| OR variable gain selection | XCDPS | |
| Variable gain selection for A-axis | CDPS-A | |
| Variable gain selection for B-axis | CDPS-B | |
| AND absolute position undetermined | CABSV | |
| OR absolute position undetermined | XABSV | |
| Absolute position undetermined for A-axis | ABSV-A | |
| Absolute position undetermined for B-axis | ABSV-B | |

(3) Output signal

| Signal name | Symbol | Connector Pin No. | Function and application |
|-------------------------------------------------------|---------------|-------------------|-----------------------------------------------|
| Encoder A-phase pulse A (differential line driver) | LA-A LAR-A | CN3-3 CN3-16 | Refer to section 3.5.3 for details of signal. |
| Encoder B-phase pulse A (differential line driver) | LB-A LBR-A | CN3-4 CN3-17 | |
| Encoder A-phase pulse B (differential line driver) | LA-B LAR-B | CN3-5 CN3-18 | |
| Encoder B-phase pulse B (differential line driver) | LB-B LBR-B | CN3-6 CN3-19 | |

(4) Power supply

| Signal name | Symbol | Connector Pin No. | Function and application |
|-----------------------------------|--------|-------------------|-------------------------------------------------------------------------------------------------------------------------------------------------------------------------------------------------------------------------------------------------------------------------------------------------------|
| Digital I/F Power supply input | DICOM | CN3-23 | Input 24 V DC (24 V DC \pm 10% 250 mA) for I/O interface. The power supply capacity changes depending on the number of I/O interface points to be used. For sink interface, connect + of 24 V DC external power supply. For source interface, connect - of the 24 V DC external power supply. |
| Digital I/F Common | DOCOM | CN3-26 | Common terminal of input signal such as EM2 of the servo amplifier. This is separated from LG. For sink interface, connect - of 24 V DC external power supply. For source interface, connect + of the 24 V DC external power supply. |
| Control common | LG | CN3-1 CN3-14 | This is for encoder output pulses (differential line driver). |
| Shield | SD | Plate | Connect the external conductor of the shielded wire. |

18. MR-J4W2-0303B6 SERVO AMPLIFIER

(5) Analog monitor output

| Signal name | Symbol | Connector pin No. | Function and application | I/O division |
|------------------|--------|-------------------|-----------------------------------------------------------------------------------------------------------------------------------------------------------------|---------------|
| Analog monitor 1 | MO1 | CN3-2 | This is used to output the data set in [Pr. PC09] to between MO1 and LG in terms of voltage. Output voltage: 10 V ± 5 V Resolution: 10 bits or equivalent | Analog output |
| Analog monitor 2 | MO2 | CN3-15 | This signal outputs the data set in [Pr. PC10] to between MO2 and LG in terms of voltage. Output voltage: 10 V ± 5 V Resolution: 10 bits or equivalent | Analog output |

(6) Analog monitor

| POINT |
|--------------------------------------------------------------------|
| ● A voltage of analog monitor output may be irregular at power-on. |

The servo status can be outputted to two channels in terms of voltage.

(a) Setting

Change the following digits of [Pr. PC09] and [Pr. PC10].

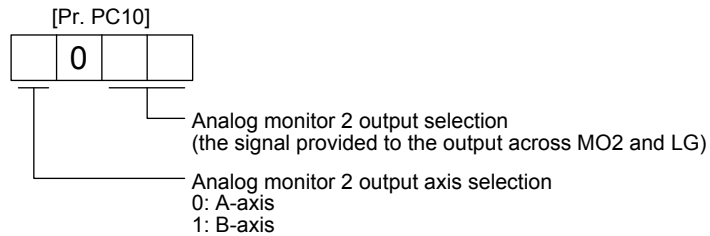
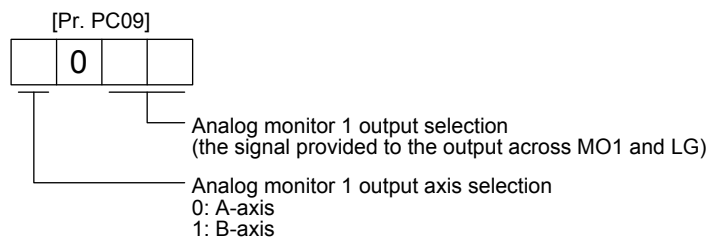

[Pr. PC11] and [Pr. PC12] can be used to set the offset voltages to the analog output voltages.
Setting value is -9999 mV to 9999 mV.

| Parameter | Description | Setting range [mV] |
|-----------|---------------------------------------------------|--------------------|
| PC11 | Set the offset voltage of MO1 (Analog monitor 1). | -9999 to 9999 |
| PC12 | Set the offset voltage of MO2 (Analog monitor 2). | |

18. MR-J4W2-0303B6 SERVO AMPLIFIER

(b) Set content

The servo amplifier is factory-set to output the servo motor speed to MO1 (Analog monitor 1) and the torque to MO2 (Analog monitor 2). The setting can be changed by setting in [Pr. PC09] and [Pr. PC10] as follows. Refer to (6) (c) in this section for detection point.

| Setting value | Output item | Description | Setting value | Output item | Description |
|---------------|------------------------------------------------------------------------------------------------------|-------------|---------------|-------------------------------------------------------------------------------------------------------|-------------|
| 00 | Servo motor speed ($10\text{ V} \pm 4\text{ V}/\text{max. speed}$) | | 01 | Torque (Note 4) ($10\text{ V} \pm 4\text{ V}/\text{max. torque}$) | |
| 02 | Servo motor speed ($10\text{ V} \pm 4\text{ V}/\text{max. speed}$) | | 03 | Torque (Note 4) ($10\text{ V} \pm 4\text{ V}/\text{max. torque}$) | |
| 04 | Current command (Note 4) ($10\text{ V} \pm 4\text{ V}/\text{max. current command}$) | | 05 | Speed command (Note 2) ($10\text{ V} \pm 4\text{ V}/\text{max. speed}$) | |
| 06 | Servo motor-side droop pulses (Note 1, 2, 3) ($10\text{ V} \pm 5\text{ V}/100\text{ pulses}$) | | 07 | Servo motor-side droop pulses (Note 1, 2, 3) ($10\text{ V} \pm 5\text{ V}/1000\text{ pulses}$) | |
| 08 | Servo motor-side droop pulses (Note 1, 2, 3) ($10\text{ V} \pm 5\text{ V}/10000\text{ pulses}$) | | 09 | Servo motor-side droop pulses (Note 1, 2, 3) ($10\text{ V} \pm 5\text{ V}/100000\text{ pulses}$) | |
| 0A | Feedback position ($10\text{ V} \pm 5\text{ V}/1\text{ Mpulse}$) | | 0B | Feedback position ($10\text{ V} \pm 5\text{ V}/10\text{ Mpulses}$) | |

18. MR-J4W2-0303B6 SERVO AMPLIFIER

| Setting value | Output item | Description | Setting value | Output item | Description |
|---------------|---------------------------------------------------------|-------------|---------------|---------------------------------------------------------|-------------|
| 0C | Feedback position (10 V ± 5 V/100 Mpulses) | | 0D | Bus voltage (10 V + 5 V/100 V) | |
| 0E | Speed command 2 (Note 2) (10 V ± 4 V/ max. speed) | | 17 | Internal temperature of encoder (10 V ± 5 V/±128 °C) | |

- Note
1. Encoder pulse unit
 2. This cannot be used in the torque control mode.
 3. This cannot be used in the speed control mode.
 4. For details on the value of the maximum current command (maximum torque) for 10 V ± 4 V, refer to (d) in this section.

18. MR-J4W2-0303B6 SERVO AMPLIFIER

(c) Analog monitor block diagram

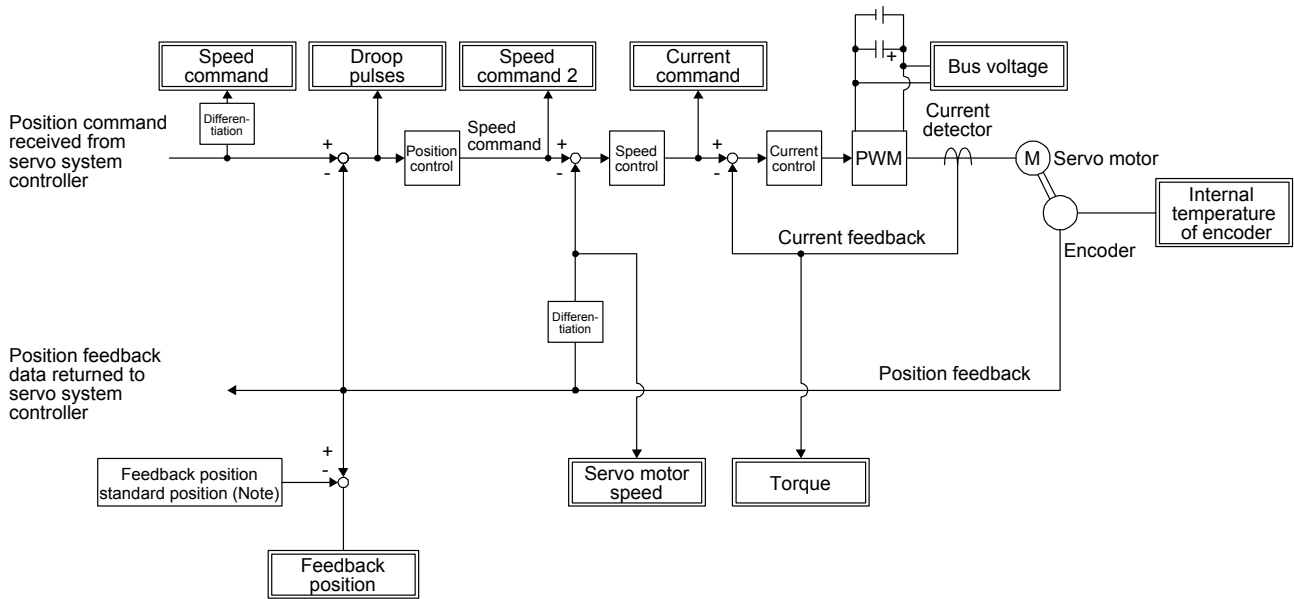

Note. The feedback position is outputted based on the position data passed between servo system controller and servo amplifier. [Pr. PC13] and [Pr. PC14] can set up the standard position of feedback position that is outputted to analog monitor in order to adjust the output range of feedback position. The setting range is between -9999 pulses and 9999 pulses.

$$\text{Standard position of feedback position} = [\text{Pr. PC14}] \text{ setting value} \times 10000 + [\text{Pr. PC13}] \text{ setting value}$$

| Parameter | Description | Setting range |
|-----------|-------------------------------------------------------------------------------|------------------------------|
| PC13 | Set the lower-order four digits of the standard position of feedback position | -9999 to 9999 [pulse] |
| PC14 | Set the upper-order four digits of the standard position of feedback position | -9999 to 9999 [10000 pulses] |

(d) Maximum current command (maximum torque) for analog monitor 10 V ±4 V

Values of the maximum current command (maximum torque) when the analog monitor is 10 V ±4 V are listed.

The current command (torque) outputs the maximum current command (maximum torque) at 10 V ±4 V. The maximum current command (maximum torque) may not match the rated current/maximum current ratio since it is created from the torque current in the servo amplifier.

| Servo motor | | Servo amplifier/drive unit | Maximum current command (maximum torque) [%] |
|--------------|-----------|----------------------------|----------------------------------------------|
| HG-AK series | HG-AK0136 | MR-J4W2-0303B6 | 380 |
| | HG-AK0236 | MR-J4W2-0303B6 | 380 |
| | HG-AK0336 | MR-J4W2-0303B6 | 363 |

18. MR-J4W2-0303B6 SERVO AMPLIFIER

18.3.8 Alarm occurrence timing chart



CAUTION

- When an alarm has occurred, remove its cause, make sure that the operation signal is not being input, ensure safety, and reset the alarm before restarting operation.
- When alarms are occurring in both axes of A and B, shut off the main circuit power supply. Not doing so may cause a fire when a regenerative transistor malfunctions or the like may overheat the built-in regenerative resistor.

| |
|---------------------------------------------------------------------------------------|
| POINT |
| ● In the torque control mode, the forced stop deceleration function is not available. |

To deactivate the alarm, cycle the control circuit power or give the error reset or CPU reset command from the servo system controller. However, the alarm cannot be deactivated unless its cause is removed.

(1) When you use the forced stop deceleration function

| |
|------------------------------------------------------------------------|
| POINT |
| ● To enable the function, set "2 _ _ _ (initial value)" in [Pr. PA04]. |

(a) When the forced stop deceleration function is enabled

When an all-axis stop alarm occurs, all axes will be the operation status below. When a corresponding axis stop alarm occurs, only the axis will be the operation status below. You can normally operate the axis that any alarm is not occurring.

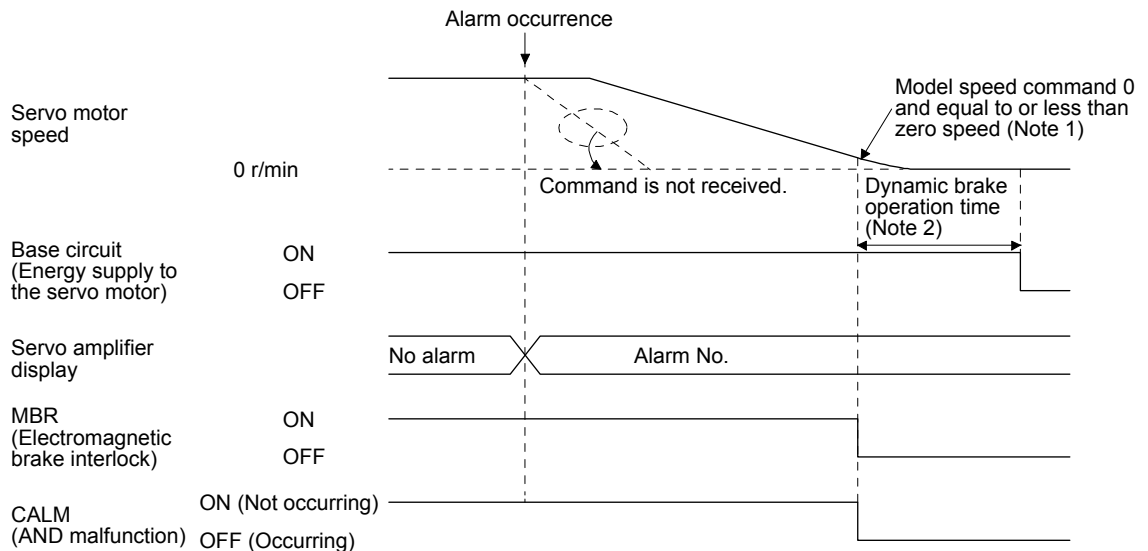

- Note 1. The model speed command is a speed command generated in the servo amplifier for forced stop deceleration of the servo motor.
- Note 2. If the servo motor speed is 5 r/min or higher at this point, the electric dynamic brake will operate continuously for the time period set by [Pr. PF12].

18. MR-J4W2-0303B6 SERVO AMPLIFIER

(b) When the forced stop deceleration function is not enabled

When an all-axis stop alarm occurs, all axes will be the operation status below. When a corresponding axis stop alarm occurs, only the axis will be the operation status below. You can normally operate the axis that any alarm is not occurring.

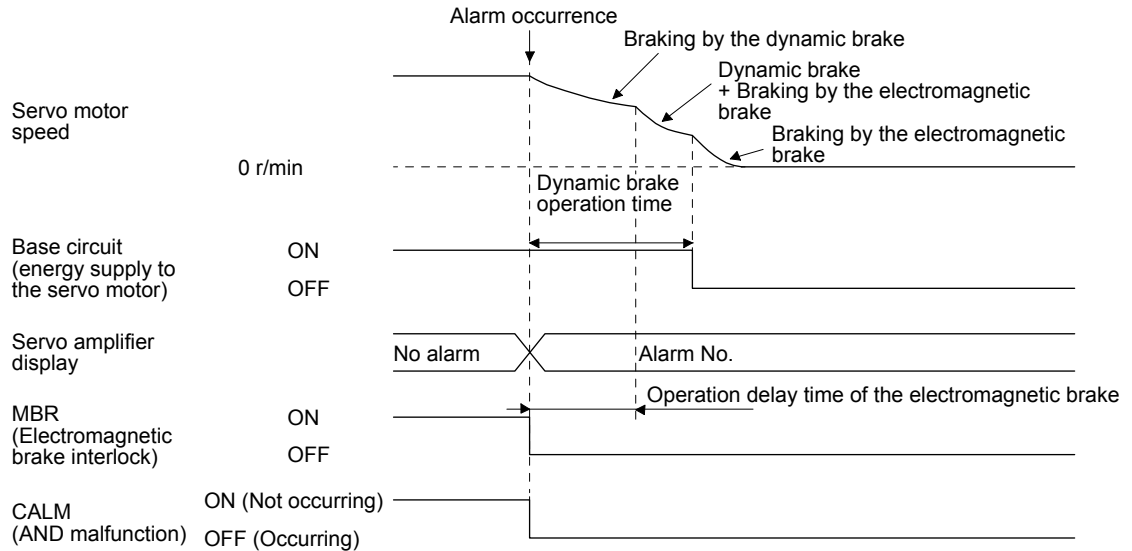

(c) When SSCNET III/H communication is shut-off

When SSCNET III/H communication is shut-off, all axes will be the operation status below. The display of servo amplifier differs by the shut off status of communication (d1 or E7).

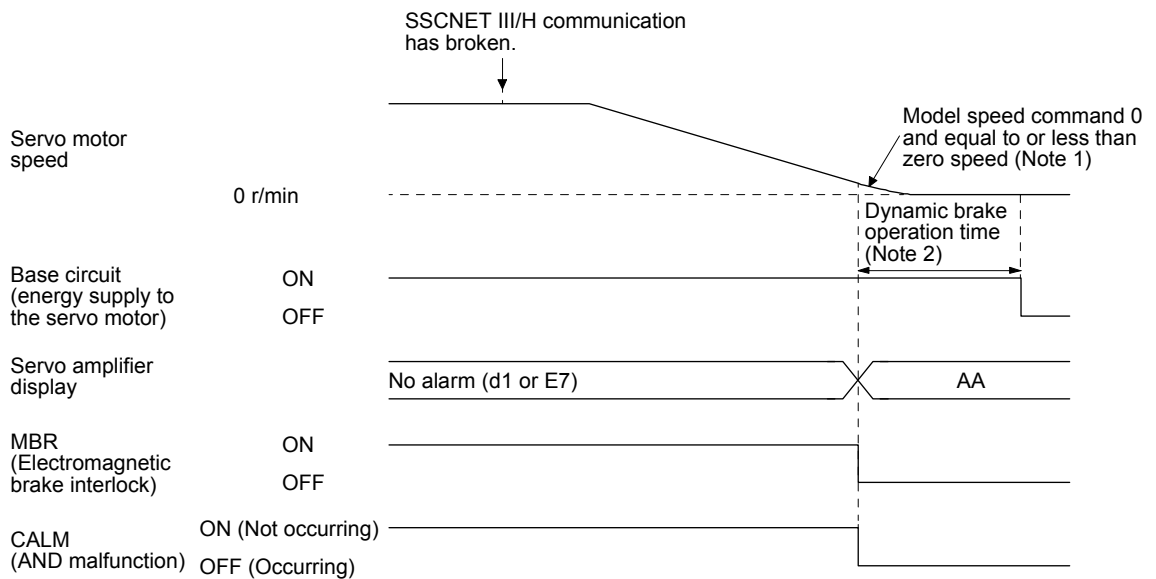

- Note 1. The model speed command is a speed command generated in the servo amplifier for forced stop deceleration of the servo motor.
- Note 2. If the servo motor speed is 5 r/min or higher at this point, the electric dynamic brake will operate continuously for the time period set by [Pr. PF12].

18. MR-J4W2-0303B6 SERVO AMPLIFIER

(2) When you do not use the forced stop deceleration function

| |
|--------------------------------------------------------|
| POINT |
| ●To disable the function, set "0 _ _ _" in [Pr. PA04]. |

The timing chart that shows the servo motor condition when an alarm or SSCNETIII/H communication shut-off occurs is the same as (1) (b) in this section.

18.3.9 Interfaces

The items in the following table are the same as those for MR-J4W2-_B and MR-J4W3-_B servo amplifiers. Refer to the section of the detailed explanation field for details.

| Item | Detailed explanation |
|--------------------------------------------------------------|----------------------|
| Detailed description of interfaces (excluding analog output) | Section 3.8.2 |
| Source I/O interface | Section 3.8.3 |

18. MR-J4W2-0303B6 SERVO AMPLIFIER

(1) Internal connection diagram

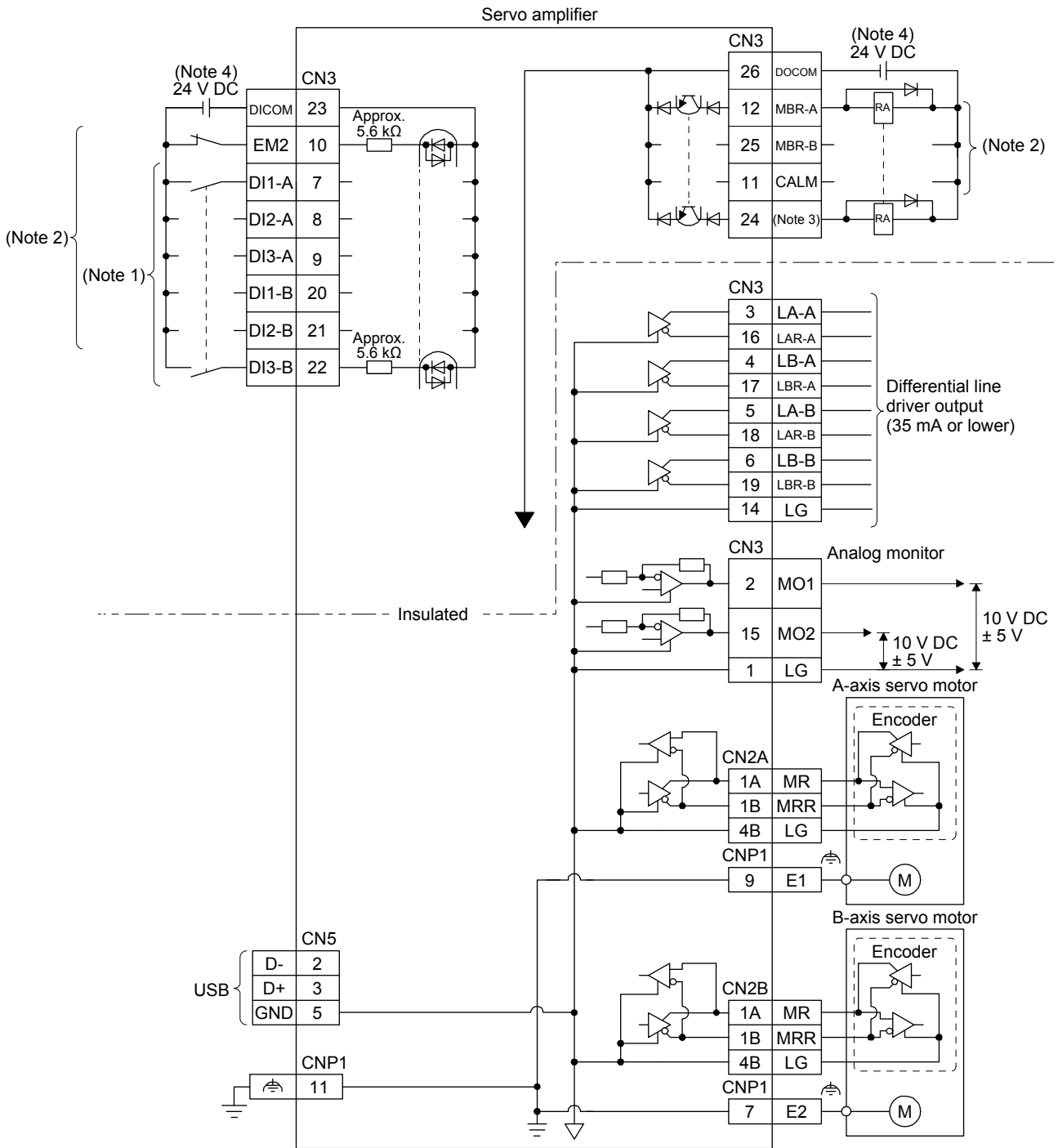

- Note 1. Signal can be assigned for these pins with the controller setting.
 For contents of signals, refer to the instruction manual of the controller.
- Note 2. This diagram shows sink I/O interface. For source I/O interface, refer to section 3.8.3.
- Note 3. In the initial setting, CINP (AND in-position) is assigned to the pin. You can change devices of the pin with [Pr. PD08].
- Note 4. The illustration of the 24 V DC power supply is divided between input signal and output signal for convenience. However, they can be configured by one.
 The 24 V DC power for I/O signal, use power other than 24 V DC power of servo amplifier control circuit power supply.

18. MR-J4W2-0303B6 SERVO AMPLIFIER

(2) Detailed description of interfaces (analog output)

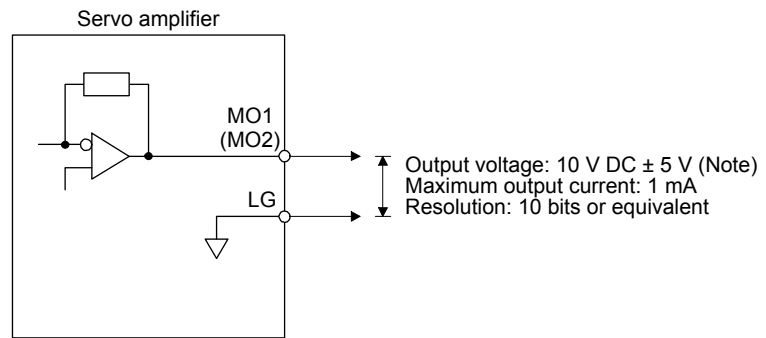

Note. Output voltage range varies depending on the output contents.

18. MR-J4W2-0303B6 SERVO AMPLIFIER

18.3.10 Grounding

⚠ WARNING ● Ground the servo amplifier and servo motor securely.
 ● To prevent an electric shock, always connect the noiseless grounding terminal (marked ⏏) of the servo amplifier to the grounding terminal of the cabinet.

The servo amplifier switches the power transistor on-off to supply power to the servo motor. Depending on the wiring and ground cable routing, the servo amplifier may be affected by the switching noise (due to di/dt and dv/dt) of the transistor. To prevent such a fault, refer to the following diagram and always ground. To conform to the EMC Directive, refer to "EMC Installation Guidelines".

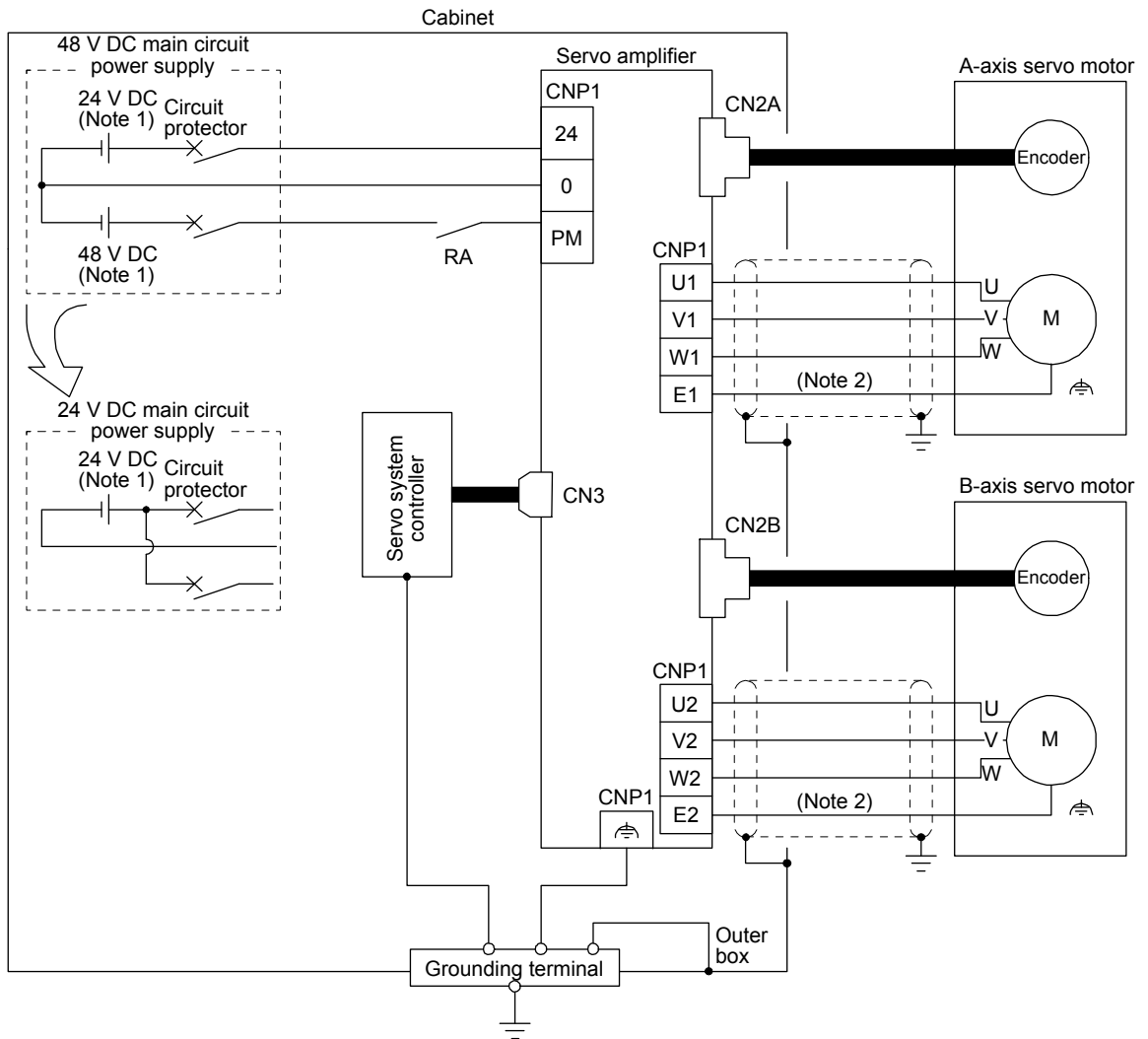



Note 1. For power supply specifications, refer to section 18.1.3.

Note 2. Connect ⏏ of servo motor to E1 and E2 of the CNP1 connector. Do not connect the wire directly to the grounding terminal of the cabinet.

18. MR-J4W2-0303B6 SERVO AMPLIFIER

18.4 Startup

| |
|-------------------------------------------------------------------------------------------------------------------------------------------------------------------------------------------|
|  WARNING ● Do not operate the switches with wet hands. Otherwise, it may cause an electric shock. |
|-------------------------------------------------------------------------------------------------------------------------------------------------------------------------------------------|

| | |
|--------------------------------------------------------------------------------------------------|--------------------------------------------------------------------------------------------------------------------------------------------------------------------------------------------------------------------------------------------------------------------------------------------------------------------------------------------------------------------------------------------------------------------------------------------------------------------------------------------------------------------|
|  CAUTION | <ul style="list-style-type: none">● Before starting operation, check the parameters. Improper settings may cause some machines to operate unexpectedly.● The servo amplifier and servo motor may be hot while the power is on and for some time after power-off. Take safety measures such as providing covers to avoid accidentally touching them by hands and parts such as cables.● During operation, never touch the rotor of the servo motor. Otherwise, it may cause injury. |
|--------------------------------------------------------------------------------------------------|--------------------------------------------------------------------------------------------------------------------------------------------------------------------------------------------------------------------------------------------------------------------------------------------------------------------------------------------------------------------------------------------------------------------------------------------------------------------------------------------------------------------|

The items in the following table are the same as those for MR-J4W2-_B and MR-J4W3-_B servo amplifiers. Refer to the section of the detailed explanation field for details.

| Item | Detailed explanation |
|----------------------------------------------------------------------|----------------------|
| Startup | Section 4.2 |
| Switch setting and display of the servo amplifier (excluding a part) | Section 4.3 |
| Test operation | Section 4.4 |
| Test operation mode | Section 4.5 |

18. MR-J4W2-0303B6 SERVO AMPLIFIER

18.4.1 Startup procedure

When switching power on for the first time, follow this section to make a startup.

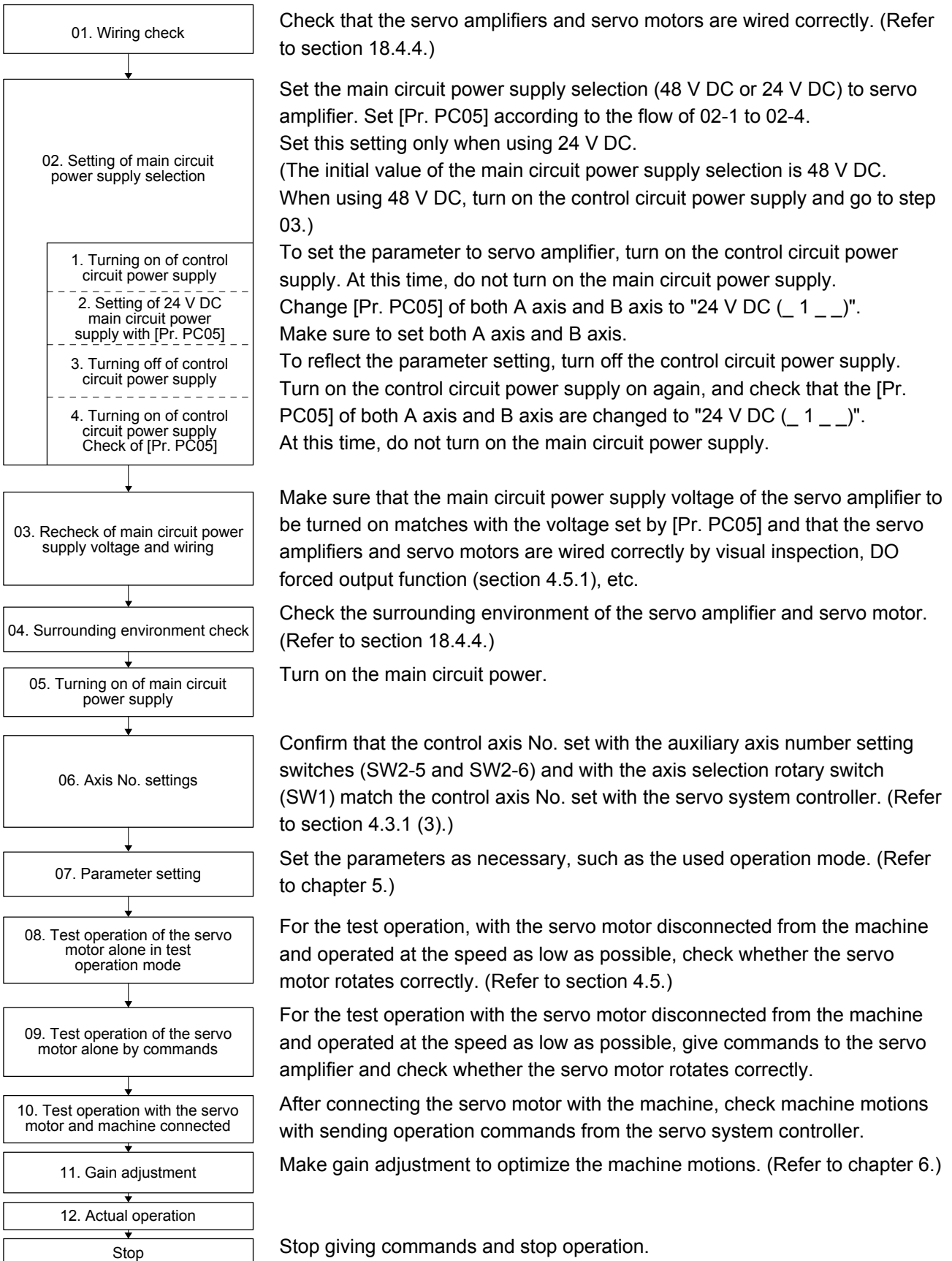

18. MR-J4W2-0303B6 SERVO AMPLIFIER

18.4.2 Troubleshooting when "24V ERROR" lamp turns on

- (1) When overvoltage is applied to the control circuit in the servo amplifier, power supply to the circuit will be shut off and the "24V ERROR" lamp will turn on. Then, the 3-digit, 7-segment LED on display will turn off. Immediately turn off the power and check the wiring, etc. to the main circuit power supply (48 V DC).
- (2) If the "24V ERROR" lamp turns on with the 3-digit, 7-segment LED on, the control circuit power supply voltage (24 V DC) may be failure. Check that the voltage of the control circuit power supply is 21.6 V DC or more.

18.4.3 Wiring check

(1) Power supply system wiring

Before switching on the main circuit and control circuit power supplies, check the following items.

(a) Power supply system wiring

The power supplied to the power input terminals (24/0/PM) of the servo amplifier should satisfy the defined specifications. (Refer to section 18.1.3)

(b) Connection of servo amplifier and servo motor

- 1) Check that each A axis servo motor and B axis servo motor is connected to CNP1 connector of servo amplifier. Additionally, the servo amplifier power output (U/V/W) should match in phase with the servo motor power input terminals (U/V/W).

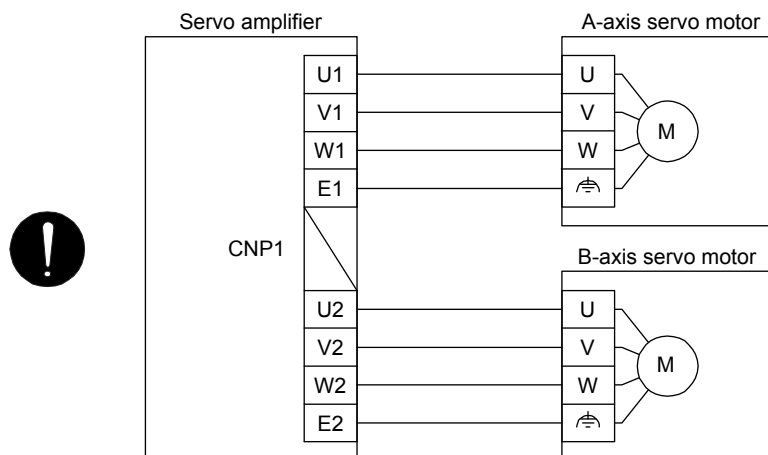

- 2) The power supplied to the servo amplifier should not be connected to the servo motor power terminals (U/V/W). Doing so will fail the servo amplifier and servo motor.

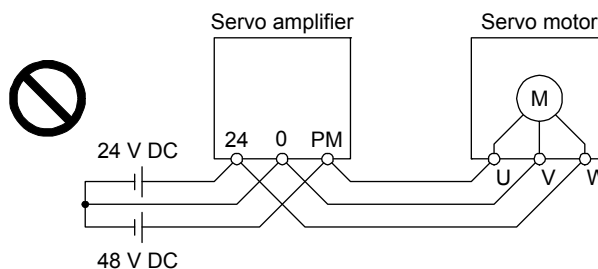

18. MR-J4W2-0303B6 SERVO AMPLIFIER

- 3) The noiseless grounding terminal of the servo motor should be connected to the E1 terminal and E2 terminal of the servo amplifier.

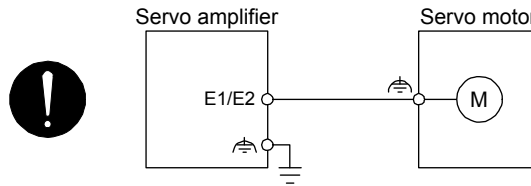

- 4) The encoder of the A axis and B axis servo motors should be connected respectively to the CN2A and CN2B connectors of the servo amplifier.

(2) I/O signal wiring

- (a) The I/O signals should be connected correctly.

Use DO forced output to forcibly turn on/off the pins of the CN3 connector. You can use the function to check the wiring. In this case, switch on the control circuit power supply only.

For details of I/O signal connection, refer to section 18.3.5.

- (b) A voltage exceeding 24 V DC is not applied to the pins of the CN3 connector.

- (c) Between plate and DOCOM of the CN3 connector should not be shorted.

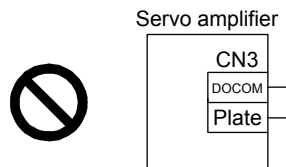

18.4.4 Surrounding environment

(1) Cable routing

- (a) The wiring cables should not be stressed.
- (b) The encoder cable should not be used in excess of its bending life. (Refer to section 10.4)
- (c) The connector of the servo motor should not be stressed.

(2) Environment

Signal cables and power cables are not shorted by wire offcuts, metallic dust or the like.







18. MR-J4W2-0303B6 SERVO AMPLIFIER

18.5 Switch setting and display of the servo amplifier

Switching to the test operation mode, deactivating control axes, and setting control axis No. are enabled with switches on the servo amplifier.

On the servo amplifier display (three-digit, seven-segment LED), check the status of communication with the servo system controller at power-on, and the axis number, and diagnose a malfunction at occurrence of an alarm.

The control axis setting switches of MR-J4W2-0303B6 servo amplifier are aligned vertically unlike other MR-J4 2-axis servo amplifiers; however, the use of each number switch is the same.

| | Application |
|-----------------------------------------------------------------------------------|--------------------------------------------|
|  | 1 Test operation select switch |
|  | 2 Disabling control axis switch for A-axis |
|  | 3 Disabling control axis switch for B-axis |
|  | 4 For manufacturer setting |
|  | 5 Auxiliary axis number setting switch |
|  | 6 Auxiliary axis number setting switch |

The items in the following table are the same as those for MR-J4W2-_B and MR-J4W3-_B servo amplifiers. Refer to the section of the detailed explanation field for details.

| Item | Detailed explanation |
|---------------------------|----------------------|
| Switches | Section 4.3.1 |
| Scrolling display | Section 4.3.2 |
| Status display of an axis | Section 4.3.3 |

18. MR-J4W2-0303B6 SERVO AMPLIFIER

18.6 Dimensions

[Unit: mm]

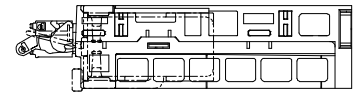
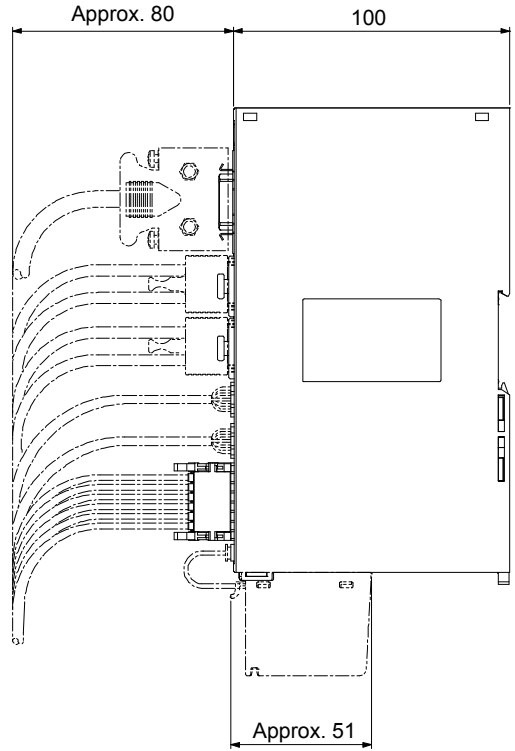
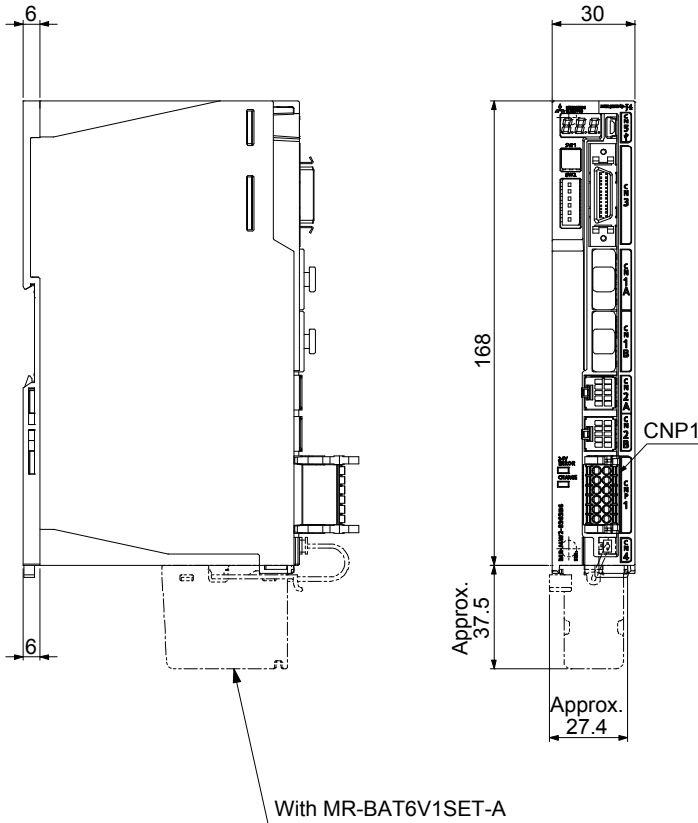

Mass: 0.3 [kg]

Mounting screw
Screw size: M5
Tightening torque: 1.87
[N·m]

| Terminal | |
|----------|----------|
| CNP1 | |
| 6 | 24 0 12 |
| 5 | PM 11 |
| 4 | U1 W1 10 |
| 3 | V1 E1 9 |
| 2 | U2 W2 8 |
| 1 | V2 E2 7 |

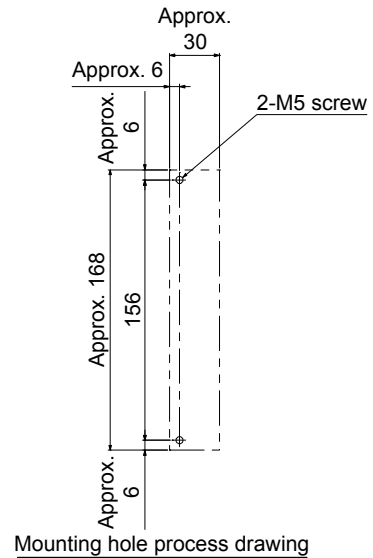

18. MR-J4W2-0303B6 SERVO AMPLIFIER

18.7 Characteristics

The items in the following table are the same as those for MR-J4W2-_B and MR-J4W3-_B servo amplifiers. Refer to the section of the detailed explanation field for details.

| Item | Detailed explanation |
|--------------------|----------------------|
| Cable bending life | Section 10.4 |

18.7.1 Overload protection characteristics

An electronic thermal is built in the servo amplifier to protect the servo motor, servo amplifier and servo motor power wires from overloads.

[AL. 50 Overload 1] occurs if overload operation performed is above the electronic thermal protection curve shown in fig. 18.1. [AL. 51 Overload 2] occurs if the maximum current is applied continuously for several seconds due to machine collision, etc. Use the equipment on the left-side area of the continuous or broken line in the graph.

For the system where the unbalanced torque occurs, such as a vertical axis system, the unbalanced torque of the machine should be kept at 70% or less of the rated torque.

This servo amplifier has a servo motor overload protection for each axis. (The servo motor overload current (full load current) is set on the basis of 120% rated current of the servo amplifier.)

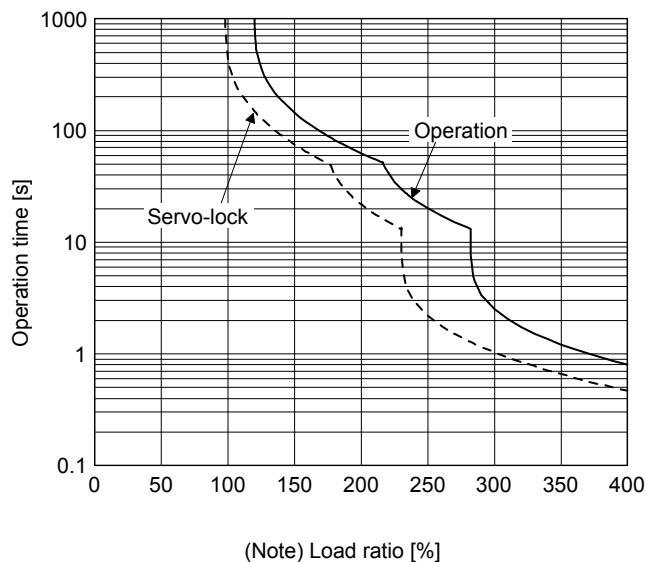

HG-AK0136/HG-AK0236/HG-AK0336

Note. If operation that generates torque more than 100% of the rating is performed with an abnormally high frequency in a servo motor stop status (servo-lock status) or in a 50 r/min or less low-speed operation status, the servo amplifier may malfunction regardless of the electronic thermal protection.

Fig. 18.1 Electronic thermal protection characteristics

18. MR-J4W2-0303B6 SERVO AMPLIFIER

18.7.2 Power supply capacity and generated loss

Table 18.3 indicates the required power supply capacities for main circuit and losses generated under rated load of the servo amplifier. For thermal design of an enclosed type cabinet, use the values in the table in consideration for the worst operating conditions. The actual amount of generated heat will be intermediate between values at rated torque and servo-off according to the duty used during operation. When operating the servo motor under the rated speed, required power supply capacities for main circuit will be less than the value of the table.

The values in the table show when the same servo motors are used for both A axis and B axis. When using different servo motors, estimate the values with an average of the two motors.

Table 18.3 Power supply capacity and generated heat per servo amplifier at rated output

| Servo motor (×2) | Main circuit (48 V DC/24 V DC) Required power supply capacity [W] | (Note) Servo amplifier-generated heat [W] | |
|---------------------|----------------------------------------------------------------------|-------------------------------------------|----------------|
| | | At rated output | With servo-off |
| HG-AK0136 | 460 | 13 | 3 |
| HG-AK0236 | 720 | 19 | 3 |
| HG-AK0336 | 960 | 27 | 3 |

Note. Heat generated during regeneration is not included in the servo amplifier-generated heat.

18.7.3 Dynamic brake characteristics

| POINT |
|---------------------------------------------------------------------------------------------------------------------------------------------------------------------------------------------------------------------------------------------------------------------------------------------------------------------------------------------------------------------------------------------------------------------------------------------------------------------------------------------------------------------------------------------------------------------------------------------------------------------------------------------------------------|
| <ul style="list-style-type: none"> ● The dynamic brake of MR-J4W2-0303B6 is an electronic type. ● Do not use dynamic brake to stop in a normal operation as it is the function to stop in emergency. ● Be sure to enable EM1 (Forced stop 1) after servo motor stops when using EM1 (Forced stop 1) frequently in other than emergency. ● The time constant "τ" for the electronic dynamic brake will be shorter than that of normal dynamic brake. Therefore, coasting distance will be longer than that of normal dynamic brake. For how to set the electronic dynamic brake, refer to [Pr. PF06] and [Pr. PF12]. |

18. MR-J4W2-0303B6 SERVO AMPLIFIER

(1) Dynamic brake operation

(a) Calculation of coasting distance

Fig. 18.2 shows the pattern in which the servo motor comes to a stop when the dynamic brake is operated. Use equation (18.1) to calculate an approximate coasting distance to a stop. The dynamic brake time constant τ varies with the servo motor and machine operation speeds. (Refer to (1) (b) in this section.)

A working part generally has a friction force. Therefore, actual coasting distance will be shorter than a maximum coasting distance calculated with the following equation.

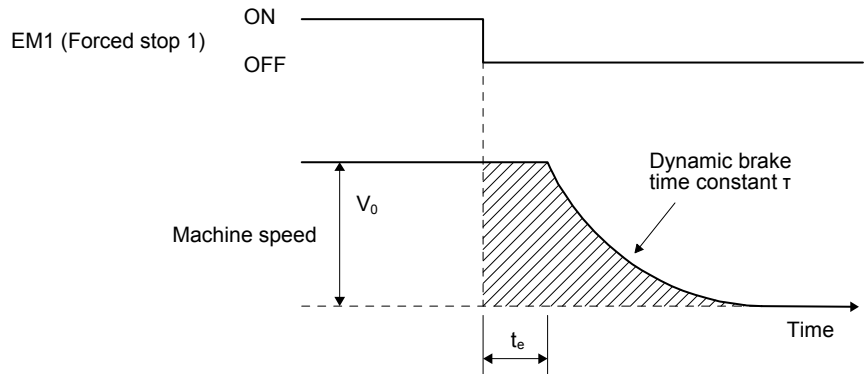

Fig. 18.2 Dynamic brake operation diagram

$$L_{\max} = \frac{V_0}{60} \cdot \left\{ t_e + \tau \left(1 + \frac{J_L}{J_M} \right) \right\} \dots \dots \dots (18.1)$$

L_{\max} : Maximum coasting distance
[mm]

V_0 : Machine's fast feed speed [mm/min]

J_M : Moment of inertia of the servo motor [$\times 10^{-4} \text{ kg}\cdot\text{m}^2$]

J_L : Load moment of inertia converted into equivalent value on servo motor shaft [$\times 10^{-4} \text{ kg}\cdot\text{m}^2$]

τ : Dynamic brake time constant [s]

t_1 : Delay time of control section [s]

The processing delay time about 3.5 ms.

(b) Dynamic brake time constant

The following shows necessary dynamic brake time constant τ for equation (18.1).

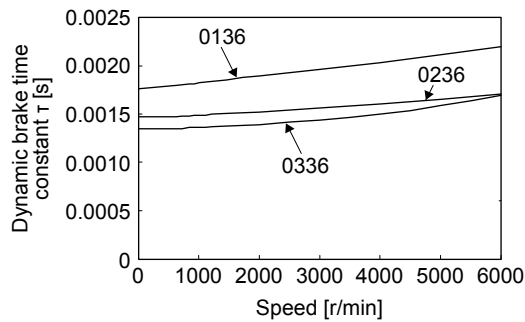

HG-AK series

18. MR-J4W2-0303B6 SERVO AMPLIFIER

(2) Permissible load to motor inertia when the dynamic brake is used

Use the dynamic brake under the load to motor inertia ratio indicated in the following table. If the ratio is higher than this value, the servo amplifier and the servo motor may burn. If there is a possibility that the ratio may exceed the value, contact your local sales office.

The values of the permissible load to motor inertia ratio in the table are the values at the maximum rotation speed of the servo motor.

| Servo motor | Permissible load to motor inertia ratio [multiplier] |
|-------------|------------------------------------------------------|
| HG-AK0136 | 30 |
| HG-AK0236 | |
| HG-AK0336 | |

18.7.4 Inrush currents at power-on of main circuit and control circuit

POINT

- The inrush current values can change depending on frequency of turning on/off the power and ambient temperature.

Since large inrush currents flow in the power supplies, use circuit protector. For circuit protectors, it is recommended that the inertia delay type, which is not tripped by an inrush current, be used. Refer to section 18.8.4 for details of the circuit protector.

This following table indicates the inrush current (reference data) when the power of output side of power unit is turned on in the conditions: main circuit of 55.2 V DC, control circuit of 26.4 V DC, and wiring length of 1 m.

| Servo amplifier | Inrush current | |
|-----------------|-------------------------------------------|-------------------------------------------------|
| | Main circuit power supply (PM/0) | Control circuit power supply (24/0) |
| MR-J4W2-0303B6 | 220 A (attenuated to approx. 2 A in 1 ms) | 600 mA (attenuated to approx. 100 mA in 500 ms) |

18. MR-J4W2-0303B6 SERVO AMPLIFIER

18.8 Options and peripheral equipment

WARNING

- Before connecting options and peripheral equipment, turn off the power and wait until the charge lamp turns off. Otherwise, an electric shock may occur. In addition, when confirming whether the charge lamp is off or not, always confirm it from the front of the servo amplifier.

CAUTION

- Use the specified peripheral equipment and options to prevent a malfunction or a fire.

POINT

- We recommend using HIV wires to wire the servo amplifiers, options, and peripheral equipment. Therefore, the recommended wire sizes may differ from those used for the previous servo amplifiers.

The items in the following table are the same as those for MR-J4W2-_B and MR-J4W3-_B servo amplifiers. Refer to the section of the detailed explanation field for details.

| Item | Detailed explanation |
|----------------------------------|----------------------|
| SSCNET III cable | Section 11.1.2 |
| Battery | Section 11.3 |
| MR Configurator2 | Section 11.4 |
| Relay (recommended) | Section 11.8 |
| Noise reduction techniques | Section 11.9 |
| Junction terminal block MR-TB26A | Section 11.12 |

18. MR-J4W2-0303B6 SERVO AMPLIFIER

18.8.1 Cable/connector sets

POINT

● The IP rating indicated for cables and connectors is their protection against ingress of dust and raindrops when they are connected to a servo amplifier or servo motor. If the IP rating of the cable, connector, servo amplifier and servo motor vary, the overall IP rating depends on the lowest IP rating of all components.



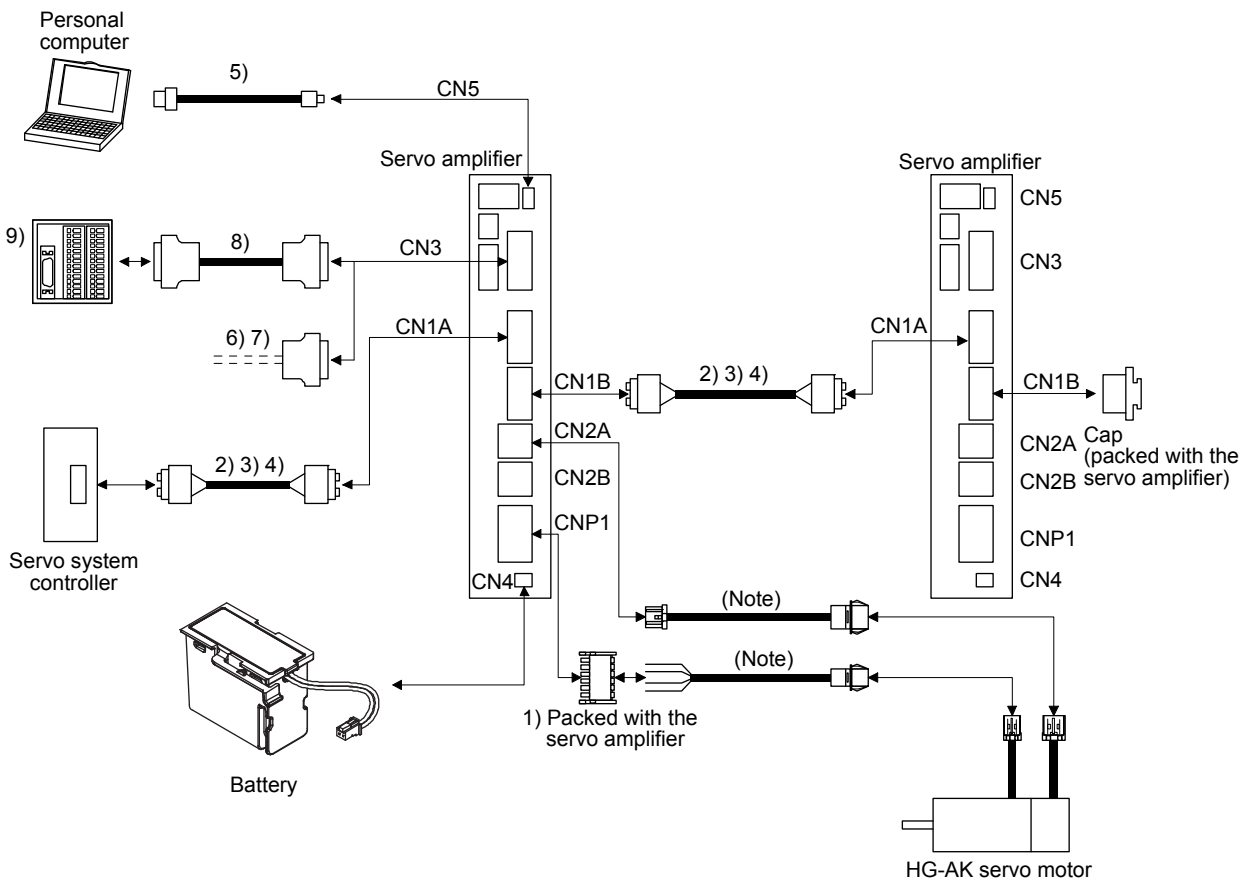

Please purchase the cable and connector options indicated in this section for the servo motor.

18.8.2 Combinations of cable/connector sets



Note. Refer to "Servo Motor Instruction Manual (Vol. 3)" for servo motor power cables and encoder cables.

18. MR-J4W2-0303B6 SERVO AMPLIFIER

| No. | Product name | Model | Description | | Remark |
|-----|-------------------------------|-----------------------------------------------------------------------------|----------------------------------------------------------------------------------------------------------------------------------------------------------------------------------------------------------------|-----------------------------------------------------------------------------------------------------------|--------------------------------------------------------|
| 1) | CNP1 connector | |  DFMC 1,5/ 6-ST-3,5-LR or equivalent (Phoenix Contact) Applicable wire size: AWG 24 to 16 Insulator OD: to 2.9 mm | | Supplied with servo amplifier |
| 2) | SSCNET III cable | MR-J3BUS_M Cable length: 0.15 m to 3 m (Refer to section 11.1.2.) | Connector: PF-2D103 (JAE) | Connector: PF-2D103 (JAE) | Standard cord inside cabinet |
| 3) | SSCNET III cable | MR-J3BUS_M-A Cable length: 5 m to 20 m (Refer to section 11.1.2.) |  | | Standard cable outside cabinet |
| 4) | SSCNET III cable | MR-J3BUS_M-B Cable length: 30 m to 50 m (Refer to section 11.1.2.) | Connector: CF-2D103-S (JAE) | Connector: CF-2D103-S (JAE) | Long-distance cable |
| 5) | USB cable | MR-J3USBCBL3M Cable length: 3 m | CN5 connector mini-B connector (5 pins) | Personal computer connector A connector | For connection with PC-AT compatible personal computer |
| 6) | Connector set | MR-J2CMP2 |  | Connector: 10126-3000PE Shell kit: 10326-52F0-008 (3M or equivalent) | Quantity: 1 |
| 7) | Connector set | MR-ECN1 |  | Connector: 10126-3000PE Shell kit: 10326-52F0-008 (3M or equivalent) | Quantity: 20 |
| 8) | Junction terminal block cable | MR-TBNATBL_M Cable length: 0.5,1 m (Refer to section 11.12) | Junction terminal block connector Connector: 10126-6000EL Shell kit: 10326-3210-000 (3M or equivalent) | Servo amplifier-side connector Connector: 10126-6000EL Shell kit: 10326-3210-000 (3M or equivalent) | For junction terminal block connection |
| 9) | Junction terminal block | MR-TB26A | Refer to section 11.12. | | |

18. MR-J4W2-0303B6 SERVO AMPLIFIER

18.8.3 Selection example of wires

| POINT |
|----------------------------------------------------------------------------------------------------------------------------------------------------------------------------------------------------------------------------------------------------------------------------------------------------------------------------------------------------------------------------------------------------------------------------------------------------------------------------------------------------------------------------------------------------------------------------------------------------------------------------------------------------------------------------------------------------------------------------------------------------------------------------------------|
| <ul style="list-style-type: none"> ● Refer to section 11.1.2 for SSCNET III cable. ● To comply with the IEC/EN/UL/CSA standard, use the wires shown in app. 4 for wiring. To comply with other standards, use a wire that is complied with each standard. ● Selection conditions of wire size are as follows. <ul style="list-style-type: none"> Construction condition: Single wire set in midair Wire length: 30 m or less <p>The voltage drops because of the cable conductor resistance. Especially for main circuit/control circuit power supply wiring, wire to secure the required input voltage at servo amplifier input section. It is recommended that the cable length be as short as possible.</p> |

(1) Wires for power supply wiring

The following diagram shows the wires used for wiring. Use the wires or equivalent given in this section.

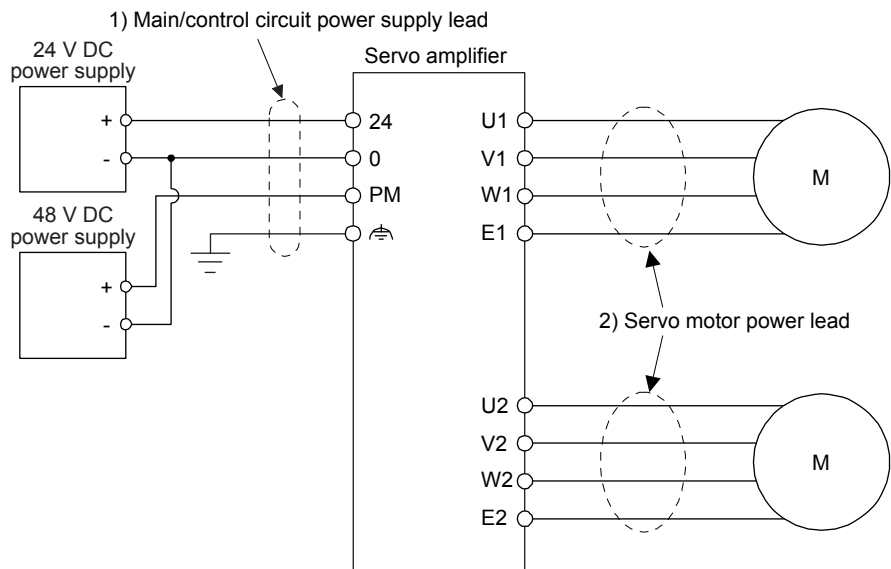

The following shows the wire size selection example.

Table 18.4 Wire size selection example (HIV wire)

| Servo amplifier | Wire [mm ²] | |
|-----------------|-------------------------|-----------------------------------------|
| | 1) 24/0/PM/⏏ | 2) U1/V1/W1/E1 U2/V2/W2/E2 (Note) |
| MR-J4W2-0303B6 | AWG 16 | AWG 19 |

Note. The wire size shows applicable size of the servo amplifier connector. For wires connecting to the servo motor, refer to "Servo Motor Instruction Manual (Vol. 3)".

18. MR-J4W2-0303B6 SERVO AMPLIFIER

18.8.4 Circuit protector

| Power supply specification | Circuit protector (Note) |
|----------------------------------------|--------------------------|
| Control circuit power supply (24 V DC) | CP30-BA 1P 1-M 1A |
| Main circuit power supply (48 V DC) | CP30-BA 1P 1-M 5A |
| Main circuit power supply (24 V DC) | CP30-BA 1P 1-M 10A |

Note. For operation characteristics, use an intermediate speed type.

APPENDIX

APPENDIX

App. 1 Auxiliary equipment manufacturer (for reference)

Names given in the table are as of October 2017.

For information, such as the delivery time, price, and specifications of the recommended products, contact each manufacturer.

| Manufacturer | Contact information |
|---------------------|---------------------------------------------------------------|
| NEC TOKIN | NEC TOKIN Corporation |
| Kitagawa Industries | Kitagawa Industries Co., Ltd. |
| JST | J.S.T. Mfg. Co., Ltd. |
| Junkosha | Purchase from Toa Electric Industrial Co. Ltd., Nagoya Branch |
| 3M | 3M |
| SEIWA ELECTRIC | Seiwa Electric Mfg. Co. Ltd. |
| Soshin Electric | Soshin Electric Co., Ltd. |
| TE Connectivity | TE Connectivity Ltd. Company |
| TDK | TDK Corporation |
| Molex | Molex |

App. 2 Handling of AC servo amplifier batteries for the United Nations Recommendations on the Transport of Dangerous Goods

United Nations Recommendations on the Transport of Dangerous Goods Rev. 15 (hereinafter Recommendations of the United Nations) has been issued. To reflect this, transport regulations for lithium metal batteries are partially revised in the Technical Instruction (ICAO-TI) by the International Civil Aviation Organization (ICAO) and the International Maritime Dangerous Goods Code (IMDG Code) by the International Maritime Organization (IMO).

To comply the instruction and code, we have modified the indication on the package for general-purpose AC servo batteries.

The above change will not affect the function and performance of the product.

(1) Target model

(a) Battery (cell)

| Model | Option model | Type | Lithium content | Mass of battery | Remark |
|---------|--------------|------|-----------------|-----------------|-------------------------------------------------------------------------------------------------------------------------------------|
| ER6 | MR-J3BAT | Cell | 0.65 g | 16 g | Cells with more than 0.3 grams of lithium content must be handled as dangerous goods (Class 9) depending on packaging requirements. |
| ER17330 | MR-BAT | Cell | 0.48 g | 13 g | |
| | A6BAT | Cell | 0.48 g | 13 g | |

APPENDIX

(b) Battery unit (assembled battery)

| Model | Option model | Type | Lithium content | Mass of battery | Remark |
|----------|------------------|---------------------------|-----------------|-----------------|----------------------------------------------------------------------------------------------------------------------------------------------------|
| ER6 | MR-J2M-BT | Assembled battery (Seven) | 4.55 g | 112 g | Assembled batteries with more than two grams of lithium content must be handled as dangerous goods (Class 9) regardless of packaging requirements. |
| CR17335A | MR-BAT6V1 | Assembled battery (Two) | 1.20 g | 34 g | Assembled batteries with more than 0.3 grams of lithium content must be handled as dangerous goods (Class 9) depending on packaging requirements. |
| | MR-BAT6V1SET(-A) | Assembled battery (Two) | 1.20 g | 34 g | |
| | MR-BAT6V1BJ | Assembled battery (Two) | 1.20 g | 34 g | |

(2) Purpose

Safer transportation of lithium metal batteries.

(3) Change in regulations

The following points are changed for lithium metal batteries in transportation by sea or air based on the revision of Recommendations of the United Nations Rev. 15 and ICAO-TI 2009-2010 edition, and IATA Dangerous Goods Regulations 54th Edition (effective January 1, 2013). For lithium metal batteries, cells are classified as UN3090, and batteries contained in or packed with equipment are classified as UN3091.

(a) Transportation of lithium metal batteries alone

| Packaging requirement | Classification | Main requirement |
|-------------------------------------------------------------------------------------------|-------------------------|-----------------------------------------------------------------------------------------------------------------------------------------------------------------------------------------------------------------------------------------------|
| Less than eight cells per package with less than one gram of lithium content | UN3090 PI968 Section II | The package must pass a 1.2 m drop test, and the handling label with battery illustration (size: 120 × 110 mm) must be attached on the package. |
| Less than two assembled batteries per package with less than two grams of lithium content | | |
| More than eight cells per package with less than one gram of lithium content | UN3090 PI968 Section IB | The package must pass a 1.2 m drop test, and the handling label with battery illustration (size: 120 × 110 mm) must be attached on the package. The Class 9 hazard label must be attached or others to comply with dangerous goods (Class 9). |
| More than two assembled batteries per package with less than two grams of lithium content | | |
| Cells with more than one gram of lithium content | UN3090 PI968 Section IA | The package must be compliant with Class 9 Packages, and the Class 9 hazard label must be attached or others to comply with dangerous goods (Class 9). |
| Assembled batteries with more than two grams of lithium content | | |

APPENDIX

(b) Transportation of lithium metal batteries packed with or contained in equipment

1) For batteries packed with equipment, follow the necessary requirements of UN3091 PI969.

Batteries are classified into either Section II/Section I depending on the lithium content/packaging requirements.

2) For batteries contained in equipment, follow the necessary requirements of UN3091 PI970.

Batteries are classified into either Section II/Section I depending on the lithium content/packaging requirements.

The special handling may be unnecessary depending on the number of batteries and gross mass per package.



Fig. app. 1 Example of Mitsubishi label with battery illustration

(Available until December 31, 2018)

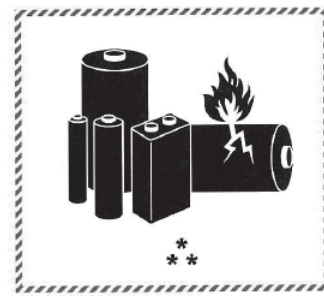

* Place for UN number (s)
** Place for telephone number for additional information

Fig. app. 2 Example of Mitsubishi label with battery illustration

(Available from January 1, 2017)

The handling label shown in Fig. app. 1 has been changed to the one shown in Fig. app. 2 in accordance with the IATA Dangerous Goods Regulations 58th Edition (effective January 1, 2017). However, the label shown in Fig. app. 1 may be used until December 31, 2018 (for two years as an interim measure).

(4) Details of the package change

The following caution is added to the packages of the target batteries.

"Containing lithium metal battery. Regulations apply for transportation."

(5) Transportation precaution for customers

For sea or air transportation, attaching the handling label (fig. app. 1) must be attached to the package of a Mitsubishi Electric cell or battery. In addition, attaching it to the outer package containing several packages of Mitsubishi Electric cells or batteries is also required. When the content of a package must be handled as dangerous goods (Class 9), the Shipper's Declaration for Dangerous Goods is required, and the package must be compliant with Class 9 Packages. Documentations like the handling label in the specified design and the Shipper's Declaration for Dangerous Goods are required for transportation. Please attach the documentations to the packages and the outer package.

The IATA Dangerous Goods Regulations are revised, and the requirements are changed annually. When customers transport lithium batteries by themselves, the responsibility for the cargo lies with the customers. Thus, be sure to check the latest version of the IATA Dangerous Goods Regulations.

APPENDIX

App. 3 Symbol for the new EU Battery Directive

Symbol for the new EU Battery Directive (2006/66/EC) that is plastered to general-purpose AC servo battery is explained here.



Note. This symbol mark is for EU countries only.

This symbol mark is according to the directive 2006/66/EC Article 20 Information for end-users and Annex II. Your MITSUBISHI ELECTRIC product is designed and manufactured with high quality materials and components which can be recycled and/or reused.

This symbol means that batteries and accumulators, at their end-of-life, should be disposed of separately from your household waste.

If a chemical symbol is printed beneath the symbol shown above, this chemical symbol means that the battery or accumulator contains a heavy metal at a certain concentration.

This will be indicated as follows.

Hg: mercury (0.0005%), Cd: cadmium (0.002%), Pb: lead (0.004%)

In the European Union there are separate collection systems for used batteries and accumulators. Please, dispose of batteries and accumulators correctly at your local community waste collection/recycling center.

Please, help us to conserve the environment we live in!

APPENDIX

App. 4 Compliance with global standards

App. 4.1 Terms related to safety (IEC 61800-5-2 Stop function)

STO function (Refer to IEC 61800-5-2:2007 4.2.2.2 STO.)

The MR-J4 servo amplifiers have the STO function. The STO function shuts down energy to servo motors, thus removing torque. This function electronically cuts off power supply in the servo amplifier. The servo amplifiers without the CN8 connector (such as MR-J4-03A6) do not support this function.

App. 4.2 About safety

This chapter explains safety of users and machine operators. Please read the section carefully before mounting the equipment.

App. 4.2.1 Professional engineer

Only professional engineers should mount MR-J4 servo amplifiers. Here, professional engineers should meet all the conditions below.

- (1) Persons who took a proper training of related work of electrical equipment or persons who can avoid risk based on past experience.
- (2) Persons who have read and familiarized himself/herself with this installation guide and operating manuals for the protective devices (e.g. light curtain) connected to the safety control system.

App. 4.2.2 Applications of the devices

MR-J4 servo amplifiers comply with the following standards.

- IEC/EN 61800-5-1, IEC/EN 61800-3, IEC/EN 60204-1
- ISO/EN ISO 13849-1 Category 3 PL e, IEC/EN 62061 SIL CL 3, IEC/EN 61800-5-2 (STO) (Except for MR-J4-03A6 and MR-J4W2-0303B6. Refer to section app. 4.8.1 for compatible models.)

MR-J4 servo amplifiers can be used with the MR-D30 functional safety unit, MR-J3-D05 safety logic unit, or safety PLCs. (For combinations of the servo amplifiers and MR-D30 or MR-J3-D05, refer to each servo amplifier instruction manual.)

App. 4.2.3 Correct use

Use the MR-J4 servo amplifiers within specifications. Refer to each instruction manual for specifications such as voltage, temperature, etc. Mitsubishi Electric Co. accepts no claims for liability if the equipment is used in any other way or if modifications are made to the device, even in the context of mounting and installation.



WARNING

- It takes 15 minutes maximum for capacitor discharging. Do not touch the unit and terminals immediately after power off.
- If you need to get close to the moving parts of the machine for inspection or others, ensure safety by confirming the power off, etc. Otherwise, it may cause an accident.

APPENDIX

(1) Peripheral device and power wiring

The followings are selected based on IEC/EN 61800-5-1, UL 508C, and CSA C22.2 No. 14.

(a) Power Wiring (local wiring and crimping tool)

The following table shows the stranded wire sizes [AWG] and the crimp terminal symbols rated at 75 °C/60 °C.

Table app. 1 Recommended wires

| Servo amplifier (Note 7) | 75 °C/60 °C stranded wire [AWG] (Note 2) | | | |
|-------------------------------------------------------------------------------------------------------------------|------------------------------------------|-------------|-------------|---------------------|
| | L1/L2/L3 ⊕ | L11/L21 | P+/C | U/V/W/⊕ (Note 3) |
| MR-J4-03A6/MR-J4W2-0303B6 | 19/- (Note 5) | | | 19/- (Note 6) |
| MR-J4-10_(1)/MR-J4-20_(1)/MR-J4-40_(1)/MR-J4-60_(4)/ MR-J4-70_/MR-J4-100_(4)/MR-J4-200_(4) (T)/ MR-J4-350_4 | 14/14 | 14/14 | 14/14 | 14/14 |
| MR-J4-200_(S) | 12/12 | | | |
| MR-J4-350_ | | | | 12/12 |
| MR-J4-500_ (Note 1) | 10: a/10: a | 14: c/14: c | 14: c/14: c | 10: b/10: b |
| MR-J4-700_ (Note 1) | 8: b/8: b | | 12: a/12: a | 8: b/8: b |
| MR-J4-11K_ (Note 1) | 6: d/4: f | | 12: e/12: e | 4: f/4: f |
| MR-J4-15K_ (Note 1) | 4: f/3: f | | 10: e/10: e | 3: g/2: g |
| MR-J4-22K_ (Note 1) | 1: h/-: - | | 10: i/10: i | 1: j/-: - |
| MR-J4-500_4 (Note 1) | 14: c/14: c | | 14: c/14: c | 12: a/10: a |
| MR-J4-700_4 (Note 1) | 12: a/12: a | | | 10: a/10: a |
| MR-J4-11K_4 (Note 1) | 10: e/10: e | | 14: k/14: k | 8: l/8: l |
| MR-J4-15K_4 (Note 1) | 8: l/8: l | | 12: e/12: e | 6: d/4: d |
| MR-J4-22K_4 (Note 1) | 6: m/4: m | | 12: i/12: i | 6: n/4: n |
| MR-J4W_-B | 14/14 (Note 4) | 14/14 | 14/14 | 14/14 |

- Note
- To connect these models to a terminal block, be sure to use the screws that come with the terminal block.
 - Alphabets in the table indicate crimping tools. Refer to table app. 2 for the crimp terminals and crimping tools.
 - Select wire sizes depending on the rated output of the servo motors. The values in the table are sizes based on rated output of the servo amplifiers.
 - Use the crimp terminal c for the PE terminal of the servo amplifier.
 - This value is of 24/0/PM/⊕ for MR-J4-03A6 and MR-J4W2-0303B6.
 - This value is of U/V/W/E for MR-J4-03A6 and MR-J4W2-0303B6.
 - "(S)" means 1-phase 200 V AC power input and "(T)" means 3-phase 200 V AC power input in the table.

Table app. 2 Recommended crimp terminals

| Symbol | Servo amplifier-side crimp terminals | | Manufacturer |
|------------|--------------------------------------|-----------------|-----------------------------------|
| | Crimp terminal (Note 2) | Applicable tool | |
| a | FVD5.5-4 | YNT-1210S | JST (J.S.T. Mfg. Co., Ltd.) |
| b (Note 1) | 8-4NS | YHT-8S | |
| c | FVD2-4 | YNT-1614 | |
| d | FVD14-6 | YF-1 | |
| e | FVD5.5-6 | YNT-1210S | |
| f | FVD22-6 | YF-1 | |
| g | FVD38-6 | YF-1 | |
| h | R60-8 | YF-1 | |
| i | FVD5.5-8 | YNT-1210S | |
| j | CB70-S8 | YF-1 | |
| k | FVD2-6 | YNT-1614 | |
| l | FVD8-6 | YF-1 | |
| m | FVD14-8 | YF-1 | |
| n | FVD22-8 | YF-1 | |

- Note
- Coat the crimping part with an insulation tube.
 - Some crimp terminals may not be mounted depending on the size. Make sure to use the recommended ones or equivalent ones.

APPENDIX

(b) Selection example of MCCB and fuse

Use T class fuses or molded-case circuit breaker (UL 489 Listed MCCB) as the following table. The T class fuses and molded-case circuit breakers in the table are selected examples based on rated I/O of the servo amplifiers. When you select a smaller capacity servo motor to connect it to the servo amplifier, you can also use smaller capacity T class fuses or molded-case circuit breaker than ones in the table. For selecting ones other than Class T fuses and molded-case circuit breakers below and selecting a Type E Combination motor controller, refer to section 11.6.

| Servo amplifier (100 V class) | Molded-case circuit breaker (120 V AC) | Fuse (300 V) |
|----------------------------------|----------------------------------------|--------------|
| MR-J4-10_1/MR-J4-20_1/MR-J4-40_1 | NV50-SVFU-15A (50 A frame 15 A) | 20 A |

| Servo amplifier (200 V class) (Note) | Molded-case circuit breaker (240 V AC) | Fuse (300 V) |
|----------------------------------------------------------------------------------------------------------------------------|----------------------------------------|--------------|
| MR-J4-10_/MR-J4-20_/MR-J4-40_/MR-J4-60_ (T)/MR-J4-70_ (T)/MR-J4W2-22B (T) | NF50-SVFU-5A (50 A frame 5 A) | 10 A |
| MR-J4-60_ (S)/MR-J4-70_ (S) /MR-J4-100_ (T)/MR-J4W2-22B (S)/MR-J4W2-44B (T)/MR-J4W2-77B (T)/MR-J4W3-222B/ MR-J4W3-444B (T) | NF50-SVFU-10A (50 A frame 10 A) | 15 A |
| MR-J4-100_ (S)/MR-J4-200_ (T)/MR-J4W2-44B (S)/MR-J4W2-1010B | NF50-SVFU-15A (50 A frame 15 A) | 30 A |
| MR-J4-200_ (S)/MR-J4-350_/MR-J4W2-77B (S)/MR-J4W3-444B (S) | NF50-SVFU-20A (50 A frame 20 A) | 40 A |
| MR-J4-500_ | NF50-SVFU-30A (50 A frame 30 A) | 60 A |
| MR-J4-700_ | NF50-SVFU-40A (50 A frame 40 A) | 80 A |
| MR-J4-11K_ | NF100-CVFU-60A (100 A frame 60 A) | 125 A |
| MR-J4-15K_ | NF100-CVFU-80A (100 A frame 80 A) | 150 A |
| MR-J4-22K_ | NF225-CWU-125A (225 A frame 125 A) | 300 A |

Note. "(S)" means 1-phase 200 V AC power input and "(T)" means 3-phase 200 V AC power input in the table.

| Servo amplifier (400 V class) | Molded-case circuit breaker (480 V AC) | Fuse (600 V) |
|-------------------------------|----------------------------------------|--------------|
| MR-J4-60_4/MR-J4-100_4 | NF100-HRU-5A (100 A frame 5 A) | 10 A |
| MR-J4-200_4 | NF100-HRU-10A (100 A frame 10 A) | 15 A |
| MR-J4-350_4 | NF100-HRU-10A (100 A frame 10 A) | 20 A |
| MR-J4-500_4 | NF100-HRU-15A (100 A frame 15 A) | 30 A |
| MR-J4-700_4 | NF100-HRU-20A (100 A frame 20 A) | 40 A |
| MR-J4-11K_4 | NF100-HRU-30A (100 A frame 30 A) | 60 A |
| MR-J4-15K_4 | NF100-HRU-40A (100 A frame 40 A) | 80 A |
| MR-J4-22K_4 | NF100-HRU-60A (100 A frame 60 A) | 125 A |

(c) Power supply

This servo amplifier can be supplied from star-connected supply with grounded neutral point of overvoltage category III (overvoltage category II for 1-phase servo amplifiers, MR-J4-03A6, and MR-J4W2-0303B6) set forth in IEC/EN 60664-1. For the interface power supply, use an external 24 V DC power supply with reinforced insulation on I/O terminals.

In case of MR-J4-03A6 and MR-J4W2-0303B6, use DC power supplies of reinforced insulation type to main circuit, control circuit, and UL listed (recognized) 48 V DC/24 V DC power supplies which can generate more than 1.2 A/2.4 A per axis.

APPENDIX

(d) Grounding

To prevent an electric shock, always connect the protective earth (PE) terminal (marked \oplus) of the servo amplifier to the protective earth (PE) of the cabinet. Do not connect two grounding cables to the same protective earth (PE) terminal. Always connect cables to the terminals one-to-one.

This product can cause a DC current in the protective earthing conductor. To protect direct/indirect contact using an earth-leakage current breaker (RCD), only an RCD of type B can be used for the power supply side of the product.

The MR-J4-700_4 is high protective earthing conductor current equipment, the minimum size of the protective earthing conductor must comply with the local safety regulations.



(2) EU compliance

The MR-J4 servo amplifiers are designed to comply with the following directions to meet requirements for mounting, using, and periodic technical inspections: Machinery directive (2006/42/EC), EMC directive (2014/30/EU), Low-voltage directive (2014/35/EU), and RoHS directive (2011/65/EU).

(a) EMC requirement

MR-J4 servo amplifiers comply with category C3 in accordance with EN 61800-3. As for I/O wires (max. length 10 m. However, 3 m for STO cable for CN8.) and encoder cables (max. length 50 m), use shielded wires and ground the shields. Install an EMC filter and surge protector on the primary side for input and output of 200 V class and for output of 400 V class servo amplifiers. In addition, use a line noise filter for outputs of the 11 kW and 15 kW of 400 V class servo amplifiers. The following shows recommended products.

EMC filter: Soshin Electric HF3000A-UN series, TF3000C-TX series, COSEL FTB series

Surge protector: Okaya Electric Industries RSPD series

Line noise filter: Mitsubishi Electric FR-BLF

MR-J4 Series are not intended to be used on a low-voltage public network which supplies domestic premises; radio frequency interference is expected if used on such a network. The installer shall provide a guide for Installation and use, including recommended mitigation devices. To avoid the risk of crosstalk to signal cables, the installation instructions shall either recommend that the power interface cable be segregated from signal cables.

Use the DC power supply installed with the amplifiers in the same cabinet. Do not connect the other electric devices to the DC power supply.

(b) For Declaration of Conformity (DoC)

Hereby, MITSUBISHI ELECTRIC EUROPE B.V. declares that the servo amplifiers are in compliance with the necessary requirements and standards (2006/42/EC, 2014/30/EU, 2014/35/EU and 2011/65/EU). For the copy of Declaration of Conformity, contact your local sales office.

APPENDIX

(3) USA/Canada compliance

This servo amplifier is designed in compliance with UL 508C and CSA C22.2 No. 14.

(a) Installation

The minimum cabinet size is 150% of each MR-J4 servo amplifier's volume. Also, design the cabinet so that the ambient temperature in the cabinet is 55 °C or less. The servo amplifier must be installed in the metal cabinet. Additionally, mount the servo amplifier on a cabinet that the protective earth based on the standard of IEC/EN 60204-1 is correctly connected. For environment, the units should be used in open type (UL 50) and overvoltage category shown in table in section app. 4.8.1. The servo amplifier needs to be installed at or below pollution degree 2. For connection, use copper wires.

(b) Short-circuit current rating (SCCR)

Suitable For Use On A Circuit Capable Of Delivering Not More Than 100 kA rms Symmetrical Amperes, 500 Volts Maximum (Not More Than 5 kA rms Symmetrical Amperes, 48 Volts Maximum for MR-J4-03A6 and MR-J4W2-0303B6). For SCCR when using a Type E Combination motor controller, refer to section 11.6.

(c) Overload protection characteristics

The MR-J4 servo amplifiers have solid-state servo motor overload protection. (It is set on the basis (full load current) of 120% rated current of the servo amplifier.)

(d) Over-temperature protection for motor

Motor Over temperature sensing is not provided by the drive.

Integral thermal protection(s) is necessary for motor and refer to app. 4.4 for the proper connection.

(e) Branch circuit protection

For installation in United States, branch circuit protection must be provided, in accordance with the National Electrical Code and any applicable local codes.

For installation in Canada, branch circuit protection must be provided, in accordance with the Canada Electrical Code and any applicable provincial codes.

(4) South Korea compliance

This product complies with the Radio Wave Law (KC mark). Please note the following to use the product.

이 기기는 업무용 (A급) 전자파적합기기로서 판매자 또는 사용자는 이 점을 주의하시기 바라며, 가정외의 지역에서 사용하는 것을 목적으로 합니다.

(The product is for business use (Class A) and meets the electromagnetic compatibility requirements. The seller and the user must note the above point, and use the product in a place except for home.)

In addition, use an EMC filter, surge protector, ferrite core, and line noise filter on the primary side for inputs. Use a ferrite core and line noise filter for outputs. Use a distance greater than 30 m between the product and third party sensitive radio communications for an MR-J4-22K_(4).

APPENDIX

App. 4.2.4 General cautions for safety protection and protective measures

Observe the following items to ensure proper use of the MR-J4 servo amplifiers.

- (1) For safety components and installing systems, only qualified personnel and professional engineers should perform.
- (2) When mounting, installing, and using the MELSERVO MR-J4 servo amplifier, always observe standards and directives applicable in the country.
- (3) The item about noises of the test notices in the manuals should be observed.

App. 4.2.5 Residual risk

- (1) Be sure that all safety related switches, relays, sensors, etc., meet the required safety standards.
- (2) Perform all risk assessments and safety level certification to the machine or the system as a whole.
- (3) If the upper and lower power modules in the servo amplifier are shorted and damaged simultaneously, the servo motor may make a half revolution at a maximum.
- (4) Only qualified personnel are authorized to install, start-up, repair or service the machines in which these components are installed. Only trained engineers should install and operate the equipment. (ISO 13849-1 Table F.1 No. 5)
- (5) Separate the wiring for safety observation function from other signal wirings. (ISO 13849-1 Table F.1 No. 1)
- (6) Protect the cables with appropriate ways (routing them in a cabinet, using a cable guard, etc.).
- (7) Keep the required clearance/creepage distance depending on voltage you use.

App. 4.2.6 Disposal

Disposal of unusable or irreparable devices should always occur in accordance with the applicable country-specific waste disposal regulations. (Example: European Waste 16 02 14)

App. 4.2.7 Lithium battery transportation

To transport lithium batteries, take actions to comply with the instructions and regulations such as the United Nations (UN), the International Civil Aviation Organization (ICAO), and the International Maritime Organization (IMO).

The batteries (MR-BAT6V1SET, MR-BAT6V1SET-A, MR-BAT6V1, and MR-BAT6V1BJ) are assembled batteries from two batteries (lithium metal battery CR17335A) which are not subject to the dangerous goods (Class 9) of the UN Recommendations.

APPENDIX

App. 4.3 Installation direction and clearances

CAUTION

- The devices must be installed in the specified direction. Not doing so may cause a malfunction.
- Mount the servo amplifier on a cabinet which meets IP54 in the correct direction to maintain pollution degree 2.
- The regenerative resistor supplied with 11 kW to 22 kW servo amplifiers does not have a protective cover. Touching the resistor (including wiring/screw hole area) may cause a burn injury and electric shock. Even if the power was shut-off, be careful until the bus voltage discharged and the temperature decreased because of the following reasons.
 - It may cause a burn injury due to very high temperature without cooling.
 - It may cause an electric shock due to charged capacitor of the servo amplifier.

To adapt your machine using MR-J4-03A6 or MR-J4W2-0303B6 to IEC/EN 60950-1, either supply the amplifier with a power supply complying with the requirement of 2.5 stated in IEC/EN 60950-1 (Limited Power Source), or cover the amplifier and motors connected to the outputs with a fire enclosure.

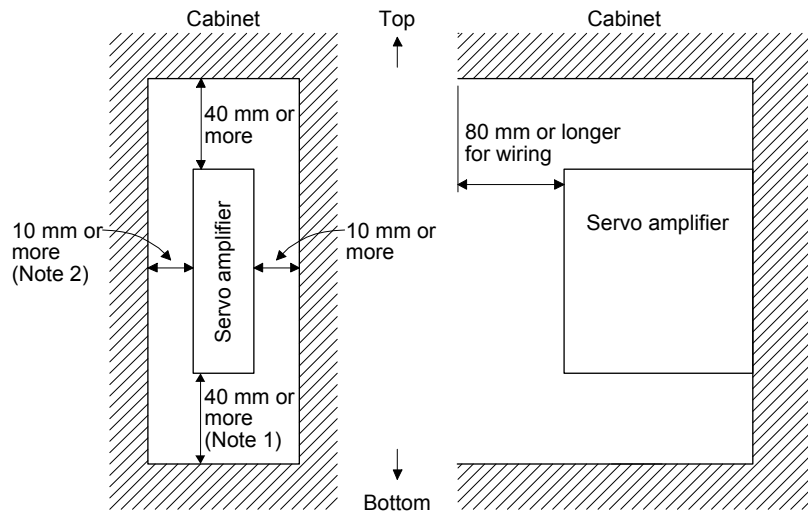

- Note 1. For 11 kW to 22 kW servo amplifiers, the clearance between the bottom and ground will be 120 mm or more.
- Note 2. When mounting MR-J4-500_, maintain a minimum clearance of 25 mm on the left side.

APPENDIX

App. 4.4 Electrical Installation and configuration diagram

⚠ WARNING ● Turn off the molded-case circuit breaker (MCCB) to avoid electrical shocks or damages to the product before starting the installation or wiring.

⚠ CAUTION ● The installation complies with IEC/EN 60204-1. The voltage supply to machines must be 20 ms or more of tolerance against instantaneous power failure as specified in IEC/EN 60204-1.

● Connecting a servo motor for different axis to U, V, W, or CN2_ of the servo amplifier may cause a malfunction.

● Securely connect the cables in the specified method and tighten them with the specified torque. Otherwise, the servo motor may operate unexpectedly.

The following shows representative configuration examples to conform to the IEC/EN/UL/CSA standards.

(1) 3-phase input for MR-J4 1-axis servo amplifier

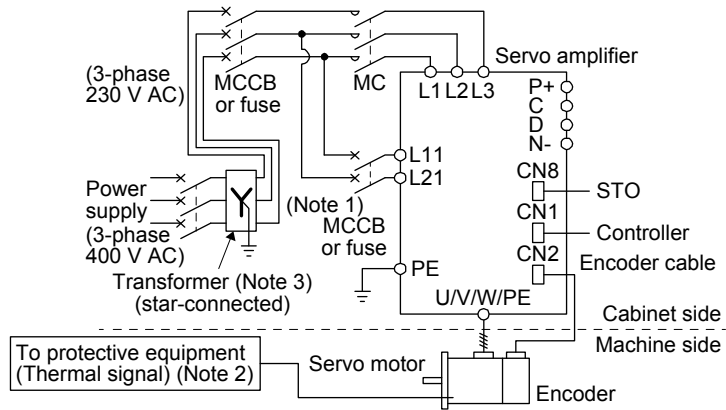

- Note 1. When the wire sizes of L1 and L11 are the same, MCCB or fuse is not required.
- Note 2. Please use a thermal sensor, etc. for thermal protection of the servo motor.
- Note 3. For 400 V class, a step-down transformer is not required.

APPENDIX

(2) 1-phase input for MR-J4 1-axis servo amplifier

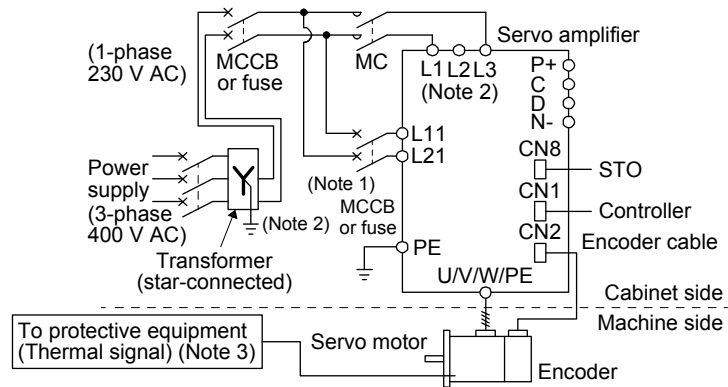

- Note 1. When the wire sizes of L1 and L11 are the same, MCCB or fuse is not required.
- Note 2. When using a 100 V class servo amplifier, step down the power supply voltage to 100 V and connect the main circuit power supply lines to L1 and L2. For 1-phase 200 V AC servo amplifiers, connect the lines to L1 and L3.
- Note 3. Please use a thermal sensor, etc. for thermal protection of the servo motor.

(3) Main circuit 48 V DC input for MR-J4 1-axis servo amplifier

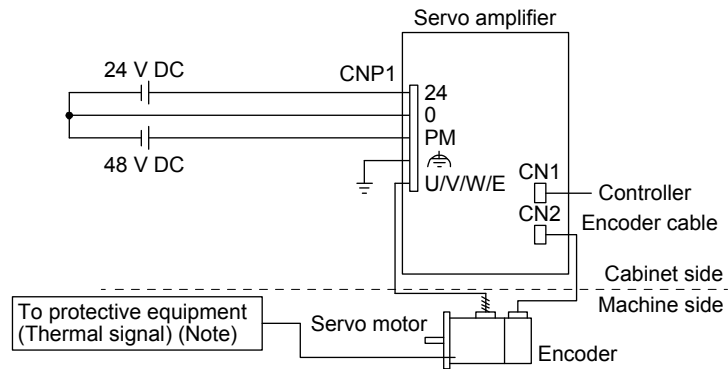

Note. Please use a thermal sensor, etc. for thermal protection of the servo motor.

The connectors described by rectangles are safely separated from the main circuits described by circles. The connected motors will be limited as follows.

- (1) HG/HF/HC/HA series servo motors (Mfg.: Mitsubishi Electric)
- (2) Using a servo motor complied with IEC 60034-1 and Mitsubishi Electric encoder (OBA, OSA)

APPENDIX

App. 4.5 Signal

App. 4.5.1 Signal

The following shows MR-J4-10B signals as a typical example. For other servo amplifiers, refer to each servo amplifier instruction manual.

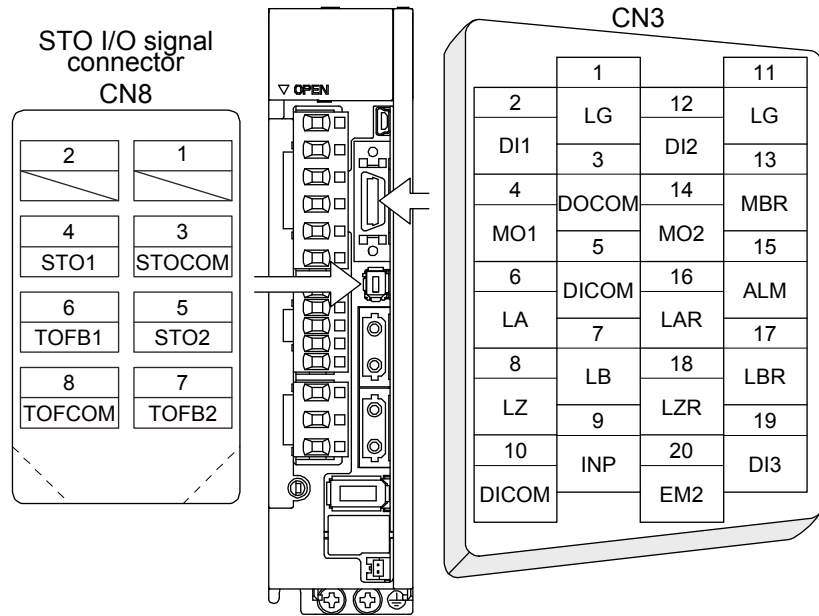

App. 4.5.2 I/O device

Input device

| Symbol | Device | Connector | Pin No. |
|--------|---------------------------------------------|-----------|---------|
| EM2 | Forced stop 2 | CN3 | 20 |
| STOCOM | Common terminal for input signals STO1/STO2 | CN8 | 3 |
| STO1 | STO1 state input | | 4 |
| STO2 | STO2 state input | | 5 |

Output device

| Symbol | Device | Connector | Pin No. |
|--------|--------------------------------------------------------|-----------|---------|
| TOFCOM | Common terminal for monitor output signal in STO state | CN8 | 8 |
| TOFB1 | Monitor output signal in STO1 state | | 6 |
| TOFB2 | Monitor output signal in STO2 state | | 7 |

Power supply

| Symbol | Device | Connector | Pin No. |
|--------|--------------------------------|-----------|---------|
| DICOM | Digital I/F power supply input | CN3 | 5, 10 |
| DOCOM | Digital I/F common | | 3 |
| SD | Shield | | Plate |

APPENDIX

App. 4.6 Maintenance and service

 **WARNING** ● To avoid an electric shock, only qualified personnel should attempt inspections. For repair and parts replacement, contact your local sales office.

App. 4.6.1 Inspection items

It is recommended that the following points periodically be checked.

- (1) Check for loose terminal block screws. Retighten any loose screws. (Except for MR-J4-03A6 and MR-J4W2-0303B6)

| Servo amplifier | Tightening torque [N•m] | | | | | | | | | | | | | |
|---------------------------------------------------------------------------------------------------------------------|-------------------------|----|----|----|----|----|----|---|-----|-----|-----|---|---|---|
| | L1 | L2 | L3 | N- | P3 | P4 | P+ | C | D | L11 | L21 | U | V | W |
| MR-J4-10_(1)/MR-J4-20_(1)/ MR-J4-40_(1)/MR-J4-60_(4)/ MR-J4-70_/MR-J4-100_(4)/ MR-J4-200_(4)/MR-J4-350_(4) | 1.2 | | | | | | | | | | | | | |
| MR-J4-500_ | 1.2 | | | | | | | | 0.8 | | 1.2 | | | |
| MR-J4-700_(4)/MR-J4-500_4 | 1.2 | | | | | | | | 0.8 | | 1.2 | | | |
| MR-J4-11K_(4)/MR-J4-15K_(4) | 3.0 | | | | | | | | 1.2 | | 3.0 | | | |
| MR-J4-22K_(4) | 6.0 | | | | | | | | 1.2 | | 6.0 | | | |
| MR-J4W_-_B | 1.2 | | | | | | | | | | | | | |

- (2) Servo motor bearings, brake section, etc. for unusual noise.
- (3) Check the cables and the like for scratches or cracks. Perform periodic inspection according to operating conditions.
- (4) Check that the connectors are securely connected to the servo motor.
- (5) Check that the wires are not coming out from the connector.
- (6) Check for dust accumulation on the servo amplifier.
- (7) Check for unusual noise generated from the servo amplifier.
- (8) Check the servo motor shaft and coupling for connection.
- (9) Make sure that the emergency stop circuit operates properly such that an operation can be stopped immediately and a power is shut off by the emergency stop switch.

APPENDIX

App. 4.6.2 Parts having service life

Service life of the following parts is listed below. However, the service life varies depending on operation and environment. If any fault is found in the parts, they must be replaced immediately regardless of their service life. For parts replacement, please contact your local sales office.

| Part name | Life guideline |
|------------------------------|-------------------------------------------------------------------------------------------------------------------------------------|
| Smoothing capacitor | (Note 3) 10 years |
| Relay | Number of power-on, forced stop and controller forced stop times: 100,000 times Number of on and off for STO: 1,000,000 times |
| Cooling fan | 10,000 hours to 30,000 hours (2 years to 3 years) |
| (Note 1) Battery backup time | Approximately 20,000 hours (equipment power supply: off, ambient temperature: 20 °C) |
| (Note 2) Battery life | 5 years from date of manufacture |

- Note
1. The time is for using MR-J4 1-axis servo amplifier with an rotary servo motor using MR-BAT6V1SET, MR-BAT6V1SET-A, or MR-BAT6V1BJ. For details and other battery backup time, refer to chapter 12.
 2. Quality of the batteries degrades by the storage condition. The battery life is 5 years from the production date regardless of the connection status.
 3. The characteristic of smoothing capacitor is deteriorated due to ripple currents, etc. The life of the capacitor greatly depends on ambient temperature and operating conditions. The capacitor will be the end of its life in 10 years of continuous operation in air-conditioned environment (surrounding air temperature of 40 °C or less for use at the maximum 1000 m above sea level, 30 °C or less for over 1000 m to 2000 m).

APPENDIX

App. 4.7 Transportation and storage

| | |
|--------------------------------------------------------------------------------------------------|-----------------------------------------------------------------------------------------------------------------------------------------------------------------------------------------------------------------------------------------------------------------------------------------------------------------------------------------------------------------------------------------------------------------------------------------------------------------------------------------------------------------------------------------------------------------------------------------------------------------------------------------|
|  CAUTION | <ul style="list-style-type: none"> ● Transport the products correctly according to their mass. ● Stacking in excess of the limited number of product packages is not allowed. ● Do not hold the front cover, cables, or connectors when carrying the servo amplifier. Otherwise, it may drop. ● For detailed information on transportation and handling of the battery, refer to app. 2 and app. 3. ● Install the product in a load-bearing place of servo amplifier and servo motor in accordance with the instruction manual. ● Do not put excessive load on the machine. |
|--------------------------------------------------------------------------------------------------|-----------------------------------------------------------------------------------------------------------------------------------------------------------------------------------------------------------------------------------------------------------------------------------------------------------------------------------------------------------------------------------------------------------------------------------------------------------------------------------------------------------------------------------------------------------------------------------------------------------------------------------------|

When you keep or use it, please fulfill the following environment.

| Item | | Environment |
|----------------------|------------------------------------|----------------------------------------------------------------------------------------------------------------------------------------------------------------------------|
| Ambient temperature | Operation [°C] | 0 to 55 Class 3K3 (IEC/EN 60721-3-3) |
| | Transportation (Note) [°C] | -20 to 65 Class 2K4 (IEC/EN 60721-3-2) |
| | Storage (Note) [°C] | -20 to 65 Class 1K4 (IEC/EN 60721-3-1) |
| Ambient humidity | Operation, transportation, storage | 5 %RH to 90 %RH |
| Vibration resistance | Test condition | 10 Hz to 57 Hz with constant amplitude of 0.075 mm 57 Hz to 150 Hz with constant acceleration of 9.8 m/s ² to IEC/EN 61800-5-1 (Test Fc of IEC 60068-2-6) |
| | Operation | 5.9 m/s ² |
| | Transportation (Note) | Class 2M3 (IEC/EN 60721-3-2) |
| | Storage | Class 1M2 (IEC/EN 60721-3-2) |
| Pollution degree | | 2 |
| IP rating | | IP20 (IEC/EN 60529), Terminal block IP00 |
| | | Open type (UL 50) |
| Altitude | Operation, storage | Max. 2000 m above sea level |
| | Transportation | Max. 10000 m above sea level |

Note. In regular transport packaging

APPENDIX

App. 4.8 Technical data

App. 4.8.1 MR-J4 servo amplifier

| | | | | | | |
|-------------------------------------------------------------|--------------------------------|-----------------------------------------------------------------------------------------------------------------------------------------------------------------------------------|---------------------------------------------------------------------------------------------------------|-------------------------------------------------|--------------------------------------------------------------------------------------------------------------------------------------------|-------------------------------|
| Item | | MR-J4-10_/ MR-J4-20_/ MR-J4-40_/ MR-J4-60_/ MR-J4-70_/ MR-J4-100_/ MR-J4-200_/ MR-J4W2-22B/ MR-J4W2-44B/ MR-J4W2-77B/ MR-J4W3-222B/ MR-J4W3-444B | MR-J4-350_/ MR-J4-500_/ MR-J4-700_/ MR-J4W2-1010B/ MR-J4-11K_/ MR-J4-15K_/ MR-J4-22K_ | MR-J4-10_1/ MR-J4-20_1/ MR-J4-40_1 | MR-J4-60_4/ MR-J4-100_4/ MR-J4-200_4/ MR-J4-350_4/ MR-J4-500_4/ MR-J4-700_4/ MR-J4-11K_4/ MR-J4-15K_4/ MR-J4-22K_4 | MR-J4-03A6/ MR-J4W2-0303B6 |
| Power supply | Main circuit (line voltage) | 3-phase or 1-phase 200 V AC to 240 V AC, 50 Hz/60 Hz (Note 2) | 3-phase 200 V AC to 240 V AC, 50 Hz/60 Hz (Note 2) | 1-phase 100 V AC to 120 V AC, 50 Hz/60 Hz | 3-phase 380 V AC to 480 V AC, 50 Hz/60 Hz | 48 V DC or 24 V DC |
| | Control circuit (line voltage) | 1-phase 200 V AC to 240 V AC, 50/60 Hz (Note 2) | | 1-phase 100 V AC to 120 V AC, 50 Hz/60 Hz | 1-phase 380 V AC to 480 V AC, 50 Hz/60 Hz | 24 V DC |
| | Interface (SELV) | 24 V DC (required current capacity: MR-J4-_A_, 500 mA; MR-J4-_B_, 300 mA; MR-J4W2-_B_, 350 mA; MR-J4W3-_B_, 450 mA; MR-J4-_GF_, 300 mA) | | | | |
| Control method | | Sine-wave PWM control, current control method | | | | |
| Safety observation function (STO) IEC/EN 61800-5-2 (Note 3) | | EN ISO 13849-1 Category 3 PL e, IEC 61508 SIL 3, EN 62061 SIL CL 3, and EN 61800-5-2 | | | | |
| Mean time to dangerous failure | | MTTFd ≥ 100 [years] (314a) | | | | |
| Effectiveness of fault monitoring of a system or subsystem | | DC = Medium, 97.6 [%] | | | | |
| Average probability of dangerous failures per hour | | PFH = 6.4 × 10 ⁻⁹ [1/h] | | | | |
| Mission time | | T _M = 20 [years] | | | | |
| Response performance | | 8 ms or less (STO input off → energy shut off) | | | | |
| Pollution degree | | 2 (IEC/EN 60664-1) | | | | |
| Overvoltage category | | 1-phase 100 V AC/200 V AC: II (IEC/EN 60664-1), 3-phase 200 V AC/400 V AC: III (IEC/EN 60664-1) | | | | II (IEC/EN 60664-1) |
| Protective class | | I (IEC/EN 61800-5-1) | | | | III (IEC/EN 61800-5-1) |
| Short-circuit current rating (SCCR) | | 100 kA | | | | 5 kA (Note 1) |

- Note 1. For the use in US/Canada, constitute a branch circuit including the power supply which endures SCCR of 5 kA minimum in the industrial cabinet.
2. For MR-J4-_RJ, 283 V DC to 340 V DC are also supported.
3. Servo amplifiers manufactured in June 2015 or later comply with SIL 3 requirements. However, MR-J4-_A_/MR-J4-_B_ servo amplifiers manufactured in China comply with SIL 3 requirements from the December 2015 production.

APPENDIX

App. 4.8.2 Dimensions/mounting hole process drawing

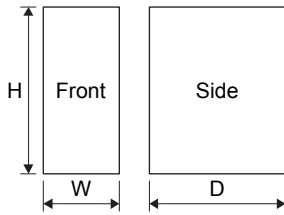

| Servo amplifier | Variable dimensions [mm] | | | Mass [kg] |
|----------------------------------|--------------------------|-----|-----------|-----------|
| | W | H | D | |
| MR-J4-03A6 | 30 | 100 | 90 | 0.2 |
| MR-J4-10_(1)/MR-J4-20_(1) (Note) | 40 (50) | 168 | 135 (155) | 0.8 (1.0) |
| MR-J4-40_(1)/MR-J4-60_(Note) | 40 (50) | 168 | 170 (155) | 1.0 |
| MR-J4-70_/MR-J4-100_ | 60 | 168 | 185 | 1.4 |
| MR-J4-200_(4) | 90 | 168 | 195 | 2.1 |
| MR-J4-350_ | 90 | 168 | 195 | 2.3 |
| MR-J4-500_ | 105 | 250 | 200 | 4.0 |
| MR-J4-700_ | 172 | 300 | 200 | 6.2 |
| MR-J4-11K_(4)/MR-J4-15K_(4) | 220 | 400 | 260 | 13.4 |
| MR-J4-22K_(4) | 260 | 400 | 260 | 18.2 |
| MR-J4-60_4/MR-J4-100_4 | 60 | 168 | 195 | 1.7 |
| MR-J4-350_4 | 105 | 250 | 200 | 3.6 |
| MR-J4-500_4 | 130 | 250 | 200 | 4.3 |
| MR-J4-700_4 | 172 | 300 | 200 | 6.5 |
| MR-J4W2-0303B6 | 30 | 168 | 100 | 0.3 |
| MR-J4W2-22B/MR-J4W2-44B | 60 | 168 | 195 | 1.4 |
| MR-J4W2-77B/MR-J4W2-1010B | 85 | 168 | 195 | 2.3 |
| MR-J4W3-222B/MR-J4W3-444B | 85 | 168 | 195 | 2.3 |

Note. The value in the parenthesis shows the value of MR-J4-_GF_.

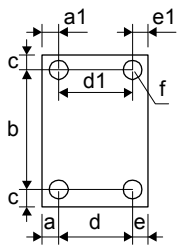

| Servo amplifier | Variable dimensions [mm] | | | | | | | | Screw size |
|------------------------------------------------------|--------------------------|----|-----------|-----|-----------|-----------|---|----|------------|
| | a | a1 | b | c | d | d1 | e | e1 | f |
| MR-J4-03A6 | | | 90 ± 0.5 | 5 | | | 4 | 4 | M4 |
| MR-J4-10_(1)/MR-J4-20_(1)/ MR-J4-40_(1)/MR-J4-60_ | 6 | 6 | 156 ± 0.5 | 6 | | | | | M5 |
| MR-J4-70_/MR-J4-100_ | 12 | 12 | 156 ± 0.5 | 6 | 42 ± 0.3 | | | | M5 |
| MR-J4-200_(4)/MR-J4-350_ | 6 | 45 | 156 ± 0.5 | 6 | 78 ± 0.3 | | | | M5 |
| MR-J4-500_ | 6 | 6 | 235 ± 0.5 | 7.5 | 93 ± 0.5 | 93 ± 0.5 | | | M5 |
| MR-J4-700_ | 6 | 6 | 285 ± 0.5 | 7.5 | 160 ± 0.5 | 160 ± 0.5 | | | M5 |
| MR-J4-11K_(4)/MR-J4-15K_(4) | 12 | 12 | 380 ± 0.5 | 10 | 196 ± 0.5 | 196 ± 0.5 | | | M5 |
| MR-J4-22K_(4) | 12 | 12 | 376 ± 0.5 | 12 | 236 ± 0.5 | 236 ± 0.5 | | | M10 |
| MR-J4-60_4/MR-J4-100_4 | 12 | 12 | 156 ± 0.5 | 6 | 42 ± 0.3 | | | | M5 |
| MR-J4-350_4 | 6 | 6 | 235 ± 0.5 | 7.5 | 93 ± 0.5 | 93 ± 0.5 | | | M5 |
| MR-J4-500_4 | 6 | 6 | 235 ± 0.5 | 7.5 | 118 ± 0.5 | 118 ± 0.5 | | | M5 |
| MR-J4-700_4 | 6 | 6 | 285 ± 0.5 | 7.5 | 160 ± 0.5 | 160 ± 0.5 | | | M5 |
| MR-J4W2-0303B6 | 6 | 6 | 156 ± 0.5 | 6 | | | | | M5 |
| MR-J4W2-22B/MR-J4W2-44B | 6 | 6 | 156 ± 0.5 | 6 | | | | | M5 |
| MR-J4W2-77B/MR-J4W2-1010B | 6 | 6 | 156 ± 0.5 | 6 | 73 ± 0.3 | | | | M5 |
| MR-J4W3-222B/MR-J4W3-444B | 6 | 6 | 156 ± 0.5 | 6 | 73 ± 0.3 | | | | M5 |

APPENDIX

App. 4.9 Check list for user documentation



MR-J4 installation checklist for manufacturer/installer

The following items must be satisfied by the initial test operation at least. The manufacturer/installer must be responsible for checking the standards in the items.

Maintain and keep this checklist with related documents of machines to use this for periodic inspection.

1. Is it based on directive/standard applied to the machine? Yes [], No []
2. Is directive/standard contained in Declaration of Conformity (DoC)? Yes [], No []
3. Does the protection instrument conform to the category required? Yes [], No []
4. Are electric shock protective measures (protective class) effective? Yes [], No []
5. Is the STO function checked (test of all the shut-off wiring)? Yes [], No []

Checking the items will not be instead of the first test operation or periodic inspection by professional engineers.

APPENDIX

App. 5 MR-J3-D05 Safety logic unit

App. 5.1 Contents of the package

Open packing, and confirm the content of packing.

| Contents | Quantity |
|--------------------------------------------------|----------|
| MR-J3-D05 Safety logic unit | 1 |
| Connector for CN9 1-1871940-4 (TE Connectivity) | 1 |
| Connector for CN10 1-1871940-8 (TE Connectivity) | 1 |
| MR-J3-D05 Safety Logic Unit Installation Guide | 1 |

App. 5.2 Terms related to safety

App. 5.2.1 Stop function for IEC/EN 61800-5-2

(1) STO function (Refer to IEC/EN 61800-5-2: 2007 4.2.2.2 STO.)

This function is integrated into the MR-J4 series servo amplifiers.

The STO function shuts down energy to servo motors, thus removing torque. This function electronically cuts off power supply in servo amplifiers for MR-J4 series servo amplifiers.

The purpose of this function is as follows.

- 1) Uncontrolled stop according to stop category 0 of IEC/EN 60204-1
- 2) Preventing unexpected start-up

(2) SS1 function (Refer to IEC/EN 61800-5-2: 2007 4.2.2.3C Safe stop 1 temporal delay.)

SS1 is a function which initiates the STO function when the previously set delay time has passed after the servo motor starts decelerating. The delay time can be set with MR-J3-D05.

The purpose of this function is as follows. This function is available by using an MR-J4 series servo amplifier with MR-J3-D05.

- Controlled stop according to stop category 1 of IEC/EN 60204-1

App. 5.2.2 Emergency operation for IEC/EN 60204-1

(1) Emergency stop (Refer to IEC/EN 60204-1: 2005 9.2.5.4.2 Emergency Stop.)

Emergency stop must override all other functions and actuation in all operation modes. Power to the machine driving part which may cause a hazardous state must be either removed immediately (stop category 0) or must be controlled to stop such hazardous state as soon as possible (stop category 1). Restart must not be allowed even after the cause of the emergency state has been removed.

(2) Emergency switching off (Refer to IEC/EN 60204-1: 2005 9.2.5.4.3 Emergency Switching OFF.)

Removal of input power to driving device to remove electrical risk and to meet above mentioned safety standards.

APPENDIX

App. 5.3 Cautions

The following basic safety notes must be read carefully and fully in order to prevent injury to persons or damage to property.

Only qualified personnel are authorized to install, start-up, repair or service the machines in which these components are installed.

They must be familiar with all applicable local safety regulations and laws in which machines with these components are installed, particularly the standards and guidelines mentioned in this Instruction Manual and the requirements mentioned in ISO/EN ISO 13849-1, IEC 61508, IEC/EN 61800-5-2, and IEC/EN 60204-1.

The staff responsible for this work must be given express permission from the company to perform start-up, programming, configuration, and maintenance of the machine in accordance with the safety standards.

| | | |
|-----------------------------------------------------------------------------------|----------------|-----------------------------------------------------------------------------------------------------------------------------------------------------------------------------------|
|  | WARNING | ● Improper installation of the safety related components or systems may cause improper operation in which safety is not assured, and may result in severe injuries or even death. |
|-----------------------------------------------------------------------------------|----------------|-----------------------------------------------------------------------------------------------------------------------------------------------------------------------------------|

Protective Measures

- As described in IEC/EN 61800-5-2, the Safe Torque Off (STO) function only prevents the MFR-J4 series servo amplifier from supplying energy to the servo motor. Therefore, if an external force acts upon the drive axis, additional safety measures, such as brakes or counter-weights must be used.

App. 5.4 Residual risk

Machine manufacturers are responsible for all risk evaluations and all associated residual risks. Below are residual risks associated with the STO/EMG function. Mitsubishi Electric is not liable for any damages or injuries caused by the residual risks.

- (1) The SS1 function only guarantees the delay time before STO/EMG is engaged. Proper setting of this delay time is the full responsibility of the company and/or individuals responsible for installation and commissioning of the safety related system. The system, as a whole, must pass safety standards certification.
- (2) When the SS1 delay time is shorter than the required servo motor deceleration time, if the forced stop function is malfunctioning, or if STO/EMG is engaged while the servo motor is still rotating; the servo motor will stop with the dynamic brake or freewheeling.
- (3) For proper installation, wiring, and adjustment, thoroughly read the manual of each individual safety related component.
- (4) Be sure that all safety related switches, relays, sensors, etc., meet the required safety standards. The Mitsubishi Electric safety related components mentioned in this manual are certified by Certification Body as meeting the requirements of ISO/EN ISO 13849-1 Category 3, PL d and IEC 61508 SIL 2.
- (5) Safety is not assured until safety-related components of the system are completely installed or adjusted.
- (6) When replacing a servo amplifier etc. or MR-J3-D05, confirm that the new equipment is exactly the same as those being replaced. Once installed, be sure to verify the performance of the functions before commissioning the system.

APPENDIX

- (7) Perform all risk assessments and safety level certification to the machine or the system as a whole. It is recommended that a Certification Body final safety certification of the system be used.
- (8) To prevent accumulation of multiple malfunctions, perform a malfunction check at regular intervals as deemed necessary by the applicable safety standard. Regardless of the system safety level, malfunction checks should be performed at least once per year.
- (9) If the upper and lower power modules in the servo amplifier are shorted and damaged simultaneously, the servo motor may make a half revolution at a maximum. For a linear servo motor, the primary side will move a distance of pole pitch.

App. 5.5 Block diagram and timing chart

(1) Function block diagram

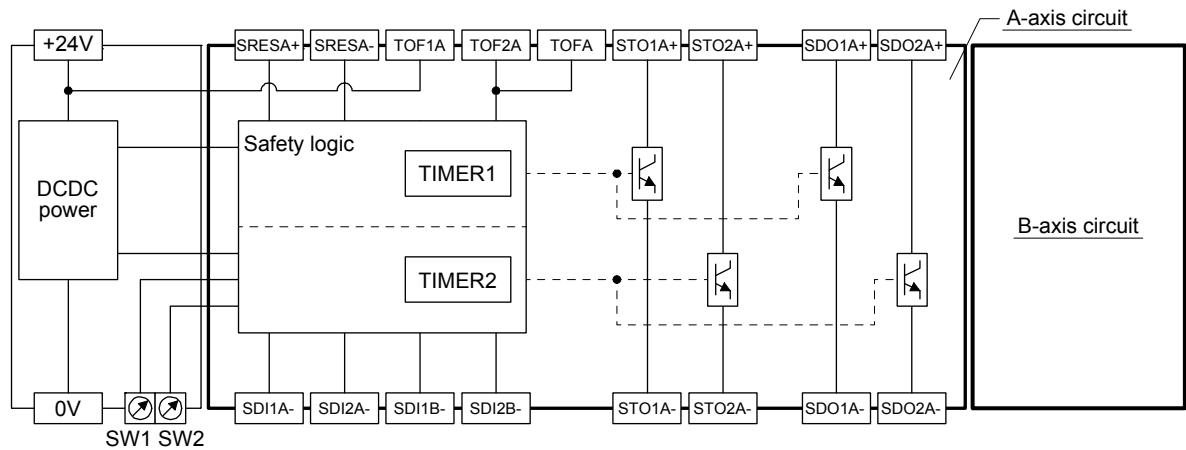

(2) Operation sequence

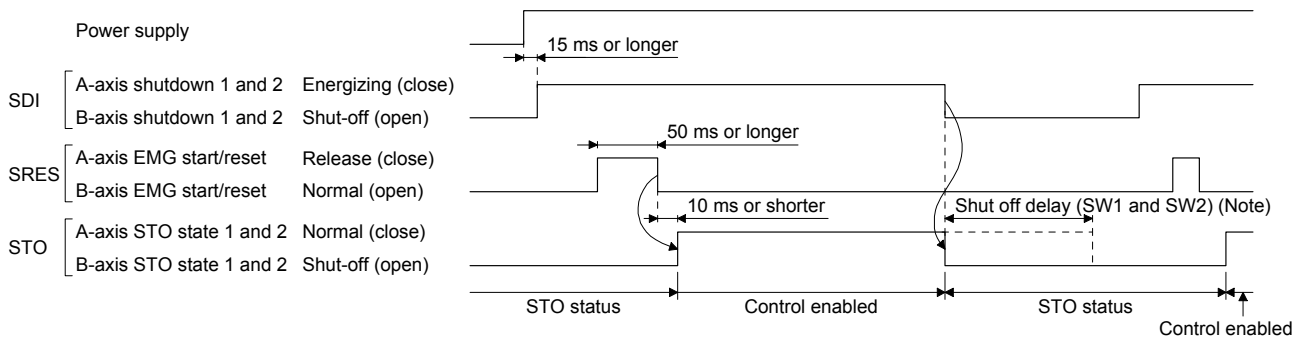

Note. Refer to App. 5.10.

App. 5.6 Maintenance and disposal

MR-J3-D05 safety logic unit is equipped with LED displays to check errors for maintenance. Please dispose this unit according to your local laws and regulations.

App. 5.7 Functions and configuration

App. 5.7.1 Summary

MR-J3-D05 has two systems in which the each system has SS1 function (delay time) and output of STO function.

APPENDIX

App. 5.7.2 Specifications

| Safety logic unit model | | MR-J3-D05 |
|----------------------------------|---------------------------------------------------------------|---------------------------------------------------------------------------------------------------------------------------------------------------|
| Control circuit power supply | Voltage | 24 V DC |
| | Permissible voltage fluctuation | 24 V DC \pm 10% |
| | Power supply capacity [A] | 0.5 (Note 1, 2) |
| Compatible system | | 2 systems (A-axis, B-axis independent) |
| Shut-off input | | 4 points (2 points \times 2 systems) SDI_: (source/sink compatible) (Note 3) |
| Shut-off release input | | 2 points (1 point \times 2 systems) SRES_: (source/sink compatible) (Note 3) |
| Feedback input | | 2 points (1 point \times 2 systems) TOF_: (source compatible) (Note 3) |
| Input type | | Photocoupler insulation, 24 V DC (external supply), internal limited resistance 5.4 k Ω |
| Shut-off output | | 8 points (4 point \times 2 systems) STO_: (source compatible) (Note 3) SDO_: (source/sink compatible) (Note 3) |
| Output method | | Photocoupler insulation, open-collector type Permissible current: 40 mA/1 output, Inrush current: 100 mA/1 output |
| Delay time setting | | A-axis: Select from 0 s, 1.4 s, 2.8 s, 5.6 s, 9.8 s, or 30.8 s. B-axis: Select from 0 s, 1.4 s, 2.8 s, 9.8 s, or 30.8 s. Accuracy: \pm 2% |
| Functional safety | | STO, SS1 (IEC/EN 61800-5-2) EMG STOP, EMG OFF IEC/EN 60204-1 |
| Safety performance | Standards certified by CB | EN ISO 13849-1 Category 3 PL d, IEC 61508 SIL 2, EN 62061 SIL CL 2, and EN 61800-5-2 SIL 2 |
| | Response performance (when delay time is set to 0 s) (Note 4) | 10 ms or less (STO input off \rightarrow shut-off output off) |
| | Mean time to dangerous failure (MTTFd) | 516 years |
| | Diagnosis converge (DC avg) | 93.1% |
| | Average probability of dangerous failures per hour (PFH) | 4.75×10^{-9} [1/h] |
| Compliance with global standards | CE marking | LVD: EN 61800-5-1 EMC: EN 61800-3 MD: EN ISO 13849-1, EN 61800-5-2, EN 62061 |
| Structure | | Natural-cooling, open (IP rating: IP 00) |
| Environment | Ambient temperature | 0 °C to 55 °C (non-freezing), storage: -20 °C to 65 °C (non-freezing) |
| | Ambient humidity | 5 %RH to 90 %RH (non-condensing), storage: 5 %RH to 90 %RH (non-condensing) |
| | Ambience | Indoors (no direct sunlight), free from corrosive gas, flammable gas, oil mist, dust, and dirt |
| | Altitude | Max. 1000 m above sea level |
| | Vibration resistance | 5.9 m/s ² at 10 Hz to 55 Hz (directions of X, Y, and Z axes) |
| Mass | [kg] | 0.2 (including CN9 and CN10 connectors) |

- Note 1. Inrush current of approximately 1.5 A flows instantaneously when turning the control circuit power supply on. Select an appropriate capacity of power supply considering the inrush current.
2. Power-on duration of the safety logic unit is 100,000 times.
3. _: in signal name indicates a number or axis name.
4. For the test pulse input, contact your local sales office.

APPENDIX

App. 5.7.3 When using MR-J3-D05 with an MR-J4 series servo amplifier

(1) System configuration diagram

| |
|-----------------------------------------------------------|
| POINT |
| ●MR-D05UDL_M (STO cable) for MR-J3 series cannot be used. |

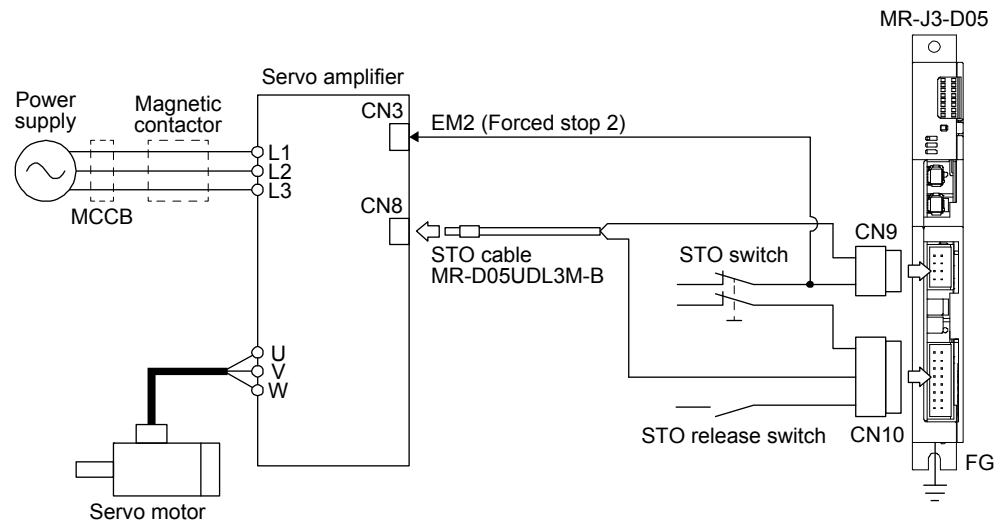

APPENDIX

(2) Connection example

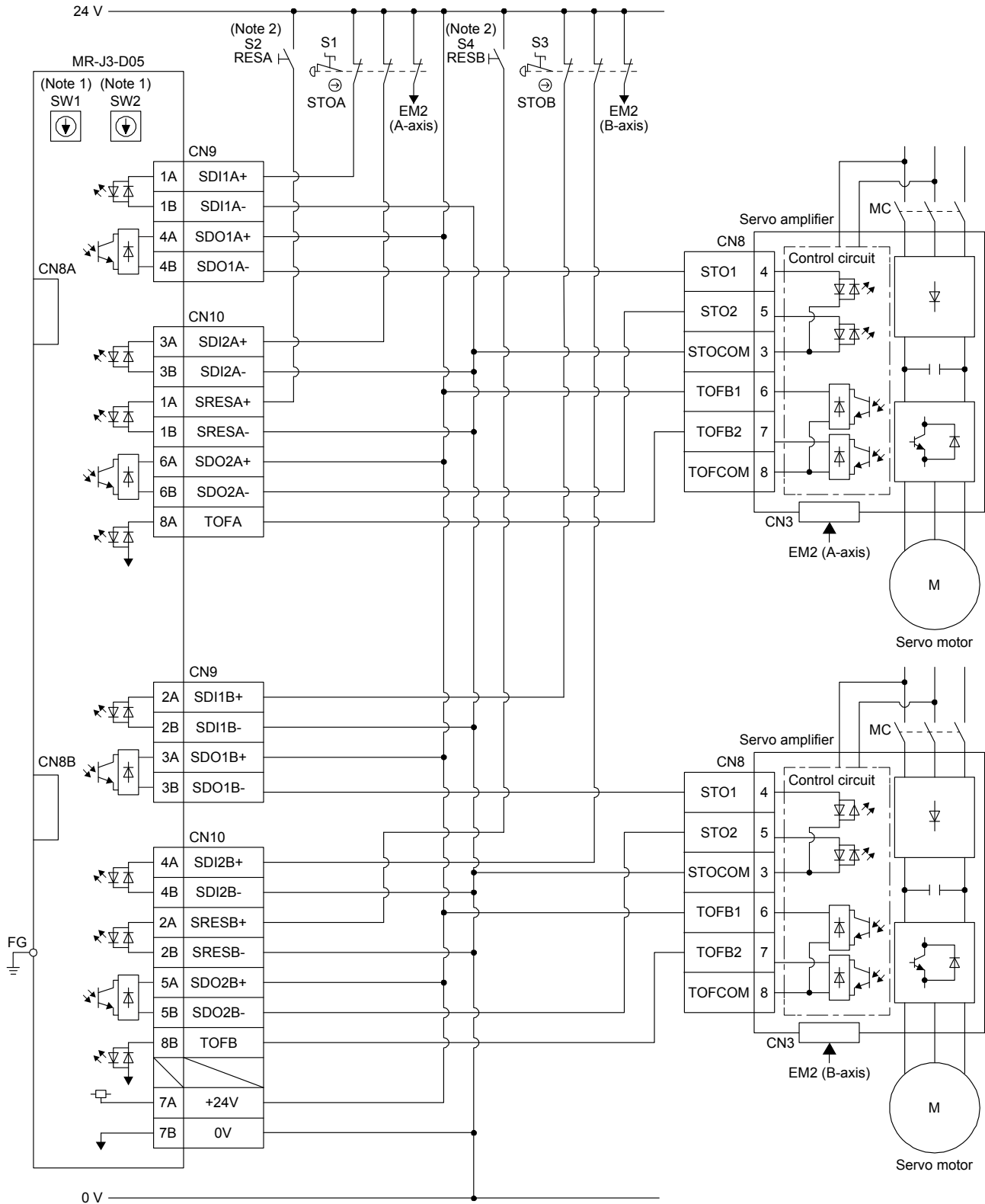

- Note 1. Set the delay time of STO output with SW1 and SW2. These switches are located where denoted from the front panel.
 Note 2. To release the STO state (base circuit shut-off), turn RESA and RESB on and turn them off.

APPENDIX

App. 5.8 Signal

App. 5.8.1 Connector/pin assignment

(1) CN8A

| Device | Symbol | Pin No. | Function/Application | I/O division |
|------------------|------------------|---------|------------------------------------------------------------------------------------------------------------------------------------------------------------------------------------|--------------|
| A-axis STO1 | STO1A- STO1A+ | 1 | Outputs STO1 to A-axis driving device. | O |
| | | 4 | Outputs the same signal as A-axis STO2. STO state (base shutdown): Between STO1A+ and STO1A- is opened. STO release state (in driving): Between STO1A+ and STO1A- is closed. | |
| A-axis STO2 | STO2A- STO2A+ | 5 | Outputs STO2 to A-axis driving device. | O |
| | | 6 | Outputs the same signal as A-axis STO1. STO state (base shutdown): Between STO2A+ and STO2A- is opened. STO release state (in driving): Between STO2A+ and STO2A- is closed. | |
| A-axis STO state | TOF2A TOF1A | 7 | Inputs STO state of A-axis driving device. | I |
| | | 8 | STO state (base shutdown): Open between TOF2A and TOF1A. STO release state (in driving): Close between TOF2A and TOF1A. | |

(2) CN8B

| Device | Symbol | Pin No. | Function/Application | I/O division |
|------------------|------------------|---------|------------------------------------------------------------------------------------------------------------------------------------------------------------------------------------|--------------|
| B-axis STO1 | STO1B- STO1B+ | 1 | Outputs STO1 to B-axis driving device. | O |
| | | 4 | Outputs the same signal as B-axis STO2. STO state (base shutdown): Between STO1B+ and STO1B- is opened. STO release state (in driving): Between STO1B+ and STO1B- is closed. | |
| B-axis STO2 | STO2B- STO2B+ | 5 | Outputs STO2 to B-axis driving device. | O |
| | | 6 | Outputs the same signal as B-axis STO1. STO state (base shutdown): Between STO2B+ and STO2B- is opened. STO release state (in driving): Between STO2B+ and STO2B- is closed. | |
| B-axis STO state | TOF2B TOF1B | 7 | Inputs STO state of B-axis driving device. | I |
| | | 8 | STO state (base shutdown): Open between TOF2B and TOF1B. STO release state (in driving): Close between TOF2B and TOF1B. | |

(3) CN9

| Device | Symbol | Pin No. | Function/Application | I/O division |
|-------------------|------------------|---------|------------------------------------------------------------------------------------------------------------------------------------------------------------------------------------|--------------|
| A-axis shutdown 1 | SDI1A+ SDI1A- | 1A | Connect this device to a safety switch for A-axis driving device. | DI-1 |
| | | 1B | Input the same signal as A-axis shutdown 2. STO state (base shutdown): Open between SDI1A+ and SDI1A-. STO release state (in driving): Close between SDI1A+ and SDI1A-. | |
| B-axis shutdown 1 | SDI1B+ SDI1B- | 2A | Connect this device to a safety switch for B-axis driving device. | DI-1 |
| | | 2B | Input the same signal as B-axis shutdown 2. STO state (base shutdown): Open between SDI1B+ and SDI1B-. STO release state (in driving): Close between SDI1B+ and SDI1B-. | |
| A-axis SDO1 | SDO1A+ SDO1A- | 4A | Outputs STO1 to A-axis driving device. | DO-1 |
| | | 4B | Outputs the same signal as A-axis SDO2. STO state (base shutdown): Between SDO1A+ and SDO1A- is opened. STO release state (in driving): Between SDO1A+ and SDO1A- is closed. | |
| B-axis SDO1 | SDO1B+ SDO1B- | 3A | Outputs STO1 to B-axis driving device. | DO-1 |
| | | 3B | Outputs the same signal as B-axis SDO2. STO state (base shutdown): Between SDO1B+ and SDO1B- is opened. STO release state (in driving): Between SDO1B+ and SDO1B- is closed. | |

APPENDIX

(4) CN10

| Device | Symbol | Pin No. | Function/Application | I/O division |
|------------------------------|------------------|----------|----------------------------------------------------------------------------------------------------------------------------------------------------------------------------------------------------------------------------------------------------|--------------|
| A-axis shutdown 2 | SDI2A+ SDI2A- | 3A 3B | Connect this device to a safety switch for A-axis driving device. Input the same signal as A-axis shutdown 1. STO state (base shutdown): Open between SDI2A+ and SDI2A-. STO release state (in driving): Close between SDI2A+ and SDI2A-. | DI-1 |
| B-axis shutdown 2 | SDI2B+ SDI2B- | 4A 4B | Connect this device to a safety switch for B-axis driving device. Input the same signal as B-axis shutdown 1. STO state (base shutdown): Open between SDI2B+ and SDI2B-. STO release state (in driving): Close between SDI2B+ and SDI2B-. | DI-1 |
| A-axis EMG start/reset | SRESA+ SRESA- | 1A 1B | Signal for releasing STO state (base shutdown) on A-axis driving device. Releases STO state (base shutdown) on A-axis driving device by switching between SRESA+ and SRESA- from on (connected) to off (opened). | DI-1 |
| B-axis EMG start/reset | SRESB+ SRESB- | 2A 2B | Signal for releasing STO state (base shutdown) on B-axis driving device. Releases STO state (base shutdown) on B-axis driving device by switching between SRESB+ and SRESB- from on (connected) to off (opened). | DI-1 |
| A-axis SDO2 | SDO2A+ SDO2A- | 6A 6B | Outputs STO2 to A-axis driving device. Outputs the same signal as A-axis STO1. STO state (base shutdown): Between SDO2A+ and SDO2A- is opened. STO release state (in driving): Between SDO2A+ and SDO2A- is closed. | DO-1 |
| B-axis SDO2 | SDO2B+ SDO2B- | 5A 5B | Outputs STO2 to B-axis driving device. Outputs the same signal as B-axis SDO1. STO state (base shutdown): Between SDO2B+ and SDO2B- is opened. STO release state (in driving): Between SDO2B+ and SDO2B- is closed. | DO-1 |
| Control circuit power supply | +24V | 7A | Connect + side of 24 V DC. | |
| Control circuit power GND | 0V | 7B | Connect - side of 24 V DC. | |
| A-axis STO state | TOFA | 8A | TOFA is internally connected with TOF2A. | |
| B-axis STO state | TOFB | 8B | TOFB is internally connected with TOF2B. | |

App. 5.8.2 Interfaces

In this servo amplifier, source type I/O interfaces can be used.

(1) Sink I/O interface (CN9, CN10 connector)

(a) Digital input interface DI-1

This is an input circuit whose photocoupler cathode side is the input terminal.

Transmit signals from sink (open-collector) type transistor output, relay switch, etc.

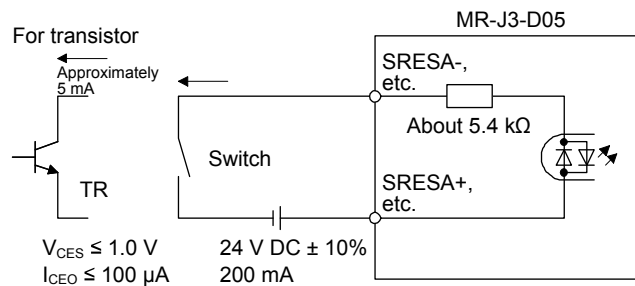

APPENDIX

(b) Digital output interface DO-1

This is a circuit in which the collector of the output transistor is the output terminal. When the output transistor is turned on, the current will flow to the collector terminal.

A lamp, relay or photocoupler can be driven. Install a diode (D) for an inductive load, or install an inrush current suppressing resistor (R) for a lamp load. (Rated current: 40 mA or less, maximum current: 50 mA or less, inrush current: 100 mA or less) A maximum of 2.6 V voltage drop occurs in the MR-J3-D05.

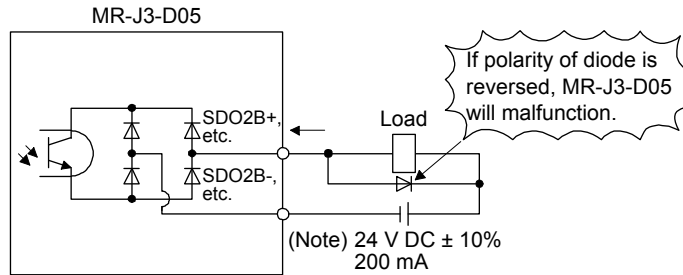

Note. If the voltage drop (maximum of 2.6 V) interferes with the relay operation, apply high voltage (maximum of 26.4 V) from external source.

(2) Source I/O interfaces (CN9, CN10 connector)

(a) Digital input interface DI-1

This is an input circuit whose photocoupler anode side is the input terminal.

Transmit signals from source (open-collector) type transistor output, relay switch, etc.

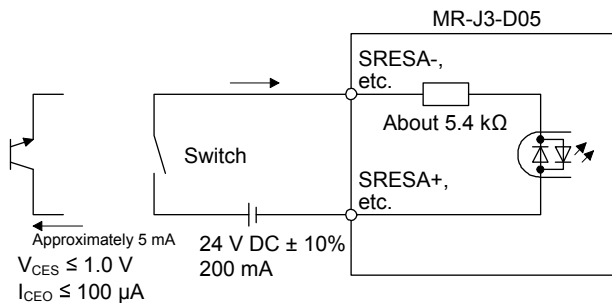

(b) Digital output interface DO-1

This is a circuit in which the emitter of the output transistor is the output terminal. When the output transistor is turned on, the current will flow from the output terminal to a load.

A maximum of 2.6 V voltage drop occurs in the MR-J3-D05.

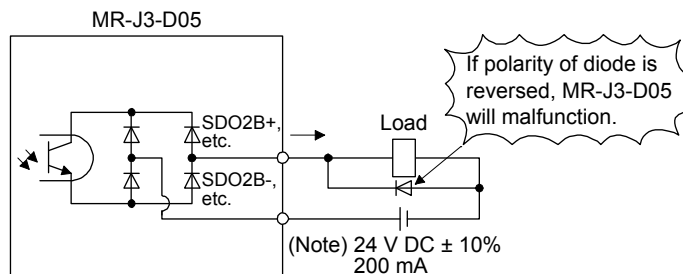

Note. If the voltage drop (maximum of 2.6 V) interferes with the relay operation, apply high voltage (maximum of 26.4 V) from external source.

APPENDIX

App. 5.8.3 Wiring CN9 and CN10 connectors

Handle with the tool with care when connecting wires.

(1) Wire strip

- (a) Use wires with size of AWG 24 to 20 (0.22 mm^2 to 0.5 mm^2) (recommended electric wire: UL 1007) and strip the wires to make the stripped length $7.0 \text{ mm} \pm 0.3 \text{ mm}$. Confirm the stripped length with gauge, etc. before using the wires.
- (b) If the stripped wires are bent, loose or too thick due to twisting too much, fix the wires by twisting lightly, etc. Then, confirm the stripped length before using the wires. Do not use excessively deformed wires.
- (c) Smooth out the wire surface and stripped insulator surface.

(2) Connecting wires

Before connecting wires, be sure to pull out the receptacle assembly from the header connector. If wires are connected with inserted connector, the connector and the printed board may malfunction.

(a) Using extraction tool (1891348-1 or 2040798-1)

1) Dimensions and mass

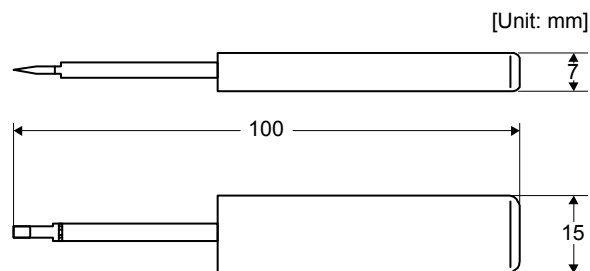

Mass: Approx. 20 g

APPENDIX

2) Connecting wires

- a) Confirm the model number of the housing, contact and tool to be used.
- b) Insert the tool diagonally into the receptacle assembly.

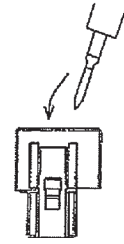

- c) Insert the tool until it hits the surface of the receptacle assembly. At this stage, the tool is vertical to the receptacle assembly.

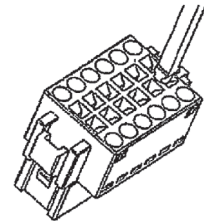

- d) Insert wires in the wiring hole till the end. The wires should be slightly twisted in advance to prevent it from being loose.

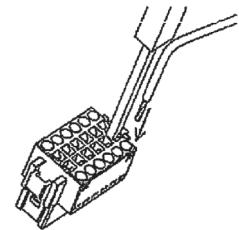

It is easy to insert the wire if the wire is inserted diagonally while twisting the tool.

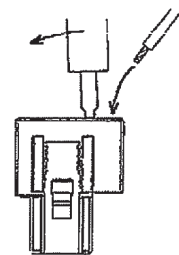

- e) Remove the tool.

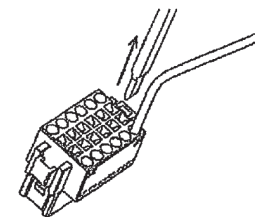

APPENDIX

(b) Using a screwdriver

To avoid damaging housings and springs when wiring with screwdriver, do not put excessive force. Be cautious when connecting.

1) Applicable screwdriver

Diameter: 2.3 mm \pm 0.05 mm
Length: 120 mm or less
Width: 2.3 mm, Blade thickness: 0.25 mm
Angle in tip of the blade: 18 ± 1 degrees

Diameter: 2.5 mm \pm 0.05 mm
Length: 120 mm or less
Width: 2.5 mm, Blade thickness: 0.3 mm
Angle in tip of the blade: 12 ± 1 degrees

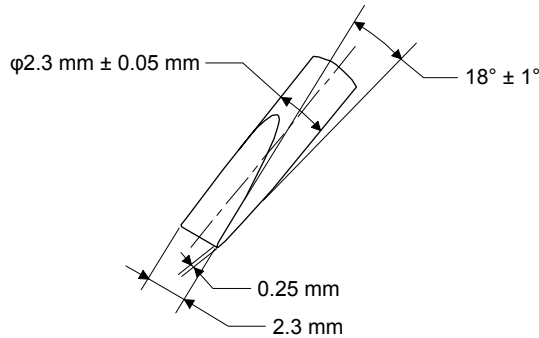

Screwdriver diameter: $\phi 2.3 \text{ mm}$

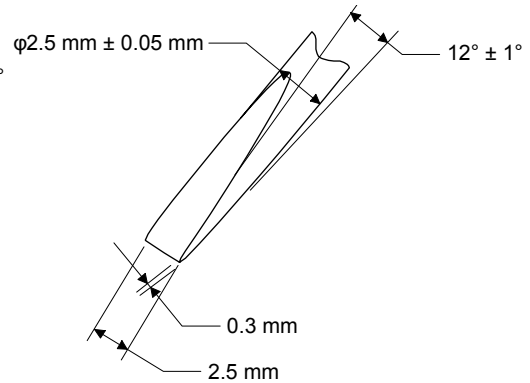

Screwdriver diameter: $\phi 2.5 \text{ mm}$

2) Connecting wires

- Insert a screwdriver in the front slot a little diagonally, and depress the spring. While depressing the spring, insert the wires until they hit the end. Note that the housing and spring may be damaged if the screwdriver is inserted strongly. Never insert the screwdriver in the wire hole. Otherwise, the connector will be damaged.
- Pull the screwdriver out while pressing the wires. Connecting wires is completed.
- Pull the wire lightly to confirm that the wire is surely connected.
- To remove the wires, depress the spring by the screwdriver in the same way as connecting wires, and then pull the wires out.

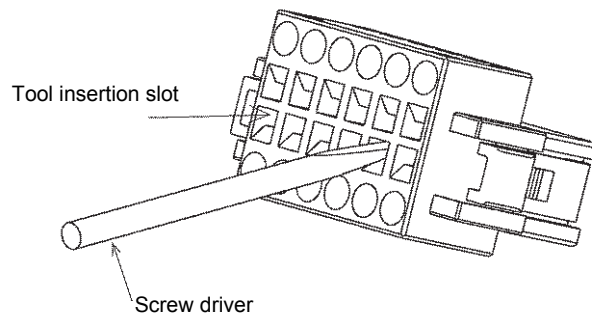

APPENDIX

(3) Connector insertion

Insert the connector all the way straight until you hear or feel clicking. When removing the connector, depress the lock part completely before pulling out. If the connector is pulled out without depressing the lock part completely, the housing, contact and/or wires may be damaged.

(4) Applicable wire

Applicable wire size is listed below.

| Wire size | |
|-----------------|-----|
| mm ² | AWG |
| 0.22 | 24 |
| 0.34 | 22 |
| 0.50 | 20 |

(5) Others

(a) Fix a cable tie keeping a distance of "A" × 1.5 or longer from the end of the connector.

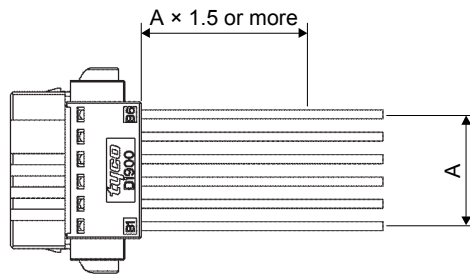

(b) Be sure that wires are not pulled excessively when the connector is inserted.

App. 5.8.4 Wiring FG

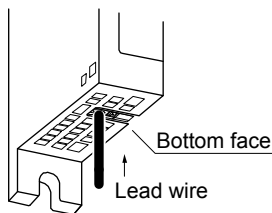

Wire range

Single wire: $\phi 0.4$ mm to 1.2 mm (AWG 26 to AWG 16)

Stranded wire: 0.2 mm² to 1.25 mm² (AWG 24 to AWG 16),
wire $\phi 0.18$ mm or more

APPENDIX

App. 5.9 LED display

I/O status, malfunction and power on/off are displayed with LED for each A-axis and B-axis.

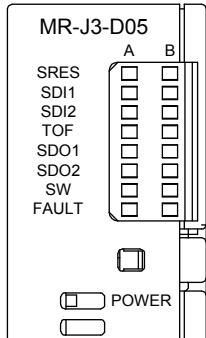

| LED | Definition | LED | |
|-------|-----------------------------------------------------------------------------------------------------------------------------------------------------------|----------|----------|
| | | Column A | Column B |
| SRES | Monitor LED for start/reset Off: The start/reset is off. (The switch contact is opened.) On: The start/reset is on. (The switch contact is closed.) | A-axis | B-axis |
| SDI1 | Monitor LED for shut-off 1 Off: The shut-off 1 is off. (The switch contact is closed.) On: The shut-off 1 is on. (The switch contact is opened.) | | |
| SDI2 | Monitor LED for shut-off 2 Off: The shut-off 2 is off. (The switch contact is closed.) On: The shut-off 2 is on. (The switch contact is opened.) | | |
| TOF | Monitor LED for STO state Off: Not in STO state On: In STO state | | |
| SDO1 | Monitor LED for SDO1 Off: Not in STO state On: In STO state | | |
| SDO2 | Monitor LED for SDO2 Off: Not in STO state On: In STO state | | |
| SW | Monitor LED for confirming shutdown delay setting Off: The settings of SW1 and SW2 do not match. On: The settings of SW1 and SW2 match. | | |
| FAULT | FAULT LED Off: Normal operation (STO monitoring state) On: Fault has occurred. | | |
| POWER | Power supply Off: Power is not supplied to MR-J3-D05. On: Power is being supplied to MR-J3-D05. | / | |

App. 5.10 Rotary switch setting

Rotary switch is used to shut off the power after control stop by SS1 function.

Set the delay time from when the STO shut off switch is pressed until when STO output is performed. Set the same setting for SW1 and SW2. The following table shows the delay time to be set according to the setting value of the rotary switch.

Setting cannot be changed while power is on. Notify users that setting cannot be changed by putting a seal or by another method so that end users will not change the setting after the shipment.

0 to F in the following table is the set value of the rotary switches (SW1 and SW2).

Rotary switch setting and delay time at A-axis/B-axis [s]

| | | B-axis | | | | | |
|--------|--------|--------|-------|-------|-------|-------|--------|
| | | 0 s | 1.4 s | 2.8 s | 5.6 s | 9.8 s | 30.8 s |
| A-axis | 0 s | 0 | 1 | 2 | - | 3 | 4 |
| | 1.4 s | - | - | 5 | - | 6 | 7 |
| | 2.8 s | - | - | 8 | - | 9 | A |
| | 5.6 s | - | - | - | - | B | C |
| | 9.8 s | - | - | - | - | D | E |
| | 30.8 s | - | - | - | - | - | F |

APPENDIX

App. 5.11 Troubleshooting

When power is not supplied or FAULT LED turns on, refer the following table and take the appropriate action.

| Event | Definition | Cause | Action |
|------------------------|-------------------------------------------------------------|----------------------------------------------------------------------------------------------------------|----------------------------------------------------|
| Power is not supplied. | Power LED does not turn on although power is supplied. | 1. 24 V DC power supply is malfunctioning. | Replace the 24 V DC power supply. |
| | | 2. Wires between MR-J3-D05 and 24 V DC power supply are disconnected or are in contact with other wires. | Check the wiring. |
| | | 3. MR-J3-D05 is malfunctioning. | Replace the MR-J3-D05. |
| FAULT LED is on. | FAULT LED of A-axis or B-axis is on, and will not turn off. | 1. The delay time settings are not matched. | Check the settings of the rotary switch. |
| | | 2. Switch input error | Check the wiring or sequence of the input signals. |
| | | 3. TOF signal error | Check the connection with the servo amplifier. |
| | | 4. MR-J3-D05 is malfunctioning. | Replace the MR-J3-D05. |

APPENDIX

App. 5.12 Dimensions

[Unit: mm]

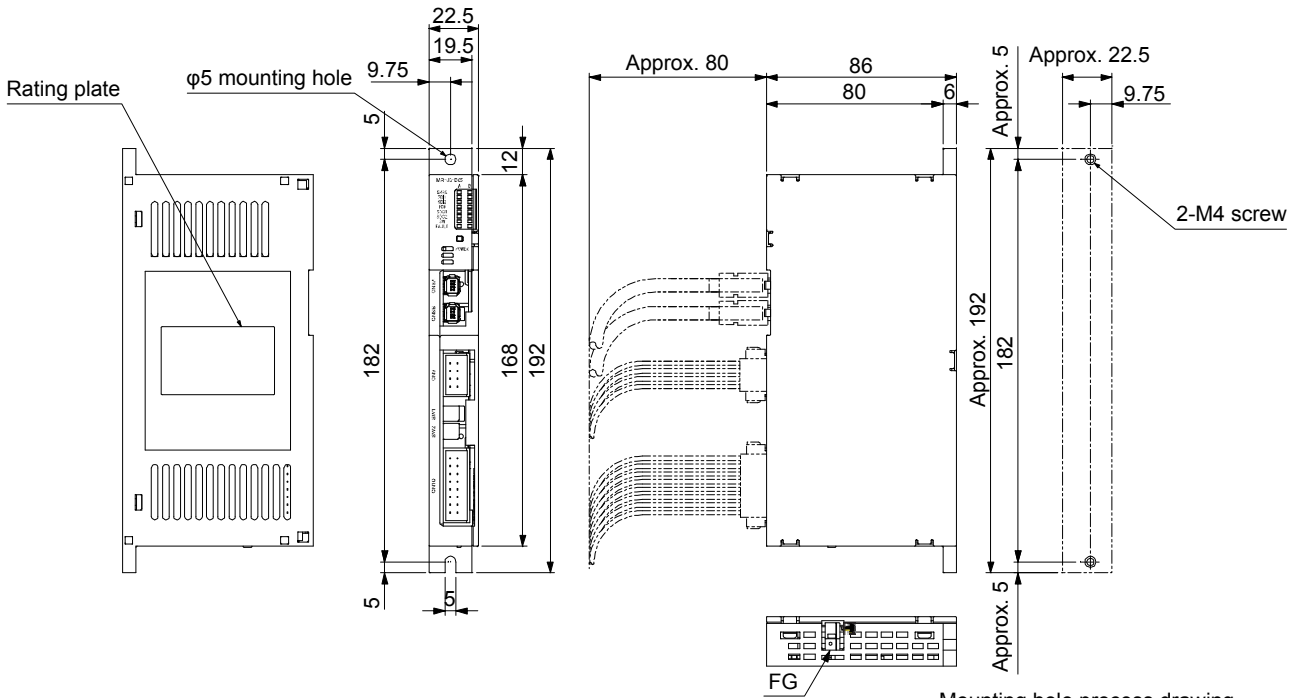

Mounting hole process drawing

Assignment

| CN8A | | CN8B | |
|--------|--------|--------|--------|
| 7 | 8 | 7 | 8 |
| TOF2A | TOF1A | TOF2B | TOF1B |
| 5 | 6 | 5 | 6 |
| STO2A- | STO2A+ | STO2B- | STO2B+ |
| 3 | 4 | 3 | 4 |
| | STO1A+ | | STO1B+ |
| 1 | 2 | 1 | 2 |
| STO1A- | | STO1B- | |

| CN9 | | CN10 | |
|--------|--------|--------|--------|
| 1A | 1B | 1A | 1B |
| SDI1A+ | SDI1A- | SRESA+ | SRESA- |
| 2A | 2B | 2A | 2B |
| SDI1B+ | SDI1B- | SRESB+ | SRESB- |
| 3A | 3B | 3A | 3B |
| SDO1B+ | SDO1B- | SDI2A+ | SDI2A- |
| 4A | 4B | 4A | 4B |
| SDO1A+ | SDO1A- | SDI2B+ | SDI2B- |
| | | 5A | 5B |
| | | SDO2B+ | SDO2B- |
| | | 6A | 6B |
| | | SDO2A+ | SDO2A- |
| | | 7A | 7B |
| | | +24 V | 0 V |
| | | 8A | 8B |
| | | TOFA | TOFB |

Mounting screw

Screw size: M4

Tightening torque: 1.2 N•m

Mass: 0.2 [kg]

APPENDIX

App. 5.13 Installation

Follow the instructions in this section and install MR-J3-D05 in the specified direction. Leave clearances between MR-J3-D05 and other equipment including the cabinet.

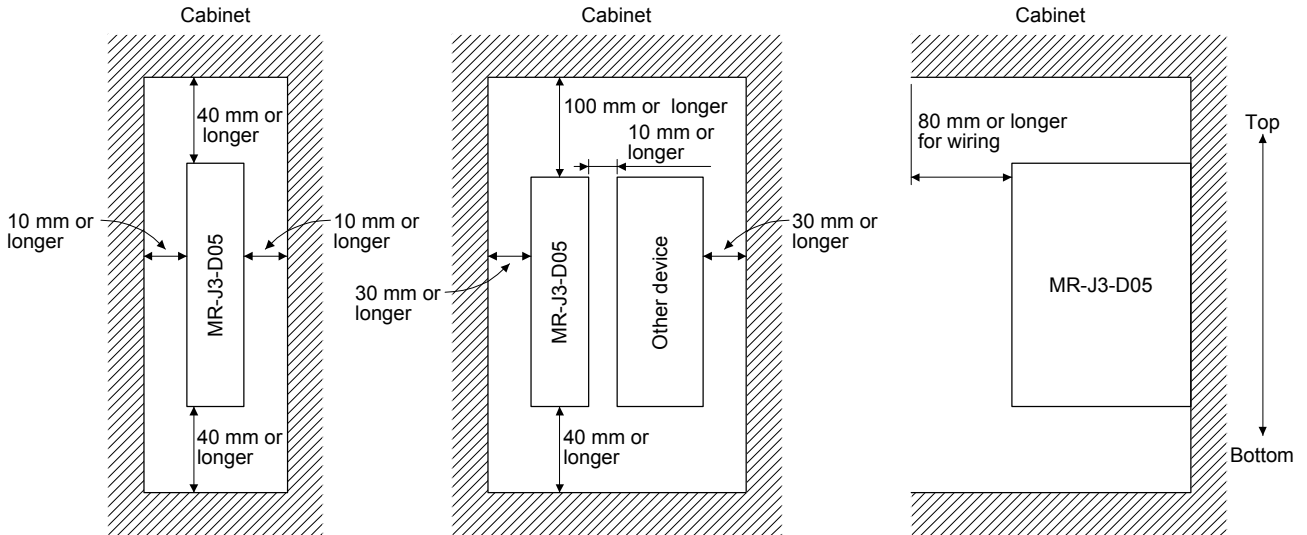

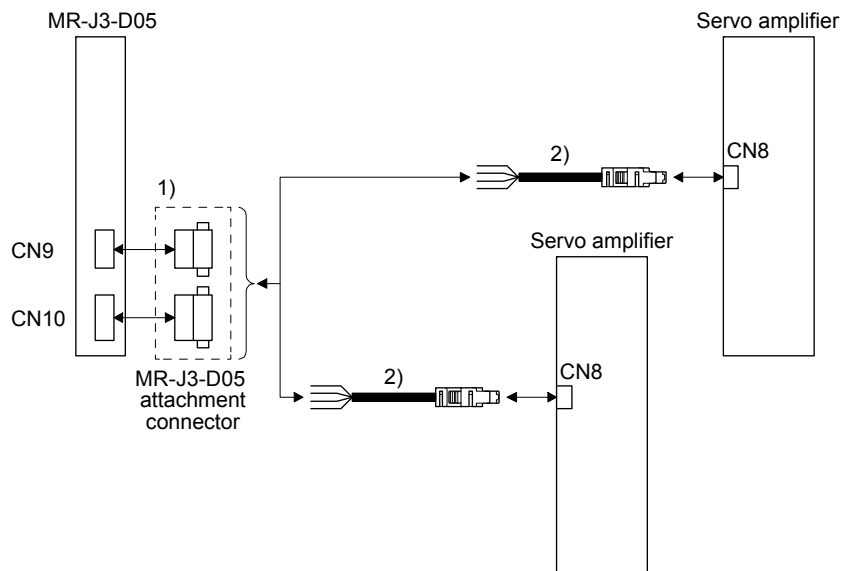

App. 5.14 Combinations of cable/connector

| |
|------------------------------------------------------------|
| POINT |
| ● MR-D05UDL_M (STO cable) for MR-J3 series cannot be used. |



APPENDIX

| No. | Name | Model | Description |
|-----|-----------|--------------------------------------|--------------------------------------------------------------------------------------------------------------------------------------------------------------------------------------------------------------------------------------------------------------------------------------------------------------------------------------------------------------------------------------------------------------------------------------------------------------------------|
| 1) | Connector | MR-J3-D05 attachment connector | <div style="display: flex; justify-content: space-around; align-items: center;"> <div style="text-align: center;">  <p>Connector for CN9: 1-1871940-4 (TE Connectivity)</p> </div> <div style="text-align: center;">  <p>Connector for CN10: 1-1871940-8 (TE Connectivity)</p> </div> </div> |
| 2) | STO cable | MR-D05UDL3M-B Cable length: 3 m | <p>Connector set: 2069250-1 (TE Connectivity)</p> <div style="text-align: center;">  </div> |

App. 6 EC declaration of conformity

The MR-J4 series servo amplifiers and MR-J3-D05 safety logic unit complies with the safety component laid down in the Machinery directive.

ZERTIFIKAT ◆ CERTIFICATE ◆ 認証証書 ◆ CERTIFICADO ◆ CERTIFICAT



Product Service

CERTIFICATE

No. Z10 16 08 66509 026

Holder of Certificate: **MITSUBISHI ELECTRIC CORPORATION**
Nagoya Works
 5-1-14, Yada-Minami
 Higashi-ku, Nagoya-shi
 Aichi
 461-8670 JAPAN

Factory(ies): 66509, 83304

Certification Mark:



Product: **AC servo systems**

Model(s): **Drive Unit MR-J4 Series**
Drive Unit MR-JE Series
For nomenclature see attachment

Parameters:

| | |
|---------------------------------|----------------------------|
| Safety function (EN 61800-5-2): | STO |
| Ambient temperature: | |
| Operation: | 0°C to 55°C |
| Storage: | -20°C to 65°C |
| Altitude: | max. 2000m above sea level |

Tested according to:

EN ISO 13849-1:2015 (Cat 3, PL e)
 EN 62061:2005/A2:2015 (SILCL 3)
 IEC 62061(ed.1);am1;am2
 IEC 61508-1(ed.2) (SIL 3)
 IEC 61508-2(ed.2) (SIL 3)
 IEC 61508-4(ed.2) (SIL 3)
 EN 61800-5-1:2007
 IEC 61800-5-1(ed.2)
 EN 61800-5-2:2007
 IEC 61800-5-2(ed.2)
 IEC 61326-3-1(ed.1)

The product was tested on a voluntary basis and complies with the essential requirements. The certification mark shown above can be affixed on the product. It is not permitted to alter the certification mark in any way. In addition the certification holder must not transfer the certificate to third parties. See also notes overleaf.

Test report no.: MN86533T

Valid until: 2021-08-24



(Günter Greil)



Date, 2016-08-25

Page 1 of 3

TÜV SÜD Product Service GmbH · Zertifizierstelle · Ridlerstraße 65 · 80339 München · Germany

TÜV®

This certificate is valid until 2017-02-28. After March 2017, use the certificate shown on the previous page.



ZERTIFIKAT
CERTIFICATE

EC Type-Examination Certificate

Reg.-No.: 01/205/5196/12

| | | | |
|---------------------------------------------------------------------------------------------------------------------------------------------|-------------------------------------------------------------------------------------------------------------------------------------------------------------------------------------------------------------------------------------------------------------------------------------------|---------------------------|-----------------------------------------------------------------------------------------------------------------|
| Product tested | AC Servo Drive with integrated safety function "Safe Torque Off (STO)" | Certificate holder | Mitsubishi Electric Corporation Nagoya Works 1-14 Yada-Minami 5-chome Higashi-ku Nagoya 461-8670 Japan |
| Type designation | MR-J4-*A* MR-J4-*B* MR-J4W2-*B* MR-J4W3-*B* | Manufacturer | see certificate holder |
| Codes and standards forming the basis of testing | EN 61800-5-2:2007 EN 61800-5-1:2007 (in extracts) EN 61800-3:2004 EN ISO 13849-1:2008 + AC:2009 | | EN 62061:2005 + AC:2010 EN 60204-1:2006 + A1:2009 + AC:2010 (in extracts) IEC 61508 Parts 1-7:2010 |
| Intended application | The safety function "Safe Torque Off" complies with the requirements of the relevant standards (PL d acc. to EN ISO 13849-1, SIL CL 2 acc. to EN 61800-5-2/ EN 62061/ IEC 61508) and can be used in applications up to PL d acc. to EN ISO 13849-1 and SIL 2 acc. to EN 62061/ IEC 61508. | | |
| Specific requirements | The instructions of the associated Installation and Operating Manual shall be considered. | | |
| It is confirmed, that the product under test complies with the requirements for machines defined in Annex I of the EC Directive 2006/42/EC. | | | |
| This certificate is valid until 2017-02-28. | | | |



The test report-no.: 968/M 342.00/12 dated 2012-02-28 is an integral part of this certificate.

The holder of a valid licence certificate for the product tested is authorized to affix the test mark shown opposite to products, which are identical with the product tested.



Berlin, 2012-02-28

Certification Body for Machinery, NB 0035

Dipl.-Ing. Eberhard Frejno



ZERTIFIKAT
CERTIFICATE

Nr./No. 968/EL 612.00/09

| | | | |
|---------------------------------------------------------------------------|----------------------------------------------------------------------------------------------------------------------------------------------------------------------------------------------------------------------------------------------------------------------------------------------------------------------------------------------------------------------------------------------------------------------------------------|-----------------------------------------------------------------------------------|-----------------------------------------------------------------------------------------------------------------------------------------|
| Prüfgegenstand Product tested | Safety Logic Module for usage in combination with MR-J3-□S Servo Drives | Inhaber Holder | Mitsubishi Electric Corporation Nagoya Works 1-14 Yada-Minami 5-chome, Higashi-ku Nagoya 461-8670 Japan |
| Typbezeichnung Type designation | MR-J3-D05 | Verwendungszweck Intended application | Drive Applications STO / SS1 acc. to EN 61800-5-2 Safe Stop / Safe Off Stop Category 0 / Stop Category 1 acc. to EN 60204-1 |
| Prüfgrundlagen Codes and standards forming the basis of testing | EN ISO 13849-1:2008 EN 62061:2005 EN 61800-5-2:2007 EN 61800-5-1:2007 | EN 61800-3:2004 EN 60204-1:2006 EN 50178:1997 EN 61508-1 to -7:2000-2002 | |
| Prüfungsergebnis Test results | The MR-J3-D05 Safety Logic Module in combination with the MR-J3 series servo drives is suitable for the basic safety functions "STO" and "SS1" (Type C) according to EN 61800-5-2 as well as "Safe Stop" (Stop category 0 and Stop category 1) and "Safe Off" according to EN 60204-1. It can be used within safety related applications up to Safety Category 3 / PL d and SIL 2 / SIL CL 2 according to EN ISO 13849-1 and EN 62061. | | |
| Besondere Bedingungen Specific requirements | For a safe usage of the product the instructions in the user documentation must be observed. For "Safe Off" two suitable additional magnetic contactors must be used additionally. | | |

Der Prüfbericht-Nr.: 968/EL 612.00/09 vom 21.04.2009 ist Bestandteil dieses Zertifikates.
Dieses Zertifikat ist nur gültig für Erzeugnisse, die mit dem Prüfgegenstand übereinstimmen. Es wird ungültig bei jeglicher Änderung der Prüfgrundlagen für den angegebenen Verwendungszweck.

The test report-no.: 968/EL 612.00/09 dated 2009-04-21 is an integral part of this certificate.
This certificate is valid only for products which are identical with the product tested. It becomes invalid at any change of the codes and standards forming the basis of testing for the intended application.

TÜV Rheinland Industrie Service GmbH
Geschäftsfeld ASI
Automation, Software und Informationstechnologie
Am Grauen Stein, 51105 Köln
Postfach 91 09 51, 51101 Köln

2009-04-21
Datum/Date

Firmenstempel/Company stamp

Dipl.-Ing. Heinz Gall

App. 7 How to replace servo amplifier without magnetic pole detection



CAUTION

● Be sure to write the magnetic pole information of the servo amplifier before the replacement to the servo amplifier after the replacement. If the information before and after replacement are different, the servo motor may operate unexpectedly.

When replacing the servo amplifier, carry out the magnetic pole detection again. If the magnetic pole detection cannot be performed unavoidably, write the magnetic pole information from the servo amplifier before the replacement to the one after the replacement using MR Configurator2.

(1) Procedures

- (a) Read the magnetic pole information of the servo amplifier before the replacement.
- (b) Write the read magnetic pole information to the servo amplifier after the replacement.
- (c) Perform the test operation with the torque limit for ensuring the safety, and confirm that there is no trouble.

(2) Migration method of the magnetic pole information

(a) How to read the magnetic pole information from the servo amplifier before the replacement

- 1) Open the project in MR Configurator2, select "MR-J4-B" for model, and select "Linear" for operation mode. Tick the "Multi axis" box and select one from A-axis to C-axis from the menu.
- 2) Check that the personal computer is connected with the servo amplifier, and select "Diagnosis" and then "Linear diagnosis".
- 3) Click the "Magnetic pole information" button (1) in figure) to open the magnetic pole information window.
- 4) Click "Read All" of the magnetic pole information window. (2) in figure)
- 5) Confirm the data 1 and data 2 (3) in figure) of the magnetic pole information window and take notes.

(b) How to write the magnetic pole information to the servo amplifier after the replacement

- 1) Open the project in MR Configurator2, select "MR-J4-B" for model, and select "Linear" for operation mode. Tick the "Multi axis" box and select one from A-axis to C-axis from the menu.
- 2) Check that the personal computer is connected with the servo amplifier, and select "Diagnosis" and then "Linear diagnosis".
- 3) Click the "Magnetic pole information" button (1) in Figure) to open the magnetic pole information window.
- 4) Input the value of the magnetic pole information taken notes to the data 1 and data 2 (3) in figure) of the magnetic pole information window.
- 5) Click "Write All" (4) in figure) of the magnetic pole information window.

6) Cycle the power of the servo amplifier.

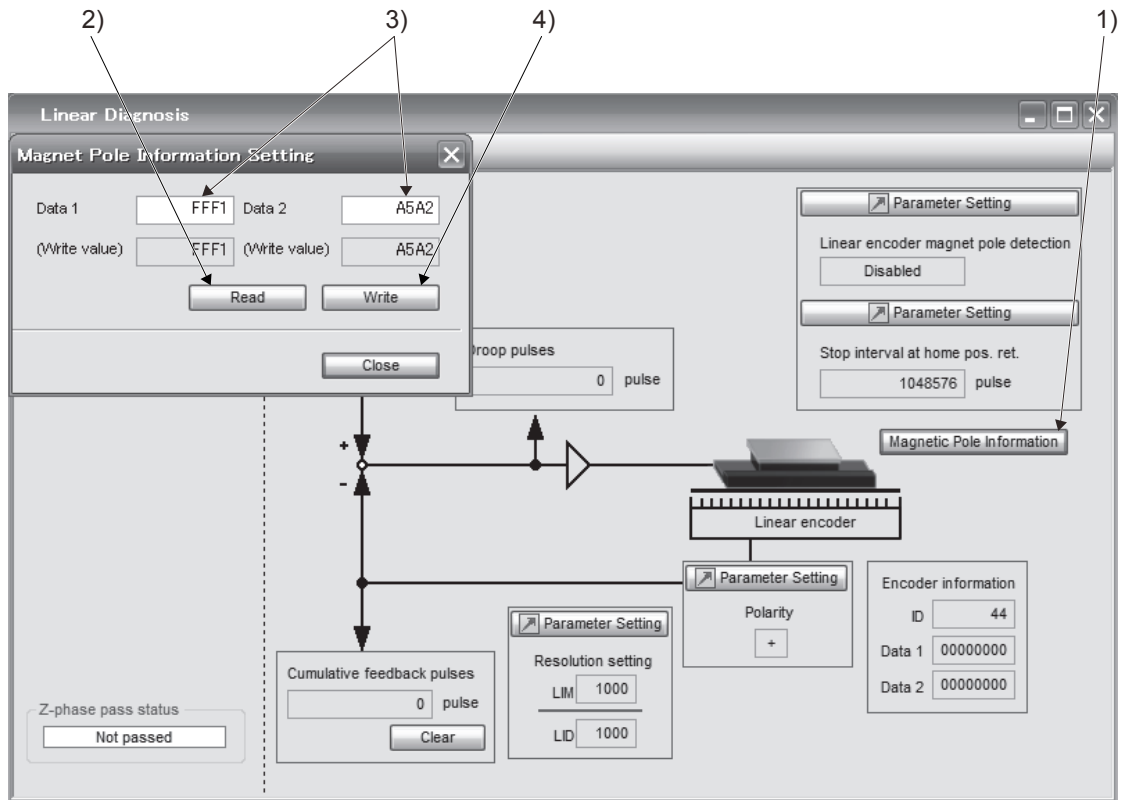

App. 8 Two-wire type encoder cable for HG-MR/HG-KR

Use a two-wire type encoder cable for the fully closed loop control of the MR-J4W2-_B servo amplifiers. For MR-EKCBL_M-_ encoder cables for HG-MR and HG-KR, up to 20 m cables are two-wire type. Therefore, when you need a longer encoder cable of two-wire type than 20 m, fabricate one using MR-ECNM connector set. Use the internal wiring diagram in the section to fabricate a cable up to 50 m.

App. 8.1 Configuration diagram

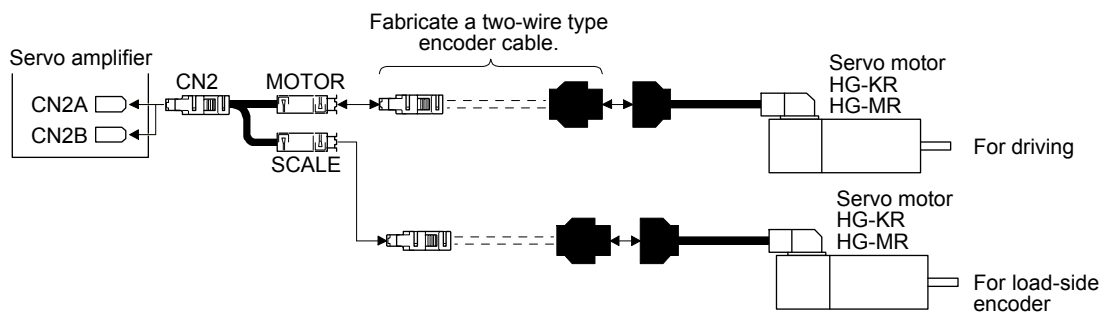

APPENDIX

App. 8.2 Connector set

| Connector set | 1) Servo amplifier-side connector | 2) Servo motor-side connector |
|---------------|----------------------------------------------------------------------------------------------------------------------------------------------------------------------------------------------|-----------------------------------------------------------------------------------------------------------------------------------------|
| MR-ECNM | Receptacle: 36210-0100PL Shell kit: 36310-3200-008 (3M) | Connector set: 54599-1019 (Molex) |
| | <p>View seen from wiring side. (Note)</p> | Housing: 1-172161-9 Connector pin: 170359-1 (TE Connectivity or equivalent) Cable clamp: MTI-0002 (Toa Electric Industrial) |
| | <p>Note. Keep open the pins shown with . Especially, pin 10 is provided for manufacturer adjustment. If it is connected with any other pin, the servo amplifier cannot operate normally.</p> | <p>View seen from wiring side.</p> |

App. 8.3 Internal wiring diagram

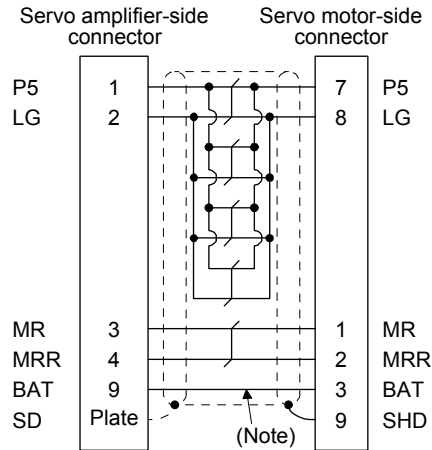

Note. Always make connection for use in an absolute position detection system. Wiring is not necessary for use in an incremental system.

APPENDIX

App. 9 SSCNET III cable (SC-J3BUS_M-C) manufactured by Mitsubishi Electric System & Service

| POINT |
|-------------------------------------------------------------------------------------------------------------------------------------------------------------------------------------------------------------------------------------------------------------------------------------------------------------------------|
| <ul style="list-style-type: none"> ● For the details of the SSCNET III cables, contact your local sales office. ● Do not look directly at the light generated from CN1A/CN1B connector of servo amplifier or the end of SSCNET III cable. The light can be a discomfort when it enters the eye. |

The cable is available per 1 m up to 100 m. The number of the length (1 to 100) will be in the underscore in the cable model.

| Cable model | Cable length | Bending life | Application/remark |
|--------------|--------------|-------------------------|---------------------------|
| | 1 m to 100 m | | |
| SC-J3BUS_M-C | 1 to 100 | Ultra-long bending life | Using long distance cable |

App. 10 CNP_crimping connector

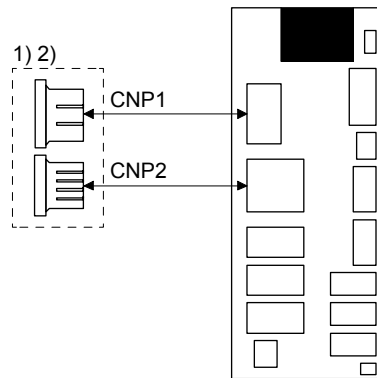

| No. | Name | Model | Definition | Number of parts | | |
|--------------------------------------------------------------------------------------------------------------------------------------------------------------------------------------------------------------------------------------------------------------------------------------|---------------------------------------------------------------------------------------------------------------------------------------------------------------------------------------------------------------------------------------------------------------------------------------|--------------------|---------------------------------------------------------------------------------------------------------------------------------------------------------------------------------------------------------------------------------------------------------------------------------------------------------------------------------------------------------------------------------------------------------------------------------------------------------------------------------------------------------------------------------------------------------------------------------------------------------------------------------------------------------------------------------------------------------------------------------------------------------------------------------------------------------------------------------------------------------------------------------------------------------------------------------------------------------------------------------------------------------------------------------------------------------------------------------------------------------------------------------------------------------------------------------------------------------------------------------------------------------------------------------|--------------------------------------------------------------------------------------------------------------------------------------------------------------------------------------------------------------------------------------------------------------------------------------|---------------------------------------------------------------------------------------------------------------------------------------------------------------------------------------------------------------------------------------------------------------------------------------|---------|
| 1) | Connector set | MR-J3WCNP12-DM | | 1 each | | |
| 2) | Connector set | MR-J3WCNP12-DM-10P | <table style="width: 100%; border: none;"> <tr> <td style="width: 50%; vertical-align: top;"> For CNP1 Receptacle housing: J43FSS-03V-KX Receptacle contact: BJ4F-71GF-M3.0 (JST) Applicable wire Wire size: 1.25 mm² to 2.0 mm² (AWG 16 to 14) Insulator OD: 2.0 mm to 3.8 mm The crimping tool (YRF-1130) is required. </td> <td style="width: 50%; vertical-align: top;"> For CNP2 Receptacle housing: F32FMS-06V-KXY Receptacle contact: BF3F-71GF-P2.0 (JST) Applicable wire Wire size: 1.25 mm² to 2.0 mm² (AWG 16 to 14) Insulator OD: 2.4 mm to 3.4 mm The crimping tool (YRF-1070) is required. </td> </tr> </table> | For CNP1 Receptacle housing: J43FSS-03V-KX Receptacle contact: BJ4F-71GF-M3.0 (JST) Applicable wire Wire size: 1.25 mm ² to 2.0 mm ² (AWG 16 to 14) Insulator OD: 2.0 mm to 3.8 mm The crimping tool (YRF-1130) is required. | For CNP2 Receptacle housing: F32FMS-06V-KXY Receptacle contact: BF3F-71GF-P2.0 (JST) Applicable wire Wire size: 1.25 mm ² to 2.0 mm ² (AWG 16 to 14) Insulator OD: 2.4 mm to 3.4 mm The crimping tool (YRF-1070) is required. | 10 each |
| For CNP1 Receptacle housing: J43FSS-03V-KX Receptacle contact: BJ4F-71GF-M3.0 (JST) Applicable wire Wire size: 1.25 mm ² to 2.0 mm ² (AWG 16 to 14) Insulator OD: 2.0 mm to 3.8 mm The crimping tool (YRF-1130) is required. | For CNP2 Receptacle housing: F32FMS-06V-KXY Receptacle contact: BF3F-71GF-P2.0 (JST) Applicable wire Wire size: 1.25 mm ² to 2.0 mm ² (AWG 16 to 14) Insulator OD: 2.4 mm to 3.4 mm The crimping tool (YRF-1070) is required. | | | | | |

APPENDIX

App. 11 Recommended cable for servo amplifier power supply

The following information is as of September 2015. For the latest information, contact the manufacturer.

Manufacturer: Mitsubishi Electric System & Service

<Sales office> FA PRODUCT DIVISION mail: oss-ip@melsc.jp

(1) Specifications

1 Primary-side power cable

| Name | Model | Wire size | Insulator material | Minimum bend radius [mm] | Insulator OD [mm] | Applicable standard (wire part) |
|-----------------------------------------------------------|------------------|-----------------|------------------------|--------------------------|-------------------|---------------------------------|
| 1) Main circuit power supply | SC-EMP01CBL_M-L | AWG 14 × 3 pcs. | PVC (red, white, blue) | 30 | Approx. 3.6 | UL 1063/MTW |
| 2) Control circuit power supply | SC-ECP01CBL_M-L | AWG 16 × 2 pcs. | PVC (red, white) | 30 | Approx. 3.2 | |
| 3) Regenerative option | SC-ERG01CBL_M-L | AWG 14 × 2 pcs. | PVC (black) | 30 | Approx. 3.6 | |
| 4) Built-in regenerative resistor short circuit connector | SC-ERG02CBL01M-L | AWG 14 × 1 pcs. | | - | | |

A symbol "_" in the model name indicates a cable length.

Motor-side power cable

| Name | Model | Wire size | Material | | Minimum bend radius [mm] | Overall diameter [mm] | Applicable standard (wire part) |
|----------------------------------------------------------------------------------------|-----------------------------------|-------------|-----------|--------------|--------------------------|-----------------------|---------------------------------|
| | | | Insulator | Outer sheath | | | |
| 5) Direct connection to rotary servo (up to 10 m) | Standard SC-EPWS1CBL_M-*-L | AWG 18 × 4C | ETFE | | 50 | Approx. 6.2 | UL 13/CL3 |
| 6) Long bending life | SC-EPWS1CBL_M-*-H | AWG 19 × 4C | | | 40 | Approx. 5.7 | UL AWM 2103 |
| 7) Linear servo (up to 10 m) | Standard SC-EPWS2CBL_M-L | AWG 18 × 4C | PVC | PVBC (black) | 50 | Approx. 6.2 | UL 13/CL3 |
| 8) Linear servo (more than 10 m)/junction connection to rotary servo (more than 10 m) | | AWG 16 × 4C | | | 90 | Approx. 11.1 | UL AWM 2501 |
| 9) Linear servo (up to 10 m) | Long bending life SC-EPWS2CBL_M-H | AWG 19 × 4C | ETFE | | 40 | Approx. 5.7 | UL AWM 2103 |
| 10) Linear servo (more than 10 m)/junction connection to rotary servo (more than 10 m) | | AWG 14 × 4C | | | 75 | Approx. 10.5 | UL AWM 2501 |

A symbol "_" in the model name indicates a cable length.

A symbol "*" in the model name is "A1" or "A2". A1: Load-side lead, A2: Opposite to load-side lead.

The characters "-H" or "-L" at the end of a model name indicate a bending life. A model name with the characters "-H" has a long bending life, and "-L" has a standard bending life.

APPENDIX

(2) Dimensions

[Unit: mm]

1) [SC-EMP01CBL_M-L]

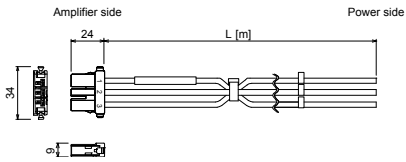

2) [SC-ECP01CBL_M-L]

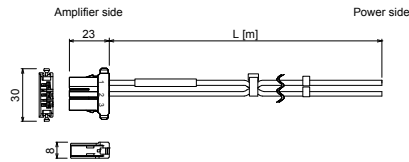

3) [SC-ERG01CBL_M-L]

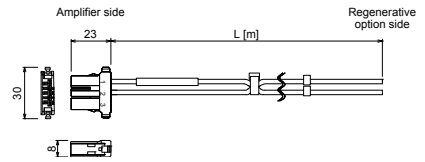

4) [SC-ERG02CBL01M-L]

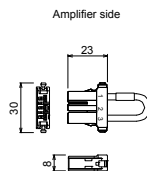

5)6) [SC-EPWS1CBL_M-*-L/ SC-EPWS1CBL_M-*-H]

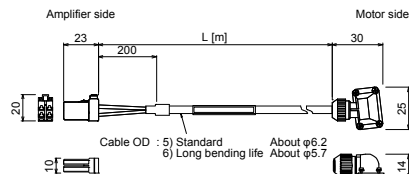

7)8)9)10) [SC-EPWS2CBL_M-L/ SC-EPWS2CBL_M-H]

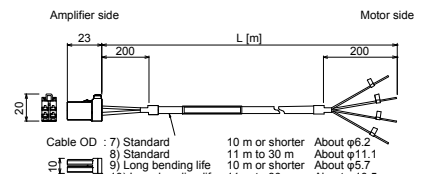

A symbol "_" in the model name indicates a cable length.

A symbol "*" in the model name is "A1" or "A2". A1: Load-side lead, A2: Opposite to load-side lead.

APPENDIX

App. 12 Special specification

App. 12.1 Amplifier without dynamic brake

App. 12.1.1 Summary

This section explains servo amplifiers without dynamic brakes. Items not given in this section will be the same as MR-J4W_ _ _ B_ _.

App. 12.1.2 Model

The following describes what each block of a model name indicates. Not all combinations of the symbols are available.

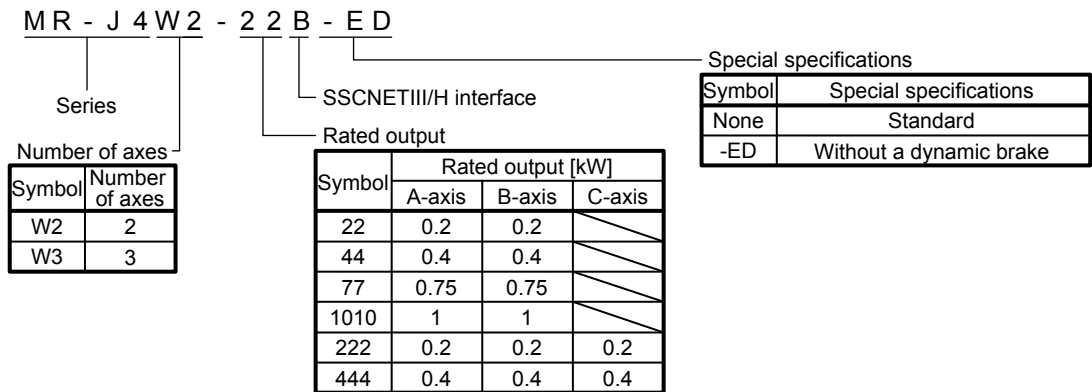

App. 12.1.3 Specifications

The dynamic brake built-in the servo amplifier is removed.

Take safety measures such as making another circuit in case of an emergency stop, alarm, and servo motor stop at power supply shut-off.

When the following servo motors are used, the electronic dynamic brake can start at an alarm occurrence.

| Series | Servo motor |
|--------|----------------------------------|
| HG-KR | HG-KR053/HG-KR13/HG-KR23/HG-KR43 |
| HG-MR | HG-MR053/HG-MR13/HG-MR23/HG-MR43 |
| HG-SR | HG-SR51/HG-SR52 |

Setting the following parameter disables the electronic dynamic brake.

| Servo amplifier | Parameter | Setting value |
|------------------|------------|---------------|
| MR-J4W_ _ _ B-ED | [Pr. PF06] | _ _ _ 2 |

When "2 _ _ _" (initial value) is set in [Pr. PA04], a forced stop deceleration can start at an alarm occurrence. Setting "0 _ _ _" in [Pr. PA04] disables the forced stop deceleration.

APPENDIX

App. 12.2 Special coating-specification product (IEC 60721-3-3 Class 3C2)

App. 12.2.1 Summary

This section explains servo amplifiers with a special coating specification. Items not given in this section will be the same as MR-J4W_-_B_.

App. 12.2.2 Model

The following describes what each block of a model name indicates. Not all combinations of the symbols are available.

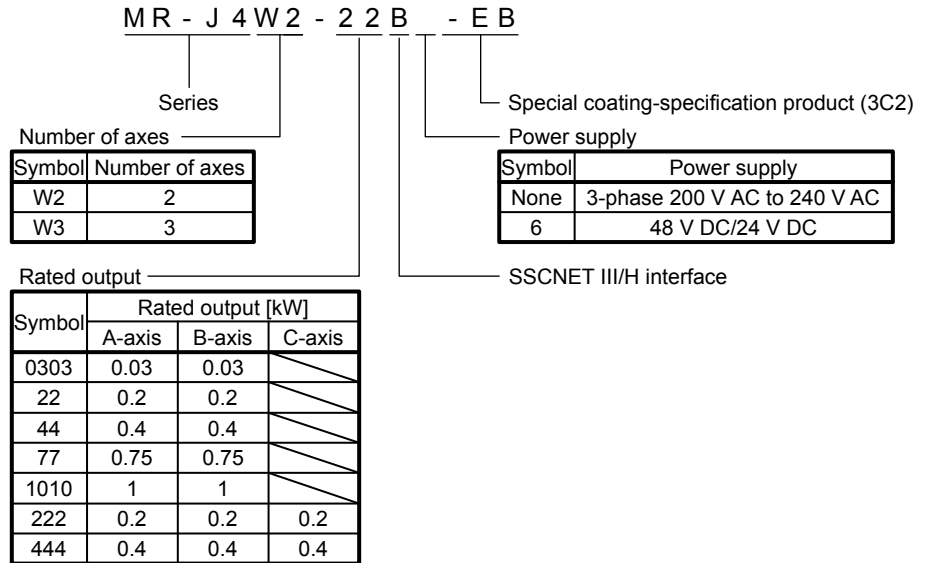

APPENDIX

App. 12.2.3 Specifications

(1) Special coating

Using the MR-J4 series in an atmosphere containing a corrosive gas may cause its corrosion with time, resulting in a malfunction. For the printed circuit board of the servo amplifiers with a special coating specification, a urethane coating agent is applied to some parts capable of being coated technically (except LEDs, connectors, terminal blocks, etc.) to improve the resistance to corrosive gases. Use a servo amplifier with a special coating specification specifically for applications susceptible to corrosive gases, including tire manufacturing and water treatment. Although the special coating-specification products have the improved resistance to corrosive gases, proper operations in environments mentioned above are not guaranteed. Therefore, perform periodic inspections for any abnormality.

(2) Standard for corrosive gases

In IEC 60721-3-3, corrosive gases refer to sea salt, sulfur dioxide, hydrogen sulfide, chlorine, hydrogen chloride, hydrogen fluoride, ammonia, ozone, and nitrogen oxides shown in the environmental parameter column of the table below.

The table also shows the corrosive gas concentrations defined in IEC 60721-3-3, Class 3C2.

| Environmental parameter | Unit | 3C2 | |
|-------------------------|---------------------------------|------------|---------------|
| | | Mean value | Maximum value |
| a) Sea salt | None | Salt mist | |
| b) Sulfur dioxide | cm ³ /m ³ | 0.11 | 0.37 |
| c) Hydrogen sulfide | cm ³ /m ³ | 0.071 | 0.36 |
| d) Chlorine | cm ³ /m ³ | 0.034 | 0.1 |
| e) Hydrogen chloride | cm ³ /m ³ | 0.066 | 0.33 |
| f) Hydrogen fluoride | cm ³ /m ³ | 0.012 | 0.036 |
| g) Ammonia | cm ³ /m ³ | 1.4 | 4.2 |
| h) Ozone | cm ³ /m ³ | 0.025 | 0.05 |
| i) Nitrogen oxides | cm ³ /m ³ | 0.26 | 0.52 |

The special coating-specification products have the improved corrosion resistance in environments with corrosive gas concentrations conforming to IEC 60721-3-3, Class 3C2. We tested typical models and confirmed that their corrosive gas resistance was improved, compared with the standard models.

APPENDIX

App. 13 Driving on/off of main circuit power supply with DC power supply

App. 13.1 Connection example

The following is common in 200 W or more MR-J4W_ _B servo amplifiers. For the signals and wiring that are not described in this section, refer to section 3.1.

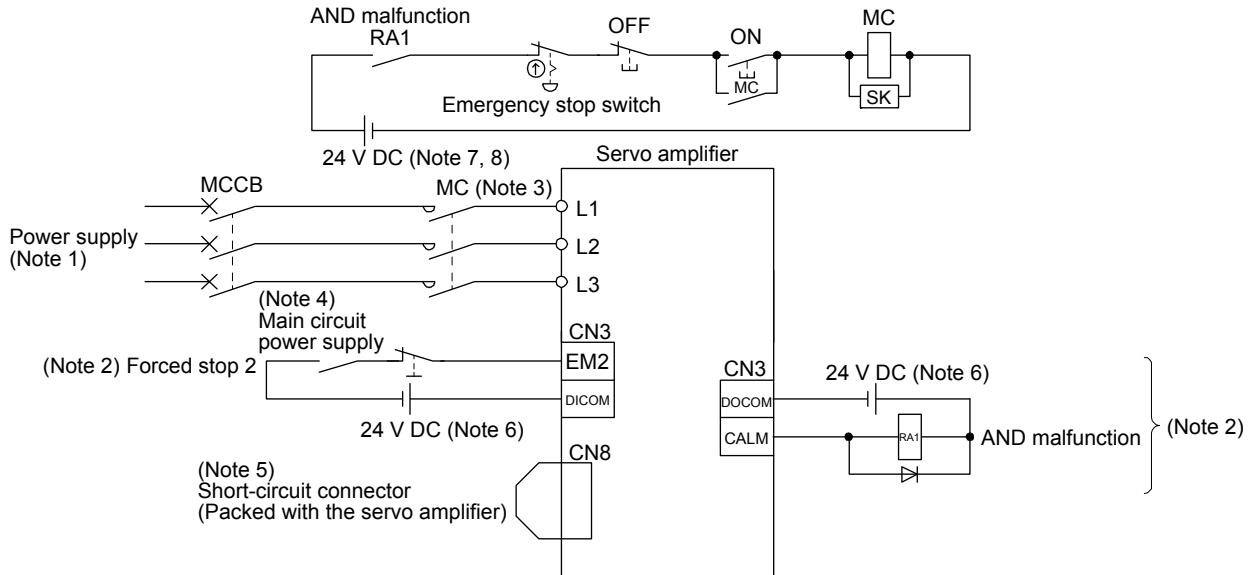

Note 1. For the power supply specifications, refer to section 1.3.

Note 2. This diagram shows sink I/O interface. For source I/O interface, refer to section 3.8.3.

Note 3. Use a magnetic contactor with an operation delay time (interval between current being applied to the coil until closure of contacts) of 80 ms or less. Depending on the main circuit voltage and operation pattern, bus voltage decreases, and that may cause the forced stop deceleration to shift to the dynamic brake deceleration. When dynamic brake deceleration is not required, slow the time to turn off the magnetic contactor.

Note 4. Configure a circuit to turn off EM2 when the main circuit power is turned off to prevent an unexpected restart of the servo amplifier.

Note 5. When not using the STO function, attach the short-circuit connector came with a servo amplifier.

Note 6. The illustration of the 24 V DC power supply is divided between input signal and output signal for convenience. However, they can be configured by one.

Note 7. Driving the on switch and off switch with the DC power supply meets IEC/EN 60204-1 requirements.

Note 8. Do not use the 24 V DC interface power supply for the magnetic contactor DC power supply. Always use the power supply designed exclusively for the magnetic contactor.

APPENDIX

App. 13.2 Magnetic contactor

Use a magnetic contactor with an operation delay time (interval between current being applied to the coil until closure of contacts) of 80 ms or less.

(1) For MR-J4W2

| Total output of rotary servo motors | Total continuous thrust of linear servo motors | Total output of direct drive motors | Magnetic contactor |
|-------------------------------------|------------------------------------------------|-------------------------------------|--------------------|
| 300 W or less | | | SD-N11 |
| From over 300 W to 600 W | 150 N or less | 100 W or less | |
| From over 600 W to 1 kW | From over 150 N to 300 N | From over 100 W to 252 W | |
| From over 1 kW to 2 kW | From over 300 N to 720 N | From over 252 W to 838 W | SD-N21 |

(2) For MR-J4W3

| Total output of rotary servo motors | Total continuous thrust of linear servo motors | Total output of direct drive motors | Magnetic contactor |
|-------------------------------------|------------------------------------------------|-------------------------------------|--------------------|
| 450 W or less | 150 N or less | | SD-N11 |
| From over 450 W to 800 W | From over 150 N to 300 N | 252 W or less | |
| From over 800 W to 1.5 kW | From over 300 N to 450 N | From over 252 W to 378 W | SD-N21 |

APPENDIX

App. 14 Optional data monitor function

The optional data monitor function is used to monitor data in the servo amplifier with the servo system controller. In the optional data monitor function, data types of registered monitor and transient command can be set.

For details of usage, unit of data type, and others, refer to the manuals for servo system controllers.

App. 14.1 Registered monitor

| Data type | Description |
|----------------------------------------|-------------------------------------------------------------------------------------------------------------------------------------------------------------------------------------------------------------------------------------------------------------------------------------------------------------------------------------------|
| Effective load ratio | The continuous effective load current is displayed. The effective value is displayed considering a rated current as 100%. |
| Regenerative load ratio | The ratio of regenerative power to permissible regenerative power is displayed in %. |
| Peak load ratio | The maximum torque generated is displayed. The highest value in the past 15 s is displayed, with the rated torque being 100%. |
| Position feedback | Feedback pulses from the servo motor encoder are counted and displayed. |
| Encoder position within one revolution | The position in servo motor-side 1-revolution is displayed in the encoder pulse unit. When the value exceeds the maximum number of pulses, it resets to 0. |
| Encoder multiple revolution counter | The rotation amount of the servo motor is displayed. The value is counted up by one per servo motor revolution. |
| Load inertia moment ratio | The set ratio of the load inertia moment to the servo motor shaft inertia moment is displayed. |
| Load mass ratio | The load to mass of the linear servo motor primary-side ratio is displayed. |
| Model loop gain | The model loop gain value is displayed. |
| Main circuit bus voltage | The voltage of main circuit converter (between P+ and N-) is displayed. |
| Cumulative current value | The cumulative current value of the servo motor is displayed. |
| Servo motor speed | The servo motor speed is displayed. |
| Servo motor speed | The linear servo motor speed is displayed at linear servo motor driving. |
| Selected droop pulse | The droop pulse set in [Pr. PE10] is displayed. |
| Module power consumption | The module power consumption is displayed. The positive value is displayed in power running. The negative value is displayed in regeneration. |
| Module integral power consumption | The module integral power consumption is displayed. |
| Instantaneous torque | The instantaneous torque is displayed. The value of torque being occurred is displayed in real time considering a rated torque as 100%. |
| Instantaneous thrust | The instantaneous thrust is displayed at linear servo motor driving. The value of thrust being occurred is displayed in real time considering a continuous thrust as 100%. |
| Load-side encoder information 1 | When an incremental type linear encoder is used for the load-side encoder, the Z-phase counter of the load-side encoder is displayed by encoder pulses. When an absolute position type linear encoder is used for the load-side encoder, the encoder absolute position is displayed. |
| Load-side encoder information 2 | When an incremental type linear encoder is used for the load-side encoder, the display shows 0. When an absolute position type linear encoder is used for the load-side encoder, the display shows 0. When a rotary encoder is used for the load-side encoder, the display shows the multi-revolution counter value of the encoder. |
| Z-phase counter | The Z-phase counter is displayed in the encoder pulse unit. For an incremental type linear encoder, the Z-phase counter is displayed. The value is counted up from 0 based on the home position (reference mark). For an absolute position type linear encoder, the encoder absolute position is displayed. |
| Servo motor thermistor temperature | The thermistor temperature is displayed for the servo motor with a thermistor. For the servo motor without thermistor, "9999" is displayed. For the servo motor with a thermistor, refer to each servo motor instruction manual. |
| Disturbance torque | The difference between the torque necessary to drive the servo motor and the actually required torque (Torque current value) is displayed as the disturbance torque. |
| Disturbance thrust | The difference between the thrust necessary to drive the linear servo motor and the actually required thrust (Thrust current value) is displayed as the disturbance thrust. |

APPENDIX

| Data type | Description |
|-----------------------------------------------|-----------------------------------------------------------------------------------------------------------------------------------------------------------------------------------------------------------------------------------------------------------------------------|
| Overload alarm margin | The margins to the levels which trigger [AL. 50 Overload 1] and [AL. 51 Overload 2] are displayed in percentage. |
| Error excessive alarm margin | The margin to the level which triggers the error excessive alarm is displayed in units of encoder pulses. The error excessive alarm occurs at 0 pulses. |
| Settling time | The time (Settling time) after command is completed until INP (In-position) turns on is displayed. |
| Overshoot amount | The overshoot amount during position control is displayed in units of encoder pulses. |
| Servo motor side/load-side position deviation | During fully closed loop control, a deviation between servo motor side position and load-side position is displayed. The number of pulses displayed is in the load-side encoder pulse unit. |
| Servo motor side/load-side speed deviation | During fully closed loop control, a deviation between servo motor side speed and load-side speed is displayed. |
| Internal temperature of encoder | The internal temperature of encoder is displayed. "0" is displayed for the linear servo motor. When an encoder communication error occurs, the last value will be displayed before the error. This is available with servo amplifiers with software version C4 or later. |
| Servo command value | The position command from the controller is displayed. |
| Torque command | The torque command from the controller is displayed. |

App. 14.2 Transient command

| Data type | Description |
|--------------------------------------------------------------|-----------------------------------------------------------------------------------------------------------------------------------------------------------------------------------------------------------------------------------------|
| Motor serial number (First 8 characters) | The servo motor serial number is displayed. |
| Motor serial number (Last 8 characters) | The serial number is not displayed for linear servo motors. This data type is available with servo amplifier with software version C8 or later. |
| Servo motor ID (SSCNET III)/Encoder ID | The servo motor ID and encoder ID sent from the encoder are displayed. The types of the connected servo motor and encoder can be checked by referring to the ID. For details, refer to "Servo Motor Instruction Manual (Vol. 3)". |
| Servo motor ID (SSCNET III/H) | The servo motor ID sent from the encoder is displayed. The type of the connected servo motor can be checked by referring to the ID. For details, refer to "Servo Motor Instruction Manual (Vol. 3)". |
| Encoder resolution | The encoder resolution is displayed. |
| Servo amplifier serial number (First 8 characters) | The servo amplifier serial number is displayed. |
| Servo amplifier serial number (Last 8 characters) | |
| Servo amplifier recognition information (First 8 characters) | The servo amplifier name is displayed. |
| Servo amplifier recognition information (Last 8 characters) | |
| Servo amplifier software number (First 8 characters) | The software version of the servo amplifier is displayed. |
| Servo amplifier software number (Last 8 characters) | |
| Power ON cumulative time | The cumulative time after power on of the servo amplifier is displayed. |
| Inrush relay ON/OFF number | The number of on and off for inrush relay of the servo amplifier is displayed. |
| Read alarm history number | The maximum number of alarm histories of the connected servo amplifier is displayed. |
| Alarm history/Detail #1, #2 | The alarm history/detail #1, #2 are displayed. (Hexadecimal) |
| Alarm history/Detail #3, #4 | The alarm history/detail #3, #4 are displayed. (Hexadecimal) |
| Alarm history/Detail #5, #6 | The alarm history/detail #5, #6 are displayed. (Hexadecimal) |
| Alarm history/Detail #7, #8 | The alarm history/detail #7, #8 are displayed. (Hexadecimal) |
| Alarm history/Detail/Occurrence time | The alarm history data of specific number # is displayed. |
| Alarm occurrence time #1, #2 | The alarm occurrence time #1, #2 are displayed. |
| Alarm occurrence time #3, #4 | The alarm occurrence time #3, #4 are displayed. |
| Alarm occurrence time #5, #6 | The alarm occurrence time #5, #6 are displayed. |
| Alarm occurrence time #7, #8 | The alarm occurrence time #7, #8 are displayed. |
| Alarm history clear command | Used for alarm history clear. |

APPENDIX

| Data type | Description |
|-----------------------------------------------|-------------------------------------------------------------------------------------------------------------------------------------------------------------------------------------------------------------------------------------------------------------------------------------------------------------------------------------------|
| Home position [command unit] | The home position is displayed. |
| Main circuit bus voltage | The voltage of main circuit converter (between P+ and N-) is displayed. |
| Regenerative load ratio | The ratio of regenerative power to permissible regenerative power is displayed in %. |
| Effective load ratio | The continuous effective load current is displayed. The effective value is displayed considering a rated current as 100%. |
| Peak load ratio | The maximum torque generated is displayed. The highest value in the past 15 s is displayed, with the rated torque being 100 %. |
| Estimate inertia moment ratio | The set ratio of the load inertia moment to the servo motor shaft inertia moment is displayed. |
| Model loop gain | The model loop gain value is displayed. |
| LED display | The value shown on the 7-segment LED display of the servo amplifier is displayed. |
| Load-side encoder information 1 | When an incremental type linear encoder is used for the load-side encoder, the Z-phase counter of the load-side encoder is displayed by encoder pulses. When an absolute position type linear encoder is used for the load-side encoder, the encoder absolute position is displayed. |
| Load-side encoder information 2 | When an incremental type linear encoder is used for the load-side encoder, the display shows 0. When an absolute position type linear encoder is used for the load-side encoder, the display shows 0. When a rotary encoder is used for the load-side encoder, the display shows the multi-revolution counter value of the encoder. |
| Speed feedback | The servo motor speed is displayed. |
| Servo motor thermistor temperature | The thermistor temperature is displayed for the servo motor with a thermistor. For the servo motor without thermistor, "9999" is displayed. For the servo motor with a thermistor, refer to each servo motor instruction manual. |
| Z-phase counter | The Z-phase counter is displayed in the encoder pulse unit. For an incremental type linear encoder, the Z-phase counter is displayed. The value is counted up from 0 based on the home position (reference mark). For an absolute position type linear encoder, the encoder absolute position is displayed. |
| Module power consumption | The module power consumption is displayed. The positive value is displayed in power running. The negative value is displayed in regeneration. |
| Module integral power consumption | The module integral power consumption is displayed. |
| Disturbance torque | The difference between the torque necessary to drive the servo motor and the actually required torque (Torque current value) is displayed as the disturbance torque. |
| Instantaneous torque | The instantaneous torque is displayed. The value of torque being occurred is displayed in real time considering a rated torque as 100%. |
| Overload alarm margin | The margins to the levels which trigger [AL. 50 Overload 1] and [AL. 51 Overload 2] are displayed in percentage. |
| Error excessive alarm margin | The margin to the level which triggers the error excessive alarm is displayed in units of encoder pulses. The error excessive alarm occurs at 0 pulses. |
| Settling time | The time (Settling time) after command is completed until INP (In-position) turns on is displayed. |
| Overshoot amount | The overshoot amount during position control is displayed in units of encoder pulses. |
| Servo motor side/load-side position deviation | During fully closed loop control, a deviation between servo motor side position and load-side position is displayed. The number of pulses displayed is in the load-side encoder pulse unit. |
| Servo motor side/load-side speed deviation | During fully closed loop control, a deviation between servo motor side speed and load-side speed is displayed. |
| Internal temperature of encoder | The internal temperature of encoder is displayed. "0" is displayed for the linear servo motor. When an encoder communication error occurs, the last value will be displayed before the error. This is available with servo amplifiers with software version C4 or later. |
| Machine diagnostic status | The current status of the machine diagnostic function is displayed. |
| Friction estimation data | The friction estimation data estimated by the machine diagnostic function is displayed. |
| Vibration estimation data | The vibration estimation data estimated by the machine diagnostic function is displayed. |

APPENDIX

App. 15 STO function with SIL 3 certification

The MR-J4 series general-purpose AC servo amplifiers now comply with safety integrity level 3 (SIL 3) of the IEC 61508:2010 functional safety standard.

App. 15.1 Target models

MR-J4 series AC servo amplifiers (excluding MR-J4-03A6(-RJ) and MR-J4W2-0303B6)

App. 15.2 Change of the compliance

The target MR-J4 servo amplifiers now comply with SIL 3 (Table app. 3).

Table app. 3 Compliance with SIL 3

| | Before change | After change |
|---------------------------------------------------|--------------------------------------------------------------------------------------------------------|--------------------------------------------------------------------------------------------------------|
| Safety performance (Standards certified by CB) | EN ISO 13849-1 Category 3 PL d, IEC 61508 SIL 2, EN 62061 SIL CL 2, EN 61800-5-2 STO function | EN ISO 13849-1 Category 3 PL e, IEC 61508 SIL 3, EN 62061 SIL CL 3, EN 61800-5-2 STO function |

App. 15.3 Schedule

For the products manufactured in Japan, this change has been made sequentially from the June 2015 production.

For the products manufactured and sold in China, this change has been made sequentially from the December 2015 production.

There may be cases where both the former and new products exist in the distribution stage.

App. 15.4 Use with SIL 3

Set the safety level with [Pr. PF18 STO diagnosis error detection time].

To use the servo amplifier with SIL 3, set [Pr. PF18 STO diagnosis error detection time] within the range of 1 to 60, connect the TOFB output (CN8) of the servo amplifier to the input of a SIL 3-certified controller and execute the diagnosis. SIL 3 functional safety of the servo amplifiers is certified by TÜV SÜD.

App. 15.5 Use with SIL 2 (as conventional)

The servo amplifiers are still capable of SIL 2 as before regardless of whether the STO diagnosis function is enabled or not.

Either of the conventionally-used TÜV Rheinland certification or the new TÜV SÜD certification may be used.

APPENDIX

App. 15.6 How to check the country of origin, and the year and month of manufacture

The country of origin, and the year and month of manufacture are indicated on the packaging box (Fig. app. 2) and the rating plate (Fig. app. 3).

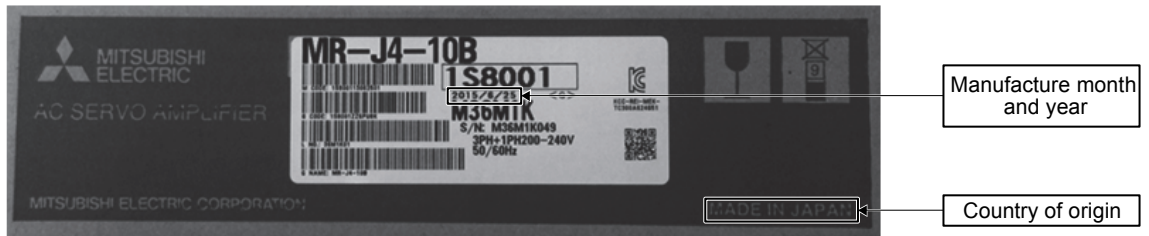

Fig. app. 2 Indication example on the packaging box

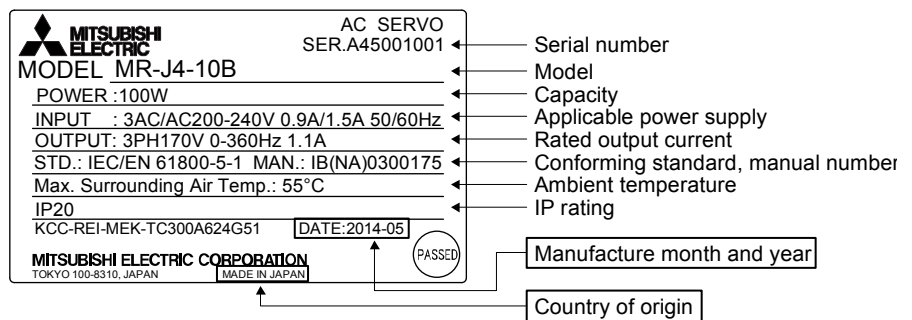

Fig. app. 3 Indication example on the rating plate

APPENDIX

App. 16 Status of general-purpose AC servo products for compliance with the China RoHS directive





(1) Summary

The China RoHS directive: 电子信息产品污染控制管理办法 (Management Methods for Controlling Pollution by Electronic Information Products) came into effect on March 1, 2007. The China RoHS directive was replaced by the following China RoHS directive: 电器电子产品有害物质限制使用管理办法 (Management Methods for the Restriction of the Use of Hazardous Substances in Electrical and Electronic Products). The succeeding China RoHS directive has been in effect since July 1, 2016. The China RoHS directive restricts the use of six hazardous substances (lead, mercury, cadmium, hexavalent chromium, polybrominated biphenyls (PBB), and polybrominated diphenyl ethers (PBDE)) and other hazardous substances specified by the State (currently no applicable substances). The EU RoHS directive (2011/65/EU) also restricts the use of the above six hazardous substances.

(2) Status of our products for compliance with the China RoHS directive

The following tables show the content of six hazardous substances in our products and Environment-Friendly Use Period marks. Table app. 4 is created based on the standard SJ/T11364.

Table app. 4 Names and the content of hazardous substances in the products

| Substance name Threshold standard | | Hazardous substance (Note 1) | | | | | | Environment-Friendly Use Period mark (Note 2) | Remark |
|--------------------------------------|-----------------|-------------------------------------------------------------------------------------------------------------|--------------|--------------|------------------------------|-----|------|---------------------------------------------------------------------------------------|-------------------------|
| | | Lead (Pb) | Mercury (Hg) | Cadmium (Cd) | Hexavalent chromium (Cr(VI)) | PBB | PBDE | | |
| Part name | | Threshold of cadmium: 0.01 wt% (100 ppm), Threshold of substances other than cadmium: 0.1 wt% (1000 ppm) | | | | | | | |
| Servo amplifier | Mounting board | × | ○ | ○ | ○ | ○ | ○ |  | / |
| | Heat sink | × | ○ | ○ | ○ | ○ | ○ | | |
| | Resin cabinet | ○ | ○ | ○ | ○ | ○ | ○ | | |
| | Plate and screw | ○ | ○ | ○ | ○ | ○ | ○ | | |
| Servo motor | Bracket | × | ○ | ○ | ○ | ○ | ○ |  | / |
| | Mounting board | × | ○ | ○ | ○ | ○ | ○ | | |
| | Resin cabinet | ○ | ○ | ○ | ○ | ○ | ○ | | |
| | Core and cable | ○ | ○ | ○ | ○ | ○ | ○ | | |
| Cable product | Cable | ○ | ○ | ○ | ○ | ○ | ○ |  | Including connector set |
| | Connector | ○ | ○ | ○ | ○ | ○ | ○ | | |
| Optional unit | Mounting board | × | ○ | ○ | ○ | ○ | ○ |  | / |
| | Resin cabinet | ○ | ○ | ○ | ○ | ○ | ○ | | |
| | Plate and screw | ○ | ○ | ○ | ○ | ○ | ○ | | |

Note 1. ○: Indicates that said hazardous substance contained in all of the homogeneous materials for this part is below the limit requirement of GB/T26572.

×: Indicates that said hazardous substance contained in at least one of the homogeneous materials for this part is above the limit requirement of GB/T26572.

2. Indications based on "Marking for the restriction of the use of hazardous substances in electrical and electronic product" [SJ/T11364-2014]



Indicates that a certain hazardous substance is contained in the product manufactured or sold in China. Observe safety and usage precautions for the product, and use it within a limited number of years from the production date. Thereby, any of the hazardous substances in the product does not cause environmental pollution, or seriously affect human health or property.



Indicates that no certain hazardous substance is contained in the product.

APPENDIX

(3) Difference between the China RoHS directive and the EU RoHS directive

The China RoHS directive allows no restriction exemption unlike the EU RoHS directive. Although a product complies with the EU RoHS directive, a hazardous substance in the product may be considered to be above the limit requirement (marked "x") in the China RoHS directive.

The following shows some restriction exemptions and their examples according to the EU RoHS directive.

- Lead as an alloying element in steel for machining purposes and in galvanized steel containing up to 0.35% lead by weight, lead as an alloying element in aluminum containing up to 0.4% lead by weight, and copper alloy containing up to 4% lead by weight, e.g. brass-made insert nuts
- Lead in high melting temperature type solders (i.e. lead-based alloys containing 85% by weight or more lead)
- Electrical and electronic components containing lead in a glass or ceramic other than dielectric ceramic in capacitors, e.g. piezoelectric devices
- Electrical and electronic components containing lead in a glass or ceramic matrix compound, e.g. chip resistors

(4) Status of our products for compliance with the China RoHS directive (Chinese)

The following shows table app. 4 in Chinese according to "Management Methods for the Restriction of the Use of Hazardous Substances in Electrical and Electronic Products".

表附. 5 产品中所含有害物质的名称及含量

| 部件名称 | 物质名称 阈值 基准 | 有害物质 (注1) | | | | | | 环境保护 使用期限标识 (注2) | 备注 |
|-------------|------------------|--------------------------------------------------|-----------|-----------|-----------------|-----|------|---------------------------------------------------------------------------------------|---------|
| | | 铅 (Pb) | 汞 (Hg) | 镉 (Cd) | 六价铬 (Cr(VI)) | PBB | PBDE | | |
| | | 阈值: 镉: 0.01wt%(100ppm)、 镉以外: 0.1wt%(1000ppm)、 | | | | | | | |
| 伺服放大器 | 电路板组件 | x | ○ | ○ | ○ | ○ | ○ |  | |
| | 散热片 | x | ○ | ○ | ○ | ○ | ○ | | |
| | 树脂壳体 | ○ | ○ | ○ | ○ | ○ | ○ | | |
| 伺服系统 控制器 | 金属板、螺丝 | ○ | ○ | ○ | ○ | ○ | ○ |  | |
| | 托架 | x | ○ | ○ | ○ | ○ | ○ | | |
| 伺服电机 | 电路板组件 | x | ○ | ○ | ○ | ○ | ○ |  | |
| | 树脂壳体 | ○ | ○ | ○ | ○ | ○ | ○ | | |
| | 铁心、电线 | ○ | ○ | ○ | ○ | ○ | ○ | | |
| 电缆 加工品 | 电线 | ○ | ○ | ○ | ○ | ○ | ○ |  | 包括连接器组件 |
| | 连接器 | ○ | ○ | ○ | ○ | ○ | ○ | | |
| 选件 模块 | 电路板组件 | x | ○ | ○ | ○ | ○ | ○ |  | |
| | 树脂壳体 | ○ | ○ | ○ | ○ | ○ | ○ | | |
| | 金属板、螺丝 | ○ | ○ | ○ | ○ | ○ | ○ | | |

注 1. ○: 表示该有害物质在该部件所有均质材料中的含量均在GB/T26572规定的限量要求以下。
x: 表示该有害物质在该部件的至少一种均质材料中的含量超出GB/T26572规定的限量要求。

2. 根据“电子电气产品有害物质限制使用标识要求”、[SJ/T11364-2014]的表示



该标志表示在中国制造/销售的产品中含有特定有害物质。

只要遵守本产品的安全及使用方面的注意事项，从生产日算起的环保使用期限内不会造成环境污染或对人体、财产产生深刻的影响。



该标志表示制造的产品中不含有特定有害物质。

REVISIONS

*The manual number is given on the bottom left of the back cover.

| Revision Date | *Manual Number | Revision | |
|---------------|-------------------|-----------------------------------------------------------|----------------------------------------------------------------------------------------------------------|
| Mar. 2012 | SH(NA)030105ENG-A | First edition | |
| Jun. 2012 | SH(NA)030105ENG-B | 4. Additional instructions (2) Wiring | The sentences are added. |
| | | 4. Additional instructions (3) Test run and adjustment | The sentences are added. |
| | | COMPLIANCE WITH CE MARKING | The reference is changed. |
| | | COMPLIANCE WITH UL/CSA STANDARD | The reference is changed. |
| | | COMPLIANCE WITH KC MARK | Added. |
| | | Section 1.2 | The diagram is changed. |
| | | Section 1.3.1 | The table is changed. Note 8 is added. |
| | | Section 1.3.2 | The table is changed. Note 7 and 8 is added. |
| | | Section 1.4 | The item of the drive recorder function is changed. The item of the fully closed loop system is changed. |
| | | Section 1.6 | The diagram is changed. |
| | | Section 1.7 | Note is changed. |
| | | Section 2.6 | The explanation of relay lifetime is changed. |
| | | Chapter 3 | The sentences are added to CAUTION. |
| | | Section 3.1 | The sentences are added to CAUTION. Note 12 is added. |
| | | Section 3.2.1 | Note 20 is added. |
| | | Section 3.2.2 | Note 20 is added. |
| | | Section 3.3.3 (2) (a) | The ferrule is added. |
| | | Section 3.4 | The diagram is added. |
| | | Section 3.5.2 (2) | The sentences of INP (In-position) are added. CLDS (During fully closed loop control) is added. |
| | | Section 3.7.1 (3) | The sentences are added. |
| | | Section 3.8.2 (1) | The sentences are changed. |
| | | Section 3.8.2 (2) | The sentences are added. |
| | | Section 3.8.3 (1) | The sentences are added. |
| | | Section 3.8.3 (2) | The sentences are added. |
| | | Section 4.1.2 (1) (b) 1) | The sentences are changed. |
| | | Section 4.1.2 (1) (b) 4) | Added. |
| | | Section 4.3.3 (1) | The diagram is changed. |
| | | Section 4.5.2 (1) (b) | Note is added. [AL. 20 Encoder normal communication error 1 (ABZ input)] in the table is deleted. |
| | | Section 5.1 | POINT is changed and Note is deleted. |
| | | Section 5.1.1 | PA25 is changed from "For manufacturer setting". |
| | | Section 5.1.6 | PF06 and PF12 are changed from "For manufacturer setting". |
| | | Section 5.2.1 | The sentences are added to PA01 and PA20, and PA25 is added. |
| | | Section 5.2.3 | The sentences of PC01 are changed and sentences are added to PC03. |
| | | Section 5.2.4 | The table of PD07 is changed. |
| | | Section 5.2.5 | The sentences are added to PE08. |
| | | Section 5.2.6 | PF06 and PF12 are added. |
| | | Chapter 6 | The sentences in POINT are changed. |
| | | Section 6.2.2 (4) | The part of table is changed. |
| | | Chapter 7 | The sentences in POINT are changed. |
| | | Section 7.3.1 | The sentences are added to POINT. |

| Revision Date | *Manual Number | Revision | |
|---------------|-------------------|------------------------|---------------------------------------------------------------------------------------------------------------------------------------------------------------------------------------------------|
| Jun. 2012 | SH(NA)030105ENG-B | Section 8.1 | The column of the fully closed loop control is added. [AL. 13.2], [AL. 1E.2], [AL. 1F.2], [AL. 21.4], [AL. 42.8], [AL. 42.9], [AL. 42.A], [AL. 70], [AL. 71], [AL. 72], and [AL. E8.2] are added. |
| | | Section 8.2 | The troubleshooting for the MR-J4W3 servo amplifiers with software version A2 or below. |
| | | Section 10.3 | POINT is added. |
| | | Section 11.2.2 | The title is changed. |
| | | Section 11.4 | Note is changed. |
| | | Section 12.2 | The sentences are added to POINT. |
| | | Section 13.1.5 | The value in table is changed. |
| | | Section 13.3.2 (1) | The diagram is changed. |
| | | Section 13.3.2 (2) | Added. |
| | | Section 13.3.3 | The part of diagram is changed. |
| | | Section 13.4.1 (1) | The sentences are changed. |
| | | Section 13.4.1 (2) | The sentences are added. |
| | | Section 13.4.1 (2) (a) | Note is changed. |
| | | Section 13.4.2 (1) | The sentences are added. |
| | | Section 13.4.2 (2) | The sentences are added. |
| | | Section 14.1.2 | CAUTION is changed. |
| | | Section 14.2 | CAUTION is added. |
| | | Section 14.3.1 (1) | The diagram is added. |
| | | Section 14.3.1 (2) | "Set the linear servo motor series and linear servo motor type" is added. |
| | | Section 14.3.2 (3) (a) | POINT and sentences are changed. |
| | | Section 14.3.2 (3) (b) | POINT is changed. |
| | | Section 14.4.4 | The table is changed and the sentences are added. CAUTION is changed. |
| | | Section 15.2 | CAUTION is added. |
| | | Section 15.3.2 (3) (a) | POINT and sentences are changed. |
| | | Section 15.3.2 (3) (b) | POINT is changed. |
| | | Section 15.4.3 (2) | The table is changed. |
| | | Chapter 16 | "Available in the future" is deleted. The sentences in POINT are changed. |
| | | Section 16.1.1 | The sentences of Note 2 are changed. |
| | | Section 16.1.2 (1) | The part of diagram is changed. |
| | | Section 16.3.1 (5) | The part of table is changed. |
| | | Appendix. 4 | The sentences are changed. |
| | | Appendix. 5 | The sentences are changed. |
| | | Appendix. 6 | The sentences are changed. |
| | | Appendix. 7.7.3 (1) | POINT and diagram are changed. |
| | | Appendix. 7.7.3 (2) | The diagram is changed. |
| | | Appendix. 7.7.3 (3) | Deleted. |
| | | Appendix. 7.7.3 (4) | Deleted. |
| | | Appendix. 7.8.1 (1) | The pin number is changed and Note is deleted. |
| | | Appendix. 7.8.1 (2) | CAUTION is deleted. |
| | | Appendix. 7.8.2 | The sentences are changed. |
| | | Appendix. 7.12 | The diagram is added. |
| | | Appendix. 7.14 | POINT is changed. |
| | | Appendix. 8 | TUV certificate of MR-J4 series is added. |
| | | Appendix. 10.1 | The diagram is changed. |
| | | Appendix. 13 (1) | The wire size of 6) is changed. |
| | | Appendix. 14 | Added. |
| Sep. 2012 | SH(NA)030105ENG-C | Section 3.2.1 | The diagram is changed. |
| | | Section 3.2.2 | The diagram is changed. |
| | | Section 3.10.2 (1) (b) | The diagram is changed. |
| | | Section 13.3.1 | The sentences are changed. |

| Revision Date | *Manual Number | Revision | |
|---------------|-------------------|-------------------------------------------------------------------------------------------------------------------------------------------------------------------------------------------------------------------------------------------------------------------------------------------------------------------------------------------------------------------------------------------------------------------------------------------------------------------------------------------------------------------------------------------------------------------------------------------------------------------------------------------------------------------------------------------------------------------------------------------------------------------------------------------------------------------------------------------------------------------------------------------------------------------------|--------------------------------------------------------------------------------------------------------------------------------------------------------------------------------------------------------------------------------------------------------------------------------------------------------------------------------------------------------------------------------------------------------------------------------------------------------------------------------------------------------------------------------------------------------------------------------------------------------------------------------------------------------------------------------------------------------------------------------------------------------------------------------------------------------------------------------------------------------------------------------------------------------------------------------------------------------------------------------------------------------------------------------------------------------------------------------------------------------------------------------------------------------------------------------------------------------------------------------------------------------------------------------------------------------------------------------------------------------------------------------------------------------------------------------------------------------------------------------------------------------------------------------------------------------------------------------------------------------------------------------------------------------------------------------------------------------------------------------------------------------------------------------------------------------------------|
| Sep. 2012 | SH(NA)030105ENG-C | Section 13.4.1 (1) Section 13.4.2 (1) | The diagram is changed. The diagram is changed. |
| Feb. 2013 | SH(NA)030105ENG-D | 4. Additional instructions COMPLIANCE WITH CE MARKING COMPLIANCE WITH UL/CSA STANDARD COMPLIANCE WITH KC MARK Compliance with global standards Section 1.3.1 Section 1.3.2 Section 1.3.3 Section 1.4 Chapter 3 Section 3.1 Section 3.3.2 Section 3.4 Section 3.5.2 Section 3.6 Section 3.6.2 Section 3.6.3 Section 3.8.1 Section 3.10.1 (1) Section 4.3.2 (1) Chapter 5 Section 5.1 Section 5.1.4 Section 5.1.6 Section 5.2.1 Section 5.2.2 Section 5.2.3 Section 5.2.6 Section 5.2.7 Section 6.2.2 (2) Section 6.2.2 (4) Section 6.2.2 (5) Section 6.3.1 (1) Section 7.3.2 Section 7.4 Chapter 8 Section 8.1 Section 10.1 Section 10.2 Section 10.3.1 (2) Section 10.3.2 Chapter 11 Section 11.4 (1) Section 11.4 (2) Section 11.5 (1) Section 11.9 (1) (c) | The diagram is partially changed. Deleted. Deleted. Deleted. Added. The table is partially changed. The table is partially changed. The table is changed. HG-UR and HG-JR are added. The table is partially changed. The diagram in CAUTION is partially changed. The diagram is partially changed. POINT is added. The pin name is changed. The table is deleted. The table is partially changed. The sentences are added to POINT. The sentences are partially changed. The sentences are partially changed. The diagram is partially changed. The diagram is partially changed. The diagram is partially changed. The sentences are added to CAUTION. POINT is partially changed. The operation mode in [Pr. PD12] is changed. The name of [Pr. PF25] is changed. The name of the third digit is changed. The sentences in [Pr. PB17], [Pr. PB33] to [Pr. PB36], and [Pr. PB56] to [Pr. PB60] are partially changed. The table in [Pr. PC03] is partially changed. The sentences are added to the fourth digit in [Pr. PC04]. The sentences are added to [Pr. PC05]. The name of [Pr. PF25] is changed. The note is added to the first digit in [Pr. PL04]. POINT is added. The table is partially changed. The sentences are added. POINT is partially changed. CAUTION is deleted. The name of [Pr. PF25] is changed. Added. The sentences are added to POINT. Error reset of watchdog is changed. HG-UR and HG-JR are added. HG-UR and HG-JR are added. HG-UR and HG-JR are added. HG-UR and HG-JR are added. POINT is added. The table is partially changed. The table is partially changed. The diagram is partially changed. The table is partially changed. |

| Revision Date | *Manual Number | Revision | |
|---------------|-------------------|------------------------------------------------------------------------------------------------------------------------------------------------------------------------------------------------------------------------------------------------------------------------------------------------------------------------------------------------------------------------------------------------------------------------------------------------------------------------------------------------------------------------------------|---------------------------------------------------------------------------------------------------------------------------------------------------------------------------------------------------------------------------------------------------------------------------------------------------------------------------------------------------------------------------------------------------------------------------------------------------------------------------------------------------------------------------------------------------------------------------------------------------------------------------------------------------------------------------------------------------------------------|
| Feb. 2013 | SH(NA)030105ENG-D | Section 13.2.2 (2) Section 13.2.2 (3) Section 14.2 Section 14.3.5 (2) (a) Section 15.2 Section 15.3.3 (2) Section 16.1.3 Section 16.2.1 Section 16.3.1 (1) Section 16.3.1 (3) Section 16.3.1 (5) Section 16.3.1 (6) Section 16.3.5 Section 16.3.6 Appendix. 4 Appendix. 12.1 Appendix. 12.5 (3) Appendix. 12.8 | The table is partially changed. The sentences are partially changed. The diagram is partially changed. The table is partially changed. The diagram is partially changed. The table is partially changed. The table is partially changed. The diagram is partially changed. The sentences are added. The table is deleted. The diagram is partially changed. Added. The table is partially changed. The table is partially changed. Added. Added. The contents are entirely changed. The sentences are partially changed. The sentences are partially changed. Added. |
| Aug. 2013 | SH(NA)030105ENG-E | The scale measurement function is added. 4. Additional instructions Section 1.3.1 Section 1.3.2 Section 1.4 Section 1.5 Section 1.6 Section 5.1.1 Section 5.1.3 Section 5.1.4 Section 5.2.1 Section 5.2.4 Section 5.2.6 Section 7.1.5 (4) Section 7.4 (3) Section 8.1 Section 8.2 Section 11.4.2 Section 11.4.3 Section 11.6 (1) (a) Section 11.6 (1) (b) Section 11.7 (1) Section 14.1.1 Section 14.1.2 Section 15.3.2 Chapter 17 App. 4 App. 12 | CAUTION is added. Note 10 is added. Note 10 is added. A function is added. The sentences are added. The table is changed. Note 2 is added. PA22 is added. The operation mode of PC27 is changed. PD11 is added. PA22 is added. PD11 is added. PF23 is partially changed. Table is added. The table is partially changed. The table is partially changed. The table is changed. Note 8 is added. The table is changed. Added. The table is partially changed. The table is partially changed. The table is partially changed. The illustration is partially changed. POINT is added. Added. The sentences are added. Moved to chapter 17. |
| Dec. 2013 | SH(NA)030105ENG-F | Functions are added. Descriptions of batteries are changed. Section 1.1 Section 1.3.1 Section 1.3.2 Section 1.4 Section 1.5 (2) Section 3.3.2 (1) Section 3.3.2 (2) Section 3.3.3 | Table is added. Note is added. Note is added. A function is added. Special specification is added. The sentences are changed. Note is added. POINT is added. |

| Revision Date | *Manual Number | Revision | |
|---------------|-------------------|--------------------------------------------------------------------------------------------------------------------------------------------------------------------------------------------------------------------------------------------------------------------------------------------------------------------------------------------------------------------------------------------------------------------------------------------------------------------------------------------------------------------------------------------------------------------------------------------------------------------------------------------------------------------------------------------------------------------------------------|-----------------------------------------------------------------------------------------------------------------------------------------------------------------------------------------------------------------------------------------------------------------------------------------------------------------------------------------------------------------------------------------------------------------------------------------------------------------------------------------------------------------------------------------------------------------------------------------------------------------------------------------------------------------------------------------------------------------------------------------------------------------------------------------------------------------------------------------------------------------------------------------------------------------------------------------------------------------------------------------------------------------------------------------------------------------------------------------------------------------------------------------------------------------------------------------------|
| Dec. 2013 | SH(NA)030105ENG-F | Section 3.10.1 (2) Section 3.10.2 (1) Section 4.5.2 (b) Chapter 5 Section 6.2 Section 7.1.1 (1) Section 7.1.3 Section 7.1.4 (1) Section 7.2.3 (1) Section 7.3 Section 7.3.1 Section 7.3.2 Section 7.4 Chapter 8 Section 10.5 Section 11.3 Section 11.4.2 Section 11.6 Section 11.9 (2) Section 11.11 Section 12.2 (1) Section 12.2 (2) Section 13.3.4 Section 14.4.1 Chapter 15 Section 15.1.1 Section 17.1.2 Section 17.1.3 Section 17.1.4 Section 17.1.7 Section 17.2 App. 1 App. 2 (1) App. 4.2.3 App. 4.3 App. 4.4 App. 4.6.1 App. 4.6.2 App. 4.7 App. 4.8.1 App. 4.8.2 App. 4.8.3 App. 12 | Partially changed. Partially changed. The table is partially changed. PA20, PA22, PB24, PE10, PF06, PF25, and PF31 are partially changed. POINT is added. Partially changed. POINT is added. The sentence is added. The title is changed. The sentence is added. Partially changed. Partially changed. Partially changed. POINT is added. The table is changed. Note is partially changed. POINT is added. Partially changed. Partially changed. Partially changed. Partially changed. Partially changed. Partially changed. Partially changed. POINT is changed. The table is partially changed. The sentence is added. POINT is added. The table is partially changed. Partially changed. Partially changed. Partially changed. Added. POINT is partially changed. The table is changed. Partially changed. Partially changed. Partially changed. Partially changed. Note is added. Note is added. Partially changed. Partially changed. Partially changed. Partially changed. Partially changed. Partially changed. Partially changed. Added. |
| Oct. 2014 | SH(NA)030105ENG-G | Functional addition Section 1.4 Section 1.5 Section 3.3.2 Section 3.8.1 Section 3.10.1 Section 3.10.2 Section 4.3.1 Section 5.1.2 | A function is added. Partially changed. Partially changed. Partially changed. CAUTION is changed. Partially changed. POINT is added. Partially added. |

| Revision Date | *Manual Number | Revision | |
|---------------|-------------------|--------------------------------------------------------------------------------------------------------------------------------------------------------------------------------------------------------------------------------------------------------------------------------------------------------------------------------------------------------------------------------------|-----------------------------------------------------------------------------------------------------------------------------------------------------------------------------------------------------------------------------------------------------------------------------------------------------------------------------------------------------------------------------------------------------------------------------------------------------------------------------------------------------------|
| Oct. 2014 | SH(NA)030105ENG-G | Section 5.1.3 Section 5.1.5 Section 5.2.2 Section 5.2.3 Section 5.2.5 Section 7.2.3 Section 7.2.4 Section 7.5 Chapter 8 Section 8.2 Section 8.3 Section 9.1 Section 11.3 Section 11.4.2 Section 12.2 Section 14.1.2 Section 14.3.2 Section 15.1.2 Section 15.3.2 Section 17.1.3 Section 17.1.9 Section 17.2 App. 4 | Partially added. Partially added. Partially changed. Partially added. Partially changed. Partially added. Partially changed. Partially added. Partially changed. Partially changed. Added. Partially changed. Partially added. Partially added. Partially changed. Partially changed. Partially changed. Partially added. POINT is added. Partially added. POINT is added. Partially changed. Added. Partially changed. Partially changed. |
| Apr. 2015 | SH(NA)030105ENG-H | Addition of MR-J4W2-0303B6 Chapter 1 Section 1.4 Section 3.1 Section 3.3.3 Section 3.7.1 Chapter 5 Section 5.1 Section 5.2 Section 7.3.2 Section 7.4 Section 7.5 Chapter 8 Section 11.3 Section 11.6 Chapter 12 Chapter 13 Section 13.3.3 Chapter 14 Chapter 15 Chapter 16 Chapter 17 Chapter 18 App. 13 | POINT is added. Partially added. CAUTION is added. Partially changed. Partially changed. POINT is added. Partially changed. Partially changed. POINT is added. POINT is added. POINT is added. Partially changed. Partially changed. Partially changed. POINT is added. POINT is added. POINT is added. Partially changed. POINT is added. POINT is added. POINT is added. Partially changed. Added. Added. |
| Sep. 2015 | SH(NA)030105ENG-J | The contents of the one-touch tuning are changed, and operable environment is changed to maximum altitude of 2000 m above sea level. 1. To prevent electric shock, note the following 4. Additional instructions (1) Section 1.3 Section 1.5 (2) Section 2.7 | Partially changed. Partially changed. The altitude is changed. Partially changed. Partially added. Added. |

| Revision Date | *Manual Number | Revision | |
|---------------|-------------------|---------------------------------------------------------------------------------------------------------------------------------------------------------------------------------------------------------------------------------------------------------------------------------------------------------------------------------------------------------------------------------------------------------------------------------------------------------------------------------------------------------------------------------------------------------------------------------------------------------------------------------------------------|-----------------------------------------------------------------------------------------------------------------------------------------------------------------------------------------------------------------------------------------------------------------------------------------------------------------------------------------------------------------------------------------------------------------------------------------------------------------------------------------------------------------------------------------------------------------------------------------------------------------------------------------------------------------------------------------------------------------------------------------------------------------------------------------------------------------------------------------------------------------------------------------------------------------------------------------------------------|
| Sep. 2015 | SH(NA)030105ENG-J | Section 3.2.1 Section 3.7.1 Section 5.1.6 Section 5.2.2 Section 5.2.3 Section 5.2.6 Section 7.2.3 Section 7.3.2 Section 8.2 Section 11.1.3 Section 11.3.3 Section 11.4.2 Section 11.6 (2) Section 13.1.1 Section 13.1.5 Section 13.3.1 Section 13.3.3 Section 14.3.3 Section 14.3.5 Section 15.3.3 Section 16.3.3 Section 17.1.7 Section 17.1.8 Section 17.1.9 Section 17.2 Section 18.1.6 (2) Section 18.3.1 Section 18.3.4 Section 18.3.7 Section 18.3.8 Section 18.4.1 Section 18.7.4 App. 1 App. 2 App. 4 App. 12 App. 14 | Partially changed. Partially changed. [Pr. PF18] is added. Partially changed. Partially changed. [Pr. PF18] is added. The sentences are added to [Pr. PF25]. Note is added. POINT is added. [AL. 68] is added. Partially changed. Partially changed. POINT is added. Partially changed. Partially changed. Partially changed. Partially added. Partially added. Partially added. Partially added. Partially added. Partially added. Partially added. Partially added. Partially added. Partially added. Partially added. POINT is partially changed. Partially added. Partially changed. Partially changed. Partially changed. Partially changed. Partially changed. Partially changed. Partially changed. Partially changed. Partially changed. Partially added. Partially added. Partially added. Partially added. Added. |
| May 2016 | SH(NA)030105ENG-K | Adaptive filter II is improved. 3. To prevent injury, note the following 4. Additional instructions (2), (5), (6) DISPOSAL OF WASTE Section 1.6 Section 1.6 Section 2.5 Section 3.1 Chapter 4 Section 4.1.2 Section 4.3.3 Section 4.5.2 Section 5.2.2 Section 5.2.3 | Partially changed. Partially added. Partially added. Partially added. Partially changed. Partially changed. Partially added. CAUTION is partially changed. CAUTION is partially changed. Partially changed. Partially changed. Partially changed. Partially added to PB01. Partially added to PC05. |

| Revision Date | *Manual Number | Revision | |
|---------------|-------------------|--------------------------------------------------------------------------------------------------------------------------------------------------------------------------------------------------------------------------------------------------------------------------------------------------------------------------------------------------------------------------------------------------------------------------------------------------------------------------------------------------------------------------------|---------------------------------------------------------------------------------------------------------------------------------------------------------------------------------------------------------------------------------------------------------------------------------------------------------------------------------------------------------------------------------------------------------------------------------------------------------------------------------------------------------------------------------------------------------------------------------------------------------------------------|
| May 2016 | SH(NA)030105ENG-K | Section 5.2.6 Section 6.2 Section 6.2.2 Section 6.2.3 Section 7.1.2 Section 7.2.3 Section 8.2 Section 8.3 Chapter 9 Section 10.5 Section 11.2.2 Section 11.3.4 Section 11.4 Section 11.11 Section 13.1 Section 13.3.2 Section 14.3.2 Section 17.1.3 Section 17.1.9 Section 17.2.2 Section 18.4 Section 18.7.3 App. 1 App. 4 App. 5.7.3 App. 6 App. 14 App. 15 | PF18 is partially changed. POINT is added. Partially changed. Partially changed. Partially changed. Partially changed. Partially changed. Partially changed. Partially changed. POINT is partially changed. Note is added. Partially changed. Partially changed. Partially changed. Partially changed. Partially changed. Partially changed. Note is partially changed. Partially changed. Partially changed. POINT is partially changed. Partially changed. Partially changed. Partially changed. Partially added. Partially added. Added. |
| Mar. 2017 | SH(NA)030105ENG-L | TM-RG2M series / TM-RU2M series direct drive motor is added. 4. Additional instructions (1) Transportation and installation Section 1.3.1 Section 1.3.2 Section 1.3.3 Section 3.5.1 Section 3.5.2 Section 4.1.2 Chapter 5 Section 6.2 Section 6.2.2 Section 6.2.3 Section 8.2 Section 8.3 Chapter 11 Section 11.1.1 Section 11.1.3 Section 11.2.2 Section 11.3.4 Section 11.4.2 Section 11.6 Section 11.10 Section 13.3.3 Chapter 15 Section 15.3.2 | Partially changed. Partially changed. Partially changed. Added direct drive motor. Partially changed. Partially changed. Partially changed. CAUTION is changed. POINT is added. Partially changed. Partially added. Partially changed. Partially changed. The title is changed. Partially changed. Partially changed. Partially changed. Partially changed. Partially added. Partially added. Partially changed. The diagrams are partially changed. POINT is added. Partially changed. |

| Revision Date | *Manual Number | Revision | |
|---------------|-------------------|---------------------------------------------------|-------------------------------------------------------------------------------------------------|
| Oct. 2017 | SH(NA)030105ENG-M | App. 4.2.2 App. 4.2.3 App. 4.7 App. 14.2 | Partially changed. Partially changed. CAUTION is partially changed. Partially changed. |
| | | | |

This manual confers no industrial property rights or any rights of any other kind, nor does it confer any patent licenses. Mitsubishi Electric Corporation cannot be held responsible for any problems involving industrial property rights which may occur as a result of using the contents noted in this manual.

MELSERVO is a trademark or registered trademark of Mitsubishi Electric Corporation in Japan and/or other countries.
Microsoft, Windows, Internet Explorer, and Windows Vista are registered trademarks or trademarks of Microsoft Corporation in the United States, Japan, and/or other countries.
Intel, Pentium, and Celeron are trademarks of Intel Corporation in the United States and/or other countries.
All other product names and company names are trademarks or registered trademarks of their respective companies.

Warranty

1. Warranty period and coverage

We will repair any failure or defect hereinafter referred to as "failure" in our FA equipment hereinafter referred to as the "Product" arisen during warranty period at no charge due to causes for which we are responsible through the distributor from which you purchased the Product or our service provider. However, we will charge the actual cost of dispatching our engineer for an on-site repair work on request by customer in Japan or overseas countries. We are not responsible for any on-site readjustment and/or trial run that may be required after a defective unit are repaired or replaced.

[Term]

The term of warranty for Product is twelve (12) months after your purchase or delivery of the Product to a place designated by you or eighteen (18) months from the date of manufacture whichever comes first ("Warranty Period"). Warranty period for repaired Product cannot exceed beyond the original warranty period before any repair work.

[Limitations]

- (1) You are requested to conduct an initial failure diagnosis by yourself, as a general rule.
It can also be carried out by us or our service company upon your request and the actual cost will be charged. However, it will not be charged if we are responsible for the cause of the failure.
- (2) This limited warranty applies only when the condition, method, environment, etc. of use are in compliance with the terms and conditions and instructions that are set forth in the instruction manual and user manual for the Product and the caution label affixed to the Product.
- (3) Even during the term of warranty, the repair cost will be charged on you in the following cases;
 - (i) a failure caused by your improper storing or handling, carelessness or negligence, etc., and a failure caused by your hardware or software problem
 - (ii) a failure caused by any alteration, etc. to the Product made on your side without our approval
 - (iii) a failure which may be regarded as avoidable, if your equipment in which the Product is incorporated is equipped with a safety device required by applicable laws and has any function or structure considered to be indispensable according to a common sense in the industry
 - (iv) a failure which may be regarded as avoidable if consumable parts designated in the instruction manual, etc. are duly maintained and replaced
 - (v) any replacement of consumable parts (battery, fan, smoothing capacitor, etc.)
 - (vi) a failure caused by external factors such as inevitable accidents, including without limitation fire and abnormal fluctuation of voltage, and acts of God, including without limitation earthquake, lightning and natural disasters
 - (vii) a failure generated by an unforeseeable cause with a scientific technology that was not available at the time of the shipment of the Product from our company
 - (viii) any other failures which we are not responsible for or which you acknowledge we are not responsible for

2. Term of warranty after the stop of production

- (1) We may accept the repair at charge for another seven (7) years after the production of the product is discontinued. The announcement of the stop of production for each model can be seen in our Sales and Service, etc.
- (2) Please note that the Product (including its spare parts) cannot be ordered after its stop of production.

3. Service in overseas countries

Our regional FA Center in overseas countries will accept the repair work of the Product. However, the terms and conditions of the repair work may differ depending on each FA Center. Please ask your local FA center for details.

4. Exclusion of loss in opportunity and secondary loss from warranty liability

Regardless of the gratis warranty term, Mitsubishi shall not be liable for compensation to:

- (1) Damages caused by any cause found not to be the responsibility of Mitsubishi.
- (2) Loss in opportunity, lost profits incurred to the user by Failures of Mitsubishi products.
- (3) Special damages and secondary damages whether foreseeable or not, compensation for accidents, and compensation for damages to products other than Mitsubishi products.
- (4) Replacement by the user, maintenance of on-site equipment, start-up test run and other tasks.

5. Change of Product specifications

Specifications listed in our catalogs, manuals or technical documents may be changed without notice.

6. Application and use of the Product

- (1) For the use of our General-Purpose AC Servo, its applications should be those that may not result in a serious damage even if any failure or malfunction occurs in General-Purpose AC Servo, and a backup or fail-safe function should operate on an external system to General-Purpose AC Servo when any failure or malfunction occurs.
- (2) Our General-Purpose AC Servo is designed and manufactured as a general purpose product for use at general industries. Therefore, applications substantially influential on the public interest for such as atomic power plants and other power plants of electric power companies, and also which require a special quality assurance system, including applications for railway companies and government or public offices are not recommended, and we assume no responsibility for any failure caused by these applications when used
In addition, applications which may be substantially influential to human lives or properties for such as airlines, medical treatments, railway service, incineration and fuel systems, man-operated material handling equipment, entertainment machines, safety machines, etc. are not recommended, and we assume no responsibility for any failure caused by these applications when used. We will review the acceptability of the abovementioned applications, if you agree not to require a specific quality for a specific application. Please contact us for consultation.

| | |
|------------|----------------------------|
| MODEL | MR-J4W-B INSTRUCTIONMANUAL |
| MODEL CODE | 1CW806 |

MITSUBISHI ELECTRIC CORPORATION

HEAD OFFICE: TOKYO BLDG MARUNOUCHI TOKYO 100-8310