



INVERTER

FR-A800

INSTALLATION GUIDELINE

FR-A820-00046(0.4K) to 04750(90K)(-E)

FR-A840-00023(0.4K) to 06830(280K)(-E)

FR-A842-07700(315K) to 12120(500K)(-E)

FR-A846-00023(0.4K) to 03610(132K)(-E)

Thank you for choosing this Mitsubishi Electric Inverter.
This Installation guideline and the enclosed CD-ROM give handling information and precautions for use of this product.
Do not use this product until you have a full knowledge of the equipment, the safety information and the instructions.
Please forward this Installation guideline and the CD-ROM to the end user.

CONTENTS

[1]	INSTALLATION AND INSTRUCTIONS.....	1
[2]	WIRING	4
[3]	FAILSAFE OF THE SYSTEM WHICH USES THE INVERTER.....	35
[4]	PRECAUTIONS FOR USE OF THE INVERTER	36
[5]	BASIC OPERATION	38
[6]	TROUBLESHOOTING	59
[7]	SPECIFICATIONS	62
[A]	APPENDIX	68



Art. No.: 274662
31052017
Version G

Version check

Print date		Art. no.	Revision
11/2013	pdp	274662-A	First edition
04/2014	akl	274662-B	Addition: FR-A840-03250(110K) to 06830(280K) Changes: Parameter list, Setting values, Protective functions
06/2014	akl	274662-C	Changes: <ul style="list-style-type: none"> • Inverter type: rating and capacity plate • Parameter list, Protective functions
08/2014	akl	274662-D	Additions: <ul style="list-style-type: none"> • FR-A842-07700(315K) to 12120 (500K) (Separated converter type) • FR-A846-00023(0.4K) to 00470(18.5K) (IP55 compatible model)
05/2016	akl	274662-F *1	Additions: FR-A846-00620(22K) to 03610(132K) (IP55 compatible model) Changes: Parameter list, Setting values, Alarm displays, Safety stop function description
05/2017	akl	274662-G	Additions: <ul style="list-style-type: none"> • FR-A800-GF (CC-Link IE Field Network communication function built-in type) • FR-A800-E (Ethernet communication function built-in type) Changes: Safety stop function description

*1 Version F comprises update to version E of the Japanese original manual.

For Maximum Safety

- Mitsubishi Electric transistorized inverters are not designed or manufactured to be used in equipment or systems in situations that can affect or endanger human life.
- When considering this product for operation in special applications such as machinery or systems used in passenger transportation, medical, aerospace, atomic power, electric power, or submarine repeating applications, please contact your nearest Mitsubishi Electric sales representative.
- Although this product was manufactured under conditions of strict quality control, you are strongly advised to install safety devices to prevent serious accidents when it is used in facilities where breakdowns of the product are likely to cause a serious accident.
- Please check upon receiving of the inverter whether this instruction manual corresponds to the delivered inverter. Compare the specifications on the capacity plate with the specifications given in this manual.

This section is specifically about safety matters

Do not attempt to install, operate, maintain or inspect the inverter until you have read through this Installation Guideline and appended documents carefully and can use the equipment correctly. Do not use the inverter until you have a full knowledge of the equipment, safety information and instructions.

Installation, operation, maintenance and inspection must be performed by qualified personnel. Here, qualified personnel means personnel who meets all the conditions below.

- A person who took a proper engineering training. Please note if you can take a proper engineering training at your local Mitsubishi Electric office. Such training may be available at your local Mitsubishi Electric office. Contact your local sales office for schedules and locations.
- A person who can access operating manuals for the protective devices (e.g. light curtain) connected to the safety control system.

A person who has read and familiarized himself/herself with the manuals.

In this Installation Guideline, the safety instruction levels are classified into "WARNING" and "CAUTION".

WARNING

Assumes that incorrect handling may cause hazardous conditions, resulting in death or severe injury.

CAUTION

Assumes that incorrect handling may cause hazardous conditions, resulting in medium or slight injury, or may cause physical damage only.

Note that even the  **CAUTION** level may lead to a serious consequence according to conditions. Please follow strictly the instructions of both levels because they are important to personnel safety.

Electric Shock Prevention

WARNING

- While power is on or when the inverter is running, do not open the front cover. Otherwise you may get an electric shock.
- Do not run the inverter with the front cover removed. Otherwise, you may access the exposed high-voltage terminals or the charging part of the circuitry and get an electric shock.
- Even if power is off, do not remove the front cover except for wiring or periodic inspection. You may access the charged inverter circuits and get an electric shock.
- Before starting wiring or inspection, check to make sure that the operation panel indicator is off, wait for at least 10 minutes after the power supply has been switched off, and check that there are no residual voltage using a tester or the like. The capacitor is charged with high voltage for some time after power off and it is dangerous.
- This inverter must be earthed. Earthing must conform to the requirements of national and local safety regulations and electrical codes (JIS, NEC section 250, IEC 536 class 1 and other applicable standards). A neutral-point earthed power supply for 400V class inverter in compliance with EN standard must be used.
- Any person who is involved in the wiring or inspection of this equipment should be fully competent to do the work.
- Always install the inverter before wiring. Otherwise, you may get an electric shock or be injured.
- If your application requires by installation standards an RCD (residual current device) as up stream protection please select according to DIN VDE 0100-530 as following:
Single phase inverter type A or B
Three phase inverter only type B
(Additional instructions on the use of a residual current device are contained on *page 70*.)
- Perform setting dial and key operations with dry hands to prevent an electric shock. Otherwise you may get an electric shock.
- Do not subject the cables to scratches, excessive stress, heavy loads or pinching. Otherwise you may get an electric shock.
- Do not replace the cooling fan while power is on. It is dangerous to replace the cooling fan while power is on.
- Do not touch the printed circuit board or handle the cables with wet hands. You may get an electric shock.
- Standard models and IP55 compatible models only: When measuring the main circuit capacitor capacity, the DC voltage is applied to the motor for 1s at powering OFF. Never touch the motor terminal, etc. right after powering OFF to prevent an electric shock.
- A PM motor is a synchronous motor with high-performance magnets embedded in the rotor. Motor terminals holds high-voltage while the motor is running even after the inverter power is turned OFF. Before wiring or inspection, the motor must be confirmed to be stopped. In an application, such as fan and blower, where the motor is driven by the load, a low-voltage manual motor starter must be connected at the inverter's output side, and wiring and inspection must be performed while the motor starter is open. Otherwise you may get an electric shock.

Fire Prevention

CAUTION

- Mount the inverter to incombustible material. Install the inverter on a nonflammable wall without holes (so that nobody can touch the inverter heatsink on the rear side, etc.). Mounting it to or near combustible material can cause a fire.
- If the inverter has become faulty, switch off the inverter power. A continuous flow of large current could cause a fire.
- When using a brake resistor, a sequence that will turn OFF power when a fault signal is output must be configured. Otherwise the brake resistor may excessively overheat due to damage of the brake transistor and such, causing a fire.
- Do not connect a resistor directly to the DC terminals P/+, N/-. This could cause a fire and destroy the inverter. The surface temperature of braking resistors can far exceed 100 °C for brief periods. Make sure that there is adequate protection against accidental contact and a safe distance is maintained to other units and system parts.
- Resistors cannot be used for FR-A842 (separated converter type) and FR-A846 (IP55 compatible models).
- Be sure to perform daily and periodic inspections as specified in the Instruction Manual. If a product is used without any inspection, a burst, breakage, or a fire may occur.

Injury Prevention

⚠ CAUTION

- Apply only the voltage specified in the instruction manual to each terminal. Otherwise, burst, damage, etc. may occur.
- Ensure that the cables are connected to the correct terminals. Otherwise, burst, damage, etc. may occur.
- Always make sure that polarity is correct to prevent damage, etc. Otherwise, burst, damage, etc. may occur.
- While power is on or for some time after power-off, do not touch the inverter as it is hot and you may get burnt.

Additional Instructions

The following instructions must be also followed. If the product is handled incorrectly, it may cause unexpected fault, an injury, or an electric shock.

Transportation and installation

⚠ CAUTION

- Any person who is opening a package using a sharp object, such as a knife and cutter, must wear gloves to prevent injuries caused by the edge of the sharp object.
- When carrying products, use correct lifting gear to prevent injury.
- Do not stand or rest heavy objects on the product.
- Do not stack the inverter boxes higher than the number recommended.
- When carrying the inverter, do not hold it by the front cover or setting dial; it may fall off or fail.
- During installation, caution must be taken not to drop the inverter as doing so may cause injuries.
- Ensure that installation position and material can withstand the weight of the inverter. Install according to the information in the instruction manual.
- Do not install the product on a hot surface.
- Check the inverter mounting orientation is correct.
- The inverter must be installed on a strong surface securely with screws so that it will not drop.
- Do not install or operate the inverter if it is damaged or has parts missing. This can result in breakdowns.
- Prevent other conductive bodies such as screws and metal fragments or other flammable substance such as oil from entering the inverter.
- As the inverter is a precision instrument, do not drop or subject it to impact.
- Use the inverter under the following environmental conditions. Otherwise, the inverter may be damaged.

Operating condition	FR-A820/A840/A842	FR-A846 (IP55 compatible models)
Surrounding air temperature	LD, ND (initial setting), HD ratings: -10°C to $+50^{\circ}\text{C}$ ^{*1} (non-freezing) SLD rating: -10°C to $+40^{\circ}\text{C}$ ^{*2} (non-freezing)	-10°C to $+40^{\circ}\text{C}$ (non-freezing)
Ambient humidity	With circuit board coating (conforming to IEC 60721-3-3 3C2/3S2): 95% RH or less (non-condensing), Without circuit board coating: 90% RH or less (non-condensing)	95% RH or less (non-condensing)
Storage temperature	-20°C to $+65^{\circ}\text{C}$ ^{*3}	
Atmosphere	Indoors (free from corrosive gas, flammable gas, oil mist, dust and dirt)	
Altitude	Maximum 1000 m above sea level for standard operation. After that derate by 3% for every extra 500 m up to 2500 m (91%).	
Vibration	5.9 m/s ² or less ^{*4} at 10 to 55 Hz (directions of X, Y, Z axes)	

^{*1} 0 to $+50^{\circ}\text{C}$ for the FR-A800-GF.

^{*2} 0 to $+40^{\circ}\text{C}$ for the FR-A800-GF.

^{*3} Temperature applicable for a short time, e.g. in transit.

^{*4} 2.9 m/s² or less for the FR-A840-04320(160K) or higher, and the FR-A846-01800(55K) or higher.

- If halogen-based materials (fluorine, chlorine, bromine, iodine, etc.) infiltrate into a Mitsubishi Electric product, the product will be damaged. Halogen-based materials are often included in fumigant, which is used to sterilize or disinfect wooden packages. When packaging, prevent residual fumigant components from being infiltrated into Mitsubishi Electric products, or use an alternative sterilization or disinfection method (heat disinfection, etc.) for packaging. Sterilization or disinfection of wooden package should also be performed before packaging the product.
- To prevent a failure, do not use the inverter with a part or material containing halogen flame retardant including bromine.

Wiring

⚠ CAUTION

- Do not install assemblies or components (e. g. power factor correction capacitors) on the inverter output side, which are not approved from Mitsubishi Electric. These devices on the inverter output side may be overheated or burn out.
- The direction of rotation of the motor corresponds to the direction of rotation commands (STF/STR) only if the phase sequence (U, V, W) is maintained.
- PM motor terminals (U, V, W) hold high-voltage while the PM motor is running even after the power is turned OFF. Before wiring, the PM motor must be confirmed to be stopped. Otherwise you may get an electric shock.
- Never connect a PM motor to the commercial power supply.
Applying the commercial power supply to input terminals (U, V, W) of a PM motor will burn the PM motor. The PM motor must be connected with the output terminals (U, V, W) of the inverter.

Test operation and adjustment

CAUTION

- Before starting operation, confirm and adjust the parameters. A failure to do so may cause some machines to make unexpected motions.

Operation

WARNING

- When you have chosen the retry function, stay away from the equipment as it will restart suddenly after an alarm stop.
- Since pressing the  key may not stop output depending on the function setting status, provide a circuit and switch separately to make an emergency stop (power off, mechanical brake operation for emergency stop, etc).
- Make sure that the start signal is off before resetting the inverter alarm. A failure to do so may restart the motor suddenly.
- Do not use a PM motor for an application where the PM motor is driven by its load and runs at a speed higher than the maximum motor speed.
- Performing pre-excitation (LX signal and X13 signal) under torque control (Real sensorless vector control) may start the motor running at a low speed even when the start command (STF or STR) is not input. The motor may run also at a low speed when the speed limit value = 0 with a start command input. It must be confirmed that the motor running will not cause any safety problem before performing pre-excitation.
- The inverter can be started and stopped via the serial port communications link or the field bus. However, please note that depending on the settings of the communications parameters it may not be possible to stop the system via these connections if there is an error in the communications system or the data line. In configurations like this it is thus essential to install additional safety hardware that makes it possible to stop the system in an emergency (e.g. controller inhibit via control signal, external motor contactor etc). Clear and unambiguous warnings about this must be posted on site for the operating and service staff.
- Use this inverter only with three-phase induction motors or with a PM motor. Connection of any other electrical equipment to the inverter output may damage the inverter as well as the equipment.
- Do not modify the equipment.
- Do not perform parts removal which is not instructed in this manual. Doing so may lead to fault or damage of the inverter.

CAUTION

- The electronic thermal relay function does not guarantee protection of the motor from overheating. It is recommended to install both an external thermal and PTC thermistor for overheat protection.
- Do not use a magnetic contactor on the inverter input for frequent starting/stopping of the inverter. Otherwise, the life of the inverter decreases.
- Use a noise filter to reduce the effect of electromagnetic interference and follow the accepted EMC procedures for proper installation of frequency inverters. Otherwise nearby electronic equipment may be affected.
- Take appropriate measures regarding harmonics. Otherwise this can endanger compensation systems or overload generators.
- When driving a 400V class motor by the inverter, the motor must be an insulation-enhanced motor or measures must be taken to suppress surge voltage. Surge voltage attributable to the wiring constants may occur at the motor terminals, deteriorating the insulation of the motor.
- Use a motor designed for inverter operation. (The stress for motor windings is bigger than in line power supply).
- When parameter clear or all clear is performed, set again the required parameters before starting operations. Each parameter returns to the initial value.
- The inverter can be easily set for high-speed operation. Before changing its setting, fully examine the performances of the motor and machine.
- The DC braking function of the frequency inverter is not designed to continuously hold a load. Use an electro-mechanical holding brake on the motor for this purpose.
- Before running an inverter which had been stored for a long period, always perform inspection and test operation.
- For prevention of damage due to static electricity, touch nearby metal before touching this product to eliminate static electricity from your body.
- Only one PM motor can be connected to an inverter.
- A PM motor must be used under PM sensorless vector control. When operating with PM sensorless vector control, a synchronous motor, induction motor or synchronous induction motor may only be used when it is a PM motor.
- Do not connect a PM motor in the induction motor control settings (initial settings). Do not use an induction motor in the PM sensorless vector control settings. It will cause a failure.
- In the system with a PM motor, the inverter power must be turned ON before closing the contacts of the contactor at the output side.
- In order to protect the inverter and the system against unauthorized access by external systems via network, take security measures including firewall settings.
- Depending on the network environment, the inverter may not operate as intended due to delays or disconnection in communication. Carefully consider the conditions and safety for the inverter on site.

Emergency stop

CAUTION

- Provide a safety backup such as an emergency brake which will prevent the machine and equipment from hazardous conditions if the inverter fails.
- When the breaker on the inverter primary side trips, check for the wiring fault (short circuit), damage to internal parts of the inverter, etc. Identify the cause of the trip, then remove the cause and power on the breaker.
- When the protective function is activated (i. e. the frequency inverter switches off with an error message), take the corresponding corrective action as described in the inverter manual, then reset the inverter, and resume operation.

Maintenance, inspection and parts replacement

CAUTION

- Do not carry out a megger (insulation resistance) test on the control circuit of the inverter. It will cause a failure.

Disposing of the inverter

CAUTION

- Treat as industrial waste.

General instructions

Many of the diagrams and drawings in instruction manuals show the inverter without a cover, or partially open. Never run the inverter in this status. Always replace the cover and follow instruction manuals when operating the inverter. For more details on the PM motor, refer to the Instruction Manual of the PM motor.

For IP55 compatible models: Waterproof and dustproof performances

CAUTION

- The inverter is rated with an IPX5 ^{*1} waterproof rating and an IP5X ^{*2} dustproof rating when the operation panel (FR-DU08-01), the front cover, the wiring cover, and the cable glands are securely fixed with screws.
- The items enclosed with the inverter such as the Instruction Manual or CD are not rated with the IPX5 waterproof or IP5X dustproof ratings.
- Although the inverter is rated with the IPX5 waterproof and IP5X dustproof ratings, it is not intended for use in water. Also, the ratings do not guarantee protection of the inverter from needless submersion in water or being washed under strong running water such as a shower.
- Do not pour or apply the following liquids over the inverter: water containing soap, detergent, or bath additives; sea water; swimming pool water; warm water; boiling water; etc.
- The inverter is intended for indoor ^{*3} installation and not for outdoor installation. Avoid places where the inverter is subjected to direct sunlight, rain, sleet, snow, or freezing temperatures.
- If the operation panel (FR-DU08-01) is not installed, if the screws of the operation panel are not tightened, or if the operation panel is damaged or deformed, the IPX5 waterproof performance and the IP5X dustproof performance are impaired. If any abnormalities are found on the operation panel, ask for an inspection and repair.
- If the screws of the front cover or the wiring cover are not tightened, if any foreign matter (hair, sand grain, fiber, etc.) is stuck between the inverter and the gasket, if the gasket is damaged, or if the front cover or the wiring cover is damaged or deformed, the IPX5 waterproof performance and the IP5X dustproof performance are impaired. If any abnormalities are found on the front cover, wiring cover, or the gasket of the inverter, ask for an inspection and repair.
- Cable glands are important components to maintain the waterproof and dustproof performances. Be sure to use cable glands of the recommended size and shape or equivalent. The standard protective bushes cannot sufficiently maintain the IPX5 waterproof performance and the IP5X dustproof performance.
- If a cable gland is damaged or deformed, the IPX5 waterproof performance and the IP5X dustproof performance are impaired. If any abnormalities are found on the cable glands, ask the manufacturer of the cable glands for an inspection and repair.
- To maintain the waterproof and dustproof performances of the inverter, daily and periodic inspections are recommended regardless of the presence or absence of abnormalities.

^{*1} IPX5 refers to protection of the inverter functions against water jets from any direction when about 12.5-liter water (water here refers to fresh water at room temperature (5 to 35°C)) is injected from a nozzle with an inside diameter of 6.3 mm from the distance of about 3 m for at least 3 minutes.

^{*2} IP5X refers to protection of the inverter functions and maintenance of safety when the inverter is put into a stirring device containing dust of 75 µm or smaller in diameter, stirred for 8 hours, and then removed from the device.

^{*3} Indoor here refers to the environments that are not affected by climate conditions.

1 INSTALLATION AND INSTRUCTIONS

1.1 Inverter Type

Symbol	Voltage class	Symbol	Structure, functionality	Symbol	Description	Symbol	Type *1	Communication type	Symbol	Circuit board coating *3	Plated conductor
2	200 V class	0	Standard model	00023 to 12120	Inverter SLD rated current [A]	-1	FM	Standard	Without	Without	Without
4	400 V class	2	Separated converter type	0.4 to 500K	Inverter ND rated capacity [kW]	E1		Ethernet *2	-60	With	Without
		6	IP55 compatible model			-2	CA	Standard	-06 *4	With	With
						E2		Ethernet *2			

FR - A840 - 00023 -2 -60

Symbol	Functionality
Without	Standard model
GF *5	With built-in CC-link IE Field Network function
C2	Built-in C2 filter *6
C3	Built-in C3 filter *6

Capacity plate

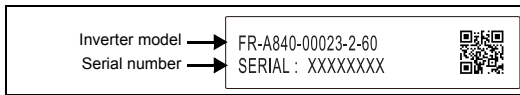

Rating plate

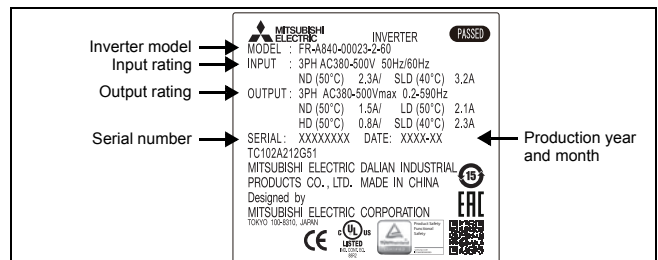

*1 Specification differs by the type. Major differences are shown in the table below:

Type	Monitor output	Initial setting			
		Built-in EMC filter	Control logic	Rated frequency	Pr. 19 "Base frequency voltage"
FM (terminal FM equipped model)	Terminal FM: pulse train output Terminal AM: analog voltage output (0 to ±10 V DC)	OFF	Sink logic	60 Hz	9999 (same as the power supply voltage)
CA (terminal CA equipped model)	Terminal CA: analog current output (0 to 20 mA DC) Terminal AM: analog voltage output (0 to ±10 V DC)	ON	Source logic	50 Hz	8888 (95% of the power supply voltage)

*2 Model with built-in Ethernet board (FR-A8ETH).

*3 Conforming to IEC60721-3-3 3C2/3S2.

*4 For the FR-A820-00340(5.5K) or higher, and the FR-A840-00170(5.5K) or higher

*5 The model with the symbol GF is not available in Europe. You can get the same functionality of this model by installing the option FR-A8NCE (Art. no. 273102).

*6 EMC Filter (IP55 compatible models only)

Notes

- The rating plate shows the inverter rated current in SLD operation (Super Light Duty). The overload current rating at SLD is 110 % of the rated current for 60 s and 120 % for 3 s at surrounding air temperature of max. 40 °C.
- The inverter model name used in this installation guide consists of the inverter model, e. g. FR-A840-00023-2-60 and the applicable motor capacity in brackets specified in [kW]. This approach helps for better understanding and for choosing the right motor. For further specification details like capacity, current or overload current rating refer to chapter 7.
- In this installation guideline the following common designations are used for the different types of inverter models:
 - FR-A8□0: Standard model
 - FR-A8□2: Separated converter type
 - FR-A8□6: IP55 compatible model
 - FR-A8□□-GF: Model with built-in CC-Link IE Field Network communication function
 - FR-A8□□-E: Model with built-in Ethernet board (FR-A8ETH)
- For selecting the right frequency inverter you should know details of your application and especially the load characteristic.



1.2 Installation of the inverter

- Install the inverter on a strong surface securely with bolts.

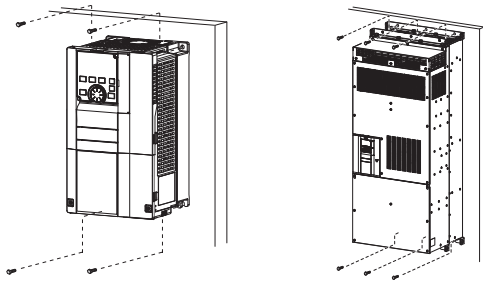

Fix six positions for the FR-A840-04320(160K) or higher and for the FR-A842 models (separated converter type).

- Leave enough clearances and take cooling measures.
- Avoid places where the inverter is subjected to direct sunlight, high temperature and high humidity.
- Install the inverter on a nonflammable surface.
- When encasing multiple inverters, install them in parallel as a cooling measure.

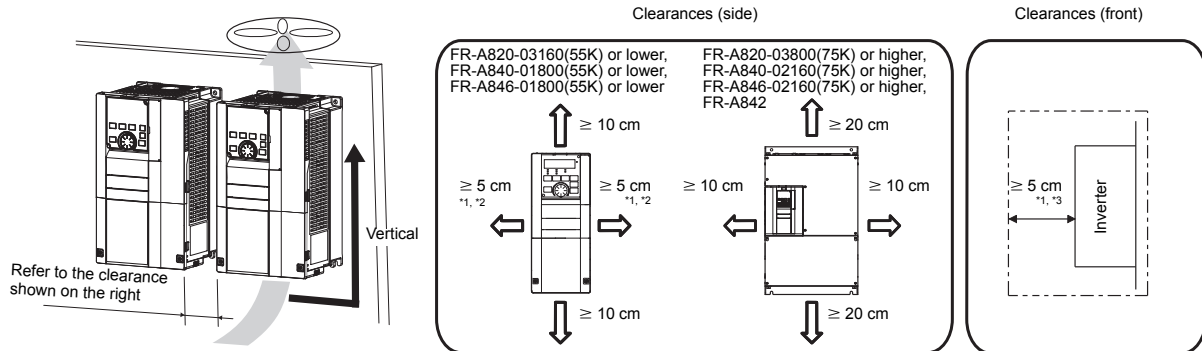

- ^{*1} For the FR-A820-00250(3.7K) or lower, the FR-A840-00126(3.7K) or lower, and the FR-A846-00126(3.7K) or lower allow 1 cm or more clearance.
- ^{*2} When using the FR-A820-01250(22K) or lower and FR-A840-00620(22K) or lower at the surrounding air temperature of 40°C or less (30°C or less for the SLD rated inverter), side-by-side installation (0 cm clearance) is available.
- ^{*3} For replacing the cooling fan of the FR-A840-04320(160K) or higher, and of the FR-A842 models, 30 cm of space is necessary in front of the inverter. Refer to the Instruction Manual for fan replacement.

1.3 Environment

Before installation, check that the environment meets following specifications:

Surrounding air temperature ^{*8,*9}	LD, ND (initial setting), HD ratings: -10°C to +50°C ^{*4} (non-freezing)	Enclosure
	SLD rating: -10°C to +40°C ^{*5} (non-freezing)	
	IP55 compatible models: -10°C to +40°C (non-freezing)	
Ambient humidity	With circuit board coating (conforming to IEC 60721-3-3 3C2/3S2), IP55 compatible models: 95% RH or less (non-condensing), Without circuit board coating: 90% RH or less (non-condensing)	
Storage temperature	-20°C to +65°C ^{*6}	
Atmosphere	Indoors (No corrosive and flammable gases, oil mist, dust and dirt)	
Altitude	Maximum 2,500 m above sea level ^{*7}	
Vibration	5.9 m/s ² or less ^{*10} at 10 to 55 Hz (directions of X, Y, Z axes)	

- ^{*4} 0 to +50 °C for the FR-A800-GF.
- ^{*5} 0 to +40 °C for the FR-A800-GF.
- ^{*6} Temperature applicable for a short time, e.g. in transit.
- ^{*7} For the installation at an altitude above 1,000 m up to 2,500 m, derate the rated current 3% per 500 m.
- ^{*8} Surrounding air temperature is a temperature measured at a measurement position in an enclosure. Ambient temperature is a temperature outside an enclosure.
- ^{*9} For the amount of heat generated by the inverter unit, refer to the Technical News (MF-Z-116) contained in the enclosed CD-ROM.
- ^{*10} 2.9 m/s² or less for the FR-A840-04320(160K) or higher, and the FR-A846-01800(55K) or higher

1.4 Accessory

- Fan cover fixing screws

These screws are necessary for compliance with the EU Directives (refer to *page 68*).

Capacity	Screw size (mm)	Quantity
FR-A820-00105(1.5K) to FR-A820-00250(3.7K) FR-A840-00083(2.2K), FR-A840-00126(3.7K)	M3 × 35	1
FR-A820-00340(5.5K) to FR-A820-00490(7.5K) FR-A840-00170(5.5K) to FR-A840-00250(7.5K)	M3 × 35	2
FR-A820-00630(11K) to FR-A820-01250(22K) FR-A840-00310(11K), FR-A840-00620(22K)	M4 × 40	2

- Eyebolt for hanging the inverter

Capacity	Eyebolt size	Quantity
FR-A840-04320(160K) to FR-A840-06830(280K)	M12	2



- Earthing (grounding) cable (1): For connection with a communication option
- CD-ROM (1): Including the Instruction Manual (Detailed) and other documents

1.5 Installing a communication option (FR-A800-E)

To use a communication option, the enclosed earthing (grounding) cable needs to be installed. Install the cable according to the following procedure:

- ① Insert spacers into the mounting holes that will not be tightened with the option mounting screws.
- ② Fit the connector of the communication option to the guide of the connector of the inverter, and insert the option as far as it goes. (Insert it to the inverter option connector 1.)
- ③ Remove the mounting screw (lower) of the Ethernet board earth plate. Fit the one terminal of the earthing (grounding) cable on the Ethernet board earth plate and fix it securely to the inverter with the mounting screw (tightening torque 0.33 Nm to 0.40 Nm).
- ④ Fix the left part of the communication option securely with the option mounting screw, and place another terminal of the earthing (grounding) cable on the right part of the option and fix the cable terminal and the option with the option mounting screw (tightening torque 0.33 Nm to 0.40 Nm).

If the screws are not tightened properly, the connector may not be inserted deep enough. Check the connector.

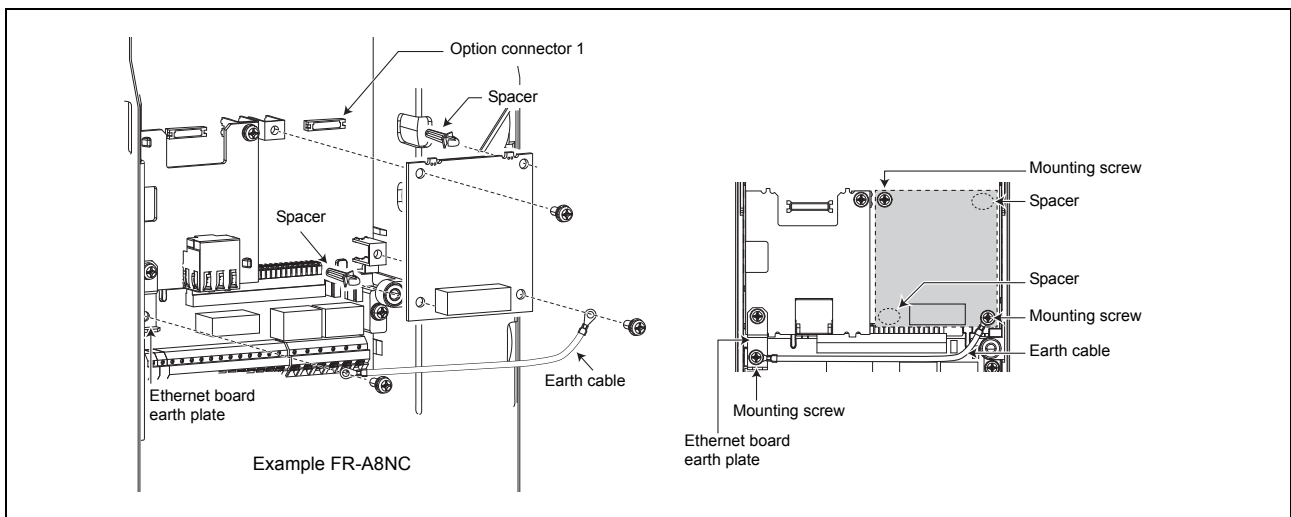

Notes

- The number and shape of the spacers used differ depending on the communication option type. Refer to the Instruction Manual of each communication option for details.
- The earth plate enclosed with a communication option is not used.

2 WIRING

2.1 Terminal connection diagrams

2.1.1 FR-A820/A840(-E)

● CA type

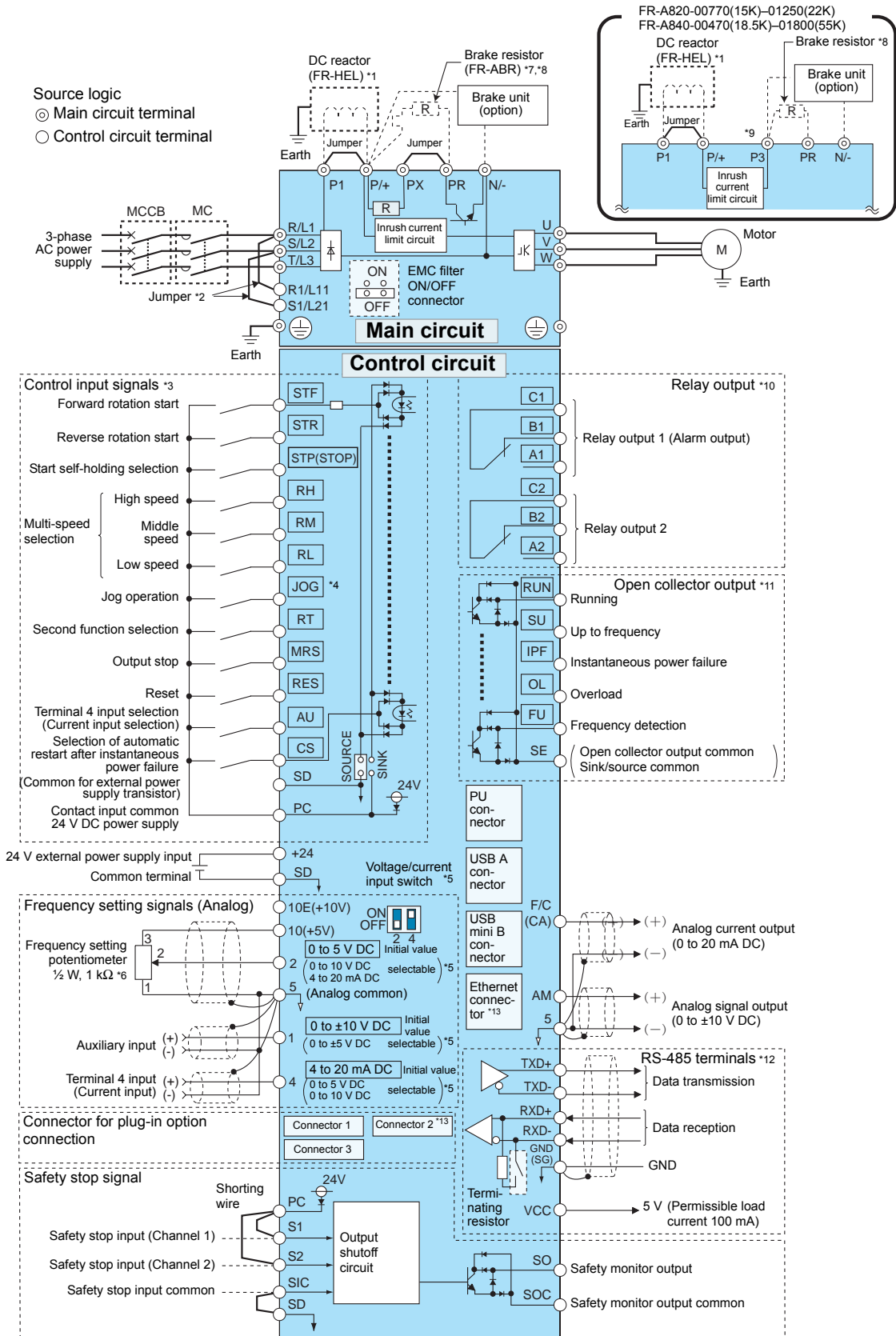

For footnotes *1 to *13 refer to next page.

- *1 For the FR-A820-03800(75K) or higher, and the FR-A840-02160(75K) or higher, or if using a motor with a capacity of 75 kW or higher, always connect a DC reactor (FR-HEL), which is available as an option.
(When selecting a DC reactor, refer to *page 62*, and select one suitable for the applicable motor capacity.) When a DC reactor is connected to the FR-A820-03160(55K) or lower or the FR-A840-01800(55K) or lower, if a jumper is installed across the terminals P1 and P/+, remove the jumper before installing the DC reactor.
- *2 When using separate power supply for the control circuit, remove the jumper between R1/L11 and S1/L21.
- *3 No input voltage is allowed for these terminals. The function of these terminals can be changed with the input terminal assignment (Pr. 178 to Pr. 189). (Refer to *page 40*.)
- *4 Terminal JOG is also used as the pulse train input terminal. Use Pr. 291 to choose JOG or pulse.
- *5 Terminal input specifications can be changed by analog input specification switchover (Pr. 73, Pr. 267). To input a voltage, set the voltage/current input switch OFF. To input a current, set the voltage/current input switch ON. Terminals 10 and 2 are also used as a PTC input terminal. (Pr. 561) (Refer to the FR-A800 Instruction Manual.)
- *6 It is recommended to use 2 W, 1 k Ω when the frequency setting signal is changed frequently.
- *7 If connecting a brake resistor, remove the jumper between PR and PX (FR-A820-00046(0.4K) to 00490(7.5K), FR-A840-00023(0.4K) to 00250(7.5K)).
- *8 Connect a brake resistor across terminals P/+ (P3) and PR. The terminal PR is equipped in FR-A820-00046(0.4K) to 01250(22K), FR-A840-00023(0.4K) to 00620(22K). Install a thermal relay to prevent overheating and damage of discharging resistors. (Refer to the FR-A800 Instruction Manual.)
- *9 Do not connect the DC power supply (under DC feeding mode) to terminal P3.
- *10 The function of these terminals can be changed with the output terminal assignment (Pr. 195, Pr. 196). (Refer to *page 40*.)
- *11 The function of these terminals can be changed with the output terminal assignment (Pr. 190 to Pr. 194). (Refer to *page 40*.)
- *12 Upon delivery the FR-A800-E inverter models are not equipped with the RS-485 terminal block.
- *13 For FR-A800-E: The option connector 2 cannot be used because the Ethernet board is installed in the initial status. The Ethernet board must be removed to install a plug-in option to the option connector 2. (However, Ethernet communication is disabled in that case.)

CAUTION

- To prevent a malfunction due to noise, keep the signal cables more than 10 cm away from the power cables. Also, separate the main circuit cables at the input side from the main circuit cables at the output side.
 - After wiring, wire offcuts must not be left in the inverter.
Wire offcuts can cause an alarm, failure or malfunction. Always keep the inverter clean.
When drilling mounting holes in a control box etc., take care not to allow chips and other foreign matter to enter the inverter.
 - Set the voltage/current input switch in the correct position. An incorrect setting may cause a fault, failure or malfunction.
-



● FM type

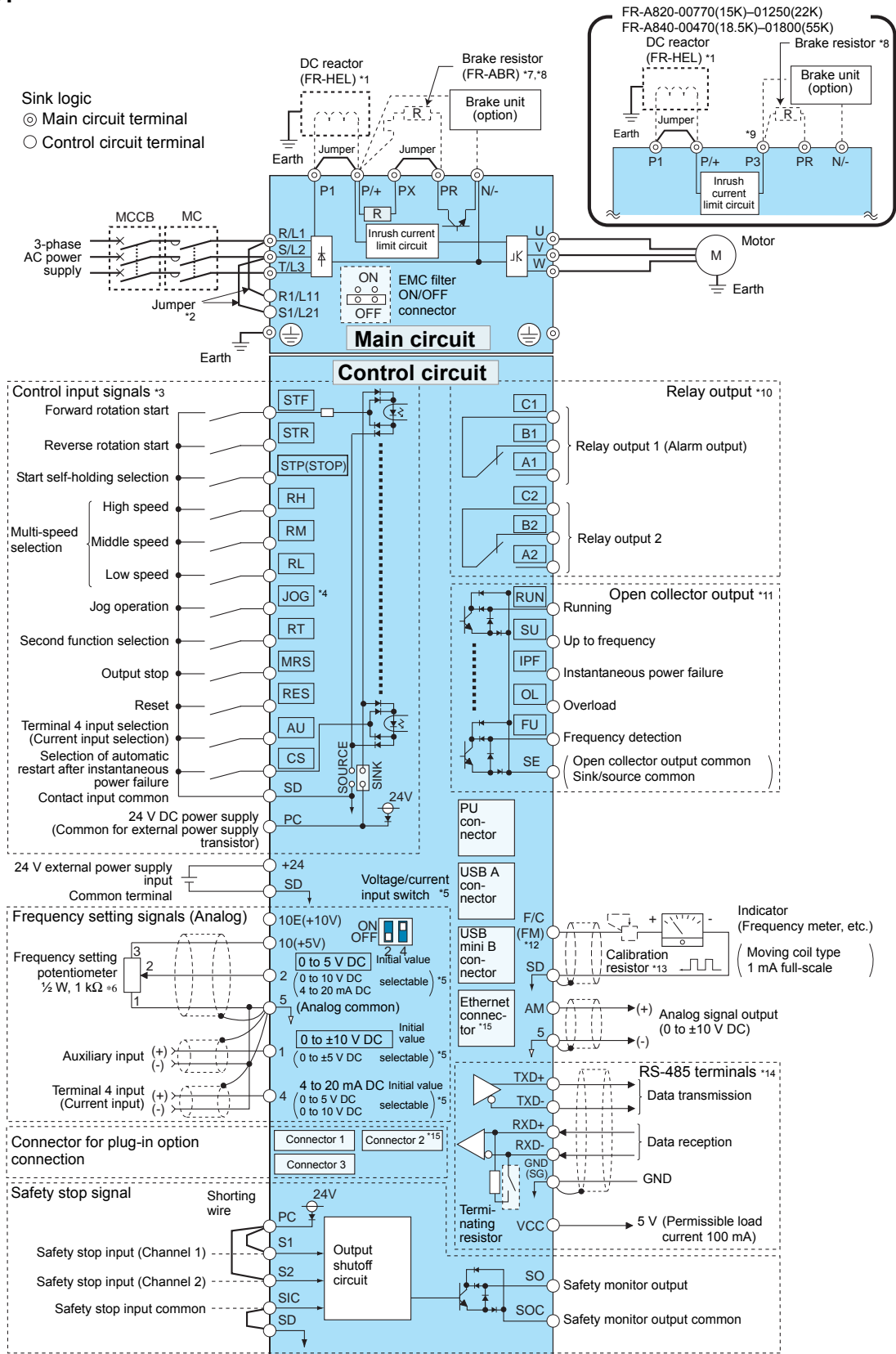

For footnotes *1 to *15 refer to next page.

- *1 For the FR-A820-03800(75K) or higher, and the FR-A840-02160(75K) or higher, or if using a motor with a capacity of 75 kW or higher, always connect a DC reactor (FR-HEL), which is available as an option.
(When selecting a DC reactor, refer to *page 62*, and select one suitable for the applicable motor capacity.) When a DC reactor is connected to the FR-A820-03160(55K) or lower or the FR-A840-01800(55K) or lower, if a jumper is installed across the terminals P1 and P/+, remove the jumper before installing the DC reactor.
- *2 When using separate power supply for the control circuit, remove the jumper between R1/L11 and S1/L21.
- *3 No input voltage is allowed for these terminals. The function of these terminals can be changed with the input terminal assignment (Pr. 178 to Pr. 189). (Refer to *page 40*.)
- *4 Terminal JOG is also used as the pulse train input terminal. Use Pr. 291 to choose JOG or pulse.
- *5 Terminal input specifications can be changed by analog input specification switchover (Pr. 73, Pr. 267). To input a voltage, set the voltage/current input switch OFF. To input a current, set the voltage/current input switch ON. Terminals 10 and 2 are also used as a PTC input terminal. (Pr. 561) (Refer to the FR-A800 Instruction Manual.)
- *6 It is recommended to use 2 W, 1 k Ω when the frequency setting signal is changed frequently.
- *7 If connecting a brake resistor, remove the jumper between PR and PX (FR-A820-00046(0.4K) to 00490(7.5K), FR-A840-00023(0.4K) to 00250(7.5K)).
- *8 Connect a brake resistor across terminals P/+ (P3) and PR. The terminal PR is equipped in FR-A820-00046(0.4K) to 01250(22K), and FR-A840-00023(0.4K) to 00620(22K). Install a thermal relay to prevent overheating and damage of discharging resistors. (Refer to the FR-A800 Instruction Manual.)
- *9 Do not connect the DC power supply (under DC feeding mode) to terminal P3.
- *10 The function of these terminals can be changed with the output terminal assignment (Pr. 195, Pr. 196). (Refer to *page 40*.)
- *11 The function of these terminals can be changed with the output terminal assignment (Pr. 190 to Pr. 194). (Refer to *page 40*.)
- *12 The terminal F/C(FM) can be used to output pulse trains as open collector output by setting Pr. 291.
- *13 Not required when calibrating the scale with the operation panel.
- *14 Upon delivery the FR-A800-E inverter models are not equipped with the RS-485 terminal block.
- *15 For FR-A800-E: The option connector 2 cannot be used because the Ethernet board is installed in the initial status. The Ethernet board must be removed to install a plug-in option to the option connector 2. (However, Ethernet communication is disabled in that case.)

CAUTION

- To prevent a malfunction due to noise, keep the signal cables more than 10 cm away from the power cables. Also, separate the main circuit cables at the input side from the main circuit cables at the output side.
 - After wiring, wire offcuts must not be left in the inverter.
Wire offcuts can cause an alarm, failure or malfunction. Always keep the inverter clean.
When drilling mounting holes in a control box etc., take care not to allow chips and other foreign matter to enter the inverter.
 - Set the voltage/current input switch in the correct position. An incorrect setting may cause a fault, failure or malfunction.
-



2.1.2 FR-A820/A840-GF

● CA type

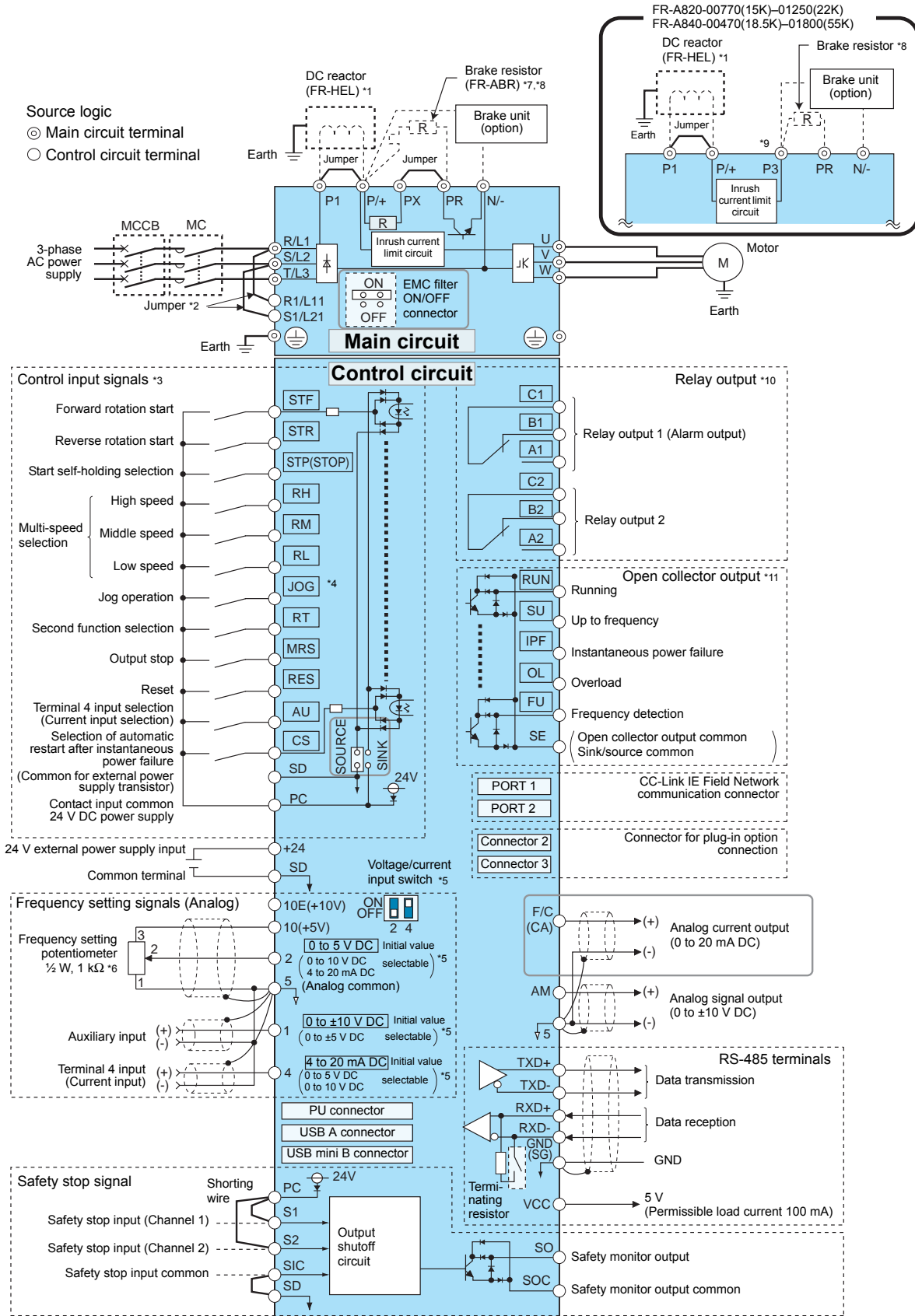

For footnotes *1 to *11 refer to next page.

Note

The model with the symbol GF is not available in Europe. You can get the same functionality of this model by installing the option FR-A8NCE (Art. no. 273102).

- *1 For the FR-A820-03800(75K) or higher, and the FR-A840-02160(75K) or higher, or if using a motor with a capacity of 75 kW or higher, always connect a DC reactor (FR-HEL), which is available as an option.
(When selecting a DC reactor, refer to *page 62*, and select one suitable for the applicable motor capacity.) When a DC reactor is connected to the FR-A820-03160(55K) or lower, or the FR-A840-01800(55K) or lower, if a jumper is installed across the terminals P1 and P/+, remove the jumper before installing the DC reactor.
- *2 When using separate power supply for the control circuit, remove the jumper between R1/L11 and S1/L21.
- *3 No input voltage is allowed for these terminals. The function of these terminals can be changed with the input terminal assignment (Pr. 178 to Pr. 189). (Refer to *page 40*.)
- *4 Terminal JOG is also used as the pulse train input terminal. Use Pr. 291 to choose JOG or pulse.
- *5 Terminal input specifications can be changed by analog input specification switchover (Pr. 73, Pr. 267). To input a voltage, set the voltage/current input switch OFF. To input a current, set the voltage/current input switch ON. Terminals 10 and 2 are also used as a PTC input terminal. (Pr. 561) (Refer to the FR-A800 Instruction Manual.)
- *6 It is recommended to use 2 W, 1 k Ω when the frequency setting signal is changed frequently.
- *7 If connecting a brake resistor, remove the jumper between PR and PX (FR-A820-00046(0.4K) to 00490(7.5K), FR-A840-00023(0.4K) to 00250(7.5K)).
- *8 Connect a brake resistor across terminals P/+ (P3) and PR. The terminal PR is equipped in FR-A820-00046(0.4K) to 01250(22K), FR-A840-00023(0.4K) to 00620(22K). Install a thermal relay to prevent overheating and damage of discharging resistors. (Refer to the FR-A800 Instruction Manual.)
- *9 Do not connect the DC power supply (under DC feeding mode) to terminal P3.
- *10 The function of these terminals can be changed with the output terminal assignment (Pr. 195, Pr. 196). (Refer to *page 40*.)
- *11 The function of these terminals can be changed with the output terminal assignment (Pr. 190 to Pr. 194). (Refer to *page 40*.)

CAUTION

- To prevent a malfunction due to noise, keep the signal cables more than 10 cm away from the power cables. Also, separate the main circuit cables at the input side from the main circuit cables at the output side.
 - After wiring, wire offcuts must not be left in the inverter.
Wire offcuts can cause an alarm, failure or malfunction. Always keep the inverter clean.
When drilling mounting holes in a control box etc., take care not to allow chips and other foreign matter to enter the inverter.
 - Set the voltage/current input switch in the correct position. An incorrect setting may cause a fault, failure or malfunction.
-



● FM type

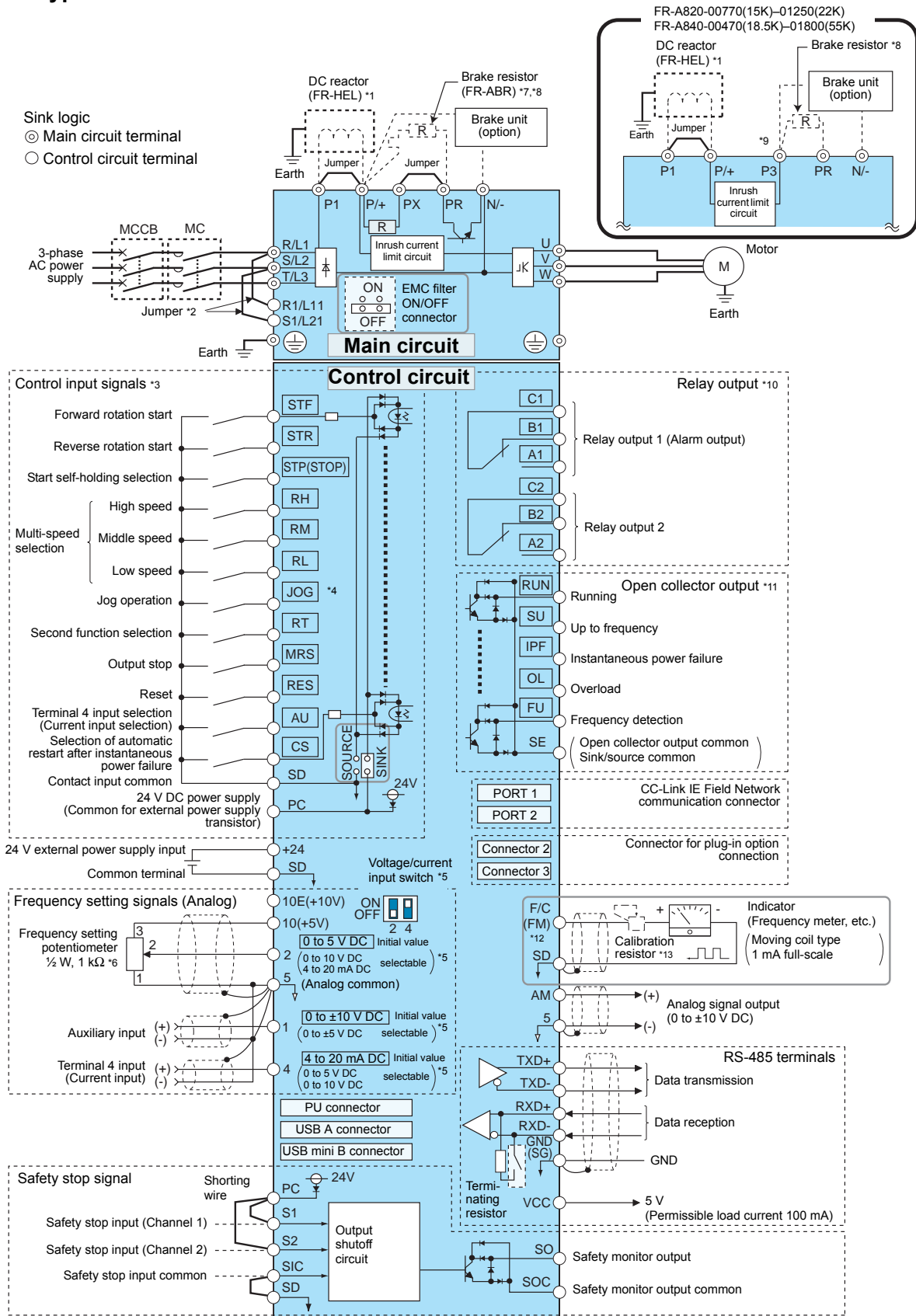

For footnotes *1 to *13 refer to next page.

Note

The model with the symbol GF is not available in Europe. You can get the same functionality of this model by installing the option FR-A8NCE (Art. no. 273102).

- *1 For the FR-A820-03800(75K) or higher, and the FR-A840-02160(75K) or higher, or if using a motor with a capacity of 75 kW or higher, always connect a DC reactor (FR-HEL), which is available as an option.
(When selecting a DC reactor, refer to *page 62*, and select one suitable for the applicable motor capacity.) When a DC reactor is connected to the FR-A820-03160(55K) or lower or the FR-A840-01800(55K) or lower, if a jumper is installed across the terminals P1 and P/+, remove the jumper before installing the DC reactor.
- *2 When using separate power supply for the control circuit, remove the jumper between R1/L11 and S1/L21.
- *3 No input voltage is allowed for these terminals. The function of these terminals can be changed with the input terminal assignment (Pr. 178 to Pr. 189). (Refer to *page 40*.)
- *4 Terminal JOG is also used as the pulse train input terminal. Use Pr. 291 to choose JOG or pulse.
- *5 Terminal input specifications can be changed by analog input specification switchover (Pr. 73, Pr. 267). To input a voltage, set the voltage/current input switch OFF. To input a current, set the voltage/current input switch ON. Terminals 10 and 2 are also used as a PTC input terminal. (Pr. 561) (Refer to the FR-A800 Instruction Manual.)
- *6 It is recommended to use 2 W, 1 k Ω when the frequency setting signal is changed frequently.
- *7 If connecting a brake resistor, remove the jumper between PR and PX (FR-A820-00046(0.4K) to 00490(7.5K), FR-A840-00023(0.4K) to 00250(7.5K)).
- *8 Connect a brake resistor across terminals P/+ (P3) and PR. The terminal PR is equipped in FR-A820-00046(0.4K) to 01250(22K), and FR-A840-00023(0.4K) to 00620(22K). Install a thermal relay to prevent overheating and damage of discharging resistors. (Refer to the FR-A800 Instruction Manual.)
- *9 Do not connect the DC power supply (under DC feeding mode) to terminal P3.
- *10 The function of these terminals can be changed with the output terminal assignment (Pr. 195, Pr. 196). (Refer to *page 40*.)
- *11 The function of these terminals can be changed with the output terminal assignment (Pr. 190 to Pr. 194). (Refer to *page 40*.)
- *12 The terminal F/C(FM) can be used to output pulse trains as open collector output by setting Pr. 291.
- *13 Not required when calibrating the scale with the operation panel.

CAUTION

- To prevent a malfunction due to noise, keep the signal cables more than 10 cm away from the power cables. Also, separate the main circuit cables at the input side from the main circuit cables at the output side.
 - After wiring, wire offcuts must not be left in the inverter.
Wire offcuts can cause an alarm, failure or malfunction. Always keep the inverter clean.
When drilling mounting holes in a control box etc., take care not to allow chips and other foreign matter to enter the inverter.
 - Set the voltage/current input switch in the correct position. An incorrect setting may cause a fault, failure or malfunction.
-



2.1.3 FR-A842(-E)

● CA type

Source logic

- ⊙ Main circuit terminal
- Control circuit terminal

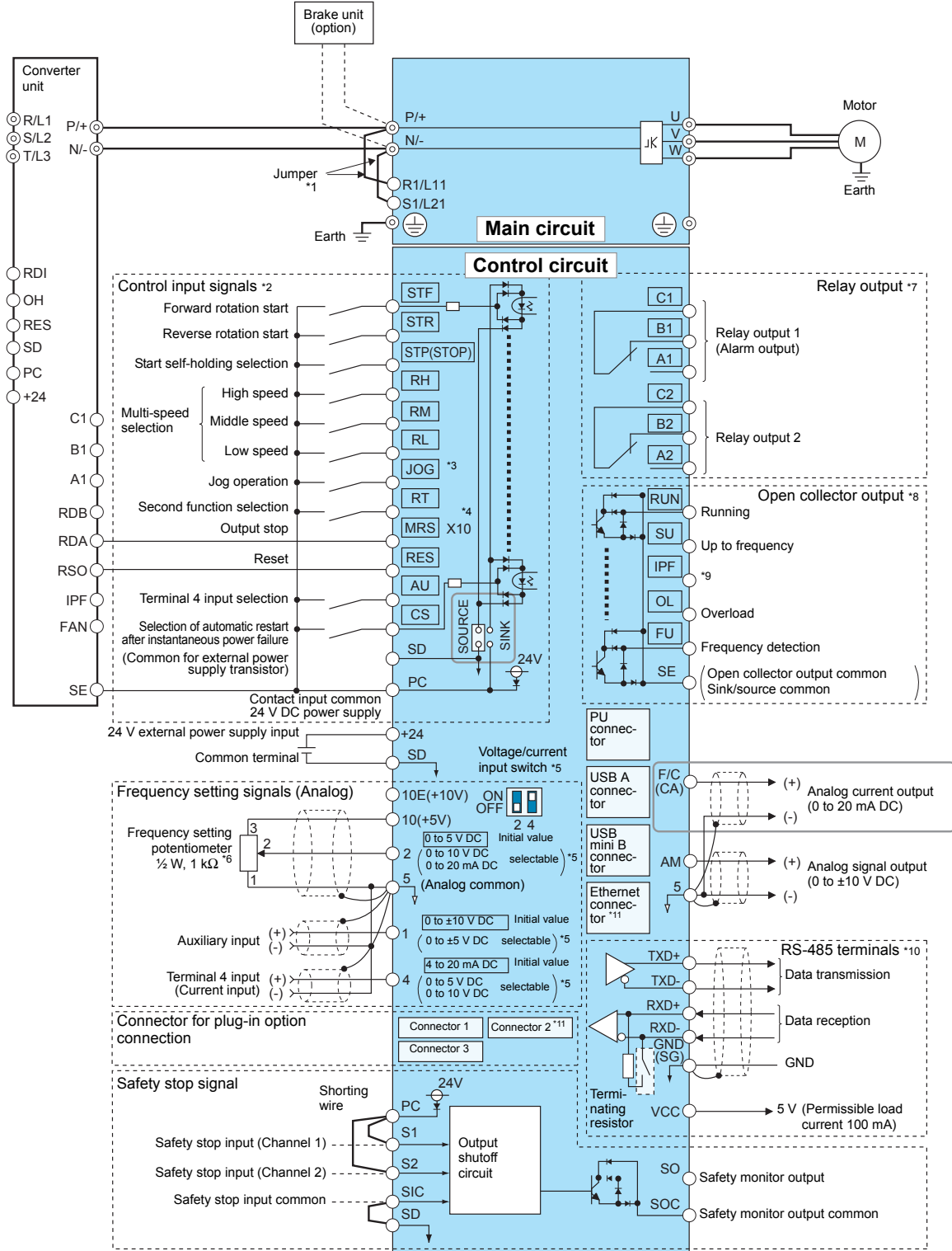

For footnotes *1 to *11 refer to next page.

Note

The FR-A842 models must be operated with a converter unit (FR-CC2), which has to be operated separately. For more details about the installation of the converter unit please refer to the corresponding FR-CC2 Instruction Manual.

- *1 The terminals R1/L11 and S1/L21 are connected to the terminals P/+ and N/- with a jumper respectively. When using separate power supply for the control circuit, remove the jumper between R1/L11 and S1/L21.
- *2 No input voltage is allowed for these terminals. The function of these terminals can be changed with the input terminal assignment (Pr. 178 to Pr. 189). (Refer to *page 40*.)
- *3 Terminal JOG is also used as the pulse train input terminal. Use Pr. 291 to choose JOG or pulse.
- *4 The X10 signal (NC contact input specification) is assigned to the terminal MRS in the initial setting. Set Pr. 599 = "0" to change the input specification of the X10 signal to NO contact.
- *5 Terminal input specifications can be changed by analog input specification switchover (Pr. 73, Pr. 267). To input a voltage (0 to 5 V/0 to 10 V), set the voltage/current input switch OFF. To input a current (4 to 20 mA), set the voltage/current input switch ON. Terminals 10 and 2 are also used as a PTC input terminal. (Pr. 561) (Refer to the FR-A800 Instruction Manual.)
- *6 It is recommended to use 2 W, 1 k Ω when the frequency setting signal is changed frequently.
- *7 The function of these terminals can be changed with the output terminal assignment (Pr. 195, Pr. 196). (Refer to *page 40*.)
- *8 The function of these terminals can be changed with the output terminal assignment (Pr. 190 to Pr. 194). (Refer to *page 40*.)
- *9 No function is assigned in the initial setting. Use Pr. 192 for function assignment.
- *10 Upon delivery the FR-A800-E inverter models are not equipped with the RS-485 terminal block.
- *11 For FR-A800-E: The option connector 2 cannot be used because the Ethernet board is installed in the initial status. The Ethernet board must be removed to install a plug-in option to the option connector 2. (However, Ethernet communication is disabled in that case.)

CAUTION

- To prevent a malfunction due to noise, keep the signal cables more than 10 cm away from the power cables. Also, separate the main circuit cables at the input side from the main circuit cables at the output side.
 - After wiring, wire offcuts must not be left in the inverter.
Wire offcuts can cause an alarm, failure or malfunction. Always keep the inverter clean.
When drilling mounting holes in a control box etc., take care not to allow chips and other foreign matter to enter the inverter.
 - Set the voltage/current input switch in the correct position. An incorrect setting may cause a fault, failure or malfunction.
-



● FM type

- Sink logic
- ⊙ Main circuit terminal
- Control circuit terminal

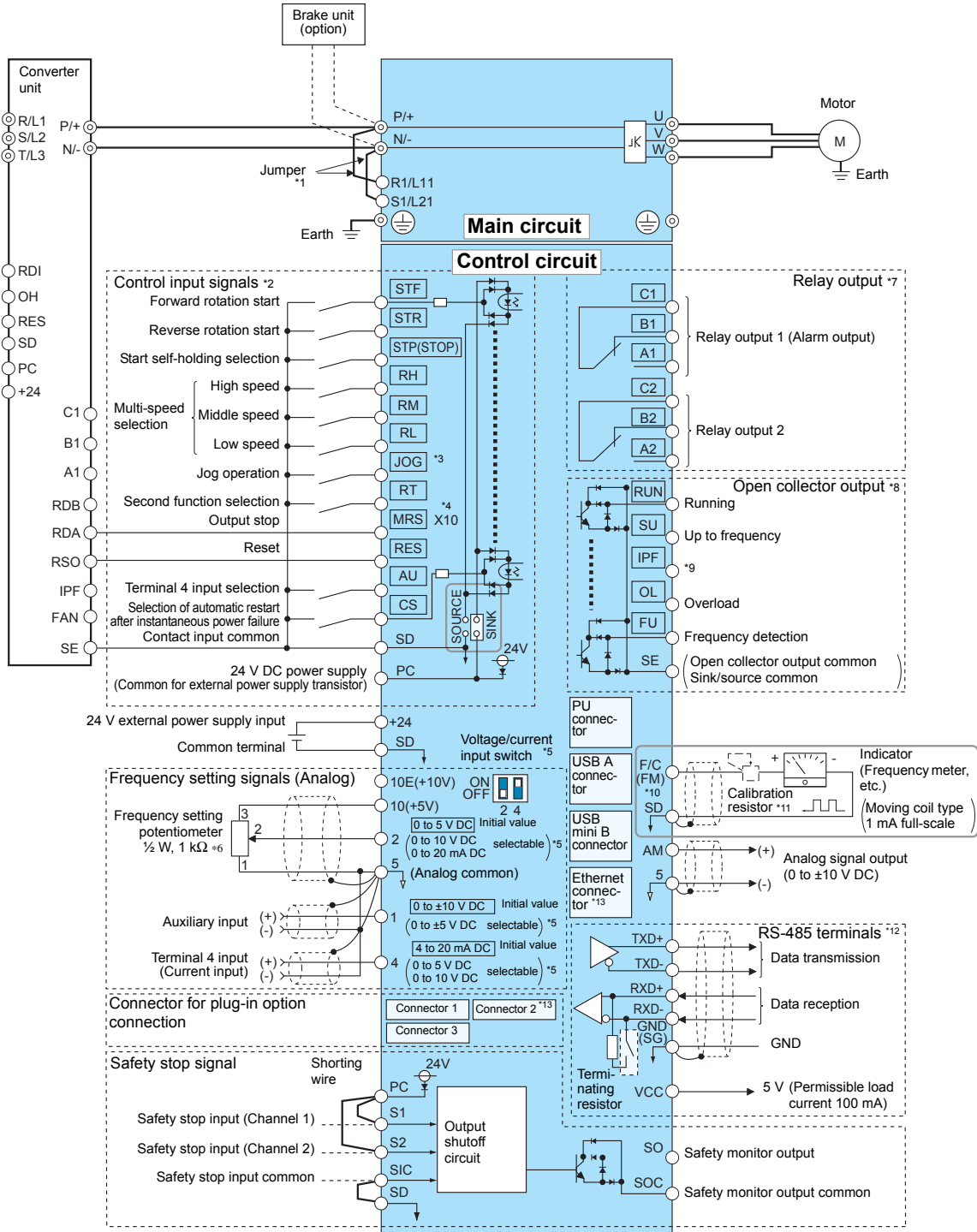

For footnotes *1 to *13 refer to next page.

Note

The FR-A842 models must be operated with a converter unit (FR-CC2), which has to be operated separately. For more details about the installation of the converter unit please refer to the corresponding FR-CC2 Instruction Manual.

- *1 The terminals R1/L11 and S1/L21 are connected to the terminals P/+ and N/- with a jumper respectively. When using separate power supply for the control circuit, remove the jumper between R1/L11 and S1/L21.
- *2 No input voltage is allowed for these terminals. The function of these terminals can be changed with the input terminal assignment (Pr. 178 to Pr. 189). (Refer to *page 40*.)
- *3 Terminal JOG is also used as the pulse train input terminal. Use Pr. 291 to choose JOG or pulse.
- *4 The X10 signal (NC contact input specification) is assigned to the terminal MRS in the initial setting. Set Pr. 599 = "0" to change the input specification of the X10 signal to NO contact.
- *5 Terminal input specifications can be changed by analog input specification switchover (Pr. 73, Pr. 267). To input a voltage (0 to 5 V/0 to 10 V), set the voltage/current input switch OFF. To input a current (4 to 20 mA), set the voltage/current input switch ON. Terminals 10 and 2 are also used as a PTC input terminal. (Pr. 561) (Refer to the FR-A800 Instruction Manual.)
- *6 It is recommended to use 2 W, 1 k Ω when the frequency setting signal is changed frequently.
- *7 The function of these terminals can be changed with the output terminal assignment (Pr. 195, Pr. 196). (Refer to *page 40*.)
- *8 The function of these terminals can be changed with the output terminal assignment (Pr. 190 to Pr. 194). (Refer to *page 40*.)
- *9 No function is assigned in the initial setting. Use Pr.192 for function assignment.
- *10 The terminal F/C (FM) can be used to output pulse trains as open collector output by setting Pr. 291.
- *11 Not required when calibrating the scale with the operation panel.
- *12 Upon delivery the FR-A800-E inverter models are not equipped with the RS-485 terminal block.
- *13 For FR-A800-E: The option connector 2 cannot be used because the Ethernet board is installed in the initial status. The Ethernet board must be removed to install a plug-in option to the option connector 2. (However, Ethernet communication is disabled in that case.)

CAUTION

- To prevent a malfunction due to noise, keep the signal cables more than 10 cm away from the power cables. Also, separate the main circuit cables at the input side from the main circuit cables at the output side.
 - After wiring, wire offcuts must not be left in the inverter.
Wire offcuts can cause an alarm, failure or malfunction. Always keep the inverter clean.
When drilling mounting holes in a control box etc., take care not to allow chips and other foreign matter to enter the inverter.
 - Set the voltage/current input switch in the correct position. An incorrect setting may cause a fault, failure or malfunction.
-



2.1.4 FR-A842-GF

● CA type

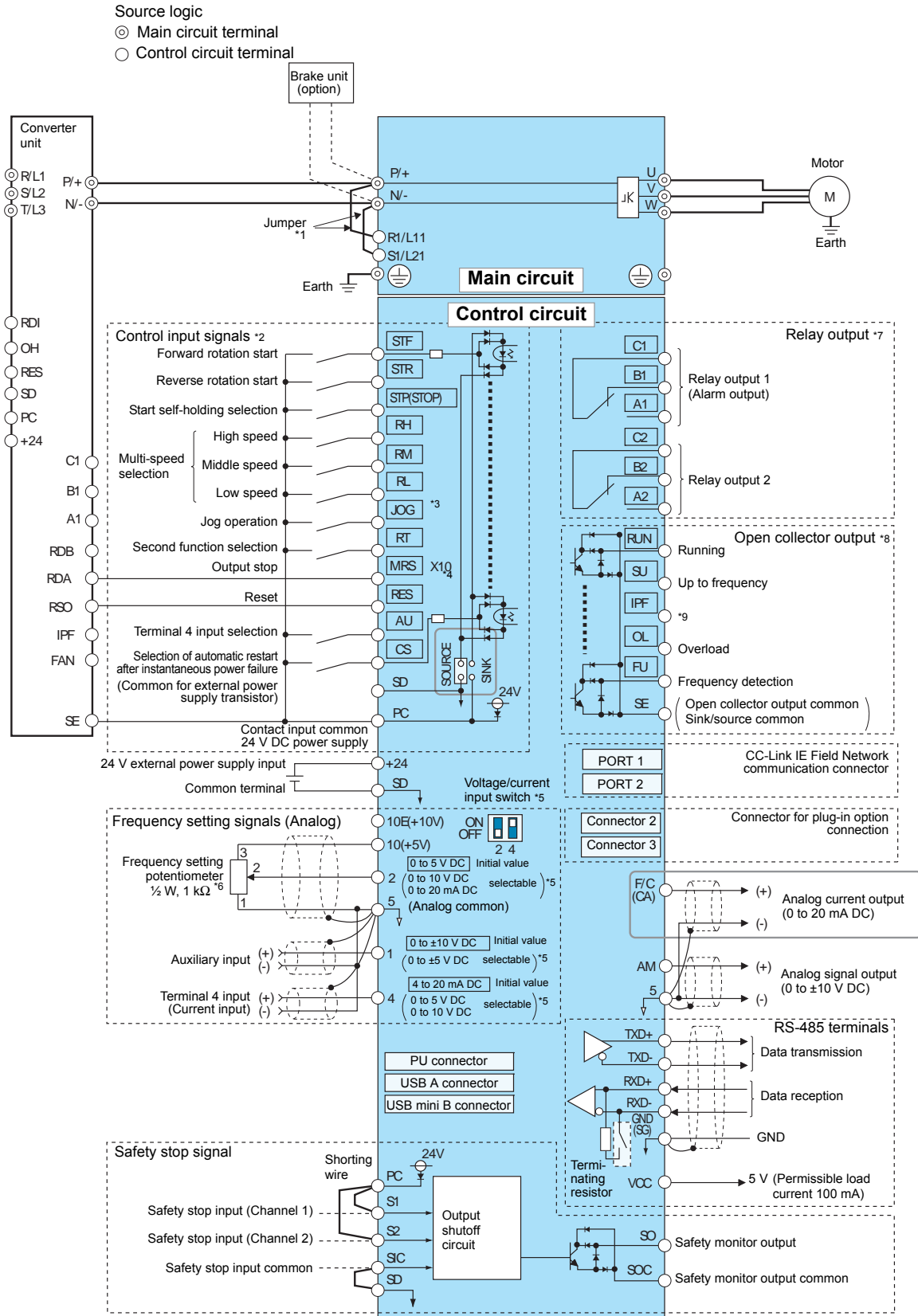

For footnotes *1 to *9 refer to next page.

Notes

- The FR-A842 models must be operated with a converter unit (FR-CC2), which has to be operated separately. For more details about the installation of the converter unit please refer to the corresponding FR-CC2 Instruction Manual.
- The model with the symbol GF is not available in Europe. You can get the same functionality of this model by installing the option FR-A8NCE (Art. no. 273102).

- *1 The terminals R1/L11 and S1/L21 are connected to the terminals P/+ and N/- with a jumper respectively. When using separate power supply for the control circuit, remove the jumper between R1/L11 and S1/L21.
- *2 No input voltage is allowed for these terminals. The function of these terminals can be changed with the input terminal assignment (Pr. 178 to Pr. 189). (Refer to *page 40*.)
- *3 Terminal JOG is also used as the pulse train input terminal. Use Pr. 291 to choose JOG or pulse.
- *4 The X10 signal (NC contact input specification) is assigned to the terminal MRS in the initial setting. Set Pr. 599 = "0" to change the input specification of the X10 signal to NO contact.
- *5 Terminal input specifications can be changed by analog input specification switchover (Pr. 73, Pr. 267). To input a voltage (0 to 5 V/0 to 10 V), set the voltage/current input switch OFF. To input a current (4 to 20 mA), set the voltage/current input switch ON. Terminals 10 and 2 are also used as a PTC input terminal. (Pr. 561) (Refer to the FR-A800 Instruction Manual.)
- *6 It is recommended to use 2 W, 1 k Ω when the frequency setting signal is changed frequently.
- *7 The function of these terminals can be changed with the output terminal assignment (Pr. 195, Pr. 196). (Refer to *page 40*.)
- *8 The function of these terminals can be changed with the output terminal assignment (Pr. 190 to Pr. 194). (Refer to *page 40*.)
- *9 No function is assigned in the initial setting. Use Pr.192 for function assignment.

CAUTION

- To prevent a malfunction due to noise, keep the signal cables more than 10 cm away from the power cables. Also, separate the main circuit cables at the input side from the main circuit cables at the output side.
 - After wiring, wire offcuts must not be left in the inverter.
Wire offcuts can cause an alarm, failure or malfunction. Always keep the inverter clean.
When drilling mounting holes in a control box etc., take care not to allow chips and other foreign matter to enter the inverter.
 - Set the voltage/current input switch in the correct position. An incorrect setting may cause a fault, failure or malfunction.
-



● FM type

Sink logic

- ⊙ Main circuit terminal
- Control circuit terminal

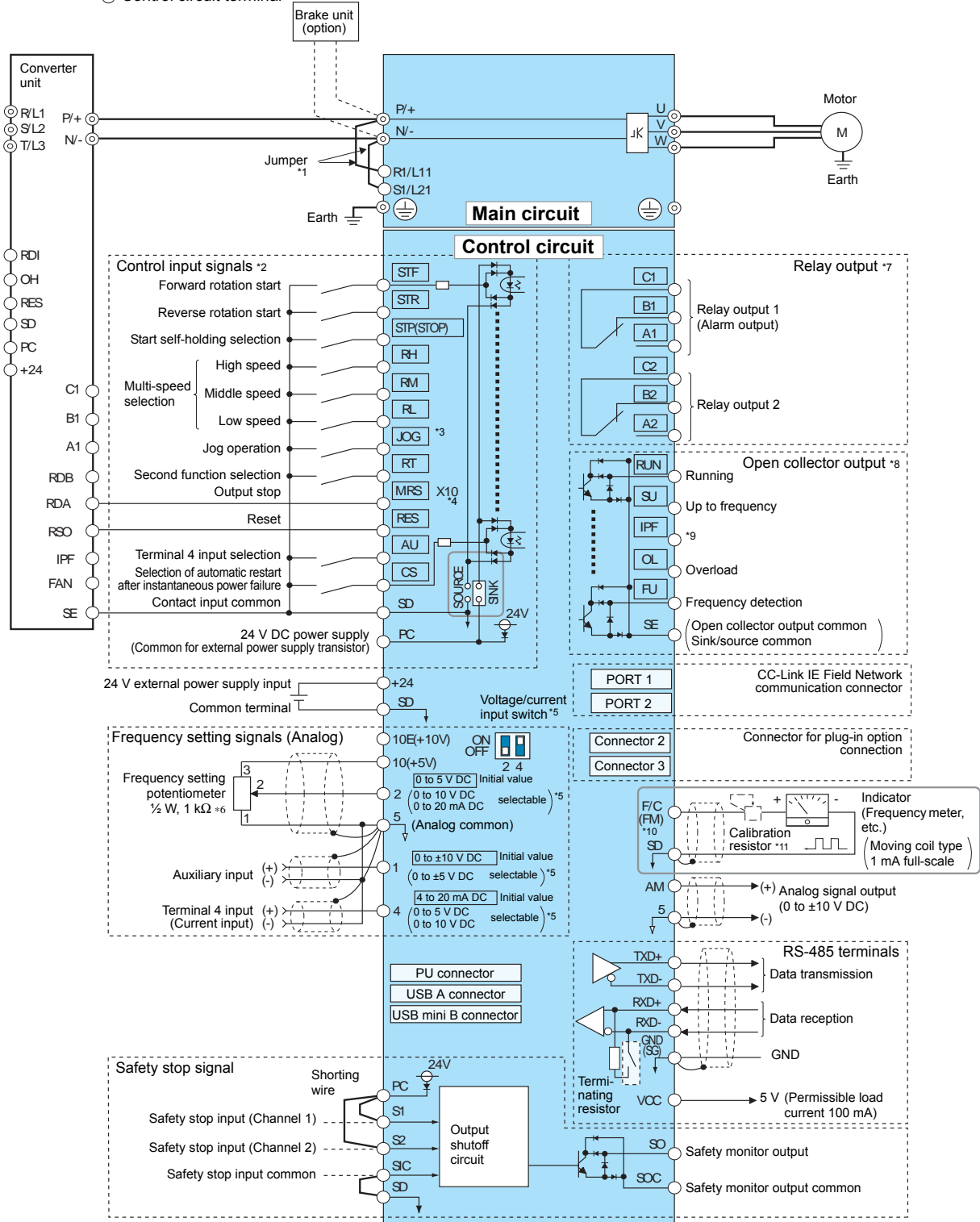

For footnotes *1 to *11 refer to next page.

Notes

- The FR-A842 models must be operated with a converter unit (FR-CC2), which has to be operated separately. For more details about the installation of the converter unit please refer to the corresponding FR-CC2 Instruction Manual.
- The model with the symbol GF is not available in Europe. You can get the same functionality of this model by installing the option FR-A8NCE (Art. no. 273102).

- *1 The terminals R1/L11 and S1/L21 are connected to the terminals P/+ and N/- with a jumper respectively. When using separate power supply for the control circuit, remove the jumper between R1/L11 and S1/L21.
- *2 No input voltage is allowed for these terminals. The function of these terminals can be changed with the input terminal assignment (Pr. 178 to Pr. 189). (Refer to *page 40*.)
- *3 Terminal JOG is also used as the pulse train input terminal. Use Pr. 291 to choose JOG or pulse.
- *4 The X10 signal (NC contact input specification) is assigned to the terminal MRS in the initial setting. Set Pr. 599 = "0" to change the input specification of the X10 signal to NO contact.
- *5 Terminal input specifications can be changed by analog input specification switchover (Pr. 73, Pr. 267). To input a voltage (0 to 5 V/0 to 10 V), set the voltage/current input switch OFF. To input a current (4 to 20 mA), set the voltage/current input switch ON. Terminals 10 and 2 are also used as a PTC input terminal. (Pr. 561) (Refer to the FR-A800 Instruction Manual.)
- *6 It is recommended to use 2 W, 1 k Ω when the frequency setting signal is changed frequently.
- *7 The function of these terminals can be changed with the output terminal assignment (Pr. 195, Pr. 196). (Refer to *page 40*.)
- *8 The function of these terminals can be changed with the output terminal assignment (Pr. 190 to Pr. 194). (Refer to *page 40*.)
- *9 No function is assigned in the initial setting. Use Pr.192 for function assignment.
- *10 The terminal F/C (FM) can be used to output pulse trains as open collector output by setting Pr. 291.
- *11 Not required when calibrating the scale with the operation panel.

CAUTION

- To prevent a malfunction due to noise, keep the signal cables more than 10 cm away from the power cables. Also, separate the main circuit cables at the input side from the main circuit cables at the output side.
 - After wiring, wire offcuts must not be left in the inverter.
Wire offcuts can cause an alarm, failure or malfunction. Always keep the inverter clean.
When drilling mounting holes in a control box etc., take care not to allow chips and other foreign matter to enter the inverter.
 - Set the voltage/current input switch in the correct position. An incorrect setting may cause a fault, failure or malfunction.
-



2.1.5 FR-A846(-E)

● CA type

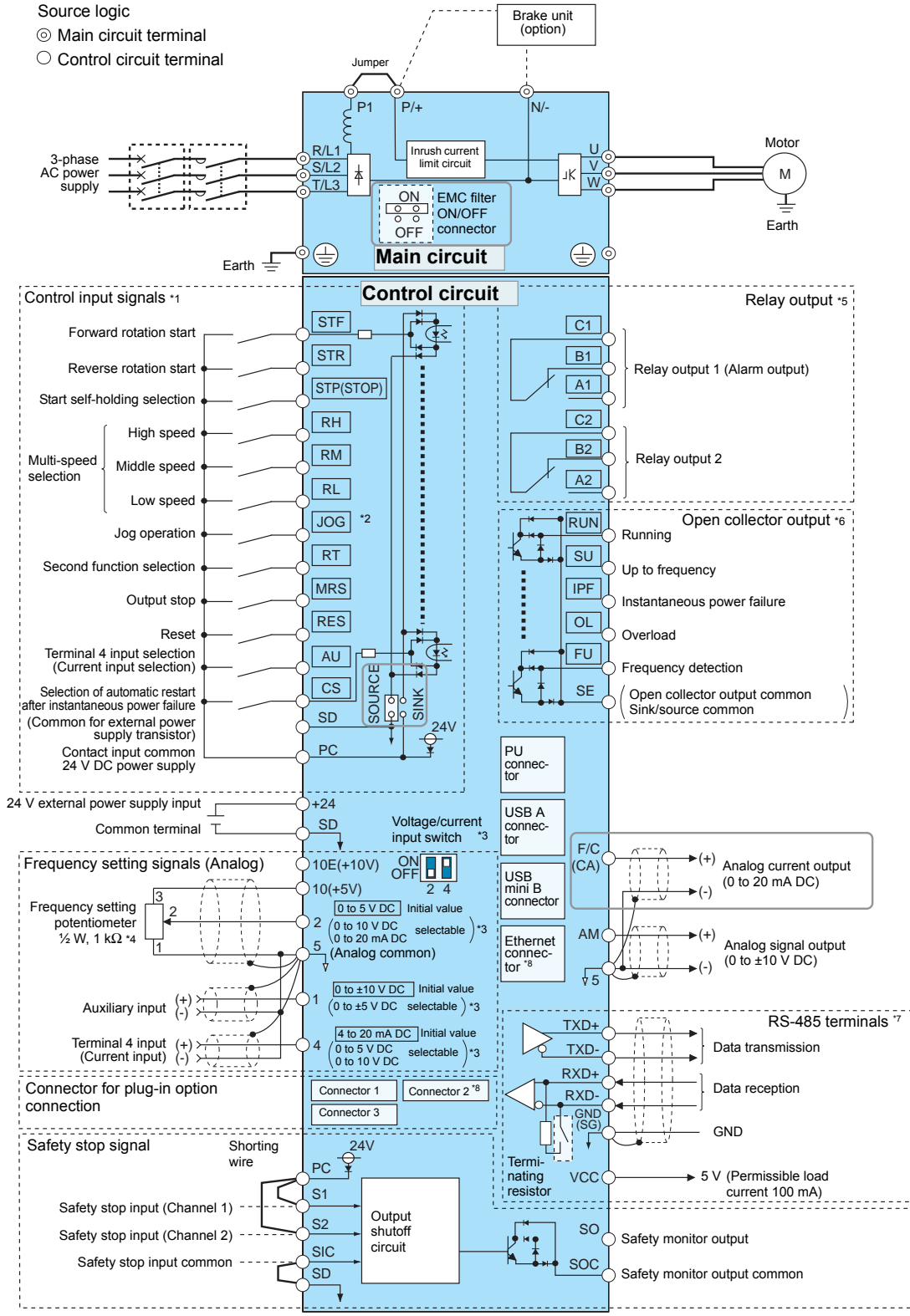

For footnotes *1 to *8 refer to next page.

- *1 No input voltage is allowed for these terminals. The function of these terminals can be changed with the input terminal assignment (Pr. 178 to Pr. 189). (Refer to *page 40*.)
- *2 Terminal JOG is also used as the pulse train input terminal. Use Pr. 291 to choose JOG or pulse.
- *3 Terminal input specifications can be changed by analog input specification switchover (Pr. 73, Pr. 267). To input a voltage (0 to 5 V/0 to 10 V), set the voltage/current input switch OFF. To input a current (4 to 20 mA), set the voltage/current input switch ON. Terminals 10 and 2 are also used as a PTC input terminal. (Pr. 561) (Refer to the FR-A800 Instruction Manual.)
- *4 It is recommended to use 2 W, 1 k Ω when the frequency setting signal is changed frequently.
- *5 The function of these terminals can be changed with the output terminal assignment (Pr. 195, Pr. 196). (Refer to *page 40*.)
- *6 The function of these terminals can be changed with the output terminal assignment (Pr. 190 to Pr. 194). (Refer to *page 40*.)
- *7 Upon delivery the FR-A800-E inverter models are not equipped with the RS-485 terminal block.
- *8 For FR-A800-E: The option connector 2 cannot be used because the Ethernet board is installed in the initial status. The Ethernet board must be removed to install a plug-in option to the option connector 2. (However, Ethernet communication is disabled in that case.)

CAUTION

- To prevent a malfunction due to noise, keep the signal cables more than 10 cm away from the power cables. Also, separate the main circuit cables at the input side from the main circuit cables at the output side.
 - After wiring, wire offcuts must not be left in the inverter.
Wire offcuts can cause an alarm, failure or malfunction. Always keep the inverter clean.
When drilling mounting holes in a control box etc., take care not to allow chips and other foreign matter to enter the inverter.
 - Set the voltage/current input switch in the correct position. An incorrect setting may cause a fault, failure or malfunction.
-



● FM type

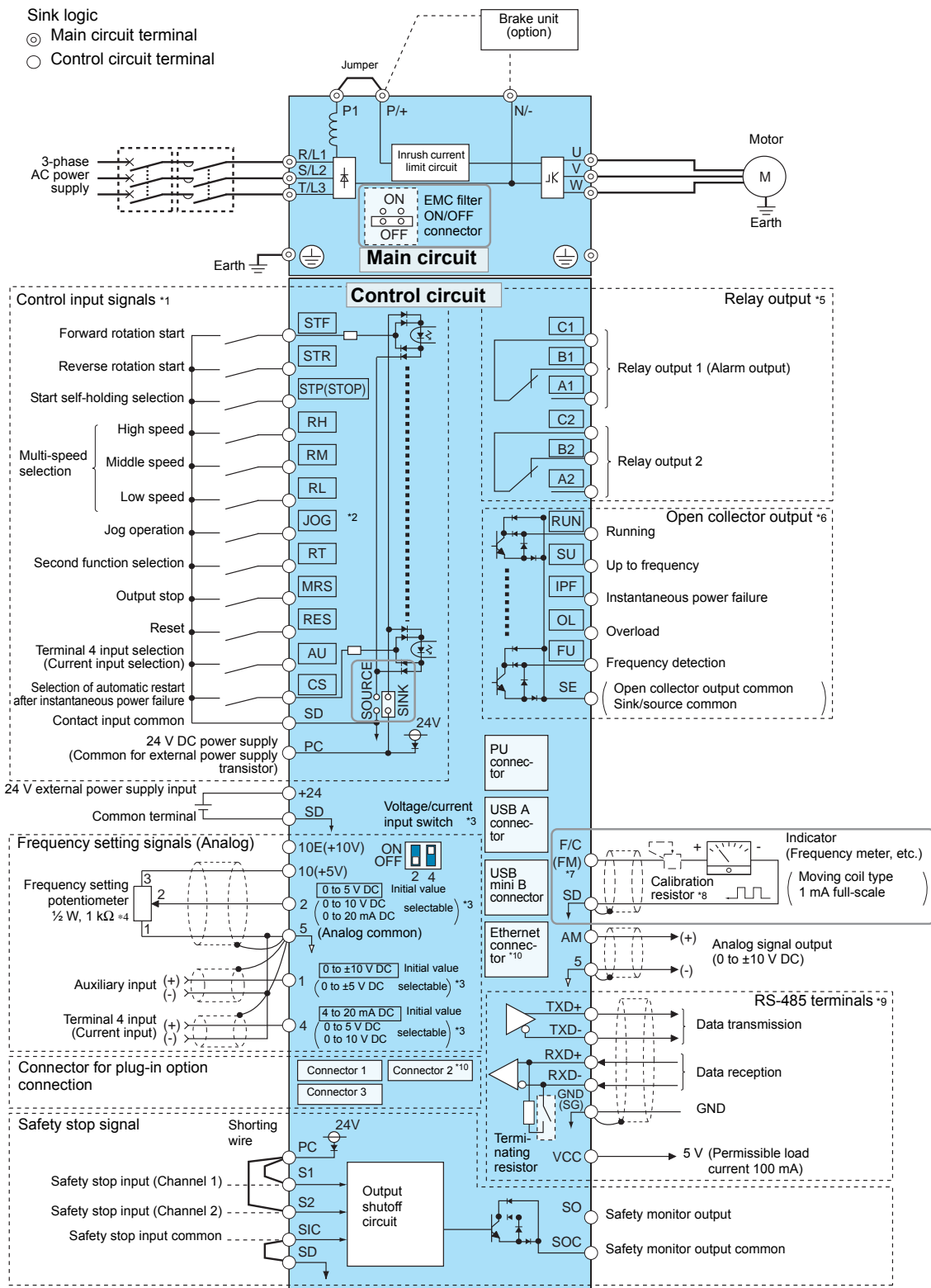

For footnotes *1 to *10 refer to next page.

- *1 No input voltage is allowed for these terminals. The function of these terminals can be changed with the input terminal assignment (Pr. 178 to Pr. 189). (Refer to *page 40*.)
- *2 Terminal JOG is also used as the pulse train input terminal. Use Pr. 291 to choose JOG or pulse.
- *3 Terminal input specifications can be changed by analog input specification switchover (Pr. 73, Pr. 267). To input a voltage (0 to 5 V/0 to 10 V), set the voltage/current input switch OFF. To input a current (4 to 20 mA), set the voltage/current input switch ON. Terminals 10 and 2 are also used as a PTC input terminal. (Pr. 561) (Refer to the FR-A800 Instruction Manual.)
- *4 It is recommended to use 2 W, 1 k Ω when the frequency setting signal is changed frequently.
- *5 The function of these terminals can be changed with the output terminal assignment (Pr. 195, Pr. 196). (Refer to *page 40*.)
- *6 The function of these terminals can be changed with the output terminal assignment (Pr. 190 to Pr. 194). (Refer to *page 40*.)
- *7 The terminal F/C (FM) can be used to output pulse trains as open collector output by setting Pr. 291.
- *8 Not required when calibrating the scale with the operation panel.
- *9 Upon delivery the FR-A800-E inverter models are not equipped with the RS-485 terminal block.
- *10 For FR-A800-E: The option connector 2 cannot be used because the Ethernet board is installed in the initial status. The Ethernet board must be removed to install a plug-in option to the option connector 2. (However, Ethernet communication is disabled in that case.)

CAUTION

- To prevent a malfunction due to noise, keep the signal cables more than 10 cm away from the power cables. Also, separate the main circuit cables at the input side from the main circuit cables at the output side.
 - After wiring, wire offcuts must not be left in the inverter.
Wire offcuts can cause an alarm, failure or malfunction. Always keep the inverter clean.
When drilling mounting holes in a control box etc., take care not to allow chips and other foreign matter to enter the inverter.
 - Set the voltage/current input switch in the correct position. An incorrect setting may cause a fault, failure or malfunction.
-



2.2 Main circuit terminal

2.2.1 Terminal layout and wiring

<p>FR-A820-00046(0.4K), 00077(0.75K)</p> <p>Power supply Motor Charge lamp</p>	<p>FR-A820-00105(1.5K) to 00250(3.7K) FR-A840-00023(0.4K) to 00126(3.7K)</p> <p>Power supply Motor Charge lamp</p>	<p>FR-A820-00340(5.5K), 00490(7.5K) FR-A840-00170(5.5K), 00250(7.5K)</p> <p>Charge lamp Power supply Motor</p>
<p>FR-A820-00630(11K) FR-A840-00310(11K), 00380(15K)</p> <p>Charge lamp Power supply Motor</p>	<p>FR-A820-00770(15K) to 01250(22K) FR-A840-00470(18.5K), 00620(22K)</p> <p>Power supply Motor Charge lamp Jumper</p>	<p>FR-A820-01540(30K) *2 FR-A840-00770(30K)</p> <p>Power supply Motor Charge lamp Jumper</p>
<p>FR-A820-01870(37K), 02330(45K) *1</p> <p>Power supply Motor Jumper</p>	<p>FR-A820-03160(55K) *1</p> <p>Power supply Motor Jumper</p>	<p>FR-A840-00930(37K) to 01800(55K) *1</p> <p>Power supply Motor Jumper</p>
<p>FR-A840-02160(75K), 02600(90K) *1</p> <p>Power supply DC reactor Motor</p>	<p>FR-A820-03800(75K), 04750(90K) *1 FR-A840-03250(110K) to 04810(185K) *1</p> <p>Power supply For option DC reactor Motor</p>	<p>FR-A840-05470(220K) to 06830(280K) *1</p> <p>Power supply DC reactor Motor</p>
<p>FR-A842-07700(315K) to 12120(500K) *3</p> <p>To converter unit Motor</p>	<p>FR-A846-00023(0.4K) to 00170(5.5K)</p> <p>Power supply Motor Charge lamp Jumper</p>	<p>FR-A846-00250(7.5K) to 00470(18.5K)</p> <p>Power supply Motor Charge lamp Jumper</p>

For footnotes *1 to *3 refer to next page.

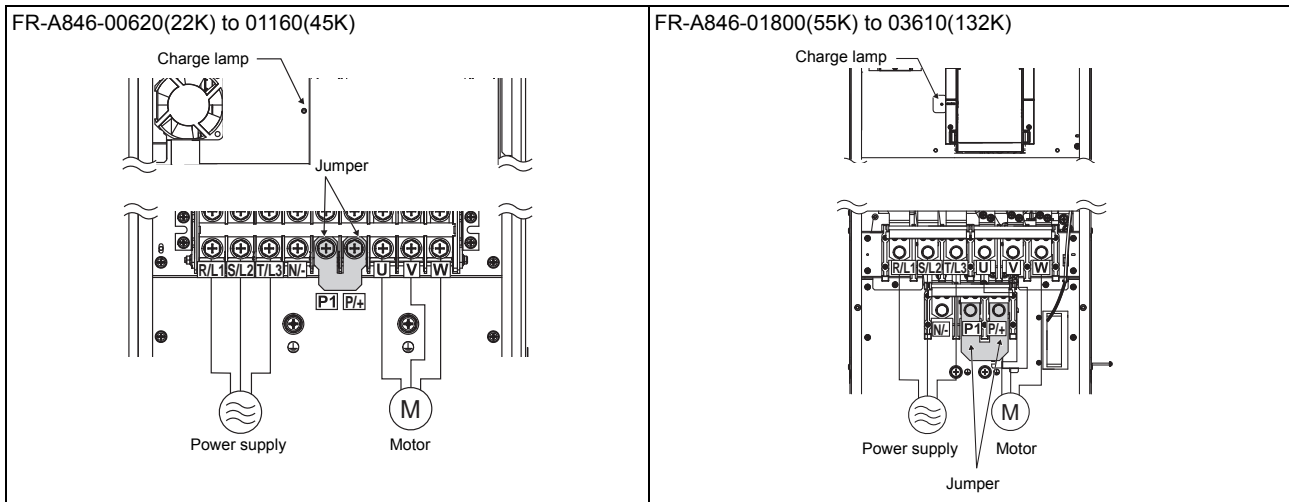

*1 The following diagram shows the positions of R1/L11, S1/L21, and the charge lamp.

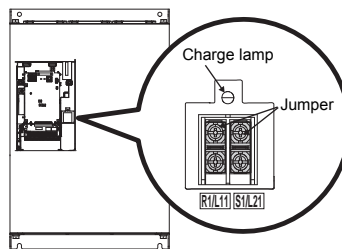

*2 The terminals P3 and PR of the FR-A820-01540(30K) are not equipped with screws. Do not connect anything to these.

*3 For terminal layout and wiring of the converter unit (FR-CC2) refer to the FR-CC2 Instruction Manual.

CAUTION

- The power supply cables must be connected to R/L1, S/L2, T/L3. Never connect the power cable to the U, V, W, of the inverter. Doing so will damage the inverter. (Phase sequence needs not to be matched.)
- Connect the motor to U, V, W. At this time turning on the forward rotation switch (signal) rotates the motor in the clockwise direction when viewed from the motor shaft. (The phase sequence must be matched.)
- The charge lamp will turn ON when the power is supplied to the main circuit.
- When wiring the inverter main circuit conductor of the FR-A840-05470(220K) or higher, tighten a nut from the right side of the conductor. When wiring two wires, place wires on both sides of the conductor (refer to the drawing). For wiring, use bolts (nuts) provided with the inverter.

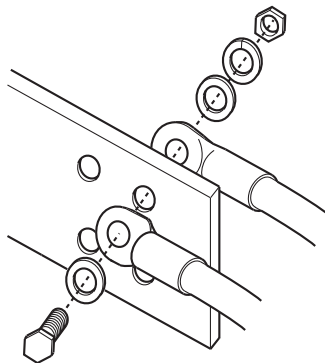

- For wiring the main circuit conductor of the converter unit (FR-CC2) refer to the FR-CC2 Instruction Manual.



2.3 Wiring fundamentals

2.3.1 Cable size

Select the recommended cable size to ensure that a voltage drop will be 2% max.

If the wiring distance is long between the inverter and motor, a main circuit cable voltage drop will cause the motor torque to decrease especially at the output of a low frequency.

The following tables indicate a selection example for the wiring length of 20m.

200 V class, FR-A820 (when input power supply is 220 V based on the rated current for 150% overload for 1 minute)

Applicable inverter type FR-A820-□	Terminal screw size *4	Tightening torque [Nm]	Crimping terminal		Cable sizes								
					HIV, etc. [mm ²] *1				AWG/MCM *2		PVC, etc. [mm ²] *3		
			R/L1, S/L2, T/L3	U, V, W	R/L1, S/L2, T/L3	U, V, W	P/+, P1	Earth cable gauge	R/L1, S/L2, T/L3	U, V, W	R/L1, S/L2, T/L3	U, V, W	Earth cable gauge
00046(0.4K) to 00167(2.2K)	M4	1.5	2-4	2-4	2	2	2	2	14	14	2.5	2.5	2.5
00250(3.7K)	M4	1.5	5.5-4	5.5-4	3.5	3.5	3.5	3.5	12	12	4	4	4
00340(5.5K)	M5 (M4)	2.5	5.5-5	5.5-5	5.5	5.5	5.5	5.5	10	10	6	6	6
00490(7.5K)	M5 (M4)	2.5	14-5	8-5	14	8	14	5.5	6	8	16	10	16
00630(11K)	M5	2.5	14-5	14-5	14	14	14	8	6	6	16	16	16
00770(15K)	M6	4.4	22-6	22-6	22	22	22	14	4	4	25	25	16
00930(18.5K)	M8 (M6)	7.8	38-8	22-8	38	22	38	14	2	4	35	25	25
01250(22K)	M8 (M6)	7.8	38-8	38-8	38	38	38	22	2	2	35	35	25
01540(30K)	M8 (M6)	7.8	60-8	60-8	60	60	60	22	1/0	1/0	50	50	25
01870(37K)	M10 (M8)	14.7	80-10	60-10	80	60	80	22	3/0	1/0	70	70	35
02330(45K)	M10 (M8)	14.7	100-10	100-10	100	100	100	38	4/0	4/0	95	95	50
03160(55K)	M12 (M8)	24.5	100-12	100-12	100	100	100	38	4/0	4/0	95	95	50
03800(75K)	M12 (M8)	24.5	150-12	150-12	125	125	150	38	250	250	—	—	—
04750(90K)	M12 (M8)	24.5	150-12	150-12	150	150	2x100	60	300	300	—	—	—

*1 For the FR-A820-03160(55K) or lower the recommended cable size is that of the HIV cable (600 V class 2 vinyl-insulated cable) with continuous maximum permissible temperature of 75°C. Assumes that the surrounding air temperature is 50°C or less and the wiring distance is 20 m or less.

For the FR-A820-03800(75K) or higher the recommended cable size is that of the LMFC cable (heat resistant flexible cross-linked polyethylene insulated cable) with continuous maximum permissible temperature of 90°C. Assumes that the surrounding air temperature is 50°C or less and wiring is performed in an enclosure.

*2 The recommended cable size is that of the THHW cable with continuous maximum permissible temperature of 75°C. Assumes that the surrounding air temperature is 40°C or less and the wiring distance is 20 m or less. (Selection example for use mainly in the United States.)

*3 For the FR-A820-00770(15K) or lower the recommended cable size is that of the PVC cable with continuous maximum permissible temperature of 70°C. Assumes that the surrounding air temperature is 40°C or less and the wiring distance is 20 m or less. For the FR-A820-00930(18.5K) or higher the recommended cable size is that of XLPE cable with continuous maximum permissible temperature of 90°C. Assumes that the surrounding air temperature is 40°C or less and wiring is performed in an enclosure. (Selection example for use mainly in Europe.)

*4 The terminal screw size indicates the terminal size for R/L1, S/L2, T/L3, U, V, W, PR, PX, P/+, N/–, P1, P3, and a screw for earthing. The screw size for PR and PX terminals of FR-A820-00340(5.5K) and FR-A820-00490(7.5K) is indicated in brackets. The screw size for earthing of FR-A820-00930(18.5K) or higher is indicated in brackets.

400 V class, FR-A840/A846

(when input power supply is 440 V based on the rated current for 150% overload for 1 minute)

Applicable inverter type FR-A840-□	Terminal screw size *4	Tightening Torque [Nm]	Crimping terminal		Cable sizes								
					HIV, etc. [mm ²] *1				AWG/MCM *2		PVC, etc. [mm ²] *3		
			R/L1, S/L2, T/L3	U, V, W	R/L1, S/L2, T/L3	U, V, W	P/+, P1	Earth cable gauge	R/L1, S/L2, T/L3	U, V, W	R/L1, S/L2, T/L3	U, V, W	Earth cable gauge
00023(0.4K) to 00126(3.7K)	M4	1.5	2-4	2-4	2	2	2	2	14	14	2.5	2.5	2.5
00170(5.5K)	M4	1.5	2-4	2-4	2	2	3.5	3.5	12	14	2.5	2.5	4
00250(7.5K)	M4	1.5	5.5-4	5.5-4	3.5	3.5	3.5	3.5	12	12	4	4	4
00310(11K)	M5	2.5	5.5-5	5.5-5	5.5	5.5	5.5	5.5	10	10	6	6	10
00380(15K)	M5	2.5	8-5	5.5-5	8	5.5	8	5.5	8	10	10	6	10
00470(18.5K)	M6	4.4	14-6	8-6	14	8	14	8	6	8	16	10	16
00620(22K)	M6	4.4	14-6	14-6	14	14	22	14	6	6	16	16	16
00770(30K)	M6	4.4	22-6	22-6	22	22	22	14	4	4	25	25	16
00930(37K)	M8	7.8	22-8	22-8	22	22	22	14	4	4	25	25	16
01160(45K)	M8	7.8	38-8	38-8	38	38	38	22	1	2	50	50	25
01800(55K)	M8	7.8	60-8	60-8	60	60	60	22	1/0	1/0	50	50	25
02160(75K)	M10	14.7	60-10	60-10	60	60	60	22	1/0	1/0	50	50	25
02600(90K)	M10	14.7	60-10	60-10	60	60	80	22	3/0	3/0	50	50	25
03250(110K)	M10 (M12)	14.7	80-10	80-10	80	80	80	38	3/0	3/0	70	70	35
03610(132K)	M10 (M12)	14.7	100-10	100-10	100	100	100	38	4/0	4/0	95	95	50
04320(160K)	M12 (M10)	24.5	150-12	150-12	125	125	150	38	250	250	120	120	70
04810(185K)	M12 (M10)	24.5	150-12	150-12	150	150	150	38	300	300	150	150	95
05470(220K)	M12 (M10)	46	100-12	100-12	2×100	2×100	2×100	60	2×4/0	2×4/0	2×95	2×95	95
06100(250K)	M12 (M10)	46	100-12	100-12	2×100	2×100	2×125	60	2×4/0	2×4/0	2×95	2×95	95
06830(280K)	M12 (M10)	46	150-12	150-12	2×125	2×125	2×125	60	2×250	2×250	2×120	2×120	120

Applicable inverter type FR-A846-□	Terminal screw size *4	Tightening torque [Nm]	Crimping terminal		Cable sizes								
					HIV, etc. [mm ²] *1				AWG/MCM *2		PVC, etc. [mm ²] *3		
			R/L1, S/L2, T/L3	U, V, W	R/L1, S/L2, T/L3	U, V, W	P/+, P1	Earth cable gauge	R/L1, S/L2, T/L3	U, V, W	R/L1, S/L2, T/L3	U, V, W	Earth cable gauge
00023(0.4K) to 00126(5.5K)	M4	1.5	2-4	2-4	2	2	2	2	14	14	2.5	2.5	2.5
00170(5.5K)	M4	1.5	2-4	2-4	2	2	3.5	3.5	12	14	2.5	2.5	4
00250(7.5K)	M6	4.4	5.5-6	5.5-6	3.5	3.5	3.5	3.5	12	12	4	4	4
00310(11K)	M6	4.4	5.5-6	5.5-6	5.5	5.5	5.5	5.5	10	10	6	6	10
00380(15K)	M6	4.4	5.5-6	5.5-6	5.5	5.5	8	5.5	10	10	6	6	10
00470(18.5K)	M6	4.4	8-6	8-6	8	8	14	8	8	8	10	10	16
00620(22K)	M6	4.4	14-6	14-6	14	14	22	14	6	6	16	16	16
00770(30K)	M6	4.4	22-6	22-6	22	22	22	14	4	4	25	25	16
00930(37K)	M8	7.8	22-8	22-8	22	22	22	14	4	4	25	25	16
01160(45K)	M8	7.8	38-8	38-8	38	38	38	22	2	2	50	50	25
01800(55K)	M10	14.7	60-10	60-10	60	60	60	22	1/0	1/0	50	50	25
02160(75K)	M10	14.7	60-10	60-10	60	60	60	22	1/0	1/0	50	50	25
02600(90K)	M10	14.7	60-10	60-10	60	60	80	22	3/0	3/0	50	50	25
03250(110K)	M10	14.7	80-10	80-10	80	80	80	38	3/0	3/0	70	70	35
03610(132K)	M10	14.7	100-10	100-10	100	100	100	38	4/0	4/0	95	95	50

For footnotes *1 to *4 refer to next page.



- ^{*1} For the FR-A840-01800(55K) or lower, and the FR-A846-01800(55K) or lower, the recommended cable size is that of the HIV cable (600 V class 2 vinyl-insulated cable) with continuous maximum permissible temperature of 75°C. Assumes that the surrounding air temperature is 50°C or less and the wiring distance is 20 m or less.
For the FR-A840-02160(75K) or higher, and the FR-A846-02160(75K) or higher, the recommended cable size is that of the LMFC cable (heat resistant flexible cross-linked polyethylene insulated cable) with continuous maximum permissible temperature of 90°C. Assumes that the surrounding air temperature is 50°C or less and wiring is performed in an enclosure.
- ^{*2} For the FR-A840-01160(45K) or lower, and the FR-A846-01160(45K) or lower, the recommended cable size is that of the THHW cable with continuous maximum permissible temperature of 75°C. Assumes that the surrounding air temperature is 40°C or less and the wiring distance is 20m or less.
For the FR-A840-01800(55K) or higher, and the FR-A846-01800(55K) or higher, the recommended cable size is that of THHN cable with continuous maximum permissible temperature of 90°C. Assumes that the surrounding air temperature is 40°C or less and wiring is performed in an enclosure.
(Selection example for use mainly in the United States.)
- ^{*3} For the FR-A840-01160(45K) or lower, and the FR-A846-01160(45K) or lower, the recommended cable size is that of the PVC cable with continuous maximum permissible temperature of 70°C. Assumes that the surrounding air temperature is 40°C or less and the wiring distance is 20m or less.
For the FR-A840-01800(55K) or higher, and the FR-A846-01800(55K) or higher, the recommended cable size is that of XLPE cable with continuous maximum permissible temperature of 90°C. Assumes that the surrounding air temperature is 40°C or less and wiring is performed in an enclosure. (Selection example for use mainly in Europe.)
- ^{*4} The terminal screw size for the FR-A840 models indicates the terminal size for R/L1, S/L2, T/L3, U, V, W, PR, PX, P/+, N/–, P1, P3, and a screw for earthing.
The terminal screw size for the FR-A846 (IP55 compatible) models indicates the terminal size for R/L1, S/L2, T/L3, U, V, W, P/+, N/–, P1 and a screw for earthing.
The screw size for P/+ terminal for connecting an option to FR-A840-03250(110K) or FR-A840-03610(132K) is indicated in brackets.
The screw size for earthing (grounding) of FR-A840-04320(160K) or higher is indicated in brackets.

400 V class, FR-A842 (when input power supply is 440 V based on the rated current for 150% overload for 1 minute)

(For the applicable cables of the converter unit (FR-CC2) refer to the FR-CC2 Instruction Manual.)

Applicable inverter type FR-A842-□	Terminal screw size ^{*4}	Tightening torque [Nm]	Crimping terminal	Cable sizes					
				HIV, etc. [mm ²] ^{*1}			AWG/ MCM ^{*2}	PVC, etc. [mm ²] ^{*3}	
				U, V, W	U, V, W	P/+, N/–	Earth cable gauge	U, V, W	U, V, W
07700(315K)	M12 (M10)	46	150-12	2×150	2×150	100	2×300	2×150	150
08660(355K)	M12 (M10)	46	C2-200	2×200	2×200	100	2×350	2×185	2×95
09620(400K)	M12 (M10)	46	C2-200	2×200	2×200	100	2×400	2×185	2×95
10940(450K)	M12 (M10)	46	C2-250	2×250	2×250	100	2×500	2×240	2×120
12120(500K)	M12 (M10)	46	C2-250	2×250	3×200	2×100	2×500	2×240	2×120

- ^{*1} The recommended cable size is that of the LMFC cable (heat resistant flexible cross-linked polyethylene insulated cable) with continuous maximum permissible temperature of 90°C. Assumes that the surrounding air temperature is 40°C or less and wiring is performed in an enclosure.
- ^{*2} The recommended cable size is that of THHN cable with continuous maximum permissible temperature of 90°C. Assumes that the surrounding air temperature is 40°C or less and wiring is performed in an enclosure.
(Selection example for use mainly in the United States.)
- ^{*3} The recommended cable size is that of XLPE cable with continuous maximum permissible temperature of 90°C. Assumes that the surrounding air temperature is 40°C or less and wiring is performed in an enclosure. (Selection example for use mainly in Europe.)
- ^{*4} The terminal screw size indicates the terminal size for R/L1, S/L2, T/L3, U, V, W, P/+, N/– and a screw for earthing.
The screw size for earthing (grounding) is indicated in brackets.

The line voltage drop can be calculated by the following expression:

$$\text{Line voltage drop [V]} = \frac{\sqrt{3} \times \text{wire resistance [m}\Omega\text{/m]} \times \text{wiring distance [m]} \times \text{current [A]}}{1000}$$

Use a larger diameter cable when the wiring distance is long or when it is desired to decrease the voltage drop (torque reduction) in the low speed range.

CAUTION

- The above shows a selection example for the ND rating. For selecting the SLD rating, LD rating, or HD rating, refer to the Technical News (MF-X-121) contained in the enclosed CD-ROM. For selecting the ratings of FR-A842 refer to the FR-A802 Instruction Manual.
- Tighten the terminal screw to the specified torque.
A screw that has been tightened too loosely can cause a short circuit or malfunction.
A screw that has been tightened too tightly can cause a short circuit or malfunction due to the unit breakage.
- Use crimping terminals with insulation sleeve to wire the power supply and motor.

2.3.2 Total wiring length

◆ With general-purpose motor

Connect one or more general-purpose motors within the total wiring length shown in the following table.
(The wiring length should be 100 m or less under vector control.)

Pr. 72 setting (carrier frequency)	FR-A820-00046(0.4K), FR-A840-00023(0.4K), FR-A846-00023(0.4K)	FR-A820-00077(0.75K), FR-A840-00038(0.75K), FR-A846-00038(0.75K)	FR-A820-00105(1.5K) or higher, FR-A840-00052(1.5K) or higher, FR-A842-07700(315K) to 12120(500K), FR-A846-00052(1.5K) or higher
2 (2 kHz) or lower	300 m	500 m	500 m
3 (3 kHz) or higher	200 m	300 m	500 m

When driving a 400 V class motor by the inverter, surge voltages attributable to the wiring constants may occur at the motor terminals, deteriorating the insulation of the motor. In this case, take one of the following measure.

- Use a "400 V class inverter-driven insulation-enhanced motor" and set frequency in Pr. 72 "PWM frequency selection" according to wiring length.

	Wiring length		
	≤ 50 m	50 m–100 m	≥ 100 m
Pr. 72 setting	≤ 15 (14.5 kHz)	≤ 9 (9 kHz)	≤ 4 (4 kHz)
	IP55 compatible models: ≤ 6 (6 kHz)		

- Connect the surge voltage suppression filter (FR-ASF-H, FR-BMF-H) to the output side of the FR-A840-01800(55K) or lower, and the FR-A846-01800(55K) or lower, and the sine wave filter (MT-BSL, MT-BSC) to the output side of the FR-A840-02160(75K) or higher, and the FR-A846-02160(75K) or higher.
- If the motor capacity is 280 kW or lower, connect the sine wave filter (MT-BSL/MT-BSC) to the output side of the FR-A842.

◆ With PM motor

Use the wiring length of 100 m or shorter when connecting a PM motor.

Use one PM motor for one inverter. Multiple PM motors cannot be connected to an inverter.

When the wiring length exceeds 50 m for a 400 V class motor driven by an inverter under PM sensorless vector control, set "9" (6 kHz) or less in Pr. 72 "PWM frequency selection".

CAUTION

- Especially for long-distance wiring, the inverter may be affected by a charging current caused by stray capacitances of the wiring, leading to an activation of the overcurrent protection, malfunction of the fast-response current limit operation, or even to an inverter failure. If the fast-response current limit function malfunctions, disable this function.
(For Pr. 156 "Stall prevention operation selection", refer to the FR-A800 Instruction Manual.)
- For details of Pr. 72 "PWM frequency selection", refer to the FR-A800 Instruction Manual.
- The optional surge voltage suppression filter FR-ASF-H and FR-BMF-H can be used under V/F control and Advanced magnetic flux vector control. The sine wave filter MT-BSL and MT-BSC can be used under V/F control. Do not use the filters under different control methods.
(For details, refer to the Instruction Manual of the option.)
- Refer to the FR-A800 Instruction Manual to drive a 400 V class motor by an inverter.
- The carrier frequency is limited during PM sensorless vector control. (Refer to the FR-A800 Instruction Manual.)

2.3.3 Cable size of the control circuit power supply (terminal R1/L11, S1/L21)

- Terminal screw size: M4
- Cable size: 0.75 mm² to 2 mm²
- Tightening torque: 1.5 Nm



2.4 Control circuit terminals

2.4.1 Terminal layout

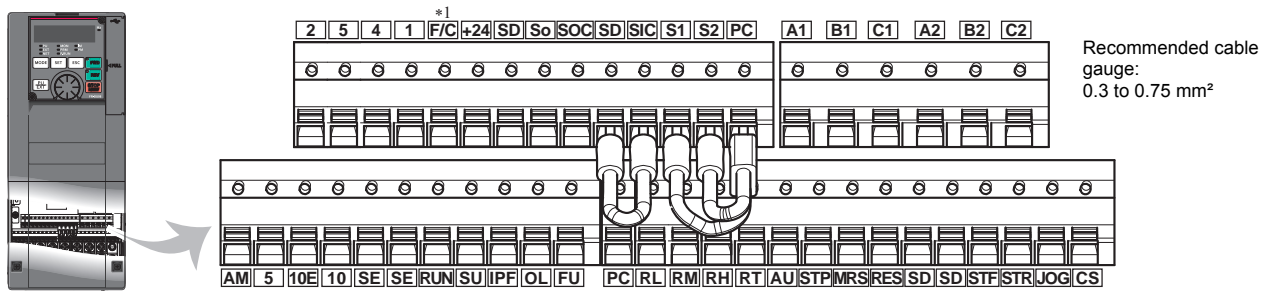

*1 The terminal functions as the terminal FM for the FM type, and as the terminal CA for the CA type.

2.4.2 Wiring method

• Power supply connection

For the control circuit wiring, strip off the sheath of a cable, and use it with a blade terminal. For a single wire, strip off the sheath of the wire and apply directly. Insert the blade terminal or the single wire into a socket of the terminal.

- Strip off the sheath for the below length. If the length of the sheath peeled is too long, a short circuit may occur with neighbouring wires. If the length is too short, wires might come off. Wire the stripped cable after twisting it to prevent it from becoming loose. In addition, do not solder it.

Cable sheath stripping length



- Insert wires into a blade terminal, then crimp the terminal. Insert wires to a blade terminal, and check that the wires come out for about 0 to 0.5 mm from a sleeve. Check the condition of the blade terminal after crimping. Do not use a blade terminal of which the crimping is inappropriate, or the face is damaged.

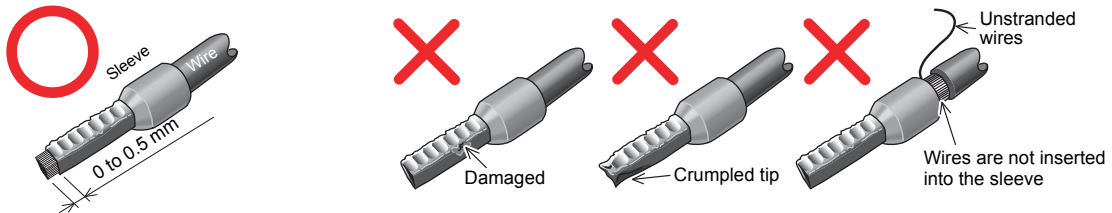

• Blade terminals commercially available (as of May 2016)

Cable gauge (mm ²)	Blade terminal model			Manufacturer	Crimping tool name
	With insulation sleeve	Without insulation sleeve	For UL wire *2		
0.3	AI 0,34-10TQ	—	—	Phoenix Contact Co., Ltd.	CRIMPFOX 6
0.5	AI 0,5-10WH	—	AI 0,5-10WH-GB		
0.75	AI 0,75-10GY	A 0,75-10	AI 0,75-10GY-GB		
1	AI 1-10RD	A 1-10	AI 1-10RD/1000GB		
1.25, 1.5	AI 1,5-10BK	A 1,5-10	AI 1,5-10BK/1000GB *3		
0.75 (for two wires)	AI-TWIN 2×0,75-10GY	—	—		

*2 A blade terminal with an insulation sleeve compatible with the MTW wire which has a thick wire insulation.

*3 Applicable for the terminals A1, B1, C1, A2, B2, and C2 only.

Cable gauge (mm ²)	Blade terminal product number	Insulation product number	Manufacturer	Crimping tool product number
0.3 to 0.75	BT 0.75-11	VC 0.75	NICHIFU Co.,Ltd.	NH 69

- (3) Insert the wires into a socket.

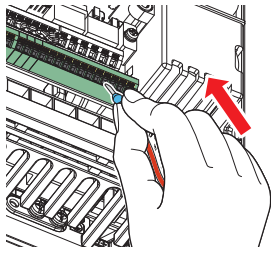

When using a single wire or stranded wires without a blade terminal, push the open/close button all the way down with a flathead screwdriver, and insert the wire.

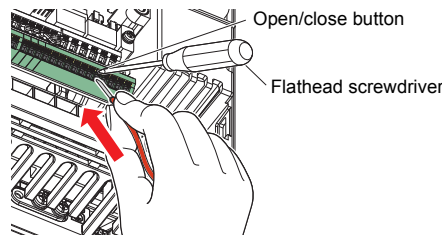

• Wire removal

Pull the wire while pushing the open/close button all the way down firmly with a flathead screwdriver.

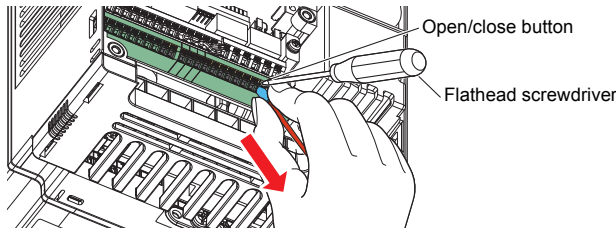

CAUTION

- When using stranded wires without a blade terminal, twist enough to avoid short circuit with a nearby terminals or wires.
- During wiring, pulling out the wire forcefully without pushing the open/close button all the way down may damage the terminal block.
- Use a small flathead screwdriver (tip thickness: 0.4 mm, tip width: 2.5 mm). If a flathead screwdriver with a narrow tip is used, terminal block may be damaged. Commercially available products (as of February 2016).

Name	Model	Manufacturer
Driver	SZF 0- 0,4 x 2,5	Phoenix Contact Co., Ltd.

- Place the flathead screwdriver vertical to the open/close button. In case the blade tip slips, it may cause an inverter damage or injury.

2.4.3 Wiring precautions

- It is recommended to use the cables of 0.3 to 0.75 mm² gauge for connection to the control circuit terminals.
- The wiring length should be 30 m (200 m for the terminal FM) maximum.
- Use two or more parallel micro-signal contacts or twin contacts to prevent a contact faults when using contact inputs since the control circuit input signals are micro-currents.
- To suppress EMI, use shielded or twisted cables for the control circuit terminals and run them away from the main and power circuits (including the 200 V relay sequence circuit). For the cables connected to the control circuit terminals, connect their shields to the common terminal of the connected control circuit terminal. When connecting an external power supply to the terminal PC, however, connect the shield of the power supply cable to the negative side of the external power supply. Do not directly earth the shield to the enclosure, etc.
- Always apply a voltage to the alarm output terminals (A1, B1, C1, A2, B2, C2) via a relay coil, lamp, etc.

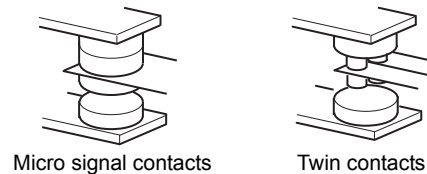



2.4.4 Control logic (sink/source) change

Change the control logic of input signals as necessary.

To change the control logic, change the jumper connector position on the control circuit board. Connect the jumper connector to the connector pin of the desired control logic.

- The control logic of input signals is initially set to the sink logic (SINK) for the FM type.
- The control logic of input signals is initially set to the source logic (SOURCE) for the CA type.

(The output signals may be used in either the sink or source logic independently of the jumper connector position.)

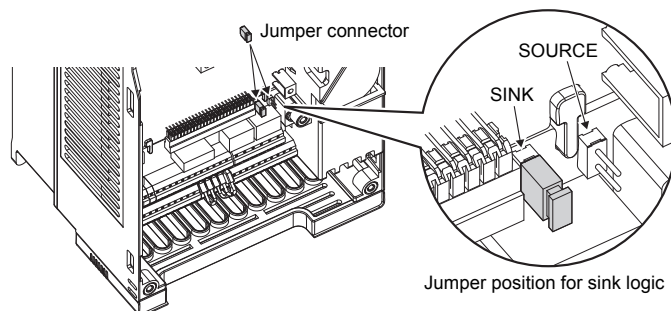

CAUTION

- Make sure that the jumper connector is installed correctly.
- Never change the control logic while power is ON.
- To change the control logic for the FR-A800-GF, remove the control circuit terminal block and change the jumper connector position. After changing the jumper connector position, reinstall the control circuit terminal block securely in place. For details on removing the control circuit terminal block refer to the FR-A800(-GF) Instruction Manual.

2.4.5 When supplying 24 V external power to the control circuit

Connect the 24 V external power supply across terminals +24 and SD. The 24 V external power supply enables I/O terminal ON/OFF operation, operation panel displays, control functions, and communication during communication operation even during power-OFF of inverter's main circuit power supply.

During the 24 V external power supply operation, "EV" flickers on the operation panel.

◆ Applied 24 V external power specification

Item	Rated specification
Input voltage	23 to 25.5 V DC
Input current	≤ 1.4 A

2.5 Safety stop function

2.5.1 Function description

The terminals related to the safety stop function are shown below.

Terminal symbol	Terminal function description			
S1 ^{*1}	For input of the safety stop	Channel 1	Between S1 and SIC	Open: In safety stop mode Short: Other than the safety stop mode
S2 ^{*1}		Channel 2	Between S2 and SIC	
SIC ^{*1}	Common terminal for terminals S1 and S2			
SO	Outputs when an alarm or failure is detected. The signal is output when no internal safety circuit failure ^{*2} exists.		OFF: Internal safety circuit failure ^{*2} ON: No internal safety circuit failure ^{*2}	
SOC	Terminal SO (open collector output) common			

^{*1} In the initial status, terminals S1 and PC, S2 and PC, and SIC and SD are respectively shorted with shorting wires. To use the safety stop function, remove all the shorting wires, and then connect to the safety relay module as shown in the following connection diagram.

^{*2} At an internal safety circuit failure, the operation panel displays one of the faults shown on the next page.

CAUTION

Use the terminal SO to output a fault and to prevent restarting of the inverter. The signal cannot be used as safety stop input signal to other devices.

2.5.2 Connection diagram

To prevent automatic restart after a fault occurrence, connect the reset button of a safety relay module or a safety programmable controller across the terminals SO and SOC. The reset button acts as the feedback input for the safety relay module or the safety programmable controller.

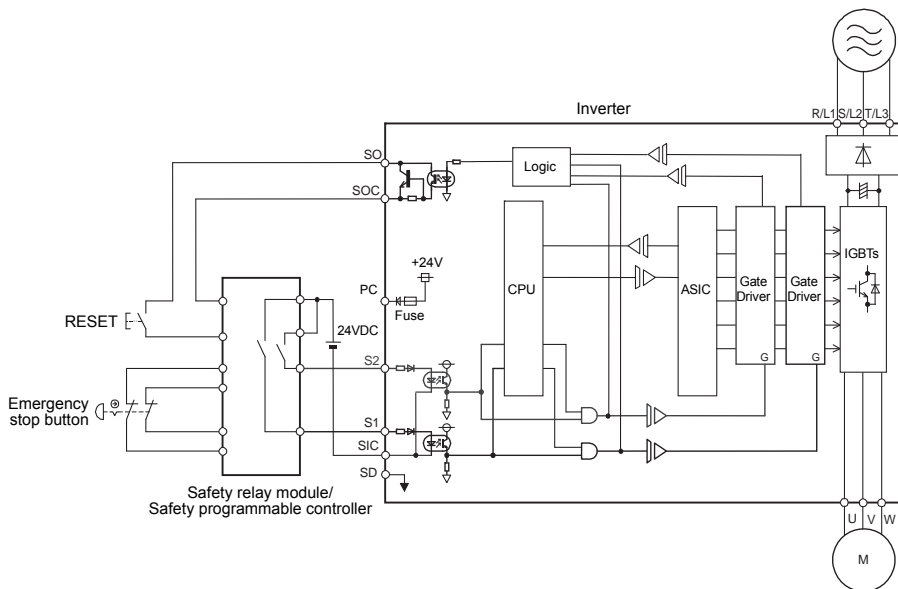



2.5.3 Safety stop function operation

Input power	Internal safety circuit status	Input terminal *1, *2		Output terminal	Output signal *8, *9	Inverter operation enable signal	Operation panel indication	
		S1	S2	SO	SAFE		E.SAF *6	SA *7
OFF	—	—	—	OFF	OFF	Output shutoff (Safe state)	Not displayed	Not displayed
ON	Normal	ON	ON	ON *3	OFF	Drive enabled	Not displayed	Not displayed
	Normal	ON	OFF	OFF *4	OFF *4	Output shutoff (Safe state)	Displayed	Displayed
	Normal	OFF	ON	OFF *4	OFF *4	Output shutoff (Safe state)	Displayed	Displayed
	Normal	OFF	OFF	ON *3	ON *3	Output shutoff (Safe state)	Not displayed	Displayed
	Fault	ON	ON	OFF	OFF	Output shutoff (Safe state)	Displayed	Not displayed *5
	Fault	ON	OFF	OFF	OFF	Output shutoff (Safe state)	Displayed	Displayed
	Fault	OFF	ON	OFF	OFF	Output shutoff (Safe state)	Displayed	Displayed
	Fault	OFF	OFF	OFF	OFF	Output shutoff (Safe state)	Displayed	Displayed

*1 ON: Transistor used for an open collector output is conducted.

OFF: Transistor used for an open collector output is not conducted.

*2 When not using the safety stop function, short across terminals S1 and PC, S2 and PC, and SIC and SD to use the inverter. (In the initial status, terminals S1 and PC, S2 and PC, and SIC and SD are respectively shorted with shorting wires.)

*3 If any of the protective functions shown in the following table is activated, the terminal SO and the SAFE output signal turn OFF.

Error definition	Operation panel indication
Option fault	E.OPT
Communication option fault	E.OP1 to E.OP3
Parameter storage device fault	E.PE
Retry count excess	E.RET
Parameter storage device fault	E.PE2
Operation panel power supply short circuit / RS-485 terminal power supply short circuit (FR-A800-E without RS-485 terminals)	E.CTE
24 VDC power fault	E.P24
Safety circuit fault	E.SAF
Overspeed occurrence	E.OS

Error definition	Operation panel indication
Speed deviation excess detection	E.OSD
Signal loss detection	E.ECT
Excessive position fault	E.OD
Brake sequence fault	E.MB1 to E.MB7
Encoder phase fault	E.EP
Magnetic pole position unknown	E.MP
CPU fault	E.CPU
	E.5 to E.7
Internal circuit fault	E.13

*4 If the internal safety circuit is operated normally, the terminal SO and the SAFE output signal remain ON until E.SAF is displayed, and the terminal SO and the SAFE output signal turn OFF when E.SAF is displayed.

*5 SA is displayed when the terminals S1 and S2 are identified as OFF due to the internal safety circuit failure.

*6 If another fault occurs at the same time as E.SAF, the other fault can be displayed.

*7 If another warning occurs at the same time as SA, the other warning can be displayed.

*8 The ON/OFF state of the output signal is the one for the positive logic. The ON and OFF are reversed for the negative logic.

To use the SAFE signal, set "80" (positive logic) or "180" (negative logic) in any of Pr. 190 to Pr. 196 (output terminal function selection) to assign the function.

*9 The use of the SAFE signal has not been certified for compliance with safety standards.

For more details, refer to the Safety stop function instruction manual.
(Find a PDF copy of this manual in the enclosed CD-ROM.)

3 FAILSAFE OF THE SYSTEM WHICH USES THE INVERTER

When a fault is detected by the protective function, the protective function activates and output a fault signal (ALM). However, a fault output signal may not be output at an inverter fault occurrence when the detection circuit or output circuit fails, etc. Although Mitsubishi Electric assures best quality products, provide an interlock which uses inverter status output signals to prevent accidents such as damage to machine when the inverter fails for some reason.

At the same time consider the system configuration where failsafe from outside the inverter, without using the inverter, is enabled even if the inverter fails.

Interlock method which uses the inverter status output signals

By combining the inverter status output signals to provide an interlock as shown below, an inverter alarm can be detected.

Interlock method	Check method	Used signals	Refer to
Inverter protective function operation	Operation check of an alarm contact Circuit error detection by negative logic	Fault output signal (ALM signal)	Refer to chapter "Parameter" of the FR-A800 Instruction Manual.
Inverter operating status	Operation ready signal check	Operation ready signal (RY signal)	
Inverter running status	Logic check of the start signal and running signal	Start signal (STF signal, STR signal) Running signal (RUN signal)	
	Logic check of the start signal and output current	Start signal (STF signal, STR signal) Output current detection signal (Y12 signal)	

Backup method outside the inverter

Even if the interlock is provided by the inverter status signal, enough failsafe is not ensured depending on the failure status of the inverter itself. For example, when the inverter CPU fails, even if the interlock is provided using the inverter fault output signal, start signal and RUN signal output, there is a case where a fault output signal is not output and RUN signal is kept output even if an inverter fault occurs.

Provide a speed detector to detect the motor speed and current detector to detect the motor current and consider the backup system such as checking up as below according to the level of importance of the system.

- Start signal and actual operation check

Check the motor running and motor current while the start signal is input to the inverter by comparing the start signal to the inverter and detected speed of the speed detector or detected current of the current detector. Note that the current is flowing through the motor while the motor coasts to stop, even after the inverter's start signal is turned OFF. For the logic check, configure a sequence considering the inverter deceleration time. In addition, it is recommended to check the three-phase current when using the current detector.

- Command speed and actual operation check

Check if there is no gap between the actual speed and commanded speed by comparing the inverter speed command and detected speed of the speed detector.

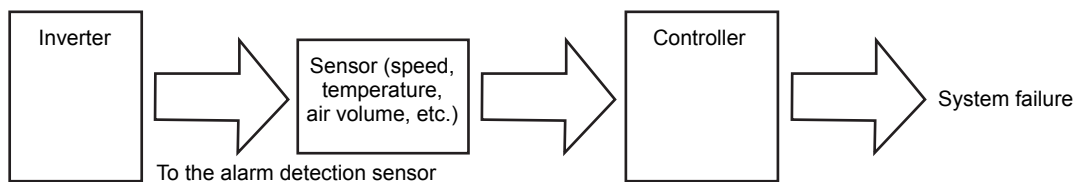

4 PRECAUTIONS FOR USE OF THE INVERTER

The FR-A800 series is a highly reliable product, but incorrect peripheral circuit making or operation/handling method may shorten the product life or damage the product.

Before starting operation, always recheck the following items:

- Use crimping terminals with insulation sleeve to wire the power supply and motor.
- Application of power to the output terminals (U, V, W) of the inverter will damage the inverter. Never perform such wiring.
- After wiring, wire offcuts must not be left in the inverter.
Wire offcuts can cause an alarm, failure or malfunction. Always keep the inverter clean. When drilling mounting holes in a control box etc., take care not to allow chips and other foreign matter to enter the inverter.
- Use cables of the appropriate size to make a voltage drop of 2% maximum.
If the wiring distance is long between the inverter and motor, a voltage drop in the main circuit will cause the motor torque to decrease especially at the output of a low frequency.
Refer to *page 26* for the recommended cable size.
- The overall wiring length should be within the prescribed length.
Especially for long distance wiring, the fast-response current limit function may be reduced or the equipment connected to the inverter output side may malfunction or become faulty under the influence of a charging current due to the stray capacity of the wiring. Therefore, note the overall wiring length. (Refer to *page 29*)
- Electromagnetic wave interference
The input/output (main circuit) of the inverter includes high frequency components, which may interfere with the communication devices (such as AM radios) used near the inverter. In this case, activate the EMC filter (turn ON the EMC filter ON/OFF connector) to minimize interference. (Refer to the Instruction Manual.)
- Electrical corrosion of the bearing
When a motor is driven by the inverter, axial voltage is generated on the motor shaft, which may cause electrical corrosion of the bearing in rare cases depending on the wiring, load, operating conditions of the motor or specific inverter settings (high carrier frequency and EMC filter ON).
Contact your sales representative to take appropriate countermeasures for the motor.
The following shows examples of countermeasures for the inverter:
 - Decrease the carrier frequency.
 - Turn OFF the EMC filter.
 - Provide a common mode choke on the output side of the inverter.*¹ (This is effective regardless of the EMC filter ON/OFF connector setting.)
^{*1} Recommended common mode choke: FT-3KM F series FINEMET® common mode choke cores manufactured by Hitachi Metals, Ltd. FINEMET is a registered trademark of Hitachi Metals, Ltd.
- Do not install a power factor correction capacitor, varistor or arrester on the inverter output side.
This will cause the inverter to trip or the capacitor, varistor, or arrester to be damaged. If any of the above devices is installed, immediately remove it.
- Before starting wiring or other work after the inverter is operated, wait for at least 10 minutes after the power supply has been switched off, and check that there are no residual voltage using a tester or the like. The capacitor is charged with high voltage for some time after power off and it is dangerous.
- If "EV" is displayed on the operation panel, turn OFF the 24 V external power supply before performing wiring.
- A short circuit or earth fault on the inverter output side may damage the inverter modules.
 - Fully check the insulation resistance of the circuit prior to inverter operation since repeated short circuits caused by peripheral circuit inadequacy or an earth fault caused by wiring inadequacy or reduced motor insulation resistance may damage the inverter modules.
 - Fully check the to-earth insulation and inter-phase insulation of the inverter output side before power-on.
Especially for an old motor or use in hostile atmosphere, securely check the motor insulation resistance etc.
- Do not use the inverter input side magnetic contactor (MC) to start/stop the inverter.
Since repeated inrush currents at power ON will shorten the life of the converter circuit (switching life is about 1,000,000 times), frequent starts and stops of the MC must be avoided.
Always use the start signal (ON/OFF of STF and STR signals) to start/stop the inverter.
- Standard models only: Across terminals P/+ and PR, connect only an external brake resistor.
Do not connect a mechanical brake.
- Do not apply a voltage higher than the permissible voltage to the inverter I/O signal circuits.
Contact to the inverter I/O signal circuits or opposite polarity may damage the I/O devices. Especially check the wiring to prevent the speed setting potentiometer from being connected incorrectly to short terminals 10E and 5.

- Provide electrical and mechanical interlocks for MC1 and MC2 which are used for commercial power supply-inverter switch-over.

When the wiring is incorrect or if there is a commercial power supply-inverter switch-over circuit as shown on the right, the inverter will be damaged by leakage current from the power supply due to arcs generated at the time of switch-over or chattering caused by a sequence error.

(The commercial power supply operation is not available with vector control dedicated motors (SF-V5RU, SF-THY) nor with PM motors.)

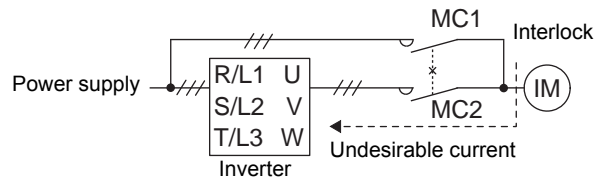

- If the machine must not be restarted when power is restored after a power failure, provide a magnetic contactor (MC) in the inverter's input side and also make up a sequence which will not switch on the start signal. If the start signal (start switch) remains on after a power failure, the inverter will automatically restart as soon as the power is restored.
- Vector control is available with an encoder-equipped motor. And such an encoder must be directly connected to a motor shaft without any backlash. (Real sensorless vector control, PM sensorless control do not require an encoder.)
- Inverter input side magnetic contactor (MC)

On the inverter input side, connect an MC for the following purposes. (Refer to the FR-A800 Instruction Manual.)

 - To release the inverter from the power supply when a fault occurs or when the drive is not functioning (e.g. emergency stop operation). For example (does not apply for FR-A842), MC avoids overheat or burnout of the brake resistor when heat capacity of the resistor is insufficient or brake regenerative transistor is damaged with short while connecting an optional brake resistor.
 - To prevent any accident due to an automatic restart at restoration of power after an inverter stop made by a power failure.
 - To separate the inverter from the power supply to ensure safe maintenance and inspection work.

If using an MC for emergency stop during operation, select an MC regarding the inverter input side current as JEM1038-AC-3 class rated current.
- Handling of inverter output side magnetic contactor

Switch the magnetic contactor between the inverter and motor only when both the inverter and motor are at a stop. When the magnetic contactor is turned ON while the inverter is operating, overcurrent protection of the inverter and such will activate. When MC is provided for switching to the commercial power supply, for example, switch it ON/OFF after the inverter and motor have stopped.

A PM motor is a synchronous motor with high-performance magnets embedded inside. High-voltage is generated at the motor terminals while the motor is running even after the inverter power is turned OFF. Before wiring or inspection, confirm that the motor is stopped. In an application, such as fan and blower, where the motor is driven by the load, a low-voltage manual contactor must be connected at the inverter's output side, and wiring and inspection must be performed while the contactor is open. Otherwise you may get an electric shock.
- Countermeasures against inverter-generated EMI

When the motor speed is unstable, due to change in the frequency setting signal caused by electromagnetic noises from the inverter, take the following measures when applying the motor speed by the analog signal:

 - Do not run the signal cables and power cables (inverter I/O cables) in parallel with each other and do not bundle them.
 - Run signal cables as far away as possible from power cables (inverter I/O cables).
 - Use shielded cables as signal cables.
 - Install a ferrite core on the signal cable (Example: ZCAT3035-1330 TDK).
- Instructions for overload operation

When performing operation of frequent start/stop of the inverter, increase/decrease in the temperature of the transistor element of the inverter may repeat due to a continuous flow of large current, shortening the life from thermal fatigue. Since thermal fatigue is related to the amount of current, the life can be increased by reducing bound current, starting current, etc. Decreasing current may increase the life. However, decreasing current will result in insufficient torque and the inverter may not start. Adding a margin to the current can eliminate such a condition. For a general-purpose motor, use an inverter of a higher capacity (up to 2 ranks). For a PM motor, use an inverter and a PM motor of higher capacities (up to 2 ranks).
- Make sure that the specifications and rating match the system requirements.
- FR-A842 models only: Connect the converter unit and the inverter correctly. For details refer to the FR-CC2 Instruction Manual.

5 BASIC OPERATION

5.1 Operation panel (FR-DU08, FR-DU08-01)

5.1.1 Components of the operation panel (FR-DU08, FR-DU08-01)

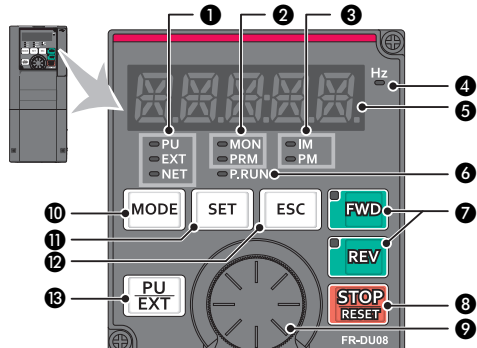

FR-DU08 (for FR-A800/A802 series)

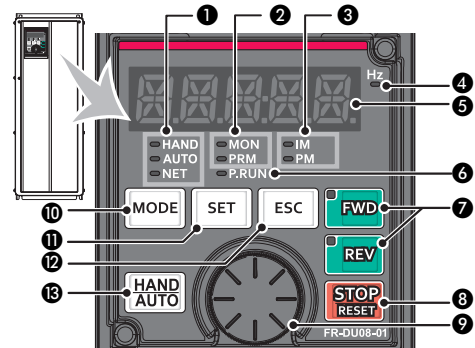

FR-DU08-01 (IP55 compatible model for FR-A806 series)

No.	Component	Name	Description
①		Operation mode indicator (FR-DU08)	PU (HAND for FR-DU08-01): Lit to indicate the PU operation mode. EXT (AUTO for FR-DU08-01): Lit to indicate the External operation mode. (Lit at power-ON in the initial setting.) NET: Lit to indicate the Network operation mode. PU and EXT (HAND and AUTO for FR-DU08-01): Lit to indicate the External/PU combined operation mode 1 or 2.
		Operation mode indicator (FR-DU08-01)	
②		Operation panel status indicator	MON: Lit to indicate the monitoring mode. Quickly flickers twice intermittently while the protective function is activated. Slowly flickers in the display-OFF mode. PRM: Lit to indicate the parameter setting mode.
③		Control motor indicator	IM: Lit to indicate the induction motor control. PM: Lit to indicate the PM sensorless vector control. The indicator flickers when test operation is selected.
④		Frequency unit indicator	Lit to indicate frequency. (Flickers when the set frequency is displayed in the monitor.)
⑤		Monitor (5-digit LED)	Shows the frequency, parameter number, etc. (Using Pr. 52, Pr. 774 to Pr. 776, the monitored item can be changed.)
⑥		PLC function indicator	Lit to indicate that the sequence program can be executed.
⑦		FWD key, REV key	FWD key: Starts forward rotation. The LED is lit during forward operation. REV key: Starts reverse rotation. The LED is lit during reverse operation. The LED flickers under the following conditions. <ul style="list-style-type: none"> • When the frequency command is not given even if the forward/reverse command is given. • When the frequency command is the starting frequency or lower. • When the MRS signal is being input.
		STOP/RESET key	
⑧		Setting dial	Stops the operation commands. Resets the inverter when the protection function is activated.
⑨		MODE key	The setting dial of the Mitsubishi Electric inverters. The setting dial is used to change the frequency and parameter settings. Press the setting dial to perform the following operations: <ul style="list-style-type: none"> • To display a set frequency in the monitoring mode (the setting can be changed using Pr. 992.) • To display the present setting during calibration • To display a fault history number in the faults history mode
⑩		SET key	Switches to different modes. Pressing the "MODE" and "PU/EXT (HAND/AUTO for FR-DU08-01)" keys simultaneously switches to the easy setting mode. Holding this key for 2 seconds locks the operation. The key lock is invalid when Pr. 161 = "0 (initial setting)". (Refer to the FR-A800 Instruction Manual.)
⑪		ESC key	Enters each setting. If pressed during operation, the monitored item changes. (Using Pr. 52 and Pr. 774–Pr. 776, the monitored item can be changed.) <div style="text-align: center;"> </div>
⑫		ESC key	Goes back to the previous display. Holding this key for a longer time changes the mode back to the monitor mode.
⑬		PU/EXT key (FR-DU08)	Switches between the PU operation mode, the PU JOG operation mode and the External operation mode. Pressing the "MODE" and "PU/EXT (HAND/AUTO for FR-DU08-01)" keys simultaneously switches to the easy setting mode. Cancels the PU stop also.
		HAND/AUTO key (FR-DU08-01)	

5.1.2 Basic operation (factory setting)

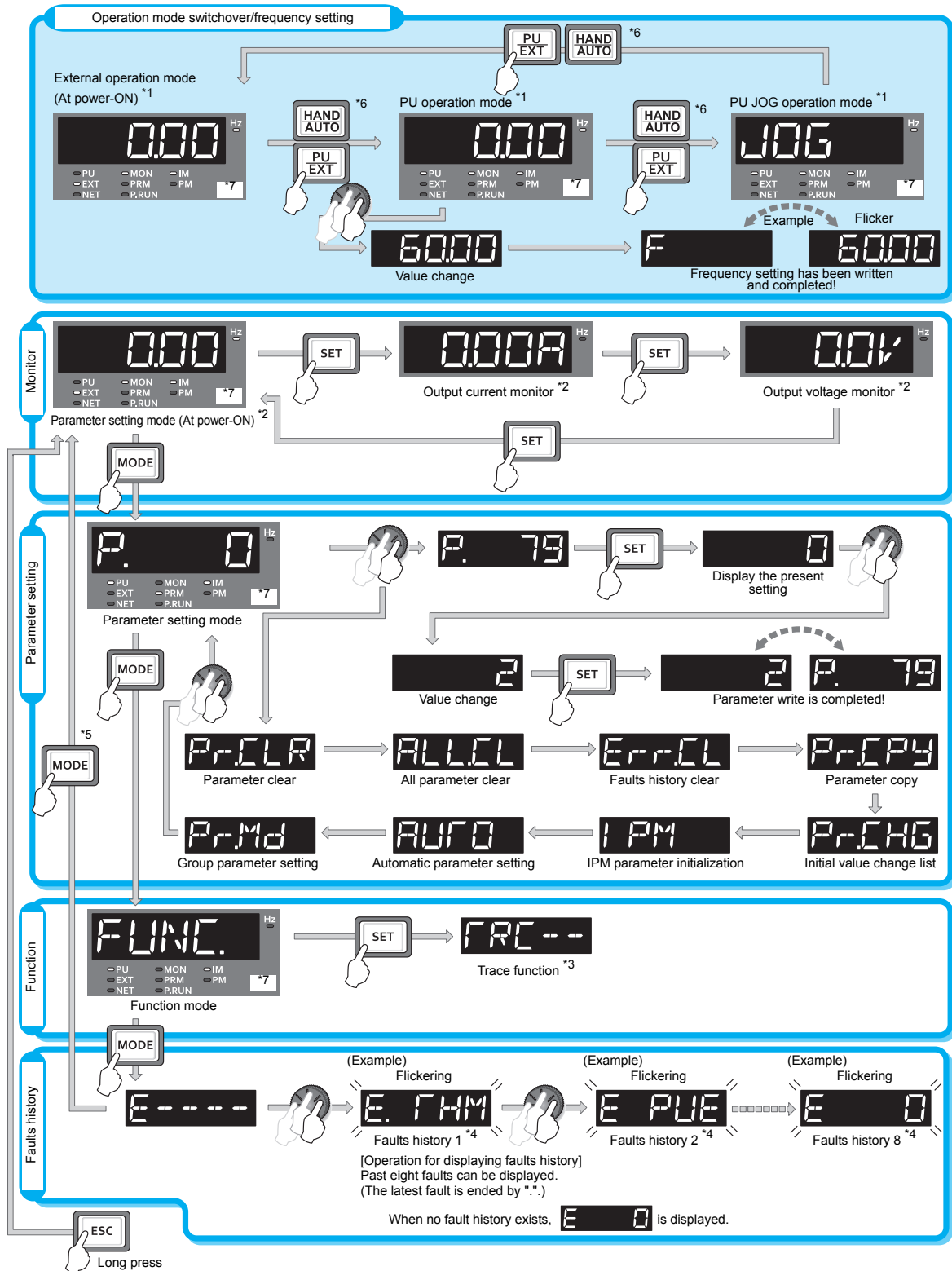

*1 For the details of operation modes, refer to the FR-A800 Instruction Manual.
 *2 Monitored items can be changed. (Refer to the FR-A800 Instruction Manual.)
 *3 For the details of the trace function, refer to the FR-A800 Instruction Manual.
 *4 For the details of faults history, refer to the FR-A800 Instruction Manual.
 *5 The USB memory mode will appear if a USB memory device is connected. Refer to the FR-A800 Instruction Manual for the USB memory mode.
 *6 HAND/AUTO key only when using FR-DU08-01.
 *7 Drawing features display of FR-DU08. LED displays of FR-DU08-01 for PU and EXT are different (HAND, AUTO), see previous page.



5.2 Parameter list

For simple variable-speed operation of the inverter, the initial values of the parameters may be used as they are. Set the necessary parameters to meet the load and operational specifications. Parameter setting, change and check can be performed from the operation panel (FR-DU08, resp. FR-DU08-01 for IP55 compatible models).

Remark

- **Simple** indicates simple mode parameters. Use Pr. 160 "User group read selection" to switch between the simple mode and extended mode (initially set to the extended mode).

Parameter	Name	Setting range	Initial value	Parameter	Name	Setting range	Initial value
0	Torque boost Simple	0 to 30%	6/4/3/2/ 1% *1	18	High speed maximum frequency	120 to 590 Hz	120 Hz *2 60 Hz *3
1	Maximum frequency Simple	0 to 120 Hz	120 Hz *2 60 Hz *3	19	Base frequency voltage	0 to 1000 V, 8888, 9999	9999/ 8888 *10
2	Minimum frequency Simple	0 to 120 Hz	0 Hz	20	Acceleration/ deceleration reference frequency	1 to 590 Hz	60/50 Hz *10
3	Base frequency Simple	0 to 590 Hz	60/50 Hz *10	21	Acceleration/ deceleration time increments	0, 1	0
4	Multi-speed setting (high speed) Simple	0 to 590 Hz	60/50 Hz *10	22	Stall prevention operation level (Torque limit level)	0 to 400%	150%
5	Multi-speed setting (middle speed) Simple	0 to 590 Hz	30 Hz	23	Stall prevention operation level compensation factor at double speed	0 to 200%, 9999	9999
6	Multi-speed setting (low speed) Simple	0 to 590 Hz	10 Hz	24 to 27	Multi-speed setting (4 speed to 7 speed)	0 to 590 Hz, 9999	9999
7	Acceleration time Simple	0 to 3600 s	5 s *4 15 s *5	28	Multi-speed input compensation selection	0, 1	0
8	Deceleration time Simple	0 to 3600 s	5 s *4 15 s *5	29	Acceleration/ deceleration pattern selection	0 to 6	0
9	Electronic thermal O/L relay Simple	0 to 500 *2 0 to 3600A *3	Inverter rated current	30	Regenerative function selection	0 to 2, 10, 11, 20, 21, 100 to 102, 110, 111, 120, 121/ 2, 10, 11, 102, 110, 111/ 0, 2, 10, 20, 100, 102, 110, 120 *15	0/10/0 *15
10	DC injection brake operation frequency	0 to 120 Hz, 9999	3 Hz	31	Frequency jump 1A	0 to 590 Hz, 9999	9999
11	DC injection brake operation time	0 to 10 s, 8888	0.5 s	32	Frequency jump 1B	0 to 590 Hz, 9999	9999
12	DC injection brake operation voltage	0 to 30%	4/2/1% *6	33	Frequency jump 2A	0 to 590 Hz, 9999	9999
13	Starting frequency	0 to 60 Hz	0.5 Hz	34	Frequency jump 2B	0 to 590 Hz, 9999	9999
14	Load pattern selection	0 to 5, 12 to 15	0				
15	Jog frequency	0 to 590 Hz	5 Hz				
16	Jog acceleration/ deceleration time	0 to 3600 s	0.5 s				
17	MRS input selection	0, 2, 4	0				

*1 Differs according to capacities.

- 6%: FR-A820-00046(0.4K) to 00077(0.75K) and FR-A840-00023(0.4K) to 00038(0.75K)
- 4%: FR-A820-00105(1.5K) to 00250(3.7K) and FR-A840-00052(1.5K) to 00126(3.7K)
- 3%: FR-A820-00340(5.5K), 00490(7.5K) and FR-A840-00170(5.5K), 00250(7.5K)
- 2%: FR-A820-00630(11K) to 03160(55K) and FR-A840-00310(11K) to 01800(55K)
- 1%: FR-A820-03800(75K) or higher and FR-A840-02160(75K) or higher

*2 For FR-A820-03160(55K) or lower and FR-A840-01800(55K) or lower

*3 For FR-A820-03800(75K) or higher and FR-A840-02160(75K) or higher

*4 For FR-A820-00490(7.5K) or lower and FR-A840-00250(7.5K) or lower

*5 For FR-A820-00630(11K) or higher and FR-A840-00310(11K) or higher

*6 Differs according to capacities.

- 4%: FR-A820-00490(7.5K) or lower and FR-A840-00250(7.5K) or lower
- 2%: FR-A820-00630(11K) to 03160(55K) and FR-A840-00310(11K) to 01800(55K)
- 1%: FR-A820-03800(75K) or higher and FR-A840-02160(75K) or higher

*10 Differs according to types. (FM type/CA type)

*15 Differs according to model types (standard model, separated converter type, IP55 compatible model).

Parameter	Name	Setting range	Initial value
35	Frequency jump 3A	0 to 590 Hz, 9999	9999
36	Frequency jump 3B	0 to 590 Hz, 9999	9999
37	Speed display	0, 1 to 9998	0
41	Up-to-frequency sensitivity	0 to 100%	10%
42	Output frequency detection	0 to 590 Hz	6 Hz
43	Output frequency detection for reverse rotation	0 to 590 Hz, 9999	9999
44	Second acceleration/deceleration time	0 to 3600 s	5 s
45	Second deceleration time	0 to 3600 s, 9999	9999
46	Second torque boost	0 to 30%, 9999	9999
47	Second V/F (base frequency)	0 to 590 Hz, 9999	9999
48	Second stall prevention operation level	0 to 400%	150%
49	Second stall prevention operation frequency	0 to 590 Hz, 9999	0 Hz
50	Second output frequency detection	0 to 590 Hz	30 Hz
51	Second electronic thermal O/L relay	0 to 500 A, 9999 * ² 0 to 3600 A, 9999 * ³	9999
52	Operation panel main monitor selection	0, 5 to 14, 17 to 20, 22 to 36, 38, 40 to 46, 50 to 57, 61, 62, 64, 67, 71 to 74, 87 to 98, 100	0
54	FM/CA terminal function selection * ¹⁰	1 to 3, 5 to 14, 17, 18, 21, 24, 32 to 34, 36, 46, 50, 52, 53, 61, 62, 67, 70, 87 to 90, 92, 93, 95, 97, 98	1
55	Frequency monitoring reference	0 to 590 Hz	60/50 Hz * ¹⁰
56	Current monitoring reference	0 to 500 A * ² 0 to 3600 A * ³	Inverter rated current
57	Restart coasting time	0, 0.1 to 30 s, 9999	9999
58	Restart cushion time	0 to 60 s	1 s
59	Remote function selection	0 to 3, 11 to 13	0
60	Energy saving control selection	0, 4, 9	0
61	Reference current	0 to 500 A, 9999 * ² 0 to 3600 A, 9999 * ³	9999

Parameter	Name	Setting range	Initial value
62	Reference value at acceleration	0 to 400%, 9999	9999
63	Reference value at deceleration	0 to 400%, 9999	9999
64	Starting frequency for elevator mode	0 to 10 Hz, 9999	9999
65	Retry selection	0 to 5	0
66	Stall prevention operation reduction starting frequency	0 to 590 Hz	60/50 Hz * ¹⁰
67	Number of retries at fault occurrence	0 to 10, 101 to 110	0
68	Retry waiting time	0.1 to 600 s	1 s
69	Retry count display erase	0	0
70* ¹³	Special regenerative brake duty	0 to 100%	0%
71	Applied motor	0 to 6, 13 to 16, 20, 23, 24, 30, 33, 34, 40, 43, 44, 50, 53, 54, 70, 73, 74, 330, 333, 334, 8090, 8093, 8094, 9090, 9093, 9094	0
72	PWM frequency selection	0 to 15 * ² 0 to 6, 25 * ³	2
73	Analog input selection	0 to 7, 10 to 17	1
74	Input filter time constant	0 to 8	1
75	Reset selection/disconnected PU detection/PU stop selection	0 to 3, 14 to 17 * ² 0 to 3, 14 to 17, 100 to 103, 114 to 117 * ³	14
76	Fault code output selection	0 to 2	0
77	Parameter write selection	0 to 2	0
78	Reverse rotation prevention selection	0 to 2	0
79	Operation mode selection <i>Simple</i>	0 to 4, 6, 7	0
80	Motor capacity	0.4 to 55 kW, 9999 * ² 0 to 3600 kW, 9999 * ³	9999
81	Number of motor poles	2, 4, 6, 8, 10, 12, 9999	9999
82	Motor excitation current	0 to 500 A, 9999 * ² 0 to 3600 A, 9999 * ³	9999
83	Rated motor voltage	0 to 1000 V	200/ 400 V * ⁷
84	Rated motor frequency	10 to 400 Hz, 9999	9999

*² For FR-A820-03160(55K) or lower and FR-A840-01800(55K) or lower

*³ For FR-A820-03800(75K) or higher and FR-A840-02160(75K) or higher

*⁷ Differs according to the voltage class. (200 V class/400 V class)

*¹⁰ Differs according to types. (FM type/CA type)

*¹³ Setting available for standard models only.



Parameter	Name	Setting range	Initial value
85	Excitation current break point	0 to 400 Hz, 9999	9999
86	Excitation current low speed scaling factor	0 to 300%	9999
89	Speed control gain (Advanced magnetic flux vector)	0 to 200%, 9999	9999
90	Motor constant (R1)	0 to 50 Ω, 9999 ^{*2}	9999
		0 to 400 mΩ, 9999 ^{*3}	
91	Motor constant (R2)	0 to 50 Ω, 9999 ^{*2}	9999
		0 to 400 mΩ, 9999 ^{*3}	
92	Motor constant (L1)/ d-axis inductance (Ld)	0 to 6000 mH, 9999 ^{*2}	9999
		0 to 400 mH, 9999 ^{*3}	
93	Motor constant (L2)/ q-axis inductance (Lq)	0 to 6000 mH, 9999 ^{*2}	9999
		0 to 400 mH, 9999 ^{*3}	
94	Motor constant (X)	0 to 100%, 9999	9999
95	Online auto tuning selection	0 to 2	0
96	Auto tuning setting/status	0, 1, 11, 101	0
100	V/F1 (first frequency)	0 to 590 Hz, 9999	9999
101	V/F1 (first frequency voltage)	0 to 1000 V	0 V
102	V/F2 (second frequency)	0 to 590 Hz, 9999	9999
103	V/F2 (second frequency voltage)	0 to 1000 V	0 V
104	V/F3 (third frequency)	0 to 590 Hz, 9999	9999
105	V/F3 (third frequency voltage)	0 to 1000 V	0 V
106	V/F4 (fourth frequency)	0 to 590 Hz, 9999	9999
107	V/F4 (fourth frequency voltage)	0 to 1000 V	0 V
108	V/F5 (fifth frequency)	0 to 590 Hz, 9999	9999
109	V/F5 (fifth frequency voltage)	0 to 1000 V	0 V
110	Third acceleration/ deceleration time	0 to 3600 s, 9999	9999
111	Third deceleration time	0 to 3600 s, 9999	9999
112	Third torque boost	0 to 30%, 9999	9999
113	Third V/F (base frequency)	0 to 590 Hz, 9999	9999
114	Third stall prevention operation level	0 to 400%	150%
115	Third stall prevention operation frequency	0 to 590 Hz	0 Hz

Parameter	Name	Setting range	Initial value
116	Third output frequency detection	0 to 590 Hz	60/50 Hz ^{*10}
117	PU communication station number	0 to 31	0
118	PU communication speed	48, 96, 192, 384, 576, 768, 1152	192
119	PU communication stop bit length / data length	0, 1, 10, 11	1
120	PU communication parity check	0 to 2	2
121	Number of PU communication retries	0 to 10, 9999	1
122	PU communication check time interval	0, 0.1 to 999.8 s, 9999	9999
123	PU communication waiting time setting	0 to 150 ms, 9999	9999
124	PU communication CR/LF selection	0 to 2	1
125	Terminal 2 frequency setting gain frequency Simple	0 to 590 Hz	60/50 Hz ^{*10}
126	Terminal 4 frequency setting gain frequency Simple	0 to 590 Hz	60/50 Hz ^{*10}
127	PID control automatic switchover frequency	0 to 590 Hz, 9999	9999
128	PID action selection	0, 10, 11, 20, 21, 40 to 43, 50, 51, 60, 61, 70, 71, 80, 81, 90, 91, 100, 101, 1000, 1001, 1010, 1011, 2000, 2001, 2010, 2011	0
129	PID proportional band	0.1 to 1000%, 9999	100%
130	PID integral time	0.1 to 3600 s, 9999	1 s
131	PID upper limit	0 to 100%, 9999	9999
132	PID lower limit	0 to 100%, 9999	9999
133	PID action set point	0 to 100%, 9999	9999
134	PID differential time	0.01 to 10.00 s, 9999	9999
135	Electronic bypass sequence selection	0, 1	0
136	MC switchover interlock time	0 to 100 s	1 s
137	Start waiting time	0 to 100 s	0.5 s
138	Bypass selection at a fault	0, 1	0
139	Automatic switchover frequency between inverter and commercial power-supply operation	0 to 60 Hz, 9999	9999

^{*2} For FR-A820-03160(55K) or lower and FR-A840-01800(55K) or lower

^{*3} For FR-A820-03800(75K) or higher and FR-A840-02160(75K) or higher

^{*10} Differs according to types. (FM type/CA type)

Parameter	Name	Setting range	Initial value
140	Backlash acceleration stopping frequency	0 to 590 Hz	1 Hz
141	Backlash acceleration stopping time	0 to 360 s	0.5 s
142	Backlash deceleration stopping frequency	0 to 590 Hz	1 Hz
143	Backlash deceleration stopping time	0 to 360 s	0.5 s
144	Speed setting switchover	0, 2, 4, 6, 8, 10, 102, 104, 106, 108, 110, 112	4
145	PU display language selection	0 to 7	—
147	Acceleration/ deceleration time switching frequency	0 to 590 Hz, 9999	9999
148	Stall prevention level at 0V input	0 to 400%	150%
149	Stall prevention level at 10V input	0 to 400%	200%
150	Output current detection level	0 to 400%	150%
151	Output current detection signal delay time	0 to 10 s	0 s
152	Zero current detection level	0 to 400%	5%
153	Zero current detection time	0 to 10 s	0.5 s
154	Voltage reduction selection during stall prevention operation	0, 1, 10, 11	1
155	RT signal function validity condition selection	0, 10	0
156	Stall prevention operation selection	0 to 31, 100, 101	0
157	OL signal output timer	0 to 25 s, 9999	0 s
158	AM terminal function selection	1 to 3, 5 to 14, 17, 18, 21, 24, 32 to 34, 36, 46, 50, 52 to 54, 61, 62, 67, 70, 87 to 90, 91 to 98	1
159	Automatic switch-over frequency range from bypass to inverter operation	0 to 10 Hz, 9999	9999
160	User group read selection <i>Simple</i>	0, 1, 9999	0
161	Frequency setting/ key lock operation selection	0, 1, 10, 11	0
162	Automatic restart after instantaneous power failure selection	0 to 3, 10 to 13	0
163	First cushion time for restart	0 to 20 s	0 s

Parameter	Name	Setting range	Initial value
164	First cushion voltage for restart	0 to 100%	0%
165	Stall prevention operation level for restart	0 to 400%	150%
166	Output current detection signal retention time	0 to 10 s, 9999	0.1 s
167	Output current detection operation selection	0, 1, 10, 11	0
168	Parameter for manufacturer setting. Do not make setting.		
169			
170	Watt-hour meter clear	0, 10, 9999	9999
171	Operation hour meter clear	0, 9999	9999
172	User group registered display/ batch clear	9999, (0 to 16)	0
173	User group registration	0 to 1999, 9999	9999
174	User group clear	0 to 1999, 9999	9999
178	STF terminal function selection	0 to 20, 22 to 28, 37, 42 to 48, 50 to 53, 57 to 60, 62, 64 to 74, 76 to 80, 87, 92 to 96, 9999	60
179	STR terminal function selection	0 to 20, 22 to 28, 37, 42 to 48, 50 to 53, 57 to 59, 61, 62, 64 to 74, 76 to 80, 87, 92 to 96, 9999	61
180	RL terminal function selection	0 to 20, 22 to 28, 37, 42 to 48, 50 to 53, 57 to 59, 62, 64 to 74, 76 to 80, 87, 92 to 96, 9999	0
181	RM terminal function selection		1
182	RH terminal function selection		2
183	RT terminal function selection		3
184	AU terminal function selection		4
185	JOG terminal function selection		5
186	CS terminal function selection		6
187	MRS terminal function selection		24/ 10/24 ^{*15}
188	STOP terminal function selection		25
189	RES terminal function selection		62

*15 Differs according to model types (standard model, separated converter type, IP55 compatible model).



Parameter	Name	Setting range	Initial value
190	RUN terminal function selection	0 to 8, 10 to 20, 22, 25 to 28, 30 to 36,	0
191	SU terminal function selection	38 to 57, 60, 61, 63, 64, 67, 68, 70, 79, 80, 84,	1
192	IPF terminal function selection	85, 90 to 99, 100 to 108, 110 to 116, 120, 122, 125 to 128, 130 to 136,	2/ 9999/2 *15
193	OL terminal function selection	138 to 157, 160, 161, 163, 164, 167, 168, 170, 179, 180, 184, 185, 190 to 199, 200 to 208, 242*19, 300 to 308, 342*19, 9999	3
194	FU terminal function selection	110 to 116, 120, 122, 125 to 128, 130 to 136, 138 to 157, 160, 161, 163, 164, 167, 168, 170, 179, 180, 184, 185, 190 to 199, 200 to 208, 242*19, 300 to 308, 342*19, 9999	4
195	ABC1 terminal function selection	0 to 8, 10 to 20, 22, 25 to 28, 30 to 36, 38 to 57, 60, 61, 63, 64, 67, 68, 70, 79, 80, 84, 85, 90, 91, 94 to 99, 100 to 108, 110 to 116, 120, 122, 125 to 128, 130 to 136, 138 to 157, 160, 161, 163, 164, 167, 168, 170, 179, 180, 184, 185, 190, 191, 194 to 199, 200 to 208, 242*19, 300 to 308, 342*19, 9999	99
196	ABC2 terminal function selection	110 to 116, 120, 122, 125 to 128, 130 to 136, 138 to 157, 160, 161, 163, 164, 167, 168, 170, 179, 180, 184, 185, 190, 191, 194 to 199, 200 to 208, 242*19, 300 to 308, 342*19, 9999	9999
232 to 239	Multi-speed setting (speeds 8 to 15)	0 to 590 Hz, 9999	9999
240	Soft-PWM operation selection	0, 1	1
241	Analog input display unit switchover	0, 1	0
242	Terminal 1 added compensation amount (terminal 2)	0 to 100%	100%
243	Terminal 1 added compensation amount (terminal 4)	0 to 100%	75%
244	Cooling fan operation selection	0, 1, 101 to 105	1
245	Rated slip	0 to 50%, 9999	9999
246	Slip compensation time constant	0.01 to 10 s	0.5 s
247	Constant-power range slip compensation selection	0, 9999	9999
248	Self power management selection	0 to 2	0
249	Earth fault detection at start	0, 1	0

Parameter	Name	Setting range	Initial value
250	Stop selection	0 to 100 s, 1000 to 1100 s, 8888, 9999	9999
251	Output phase loss protection selection	0, 1	1
252	Override bias	0 to 200%	50%
253	Override gain	0 to 200%	150%
254	Main circuit power OFF waiting time	1 to 3600 s, 9999	600 s
255	Life alarm display	(0 to 15)	0
256 *14	Inrush current limit circuit life display	(0 to 100%)	100%
257	Control circuit capacitor life display	(0 to 100%)	100%
258 *14	Main circuit capacitor life display	(0 to 100%)	100%
259 *14	Main circuit capacitor life measuring	0, 1	0
260	PWM frequency automatic switchover	0, 1	1
261	Power failure stop selection	0 to 2, 21, 22	0
262	Subtracted frequency at deceleration start	0 to 20 Hz	3 Hz
263	Subtraction starting frequency	0 to 590 Hz, 9999	60/50 Hz *10
264	Power-failure deceleration time 1	0 to 3600 s	5 s
265	Power-failure deceleration time 2	0 to 3600 s, 9999	9999
266	Power failure deceleration time switchover frequency	0 to 590 Hz	60/50 Hz *10
267	Terminal 4 input selection	0 to 2	0
268	Monitor decimal digits selection	0, 1, 9999	9999
269	Parameter for manufacturer setting. Do not make setting.		
270	Stop-on contact/load torque high-speed frequency control selection	0 to 3, 11, 13	0
271	High-speed setting maximum current	0 to 400%	50%
272	Middle-speed setting minimum current	0 to 400%	100%
273	Current averaging range	0 to 590 Hz, 9999	9999

*10 Differs according to types. (FM type/CA type)

*14 Setting available for standard models and IP55 compatible models.

*15 Differs according to model types (standard model, separated converter type, IP55 compatible model).

*19 The setting is available for the FR-A800-E or when a compatible plug-in option is installed.

Parameter	Name	Setting range	Initial value	Parameter	Name	Setting range	Initial value
274	Current averaging filter time constant	1 to 4000	16	298	Frequency search gain	0 to 32767, 9999	9999
275	Stop-on contact excitation current low-speed multiplying factor	50 to 300%, 9999	9999	299	Rotation direction detection selection at restarting	0, 1, 9999	9999
276	PWM carrier frequency at stop-on contact	0 to 9, 9999 * ² 0 to 4, 9999 * ³	9999	313 * ¹⁸ , * ¹⁹	DO0 output selection	0 to 8, 10 to 20, 22, 25 to 28, 30 to 36, 38 to 57, 60, 61, 63, 64, 68, 70, 79, 84 to 99, 100 to 108, 110 to 116, 120, 122, 125 to 128, 130 to 136, 138 to 157, 160, 161, 163, 164, 168, 170, 179, 184 to 199, 200 to 208, 242 * ¹⁹ , 300 to 308, 342 * ¹⁹ , 9999	9999
278	Brake opening frequency	0 to 30 Hz	3 Hz	314 * ¹⁸ , * ¹⁹	DO1 output selection	0 to 8, 10 to 20, 22, 25 to 28, 30 to 36, 38 to 57, 60, 61, 63, 64, 68, 70, 79, 84 to 99, 100 to 108, 110 to 116, 120, 122, 125 to 128, 130 to 136, 138 to 157, 160, 161, 163, 164, 168, 170, 179, 184 to 199, 200 to 208, 242 * ¹⁹ , 300 to 308, 342 * ¹⁹ , 9999	9999
279	Brake opening current	0 to 400%	130%	315 * ¹⁸ , * ¹⁹	DO2 output selection	0 to 8, 10 to 20, 22, 25 to 28, 30 to 36, 38 to 57, 60, 61, 63, 64, 68, 70, 79, 84 to 99, 100 to 108, 110 to 116, 120, 122, 125 to 128, 130 to 136, 138 to 157, 160, 161, 163, 164, 168, 170, 179, 184 to 199, 200 to 208, 242 * ¹⁹ , 300 to 308, 342 * ¹⁹ , 9999	9999
280	Brake opening current detection time	0 to 2 s	0.3 s	331	RS-485 communication station	0 to 31 (0 to 247)	0
281	Brake operation time at start	0 to 5 s	0.3 s	332	RS-485 communication speed	3, 6, 12, 24, 48, 96, 192, 384, 576, 768, 1152	96
282	Brake operation frequency	0 to 30 Hz	6 Hz	333	RS-485 communication stop bit length/data length	0, 1, 10, 11	1
283	Brake operation time at stop	0 to 5 s	0.3 s	334	RS-485 communication parity check selection	0 to 2	2
284	Deceleration detection function selection	0, 1	0	335	RS-485 communication retry count	0 to 10, 9999	1
285	Overspeed detection frequency (Excessive speed deviation detection frequency)	0 to 30 Hz, 9999	9999	336	RS-485 communication check time interval	0 to 999.8 s, 9999	0 s
286	Droop gain	0 to 100%	0%	337	RS-485 communication waiting time setting	0 to 150 ms, 9999	9999
287	Droop filter time constant	0 to 1 s	0.3 s	338	Communication operation command source	0, 1	0
288	Droop function activation selection	0 to 2, 10, 11	0	339	Communication speed command source	0 to 2	0
289	Inverter output terminal filter	5 to 50 ms, 9999	9999	340	Communication startup mode selection	0 to 2, 10, 12	0
290	Monitor negative output selection	0 to 7	0	341	RS-485 communication CR/LF selection	0 to 2	1
291	Pulse train I/O selection	0, 1, 10, 11, 20, 21, 100 (FM type) 0,1 (CA type)	0	342	Communication EEPROM write selection	0, 1	0
292	Automatic acceleration/ deceleration	0, 1, 3, 5 to 8, 11	0	343	Communication error count	—	0
293	Acceleration/ deceleration separate selection	0 to 2	0	349 * ¹⁸ , * ¹⁹	Communication reset selection	0, 1	0
294	UV avoidance voltage gain	0 to 200%	100%	350 * ¹²	Stop position command selection	0, 1, 9999	9999
295	Frequency change increment amount setting	0, 0.01, 0.10, 1.00, 10.00	0	351 * ¹²	Orientation speed	0 to 30 Hz	2 Hz
296	Password lock level	0 to 6, 99, 100 to 106, 199, 9999	9999	352 * ¹²	Creep speed	0 to 10 Hz	0.5 Hz
297	Password lock/ unlock	(0 to 5), 1000 to 9998, 9999	9999	353 * ¹²	Creep switchover position	0 to 16383	511

*² For FR-A820-03160(55K) or lower and FR-A840-01800(55K) or lower*³ For FR-A820-03800(75K) or higher and FR-A840-02160(75K) or higher*¹² The setting is available only when a vector control compatible option is installed.*¹⁸ The setting is available only for the FR-A800-GF or when a compatible plug-in option is installed.*¹⁹ The setting is available for the FR-A800-E or when a compatible plug-in option is installed.



Parameter	Name	Setting range	Initial value
354 *12	Position loop switchover position	0 to 8191	96
355 *12	DC injection brake start position	0 to 255	5
356 *12	Internal stop position command	0 to 16383	0
357 *12	Orientation in-position zone	0 to 255	5
358 *12	Servo torque selection	0 to 13	1
359 *8	Encoder rotation direction	0, 1, 100, 101	1
360 *12	16-bit data selection	0 to 127	0
361 *12	Position shift	0 to 16383	0
362 *12	Orientation position loop gain	0.1 to 100	1
363 *12	Completion signal output delay time	0 to 5 s	0.5 s
364 *12	Encoder stop check time	0 to 5 s	0.5 s
365 *12	Orientation limit	0 to 60 s, 9999	9999
366 *12	Recheck time	0 to 5 s, 9999	9999
367 *12	Speed feedback range	0 to 590 Hz, 9999	9999
368 *12	Feedback gain	0 to 100	1
369 *8	Number of encoder pulses	0 to 4096	1024
374	Overspeed detection level	0 to 590 Hz, 9999	9999
376 *8	Encoder signal loss detection enable/disable selection	0, 1	0
380	Acceleration S-pattern 1	0 to 50%	0
381	Deceleration S-pattern 1	0 to 50%	0
382	Acceleration S-pattern 2	0 to 50%	0
383	Deceleration S-pattern 2	0 to 50%	0
384	Input pulse division scaling factor	0 to 250	0
385	Frequency for zero input pulse	0 to 590 Hz	0
386	Frequency for maximum input pulse	0 to 590 Hz	60/50 Hz *10
393 *12	Orientation selection	0 to 2, 10 to 12	0
394 *12	Number of machine side gear teeth	0 to 32767	1
395 *12	Number of motor side gear teeth	0 to 32767	1
396 *12	Orientation speed gain (P term)	0 to 1000	60
397 *12	Orientation speed integral time	0 to 20 s	0.333 s

Parameter	Name	Setting range	Initial value
398 *12	Orientation speed gain (D term)	0 to 100	1
399 *12	Orientation deceleration ratio	0 to 1000	20
414	PLC function operation selection	0 to 2	0
415	Inverter operation lock mode setting	0, 1	0
416	Pre-scale function selection	0 to 5	0
417	Pre-scale setting value	0 to 32767	1
419	Position command source selection	0, 1, 2, 10, 100, 110, 1110	0
420	Command pulse scaling factor numerator (electronic gear numerator)	1 to 32767	1
421	Command pulse multiplication denominator (electronic gear denominator)	1 to 32767	1
422	Position control gain	0 to 150 s ⁻¹	25 s ⁻¹
423	Position feed forward gain	0 to 100%	0%
424	Position command acceleration/deceleration time constant	0 to 50 s	0 s
425	Position feed forward command filter	0 to 5 s	0 s
426	In-position width	0 to 32767 pulse	100 pulse
427	Excessive level error	0 to 400K pulse, 9999	40K pulse
428	Command pulse selection	0 to 5	0
429	Clear signal selection	0, 1	1
430	Pulse monitor selection	0 to 5, 12, 13, 100 to 105, 112, 113, 1000 to 1005, 1012, 1013, 1100 to 1105, 1112, 1113, 8888, 9999	9999
434 *18	Network number (CC-Link IE)	0 to 255	0
435 *18	Station number (CC-Link IE)	0 to 255	0
446	Model position control gain	0 to 150 s ⁻¹	25 s ⁻¹
450	Second applied motor	0, 1, 3 to 6, 13 to 16, 20, 23, 24, 30, 33, 34, 40, 43, 44, 50, 53, 54, 70, 73, 74, 330, 333, 334, 8090, 8093, 8094, 9090, 9093, 9094, 9999	9999

*8 The setting is available only when the FR-A8AP, FR-A8APR oder FR-A8TP is mounted.

*10 Differs according to types. (FM type/CA type)

*12 The setting is available only when a vector control compatible option is mounted.

*18 The setting is available only for the FR-A800-GF or when a compatible plug-in option is installed.

Parameter	Name	Setting range	Initial value	Parameter	Name	Setting range	Initial value
451	Second motor control method selection	0 to 6, 10 to 14, 20, 100 to 106, 110 to 114, 9999	9999	473	Fifth target position lower 4 digits	0 to 9999	0
453	Second motor capacity	0.4 to 55 kW, 9999 ^{*2} 0 to 3600 kW, 9999 ^{*3}	9999	474	Fifth target position upper 4 digits		0
454	Number of second motor poles	2, 4, 6, 8, 10, 12, 9999	9999	475	Sixth target position lower 4 digits		0
455	Second motor excitation current	0 to 500 A, 9999 ^{*2} 0 to 3600 A, 9999 ^{*3}	9999	476	Sixth target position upper 4 digits		0
456	Rated second motor voltage	0 to 1000 V	200/ 400 V ^{*7}	477	Seventh target position lower 4 digits		0
457	Rated second motor frequency	10 to 400 Hz, 9999	9999	478	Seventh target position upper 4 digits		0
458	Second motor constant (R1)	0 to 50 Ω, 9999 ^{*2} 0 to 400 mΩ, 9999 ^{*3}	9999	479	Eighth target position lower 4 digits		0
459	Second motor constant (R2)	0 to 50 Ω, 9999 ^{*2} 0 to 400 mΩ, 9999 ^{*3}	9999	480	Eighth target position upper 4 digits		0
460	Second motor constant(L1)/Second motor d-axis inductance (Ld)	0 to 6000 mH, 9999 ^{*2} 0 to 400 mH, 9999 ^{*3}	9999	481	Ninth target position lower 4 digits		0
461	Second motor constant (L2)/Second motor q-axis inductance (Lq)	0 to 6000 mH, 9999 ^{*2} 0 to 400 mH, 9999 ^{*3}	9999	482	Ninth target position upper 4 digits		0
462	Second motor constant (X)	0 to 100%, 9999	9999	483	Tenth target position lower 4 digits		0
463	Second motor auto tuning setting/status	0, 1, 11, 101	0	484	Tenth target position upper 4 digits		0
464	Digital position control sudden stop deceleration time	0 to 360 s	0	485	Eleventh target position lower 4 digits		0
465	First target position lower 4 digits	0 to 9999	0	486	Eleventh target position upper 4 digits		0
466	First target position upper 4 digits		0	487	Twelfth target position lower 4 digits		0
467	Second target position lower 4 digits		0	488	Twelfth target position upper 4 digits		0
468	Second target position upper 4 digits		0	489	Thirteenth target position lower 4 digits		0
469	Third target position lower 4 digits		0	490	Thirteenth target position upper 4 digits		0
470	Third target position upper 4 digits		0	491	Fourteenth target position lower 4 digits		0
471	Fourth target position lower 4 digits		0	492	Fourteenth target position upper 4 digits		0
472	Fourth target position upper 4 digits		0	493	Fifteenth target position lower 4 digits	0	
				494	Fifteenth target position upper 4 digits	0	
				495	Remote output selection	0, 1, 10, 11	0

^{*2} For FR-A820-03160(55K) or lower and FR-A840-01800(55K) or lower

^{*3} For FR-A820-03800(75K) or higher and FR-A840-02160(75K) or higher

^{*7} Differs according to the voltage class. (200 V class/400 V class)



Parameter	Name	Setting range	Initial value
496	Remote output data 1	0 to 4095	0
497	Remote output data 2	0 to 4095	0
498	PLC function flash memory clear	0 to 9999	0
500 ^{*18}	Communication error execution waiting time	0 to 999.8 s	0 s
501 ^{*18}	Communication error occurrence count display	0	0
502	Stop mode selection at communication error	0 to 4	0
503	Maintenance timer 1	0 (1 to 9998)	0
504	Maintenance timer 1 alarm output set time	0 to 9998, 9999	9999
505	Speed setting reference	1 to 590 Hz	60/50 Hz ^{*10}
516	S-pattern time at a start of acceleration	0.1 to 2.5 s	0.1 s
517	S-pattern time at a completion of acceleration	0.1 to 2.5 s	0.1 s
518	S-pattern time at a start of deceleration	0.1 to 2.5 s	0.1 s
519	S-pattern time at a completion of deceleration	0.1 to 2.5 s	0.1 s
522	Output stop frequency	0 to 590 Hz, 9999	9999
539	Modbus-RTU communication check time interval	0 to 999.8 s, 9999	9999
541 ^{*18, *19}	Frequency command sign selection	0, 1	0
544 ^{*19}	CC-Link extended setting	0, 1, 12, 14, 18, 24, 28, 100, 112, 114, 118, 128	0
547	USB communication station number	0 to 31	0
548	USB communication check time interval	0 to 999.8 s, 9999	9999
549	Protocol selection	0, 1	0
550	NET mode operation command source selection	0, 1, 5 ^{*19} , 9999	9999
551	PU mode operation command source selection	1 to 3, 5 ^{*19} , 9999	9999
552	Frequency jump range	0 to 30 Hz, 9999	9999
553	PID deviation limit	0 to 100%, 9999	9999
554	PID signal operation selection	0 to 3, 10 to 13	0

Parameter	Name	Setting range	Initial value
555	Current average time	0.1 to 1.0 s	1 s
556	Data output mask time	0 to 20 s	0 s
557	Current average value monitor signal output reference current	0 to 500 A ^{*2} 0 to 3600 A ^{*3}	Inverter rated current
560	Second frequency search gain	0 to 32767, 9999	9999
561	PTC thermistor protection level	0.5 to 30 kΩ, 9999	9999
563	Energization time carrying-over times	(0 to 65535)	0
564	Operating time carrying-over times	(0 to 65535)	0
565	Second motor excitation current break point	0 to 400 Hz, 9999	9999
566	Second motor excitation current low-speed scaling factor	0 to 300 %	9999
569	Second motor speed control gain	0 to 200%, 9999	9999
570	Multiple rating setting	0 to 3/ 0 to 3/ 1, 2 ^{*15}	2
571	Holding time at a start	0 to 10 s, 9999	9999
573	4mA input check selection	1 to 4, 9999	9999
574	Second motor online auto tuning	0 to 2	0
575	Output interruption detection time	0 to 3600 s, 9999	1 s
576	Output interruption detection level	0 to 590 Hz	0 Hz
577	Output interruption release level	900 to 1100%	1000%
592	Traverse function selection	0 to 2	0
593	Maximum amplitude amount	0 to 25%	10%
594	Amplitude compensation amount during deceleration	0 to 50%	10%
595	Amplitude compensation amount during acceleration	0 to 50%	10%
596	Amplitude acceleration time	0.1 to 3600 s	5 s
597	Amplitude deceleration time	0.1 to 3600 s	5 s

^{*2} For FR-A820-03160(55K) or lower and FR-A840-01800(55K) or lower

^{*3} For FR-A820-03800(75K) or higher and FR-A840-02160(75K) or higher

^{*10} Differs according to types. (FM type/CA type)

^{*15} Differs according to model types (standard model, separated converter type, IP55 compatible model).

^{*18} The setting is available only for the FR-A800-GF or when a compatible plug-in option is installed.

^{*19} The setting is available for the FR-A800-E or when a compatible plug-in option is installed.

Parameter	Name	Setting range	Initial value	Parameter	Name	Setting range	Initial value
598	Undervoltage level	175 to 215 V, 9999 ^{*17}	9999	644	Second brake opening current detection time	0 to 2 s	0.3 s
		350 to 430 V, 9999 ^{*16}					
599	X10 terminal input selection	0, 1	0/1/0 ^{*15}	645	Second brake operation time at start	0 to 5 s	0.3 s
600	First free thermal reduction frequency 1	0 to 590 Hz, 9999	9999	646	Second brake operation frequency	0 to 30 Hz	6 Hz
601	First free thermal reduction ratio 1	1 to 100%	100%	647	Second brake operation time at stop	0 to 5 s	0.3 s
602	First free thermal reduction frequency 2	0 to 590 Hz, 9999	9999	648	Second deceleration detection function selection	0, 1	0
603	First free thermal reduction ratio 2	1 to 100%	100%	650	Second brake opening current selection	0, 1	0
604	First free thermal reduction frequency 3	0 to 590 Hz, 9999	9999	651	Second brake operation frequency selection	0, 1	0
606	Power failure stop external signal input selection	0, 1	1	653	Speed smoothing control	0 to 200%	0%
607	Motor permissible load level	110 to 250%	150%	654	Speed smoothing cutoff frequency	0 to 120 Hz	20 Hz
608	Second motor permissible load level	110 to 250%, 9999	9999	655	Analog remote output selection	0, 1, 10, 11	0
609	PID set point/ deviation input selection	1 to 5	2	656	Analog remote output 1	800 to 1200%	1000%
610	PID measured value input selection	1 to 5	3	657	Analog remote output 2	800 to 1200%	1000%
611	Acceleration time at a restart	0 to 3600 s, 9999	9999	658	Analog remote output 3	800 to 1200%	1000%
617	Reverse rotation excitation current low-speed scaling factor	0 to 300 %, 9999	9999	659	Analog remote output 4	800 to 1200%	1000%
635 ^{*12}	Cumulative pulse clear signal selection	0 to 3	0	660	Increased magnetic excitation deceleration operation selection	0, 1	0
636 ^{*12}	Cumulative pulse division scaling factor	1 to 16384	1	661	Magnetic excitation increase rate	0 to 40%, 9999	9999
637 ^{*12}	Control terminal option-Cumulative pulse division scaling factor	1 to 16384	1	662	Increased magnetic excitation current level	0 to 300%	100%
638 ^{*12}	Cumulative pulse storage	0 to 3	0	663	Control circuit temperature signal output level	0 to 100°C	0°C
639	Brake opening current selection	0, 1	0	665	Regeneration avoidance frequency gain	0 to 200%	100%
640	Brake operation frequency selection	0, 1	0	668	Power failure stop frequency gain	0 to 200%	100%
641	Second brake sequence operation selection	0, 7, 8, 9999	0	673	SF-PR slip amount adjustment operation selection	2, 4, 6, 9999	9999
642	Second brake opening frequency	0 to 30 Hz	3 Hz	674	SF-PR slip amount adjustment gain	0 to 500 %	100 %
643	Second brake opening current	0 to 400%	130%				

^{*12} The setting is available only when a vector control compatible option is mounted.

^{*15} Differs according to model types (standard model, separated converter type, IP55 compatible model).

^{*16} The setting is available only with the 400 V class.

^{*17} The setting is available only with the 200 V class.



Parameter	Name	Setting range	Initial value
679	Second droop gain	0 to 100 %, 9999	9999
680	Second droop filter time constant	0 to 1 s, 9999	9999
681	Second droop function activation selection	0 to 2, 10, 11, 9999	9999
682	Second droop break point gain	0,1 to 100 %, 9999	9999
683	Second droop break point torque	0,1 to 100 %, 9999	9999
684	Tuning data unit switchover	0, 1	0
686	Maintenance timer 2	0 (1 to 9998)	0
687	Maintenance timer 2 warning output set time	0 to 9998, 9999	9999
688	Maintenance timer 3	0 (1 to 9998)	0
689	Maintenance timer 3 warning output set time	0 to 9998, 9999	9999
690	Deceleration check time	0 to 3600 s, 9999	1 s
692	Second free thermal reduction frequency 1	0 to 590 Hz, 9999	9999
693	Second free thermal reduction ratio 1	1 to 100%	100%
694	Second free thermal reduction frequency 2	0 to 590 Hz, 9999	9999
695	Second free thermal reduction ratio 2	1 to 100%	100%
696	Second free thermal reduction frequency 3	0 to 590 Hz, 9999	9999
699	Input terminal filter	5 to 50 ms, 9999	9999
702	Maximum motor frequency	0 to 400 Hz, 9999	9999
706	Induced voltage constant (phi f)	0 to 5000 mV/ (rad/s), 9999	9999
707	Motor inertia (integer)	10 to 999, 9999	9999
711	Motor Ld decay ratio	0 to 100%, 9999	9999
712	Motor Lq decay ratio	0 to 100%, 9999	9999
717	Starting resistance tuning compensation	0 to 200%, 9999	9999
721	Starting magnetic pole position detection pulse width	0 to 6000 μs, 10000 to 16000 μs, 9999	9999
724	Motor inertia (exponent)	0 to 7, 9999	9999
725	Motor protection current level	100 to 500%, 9999	9999
738	Second motor induced voltage constant (phi f)	0 to 5000 mV/ (rad/s), 9999	9999

Parameter	Name	Setting range	Initial value
739	Second motor Ld decay ratio	0 to 100%, 9999	9999
740	Second motor Lq decay ratio	0 to 100%, 9999	9999
741	Second starting resistance tuning compensation	0 to 200%, 9999	9999
742	Second motor magnetic pole detection pulse width	0 to 6000 μs, 10000 to 16000 μs, 9999	9999
743	Second motor maximum frequency	0 to 400 Hz, 9999	9999
744	Second motor inertia (integer)	10 to 999, 9999	9999
745	Second motor inertia (exponent)	0 to 7, 9999	9999
746	Second motor protection current level	100 to 500%, 9999	9999
747	Second motor low-speed range torque characteristic selection	0, 9999	9999
753	Second PID action selection	0, 10, 11, 20, 21, 50, 51, 60, 61, 70, 71, 80, 81, 90, 91, 100, 101, 1000, 1001, 1010, 1011, 2000, 2001, 2010, 2011	0
754	Second PID control automatic switchover frequency	0 to 590 Hz, 9999	9999
755	Second PID action set point	0 to 100%, 9999	9999
756	Second PID proportional band	0.1 to 1000%, 9999	100 %
757	Second PID integral time	0.1 to 3600 s, 9999	1 s
758	Second PID differential time	0.01 to 10.00 s, 9999	9999
759	PID unit selection	0 to 43, 9999	9999
760	Pre-charge fault selection	0, 1	0
761	Pre-charge ending level	0 to 100%, 9999	9999
762	Pre-charge ending time	0 to 3600 s, 9999	9999
763	Pre-charge upper detection level	0 to 100%, 9999	9999
764	Pre-charge time limit	0 to 3600 s, 9999	9999
765	Second pre-charge fault selection	0, 1	0 %

Parameter	Name	Setting range	Initial value
766	Second pre-charge ending level	0 to 100%, 9999	9999
767	Second pre-charge ending time	0 to 3600 s, 9999	9999
768	Second pre-charge upper detection level	0 to 100%, 9999	9999
769	Second pre-charge time limit	0 to 3600 s, 9999	9999
774	Operation panel monitor selection 1	1 to 3, 5 to 14, 17 to 20, 22 to 36, 38, 40 to 46, 50 to 57, 61, 62, 64, 67, 71 to 74, 87 to 98, 100, 9999	9999
775	Operation panel monitor selection 2		9999
776	Operation panel monitor selection 3		9999
777	4mA input fault operation frequency	0 to 590 Hz, 9999	9999
778	4mA input check filter	0 to 10 s	0
779	Operation frequency during communication error	0 to 590 Hz, 9999	9999
788	Low speed range torque characteristic selection	0, 9999	9999
791	Acceleration time in low-speed range	0 to 3600 s, 9999	9999
792	Deceleration time in low-speed range	0 to 3600 s, 9999	9999
799	Pulse increment setting for output power	0.1, 1, 10, 100, 1000 kWh	1 kWh
800	Control method selection	0 to 6, 9 to 14, 20, 100 to 106, 109 to 114	20
802	Pre-excitation selection	0, 1	0
803	Constant output range torque characteristic selection	0, 1, 10, 11	0
804	Torque command source selection	0, 1, 2 ^{*19} , 3 to 6	0
805	Torque command value (RAM)	600 to 1400%	1000%
806	Torque command value (RAM, EEPROM)	600 to 1400%	1000%
807	Speed limit selection	0 to 2	0
808	Forward rotation speed limit/speed limit	0 to 400 Hz	60/50 Hz ^{*10}
809	Reverse rotation speed limit/reverse-side speed limit	0 to 400 Hz, 9999	9999
810	Torque limit input method selection	0 to 2	0
811	Set resolution switchover	0, 1, 10, 11	0
812	Torque limit level (regeneration)	0 to 400%, 9999	9999
813	Torque limit level (3rd quadrant)	0 to 400%, 9999	9999

Parameter	Name	Setting range	Initial value
814	Torque limit level (4th quadrant)	0 to 400%, 9999	9999
815	Torque limit level 2	0 to 400%, 9999	9999
816	Torque limit level during acceleration	0 to 400%, 9999	9999
817	Torque limit level during deceleration	0 to 400%, 9999	9999
818	Easy gain tuning response level setting	1 to 15	2
819	Easy gain tuning selection	0 to 2	0
820	Speed control P gain 1	0 to 1000%	60%
821	Speed control integral time 1	0 to 20 s	0.333 s
822	Speed setting filter 1	0 to 5 s, 9999	9999
823 ^{*12}	Speed detection filter 1	0 to 0.1 s	0.001 s
824	Torque control P gain 1 (current loop proportional gain)	0 to 500%	100%
825	Torque control integral time 1 (current loop integral time)	0 to 500 ms	5 ms
826	Torque setting filter 1	0 to 5 s, 9999	9999
827	Torque detection filter 1	0 to 0.1 s	0 s
828	Model speed control gain	0 to 1000%	60%
830	Speed control P gain 2	0 to 1000%, 9999	9999
831	Speed control integral time 2	0 to 20 s, 9999	9999
832	Speed setting filter 2	0 to 5 s, 9999	9999
833 ^{*12}	Speed detection filter 2	0 to 0.1 s, 9999	9999
834	Torque control P gain 2	0 to 500%, 9999	9999
835	Torque control integral time 2	0 to 500 ms, 9999	9999
836	Torque setting filter 2	0 to 5 s, 9999	9999
837	Torque detection filter 2	0 to 0.1 s, 9999	9999
840	Torque bias selection	0 to 3, 24, 25, 9999	9999
841	Torque bias 1	600 to 1400%, 9999	9999
842	Torque bias 2	600 to 1400%, 9999	9999
843	Torque bias 3	600 to 1400%, 9999	9999

^{*10} Differs according to types. (FM type/CA type)

^{*12} The setting is available only when a vector control compatible option is mounted.

^{*19} The setting is available for the FR-A800-E or when a compatible plug-in option is installed.



Parameter	Name	Setting range	Initial value
844	Torque bias filter	0 to 5 s, 9999	9999
845	Torque bias operation time	0 to 5 s, 9999	9999
846	Torque bias balance compensation	0 to 10 V, 9999	9999
847	Fall-time torque bias terminal 1 bias	0 to 400%, 9999	9999
848	Fall-time torque bias terminal 1 gain	0 to 400%, 9999	9999
849	Analog input offset adjustment	0 to 200%	100%
850	Brake operation selection	0 to 2	0
851 ^{*8}	Control terminal option-Number of encoder pulses	0 to 4096	2048
852 ^{*8}	Control terminal option-Encoder rotation direction	0, 1, 100, 101	1
853 ^{*12}	Speed deviation time	0 to 100 s	1 s
854	Excitation ratio	0 to 100%	100%
855 ^{*8}	Control terminal option-Signal loss detection enable/disable selection	0, 1	0
858	Terminal 4 function assignment	0, 1, 4, 9999	0
859	Torque current/Rated PM motor current	0 to 500 A, 9999 ^{*2} 0 to 3600 A, 9999 ^{*3}	9999
860	Second motor torque current/Rated PM motor current	0 to 500 A, 9999 ^{*2} 0 to 3600 A, 9999 ^{*3}	9999
862 ^{*12}	Encoder option selection	0, 1	0
863 ^{*8}	Control terminal option-Encoder pulse division ratio	1 to 32767	1
864	Torque detection	0 to 400%	150%
865	Low speed detection	0 to 590 Hz	1.5 Hz
866	Torque monitoring reference	0 to 400%	150%
867	AM output filter	0 to 5 s	0.01 s
868	Terminal 1 function assignment	0 to 6, 9999	0
869 ^{*11}	Current output filter	0 to 5 s	0.02 s
870	Speed detection hysteresis	0 to 5 Hz	0 Hz
872 ^{*14}	Input phase loss protection selection	0, 1	0
873 ^{*8}	Speed limit	0 to 400 Hz	20 Hz

Parameter	Name	Setting range	Initial value
874	OLT level setting	0 to 400%	150%
875	Fault definition	0, 1	0
876 ^{*8}	Thermal protector input	0, 1	1
877	Speed feed forward control/model adaptive speed control selection	0 to 2	0
878	Speed feed forward filter	0 to 1 s	0 s
879	Speed feed forward torque limit	0 to 400%	150%
880	Load inertia ratio	0 to 200 times	7 times
881	Speed feed forward gain	0 to 1000%	0%
882	Regeneration avoidance operation selection	0 to 2	0
883	Regeneration avoidance operation level	300 to 800 V	380 V DC/ 760 V DC ^{*7}
884	Regeneration avoidance at deceleration detection sensitivity	0 to 5	0
885	Regeneration avoidance compensation frequency limit value	0 to 590 Hz, 9999	6 Hz
886	Regeneration avoidance voltage gain	0 to 200%	100%
888	Free parameter 1	0 to 9999	9999
889	Free parameter 2	0 to 9999	9999
891	Cumulative power monitor digit shifted times	0 to 4, 9999	9999
892	Load factor	30 to 150%	100%
893	Energy saving monitor reference (motor capacity)	0.1 to 55 kW ^{*2} 0 to 3600 kW ^{*3}	Inverter rated capacity
894	Control selection during commercial power-supply operation	0 to 3	0
895	Power saving rate reference value	0, 1, 9999	9999
896	Power unit cost	0 to 500, 9999	9999
897	Power saving monitor average time	0, 1 to 1000 h, 9999	9999
898	Power saving cumulative monitor clear	0, 1, 10, 9999	9999
899	Operation time rate (estimated value)	0 to 100%, 9999	9999

^{*2} For FR-A820-03160(55K) or lower and FR-A840-01800(55K) or lower

^{*3} For FR-A820-03800(75K) or higher and FR-A840-02160(75K) or higher

^{*7} Differs according to the voltage class. (200 V class/400 V class)

^{*8} The setting is available only when the FR-A8AP, FR-A8APR or FR-A8TP is mounted.

^{*11} The setting is available only with the CA type.

^{*12} The setting is available only when a vector control compatible option is mounted.

^{*14} Setting available for standard models and IP55 compatible models.

Parameter	Name	Setting range	Initial value
C0 (900) * ⁹	FM/CA terminal calibration * ¹⁰	—	—
C1 (901) * ⁹	AM terminal calibration	—	—
C2 (902) * ⁹	Terminal 2 frequency setting bias frequency	0 to 590 Hz	0 Hz
C3 (902) * ⁹	Terminal 2 frequency setting bias	0 to 300%	0%
125 (903) * ⁹	Terminal 2 frequency setting gain frequency	0 to 590 Hz	60/50 Hz * ¹⁰
C4 (903) * ⁹	Terminal 2 frequency setting gain	0 to 300%	100%
C5 (904) * ⁹	Terminal 4 frequency setting bias frequency	0 to 590 Hz	0 Hz
C6 (904) * ⁹	Terminal 4 frequency setting bias	0 to 300%	20%
126 (905) * ⁹	Terminal 4 frequency setting gain frequency	0 to 590 Hz	60/50 Hz * ¹⁰
C7 (905) * ⁹	Terminal 4 frequency setting gain	0 to 300%	100%
C12 (917) * ⁹	Terminal 1 bias frequency (speed)	0 to 590 Hz	0 Hz
C13 (917) * ⁹	Terminal 1 bias (speed)	0 to 300%	0%
C14 (918) * ⁹	Terminal 1 gain frequency (speed)	0 to 590 Hz	60/50 Hz * ¹⁰
C15 (918) * ⁹	Terminal 1 gain (speed)	0 to 300%	100%
C16 (919) * ⁹	Terminal 1 bias command (torque)	0 to 400%	0%
C17 (919) * ⁹	Terminal 1 bias (torque)	0 to 300%	0%
C18 (920) * ⁹	Terminal 1 gain command (torque)	0 to 400%	150%

Parameter	Name	Setting range	Initial value
C19 (920) * ⁹	Terminal 1 gain (torque)	0 to 300%	100%
C8 (930) * ^{9,11}	Current output bias signal	0 to 100%	0%
C9 (930) * ^{9,11}	Current output bias current	0 to 100%	0%
C10 (931) * ^{9,11}	Current output gain signal	0 to 100%	100%
C11 (931) * ^{9,11}	Current output gain current	0 to 100%	100%
C38 (932) * ⁹	Terminal 4 bias command (torque)	0 to 400%	0%
C39 (932) * ⁹	Terminal 4 bias (torque)	0 to 300%	20%
C40 (933) * ⁹	Terminal 4 gain command (torque)	0 to 400%	150%
C41 (933) * ⁹	Terminal 4 gain (torque)	0 to 300%	100%
C42 (934) * ⁹	PID display bias coefficient	0 to 500.00, 9999	9999
C43 (934) * ⁹	PID display bias analog value	0 to 300.0%	20%
C44 (935) * ⁹	PID display gain coefficient	0 to 500.00, 9999	9999
C45 (935) * ⁹	PID display gain analog value	0 to 300.0%	100%
977	Input voltage mode selection	0, 1	0
989	Parameter copy alarm release	10 * ² 100 * ³	10 * ² 100 * ³
990	PU buzzer control	0, 1	1
991	PU contrast adjustment	0 to 63	58
992	Operation panel setting dial push monitor selection	0 to 3, 5 to 14, 17 to 20, 22 to 36, 38, 40 to 46, 50 to 57, 61, 62, 64, 67, 71 to 74, 87 to 98, 100	0
994	Droop break point gain	0.1 to 100%, 9999	9999

*² For FR-A820-03160(55K) or lower and FR-A840-01800(55K) or lower

*³ For FR-A820-03800(75K) or higher and FR-A840-02160(75K) or higher

*⁹ The parameter number in parentheses is the one for use with the LCD operation panel and the parameter unit.

*¹⁰ Differs according to types. (FM type/CA type)

*¹¹ The setting is available only with the CA type.



Parameter	Name	Setting range	Initial value
995	Droop break point torque	0.1 to 100%	100%
997	Fault initiation	0 to 255, 9999	9999
998	PM parameter initialization <i>Simple</i>	0, 3003, 3103, 8009, 8109, 9009, 9109	0
999	Automatic parameter setting <i>Simple</i>	1, 2, 10 to 13, 20, 21, 9999	9999
1002	Lq tuning target current adjustment coefficient	50 to 150%, 9999	9999
1003	Notch filter frequency	0, 8 to 1250 Hz	0
1004	Notch filter depth	0 to 3	0
1005	Notch filter width	0 to 3	0
1006	Clock (year)	2000 to 2099	2000
1007	Clock (month, day)	101 to 131, 201 to 229, 301 to 331, 401 to 430, 501 to 531, 601 to 630, 701 to 731, 801 to 831, 901 to 930, 1001 to 1031, 1101 to 1130, 1201 to 1231	101
1008	Clock (hour, minute)	0 to 59, 100 to 159, 200 to 259, 300 to 359, 400 to 459, 500 to 559, 600 to 659, 700 to 759, 800 to 859, 900 to 959, 1000 to 1059, 1100 to 1159, 1200 to 1259, 1300 to 1359, 1400 to 1459, 1500 to 1559, 1600 to 1659, 1700 to 1759, 1800 to 1859, 1900 to 1959, 2000 to 2059, 2100 to 2159, 2200 to 2259, 2300 to 2359	0
1015	Integral stop selection at limited frequency	0, 1, 10, 11	0
1016	PTC thermistor protection detection time	0 to 60 s	0 s
1018	Monitor with sign selection	0, 9999	9999
1020	Trace operation selection	0 to 4	0
1021	Trace mode selection	0 to 2	0
1022	Sampling cycle	0 to 9	2
1023	Number of analog channels	1 to 8	4
1024	Sampling auto start	0, 1	0

Parameter	Name	Setting range	Initial value
1025	Trigger mode selection	0 to 4	0
1026	Number of sampling before trigger	0 to 100%	90%
1027	Analog source selection (1ch)	1 to 3, 5 to 14, 17 to 20, 22 to 24, 32 to 36, 40 to 42, 46, 52 to 54, 61, 62, 64, 67, 71 to 74, 87 to 98, 201 to 213, 222 to 227, 230 to 238, 240 to 247, 251 to 254	201
1028	Analog source selection (2ch)		202
1029	Analog source selection (3ch)		203
1030	Analog source selection (4ch)		204
1031	Analog source selection (5ch)		205
1032	Analog source selection (6ch)		206
1033	Analog source selection (7ch)		207
1034	Analog source selection (8ch)		208
1035	Analog trigger channel	1 to 8	1
1036	Analog trigger operation selection	0, 1	0
1037	Analog trigger level	600 to 1400	1000
1038	Digital source selection (1ch)	1 to 255	1
1039	Digital source selection (2ch)		2
1040	Digital source selection (3ch)		3
1041	Digital source selection (4ch)		4
1042	Digital source selection (5ch)		5
1043	Digital source selection (6ch)		6
1044	Digital source selection (7ch)		7
1045	Digital source selection (8ch)		8
1046	Digital trigger channel	1 to 8	1
1047	Digital trigger operation selection	0, 1	0
1048	Display-off waiting time	0 to 60 min	0 min
1049	USB host reset	0, 1	0

Parameter	Name	Setting range	Initial value
1072	DC brake judgment time for anti-sway control operation	0 to 10 s	3 s
1073	Anti-sway control operation selection	0, 1	0
1074	Anti-sway control frequency	0.05 to 3 Hz, 9999	1 Hz
1075	Anti-sway control depth	0 to 3	0
1076	Anti-sway control width	0 to 3	0
1077	Rope length	0.1 to 50 m	1 m
1078	Trolley weight	1 to 50000 kg	1 kg
1079	Load weight	1 to 50000 kg	1 kg
1103	Deceleration time at emergency stop	0 to 3600 s	5 s
1106	Torque monitor filter	0 to 5 s, 9999	9999
1107	Running speed monitor filter	0 to 5 s, 9999	9999
1108	Excitation current monitor filter	0 to 5 s, 9999	9999
1113	Speed limit method selection	0 to 2, 10, 9999	9999
1114	Torque command reverse selection	0, 1	1
1115	Speed control integral term clear time	0 to 9998 ms	0 s
1116	Constant output range speed control P gain compensation	0 to 100%	0%
1117	Speed control P gain 1 (per-unit system)	0 to 300, 9999	9999
1118	Speed control P gain 2 (per-unit system)	0 to 300, 9999	9999
1119	Model speed control gain (per-unit system)	0 to 300, 9999	9999
1121	Per-unit speed control reference frequency	0 to 400 Hz	120 Hz * ²
			60 Hz * ³
1124 * ¹⁹	Station number in inverter-to-inverter link	0 to 5, 9999	9999
1125 * ¹⁹	Number of inverters in inverter-to-inverter link system	2 to 6	2
1134	PID upper limit manipulated value	0 to 100%	100%
1135	PID lower limit manipulated value	0 to 100%	100%
1136	Second PID display bias coefficient	0 to 500, 9999	9999
1137	Second PID display bias analog value	0 to 300%	20%

Parameter	Name	Setting range	Initial value
1138	Second PID display gain coefficient	0 to 500, 9999	9999
1139	Second PID display gain analog value	0 to 300%	100%
1140	Second PID set point/deviation input selection	1 to 5	2
1141	Second PID measured value input selection	1 to 5	3
1142	Second PID unit selection	0 to 43, 9999	9999
1143	Second PID upper limit	0 to 100%, 9999	9999
1144	Second PID lower limit	0 to 100%, 9999	9999
1145	Second PID deviation limit	0.0 to 100.0%, 9999	9999
1146	Second PID signal operation selection	0 to 3, 10 to 13	0
1147	Second output interruption detection time	0 to 3600 s, 9999	1 s
1148	Second output interruption detection level	0 to 590 Hz	0 Hz
1149	Second output interruption cancel level	900 to 1100%	1000%
1150 to 1199	PLC function user parameters 1 to 50	0 to 65535	0
1220	Target position/speed selection	0 to 2	0
1221	Start command edge detection selection	0, 1	0
1222	First positioning acceleration time	0.01 to 360 s	5 s
1223	First positioning deceleration time	0.01 to 360 s	5 s
1224	First positioning dwell time	0 to 20000 ms	0 ms
1225	First positioning subfunction	0, 1, 2, 10, 11, 12, 100, 101, 102, 110, 111, 112	10
1226	Second positioning acceleration time	0.01 to 360 s	5 s
1227	Second positioning deceleration time	0.01 to 360 s	5 s
1228	Second positioning dwell time	0 to 20000 ms	0 ms
1229	Second positioning sub-function	0, 1, 2, 10, 11, 12, 100, 101, 102, 110, 111, 112	10
1230	Third positioning acceleration time	0.01 to 360 s	5 s
1231	Third positioning deceleration time	0.01 to 360 s	5 s

*² For FR-A820-03160(55K) or lower and FR-A840-01800(55K) or lower

*³ For FR-A820-03800(75K) or higher and FR-A840-02160(75K) or higher

*¹⁹ The setting is available for the FR-A800-E or when a compatible plug-in option is installed.



Parameter	Name	Setting range	Initial value
1232	Third positioning dwell time	0 to 20000 ms	0 ms
1233	Third positioning subfunction	0, 1, 2, 10, 11, 12, 100, 101, 102, 110, 111, 112	10
1234	Fourth positioning acceleration time	0.01 to 360 s	5 s
1235	Fourth positioning deceleration time	0.01 to 360 s	5 s
1236	Fourth positioning dwell time	0 to 20000 ms	0 ms
1237	Fourth positioning subfunction	0, 1, 2, 10, 11, 12, 100, 101, 102, 110, 111, 112	10
1238	Fifth positioning acceleration time	0.01 to 360 s	5 s
1239	Fifth positioning deceleration time	0.01 to 360 s	5 s
1240	Fifth positioning dwell time	0 to 20000 ms	0 ms
1241	Fifth positioning subfunction	0, 1, 2, 10, 11, 12, 100, 101, 102, 110, 111, 112	10
1242	Sixth positioning acceleration time	0.01 to 360 s	5 s
1243	Sixth positioning deceleration time	0.01 to 360 s	5 s
1244	Sixth positioning dwell time	0 to 20000 ms	0 ms
1245	Sixth positioning subfunction	0, 1, 2, 10, 11, 12, 100, 101, 102, 110, 111, 112	10
1246	Seventh positioning acceleration time	0.01 to 360 s	5 s
1247	Seventh positioning deceleration time	0.01 to 360 s	5 s
1248	Seventh positioning dwell time	0 to 20000 ms	0 ms
1249	Seventh positioning subfunction	0, 1, 2, 10, 11, 12, 100, 101, 102, 110, 111, 112	10
1250	Eighth positioning acceleration time	0.01 to 360 s	5 s
1251	Eighth positioning deceleration time	0.01 to 360 s	5 s
1252	Eighth positioning dwell time	0 to 20000 ms	0 ms
1253	Eighth positioning subfunction	0, 1, 2, 10, 11, 12, 100, 101, 102, 110, 111, 112	10
1254	Ninth positioning acceleration time	0.01 to 360 s	5 s
1255	Ninth positioning deceleration time	0.01 to 360 s	5 s
1256	Ninth positioning dwell time	0 to 20000 ms	0 ms
1257	Ninth positioning subfunction	0, 1, 2, 10, 11, 12, 100, 101, 102, 110, 111, 112	10
1258	Tenth positioning acceleration time	0.01 to 360 s	5 s

Parameter	Name	Setting range	Initial value
1259	Tenth positioning deceleration time	0.01 to 360 s	5 s
1260	Tenth positioning dwell time	0 to 20000 ms	0 ms
1261	Tenth positioning subfunction	0, 1, 2, 10, 11, 12, 100, 101, 102, 110, 111, 112	10
1262	Eleventh positioning acceleration time	0.01 to 360 s	5 s
1263	Eleventh positioning deceleration time	0.01 to 360 s	5 s
1264	Eleventh positioning dwell time	0 to 20000 ms	0 ms
1265	Eleventh positioning subfunction	0, 1, 2, 10, 11, 12, 100, 101, 102, 110, 111, 112	10
1266	Twelfth positioning acceleration time	0.01 to 360 s	5 s
1267	Twelfth positioning deceleration time	0.01 to 360 s	5 s
1268	Twelfth positioning dwell time	0 to 20000 ms	0 ms
1269	Twelfth positioning subfunction	0, 1, 2, 10, 11, 12, 100, 101, 102, 110, 111, 112	10
1270	Thirteenth positioning acceleration time	0.01 to 360 s	5 s
1271	Thirteenth positioning deceleration time	0.01 to 360 s	5 s
1272	Thirteenth positioning dwell time	0 to 20000 ms	0 ms
1273	Thirteenth positioning subfunction	0, 1, 2, 10, 11, 12, 100, 101, 102, 110, 111, 112	10
1274	Fourteenth positioning acceleration time	0.01 to 360 s	5 s
1275	Fourteenth positioning deceleration time	0.01 to 360 s	5 s
1276	Fourteenth positioning dwell time	0 to 20000 ms	0 ms
1277	Fourteenth positioning subfunction	0, 1, 2, 10, 11, 12, 100, 101, 102, 110, 111, 112	10
1278	Fifteenth positioning acceleration time	0.01 to 360 s	5 s
1279	Fifteenth positioning deceleration time	0.01 to 360 s	5 s
1280	Fifteenth positioning dwell time	0 to 20000 ms	0 ms
1281	Fifteenth positioning subfunction	0, 2, 10, 12, 100, 102, 110, 112	10

Parameter	Name	Setting range	Initial value
1282	Home position return method selection	0 to 6	4
1283	Home position return speed	0 to 30 Hz	2 Hz
1284	Home position return creep speed	0 to 10 Hz	0.5 Hz
1285	Home position shift amount lower 4 digits	0 to 9999	0
1286	Home position shift amount upper 4 digits	0 to 9999	0
1287	Travel distance after proximity dog ON lower 4 digits	0 to 9999	2048
1288	Travel distance after proximity dog ON upper 4 digits	0 to 9999	0
1289	Home position return stopper torque	0 to 200%	40%
1290	Home position return stopper waiting time	0 to 10 s	0.5 s
1292	Position control terminal input selection	0, 1	0
1293	Roll feeding mode selection	0, 1	0
1294	Position detection lower 4 digits	0 to 9999	0
1295	Position detection upper 4 digits	0 to 9999	0
1296	Position detection selection	0 to 2	0
1297	Position detection hysteresis width	0 to 32767	0
1298	Second position control gain	0 to 150 s ⁻¹	25 s ⁻¹
1299	Second pre-excitation selection	0, 1	0
1300 to 1343	Communication option parameters		
1350 to 1359			
1410	Starting times lower 4 digits	0 to 9999	0
1411	Starting times upper 4 digits	0 to 9999	0
1412	Motor induced voltage constant (phi f) exponent	0 to 2, 9999	9999
1413	Second motor induced voltage constant (phi f) exponent	0 to 2, 9999	9999

Parameter	Name	Setting range	Initial value
1424 ^{*19}	Ethernet communication network number	1 to 239	1
1425 ^{*19}	Ethernet communication station number	1 to 120	1
1426 ^{*19}	Link speed and duplex mode selection	0 to 4	0
1427 ^{*19}	Ethernet function selection 1	502, 5000 to 5002, 5006 to 5008, 5010 to 5013, 9999, 45237, 61450	5001
1428 ^{*19}	Ethernet function selection 2	502, 5000 to 5002, 5006 to 5008, 5010 to 5013, 9999, 45237, 61450	45237
1429 ^{*19}	Ethernet function selection 3	502, 5000 to 5002, 5006 to 5008, 5010 to 5013, 9999, 45237, 61450	9999
1431 ^{*19}	Ethernet signal loss detection function selection	0 to 3	0
1432 ^{*19}	Ethernet communication check time interval	0 to 999.8 s, 9999	9999
1434 ^{*19}	Ethernet IP address 1	0 to 255	192
1435 ^{*19}	Ethernet IP address 2	0 to 255	168
1436 ^{*19}	Ethernet IP address 3	0 to 255	50
1437 ^{*19}	Ethernet IP address 4	0 to 255	1
1438 ^{*19}	Subnet mask 1	0 to 255	255
1439 ^{*19}	Subnet mask 2	0 to 255	255
1440 ^{*19}	Subnet mask 3	0 to 255	255
1441 ^{*19}	Subnet mask 4	0 to 255	0
1442 ^{*19}	Ethernet IP filter address 1	0 to 255	0
1443 ^{*19}	Ethernet IP filter address 2	0 to 255	0
1444 ^{*19}	Ethernet IP filter address 3	0 to 255	0
1445 ^{*19}	Ethernet IP filter address 4	0 to 255	0
1446 ^{*19}	Ethernet IP filter address 2 range specification	0 to 255, 9999	9999
1447 ^{*19}	Ethernet IP filter address 3 range specification	0 to 255, 9999	9999
1448 ^{*19}	Ethernet IP filter address 4 range specification	0 to 255, 9999	9999
1449 ^{*19}	Ethernet command source selection IP address 1	0 to 255	0

^{*19} The setting is available for the FR-A800-E or when a compatible plug-in option is installed.



Parameter	Name	Setting range	Initial value
1450 ^{*19}	Ethernet command source selection IP address 2	0 to 255	0
1451 ^{*19}	Ethernet command source selection IP address 3	0 to 255	0
1452 ^{*19}	Ethernet command source selection IP address 4	0 to 255	0
1453 ^{*19}	Ethernet command source selection IP address 3 range specification	0 to 255, 9999	0
1454 ^{*19}	Ethernet command source selection IP address 4 range specification	0 to 255, 9999	0
1455 ^{*19}	Keepalive time	1 to 7200 s	3600 s
1480	Load characteristics measurement mode	0, 1, (2 to 5, 81 to 85)	0
1481	Load characteristics load reference 1	0 to 400%, 9999	9999
1482	Load characteristics load reference 2	0 to 400%, 9999	9999
1483	Load characteristics load reference 3	0 to 400%, 9999	9999
1484	Load characteristics load reference 4	0 to 400%, 9999	9999
1485	Load characteristics load reference 5	0 to 400%, 9999	9999
1486	Load characteristics maximum frequency	0 to 590 Hz	60/50 Hz ^{*10}
1487	Load characteristics minimum frequency	0 to 590 Hz	6 Hz

Parameter	Name	Setting range	Initial value
1488	Upper limit warning detection width	0 to 400%, 9999	20%
1489	Lower limit warning detection width	0 to 400%, 9999	20%
1490	Upper limit fault detection width	0 to 400%, 9999	9999
1491	Lower limit fault detection width	0 to 400%, 9999	9999
1492	Load status detection signal delay time / load reference measurement waiting time	0 to 60 s	1 s
Pr.CLR	Parameter clear	(0,) 1	0
ALL.CL	All parameter clear	(0,) 1	0
Err.CL	Fault history clear	(0,) 1	0
Pr.CPY	Parameter copy	(0,) 1 to 3	0
Pr.CHG	Initial value change list	—	—
IPM	IPM initialization	0, 3003	0
AUTO	Automatic parameter setting	—	—
Pr.MD	Group parameter setting	(0,) 1, 2	0

^{*10} Differs according to types. (FM type/CA type)

^{*19} The setting is available for the FR-A800-E or when a compatible plug-in option is installed.

6 TROUBLESHOOTING

When a fault occurs in the inverter, the protective function activates, and the PU display automatically changes to one of the fault or alarm indications listed on *page 60*.

If the fault does not correspond to any of the following errors or if you have any other problem, please contact your sales representative.

- Retention of alarm output signal.....When the magnetic contactor (MC) provided on the input side of the inverter is opened at the activation of the protective function, the inverter's control power will be lost and the alarm output will not be held.
- Alarm display.....When the protective function is activated, the operation panel display automatically switches to the fault or alarm indication.
- Resetting methodWhen a protective function of the inverter is activated, the inverter output is kept stopped. Unless reset, the inverter cannot restart. (Refer to *page 60*.)
- When the protective functions were activated, take an appropriate corrective action, then reset the inverter, and resume the operation. Not doing so may lead to an inverter fault and damage.

Inverter fault or alarm indications are roughly divided as below:

- Error message
A message regarding operational fault and setting fault by the operation panel (FR-DU08, FR-DU08-01, FR-LU08) and parameter unit (FR-PU07) is displayed. The inverter does not shut off output.
- Warning
The inverter does not shut off output even when a warning is displayed. However, failure to take appropriate measures will lead to a fault.
- Alarm
The inverter does not shut off output. You can also output an alarm signal (LF) by making parameter setting.
- Fault
When the protective function is activated, the inverter output is shut off and a fault signal (ALM) is output.
- Other message
A message regarding the operational status of the inverter is displayed. The inverter does not trip.

NOTES

- For the details of fault displays and other malfunctions, also refer to the FR-A800 Instruction Manual.
- Past eight faults can be displayed using the setting dial. (Refer to *page 39*.)
- The model with the symbol GF is not available in Europe. You can get the same functionality of this model by installing the option FR-A8NCE (Art. no. 273102).
- Upon delivery the FR-A800-E inverter models are not equipped with the RS-485 terminal block.



6.1 Reset method of protective function

The inverter can be reset by performing any of the following operations. Note that the internal thermal integrated value of the electronic thermal relay function and the number of retries are cleared (erased) by resetting the inverter. Inverter recovers about 1s after reset is cancelled.

Three different methods can be used to reset an inverter.

- Using the operation panel, press the STOP/RESET key to reset the inverter. (This may only be performed when a fault occurs.)

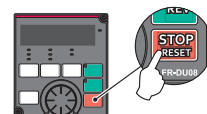

- Switch OFF the power once, then switch it ON again after the indicator of the operation panel turns OFF.

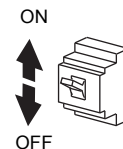

- Turn ON the Reset signal (RES) for more than 0.1 s. (If the RES signal is kept ON, "Err." appears (flickers) to indicate that the inverter is in a reset status.)

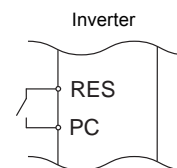

CAUTION

OFF status of the start signal must be confirmed before resetting the inverter fault. Resetting inverter fault with the start signal ON restarts the motor suddenly. This may cause injury.

6.2 List of alarm display

Operation panel indication		Name	Data code	
Error message	HOLD	HOLD	Operation panel lock	—
	LOCd	LOCD	Password locked	—
	Er 1 to Er 4 Er 8	Er1 to Er4 Er8	Parameter write error	—
	rE 1 to rE 4 rE 6 to rE 8	rE1 to rE4 rE6 to rE8	Copy operation error	—
	Err.	Err.	Error	—
	Warning	OL	OL	Stall prevention (overcurrent)
oL		oL	Stall prevention (overvoltage)	—
Rb		RB *1 *2	Regenerative brake pre-alarm	—
TH		TH	Electronic thermal relay function pre-alarm	—
PS		PS	PU Stop	—
MF 1 to MF 3		MT1 to MT3	Maintenance signal output	—

Operation panel indication		Name	Data code	
Warning	CP	CP *2	Parameter copy	—
	SL	SL	Speed limit indication	—
	CF	CF	Continuous operation during communication fault	—
	SA	SA	Safety stop	—
	UF	UF	USB host error	—
	HP 1	HP1	Home position return setting error	—
	HP 2	HP2	Home position return uncompleted	—
	HP 3	HP3	Home position return parameter setting error	—
	LdF	LDF	Load fault warning	—
Alarm	EHR	EHR *4	Ethernet communication fault	—
	FN	FN	Fan alarm	—
Fault	FN2	FN2 *3	Internal fan alarm	—
	E. OC 1	E.OC1	Overcurrent trip during acceleration	16 (H10)
	E. OC 2	E.OC2	Overcurrent trip during constant speed	17 (H11)
	E. OC 3	E.OC3	Overcurrent trip during deceleration or stop	18 (H12)

For footnotes *1 to *4 refer to next page.

Operation panel indication		Name	Data code
E. OV1	E.OV1	Regenerative overvoltage trip during acceleration	32 (H20)
E. OV2	E.OV2	Regenerative overvoltage trip during constant speed	33 (H21)
E. OV3	E.OV3	Regenerative overvoltage trip during deceleration or stop	34 (H22)
E. THT	E.THT	Inverter overload trip (electronic thermal relay function)	48 (H30)
E. THM	E.THM	Motor overload trip (electronic thermal relay function)	49 (H31)
E. FIN	E.FIN	Heatsink overheat	64 (H40)
E. IPF	E.IPF *1	Instantaneous power failure	80 (H50)
E. UVT	E.UVT *1	Undervoltage	81 (H51)
E. ILF	E.ILF *1	Input phase loss	82 (H52)
E. OLT	E.OLT	Stall prevention stop	96 (H60)
E. SOT	E.SOT	Loss of synchronism detection	97 (H61)
E. LUP	E.LUP	Upper limit fault detection	98 (H62)
E. LDN	E.LDN	Lower limit fault detection	99 (H63)
E. BE	E.BE *1	Brake transistor alarm detection	112 (H70)
E. GF	E.GF	Output side earth fault overcurrent	128 (H80)
E. LF	E.LF	Output phase loss	129 (H81)
E. OHT	E.OHT	External thermal relay operation	144 (H90)
E. PTC	E.PTC	PTC thermistor operation	145 (H91)
E. OPT	E.OPT	Option fault	160 (HA0)
E. OP1	E.OP1	Communication option fault	161 (HA1)
E. OP2	E.OP2		162 (HA2)
E. OP3	E.OP3		163 (HA3)
E. to 16 E. 20	E.16 to E.20	User definition error by the PLC function	164–168 (HA4–HA8)
E. PE	E.PE	Parameter storage device fault	176 (HB0)
E. PUE	E.PUE	PU disconnection	177 (HB1)
E. RET	E.RET	Retry count excess	178 (HB2)
E. PE2	E.PE2	Parameter storage device fault	179 (HB3)
E. CPU	E.CPU	CPU fault	192 (HC0)
E. CTE	E.CTE	Operation panel power supply short circuit / RS-485 terminal power supply short circuit (FR-A800-E without RS-485 terminals)	193 (HC1)

Fault

Operation panel indication		Name	Data code
E. P24	E.P24	24V DC power fault	194 (HC2)
E. CDO	E.CDO	Abnormal output current detection	196 (HC4)
E. IOH	E.IOH *1	Inrush current limit circuit fault	197 (HC5)
E. SER	E.SER *5	Communication fault (inverter)	198 (HC6)
E. AIE	E.AIE	Analog input fault	199 (HC7)
E. USB	E.USB	USB communication fault	200 (HC8)
E. SAF	E.SAF	Safety circuit fault	201 (HC9)
E. PBT	E.PBT	Internal circuit fault	202 (HCA)
E. OS	E.OS	Overspeed occurrence	208 (HD0)
E. OSD	E.OSD	Speed deviation excess detection	209 (HD1)
E. ECT	E.ECT	Signal loss detection	210 (HD2)
E. OD	E.OD	Excessive position fault	211 (HD3)
E. MB1 to MB7	E.MB1 to E.MB7	Brake sequence fault	213–219 (HD5–HDB)
E. EP	E.EP	Encoder phase fault	220 (HDC)
E. MP	E.MP	Magnetic pole position unknown	222 (HDE)
E. IAH	E.IAH *3	Abnormal internal temperature	225 (HE1)
E. LCI	E.LCI	4mA input fault	228 (HE4)
E. PCH	E.PCH	Pre-charge fault	229 (HE5)
E. PID	E.PID	PID signal fault	230 (HE6)
E. EHR	E.EHR *4	Ethernet communication fault	231 (HE7)
E. 1 to 3	E. 1 to E. 3	Option fault	241–243 (HF1–HF3)
E. 5 to 7	E. 5 to E. 7	CPU fault	245–247 (HF5–HF7)
E. 11	E.11	Opposite rotation deceleration fault	251 (HFB)
E. 13	E.13	Internal circuit fault	253 (HFD)
E. - - - -	E. - - - -	Faults history	—
E. EV	EV	24 V external power supply operation	—
E. RD	RD	Backup in progress	—
E. WR	WR	Restoration in progress	—

Fault

Others

*1 Not available for FR-A842 (Separated converter type)

*2 Not available for FR-A846 (IP55 compatible models)

*3 Available for FR-A846 (IP55 compatible models) only

*4 Available for FR-A800-E only

*5 Not available for FR-A800-E

7 SPECIFICATIONS

7.1 Rating

7.1.1 FR-A820 (200 V class)

Model FR-A820-□		00046 (0.4K)	00077 (0.75K)	00105 (1.5K)	00167 (2.2K)	00250 (3.7K)	00340 (5.5K)	00490 (7.5K)	00630 (11K)	00770 (15K)	00930 (18.5K)	01250 (22K)	01540 (30K)	01870 (37K)	02330 (45K)	03160 (55K)	03800 (75K)	04750 (90K)		
Applicable motor capacity [kW] ^{*1}	SLD	0.75	1.5	2.2	3.7	5.5	7.5	11	15	18.5	22	30	37	45	55	75	110	132		
	LD	0.75	1.5	2.2	3.7	5.5	7.5	11	15	18.5	22	30	37	45	55	75	90	110		
	ND (initial setting)	0.4	0.75	1.5	2.2	3.7	5.5	7.5	11	15	18.5	22	30	37	45	55	75	90		
	HD	0.2 ^{*2}	0.4	0.75	1.5	2.2	3.7	5.5	7.5	11	15	18.5	22	30	37	45	55	75		
Rated capacity [kVA] ^{*3}	SLD	1.8	2.9	4	6.4	10	13	19	24	29	35	48	59	71	89	120	145	181		
	LD	1.6	2.7	3.7	5.8	8.8	12	17	22	27	32	43	53	65	81	110	132	165		
	ND (initial setting)	1.1	1.9	3	4.2	6.7	9.1	13	18	23	29	34	44	55	67	82	110	132		
	HD	0.6	1.1	1.9	3	4.2	6.7	9.1	13	18	23	29	34	44	55	67	82	110		
Rated current [A]	SLD	4.6	7.7	10.5	16.7	25	34	49	63	77	93	125	154	187	233	316	380	475		
	LD	4.2	7	9.6	15.2	23	31	45	58	70.5	85	114	140	170	212	288	346	432		
	ND (initial setting)	3	5	8	11	17.5	24	33	46	61	76	90	115	145	175	215	288	346		
	HD	1.5	3	5	8	11	17.5	24	33	46	61	76	90	115	145	175	215	288		
Overload current rating ^{*4}	SLD	110% of rated motor capacity for 60 s, 120% of rated motor capacity for 3 s (max. surrounding air temperature 40°C)																		
	LD	120% of rated motor capacity for 60 s, 150% of rated motor capacity for 3 s (max. surrounding air temperature 50°C)																		
	ND (initial setting)	150% of rated motor capacity for 60 s, 200% of rated motor capacity for 3 s (max. surrounding air temperature 50°C)																		
	HD	200% of rated motor capacity for 60 s, 250% of rated motor capacity for 3 s (max. surrounding air temperature 50°C)																		
Rated voltage ^{*5}		Three-phase 200 to 240 V																		
Regenerative braking	Brake transistor	Built-in												FR-BU2 (Option)						
	Maximum brake torque ^{*7}	150% torque/3%ED ^{*6}				100% torque/3%ED ^{*6}		100% torque/2%ED ^{*6}		20% torque/continuous							10% torque/continuous			
	FR-ABR (when the option is used)	150% torque/10%ED			100% torque/10%ED				100% torque/6%ED				—	—	—	—	—	—		
Rated input AC voltage/frequency		Three-phase 200 to 240 V 50 Hz/60 Hz																		
Permissible AC voltage fluctuation		170 to 264 V 50 Hz/60 Hz																		
Permissible frequency fluctuation		±5%																		
Power supply	Rated input current [A] ^{*8}	Without DC reactor	SLD	5.3	8.9	13.2	19.7	31.3	45.1	62.8	80.6	96.7	115	151	185	221	269	—	—	—
			LD	5	8.3	12.2	18.3	28.5	41.6	58.2	74.8	90.9	106	139	178	207	255	—	—	—
			ND (initial setting)	3.9	6.3	10.6	14.1	22.6	33.4	44.2	60.9	80	96.3	113	150	181	216	266	—	—
		With DC reactor	SLD	4.6	7.7	10.5	16.7	25	34	49	63	77	93	125	154	187	233	316	380	475
			LD	4.2	7	9.6	15.2	23	31	45	58	70.5	85	114	140	170	212	288	346	432
			ND (initial setting)	3	5	8	11	17.5	24	33	46	61	76	90	115	145	175	215	288	346
	Power supply capacity [kVA] ^{*9}	Without DC reactor	SLD	2	3.4	5	7.5	12	17	24	31	37	44	58	70	84	103	—	—	—
			LD	1.9	3.2	4.7	7	11	16	22	29	35	41	53	68	79	97	—	—	—
			ND (initial setting)	1.5	2.4	4	5.4	8.6	13	17	23	30	37	43	57	69	82	101	—	—
		With DC reactor	SLD	1.8	2.9	4	6.4	10	13	19	24	29	35	48	59	71	89	120	145	181
			LD	1.6	2.7	3.7	5.8	8.8	12	17	22	27	32	43	53	65	81	110	132	165
			ND (initial setting)	1.1	1.9	3	4.2	6.7	9.1	13	18	23	29	34	44	55	67	82	110	132
Protective structure ^{*10}		IP20												IP00						
Cooling system		Self-cooling				Forced air cooling														
Weight [kg]		2.0	2.2	3.3	3.3	3.3	6.7	6.7	8.3	15	15	15	22	42	42	54	74	74		

- ^{*1} The applicable motor capacity indicated is the maximum capacity applicable for use of the Mitsubishi Electric 4-pole standard motor.
- ^{*2} The 0.2 kW motor capacity is applicable under V/F control only.
- ^{*3} The rated output capacity indicated assumes that the output voltage is 220 V.
- ^{*4} The % value of the overload current rating indicated is the ratio of the overload current to the inverter's rated output current. For repeated duty, allow time for the inverter and motor to return to or below the temperatures under 100% load.
- ^{*5} The maximum output voltage does not exceed the power supply voltage. The maximum output voltage can be changed within the setting range. However, the maximum point of the voltage waveform at the inverter output side is the power supply voltage multiplied by about $\sqrt{2}$.
- ^{*6} Value by the built-in brake resistor
- ^{*7} Value for the ND rating
- ^{*8} The rated input current indicates a value at a rated output voltage. The impedance at the power supply side (including those of the input reactor and cables) affects the rated input current.
- ^{*9} The power supply capacity is the value when at the rated output current. It varies by the impedance at the power supply side (including those of the input reactor and cables).
- ^{*10} FR-DU08: IP40 (except for the PU connector section)



7.1.2 FR-A840 (400 V class)

Model FR-A840-□		00023 (0.4K)	00038 (0.75K)	00052 (1.5K)	00083 (2.2K)	00126 (3.7K)	00170 (5.5K)	00250 (7.5K)	00310 (11K)	00380 (15K)	00470 (18.5K)	00620 (22K)	00770 (30K)	00930 (37K)	01160 (45K)	01800 (55K)	02160 (75K)	02600 (90K)	03250 (110K)	03610 (132K)	04320 (160K)	04810 (185K)	05470 (220K)	06100 (250K)	06830 (280K)		
Applicable motor capacity [kW] ^{*1}	SLD	0.75	1.5	2.2	3.7	5.5	7.5	11	15	18.5	22	30	37	45	55	75	110	132	160	185	220	250	280	315	355		
	LD	0.75	1.5	2.2	3.7	5.5	7.5	11	15	18.5	22	30	37	45	55	75	90	110	132	160	185	220	250	280	315		
	ND (initial setting)	0.4	0.75	1.5	2.2	3.7	5.5	7.5	11	15	18.5	22	30	37	45	55	75	90	110	132	160	185	220	250	280		
	HD	0.2 ^{*2}	0.4	0.75	1.5	2.2	3.7	5.5	7.5	11	15	18.5	22	30	37	45	55	75	90	110	132	160	185	220	250		
Output	Rated capacity [kVA] ^{*3}	SLD	1.8	2.9	4	6.3	10	13	19	24	29	36	47	59	71	88	137	165	198	248	275	329	367	417	465	521	
		LD	1.6	2.7	3.7	5.8	8.8	12	18	22	27	33	43	53	65	81	110	137	165	198	248	275	329	367	417	465	
		ND (initial setting)	1.1	1.9	3	4.6	6.9	9.1	13	18	24	29	34	43	54	66	84	110	137	165	198	248	275	329	367	417	
		HD	0.6	1.1	1.9	3	4.6	6.9	9.1	13	18	24	29	34	43	54	66	84	110	137	165	198	248	275	329	367	
	Rated current [A]	SLD	2.3	3.8	5.2	8.3	12.6	17	25	31	38	47	62	77	93	116	180	216	260	325	361	432	481	547	610	683	
		LD	2.1	3.5	4.8	7.6	11.5	16	23	29	35	43	57	70	85	106	144	180	216	260	325	361	432	481	547	610	
		ND (initial setting)	1.5	2.5	4	6	9	12	17	23	31	38	44	57	71	86	110	144	180	216	260	325	361	432	481	547	
		HD	0.8	1.5	2.5	4	6	9	12	17	23	31	38	44	57	71	86	110	144	180	216	260	325	361	432	481	
	Overload current rating ^{*4}	SLD	110% of rated motor capacity for 60 s, 120% of rated motor capacity for 3 s (max. surrounding air temperature 40°C)																								
		LD	120% of rated motor capacity for 60 s, 150% of rated motor capacity for 3 s (max. surrounding air temperature 50°C)																								
		ND (initial setting)	150% of rated motor capacity for 60 s, 200% of rated motor capacity for 3 s (max. surrounding air temperature 50°C)																								
		HD	200% of rated motor capacity for 60 s, 250% of rated motor capacity for 3 s (max. surrounding air temperature 50°C)																								
Rated voltage ^{*5}		Three-phase 380 to 500 V																									
Regenerative braking	Brake transistor	Built-in															FR-BU2 (Option)										
	Maximum brake torque ^{*7}	100% torque/2%ED ^{*6}										20% torque/continuous					10% torque/continuous										
	FR-ABR (when the option is used)	100% torque/10%ED										100% torque/6%ED					— ^{*12}										
Rated input AC voltage/frequency		Three-phase 380 to 500 V 50 Hz/60 Hz ^{*11}																									
Permissible AC voltage fluctuation		323 to 550 V 50 Hz/60 Hz																									
Permissible frequency fluctuation		±5%																									
Power supply	Rated input current [A] ^{*8}	Without DC reactor	SLD	3.2	5.4	7.8	10.9	16.4	22.5	31.7	40.3	48.2	58.4	76.8	97.6	115	141	—	—	—	—	—	—	—	—	—	
			LD	3	4.9	7.3	10.1	15.1	22.3	31	38.2	44.9	53.9	75.1	89.7	106	130	—	—	—	—	—	—	—	—	—	—
			ND (initial setting)	2.3	3.7	6.2	8.3	12.3	17.4	22.5	31	40.3	48.2	56.5	75.1	91	108	134	—	—	—	—	—	—	—	—	—
			HD	1.4	2.3	3.7	6.2	8.3	12.3	17.4	22.5	31	40.3	48.2	56.5	75.1	91	108	—	—	—	—	—	—	—	—	—
	With DC reactor	SLD	2.3	3.8	5.2	8.3	12.6	17	25	31	38	47	62	77	93	116	180	216	260	325	361	432	481	547	610	683	
		LD	2.1	3.5	4.8	7.6	11.5	16	23	29	35	43	57	70	85	106	144	180	216	260	325	361	432	481	547	610	
		ND (initial setting)	1.5	2.5	4	6	9	12	17	23	31	38	44	57	71	86	110	144	180	216	260	325	361	432	481	547	
		HD	0.8	1.5	2.5	4	6	9	12	17	23	31	38	44	57	71	86	110	144	180	216	260	325	361	432	481	
	Power supply capacity [kVA] ^{*9}	Without DC reactor	SLD	2.5	4.1	5.9	8.3	12	17	24	31	37	44	59	74	88	107	—	—	—	—	—	—	—	—	—	—
			LD	2.3	3.7	5.5	7.7	12	17	24	29	34	41	57	68	81	99	—	—	—	—	—	—	—	—	—	—
			ND (initial setting)	1.7	2.8	4.7	6.3	9.4	13	17	24	31	37	43	57	69	83	102	—	—	—	—	—	—	—	—	—
			HD	1.1	1.7	2.8	4.7	6.3	9.4	13	17	24	31	37	43	57	69	83	—	—	—	—	—	—	—	—	—
With DC reactor		SLD	1.8	2.9	4	6.3	10	13	19	24	29	36	47	59	71	88	137	165	198	248	275	329	367	417	465	521	
		LD	1.6	2.7	3.7	5.8	8.8	12	18	22	27	33	43	53	65	81	110	137	165	198	248	275	329	367	417	465	
		ND (initial setting)	1.1	1.9	3	4.6	6.9	9.1	13	18	24	29	34	43	54	66	84	110	137	165	198	248	275	329	367	417	
		HD	0.6	1.1	1.9	3	4.6	6.9	9.1	13	18	24	29	34	43	54	66	84	110	137	165	198	248	275	329	367	
Protective structure ^{*10}		IP20												IP00													
Cooling system		Self-cooling					Forced air cooling																				
Weight [kg]		2.8	2.8	2.8	3.3	3.3	6.7	6.7	8.3	8.3	15	15	23	41	41	43	52	55	71	78	117	117	166	166	166		

^{*1} The applicable motor capacity indicated is the maximum capacity applicable for use of the Mitsubishi Electric 4-pole standard motor.
^{*2} The 0.2 kW motor capacity is applicable under V/F control only.
^{*3} The rated output capacity indicated assumes that the output voltage is 440 V.
^{*4} The % value of the overload current rating indicated is the ratio of the overload current to the inverter's rated output current. For repeated duty, allow time for the inverter and motor to return to or below the temperatures under 100% load.
^{*5} The maximum output voltage does not exceed the power supply voltage. The maximum output voltage can be changed within the setting range. However, the maximum point of the voltage waveform at the inverter output side is the power supply voltage multiplied by about $\sqrt{2}$.
^{*6} Value for the built-in brake resistor
^{*7} Value for the ND rating
^{*8} The rated input current indicates a value at a rated output voltage. The impedance at the power supply side (including those of the input reactor and cables) affects the rated input current.
^{*9} The power supply capacity is the value when at the rated output current. It varies by the impedance at the power supply side (including those of the input reactor and cables).
^{*10} FR-DU08: IP40 (except for the PU connector section)
^{*11} For the power voltage exceeding 480 V, set Pr. 977 "Input voltage mode selection". (For details, refer to the FR-A800 Instruction Manual.)
^{*12} The braking capability of the inverter built-in brake can be improved with a commercial brake resistor. For the details, please contact your sales representative.



7.1.3 FR-A842 (400 V class)

Model FR-A842-□		07700 (315K)	08660 (355K)	09620 (400K)	10940 (450K)	12120 (500K)
Applicable motor capacity [kW] *1	SLD	400	450	500	560	630
	LD	355	400	450	500	560
	ND (initial setting)	315	355	400	450	500
	HD	280	315	355	400	450
Rated capacity [kVA] *2	SLD	587	660	733	834	924
	LD	521	587	660	733	834
	ND (initial setting)	465	521	587	660	733
	HD	417	465	521	587	660
Rated current [A]	SLD	770	866	962	1094	1212
	LD	683	770	866	962	1094
	ND (initial setting)	610	683	770	866	962
	HD	547	610	683	770	866
Overload current rating *3	SLD	110% of rated motor capacity for 60 s, 120% of rated motor capacity for 3 s (max. surrounding air temperature 40°C)				
	LD	120% of rated motor capacity for 60 s, 150% of rated motor capacity for 3 s (max. surrounding air temperature 50°C)				
	ND (initial setting)	150% of rated motor capacity for 60 s, 200% of rated motor capacity for 3 s (max. surrounding air temperature 50°C)				
	HD	200% of rated motor capacity for 60 s, 250% of rated motor capacity for 3 s (max. surrounding air temperature 50°C)				
Rated voltage *4		Three-phase 380 to 500 V				
Regenerative braking torque *5 (when the converter unit FR-CC2 is used)	Maximum brake torque	10% torque/continuous				
Control power supply auxiliary input		Single-phase 380 to 500 V 50 Hz/60 Hz *7				
DC power supply voltage		430 to 780 V DC				
Permissible control power supply auxiliary input fluctuation		Frequency ±5%, voltage ±10%				
Protective structure (IEC 60529) *6		IP00				
Cooling system		Forced air cooling				
Weight [kg]		163	163	243	243	243

*1 The applicable motor capacity indicated is the maximum capacity applicable for use of the Mitsubishi Electric 4-pole standard motor.

*2 The rated output capacity indicated assumes that the output voltage is 440 V.

*3 The % value of the overload current rating indicated is the ratio of the overload current to the inverter's rated output current. For repeated duty, allow time for the inverter and motor to return to or below the temperatures under 100% load.

*4 The maximum output voltage does not exceed the power supply voltage. The maximum output voltage can be changed within the setting range. However, the maximum point of the voltage waveform at the inverter output side is the power supply voltage multiplied by about $\sqrt{2}$.

*5 Value for the ND rating

*6 FR-DU08: IP40 (except for the PU connector section)

*7 For the power voltage exceeding 480 V, set Pr. 977 "Input voltage mode selection". (For details, refer to the FR-A800 Instruction Manual.)

For ratings of the converter unit (FR-CC2) refer to the FR-CC2 Instruction Manual.

7.1.4 FR-A846 (400 V class)

Model FR-A846-□		00023 (0.4K)	00038 (0.75K)	00052 (1.5K)	00083 (2.2K)	00126 (3.7K)	00170 (5.5K)	00250 (7.5K)	00310 (11K)	00380 (15K)	00470 (18.5K)	00620 (22K)	00770 (30K)	00930 (37K)	01160 (45K)	01800 (55K)	02160 (75K)	02600 (90K)	03250 (110K)	03610 (132K)
Applicable motor capacity [kW] *1	LD	0.75	1.5	2.2	3.7	5.5	7.5	11	15	18.5	22	30	37	45	55	75	90	110	132	160
	ND (initial setting)	0.4	0.75	1.5	2.2	3.7	5.5	7.5	11	15	18.5	22	30	37	45	55	75	90	110	132
Rated capacity [kVA] *2	LD	1.6	2.7	3.7	5.8	8.8	12	18	22	27	33	43	53	65	81	110	137	165	198	248
	ND (initial setting)	1.1	1.9	3	4.6	6.9	9.1	13	18	24	29	34	43	54	66	84	110	137	165	198
Rated current [A]	LD	2.1	3.5	4.8	7.6	11.5	16	23	29	35	43	57	70	85	106	144	180	216	260	325
	ND (initial setting)	1.5	2.5	4	6	9	12	17	23	31	38	44	57	71	86	110	144	180	216	260
Overload current rating *3	LD	120% of rated motor capacity for 60 s, 150% of rated motor capacity for 3 s (max. surrounding air temperature 40°C)																		
	ND (initial setting)	150% of rated motor capacity for 60 s, 200% of rated motor capacity for 3 s (max. surrounding air temperature 40°C)																		
Rated voltage *4	Three-phase 380 to 500 V																			
Regenerative braking torque *5	10% torque/continuous																			
Rated input AC voltage/frequency	Three-phase 380 to 500 V 50 Hz/60 Hz *8																			
Permissible AC voltage fluctuation	323 to 550 V 50 Hz/60 Hz																			
Permissible frequency fluctuation	±5%																			
Rated input current [A] *6	LD	2.1	3.5	4.8	7.6	11.5	16	23	29	35	43	57	70	85	106	144	180	216	260	325
	ND (initial setting)	1.5	2.5	4	6	9	12	17	23	31	38	44	57	71	86	110	144	180	216	260
Power supply capacity [kVA] *7	LD	1.6	2.7	3.7	5.8	9	12	18	22	27	33	43	53	65	81	110	137	165	198	248
	ND (initial setting)	1.1	1.9	3	4.6	6.9	9	13	18	24	29	34	43	54	66	102	110	137	165	198
Protective structure	IEC 60529	Dust- and water-proof type (IP55) *10																		
	UL50	UL Type12 *9																		
Cooling system	Self-cooling + internal fan										Forced air cooling + internal fan									
Weight [kg]	15	15	15	15	16	17	26	26	27	27	59	60	63	64	147	150	153	189	193	

*1 The applicable motor capacity indicated is the maximum capacity applicable for use of the Mitsubishi Electric 4-pole standard motor.

*2 The rated output capacity indicated assumes that the output voltage is 440V.

*3 The % value of the overload current rating indicated is the ratio of the overload current to the inverter's rated output current. For repeated duty, allow time for the inverter and motor to return to or below the temperatures under 100% load.

*4 The maximum output voltage does not exceed the power supply voltage. The maximum output voltage can be changed within the setting range. However, the maximum point of the voltage waveform at the inverter output side is the power supply voltage multiplied by about $\sqrt{2}$.

*5 Value for the ND rating

*6 The rated input current indicates a value at a rated output voltage. The impedance at the power supply side (including those of the input reactor and cables) affects the rated input current.

*7 The power supply capacity is the value when at the rated output current. It varies by the impedance at the power supply side (including those of the input reactor and cables).

*8 For the power voltage exceeding 480V, set Pr. 977 "Input voltage mode selection". (For details, refer to the FR-A800 Instruction Manual.)

*9 UL Type 12 Enclosure-Suitable for Installation in a Compartment Handling Conditioned Air (Plenum)

*10 For compliance with IP55, remove the protective bushes and install the recommended cable glands.



7.2 Outline dimensions

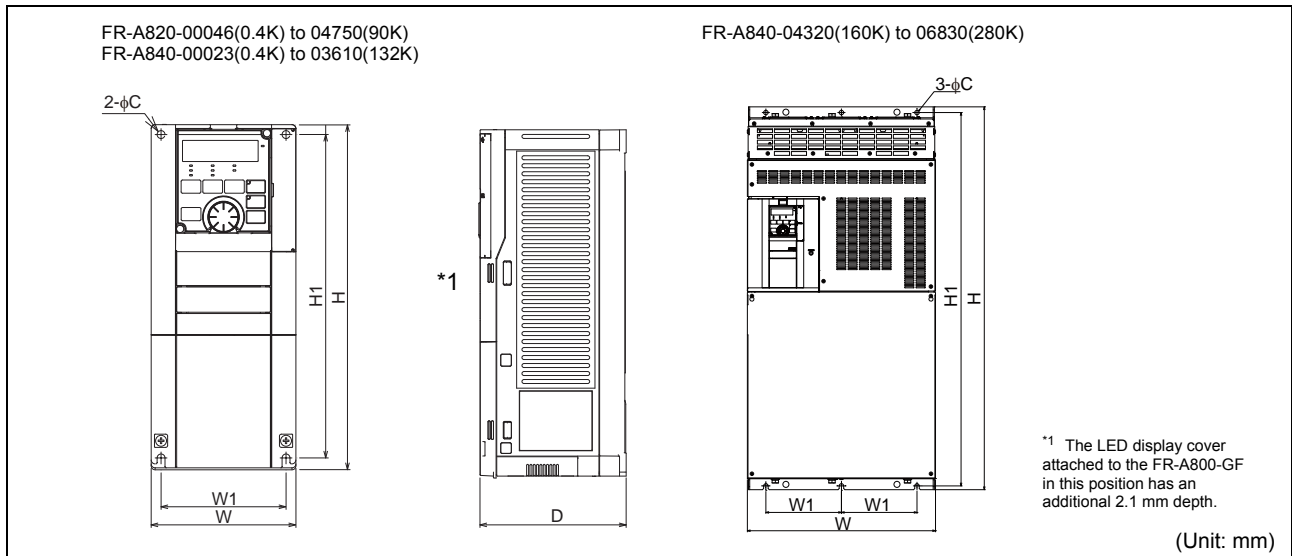

	Inverter type	W	W1	H	H1	D	C			
200 V class	FR-A820-00046(0.4K)	110	95	260	245	110	6			
	FR-A820-00077(0.75K)					125				
	FR-A820-00105(1.5K)	150	125			260		245	140	
	FR-A820-00167(2.2K)									
	FR-A820-00250(3.7K)									
	FR-A820-00340(5.5K)									
	FR-A820-00490(7.5K)	220	195	300	285	170				
	FR-A820-00630(11K)									
	FR-A820-00770(15K)	250	230	400	380	190		10		
	FR-A820-00930(18.5K)									
	FR-A820-01250(22K)									
	FR-A820-01540(30K)									
	FR-A820-01870(37K)	435	380	550	525	250		12		
	FR-A820-02330(45K)									
FR-A820-03160(55K)	465	400	700	675	360					
FR-A820-03800(75K)										
FR-A820-04750(90K)										
FR-A820-04750(90K)										
400 V class	FR-A840-00023(0.4K)	150	125	260	245	140	6			
	FR-A840-00038(0.75K)									
	FR-A840-00052(1.5K)									
	FR-A840-00083(2.2K)									
	FR-A840-00126(3.7K)									
	FR-A840-00170(5.5K)	220	195	300	285	170				
	FR-A840-00250(7.5K)									
	FR-A840-00310(11K)									
	FR-A840-00380(15K)									
	FR-A840-00470(18.5K)									
	FR-A840-00620(22K)	250	230	400	380	190	10			
	FR-A840-00770(30K)									
	FR-A840-00930(37K)									
	FR-A840-01160(45K)									
	FR-A840-01800(55K)	435	380	550	525	250	12			
	FR-A840-02160(75K)									
	FR-A840-02600(90K)									
	FR-A840-03250(110K)									
	FR-A840-03610(132K)	465	400	620	595	300				
	FR-A840-04320(160K)									
FR-A840-04810(185K)										
FR-A840-05470(220K)										
FR-A840-06100(250K)	680	300	740	715	360					
FR-A840-06830(280K)										
FR-A840-04320(160K)						498	200	1010	985	380
FR-A840-04810(185K)										
FR-A840-05470(220K)	680	300	1010	984	380					
FR-A840-06100(250K)										
FR-A840-06830(280K)										
FR-A840-06830(280K)										

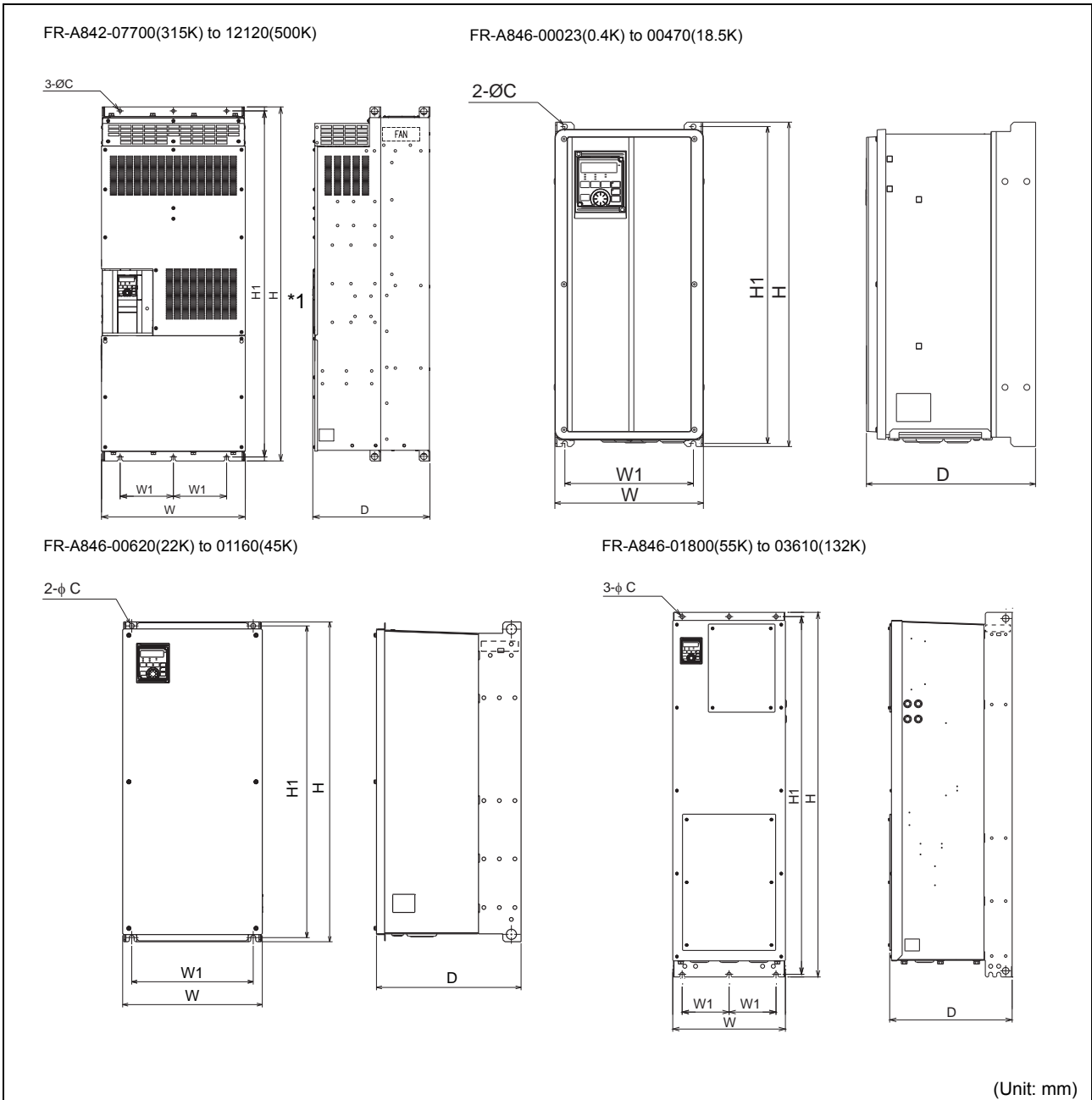

	Inverter type	W	W1	H	H1	D	C
400 V class	FR-A842-07700(315K)	540	200	1330	1300	440 *1	12
	FR-A842-08660(355K)						
	FR-A842-09620(400K)						
	FR-A842-10940(450K)						
	FR-A842-12120(500K)						
	FR-A846-00023(0.4K) to 00170(5.5K)	238	201	520	508	271	8
	FR-A846-00250(7.5K) to 00470(18.5K)			650	632.5	285	10
	FR-A846-00620(22K) to 01160(45K)	345	300	790	770	357	12
	FR-A846-01800(55K) to 02600(90K)	420	175	1360	1334	456,6	15
	FR-A846-03250(110K), 03610(132K)			1510	1482		

*1 The LED display cover attached to the FR-A800-GF in this position has an additional 2.5 mm depth.

For dimensions of the converter unit (FR-CC2) refer to the FR-CC2 Instruction Manual.

A APPENDIX

A.1 Instructions for Compliance with the EU Directives

The EU Directives are issued to standardize different national regulations of the EU Member States and to facilitate free movement of the equipment, whose safety is ensured, in the EU territory.

Since 1996, compliance with the EMC Directive that is one of the EU Directives has been legally required. Since 1997, compliance with the Low Voltage Directive, another EU Directive, has been also legally required. When a manufacturer confirms its equipment to be compliant with the EMC Directive and the Low Voltage Directive, the manufacturer must declare the conformity and affix the CE marking.

- The authorized representative in the EU
The authorized representative in the EU is shown below:
Name: Mitsubishi Electric Europe B.V.
Address: Mitsubishi-Electric-Platz 1, 40882 Ratingen, Germany

A.1.1 EMC Directive

We declare that this inverter conforms with the EMC Directive and affix the CE marking on the inverter.

- EMC Directive: 2004/108/EC
- Standard(s): EN61800-3:2004 (Second environment / PDS Category "C3")
Standards for IP55 compatible models: EN61800-3:2004 (First environment / PDS Category "C2",
Second environment / PDS Category "C3". The applicable standard depends on the built-in EMC filter.)
- This inverter is not intended to be used on a low-voltage public network which supplies domestic premises. When using the inverter in a residential area, take appropriate measures and ensure the conformity of the inverter used in the residential area.
- Radio frequency interference is expected if used on such a network.
- The installer shall provide a guide for installation and use, including recommended mitigation devices.

NOTES

- First environment
Environment including residential buildings. Includes buildings directly connected without a transformer to the low voltage power supply network which supplies power to residential buildings.
- Second environment
Environment including all buildings except buildings directly connected without a transformer to the low voltage power supply network which supplies power to residential buildings.

NOTES

Set the EMC filter valid and install the inverter and perform wiring according to the following instructions:

- The inverter (resp. the converter unit for separated converter types) is equipped with a built-in EMC filter. Set the EMC filter valid. (For details, refer to the FR-A800 and FR-CC2 Instruction Manuals.)
- FR-A800-E only: This inverter is equipped with an EMC filter with a class C3. Enable the EMC filter. (For details, refer to the FR-A800 Instruction Manual.)
- Connect the inverter (and the converter unit) to an earthed power supply.
- Install a motor and a control cable according to the EMC Installation Guidelines (BCN-A21041-204) and Technical News (MF-S-112, 113, 119) according to the instruction.
- Standard models only: The cable length between the inverter and the motor is 5 m maximum.
- FR-A800-E only: To ensure sufficient function of the built-in EMC filter, motor cable lengths should not exceed more than 20 m.
- Confirm that the inverter (and the converter unit) conforms with the EMC Directive as the industrial drives application for final installation.

- For IP55 compatible models:

If the inverter with a built-in Class C2 EMC filter has an input current of 16 A or less, limits for harmonic current emissions of EN/IEC61000-3-2 shall apply.

However, if the inverter is the professional equipment with a total rated power of 1 kW or higher, limits for harmonic current emissions of EN/IEC61000-3-2 shall not apply. If the equipment input current is more than 16 A and does not exceed 75 A, the equipment complies with EN/IEC61000-3-12 provided that the short-circuit power S_{sc} is greater than or equal to the value provided in the table below at the interface point between the user's supply and the public system. It is the responsibility of the installer or user of the equipment to ensure, by consultation with the distribution network operator if necessary, that the equipment is connected only to a supply with a short-circuit power S_{sc} greater than or equal to the value mentioned in the table below.

Inverter model	Standard	S_{sc}	R_{sce}
FR-A846-00023(0.4K)	EN/IEC61000-3-2	—	—
FR-A846-00250(7.5K)	EN/IEC61000-3-12	2261 kVA	≥ 120
FR-A846-00310(11K)		3059 kVA	
FR-A846-00380(15K)		4124 kVA	
FR-A846-00470(18.5K)		5055 kVA	
FR-A846-00620(22K)		5853 kVA	
FR-A846-00770(30K)		7582 kVA	
FR-A846-00930(37K)		9445 kVA	
FR-A846-01160(45K)		11440 kVA	
FR-A846-01800(55K)		14632 kVA	
FR-A846-02160(75K)		IEC61000-3-4	
FR-A846-02600(90K)	—		
FR-A846-03250(110K)	—		
FR-A846-03610(132K)	—		
	—		



A.1.2 Low Voltage Directive

We have self-confirmed our inverters as products compliant to the Low Voltage Directive (conforming standard EN 61800-5-1) and place the CE mark on the inverters.

Outline of instructions

- Do not use an earth leakage current breaker as an electric shock protector without connecting the equipment to the earth. Connect the equipment to the earth securely.
- Wire the earth terminal independently. (Do not connect two or more cables to one terminal.)
- Use the cable sizes on *page 26* under the following conditions.
 - Surrounding air temperature: 40°C maximum
 - If conditions are different from above, select appropriate wire according to EN60204 Appendix C TABLE 5.
- Use a tinned (plating should not include zinc) crimping terminal to connect the earth cable. When tightening the screw, be careful not to damage the threads.
For use as a product compliant with the Low Voltage Directive, use PVC cable whose size is indicated on *page 26*.
- Use the moulded case circuit breaker and magnetic contactor which conform to the EN or IEC Standard.
- This product can cause a DC current in the protective earthing conductor. Where a residual current-operated protective (RCD) or monitoring (RCM) device is used for protection in case of direct or indirect contact, only an RCD or RCM of Type B is allowed on the supply side of this product.
- Use the inverter under the conditions of overvoltage category II (usable regardless of the earth condition of the power supply), overvoltage category III (usable with the earthed-neutral system power supply, 400 V class only) and pollution degree 2 or lower specified in IEC60664. An insulating transformer needs to be installed in the input side of the FR-A820 series inverters.
 - To use the inverter FR-A820-01540(30K) or higher, the FR-A840-00770(30K) or higher (IP00) and the FR-A842 models under the conditions of pollution degree 2, install it in the enclosure of IP2X or higher.
 - To use the inverter under the conditions of pollution degree 3, install it in the enclosure of IP54 or higher (standard models and separated converter types only).
 - To use the inverter FR-A820-01250(22K) or less and FR-A840-00620(22K) or less (IP20) outside of an enclosure in the environment of pollution degree 2, fix a fan cover with fan cover fixing screws enclosed.

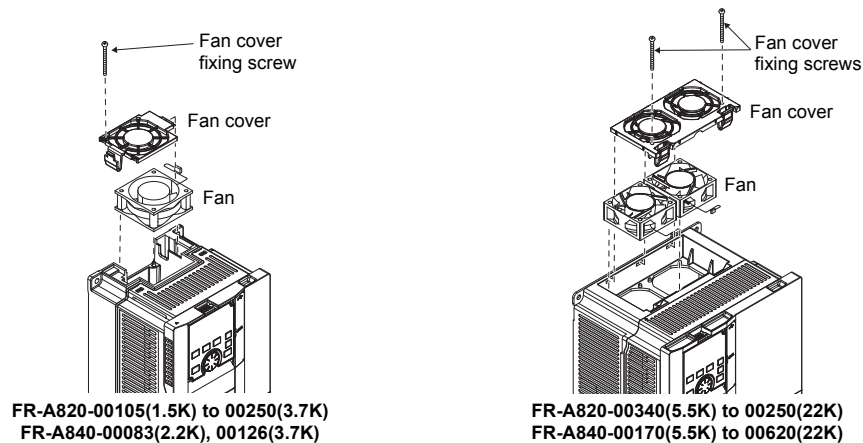

- On the input and output of the inverter (and the converter unit), use cables of the type and size set forth in EN 60204 Appendix C.
- The operating capacity of the relay outputs (terminal symbols A1, B1, C1, A2, B2, C2) should be 30 V DC, 0.3 A. (Relay outputs are basically isolated from the inverter internal circuit (and the converter unit).)
- Control circuit terminals on *page 4* are safely isolated from the main circuit.
- Environment (for details, refer to *page 2*)

	During operation	In storage	During transportation
Surrounding air temperature	LD, ND (initial setting), HD ratings: -10 to +50°C SLD rating: -10 to +40°C IP55 compatible models: -10 to +40°C	-20 to +65°C	-20 to +65°C
Ambient humidity	95% RH or less	95% RH or less	95% RH or less
Maximum altitude	2500 m	2500 m	10000 m

- For IP55 compatible models: Install the inverter at a place where ultraviolet radiation is not applied directly.

Wiring protection

For installation Class T, Class J, Class CC, or Class L fuse, or UL 489 Molded Case Circuit Breaker (MCCB) according to the local directives must be provided.

For the FR-A820 and FR-A846 series, Class T, Class J, or Class CC fuse, or UL 489 Molded Case Circuit Breaker (MCCB) must be provided.

FR-A820-□	00046 (0.4K)	00077 (0.75K)	00105 (1.5K)	00167 (2.2K)	00250 (3.7K)	00340 (5.5K)	00490 (7.5K)	00630 (11K)	00770 (15K)	00930 (18.5K)	01250 (22K)	01540 (30K)
Rated fuse voltage [V]	240 V or more											
Fuse maximum allowable rating [A] *1	Without power factor improving reactor	15	30	40	60	80	150	175	200	225	300	350
	With power factor improving reactor	15	20	20	30	50	70	125	150	200	200	250
Molded case circuit breaker (MCCB) Maximum allowable rating [A] *1	15	15	25	40	60	80	110	150	190	225	300	350

FR-A820-□	01870 (37K)	02330 (45K)	03160 (55K)	03800 (75K)	04750 (90K)	
Rated fuse voltage [V]	240 V or more					
Fuse maximum allowable rating [A] *1	Without power factor improving reactor	400	500	500	—	—
	With power factor improving reactor	350	400	500	600	700
Molded case circuit breaker (MCCB) Maximum allowable rating [A] *1	450	500	700	900	1000	

FR-A840-□	00023 (0.4K)	00038 (0.75K)	00052 (1.5K)	00083 (2.2K)	00126 (3.7K)	00170 (5.5K)	00250 (7.5K)	00310 (11K)	00380 (15K)	00470 (18.5K)	00620 (22K)	00770 (30K)	
Rated fuse voltage [V]	500 V or more												
Fuse maximum allowable rating [A] *1	Without power factor improving reactor	6	10	15	20	30	40	70	80	90	110	150	175
	With power factor improving reactor	6	10	10	15	25	35	60	70	90	100	125	150
Molded case circuit breaker (MCCB) Maximum allowable rating [A] *1	15	15	15	20	30	40	60	70	90	100	150	175	

FR-A840-□	00930 (37K)	01160 (45K)	01800 (55K)	02160 (75K)	02600 (90K)	03250 (110K)	03610 (132K)	04320 (160K)	04810 (185K)	05470 (220K)	06100 (250K)	06830 (280K)
Rated fuse voltage [V]	500 V or more											
Fuse maximum allowable rating [A] *1	Without power factor improving reactor	200	250	300	—	—	—	—	—	—	—	—
	With power factor improving reactor	175	200	250	300	350	400	500	600	700	800	900
Molded case circuit breaker (MCCB) Maximum allowable rating [A] *1	225	250	450	450	500	600	800	900	1000	1200	1200	1200

FR-A846-□	00023 (0.4K)	00038 (0.75K)	00052 (1.5K)	00083 (2.2K)	00126 (3.7K)	00170 (5.5K)	00250 (7.5K)	00310 (11K)	00380 (15K)	00470 (18.5K)	00620 (22K)	00770 (30K)
Rated fuse voltage [V]	500 V or more											
Fuse maximum allowable rating [A] *1	6	10	10	15	25	35	60	70	90	100	125	150
Molded case circuit breaker (MCCB) Maximum allowable rating [A] *1	15	15	15	20	30	40	60	70	90	100	150	175

FR-A846-□	00930 (37K)	01160 (45K)	01800 (55K)	02160 (75K)	02600 (90K)	03250 (110K)	03610 (132K)
Rated fuse voltage [V]	500 V or more						
Fuse maximum allowable rating [A] *1	175	200	250	300	350	400	500
Molded case circuit breaker (MCCB) Maximum allowable rating [A] *1	225	250	450	450	500	—	—

*1 Maximum allowable rating by US National Electrical Code. Exact size must be chosen for each installation.

For wiring protection of the converter unit (FR-CC2) refer to the FR-CC2 Instruction Manual.

A.1.3 Short circuit ratings

- 200 V class
Suitable for use in a circuit capable of delivering not more than 100 kA rms symmetrical amperes, 240 V maximum.
- 400 V class
Suitable for use in a circuit capable of delivering not more than 100 kA rms symmetrical amperes, 500 V maximum.

A.1.4 Machinery directive

The frequency inverter itself is not a machine in the spirit of the EU machinery directive. The start up of the frequency inverter in a machine is prohibited so long until it has been confirmed that the entire machine complies with the provisions of Directive 98/37/EC (from 29.12.2009 Machinery Directive 2006/42/EC).



A.2 Instructions for UL and cUL

(Conforming standard UL 508C, CSA C22.2 No.14)

A.2.1 General precautions

⚠ WARNING
The bus capacitor discharge time is 10 minutes. Before starting wiring or inspection, switch power off, wait for more than 10 minutes, and check for residual voltage between terminal P/+ and N/- with a meter etc., to avoid a hazard of electrical shock.

A.2.2 Installation

FR-A820/A840/A842 inverters

These types of inverter have been approved as products for use in enclosure and approval tests were conducted under the following conditions.

Design an enclosure so that the inverter surrounding air temperature, humidity and atmosphere satisfy the specifications. (Refer to *page 2*.)

FR-A846 inverters (IP55 compatible model)

These types of inverter have been approved as products for a UL type12 enclosure that is suitable for Installation in a Compartment Handling Conditioned Air (Plenum).

Install the inverter so that the inverter surrounding air temperature, humidity and atmosphere satisfy the specifications. (Refer to *page 2*.)

The drive must be installed in clean air according to enclosure classification.

Cooling air must be clean, free from corrosive materials and electrically conductive dust regarding the UL Type 12 enclosure.

This enclosure provides protection from airborne dust and light sprays or splashing water from all directions.

Wiring protection (FR-A820/A840 inverters)

For installation in the United States, Class T, Class J, Class CC, or Class L fuse, UL 489 Molded Case Circuit Breaker (MCCB), or Type E combination motor controller must be provided, in accordance with the National Electrical Code and any applicable provincial codes (refer to the tables on *page 71* and below).

For installation in Canada, Class T, Class J, Class CC, or Class L fuse, UL 489 Molded Case Circuit Breaker (MCCB) or Type E combination motor controller must be provided in accordance with the Canada Electrical Code and any applicable provincial codes (refer to the tables on *page 71* and below).

For the FR-A820 series, Class T, Class J, or Class CC fuse, UL 489 Molded Case Circuit Breaker (MCCB), or Type E combination motor controller must be provided (refer to the tables on *page 71* and below).

FR-A820-□		00046 (0.4K)	00077 (0.75K)	00105 (1.5K)	00167 (2.2K)	00250 (3.7K)	00340 (5.5K) or higher
Type E combination motor controller *1	Maximum current rating [A]	8	13	18	25	32	—
	Maximum SCCR [kA] *2	50	50	50	25	25	—

FR-A840-□		00023 (0.4K)	00038 (0.75K)	00052 (1.5K)	00083 (2.2K)	00126 (3.7K)	00170 (5.5K)	00250 (7.5K)	00310 (11K) or higher
Type E combination motor controller *1	Maximum current rating [A]	4	6.3	8	13	18	25	32	—
	Maximum SCCR [kA] *2	50	50	50	50	50	25	25	—

*1 For UL/cUL certification, use the following product:

Model	Manufacturer	Rated voltage, V AC
MMP-T32	Mitsubishi Electric Corp.	480Y/277

*2 Suitable for use in a circuit capable of delivering not more than 50 or 25 kA rms symmetrical amperes, 480Y/277 volts maximum when protected by the type E combination motor controllers indicated in the above table.

Wiring protection (FR-A842 inverters)

For wiring protection of the converter unit (FR-CC2) refer to the FR-CC2 Instruction Manual.

Wiring protection (FR-A846 inverters)

For installation in the United States, Class T, Class J, or Class CC fuse, or UL 489 Molded Case Circuit Breaker (MCCB) must be provided, in accordance with the National Electrical Code and any applicable local codes (refer to the tables on *page 71*).

For installation in Canada, Class T, Class J, or Class CC fuse, or UL 489 Molded Case Circuit Breaker (MCCB) must be provided, in accordance with the Canadian Electrical Code and any applicable local codes (refer to the tables on *page 71*).

A.2.3 Wiring of the power supply and motor

For wiring the input (R/L1, S/L2, T/L3) and output (U, V, W) terminals of the inverter use the UL-listed copper wires (rated at 75°C) and round crimping terminals. Crimp the crimping terminals with the crimping tool recommended by the terminal maker.

A.2.4 Short circuit ratings

- 200 V class
Suitable for use in a circuit capable of delivering not more than 100 kA rms symmetrical amperes, 240 V maximum.
- 400 V class
Suitable for use in a circuit capable of delivering not more than 100 kA rms symmetrical amperes, 500 V maximum.



A.2.5 Motor overload protection

When using the electronic thermal relay function as motor overload protection, set the rated motor current to Pr. 9 "Electronic thermal O/L relay".

Electronic thermal relay function operation characteristic

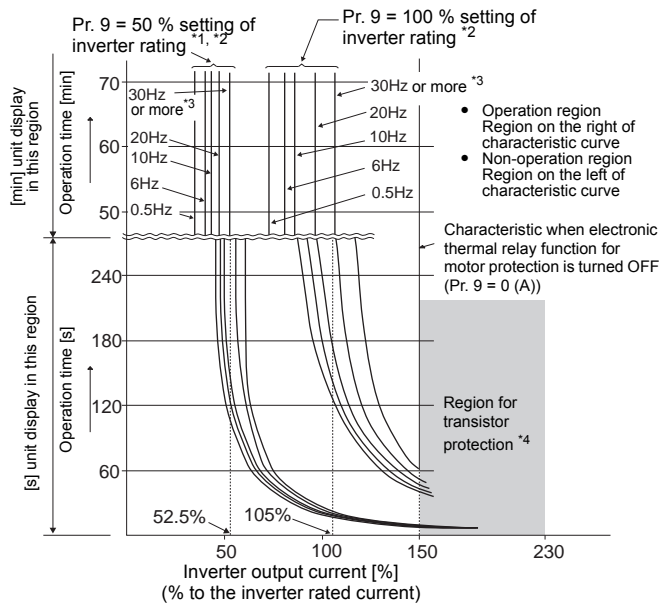

This function detects the overload (overheat) of the motor, stops the operation of the inverter's output transistor, and stops the output. (The operation characteristic is shown on the left.)

When using the Mitsubishi Electric constant-torque motor set one of "1", "13" to "16", "50", "53", "54" in Pr. 71. For FR-A842 models set one of "1", "13" to "16" in Pr. 71. This provides a 100 % continuous torque characteristic in the low-speed range. Set the rated current of the motor in Pr. 9.

^{*1} When 50% of the inverter rated output current (current value) is set in Pr. 9.

^{*2} The % value denotes the percentage to the inverter rated output current. It is not the percentage to the motor rated current.

^{*3} When you set the electronic thermal relay function dedicated to the Mitsubishi Electric constant-torque motor, this characteristic curve applies to operation at 6 Hz or higher.

^{*4} Transistor protection is activated depending on the temperature of the heatsink. The protection may be activated even with less than 150% depending on the operating conditions.

CAUTION

- The internal accumulated heat value of the electronic thermal relay function is reset by inverter power reset and reset signal input. Avoid unnecessary reset and power-OFF.
- When using multiple motors with one inverter, or using a multi-pole motor or a specialized motor, provide an external thermal relay (OCR) between the inverter and motor. And for the setting of the thermal relay, add the line-to-line leakage current to the current value on the motor rating plate (details in the FR-A800 Instruction Manual).
- For low-speed operation where the cooling capability of the motor reduces, it is recommended to use a thermal protector or thermistor-incorporated motor.
- When the difference between the inverter and motor capacities is large and the setting is small, the protective characteristics of the electronic thermal relay function will be deteriorated. In this case, use an external thermal relay.
- A special motor cannot be protected by the electronic thermal relay function. Use an external thermal relay.
- Standard models and IP55 compatible models only: Set Pr. 9 = "0" for vector-control-dedicated motors (SF-V5RU) because they are equipped with thermal protectors.
- Motor over temperature sensing is not provided by the drive.

HEADQUARTERS		EUROPEAN REPRESENTATIVES		EUROPEAN REPRESENTATIVES		EURASIAN REPRESENTATIVES	
Mitsubishi Electric Europe B.V. Mitsubishi-Electric-Platz 1 D-40882 Ratingen Phone: +49 (0)2102 / 486-0 Fax: +49 (0)2102 / 486-1120	EUROPE	GEVA Wiener Straße 89 A-2500 Baden Phone: +43 (0)2252 / 85 55 20 Fax: +43 (0)2252 / 488 60	AUSTRIA	INTEHSIS SRL bld. Traian 23/1 MD-2060 Kishinev Phone: +373 (0)22 / 66 4242 Fax: +373 (0)22 / 66 4280	MOLDOVA	TOO Kazpromavtomatika UL. ZHAMBYLA 28, KAZ-100017 Karaganda Phone: +7 7212 / 50 10 00 Fax: +7 7212 / 50 11 50	KAZAKHSTAN
Mitsubishi Electric Europe B.V. Pekařská 621/7 CZ-155 00 Praha 5 Phone: +420 255 719 200 Fax: +420 251 551 471	CZECH REP.	000 TECHNIKON Prospect Nezavisimosti 177-9 BY-220125 Minsk Phone: +375 (0)17 / 393 1177 Fax: +375 (0)17 / 393 0081	BELARUS	Fonseca S.A. R. João Francisco do Casal 87/89 PT-3801-997 Aveiro, Esqueiro Phone: +351 (0)234 / 303 900 Fax: +351 (0)234 / 303 910	PORTUGAL	MIDDLE EAST REPRESENTATIVE	
Mitsubishi Electric Europe B.V. 25, Boulevard des Bouvets F-92741 Nanterre Cedex Phone: +33 (0)1 / 55 68 55 68 Fax: +33 (0)1 / 55 68 57 57	FRANCE	INEA RBT d.o.o. Stegne 11 SI-1000 Ljubljana Phone: +386 (0)1 / 513 8116 Fax: +386 (0)1 / 513 8170	BOSNIA AND HERZEGOVINA	SIRIUS TRADING & SERVICES SRL Aleea Lacul Morii Nr. 3 RO-060841 Bucuresti, Sector 6 Phone: +40 (0)21 / 430 40 06 Fax: +40 (0)21 / 430 40 02	ROMANIA	ISRAEL	
Mitsubishi Electric Europe B.V. Westgate Business Park, Ballymount IRL-Dublin 24 Phone: +353 (0)1 4198800 Fax: +353 (0)1 4198890	IRELAND	AKHNATON 4, Andrei Ljapchev Blvd., PO Box 21 BG-1756 Sofia Phone: +359 (0)2 / 817 6000 Fax: +359 (0)2 / 97 44 06 1	BULGARIA	INEA SR d.o.o. Ul. Karadjordjeva 12/217 SER-11300 Smederevo Phone: +386 (026) 461 54 01	SERBIA	LEBANON	
Mitsubishi Electric Europe B.V. Viale Colleoni 7 Palazzo Sirio I-20864 Agrate Brianza (MB) Phone: +39 039 / 60 53 1 Fax: +39 039 / 60 53 312	ITALY	INEA CR Losinjka 4 a HR-10000 Zagreb Phone: +385 (0)1 / 36 940 - 01 / -02 / -03 Fax: +385 (0)1 / 36 940 - 03	CROATIA	SIMAP SK (Západné Slovensko) Dolné Pažite 603/97 SK-911 06 Trenčín Phone: +421 (0)32 743 04 72 Fax: +421 (0)32 743 75 20	SLOVAKIA	AFRICAN REPRESENTATIVE	
Mitsubishi Electric Europe B.V. Nijverheidsweg 23C NL-3641RP Mijdrecht Phone: +31 (0) 297 250 350	NETHERLANDS	AutoCont C. S. S.R.O. Kafkova 1853/3 CZ-702 00 Ostrava 2 Phone: +420 595 691 150 Fax: +420 595 691 199	CZECH REPUBLIC	INEA RBT d.o.o. Stegne 11 SI-1000 Ljubljana Phone: +386 (0)1 / 513 8116 Fax: +386 (0)1 / 513 8170	SLOVENIA	SOUTH AFRICA	
Mitsubishi Electric Europe B.V. ul. Krakowska 50 PL-32-083 Balice Phone: +48 (0) 12 347 65 00 Fax: +48 (0) 12 630 47 01	POLAND	HANS FØLSGAARD A/S Theilgaardstr Torv 1 DK-4600 Køge Phone: +45 4320 8600 Fax: +45 4396 8855	DENMARK	OMNI RAY AG Im Schörl 5 CH-8600 Dübendorf Phone: +41 (0)44 / 802 28 80 Fax: +41 (0)44 / 802 28 28	SWITZERLAND	ADROIT TECHNOLOGIES 20 Waterford Office Park 189 Witkoppen Road ZA-Fourways Phone: + 27 (0)11 / 658 8100 Fax: + 27 (0)11 / 658 8101	
Mitsubishi Electric (Russia) LLC 52, bld. 1 Kosmodamianskaya emb. RU-115054 Moscow Phone: +7 495 / 721 2070 Fax: +7 495 / 721 2071	RUSSIA	Electrobit OÜ Pärnu mnt. 160i EST-11317, Tallinn Phone: +372 6518 140	ESTONIA	CSC- AUTOMATION Ltd. 4 B, Yevhena Sverstyuka Str. UA-02002 Kiev Phone: +380 (0)44 / 494 33 44 Fax: +380 (0)44 / 494-33-66	UKRAINE		
Mitsubishi Electric Europe B.V. Carretera de Rubi 76-80 Apdo. 420 E-08190 Sant Cugat del Vallés (Barcelona) Phone: +34 (0) 93 / 5653131 Fax: +34 (0) 93 / 5891579	SPAIN	UTU Automation Oy Peltotie 37i FIN-28400 Ulvila Phone: +358 (0)207 / 463 500 Fax: +358 207 / 463 501	FINLAND				
Mitsubishi Electric Europe B.V. (Scandinavia) Hedvig Möllers gata 6, SE- 223 55 Lund Phone: +46 (0) 8 625 10 00	SWEDEN	UTECO A.B.E.E. 5, Mavrogenous Str. GR-18542 Piraeus Phone: +30 (0)211 / 1206-900 Fax: +30 (0)211 / 1206-999	GREECE				
Mitsubishi Electric Turkey Elektrik Ürünleri A.Ş. Fabrika Otomasyonu Merkezi Serifali Mahallesi Nutuk Sokak No.5 TR-34775 Ümraniye-İSTANBUL Phone: +90 (216) 969 25 00 Fax: +90 (216) / 526 39 95	TURKEY	MELTRADE Kft. Fertő utca 14. HU-1107 Budapest Phone: +36 (0)1 / 431-9726 Fax: +36 (0)1 / 431-9727	HUNGARY				
Mitsubishi Electric Europe B.V. Travellers Lane UK-Hatfield, Herts. AL10 8XB Phone: +44 (0)1707 / 28 87 80 Fax: +44 (0)1707 / 27 86 95	UK	OAK Integrator Products SIA Ritausmas iela 23 LV-1058 Riga Phone: +371 67842280	LATVIA				
Mitsubishi Electric Europe B.V. Dubai Silicon Oasis United Arab Emirates - Dubai Phone: +971 4 3724716 Fax: +971 4 3724721	UAE	Automatikos Centras, UAB Neries krantinė 14A-101 LT-48397 Kaunas Phone: +370 37 262707 Fax: +370 37 455605	LITHUANIA				
Mitsubishi Electric Corporation Tokyo Building 2-7-3 Marunouchi, Chiyoda-ku Tokyo 100-8310 Phone: +81 (3) 3218-2111 Fax: +81 (3) 3218-2185	JAPAN	ALFATRADE Ltd. 99, Paola Hill Malta-Paola PLA 1702 Phone: +356 (0)21 / 697 816 Fax: +356 (0)21 / 697 817	MALTA				
Mitsubishi Electric Automation, Inc. 500 Corporate Woods Parkway Vernon Hills, IL 60061 Phone: +1 (847) 478-2100 Fax: +1 (847) 478-0328	USA						