



Energy Measuring Unit Energy Measuring Standard Model  
Energy Measuring Unit Energy Measuring High Performance Model

**MODEL**

**EMU4-BM1-MB**

**EMU4-HM1-MB**

User's Manual (Details)

- Before operating the instrument, you should first read thoroughly this operation manual for safe operation and optimized performance of the product.  
Deliver this user's manual to the end user.





## Safety precautions

Thank you for purchasing the Energy Measuring Unit (EcoMonitorPlus).

- This manual describes setup and usage for the Energy Measuring Unit. Before using the product, please read this manual carefully to ensure correct use. Especially, in the case of where this unit is to be installed, please read "1. Precautions for Use" to ensure correct use.
- Make sure that the end users read this manual and then keep the manual in a safe place for future reference.
- Make sure to deliver this manual to the end-user.
- If you are considering using this unit for special purpose such as nuclear power plants, aerospace, medical care or passenger vehicles please refer to our sales representative.(For details, please see at the end of this manual.)

### ■ Notations in this manual

Use the following marks in this manual.

Mark	Meaning of the icons
 <b>Danger</b>	Indicates that incorrect handling may result in death or severe injury, ignoring this marking.
 <b>Caution</b>	Indicates that incorrect handling may result in injury or property damage, ignoring this marking.
 <b>Supplement</b>	Indicates that precautions to avoid a malfunction and to work the unit properly.
	Indicates that the pages described that related matters.

### ■ Checking package contents

This following items for this device and included in package. Check that no items are missing.

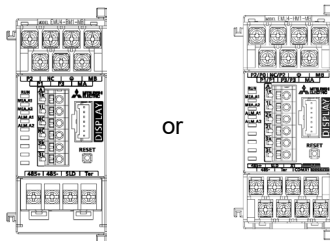

OR

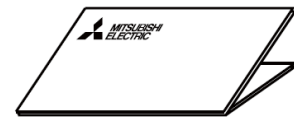

User's Manual (Digest) x1

Energy Measuring Unit x1

This unit cannot be used for deal and proof of electric energy measurement stipulated in the measurement law. Please use the certified watt-hour meter to be used for deal and proof of electric energy measurement stipulated.

### ■ Related materials

Refer to the following documents as necessary. You can download them from the Mitsubishi FA Global site.

Title	Ref. No.
Energy Measuring Unit EcoMonitorLight/EcoMonitorPlus Series MODBUS I/F Specification	LSPY-9025
Energy Measuring Unit Programming Manual (CC-Link) For ver.1 remote device station	LEN160305
Energy Measuring Unit Programming Manual (CC-Link) For ver.2 remote device station	LEN160316
Energy Measuring Unit Programming Manual (CC-Link IE Field Network Basic) (SLMP)	LEN180123

### ■ Trademark

- MODBUS is a trademark of Schneider Electric USA Inc.
- Other company and product names herein are trademarks or registered trademarks of their respective owners.
- In the text, trademark symbols such as "TM" and "®" may not be written.

## Feature

- This Energy Measuring unit can measure various types of electric quantity such as voltage, current, electric power and electric energy.
- The measured data can be sent to the high-end device, such as a monitoring device by MODBUS RTU communication function.
- This Energy Measuring unit has one external input terminal, which can switch between pulse input and contact input. Production quantity and water, gas, air (other than electricity) can be measured in the pulse input setting. (Model: EMU4-HM1-MB) Monitoring of condition and alarm, measurement of operating time and electric energy during operation can be done in the contact input setting.
- Adding this unit enables measurement of multiple circuits.
- For the single-phase 2-wire, this Energy Measuring Unit can measure two circuits of the system with the same voltage.
- This Energy Measuring unit can measure energy without input voltage by use the simple measuring function.

## Table of Content

<b>Safety precautions .....</b>	<b>1</b>
<b>Feature.....</b>	<b>1</b>
<b>Table of Content.....</b>	<b>1</b>
<b>1. Precautions for Use .....</b>	<b>3</b>
1.1 Precautions for Operating Environment and Conditions .....	3
1.2 Matters concerning the precaution before use.....	3
1.3 Installation and Wiring Precautions.....	3
1.4 Precautions for Use.....	4
1.5 Maintenance Precautions .....	4
1.6 Storage Precautions.....	4
1.7 Disposal Precautions .....	4
1.8 About packaging materials and this manual.....	4
<b>2. Disclaimer.....</b>	<b>5</b>
<b>3. Name and function of each part.....</b>	<b>5</b>
3.1 Name of each part.....	5
3.2 Indication and function of LEDs.....	6
3.3 2 circuits measuring in 1P2W .....	6
<b>4. Attaching and removing the unit .....</b>	<b>7</b>
4.1 Mounting on IEC rail.....	7
4.2 Mounting on JIS agreement type attachment .....	7
<b>5. Procedure for wiring .....</b>	<b>8</b>
5.1 Wiring for EMU4-BM1-MB.....	8
5.2 Wiring for EMU4-HM1-MB.....	10
5.3 Precautions for the connection wire .....	13
<b>6. Setting .....</b>	<b>18</b>
6.1 Setting data.....	18
6.2 Initialization of related item by changing the setup.....	23
<b>7. Operation .....</b>	<b>25</b>
7.1 Measurement.....	25
7.2 Upper/lower limit monitoring function.....	29
7.3 Simple measurement.....	32
<b>8. Device operation.....</b>	<b>36</b>
8.1 Resolution of measuring data.....	36
8.2 Restrictions of measured data .....	37
<b>9. Reference .....</b>	<b>38</b>
9.1 In case you think the unit is in failure .....	38
9.2 After-sales service .....	39
9.3 Q&A.....	39
<b>10. Requirement for the compliance with EMC Directives EMC .....</b>	<b>42</b>
<b>11. Specifications.....</b>	<b>43</b>
11.1 Common specifications.....	43
11.2 Specifications of MODBUS communications .....	45
<b>12. Option devices .....</b>	<b>46</b>
12.1 About option devices.....	46
12.2 Specifications of option devices .....	47
12.3 External dimensions of option devices .....	49
<b>13. External dimensions.....</b>	<b>57</b>
<b>14. Index.....</b>	<b>58</b>

# 1. Precautions for Use

## 1.1 Precautions for Operating Environment and Conditions

This unit is premised on being used in pollution degree 2 (Note 1) environment. When used in higher pollution degree, protect this unit from pollution on another device side to be incorporated.

Over voltage category of measuring circuit in this unit is CAT II (Note 1), and that of auxiliary power circuit (MA, MB) is CAT II (Note 1).

Do not use this product in the places listed below. Failure to follow the instruction may cause malfunctions and a life decrease of product.

- Places the Ambient temperature exceeds the range -5 - +55°C.
- Places the average daily temperature exceeds 35°C.
- Places the Relative humidity exceeds the range 30-85% or places with dewfall.
- Vibration and impact exceed the specifications.
- Dust, corrosive gas, saline and oil smoke exist.
- Places exposed to direct sunlight.
- Places exposed to rain or water drop.
- Places in strong electromagnetic field or places large amounts of external noise exist.
- Places metal fragments or conductive substances are flying.
- Altitude exceeds 2000m.

Note 1: For the definition of the pollution degree and the over voltage category, refer to EN61010-1/2010.

## 1.2 Matters concerning the precaution before use

- Use the unit in the specified usage environment and conditions.
- To set this unit, dedicated small-size display unit (EMU4-D65) is necessary. For the setting method, refer to User's manual (Details) of the display unit.

## 1.3 Installation and Wiring Precautions

 <b>Danger</b>	<ul style="list-style-type: none"><li>▪ <b>Shut off the external power supply for the unit in all phases before installing or wiring. Failure to do so may cause an electric shock or damage of this unit.</b></li><li>▪ <b>Work under the electric outage condition when installing and wiring. Failure to do so may cause electric shock, a failure of the unit, a fire etc.</b></li></ul>
---	--

### **Caution**

<Precautions for Electric work>

- Any person who is involved in the installation and the wiring of this unit should be fully competent to do this work.
- Keep the space around this product (all directions except the back) is 30 mm or more (100 mm or more for UL standard compliance).
- When tapping or wiring, take care not to entering any foreign objects such as chips and wire pieces into this unit.
- Check the connection diagram when wiring. Wrong wiring may cause failure of the unit, a fire or electric shock.
- For protection against noise, **transmission lines and input/output lines shall not be placed close to or bound together with the power lines and high-voltage lines.**
- The wires to be connected to this unit shall be placed in a duct or fixed together by cramping. If the electric wires are not placed in the duct or cramped together, loosen wires or their movement or careless stretch may cause a breakage of the unit or wire or a malfunction due to poor contact of electric wires.
- If transmission lines and input/output lines are placed close to or bound together with the power lines and high-voltage lines, keep distance as below between them.(Except for the input side of terminal block) If there is concern about the influence of noise even if the distance is as follows, we recommend using a shielded cable.

Condition	Distance
Power line 600V or less	300mm or longer
Other power line	600mm or longer

<Connection of terminal block>

- Strip the wires with proper length. Overlong stripping length may cause short to next wire. Shorter stripping length may cause contact failure.
- Take care not to short to next terminal by a filament. (Do not plate the wires with solder.)
- Do not connect three or more wires to one terminal of a terminal block for preventing loose contact and wires dropout.
- Use appropriate size of electric wires. If inappropriate size of electric wire is used, it may cause a fire due to generated heat.
- Tighten the screw within the specified torque. Under tightening can cause drop of the screw, short circuit or malfunction. Over tightening can damage the screw and/or unit, resulting in drop, short circuit or malfunction.
- After tightening the screws, be sure to check all the screws tightened. Loose screw may cause malfunction of the unit, a fire or electric shock.
- Be sure to attach the terminal cover to prevent electric shock.
- Use the crimp-type terminal appropriated for the size of electric wires. If inappropriate crimp-type terminal is used, a wire breakage or a contact failure may occur, which may cause a device malfunction, a failure, a burnout or a fire.
- Frame GND terminal must be grounded according to the D-type ground (ground resistance is not exceed 100Ω).
- Do not directly touch any conductive part of the unit. Doing so can cause electric shock, failure or malfunction of the unit.
- Do not input voltage and current at NC terminals. Doing so can cause failure or malfunction of the unit.

<Connection with the current sensor>

- When using this product, make sure to use it in combination with current sensor (EMU-CT\*\*, EMU-CT\*\*-A, EMU2-CT5 and EMU2-CT5-4W). This product cannot connect with the secondary side (5A) of current transformer. Please not to exceed the rating of this product for input of current sensor. For further details, please refer to current sensor manual to maintain the functionality and the accuracy of this product.
- The dedicated current sensor (EMU-CT\*\*, EMU-CT\*\*-A) is used only for low voltage circuit. It cannot be used for a high voltage circuit. EMU2-CT5 and CT5-4W should be used with the secondary side (5A) of transformer transfixed. If it is connected with a high-voltage circuit by mistake, it may cause a burnout of the device and a fire. It is critically dangerous. For the allowable maximum voltage of current sensor, refer to "12. Option devices" in this manual.
- The dedicated current sensor has a polarity (directionality). Be careful about it when installing the unit.
- If the wires connected to this unit are strongly pulled off, it may cause a malfunction or a breakage to the unit or the wire.

<Connection of frame GND terminal>

- Do not exceed the specified voltage when doing an insulation resistance test and a commercial frequency withstand voltage test.
- Frame FG terminal must be grounded according to the D-type ground.
- To prevent persons with little knowledge about electric equipment from electric shock, panel must be taken either following measure.  
Lock the panel so that only those who get an education about electric equipment and have sufficient knowledge can unlock, or shut off power supply automatically by opening the panel.  
Cover the dangerous part of this unit.

## 1.4 Precautions for Use

- **This unit cannot be used for deal and proof of electric energy measurement stipulated in the measurement law.**
- Before operating the product, check that active bare wire and so on does not exist around the product. If any bare wire exists, stop the operation immediately, and take an appropriate action such as isolation protection.
- In the event of a power outage during the setting by Display unit / Communication line, the Energy Measuring unit is not set correctly. Please set again after power recovery.

### Caution

- Do not disassemble or modify this unit. It may cause failure, malfunction, injury or fire.
- Use this unit within the ratings specified in this manual. If it is used outside the ratings, it may cause not only malfunction or failure but also fire burnout.
- The secondary side of the models EMU2-CT5, EMU-CT50, EMU-CT100, EMU-CT250, EMU-CT50-A, EMU-CT100-A, EMU-CT250-A, EMU-CT400-A, EMU-CT600-A is equipped with the protective circuit against opening of secondary terminals. Opening them during the wiring work causes no problems. However, for safety, please do not continuously energize the module with the terminals open.
- The current sensors dedicated to this unit EMU-CT400/600 resemble the split current transformer for general gauges CW-5SL closely in appearance. However, characteristics are completely different. Be sure to connect the dedicated current sensor. Connecting CW-5SL to this unit directly may cause failure of the device, a burnout or a fire.
- Push the RESET switch with an appropriate force (1.6N). The addition of force than necessary, it may cause a malfunction or failure of the Unit.

## 1.5 Maintenance Precautions

- Use a soft dry cloth to clean off dirt of the unit surface. Do not let a chemical cloth remain on the surface for an extended period of time nor wipe the surface with thinner or benzene.
- Check for the following items to use this unit properly for long time.
  - (1) Daily maintenance
    - (a) No damage on this unit
    - (b) No abnormality with LCD indicators
    - (c) No abnormal noise, smell or heat
  - (2) Periodical maintenance (Once every 6 months to 1 year)
    - No looseness with installation and wire connection

### Caution

Do periodical maintenance under the electric outage condition. Failure to do so may cause electric shock, failure of the unit or a fire. Tighten the terminal regularly to prevent a fire.

## 1.6 Storage Precautions

- To store this unit, turn off the power and remove wires, and put it in a plastic bag.
- For long-time storage, avoid the following places. Failure to follow the instruction may cause a failure and reduced life of the unit.
  - Places the Ambient temperature exceeds the range -10 - +60°C.
  - Places the average daily temperature exceeds 35°C.
  - Places the Relative humidity exceeds the range 30-85% or places with dewfall.
  - Vibration and impact exceed the specifications.
  - Dust, corrosive gas, saline and oil smoke exist.
  - Places metal fragments or conductive substances are flying.
  - Place where metallic particles or inductive substances are dispersed

## 1.7 Disposal Precautions

When disposing of this unit, treat it as industrial waste.

## 1.8 About packaging materials and this manual

For reduction of environment load, packaging materials are produced with cardboard, and this manual is printed on recycled paper.

## 2. Disclaimer

- It is prohibited to reprint or copy all contents of this document in any form without our permission.
- The contents of this document will be updated to follow revisions to software and hardware, however under unavoidable circumstances it may not be synchronized.

## 3. Name and function of each part

### 3.1 Name of each part

(1) EMU4-BM1-MB

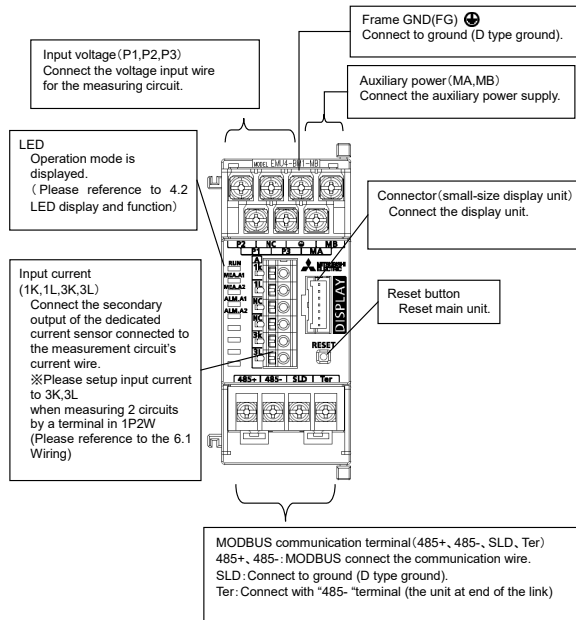

(2) EMU4-HM1-MB

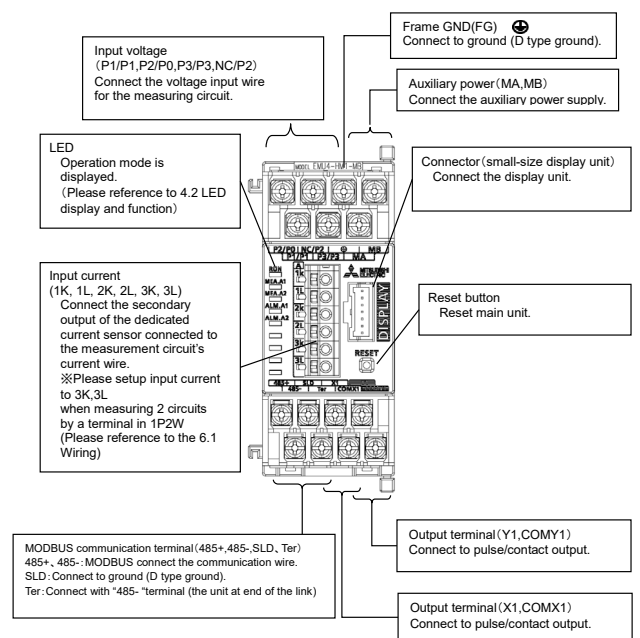

(3) Back view and side view

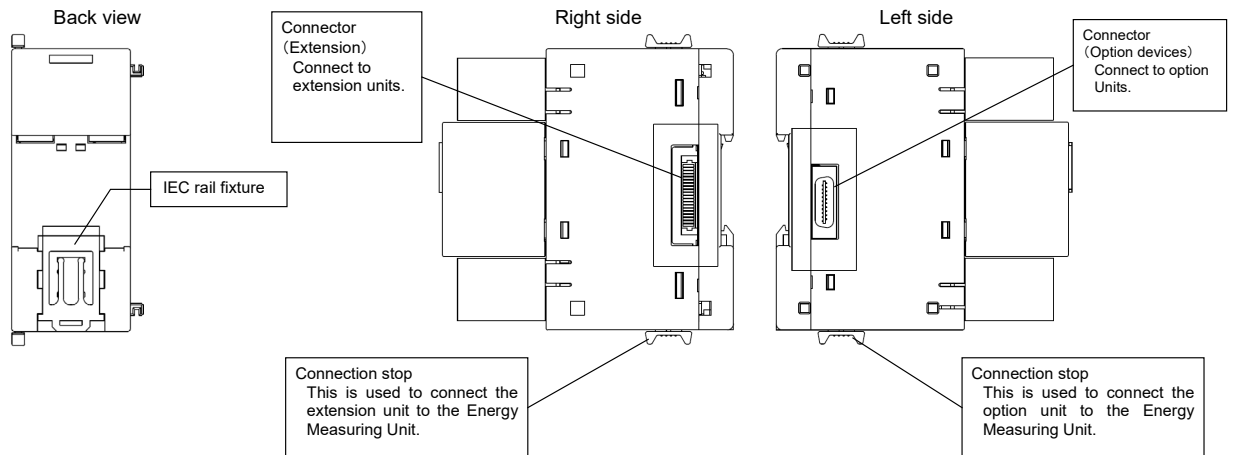

### 3.2 Indication and function of LEDs

The names and operations of LEDs are as follows.

Name	Color	Function	Status
RUN LED	Red	Indicate operating status of this unit.	ON: Normal condition OFF: Power off or hardware failure (Note 1)
MEA. A1 LED	Red	Indicate measuring status of the circuit A1.	ON: In the middle of measuring OFF: Halting measurement
MEA. A2 LED (Note 2)	Red	Indicate measuring status of the circuit A2.	ON: In the middle of measuring OFF: Halting measurement
ALM. A1 LED	Red	Indicate occurrence status of upper/lower limit alert of the circuit A1.	ON: An error occurs (Note 1) Blink: Upper/lower limit alert is issued OFF: No alert
ALM. A2 LED (Note 2)	Red	Indicate occurrence status of upper/lower limit alert of the circuit A2.	ON: An error occurs (Note 1) Blink: Upper/lower limit alert is issued OFF: No alert

(Note 1) For details, refer to Chapter 14 "Error codes" of "User's Manual (Details)".

(Note 2) Only in the case of single-phase 2-wire system, these indicate the status of the measured circuit of the current sensor in No.1 side of the circuit A2. (See 3.3)

### 3.3 2 circuits measuring in 1P2W

This unit can measure 2 circuits in the case wiring type 1P2W.

It is a function to measure the 1P2W of 1-N and 3-N branched from 1P3W. (Reference to Figure 3.3.2)

2 circuits measuring can be conducted when current sensor is connected to 1 side (1K, 1L) and 3 side (3K, 3L). (Reference to Figure 3.3.1 and 3.3.2)

Please reference to 5 chapter about wiring.

Please reference to 6.1 section and EMU4-D65 User's Manual (Details) when setup for measuring 2 circuits  
You can only measure same primary current value in 1 side and 3 side when 2 circuit measuring mode.

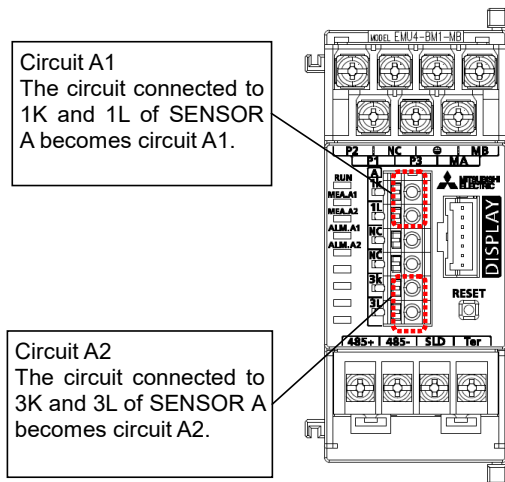

Figure3.3.1

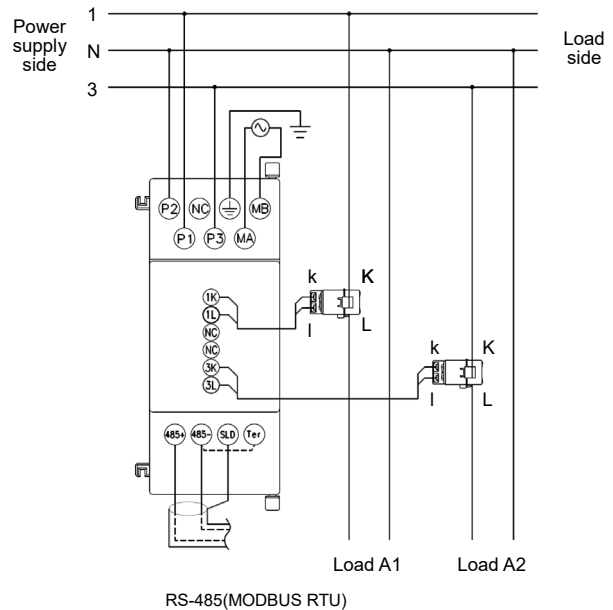

Figure3.3.2

## 4. Attaching and removing the unit

### ⚠ Caution

• Any person who is involved in the installation and the wiring of this unit should be fully competent to do this work.

#### 4.1 Mounting on IEC rail

- Applicable IEC rail (35mm)

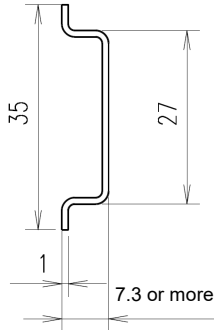

- Mounting

(1) Pull IEC rail fixture downward

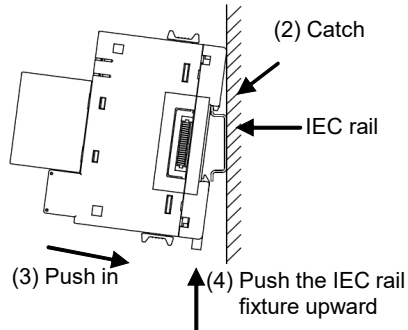

- Removing

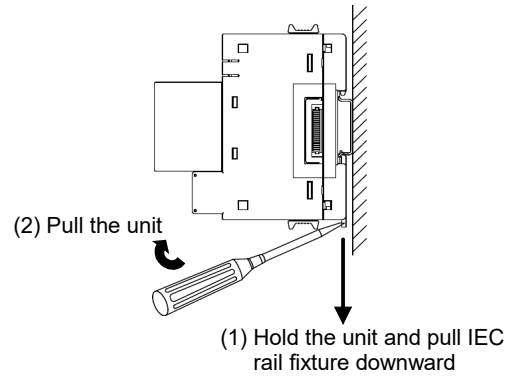

#### 4.2 Mounting on JIS agreement type attachment

- JIS agreement type attachment

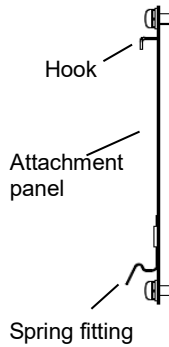

- Mounting

(1) Push the stopper of the IEC rail above

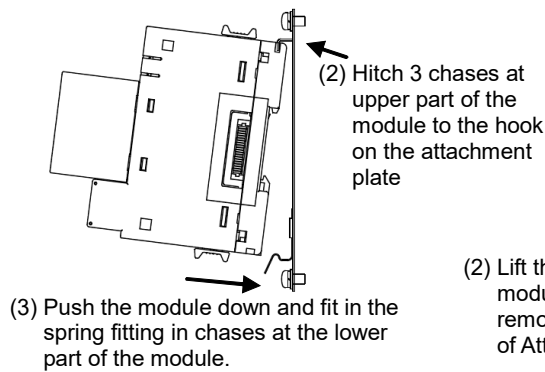

- Removing

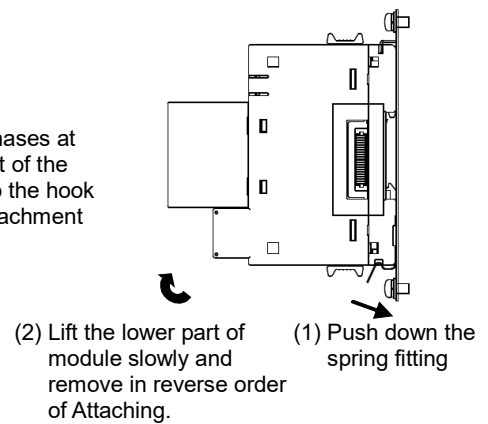



## 5. Procedure for wiring

Follow the wiring diagram for external connections of this unit.

To use this unit, Base unit (EMU4-BM1-MB, EMU4-HM1-MB, EMU4-LG1-MB) is necessary.

When using this unit, current sensor (EMU-CT\*\*\*, EMU-CT\*\*\*-A, EMU2-CT5 or EMU2-CT5-4W) is necessary

(Note) "\*\*\*\*" indicates the rated current of the current sensor (50/100/250/400/600).

Please do not use EMU-CT\*\*\* type sensor and EMU-CT\*\*\*-A type sensor with mixture.

### 5.1 Wiring for EMU4-BM1-MB

When UL compliance is unnecessary			When UL compliance is necessary		
Usable current sensor			Usable current sensor		
Models	Support	remark	Models	Support	remark
EMU-CT50	○	Connection with general wire	EMU-CT50	○	Connection with general wire
EMU-CT100	○		EMU-CT100	○	
EMU-CT250	○		EMU-CT250	○	
EMU-CT400	○		EMU-CT400	×	
EMU-CT600	○		EMU-CT600	×	
EMU-CT5-A	○		EMU-CT5-A	×	
EMU-CT50-A	○		EMU-CT50-A	×	
EMU-CT100-A	○		EMU-CT100-A	×	
EMU-CT250-A	○		EMU-CT250-A	×	
EMU-CT400-A	○		EMU-CT400-A	○	
EMU-CT600-A	○		EMU-CT600-A	○	
EMU2-CT5	○	Connection with dedicated cable	EMU2-CT5	○	Connection with dedicated cable
EMU2-CT5-4W	×*1		EMU2-CT5-4W	×*1	

\*1: EMU2-CT5-4W is only used 3phase-4wire system.

1P2W

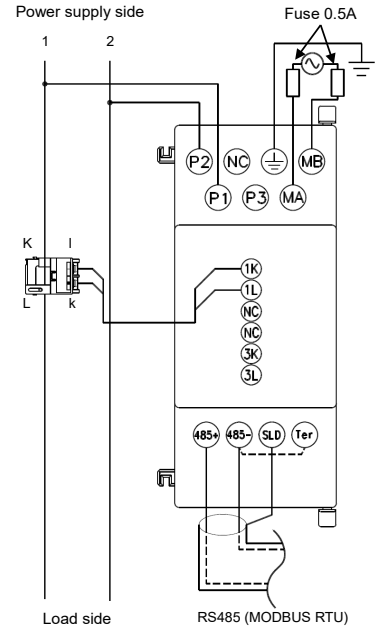
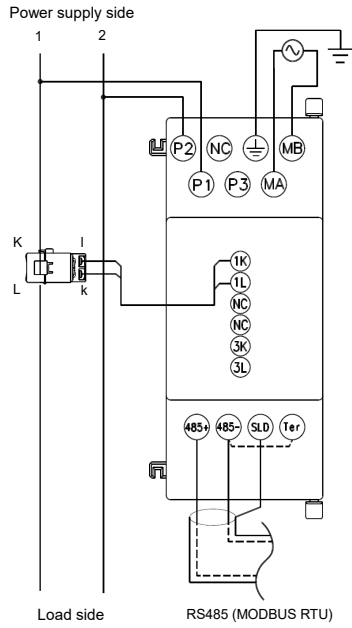

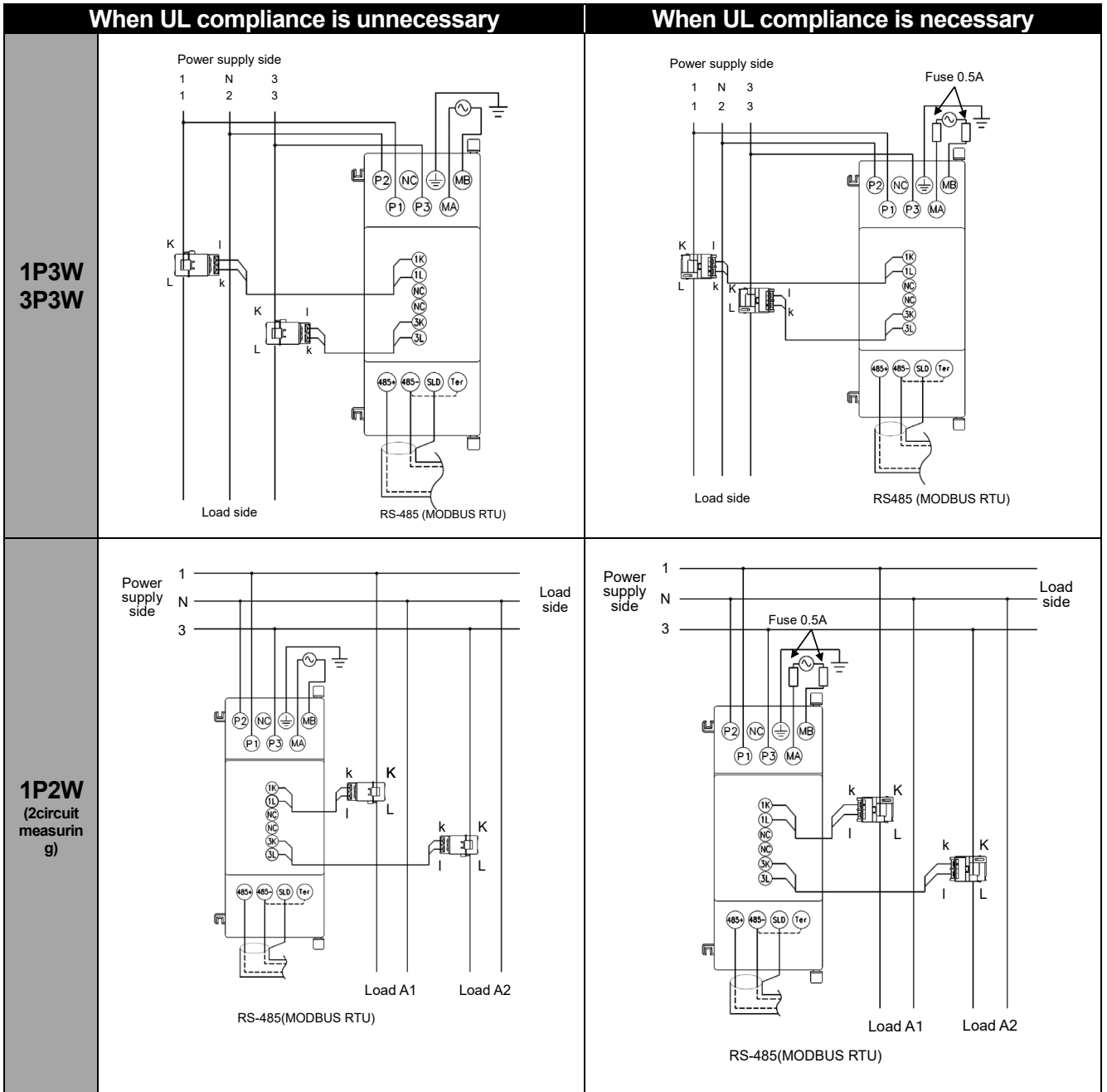

When UL compliance is unnecessary			When UL compliance is necessary		
Usable current sensor			Usable current sensor		
Models	Support	remark	Models	Support	remark
EMU-CT50	○	Connection with general wire	EMU-CT50	○	Connection with general wire
EMU-CT100	○		EMU-CT100	○	
EMU-CT250	○		EMU-CT250	○	
EMU-CT400	○		EMU-CT400	×	
EMU-CT600	○		EMU-CT600	×	
EMU-CT5-A	○		EMU-CT5-A	×	
EMU-CT50-A	○		EMU-CT50-A	×	
EMU-CT100-A	○		EMU-CT100-A	×	
EMU-CT250-A	○		EMU-CT250-A	×	
EMU-CT400-A	○		EMU-CT400-A	○	
EMU-CT600-A	○	EMU-CT600-A	○		
EMU2-CT5	○	Connection with dedicated cable	EMU2-CT5	○	Connection with dedicated cable
EMU2-CT5-4W	○		EMU2-CT5-4W	○	

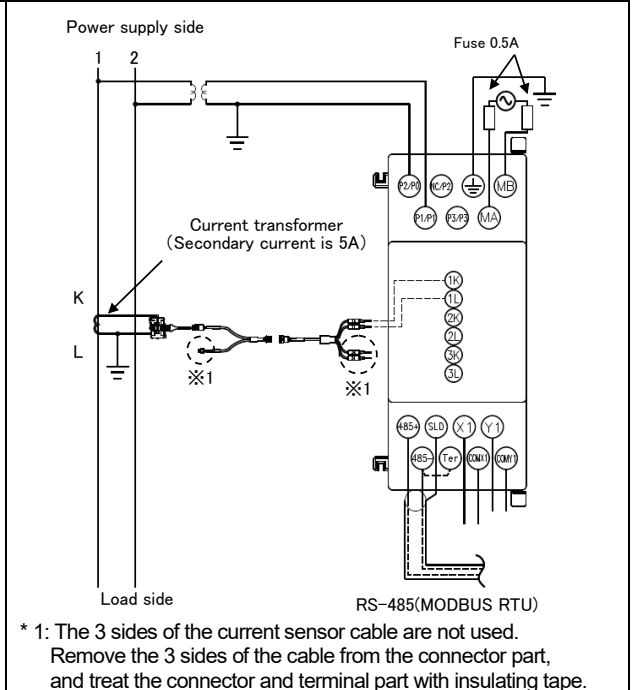
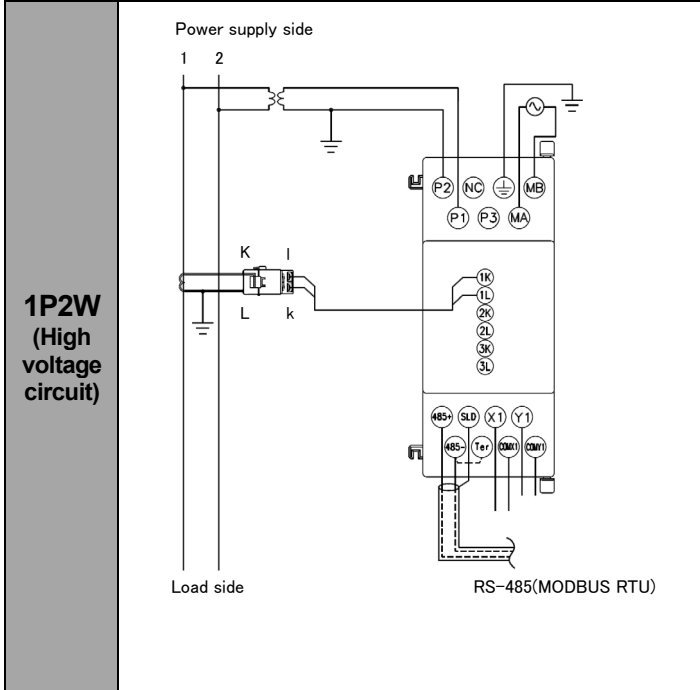
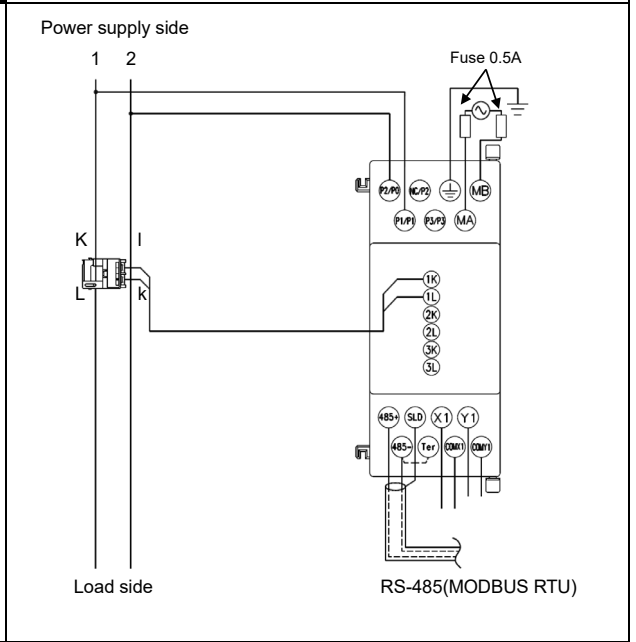
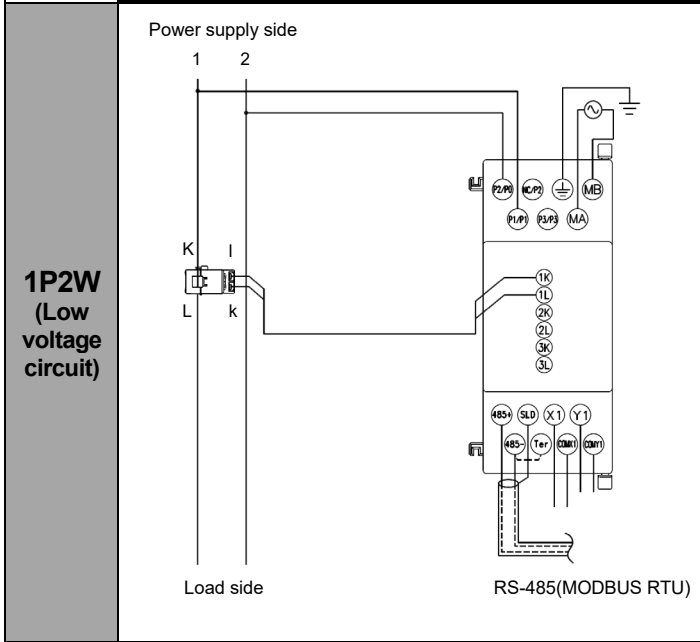

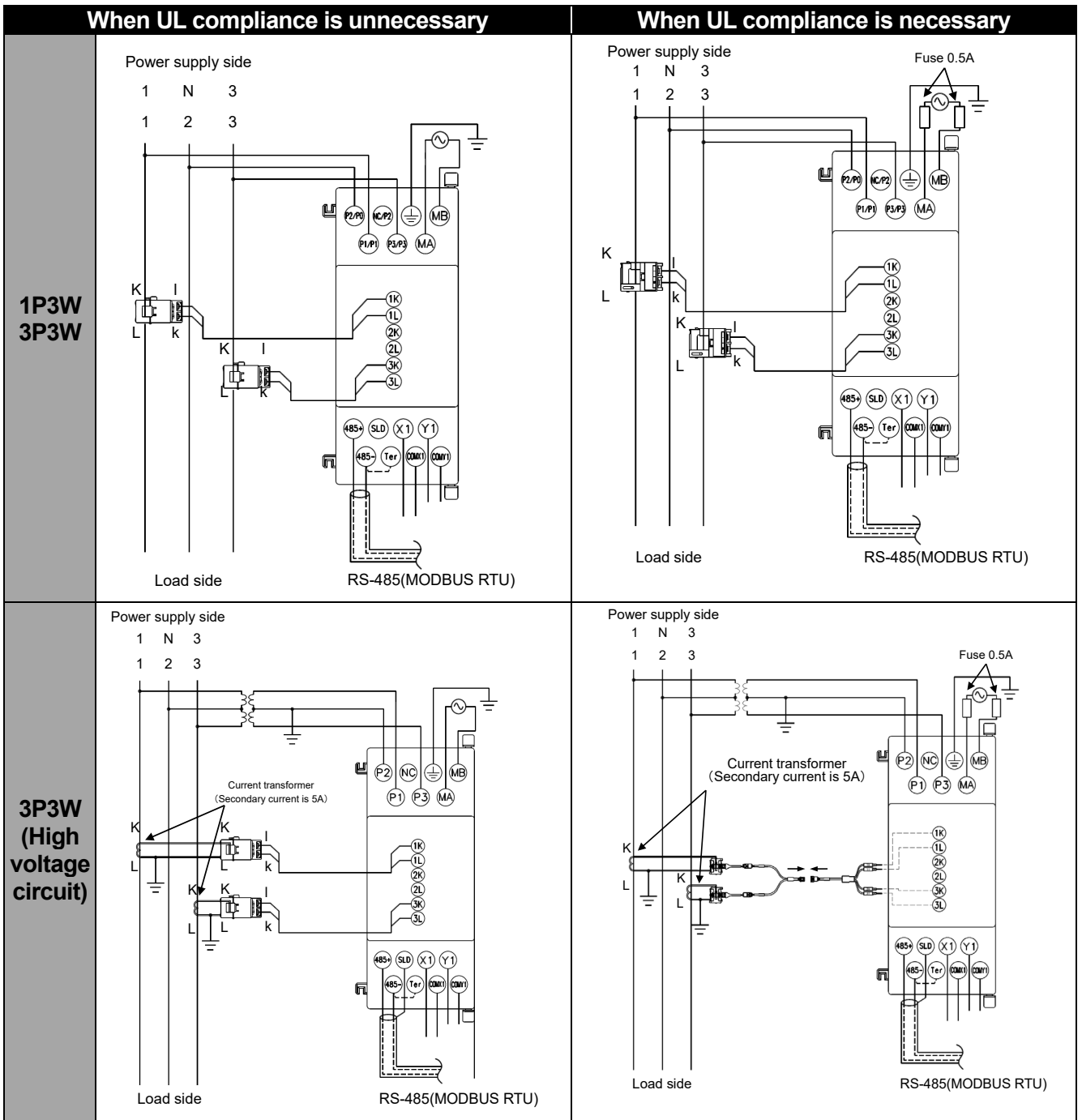

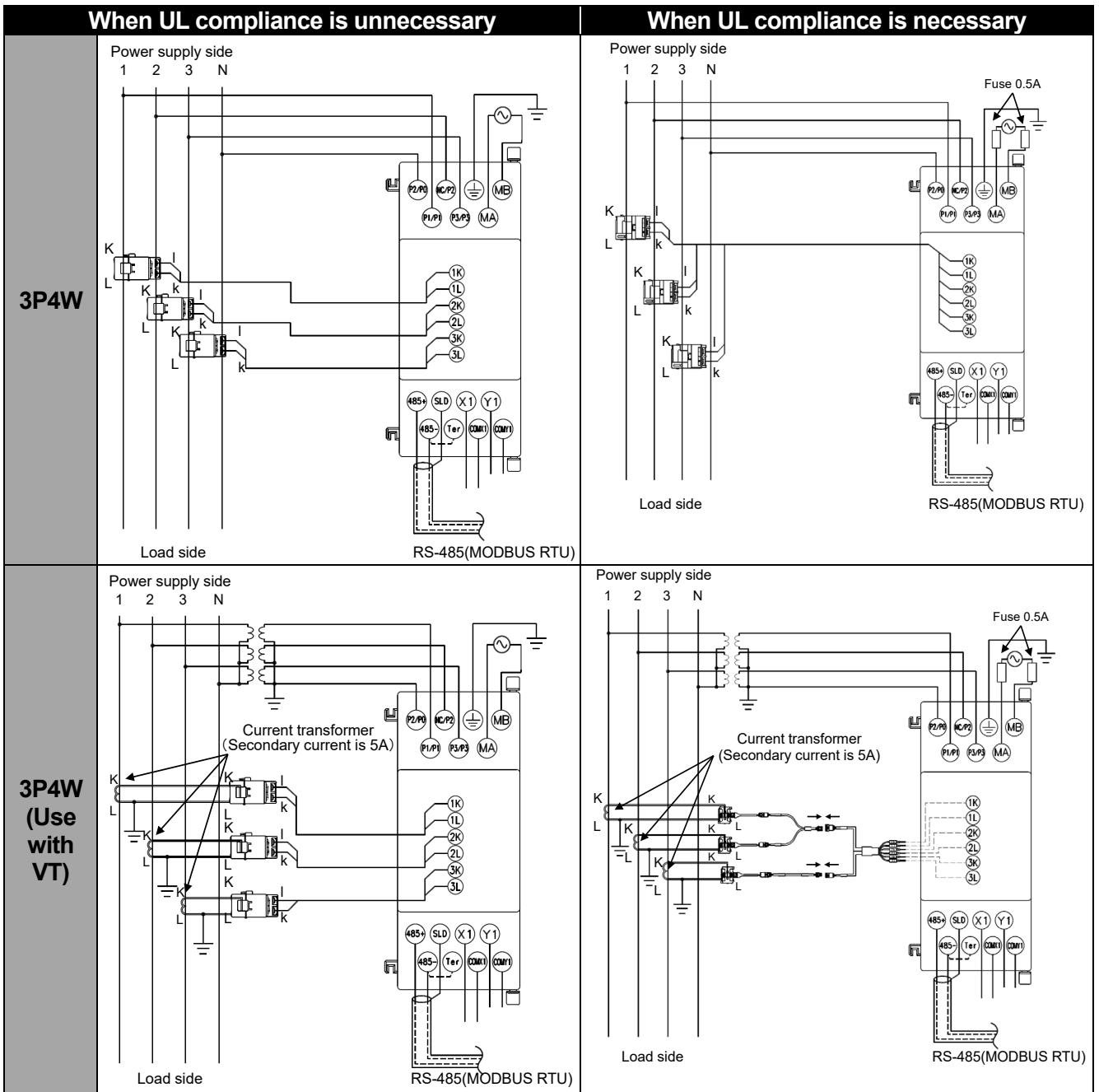

### 5.3 Precautions for the connection wire

<b>⚠ Caution</b>	<ul style="list-style-type: none"> <li>For protection against noise, transmission lines and input/output lines shall not be placed close to or bound together with the power lines and high-voltage lines. Keep distance as below between them. (except for the terminal block) If there is concern about the influence of noise even if the distance is as follows, we recommend using a shielded cable.</li> </ul>						
	<table border="1"> <thead> <tr> <th>Condition</th> <th>Distance</th> </tr> </thead> <tbody> <tr> <td>High-voltage line 600V or less</td> <td>300mm or more</td> </tr> <tr> <td>Other high-voltage line</td> <td>600mm or more</td> </tr> </tbody> </table>	Condition	Distance	High-voltage line 600V or less	300mm or more	Other high-voltage line	600mm or more
	Condition	Distance					
	High-voltage line 600V or less	300mm or more					
Other high-voltage line	600mm or more						
<ul style="list-style-type: none"> <li>For the actual usage, connect the FG terminal to ground. (D-type ground: Type 3) Connect it directly to the ground terminal.</li> <li>Do not connect to FG terminal during the insulation resistance test and pressure test. Refer to "User's manual (Details)" Chapter 11 "Specifications" for the applying place.</li> <li>The current sensors dedicated to this unit EMU-CT400/600 resemble the split current transformer for general gauges CW-5SL closely in appearance. However, characteristics are completely different. Be sure to connect the dedicated current sensor. Connecting CW-5SL to this unit directly may cause failure of the device, a burnout or a fire.</li> </ul>							

- Maximum voltage of the circuit connected to EMU4-BM1-MB is 260V, EMU4-HM1-MB is 480 (In 3P4W wiring is 277 / 480V). For the circuit over this voltage, use the transformer. Using the transformer, primary voltage is configurable up to 11000V. Secondary voltage can be set up to 220V.)
- Make sure that before connecting the cable, the orientation of the current sensor is correct for attachment. K to L is the correct direction. K: power source side, L: load side
- EMU-CT\*\*\* and EMU-CT\*\*\*-A are extendable up to 50m.
- EMU2-CT5 and EMU2-CT5-4W are extendable up to 11 m, using together with an extension cable. To extend the wire further, use the current transformer CW-5S(L) for split-type instrument in combination, extending the secondary wiring on CW-5S(L) side.
- EMU-CT\*\*\* and EMU-CT\*\*\*-A are used only for low voltage circuit. It cannot be used for a high voltage circuit. EMU2-CT5 and EMU2-CT5-4W should be used with the secondary side (5A) of transformer transfixed. If they are used for the circuit directly, they should be used under 200V.
- Do not ground the secondary side of the current sensor.
- Connect the k and l terminals on the secondary side of current sensor to the 1k and 1l (2k,2l,3k,3l) terminals of the measuring unit.
- EMU2-CT5 and EMU2-CT5-4W can be extended as follows.

(1) When extending EMU2-CT5 with a current sensor extension cable: EMU2-CB-T \*\* M (You can extend up to 11m with extension cable)

① Remove the connector.

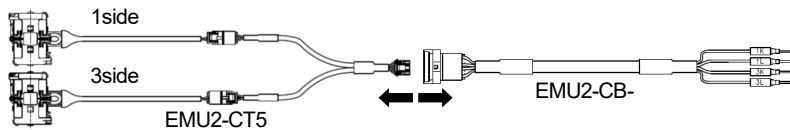

② Connect the current sensor extension cable.

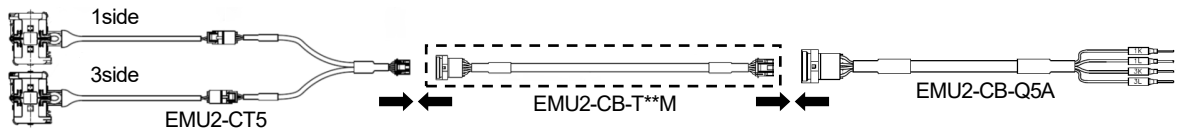

(2) When extending EMU2-CT5-4W with a current sensor extension cable: EMU2-CB-T \*\* M and EMU2-CB-T \*\* MS (You can extend up to 11m with extension cable)

① Remove the connector.

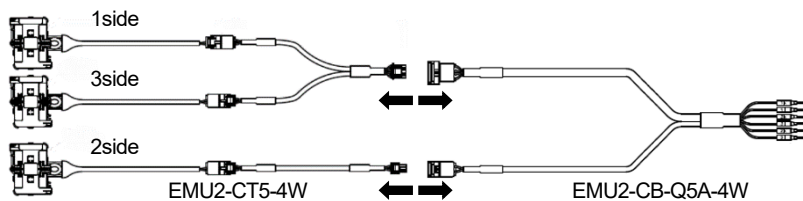

② Connect the current sensor extension cable.

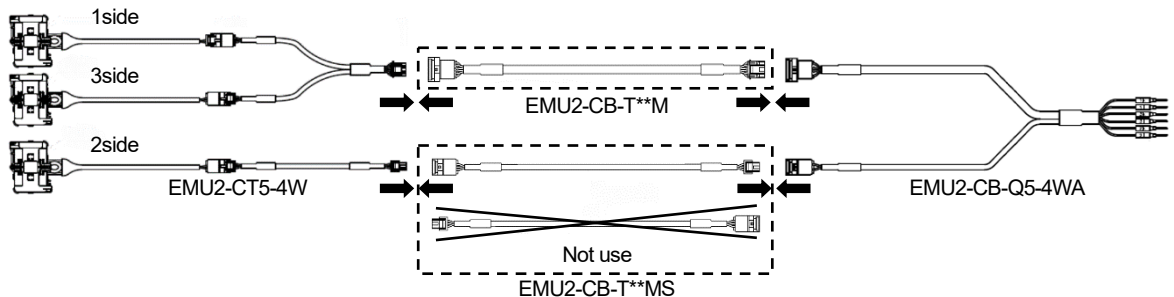

(3) If you want to extend a longer distance than the above (1) and (2), please extend the secondary side of current transformer (CT).

### 5.3.1 How to connect wire

<Voltage input terminals, External input/output terminals>

- Use appropriate crimp-type terminal. Applicable crimp-type terminal is shown in the tables below.
- Use electric wires as below, and tighten the terminal screws by the torque as below.

[EMU4-BM1-MB]

	Applicable wire	Tightening torque	Applicable crimp-type terminal
Power supply terminals, Voltage input terminals	Stranded wire: AWG22-16 (0.3 – 1.3mm <sup>2</sup> ) Single wire: AWG22-16 (0.65 - 1.25mm)	0.8 - 1.0 N·m	For M3.5 screw of external diameter below 7.1mm
MODBUS communication terminals	SPEV (SB) – MPC – 0.2×1P equivalent	0.5-0.6 N·m	For M3 screw of external diameter below 6.1mm

[EMU4-HM1-MB]

	Applicable wire	Tightening torque	Applicable crimp-type terminal
Power supply terminals, Voltage input terminals	Stranded wire: AWG22-16 (0.3 – 1.3mm <sup>2</sup> ) Single wire: AWG22-16 (0.3 – 1.25mm)	0.8 - 1.0N·m	For M3.5 screw of external diameter below 7.1mm
MODBUS communication terminals, External input/output terminals	SPEV(SB) – MPC – 0.2×1P equivalent	0.5-0.6 N·m	For M3 screw of external diameter below 6.1mm

<Current input terminals>

- Stripping length of the used wire in use has to be 10 to 11mm.
- In case using stranded wire, take measures so that the filament should not vary by using a bar terminal or by processing the point twisted.
- When attaching and detaching cables to/from the terminal, use the push button. Check that the wire is securely inserted.
- Insert a wire to the terminal all the way until it touches the end.
- Use appropriate electric wires as shown below.

Applicable wire	Applicable crimp-type terminal
stranded wire: AWG20-16 (0.5 - 1.3mm <sup>2</sup> ) single wire: AWG24-17 (0.5 - 1.2mm)	TGV TC-1.25-11T (by NICHIFU) equivalent

### 5.3.2 Connection of external input / external output

In case using external input and/or external output, refer to the following.

External input: For the case of contact input

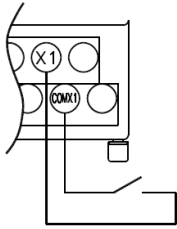

No-voltage a-contact / open collector  
Voltage of the contact is 5V DC, and current is 7mA, so use something appropriate for the switching condition.

External input: For the case of pulse input

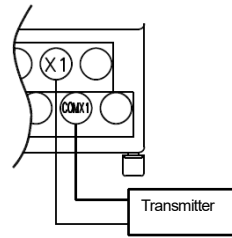

No-voltage a-contact / open collector  
Voltage of the contact is 5V DC, and current is 7mA, so use something appropriate for the switching condition.  
Please connect GND side to COM1 when output of transmitter is open collector pulse.

External output: For the case of contact output

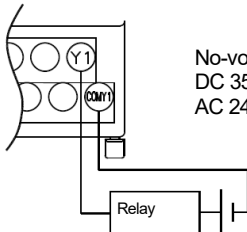

No-voltage a-contact  
DC 35V 75mA or,  
AC 24V 75mA (power factor : 1)

External output: For the case of pulse output

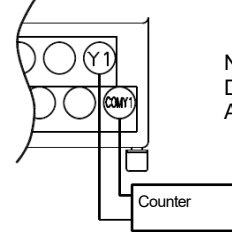

No-voltage a-contact  
DC 35V 75mA or,  
AC 24V 75mA (power factor : 1)

- Wiring length of external input (Reference value)  
The wire length for each wire diameter is below. Please refer to wiring.  
※Polyethylene insulating vinyl sheath cable FCPEV wire.

Wire diameter [mm]	Resistivity[Ω/km]	Wiring length[m]
0.5	94	300
0.65	56.8	400
0.9	29.2	750
1.2	16.5	1000

### 5.3.3 System configuration example of MODBUS communication

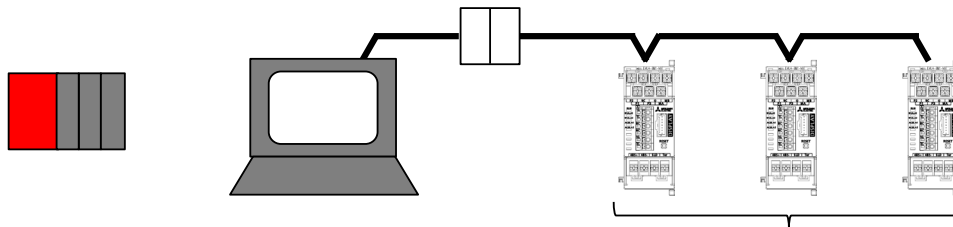

- Connection of MODBUS communication terminals:
  1. Use the twisted shielded pair cable for transmission lines. (Recommended cable 11.2)
  2. Connect the termination resistances (120Ω) to both ends of the devices connected the MODBUS transmission line.  
Termination resistances of 120Ω can be used by short-circuiting "485-" and "Ter" terminals.
  3. Connect to ground by using thick wires to decrease impedance.
  4. MODBUS transmission lines shall not be placed close to or bound together with the high-voltage lines.
  5. Ground the "SLD" terminal at one end.



Connection with MELSEC Q series MODBUS module (QJ71MB91, QJ71C24N)

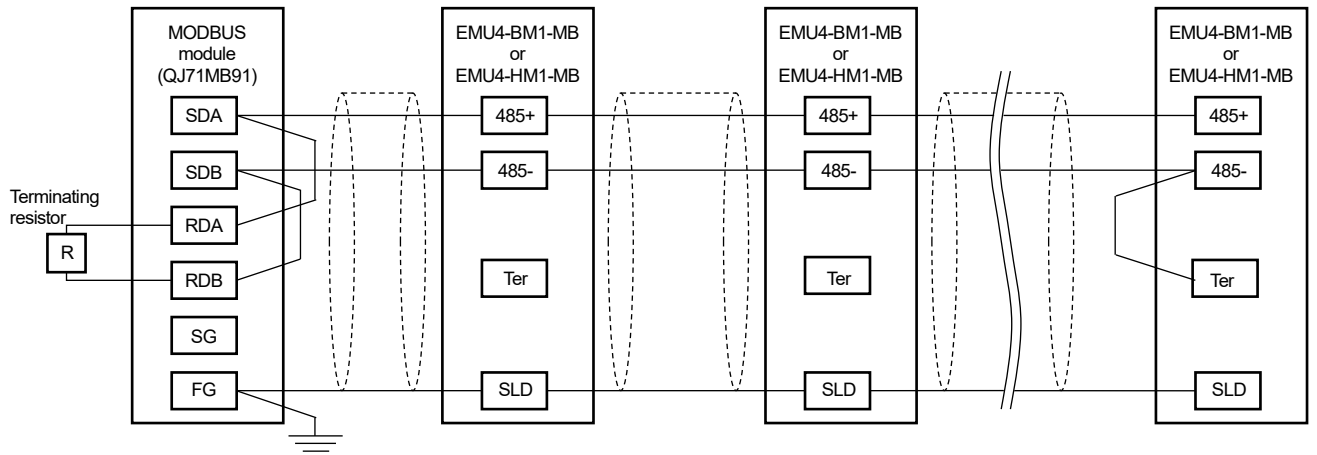

Note: Connect 110 ohm termination resistors on the MODBUS module (QJ71MB91, QJ71C24N) side.  
 For details, refer to [MODBUS Interface Module User's Manual] (Ref. No. SH-080578ENG) and [Q Corresponding Serial Communication Module User's Manual (Basic)] (Ref. No. SH-080006).

Connection with MELSEC iQ-F series programmable controller

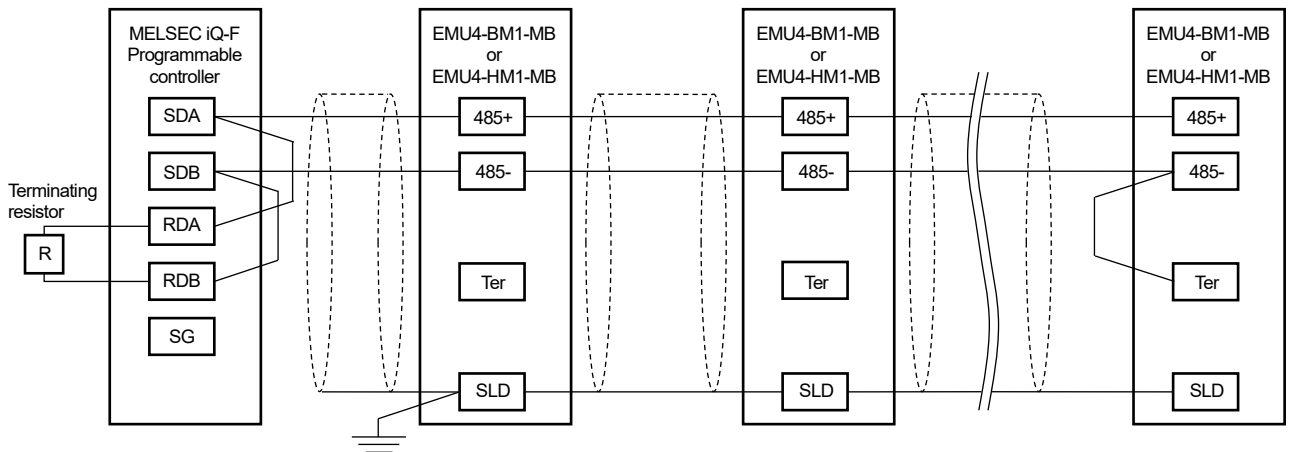

Note: Connect 110 ohm termination resistors on the MELSEC iQ-F programmable controller side.  
 For details, refer to [MELSEC iQ-F FX5 User's Manual (MODBUS Communication)] (Ref. No. JY997D56101).

Connection with MELSEC iQ-R Serial Communication Module (RJ71C24, RJ71C24-R4, RJ71C24-R4)

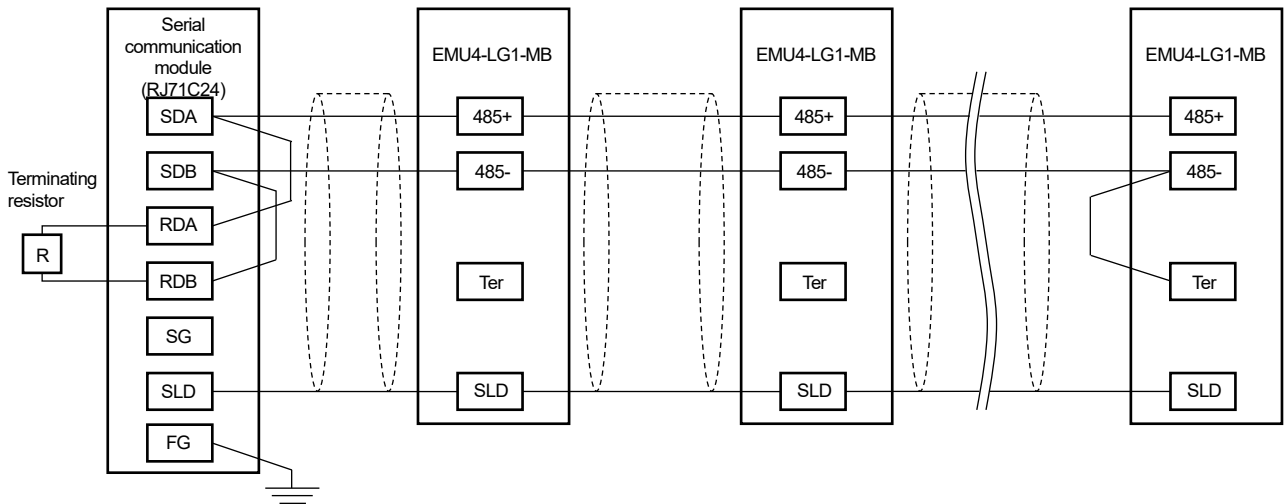

Note: Connect 110 ohm termination resistors on the MELSEC iQ-R programmable controller side.  
For details, refer to Before Using the Product for RJ71C24, RJ71C24-R4 and RJ71C24-R4 (Ref.NO. BCN-P5999-0075).

Connection with GOT (GOT1000, GOT2000)

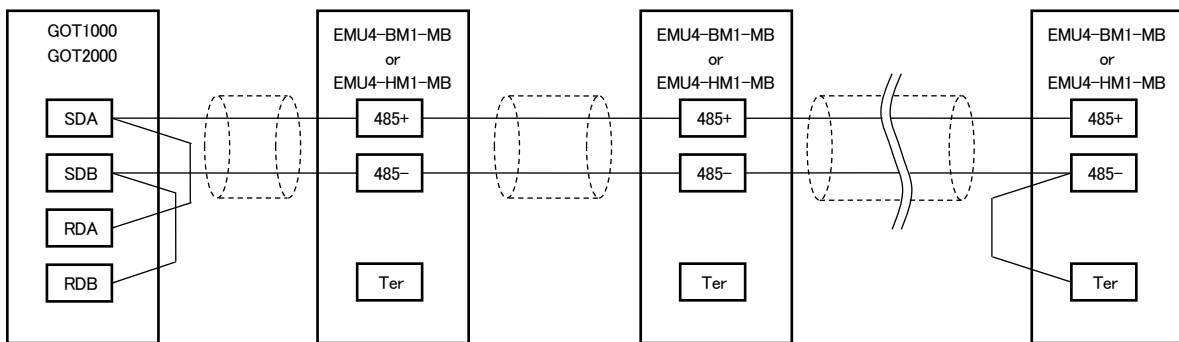

Note: Set the termination resistor of the GOT (GOT1000, GOT2000) side to 110 ohm.  
For details, refer to [GOT1000 Series Connection Manual (Microcomputers, MODBUS Products, Peripherals) for GT Works3] (Ref.NO. SH-080871ENG) and [GOT2000 Series Connection Manual (Microcomputers, MODBUS/Fieldbus Products, Peripherals) For GT Works3 Version1] (Ref.NO. SH-081200ENG).

## 6. Setting

### 6.1 Setting data

To set this unit, dedicated small-size display unit (EMU4-D65) is necessary.  
For the setting method, refer to User's manual (Details) of the display unit.

Items can be setup by model is showed below table.

Items	EMU4-BM1-MB	EMU4-HM1-MB
Phase wire system	○	○
2 circuits measuring setting	○	○
Primary voltage	○	○
Primary current	○	○
Demand time	○	○
Electric energy converted value	×	○
Cut-off rate of current	○	○
Simple measurement	○	○
External input	×	○
Operating time	○	○
External output	×	○
MODBUS Communication setting	○	○
Setup for logging	○ <sup>※1</sup>	○ <sup>※1</sup>
Setup for upper and lower limit alarm	○	○

\*: This items can be setup when using Logging Unit(EMU4-LM).

The data can be setup is showed below. Bold text is default setting value.

#### 6.1.1 Phase wire system

Setup is showed in below table in each unit.

Model	Setting value
EMU4-BM1-MB	1P2W, 1P3W, <b>3P3W</b>
EMU4-HM1-MB	1P2W, 1P3W, <b>3P3W</b> , 3P4W

#### 6.1.2 2 circuits measuring setting

Setup is showed in below table in phase wire system is 1P2W.

2 circuits measuring
<b>Use</b> , Non-use

#### 6.1.3 Primary voltage

Set the rated voltage of the measuring circuit. Please setup the primary voltage of VT when set "Use of VT".

Primary voltage is set below value by use of VT or not, setup for wiring type and unit.

Model	Phase wire system	Use or non-use of VT	Setting value
EMU4-BM1-MB	1P2W/3P3W	Non-use of VT	[Direct voltage]: 110V, <b>220V</b>
		Use of VT	[Primary voltage]: <b>440V</b> , 690V, 1100V, 2200V, 3300V, 6600V, 11000V, 13200V, 13800V, 15000V, 16500V, 22000V, 24000V, 33000V, 66000V, 77000V, 110000V, SP <sup>※</sup> <sup>※</sup> This setting value can be set [Special primary voltage] and [Special secondary voltage] when setting SP. Can be set in the 1V step. [Special primary voltage]: 1 to 110000V ( <b>440V</b> ) [Special secondary voltage]: 1 to 220V ( <b>110V</b> )
	1P3W	Non-use of VT (Hold)	[Direct voltage]: <b>110V</b>

Model	Phase wire system	Use or non-use of VT	Setting value
EMU4-HM1-MB	1P2W/3P3W	Non-use of VT	[Direct voltage]: 110V, <b>220V</b> , 440V
		Use of VT	[Primary voltage] : <b>440V</b> , 690V, 1100V, 2200V, 3300V, 6600V, 11000V, 13200V, 13800V, 15000V, 16500V, 22000V, 24000V, 33000V, 66000V, 77000V, 110000V, SP** ※This setting can set [Special primary voltage] and [Special secondary voltage] when setting SP. Can be set in the 1V step. [Special primary voltage]: 1 to 110000V ( <b>440V</b> ) [Special secondary voltage]: 1 to 220V ( <b>110V</b> )
	1P3W	Non-use of VT (Hold)	[Direct voltage]: <b>110V</b> , 220V
	3P4W	Non-use of VT	[Direct voltage]: 63.5V, 100V, 105V, 110V, 115V, 120V, 127V, 200V, <b>220V</b> , 230V, 240V, 242V, 250V, 254V, 265V, 277V
Use of VT		[Special primary voltage]: 1 to 63500V ( <b>440V</b> ) [Special secondary voltage]: 1 to 220V ( <b>64V</b> ) Can be set in the 1V step.	

### 6.1.4 Primary current

Set the rated current of the measuring circuit. Please select using sensor and setup primary current by sensor type.

Primary current is set below value by the sensor type. Value is common regardless of unit.

Sensor type	Setting value
Direct sensor (Use of EMU-CT***, EMU-CT***-A)	[Primary current]: 50A, <b>100A</b> , 250A, 400A, 600A
5A Sensor (Use of EMU2-CT5, EMU2-CT5-4W, EMU-CT5-A)	[Primary current]: 5A, 6A, 7.5A, 8A, 10A, 12A, 15A, 20A, 25A, 30A, 40A, 50A, 60A, 75A, 80A, <b>100A</b> , 120A, 150A, 200A, 250A, 300A, 400A, 500A, 600A, 750A, 800A, 1000A, 1200A, 1250A, 1500A, 1600A, 2000A, 2500A, 3000A, 4000A, 5000A, 6000A, 7500A, 8000A, 10000A, 12000A, 20000A, 25000A, 30000A, SP** ※Setup the [5A sensor special primary current] in SP setting. 10A less than, the upper two digits. 10A or more is possible to set the upper three digits. [5A sensor special primary current]: 5.0 to 30000A ( <b>100A</b> )

#### ⚠ Caution

● EMU-CT\*\*\* and EMU-CT\*\*\*-A are used only for low voltage circuit. It cannot be used for a high voltage circuit. EMU2-CT5 and EMU2-CT5-4W should be used with the secondary side (5A) of transformer transfixed. If they are used for the circuit directly, they should be used under 200V.  
 If it is connected with a high-voltage circuit by mistake, it may cause a burnout of the device and a fire. It is critically dangerous

#### ✓ Supplement

- Please setup CT rating of primary side when use EMU2-CT5, EMU2-CT5-4W or EMU-CT5-A.
- Full load power is calculated in below equation.

$$\text{Full load power [kW]} = \frac{\alpha \times (\text{VT primary voltage}) \times (\text{CT primary current})}{1000}$$

α : 1	Single-phase, 2-wire
2	Single-phase, 3-wire
√3	Three-phase, 3-wire
3	Three-phase, 4-wire

\*1: VT primary voltage in single-phase 3-wire system is regarded as 110V.

\*2: Using direct connection, replace VT primary voltage with direct voltage in calculation above.

\*3: In three-phase 4-wire system, replace VT primary voltage or direct voltage with phase voltage in calculation above.

### 6.1.5 Demand time

Current demand alarm, electric energy can be setup in each. It is common regardless the unit type.

Setting item	Setting value
Current demand time	0sec, 10 sec, 20 sec, 30 sec, 40 sec, 50 sec, 1min, <b>2 min</b> , 3 min, 4min, 5 min, 6 min, 7 min, 8 min, 9 min, 10 min, 11 min, 12 min, 13 min, 14 min, 15 min, 20 min, 25 min, 30 min
Power demand time	0sec, 10 sec, 20 sec, 30 sec, 40 sec, 50 sec, 1min, <b>2 min</b> , 3 min, 4min, 5 min, 6 min, 7 min, 8 min, 9 min, 10 min, 11 min, 12 min, 13 min, 14 min, 15 min, 20 min, 25 min, 30 min

### 6.1.6 Electric energy converted value

Setup the converted rate and conversion unit of electric converted value.

You can't setup in EMU4-BM1-MB. Please setup electric energy conversion rate 1side and 3side in 2 circuits measuring in 1P2W.

Electric energy converted value = Electric energy × Wh conversion rate

Setting item	Setting value
Wh conversion rate	0.001 to 10000 ( <b>1.000</b> )
Unit	<b>Off</b> , Wh, kWh, MWh, J, m <sup>2</sup> , m <sup>3</sup> , L, kL, sec, min, hour, piece, unit, g, kg, t, ¥, \$

### 6.1.7 Cut-off rate of current\*

Set the cut-off value when measuring current. Measured current is 0 when measured current is lower than Cut-off current.

Cut-off current = Rated current × Cut-off rate.

Setup is common regardless of unit type. Please setup cut-off rate of current rate 1side and 3side in 2 circuits measuring.

※The ratio of measured lower current limit (cut-off current) to primary current.

Primary current × cut-off rate = cut-off current

Setting item	Setting value
Cut-off current	0.1 to 50.0% ( <b>0.5</b> )

### 6.1.8 Simple measurement

Setup the whether to do simple measurement.

Setup is common regardless of unit type. Please setup power factor 1side and 3side in 2 circuits measuring.

Please reference to  for simple measurement

Setting item	Setting value
Simple measurement	<b>OFF</b> , ON
Setup for power factor	-0.001 ~ <b>1.000</b> ~ 0.000

### 6.1.9 External input

Setup the measurement target of external input. You can't setup in EMU4-BM1-MB.

External input	Setting item	Setting value
	External input	<b>Non</b> , contact, pulse
Contact input	Reset method	Auto, Hold
Pulse input	Pulse converted	0.001 to 10000 ( <b>1.000</b> )
	Unit	<b>Off</b> , Wh, kWh, MWh, J, m <sup>2</sup> , m <sup>3</sup> , L, kL, sec, min, hour, piece, unit, g, kg, t, ¥, \$

### 6.1.10 Operating time

Setup the whether to measure operating time. Setting value is showed below table.

Please setup operating time 1side and 3side in 2 circuits measuring in 1P2W.

Operating time is integration time while current measuring when select Current. Operating time is integration time while Contact input is ON when Contact input.

Model	Setting items	Setting value
EMU4-BM1-MB	Counting operating time	<b>OFF</b> , ON
	Counting method of operating time	<b>Current input</b>
EMU4-HM1-MB	Counting operating time	<b>OFF</b> , ON
	Counting method of operating time	<b>Current input, Contact input</b>

### 6.1.11 External output

Setup the output method of the contact output terminal. Please setup external output in which circuit 1 side circuit or 3 side circuit. You can't setup in EMU4-BM1-MB.

External output method	Setting item	Setting value																					
Pulse output	The unit of pulse output	Setting range is changed by the value of Full load power.																					
		<table border="1"> <thead> <tr> <th colspan="2">Total load power(kW)</th> <th>Setting range</th> </tr> </thead> <tbody> <tr> <td>Less than 12</td> <td></td> <td><b>0.001</b>, 0.01, 0.1, 1</td> </tr> <tr> <td>12 or more</td> <td>Less than 120</td> <td><b>0.01</b>, 0.1, 1, 10</td> </tr> <tr> <td>120 or more</td> <td>Less than 1200</td> <td><b>0.1</b>, 1, 10, 100</td> </tr> <tr> <td>1200 or more</td> <td>Less than 12000</td> <td><b>1</b>, 10, 100, 1000</td> </tr> <tr> <td>12000 or more</td> <td>Less than 120000</td> <td><b>10</b>, 100, 1000, 10000</td> </tr> <tr> <td>120000 or more</td> <td></td> <td><b>100</b>, 1000, 10000, 100000</td> </tr> </tbody> </table>	Total load power(kW)		Setting range	Less than 12		<b>0.001</b> , 0.01, 0.1, 1	12 or more	Less than 120	<b>0.01</b> , 0.1, 1, 10	120 or more	Less than 1200	<b>0.1</b> , 1, 10, 100	1200 or more	Less than 12000	<b>1</b> , 10, 100, 1000	12000 or more	Less than 120000	<b>10</b> , 100, 1000, 10000	120000 or more		<b>100</b> , 1000, 10000, 100000
		Total load power(kW)		Setting range																			
		Less than 12		<b>0.001</b> , 0.01, 0.1, 1																			
		12 or more	Less than 120	<b>0.01</b> , 0.1, 1, 10																			
		120 or more	Less than 1200	<b>0.1</b> , 1, 10, 100																			
		1200 or more	Less than 12000	<b>1</b> , 10, 100, 1000																			
12000 or more	Less than 120000	<b>10</b> , 100, 1000, 10000																					
120000 or more		<b>100</b> , 1000, 10000, 100000																					
Alarm output	The object of alarm output	<b>1</b> , 2 *If the target of external output is 1K, 1L connection side circuit, Set [1]. If the target of external output is 3K, 3L connection side circuit, Set [2].																					

### 6.1.12 MODBUS Communication setting

Setup the items for MODBUS communication. Setting values are showed below. This is common regardless of units.

Setting item	Setting value
MODBUS Address	<b>001</b> to 255
MODBUS Baud rate	2400, 4800, 9600, <b>19200</b> , 38400
MODBUS Parity	Non, <b>Even</b> , Odd
MODBUS Sop bit	<b>1</b> , 2

### 6.1.13 Setup for logging

Setup the items for logging using EMU4-LM. Setting values are showed below. This is common regardless of units.

Setting item	Setting value
Logging ID	<b>001</b> ~255
Confirmation of logging data	<b>OK</b> , Cancel

### 6.1.14 Setup for upper and lower limit alarm

Setup the whether to monitor upper and lower limit alarm.

Please refer to 7.2.2 Upper/lower limit monitoring function for more details.

Showned below table. Please setup upper and lower limit alarm of second circuit (3 side circuit) in 2 circuits measuring in 1P2W.

Setting item		Setting values
Upper and lower limit alarm existence		<b>ON</b> , OFF
Elements of upper and lower limit alarm		Current demand upper limit, current demand lower limit, line voltage upper limit, line voltage lower limit, phase voltage upper limit, phase voltage lower limit, electric power upper limit, electric power lower limit, power factor upper limit, power factor lower limit, N phase demand current upper limit, N phase demand current lower limit, pulse converted upper limit, pulse converted lower limit, current unbalance rate upper limit, current unbalance rate lower limit
Upper and lower limit	Current demand upper limit N phase current demand upper limit	0~120% of primary current ( <b>100% of primary current</b> ) The minimum step of settable value is varies by primary current. Less than 40A : Step 0.01A 40A ~ 400A : Step 0.1A 400A ~ 4000A : Step 1A 4000A ~ : Step 10A
	Current demand lower limit	0~120% of primary current ( <b>0% of primary current</b> ) The minimum step of settable value is varies by primary current. Lower than 40A : Step 0.01A 40A ~ 400A : Step 0.1A 400A ~ 4000A : Step 1A 4000A ~ : Step 10A
	Line voltage upper limit Phase voltage upper limit	0~100%×15/11 of primary voltage ( <b>110% of primary voltage</b> ) The minimum step of settable value is varies by primary voltage. Less than 300V : Step 0.1V 300V ~ 3000V : Step 1V 3000V ~ : Step 10V
	Line voltage lower limit Phase voltage lower limit	0~100%×15/11 of primary voltage ( <b>0% of primary voltage</b> ) The minimum step of settable value is varies by primary voltage. Less than 300V : Step 0.1V 300V ~ 3000V : Step 1V 3000V ~ : Step 10V
	Electric power upper limit	-120~0~120% of full load ( <b>100% of full load</b> ) The minimum step of settable value is varies by full load. Less than 12kW : Step 0.001kW 12kW ~ 120kW : Step 0.01kW 120kW ~ 1200kW : Step 0.1kW 1200kW ~ 12000kW : Step 1kW 12000kW ~ 120000kW : Step 10kW 120000kW ~ : Step 100kW
	Electric power lower limit	-120~0~120% of full load ( <b>0% of full load</b> ) The minimum step of settable value is varies by full load. Less than 12kW : Step 0.001kW 12kW ~ 120kW : Step 0.01kW 120kW ~ 1200kW : Step 0.1kW 1200kW ~ 12000kW : Step 1kW 12000kW ~ 120000kW : Step 10kW 120000kW ~ : Step 100kW
	Power factor upper limit	-0.050, -0.100, ...-0.950, 1.000, 0.950, ...0.100, 0.050 ( <b>-0.500</b> )
	Power factor lower limit	-0.050, -0.100, ...-0.950, 1.000, 0.950, ...0.100, 0.050 ( <b>0.500</b> )
	Pulse converted upper limit	1 to 999999 ( <b>100000</b> )
	Current unbalance rate upper limit	0.01 to 999.99% ( <b>30.00%</b> )
Voltage unbalance rate upper limit	0.01 to 999.99% ( <b>3.00%</b> )	
Alarm delay time		<b>0sec</b> , 5sec, 10sec, 20sec, 30sec, 40sec, 50sec, 1min, 2min, 3min, 4min, 5min
Alarm reset method		<b>Auto</b> , Hold







## 7. Operation

### 7.1 Measurement

Measurement elements are showed below table in each unit.

In the case displaying in Display unit.

Displayed items		EMU4-BM1-MB			EMU4-HM1-MB					
		Wh+A+4 items			Wh+A+4 items			Harmonics		
		1P2W		1P3W /3P3W	1P2W		1P3W /3P3W /3P4W	1P2W		1P3W /3P3W /3P4W
		1 circuit measuring	2 circuits measuring		1 circuit measuring	2 circuits measuring		1 circuit measuring	2 circuits measuring	
Electric energy	Present	●	●	●	●	●	●	●	●	●
Electric energy (converted)	Present	—	—	—	○	○	○	●	●	●
Periodic electric energy	Present	—	—	—	○	○	○	●	●	●
Operating time	Present	○	○	○	○	○	○	●	●	●
Electric energy( regenerated)	Present	○	○	○	○	○	○	●	●	●
Pulse count	Present	—	—	—	○	○	○	●	●	●
Pulse converted	Present	—	—	—	○	○	○	●	●	●
Current	1,2,3,N,Total <sup>※1</sup>	●	●	●	●	●	●	●	●	●
Demand current	1,2,3,N <sup>※1</sup>	●	●	●	●	●	●	●	●	●
	Max, Min	—	—	—	—	—	—	—	—	—
Voltage	1-2,2-3,3-1,1-N, 2-N,3-N, Total <sup>※2</sup>	○	○	○	○	○	○	●	●	●
	Max, Min	—	—	—	—	—	—	—	—	—
Electric power	Present	○	○	○	○	○	○	●	●	●
Demand electric power	Present	○	○	○	○	○	○	●	●	●
	Max, Min	—	—	—	—	—	—	—	—	—
Reactive power	Present	○	○	○	○	○	○	●	●	●
Apparent power	Present	—	—	—	—	—	○ <sup>※7</sup>	—	—	—
Power factor	Present	○	○	○	○	○	○	●	●	●
	Max, Min	—	—	—	—	—	—	—	—	—
Frequency	Present	○	○	○	○	○	○	●	●	●
Harmonics current RMS/distortion	1,2,3,N <sup>※3</sup>	—	—	—	○	○	○	○ <sup>※5</sup>	○ <sup>※5</sup>	○ <sup>※5</sup>
Harmonics voltage RMS /distortion	1-2,2-3, 1-N,2-N,3-N <sup>※4</sup>	—	—	—	○	○	○	○ <sup>※5</sup>	○ <sup>※5</sup>	○ <sup>※5</sup>
1-13N harmonics current <sup>※9</sup> RMS /content rate	1,2,3,N <sup>※3</sup>	—	—	—	—	—	—	○ <sup>※5</sup>	○ <sup>※5</sup>	○ <sup>※5</sup>
1-13N harmonics voltage <sup>※9</sup> RMS /content rate	1-2,2-3, 1-N,2-N,3-N <sup>※4</sup>	—	—	—	—	—	—	○ <sup>※5</sup>	○ <sup>※5</sup>	○ <sup>※5</sup>
Reactive energy	Present	○	—	○	○	—	○	—	—	—
Current unbalance rate	Present	○ <sup>※6</sup>	○ <sup>※6</sup>	○	○ <sup>※6</sup>	○ <sup>※6</sup>	○	—	—	○
	Max	—	—	—	—	—	—	—	—	—
Voltage unbalance rate	Present	○ <sup>※6</sup>	○ <sup>※6</sup>	○	○ <sup>※6</sup>	○ <sup>※6</sup>	○	—	—	○
	Max	—	—	—	—	—	—	—	—	—
Time	Present	● <sup>※8</sup>	● <sup>※8</sup>	● <sup>※8</sup>	● <sup>※8</sup>	● <sup>※8</sup>	● <sup>※8</sup>	● <sup>※8</sup>	● <sup>※8</sup>	● <sup>※8</sup>
Error	—	●	●	●	●	●	●	●	●	●

● ... Measured data

○ ... Only displayed when selected additional items

— ... Not measured data

※1 2 and 3 phases is not displayed in wiring setting 1P2W. N phase is only displayed in 3P4W setting.

※2 Between 2 and 3, 3 and 1 is not displayed in setting 1P2W1-N. Between 2 and N, 3 and N is displayed in 3P4W setting.

※3 If wiring setting is 1P2W, 3 phase is not displayed. 2 phase is only displayed in setting 3P4W.

※4 If wiring setting is 1P2W, between 2 and 3 is not displayed. Between 1 and N, 2 and N, 3 and N is only displayed.

※5 Either effective value and content rate ,distortion by the setting elements of HA and HV.

※6 Current unbalance rate, voltage unbalance rate is displayed 0% in 1P2W setting.

※7 Apparent power is only measured in 3P4W setting

※8 Present time is only displayed when connected EMU4-LM.

※9 3rd, 5th, 7th, 9th, 11th, 13th are displayed.

In the case monitoring with various communications

The supported communications are as follows.

- CC-Link communication
- CC-Link IE Field Basic communication
- SLMP communication
- MODBUS communication

Monitored items		EMU4-BM1-MB			EMU4-HM1-MB		
		1P2W		1P3W /3P3W	1P2W		1P3W /3P3W /3P4W
		1 circuit measuring	2 circuits measuring		1 circuit measuring	2 circuits measuring	
Electric energy	Present	●	●	●	●	●	●
Electric energy (expansion)	Present	●	●	●	●	●	●
Electric energy (converted)	Present	—	—	—	●	●	●
Periodic electric energy	Present	—	—	—	●	●	●
Operating time	Present	●	●	●	●	●	●
Electric energy (regenerated) (expansion)	Present	●	●	●	●	●	●
Electric energy (regenerated)	Present	●	●	●	●	●	●
Pulse count	Present	—	—	—	●	●	●
Pulse converted	Present	—	—	—	●	●	●
Current	1,2,3,N,Total	●	●	●	●	●	●
Demand current	1,2,3,N	●	●	●	●	●	●
	Max,Min <sup>※3</sup>	△	△	△	△	△	△
Voltage	1-2,2-3,3-1,1-N, 2-N,3-N,Total	●	●	●	●	●	●
	Max,Min <sup>※3</sup>	△	△	△	△	△	△
	Present	●	●	●	●	●	●
Electric power	Present	●	●	●	●	●	●
Demand electric power	Present	●	●	●	●	●	●
	Max,Min <sup>※3</sup>	△	△	△	△	△	△
Reactive power	Present	●	●	●	●	●	●
Apparent power <sup>※1</sup>	Present	—	—	—	—	—	● <sup>※1</sup>
Power factor	Present	●	●	●	●	●	●
	Max,Min <sup>※3</sup>	△	△	△	△	△	△
Frequency	Present	●	●	●	●	●	●
Harmonics current RMS value/distortion	1,2,3,N	—	—	—	●	●	●
Harmonics voltage RMS value/distortion	1-2,2-3,3-1, 1-N,2-N,3-N	—	—	—	●	●	●
1-13N harmonics current RMS value /content rate	1,2,3,N	—	—	—	●	●	●
1-13N harmonics voltage RMS value /content rate	1-2,2-3, 1-N,2-N,3-N	—	—	—	●	●	●
Reactive energy	Present	●	●	●	●	●	●
Reactive energy (expansion)	Present	●	●	●	●	●	●
Current unbalance rate <sup>※2</sup>	Present	—	—	△	—	—	△
	Max <sup>※3</sup>	△	△	△	△	△	△
Voltage unbalance rate <sup>※2</sup>	Present	—	—	△	—	—	△
	Max <sup>※3</sup>	△	△	△	△	△	△
Time	Present	—	—	—	—	—	—
Error	—	●	●	●	●	●	●

- ... Monitorable data
- △ ... Monitorable data by somecommunication
- ... Not monitorable data

※1 Apparent power is only measured in 3P4W setting.

※2 Moniotrable only by in 3P4W setting.

※3 Apparent power is only measured in 3P4W setting.

In the case logging using EMU4-LM

Monitored items			Model							
			EMU4-BM1-MB			EMU4-HM1-MB				
			1P2W	1P3W	3P3W	1P2W	1P3W	3P3W	3P4W	
Current	Total		●	●	●	●	●	●	●	
	1 phase		●	●	●	●	●	●	●	
	2 phase		—	●	●	—	●	●	●	
	3 phase		● <sup>*1</sup>	●	●	● <sup>*1</sup>	●	●	●	
	N phase		—	—	—	—	—	—	●	
Demand current	1 phase		●	●	●	●	●	●	●	
	2 phase		—	●	●	—	●	●	●	
	3 phase		● <sup>*1</sup>	●	●	● <sup>*1</sup>	●	●	●	
	N phase		—	—	—	—	—	—	●	
Voltage	1-N phase		—	—	—	—	—	—	●	
	2-N phase		—	—	—	—	—	—	●	
	3-N phase		—	—	—	—	—	—	●	
	Total (line)		●	●	●	●	●	●	●	
	1-2 line		●	●	●	●	●	●	●	
	2-3 line		● <sup>*1</sup>	●	●	● <sup>*1</sup>	●	●	●	
	3-1 line		—	●	●	—	●	●	●	
				—	—	—	—	—	●	
Electric power	[1] <sup>*2</sup>		●	●	●	●	●	●	●	
	[2] <sup>*2</sup>		●	—	—	●	—	—	—	
Demand electric power	[1] <sup>*2</sup>		●	●	●	●	●	●	●	
	[2] <sup>*2</sup>		●	—	—	●	—	—	—	
Reactive power	[1] <sup>*2</sup>		●	●	●	●	●	●	●	
	[2] <sup>*2</sup>		●	—	—	●	—	—	—	
Apparent power			—	—	—	—	—	—	●	
Power factor	[1] <sup>*2</sup>		●	●	●	●	●	●	●	
	[2] <sup>*2</sup>		●	—	—	●	—	—	—	
Frequency			●	●	●	●	●	●	●	
Current unbalance rate			—	●	●	—	●	●	●	
Voltage unbalance rate			—	●	●	—	●	●	●	
Harmonic current	RMS value	Total Fundamental 3~13 <sup>th</sup>	1 phase	—	—	—	●	●	●	●
			2 phase	—	—	—	—	—	—	●
			3 phase	—	—	—	● <sup>*1</sup>	●	●	●
			N phase	—	—	—	—	—	—	●
	distortion (content rate)	Total 3~13 <sup>th</sup>	1 phase	—	—	—	●	●	●	●
			2 phase	—	—	—	—	—	—	●
			3 phase	—	—	—	● <sup>*1</sup>	●	●	●
			N phase	—	—	—	—	—	—	●
Harmonic voltage	RMS value	Total Fundamental 3~13 <sup>th</sup>	1-N phase	—	—	—	●	●	●	●
			2-N phase	—	—	—	—	—	—	●
			3-N phase	—	—	—	● <sup>*1</sup>	●	●	●
			N phase	—	—	—	—	—	—	●
			1-2 line	—	—	—	●	●	●	—
			2-3 line	—	—	—	● <sup>*1</sup>	●	●	—
	distortion (content rate)	Total 3~13 <sup>th</sup>	1-N phase	—	—	—	—	—	—	●
			2-N phase	—	—	—	—	—	—	●
			3-N phase	—	—	—	—	—	—	●
			1-2 line	—	—	—	●	●	●	—
2-3 line	—	—	—	● <sup>*1</sup>	●	●	—			
Electric energy	Consumption	[1] <sup>*2</sup>	●	●	●	●	●	●	●	
		[2] <sup>*2</sup>	●	—	—	●	—	—	—	
	Regenerated	[1] <sup>*2</sup>	●	●	●	●	●	●	●	
		[2] <sup>*2</sup>	●	—	—	●	—	—	—	
	Consumption (expansion)		—	—	—	—	—	—	—	
	Regenerated (expansion)		—	—	—	—	—	—	—	
Reactive energy	LAG		●	●	●	●	●	●	●	
	LEAD		—	—	—	—	—	—	—	
Electric energy (converted)			—	—	—	—	—	—	—	
Operating time			—	—	—	—	—	—	—	
Periodic electric energy			—	—	—	●	●	●	●	
Pulse count			—	—	—	●	●	●	●	
Pulse converted			—	—	—	●	●	●	●	

● ... Loggable data  
 — ... Not loggable data

\*1: Shows second circuit (3 side circuit) when setting 2 circuits measuring in 1P2W.

\*2: [1] shows first circuit when setting 2 circuits measuring in 1P2W. It is displayed when not setting 2 circuits measuring or 1P3W, 3P3W, 3P4W.[2] shows second circuit (3 side) when setting 2 circuits measuring in 1P2W.

The details of measurement items showed below table.

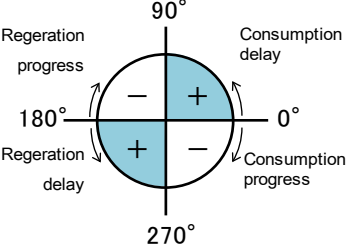
Item	Details										
Electric power Reactive power Power factor	The sign of measured value is showed below figure. 										
RMS current value (Average)	Calculated depending on the phase-wire system. <table border="1" data-bbox="646 495 1497 656"> <thead> <tr> <th>Phase-wire system</th> <th>Calculating formula</th> </tr> </thead> <tbody> <tr> <td>Single-phase 2-wire</td> <td>phase 1 current</td> </tr> <tr> <td>Single-phase 3-wire</td> <td>(phase 1 current + phase 3 current) / 2</td> </tr> <tr> <td>Three-phase 3-wire</td> <td>(phase 1 current + phase 2 current + phase 3 current) / 3</td> </tr> <tr> <td>Three-phase 4-wire</td> <td>(phase 1 current + phase 2 current + phase 3 current) / 3</td> </tr> </tbody> </table>	Phase-wire system	Calculating formula	Single-phase 2-wire	phase 1 current	Single-phase 3-wire	(phase 1 current + phase 3 current) / 2	Three-phase 3-wire	(phase 1 current + phase 2 current + phase 3 current) / 3	Three-phase 4-wire	(phase 1 current + phase 2 current + phase 3 current) / 3
Phase-wire system	Calculating formula										
Single-phase 2-wire	phase 1 current										
Single-phase 3-wire	(phase 1 current + phase 3 current) / 2										
Three-phase 3-wire	(phase 1 current + phase 2 current + phase 3 current) / 3										
Three-phase 4-wire	(phase 1 current + phase 2 current + phase 3 current) / 3										
RMS voltage value (Average)	Calculated depending on the phase-wire system. <table border="1" data-bbox="646 689 1410 851"> <thead> <tr> <th>Phase-wire system</th> <th>Calculating formula</th> </tr> </thead> <tbody> <tr> <td>Single-phase 2-wire</td> <td>voltage V12</td> </tr> <tr> <td>Single-phase 3-wire</td> <td>(voltage V12+ voltageV23) / 2</td> </tr> <tr> <td>Three-phase 3-wire</td> <td>(voltage V12 + voltage V23+ voltage V31) / 3</td> </tr> <tr> <td>Three-phase 4-wire</td> <td>(voltage V12 + voltage V23+ voltage V31) / 3</td> </tr> </tbody> </table>	Phase-wire system	Calculating formula	Single-phase 2-wire	voltage V12	Single-phase 3-wire	(voltage V12+ voltageV23) / 2	Three-phase 3-wire	(voltage V12 + voltage V23+ voltage V31) / 3	Three-phase 4-wire	(voltage V12 + voltage V23+ voltage V31) / 3
Phase-wire system	Calculating formula										
Single-phase 2-wire	voltage V12										
Single-phase 3-wire	(voltage V12+ voltageV23) / 2										
Three-phase 3-wire	(voltage V12 + voltage V23+ voltage V31) / 3										
Three-phase 4-wire	(voltage V12 + voltage V23+ voltage V31) / 3										
Electric energy conversion	Calculated below equation. Electric energy×Electric energy converted value ※Electric energy converted value : 0.000~10000 (Initial value : 1.000)										
Operating time	Measuring the time during contact input is ON or measuring current. <table border="1" data-bbox="646 976 1050 1048"> <thead> <tr> <th>Measurement range</th> <th>Unit</th> </tr> </thead> <tbody> <tr> <td>0~999999</td> <td>Time [hour]</td> </tr> </tbody> </table>	Measurement range	Unit	0~999999	Time [hour]						
Measurement range	Unit										
0~999999	Time [hour]										
Periodic electric energy	Measuring the electric energy (consumption) during contact input is ON.										
Pulse count	Measure the input pulse. Measure the output pulse of equipment by connecting it. <table border="1" data-bbox="646 1153 987 1225"> <thead> <tr> <th>Measurement range</th> <th>Unit</th> </tr> </thead> <tbody> <tr> <td>0~999999</td> <td>Pulse</td> </tr> </tbody> </table>	Measurement range	Unit	0~999999	Pulse						
Measurement range	Unit										
0~999999	Pulse										
Pulse conversion	Calculated below equation. Pulse count ×Pulse converted value ※Pulse converted value : 0.000~10000 (Initial value : 1.000)										

## 7.2 Upper/lower limit monitoring function

### 7.2.1 About monitoring elements

Monitoring elements in each unit are showed in below table.

● ... Can monitor data      — ... Can't monitoring data

Monitoring items	Display or not in each unit	
	EMU4-BM1-MB	EMU4-HM1-MB
Current demand upper limit alarm	●	●
Current demand lower limit alarm	●	●
Line voltage upper limit alarm	●	●
Line voltage lower limit alarm	●	●
Phase voltage upper limit alarm	—	●※1
Phase voltage lower limit alarm	—	●※1
Electric energy demand upper limit alarm	●	●
Electric energy demand lower limit alarm	●	●
Power factor upper limit alarm	●	●
Power factor lower limit alarm	●	●
Phase N current demand upper limit alarm	—	●※1
Pulse conversion upper limit alarm	—	●
Current unbalance rate upper limit alarm	●	●
Voltage unbalance rate upper limit alarm	●	●

※1 Can only monitor only when wiring type is 3P4W.



### 7.2.2 How to use upper/lower limit alarm function

This device can set the upper/lower limit alarm value for each measured value individually.

< Monitoring items >

Upper limit alarm items	Current demand, Line voltage, Phase voltage, Electric power demand, Power factor, N phase current demand, Pulse converted, Current unbalance rate, Voltage unbalance rate
Lower limit alarm items	Current demand, Line voltage, Phase voltage, Electric power demand, Power factor,

< Alarm setting >

- Upper limit value      Set the upper limit of measured value. For setting value and setting range,  6.1.12 Upper and lower alarm setting
- Lower limit value      Set the lower limit of measured value. For setting value and setting range,  6.1.12 Upper and lower alarm setting
- Alarm delay time      Set the value in case you want to remove the inrush current of the load, etc. from the objects of monitoring. Alarm does not occur when the measured value goes below the upper limit or goes over the lower limit within the configured time. For setting value and setting range,  6.1.12 Upper and lower alarm setting
- Alarm reset method      Alarm recovery operation is different according to the alarm reset method.

Reset method	Alarm recovery operation
Auto-reset (Auto)	Reset the alarm automatically if the measured value goes below the upper limit or goes over the lower limit.
Self-retention (Hold)	The alarm is held after the measured value goes below the upper limit or goes over the lower limit. Alarm is cleared by alarm reset.

For setting alarm reset operation  6.1.12 Upper and lower alarm setting. Please reference to display unit instruction manual (detail).

< Alarm occurrence / recovery condition >

Alarm item	Alarm reset method	Alarm status	Alarm occurrence / recovery condition	
Current demand Line voltage Phase voltage Electric power demand Power factor Phase N current demand Current unbalance rate Voltage unbalance rate	Auto-reset (Auto)	Upper limit alarm	Occurrence	Measured value > configured upper limit (Alarm delay time is available)
			Recovery	Measured value < configured upper limit
		Lower limit alarm	Occurrence	Measured value < configured lower limit (Alarm delay time is available)
			Recovery	Measured value > configured lower limit
	Self-retention (Hold)	Upper limit monitoring	Occurrence	Measured value > configured upper limit (Alarm delay time is available)
			Retention	Measured value $\leq$ configured upper limit
			Recovery	Measured value < configured upper limit AND Alarm reset
		Lower limit monitoring	Occurrence	Measured value < configured lower limit (Alarm delay time is available)
Retention	Measured value $\geq$ configured lower limit			
Recovery	Measured value > configured lower limit AND Alarm reset			
Pulse conversion	Auto-reset (Auto)	Upper limit monitoring	Occurrence	Measured value $\geq$ configured upper limit
			Recovery	Measured value < configured upper limit
	Self-retention (Hold)	Lower limit monitoring	Occurrence	Measured value $\geq$ configured upper limit
			Recovery	Measured value < configured upper limit

Caution: Since the measured value of pulse count value is an integrated value, it does not decrease.

When an alarm occurs, it is necessary to satisfy the recovery condition by one of the following methods.

- Reset Pulse count
- Preset Pulse count less than setting value of upper limit alarm
- Setup upper limit alarm more than pulse count

(1) Upper limit alarm

Alarm reset method = Auto

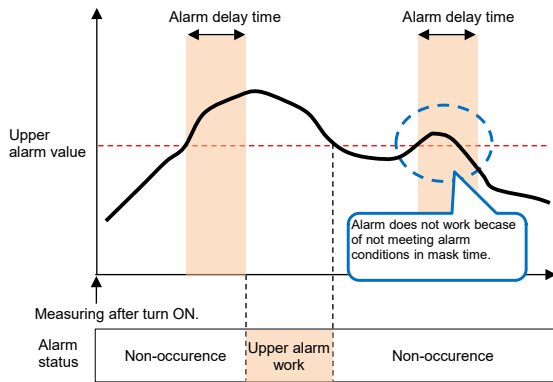

Alarm reset method = Hold

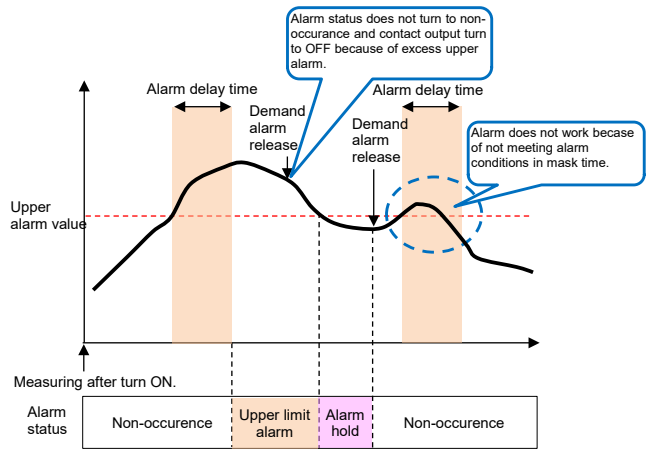

(2) Lower limit alarm

Alarm reset method = Auto

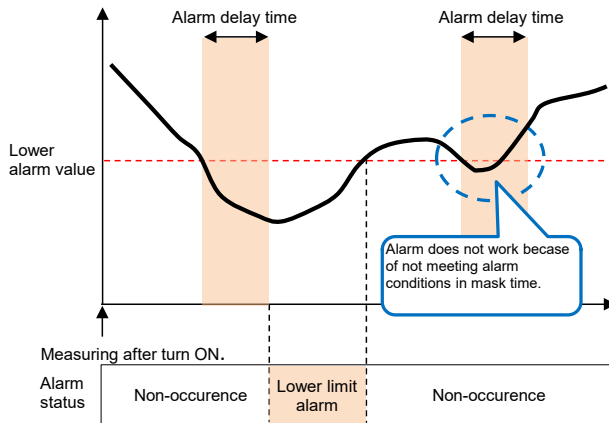

Alarm reset method = Hold

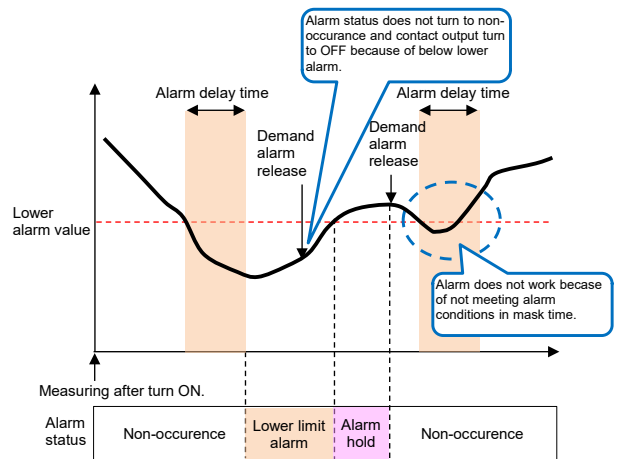



## 7.3 Simple measurement

This unit is equipped monitoring function without input voltage.  
Each measurement elements calculated by the voltage and power factor and input current.  
Measurement resolution is not guarantee.

### 7.3.1 Measurement elements

The elements can measure are showed below table.  
In the case displaying in Display unit.

		EMU4-BM1-MB			EMU4-HM1-MB					
		Wh+A+4 elements			Wh+A+4 elements			Harmonics		
		1P2W		1P3W /3P3W	1P2W		1P3W /3P3W /3P4W	1P2W		1P3W /3P3W /3P4W
		1 circuit measuring	2 circuits measuring		1 circuit measuring	2 circuits measuring		1 circuit measuring	2 circuits measuring	
Electric energy	Present value	●	●	●	●	●	●	●	●	●
Converted electric energy	Present value	—	—	—	○	○	○	●	●	●
Periodic electric energy	Present value	—	—	—	○	○	○	●	●	●
Operating time	Present value	○	○	○	○	○	○	●	●	●
Pulse count	Present value	—	—	—	○	○	○	●	●	●
Pulse converted value	Present value	—	—	—	○	○	○	●	●	●
Current demand	1,2,3,N,Total※1	●	●	●	●	●	●	●	●	●
	1,2,3,N※1	●	●	●	●	●	●	●	●	●
Electric power demand	Present value	○	○	○	○	○	○	●	●	●
	Max,Min	○	○	○	○	○	○	●	●	●
Reactive power	Present value	○	○	○	○	○	○	●	●	●
Apparent power	Present value	—	—	—	—	—	○※3	—	—	—
Reactive energy	Present value	○	—	○	○	—	○	—	—	—
Current unbalance rate	Present value	○※2	○※2	○	○※2	○※2	○	—	—	○
	Present value	○※2	○※2	○	○※2	○※2	○	—	—	○
Time	Present value	●※4	●※4	●※4	●※4	●※4	●※4	●※4	●※4	●※4
Error	—	●	●	●	●	●	●	●	●	●

※1 2 and 3 phases is not displayed in wiring setting 1P2W. N phase is only displayed in 3P4W setting.

※2 Current unbalance rate, voltage unbalance rate is displayed 0% in 1P2W setting.

※3 Apparent power is only measured in 3P4W setting.

※4 Present time is only displayed when connected EMU4-LM.

In the case monitoring by MODBUS communication.

		Model	EMU4-BM1-MB			EMU4-HM1-MB		
		Wiring type	1P2W		1P3W /3P3W	1P2W		1P3W /3P3W /3P4W
			1 circuit measuring	2 circuits measuring		1 circuit measuring	2 circuits measuring	
Electric energy	Present value	●	●	●	●	●	●	
Converted electric energy	Present value	—	—	—	●	●	●	
Periodic electric energy	Present value	—	—	—	●	●	●	
Operating time	Present value	●	●	●	●	●	●	
Pulse count	Present value	—	—	—	●	●	●	
Pulse converted value	Present value	—	—	—	●	●	●	
Current demand	1,2,3,N, total	●	●	●	●	●	●	
	1,2,3,N	●	●	●	●	●	●	
Electric power demand	Max, Min	●	●	●	●	●	●	
	Present value	●	●	●	●	●	●	
Reactive power	Present value	●	●	●	●	●	●	
	Max, Min	●	●	●	●	●	●	
Apparent power	Present value	—	—	—	—	—	—	
Reactive energy	Present value	●	—	●	—	—	—	
Current unbalance rate	Present value	●	●	●	—	—	●	
	Max	●	●	●	—	—	●	
Time	Present value	—	—	—	—	—	—	
Error	—	●	●	●	●	●	●	

In the case logging using EMU4-LM (1/2).

- ... Data can logging
- ... Data cannot logging
- △ ... Fixed Data

Elements		Model						
		EMU4-BM1-MB			EMU4-HM1-MB			
		1P2W	1P3W	3P3W	1P2W	1P3W	3P3W	3P4W
Current	Average	●	●	●	●	●	●	●
	Phase 1	●	●	●	●	●	●	●
	Phase 2	—	●	●	—	●	●	●
	Phase 3	● <sup>*1</sup>	●	●	● <sup>*1</sup>	●	●	●
	Phase N	—	—	—	—	—	—	●
Current demand	Phase 1	●	●	●	●	●	●	●
	Phase 2	—	●	●	—	●	●	●
	Phase 3	● <sup>*1</sup>	●	●	● <sup>*1</sup>	●	●	●
	Phase N	—	—	—	—	—	—	●
Voltage	Phase 1-N	△ <sup>*3</sup>	△ <sup>*3</sup>	△ <sup>*3</sup>	△ <sup>*3</sup>	△ <sup>*3</sup>	△ <sup>*3</sup>	△ <sup>*3</sup>
	Phase 2-N	△ <sup>*3</sup>	△ <sup>*3</sup>	△ <sup>*3</sup>	△ <sup>*3</sup>	△ <sup>*3</sup>	△ <sup>*3</sup>	△ <sup>*3</sup>
	Phase 3-N	△ <sup>*3</sup>	△ <sup>*3</sup>	△ <sup>*3</sup>	△ <sup>*3</sup>	△ <sup>*3</sup>	△ <sup>*3</sup>	△ <sup>*3</sup>
	Average	△ <sup>*3</sup>	△ <sup>*3</sup>	△ <sup>*3</sup>	△ <sup>*3</sup>	△ <sup>*3</sup>	△ <sup>*3</sup>	△ <sup>*3</sup>
	1-2	△ <sup>*3</sup>	△ <sup>*3</sup>	△ <sup>*3</sup>	△ <sup>*3</sup>	△ <sup>*3</sup>	△ <sup>*3</sup>	△ <sup>*3</sup>
	2-3	△ <sup>*3</sup>	△ <sup>*3</sup>	△ <sup>*3</sup>	△ <sup>*3</sup>	△ <sup>*3</sup>	△ <sup>*3</sup>	△ <sup>*3</sup>
	3-1	△ <sup>*3</sup>	△ <sup>*3</sup>	△ <sup>*3</sup>	△ <sup>*3</sup>	△ <sup>*3</sup>	△ <sup>*3</sup>	△ <sup>*3</sup>
Electric power	[1] <sup>**2</sup>	●	●	●	●	●	●	●
	[2] <sup>**2</sup>	●	—	—	●	—	—	—
Electric power demand	[1] <sup>**2</sup>	●	●	●	●	●	●	●
	[2] <sup>**2</sup>	●	—	—	●	—	—	—
Reactive power	[1] <sup>**2</sup>	●	●	●	●	●	●	●
	[2] <sup>**2</sup>	●	—	—	●	—	—	—
Apparent power		—	—	—	—	—	—	●
Power factor	[1] <sup>**2</sup>	△ <sup>*3</sup>	△ <sup>*3</sup>	△ <sup>*3</sup>	△ <sup>*3</sup>	△ <sup>*3</sup>	△ <sup>*3</sup>	△ <sup>*3</sup>
	[2] <sup>**2</sup>	△ <sup>*3</sup>	△ <sup>*3</sup>	△ <sup>*3</sup>	△ <sup>*3</sup>	△ <sup>*3</sup>	△ <sup>*3</sup>	△ <sup>*3</sup>
Frequency		△ <sup>*3</sup>	△ <sup>*3</sup>	△ <sup>*3</sup>	△ <sup>*3</sup>	△ <sup>*3</sup>	△ <sup>*3</sup>	△ <sup>*3</sup>
Current unbalance rate		—	●	●	—	●	●	●
Voltage unbalance rate		△ <sup>*3</sup>	△ <sup>*3</sup>	△ <sup>*3</sup>	△ <sup>*3</sup>	△ <sup>*3</sup>	△ <sup>*3</sup>	△ <sup>*3</sup>

In the case logging using EMU4-LM (2/2).

- ... Data can logging
- ... Data cannot logging
- △ ... Fixed Data

Elements				Model							
				EMU4-BM1-MB			EMU4-HM1-MB				
				1P2W	1P3W	3P3W	1P2W	1P3W	3P3W	3P4W	
Harmonics total current	RMS	Average Basic 3~13 <sup>th</sup>	Phase 1	△ <sup>*3</sup>	△ <sup>*3</sup>	△ <sup>*3</sup>	△ <sup>*3</sup>	△ <sup>*3</sup>	△ <sup>*3</sup>	△ <sup>*3</sup>	△ <sup>*3</sup>
			Phase 2	△ <sup>*3</sup>	△ <sup>*3</sup>	△ <sup>*3</sup>	△ <sup>*3</sup>	△ <sup>*3</sup>	△ <sup>*3</sup>	△ <sup>*3</sup>	△ <sup>*3</sup>
			Phase 3	△ <sup>*3</sup>	△ <sup>*3</sup>	△ <sup>*3</sup>	△ <sup>*3</sup>	△ <sup>*3</sup>	△ <sup>*3</sup>	△ <sup>*3</sup>	△ <sup>*3</sup>
			Phase N	△ <sup>*3</sup>	△ <sup>*3</sup>	△ <sup>*3</sup>	△ <sup>*3</sup>	△ <sup>*3</sup>	△ <sup>*3</sup>	△ <sup>*3</sup>	△ <sup>*3</sup>
	Distortion ratio	Average 3~13 <sup>th</sup>	Phase 1	△ <sup>*3</sup>	△ <sup>*3</sup>	△ <sup>*3</sup>	△ <sup>*3</sup>	△ <sup>*3</sup>	△ <sup>*3</sup>	△ <sup>*3</sup>	△ <sup>*3</sup>
			Phase 2	△ <sup>*3</sup>	△ <sup>*3</sup>	△ <sup>*3</sup>	△ <sup>*3</sup>	△ <sup>*3</sup>	△ <sup>*3</sup>	△ <sup>*3</sup>	△ <sup>*3</sup>
			Phase 3	△ <sup>*3</sup>	△ <sup>*3</sup>	△ <sup>*3</sup>	△ <sup>*3</sup>	△ <sup>*3</sup>	△ <sup>*3</sup>	△ <sup>*3</sup>	△ <sup>*3</sup>
			Phase N	△ <sup>*3</sup>	△ <sup>*3</sup>	△ <sup>*3</sup>	△ <sup>*3</sup>	△ <sup>*3</sup>	△ <sup>*3</sup>	△ <sup>*3</sup>	△ <sup>*3</sup>
Harmonics total voltage	RMS	Average Basic 3~13 <sup>th</sup>	Phase 1-N	△ <sup>*3</sup>	△ <sup>*3</sup>	△ <sup>*3</sup>	△ <sup>*3</sup>	△ <sup>*3</sup>	△ <sup>*3</sup>	△ <sup>*3</sup>	△ <sup>*3</sup>
			Phase 2-N	△ <sup>*3</sup>	△ <sup>*3</sup>	△ <sup>*3</sup>	△ <sup>*3</sup>	△ <sup>*3</sup>	△ <sup>*3</sup>	△ <sup>*3</sup>	△ <sup>*3</sup>
			Phase 3-N	△ <sup>*3</sup>	△ <sup>*3</sup>	△ <sup>*3</sup>	△ <sup>*3</sup>	△ <sup>*3</sup>	△ <sup>*3</sup>	△ <sup>*3</sup>	△ <sup>*3</sup>
			Phase N	△ <sup>*3</sup>	△ <sup>*3</sup>	△ <sup>*3</sup>	△ <sup>*3</sup>	△ <sup>*3</sup>	△ <sup>*3</sup>	△ <sup>*3</sup>	△ <sup>*3</sup>
			1-2	△ <sup>*3</sup>	△ <sup>*3</sup>	△ <sup>*3</sup>	△ <sup>*3</sup>	△ <sup>*3</sup>	△ <sup>*3</sup>	△ <sup>*3</sup>	△ <sup>*3</sup>
			2-3	△ <sup>*3</sup>	△ <sup>*3</sup>	△ <sup>*3</sup>	△ <sup>*3</sup>	△ <sup>*3</sup>	△ <sup>*3</sup>	△ <sup>*3</sup>	△ <sup>*3</sup>
	Distortion ratio	Average 3~13 <sup>th</sup>	Phase 1-N	△ <sup>*3</sup>	△ <sup>*3</sup>	△ <sup>*3</sup>	△ <sup>*3</sup>	△ <sup>*3</sup>	△ <sup>*3</sup>	△ <sup>*3</sup>	△ <sup>*3</sup>
			Phase 2-N	△ <sup>*3</sup>	△ <sup>*3</sup>	△ <sup>*3</sup>	△ <sup>*3</sup>	△ <sup>*3</sup>	△ <sup>*3</sup>	△ <sup>*3</sup>	△ <sup>*3</sup>
			Phase 3-N	△ <sup>*3</sup>	△ <sup>*3</sup>	△ <sup>*3</sup>	△ <sup>*3</sup>	△ <sup>*3</sup>	△ <sup>*3</sup>	△ <sup>*3</sup>	△ <sup>*3</sup>
			1-2	△ <sup>*3</sup>	△ <sup>*3</sup>	△ <sup>*3</sup>	△ <sup>*3</sup>	△ <sup>*3</sup>	△ <sup>*3</sup>	△ <sup>*3</sup>	△ <sup>*3</sup>
2-3	△ <sup>*3</sup>	△ <sup>*3</sup>	△ <sup>*3</sup>	△ <sup>*3</sup>	△ <sup>*3</sup>	△ <sup>*3</sup>	△ <sup>*3</sup>	△ <sup>*3</sup>			
Electric energy	Consumption	[1] <sup>*2</sup>	●	●	●	●	●	●	●	●	
		[2] <sup>*2</sup>	●	—	—	●	—	—	—	—	
	Regenerated	[1] <sup>*2</sup>	△ <sup>*3</sup>	△ <sup>*3</sup>	△ <sup>*3</sup>	△ <sup>*3</sup>	△ <sup>*3</sup>	△ <sup>*3</sup>	△ <sup>*3</sup>	△ <sup>*3</sup>	
		[2] <sup>*2</sup>	△ <sup>*3</sup>	△ <sup>*3</sup>	△ <sup>*3</sup>	△ <sup>*3</sup>	△ <sup>*3</sup>	△ <sup>*3</sup>	△ <sup>*3</sup>	△ <sup>*3</sup>	
	Consumption (expanded)			—	—	—	—	—	—	—	
	Regenerated (expanded)			—	—	—	—	—	—	—	
Reactive energy	Consumption delay			●	●	●	●	●	●	●	
	Consumption delay (expanded)			—	—	—	—	—	—	—	
Electric energy conversion				—	—	—	—	—	—	—	
Operating time				—	—	—	—	—	—	—	
Periodic electric energy				—	—	—	●	●	●	●	
Pulse count				—	—	—	●	●	●	●	
Pulse conversion				—	—	—	●	●	●	●	

\*1: Shows second circuit (3 side circuit) when setting 2 circuits measuring in 1P2W.

\*2: [1] shows first circuit when setting 2 circuits measuring in 1P2W. It is displayed when not setting 2 circuits measuring or 1P3W, 3P3W, 3P4W.[2] shows second circuit (3 side) when setting 2 circuits measuring in 1P2W.

\*3: The Logging data is setup value or fixed value.

### 7.3.2 Restriction of measured data in simple measuring

Measurement and communication do not performed in a few seconds (about 10seconds) after the power loading to this device. Measurement and communication do not performed in a few seconds after the configuration or the change of the rating to it. Behaviors during operation are as follows.

Measuring item	Behaviors of this unit
	Indication of Small-size Display Unit
Current	Current is 0A when input current is lower than cut-off setup value.
Power Reactive power Apparent power	Indicate "0W", "0var" or "0VA" if indicated current values of all phases are 0A.
Pulse converted value	When use of upper / lower limit alarm = on and upper / lower limit alarm element = pulse count (upper limit), it is fixed to 999999 when 999999 have been exceeded. When use of upper / lower limit alarm = OFF or upper / lower limit alarm element ≠ pulse count (upper limit), counting restarts from 0 when 999999 have been exceeded.
Operating time	Indicate "999999h" if operating time is over 999999h.
Current unbalance rate	Indicate "9999.99" if operating time is over 9999.99.

7.3.3 Example of wiring in using simple measuring function

When UL compliance is necessary		When UL compliance is unnecessary	
Usable current sensor		Usable current sensor	
Models	Support	Models	Support
EMU-CT50	○	EMU-CT50	○
EMU-CT100	○	EMU-CT100	○
EMU-CT250	○	EMU-CT250	○
EMU-CT400	○	EMU-CT400	×
EMU-CT600	○	EMU-CT600	×
EMU-CT5-A	○	EMU-CT5-A	×
EMU-CT50-A	○	EMU-CT50-A	×
EMU-CT100-A	○	EMU-CT100-A	×
EMU-CT250-A	○	EMU-CT250-A	×
EMU-CT400-A	○	EMU-CT400-A	○
EMU-CT600-A	○	EMU-CT600-A	○
EMU2-CT5	○	EMU2-CT5	○
EMU2-CT5-4W	×*1	EMU2-CT5-4W	○

remark: Connection with general wire (for models with ○), Connection with dedicated cable (for models with ×)

\*1: EMU2-CT5-4W is used only 3phase-4wire system.

1P2W	1P3W 3P3W
<p>Power supply side</p> <p>Load side</p> <p>RS-485(MODBUS RTU)</p>	<p>Power supply side</p> <p>Fuse 0.5A</p> <p>Load side</p> <p>RS-485(MODBUS RTU)</p>
<p>Power supply side</p> <p>Load side</p> <p>RS-485(MODBUS RTU)</p>	<p>Power supply side</p> <p>Fuse 0.5A</p> <p>Load side</p> <p>RS-485(MODBUS RTU)</p>

## 8. Device operation

### 8.1 Resolution of measuring data

The resolution of measuring data is determined as follows according to the rating settings (phase wire system, primary current and primary voltage).

#### ■ Voltage, harmonic voltage RMS

Primary voltage setting	Resolution	Unit
less than 300V	1 decimal places	V
300V ~ 3000V	Integer	
3000V ~	×10	

#### ■ Current, current demand harmonic current

Primary current setting	Resolution	Unit
less than 40A	3 decimal places	A
40A ~ 400A	2 decimal places	
400A ~ 4000A	1 decimal places	
4000A ~	Integer	

#### ■ Harmonic voltage/ Harmonic voltage distortion ratio,

1 decimal places: 0.1%

#### ■ Power factor

1 decimal places: 0.1

#### ■ Frequency

1 decimal places: 0.1Hz

#### ■ power, power demand, reactive power, apparent power

Total load power	Resolution	Unit
less than 12kW	3 decimal places	kW kvar
12 kW ~ 120 kW	2 decimal places	
120 kW ~ 1200 kW	1 decimal places	
1200 kW ~ 12000 kW	Integer	
12000 kW ~ 120000 kW	×10	
120000kW ~	×100	

#### ■ Electric energy, reactive energy

Total load power	Resolution	Unit
less than 12kW	2 decimal places	kWh kvarh
12 kW ~ 120 kW	1 decimal places	
120 kW ~ 1200 kW	Integer	
1200 kW ~ 12000 kW	×10	
12000 kW ~ 120000 kW	×100	
120000kW ~	×1000	

#### ■ Electric energy(expansion), reactive energy (expansion)

Total load power	Resolution	Unit
less than 12kW	5 decimal places	kWh kvarh
12 kW ~ 120 kW	4 decimal places	
120 kW ~ 1200 kW	3 decimal places	
1200 kW ~ 12000 kW	2 decimal places	
12000 kW ~ 120000 kW	1 decimal places	
120000kW ~	Integer	

Note: Extended electric energy is the data of lower three digits more than electric energy data. The number of digits of response data is the same as the amount of electric energy data.

• The image of the Extended electric energy  
In the case measuring device has "12345.6789" as internal data.

Electric energy data : "123456"

12345.6789

Extended electric energy data : "456789"

#### ■ Electric energy converted value

The Unit depends on setting value.

Total load power	Resolution
less than 12kW	2 decimal places
12 kW ~ 120 kW	1 decimal places
120 kW ~ 1200 kW	Integer
1200 kW ~ 12000 kW	×10
12000 kW ~ 120000 kW	×100
120000kW ~ 1200000kW	×1000
1200000kW ~	×10000

#### ■ Pulse converted value

The Unit depends on setting value.

Total load power	Resolution
0.001 ~ 0.01	3 decimal places
0.01 ~ 0.1	2 decimal places
0.1 ~ 1.0	1 decimal places
1 ~ 10	Integer
10 ~ 100	×10
100 ~ 1000	×100
1000 ~	×1000

## 8.2 Restrictions of measured data

Measurement and communication do not performed in a few seconds (about 10seconds) after the power loading to this device.  
Measurement and communication do not performed in a few seconds after the configuration or the change of the rating to it.  
Behaviors during operation are as follows.

Measured item	Behaviors of this unit and Indication of Small-size Display Unit
Current	Current is 0A when input current is lower than cut-off setup value.
Voltage	Indicate "0V" if RMS value is under 11V. (*1)
Power Reactive power Apparent power	Indicate "0W", "0var" or "0VA" if indicated voltage values of all phases are 0V or indicated current values of them are 0A.
Power factor	Indicate "100.0%" if indicated voltage values of all phases are 0V or indicated current values of them are 0A.
Frequency	Voltage condition: Indicate "0Hz" if voltage V12 (voltage V1N for 3P4W) is 0V. ----- Frequency condition: Indicate "0Hz" if frequency is under 44.5Hz. Indicate "0Hz" if frequency is over 99.9Hz.
RMS value of harmonic voltage	Voltage condition: Indicate "0V" at each phase if voltage is 0V. Indicate "0V" at all phase if voltage V12 (voltage V1N for 3P4W) is 0V. 0V is displayed in each phases when displayed voltage is 0V. Indicate "0.0V" at all phase if voltage V12 (voltage V1N for 3P4W) is 0V. ----- Frequency condition: Indicate "0V" at all phases if frequency is under 44.5Hz.
Content rate of harmonic voltage (modulation distortion)	Voltage condition: Indicate "0%" at each phase if voltage is 0V. Indicate "0%" at all phase if voltage V12 (voltage V1N for 3P4W) is 0V. 0%V is displayed in each phases when displayed voltage is 0V. Indicate "0.0%" at all phase if voltage V12 (voltage V1N for 3P4W) is 0V. ----- Frequency condition: Indicate "0%" at all phases if frequency is under 44.5Hz.
RMS value of harmonic current	Current condition: Indicate "0A" at each phase if voltage is 0A. 0VA is displayed in each phases when displayed current is 0A. ----- Frequency condition: Indicate "0A" at all phases if frequency is under 44.5Hz. ----- Voltage condition: Indicate "0A" at all phase if voltage V12 (voltage V1N for 3P4W) is 0V. Indicate "0.0%" at all phase if voltage V12 (voltage V1N for 3P4W) is 0V.
Content rate of harmonic current (modulation distortion)	Harmonic current condition: Indicate "0%" at each phase if harmonic current (total) is 0A. 0% is displayed in each phases when harmonics current is 0A. ----- Frequency condition: Indicate "0%" at all phases if frequency is under 44.5Hz. ----- Voltage condition: Indicate "0V" at all phase if voltage V12 (voltage V1N for 3P4W) is 0V. Indicate "0.0%" at all phase if voltage V12 (voltage V1N for 3P4W) is 0V.
Pulse converted value	When use of upper / lower limit alarm = on and upper / lower limit alarm element = pulse count (upper limit), it is fixed to 999999 when 999999 have been exceeded. ----- When use of upper / lower limit alarm = OFF or upper / lower limit alarm element ≠ pulse count (upper limit), counting restarts from 0 when 999999 have been exceeded.
Operating time(*2)	Indicate "999999h" if operating time is over 999999h.
Current unbalance rate	Indicate "9999.99" if operating time is over 9999.99.
Voltage unbalance rate	Indicate "9999.99" if operating time is over 9999.99.

\*1: In single-phase, three-wire system, indicate "0V" if RMS value is under 22V.

\*2: Operation time is reference value.

### ✓ Supplement

- This unit takes a few seconds after change rating setup and the setup. While time measuring operation can't conduct. ( MEA\*\* : LED is turned off)
- Please reference to  7.3.2 about restriction of measured data in simple measuring mode.

## 9. Reference

This chapter explains the ways of dealing when you think the unit is in failure, Q&A, etc.

### 9.1 In case you think the unit is in failure

If an abnormal sound, bad-smelling smoke, fever break out from this unit, switch it off promptly and don't use it. If you think the unit is in failure, check the following before sending for repair.

#### Obtained value is incompatible with other values.

- Integrated electric energy value is not measured though current value is indicated.
- Obtained values are different from other measuring instruments.

Check that MEA.\*\* LED (☛ 3.2 Indication and function of LEDs) on the front panel of the main body is on. If the LED is not on, the main body is not wired or is wired incorrectly.

Check the settings of phase wire system, primary voltage and primary current. Wrong settings may cause the incorrect measurement.

Check the polarity and wiring of the current sensor in accordance with the following procedures.

Points to be checked		
①	Disconnect all current sensors, and make sure that the current value is 0 A while voltage is kept input in the unit.	If the current value is not 0 A, the sensor input circuit may have been burnt out (when a general potential transformer is directly connected), or other parts of the unit may be defective. Contact our sales representative near you.
②	Current	Check that I <sub>1</sub> is correctly measured.
	Power	Check that the electric power is correctly measured. Reference For 1P3W $W = \text{Voltage}, V_{1-2} \times \text{Current}, I_1$ For 3P3W $W = \text{Voltage}, V_{1-2} \times \text{Current}, I_1 \times \sqrt{3}/2$
③	Connect only the side 3 of the current sensor, and check the indication as stated in ②.	

Check the wiring of the voltage line.

Make sure that the wires are connected correctly to P1, P2, P3 and P0 Check the wiring both on the unit side and on the circuit connecting side.

Check whether the short circuit or disconnection is present.

#### Obtained values are different from other measuring instruments. (over tolerance)

Check that the measuring instrument used for comparison indicates a correct RMS value. This unit indicates an RMS value.

If the measuring instrument used for comparison measures an average value instead of RMS value, distortion caused by harmonic etc. in the current of the circuit to be measured causes a significant difference of values.

Current sensor connectable to the unit is the dedicated current sensor only. Check that the proper current sensor is connected or not.

#### Extinction RUN LED

Please turn OFF/ON the measuring unit. Unit may be in failure if RUN LED extinction happens again.

Contact our sales representative near you.

#### Lighting ALM A1, ALM A2

Error is occurred. Please check the error number in display unit.

## 9.2 After-sales service

If you have any questions or the product is broken down, contact our sales representative near you. (For details, refer to the end of this manual.)

- Gratis warranty is effective until the earlier of 1 year after the date of your purchase or 18 months after manufacturing.
- The gratis warranty shall apply if the product fails even though it is being used properly in the conditions, with the methods and under the environments in accordance with the terms and precautions described in the catalogs, the instruction manual, caution label on the product, etc.
- Repair shall be charged for the following cases even during the gratis warranty period.
  - Failures occurring due to your improper storage or handling, carelessness or fault.
  - Failures due to faulty workmanship
  - Failures due to faults in use and undue modification
  - Failures due to accidental force such as a fire, abnormal voltage, etc. and force majeure such as an earthquake, wind, flood, etc.
  - Failures due to matters unpredictable based on the level of science technology at the time of product.
- Our company shall not be liable to compensate for any loss arising from events not attributable to our company, opportunity loss and lost earning of the customer due to failure of the product, and loss, secondary loss, accident compensation, damage to other products besides our products and other operations caused by a special reason regardless of our company's predictability

## 9.3 Q&A

### ■General

<b>Q</b>	<b>To what degree is the unit durable against overvoltage and over current?</b>
<b>A</b>	Durability is as follows: Momentary*: Up to 20 times as high as rated current and 2 times as high as rated voltage. *Momentary means: Energizing 9 times for 0.5 seconds at 1-minute intervals, and then 1 time for 5 seconds. Continuous: Up to 1.1 times as high as rated voltage and rated current.
<b>Q</b>	<b>Can the unit be used as an electric energy meter?</b>
<b>A</b>	This unit cannot be used for deal and proof of electric energy measurement stipulated in the measurement law.
<b>Q</b>	<b>Are errors in wiring verifiable easily?</b>
<b>A</b>	They are verifiable by the indication for discrimination support function for improper connection in instruction manual (detail) of display unit.
<b>Q</b>	<b>Is it OK to open the secondary terminals of the current sensor?</b>
<b>A</b>	The secondary side of the models EMU2-CT5, EMU2-CT5-4W, EMU-CT50, EMU-CT100, EMU-CT250, EMU-CT5-A, EMU-CT50-A, EMU-CT100-A, EMU-CT250-A, EMU-CT400-A, and EMU-CT600A is equipped with the protective circuit against opening of secondary terminals. Opening them during the wiring work causes no problems. However, for safety, please do not continuously energize the module with the terminals open. The secondary side of the models EMU-CT400 and EMU-CT600 is equipped with the protective circuit against opening of secondary terminals. However, during the wiring work, be sure to turn the secondary side short-circuit switch to short. After completion of work, be sure to turn the secondary short-circuit switch to open. Note that failing to turn the switch open results in an inaccurate measurement.
<b>Q</b>	<b>If a load such as welding equipment exists, a current flows only for a short period (e.g. 2 cycles). Is measurement possible?</b>
<b>A</b>	The electrical amount such as current, voltage, electric power, power factor, frequency, harmonic voltage and harmonic current is measured in a cycle of 100 ms period. So it is impossible to measure the current accurately for a short period. The amount of electricity and reactive power amount are measured separately from the momentary data described above, using a sampling period of 4kHz continuously without intermittence. Therefore, it is possible to measure the load for a short period.
<b>Q</b>	<b>Obtained values may be different from other measuring instruments. Why is it so?</b>
<b>A</b>	There are various possible causes. Check the following first, please: (1) Check for wiring errors.(Especially, polarity of current sensor and connection of voltage circuit) (2) Check for the settings. (phase wires, primary voltage ,primary current and sensor type) (3) On the split-type current sensor, check for the poor engagement or separation of fitting surfaces. (4) On the split-type current sensor, check for pinching of foreign object between fitting surfaces. (5) Check for the short circuit on the secondary side of the current transformer (CT). (6) Current sensor connectable to the unit is the dedicated current sensor only. Check that the proper current sensor is connected or not. (7) Check that the measuring instrument used for comparison indicates a correct RMS value. This unit indicates an RMS value. If the measuring instrument used for comparison measures an average value instead of RMS value, distortion caused by harmonic etc. in the current of the circuit to be measured causes a significant difference of values.

### ■Q&A about specifications



<b>Q</b>	<b>What does “Allowable tolerance” mean?</b>
<b>A</b>	In terms of the amount of electricity, it means a range of tolerances in reading values. For example, when the reading value is “10 kWh,” a tolerance is $\pm 0.2$ kWh. In terms of measured elements other than the amount of electricity, it means tolerance for the rated input. For a current, when a rated current is set to 250 A, $2.5A(\pm 1\%)$ is a tolerance.
<b>Q</b>	<b>Is accuracy of a current sensor included?</b>
<b>A</b>	Accuracy of a current sensor is not included in accuracy of the unit. A maximum value of tolerance is obtained by summing tolerance of the unit and that of a current sensor.
<b>Q</b>	<b>To what degree an area of micro current is measured?</b>
<b>A</b>	A current value is measured from the area exceeding 0.4% of the rated current. In an area below 0.4%, measurement result is indicated as “0” (zero). However, in that case, still, the amount of electricity is being measured. Even if the indicated value is “0,” measurement value will increase in continuing measurement for a long time. The amount of electricity is measured with a load that is about 0.4% or more of all load power. Current value is measured when it is more than setup value of cut-off. Measured value is 0 when it is less than setup value of cut-off. Measured value of electric energy value is increased even though displayed current is 0, because electric energy measuring is conducted. Electric energy is measured when the load is more than about 0.4% of full load.
<b>Q</b>	<b>Is measurement of inverter circuit possible?</b>
<b>A</b>	Measuring the secondary side of the inverter is impossible due to the large fluctuation of frequency. Make measurement on the primary side of the inverter. However, since a current waveform on the primary side of the inverter has a distortion containing the harmonic components, a slight error occurs.

#### ■Q&A about installation

<b>Q</b>	<b>What is wire diameter that allows installing a current sensor?</b>
<b>A</b>	The following lists the nominal cross-sectional areas of the conductor of 600-V vinyl coated wires that can penetrate. (values for reference) <ul style="list-style-type: none"> <li>· IV wire (600-V vinyl insulated wire) 38mm<sup>2</sup> (EMU-CT50-A)、60mm<sup>2</sup> (EMU-CT50/CT100, EMU-CT100-A)、150mm<sup>2</sup> (EMU-CT250) 200mm<sup>2</sup> (EMU-CT250-A)、500mm<sup>2</sup> (EMU-CT400-A, EMU-CT600-A)、500 mm<sup>2</sup>×1wire、325 mm<sup>2</sup>×2wire (EMU-CT400/CT600)</li> <li>· CV wire (600-V vinyl insulated wire) 22mm<sup>2</sup> (EMU-CT50-A) , 38mm<sup>2</sup> (EMU-CT50/CT100), 60mm<sup>2</sup> (EMU-CT100-A) , 150mm<sup>2</sup> (EMU-CT250 (100mm<sup>2</sup> is recommended), EMU-CT250A) 400mm<sup>2</sup> (EMU-CT400-A, EMU-CT600-A) , 500 mm<sup>2</sup> x 1 wire, 325 mm<sup>2</sup> x 2 wires (EMU-CT400/CT600)</li> </ul> The above shows the standard nominal cross-sectional areas. Due to the outer difference of finished vinyl insulation and deformation (bending) depending on manufacturers, a wire may not penetrate. Make verification on site.
<b>Q</b>	<b>What are the points when installing a current sensor?</b>
<b>A</b>	Models EMU2-CT5, EMU2-CT5-4W, EMU-CT***, EMU-CT***-A and EMU-CT5-A are split-type. If split surfaces are not engaged sufficiently or a foreign object exists between the split surfaces, adequate performances are not obtained. Pay attention in installation.

## ■Q&A about connection

<b>Q</b>	<b>Does polarity exist in connection between a current sensor and the unit?</b>
<b>A</b>	Yes. Make connections so that secondary terminals of current sensor (k, l) and terminal symbols of unit agree with each other. If polarity is incorrect, the current value is measurable, but the electric power and the electrical energy cannot be measured correctly.
<b>Q</b>	<b>Are there any key points in avoiding errors in wiring?</b>
<b>A</b>	Check polarity of current sensor on the primary current side. Power supply side of the circuit is indicated as "K," and the load is indicated as "L." An arrow indicates the direction from K to L. Check the current sensor and the module are connected correctly for the 1-side circuit, 2-side circuit, and 3-side circuit. Besides, check that voltage inputs for voltage transform unit are connected correctly among P1, P2, P3, and P0.
<b>Q</b>	<b>How do wires extend between a current sensor and the module?</b>
<b>A</b>	Model EMU-CT***, EMU-CT***-A are extendable up to 50m. Model EMU2-CT5, EMU2-CT5-4W are extendable up to 11 m, using together with a extension cable. To extend the wire further, use the current transformer CW-5S(L) for split-type instrument in combination, extending the secondary wiring on CW-5S(L) side.

## ■Q&A about setting

<b>Q</b>	<b>Is the setting required?</b>
<b>A</b>	At least, settings of phase wires, primary current and primary voltage are required. Specify settings in accordance with a circuit to be connected. To set this unit, dedicated small-size display unit (EMU4-D65) is necessary.
<b>Q</b>	<b>If a primary current setting value is different from that of rated current on a connected current sensor, does it cause a breakdown?</b>
<b>A</b>	It does not cause breakdown or burning. However, measurement values will be totally incorrect.

## 10. Requirement for the compliance with EMC Directives EMC

EMC Directives prescribe both "Emission (electromagnetic interference): Do not radiate strong electromagnetic waves outside" and "Immunity (electromagnetic susceptibility): Do not be influenced by electromagnetic waves from outside".

This section compiles the precautions for the compliance of the system incorporating the energy measuring unit (target model: EMU4-BM1-MB and EMU4-HM1-MB) with the EMC Directives. The following description is based on the requirement of the regulations and the standards we understand, but we do not guarantee to comply with the directives above for the whole system built in accordance with this description. The manufacturer of the system finally needs to evaluate the way of the compliance with EMC Directives and whether the system complies with them or not.

- (1) Harmonized standard for EMC Directives: EN61326-1:2013
  - (a) Compatibility condition for harmonized standard

The energy measuring unit is the open type device (i.e. the device incorporated in other device), and needs to be installed in the conductive control panel. The unit is tested with installed in the control panel for the emission and the immunity out of the test items for the standard.
  - (2) Recommended condition for installation in the control panel
    - (a) Control panel
      - Control panel needs to have conducting property.
      - When bolting the top panel, bottom panel etc. of the control panel, mask the grounding part of the panel so as not to be painted.
      - In inner panel, keep the conductivity in as large area as possible by masking the bolting part to the main panel to keep the electric contact to main panel.
      - Ground the main panel by the thick wire so as to keep high impedance even for high-frequency wave.
    - (b) Installation of power line and ground line
      - Set up the ground point to the control panel near the energy measuring unit, and ground the frame GND terminal of the unit to the ground terminal of the control panel (PE) by as thick and short wires as possible. (wire length is 30cm or shorter)
- (3) Cable
  - (a) Auxiliary power, Input voltage, CC-Link cable, MODBUS cable, Small display unit cable

When it is necessary to comply with the EMC Directive (EN-61326-1), attach ferrite cores to each cable. Ferrite cores used in our testing is below.

    - Auxiliary power  
KITAGAWA INDUSTRIES CO.,LTD., RFC-H13  
KITAGAWA INDUSTRIES CO.,LTD., TRM-31-20-15E-WE
    - Input voltage  
KITAGAWA INDUSTRIES CO., LTD., RFC-H13
    - CC-Link cable, MODBUS cable  
KITAGAWA INDUSTRIES CO., LTD., RFC-20
    - Small display unit cable  
KITAGAWA INDUSTRIES CO.,LTD., RFC-H13
  - (b) External input signal line, External output signal line

Wiring of each connection wire should satisfy the following conditions.

    - For wiring inside buildings, the wiring length should not exceed 30 m.
    - Do not route wiring from the inside of the building to the outside of the building.

# 11. Specifications

## 11.1 Common specifications

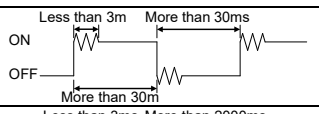
Item		Specifications		
Model		EMU4-BM1-MB	EMU4-HM1-MB	
Phase-wire system		Single-phase 2-wire / Single-phase 3-wire / Three-phase 3-wire (Change of setting)	Single-phase 2-wire / Single-phase 3-wire / Three-phase 3-wire / Three-phase 4-wire(Change of setting)	
Rating	110V, 220V AC(*1)	110V, 220V, 440V AC(*2)	110V, 220V, 440V AC(*2)	
	Single-phase 3-wire	110V AC (b/w 1- and 2-phase, 2- and 3-phase) 220V AC (b/w 1- and 3-phase)	110V AC (b/w 1- and 2-phase, 2- and 3-phase), 220V AC (b/w 1- and 3-phase) 220V AC(b/w 1- and 2-phase, 2- and 3-phase), 440V AC (b/w 1- and 3-phase)	
	Three-phase 4-wire	-	Min: 63.5V/110V AC, Max: 277V/480V AC(*3)	
	Current circuit (*1)	50A, 100A, 250A, 400A, 600A AC (The dedicated split type current sensor is used. Each value refers to the current at the primary side of the current sensor.) 5A AC (The dedicated split type current sensor is used. 5A current sensor is used together with the current transformer (CT), and the primary-side current is configurable up to 30000A.) Secondary current Max.:66.66mA		
Frequency		50Hz / 60Hz (Auto-detect)		
Auxiliary power supply rating		100V - 240V AC (+10%, -15%) 50Hz / 60Hz 10VA Transient voltage 4000V		
Measurable circuit count		1 circuit * 2 circuits when 2circuits measuring setup and 1P2W wiring		
Consumption VA	Voltage circuit	Each phase 0.1VA (at 110V AC), 0.2VA (at 220V AC), 0.4VA (at 440V AC)	Each phase 0.1VA(AC11V), 0.2VA(AC220V), 0.4VA(AC440V)	
	Auxiliary power supply circuit	At 110V AC : 2.0VA At 220V AC : 3.0VA		
Allowable tolerance		Current, voltage, electric power, reactive power, apparent power, frequency : ±1.0% (100% of the rating) Power factor : ±3.0% Electric energy : ±2.0% (5 - 100% range of the rating, power factor=1) Reactive energy : ±2.5% (10 - 100% range of the rating, power factor=0) Harmonic current, harmonic voltage (*2) : ±2.5%		
Data update interval		100msec *Integrated values of electric energy and reactive energy are always accumulated (following up the short-cycled load fluctuation)		
Range of demand time setting		0, 10s, 20s, 30s, 40s, 50s, 1 - 15min (1min intervals), 20min, 25min, 30min		
External input	Input signal	-	Non-voltage Form A contact, or open collector 1 input (choose the function from below)	
	Function	-	Setting to "pulse input": Pulse count (0 - 999,999 counts)	
		-	Setting to "contact input": Contact monitoring only : Contact monitoring and energy measuring at work (when contact is on)	
	Isolation	-	By semiconductor relay	
	Rated input voltage and current		-	Voltage of the contact is 5V DC, and current is 7mA, so use something appropriate for the switching condition.
	Input condition	Pulse	-	Pulse ON time: 30ms or longer Pulse OFF time: 30ms or longer Chattering time: 3ms or shorter 
Contact		-	Contact ON time: 2000ms or longer Contact OFF time: 2000ms or longer Chattering time: 3ms or shorter 	
External output	Output signal	-	Non-voltage Form A contact, 1 output (choose the function from below)	
	Function	Element of alarm	-	Upper limit monitoring of current demand, Lower limit monitoring of current demand, Upper/Lower limit monitoring of voltage, Upper limit monitoring of power demand, Lower limit monitoring of power demand, Upper limit monitoring of power factor, Lower limit monitoring of power factor, Upper limit monitoring of pulse count, Upper limit monitoring of current unbalance rate, Upper limit monitoring of voltage unbalance rate
		Alarm reset method	-	Selectable from either auto-reset or self-retention
	Isolation	-	By semiconductor relay	
	Rated switching voltage and current		-	35V DC, 75mA 24V AC, 75mA (power factor = 1)

Pulse output	Output element	-	Electric energy
	Output signal	-	Non-voltage Form A contact, 1 output (*6) • Unit of pulse (kWh / pulse): 0.001 / 0.01 / 0.1 / 1 / 10 / 100
	Isolation	-	By semiconductor relay
	Rated switching voltage and current	-	35V DC, 75mA 24V AC, 75mA (power factor = 1)
	Output pulse width	-	0.1 – 0.15s
Compensation for power failure	Stored items	Setting values, Electric energy (consumption, regeneration), reactive energy, periodic electric energy, pulse count value, alarm count (stored in the nonvolatile memory), max value, min value	

Item		Specifications	
Model		EMU4-BM1-MB	EMU4-HM1-MB
Standard		CE Marking (EMC: EN-61326-1: 2013, Safety: EN-61010-1: 2010), UL: UL61010-1	
Usage environment	Operating temperature	-5 - +55°C (Daily average temperature is 35°C or lower)	
	Operating humidity	30 - 85%RH (No condensation)	
	Storage temperature	-10 - +60°C	
	Operating altitude	2000m or below	
Commercial frequency withstand voltage		B/w all terminals (except for communication circuit and frame GND terminal) and casing: 2000V AC, 1min	
		B/w all terminals of current input, voltage input / auxiliary power : 2000V AC, 1min	
		B/w all terminals of current input, voltage input, auxiliary power and all terminals of digital / pulse input, pulse / alarm output, communication: 2000V AC, 1min	
Insulation resistance		10M $\Omega$ or more at the same part above (500V DC)	
Appropriate wire	Terminals of auxiliary power circuit and voltage input	AWG22-16(single/stranded) (Single: $\phi$ 0.65- $\phi$ 1.25mm, stranded: 0.3-1.3mm <sup>2</sup> )	AWG22-16single/stranded (Single: $\phi$ 0.65- $\phi$ 1.25mm, stranded: 0.3-1.3mm <sup>2</sup> )
	Terminals of MODBUS communication	SPEV(SB) – MPC – 0.2×1P	
	Terminals of external input/output <sup>**7</sup>	-	AWG26-16(single/stranded) (Single: $\phi$ 0.5- $\phi$ 1.2mm, stranded: 0.5-1.3mm <sup>2</sup> )
	Terminals of current input and input/output	stranded: AWG20-16 (Strand wires: 0.5-1.3mm <sup>2</sup> ) Single: AWG24-17 (Single line: $\phi$ 0.5- $\phi$ 1.2mm)	
Tightening torque	Screws for terminals of auxiliary power circuit and voltage input	0.8 - 1.0N·m	0.8 - 1.0N·m
	Screws for terminals of MODBUS communication and External input/output <sup>**7</sup>	0.5 - 0.6N·m	
Mass		0.2kg	
External dimensions (unit: mm)		37.5 (W) x 90 (H) x 94 (D) (expect for the protruding portions) (Maximum dimension including the protruding portions: 41.5 (W) x 99 (H) x 94 (D))	

※1: 110V, 220V AC can connected to this unit directly. For the circuit over this voltage, transformer (VT) is necessary (primary voltage of the transformer is up to 110000V). The transformer of star - delta connection and delta - star connection can't measure correctly because of the phase shifting. Please use transformer of same wire connection.

※2: 110V, 220V, 440V AC can connected to this unit directly. For the circuit over this voltage, transformer (VT) is necessary. (Primary voltage of the transformer is up to 110000V) The transformer of star - delta connection and delta - star connection can't measure correctly because of the phase shifting. Please use transformer of same wire connection.

※3: 63.5/110V – 277/480V AC can connected to this unit directly. For the circuit over this voltage, transformer (VT) is necessary. (Primary voltage of the transformer is up to 110000V (line voltage)) The transformer of star - delta connection and delta - star connection can't measure correctly because of the phase shifting. Please use transformer of same wire connection.

※4: VT ratio can be setup arbitrarily for special VT ratio in below range when wiring type is setup 1P2W, 3P3W, 3P4W.

Primary voltage of VT is 1~110000V(1Vstep), and secondary voltage is 1~220V(1Vstep).

※5: CT ratio can be setup arbitrarily for special CT ratio in below range.

Primary current of CT is 1~30000A(1A step). Secondary current of CT is hold 5A.

※6: The pulse output unit changes by the full load power.

Full load power (kW)	Setting range			
Less than 12kW	1	0.1	0.01	0.001
12kW ~ 120kW	10	1	0.1	0.01
120kW ~ 1200kW	100	10	1	0.1
1200kW ~ 12000kW	1000	100	10	1
12000kW ~ 120000kW	10000	1000	100	10
120000kW ~	100000	10000	1000	100

※7: The terminal for extra input is EMU4-HM1-MB only.

※8: When combine this unit with a CT (Model : EMU2-CT5, EMU2-CT5-4W, EMU-CT50, EMU-CT100, EMU-CT250, EMU-CT400-A, EMU-CT600-A), it becomes UL standard.

※9: CC-Link Communication Unit produced after December, 2015 confirms UL in combination with EcoMonitorPlus.

## 11.2 Specifications of MODBUS communications

Item	Specifications
Physical interface	RS-485 2wires half duplex
Protocol	MODBUS RTU mode
Transmission method	Asynchronous
Transmission wiring type	Multi-point bus (either directly on the trunk cable, forming a daisy-chain)
Baud rate	2400, 4800, 9600, 19200, 38400bps (default: 19200bps)
Data bit	8
Stop bit	1, 2 (default: 1)
Parity	ODD,EVEN,NONE (default: EVEN)
Slave address	1~255 (FFh) (default: 1) 0: Broadcast
Response time	1s or shorter from completion of receiving query data to response transmission
Transmission distance	1200m
Maximum connectable devices	31 devices
Termination resistor	120Ω 1/2W
Recommended cable	SPEV(SB)-MPC-0.2 × 1P (Fujikura Dia Cable)

## 12. Option devices

### 12.1 About option devices

Option devices of this unit are showed below. Please reference to manual of option devices.

Product name	Model	Note	
Extention unit	Energy Measuring Unit Extension for the systems with the same voltage	EMU4-A2 You can monitor Multi-circuit in same voltage system to extension main unit. Up to 3 units can be connected in energy measure unit.	
	Energy Measuring Unit Extension for the systems with the different voltage	EMU4-VA2 You can monitor Multi-circuit in different voltage system to extension main unit. Up to 3 units can be connected in energy measure unit.	
	Energy Measuring Unit Energy Measuring Extension Model for Pulse Input	EMU4-PX4 You can monitor at most 4 circuits of pulse/a contact input system to extension main unit. When data exceeded the established upper limit value, indication of LEDs and contact output are performed.	
	Energy Measuring Unit Energy Measuring Extension Model for Analog Input	EMU4-AX4 You can monitor at most 4 circuits of analog input (0-+5V/0-+20mA) system to extension main unit. When data exceeded the set upper limit value, indication of LEDs and contact output are performed.	
Option unit	CC-Link Communication Unit for Energy Measuring Unit	EMU4-CM-C You can use CC-Link communication by connecting main unit.	
	Logging Unit for Energy Measuring Unit	EMU4-LM You can log the measured data by connecting main unit.	
	CC-Link IE Field Basic Communication Unit for Energy Measuring Unit	EMU4-CM-CIFB You can use CC-Link IE Field Network Basic Communication by connecting main unit.	
	Small-size Display Unit for Energy Measuring Unit	EMU4-D65 You can display the measured data and use for setup.	
Peripheral equipment	Current sensor	EMU-CT50 EMU-CT50-A	50A split type
		EMU-CT100 EMU-CT100-A	100A split type
		EMU-CT250 EMU-CT250-A	250A split type
		EMU-CT400 EMU-CT400-A	400A split type
		EMU-CT600 EMU-CT600-A	600A split type
		EMU-CT5-A	5A split type
		EMU2-CT5	5A split type (1P2W, 1P3W, 3P3W)
		EMU2-CT5-4W	5A split type (3P4W)
	Split type 5A current sensor cable	EMU2-CB-Q5A	Connect to current input terminal for 1P2W, 1P3W, 3P3W.
		EMU2-CB-Q5A-4W	Connect to current input terminal for 3P4W.
		EMU2-CB-T1M	Extension cable(Standard type) 1m
		EMU2-CB-T5M	Extension cable(Standard type) 5m
		EMU2-CB-T10M	Extension cable(Standard type) 10m
		EMU2-CB-T20M	Extension cable(Standard type) 20m
		EMU2-CB-T1MS	Extension cable(Separate type) 1m
		EMU2-CB-T5MS	Extension cable(Separate type) 5m
EMU2-CB-T10MS	Extension cable(Separate type) 10m		

## 12.2 Specifications of option devices

### (1) Split type current sensor

Item	Specifications				
Model	EMU-CT50	EMU-CT100	EMU-CT250	EMU-CT400	EMU-CT600
Rated primary current	50AAC	100AAC	250AAC	400AAC	600AAC
Rated secondary current	16.66mA	33.33mA	66.66mA	66.66mA	66.66mA
Rated load	0.1VA				
Maximum operating voltage	460V AC				
Relative error	±1% (5 - 100% range of rating, RL ≤ 10Ω)				
Variability of phase difference	±30° (5 - 100% range of rating, RL ≤ 10Ω)				
Over voltage category	III				
Pollution degree	2				
Operating temperature	-5 - +55°C (Daily average temperature is 35°C or lower)				
Operating humidity	5 - 95%RH (No condensation)				
Standard for CE marking	EN61010-2-32				
Maximum operating voltage for compliance with CE marking	460V AC				
Mass (per device)	0.1kg			0.7kg	

\*Use an electric wire of the size of penetrating this current sensor for a primary side cable, do not use a non-insulation electric wire or a metal for a primary cable.

\* EMU-CT400 and EMU-CT600 are product stop January 2017.

Item	Specifications				
Model	EMU-CT50-A	EMU-CT100-A	EMU-CT250-A	EMU-CT400-A	EMU-CT600-A
Rated primary current	50AAC	100AAC	250AAC	400AAC	600AAC
Rated secondary current	16.66mA	33.33mA	66.66mA	66.66mA	66.66mA
Rated load	0.1VA				
Maximum operating voltage	460V AC				
Relative error	±1% (5 - 100% range of rating, RL ≤ 10Ω)				
Variability of phase difference	±45° (10%-100% of rating, RL ≤ 10Ω) ±60° (5% of rating, RL ≤ 10Ω)		±40° (5%-100% of rating, RL ≤ 10Ω)		
z					
Over voltage category	-			III	
Pollution degree	-			2	
Operating temperature	-5 - +55°C (Daily average temperature is 35°C or lower)				
Operating humidity	30 - 85%RH (No condensation)				
Standard for CE marking	-			EN61010-2-32	
Maximum operating voltage for compliance with CE marking	-			460V AC	
Mass (per device)	0.05kg	0.1kg	0.2kg	0.3kg	0.4kg

\*Use an electric wire of the size of penetrating this current sensor for a primary side cable, do not use a non-insulation electric wire or a metal for a primary cable.



## (2) 5A current sensor

Item	Specifications	
Model	EMU2-CT5, EMU2-CT5-4W	EMU-CT5-A
Rated primary current	5AAC	
Rated secondary current	1.66mA	
Rated load	0.1VA	
Maximum operating voltage	260V AC	460V AC
Relative error	±1% (5 - 100% range of rating)	±1% (5 - 100% range of rating, RL ≤ 10Ω)
Variability of phase difference	±30° (5%-100% of rating, RL ≤ 10Ω)	±45° (10%-100% of rating, RL ≤ 200Ω) ±60° (5% of rating, RL ≤ 200Ω)
Over voltage category	III	-
Pollution degree	2	-
Operating temperature	-5 - +55°C (Daily average temperature is 35°C or lower)	-5 - +55°C (Daily average temperature is 35°C or lower)
Operating humidity	5 - 95%RH (No condensation)	30 - 85%RH (No condensation)
Standard for CE marking	EN61010-2-32	-
Maximum operating voltage for compliance with CE marking	260V AC	-
Mass (per device)	0.1kg	0.05kg

\*Use an electric wire of the size of penetrating this current sensor for a primary side cable, do not use a non-insulation electric wire or a metal for a primary cable.

### 12.3 External dimensions of option devices

Unit: mm

#### ■ Energy Measuring Unit Extension for the systems with the same voltage (Model: EMU4-A2)

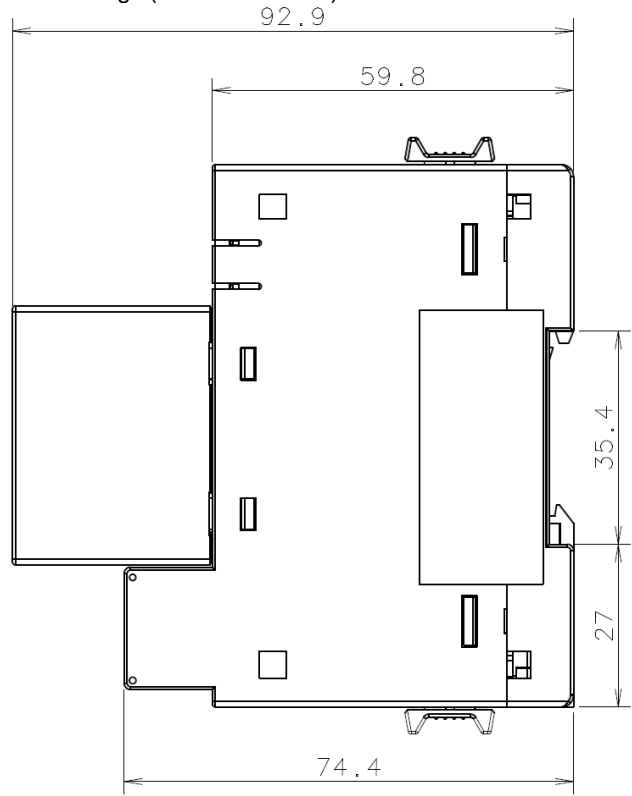
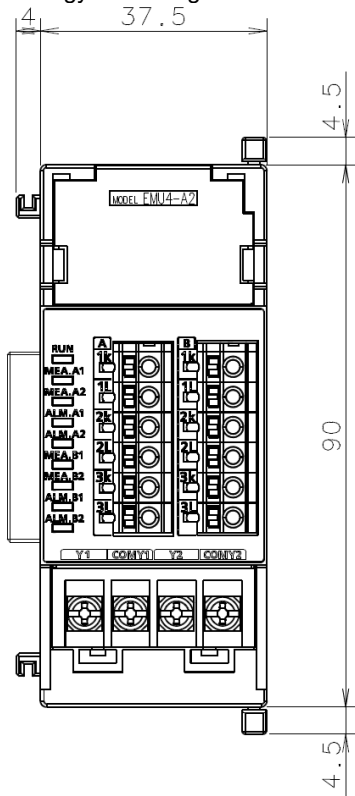

#### ■ Energy Measuring Unit Extension for the systems with the different voltage (Model: EMU4-VA2)

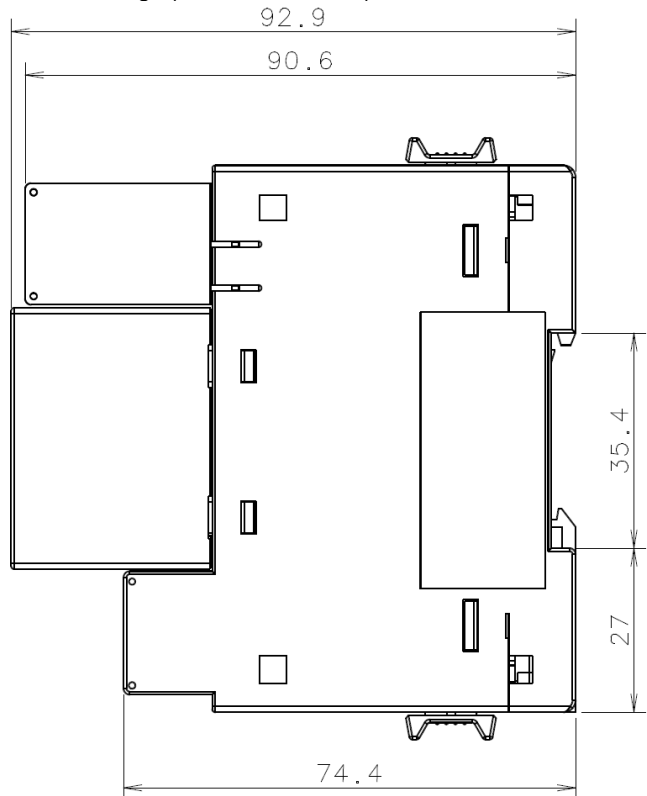
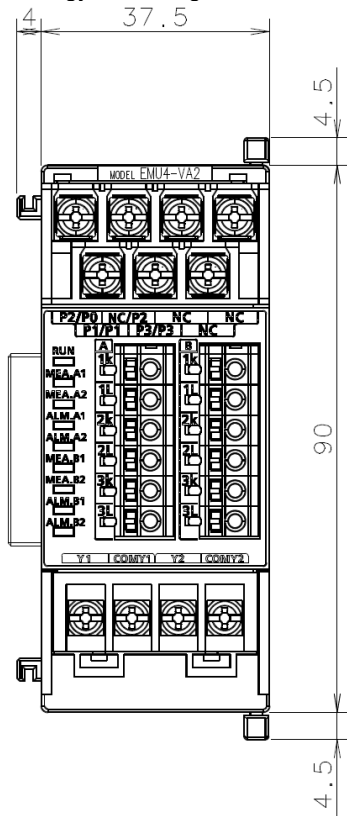

■Energy Measuring Unit Energy Measuring Extension Model for Pulse Input (Model: EMU4-PX4)

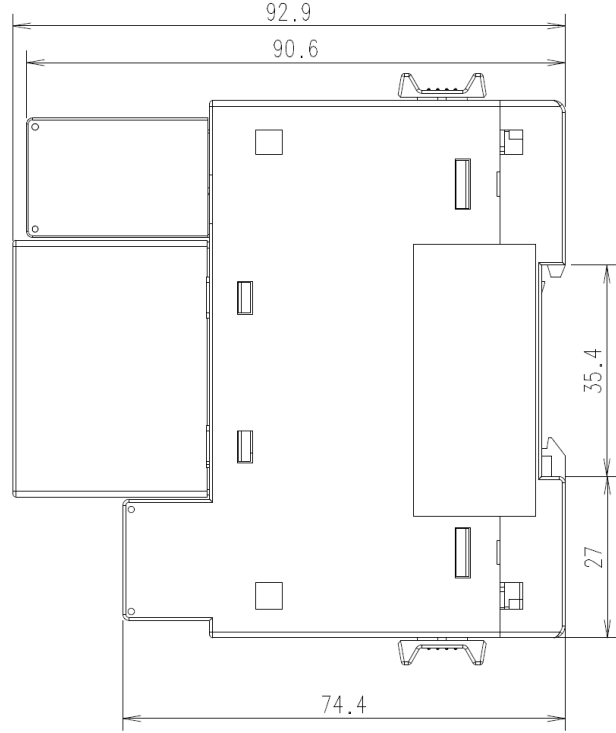
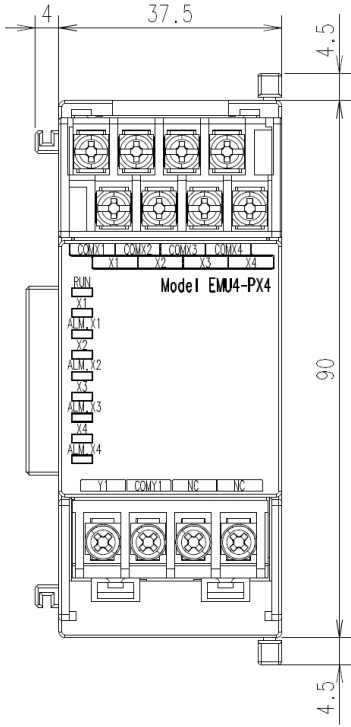

■Energy Measuring Unit Energy Measuring Extension Model for Analog Input (Model: EMU4-AX4)

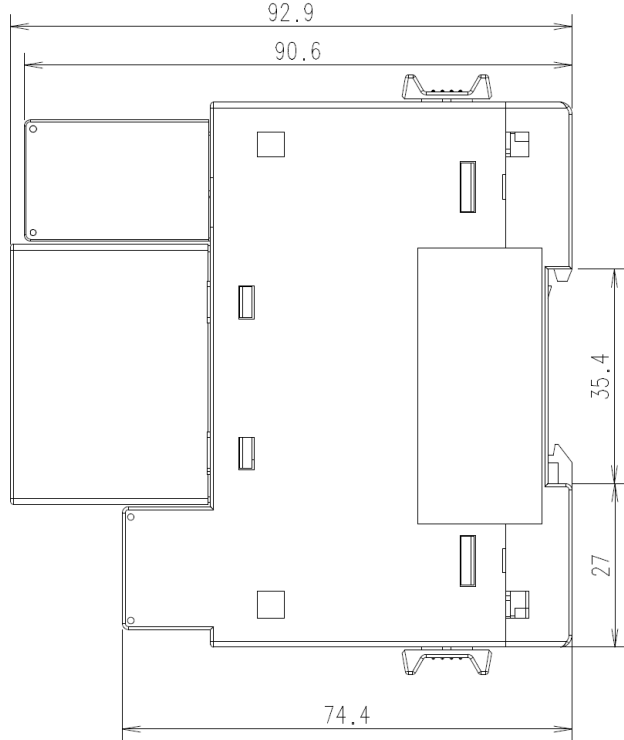
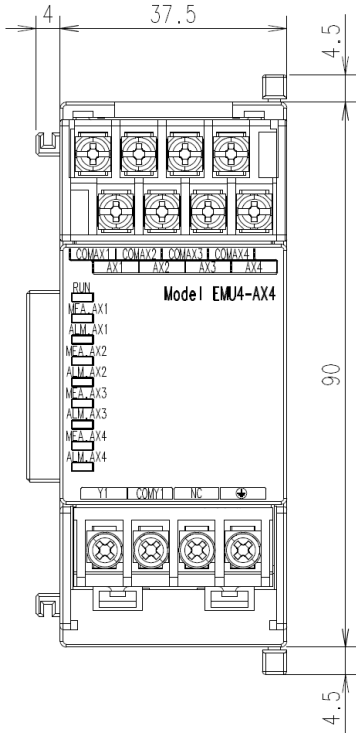

■ CC-Link Communication unit(Model: EMU4-CM-C) for Energy Measuring Unit

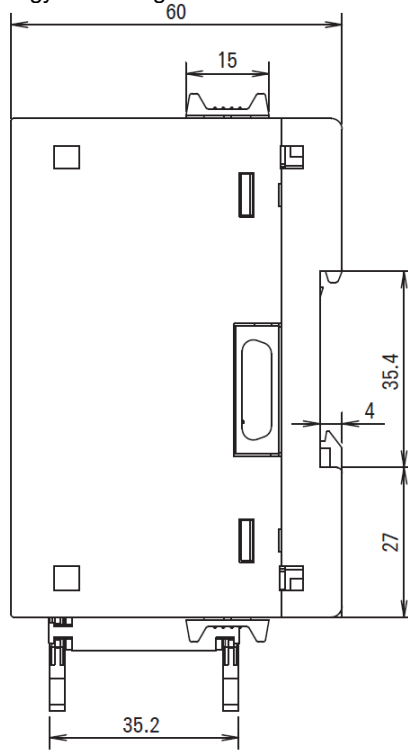
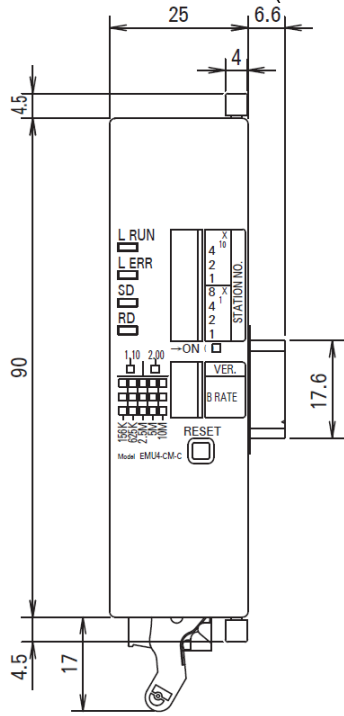

■ Logging Unit(Model: EMU4-LM) for Energy Measuring Unit

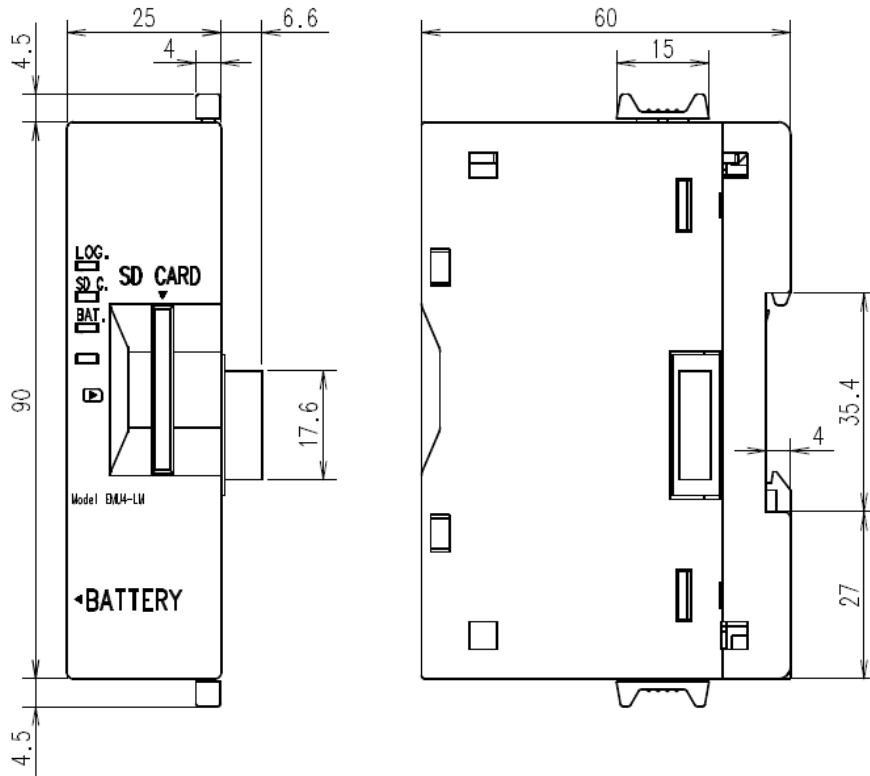

■ CC-Link IE Field NetWork Basic Communication unit (EMU4-CM-CIFB)

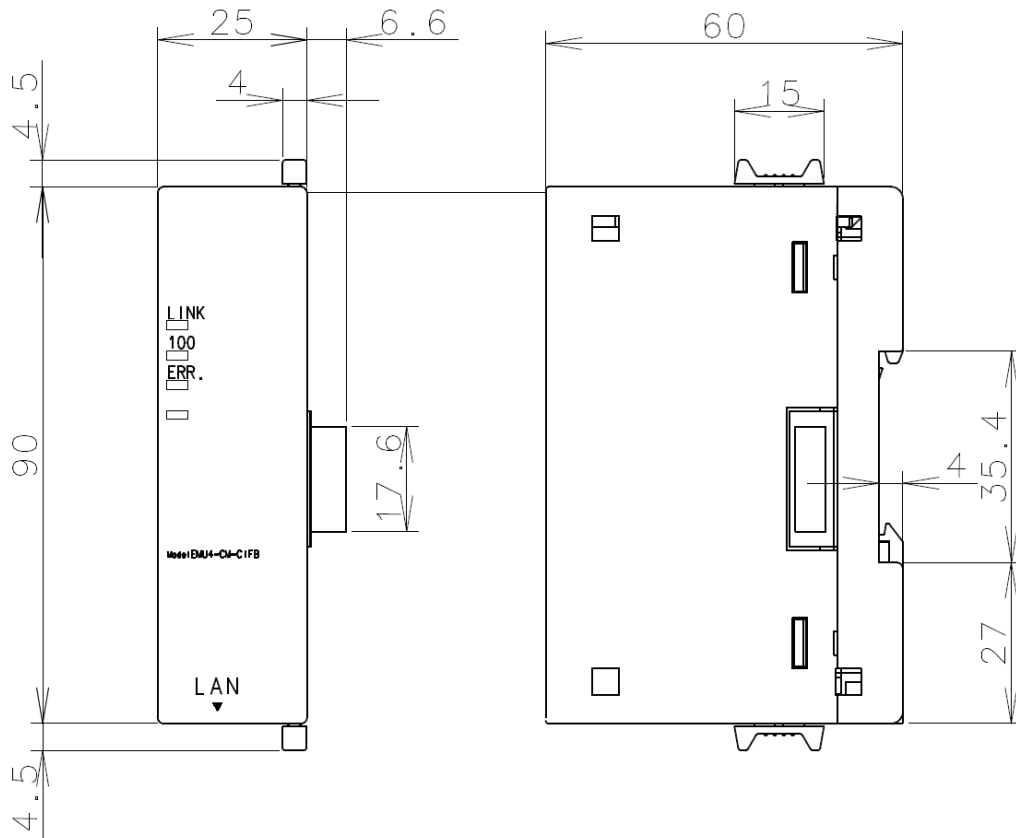

- Small-size display unit(Model: EMU4-D65) for Energy Measuring Unit

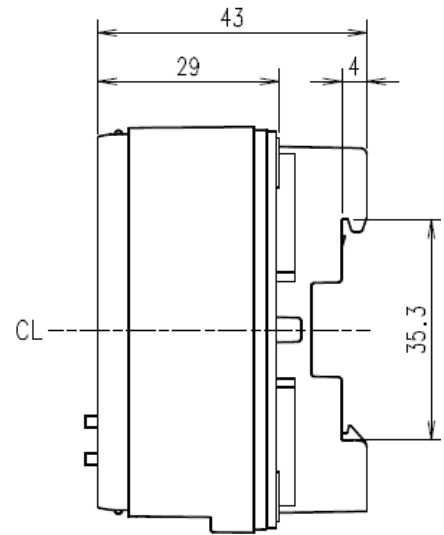
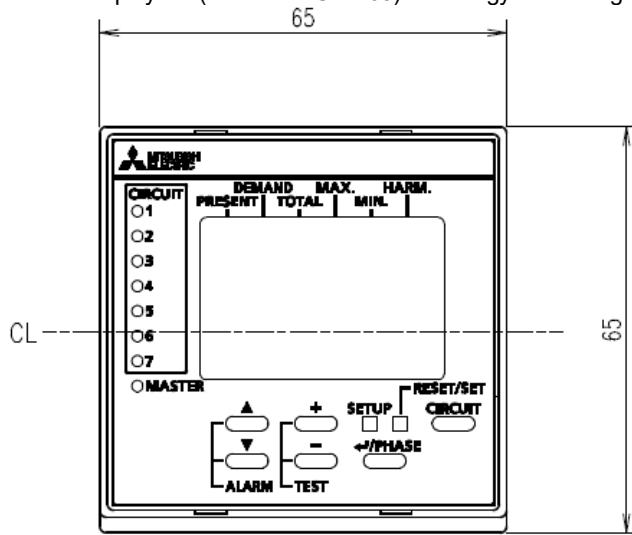

■ Split type current sensor EMU-CT50, EMU-CT100, EMU-CT250 ■ Split type current sensor EMU-CT400, EMU-CT600

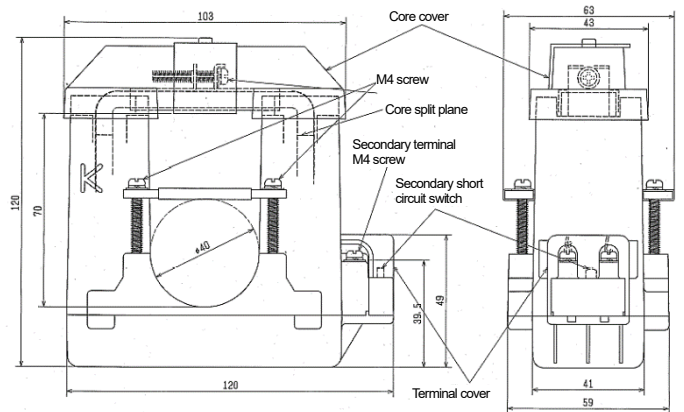
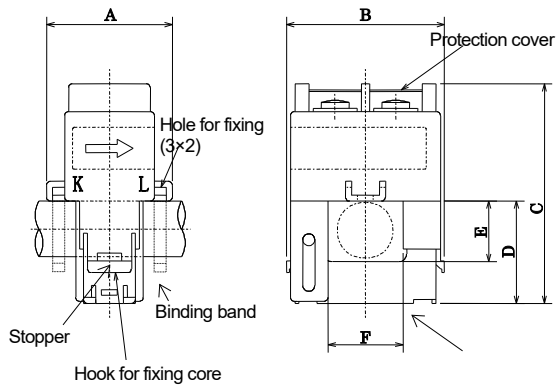

Model	A	B	C	D	E	F
EMU-CT50/CT100	31.5	39.6	55.2	25.7	15.2	18.8
EMU-CT250	36.5	44.8	66.0	32.5	22.0	2

Unit: mm

Unit: mm

■ Split type current sensor (EMU-CT5-A, EMU-CT50-A, EMU-CT100-A)

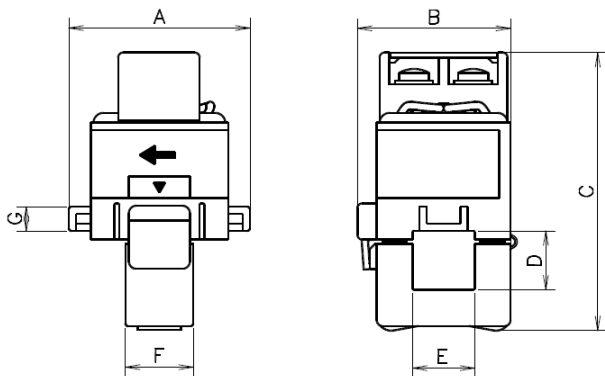

■ Split type current sensor (EMU-CT250-A, EMU-CT400-A, EMU-CT600-A)

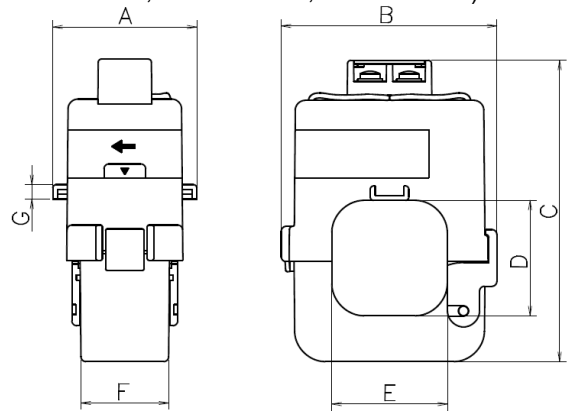

Model	A	B	C	D	E	F	G
EMU-CT50-A	37.4	42.3	54.9	12.2	12.8	14	4.5
EMU-CT400-A	44.9	67.2	94	36	36	27	4.5
EMU-CT100-A	43.6	33.6	65	16.2	16.2	19	5

■ Split type 5A current sensor EMU2-CT5

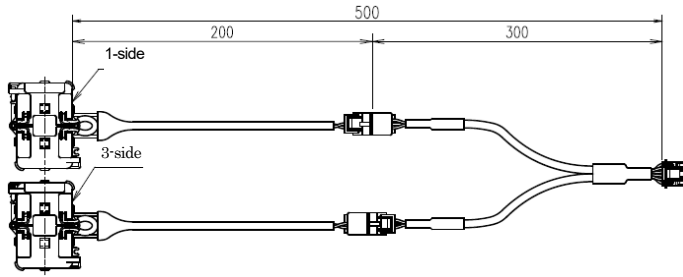

Unit: mm

■ Split type 5A current sensor EMU2-CT5-4W

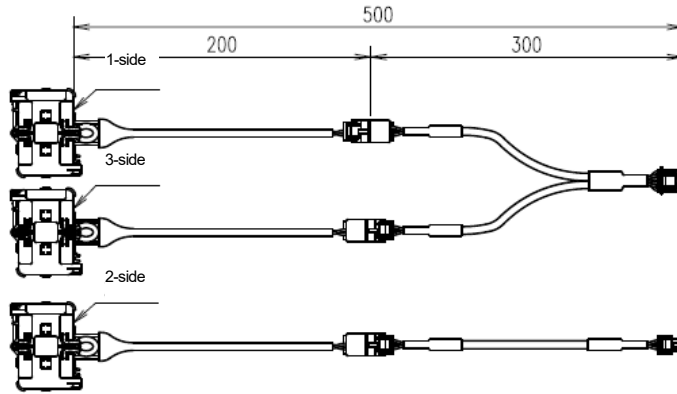

Details for sensor part

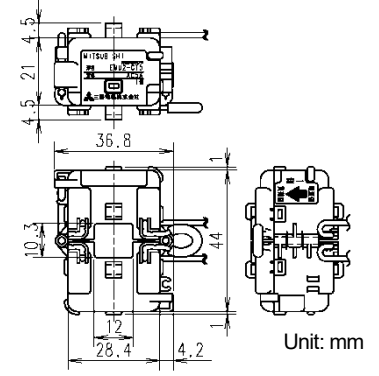

Unit: mm



- Split type 5A current sensor cable EMU2-CB-Q5A

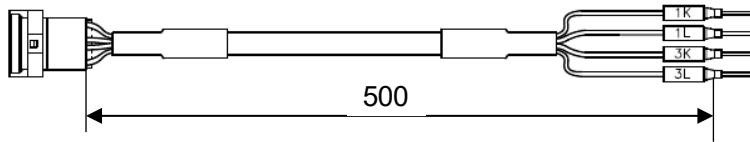

Unit: mm

- Split type 5A current sensor cable EMU2-CB-Q5A-4W

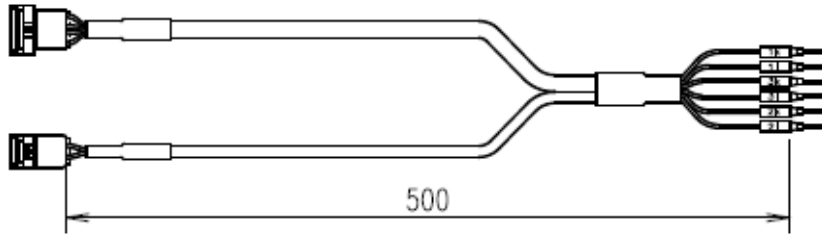

Unit: mm

- Split type 5A current sensor extension cable (standard type) EMU2-CB-T\*\*M

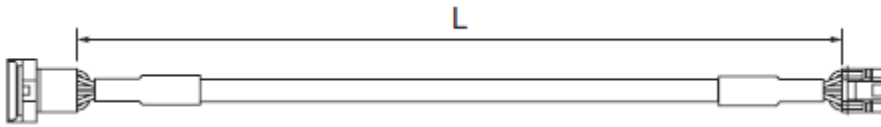

Model	EMU2-CB-T1M	EMU2-CB-T5M	EMU2-CB-T10M
L Size	1m	5m	10m

- Split type 5A current sensor extension cable (separate type) EMU2-CB-T\*\*MS

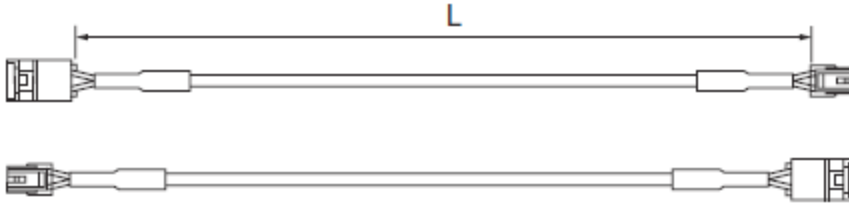

Model	EMU2-CB-T1MS	EMU2-CB-T5MS	EMU2-CB-T10MS
L Size	1m	5m	10m

### 13. External dimensions

Unit: mm

■Model : EMU4-BM1-MB

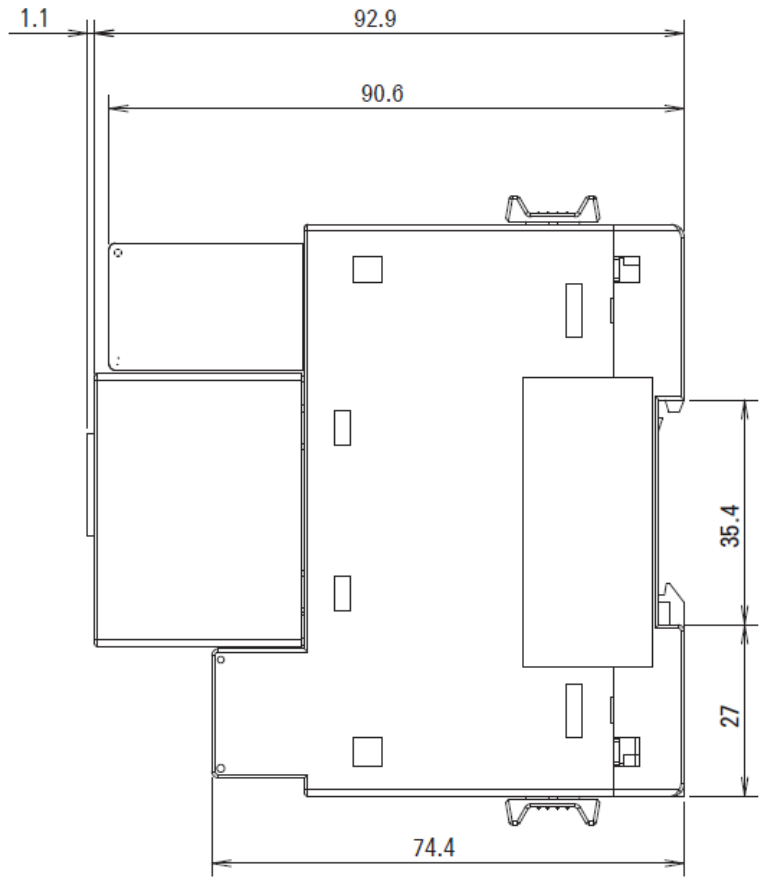
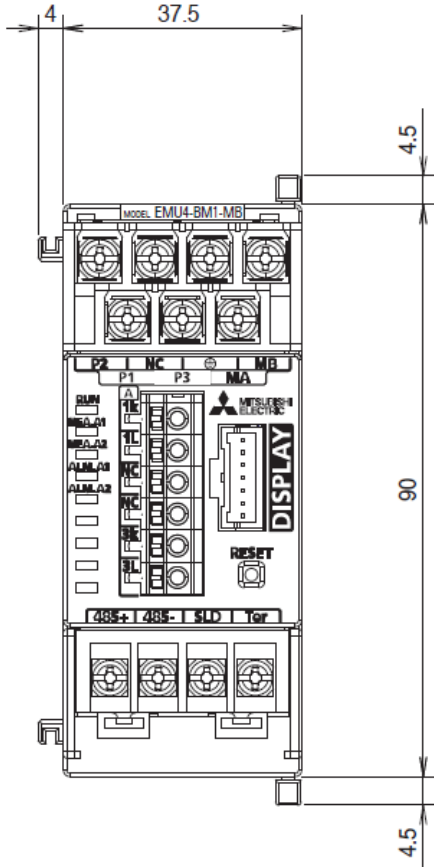

■Model : EMU4-HM1-MB

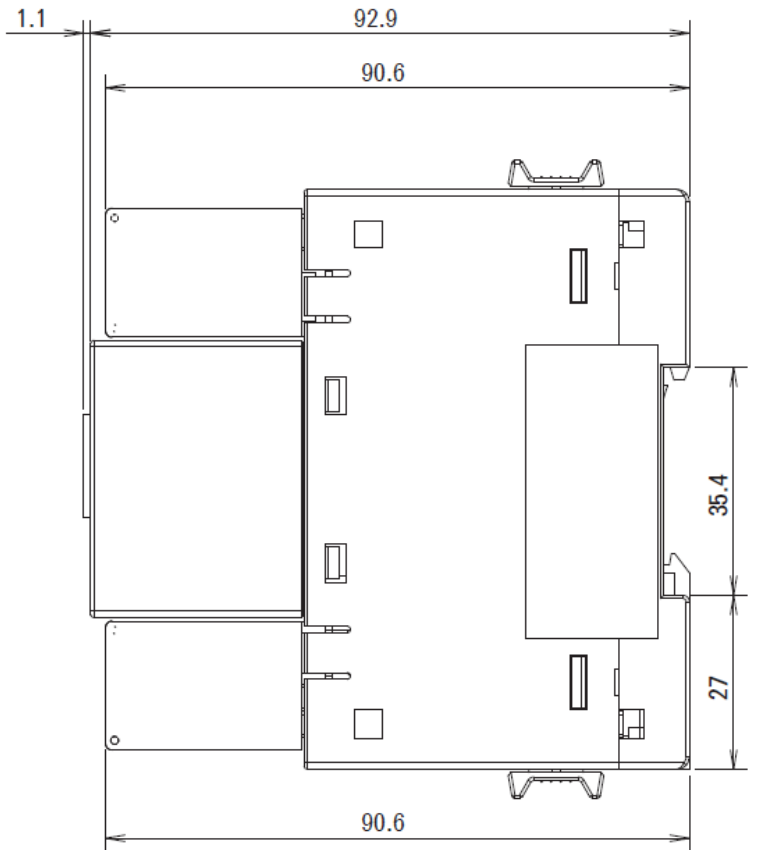
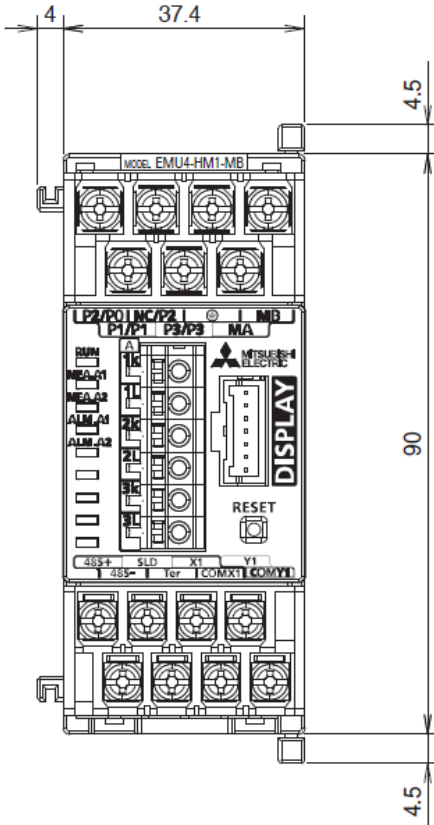

<b>[A]</b>		<b>[N]</b>	
After-sales service.....	39	Name and function of each part .....	5
Alarm reset method.....	30	<b>[O]</b>	
Attaching.....	7	Option devices .....	46
<b>[C]</b>		<b>[P]</b>	
Connection of external input / external output.....	15	Precautions for Operating Environment and Conditions .....	3
Connection of terminal block .....	3	Precautions for Use.....	3
<b>[D]</b>		Primary voltage .....	18
Demand time .....	20	Primary current.....	19
Device operation .....	36	<b>[Q]</b>	
Disclaimer .....	5	Q&A.....	39
Disposal precautions.....	4	<b>[R]</b>	
<b>[E]</b>		Resolution .....	36
External dimensions.....	57	<b>[S]</b>	
<b>[I]</b>		Sensor type.....	19
IEC rail .....	7	Setting.....	18
Initialization.....	23	Specification .....	43
Installation and Wiring Precautions.....	3	Common specifications .....	43
<b>[M]</b>		MODBUS specification.....	45
Maintenance Precautions.....	4	Option devices.....	47
Matters concerning the precaution before use.....	3	Storage Precautions.....	4
Measuring function.....	25	<b>[W]</b>	
MODBUS communication connection.....	15	Wiring.....	8
Monitoring function.....	29	Wiring type .....	18

# Energy Measuring Unit Energy Measuring Standard Model

# Energy Measuring Unit Energy Measuring High Performance Model

## Service Network

Country/Region	Corporation Name	Address	Telephone
Australia	Mitsubishi Electric Australia Pty. Ltd.	348 Victoria Road, Rydalmere, N.S.W. 2116, Australia	+61-2-9684-7777
Algeria	Mec Casa	Rue I N 125 Hay-Es-Salem, 02000, W-Chief, Algeria	+213-27798069
Bangladesh	PROGRESSIVE TRADING CORPORATION	HAQUE TOWER,2ND FLOOR,610/11,JUBILEE ROAD, CHITTAGONG, BANGLADESH	+880-31-624307
	ELECTRO MECH AUTOMATION & ENGINEERING LTD.	SHATABDI CENTER, 12TH FLOOR, SUITES : 12-B, 292, INNER CIRCULAR ROAD, FAKIRA POOL, MOTIJHEEL, DHAKA-1000, BANGLADESH	+88-02-7192826
Belarus	Tehnikon	Oktyabrskaya 19, Off. 705, BY-220030 Minsk, Belarus	+375 (0)17 / 210 46 26
Belgium	Koning & Hartman B.V.	Woluweelaan 31, BE-1800 Vilvoorde, Belgium	+32 (0)2 / 2570240
Brazil	Mitsubishi Electric do Brasil Comércio e Serviços Ltda.	Avenida Adelino Cardana, 293 – 21º Andar, Bethaville, Barueri, SP, Brasil, CEP 06401-147	+55-11-4689-3000
Cambodia	DHINIMEX CO.,LTD	#245, St. Tep Phan, Phnom Penh, Cambodia	+855-23-997-725
Central America	Automation International LLC	7050 W. Palmetto Park Road Suite #15 PMB #555, Boca Raton, FL 33433	+1-561-237-5228
Chile	Rhona S.A. (Main office)	Vte. Agua Santa 4211 Casilla 30-D (P.O. Box) Vina del Mar, Chile	+56-32-2-320-600
China	Mitsubishi Electric Automation (China) Ltd.	Mitsubishi Electric Automation Building, No.1386 Hongqiao Road, Shanghai, China 200336	+86-21-2322-3030
	Mitsubishi Electric Automation (China) Ltd. BeiJing	5/F,ONE INDIGO,20 JiuXianqiao Road Chaoyang District,Beijing, China 100016	+86-10-6518-8830
	Mitsubishi Electric Automation (China) Ltd. ShenZhen	Level 8, Galaxy World Tower B, 1 Yabao Road, Longgang District, Shenzhen, China 518129	+86-755-2399-8272
	Mitsubishi Electric Automation (China) Ltd. GuangZhou	Rm.1006, A1 Times E-Park, No.276-282, Hanxi Road East, Zhongcun Street, Panyu Distric, Guangzhou, China 510030	+86-20-8923-6730
	Mitsubishi Electric Automation (China) Ltd. ChengDu	1501-1503,15F, Guang-hua Centre Building-C, No.98 North Guang Hua 3th Rd Chengdu, China 610000	+86-28-8446-8030
	Mitsubishi Electric Automation (Hong Kong) Ltd.	20/F., Cityplaza One, 1111 King's Road, Taikoo shing, Hong Kong	+852-2510-0555
Colombia	Proelectrico Representaciones S.A.	Carrera 42 No 75 – 367 Bodega 109, Itagüí, Medellín, Antioquia, Colombia	+57-4-4441284
Czech Republic	AUTOCONT CONTROL SYSTEMS S.R.O	Technologická 374/6, CZ-708 00 Ostrava - Pustkovec	+420 595 691 150
Denmark	BEIJER ELECTRONICS A/S	LYKKEGÅRDSVEJ 17, DK-4000 ROSKILDE, Denmark	+45 (0)46 75 76 66
Egypt	Cairo Electrical Group	9, Rostoum St. Garden City P.O. Box 165-11516 Maglis El-Shaab,Cairo - Egypt	+20-2-27961337
France	Mitsubishi Electric Europe B.V. French Branch	FR-92741 Nanterre Cedex	+33 (0)1 55 68 57 01
Germany	Mitsubishi Electric Europe B.V.	Mitsubishi-Electric-Platz 1, 40882 Ratingen, Germany	+49 (0) 2102 4860
Greece	KALAMARAKIS - SAPOUNAS S.A.	IONIAS & NEROMILOU STR., CHAMOMILOUS ACHARNES, ATHENS, 13678 Greece	+30-2102 406000
	UTECO	5, MAVROGENOUS STR., 18542 PIRAEUS, Greece	+30-211-1206-900
Hungary	Meltrade Ltd.	Fertő utca 14. HU-1107 Budapest, Hungary	+36 (0)1-431-9726
India	Mitsubishi Electric India Private Limited	2nd Floor, Tower A&B, Cyber Greens, DLF Cyber City, DLF Phase-III, Gurgaon - 122 022 Haryana, India	+91-124-4630300
	Mitsubishi Electric India Private Limited Pune Sales Office	ICC-Devi Gaurav Technology Park, Unit no. 402, Fourth Floor, Survey no. 191-192 (P), Opp. Vallabh Nagar Bus Depot, Pune – 411018, Maharashtra, India	+91-20-68192100
	Mitsubishi Electric India Private Limited FA Center	204-209, 2nd Floor, 31FIVE, Corporate Road, Prahladnagar, Ahmedabad 380015,Gujarat, India	+91-79677-77888
Indonesia	PT.Mitsubishi Electric Indonesia	Gedung Jaya 8th floor, J.L.MH. Thamrin No.12 Jakarta Pusat 10340, Indonesia	+62-21-3192-6461
	P.T. Sahabat Indonesia	P.O.Box 5045 Kawasan Industri Perqudangan, Jakarta, Indonesia	+62-(0)21-6610651-9
Ireland	Mitsubishi Electric Europe B.V.	Westgate Business Park, Ballymount, IRL-Dublin 24, Ireland	+353 (0)1-4198800
Israel	Gino Industries Ltd.	26, Ophir Street IL-32235 Haifa, Israel	+972 (0)4-867-0656
Italy	Mitsubishi Electric Europe B.V.	Viale Colleoni 7, I-20041 Agrate Brianza (MI), Italy	+39 039-60531
Kazakhstan	Kazpromavtomatika	Ul. Zhambyla 28, KAZ - 100017 Karaganda	+7-7212-501000
Korea	Mitsubishi Electric Automation Korea Co., Ltd	9F Gangseo Hangang xi-tower A, 401 Yangcheon-ro, Gangseo-gu, Seoul 07528 Korea	+82-2-3660-9573
Laos	AROUNKIT CORPORATION IMPORT-EXPORT SOLE CO.,LTD	SAPHANMO VILLAGE. SAYSETHA DISTRICT, VIENTIANE CAPITAL, LAOS	+856-20-415899
Lebanon	Comptoir d'Electricite Generale-Liban	Cebaco Center - Block A Autostrade Dora, P.O. Box 11-2597 Beirut - Lebanon	+961-1-240445
Lithuania	Rifas UAB	Tinklu 29A, LT-5300 Panevezys, Lithuania	+370 (0)45-582-728
Malaysia	Mitrich Sdn Bhd	No. 5 Jalan Pemberita U1/49, Temasya Industrial Park, Glenmarie 40150 Shah Alam,Selangor, Malaysia	+603-5569-3748
	Flexible Automation System Sdn Bhd	60, Jalan USJ 10/1B,UEP Subang Jaya,47620 Selangor Darul Ehsan,Malaysia	+603-5633-1280
Malta	ALFATRADE LTD	99 PAOLA HILL, PAOLA PLA 1702, Malta	+356 (0)21-697-816
Marocco	SCHIELE MAROC	KM 7.2 NOUVELLE ROUTE DE RABAT AIN SEBAA, 20600 Casablanca, Marocco	+212 661 45 15 96
Myanmar	Peace Myanmar Electric Co.,Ltd.	NO137/139 Botahtaung Pagoda Road, Botahtaung Town Ship 11161, Yangon, Myanmar	+95-(0)1-202589
Nepal	Watt&Volt House	KHA 2-65, Volt House Dillibazar Post Box:2108,Kathmandu,Nepal	+977-1-4411330
Netherlands	Imtech Marine & Offshore B.V.	Sluisjesdijk 155, NL-3087 AG Rotterdam, Netherlands	+31 (0)10-487-19 11
North America	Mitsubishi Electric Automation, Inc.	500 Corporate Woods Parkway, Vernon Hills, IL 60061 USA	+847-478-2100
Norway	Scaelec AS	Leirvikasen 43B, NO-5179 Godvik, Norway	+47 (0)55-506000
Mexico	Mitsubishi Electric Automation, Inc. Mexico Branch	Bldv. Miguel de Cervantes Saavedra 301, Torre Norte Piso 5, Col. Ampliación Granada, Miguel Hidalgo, Ciudad de México, CP 11520, México	+52-55-3067-7511
Middle East Arab Countries & Cyprus	Comptoir d'Electricite Generale-International-S.A.L.	Cebaco Center - Block A Autostrade Dora P.O. Box 11-1314 Beirut - Lebanon	+961-1-240430
Pakistan	Prince Electric Co.	2-P GULBERG II, LAHORE, 54600, PAKISTAN	+92-42-575232, 5753373
Peru	Rhona S.A. (Branch office)	Avenida Argentina 2201, Cercado de Lima	+51-1-464-4459
Philippines	MELCO Factory Automation Philippines Inc.	128, Lopez Rizal St., Brgy. Highway Hills, Mandaluyong City, Metro Manila, Philippines	+63-(0)2-256-8042
	Edison Electric Integrated, Inc.	24th Fl. Galleria Corporate Center, Edsa Cr. Ortigas Ave., Quezon City Metro Manila, Philippines	+63-(0)2-634-8691
Poland	Mitsubishi Electric Europe B.V. Polish Branch	Krakowska 48, 32-083 Balice, Poland	+48 12 347 65 00
Republic of Moldova	Intehsis SRL	bld. Traian 23/1, MD-2060 Kishinev, Moldova	+373 (0)22-66-4242
Romania	Sirius Trading & Services SRL	RO-060841 Bucuresti, Sector 6 Aleea Lacul Morii Nr. 3	+40-(0)21-430-40-06
Russia	Mitsubishi Electric (Russia) LLC	2 bld.1, Letnikovskaya street, Moscow, 115114, Russia	+7 495 721-2070
Saudi Arabia	Center of Electrical Goods	Al-Shuwayer St. Side way of Salahuddin Al-Ayoubi St. P.O. Box 15955 Riyadh 11454 - Saudi Arabia	+966-1-4770149
Singapore	Mitsubishi Electric Asia Pte. Ltd.	307 Alexandra Road, Mitsubishi Electric Building, Singapore 159943	+65-6473-2308
Slovakia	PROCONT, Presov	Kupelna 17, SK - 08001 Presov, Slovakia	+421 (0)51 - 7580 611
	SIMAP	Jana Derku 1671, SK - 91101 Trenčín, Slovakia	+421 (0)32 743 04 72
Slovenia	Inea RBT d.o.o.	Stegne 11, SI-1000 Ljubljana, Slovenia	+386 (0)1-513-8116
South Africa	CBI-electric: low voltage	Private Bag 2016, ZA-1600 Isando Gauteng, South Africa	+27-(0)11-9282000
Spain	Mitsubishi Electric Europe B.V. Spanish Branch	Carretera de Rubi 76-80, E-08190 Sant Cugat del Vallés (Barcelona), Spain	+34 (0)93-565-3131
Sweden	Mitsubishi Electric Europe B.V. (Scandinavia)	Hedvig Möllers gata 6, 223 55 Lund, Sweden	+46 (0)8-625-10-00
	Euro Energy Components AB	Järnvägsgatan 36, S-434 24 Kungälv, Sweden	+46 (0)300-690040
Switzerland	TriElec AG	Muehlentalstrasse 136, CH-8201 Schaffhausen, Switzerland	+41-(0)52-6258425
Taiwan	Setস্যু Enterprise Co., Ltd	5th Fl., No.105, Wu Kung 3rd, Wu-Ku Hsiang, Taipei, Taiwan, R.O.C.	+886-(0)2-2298-8889
	United Trading & Import Co., Ltd.	77/12 Bamrungmuang Road.Klong Mahanak Pomprab Bangkok Thailand	+66-223-4220-3
Thailand	MITSUBISHI ELECTRIC FACTORY AUTOMATION (THAILAND) CO.,LTD	101, True Digital Park Office, 5th Floor, Sukhumvit Road, Bangchak, Phara Khanong, Bangkok, 10260 Thailand	+662-092-8600
Tunisia	MOTRA Electric	3, Résidence Imen, Avenue des Martyrs Mourouj III, 2074 - El Mourouj III Ben Arous, Tunisia	+216-71 474 599
Turkey	Mitsubishi Electric Turkey A.Ş.	Şerifali Mahallesi Kale Sokak No: 41, 34775 Ümraniye, Istanbul, Turkey	+90-216-969-2666
United Kingdom	Mitsubishi Electric Europe B.V.	Travellers Lane, UK-Hatfield, Herts. AL10 8XB, United Kingdom	+44 (0)1707-276100
Uruguay	Fierro Vignoli S.A.	Avda. Uruguay 1274 Montevideo Uruguay	+598-2-902-0808
Vietnam	Mitsubishi Electric Vietnam Co.,Ltd. Head Office	11th & 12th Floor, Viettel Tower B, 285 Cach Mang Thang 8 Street, Ward 12, District 10, Ho Chi Minh City, Vietnam	+84-28-3910-5945
	Mitsubishi Electric Vietnam Co.,Ltd. Hanoi Branch	24th Floor, Handico Tower, Pham Hung Road, khu do thi moi Me Tri Ha, Nam Tu Liem District, Hanoi City, Vietnam	+84-24-3937-8075

**MITSUBISHI ELECTRIC CORPORATION**  
HEAD OFFICE: TOKYO BUILDING, 2-7-3, MARUNOUCHI, CHIYODA-KU, TOKYO 100-8310, JAPAN