



# QuickStick 150 User Manual

Catalog Numbers

MMI-QS-S10E10, MMI-QS-S10E05, MMI-QS-S10E03



**Allen-Bradley**

by ROCKWELL AUTOMATION

User Manual

Original Instructions

## Important User Information

Read this document and the documents listed in the additional resources section about installation, configuration, and operation of this equipment before you install, configure, operate, or maintain this product. Users are required to familiarize themselves with installation and wiring instructions in addition to requirements of all applicable codes, laws, and standards.

Activities including installation, adjustments, putting into service, use, assembly, disassembly, and maintenance are required to be carried out by suitably trained personnel in accordance with applicable code of practice.

If this equipment is used in a manner not specified by the manufacturer, the protection provided by the equipment may be impaired.

In no event will Rockwell Automation, Inc. be responsible or liable for indirect or consequential damages resulting from the use or application of this equipment.

The examples and diagrams in this manual are included solely for illustrative purposes. Because of the many variables and requirements associated with any particular installation, Rockwell Automation, Inc. cannot assume responsibility or liability for actual use based on the examples and diagrams.

No patent liability is assumed by Rockwell Automation, Inc. with respect to use of information, circuits, equipment, or software described in this manual.

Reproduction of the contents of this manual, in whole or in part, without written permission of Rockwell Automation, Inc., is prohibited.

Throughout this manual, when necessary, we use notes to make you aware of safety considerations.



**ATTENTION:** Identifies information about practices or circumstances that can lead to personal injury or death, property damage, or economic loss. Attentions help you identify a hazard, avoid a hazard, and recognize the consequence.

---

**IMPORTANT** Identifies information that is critical for successful application and understanding of the product.

---

The following icon may appear in the text of this document.



Identifies information that is useful and can help to make a process easier to do or easier to understand.



Rockwell Automation recognizes that some of the terms that are currently used in our industry and in this publication are not in alignment with the movement toward inclusive language in technology. We are proactively collaborating with industry peers to find alternatives to such terms and making changes to our products and content. Please excuse the use of such terms in our content while we implement these changes.

## Additional Safety Information

Although every effort is made to keep this manual accurate and up-to-date, MagneMotion® and Rockwell Automation® assumes no responsibility for any errors, omissions, or inaccuracies. Information that is provided in this manual is subject to change without notice. Any sample code that is referenced in this manual or included with MagneMotion software is included for illustration only and is, therefore, unsupported.



**ATTENTION:** For additional safety notices and definitions, see the [Notes, Safety Notices, and Symbols](#) section and/or the [Symbol Identification](#) section.

---

## Preface

About This Publication .....	7
Prerequisites .....	7
Appropriate Use .....	7
Notes, Safety Notices, and Symbols .....	7
Notes .....	7
Safety Notices .....	8
Safety Considerations .....	8
Personnel Safety Guidelines .....	8
Equipment Safety Guidelines .....	9
Symbol Identification .....	10
Mechanical Hazards .....	11
Electrical Hazards .....	12
Magnetic Hazards .....	13
Handling Magnet Arrays .....	13
Additional Resources .....	15

## Chapter 1

### QuickStick 150 Transport System Overview

Transport System Components .....	18
Motors .....	19
Magnet Array .....	21
Static Brushes .....	22
Vehicles .....	22
Switches .....	23
Paths .....	23
Guideways .....	24
Motor Controllers .....	24
Nodes .....	24
Node Controllers .....	25
Additional Components .....	26
Electrical Wiring .....	27
Transport System Software Overview .....	28
Getting Started with the QuickStick 150 Transport System .....	29

## Chapter 2

### Component Specifications and Identification

QuickStick 150 Transport System Hazard Locations .....	31
QuickStick 150 Motors .....	32
Catalog Number Explanation for Motors .....	32
Motor Label Identification and Location .....	32
Motor Dimensions .....	33
QuickStick 150 Power Cables .....	36
Catalog Number Explanation for Cables .....	36
QuickStick Magnet Array .....	36
Catalog Number Explanation for Magnet Arrays .....	37
Mechanical Specifications .....	37
Magnet Array Label and Identification .....	38

<b>Motor Connections</b>	<b>Chapter 3</b>	
	Motor Electrical Connections.....	41
	Motor Ethernet Connections .....	44
<b>Installation</b>	<b>Chapter 4</b>	
	Required Tools and Materials .....	47
	Unpacking and Inspection.....	47
	Unpacking and Moving Instructions .....	48
	QuickStick 150 Motor and Magnet Array Installation.....	49
	Install Motor Mounts .....	49
	Mounting the Motors.....	52
	Magnet Array Installation.....	54
	Connecting Motors and Electronics .....	58
	Facilities Connections .....	63
	Check-out and Power-up.....	63
	System Check-out.....	63
	System Power-up .....	64
	Software.....	66
	Motor Software Installation .....	67
	System Testing .....	67
	Vehicle Installation.....	68
<b>Operation</b>	<b>Chapter 5</b>	
	Motion Control.....	75
	Motor Topology .....	75
	Motor Operation .....	76
	Motor Cogging.....	76
	Motor Blocks .....	77
	Block Acquisition.....	77
	Block Ownership .....	78
	Block Release .....	78
	Anti-Collision.....	78
	Safe Stopping Distance .....	79
	Thrust Limitations .....	79
	Automatic Vehicle Queue.....	80
	Vehicle Length Through Curves and Switches .....	81
	Locating Vehicles During Startup.....	81
	Electrical System .....	81
	Power Regenerated by a Vehicle.....	82
	Power Management Within the QS 150 Motor.....	82
	Soft Start .....	82
	Block Level Power Management .....	83
	Node Controllers.....	84
	Controls and Indicators.....	84
	Track Display.....	84
	FastStop.....	85
	Transport System Operation.....	85
	Power-up .....	85

	Normal Running .....	86
	Safe Shut-down .....	86
	<b>Chapter 6</b>	
<b>Maintenance</b>	Preventive Maintenance .....	87
	Cleaning .....	87
	Spray Cleaning .....	88
	Wear Surface Maintenance .....	88
	Cable Connection Inspection .....	89
	Hardware Inspection .....	89
	Cleaning Magnet Arrays .....	89
	Motor Replacement .....	89
	Replacing Motors .....	90
	Programming Replaced Motors .....	91
	Ordering Parts .....	92
	Shipping .....	92
		<b>Chapter 7</b>
<b>Troubleshooting</b>	Initial Troubleshooting .....	95
	Power-Related Troubleshooting .....	95
	Power Related Warnings and Faults .....	97
	Power Related Fault Resolution .....	98
	Node Controller Troubleshooting .....	99
	Communication Troubleshooting .....	99
	Motion Control Troubleshooting .....	100
Fault Light Troubleshooting .....	101	
	<b>Index</b> .....	103

**Notes:**

## About This Publication

This manual explains how to install, operate, and maintain the QuickStick® 150 (QS 150) transport system. This manual also provides information about basic troubleshooting.

Use this manual in combination with the other manuals and documentation that accompanies the transport system to design, install, configure, test, and operate a QS 150 transport system. Rockwell Automation offers instructor-led or on-line training classes that provide additional instruction in the installation, configuration, testing, and operation of a QS 150 transport system.

## Prerequisites

The information and procedures that are provided in this manual assume the following:

- Basic familiarity with general-purpose computers and with the Windows® operating system, web browsers, and terminal emulators.
- Complete design specifications, including the physical layout of the transport system, are available.
- All personnel who configure, operate, or service the transport system are properly trained.

## Appropriate Use

Read and understand the safety instructions before using the QuickStick 150 system and review [Motor Label Identification and Location on page 32](#).



**ATTENTION:** Incorrect use of the products can cause personal injury and property damage.

- Hardware must remain in its original state; never make structural changes.
- Do not de-compile software or alter source codes.
- Do not use damaged or faulty components.
- Install the system in the manner that is described in this manual.
- Operate the system in the ambient conditions that are described in the QuickStick Motors Technical Data, publication [MMI-TD051](#).

## Notes, Safety Notices, and Symbols

Notes, Safety Notices, and Symbols that are used in this manual have specific meanings and formats. Examples of notes, the different types of safety notices and their general meanings are provided in this section. Adhere to all safety notices provided throughout this manual to achieve safe installation and use.

## Notes

Notes are set apart from other text and provide additional or explanatory information as shown in the following example:









A note provides additional or explanatory information that is useful and can help to make a process easier to do or easier to understand.

## Safety Notices

Safety Notices are set apart from other text. The color of the panel at the top of the notice and the text in the panel indicates the severity of the hazard. The symbol on the left of the notice identifies the type of hazard see [Symbol Identification on page 10](#) for symbol descriptions. The text in the message panel identifies the hazard, methods to avoid the hazard, and the consequences of not avoiding the hazard.

Examples of the standard safety notices that are used in this manual are provided in this section. Each example includes a description of the hazard level indicated.

	<div style="background-color: red; color: white; padding: 5px; text-align: center;">  <b>DANGER</b> </div> <p><i>Danger</i> indicates a hazardous situation which, if not avoided, will result in death or serious injury.</p>
	<div style="background-color: orange; padding: 5px; text-align: center;">  <b>WARNING</b> </div> <p><i>Warning</i> indicates a hazardous situation which, if not avoided, could result in death or serious injury.</p>
	<div style="background-color: yellow; padding: 5px; text-align: center;">  <b>CAUTION</b> </div> <p><i>Caution</i> indicates a hazardous situation, which if not avoided, could result in minor or moderate injury.</p>

---

**IMPORTANT** Identifies information that is critical for successful application and understanding of the product.

---

## Safety Considerations



These safety recommendations are basic guidelines. Any additional safety guidelines and applicable local and national safety codes for the facility must be followed

### Personnel Safety Guidelines

QuickStick 150 components and transport systems can provide several direct safety hazards to personnel if not properly installed or operated. General safety guidelines are provided in this section, specific cautions are provided as needed. See [Mechanical Hazards on page 11](#), [Electrical Hazards on page 12](#), and [Magnetic Hazards on page 13](#) for additional information.

- Personnel operating or servicing the QS 150 transport system must be properly trained.
- Be aware of the hazardous points of the QS 150 transport system as described in this manual.
- High-strength neodymium iron boron magnet arrays are used on vehicles with the QS 150 motors.
  - To avoid severe injury, people with pacemakers and other medical electronic implants must not handle or approach the magnet arrays. These individuals must consult their physician to determine the



- susceptibility of their device to static magnetic fields and to determine a safe distance between themselves and the magnet array.
- Handle only one vehicle/magnet array at a time. Do not place any body parts, such as fingers, between a magnet array and any QS 150 motors, ferrous material, or another magnet array to avoid injury from strong magnetic attractive forces.
- Vehicles and magnet arrays not on the QS 150 transport system must be secured individually in isolated packaging.
- Moving mechanisms have no obstruction sensors and can cause personal injury.
- Whenever power is applied, the possibility of automatic motion of the vehicles or user-supplied equipment in the QS 150 transport system exists. It is the responsibility of the user to provide appropriate safeguards.
- Make sure that propulsion power is disabled whenever maintenance is being performed on the vehicles, track system, or motors.
- Make sure that the QS 150 motors and related components are properly decontaminated before performing any service. Follow the decontamination procedures at the facility.
- Follow all facility, local, and national procedures for the disposal of any hazardous materials or waste.

## Equipment Safety Guidelines





The following safety considerations are provided to aid in the placement and use of the QuickStick 150 transport system.

- The QS 150 components are not provided with an Emergency Off (EMO) circuit. The facility where the system is installed is responsible for an EMO circuit.
- Do not place the power and communication cables for the QS 150 transport system where they could cause a trip hazard.
- Do not place the QS 150 transport system in a location where it could be subject to physical damage.
- Make sure that all electrical connections to the QS 150 components are made in accordance with the appropriate facility, local, and national regulations.
- Make sure that the QS 150 components receive proper airflow for cooling.
- Do not remove safety labels or equipment identification labels.
- Turn off power before inserting or removing the power cables.
- Use of the QS 150 components for any purpose other than as a linear transport system is not recommended and can damage the QS 150 components or the equipment they are connected to.
- Always operate the QS 150 transport system with appropriate barriers in place to help prevent contact with moving objects by personnel.
- Do not install or operate the QS 150 transport system if any of the components have been dropped, damaged, or are malfunctioning.
- Keep cables and connectors away from heated surfaces.
- Do not modify the connectors or ports.



## Symbol Identification

Symbols are used in this manual and on the products to identify hazards, mandatory actions, and prohibited actions. The symbols that are used in this manual and their descriptions are provided in the following tables.



**Table 1 - Hazard Alert Symbol Identification**

Symbol	Description
	<b>General Hazard Alert</b> - Indicates that failure to follow recommended procedures can result in unsafe conditions, which could cause injury or equipment damage.
	<b>Lifting Hazard</b> - Indicates that the specified object is heavy or awkward to handle. Personnel must use lifting aids and proper techniques for lifting to avoid muscle strain or back injury.
	<b>Automatic Start Hazard</b> - Indicates the possibility of machinery automatically starting or moving, which could cause personal injury.
	<b>Hazardous Voltage</b> - Indicates that a severe shock hazard is present that could cause personal injury.
	<b>Magnetic Field Hazard</b> - Indicates that a strong magnetic field is present that could cause personal injury.
	<b>Pinch/Crush Hazard</b> - Indicates that there are exposed parts that move, which could cause personal injury from the squeezing or compression of fingers, hands, or other body parts between those parts.

**Table 2 - Mandatory Action Symbol Identification**

Symbol	Description
	<b>Eye Protection Required</b> - Indicates that appropriate eyewear must be worn to help prevent injury to eyes from flying shards.
	<b>Foot Protection Required</b> - Indicates that appropriate footwear must be worn to help prevent injury to feet from falling objects.
	<b>Lockout Required</b> - Indicates that all power must be disconnected using a method that helps prevent accidental reconnection.





**Table 3 - Prohibited Action Symbol Identification**





Symbol	Description
	<b>Magnetic or Electronic Media Prohibited</b> - Indicates that magnetic media (memory disks/chips, credit cards, tapes, and so on) is not allowed in the specified area due to the possibility of damage to the media.
	<b>Metal Parts or Watches Prohibited</b> - Indicates that watches, instruments, electronics, metal tools, and metal objects are not allowed in the specified area due to the possibility of damage.
	<b>Pacemakers or Medical Implants Prohibited</b> - Indicates that persons with medical implants are not allowed in the specified area due to the possibility of personal injury.

## Mechanical Hazards

The QuickStick 150 transport system is a complex electromechanical system. Only personnel with the proper training should install, operate, or service the QS 150 transport system.





All facilities to the QS 150 transport system must be disconnected as outlined in the lockout/tag-out procedure for the facility before servicing to help prevent injury from the automatic operation of the equipment. The proper precautions for operating and servicing remotely controlled electromechanical equipment must be observed. These precautions include wearing safety glasses, safety shoes, and any other precautions that are specified within the facility where the QS 150 components are being used.

	 <b>WARNING</b>
	<p style="text-align: center;"><b>Crush Hazard</b></p> <p>Moving mechanisms have no obstruction sensors. Do not operate the QuickStick 150 components without barriers in place or personal injury could result in the squeezing or compression of fingers, hands, or other body parts between moving mechanisms.</p>
	 <b>WARNING</b>
	<p style="text-align: center;"><b>Automatic Movement Hazard</b></p> <p>Whenever power is applied, the possibility of automatic movement of the vehicles on the QuickStick 150 transport system exists, which could result in personal injury.</p>

	 <b>CAUTION</b>
	<p style="text-align: center;"><b>Loose Material Hazard</b></p> <p>Payloads are susceptible to vector motion forces. Always account for the effects of acceleration, deceleration, and directional changes upon the payload. Control forces to avoid projectile motion of the payload, limit move profiles and/or provide tooling to secure the payload to the vehicle.</p>
 	 <b>CAUTION</b>
	<p style="text-align: center;"><b>Lift Hazard</b></p> <p>The QuickStick 150 motors can weigh as much as 15.42 kg (34 lb). Failure to take the proper precautions before moving them could result in personal injury. Use proper techniques for lifting and wear safety toe shoes when moving any QuickStick 150 components.</p>

## Electrical Hazards

The user-supplied power supplies, node controllers, network switches, and power modules are connected to the main incoming facility power and can generate hazardous energy. The proper precautions for operating and servicing electrical equipment must be observed. These precautions include following facility lockout/tag-out procedures, and any other specified action within the facility where the QS 150 components are being used.

 	 <b>WARNING</b>
	<p style="text-align: center;"><b>Electrical Hazard</b></p> <p>All electrical power to the QuickStick 150 transport system must be disconnected per the facility lockout/tag-out procedure before servicing to help prevent the risk of electrical shock.</p>
	 <b>CAUTION</b>
	<p style="text-align: center;"><b>Electrical Hazard</b></p> <p>To avoid electric shock, do not open any QuickStick 150 component. Motors, controllers, and other components do not contain any user-serviceable parts. Do not turn on electrical power to the power supplies, motors, and node controllers until after connecting all other transport system components.</p>













To avoid equipment damage:

- Make sure that the entire transport system, including motors, controllers, vehicles, power supplies, and switches are properly grounded.
- Make sure that all vehicles are grounded to the guideway through conductive wheels or static brushes.
- Do not connect or disconnect any components while the transport system has power.

## Magnetic Hazards

The QuickStick 150 transport system uses high strength neodymium iron boron (NdFeB) magnets in the magnet arrays that get attached to the vehicles. The proper precautions for using high strength magnets must be observed.

 	<p style="text-align: center;"> <b>WARNING</b></p> <p style="text-align: center;"><b>Magnetic Field Hazard</b></p> <p>The mover uses strong magnets.</p> <p>There is a risk of health hazard for people with heart pacemakers, metal implants, hearing aids, and other medical electronic implants while in proximity of magnetic and magnetic-field producing components. The magnetic field that is generated can disrupt the functionality of automatic-implantable cardioverter defibrillator (AICD). People with cardiac pacemakers must stay away from the magnet arrays.</p>
 	<p style="text-align: center;"> <b>WARNING</b></p> <p style="text-align: center;"><b>Crush Hazard</b></p> <p>Strong magnets in use.</p> <p>To avoid severe injury:</p> <ul style="list-style-type: none"> <li>• Handle only one vehicle or magnet array at a time.</li> <li>• Do not place any body parts (for example, fingers) between a magnet array and any QuickStick 150 motors, ferrous material, or another magnet array to avoid injury from strong magnetic attractive forces.</li> <li>• Vehicles and magnet arrays not being used must be secured individually in isolated packaging.</li> </ul>
  	<p style="text-align: center;"> <b>CAUTION</b></p> <p style="text-align: center;"><b>Magnetic Fields</b></p> <p>Strong magnets in use.</p> <p>To avoid damage to watches, electronic instruments, and magnetic media (for example, cell phones, memory disks/chips, credit cards, and tapes) keep these items away from the magnet arrays.</p>

### Handling Magnet Arrays

- The neodymium iron boron (NdFeB) magnets that are used in the QuickStick magnet arrays require special handling. General handling guidelines and cautions are provided in this section. It is the responsibility of the user to define and implement their own handling guidelines in accordance with the applicable facility, local, and national safety codes for the installation site.
- Pacemakers and other medical implants – Individuals with pacemakers or internal medical devices must use caution when handling the magnet arrays as the magnetic fields can affect the operation of these devices. These individuals must consult their physician and the manufacturer of their medical device to determine

its susceptibility to static magnetic fields before handling the magnet arrays and to determine the safe distance from the arrays, or if they must not handle the arrays.

- **Electronic Equipment Damage** – Do not allow any magnet arrays near sensitive electronics, equipment with cathode ray tubes (CRTs) or other displays, or magnetic storage media (for example, disks, credit cards, cell phones).
- **Pinch/Crush** – The magnet arrays have a high attractive force to each other and ferromagnetic materials like steel, iron, some stainless steels, and nickel and the QuickStick motors. Pinching happens if the magnet arrays are allowed to come together against a body part – usually fingers. Do not try to stop moving objects or magnet arrays that have been attracted to each other.
- **Impact** – Do not strike the magnet arrays as the magnets within them can shatter and break. The magnets within the magnet arrays can spark on impact. Handle carefully in explosive atmospheres.
- **Sharp Fragments** – The magnet arrays are strong and unsecured magnet arrays can accelerate toward other magnets, magnet arrays, or ferromagnetic materials. The magnets in the arrays are brittle, and if allowed to collide, the magnets in the arrays can shatter and break, possibly sending particles flying at high speed.
- **Debris Accumulation** – Protect all magnet arrays in a transport system to help prevent the accumulation of debris. If debris is accumulated, it can get caught between the magnet array and the motor, which affects system performance and can damage the cover of the motor.
- **Corrosion** – The magnets in all QuickStick magnet arrays are protected against corrosion. However, damage (for example, scratches, chips) to the magnet array or the magnets creates the potential for corrosion. NdFeB rare-earth magnets that have corroded have changed their physical properties. The Safety Data Sheets (SDS) for the component materials (iron, neodymium, boron, nickel, and copper) must be consulted before the use, handling, or transportation of corroded magnets.
- **Machining** – Do not drill, grind, machine, or sand the magnets or the magnet arrays. The magnets can shatter or break when drilled or machined. The magnet dust that machining creates is hazardous and can be harmful if inhaled or allowed to get into eyes. Drilling, grinding, and machining can produce metal powder, which is flammable and can ignite and burn at high intensity, which creates toxic fumes. Additionally, machining can cause high heat to develop resulting in demagnetization.
- **Use** – The magnet arrays must never be used to lift any objects. The QuickStick magnet arrays must only be used for propulsion with a QuickStick motor by attaching the array to a vehicle.
- **Storage** – Store magnet arrays in appropriate storage or shipping containers (shielded with steel or isolated). Never leave magnet arrays unattended outside the storage containers. If unshielded magnet arrays must be left unattended, the area must be marked with a magnetic hazard sign in accordance with the applicable facility, local, and national safety codes for the installation site.
- **Handling** – Appropriate handling is required. Handle only one magnet array at a time. If an array is attracted to another object, DO NOT attempt to stop it. Wearing gloves and safety glasses when handling the magnet arrays is recommended. Inspect the area before handling the magnet arrays and make sure it is free of other magnet arrays or ferromagnetic materials.

- Temperature – If the temperature of the magnet arrays gets over approximately 80 °C (176 °F), the magnets begin to lose field strength irreversibly. A maximum operating temperature of 50 °C (122 °F) and maximum storage and shipping temperatures of 60 °C (140 °F) is recommended.
- Signage – Make sure that appropriate cautionary signage is in place in all locations where the magnet arrays are located. Signage must be in accordance with the applicable facility, local, and national safety codes for the installation site.

## Additional Resources

These documents contain additional information related to products from Rockwell Automation. Before you configure or run the QuickStick 150 components, consult the documentation that follows:

You can view or download publications at [rok.auto/literature](http://rok.auto/literature).

Resource	Description
MagneMotion QuickStick and QuickStick HT Design Guide, publication <a href="#">MMI-RM001</a>	This manual explains how to design and configure the track layout and transport system.
MagneMotion System Configurator User Manual, publication <a href="#">MMI-UM046</a>	This manual explains how to use the QuickStick Configurator to create and modify the Node Controller Configuration File (Configuration File) for the transport system.
QuickStick Motors Technical Data, publication <a href="#">MMI-TD051</a>	This manual includes technical specifications for the QuickStick 100 and QuickStick 150 motors.
MagneMotion Node Controller Interface User Manual, publication <a href="#">MMI-UM001</a>	This manual explains how to use the supplied interfaces to configure and administer node controllers that are used with independent cart technology (ICT) transport systems. This manual also provides basic troubleshooting information.
MagneMotion LSM Synchronization Option User Manual, publication <a href="#">MMI-UM005</a>	This manual explains how to install, operate, and maintain the linear synchronous motor (LSM) synchronization option for use with independent cart technology (ICT) transport systems.
MagneMotion NCHost TCP/IP Interface Utility User Manual, publication <a href="#">MMI-UM010</a>	This manual explains how to use the NCHost TCP/IP Interface Utility to run a independent cart technology (ICT) transport system for testing and debugging. This manual also explains how to develop Demo Scripts to automate vehicle motion for that testing.
MagneMotion Virtual Scope Utility User Manual, publication <a href="#">MMI-UM011</a>	This manual explains how to install and use the MagneMotion Virtual Scope utility. This utility provides real-time feedback of the change in linear synchronous motor (LSM) performance parameters.
MagneMotion Node Controller Hardware User Manual, publication <a href="#">MMI-UM013</a>	This manual explains how to install and maintain the node controllers that are used with MagneMover® LITE™ and transport systems.
MagneMotion Host Controller TCP/IP Communication Protocol User Manual, publication <a href="#">MMI-UM003</a>	These manuals describe the communication protocols between the high level controller and a host controller. These manuals also provide basic troubleshooting information.
MagneMotion Host Controller EtherNet/IP Communication Protocol User Manual, publication <a href="#">MMI-UM004</a>	
Power Supply Reference Manual 1606-XLS960F-3, publication <a href="#">1606-RM032</a>	The manual provides the specifications for the 1606 power supplies.
EtherNet/IP Network Devices User Manual, publication <a href="#">ENET-UM006</a>	Describes how to configure and use EtherNet/IP™ devices to communicate on the EtherNet/IP network.
Ethernet Reference Manual, publication <a href="#">ENET-RM002</a>	Describes basic Ethernet concepts, infrastructure components, and infrastructure features.
System Security Design Guidelines Reference Manual, publication <a href="#">SECURE-RM001</a>	Provides guidance on how to conduct security assessments, implement Rockwell Automation products in a secure system, harden the control system, manage user access, and dispose of equipment.
UL Standards Listing for Industrial Control Products, publication <a href="#">CMPNTS-SR002</a>	Assists original equipment manufacturers (OEMs) with construction of panels, to help ensure that they conform to the requirements of Underwriters Laboratories.
American Standards, Configurations, and Ratings: Introduction to Motor Circuit Design, publication <a href="#">IC-AT001</a>	Provides an overview of American motor circuit design based on methods that are outlined in the NEC.
Industrial Components Preventive Maintenance, Enclosures, and Contact Ratings Specifications, publication <a href="#">IC-TD002</a>	Provides a quick reference tool for Allen-Bradley industrial automation controls and assemblies.
Safety Guidelines for the Application, Installation, and Maintenance of Solid-state Control, publication <a href="#">SGI-1.1</a>	Designed to harmonize with NEMA Standards Publication No. ICS 1.1-1987 and provides general guidelines for the application, installation, and maintenance of solid-state control in the form of individual devices or packaged assemblies incorporating solid-state components.
Industrial Automation Wiring and Grounding Guidelines, publication <a href="#">1770-4.1</a>	Provides general guidelines for installing a Rockwell Automation industrial system.
Product Certifications website, <a href="http://rok.auto/certifications">rok.auto/certifications</a>	Provides declarations of conformity, certificates, and other certification details.

**Notes:**



## QuickStick 150 Transport System Overview

The QuickStick® 150 (QS 150) is an intelligent transport system that provides fast, precise motion, and the positioning and tracking of medium loads in a transport system. The QS 150 transport system is a configuration of linear synchronous motors and related control electronics that move independently commanded material carriers (vehicles) in a controlled manner at various acceleration/deceleration and velocity profiles while carrying a wide range of payloads with high precision.

The QS 150 transport system consists of the following components:

- QuickStick 150 motors
- User-designed and supplied vehicles with QuickStick magnet arrays
- Node controllers
- User-supplied power supplies
- User-supplied host controller
- User-designed and supplied guideway and track system

QuickStick 150 motors provide repeatable positioning with no hard stops required, bidirectional travel, smooth motion, and continuous vehicle tracking and reporting.

- Motor, drive, controller, positioning, and guidance are built into the motor.
- Servo repeatability at any position: is  $\pm 0.05$  mm (0.002 in.) (dependent on the size of the gap between the motor and the vehicle-mounted magnet array). Repeatability can vary based on the PID settings that are used, and the track and vehicle design/structure, but the repeatability is not applicable over the gaps between motors.
- Vehicles are controlled individually allowing the host controller to prioritize the routing of individual vehicles over different paths.
- Configuration and simulation software tools simplify transport system design and optimization.
- Designed for use in cleanrooms and IP66/IP67 environments (motors and magnet arrays only).



To ensure IP66/IP67 ratings, tighten cable collars to 11 lb•in (1.24 N•m)

- Less wear and tear – no belts, chains, gears, or external sensors required – fewer moving parts means less maintenance.
- Standard industrial communication protocols, host controller controlled, and software configured move profiles (PID control loop) for fast and easy changeovers to new configurations.
- Standard motor and configuration elements provide plug and play capability and make it easy to implement layout changes.

## Transport System Components

The QuickStick 150 components consist of a set of basic building-blocks that provides an easy to assemble and implement transport system. The modular nature of the QS 150 components makes it easy to implement layout or control changes.

The transport system layout is used to locate the motors and other transport system components in the facility. It is also used as a reference when connecting the components of the transport system and defining the elements of the Node Controller Configuration File, see the MagneMotion® System Configurator User Manual, publication [MMI-UM046](#).

To use the installed transport system, create an application that runs on the host controller. This host application provides all monitoring and control of the transport system.

For additional information on the transport system design, see MagneMotion QuickStick and QuickStick HT Design Guide, publication [MMI-RM001](#).

**Figure 1 - Detailed View of QuickStick 150 Transport System Components**

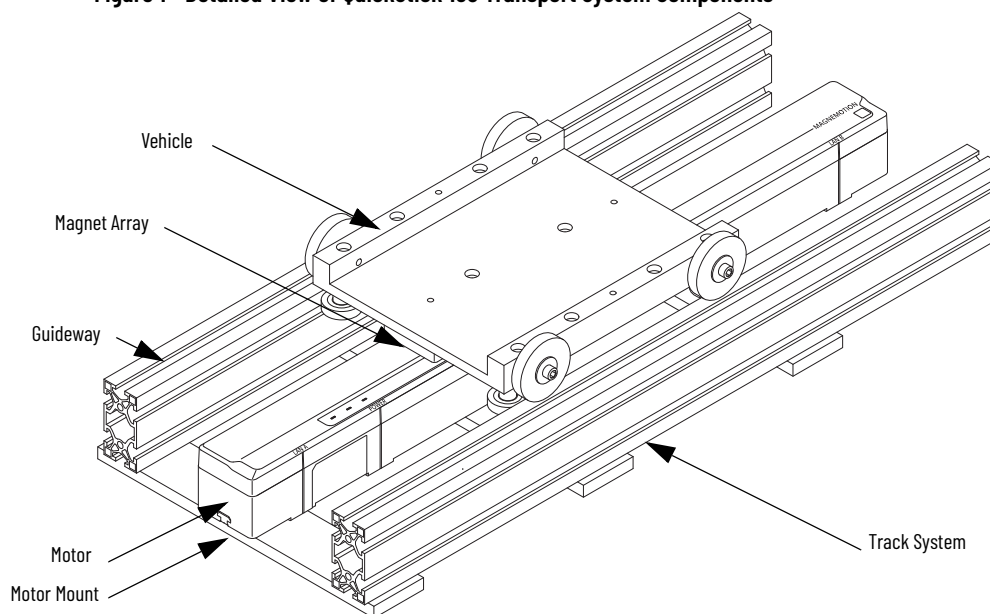

- **Track System** – The components that physically support and move vehicles. The track system includes the support structure, the guideway, one or more QS 150 motors, and mounting hardware.
- **Guideway** – Used to make sure that the vehicles are maintained in the proper relationship to the motors.
  - **Straight and Curve** – Motors placed end-to-end to provide a continuous path of motion.
  - **Switch** – (not shown in [Figure 1](#)) Three motors that are configured to provide either a merge of two paths into one or a diverge from one path into two.
- **Motor** – The QS 150 linear synchronous motor (LSM).
- **Motor Mount** – Used to mount the motor to the guideway.
- **Vehicle with Magnet Array** – Carries the payload through the QS 150 transport system as directed. The magnet array is mounted to the vehicle and interacts with the motors, which moves the vehicle.

Figure 2 - Simplified View of the QuickStick 150 Transport System Components

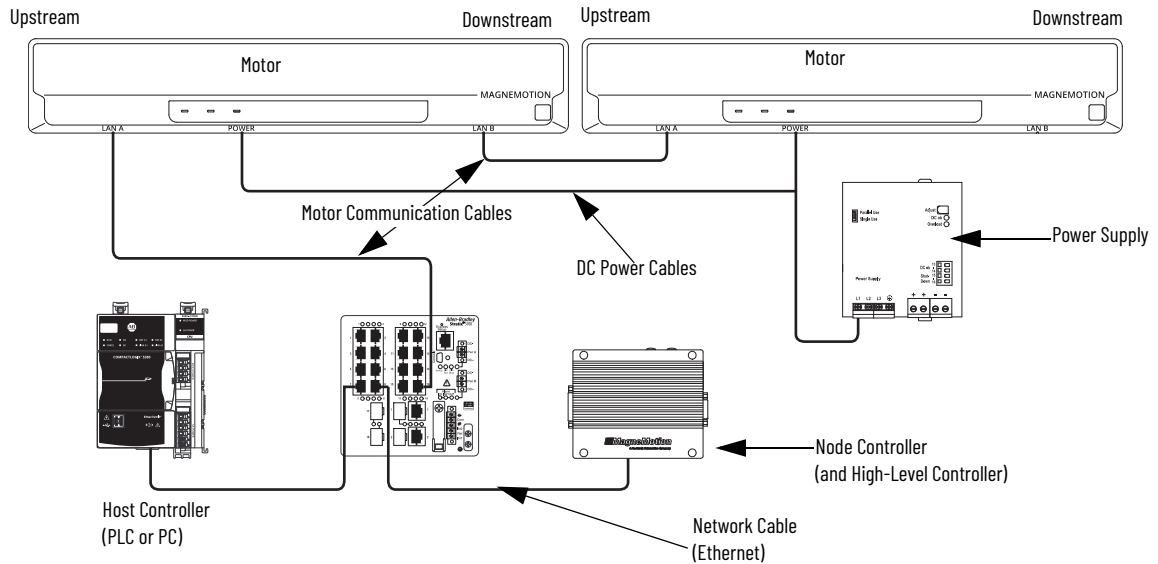

- **DC Power Cables** – Distributes DC power to the motors.
- **Communication Cables** – Provides communications between the components of the transport system.
- **High-Level Controller (HLC)** – Software application that is enabled on one node controller. This application handles all communication with the user-supplied host controller and directs communication to individual node controllers.
- **Host Controller** – Provides user control and monitoring of the QuickStick 150 transport system. This component is user-supplied.
- **Motor** – Refers to the QS 150 linear synchronous motor (LSM).
- **Network** – Ethernet network providing communications (TCP/IP or EtherNet/IP™) between the host controller and the HLC (TCP/IP is used between node controllers).
- **Node Controller (NC)**– Coordinates motor operations and communicates with the HLC. Provides an active network port, digital inputs, and digital outputs.
- **Power Supply** – Provides DC power to the motors.
- **Vehicle with Magnet Array** – Carries a payload through the QS 150 transport system as directed. The magnet array is mounted to the vehicle and interacts with the motors, which move each vehicle independently.

## Motors

The transport system layout is a plan view layout of the QS 150 transport system. This drawing identifies each motor and switching mechanism (if necessary) in the transport system, see [Figure 4 on page 20](#) for an example. The drawing also includes how they are physically located, the space between each motor, and any interfaces to other equipment in the facility. The control software makes sure that the minimum distance between vehicles when not moving is 6 mm (0.24 in.). See [Motor Topology on page 75](#).

The QuickStick 150 motors have a three bi-color light-emitting diode (LED) indicator which specifies power and system health. See [Table 17 on page 66](#) and [Table 25 on page 101](#) for details and descriptions.

Figure 3 - QuickStick 150 System, Single Array Vehicle

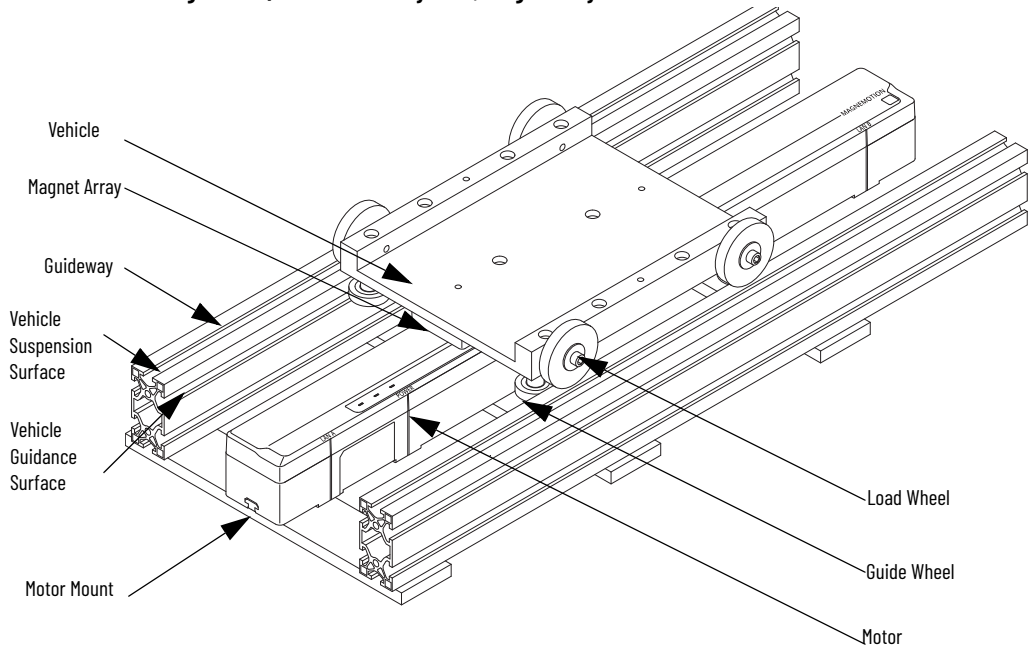

QuickStick 150 motors have a required direction. When using multiple motors, the downstream end of one motor is followed by the upstream end of the next motor in the same path. Forward vehicle motion on the QS 150 motors is from upstream to downstream, however vehicles can move backwards (downstream to upstream) if necessary. See [Figure 2 on page 19](#) and [Figure 51 on page 62](#).

The QS 150 motors can be mounted in any orientation: right side up, sideways, upside down, and vertically. If the motor is mounted on an incline or vertically, the motor does not hold a vehicle in place during startup, restarts, or if power is lost.

Figure 4 - Sample QS 150 Transport System Layout Showing Motors

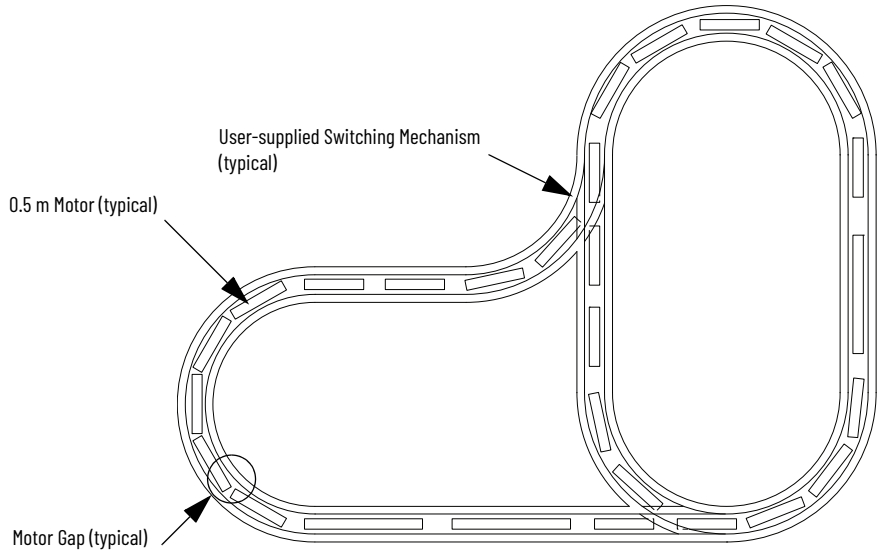

### Additional Motor Requirements

- Accommodations for track length and topology
  - See [Figure 17 ... Figure 19 on page 34](#) for QS 150 mechanical drawings
  - See [Figure 20](#) for QuickStick magnet array mechanical drawings
- The QS 150 transport system allows only one vehicle at a time on a motor block, see [Table 4](#). Each block is a discrete motor primary section of multiple coils within the motor that is energized over its whole length.

**Table 4 - QS 150 Motor Blocks**

Motor Type	Stator Length	Block Length	No. Blocks	Internal Gap <sup>(1)</sup>
QS 150 and QS 100	1 meter	96 mm	10	9 mm
QS 150 and QS 100	0.5 meter	96 mm	5	9 mm
QS 150	0.3 meter	96 mm	3	9 mm

(1) Internal gap is used to calculate downstream motor gap, see [Figure 38 on page 53](#). The internal gap is present on both motors involved in a gap (meaning the upstream internal gap and the downstream internal gap).

## Magnet Array

The standard magnet array for the QS 150 motors is an arrangement of alternating North-oriented and South-oriented neodymium iron boron (NdFeB) permanent magnets placed perpendicular to the direction of motion. Orientation of the magnets is referenced to the surface facing the motor as shown in [Figure 5 on page 22](#).

### Magnet Array Length and Attractive Force

There is a strong magnetic attractive force present between the magnet array and the QS 150 motor. The magnetic attractive force is always present, even if there is no power to the motor.

---

**IMPORTANT** When determining the number of cycles that are required for the magnet array, be sure to account for the downstream gap. See MagneMotion QuickStick and QuickStick HT Design Guide, [MMI-RM001](#) for additional information on downstream gaps and attractive force.

---

### Magnet Array Use

The QuickStick magnet arrays are intended for use as the QS 150 motor secondary as part of the vehicle and must not be used for any other purpose, see [Magnet Array Installation on page 54](#) for additional information.

Protect all magnet arrays on the transport system from debris accumulation. If debris is accumulated, it can get caught between the magnet array and the motor. Any accumulated debris affects the performance and can damage the cover of the motor or the magnet array, see [Cleaning Magnet Arrays on page 89](#) for additional installation precautions and cleaning information.

---

**IMPORTANT** Even though the magnet arrays are covered with a stainless steel cover the magnets can still be damaged and are subject to corrosion if damaged.

---

For additional information on magnet array features, specifications, and dimensions, see QuickStick Motors Technical Data, publication [MMI-TD051](#).

Figure 5 - Standard Magnet Array, 5 Cycles, 11 Poles

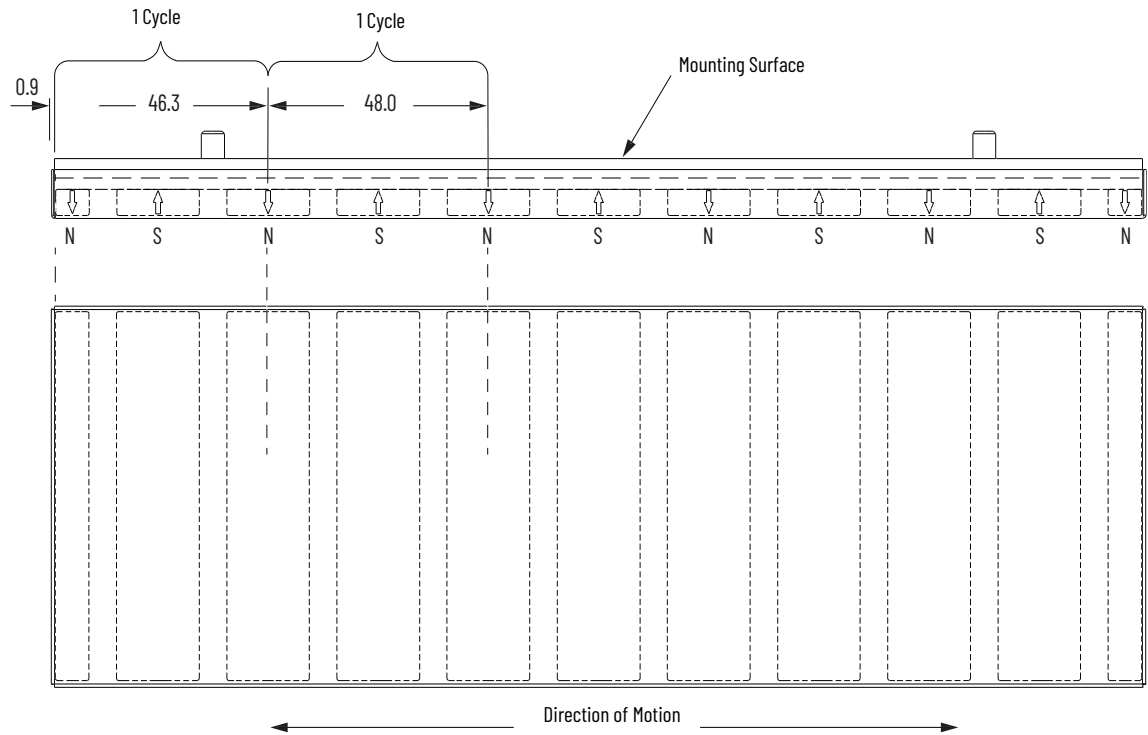

## Static Brushes

A static brush is a conductive brush that is mounted to the vehicle that is preferably in constant contact with the grounded track. The brush can either act as a permanent connection to ground or as a discharge point with a low resistance. This method keeps static from building appreciably, which helps prevent arcing to the motors or track. All parts of the vehicle that can retain a charge must be electrically connected to the brush to help prevent isolated components from building up a charge.



**SHOCK HAZARD:** Vehicles must be grounded to the guideway through conductive materials such as wheels, skids, or static brushes. Make sure that the equipment or track system where the QS motors are mounted and the motor mounting surfaces are properly grounded to safety (earth) ground.

## Vehicles

Vehicles are user-designed independent platforms with integral magnet arrays that are used on QuickStick 150 transport systems. Each vehicle is independently controlled and provides a platform for securing and carrying the payload. Forward vehicle motion is from upstream to downstream, however vehicles can move backwards (downstream to upstream) if necessary.

- Vehicles must be grounded to the guideway through conductive materials such as wheels, skids, or static brushes.
- The vehicle must have low friction with the guideway.
- All vehicles on connected guideways must be the same size and use the same size and type of magnet array.

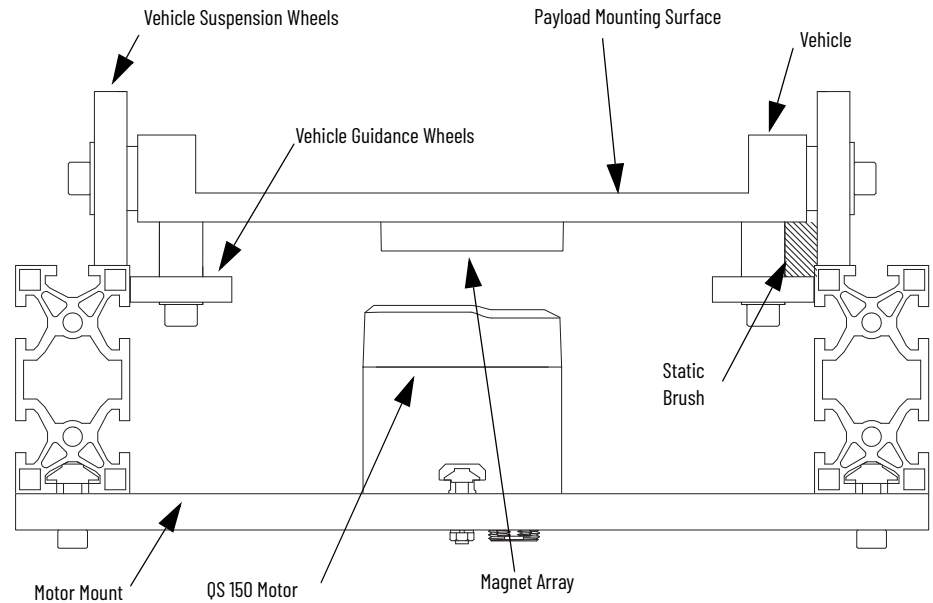
**Figure 6 - Typical Vehicle on Guideway**

## Switches

Switches connect multiple paths and direct the vehicles from one path on the transport system to another path. The switch mechanism is defined and supplied by the user.

## Paths

Paths define the routes for vehicle motion, see [Figure 7](#). All paths include one or more motors arranged end to end. All paths must begin at a node and can end at a second node, depending on the use of the path. Paths are unique and do not overlap. Each path is provided a unique identifier in the Node Controller Configuration File. Each motor is identified as belonging to a specific path and provided a unique identifier in the Node Controller Configuration File. See the MagneMotion System Configurator User Manual, publication [MMI-UM046](#) for a detailed description of paths.

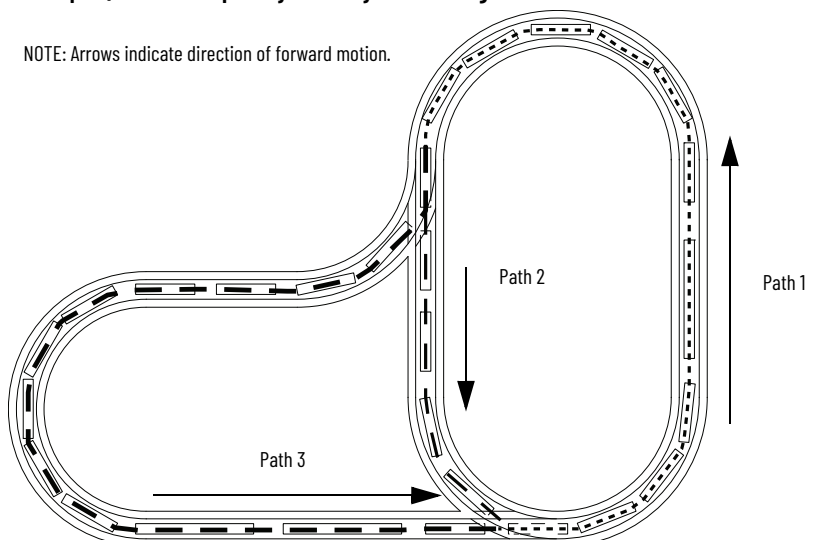
**Figure 7 - Sample QS 150 Transport System Layout Showing Paths**

## Guideways

Vehicle motion imparts dynamic loads on the guideway system. The guideway must be adequately secured to a rigid, permanent structure to help reduce vibrations and other stresses on the system. See MagneMotion QuickStick and QuickStick HT Design Guide, [MMI-RM001](#) for additional information on guideways.



**ATTENTION:** The guideway must be earth grounded and provide a path to ground for ESD discharge from the vehicle. Conductive wheels or static brushes must also be used to dissipate static charge. These elements are installed by the customer and are not included with the motor.

Figure 8 - Guideway Example #1

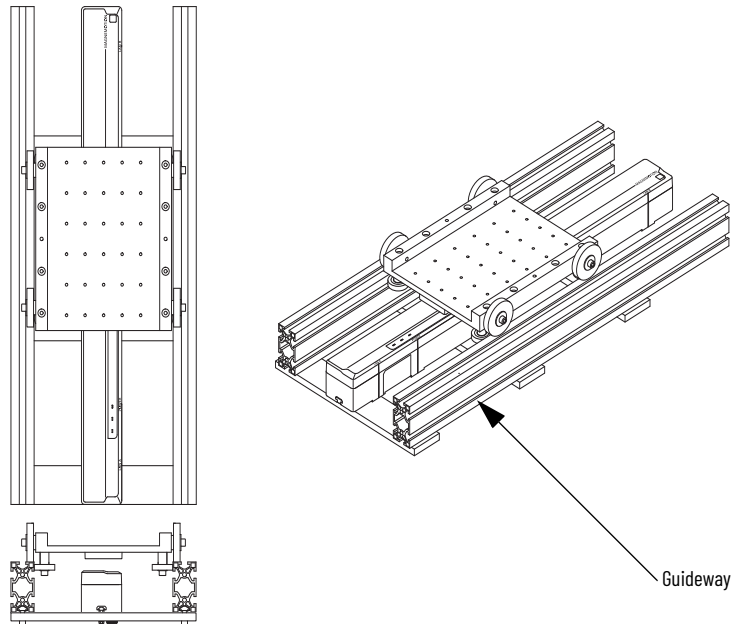

## Motor Controllers

Each QS 150 motor has one motor controller that is located inside the QS 150 motor.

The motor controller is responsible for controlling the thrust that is applied to each vehicle by the motor and reading the sensors in the motor to determine vehicle position. The motor controllers communicate with each other and a node controller via an Ethernet network.

## Nodes

Nodes define the beginning of all paths and the connections between paths, see [Figure 9 on page 25](#). See the MagneMotion System Configurator User Manual, publication [MMI-UM046](#) for a detailed description of nodes and all node types.



The connections to the motors at the ends of all paths that meet in a node must be made to the same node controller.



**Figure 9 - Sample QS 150 Transport System Layout Showing Nodes**

NOTE: Arrows indicate direction of forward motion.

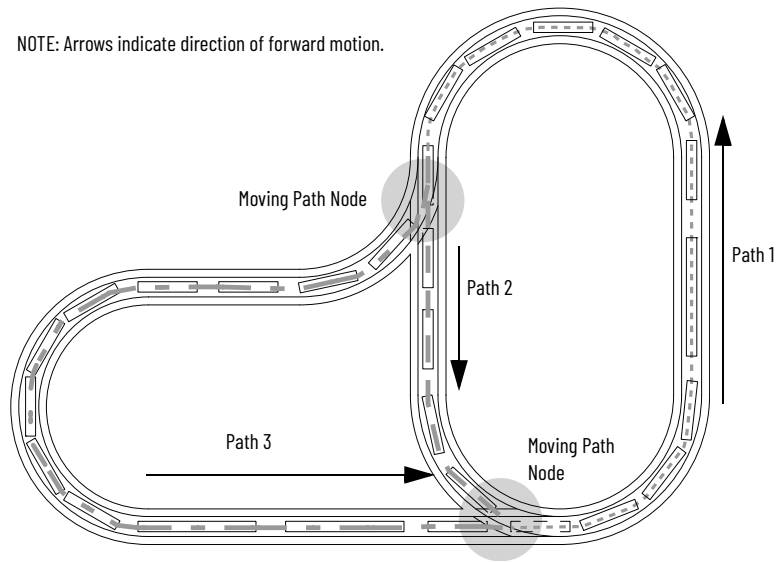

### Node Controllers

Node controllers coordinate all motor operations and communicate with the high-level controller (HLC), see [Figure 10](#). In all QS 150 transport systems, one node controller is designated as the HLC. The HLC manages the communication between all node controllers in the transport system and the host controller.

For more information on node controllers, see MagneMotion Node Controller Hardware User Manual, publication [MMI-UM013](#) and MagneMotion Node Controller Interface User Manual, publication [MMI-UM001](#).



All motor connections at a node must be made to the same node controller.

**Figure 10 - Example QS 150 Transport System Layout Showing Node Controllers**

NOTE: Arrows indicate direction of forward motion.

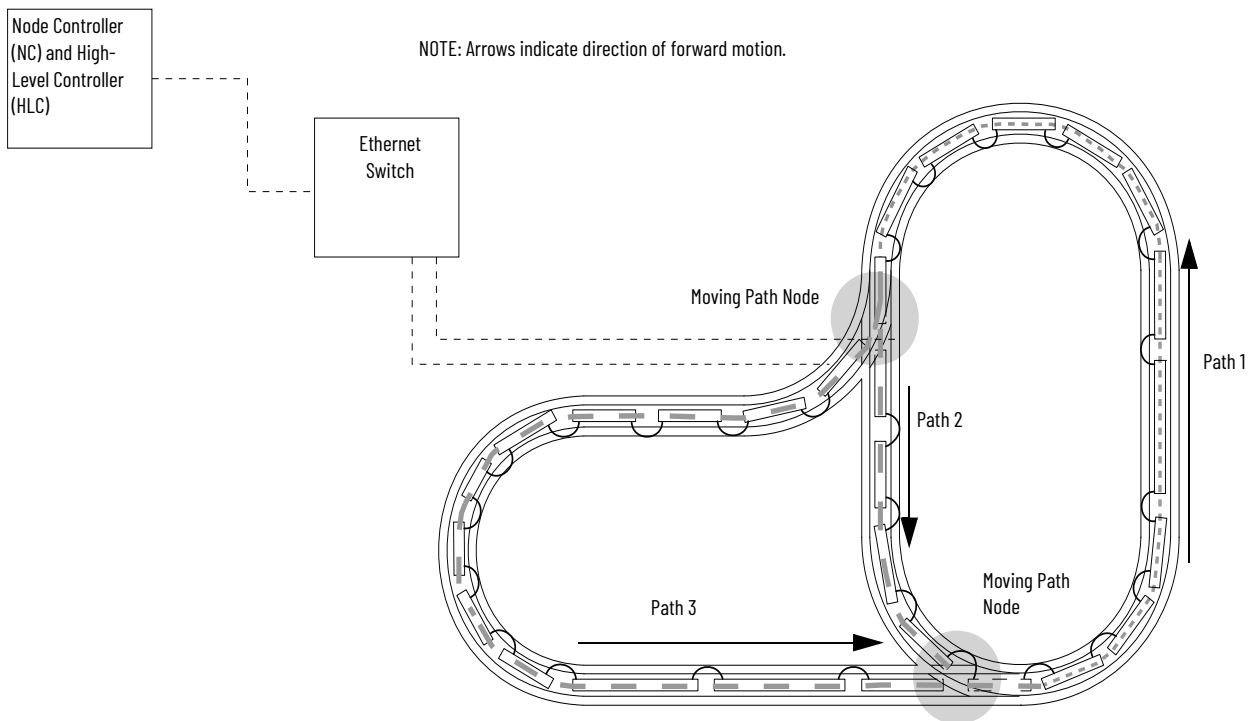

## Additional Components

The remaining components and connections must be defined on the QS 150 transport system layout, see [Figure 12](#) for an example. If node controllers with digital I/O are being used, E-stop buttons, interlocks, and light stacks can be configured, and have their locations identified.

**Power Wiring** – Identifies the power connections between motors that are connected to the same power supply.

**Power Supplies** – DC power supplies are required for powering the QuickStick 150 motors. See [Table 10 on page 39](#) for power supply sizing.

Figure 11 - Example Power Supply: 1606-XLS960 Shown

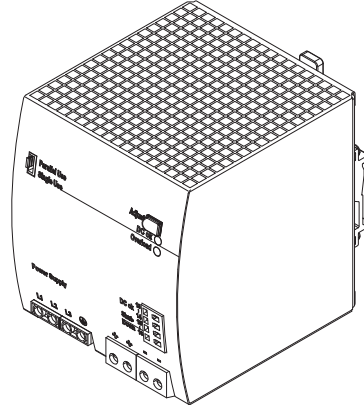

**Ethernet Switches** – Ethernet switches provide signal routing from the host controller to the node controllers and between node controllers. All node controllers must be on the same local area network subnet.

**Host Controller** – User-supplied controller that runs the application for monitoring and control of the transport system.

Figure 12 - Example QS 150 Transport System Layout Showing Additional Connections

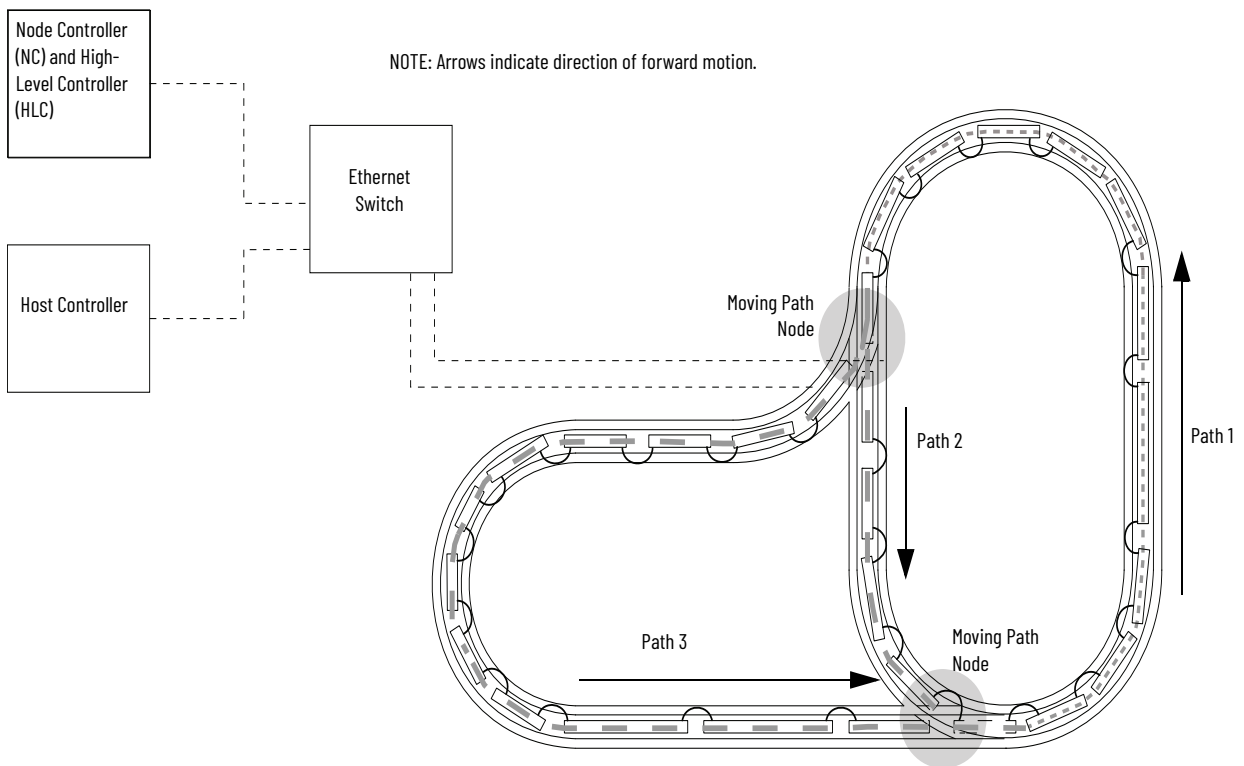

## Electrical Wiring

See [Figure 13](#) for a block diagram of a QuickStick 150 system schematic. For a detailed description of electrical wiring required for the QS 150 transport system, see the MagneMotion QuickStick and QuickStick HT Design, publication [MMI-RM001](#).

**Table 5 - Acceptable Propulsion Voltage Range for QuickStick 150 Motors**

Nominal Voltage (V DC)	Max Voltage (V DC)	Min Voltage (V DC)
48...72	79	43.2

**Figure 13 - System Wiring Block Diagram**

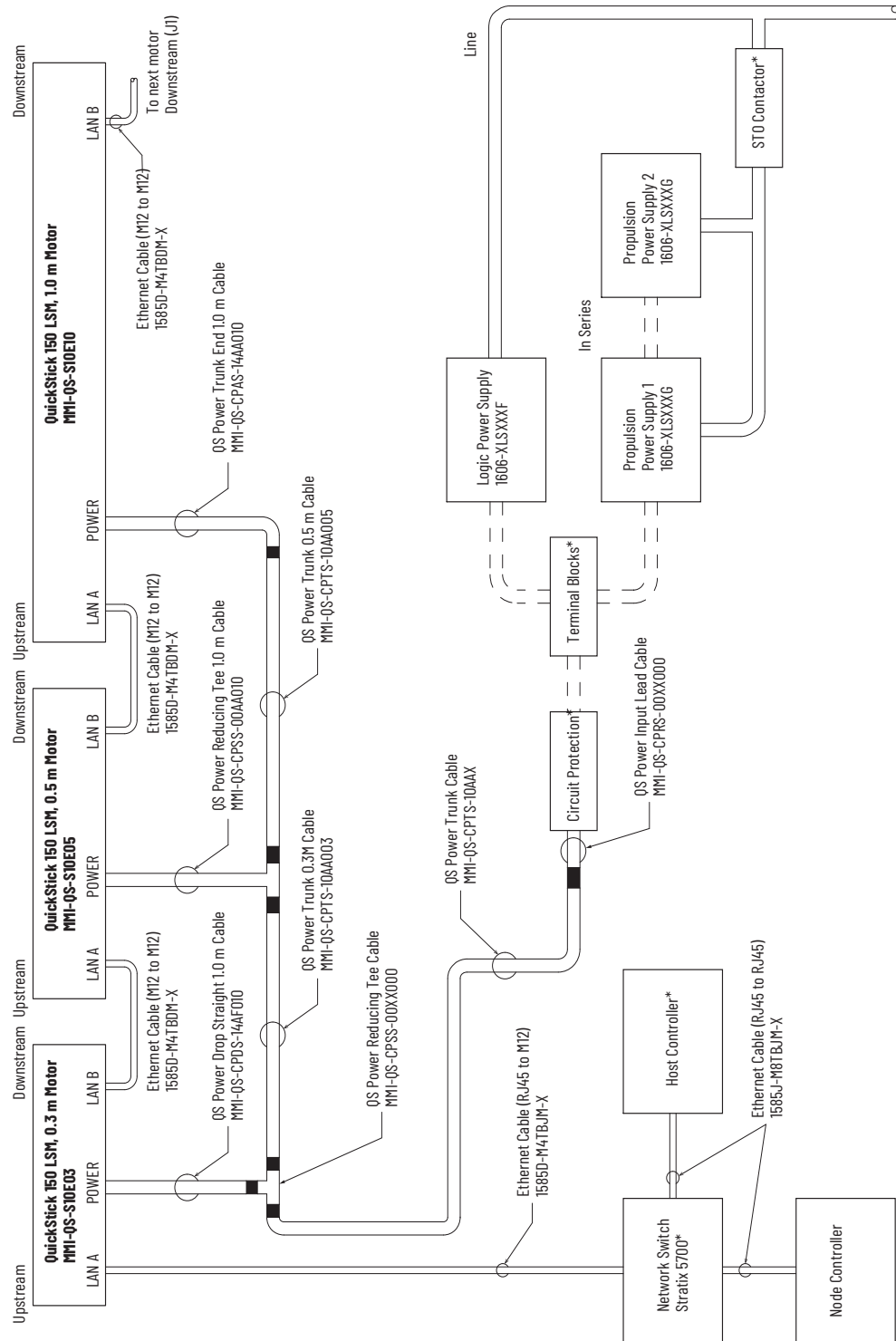

# Transport System Software Overview

Several software applications are used to configure, test, and administer a QuickStick 150 transport system as shown in [Figure 14](#) and described after the figure. See [Additional Resources on page 15](#) for communication protocol and node controller user manuals for additional information on these applications.

**Figure 14 - Simplified View of Transport System Software Relationships**

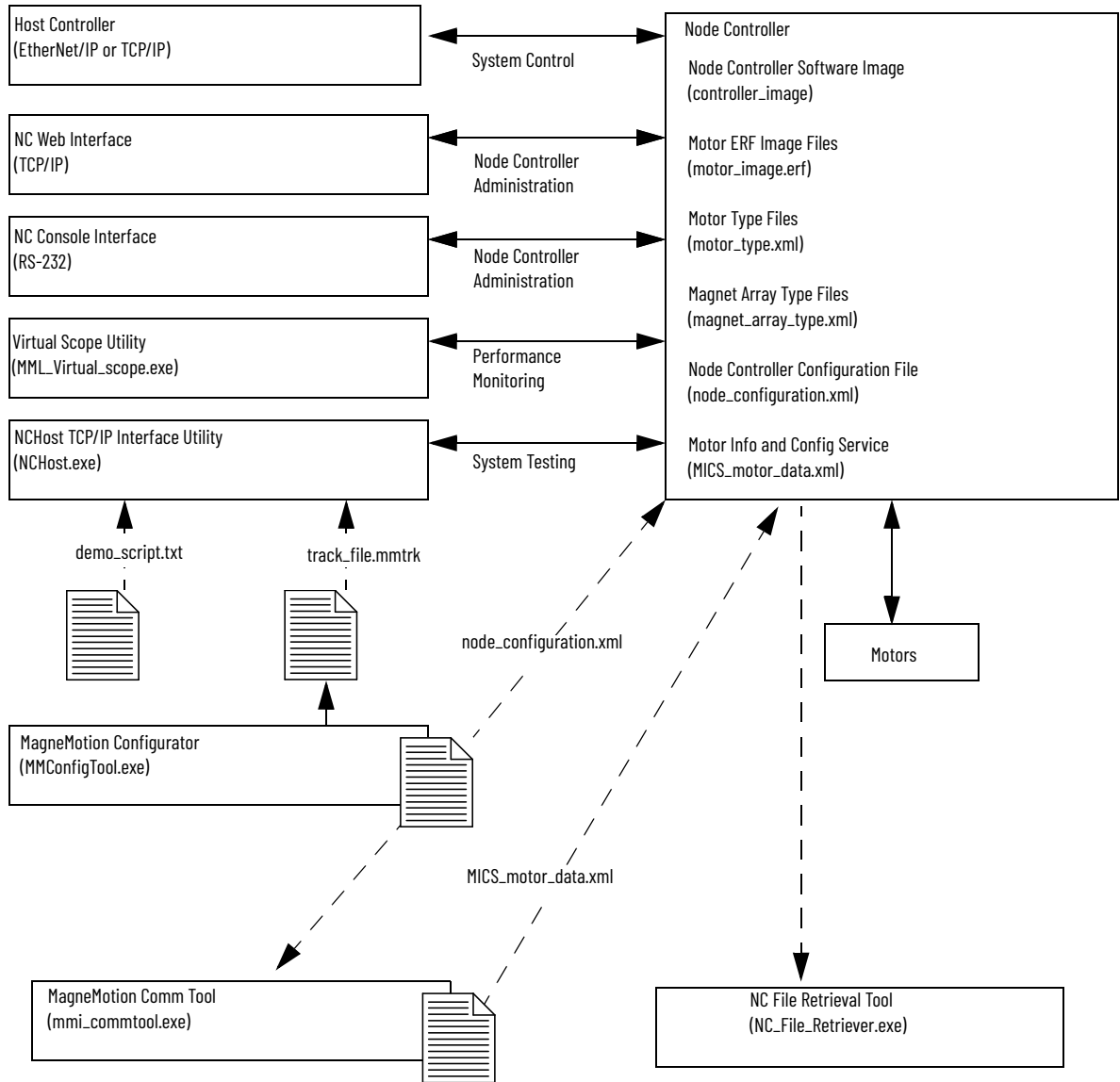

**IMPORTANT** Modifications to the image or type files could cause improper operation of the transport system.

### Software

All QuickStick 150 motors ship with a basic software image installed. For additional information see [Software on page 66](#).



All software running on the QS 150 transport system must be part of the same release. See the release notes that are provided with the software for additional information.

Only qualified Rockwell Automation personnel or personnel that are directed by Rockwell Automation should make alterations or changes to the software.

## Getting Started with the QuickStick 150 Transport System

Use this manual as a guide and reference when installing or servicing the QS 150 motors in a transport system. Follow the steps in this section to get the entire transport system operational quickly with the aid of the other manuals, see [Additional Resources on page 15](#).



Make sure that all components and complete design specifications, including the physical layout of the transport system, are available before starting to install or test the QS 150 transport system.

Before you start with the transport system:

1. Move the files and folders from the QS 150 transport system software package to a folder on a computer for user access.
2. Create the Node Controller Configuration to define the components and operating parameters of the transport system:
  - a. Create the node\_configuration.xml file
  - b. Set the node controller IP addresses
  - c. Specify the node controller to be used as the HLC
  - d. Create and upload the MICs file.

See MagneMotion System Configurator User Manual, publication [MMI-UM046](#) and MagneMotion Node Controller Interface User Manual, publication [MMI-UM001](#) for information.



The minimum requirements for running software applications are a general-purpose computer (PC) running Microsoft® Windows® 7 with .NET 4.0, an Ethernet port (web interface), and an RS-232 port (console interface).

3. Install the components of the QS 150 transport system as described in the MagneMotion QuickStick and QuickStick HT Design Guide, publication [MMI-RM001](#):
  - e. Prepare the facility for the installation:
    - Safety Considerations.
    - Site Requirements.
  - f. Install and setup all components and infrastructure, not including the motor, magnet array, or vehicles.
  - g. Prepare the motor, magnet array, and vehicles for installation and install:
    - [Unpacking and Inspection on page 47](#).
    - [QuickStick 150 Motor and Magnet Array Installation on page 49](#).
4. Verify that the system installation is complete and that the system is ready for use:
  - [System Check-out on page 63](#).
  - [System Power-up on page 64](#).
5. Program the motors using the Motor ERF Image files, see [Motor Software Installation on page 67](#), the MagneMotion Node Controller Interface User Manual, publication [MMI-UM001](#), and the MagneMotion NCHost TCP/IP Interface Utility User Manual, publication [MMI-UM010](#).
6. Test and debug the transport system by using the NCHost TCP/IP Interface Utility and Demo Scripts. See [System Testing on page 67](#) and the MagneMotion NCHost TCP/IP Interface Utility User Manual, publication [MMI-UM010](#). NCHost provides an easy method to verify proper operation and make adjustments such as refining the control loop tuning.



The NCHost TCP/IP Interface Utility is for test and verification trials only. The host controller must be used to control the QS 150 transport system after verification of functionality.

7. Configure the host controller (either a general-purpose computer or PLC) to control the QS 150 transport system as required to meet the material movement needs of the facility where the system is installed. See:
  - [Transport System Operation on page 85.](#)
  - [Safe Shut-down on page 86.](#)

See either the MagneMotion Host Controller TCP/IP Communication Protocol User Manual, publication [MMI-UM003](#) or the MagneMotion Host Controller EtherNet/IP Communication Protocol User Manual, publication [MMI-UM004](#) for additional information.

## Component Specifications and Identification

### QuickStick 150 Transport System Hazard Locations

The examples in this manual are included solely for illustrative purposes. Because of the many variables and requirements that are associated with any linear synchronous motor (LSM) system installation, Rockwell Automation cannot assume responsibility or liability for actual use that is based on these examples.

Figure 15 - Locations of Hazardous Points on the QuickStick 150 Transport System

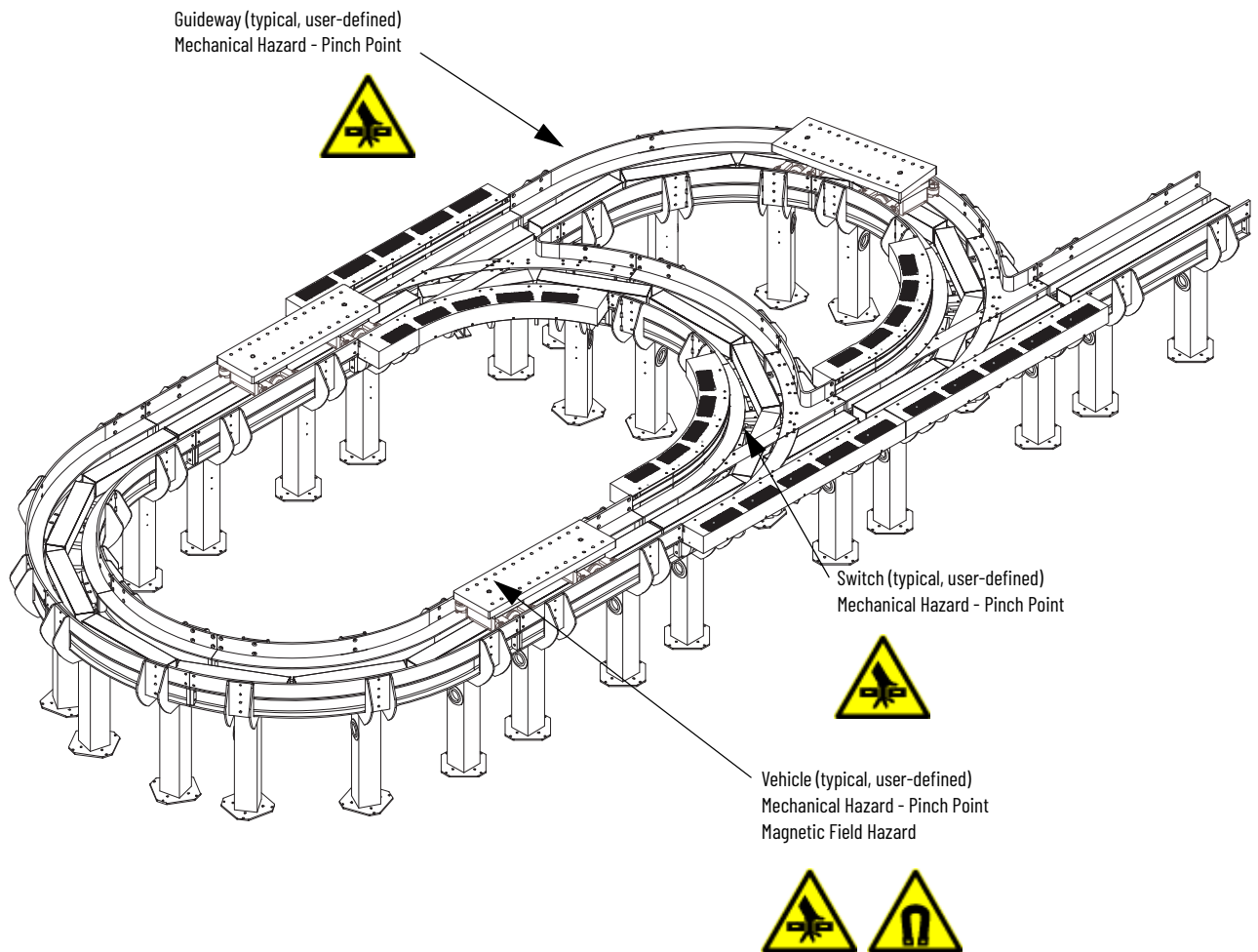

## QuickStick 150 Motors

The QuickStick® 150 motors can be mounted in any orientation: right side up, sideways, upside down, and vertically. QS 150 motors have a required direction, with an upstream end and a downstream end. The QuickStick 150 motors must always be installed with the upstream end of one motor following the downstream end of the previous motor. Forward vehicle motion on the QuickStick 150 motors is from upstream to downstream, however vehicles can move backwards (downstream to upstream) if necessary.

### Catalog Number Explanation for Motors

Use the catalog number diagram that follows to understand the configuration of your QuickStick 150. For questions regarding product availability, contact your local distributor.

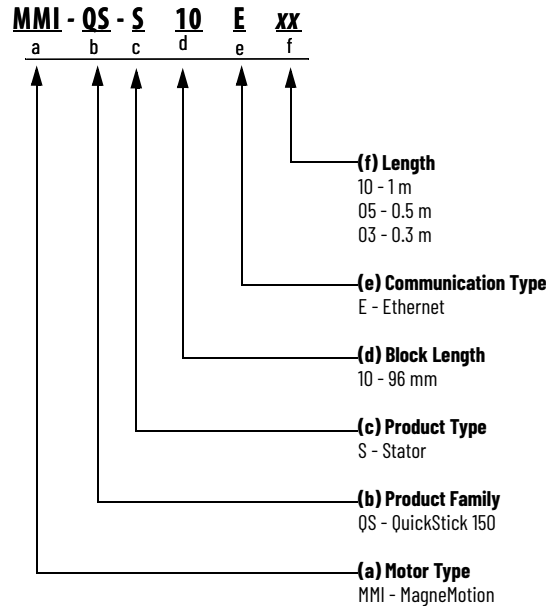

Lower-case letters shown under the catalog number indicate the catalog number position.

QuickStick 150 catalog numbers and performance specifications.

Table 6 - QuickStick 150 Catalog Numbers

Catalog No.	Input Current A 0-pk	Input Voltage	Output Current - Continuous A 0-pk	Output Current - Peak A 0-pk
MMI-QS-S10E10	15.0	Propulsion: 48...72V DC ±%10  Control: 48V DC ±%10	2.0	7.5
MMI-QS-S10E05	8.0			
MMI-QS-S10E03	5.0			

### Motor Label Identification and Location

Safety labels and identification labels are placed on those QuickStick 150 components that require them. These labels provide operators and service personnel with hazard identification and information about the QS 150 components at the point of use.



Label images are representative only. The actual label includes all appropriate regulatory symbols and can differ in appearance. Label placement can cause labels to be visible only during maintenance operations.

To replace a lost or damaged label, contact [Rockwell Automation Support](#).



**Table 7 - Example Labels Used on the QuickStick 150 Motors**

	<p>Product Information Label Qty: 1 Location: On the side of the motor (upstream end). See <a href="#">Figure 16</a>.</p>
--	---

**Figure 16 - Location of Label on the QuickStick 150 Motor**

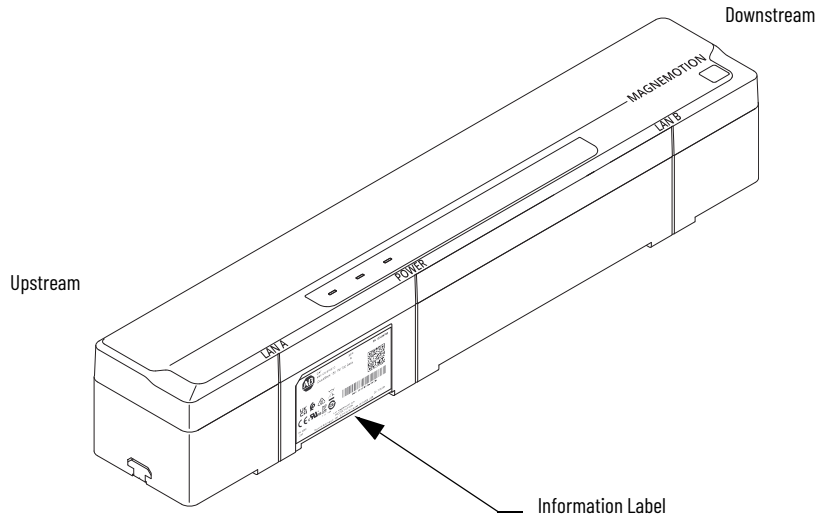

### Motor Dimensions

QuickStick 150 motor components are designed to metric dimensions. Inch dimensions are conversions from millimeters. Dimensions without tolerances are for reference. The QuickStick 150 motor envelope is backward compatible to the QuickStick 100 motor. Dimensions are shown in millimeters (inches). Dimensions are not intended to be used for manufacturing purposes.

Refer to the table for the notes in the [Figure 17...Figure 19](#).

Note	Description
1	Shading in the dimension drawings ( <a href="#">Figure 17</a> ... <a href="#">Figure 19</a> ) indicates the clearance needed for power and communication cable connector and wire bend radius. See also <a href="#">Cable Mounting Clearances</a> .
2	The centerline dimension for each connector is measured from the centerline of the motor.
3	T-slot accommodates Bosch™ 10 mm T-slot hardware (e.g. M8x1.25 mm; 10 mm T-block and spring Bosch p/n: 3842528735 or 3842516669).
4	Do not allow mounting slot to protrude beyond top surface of the T-nut when fully torqued.

Figure 17 - 1.0 Meter Motor (MMI-QS-S10E10) Mechanical Drawing

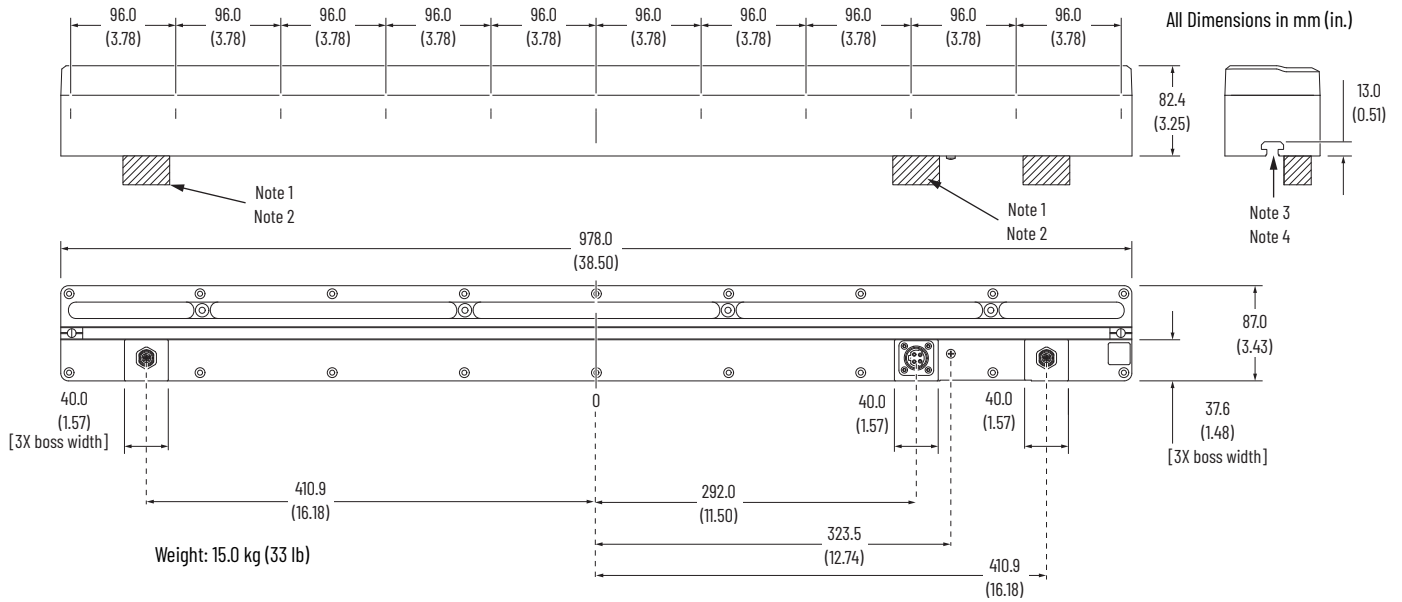

Figure 18 - 0.5 Meter Motor (MMI-QS-S10E05) Mechanical Drawing

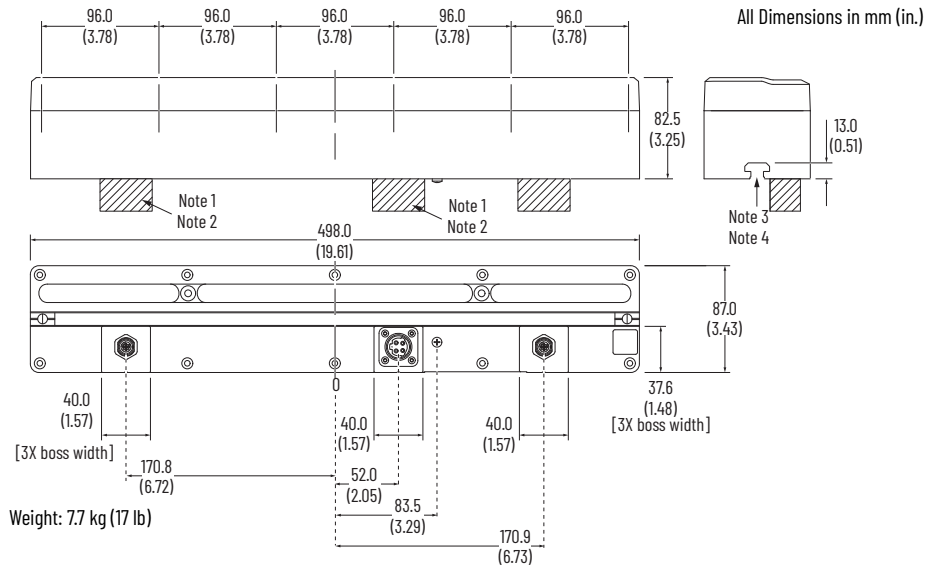
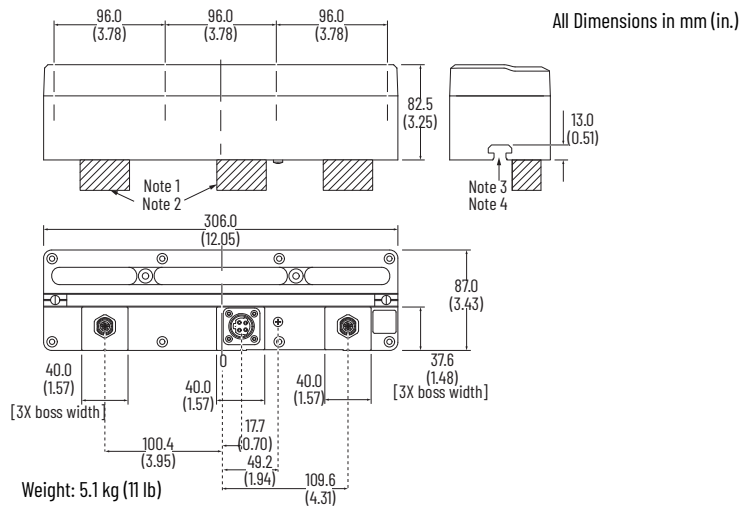

Figure 19 - 0.3 Meter Motor (MMI-QS-S10E03) Mechanical Drawing



### Cable Mounting Clearances

Shading in the dimension drawings (Figure 17...Figure 19) indicates the clearance needed for power and communication cable connector and wire bend radius. The graphic and tables below summarize the clearance information. Dimensions are shown in millimeters (inches). Dimensions are not intended to be used for manufacturing purposes.

Item	Dimension mm (in.)
------	--------------------

Straight Cables	
1	31.8 (1.3)
2	203.2 (8.0)
3	88.9 (3.5)
4	25.4 (1.0)
5	31.8 (1.3)
6	88.9 (3.5)
7	25.4 (1.0)

Right Angle Cables	
1	88.9 (3.5)
2	57.2 (2.3)
3	38.1 (1.5)
4	25.4 (1.0)
5	203.2 (8.0)
6	25.4 (1.0)
7	38.1 (1.5)
8	63.5 (2.5)
9	63.5 (2.5)

**Straight Cables**

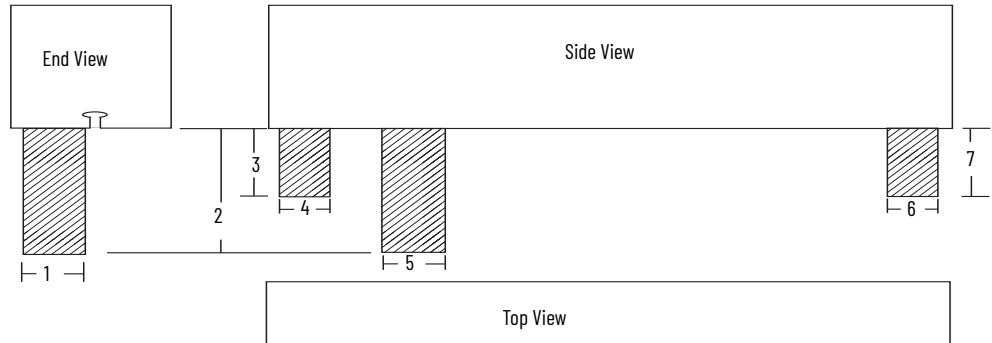

**Right Angle Cables**

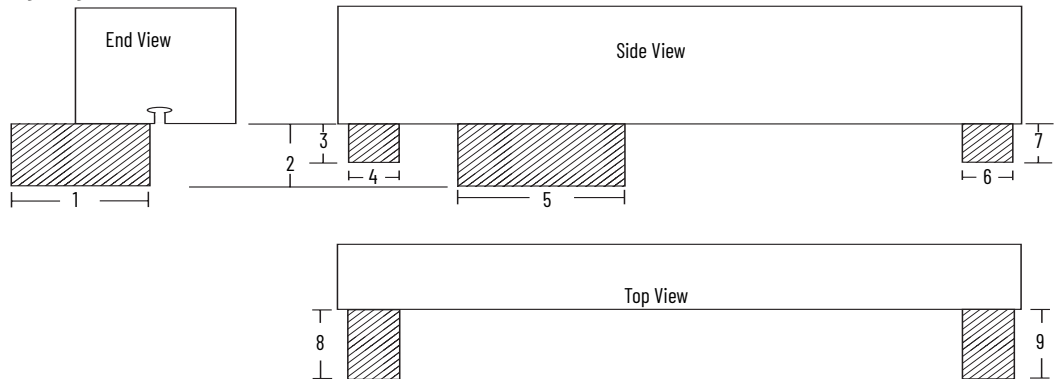

Views in these figures are not to scale.

## QuickStick 150 Power Cables

The QuickStick 150 motor uses a trunk cable (from motor-to-motor or back to the power supply) and drop cables to provide power to the motors. This drop cable and tee connects the motor power to a nearby trunk cable. Each wire in the cable are labeled for identification.

### Catalog Number Explanation for Cables

Use the catalog number diagram that follows to understand the QuickStick 150 cable selections. For questions regarding product availability, contact your distributor. For additional information, see [Motor Electrical Connections on page 41](#) and the QuickStick Motors Technical Data, publication [MMI-TD051](#).

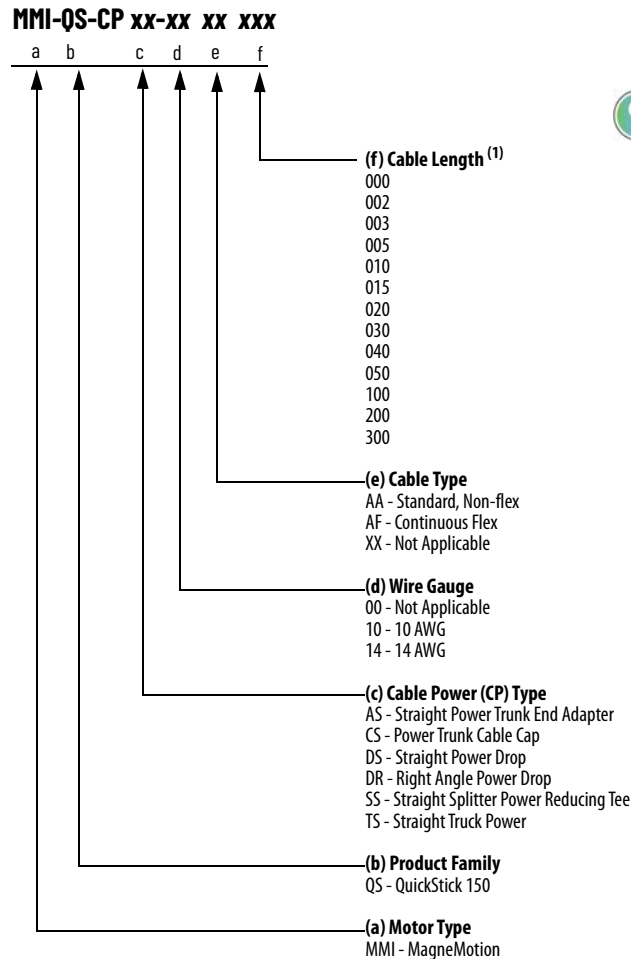

Lower-case letters shown under the catalog number indicate the catalog number position.

(1) Cable length is in decimeters, a decimeter is 0.1 m (e.g. cable length (f) 100 = 100 x 0.1 m = 10 m cable).

## QuickStick Magnet Array

The magnet array is enclosed using a stainless steel cover and is attached to the vehicle with standard hardware and acts as the QuickStick motor secondary, to move payloads through the track system.

Propulsive force applied to the vehicle scales with the magnet array coverage and motor to magnet gap. All vehicles on a track system must be the same length and use the same type of magnet array.

The stainless steel covered magnet array is available in two widths. Both widths are available in lengths from 3 cycles to 20 cycles, see [Table 8 on page 37](#) and [Catalog Number Explanation for Magnet Arrays](#). The quantity and locations of the mounting holes vary based on the size of the array.

## Catalog Number Explanation for Magnet Arrays

Use the catalog number diagram to understand the configuration of your magnet array.

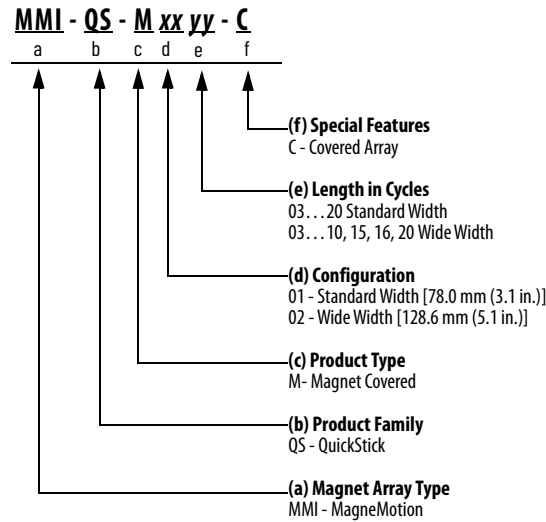

Lower-case letters shown under the catalog number indicate the catalog number position.

## Mechanical Specifications

[Table 8](#) and [Figure 20](#) describe the mechanical specifications of the QuickStick magnet array.

**Table 8 - QuickStick Magnet Array Lengths and Weights**

Cycle Length	Catalog Number <sup>(1)</sup>	Length mm (in.)	78.0 mm (3.07 in) Standard Width (-01)	128.6 mm (5.06 in) Wide Width <sup>(2)</sup> (-02)
			Weight kg (lb)	Weight kg (lb)
03	MMI-QS-Mxx03-C	142.4 (5.6)	0.9 (2.1)	1.5 (3.4)
04	MMI-QS-Mxx04-C	190.5 (7.5)	1.2 (2.7)	2.0 (4.5)
05	MMI-QS-Mxx05-C	238.5 (9.4)	1.6 (3.4)	2.5 (5.6)
06	MMI-QS-Mxx06-C	286.5 (11.3)	1.9 (4.1)	3.1 (6.7)
07	MMI-QS-Mxx07-C	334.5 (13.2)	2.2 (4.8)	3.6 (7.9)
08	MMI-QS-Mxx08-C	382.5 (15.1)	2.5 (5.5)	4.1 (9.0)
09	MMI-QS-Mxx09-C	430.5 (16.9)	2.8 (6.2)	4.6 (10.1)
10	MMI-QS-Mxx10-C	478.5 (18.8)	3.1 (6.9)	5.1 (11.2)
11	MMI-QS-M0111-C	526.5 (20.7)	3.4 (7.4)	—
12	MMI-QS-M0112-C	574.5 (22.6)	3.7 (8.1)	—
13	MMI-QS-M0113-C	622.5 (24.5)	4.0 (8.8)	—
14	MMI-QS-M0114-C	670.5 (26.4)	4.3 (9.5)	—
15	MMI-QS-Mxx15-C	718.5 (28.3)	4.7 (10.4)	7.6 (16.8)
16	MMI-QS-M0116-C	766.5 (30.2)	5.0 (11.0)	8.0 (17.6)
17	MMI-QS-M0117-C	814.5 (32.1)	5.3 (11.7)	—
18	MMI-QS-M0118-C	862.5 (34.0)	5.6 (12.3)	—
19	MMI-QS-M0119-C	910.5 (35.9)	5.9 (13.0)	—
20	MMI-QS-Mxx20-C	958.5 (37.8)	6.2 (13.7)	10.2 (22.4)

(1) In the catalog number the xx represents the widths (-01) and (-02).

(2) Wide magnet arrays are typically used when motors are arranged in a curve to provide better motor coverage.

Figure 20 - Covered Magnet Array Mechanical Drawing

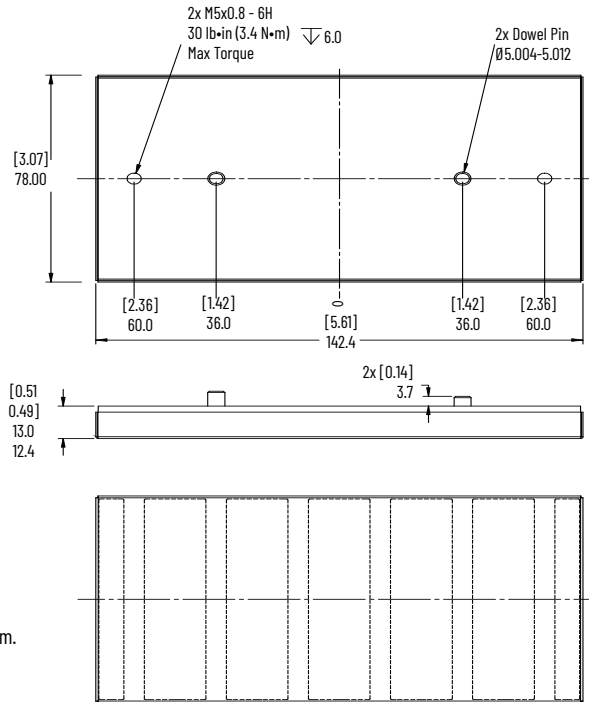

### Magnet Array Label and Identification

[Table 9](#) lists the labels that are affixed to the QS magnet array.

Table 9 - Example Labels Used on the QuickStick 150 Standard Covered Magnet Arrays



	<p>Product Information Label Qty: 1 Location: On the mounting surface of the magnet array. See <a href="#">Figure 21</a>.</p>
	<p>Magnet Hazard Label Qty: 1 Location: On the mounting surface of the magnet array. See <a href="#">Figure 21</a>. Hazard Type: Magnetic field Possible injuries: Pinch between magnet arrays, danger to medical implants and other electronics</p>

Figure 21 - Locations of Labels on the QuickStick Covered Magnet Array

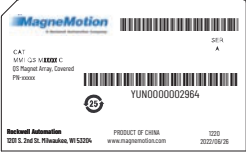

## Motor Connections

This section provides information on motor specifications and connections.

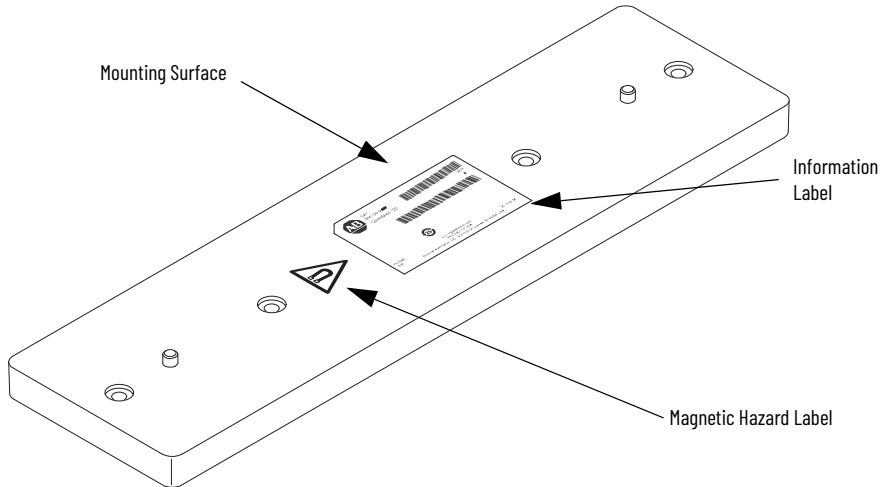
**IMPORTANT** Typical control power depends on load demand from vehicles.

**Table 10 - QuickStick 150 Electrical Specifications**

Attribute	QuickStick 150
Control Input Power <sup>(1)</sup>	48V DC ±10%
Input Propulsion Power <sup>(2)</sup>	48...72V DC ±10% (43...79V DC)
Stall Current	1.5 A
Maximum Regenerated Power	See QuickStick and QuickStick HT Design Guide, publication <a href="#">MMI-RMQ01</a> for information on power regeneration.
Lowest Propulsion Power	43V DC
Maximum Propulsion Bus Voltage	83V DC
Operating Voltage (not for direct connection to AC line)	48...72V DC
Nominal DC Bulk Capacitance (per inverter)	> 100 µF
Motor Control Power (max power)	1 m – 10 W, 48V DC ±10%, 0.5 A max
	0.5 m – 5 W, 48V DC ±10%, 0.5 A max
	0.3 m – 5 W, 48V DC ±10%, 0.5 A max
Propulsion Inverter Output Current, Continuous (0-pk)	2.0 A
Propulsion Inverter Output Current, Peak (0-pk)	7.5 A
Vehicle – Propulsion Power <sup>(3)</sup>	Variable
Stall Threshold Current	4 A
Active Stall Time-out Current	5 seconds (time when the drive has not moved the load more than one cycle)

(1) The number of cycles per minute the control input power is allowed to apply and remove from the drives must not exceed 1 cycle every 10 seconds.

(2) The number of cycles per minute the propulsion bus input power is allowed to apply and remove from the drives must not exceed three cycles every 1 minute.

(3) The motor draws maximum power when the vehicle is moving at maximum acceleration and velocity. Contact [Rockwell Automation Support](#) for help with determining the correct power supply size based on the motor application and size of the magnet array.

**IMPORTANT** The motors draw additional power when the vehicle is moving or accelerating (see [Table 10 on page 39](#)). The amount of additional power that is drawn depends on the velocity and acceleration of the vehicle, the number of vehicles accelerating, and the magnet array length.

- All power wiring must be sized to carry the full load and have proper circuit protection.
- The propulsion power input uses a positive temperature coefficient (PTC) resistor to limit inrush current upon application of power. The PTC is only used for inrush current limiting and is bypassed in normal operation. Limit propulsion power cycling to 40 seconds (30 seconds from on to off and 10 seconds between turn off and turn on). See also [Soft Start on page 82](#).
- When using separate power sources for logic and propulsion power, the propulsion power and control power returns must be tied to ground.
- Providing a separate power source for the logic power allows the motors to be programmed and configured without enabling the propulsion power.



**ATTENTION:** Never disable propulsion power by switching the propulsion input pin of the motor from the DC power source directly to ground. Switching the input to ground produces large current spikes that can damage the electronics.

- Any user-supplied power supply must comply with the applicable local and national safety codes.
- Do not plug or unplug the power cables if the power supply is turned on.

[Table 11](#) and [Figure 22 on page 41](#) provide guidance on power cable bend radius requirements.

**Table 11 - Cable Bend Radius**

Type of Bend Radius	Type of Cable	Description
Static bend radius	Standard (non-flex)	The static (installation) bend radius and dimension B in <a href="#">Figure 22</a> is: <ul style="list-style-type: none"> <li>• 10 times the cable diameter for all cable types except MMI-QS-CPDR-14AFxxx.</li> </ul>
	Continuous-flex	<ul style="list-style-type: none"> <li>• Do not begin a static bend inside dimension B in <a href="#">Figure 22</a> is:</li> <li>• Use this measurement when routing the cable in a non-flex application between motor and controller (the bend area).</li> <li>• The bend area is where standard (non-flex) or continuous-flex cables can be bent to their specified bend radius.</li> </ul>
Continuous bend radius	Continuous-flex	The continuous bend radius for single motor cables is: <ul style="list-style-type: none"> <li>• 10 times the cable diameter for MMI-QS-CPDR-14AFxxx cables.</li> <li>• Secure the continuous-flexing area, the recommended cable diameters (dimension B in <a href="#">Figure 22</a> is:) from each end of the cable, with a rigid mount that helps prevent the cable from flexing where it connects to the motor or shield clamp. Refer to the cable carrier manufacturer's recommendations for procedure and dimensions related to flexing applications.</li> <li>• Use this measurement when routing the cable in a continuous-flex application between motor and drive (the continuous-flexing area).</li> <li>• The continuous flexing area is where continuous-flex cables can be flexed repeatedly.</li> <li>• Install the cable along the neutral axis to make sure that the cable is not in contact with the inner radius of the cable carrier while flexing.</li> </ul>



Figure 22 - Cable Bend Radius

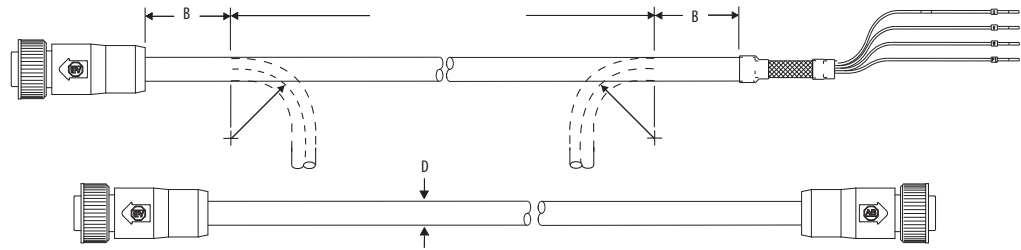

Table 12 - Cable Bend Radius

Cable Cat. No.	Wire Size	D mm (in.)	B mm (in.)	Static (installation) Bend Radius mm (in.)	Continuous Bend Radius mm (in.)	Expected Flex Cycle at Rated Radius
MMI-QS-CPSS-00XX000 <sup>(1)</sup>	10 AWG trunk 14 AWG drop	–	–	–	–	–
MMI-QS-CPSS-00AAxxx	10 AWG trunk 14 AWG drop	10.2 (0.4)	50.8 (2.0)	10.2 (0.4)	–	–
MMI-QS-CPDS-14AFxxx	14 AWG	10.2 (0.4)	50.8 (2.0)	101.6 (4.0)	101.6 (4.0)	10 million
MMI-QS-CPDR-14AFxxx	14 AWG	10.2 (0.4)	50.8 (2.0)	101.6 (4.0)	101.6 (4.0)	10 million
MMI-QS-CPCS-00XX000	–	–	–	–	–	–
MMI-QS-CPAS-14AAxxx	10 AWG	13.5 (0.5)	50.8 (2.0)	134.6 (5.3)	–	–
MMI-QS-CPTS-10AAxxx	10 AWG	13.5 (0.5)	50.8 (2.0)	134.6 (5.3)	–	–
MMI-QS-CPRS-00XX000	10 AWG	4.6 (0.2)	25.4 (1.0)	45.7 (1.8)	–	–

(1) This is only a tee, there is no cable attached.

### Motor Electrical Connections

The QS 150 motor uses a trunk bus cable with power drop cable system to provide power to the motor.

- Contact [Rockwell Automation Support](#) for replacement cables.
- See [Figure 24...Figure 31](#) for cable identification and pin out information.
- See QuickStick Motors Technical Data, publication [MMI-TDo51](#) for specifications.

Figure 23 - Motor Electrical Connections

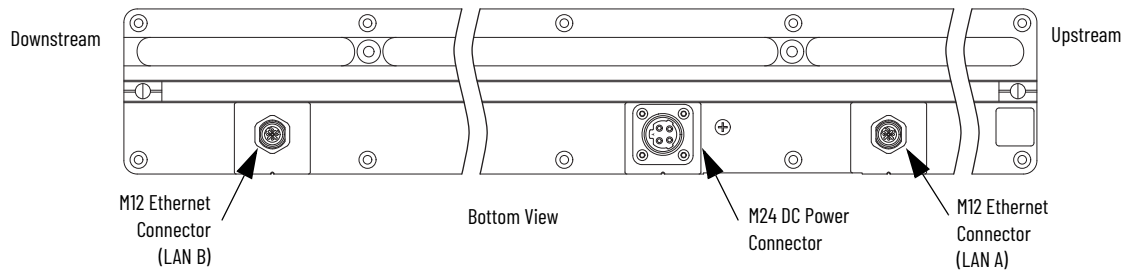

Table 13 - Motor Connections

Label	Description	Connector Type
Power	DC Power Connector	M24
LAN A	Ethernet	M12
LAN B	Ethernet	M12

Table 14 - Power Connector Pinout

Pin	Description
1	DC Return
2	48V DC Control
3	48V DC Propulsion
4	PE (ground)

**Figure 24 - Power Reducing Tee (MMI-QS-CPSS-00XX000)**

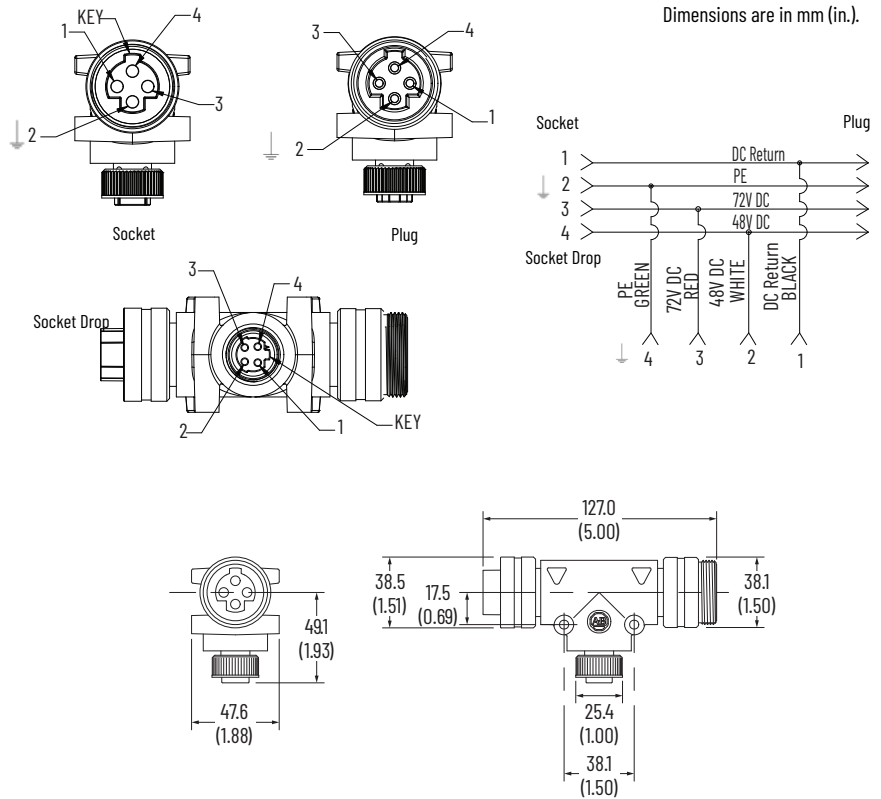

**Figure 25 - Power Reducing Tee Cable (MMI-QS-CPSS-00AAxxx)**

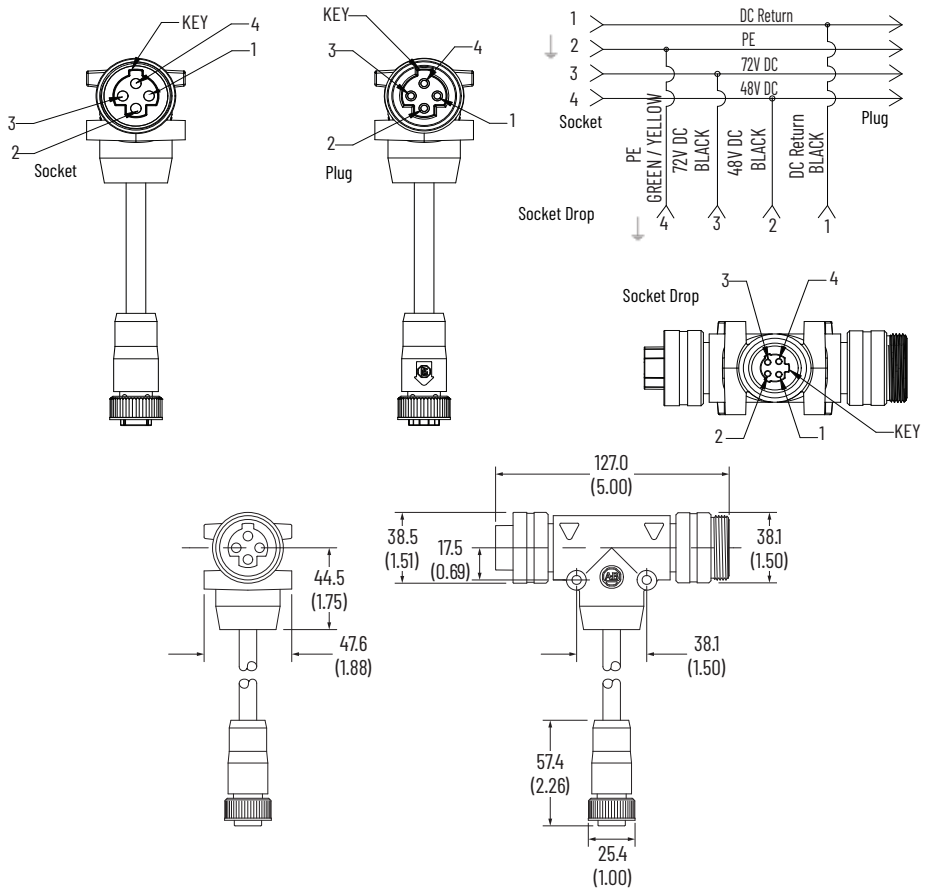

Figure 26 - Power Drop Cable (MMI-QS-CPDS-14AFxxx)

Dimensions are in mm (in.).

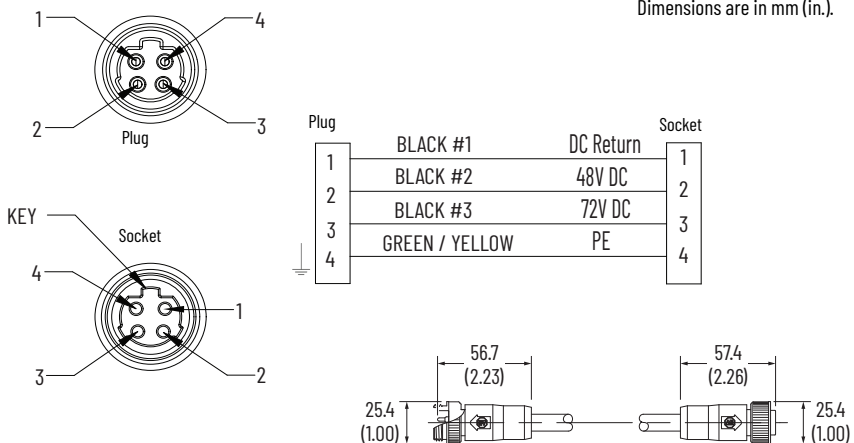

Figure 27 - Power Drop Cable (MMI-QS-CPDR-14AFxxx)

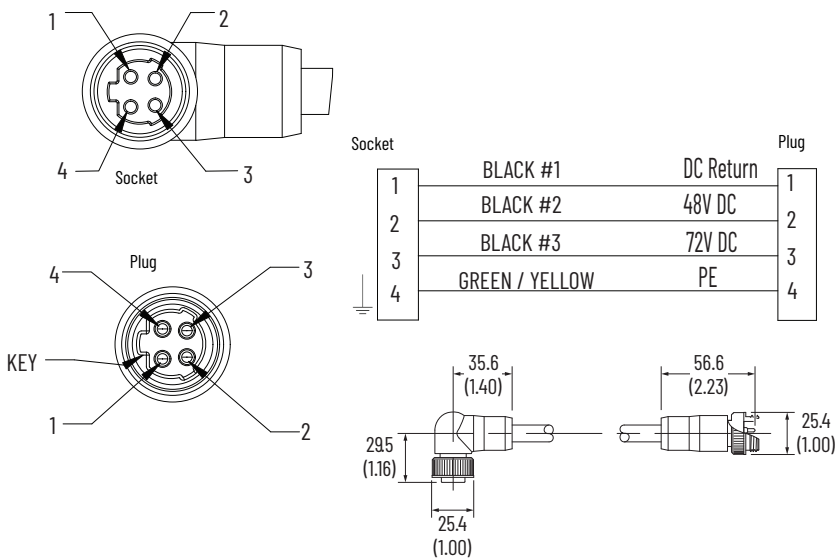
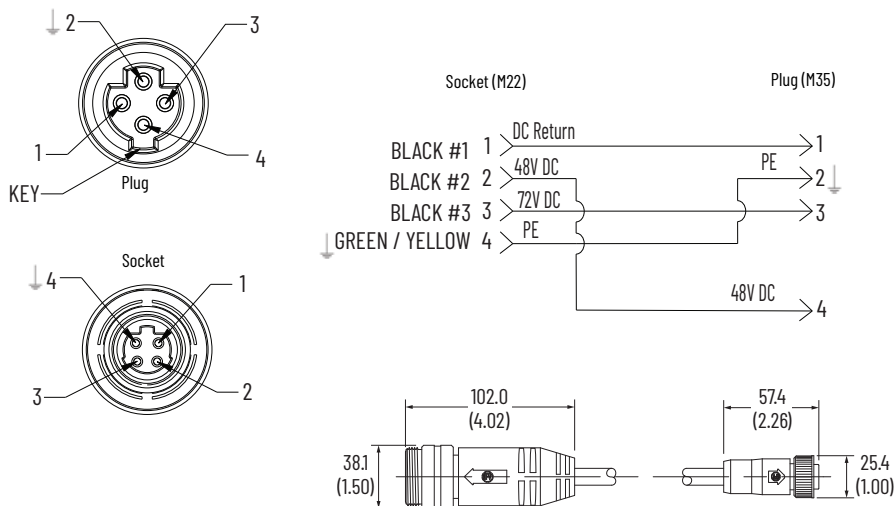
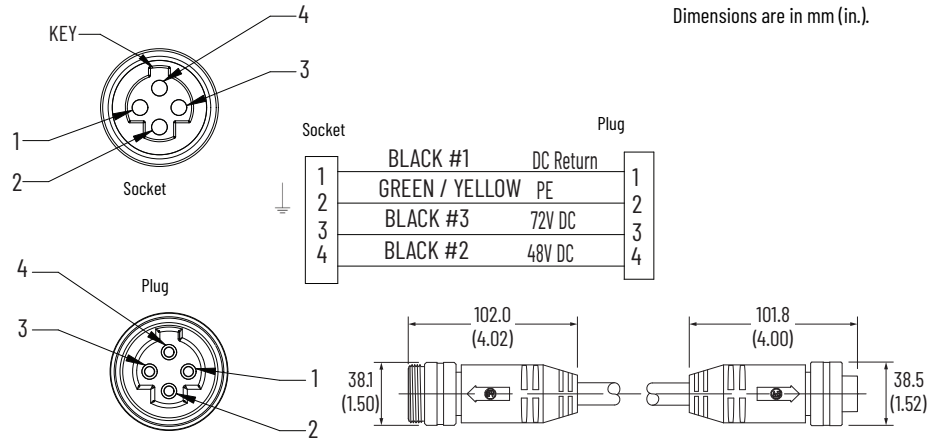

Figure 28 - Power Trunk End Cable (MMI-QS-CPAS-14AAxxx)



**Figure 29 - Power Trunk Cable (MMI-QS-CPTS-10AAxxx)**



**Figure 30 - Power Trunk Cable (MMI-QS-CPRS-00XX000)**

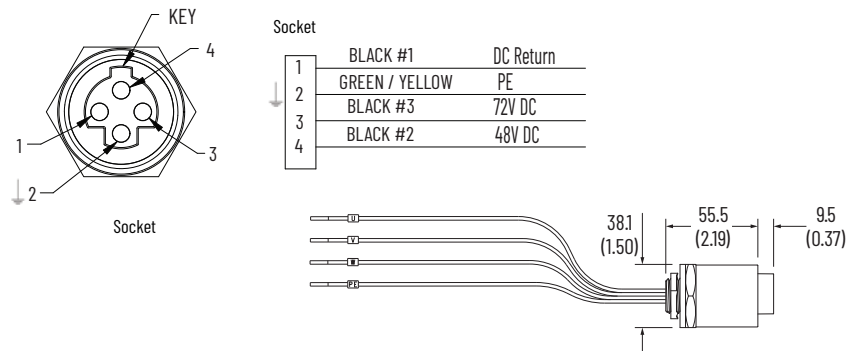

**Figure 31 - Power Trunk Cap (MMI-QS-CPCS-00XX000)**

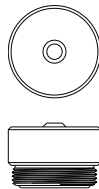

## Motor Ethernet Connections

The QuickStick 150 motor uses Ethernet communication to link to the controllers. The Ethernet cables are typically available in lengths of 0.3...80.0 m (0.98...262.5 ft). For questions regarding product availability, contact your local distributor.

**Table 15 - Ethernet Connector Pinouts**

Pin	Description
1	TX+
2	RX+
3	RX-
4	TX-

Figure 32 - Communication Cable Assembly (1585D-M4TBDM-x)

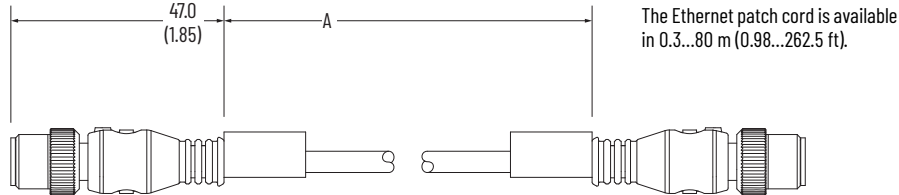

Figure 33 - Communication Cable Assembly (1585D-M4TBJM-x)

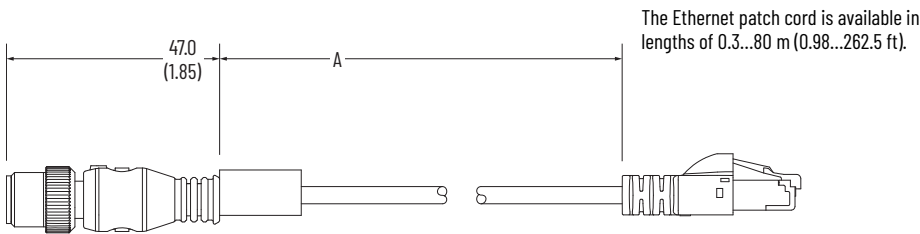
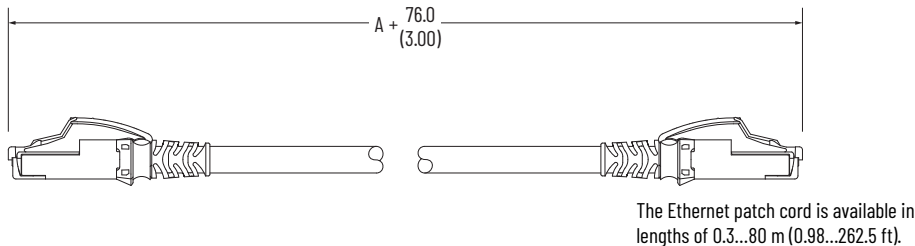

Figure 34 - Communication Cable Assembly (1585J-M8TBJM-x)



**Notes:**

## Installation

Before installing a QuickStick® 150 (QS 150) motor, the transport system and layout must be created to define the following:

- Type and location of all motors (all motors provide bidirectional motion) and switching mechanisms.
- The number of vehicles on the transport system.
- Locations of all interfaces to other equipment in the facility.
- All paths and the direction of forward motion (downstream).
- All nodes and the type of the nodes.
- All node controllers, their type, and connections.
- Identification of the node controller that is assigned as the high-level controller (HLC).
- Additional connections such as motor communications, power, and network.
- Additional functions such as E-stop, interlock, and light stack.

This chapter provides complete installation procedures for the QS 150 motors, cables, magnet arrays, and vehicles that are used in a transport system.



**SHOCK HAZARD:** Do not attempt the procedures in this document unless you are qualified to do so and are familiar with solid-state control equipment and the safety procedures in the Standard for Electrical Safety in the Workplace, publication NFPA 70E.

### Required Tools and Materials

- Metric Hex wrench set
- Torque wrench [0.9...26 N•m (8...230 lb•in) range] with metric and Torx bits
- Laser level, rotary
- Digital multimeter
- Thread locker (adhesive or lock washers)

## Unpacking and Inspection

Open each package carefully following the steps that are provided in [Unpacking and Moving Instructions](#); inspect and verify the contents against the shipping documents. Report any damage immediately to the shipper and to Rockwell Automation.



See the shipping documents for the exact contents.  
The checklist in [Table 16](#) is provided for reference only.

Table 16 - Packing Checklist Reference

Package	Contents
QuickStick 150 Motors	QuickStick linear synchronous motors (LSM).
Magnet Arrays	Magnet arrays to be attached to the vehicles for use as the LSM secondary to move material on the transport system.
Power Cables	Quantity and type will be dependent on the system size.

### Unpacking and Moving Instructions

The QS 150 components arrive from the factory ready for installation. See MagneMotion® QuickStick and QuickStick HT Design Guide, publication [MMI-RM001](#) for additional system component information.



#### Required Tools and Equipment

- Open-end wrench, adjustable
- Metric hex wrenches

	<b>WARNING</b>
	<b>Strong Magnets</b>
	<p><b>WARNING:</b> To avoid severe injury, people with pacemakers and other medical electronic implants must stay away from the magnet arrays. To avoid severe injury from strong magnetic attractive forces:</p>
	<ul style="list-style-type: none"> <li>• Handle only one vehicle or magnet array at a time.</li> <li>• Do not place any body parts, such as fingers, between a magnet array and any QS 150 motors, ferrous material, or another magnet array.</li> <li>• Magnet arrays or vehicles not being used must be secured individually in isolated packaging.</li> </ul>
	<p><b>WARNING:</b> To avoid damage to watches, instruments, electronics, and magnetic media, keep metal tools, metal objects, magnetic media (for example, memory disks/chips, credit cards, and tapes) and electronics away from the magnet arrays.</p>

	<b>WARNING</b>
	<b>Magnetic Field Hazard</b>
<p>The mover uses strong magnets. There is a risk of health hazard for persons with heart pacemakers, metal implants, hearing aids, and other medical electronic implants while in proximity of magnetic and magnetic-field producing components. The magnetic field that is generated can disrupt the functionality of automatic-implantable cardioverter defibrillator (AICD). People with cardiac pacemakers must stay away from the magnet arrays.</p>	



 	<div style="background-color: yellow; text-align: center; padding: 5px;">  <b>CAUTION</b> </div> <p style="text-align: center;"><b>Heavy Lift Hazard</b></p> <p>The QS 150 motors can weigh as much as 15.42 kg (34 lb). Failure to take the proper precautions before moving them could result in personal injury.</p> <p>Use proper techniques for lifting and safety toe shoes when moving or installing any QS 150 components.</p>
--	---

Save all shipping packaging for possible future use. If any of the QS 150 components are shipped, the original shipping packaging must be used. If the original packaging has become lost or damaged, contact [Rockwell Automation Support](#) for replacements.

1. Upon receiving the packages, visually verify that the packaging is not damaged. Inform the freight carrier and Rockwell Automation of any inspection discrepancy.
2. Open each shipping package and verify the contents against the shipping documents.
3. Carefully inspect the QS 150 components and all additional items for signs of shipping damage.
4. Move items to their destination.

## QuickStick 150 Motor and Magnet Array Installation

The QS 150 motors provide adjustable mounting features on the bottom, which provides for a simple mounting scheme, see [QuickStick 150 Motors on page 32](#). The following guidelines are provided for installing the motor mounts.

- Allow the motors to have a small amount of movement relative to each other for adjustment of the motor to motor gap during installation.
- Mounts should have consistent spaces between the motors, this simplifies the Node Controller Configuration File and provides consistent thrust.
- Mounts are coplanar to the motor tops within  $\pm 0.5$  mm to meet the standard thrust requirements.
- The motor is securely fastened and cannot move.
- All motor mount locations are used and all bolts for the mounts are fully secured.



**SHOCK HAZARD:** Do not attempt the procedures in this document unless you are qualified to do so and are familiar with solid-state control equipment and the safety procedures in the Standard for Electrical Safety in the Workplace, publication NFPA 70E.



When performing any of the following procedures, adhere to and follow all safety warnings, local and area regulation and guidelines, and installation instructions.

### Install Motor Mounts

When attaching directly to the track or mounting plate as shown in [Figure 35 on page 50](#), make sure that clearance holes for all motor connections are provided. This mounting method does not provide for any adjustment of the motor position once the motor is installed unless adjustment features are provided in the mounting plate.



**ATTENTION:** Make sure that the equipment or track system where the QuickStick 150 motors are mounted and the motor mounting surfaces are properly grounded to safety ground (earth).

**Figure 35 - Motor Mounting to Flat Surface**

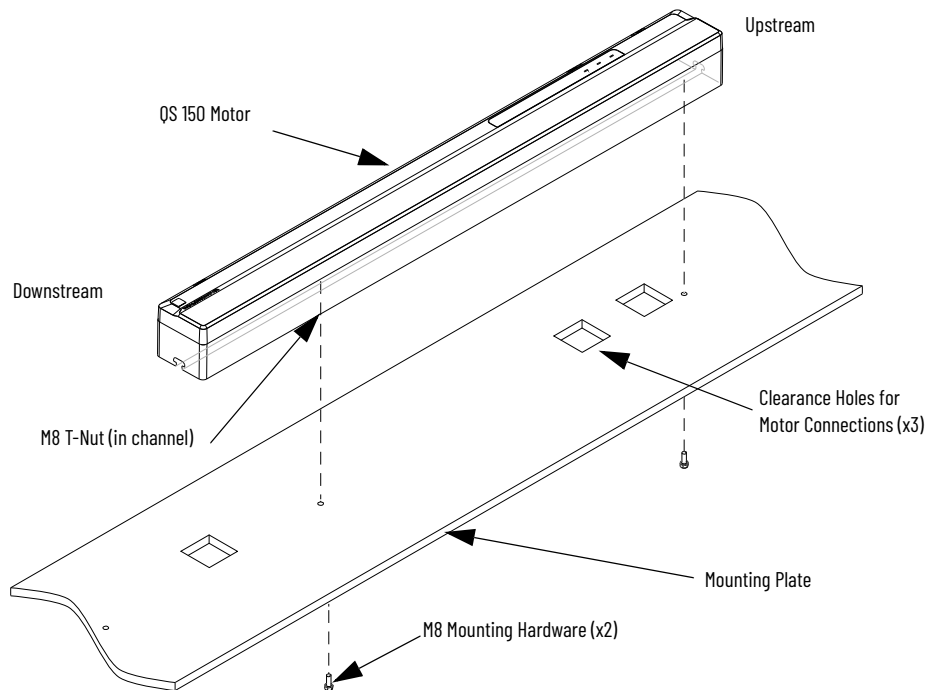

- When attaching mounting brackets to the motors as shown in [Figure 36 on page 51](#), and securing the brackets to the track, make sure that the brackets are located to allow access to all motor connections. This mounting method provides easy adjustment of the motor position once the motor is installed. See [Cable Mounting Clearances on page 35](#) for additional information.

Figure 36 - Motor Mounting Using Brackets

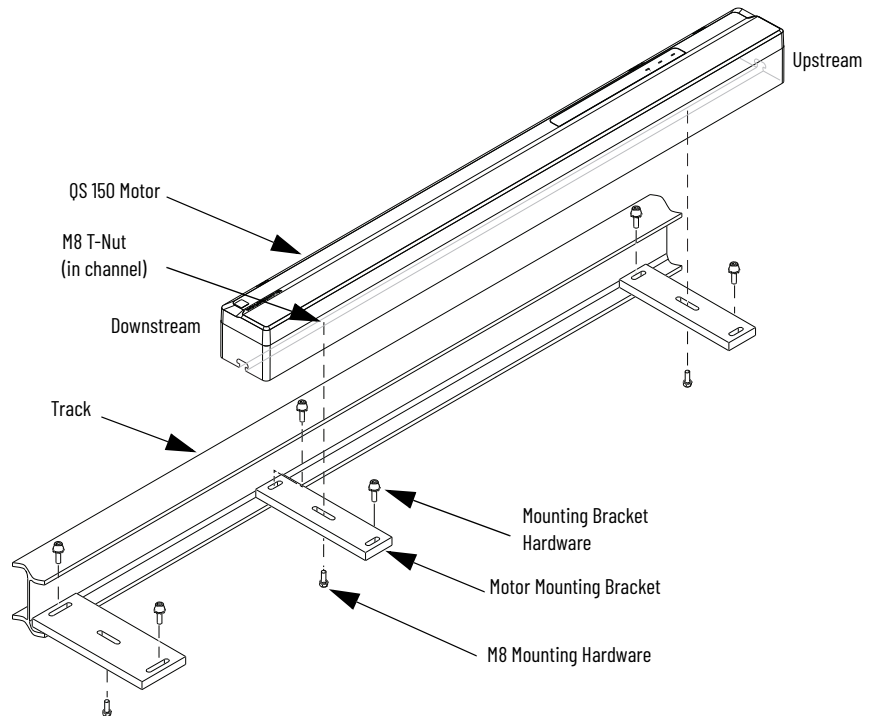

When using either of the mounting methods shown consider these requirements:

- The entire track structure should be fully designed and installed.
- Design your mounting interface to allow flexibility to adjust the motor position on the mounting brackets. The motor mounts should allow the motors a small amount of movement relative to each other.



The upstream end of the motor is the end where the power connector is located, see [Figure 50 on page 62](#).

- Make sure that there is consistent spacing between the motors.
- Make sure that the top surfaces of all motors are coplanar to each other.
- Treat each motor-to-motor interface as a separate operation, tighten the motor mounts. See [Mounting the Motors on page 52](#) for details of the mounting procedure.

Figure 37 - Alternate Guideway Detail

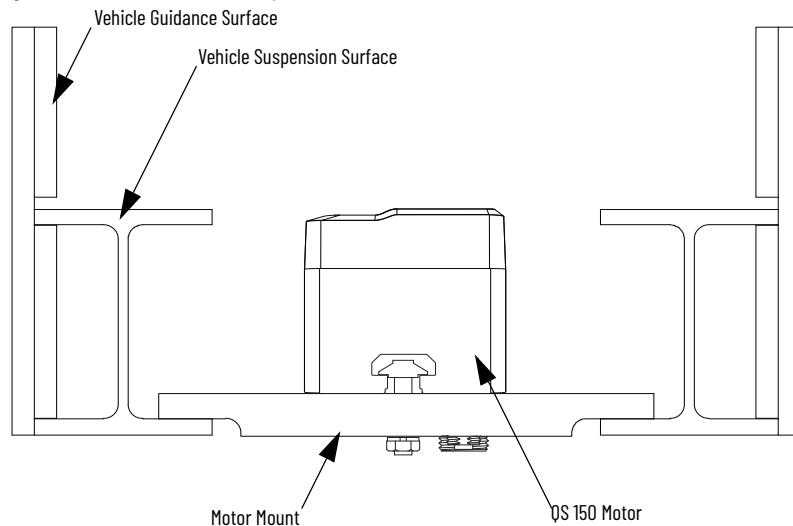

## Mounting the Motors

Motors are designed to support mounting brackets 1.5 in. (38.1 mm) wide. The motors must be attached to the motor mounts on the guideway, see [Figure 35 on page 50](#) and [Figure 36 on page 51](#) for an overview. Make sure that all motors are level once mounted.

These requirements must be met to properly install a QS 150 motor to the motor mount:

- Centered on the length of the motor and flush to both ends (x2)
- Mounted roughly at the quarter points of the motor
- Mounted flush to the end of the motor only
- Locking features such as thread locker or lock washers must be used

### Motor Mounting Locations



Center and Both Ends



Quarter-points



Both Ends

1. Locate all QS 150 motors (if not already installed) by placing the bottom of the motor on the motor mounts installed on the guideway.
2. Secure the motor using M8 bolts and M8 split lock washers through the motor mount to the M8 T-Blocks and finger tighten. Motors shall be designed to support mounting brackets 1.5 in. (38.1 mm) wide (direction of travel). The motor requires a minimum of two mounting screws in all scenarios (for example [Figure 35 on page 50](#) and [Figure 36 on page 51](#)):

The **motor mounting locations** provide both physical space for the brackets to be installed without cable interference, as well as chassis stiffness, when running at a 0 mm gap with maximum attractive force.



Make sure that the tip of the mounting bolt does not protrude beyond the T-nut to help prevent damage to the motor housing. See the engineering drawings for the locations, depths, and torques for all mounting features.



Make sure that there is sufficient space around the motor mounting surface for all connectors and for the bend radius of all cables. See [Cable Mounting Clearances on page 35](#).

3. Adjust the tops of all motors to be coplanar to each other (adjust the motor mounts as required).
4. Adjust the position of all motors to make sure that the vehicle guides are collinear to each other and the space between motor bodies is consistent with the system layout.
5. Tighten all QS 150 motor mounting hardware (typically 25 N•m [18 lb•ft] max).
6. Record and identify the [Motor Gap and Downstream Gap on page 53](#) between all motors.
7. Repeat [step 1...step 6](#) for all motors in this track section.



The motor gap must be entered for the motors in the Node Controller Configuration File. If all motors on a path have the same motor gap, it can be entered once in the motor defaults before defining the individual motors on the path, see the MagneMotion Node Controller Interface User Manual, publication [MMI-UM001](#).

8. When the track is assembled, connect the power supplies, node controllers, network switches, and cables to the motors, see [System Wiring Block Diagram on page 27](#) and [Motor Electrical Connections on page 41](#) for additional information.

	 <b>CAUTION</b>
	<p style="text-align: center;"><b>Electrical Hazard</b></p> <p>To avoid electric shock, do not open any QuickStick 150 component. Motors, controllers, and other components do not contain any user-serviceable parts.</p> <p>Do not turn on electrical power to the power supplies, motors, and node controllers until after connecting all other transport system components.</p>

9. To assemble the next section of the track system, complete [step 1](#) through [step 8](#).
10. Connect the track section to the previously assembled track section. Verify that both sections are in the same plane and level to each other.
11. Complete [Magnet Array Installation on page 54](#) and [Connecting Motors and Electronics on page 58](#).
12. Perform [Check-out and Power-up on page 63](#).
13. Complete [Vehicle Installation on page 68](#).



Install vehicles on captive closed loop systems before closing the loop to eliminate the need to remove a section of the guideway.

### Motor Gap and Downstream Gap

For QuickStick 150 motors installed in a transport system, there is always a space (motor gap) between motors, as shown in [Figure 38](#). The minimum space is 2 mm (for thermal expansion) and a typical space is 22 mm, which places 1.0 m QuickStick 150 motors on a 1.0 meter pitch.

For the QS 150 magnet arrays, the cycle length is always 48 mm and the maximum allowable gap is the length of the magnet array -120 mm. The internal gap is present on both motors involved in a gap (meaning the upstream internal gap and the downstream internal gap).

**Figure 38 - Motor Gaps**

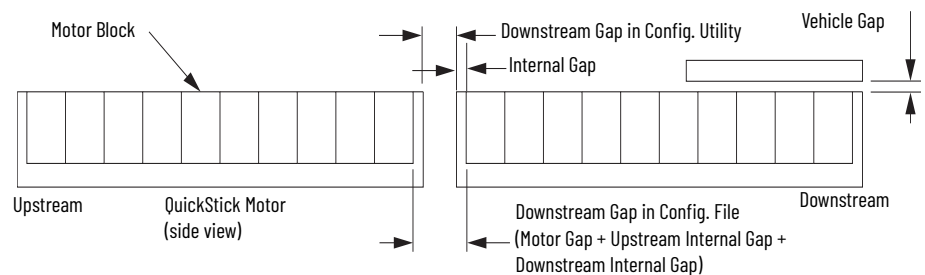

**Figure 39 - Motors on Curves**

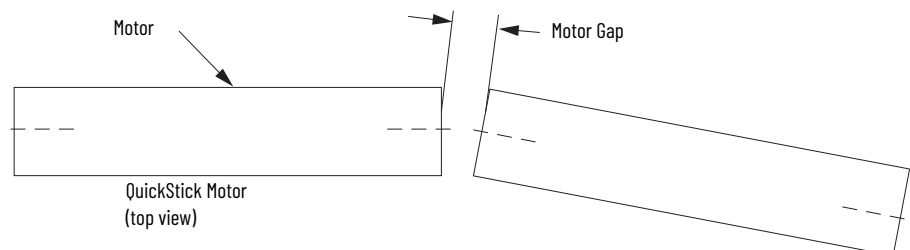

Since the motors and the magnet arrays are not curved, the alignment of the magnet array over the motors is not optimal in a curve and the alignment of

the magnet array changes as the vehicle moves through the curve. For details on curve design, see the MagneMotion QuickStick and QuickStick HT Design, publication [MMI-RM001](#).

To minimize some of this misalignment the magnet arrays that are used for curve geometry are wider than usual to provide more magnetic array coverage. A dual-array vehicle can be used, which allows the magnet arrays to stay better aligned to the motors.

---

**IMPORTANT** If **On Curve** is selected for a motor and Rockwell Automation has not supplied a unique version of software with the correction table, the vehicles may not move properly and the system may not perform as expected.

---

**Figure 40 - Straight Track Configuration**

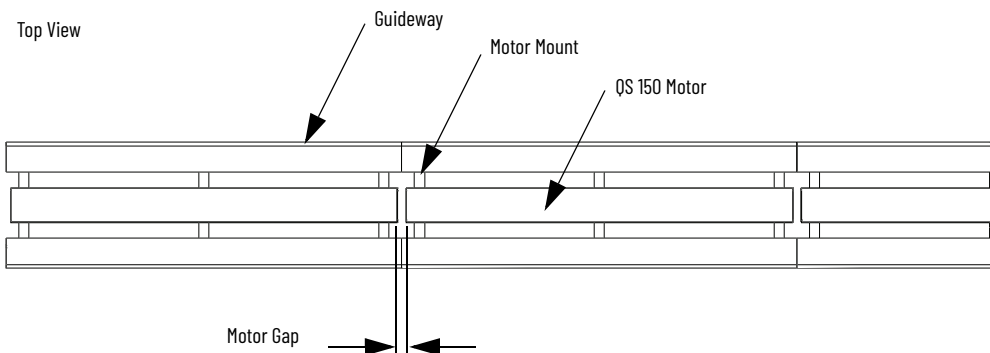

**Figure 41 - Curve Track Configuration**

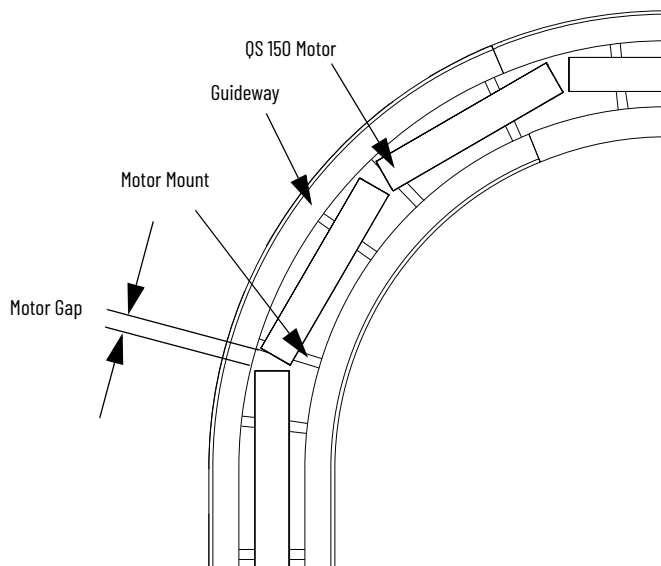





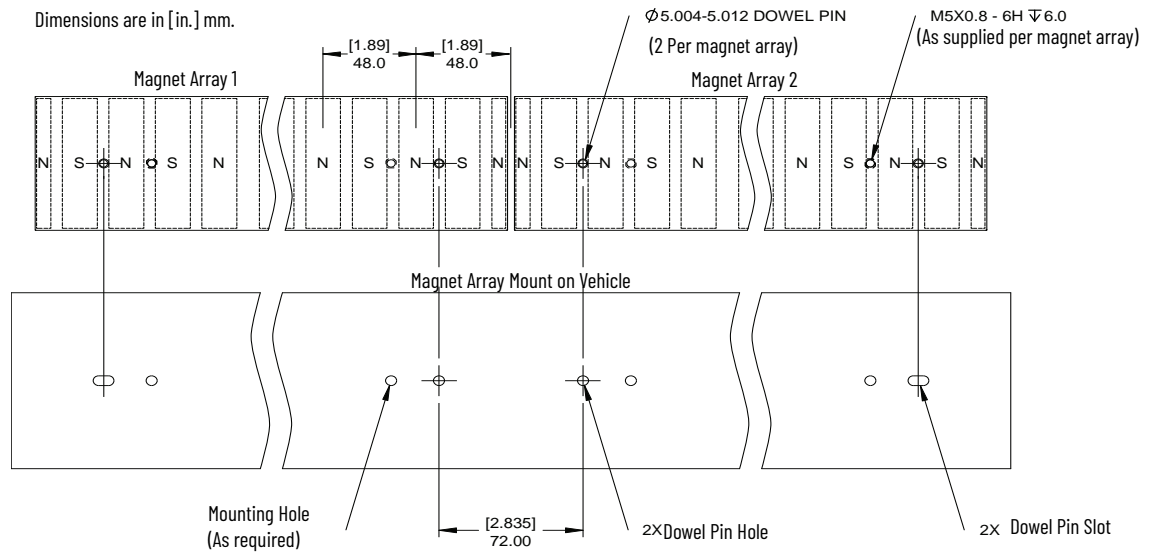

## Magnet Array Installation

Two covered arrays can be placed end-to-end with a minimal gap between the arrays to create longer arrays (for example, two 3 cycle arrays can be used to create a 6 cycle array). When mounting arrays this way, the arrays must be mounted to make sure that all cycles in the combined array measure 48 mm as shown in [Figure 42](#).

Figure 42 - Mounting Two Covered Magnet Arrays End-To-End



 <b>WARNING</b>	
	<b>Strong Magnets</b>
	To avoid severe injury, people with pacemakers and other medical electronic implants must stay away from the magnet arrays.
	To avoid severe injury from strong magnetic attractive forces:
	<ul style="list-style-type: none"> <li>• Handle only one vehicle or magnet array at a time.</li> <li>• Do not place any body parts, such as fingers, between a magnet array and any QuickStick 150 motors, ferrous material, or another magnet array.</li> <li>• Magnet arrays or vehicles not being used must be secured individually in isolated packaging.</li> </ul>
	To avoid damage to watches, instruments, electronics, and magnetic media, keep metal tools, metal objects, magnetic media (for example, memory disks/chips, credit cards, and tapes) and electronics away from the magnet arrays.

The dowel pin holes for the magnet array pins must be 72 mm (2.83 in.) apart from each other (as shown in [Figure 42](#)) to make sure the cycle length remains constant. This sets the correct physical gap between the magnet arrays and is true for any mix of magnet array lengths. For magnet array lengths and dimensions, see [Table 8 on page 37](#).

- The magnet arrays are supplied with threaded holes and locating pins for attaching the array to the mounting surface of the vehicle. The number and location of the mounting holes depends on the size and type of the magnet array. See [Figure 20 on page 38](#) for the magnet array, which includes the mounting hole locations and torques.

Mount the magnet arrays to the vehicles as defined by the design of the vehicle, see the example.

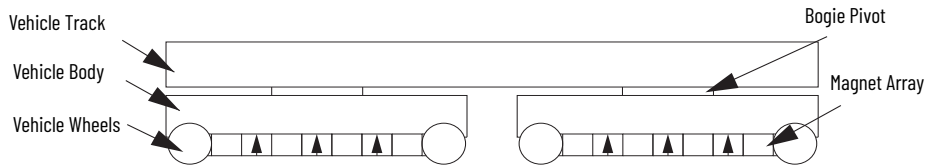

**Figure 43 - Dual-array Vehicle Configuration**



Proper precautions must be taken when magnet arrays with stainless steel covers are used in wash down applications or in environments where water or fluids are contacting the array. The mounting must secure the array with a suitable form of gasket to help prevent water ingress into the array through either its back surface or the seam where the cover meets the back iron of the array. The top surface and sides of the cover are water-resistant.

*Separating Magnet Arrays*

Magnet arrays can become stuck to each other or to any ferrous materials through improper handling. The end-user is responsible to define and implement your own separation procedure. It can be impossible to separate large magnet arrays.

    	 <b>WARNING</b>
	<p><b>Strong Magnets</b></p> <p>To avoid severe injury, people with pacemakers and other medical electronic implants must stay away from the magnet arrays.</p> <p>To avoid severe injury from strong magnetic attractive forces:</p> <ul style="list-style-type: none"> <li>• Handle only one vehicle or magnet array at a time.</li> <li>• Do not place any body parts, such as fingers, between a magnet array and any QuickStick 150 motors, ferrous material, or another magnet array.</li> <li>• Magnet arrays or vehicles not being used must be secured individually in isolated packaging.</li> </ul> <p>To avoid damage to watches, instruments, electronics, and magnetic media, keep metal tools, metal objects, magnetic media (for example, memory disks/chips, credit cards, and tapes) and electronics away from the magnet arrays.</p>

- Only trained personnel must separate magnet arrays that have become stuck to each other.
- If a magnet array is stuck to a surface, slide the magnet array to the edge of the surface, then move the magnet array so that it is in minimal contact with the surface. From this position, you can begin to lift the edge of the magnet array away from the surface edge and off of the surface.



### Mounting A Single Array

When installing one magnet array on one vehicle:

- Work on only one vehicle at a time.
- Make sure that the vehicle is secured to a work surface that is clear of any magnet arrays or ferrous material.
- Move only one magnet array at a time and make sure that the magnet array stays as far away from all other magnets and any ferrous material as possible.

Follow these steps to mount a single magnet array to a vehicle.

1. Locate the magnet array on the vehicle by using the locating features on the magnet array as defined by the design of the vehicle.
2. Secure the magnet array to the vehicle using all provided mounting holes. See [Mounting Magnet Arrays to Vehicles on page 71](#).  
Attach with the M5 mounting hardware, Torque to 30 lb•in (3.39 N•m).
3. Once the array is secured to one vehicle, install one vehicle on the guideway. All other vehicles are installed at a later time.



### Mounting Multiple Arrays

When installing multiple magnet arrays on one vehicle:

- Work on only one vehicle at a time.
- Make sure that the vehicle is secured to a work surface that is clear of any magnet arrays or ferrous material.
- Move only one magnet array at a time and make sure that the magnet array stays as far away from all other magnets and any ferrous material as possible.

Follow these steps to mount multiple magnet arrays to a vehicle.

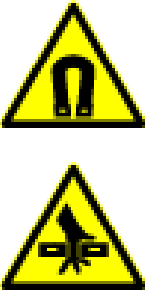
1. Place the first magnet array as described in [Mounting A Single Array](#).
2. Cover the installed magnet array with non-ferrous material (for example, wood) thick enough to shield the attractive force from the magnet array (use a tool such as a steel screwdriver to test).
3. Bring each additional magnet array to the vehicle from the opposite direction of the installed magnet arrays.

	 <b>WARNING</b>
	<p><b>Crush Hazard</b></p> <p>Strong magnets in use.</p> <ul style="list-style-type: none"> <li>• When a magnet array is being installed butted up against the existing magnet array, the existing magnet array repels that magnet array. Being repelled can cause the magnet array to attempt to twist away from the existing magnet array.</li> </ul>

4. Locate the magnet array on the vehicle with the locating features on the magnet array.
5. Secure each additional magnet array to the vehicle as defined by the design of the vehicle. See [Mounting Magnet Arrays to Vehicles on page 71](#).  
Attach with the M5 mounting hardware, Torque to 30 lb•in (3.39 N•m).
6. Once all arrays are secured to one vehicle, install one vehicle on the guideway. All other vehicles are installed at a later time.

## Connecting Motors and Electronics

The electronics for the QS 150 transport system can be attached to the transport system stands or positioned elsewhere in the facility in an appropriate location.

- 
- IMPORTANT** The motors draw additional power when the vehicle is moving or accelerating (see [Table 10](#)). The amount of additional power that is drawn depends on the velocity and acceleration of the vehicle, the number of vehicles accelerating, and the magnet array length.
- All power wiring must be sized to carry the full load and have proper circuit protection.
  - The propulsion power input uses a positive temperature coefficient (PTC) resistor to limit inrush current upon application of power. The PTC is only used for inrush current limiting and is bypassed in normal operation. Limit propulsion power cycling to 40 seconds (30 seconds from on to off and 10 seconds between turn off and turn on). See also [Soft Start on page 82](#).
  - When using separate power sources for logic and propulsion power, the propulsion power and control power returns must be tied to ground.
  - Providing a separate power source for the logic power allows the motors to be programmed and configured without enabling the propulsion power.
- 



**ATTENTION:** Make sure that all mounting surfaces and mounting hardware provide a conductive path to the transport system ground connection.

---

The QuickStick 150 transport system motors can use different network style connection schemes depending on the application. See [Motor Communications: Straight Paths on page 58](#) and [Ethernet Motor Connection on page 60](#). The following procedure provides steps for connecting the motors as shown in the simplified wiring diagrams in [Figure 44 on page 59](#)...[Figure 48 on page 60](#). Power and communication cables must be run such that they are shielded from damage and can be easily accessed for service.

The following procedure provides the information that is required to make all motor connections as shown in [Figure 13 on page 27](#).



**ATTENTION:** Never connect or disconnect the power lines while power is applied to the QuickStick 150 transport system as damage to internal components can result.

---



**ATTENTION:** The node controller and QS 150 motors do not support Power over Ethernet (PoE). Never connect these components to a powered Ethernet network as damage to internal components can result.

---

### *Motor Communications: Straight Paths*

The following figures show simplified connection diagrams of the different methods for connecting a simple string of motors using Ethernet. The specific connection method that is used depends on the application for the motors.

**Figure 44 - Ethernet Motor Wiring - One Path, One Ethernet Chain**

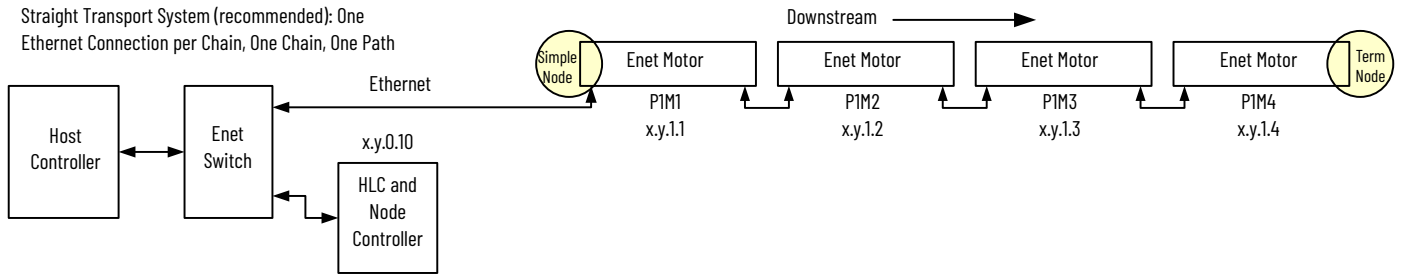

**Figure 45 - Ethernet Motor Wiring - One Path, Two Ethernet Chains**

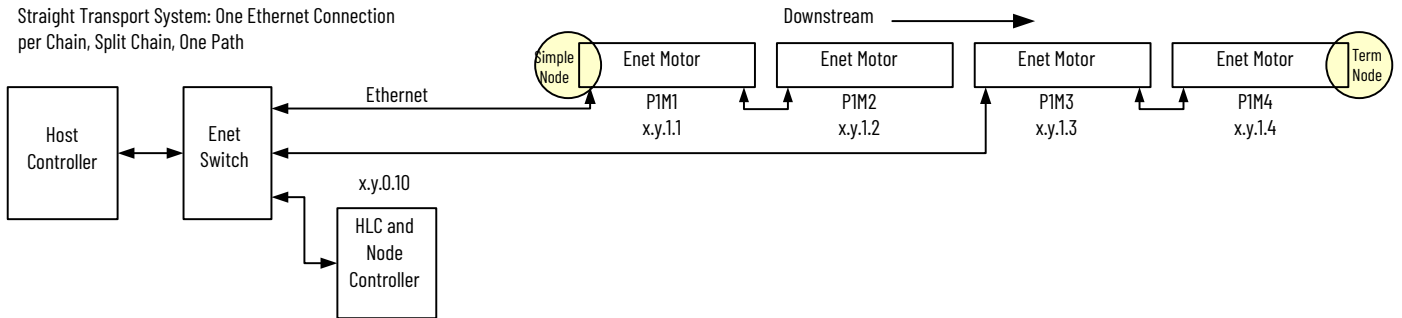

**Figure 46 - Ethernet Motor Wiring - One Path, Ethernet Star**

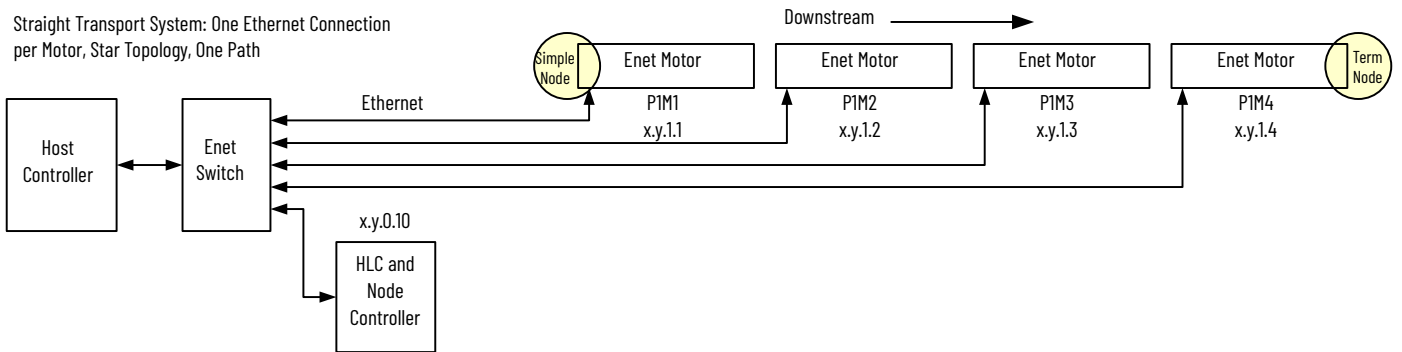

**Figure 47 - Ethernet Motor Wiring - One Path, Ethernet Star, Multiple Ethernet Switches**

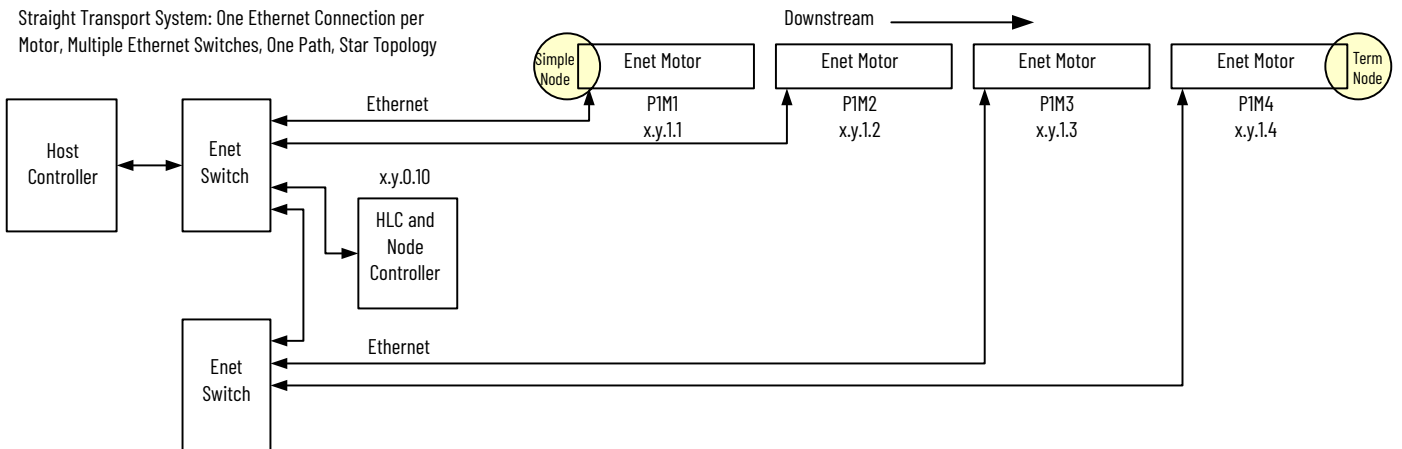
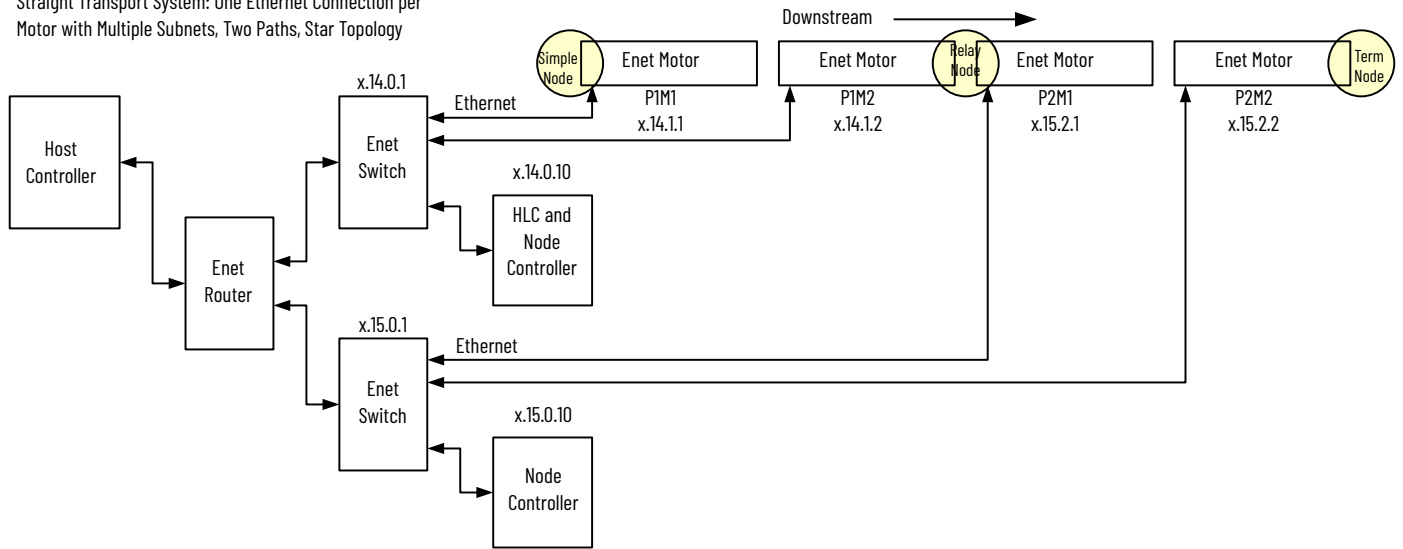

Figure 48 - Ethernet Motor Wiring - Two Paths, Ethernet Star, Multiple Node Controllers

Straight Transport System: One Ethernet Connection per Motor with Multiple Subnets, Two Paths, Star Topology



*Install Motor Communication Cables*

See [Figure 23 on page 41](#) for the communication connection locations on the QS 150 motors and the MagneMotion Node Controller Hardware User Manual, publication [MMI-UM013](#) for the communication connection locations on the node controllers. See [Figure 44...Figure 48](#) for detailed examples of the wiring diagrams.

All motors must communicate with each other via Ethernet. Ethernet motors can be daisy-chained up to 25 motors in a line. See the MagneMotion System Configurator User Manual, publication [MMI-UM046](#) for more information about nodes and paths.

*Ethernet Motor Connection*

When using Ethernet, all motors in a specific path must be on the same network as the node controller. Additionally, all motors and their location in the transport system must be defined in the MICS file, see MagneMotion Node Controller Interface User Manual, publication [MMI-UM001](#).

Figure 49 - Ethernet Communication Connections

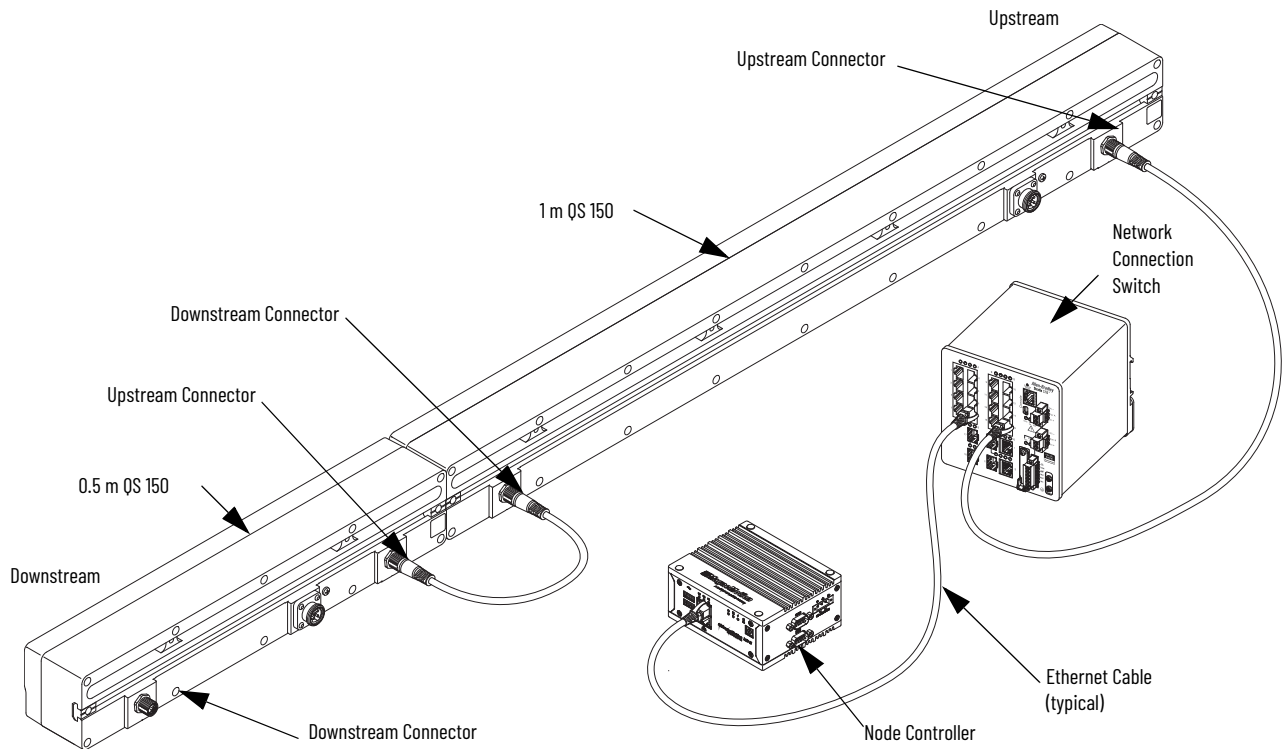

See [Cable Mounting Clearances on page 35](#) and [QuickStick 150 Electrical Specifications on page 39](#) when connecting the power cables to the motors to make sure that each chain of motors does not exceed the rated output of the power supply.

1. Connect the M12 Ethernet connector from first motor in the chain to the Ethernet network switch. Route the cable so it is shielded from damage and can be easily accessed for service, see [Figure 49](#).
2. Connect a communication cable from the communication connector at the downstream end of the motor to the communication connector at the upstream end of the next motor in the path.
3. Continue to connect the remaining motors in the path with the communication cables.
4. Record the node controller IP address from the transport system layout and the port number from the node controller for entry into the Node Controller Configuration File.
5. Repeat [step 1](#) through [step 4](#) for each path in the QS 150 transport system.



The motors at the ends of all paths that are owned by the same node must be connected to the same node controller.

6. Use nylon cable-ties, cable channels, and cable lacing cord to bundle and arrange all cables as required to keep all cable routing clean.
7. See MagneMotion QuickStick and QuickStick HT Design Guide, publication [MMI-RM001](#) for external communication connections and the MagneMotion Node Controller Hardware User Manual, publication [MMI-UM013](#) for the communication connection locations.

### Install Motor Power Cables

See [Figure 23 on page 41](#) for the power connection locations on the QS 150 motors in the QuickStick 150 transport system. See [Figure 44...Figure 48](#) for simplified diagrams of the wiring. [Figure 50](#) shows the power connections being made to the bottom of the motor.

**Figure 50 - Power Connections: Two Motors**

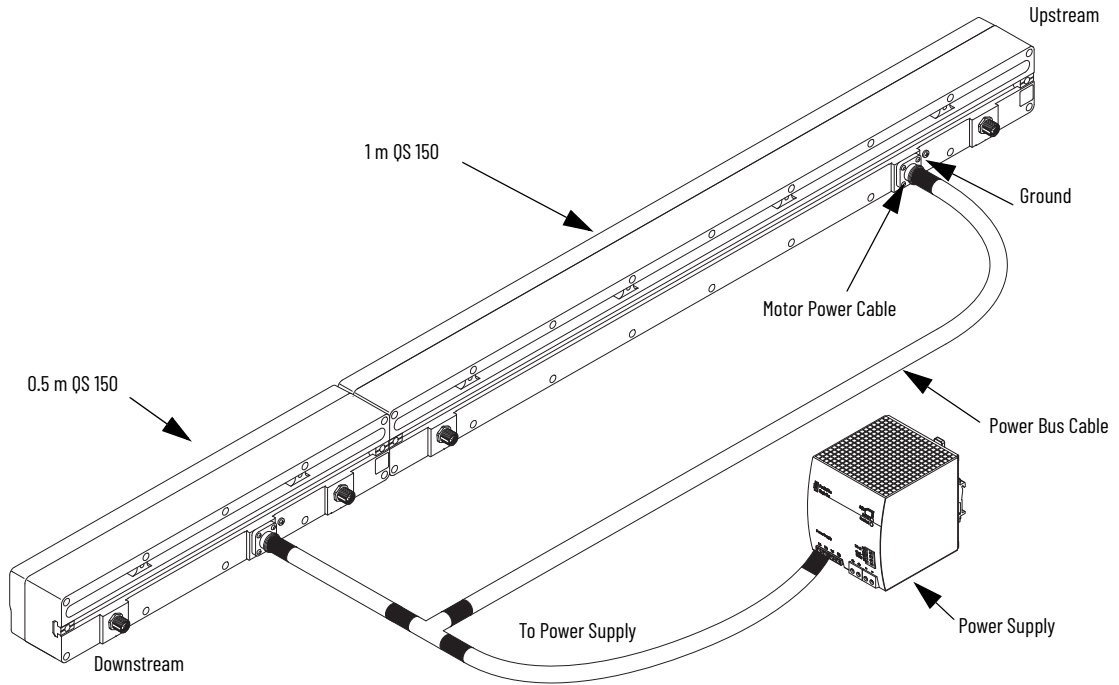

**Figure 51 - Power Connections: Two or more Motors in a Chain**

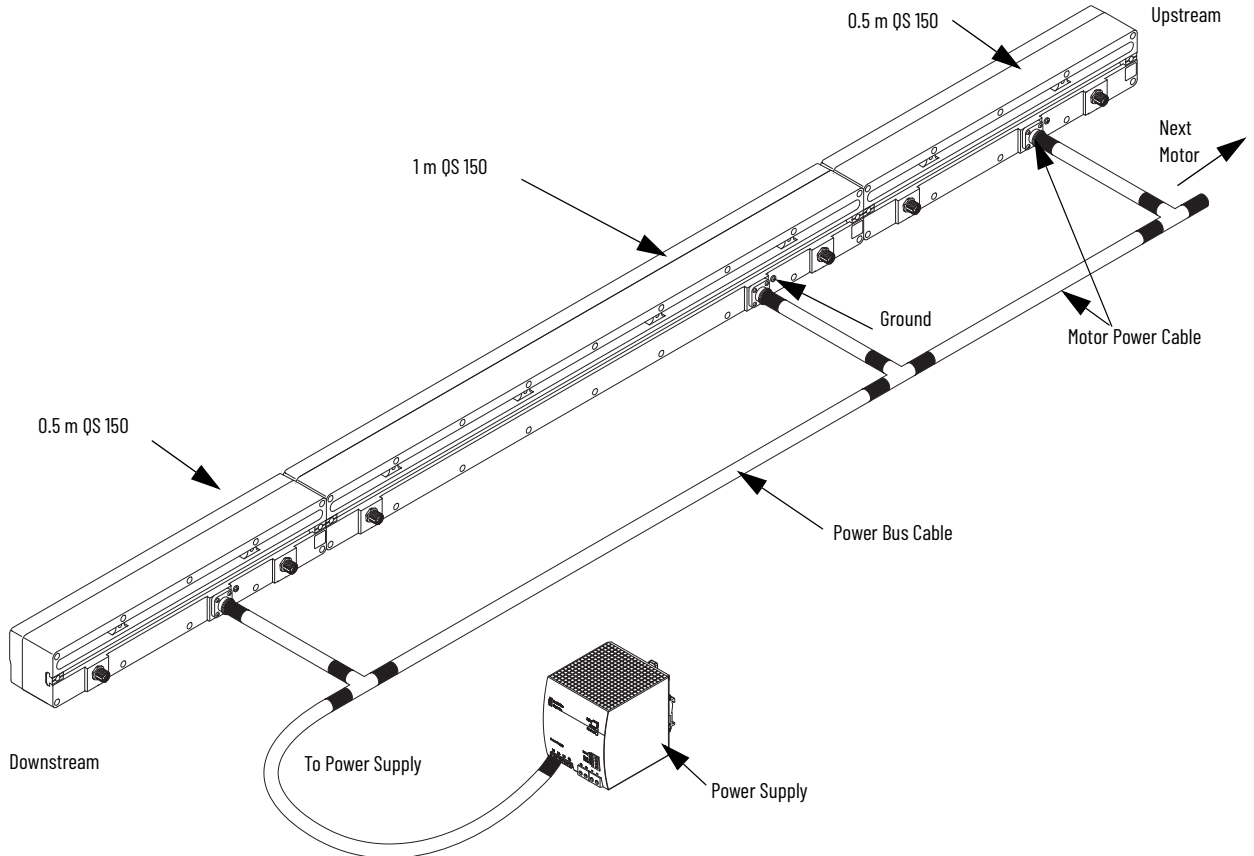



**ATTENTION:** If a user-supplied power supply is used, it must be NRTL/ATL approved.

**Figure 52 - QuickStick 150 Motors Orientation**

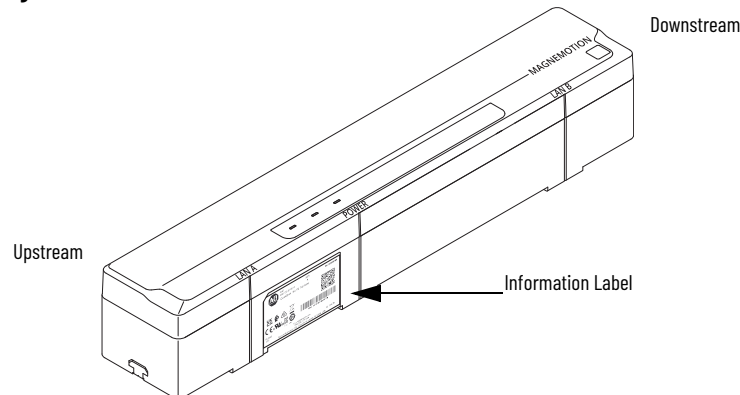

1. Connect the power cable (pigtail) to the terminals on the power supply.
  - Make sure that the power supply is properly grounded.
  - Make sure that the power cables are sized for the full load of all motors downstream from the connection.
2. Connect the other end of the power cable to the tee cable for the first motor.
3. Connect the drop cable from the tee cable to the first motor.
4. Connect a trunk cable from the tee of the first motor to the tee of the next motor. See [Figure 51](#).
5. Repeat [step 2](#)...[step 4](#) for all motors in the chain.



It is not necessary to connect all motors on a path to the same power supply or to connect a power supply to only one path.

6. Attach the end cap to the last connection cable in the line.
7. Connect the ground stud on all motors to GND (PE).
8. Use nylon cable-ties, cable channels, and cable lacing cord to bundle and arrange all cables as required to keep all cable routing clean.
9. See [Facilities Connections](#) for external power connections.
10. Perform [Check-out and Power-up on page 63](#) and verify all operating features, safety features, and connections.
11. After completing [step 10](#), proceed to installing the [Software on page 66](#).

## Facilities Connections

The standard configuration of the QuickStick 150 transport system requires user-supplied electrical power and communication connections. See the MagneMotion QuickStick and QuickStick HT Design Guide, publication [MMI-RM001](#) for descriptions and specifications of all required facilities.

## Check-out and Power-up

### System Check-out

Before the QuickStick 150 transport system is started for the first time, or after servicing the transport system, it is necessary to check all operating and safety features.

The following startup procedure is used to apply power to the QuickStick 150 transport system in an orderly manner to make sure that all components are in known states. This procedure is used to prepare the transport system for full operation.

#### Mechanical Checks

- Verify that all shipping brackets have been removed.
- Make sure that all QuickStick 150 components are properly and securely installed in the facility.
- Make sure that all hardware is secure.
- Manually move a vehicle through the entire QS 150 transport system to verify free vehicle motion (no binding). [Moving Vehicles by Hand on page 72](#) for additional information.

#### Facility Checks



- Make sure that all facilities meet, or exceed, the requirements as described in the MagneMotion QuickStick and QuickStick HT Design Guide, publication [MMI-RM001](#) and [Table 10 on page 39](#).
- Make sure that all system power and communication connections have been completed.
- Check all cables. Verify that the connectors are fully seated and screws/locks are secured to make sure of good continuity.
- Verify that all cables are routed so they are shielded from damage and can be easily accessed for service and are away from any travel areas.
- Inspect all cables for restricting bend radii, excessive tension, or physical damage.



#### Pre-operation Checks

- Make sure that there are no obstructions in the travel path of the vehicles.

### System Power-up



After the QuickStick 150 transport system has been installed, all connections must be checked. If all connections are secure, an initial power-up must be performed before proceeding any further with the installation process. This section provides the procedure for the initial installation power-up.

	 <b>WARNING</b>
	<p style="text-align: center;"><b>Crush Hazard</b></p> <p>Moving mechanisms (vehicles) have no obstruction sensors. Do not operate the QuickStick 150 transport system without barriers in place or personal injury could result in the squeezing or compression of fingers, hands, or other body parts between moving mechanisms.</p>



	 <b>WARNING</b>
	<p style="text-align: center;"><b>Automatic Movement</b></p> <p>Whenever power is applied, the possibility of automatic movement of the vehicles on the QuickStick 150 transport system exists, which could result in personal injury.</p>



1. Make sure that all installation procedures that are previously described in this chapter have been completed.
2. Make sure that the system is properly grounded.
3. Connect the QS 150 transport system to the electrical services for the facility. Make sure that the power remains off.

	 <b>CAUTION</b>
	<p><b>High Voltage Hazard</b></p> <p>Cabling should be sized and protected to support the maximum power draw for the number of vehicles and motors that are supplied power by that cabling. Make sure the AC circuit supplying power to the power supplies for the motors is properly sized and properly protected.</p>

4. Perform a ground continuity check from the surfaces of the QS 150 transport system, including the vehicle, to a known good ground.
5. Apply power to the QuickStick 150 transport system.

	 <b>WARNING</b>
	<p><b>Automatic Movement</b></p> <p>The host controller is responsible for all QS 150 transport system motion. It is the responsibility of the user to initiate a safe startup of all QS 150 components.</p> <p>Do not attempt to operate the QS 150 transport system until all setup procedures that are described in this chapter have been completed.</p>

[Table 17](#) provides descriptions of the QS 150 motor status indicators.

**Table 17 - Motor Status Indicators**

Condition	Power	Network	Module
Steady Off	There is no power applied to the motor module section.	There is no power applied to the motor module section or the IP address is not configured.	There is no power applied to the motor module section.
Steady Green	Motor is operational. No power faults or failures. The motor has expected propulsion applied to the motor module section.	Node controller connection is established and normal operation. IP address is configured.	Motor is operational. No motor faults or failures.
Flashing Green	Propulsion power is not within acceptable limits. Example: Under-voltage fault, Soft Start not complete.	Motor has not been provisioned with IP address.	Motor is in stand by mode. Example: Suspended / Fast Stop by the node controller.
Steady Orange	The motor has triggered an under/over voltage warning.	—	Degraded performance. Example: Motor stall detected and/or Hall Effect sensor fault, under/over voltage warning.
Flashing Orange	—	—	—
Steady Red	Non-recoverable power fault - fuse open. Motor has Propulsion power but no Logic Power.	Duplicate IP address. The IP address specified is already in use.	Major fault. The motor module section detected a non-recoverable fault. Example: Latched faults including over-current, board communication fault, or fuse fault.
Flashing Red	Over-voltage fault.	Connection timeout. No connection to node controller.	Major recoverable fault. The motor module section detected a recoverable fault. Example: Over temperature, under/over voltage fault.
Flashing Green/Orange	—	—	—
Flashing Green/Red	—	—	The motor section is powering up and/or performing initiation tasks. Example: Programming, boot loader mode.
Flashing Orange/Red	—	—	—
NET & MOD Alternating flashing red	Firmware update in progress. Control power should not be removed during this condition.		

- If power-up was successful, the QuickStick 150 transport system is ready to accept commands. If however, the power-up sequence was unsuccessful, see [Troubleshooting on page 95](#).
- Program the controllers and drivers for the motors. See the MagneMotion Node Controller Interface User Manual, publication [MMI-UM001](#) for details.

## Software

All QuickStick 150 motors ship with just a basic software image installed. This image is used for testing during manufacturing and must not be used to run the motors as part of a transport system. Since different systems run different versions of the software, this basic software must be replaced with the software being used for the transport system.

The QuickStick 150 transport system requires user creation of the Node Controller Configuration File and creation of host controller software to direct

vehicle movement for the particular application and to monitor transport system performance. See the MagneMotion Node Controller Interface User Manual, publication [MMI-UM001](#) for details.

Upgrades to the software can be uploaded through the network communication link. See the upgrade procedure in the release notes supplied with the software upgrade.



Specific builds of the software may not implement all features that are described in this manual. See the release notes that are provided with the software for additional information.

All software running on the QuickStick 150 transport system must be part of the same release. See the release notes that are provided with the software for additional information.

Only qualified Rockwell Automation® personnel or personnel that are directed by Rockwell Automation should make alterations or changes to the software.

The Node Controller Configuration files must be uploaded to each node controller in the transport system before operation. See these publication for details:

- MagneMotion System Configurator User Manual, publication [MMI-UM046](#)
- MagneMotion Node Controller Interface User Manual, publication [MMI-UM001](#)

Configure the host controller to control the transport system for additional information.

- MagneMotion Host Controller TCP/IP Communication Protocol User Manual, publication [MMI-UM003](#)
- MagneMotion Host Controller EtherNet/IP Communication Protocol User Manual, publication [MMI-UM004](#)

## Motor Software Installation

1. Upload the Motor ERF Image files (*motor\_image.erf*) to each node controller with the node controller web interface and program the motor controller and driver. See [Programming Replaced Motors on page 91](#) and the MagneMotion Node Controller Interface User Manual, publication [MMI-UM001](#) for details.





Restart the node controller for the changes to take effect.

2. Reset the paths where the motors were programmed (for example, use the NCHost TCP/IP Interface Utility). See the MagneMotion NCHost TCP/IP Interface Utility User Manual, publication [MMI-UM010](#) for details.



## System Testing

Test the QuickStick 150 transport system to verify proper operation of all nodes, paths, and vehicles. Testing can be accomplished using the NCHost application to move vehicles without the host controller to verify proper operation before integrating a transport system into a production environment.

To perform repetitive testing throughout the transport system, see the MagneMotion NCHost TCP/IP Interface Utility User Manual, publication [MMI-UM010](#), and MagneMotion Node Controller Interface User Manual, publication [MMI-UM001](#), for details. If any problems are encountered, see [Troubleshooting on page 95](#).

	 <b>WARNING</b>
	<p style="text-align: center;"><b>Crush Hazard</b></p> <p>Moving mechanisms have no obstruction sensors. Do not operate the QuickStick 150 transport system without barriers in place or personal injury could result in the squeezing or compression of fingers, hands, or other body parts between moving mechanisms.</p>







1. Make sure that the transport system is fully configured.
2. Make sure that the Node Controller Configuration File is fully defined and has been uploaded to all node controllers.
3. Make sure that the web interface for each node controller shows a status of running/valid.
4. Issue a Restart Services command for each node controller.
5. Issue a Reset command for all paths.  
All motors on the paths in the transport system are reset.
6. Issue a Startup command to all paths.  
Motion on all paths is enabled, all vehicles on the paths are identified and located, and the paths become operational.

	 <b>WARNING</b>
	<p style="text-align: center;"><b>Crush Hazard</b></p> <p>The vehicles may move during the startup sequence.</p>

7. Verify that the host controller has identified all vehicles in the transport system. See [Motor Operation on page 76](#) for additional information.
8. Move vehicles individually or create a Demo Script for repetitive testing.
9. Monitor transport system operation with the NCHost TCP/IP Interface Utility.

## Vehicle Installation

Vehicles can have one or two magnet arrays that are attached to the surface closest to the motors based on the use of the vehicle and the design of the guideway. Typically, when vehicles travel guideways with curves, they have two independent magnet arrays to help maintain maximum alignment of the arrays with the motors, while traveling through the curve.

    	 <b>WARNING</b>
	<h3>Strong Magnets</h3> <p><b>WARNING:</b> To avoid severe injury, people with pacemakers and other medical electronic implants must stay away from the magnet arrays. To avoid severe injury from strong magnetic attractive forces:</p> <ul style="list-style-type: none"> <li>• Handle only one magnet array at a time.</li> <li>• Do not place any body parts, such as fingers, between a magnet array and any QuickStick 150 motors, ferrous material, or another magnet array.</li> <li>• Magnet arrays not being used must be secured individually in isolated packaging.</li> </ul> <p>To avoid damage to watches, electronic instruments, and magnetic media (for example, cell phones, memory disks/chips, credit cards, and tapes), keep these items far away from the magnet arrays.</p>

- Vehicles must be grounded to the guideway through conductive materials such as wheels, skids, or static brushes.
- The vehicle must have low friction with the guideway.
- All vehicles on connected guideways must be the same size and use the same size and type of magnet array.

**Figure 53 - Typical Vehicle on Guideway**

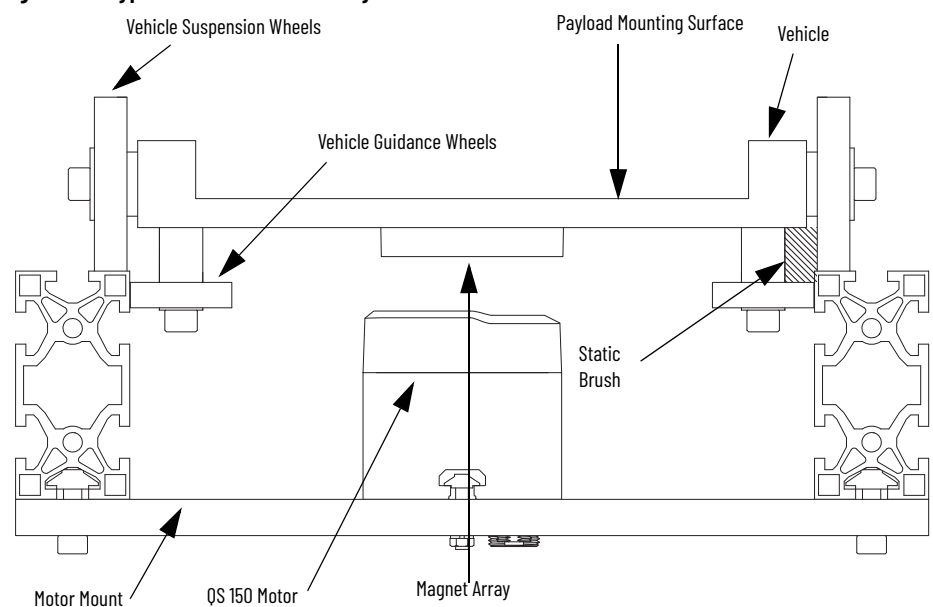

Wheel and roller materials affect the frictional resistance, which affects the amount of thrust that is required to move a vehicle. The selected material must be hard enough to provide a low rolling resistance but, depending on the environment the system is used in, soft enough to minimize excess noise when traversing the joints between guideway sections.

**Figure 54 - Single Array Vehicle Configuration**

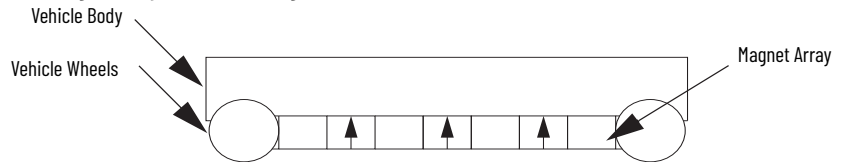

**Figure 55 - Dual-array Vehicle Configuration**

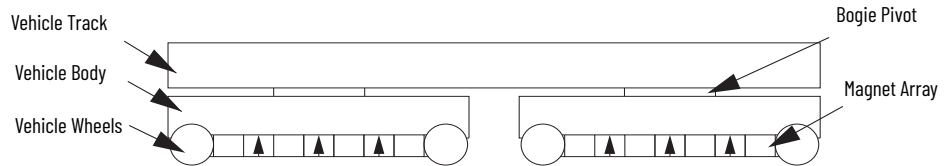

### Vehicle Gap

The vehicle gap, which is shown in [Figure 56](#), is the distance that is maintained between the magnet array and the QS 150 motor. This gap must be maintained throughout the transport system to make sure that the vehicle operates consistently. The larger the gap the longer the magnet array must be to achieve the same thrust. The smaller the gap the greater the risk of contact between the magnet array and the top of the motor, which could cause damage to the motor or magnet array.

**Figure 56 - Vehicle Gap**

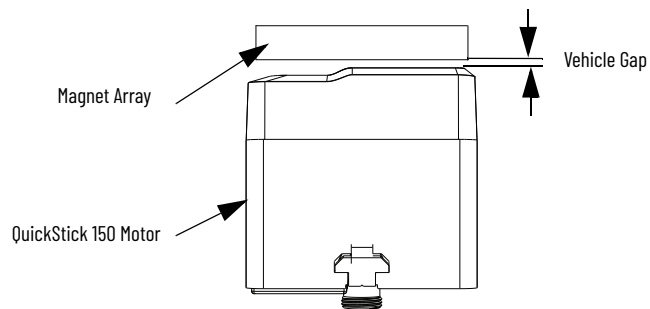

The vehicle gap must be such that any deviation in the flatness of the vehicle suspension surface does not allow the magnet array on the vehicle to touch down on either the suspension surfaces or the motors. See MagneMotion QuickStick and QuickStick HT Design Guide, publication [MMI-RM001](#), for additional information on vehicle gaps and single or dual-array vehicles.

The recommendations for the vehicle gap when using QS 150 magnet arrays that are shown are for reference only. Using a smaller minimum vehicle gap or a larger maximum vehicle gap is possible. However, exceeding the vehicle gap recommendations typically requires special design considerations and can make it difficult for the position sensors in the motor to locate the vehicles precisely. [Rockwell Automation Support](#) for additional information.

- Minimum vehicle gap is 1 mm.
- Nominal vehicle gap is 3 mm for typical industrial applications.
- Maximum vehicle gap is 10 mm.

## Mounting Magnet Arrays to Vehicles

Magnet arrays are provided with locating features to provide consistent mounting to the vehicles and threaded holes for attachment. Arrays must be attached using stainless steel hardware that fully engages the threads in all magnet array mounting holes as shown in [Figure 57](#).

**Figure 57 - Magnet Array Mounting**

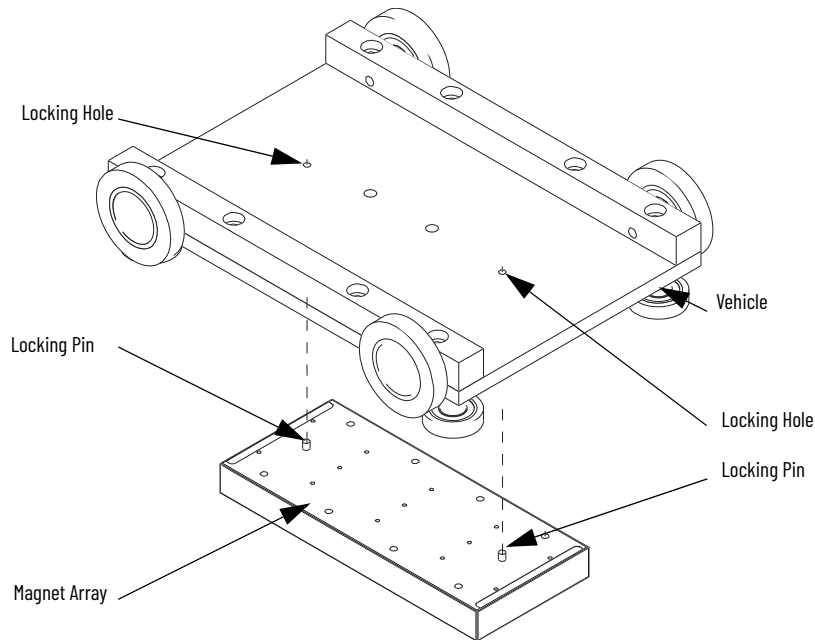

Vehicles can be added or removed as needed once the QuickStick 150 transport system is installed.



The design of the guideway and of the vehicle determines the ease of adding vehicles. That is, an open guideway allows vehicles to be placed onto it, while a closed guideway requires either an opening for placement of vehicles or placement of the vehicles before closing the guideway.



It is recommended that vehicles are pushed in from the end of the motor, not placed down on top of the motor to reduce risk of crushing hazard. See [Figure 58](#).

**Figure 58 - Recommended Vehicle Installation**

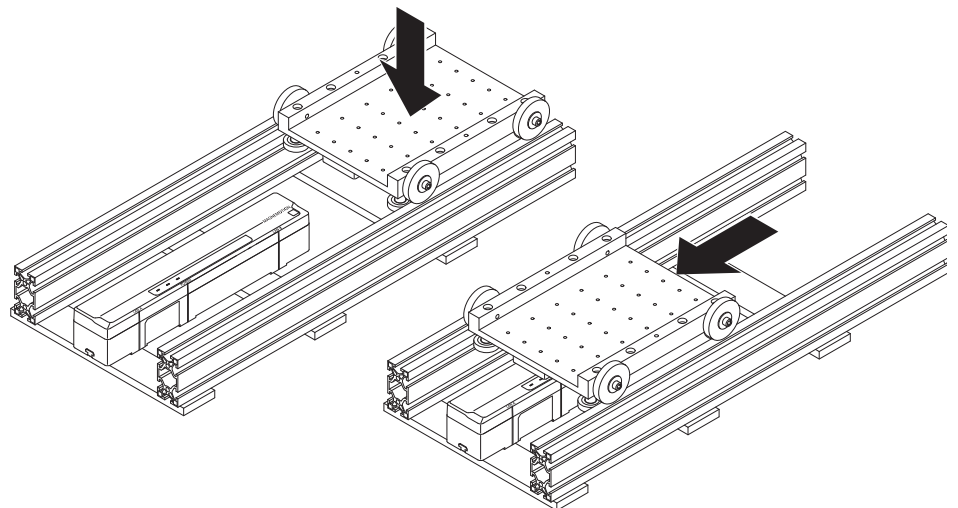



The QuickStick 150 motors do not compensate for the amount of thrust that is lost when the magnet array is over the downstream gap. This means that if the array only has half coverage, the effective PID values, and peak thrust are halved, and the system does not perform as it would with full coverage.

### Moving Vehicles by Hand

Only move vehicles on the QuickStick 150 transport system using the QS 150 motors in the system. If there is an event that requires moving the vehicles by hand, the guidelines that are provided here must be followed.

	<b>WARNING</b>
	<p style="text-align: center;"><b>Crush Hazard</b></p> <p>Moving mechanisms have no obstruction sensors. Do not attempt to move any vehicles manually while propulsion power is supplied to the transport system or personal injury could result in the squeezing or compression of fingers or other body parts between moving mechanisms.</p>

	<b>CAUTION</b>
	<p style="text-align: center;"><b>Electrical Hazard</b></p> <p>Moving vehicles by hand produces eddy currents in the stators of the motors where the vehicle is being moved, which puts power on the propulsion bus.</p>

If both propulsion power and logic power to the transport system are removed, vehicles are not tracked. Once power is restored, the transport system must be restarted, which detects all vehicles at their current locations.

If propulsion power to the transport system is removed while logic power is maintained and a vehicle is moved manually on the motor, the transport system tracks its position. If the center of the magnet array on the vehicle crosses a motor boundary (moves off the end of a motor), it creates an Unlocated Vehicle Fault. Vehicles that have crossed a motor boundary are said to have lost their signal (Vehicle Signal = 0) when monitoring the vehicle status through the Host Communication Protocols.

See either the MagneMotion Host Controller TCP/IP Communication Protocol User Manual, publication [MMI-UM003](#) or the MagneMotion Host Controller EtherNet/IP Communication Protocol User Manual, publication [MMI-UM004](#) for additional information.

A vehicle that has been manually moved, bumped, or dislodged, and lost its signal, is able to reacquire its signal when it is manually relocated to within approximately 25 mm of its original position as measured from the center of the magnet array in a vehicle or the mid-point between arrays in a tandem vehicle. When propulsion power returns, the vehicle is not able to move unless it had been returned to the same section of the motor where it was located when the power was shut off. In this case, the vehicle is shown as having signal (Vehicle Signal = 1) but it also shows as Suspect. Vehicles that are identified as Suspect require a restart of the path where they are located to clear the Suspect bit. In some cases, the vehicle can be commanded, but it continues to show as Suspect.





The vehicle IDs for all vehicles on a path that is reset are not maintained. That is, a vehicle can be assigned a vehicle ID different from the ID it had before the path was reset.

If both propulsion power and logic power are maintained and a vehicle is moved manually, the motor resists motion of the vehicle. Once the vehicle is released, it snaps back to its original position if it has not been moved more than 25 mm, unless the center of the magnet array on the vehicle crossed a motor boundary.

Vehicles that have been moved too far can be recovered by deleting the moved vehicles and restarting the section of the transport system where they are located to detect them.

**Notes:**

## Operation

An advantage of the QuickStick® 150 transport system is that the motor secondary (vehicle) is not connected or tethered to the motor primary. This configuration allows the vehicle to travel further and faster than connection cables allow. Another advantage is unlimited travel length. The result is a propulsion solution with excellent reliability that is efficient, quiet, and clean.

## Motion Control

The QuickStick 150 transport system provides an integrated transport system for material movement along one axis. Motors are linked together in paths that define the individual motion routes. The host controller can then direct the motion and position of the vehicles anywhere along the length of the path. Vehicles can also be moved from one path to another as long as there is a connection between the paths (either direct or through one or more other paths) through a node (or multiple nodes).

The design and operation of the QuickStick 150 transport system uses a minimum of moving parts to minimize maintenance requirements. Position sensors in all motors make sure that there is accurate tracking and positioning of all vehicles in the transport system.

## Motor Topology

Each QuickStick 150 motor is constructed as a series of blocks, see [Table 4 on page 21](#) and [Figure 59](#) and [Figure 60](#). Each block is a discrete motor primary section within the motor consisting of multiple coils that is energized as required. Varying the magnetic force within a block and its neighbors causes the vehicle to move in the desired direction and provides precise positioning of the vehicles.

The control software makes sure that the minimum distance between vehicles at the extreme ends of adjacent motor blocks is 6 mm (0.26 in.) when not moving. However, this dimension is variable depending upon the vehicle edge location relative to the block boundary. This feature allows having a magnet array (vehicle) right justified in the first block of a QuickStick 150 motor with a second magnet array (vehicle) left justified in the second block of the QuickStick 150 motor. The anti-collision feature in the QuickStick 150 motors keeps two vehicles from occupying the same motor block.

**Figure 59 - Representation of Stationary Vehicles Per Motor Block**

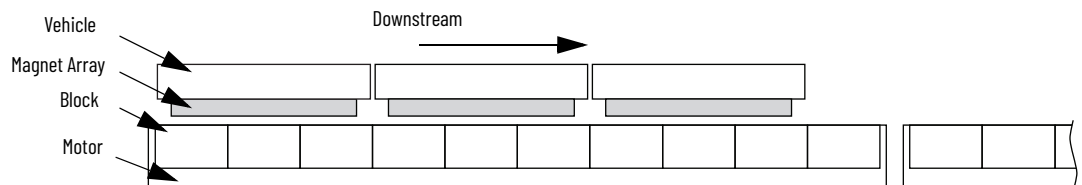

**Figure 60 - Representation of Moving Vehicles Per Motor Block**

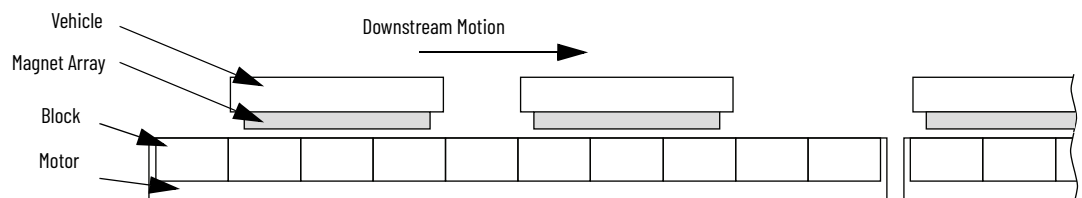

## Motor Operation

The QuickStick 150 motors provide asynchronous control of vehicles on the transport system as directed by the host controller. This control method minimizes the load on the host controller with the node controllers and motors performing all routing and vehicle control operations (positioning, acceleration, deceleration, and collision avoidance) as described in the following sequence.

1. The host controller generates an asynchronous motion order to move a vehicle to a specific location and sends it to the high-level controller (HLC) using either a position or station command. Locations are always defined from the beginning of a path.  
For example, the Order is to move Vehicle #1 to a Position 1.5 m on path 1 ( $P_{dest}$ ) at a maximum speed of 0.5 m/s ( $V_{max}$ ), and acceleration/ deceleration of  $1 \text{ m/s}^2$  ( $A_{max}$ ).
2. The HLC routes the order to the appropriate node controller.
3. The node controller generates a motion order and sends it to the appropriate vehicle motor controller for the motor where the vehicle is located.
4. The vehicle motor controller generates a motion profile that is based on the order. Every update period ( $\sim 1 \text{ ms}$ ) a new position, velocity, and acceleration setpoint ( $P_{set}$ ,  $V_{set}$ , and  $A_{set}$ ) are calculated.
  - As the vehicle moves, the motor controller acquires empty blocks ahead of the vehicle that the vehicle can move into based on the current motion order for the vehicle. A 'block' is defined as an independently controlled set of coils, see [Table 4 on page 21](#) for details. No two vehicles are allowed to occupy the same block.
  - The vehicle motor controller uses the position of the most recently acquired block farthest from the vehicle as an interim destination (target) to calculate the next profile setpoint ( $P_{set}$ ,  $V_{set}$ , and  $A_{set}$ ).
  - The vehicle motor controller handles all collision avoidance to make sure brick-wall headway is maintained between vehicles.
5. The vehicle motor controller uses the profile setpoints as inputs to control the vehicle position.  
During the move, vehicle data such as actual position, velocity, and interim destination are sent back to the node controller, typically every 100...200 ms. This data provides the host controller some level of feedback as to where the vehicle is located.
6. The vehicle motor controller continues to generate updated motion profiles that are based on the order and vehicle control continues based on the new profile setpoints. This updating continues until the vehicle is handed off to the next vehicle motor controller or it reaches its destination.  
The vehicle motor controller hands-off vehicle control to the motor controller in the next motor as the vehicle moves across motor boundaries. The new motor controller 'picks up' where the old one left off for profile generation. The new motor controller is now responsible to continue the closed-loop control of the vehicle.
7. The motion order is finished when the vehicle position is equal to the ordered destination.

## Motor Cogging

Brushless Permanent Magnet (BPM) motors that are iron core-based inherently exhibit cogging forces. In traditional BPM motors, these cogging forces are felt when turning the shaft of the motor and are periodic in nature. The periodicity in this case would be expressed in degrees and the magnitude and direction of this cogging force would vary as a function of shaft position.

Linear motors, such as the QuickStick 150 motors that use an iron core to maximize thrust (equivalent to torque in a traditional rotary motor) also exhibit cogging forces. The main difference between rotary motors and linear motors is that in linear motors these forces are periodic as a function of distance versus angle. In the linear motor, these forces tend to pull the vehicle forward or backward at specified intervals along the motor.

The QS 150 motors are designed to minimize cogging as the vehicles travel over the motor. Vehicles are subjected to slightly greater cogging as they travel from motor to motor. The frequency of these cogging forces is directly proportional to vehicle speed. Cogging forces are below 5% of the available thrust that is provided by the motors and do not appreciably impact the acceleration and speed capabilities of the motors. However, cogging can lead to perceptible low-level vibrations whose frequency are related to vehicle speed. These small vibrations have a typical frequency range of 0 Hz (at zero speed) to 30 Hz (at high vehicle speeds).

For general transport and conveyance applications, cogging effects are not observable or perceptible if the vehicle, track, and payload design do not exhibit a sharp resonance within the 0...30 Hz range. However, for payloads susceptible to vibration, these cogging effects can have an impact and require special attention to suppress them. See the MagneMotion QuickStick and QuickStick HT Design, publication [MMI-RM001](#) for installation methods to minimize cogging.

## Motor Blocks

A motor block is a discrete motor section within each QuickStick 150 motor as shown in [Figure 59](#) and [Figure 60](#). Each block is a set of independently controlled copper windings that are driven by one inverter, with multiple blocks creating the motor primary (stator). Each of the copper windings has an iron core, which creates an attractive force between the magnet array and motor even when the motor is not powered.

### Block Acquisition

The motor controller for each motor takes ownership of vehicles when they enter the motor or are identified during startup and maintains that ownership the entire time the vehicle is on the motor. Ownership includes identification of the final destination, maximum acceleration, and maximum velocity as defined in the current motion order and determination of the interim destination for the vehicle and current acceleration and velocity setpoints.

The motor controller makes sure that the vehicle has acquired sufficient empty blocks ahead of the vehicle in the direction of motion to maintain brick-wall headway with the current motion profile. The vehicle is said to own these blocks until they are released. Headway is maintained by communicating with the motors ahead of the vehicle to make sure that sufficient blocks can be acquired to define new interim destinations.

- The vehicle motor controller uses the position of the most recently acquired block farthest from the vehicle as an interim destination (target) to calculate the next profile setpoint ( $P_{set}$ ,  $V_{set}$ , and  $A_{set}$ ).
- A new interim destination (target) block is only granted if the block has not been allocated to another vehicle (that is, permission is granted for only one vehicle per motor block).
- A new target is requested only immediately before the vehicle must start slowing down for its current target to minimize the number of committed blocks and to make sure brick-wall headway is maintained.
- Permission to enter a motor block is only granted after the previous vehicle has exited the block and released ownership.
- Each vehicle is controlled in such a manner that it is always able to stop in the last motor block it was granted permission to enter.

## Block Ownership

The minimum distance two vehicles can be from each other is 6 mm, since the end of each vehicle maintains a space of 3 mm from the end of the owned motor block in the direction of motion for anti-collision. This minimum distance is based on the length of the vehicle, not the magnet array. [Figure 61](#) shows that when any portion of a vehicle is over a motor block, the vehicle owns that whole block. The vehicle positions in [Figure 61](#) show that the vehicles could be closer together, but vehicle separation is based on the length of the configured payload or vehicle and block ownership, not the length of the magnet array.

When vehicles are placed in queue, they get as close to their commanded position as possible without violating the block boundaries as shown in [Figure 61](#). When trying to create stations that put vehicles next to each other, the vehicle positions and the space that a vehicle occupies in a motor block must be considered, as shown in [Figure 61](#).

**Figure 61 - Representation of Block Ownership by Vehicle**

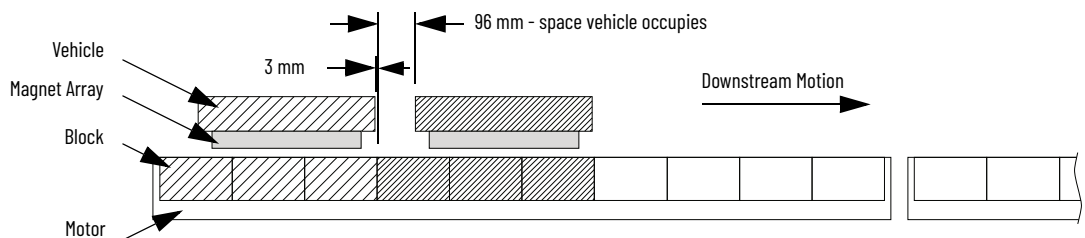

## Block Release

The motor controller for each motor releases ownership of blocks once the vehicle exits the block and is at least 3 mm away from that block. Block ownership is also released if the vehicle is deleted.

## Anti-Collision

The QuickStick 150 transport system allows only one vehicle per motor block. This block allocation is the basic rule on which the anti-collision feature of the QS 150 transport system controls is founded. Since two vehicles are not allowed to be in the same motor block, they cannot collide. This block allocation affects how many vehicles can fit on a motor or path.

Also, the vehicle magnet arrays have a slight repulsive force that causes them to passively separate by a short distance when they are manually pushed together and not being actively controlled. The distance they passively separate varies based on vehicle and guideway conditions (including friction).

The vehicles can be commanded to a tighter spacing but this spacing requires constantly driving the motor to force them together. They can be commanded to a pitch where they are practically in contact with each other, but if this constant, close position condition is held too long, the motors reach a thermal limit and shut down. This tight spacing can be done on occasion but it cannot be a standard part of a process.

## Safe Stopping Distance

Standard vehicle control makes sure that vehicles always have a safe stopping distance (brick-wall headway). [Figure 62](#) shows acceleration, velocity, and position versus time for the standard vehicle motion profile. Permission for vehicle motion is granted as required for the vehicle to maintain its motion profile (solid heavy line) and provide brick-wall headway (dashed heavy line) based on the current velocity and commanded acceleration of the vehicle. The brick-wall headway distance can be found by dividing the square of the current velocity of a vehicle by twice its acceleration [ $V^2/(2a)$ ].

**Figure 62 - Vehicle Motion Profile**

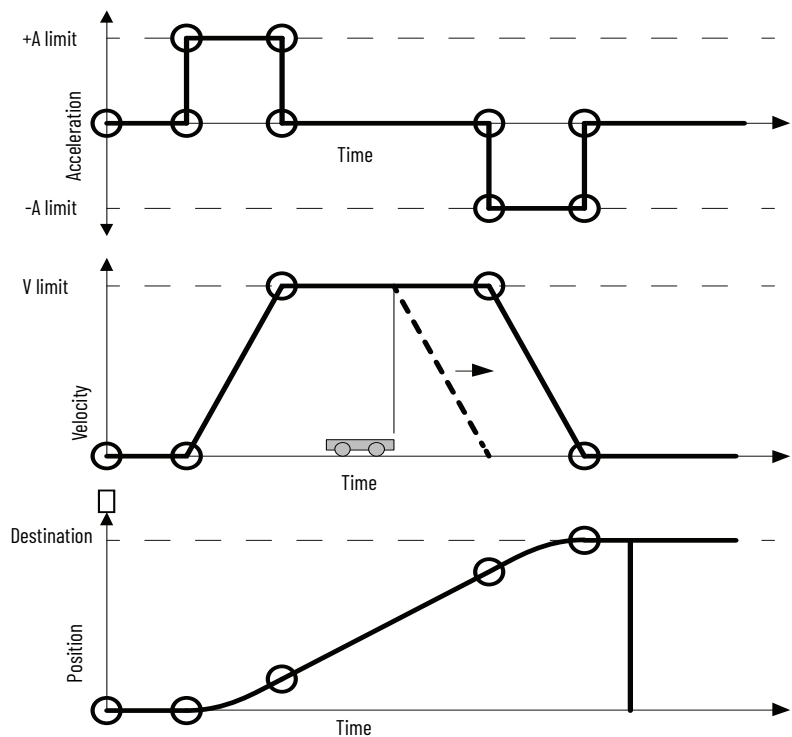

## Thrust Limitations

When a vehicle is commanded with a higher acceleration rate than the motor can provide, the vehicle falls behind its ideal move profile while accelerating. [Figure 63](#) shows both the ideal move profile (solid line) and the degraded move profile (dashed line).

In addition, and more critically, the vehicle is not able to decelerate at the specified rate and overshoots its destination as shown by the dashed line in [Figure 63](#). This behavior can result in vehicles colliding with other vehicles or switch components, or loss of control of a vehicle as it exits the area where it has permission to move. Thus, it is important to avoid commanding a move with an acceleration that is higher than the deceleration capability of the system.

The precise deceleration capability depends on vehicle mass (including payload), center of gravity location, speed, and track geometry. Furthermore, the thrust capability of the motors are reduced in proximity to the gaps between motors.

Figure 63 - Vehicle Movement Profile Showing Thrust Limitations

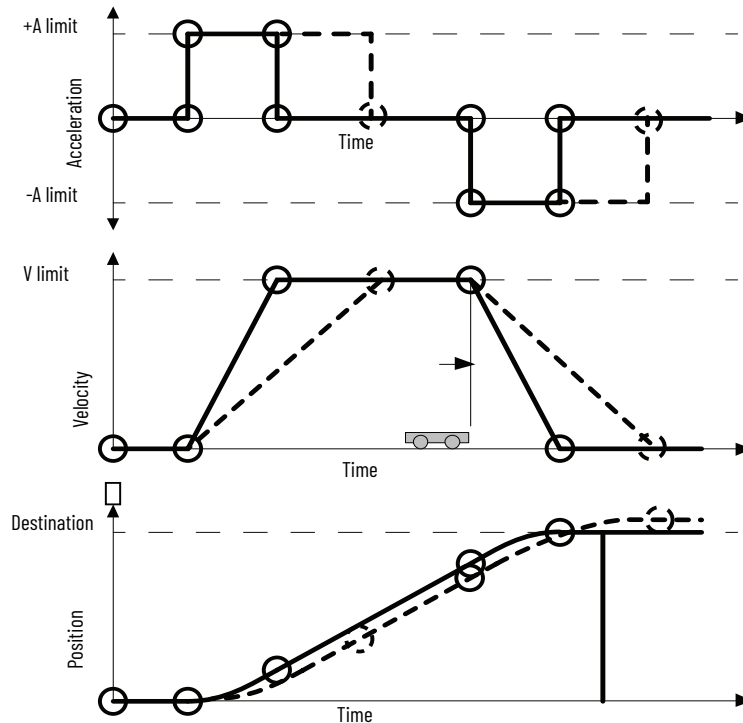

## Automatic Vehicle Queue

Typically, vehicles queue up while in route to a particular destination when another vehicle obstructs the route. Obstructions are normal occurrences, jams are not. While in queue, the vehicles can be as close together as permitted by the system. The amount of space in between the carriers that are mounted on the vehicles depends on the defined length of the vehicle. All vehicles in the queue report being obstructed.

An obstruction indicates that something that the system knows about is keeping the vehicle from completing its current motion order. This obstruction could be another vehicle, a node not ready for a vehicle, or a path that is suspended or has not completed startup. Once the obstruction clears the obstructed vehicle is free to complete its order. Obstructions can include another vehicle or an unavailable node or path.

A hindered signal indicates that there is no known obstruction keeping the vehicle from moving, but the vehicle is not moving towards its destination. This lack of progress is typically due to an unknown obstruction (something having fallen onto the track) or friction within the system that cannot be overcome. Once the jam has been cleared, typically by outside intervention, the vehicle is free to complete its order and any vehicles it has obstructed are free to complete their orders. Other causes of a vehicle being unable to move that are considered a hindered signal are:

- A vehicle is commanded to move with a velocity of zero.
- A vehicle is commanded to move with an effective PID set equal to zero.



## Vehicle Length Through Curves and Switches

The width of the vehicles is not defined in the Node Controller Configuration File. To make sure that multiple vehicles can move on curved sections of the transport system without colliding, the vehicle length must be defined longer than it actually is to account for the width of the vehicle in a curve. The value of the defined length must be calculated using basic trigonometry, see the MagneMotion System Configurator User Manual, publication [MMI-UM046](#).

## Locating Vehicles During Startup

The node controller scans for the magnet array on the vehicles starting from the upstream end of a path and scanning towards the downstream end of the path. When the node controller detects a magnet array (vehicle), it attempts to locate it. For the QS 150 system, so long as the node controller can determine the 'edge' of the vehicle, there is no uncertainty, and the node controller can locate the vehicle without moving (zero move startup). If the node controller cannot determine the 'edge' of the vehicle (because vehicles are positioned such that there is no space between magnet arrays) then the node controller will resort to the previous 'move to locate'. In either case, once the vehicle is located, the node controller will assign the vehicle a unique vehicle ID.

In the move to locate scenario, if another vehicle occupies the adjacent motor block (or there are no more motor blocks downstream), it looks to the next detected vehicle and tries to move it. The node controller continues scanning for vehicles until it locates a new one, or it tries to move an already located vehicle to make room to locate a new vehicle, if there is additional room to move the already located vehicle that is in the way. If the node controller scans to the end of the path, and it was unable to move any detected new vehicles into a downstream motor block or it is unable to move existing vehicles for room, it will attempt to request room from the downstream path if it is in 'startup' mode or it switches directions and begins scanning in the upstream direction from the downstream end of the path. The node controller assigns a vehicle ID to the next vehicle it can move into an adjacent upstream motor block to determine its position.

Once a path successfully locates all its vehicles, the path transitions to a 'ready to help' state in which neighboring paths can request a distance to locate vehicles that are unable to be located within the path (perhaps due to high density of vehicles in a path). Once all vehicles are located, all paths will transition to the Operational state.

If a path is not able to locate its vehicles either by locating within a path or by requesting help from neighboring paths, it will fail startup.



There must be at least one motor block free per path for startup to succeed.

## Electrical System

The QS 150 motors are designed to operate at a nominal 72V DC. The inverters that power the individual blocks within the motor are enabled when the internal propulsion bus for the motor rises above 43V DC, which allows normal motor operation and are shut down if the voltage falls below 41V DC. The inverters in the motor are also shut down when the internal propulsion bus reaches 83V DC to help protect internal circuitry and are enabled when the voltage falls below 82V DC. The logic circuits in the motor are designed to operate at a nominal 48V DC, but start to function once the logic bus rises above 40V DC, which allows reporting of all motor warnings and faults.

Voltage drops in the power distribution system when the motors consume power while moving vehicles and voltage increases during regeneration events lead to fluctuations in the voltage seen at the motor power terminals.

Under normal operating conditions, these fluctuations are minimal and can be ignored. The power supplies and wiring for the system must be designed to minimize these fluctuations, see [Electrical Wiring on page 27](#).

## Power Regenerated by a Vehicle

When a vehicle slows to a stop, the mechanical energy of the vehicle is converted to electrical energy, which is applied to the internal propulsion bus of the motor. This energy must then be dissipated to avoid raising the voltage of the bus beyond the acceptable limit of 80V DC.

Power is provided to the motor to slow down the vehicle actively so the net effective regeneration power is lower than the power required to accelerate the vehicle. The reduction is based on a number of factors, but a conservative estimate is that the net effective regeneration power is about 75% of the acceleration power. As the vehicle slows down under constant deceleration, the regeneration power drops linearly with speed.

## Power Management Within the QS 150 Motor

To supplement any external power management schemes that are applied to a QuickStick 150 transport system, several means of internally consuming regenerated power within a QS 150 motor are incorporated to help protect the motor and help minimize voltage increases. These include both [Block Level Power Management](#), where excess power is dissipated through unused motor blocks, where excess power is dissipated through an internal resistive load.

## Soft Start

If the PTC used to limit inrush current heats up and goes into a high-resistance state, it does not allow the propulsion bus to power up. To keep from overheating the internal soft start resistor, the time from when propulsion power is turned on and turned off must be a minimum of 30 seconds and a minimum of 10 seconds between turn off and turn on (power cycle) as shown in [Figure 64](#).

Figure 64 - Power Cycle Timing

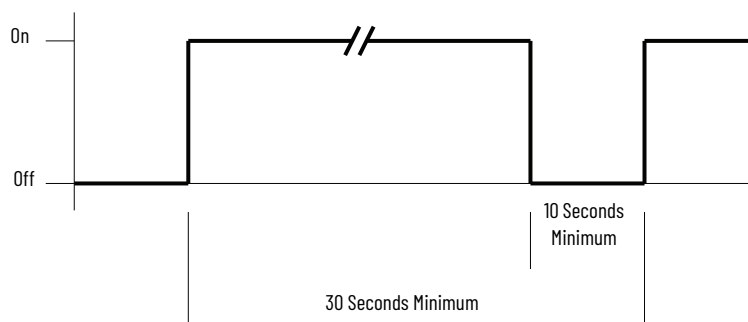

To make sure that the soft start circuit resets for the next turn on:

- Wait a minimum of 30 seconds from turn on to turn on.
- Wait a minimum of 10 seconds from turn off to turn on.
- Wait for the Soft Start Not Complete bit in the motor fault data to be clear before turning the propulsion power back on. See either the MagneMotion Host Controller TCP/IP Communication Protocol User Manual, publication [MMI-UM003](#) or the MagneMotion Host Controller EtherNet/IP Communication Protocol User Manual, publication [MMI-UM004](#).

## Block Level Power Management

When the internal propulsion bus reaches 80V DC, current begins to ramp in the coils of blocks that are available to allow the motor to absorb and dissipate unused power due to regeneration within itself or coming from other motors that are connected to a commonly shared 72V DC power supply effectively. A coil block is defined as available and is used to dissipate power within a motor if its neighboring blocks (upstream and downstream) do not have any part of a magnet array over them. A neighboring block can be within another motor as would be the case for the first and last blocks within a given motor.

The current in these available blocks ramps linearly to 4 A over a 2.5V range from 80V DC to 82.5V DC. The coil current remains constant at 4 A for voltages above 82.5V DC and drops to zero for voltages above 83V DC since all inverters are turned off. This behavior is shown in [Figure 65](#).

**Figure 65 - Individual Block Current vs. Internal Propulsion Bus Voltage**

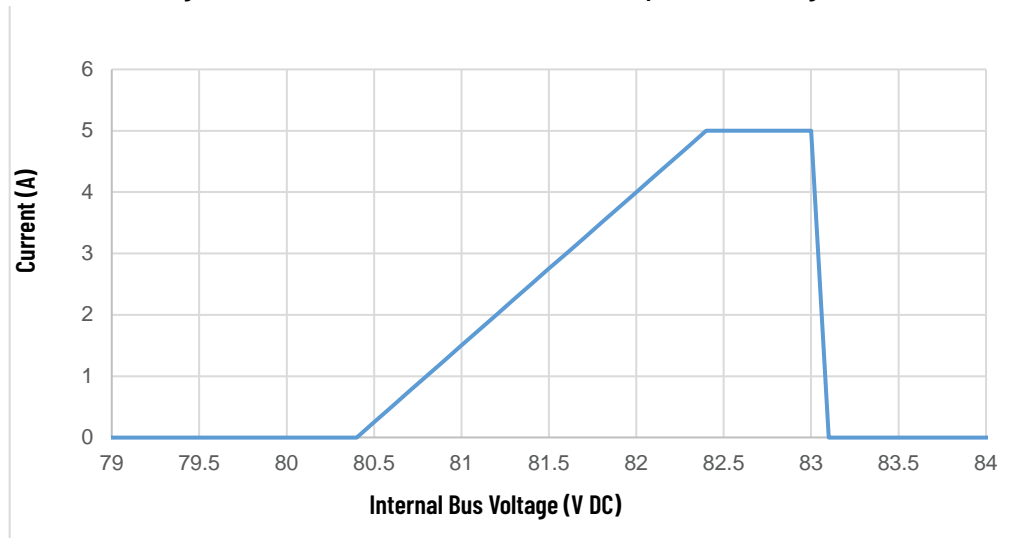

With a nominal block coil resistance of 1.9 Ohms, the dissipated power is 30.4 W per block when the 4 A current level is reached and remains at this level up to 83V DC. The dissipated power vs. the internal propulsion bus voltage is shown in [Figure 66](#).

**Figure 66 - Power Dissipation Per Block vs. Internal Propulsion Bus Voltage**

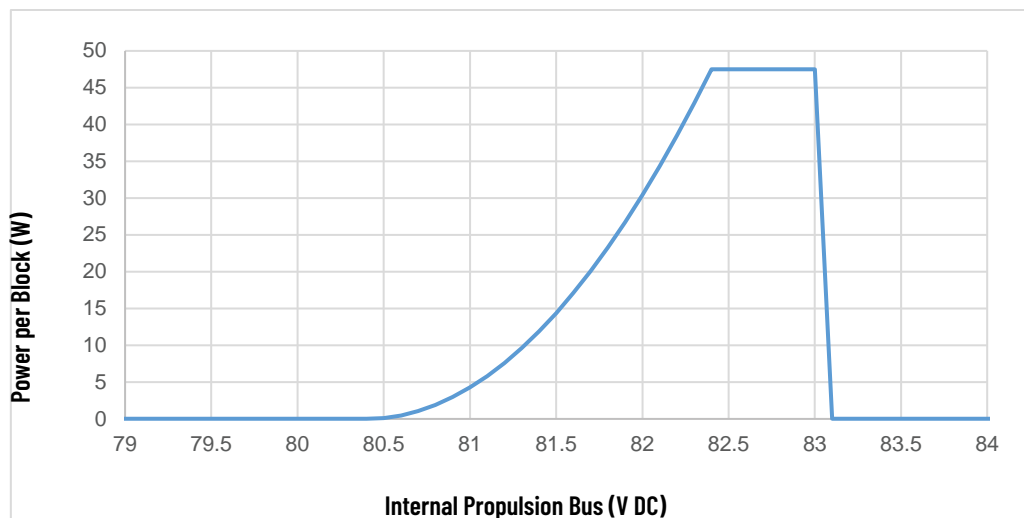

## Node Controllers

The node controller is used to monitor vehicles and control the motors and other components of a QuickStick 150 transport system based on the commands from the host controller. The node controller also provides status information to the host controller. There can be multiple node controllers in a transport system, each responsible for a subset of the transport system. Each node controller is connected to the local area network (LAN) for the transport system. Providing all communications to the node controllers through a LAN allows the node controllers to be located near the motors they are controlling, which minimizes the length of all cabling.

Each node controller is responsible for coordinating vehicle movement through the nodes that are assigned to it and along the paths that are connected to those nodes. The node controllers are also used to program the motors on the paths that are connected to the nodes assigned to it.

One node controller in the transport system also functions as the high-level controller (HLC). The HLC provides one point of contact for all communications with the host controller through either TCP/IP or EtherNet/IP. The HLC distributes any commands or requests that are received to the appropriate node controller through the LAN using TCP/IP and passes any messages from the node controllers to the host controller. The HLC also assigns vehicle IDs and tracks vehicle movement from node controller to node controller to make sure vehicle IDs are maintained.



All TCP/IP communications is unicast. Additionally, do not connect the node controllers to a network with large amounts of broadcast traffic as this extra traffic could impact node controller communication.

### *Node Controller Communications*

All node controllers constantly communicate with the node controller configured as the HLC through a LAN. Additionally, the node controller designated as the HLC communicates with the host controller through the same network.

All node controllers have the same IP address when they leave the factory. Individual node controllers with the same IP address cannot be distinguished on a network and must not be connected to the network until their IP address is set to a unique address that matches the addressing structure of the network for the transport system, see the MagneMotion Node Controller Interface User Manual, publication [MMI-UM001](#).

See the MagneMotion Node Controller Hardware User Manual, publication [MMI-UM013](#) for mechanical dimensions, detailed connector identification and pinouts, and procedures for mounting and connecting the node controllers to the transport system.

## Controls and Indicators

The control application on the host controller must provide any needed controls or indicators that are related to transport system operation. Additional controls and indicators can be configured as described in this section. The controls and indicators of the QuickStick 150 components are identified in the [Motor Status Indicators on page 66](#).

### **Track Display**

The NCHost TCP/IP Interface Utility can be used to display the Graphics Window, which is shown in [Figure 67](#). The Graphics Window shows the transport system layout and all vehicles in the transport system for real-time monitoring of transport system operation.

This display can only be used if there is a Track file for the specific configuration (created by Rockwell Automation). See the MagneMotion NCHost TCP/IP Interface Utility User Manual, publication [MMI-UM010](#) for instructions on how to use the Graphics Window.

Figure 67 - The Graphics Window

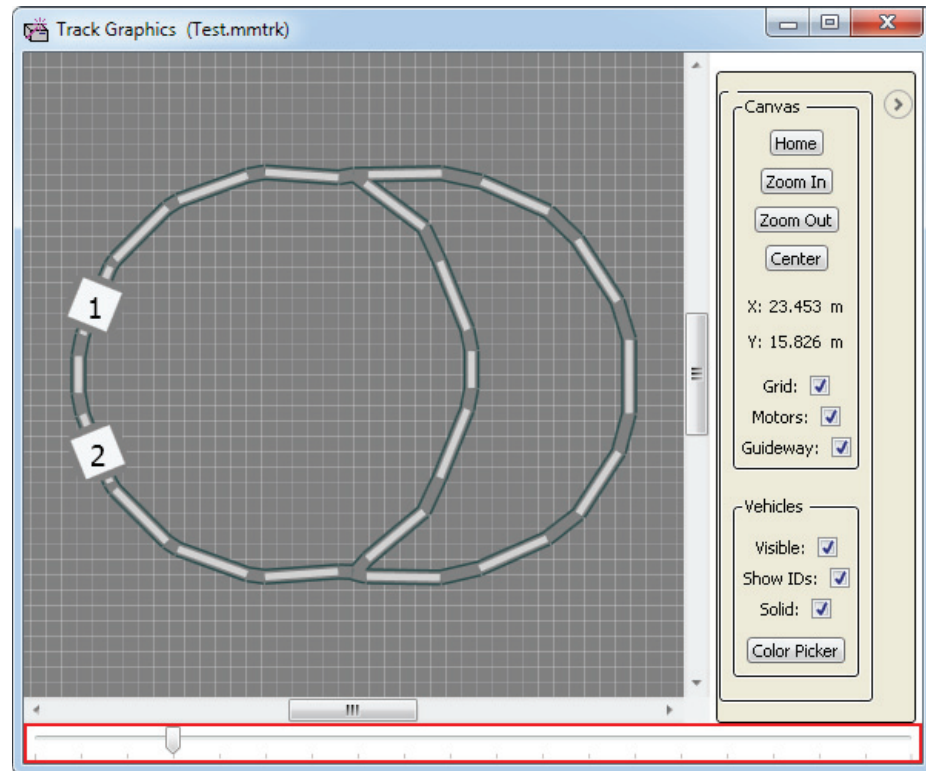

## FastStop

The host controller can send a FastStop command to the node controller, on a per-path basis. This command suspends all motion on the specified paths. Vehicles immediately decelerate with maximum thrust opposing their motion. Previously commanded motion does not resume until a Resume Motion command is received. The control loop is still enabled while motion is suspended holding all vehicles in place. See the MagneMotion Host Controller TCP/IP Communication Protocol User Manual, publication [MMI-UM003](#) and the MagneMotion Host Controller EtherNet/IP Communication Protocol User Manual, publication [MMI-UM004](#) for details on the use of the FastStop command.

## Transport System Operation

### Power-up



The QuickStick 150 transport system is started by applying power as previously specified, see [Check-out and Power-up on page 63](#). Once the system completes startup, the QS 150 components are ready to operate. If the host controller is in control of the QS 150 transport system, the system accepts commands from the host controller through the network connection.



**ATTENTION:** All switch settings, communication connections, and power connections must be made before power is applied.



## Normal Running

During normal operation, the host controller controls the QuickStick 150 transport system. The user must determine the exact usage of the QS 150 transport system. See the MagneMotion Host Controller TCP/IP Communication Protocol User Manual, publication [MMI-UM003](#) for details of each command to use TCP/IP communication. See the MagneMotion Host Controller EtherNet/IP Communication Protocol User Manual, publication [MMI-UM004](#) for details of each user-defined tag and the PLC interface to use EtherNet/IP communication.

	 <b>WARNING</b>
	<p style="text-align: center;"><b>Crush Hazard</b></p> <p>Moving mechanisms (vehicles) have no obstruction sensors. Do not operate the QuickStick 150 transport system without barriers in place or personal injury could result in the squeezing or compression of fingers, hands, or other body parts between moving mechanisms.</p>

## Safe Shut-down

The following shut-down procedure is used to remove power from the QuickStick 150 transport system in an orderly manner and place the components in known safe conditions. This procedure is used to prepare the components for removal, replacement, or maintenance.

	 <b>CAUTION</b>
	<p style="text-align: center;"><b>Electrical Hazard</b></p> <p>The shut-down procedure is used in the normal shut-down of the QuickStick 150 transport system. This procedure removes the power source and all other facilities to the components and provides guidelines for lockout/tag-out. This procedure is NOT the same as an EMO circuit or other safety interlock.</p>

The QuickStick 150 motor require no special shut-down procedures, however the QS transport system should follow these steps to help avoid damage to external components. When shutting down the host controller, the QS 150 components must be shut down first.

1. All material transfers must be completed (move all material to the appropriate locations).
2. Command all vehicles to known positions.
3. Issue a Suspend Motion command for all paths.  
All vehicles come to a controlled stop.
4. Once all motion has stopped, issue a Reset command for all paths.  
The HLC clears all vehicle records.
5. Turn off all power to the motors.
6. Turn off power to the node controllers.
7. Turn off power to the host controller.
8. Turn off the main power disconnect for the QS 150 transport system.



This procedure only shuts down facilities to the QuickStick 150 motors, their subsystems, and the host controller. Any user-supplied equipment remains powered up.

## Maintenance

This chapter provides maintenance schedules and procedures for the QuickStick® 150 components. Only trained, qualified personnel should perform maintenance or troubleshooting on the QS 150 transport system. Rockwell Automation provides training in the troubleshooting and repair of the QS 150 transport system.



**SHOCK HAZARD:** Do not attempt the procedures in this document unless you are qualified to do so and are familiar with solid-state control equipment and the safety procedures in the Standard for Electrical Safety in the Workplace, publication NFPA 70E.

## Preventive Maintenance

The motors, node controllers, and power supplies in the QS 150 transport system are self-contained components that are designed for use in a clean, inert environment, and require no maintenance other than that described here. Any deviation from this basic environment can affect the maintenance requirements, contact [Rockwell Automation Support](#) for additional information. See [Troubleshooting on page 95](#) if any problems are detected.

**Table 18 - QuickStick 150 Transport System Preventive Maintenance Schedule**

Component	Maintenance Action	Frequency <sup>(1)</sup>	Page #
QS 150 Transport System	<a href="#">Cleaning</a>	3 months or as required	87
	<a href="#">Spray Cleaning</a>	3 months or as required	88
	<a href="#">Wear Surface Maintenance</a>	3 months or as required	88
	<a href="#">Cable Connection Inspection</a>	3 months or as required	89
	<a href="#">Hardware Inspection</a>	3 months or as required	89
	<a href="#">Cleaning Magnet Arrays</a>	3 months or as required	89

(1) The specified frequency is based on a certified clean, inert environment. Adjust the facility preventative maintenance schedule to account for any deviations from this environment.

## Cleaning

General cleaning of the QuickStick 150 transport system consists of cleaning the transport system surfaces as described.

### Required Tools and Equipment

- Disposable gloves
- Microfiber cleaning cloth
- Deionized water
- Isopropyl alcohol (optional)

### Procedure

1. Stop all motion on the sections of the QS 150 transport system to be cleaned.
2. Remove system power and allow the system time to de-energize.
3. While wearing gloves, clean all exposed transport system surfaces and cables with a clean microfiber cloth slightly dampened with deionized water or isopropyl alcohol. Wipe in the direction of the grain on all surfaces that have a grain.
4. Make sure that all components are dry.
5. Resume motion on the sections of the QS 150 transport system that were stopped.

### Spray Cleaning

Spray cleaning the QS 150 motors or the material being moved on the motors consists of providing a constant water spray as defined by IP66/IP67 as described below. To ensure IP66/IP67 ratings, tighten cable collars to 11 lb•in (1.24 N•m).



Only the motors, vehicles, and magnet arrays are IP66 washdown compatible. Ensure all components that are not IP66 washdown compatible (power supplies, Node Controllers, etc.) are not exposed to water spray.



Only the motors, vehicles, and magnet arrays are IP67 submersion compatible, for 30 minutes in a 1.0 meter of water. Ensure all components that are not IP67 compatible (power supplies, node controllers, etc.) are not exposed to water submersion.

1. Ensure all components that are not IP66 washdown compatible (power supplies, Node Controllers, etc.) are appropriately covered.
2. If only the motors are being cleaned, stop all motion on the sections to be cleaned. If material in transit is being cleaned, motion does not need to be stopped and the speed should be adjusted to ensure proper cleaning of the material.
3. Initiate the IP66 washdown of compatible components (motors, switches) or material in transport.
  - Maximum water volume: 12.5 L (0.26 gpm)
  - Maximum pressure: 100 kpa = 14.5 psi at a distance of 3 m (9.8 ft)
4. If only the motors are being cleaned, ensure all components are dry and return the transport system to normal operation.

### Wear Surface Maintenance

The vehicles that are used on the QS 150 transport system may need to be rotated to make sure that there is even wear on the wheels. This is especially true for vehicles that are used in a transport system where all motion is in one direction, for bogies in a tandem vehicle configuration, or for vehicles that have a cantilevered load.



Rotating vehicles is only done for vehicles where the magnet array is centered on the vehicle. For vehicles where the magnet array is not centered, the design of the vehicle will determine if it is possible to rotate the vehicle.

1. Stop all motion on the QS 150 transport system.
2. Remove system power and allow the system time to de-energize.
3. Remove the vehicles from the QS 150 transport system.
4. Rotate the vehicles 180°.



5. Replace the vehicles on the QS 150 transport system.

### Cable Connection Inspection

1. Stop all motion on the sections of the QS 150 transport system to be inspected.
2. Remove system power and allow the system time to de-energize.
3. Verify that all cable connectors are fully seated and screws/locks are secured to achieve good continuity. To ensure IP66/IP67 ratings, tighten cable collars to 11 lb•in (1.24 N•m).
4. Inspect all cables for restricting bend radii, excessive tension, or physical damage.
5. Return the QS 150 transport system to normal operation.

### Hardware Inspection

1. Stop all motion on the sections of the QS 150 transport system to be inspected.
2. Turn off all QS 150 transport system components with accessible power controls.
3. Remove system power and allow the system time to de-energize.
4. Make sure that all motor stand hardware is secure.
5. Make sure that all guideway mounting hardware is secure.
6. Make sure that all motor mounting hardware is secure.
7. Make sure that all vehicle grounding materials (for example, static brushes) are secure and functioning properly.
8. Make sure that all vehicle hardware, especially the hardware securing the magnet array, is secure.
9. Make sure that the vehicle gap (distance between the magnet array on the vehicle and the motor) is within tolerance for all vehicles on all motors.
10. Return the QS 150 transport system to normal operation.

### Cleaning Magnet Arrays

The magnet arrays attract ferrous particles from the air and surrounding surfaces. These particles accumulate and appear as small tin-whiskers on the surface of the array.

- Use adhesive tape to capture the ferrous particles on the magnet arrays.
- To combat accumulated debris, keep magnet arrays not being used in their original container.
- Proper precautions must be taken when magnet arrays with stainless steel covers are used in wash down applications or in environments where water or fluids are contacting the array. The mounting must secure the array with a suitable form of gasket to help prevent water ingress into the array through either its back surface or the seam where the cover meets the back iron of the array. The top surface and sides of the cover are water-resistant.

## Motor Replacement

If a component of the QuickStick 150 transport system malfunctions, see [Troubleshooting on page 95](#) in this manual for diagnostic procedures. If these procedures are not adequate to determine the source of the problem, see [Rockwell Automation Support](#). Once the failed unit has been identified, a

replacement unit can be ordered and installed as directed in [QuickStick 150 Motor and Magnet Array Installation on page 49](#).



The components of the QuickStick 150 transport system are designed for easy replacement. Motors, controllers, and other modules do not contain any user serviceable parts.



**ATTENTION:** Only a qualified service representative can service the components of the QuickStick 150 transport system. Any attempt to open the transport system modules by anyone other than a qualified Rockwell Automation service representative voids the warranty.

## Replacing Motors

The QuickStick 150 motors can typically be replaced easily depending upon the location and mounting method for the motor.



### Required Tools and Equipment

- Metric hex wrenches
- English hex wrenches
- Open-end wrench, adjustable
- Fork truck or appropriate lift as required

	<b>CAUTION</b>
	<p><b>Electrical Hazard</b></p> <p>Before beginning this procedure, the QuickStick 150 transport system must be shut down following the procedure that is provided in <a href="#">Safe Shut-down on page 86</a>.</p>

### Remove the Existing Motor

1. Complete all material transfers (move all material to the appropriate locations) on the section of the QS 150 transport system where the motor is being replaced.
2. Command all vehicles to positions off the path where the motor is being replaced.
3. Issue a Suspend Motion command for the path where the motor is being replaced.  
All vehicles come to a controlled stop. Make sure there is not a vehicle over the motor that will be replaced.
4. Once all motion has stopped, issue a Reset command for the path where the motor is being replaced.  
The HLC clears all vehicle records.
5. Turn off and disconnect all power and communication connections as detailed in [Safe Shut-down on page 86](#).
6. Allow the transport system time to discharge.
7. Label the power and communication connections to the motor.
8. Disconnect all connections.
9. Remove the M8 bolts that secure the motor to the motor mounts.
10. Remove the motor from the transport system.

 	<div style="background-color: yellow; text-align: center; padding: 5px;">  <b>CAUTION</b> </div> <p style="text-align: center;"><b>Heavy Lift Hazard</b></p> <p>The QuickStick 150 motors can weigh as much as 15.42 kg (34 lb). Failure to take the proper precautions before moving them could result in personal injury.</p> <p>Use proper techniques for lifting and safety toe shoes when moving any QuickStick 150 components.</p>
--	--

11. Store the motor in a secure location.
12. See [Shipping on page 92](#) to return the motor to Rockwell Automation.

#### Install the New Motor

1. See [Mounting the Motors on page 52](#) for detailed installation instructions.
2. Reconnect the power and communication connections to the motor (refer to the labels previously placed on the cables).
3. Update MICs file with the new motor MAC address.
4. Restore power to the section of the QS 150 transport system where the motor was replaced.
5. Program the motor controller and driver on the new motor with the current Motor image files, see [Programming Replaced Motors on page 91](#).
6. Resume motion on the section of the QS 150 transport system where the motor was replaced.

## Programming Replaced Motors

When a new QuickStick 150 motor is installed, either as part of a new system installation or as a replacement for an existing motor it must be programmed with the appropriate Motor ERF Image file (*motor\_image.erf*).



QuickStick 150 motors are shipped from the factory with just a basic motor software image installed. They must be programmed with the software that is supplied with the motors before use.

#### Required Tools and Equipment

- Computer
- Motor ERF Image files

#### Procedure

1. Upload the Motor ERF Image files (*motor\_image.erf*) to each node controller by using the node controller web interface and program the motor. See the MagneMotion Node Controller Interface User Manual, publication [MMI-UM001](#) for details.



Restart the node controller for the changes to take effect.



2. Reset the paths where the motors were programmed (for example, use the NCHost TCP/IP Interface Utility, see the MagneMotion NCHost TCP/IP Interface Utility User Manual, publication [MMI-UM010](#) for details.



## Ordering Parts

If new or replacement parts are needed, contact Rockwell Automation Sales.

## Shipping

If a QuickStick 150 component must be shipped, either for return to Rockwell Automation or to another location, it must be packaged properly to make sure that it arrives undamaged. The following procedure provides the correct method for handling and packaging QS 150 components for shipment.

	 <b>WARNING</b>
	<p style="text-align: center;"><b>Strong Magnets</b></p> <p>To avoid severe injury, people with pacemakers and other medical electronic implants must stay away from the magnet arrays. To avoid severe injury from strong magnetic attractive forces:</p> <ul style="list-style-type: none"> <li>• Handle only one vehicle or magnet array at a time.</li> <li>• Do not place any body parts, such as fingers, between a magnet array and any QuickStick 150 motors, ferrous material, or another magnet array.</li> <li>• Magnet arrays or vehicles not being used must be secured individually in isolated packaging.</li> <li>• Magnet arrays being shipped, for return or to another facility, must be shipped per U.S. Department of Transportation and The International Air Transport Association (IATA) Dangerous Goods Regulations.</li> </ul> <p>To avoid damage to watches, instruments, electronics, and magnetic media, keep metal tools, metal objects, magnetic media (for example, memory disks/chips, credit cards, and tapes) and electronics away from the magnet arrays.</p>



	 <b>CAUTION</b>
	<p style="text-align: center;"><b>Heavy Lift Hazard</b></p> <p>The QuickStick 150 motors can weigh as much as 15.42 kg (34 lb). Failure to take the proper precautions before moving them could result in personal injury. Use proper techniques for lifting and safety toe shoes when moving any QuickStick 150 components.</p>

1. Make sure that the component has been properly decontaminated following the decontamination procedures for the facility. Follow all facility, local, and national procedures for the disposal of any hazardous materials.
2. When shipping individual components, remove all components to be shipped, see [QuickStick 150 Motor and Magnet Array Installation on page 49](#) and reverse the sequence to remove the components. Then see [Shipping Components on page 93](#).

3. Each component must be wrapped, bagged, and packed following standard packing procedures.
4. Use the container that the component was originally shipped in and set the component into the container and secure using the supplied packing material.
5. Close the shipping container and secure.

#### Shipping Components

1. Make sure that the container is properly labeled (This End Up, Caution – Heavy, and so on) and all shipping documents are attached to the outside of the container.

	 <b>CAUTION</b>
	<p style="text-align: center;"><b>Magnetic Field Hazard</b></p> <p>When shipping magnet arrays, make sure that the shipping container properly isolates the magnet arrays or identifies the Magnetic Field Hazard.</p> <p>Magnet arrays being shipped, for return or to another facility, must be shipped per U.S. Department of Transportation and The International Air Transport Association (IATA) Dangerous Goods Regulations.</p> <ul style="list-style-type: none"> <li>• Storage – Store magnet arrays in appropriate storage or shipping containers (shielded with steel or isolated). Never leave magnet arrays unattended outside the storage containers. If unshielded magnet arrays must be left unattended, the area must be marked with a Magnetic Hazard Sign in accordance with the applicable facility, local, and national safety codes for the installation site.</li> <li>• Handling – Appropriate handling is required. Handle only one magnet array at a time. If an array is attracted to another object, DO NOT attempt to stop it. Wearing gloves and safety glasses when handling the magnet arrays is recommended. Inspect the area before handling the magnet arrays and make sure it is free of other magnet arrays or ferromagnetic materials.</li> </ul>

2. When shipping to Rockwell Automation, make sure that the RMA number is clearly visible on the outside of the container.

**Notes:**

## Troubleshooting

This section describes the common difficulties that are encountered with the QuickStick 150 transport system and software components.

For assistance, see [Rockwell Automation Support](#).

### Initial Troubleshooting

This section covers the initial determination of the problem area within the QuickStick 150 transport system and provides direction to the second step of the troubleshooting process. If a specific problem is suspected, see that problem in [Table 19](#). If the problem has not been identified, review each of the symptoms that are identified in [Table 19](#) to help determine the problem area.

**Table 19 - Initial Troubleshooting**

Symptom	Possible Problem Area
Power lights do not turn on.	See <a href="#">Power-Related Troubleshooting on page 95</a>
Motors report power-related faults.	
Vehicles do not seem to move as fast as when the QS 150 transport system was initially installed.	See <a href="#">Power-Related Troubleshooting on page 95</a> See <a href="#">Table on page 100</a>
Node controller logs do not indicate correct time.	See <a href="#">Table on page 99</a>
QS 150 transport system does not respond to the host controller.	See <a href="#">Communication Troubleshooting on page 99</a> See <a href="#">Motion Control Troubleshooting on page 100</a>
Vehicles producing excessive noise.	See <a href="#">Motion Control Troubleshooting on page 100</a>
Fault Lights are on.	See <a href="#">Fault Light Troubleshooting on page 101</a>

### Power-Related Troubleshooting

This section covers the determination of power-related problems within the QuickStick 150 transport system.

**Table 20 - Power-Related Troubleshooting**

Symptom	Problem Description	Corrective Action
Lights on power supplies do not turn on	No power or incorrect power being supplied.	Verify that the cable from the facility power is fully seated and secured. Verify that the facility power to the QS 150 transport system is the correct power rating.
	Power supply main fuses are blown.	Replace fuses and determine the cause to minimize the chance of recurrence.
Motors do not move the vehicles at full speed	Power supply is not providing full power.	Verify that the power supply air filter is not dirty. Clean or replace if necessary. Verify that power supply vents are not obstructed.
	Transport system motion control issues.	Review <a href="#">Motion Control Troubleshooting on page 100</a> .

**Table 20 - Power-Related Troubleshooting (Continued)**

Symptom	Problem Description	Corrective Action
One or more motors do not operate	Power or communication to the affected motors is lost or intermittent.	Verify that the cables to the affected motor are fully seated and secured.
	Power supply is not providing full power.	Verify that the power supply for the affected motor is operating properly.
		Verify the output voltage from the power supply. Verify that the power supply fuses are not blown. Replace if necessary and determine the cause to help prevent recurrence.
Motor Internal Fuse	Fuse Fault	The internal propulsion fuse has opened. This fuse is not replaceable. Unit must be sent back to factory to be repaired
Motor reports 'Not in operational mode'	This is the initial state at power up. The motors will automatically transition to operational mode. This fault is informational only.	Wait 100 ms after reset or power on before sending any commands to the motor.
After power cycling the 48V DC propulsion power line multiple times, the motor does not clear the under-voltage fault	The PTC used to limit inrush current eventually heats up enough that it goes to a high-resistance state. This state does not allow the motor controller to power up enough to clear the under-voltage fault.	Turn off the propulsion power supply for a few minutes to allow the PTC to cool down sufficiently to allow proper resumption of operation upon reapplication of the power source. Make sure that there is a minimum of 30 seconds between turn on cycles and 10 seconds between turn off and turn on (power cycle). Additionally, monitor the Soft Start bit to make sure it is off before turning the propulsion power back on.
The motor reports an under-voltage fault	Power being supplied to the motor is not sufficient. See <a href="#">Under-voltage Fault on page 97</a> .	Verify the voltage output from the power supply.
		Verify the voltage at the motor.
		Verify that all power wiring is sufficient to carry all loads and deliver the proper power to the motors.
		Reduce power cable resistance between motors that share a common propulsion supply. The fault clears once the power bus rises above 43V DC.
The motor reports a Soft Start not complete fault	The internal power bus for the motor is below 41V DC.	The fault clears once the power bus rises above 43V DC.
The motor reports an over-voltage fault	Power being supplied to the motor is above 59V DC. See <a href="#">Over-voltage Fault on page 98</a> .	The fault clears once the power bus drops below 83V DC.
		Verify the voltage output from the power supply.
		Verify the voltage at the motor.
		Reduce power cable resistance between motors that share a common propulsion power supply.
		Reduce maximum speed and/or maximum acceleration to reduce the amount of regenerated power that flows back into the system.
		Increase the spacing between vehicles on motors that share a common propulsion power supply. Connect more motors to a common propulsion power supply to increase the number of blocks available to absorb regenerated power.



## Power Related Warnings and Faults

Fluctuations in the voltage that is seen at the motor power terminals are due to voltage drops when the QS 150 motors consume power while moving vehicles and voltage increases during regeneration events.

These fluctuations can lead to the motor issuing warnings and faults and can cause motor shutdown as shown in [Table 21](#). See also [Table 17](#).

See either the MagneMotion Host Controller TCP/IP Communication Protocol User Manual, publication [MMI-UM003](#) or the MagneMotion Host Controller EtherNet/IP Communication Protocol User Manual, publication [MMI-UM004](#) for additional information.

**Table 21 - Propulsion Voltage Range**

Voltage Level		Event	Status
48V	72V		
41	41	Soft Start not complete fault triggered	Voltage Too Low Motor operation suspend
41	41	Under-voltage fault triggered	
43	43	Minimum recommended operating voltage	Operating Range
51.5	80	Blocks begin dissipating power	
53.5	82.5	Blocks reach maximum power dissipation	
56.5	82.5	Maximum recommended operation voltage	
58	83	Over-voltage fault triggered, inverters disabled	Voltage Too High Motor operation suspended

### *Soft Start Not Complete Fault*

Upon initial power up, when the internal propulsion bus in the motor is below 43V DC, the motor reports a soft start not complete fault to the HLC. The HLC reports this fault to the host controller as a soft start not complete fault if the motor does not allow vehicle motion to occur. Once 43V DC is reached, the motor supports vehicle motion and the soft start fault message self-clears.

If the internal propulsion bus voltage drops below 41V DC during operation, the motor reports a soft start not complete fault through the HLC to the host controller. When this fault is reported, all inverters within the motor are disabled, and any vehicles in motion over the motor are no longer under active control and as such their motion is undefined. Normal operation resumes once the internal propulsion bus rises back up to 43V DC.

### *Under-voltage Fault*

Upon initial power-up, when the internal propulsion bus in the motor is below 41V DC, the motor reports an under-voltage fault to the HLC. Once this fault clears, it only reappears if the internal propulsion bus voltage drops below 41V DC. The HLC reports this fault to the host controller as an under-voltage fault. This fault self-clears when the internal propulsion bus voltage rises above 43V DC.

If the internal propulsion bus voltage drops below 41V DC during operation, the motor reports an under-voltage fault through the HLC to the host controller. When this fault is reported, all inverters within the motor are disabled, and any vehicles in motion over the motor are no longer be under active control and as such their motion is undefined. Normal operation resumes once the internal propulsion bus rises back up to 43V DC.

This fault is likely due to excessive propulsion power cable resistance from the power source to the motor or power supply is not

### *Over-voltage Fault*

When the internal propulsion bus in the motor rises above 82V DC, the motor reports an over-voltage fault to the HLC. The HLC reports this fault to the host controller as an over-voltage fault.

When this fault is reported, all inverters within the motor are disabled, and any vehicles in motion over the motor are no longer under active control and as such their motion is undefined. This fault self-clears and normal operation resumes once the internal propulsion bus voltage falls below 57V DC. To avoid issuing an over-voltage fault to the host controller due to spurious noise, the internal propulsion bus that is used to trigger this event is filtered.

Based on the specific system wiring and vehicle activity, it is possible for regenerated power resulting from vehicle decelerations to cause the internal propulsion bus voltage to rise to excessive levels. To help protect against this, protective features guard against operating conditions that could damage the motor. Since the source of such a condition is due to regeneration effects associated with active braking or deceleration of a vehicle (loaded or unloaded), a means (among others) of mitigating such regenerated power is to shut down the inverters in the motor.

### **Power Related Fault Resolution**

The power-related error messages and the associated faults persist until the voltage of the internal propulsion bus in the motor is between 42.5V and 82.5V DC. Once the voltage is within the operating range, the system attempts to resume active control of the vehicle. There are several possible solutions available to mitigate faults of these types.

- Reduce the cable resistance between the power supply and the motors if a voltage drop in these cables leads to under voltage on motors accelerating vehicles.
- Reduce the cable resistance between motors that share a common propulsion power supply if a voltage drop in these cables leads to under voltage on motors accelerating vehicles or excessive voltage on motors undergoing regeneration.
- Reduce the maximum speeds and/or maximum accelerations to reduce the amount of power that is drawn and the regenerated power flowing back into the system.
- Reduce the number of vehicles accelerating on motors that are connected to the same common propulsion power supply.
- Split the power bus into smaller sections and install additional power supplies.
- Increase the spacing between vehicles on motors sharing a common propulsion power supply to increase the number of blocks available to absorb power during regeneration.
- Connect more motors to a common propulsion power supply to increase the number of blocks available to absorb regenerated power.

If all of these resolution paths have been explored and excessive voltage problems still persist, add an active voltage clamp across the propulsion power supply local to the power supply or to the motors that are exhibiting this issue. The clamping voltage should be above 51V DC but kept as low as possible.

## Node Controller Troubleshooting

This section covers the determination of problems within the node controllers.

Table 22 - Node Controller Related Troubleshooting

Symptom	Problem Description	Corrective Action
Node controller logs do not indicate the correct time	The battery for the clock in the node controller has lost its charge.	Manually correct the time each time the node controller is powered up or return the node controller to Rockwell Automation for repair. Use the node controller web interface <b>Set Clock</b> function to set the time, see the MagneMotion Node Controller Interface User Manual, publication <a href="#">MMI-UM001</a> .

## Communication Troubleshooting

This section covers the determination of communication-related problems within the QuickStick 150 transport system.

Table 23 - Communication-Related Troubleshooting

Symptom	Problem Description	Corrective Action
QS 150 motors are powered but there is no response to the host controller	Communication to the affected motors is lost or intermittent.	Verify that all communication cables are fully seated and secure. Check for proper connection and continuity of all connections. Check communication to the host controller. Make sure that logic power is enabled.
	Host controller application issue.	Verify that the host controller is correctly configured. Verify that the host application software is correctly written.
Intermittent Communication with the host controller	Communication is lost or intermittent.	<ul style="list-style-type: none"> <li>Make sure that all network cables are properly seated.</li> <li>Check the network traffic to determine if there is latency in the architecture.</li> <li>Check settings on the network switch which could cause delays in traffic.</li> </ul>
QS 150 motors respond to the host controller but the motors do not operate	Power to the affected motors is lost or intermittent.	Make sure that power cables to all motors are properly seated. Make sure that propulsion power is enabled.
	E-stop or interlock circuit is activated.	Make sure that any E-stops or interlocks that are configured for the paths where the motors are located are in the operate state.

## Motion Control Troubleshooting

This section covers the determination of motion-related problems within the QuickStick 150 transport system.

Table 24 - Motion Control Related Troubleshooting

Symptom	Problem Description	Corrective Action
Material slips while the vehicles are in motion	Vehicle is not designed to carry that specific material.	Make sure that the vehicle design is correct.
	Vehicle is not holding the material securely.	Make sure that all material contact surfaces are clean.
	Motion configuration issue.	Make sure that the vehicle acceleration is correct.
		Make sure that the vehicle speed is correct. Make sure that the PID values are correct.
Vehicles do not move smoothly or movement is noisy	Debris on the guideway.	Make sure that the guideways and motors are clean.
	Misalignment of sections of the guideway.	Make sure that the joints between guideway sections are properly secured and co-planar.
	Power or communication to the affected motors is lost or intermittent.	Make sure that the power and communication cables to all motors are properly seated.
	Motion configuration issue.	Make sure that the PID values are correct.
Vehicles are losing thrust	Excessive noise when the vehicle moves from section to section of the guideway.	Make sure that the motors are properly mounted and the transition from one section of guideway to the next is smooth (sections must be at the same height).
	Misalignment or wear of sections of the guideway.	Make sure that the vehicle gap is consistent at all locations on the guideway. Make sure that the vehicle and/or track wear is within tolerance.
	Thrust is lost when the vehicle moves from motor to motor.	Make sure that the downstream gap does not exceed minimum amount of the magnet array length.

## Fault Light Troubleshooting

This section covers the determination of light stack-related problems within the QuickStick 150 transport system. See also [Motor Status Indicators on page 66](#).

Table 25 - Fault Light Troubleshooting

Component	Component			Problem Description	Corrective Action
	Power	Module	Network		
<b>All</b>	Solid Green	Solid Green	Solid Green	Motor in operational state; no faults.	—
<b>Power</b>	Off	Off	Off	Motor does not have control or propulsion power.	Check wiring and power supplies to ensure motor has correct power.
	Solid Red	Off	Off	Motor has propulsion power but not control power.	Check wiring and control power supply to ensure motor has correct power.
	Flashing Green	Solid Green	Solid Green	Motor has propulsion under-voltage fault.	Check wiring and propulsion power supply to ensure motor has correct power.
	Flashing Red	Solid Green	Solid Green	Motor has propulsion over-voltage fault.	Check propulsion supply to ensure proper voltage.
	Solid Red	Solid Red	Solid Green	Fuse open/Soft Start not complete.	Major fault. The motor module section detected a non-recoverable fault.
<b>Network</b>	Solid Green	Solid Green	Flashing Green	Motor has not been provisioned.	Ensure that the Ethernet connection is connected and that the motor has an entry in the MICS file on the node controller.
	Solid Green	Solid Green	Flashing Red	Motor can not communicate with the node controller.	Ensure that the Ethernet connection is connected and the node controller is powered on.
<b>Module</b>	Solid Green	Red/Green Alternate	Solid Green	The motor section is powering up and/or performing initiation tasks. (Example: Programming, boot loader mode.)	Upgrade the motor firmware using the node controller.
	Solid Green	Flashing Green	Solid Green	Motor is in standby. (Example: Suspended / Fast Stop by the node controller.)	Start up the path associated with this motor.
	Solid Green	Flashing Red	Solid Green	Major recoverable fault. The motor module section detected a recoverable fault. (Example: Over-temperature, over-current)	View node controller log file for more details.
	—	Alternate Red	Alternate Red	Alternating Mod NET flashing red; firmware update in progress. Do not remove control power.	—

**Notes:**

## Numerics

**1585D-M4TBDM-x** 45

**1585D-M4TBJM-x** 45

**1585J-M8TBJM-x** 45

## A

**Additional Resources** 15

**Anti-collision** 78

## B

**Bend Radius Cable** 40, 41

**Block Acquisition** 77

**Block Length** 21

**Block Ownership** 78

**Block Release** 78

### Blocks

acquisition 77

ownership 78

release 78

**Brick-wall Headway** 79

## C

### Cable

bend radius 40, 41

catalog number explanation 36

design 27

ethernet 44

inspection 89

motor power 41

mounting clearance 35

### Catalog Number Explanation

cable 36

magnet array 37

motor 32

**Check-out** 63

**Cleaning** 87

### Communication Cables

identification 19

installation 60

**Computer Requirements** 29

### Connections

cable mounting clearance 35

communication 61

facilities 63

motor power 62

motor to motor 60

RS-422 44, 60

troubleshooting 95

**Control Input Power** 39

### Curve

track configuration 54

vehicle 81

## D

**Demo Script**

create 29

## Design

transport system 47

### Dimensions

0.3 m motor 34

0.5 m motor 34

1.0 m motor 34

cable mounting clearance 35

magnet array 38

motor orientation 63

**Downstream Gap** 53

**Dual Array Vehicle** 56

**Dual Magnet Array**

alignment in curves 68

**Dual-array Vehicle** 70

## E

### Electrical

connect motors 58

facilities connection 63

inverter 81

shut down 86

system 81

troubleshooting 95

wiring 27, 62

wiring block diagram 27

**Equipment Safety** 9

### Ethernet

motor connection 44

transport system layout 26

troubleshooting 95

## F

**Facilities Connection** 63

**Facility Checks** 64

**FastStop** 85

### Faults

light stack 101

over-voltage 98

soft start 97

troubleshooting 95

under-voltage 97

## G

### Gap

downstream 53

motor 49, 52

vehicle 70

**Getting Started** 29

### Grounding

static brushes 22

vehicles 22, 69

### Guideway

examples 24

identification 18

vehicle 69

**H****Hazards**

- electrical 12
- locations on system 31
- magnetic 13
- mechanical 11

**High-Level Controller**

- identification 19
- transport system layout 25

**Host Controller**

- configuration 67
- identification 19
- transport system layout 26

**I****Indicator**

- motor status 66
- network status 66

**Input Propulsion Power** 39

- limiting cycle 40
- PTC 40
- soft start 58

**Inspection**

- cables 89
- hardware 89

**Installation**

- check-out 63
- connect electronics 58
- ethernet cable 60
- magnet arrays 55
- motor 52
- motor orientation 63
- motor software 66
- motor status 66
- mount multiple magnet array 57
- mount single magnet array 57
- power cables 62
- power-up 64
- QS 150 System 47
- system testing 67
- troubleshooting 95
- vehicle 69, 80
- vehicle ground 69

**Internal Gap** 21**Internal Propulsion Power** 81**Internet Protocol**

- EtherNet/IP 84
- TCP/IP 84

**Inverter** 81**J****Jam**

- hindered signal 80
- vehicle 80

**L****Label**

- magnet array 38
- motor 33

**LED**

- motor status 66
- network status 66

**Limit Cycling**

- important 40
- soft start 58

**Logic Circuits** 81**M****Magnet Array**

- attractive force 21
- catalog number explanation 37
- cleaning 89
- cycle length 21
- description 21
- dimensions 38
- identification 18, 19
- installation 55
- mechanical drawing 38
- mechanical specifications 37
- mount multiple array 57
- mount single array 57
- seperating 56
- use 21

**Maintenance**

- cleaning 87
- inspection, cables 89
- inspection, hardware 89
- magnet arrays 89
- spray cleaning 88
- transport system 87
- wear surfaces 88

**Manual**

- prerequisites 7
- safety notices 8

**Mechanical Checks** 64**MMI-QS-CPAS-14AAxxx** 43**MMI-QS-CPCS-00XX000** 44**MMI-QS-CPDR-14AFxxx** 43**MMI-QS-CPDS-14AFxxx** 43**MMI-QS-CPRS-00XX000** 44**MMI-QS-CPSS-00AAxxx** 42**MMI-QS-CPSS-00XX000** 42**MMI-QS-CPTS-10AAxxx** 44**Motion**

- order 76
- profile 76
- troubleshooting 100

**Motor**

- block 77
- block acquisition 77
- block length 21
- block ownership 78
- block release 78
- catalog number explanation 32
- cogging 76
- communication connection 61
- connect electronics 58
- connections 41
- dimensions
  - 0.3 m 34
  - 0.5 m 34



- 1.0 m 34
- downstream gap 53
- electrical specifications 39
- ethernet connection 44
- identification 18, 19
- input voltage 32
- installation 52
- labels 33
- motor gap 53
- motor mount 49
- motors on a curve 53
- mounting 49, 52
- operation 76
- orientation 63
- output current 32
- power management 82
- programming 91
- regenerated power 82
- replacement 89
- shipping 92
- software 66
- status indicator 66
- transport system layout 19
- Motor Blocks** 21
- Motor Cogging** 76
- Motor Controller** 24
- Motor Gap** 53
- Motor Mount**
  - identification 18
  - installation 49
  - requirements 51
  - types 49
- Motor Status** 66
- Motors on a Curve** 53
- Mounting Clearance**
  - cable 35
  - motor 35

## N

- NCHost TCP/IP Interface Utility** 84
- Network**
  - identification 19
  - transport system layout 26
  - troubleshooting 95
- Network Status** 66
- Node Controller** 25
  - identification 19
  - IP address 84
  - overview 84
  - transport system layout 25
  - troubleshooting 99
- Node Controller Configuration File**
  - define 18
  - node controller port 61
  - upload 67
- Nodes**
  - descriptions 24
  - transport system layout 24

## O

- Obstruction, vehicle** 80

## Operation

- monitoring 84
- motor 76
- motor block 77
- motor cogging 76
- shut down 86
- start up 85, 87
- troubleshooting 95

## P

### Paths

- transport system layout 23

### Personnel Safety

 8

### Power Cables

- identification 19
- installation 62
- motor power 41

### Power Regeneration

 81

### Power Status

 66

### Power Supply

- identification 19
- transport system layout 26
- troubleshooting 95

### Pre-operation Checks

 64

### Propulsion Input Power

- limiting cycle 40
- vehicle tracking 72
- voltages 81

## Q

### QS 150 System

- additional components 26
- anti-collision 78
- block wiring diagram 27
- checks 64
- components 18, 19
- description 17
- design 47
- electrical 81
- electrical wiring 62
- getting started 29
- guideways 24
- installation 47
- magnet array 21
- motor blocks 21, 77
- motor connections 39
- motor controller 24
- motor replacement 90
- motors 19
- node controller 84
- power management 82
- power supply 26
- propulsion voltage 27
- shut down 86
- software 66
- software overview 28
- start up 85
- switches 23
- system testing 67
- troubleshooting 95
- vehicle queue 80
- vehicles 22

**QuickStick 150** see **QS 150**

**R**

**Related Documentation** 15  
**Repair** 90  
**Replacement** 90  
**Rockwell Automation**  
 Sales 92  
**RS-422**  
 connections 60

**S**

**Safe Stopping Distance** 79  
**Safety**  
 alert types 7  
 equipment 9  
 hazardous points 31  
 notices 7, 8, 11, 12, 13  
 personnel 8  
 separate magnet array 56  
 symbols 10  
**Shipping** 92  
**Shut Down** 86  
**Single Array Vehicle** 70  
**Single Magnet Array**  
 alignment in curves 68  
**Soft Start**  
 limit cycling 58  
**Software** 66  
 installation, motors 67  
 overview 28  
 programming motors 91  
 types 28  
**Specifications**  
 electrical 39  
 magnet array 37  
 motor 32  
**Spray Cleaning** 88  
**Stall Current** 39  
**Start Up** 85  
**Static Brushes** 22, 69  
**Stator Length** 21  
**Straight Trac Configuration** 54  
**Switch**  
 definition 23  
 transport system layout 19  
 vehicle 81  
**System**  
 power-up 64  
 testing 67  
 wiring block diagram 27  
**System Testing** 67

**T**

**TCP/IP Interface Utility**  
 using 67, 91  
**Thrust Limits** 79  
**Tools**  
 installation 47  
 unpacking 48  
**Track**  
 curve 54  
 identification 18  
 straight 54

**Track Display** 84  
**Transport System Layout**  
 high-level controller 25  
 host controller 26  
 motors 19  
 network 26  
 node controllers 25  
 nodes 24  
 paths 23  
 power supplies 26  
 switches 19  
**Troubleshooting**  
 communication 99  
 initial 95  
 light stack 101  
 motion 100  
 node controller 99  
 over-voltage 98  
 power 95  
 under-voltage 97  
 warnings and faults 97

**U**

**Unpacking**  
 packing checklist 48  
 packing materials 49  
 warnings 48

**V**

**Vehicle**  
 anti-collision 78  
 configuration  
 dual-array 70  
 single array 70  
 configuration, dual-array 56  
 definition 22  
 detected 81  
 dual-array 56  
 gap 70  
 ground 69  
 hindered signal 80  
 identification 18  
 installation 71  
 jammed 80  
 locating during startup 81  
 lost signal 72  
 mounting 69  
 movement 79  
 obstructed 80  
 propulsion power 72  
 queue 80  
 thrust limits 79  
 tracking 72  
 wheel and roller 70  
**Voltage Drop** 81

**W**

**Web Interface**  
 program motors 67  
 using 91  
**Wiring**  
 motor power 62  
 transport system layout 26

**Notes:**

# Rockwell Automation Support

Use these resources to access support information.

<b>Technical Support Center</b>	Find help with how-to videos, FAQs, chat, user forums, and product notification updates.	<a href="http://rok.auto/support">rok.auto/support</a>
<b>Knowledgebase</b>	Access Knowledgebase articles.	<a href="http://rok.auto/knowledgebase">rok.auto/knowledgebase</a>
<b>Local Technical Support Phone Numbers</b>	Locate the telephone number for your country.	<a href="http://rok.auto/phonesupport">rok.auto/phonesupport</a>
<b>Literature Library</b>	Find installation instructions, manuals, brochures, and technical data publications.	<a href="http://rok.auto/literature">rok.auto/literature</a>
<b>Product Compatibility and Download Center (PCDC)</b>	Download firmware, associated files (such as AOP, EDS, and DTM), and access product release notes.	<a href="http://rok.auto/pcdc">rok.auto/pcdc</a>

## Documentation Feedback

Your comments help us serve your documentation needs better. If you have any suggestions on how to improve our content, complete the form at [rok.auto/docfeedback](http://rok.auto/docfeedback).

## Waste Electrical and Electronic Equipment (WEEE)



At the end of life, this equipment should be collected separately from any unsorted municipal waste.

Rockwell Automation maintains current product environmental compliance information on its website at [rok.auto/pec](http://rok.auto/pec).





Allen-Bradley, expanding human possibility, MagneMotion, MagneMover, MML, MM LITE, QuickStick, Rockwell Automation, and Stratix are trademarks of Rockwell Automation, Inc.

EtherNet/IP is a trademark of ODVA, Inc.

Bosch and Rexroth are trademarks of Bosch Company.

Trademarks not belonging to Rockwell Automation are property of their respective companies.

Rockwell Otomasyon Ticaret A.Ş. Kar Plaza İş Merkezi E Blok Kat:6 34752, İçerenköy, İstanbul, Tel: +90 (216) 5698400 EEE Yönetmeliğine Uygundur

Connect with us.    

**rockwellautomation.com** \_\_\_\_\_ expanding **human possibility**<sup>®</sup>

AMERICAS: Rockwell Automation, 1201 South Second Street, Milwaukee, WI 53204-2496 USA, Tel: (1) 414.382.2000, Fax: (1) 414.382.4444

EUROPE/MIDDLE EAST/AFRICA: Rockwell Automation NV, Pegasus Park, De Kleetlaan 12a, 1831 Diegem, Belgium, Tel: (32) 2 663 0600, Fax: (32) 2 663 0640

ASIA PACIFIC: Rockwell Automation, Level 14, Core F, Cyberport 3, 100 Cyberport Road, Hong Kong, Tel: (852) 2887 4788, Fax: (852) 2508 1846

UNITED KINGDOM: Rockwell Automation Ltd. Pitfield, Kiln Farm Milton Keynes, MK11 3DR, United Kingdom, Tel: (44)(1908) 838-800, Fax: (44)(1908) 261-917

Publication MMI-UM047B-EN-P - August 2023

Supersedes Publication MMI-UM047A-EN-PI May 2023

Copyright © 2023 Rockwell Automation, Inc. All rights reserved. Printed in the U.S.A.