

2100 Eddy Current Probe Systems Specifications

Catalog Numbers EK-21 series, EK-48 series

Topic	Page
Non-contact Pick-up Probe System	3
Wiring Guidelines	4
2100 Series Probes Specifications	5
2100 Series Catalog Numbers	7
Accessories	16

The 2100 series probes come with tip diameters from 5...50 mm (0.20... 1.97 in.) that satisfy API 670 requirements with respect to scale factor error, interchangeability, and sensor size. The 2100 system is suited for vibration, speed/acceleration, rotor/position, and differential expansion measurements.

IMPORTANT The 2100 series probes, extension cables, and drivers are API-670 compliant in all respects except for tolerance to environments containing hydrogen sulfide and ammonia.

Important User Information

Solid-state equipment has operational characteristics differing from those of electromechanical equipment. Safety Guidelines for the Application, Installation and Maintenance of Solid State Controls (publication [SGI-1.1](#) available from your local Rockwell Automation sales office or online at <http://www.rockwellautomation.com/literature/>) describes some important differences between solid-state equipment and hard-wired electromechanical devices. Because of this difference, and also because of the wide variety of uses for solid-state equipment, all persons responsible for applying this equipment must satisfy themselves that each intended application of this equipment is acceptable.

In no event will Rockwell Automation, Inc. be responsible or liable for indirect or consequential damages resulting from the use or application of this equipment.

The examples and diagrams in this manual are included solely for illustrative purposes. Because of the many variables and requirements associated with any particular installation, Rockwell Automation, Inc. cannot assume responsibility or liability for actual use based on the examples and diagrams.

No patent liability is assumed by Rockwell Automation, Inc. with respect to use of information, circuits, equipment, or software described in this manual.

Reproduction of the contents of this manual, in whole or in part, without written permission of Rockwell Automation, Inc., is prohibited.

Throughout this manual, when necessary, we use notes to make you aware of safety considerations.



WARNING: Identifies information about practices or circumstances that can cause an explosion in a hazardous environment, which may lead to personal injury or death, property damage, or economic loss.



ATTENTION: Identifies information about practices or circumstances that can lead to personal injury or death, property damage, or economic loss. Attentions help you identify a hazard, avoid a hazard, and recognize the consequence



SHOCK HAZARD: Labels may be on or inside the equipment, for example, a drive or motor, to alert people that dangerous voltage may be present.



BURN HAZARD: Labels may be on or inside the equipment, for example, a drive or motor, to alert people that surfaces may reach dangerous temperatures.

IMPORTANT

Identifies information that is critical for successful application and understanding of the product.

Rockwell Automation, Rockwell Software, Allen-Bradley, and Tech-Connect are trademarks of Rockwell Automation, Inc.

Trademarks not belonging to Rockwell Automation are property of their respective companies.

Non-contact Pick-up Probe System

A non-contact pick-up probe system is composed of three components.

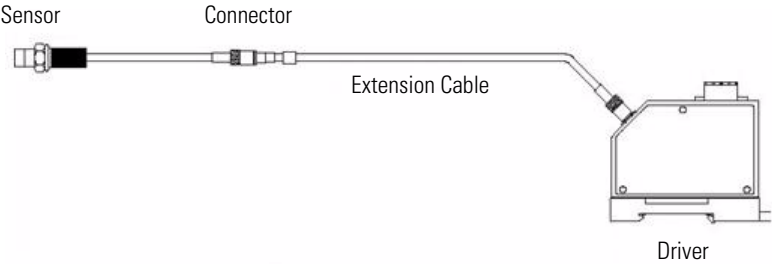

Component	Description
Non-contact pick-up probe	<p>The non-contact pick-up probe is an encapsulated wire configuration that reads the relative position of the equipment by introducing eddy currents into the target material and measuring the change in the current as the target surface moves. The energy loss into the target increases or decreases as the target moves nearer to or farther away from the probe. The change in energy loss is detected as a change in the modulated signal, which provides a voltage proportional to the gap between the probe tip and the target. This signal is fed to the monitoring system, providing a continuous and very accurate measure of the relative distance to the target surface.</p> <p>The tip diameter characterizes the probe. In general, the wider the tip, the greater the range that the probe can sense. Select other characteristics, such as the body length and the thread size, based on the application.</p>
Extension cable	<p>The extension cable provides flexibility for placement of the probe by allowing extended lengths between the driver and the non-contact pick-up. A variety of Teflon-insulated and Armor-coaxial extension cables adapt the sensor system to most installations. The extension cables are electrically matched to the selected probe system.</p>
Driver	<p>The driver systems are case isolated and can be DIN-rail or panel mounted. The stainless-steel probe drivers provide the radio frequency that powers the probe system. The driver is the primary component responsible for signal conditioning, providing accurate linearity over the operating range of the system.</p> <p>The 2100 series drivers are not isolated. Mount the drivers with a isolating pad (included with the driver), or install them in an isolated enclosure. The 2100 series drivers are panel mounted.</p>

Wiring Guidelines

When wiring the probe driver to a monitor, consider the following recommendations:

- Use only a good quality instrumentation cable with three conductor stranded wire and shield. Also consider the following:
 - Wire should be rated with a maximum capacitance of 60 pF/ft (197 pF/m) and inductance of 0.3 μ H/ft (1 μ H/m).
 - Use wire with insulation suitable for the environment and with adequate tensile strength and flexibility for the application.
 - Use wire with a foil shield for use in environments where radio frequency interference (RFI) may be present.
 - Use wire with a braid shield for environments where electromagnetic interference (EMI) may be present.
 - Use 0.82...2.08 mm² (18...14 AWG) gauge wire.
- Make sure the wire is isolated from power cables and any other wiring that may be transmitting high voltage power or control signals.
- Any cable transmitting pulse-type vibration signals, such as a phase marker or speed pulse, should be isolated from displacement and vibration signals.
- Run wire within conduit and cable trays and as per any local electrical codes.
- Do not exceed 500 m (1640 ft). However, limiting the length to 300 m (984 ft) guarantees that vibration signals in the 0...10 kHz frequency range will be transmitted with minimal attenuation. When longer lengths are needed, the capacitance of the cable and the desired frequency response of the system must be considered.
- In most cases, make sure that the cable shield is grounded at only one point, generally at the monitor.

2100 Series Probes Specifications

Table 1 - Individual Technical Specifications

Product Feature	5 mm (0.20 in.)	8 mm (0.31 in.)	11 mm (0.43 in.)	18 mm (0.71 in.)	25.4 mm (1 in.)	50 mm (1.97 in.)
Applications	Vibration and speed		Speed and acceleration	Thrust position	Differential expansion	
Linear range, approx. ⁽¹⁾	4...80 mils (0.1...2.3 mm)		8...188 mils (0.2...4.7 mm)	12...248 mils (0.3...6.3 mm)	120...651 mils (3...16.5 mm)	120...1142 mils (3...29 mm)
Sensitivity ⁽¹⁾	200 mV/mil (787 mV/100µm)		10.0 mV/mil (394 mV/100 µm)	63.5 mV/mil (2.5V/mm)	20.3 mV/mil (0.8V/mm)	10.15 mV/mil (0.4V/mm)
Linearity (if calibrated as a system) ⁽¹⁾	±0.8 mils of 200 mV/mil		±2.9 mils of 100 mV/mil	±3.5 mils	±7.8 mils	±9.8 mils
Accuracy when components are interchangeable	±10% of 200 mV/mil		±4.7 mils		±10.6 mils	±15.7 mils
Frequency response	DC to 20 kHz (-3 dB)		DC to 10 kHz (-3 dB)		DC to 3 kHz (-3 dB)	

(1) Applies at 25 °C (77 °F) with -24V DC power supply, load resistance 10 kΩ, and AISI 4140 steel target (thickness ≥ 5 mm).

Table 2 - Common Technical Specifications

Attribute	2100 Series Probes
Standard calibration	AISI 4140 (JIS SCM440) steel flat surface
Scale factor tolerance ⁽¹⁾	Within ±5% of 200 mV/mil (if calibrated as a system)
Sensitivity error ⁽¹⁾	Within ±4%
Power supply	-17.5...-26V DC
Output voltage, approx., max	-22V DC @-24V DC
Current consumption @ 10 kΩ load resistance, max	-16 mA
Output impedance	50 Ω
Cable tip diameter, approx., max	6 mm (0.24 in.)
Connector tip diameter, approx., max	9.5 mm (0.37 in.)
Connector material	Stainless steel, gold plated SMA connector
Sensor cable length	1 m (3.28 ft)
System cable length	5 m (16.40 ft): ±10% 9 m (29.53 ft): ±10%

(1) Applies at 25 °C (77 °F) with -24V DC power supply, load resistance 10 kΩ, and AISI 4140 steel target (thickness ≥ 5 mm).

Table 3 - Environmental Specifications

Attribute	2100 Series Probes
Operating temperature	
Sensor	-40...177 °C (-40...350 °F)
Extension cable and connector, max	125 °C (257 °F)
Driver	-38...80 °C (-36...176 °F)
Operating humidity	30...95% RH (noncondensing, nonsubmerged)

Table 4 - Certifications

Certification ^{(1) (2)}	2100 Series Probes
CSA	System <ul style="list-style-type: none"> Ex ia IIC T4, AEx ia IIC T4, Class I Zone 0/1 or Class 1 Division 1; Groups A, B, C and D, when installed with shunt diode safety barrier per drawing ETK51271-HAZ, sheet 1 Entity <ul style="list-style-type: none"> Ex ia IIC T4, AEx ia IIC T4, Class I Zone 0/1 or Class 1 Division 1; Groups A, B, C and D, when installed with associated equipment per drawing ETK51270-HAZ Class 1 Division 2; Groups A, B, C and D, may be installed without barriers per drawing ETK51270-HAZ
CE	European Union EMC Directive 2004/108/EC
C-Tick	Australian Radio Communications Act. Compliant with AS/NZS 2064, Industrial Emissions
EX	European Union ATEX Directive 94/9/EC II 1 G, Ex ia IIC T4. EC certificate LCIE 07 ATEX 6051 X, when connected to associated intrinsically-safe equipment in accordance with drawing ETK51271-HAZ, sheet 2

(1) When marked. See the Product Certification link at <http://www.ab.com> for Declarations of Conformity, Certificates, and other certification details.

(2) Hazardous Area Approvals (when product or package is marked). Multiple approvals for hazardous areas certified by Canadian Standards Association (CSA/NRTL/C) in North America and by LCIE (2007) in Europe.

2100 Series Catalog Numbers

Catalog numbers consist of various characters, each of which identifies a specific option for the probe system. Use the following tables to determine the catalog number for your probe system.

2100 Series Probes

$$21 \frac{11}{a} - \frac{4000110}{b \ c \ d \ e}$$

a	
Probe Diameter	
Code	Description
01...04	5 mm (0.20 in.)
05...08	8 mm (0.31 in.)
11...14	11 mm (0.43 in.)
18...19	18 mm (0.71 in.)
25...27	25.4 mm (1 in.)
50	50 mm (1.97 in.)

b	
Body Length	
Code	Description
30	30 mm (1.18 in.)
40	40 mm (1.57 in.)
50	50 mm (1.97 in.)
70	70 mm (2.76 in.)
76	76 mm (2.99 in.)
90	90 mm (3.54 in.)
120	120 mm (4.72 in.)
150	150 mm (5.91 in.)

c	
Unthreaded Length	
Code	Description
00	0 or 5 mm (0 or 0.20 in.) depending on probe

d
Reserved
=1

e	
Cable Length	
Code	Description
1 or 10	1.0 m (3.28 ft)
5 or 05	0.5 m (1.64 ft)

Table 5 - 2100 Series Standard Mount Probes with 1.0 m (3.28 ft) Cable

Cat. No.	Description
EK-2101-120-03-1-1	5 mm (0.20 in.) probe tip, standard cable, 1/4-28 UNF thread, 120 mm (4.27 in.) length
EK-2101-150-03-1-1	5 mm (0.20 in.) probe tip, standard cable, 1/4-28 UNF thread, 150 mm (5.91 in.) length
EK-2101-30-03-1-10	5 mm (0.20 in.) probe tip, standard cable, 1/4-28 UNF thread, 30 mm (1.18 in.) length
EK-2101-50-03-1-10	5 mm (0.20 in.) probe tip, standard cable, 1/4-28 UNF thread, 50 mm (1.97 in.) length
EK-2101-70-03-1-10	5 mm (0.20 in.) probe tip, standard cable, 1/4-28 UNF thread, 70 mm (2.76 in.) length
EK-2101-90-03-1-10	5 mm (0.20 in.) probe tip, standard cable, 1/4-28 UNF thread, 90 mm (3.54 in.) length
EK-2102-120-03-1-1	5 mm (0.20 in.) probe tip, armored cable, 1/4-28 UNF thread, 120 mm (4.27 in.) length
EK-2102-150-03-1-1	5 mm (0.20 in.) probe tip, armored cable, 1/4-28 UNF thread, 150 mm (5.91 in.) length
EK-2102-30-03-1-10	5 mm (0.20 in.) probe tip, armored cable, 1/4-28 UNF thread, 30 mm (1.18 in.) length
EK-2102-50-03-1-10	5 mm (0.20 in.) probe tip, armored cable, 1/4-28 UNF thread, 50 mm (1.97 in.) length

Table 5 - 2100 Series Standard Mount Probes with 1.0 m (3.28 ft) Cable

Cat. No.	Description
EK-2102-70-03-1-10	5 mm (0.20 in.) probe tip, armored cable, 0.25-28 UNF thread, 70 mm (2.76 in.) length
EK-2102-90-03-1-10	5 mm (0.20 in.) probe tip, armored cable, 0.25-28 UNF thread, 90 mm (3.54 in.) length
EK-2103-120-03-1-1	5 mm (0.20 in.) probe tip, standard cable, M8x1 thread, 120 mm (4.72 in.) length
EK-2103-150-03-1-1	5 mm (0.20 in.) probe tip, standard cable, M8x1 thread, 150 mm (5.91 in.) length
EK-2103-30-03-1-10	5 mm (0.20 in.) probe tip, standard cable, M8x1 thread, 30 mm (1.18 in.) length
EK-2103-50-03-1-10	5 mm (0.20 in.) probe tip, standard cable, M8x1 thread, 50 mm (1.97 in.) length
EK-2103-70-03-1-10	5 mm (0.20 in.) probe tip, standard cable, M8x1 thread, 70 mm (2.76 in.) length
EK-2103-90-03-1-10	5 mm (0.20 in.) probe tip, standard cable, M8x1 thread, 90 mm (3.54 in.) length
EK-2104-120-03-1-1	5 mm (0.20 in.) probe tip, armored cable, M8x1 thread, 120 mm (4.72 in.) length
EK-2104-150-03-1-1	5 mm (0.20 in.) probe tip, armored cable, M8x1 thread, 150 mm (5.91 in.) length
EK-2104-30-03-1-10	5 mm (0.20 in.) probe tip, armored cable, M8x1 thread, 30 mm (1.18 in.) length
EK-2104-50-03-1-10	5 mm (0.20 in.) probe tip, armored cable M8x1 thread, 50 mm (1.97 in.) length
EK-2104-70-03-1-10	5 mm (0.20 in.) probe tip, armored cable, M8x1 thread, 70 mm (2.76 in.) length
EK-2104-90-03-1-10	5 mm (0.20 in.) probe tip, armored cable, M8x1 thread, 90 mm (3.54 in.) length
EK-2105-120-00-1-1	8 mm (0.31 in.) probe tip, standard cable, 3/8-24 UNF thread, 120 mm (4.72 in.) length
EK-2105-150-00-1-1	8 mm (0.31 in.) probe tip, standard cable, 3/8-24 UNF thread, 150 mm (5.91 in.) length
EK-2105-30-00-1-10	8 mm (0.31 in.) probe tip, standard cable, 3/8-24 UNF thread, 30 mm (1.18 in.) length
EK-2105-50-00-1-10	8 mm (0.31 in.) probe tip, standard cable, 3/8-24 UNF thread, 50 mm (1.97 in.) length
EK-2105-70-00-1-10	8 mm (0.31 in.) probe tip, standard cable, 3/8-24 UNF thread, 70 mm (2.76 in.) length
EK-2105-90-00-1-10	8 mm (0.31 in.) probe tip, standard cable, 3/8-24 UNF thread, 90 mm (3.54 in.) length
EK-2106-120-00-1-1	8 mm (0.31 in.) probe tip, armored cable, 3/8-24 UNF thread, 120 mm (4.72 in.) length
EK-2106-150-00-1-1	8 mm (0.31 in.) probe tip, armored cable, 3/8-24 UNF thread, 150 mm (5.91 in.) length
EK-2106-30-00-1-10	8 mm (0.31 in.) probe tip, armored cable, 3/8-24 UNF thread, 30 mm (1.18 in.) length
EK-2106-50-00-1-10	8 mm (0.31 in.) probe tip, armored cable, 3/8-24 UNF thread, 50 mm (1.97 in.) length
EK-2106-70-00-1-10	8 mm (0.31 in.) probe tip, armored cable, 3/8-24 UNF thread, 70 mm (2.76 in.) length
EK-2106-90-00-1-10	8 mm (0.31 in.) probe tip, armored cable, 3/8-24 UNF thread, 90 mm (3.54 in.) length
EK-2107-120-00-1-1	8 mm (0.31 in.) probe tip, standard cable, M10x1 thread, 120 mm (4.72 in.) length
EK-2107-150-00-1-1	8 mm (0.31 in.) probe tip, standard cable, M10x1 thread, 150 mm (5.91 in.) length
EK-2107-30-00-1-10	8 mm (0.31 in.) probe tip, standard cable, M10x1 thread, 30 mm (1.18 in.) length
EK-2107-50-00-1-10	8 mm (0.31 in.) probe tip, standard cable, M10x1 thread, 50 mm (1.97 in.) length
EK-2107-70-00-1-10	8 mm (0.31 in.) probe tip, standard cable, M10x1 thread, 70 mm (2.76 in.) length
EK-2107-90-00-1-10	8 mm (0.31 in.) probe tip, standard cable, M10x1 thread, 90 mm (3.54 in.) length
EK-2108-120-00-1-1	8 mm (0.31 in.) probe tip, armored cable, M10x1 thread, 120 mm (4.72 in.) length
EK-2108-150-00-1-1	8 mm (0.31 in.) probe tip, armored cable, M10x1 thread, 150 mm (5.91 in.) length
EK-2108-30-00-1-10	8 mm (0.31 in.) probe tip, armored cable, M10x1 thread, 30 mm (1.18 in.) length
EK-2108-50-00-1-10	8 mm (0.31 in.) probe tip, armored cable, M10x1 thread, 50 mm (1.97 in.) length
EK-2108-70-00-1-10	8 mm (0.31 in.) probe tip, armored cable, M10x1 thread, 70 mm (2.76 in.) length
EK-2108-90-00-1-10	8 mm (0.31 in.) probe tip, armored cable, M10x1 thread, 90 mm (3.54 in.) length

Table 6 - 2100 Series Standard Long Range Probes with 1.0 m (3.28 ft) Cable

Cat. No.	Description
EK-2111-40-00-1-10	11 mm (0.43 in.) probe tip, standard cable, 1/2-20 UNF thread, 40 mm (1.57 in.) length
EK-2112-40-00-1-10	11 mm (0.43 in.) probe tip, armored cable, 1/2-20 UNF thread, 40 mm (1.57 in.) length
EK-2113-40-00-1-10	11 mm (0.43 in.) probe tip, standard cable, M14x1.5 thread, 40 mm (1.57 in.) length
EK-2114-40-00-1-10	11 mm (0.43 in.) probe tip, armored cable, M14x1.5 thread, 40 mm (1.57 in.) length
EK-2118-50-00-1-10	18 mm (0.71 in.) probe tip, armored cable, 7/8-14 UNF thread, 50 mm (1.97 in.) length
EK-2119-50-00-1-10	18 mm (0.71 in.) probe tip, armored cable, M20x15 thread, 50 mm (1.97 in.) length
EK-2125-50-00-1-10	25.4 mm (1 in.) probe tip, armored cable, jam nut mount, 1 1/4-12 UNF thread, 50 mm (1.97 in.) length
EK-2126-50-00-1-10	25.4 mm (1 in.) probe tip, armored cable, jam nut mount, M50x1.5 thread, 50 mm (1.97 in.) length
EK-2127-76-00-1-10	25.4 mm (1 in.) probe tip, armored cable, side exit sensor 4-M6 depth 14 mount, 76 mm (2.99 in.) length
EK-2150-50-00-1-10	50 mm (1.97 in.) probe tip, armored cable, 1-12 UNF thread, 50 mm (1.97 in.) length
EK-2151-50-00-1-10	50 mm (1.97 in.) probe tip, armored cable, M24x1.5 thread, 50 mm (1.97 in.) length

Table 7 - 2100 Series Standard Mount Right Angle Probes with 1.0 m (3.28 ft) Cable

Cat. No.	Description
EK-2127-76-00-1-10	25.4 mm (1 in.) probe tip, armored cable, side exit sensor 4-M6 Depth 14 mount, 76 mm (2.99 in.) length

Table 8 - 2100 Series Reverse Mount Probes

Cat. No.	Description
EK-2109-30-05-1-05	8 mm (0.31 in.) probe tip, 0.5 m (1.64 ft) standard cable, 3/8-24 UNF thread, 30 mm (1.18 in.) length
EK-2109-30-05-1-10	8 mm (0.31 in.) probe tip, 1.0 m (3.28 ft) standard cable, 3/8-24 UNF thread, 30 mm (1.18 in.) length
EK-2110-30-05-1-05	8 mm (0.31 in.) probe tip, 0.5 m (1.64 ft) standard cable, M10x1 thread, 30 mm (1.18 in.) length
EK-2110-30-05-1-10	8 mm (0.31 in.) probe tip, 1.0 m (3.28 ft) standard cable, M10x1 thread, 30 mm (1.18 in.) length

The following probes are API-670 compliant in all respects, except for tolerance to environments containing hydrogen sulfide and ammonia.

Table 9 - 2100 Series API-670 Compliant Probes with 1.0 m (3.28 ft) Cable

Cat. No.	Description
EK-2195-40-00-1-10	API compliant, 8 mm (0.31 in.) probe tip, standard Cable, 3/8-24 UNF thread 40 mm (1.57 in.) length Use with 2100 series API compliant extension cable and driver
EK-2196-40-00-1-10	API compliant, 8 mm (0.31 in.) probe tip, armored cable, 3/8-24 UNF thread, 40 mm (1.57 in.) length Use with 2100 series API compliant extension cable and driver

2100 Series Extension Cables

217⁰⁰⁴⁰_{ab c}

a	
Probe Diameter	
Code	Description
0	5 or 8 mm (0.20. or 0.31 in.)
1	11 mm (0.43 in.)
2	18 mm (0.71 in.)
3	25.4 mm (1 in.)
4	50 mm (1.97 in.)

b	
Armored Cable	
Code	Description
0	Not armored
1	Armored

c	
Cable Length	
Code	Description
40	4 m (13 ft)
45	4.5 m (15 ft)
80	8 m (26 ft)
85	8.5 m (28 ft)

Table 10 - 2100 Series Extension Cables

Cat. No.	Description
EK-2170-0-40	Use with 5 or 8 mm (0.20 or 0.31 in.) tip 2100 series probes, 4 m (13 ft)
EK-2170-0-45	Use with 5 or 8 mm (0.20 or 0.31 in.) tip 2100 series probes, 4.5 m (15 ft)
EK-2170-0-80	Use with 5 or 8 mm (0.20 or 0.31 in.) tip 2100 series probes, 8 m (26 ft)
EK-2170-0-85	Use with 5 or 8 mm (0.20 or 0.31 in.) tip 2100 series probes, 8.5 m (28 ft)
EK-2170-1-40	Use with 5 or 8 mm (0.20 or 0.31 in.) tip 2100 series probes, 4 m (13 ft), armored
EK-2170-1-45	Use with 5 or 8 mm (0.20 or 0.31 in.) tip 2100 series probes, 4.5 m (15 ft), armored
EK-2170-1-80	Use with 5 or 8 mm (0.20 or 0.31 in.) tip 2100 series probes, 8 m (26 ft), armored
EK-2171-0-40	Use with 11 mm (0.43 in.) tip 2100 series probes, 4 m (13 ft)
EK-2171-0-80	Use with 11 mm (0.43 in.) tip 2100 series probes, 8 m (26 ft)
EK-2171-1-40	Use with 11 mm (0.43 in.) tip 2100 series probes, 4 m (13 ft), armored
EK-2171-1-80	Use with 11 mm (0.43 in.) tip 2100 series probes, 8 m (26 ft), armored
EK-2172-1-40	Use with 18 mm (0.71 in.) tip 2100 series probes, 4 m (13 ft), armored
EK-2172-1-80	Use with 18 mm (0.71 in.) tip 2100 series probes, 8 m (26 ft), armored
EK-2173-1-40	Use with 25.4 mm (1 in.) tip 2100 series probes, 4 m (13 ft), armored
EK-2173-1-80	Use with 25.4 mm (1 in.) tip 2100 series probes, 8 m (26 ft), armored
EK-2174-1-40	Use with 50 mm (1.97 in.) tip 2100 series probes, 4 m (13 ft), armored
EK-2174-1-80	Use with 50 mm (1.97 in.) tip 2100 series probes, 8 m (26 ft), armored

These extension cables are API-670 compliant in all respects, except for tolerance to environments containing hydrogen sulfide and ammonia.

Table 11 - 2100 Series API-670 Extension Cables

Cat. No.	Description
EK-2190-0-40	Use with API compliant 8 mm (0.31 in.) tip 2100 series probes, 4 m (13 ft)
EK-2190-0-80	Use with API compliant 8 mm (0.31 in.) tip 2100 series probes, 8 m (26 ft)
EK-2190-1-80	Use with API compliant 8 mm (0.31 in.) tip 2100 series probes, 8 m (26 ft), armored

2100 Series Probe Drivers

$$21 \frac{085}{a b} - 001$$

a		b	
Probe Diameter		System Length	
Code	Description	Code	Description
08	5 or 8 mm (0.20. or 0.31 in.)	5	5 m (16 ft)
11	11 mm (0.43 in.)	9	9 m (29 ft)
18	18 mm (0.71 in.)		
25	25.4 mm (1 in.)		
50	50 mm (1.97 in.)		

Table 12 - 2100 Series Probe Drivers

Cat. No.	Description
EK-2108-5-001	Use with 5 or 8 mm (0.20 or 0.31 in.) tip probes and 5 m (16 ft) total length systems
EK-2108-9-001	Use with 5 or 8 mm (0.20 or 0.31 in.) tip probes and 9 m (29 ft) total length systems
EK-2111-5-001	Use with 11 mm (0.43 in.) tip probes and 5 m (16 ft) total length systems
EK-2111-9-001	Use with 11 mm (0.43 in.) tip probes and 9 m (29 ft) total length systems
EK-2118-5-001	Use with 18 mm (0.71 in.) tip probes and 5 m (16 ft) total length systems
EK-2118-9-001	Use with 18 mm (0.71 in.) tip probes and 9 m (29 ft) total length systems
EK-2125-5-001	Use with 25.4 mm (1 in.) tip probes and 5 m (16 ft) total length systems
EK-2125-9-001	Use with 25.4 mm (1 in.) tip probes and 9 m (29 ft) total length systems
EK-2150-5-001	Use with 50 mm (1.97 in.) tip probes and 5 m (16 ft) total length systems
EK-2150-9-001	Use with 50 mm (1.97 in.) tip probes and 9 m (29 ft) total length systems

These probe drivers above are API-670 compliant in all respects, except for tolerance to environments containing hydrogen sulfide and ammonia.

Table 13 - 2100 Series API-670 Probe Drivers

Cat. No.	Description
EK-2198-5-001	Use with 8 mm (0.31 in.) tip API compliant probes and 5 m (16 ft) total length systems
EK-2198-9-001	Use with 8 mm (0.31 in.) tip API compliant probes and 9 m (29 ft) total length systems

2100 Series Long-range Calibrated Systems

Two calibrated systems are available for differential expansion applications on large steam turbines. Differential expansion is the difference between the thermal growth of the rotor and the thermal growth of the turbine case. Monitoring differential expansion is critical during a turbine cold start-up. A common steam turbine has a thick, heavy case, and a lighter, hollow rotor, so the case will grow slower than the rotor. Therefore operators must manage how fast the machine heats so that the case and rotor do not make contact. To monitor this, transducers are typically placed on a collar or ramp that has been machined onto the turbine. Each system is comprised of a probe, an extension cable, and a driver.

Table 14 - Technical Specifications

Attribute	EK-48484	EK-48486
Description	Differential expansion, 250 mil reverse mount system	Differential expansion, 500 mil standard system
Probe	18 mm (0.71 in.) diameter tip, reverse mount with 3/8-24 UNF thread and 1 m (3.28 ft) standard cable	25.4 mm (1 in.) diameter tip with right angle mounting plate and 1 m (3.28 ft) armored cable
Extension Cable	4.0 meter unarmored extension cable	8.0 meter armored extension cable
Driver	Driver calibrated for 18 mm (0.71 in.) probe and 5 m (16 ft) electrical (system) length	Driver calibrated for 25.4 mm (1 in.) probe and 9 m (29 ft) electrical (system) length
Range	24...260 mils (0.6...6.6 mm)	531 mils (13.5 mm)
Sensitivity ⁽¹⁾	63.5 mV/mil (2.5 V/mm) ±4%	20.3 mV/mil (0.8 V/mm) ±4%
Linearity ⁽¹⁾	±3.5 mils (89 µm)	±7.8 mils (200 µm)
Frequency Response	DC to 10 kHz (-3dB)	DC to 3 kHz (-3dB)
System cable length	5 m (16 ft) ±10%	9 m (29 ft) ±10%
Output impedance	50 Ω	50 Ω
Power supply	24V DC ±10% @ 13 mA	24V DC ±10% @ 15 mA

(1) Applies at 25 °C (77 °F) with -24V DC power supply, load resistance 10 kΩ, and AISI 4140 steel target (thickness ≥ 5 mm).

Table 15 - Environmental Specifications

Attribute	EK-48484	EK-48486
Operating temperature		
Probe	-40...125 °C (-40...257 °F)	-40...125 °C (-40...257 °F)
Extension cable and connector	125 °C (257 °F)	125 °C (257 °F)
Driver	-38...80 °C (-36...176 °F)	-38...80 °C (-36...176 °F)
Operating humidity	0...95% noncondensing, nonsubmerged	0...95% noncondensing, nonsubmerged

Table 16 - EK-48484 Reverse Mount System Drawings

Description	Drawing
<p>Probe</p> <p>18 mm (0.71 in.) diameter tip, epoxy sealed, reverse mount probe with 3/8-24 UNF threaded body and 1 m (3.28 ft) cable</p>	
<p>Extension cable</p> <p>4 m (13 ft) standard Teflon extension cable</p>	
<p>Driver</p> <p>Aluminum driver (oscillator-demodulator) calibrated for 18 mm (0.71 in.) probe and 5 m (16 ft) electrical (system) length</p>	

Table 17 - EK-48486 Standard System Drawings

Description	Drawing
<p>Probe</p> <p>25.4 mm (1 in.) diameter tip, epoxy sealed, probe with right angle mounting plate and 1 m (3.28 ft) armored cable</p>	
<p>Extension cable</p> <p>8 m (26 ft) armored Teflon extension cable</p>	
<p>Driver</p> <p>Aluminum driver (oscillator-demodulator) calibrated for 25.4 mm (1 in.) probe and 9 m (29 ft) electrical (system) length</p>	

Accessories

The following accessories are available.

Cat. No.	Description
EK-00331	Tacho signal conditioning unit
EK-15383	Linear variable differential transformer
EK-15629	Cam (valve) position detector rotary potentiometer
EK-44395	Hall effect speed sensor, magnetic, zero velocity
EK-44396	Connector cable for the hall effect speed sensor
EK-47026	2100 probe driver housing for four drivers (NEMA 4)
EK-47027	2100 probe driver housing for two drivers (NEMA 4)
EK-47028	2100 probe driver housing for six drivers (NEMA 4)

Tacho Signal Conditioning Unit

The tachometer signal conditioning unit (TSCU) converts a variety of tachometer signals to a TTL level square-wave output (0...5V typical). It is powered from a positive or negative power supply with a magnitude between 9...24V DC (20% tolerance).

The TSCU is designed to accommodate input signals with characteristics such as noisy signals, varying amplitudes, diverse or varying bias voltages, and the wide frequency-input range with no user configuration.

Attribute	TSCU
Supply voltage	Positive or negative, 7.2...28.8 V DC
Supply current	75 mA DC
Tachometer input, AC	0.75...70V AC peak-to-peak
Tachometer input, DC bias	-24...24V DC
Tachometer input, AC+DC	-35...35V
Input frequency	0.05 Hz...10 kHz (3 CPM...600 KCPM)
Pulse width, min	50 μ s
High level output	Vout = 2.7V DC min @ 4 mA
Low level output	Vout = 0.4V DC @ 1 mA
Temperature, operating	-30...65 °C (-22...49 °F)
Temperature, storage	-40...85 °C (-40...185 °F)
Relative humidity	95% relative, noncondensing

Linear Variable Differential Transformer

The linear variable differential transformer (LVDT) serves as the transducer element of a system that is used to measure the thermal expansion of a steam turbine shell (casing) relative to the turbine foundation. The LVDT is mechanically coupled to a rugged stainless-steel plunger assembly that contacts the turbine shell.

Attribute	LVDT
Range	0...50 mm (0...2 in.)
Linearity	±0.5% of Full Scale
Temperature range	-18...121 °C (0...250 °F)
Dimensions, overall, approx. (L x W x H)	400x102 x89 mm (15.75x4x3.5 in.)
Dimensions, housing with mounting feet, approx. (L x W x H)	273x102x89 mm (10.75x4x3.5 in.)
Enclosure	Drawn aluminum, NEMA-12

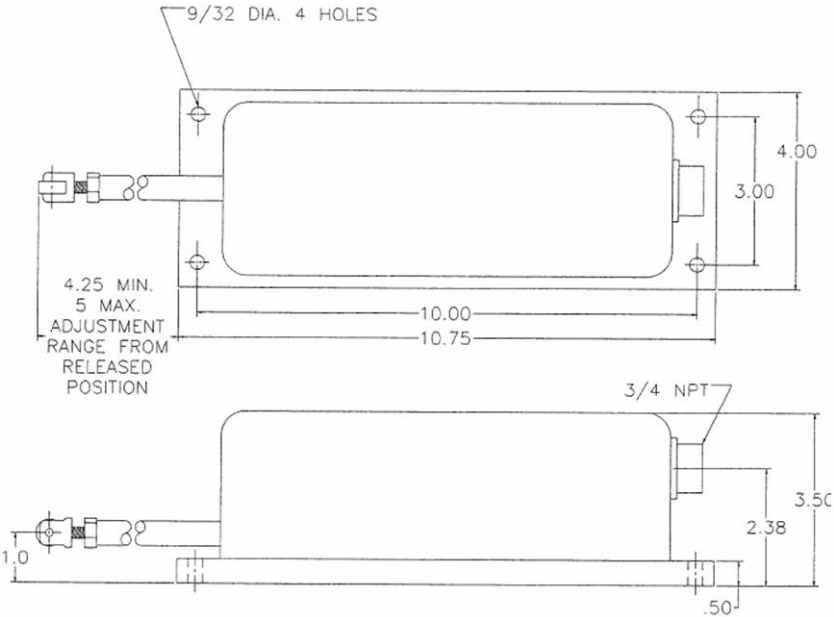

Rotary Potentiometer

The rotary potentiometer is used to provide accurate measures of governor valve, cams, and gear positions as part of a turbine-generator supervisory instrumentation system.

Catalog number EK-15629 is a direct replacement for GE catalog number 9888323 or equivalent cam position detectors.

The potentiometer operates over a full 360° mechanical (300° electrical) range. The arm of the detector will rotate in either direction and can be mounted at either end of the cam.

Attribute	Rotary Potentiometer
Input signals, max	3-wire, 0...28 V AC or DC, 0.42 A
Range	360° mechanical, 300° electrical
Dimensions, approx.	152 mm (6 in.) diameter body 9.5 mm (3/8 in.) diameter shaft 51 mm (2 in.) extension
Terminals	Screw
Resistance	1400 Ω
Installation	Replacement for GE 9888323 or equivalent, Two mounting holes on two 60.3 mm (3/8 in.) centers ¼-20 UNF thread
Weight, approx.	2.27 kg (5 lbs)
Construction	Ceramic body, wire-wound steel mounting bracket and aluminum shaft

Hall Effect Speed Sensor

Catalog number EK-44395 is an Airpax Model H1512-005 hall effect sensor designed to generate a steady pulse train in response to movement of a target surface.

Cat. No.	Description
EK-44395	Hall effect speed sensor, magnetic, zero velocity
EK-44396	Connector cable for the hall effect speed sensor

Attribute	Hall Effect Speed Sensor
Frequency range	Near 0...15 kHz
Power supply voltage	4.5...24V DC
Reverse voltage protection	Up to -30V DC
Temperature range	-40...125 °C (-40...257 °F)
TTL compatible logic	50% ±30% duty cycle
Housing material	300 series stainless steel
Target air gap	0.005...0.020 with 20 diametric pitch gear
	0.005...0.045 with 12 diametric pitch gear
	0.005...0.060 with 8 diametric pitch gear

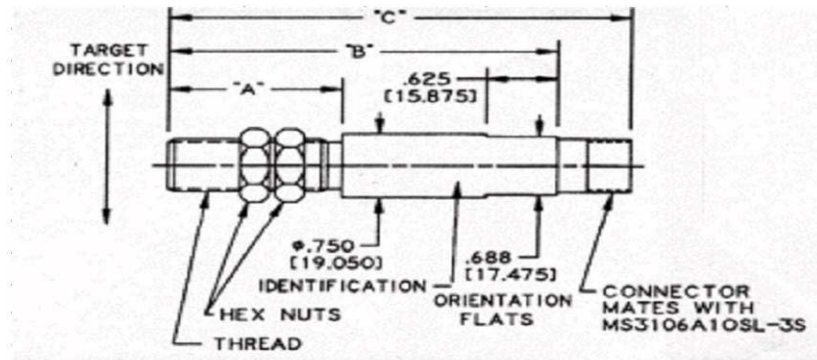

"A"	1.500" (38.100 mm)	"C"	4.012" (101.905 mm)
"B"	3.375" (85.725 mm)	Thread	5/8-18 UNF-2A

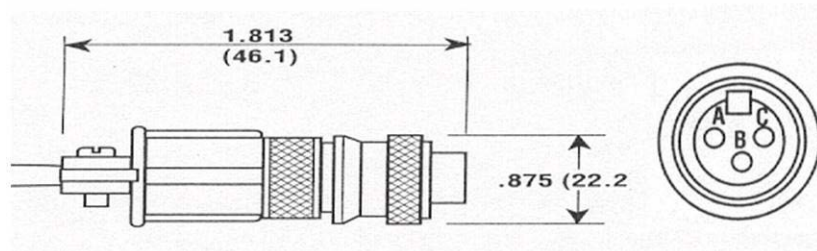

Connector P/N Ek-44396

MS3106A 10SK-3S

Wiring	
"A"	Vin
"B"	Vout
"C"	Common

2100 Probe Driver Housings

Panel mounted housings are available for the 2100 series probe drivers. These enclosures include an isolated mounting surface with predrilled holes designed specifically for the 2100 Series drivers.

Note that the 1442 series drivers do not require an isolated surface, as they are case isolated, and are suitable for mounting on common DIN rail within any standard enclosure.

Cat. No.	Description	Dimensions (HxWxD), Approx.
EK-47027	2100 probe driver housing for two drivers (NEMA 4)	292x203x102 mm (11.5x8.0x4.0 in.)
EK-47026	2100 probe driver housing for four drivers (NEMA 4)	
EK-47028	2100 probe driver housing for six drivers (NEMA 4)	394x305x152 mm (15.5 x 12.0 x 6.0 in.)

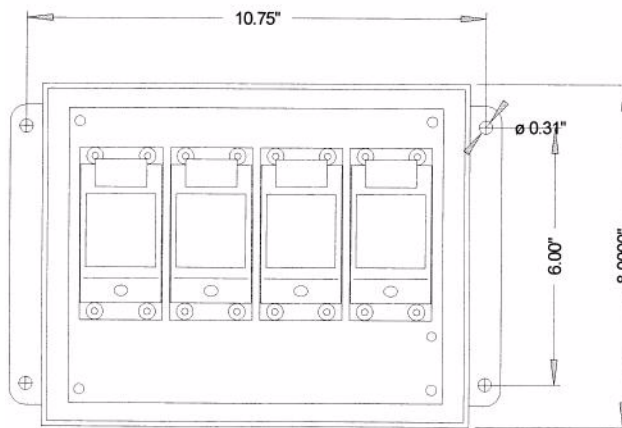
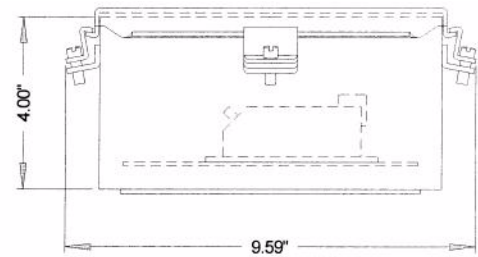
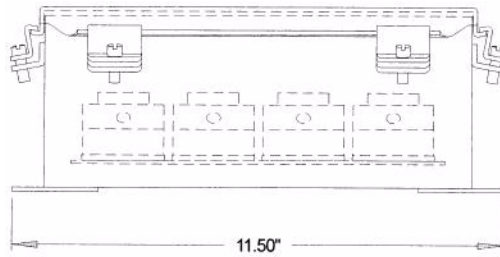

2100 Connector Sealing Kit

The connector sealing kit includes three 152.4 mm (6 in.) tubes that can be applied to improve the resistance to oil wicking.

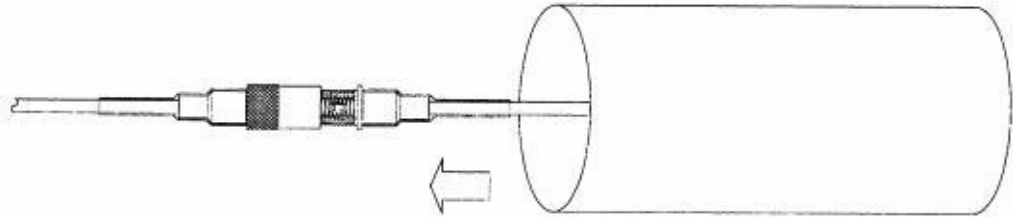

- Shrinks to 1/6 its original Size
- Heavy duty adhesive inner lining
- Low water absorption
- Excellent durability and toughness
- Resistant to oils and chemicals

Rockwell Automation Support

Rockwell Automation provides technical information on the Web to assist you in using its products. At <http://www.rockwellautomation.com/support/>, you can find technical manuals, a knowledge base of FAQs, technical and application notes, sample code and links to software service packs, and a MySupport feature that you can customize to make the best use of these tools.

For an additional level of technical phone support for installation, configuration, and troubleshooting, we offer TechConnect support programs. For more information, contact your local distributor or Rockwell Automation representative, or visit <http://www.rockwellautomation.com/support/>.

Installation Assistance

If you experience an anomaly within the first 24 hours of installation, review the information that is contained in this manual. You can contact Customer Support for initial help in getting your product up and running.

United States or Canada	1.440.646.3434
Outside United States or Canada	Use the Worldwide Locator at http://www.rockwellautomation.com/support/americas/phone_en.html , or contact your local Rockwell Automation representative.

New Product Satisfaction Return

Rockwell Automation tests all of its products to ensure that they are fully operational when shipped from the manufacturing facility. However, if your product is not functioning and needs to be returned, follow these procedures.

United States	Contact your distributor. You must provide a Customer Support case number (call the phone number above to obtain one) to your distributor to complete the return process.
Outside United States	Please contact your local Rockwell Automation representative for the return procedure.

Documentation Feedback

Your comments will help us serve your documentation needs better. If you have any suggestions on how to improve this document, complete this form, publication [RA-DU002](#), available at <http://www.rockwellautomation.com/literature/>.

www.rockwellautomation.com

Power, Control and Information Solutions Headquarters

Americas: Rockwell Automation, 1201 South Second Street, Milwaukee, WI 53204-2496 USA, Tel: (1) 414.382.2000, Fax: (1) 414.382.4444

Europe/Middle East/Africa: Rockwell Automation, Vorstlaan/Boulevard du Souverain 36, 1170 Brussels, Belgium, Tel: (32) 2 663 0600, Fax: (32) 2 663 0640

Asia Pacific: Rockwell Automation, Level 14, Core F, Cyberport 3, 100 Cyberport Road, Hong Kong, Tel: (852) 2887 4788, Fax: (852) 2508 1846

Rockwell Automation Publication ICM-TD005A-EN-P - January 2011

Supersedes 2100-TD030A-EN-P - October 2010

Copyright © 2011 Rockwell Automation, Inc. All rights reserved. Printed in the U.S.A.