



# AADvance Controller

Catalog Numbers T9110, T9300, T9310, T9401/2, T9431/2,  
T9451, T9481/2



**Allen-Bradley**

by ROCKWELL AUTOMATION

Solutions Handbook

Original Instructions

## Important User Information

Read this document and the documents listed in the additional resources section about installation, configuration, and operation of this equipment before you install, configure, operate, or maintain this product. Users are required to familiarize themselves with installation and wiring instructions in addition to requirements of all applicable codes, laws, and standards.

Activities including installation, adjustments, putting into service, use, assembly, disassembly, and maintenance are required to be carried out by suitably trained personnel in accordance with applicable code of practice.

If this equipment is used in a manner not specified by the manufacturer, the protection provided by the equipment may be impaired.

In no event will Rockwell Automation, Inc. be responsible or liable for indirect or consequential damages resulting from the use or application of this equipment.

The examples and diagrams in this manual are included solely for illustrative purposes. Because of the many variables and requirements associated with any particular installation, Rockwell Automation, Inc. cannot assume responsibility or liability for actual use based on the examples and diagrams.

No patent liability is assumed by Rockwell Automation, Inc. with respect to use of information, circuits, equipment, or software described in this manual.

Reproduction of the contents of this manual, in whole or in part, without written permission of Rockwell Automation, Inc., is prohibited.

Throughout this manual, when necessary, we use notes to make you aware of safety considerations.



**WARNING:** Identifies information about practices or circumstances that can cause an explosion in a hazardous environment, which may lead to personal injury or death, property damage, or economic loss.



**ATTENTION:** Identifies information about practices or circumstances that can lead to personal injury or death, property damage, or economic loss. Attentions help you identify a hazard, avoid a hazard, and recognize the consequence.

**IMPORTANT** Identifies information that is critical for successful application and understanding of the product.

Labels may also be on or inside the equipment to provide specific precautions.



**SHOCK HAZARD:** Labels may be on or inside the equipment, for example, a drive or motor, to alert people that dangerous voltage may be present.



**BURN HAZARD:** Labels may be on or inside the equipment, for example, a drive or motor, to alert people that surfaces may reach dangerous temperatures.



**ARC FLASH HAZARD:** Labels may be on or inside the equipment, for example, a motor control center, to alert people to potential Arc Flash. Arc Flash will cause severe injury or death. Wear proper Personal Protective Equipment (PPE). Follow ALL Regulatory requirements for safe work practices and for Personal Protective Equipment (PPE).

### About This Publication

This technical manual describes the features, performance and functionality of the AADvance controller and systems. It gives guidance on how to design a system to satisfy your application requirements.

In no event will Rockwell Automation be responsible or liable for indirect or consequential damages resulting from the use or application of this equipment. The examples given in this manual are included solely for illustrative purposes. Because of the many variables and requirements related to any particular installation, Rockwell Automation does not assume responsibility or reliability for actual use based on the examples and diagrams.

No patent liability is assumed by Rockwell Automation, with respect to use of information, circuits, equipment, or software described in this manual.

All trademarks are acknowledged.

### Disclaimer

It is not intended that the information in this publication covers every possible detail about the construction, operation, or maintenance of a control system installation. You should also refer to your own local (or supplied) system safety manual, installation and operator/maintenance manuals.

### Revision And Updating Policy

This document is based on information available at the time of its publication. The document contents are subject to change from time to time. The latest versions of the manuals are available at the Rockwell Automation Literature Library under "Product Information" information "Critical Process Control & Safety Systems".

### Downloads

The product compatibility and download center is [rok.auto/pcdc](http://rok.auto/pcdc).

Select the Find Downloads option under Download

In the Product Search field enter "AADvance" and the AADvance® option is displayed.

Double click on the AADvance option and the latest version is shown.

Select the latest version and download the latest version.

### AADvance Release

This technical manual applies to AADvance system release 1.40.

---

## Latest Product Information

For the latest information about this product review the Product Notifications and Technical Notes issued by technical support. Product Notifications and product support are available at the Rockwell Automation Support Center at [rok.auto/knowledgebase](http://rok.auto/knowledgebase).

At the Search Knowledgebase tab select the option "By Product" then scroll down and select the ICS Triplex® product AADvance.

Some of the Answer ID's in the Knowledge Base require a TechConnect<sup>SM</sup> Support Contract. For more information about TechConnect Support Contract Access Level and Features, click this link: Knowledgebase Document ID: [IP622 - TechConnect Support Contract - Access Level & Features](#).

This will get you to the login page where you must enter your login details.

---

**IMPORTANT** A login is required to access the link. If you do not have an account then you can create one using the "Sign Up" link at the top right of the web page.

---

## Purpose Of This Manual

The AADvance controller is a logic solver. It uses processor modules and I/O modules. An AADvance system is formed by one or more controllers, their power sources, communications networks and workstations.

This technical manual describes the features, performance and functionality of the AADvance controller and systems. It sets out some guidelines on how to make a system that fits your application requirements.

## Who Should Use This Manual

This manual is intended primarily for system designers and technical sales people who need to understand the capabilities of an AADvance controller. This manual will help you to design a satisfactory system.

The information contained in this manual is intended to be used in conjunction with (and not as an alternative for) expertise and knowledge about safety-related systems. It is expected that the reader has an in depth understanding of the intended application and can understand the generic terms used inside this manual and the terminology used in the integrator's or project's application area.

## Environmental Compliance

Rockwell Automation maintains current product environmental information on its website at [rok.auto/pec](http://rok.auto/pec).

## Download Firmware, AOP, EDS, and Other Files

Download firmware, associated files (such as AOP, EDS, and DTM), and access product release notes from the Product Compatibility and Download Center at [rok.auto/pcdc](http://rok.auto/pcdc).



## Summary of Changes

This publication contains the following new or updated information. This list includes substantive updates only and is not intended to reflect all changes.

### Global Changes

This table identifies changes that apply to all information about a subject in the manual and the reason for the change. For example, the addition of new supported hardware, a software design change, or additional reference material would result in changes to all of the topics that deal with that subject.

Subject	Reason
Applied latest publication template	Marketing product change

### New or Enhanced Features

This table contains a list of topics changed in this version and a link to the topic that contains the changed information.

Topic	Page
Added AADvance®-Trusted® SIS Workstation Software User Guide, publication <a href="#">ICSTT-UM002</a> to Additional Resources section.	<a href="#">5</a>
Updated AADvance system release version number in the AADvance Release section.	<a href="#">3</a>
Updated Vibration specification in Environmental Specification section.	<a href="#">19</a>
Added <b>mission time</b> definition in Glossary.	<a href="#">144</a>
Updated <b>proof test</b> definition in Glossary.	<a href="#">146</a>

## Additional Resources

These documents contain additional information concerning related products from Rockwell Automation.

Resource	Description
AADvance Controller Safety Manual, <a href="#">ICSTT-RM446</a>	This technical manual defines how to safely apply AADvance controllers for a Safety Instrumented Function. It sets out standards (which are mandatory) and makes recommendations to make sure that installations satisfy and maintain their required safety integrity level.
AADvance Controller System Build Manual, <a href="#">ICSTT-RM448</a>	This technical manual describes how to assemble a system, switch on and validate the operation of your system.
AADvance Controller Configuration Guide Workbench 1.x, <a href="#">ICSTT-RM405</a>	This software technical manual defines how to configure an AADvance controller using the AADvance Workbench software version 1.x to satisfy your system operation and application requirements.
AADvance Controller Configuration Guide Workbench 2.x, <a href="#">ICSTT-RM458</a>	This software technical manual defines how to configure an AADvance controller using the AADvance Workbench software version 2.x to satisfy your system operation and application requirements.
AADvance-Trusted SIS Workstation Software User Guide, <a href="#">ICSTT-UM002</a>	This publication provides how-to instructions for AADvance-Trusted SIS Workstation software configuration and use.
AADvance Controller OPC Portal Server User Manual, <a href="#">ICSTT-RM407</a>	This manual describes how to install, configure and use the OPC Server for an AADvance Controller.
AADvance Controller PFH and PFD <sub>avg</sub> Data, <a href="#">ICSTT-RM449</a>	This document contains the PFH and PFD <sub>avg</sub> Data for the AADvance Controller. It includes examples on how to calculate the final figures for different controller configurations.
AADvance Controller Solutions Handbook, <a href="#">ICSTT-RM447</a>	This technical manual describes the features, performance and functionality of the AADvance controller and systems. It gives guidance on how to design a system to satisfy your application requirements.
AADvance Controller Troubleshooting and Maintenance Manual, <a href="#">ICSTT-RM406</a>	This technical manual describes how to maintain, troubleshoot and repair an AADvance Controller.
Industrial Automation Wiring and Grounding Guidelines, publication <a href="#">1770-4.1</a>	Provides general guidelines for installing a Rockwell Automation industrial system.
Product Certifications website, <a href="http://rok.auto/certifications">rok.auto/certifications</a> .	Provides declarations of conformity, certificates, and other certification details.

You can view or download publications at [rok.auto/literature](http://rok.auto/literature).

---

**Notes:**

	<b>Preface</b> .....	3
	About This Publication .....	3
	Download Firmware, AOP, EDS, and Other Files .....	4
	Summary of Changes.....	5
	Additional Resources .....	5
	<b>Table of Contents</b> .....	7
	<b>Chapter 1</b>	
<b>The AADvance System</b>	Introduction.....	11
	<b>Chapter 2</b>	
<b>The AADvance Safety Controller</b>	Safety Features .....	15
	Safety Configurations .....	16
	Performance and Electrical Specifications.....	17
	Scan Times .....	17
	Environmental Specification .....	19
	Certifications for Safety System Applications in Hazardous Environments .....	19
	ATEX Certificate .....	19
	IECEX UL Certificate.....	20
	Module Label .....	20
	KCC-EMC Registration.....	20
	Main Components .....	20
	Physical Features .....	21
	Compact Module Design .....	21
	Module Polarization Keying .....	22
	Module Locking Mechanism.....	23
	Processor Base Unit.....	24
	External Ethernet, Serial Data and Power Connections.....	25
	Serial Communications Ports.....	25
	I/O Base Unit.....	26
	Termination Assemblies.....	27
	Product Dimensions .....	30
	Corrective Maintenance and Module Replacement.....	32
	Processor Back-up Battery.....	33
	Expansion Cable.....	35
	Technical Features .....	35
	TUV Approved Operating System .....	35
	Internal Diagnostics and Fault Reset .....	35
	Remote Fault Reset .....	36
	Controller Internal Bus Structure .....	37
	On-line updates I/O Configuration Changes .....	37
	Hot Swap I/O for Business Critical Channels.....	38
	Processor Firmware Upgrades .....	38
	Ethernet Communication Protocols .....	39

The AADvance Workbench and Software Development Environment	39
Operating Systems (32 or 64 bit)	41
Importing and Exporting Data	41
AADvance Workbench Licensing	42

## Controller Functionality

### Chapter 3

Field Data Handling	43
Process Safety Time	43
SNTP	43
CIP and its Producer and Consumer Variables	44
HART	45
Bindings and the SNCP Network	45
Serial Communication Interface	46
Time Synchronization SNTP	46
MODBUS Master	47
MODBUS Master Hardware and Physical Connections	47
Controller IP Address	48
Recovery Mode	49
Differential Services (DiffServ)	49
Serial Tunneling	49
Ethernet Forwarding	50
Compiler Verification Tool	51
The OPC Portal Server	51

## AADvance System Architectures

### Chapter 4

SIL 2 Architectures	53
SIL 2 Fail-safe Architecture	53
SIL 2 Fault Tolerant Input Architectures	54
SIL 2 Fault Tolerant Output Architecture	55
SIL 2 Fault Tolerant Input and SIL 2 High Demand Architecture	56
SIL 3 Architectures	57
SIL 3 Fail-safe I/O, Fault Tolerant Processor	57
SIL 3 Fault Tolerant I/O Architectures	58
SIL 3 TMR Input and Processor, Fault Tolerant Output	60
Certified Configurations	61
Example Architectures with Approved Modules	63
Standard Architectures	63
Simplex I/O Architecture	64
Dual Architecture for Fault Tolerant Applications	67
Triple Modular Redundant Architecture	69
Mixed Architectures	71
Mixed I/O Architectures	71
Mixed Safety Integrity Levels	72
Distributed Architectures	73
Example Distributed Controller Systems	74
Typical Network Applications	75
Controller External Network Connectors	76
Specifying a Safety Network	77



## AADvance Scalability

### Chapter 5

I/O Channel Capacity	79
Simplex I/O Channel Capacity	80
Dual I/O Channel Capacity	81
Triple Modular Redundant Channel Capacity	82
Adding I/O Channel Capacity	82
On-line updates I/O Configuration Changes	83
Bus Connectors and Expansion Cable	84
Redundancy and Fault Tolerance	85
Expansion using Distributed Controllers	85

## Specifying a New Controller

### Chapter 6

Information to Specify a New Controller	87
Define a New System	88
Specify I/O Base Units	91
Choosing Termination Assemblies	91
Estimate AADvance Controller Weight	92
System Installation Environment	92
Specifying an Enclosure	93
Maximum Enclosure Air temperature	93
Enclosure Requirements for a Non-hazardous Environment	93
Enclosure Requirements for a Hazardous Environment - Class I, Division 2, Groups A, B, C and D	94
Estimate Heat Dissipation	96
Backplane Electrical Ratings	96
System Power Requirements	97
Power Arrangements for Field Devices	98
Power Supply and Power Distribution Requirements	98
Estimating Power Consumption	99

## Module Overview and Specifications

### Chapter 7

T9110 Processor Module	101
T9110 Processor Module Specification	102
T9100 Processor Base Unit	102
T9100 Base Unit Specification	104
T9300 I/O Base Unit (3 way)	104
T9300 Base Unit Specification	106
T9310 Expansion Cable Assembly	106
T9310 Extension Cable Specification	107
T9401/2 Digital Input Module, 24 Vdc, 8/16 channel	107
T9401/2 Digital Input Module Specification	108
T9801/2/3 Termination Assemblies for Digital Inputs	109
T9801/2/3 Digital Input Termination Assembly	110
T9431/2 Analogue Input Module, 8/16 Channel	111
T9431/2 Analogue Input Module Specification	111
T9831/2/3 Termination Assemblies for Analogue Inputs	113
Analogue Input Termination Assembly	114
T9451 Digital Output Module, 24Vdc, 8 channel	115

	T9451 Digital Output Module Specification . . . . .	115
	T9851/2 Termination Assemblies for Digital Outputs . . . . .	116
	T9851/2 Digital Output Termination Assembly Specifications . . .	117
	T9892 Digital Output Termination Assembly . . . . .	117
	T9481/2 Analogue Output Module. . . . .	118
	T9481/2 Analogue Output Module Specification. . . . .	119
	T9881/2 Termination Assemblies for Analogue Outputs . . . . .	119
	T9881/2 Analogue Output Termination Assembly Specification .	120
	 <b>Chapter 8</b>	
<b>Application (Resource) Development</b>	Programming Language Support. . . . .	121
	Program Management Facilities. . . . .	121
	Support for Variable Types. . . . .	121
	I/O Connection (Addressing of Physical I/O). . . . .	122
	Off-line Simulation and Testing . . . . .	122
	Application (Resource) Program Security. . . . .	122
	Aids to Software Development . . . . .	123
	 <b>Chapter 9</b>	
<b>System Build</b>	Controller Mounting . . . . .	125
	Free Space around the Controller . . . . .	125
	Assemblies of Base Units. . . . .	128
	Base Units Rows and Expansion Cables . . . . .	128
	Controller Power Supply Requirements . . . . .	130
	Adding Field Cable Management . . . . .	131
	 <b>Chapter 10</b>	
<b>Parts List</b>	Base Units. . . . .	133
	Modules. . . . .	133
	Special Application Modules . . . . .	133
	Termination Assemblies . . . . .	133
	Expansion Cable Assembly. . . . .	134
	Blanking Covers . . . . .	134
	Spares and Tools. . . . .	134
	Software . . . . .	134
	Demonstration Unit. . . . .	135
	Miscellaneous Items. . . . .	135
	 <b>Appendix A</b>	
<b>History of Changes</b>	. . . . .	137
	 <b>Glossary</b> . . . . .	139

## The AADvance System

### Introduction

An AADvance® system consists of an AADvance controller, an external operator's workstation, field connections, power sources and external network connections. The flexibility of the design means that a system can meet a wide variety of business needs. An AADvance system is assembled to a scale and configuration that is applicable to your initial requirements and can be easily changed to meet your changing business requirements in the future. A system is built from an approved range of modules and assemblies.

This chapter introduces the primary components that can be used to assemble an AADvance controller.

**Notes:**



## The AADvance Safety Controller

The AADvance® controller is specifically designed for functional safety and critical control applications; it gives a flexible solution for smaller scale requirements. The system can also be used for safety implemented functions as well as applications that are not related to safety but are nevertheless critical to a business process. This AADvance controller offers the ability to make a cost-effective system to a customer's specification for any of the following applications:

- Emergency shutdown system
- Fire and gas installation protection system
- Critical process control
- Burner management
- Boiler and furnace control
- Distributed process monitoring and control
- Turbo-machinery governor control and over-speed protection (not yet released)

An AADvance controller is particularly useful for emergency shut down and fire and gas detection protection applications as it offers a system solution with integrated and distributed fault tolerance. It is designed and validated to international standards and is certified by independent certifying bodies for functional safety control installations and UL for use in hazardous environments.

A controller is built from a range of compact plug-in modules (see illustration) that are straightforward to assemble into a system. A system can have just one or more controllers, a combination of I/O modules, power sources, communications networks and user workstations. It can operate as a stand-alone system or as a distributed node of a larger control system.

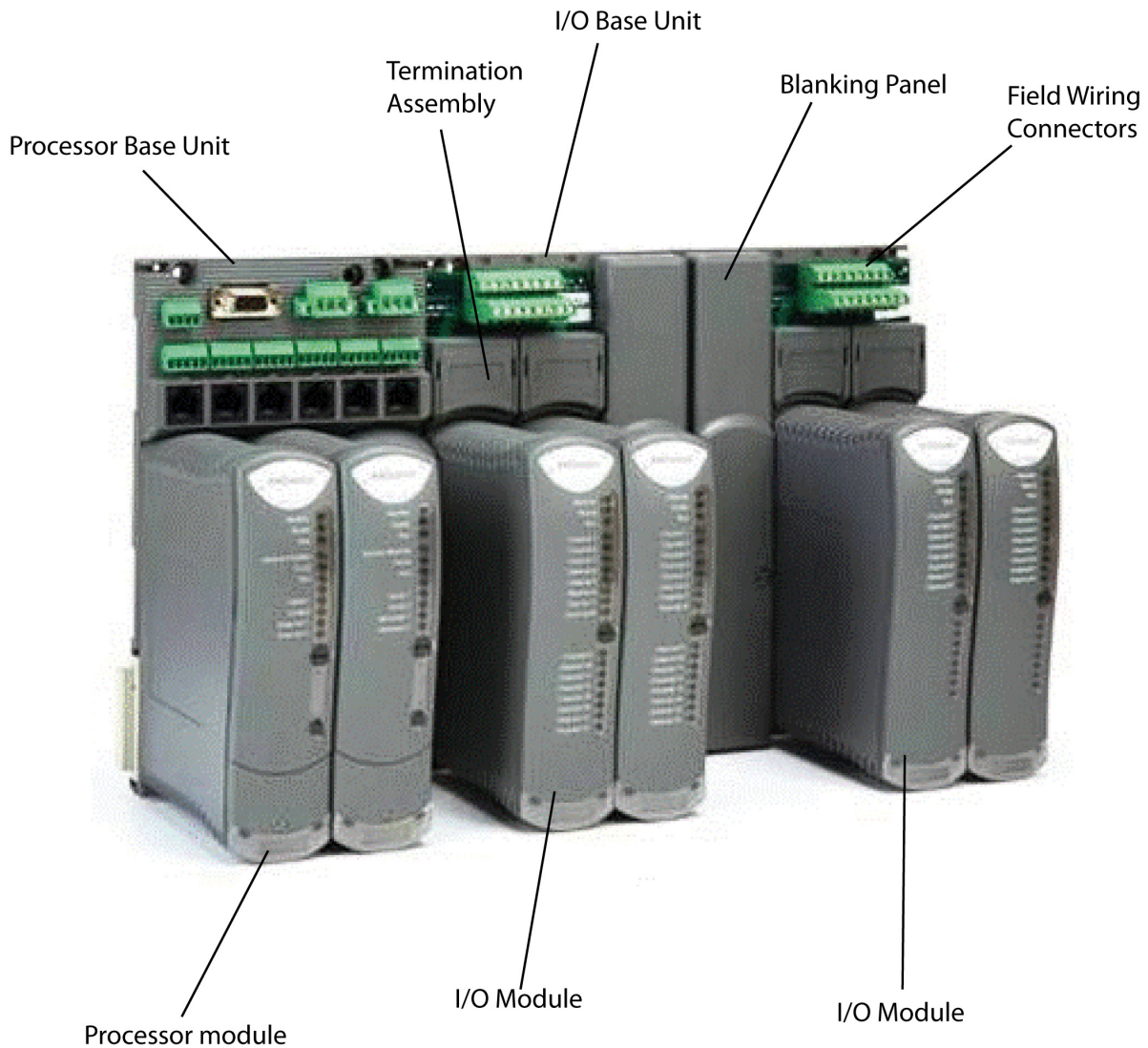

---

**NOTE** The printed circuit boards of all AADvance modules, termination assemblies and backplanes are coated during manufacture. The coating meets defense and aerospace requirements, is approved to US MIL-1-46058C standard and meets IPC-CC-830. The coating is also UL approved.

---

A Key benefit of the AADvance system is its flexibility. All of the configurations are readily achieved by combining modules and assemblies without using special cables or interface units. System architectures are user configurable and can be changed without major system modifications.

I/O redundancy is configurable so you can make a decision between fail safe and fault tolerant solutions. There is no change to the complexity of operations or programming that the controller can handle if you add redundant capacity to create a fault tolerant solution.

They can be mounted onto DIN rails in a cabinet or directly mounted onto a wall in a control room. Forced air cooling or special environmental control equipment is not necessary. However, important consideration must be given

to the choice of cabinet or when the controller is installed in a hazardous environment.

Specific guidelines are given in this user documentation to help you choose an enclosure that will make sure that the system operates to its full capability and reliability and that it also complies with the ATEX and UL certification requirements for use in hazardous environments.

The Ethernet and serial ports are configurable for a number of protocols in both simplex and redundant configurations for connection to other AADvance controllers or external third party equipment. Communications internally between the processors and I/O modules uses a proprietary communications protocol over a custom wired harness. The AADvance system supports transport layer communication protocols such as TCP and UDP for MODBUS, CIP, IXL, Telnet and SNTIP services.

A secure network communications protocol (SNCP), developed by Rockwell Automation for the AADvance system, permits distributed control and safety using new or existing network infrastructure while ensuring the security and integrity of the data. Individual sensors and actuators can connect to a local controller, minimizing the lengths of dedicated field cabling. There is no need for a large central equipment room; rather, the complete distributed system can be administered from one or more PC workstations placed at convenient locations.

The AADvance controller is developed and built for IEC 61131 compliance and includes support for all five programming languages. (Instruction List (IL) and Sequential Function Chart (SFC) languages are not supported by AADvance® Workbench 2.0). Program access is secured by a "Program Enable" key that you can remove. Simulation software lets you prove a new application before reprogramming and downloading, again maximizing system uptime. Additional security functions are also included to help prevent unauthorized access.

## Safety Features

The AADvance controller meets non-safety business requirements and SIL 2 and SIL 3 safety related system requirements. The system has comprehensive built-in redundant capabilities that improve system availability.

The AADvance safety system features are:

- Easily transformed from a simplex non-safety system to a fault tolerant safety related system.
- An AADvance platform provides a set of components that can be configured to meet a range of safety and fault tolerance user requirements within a single system such as - fault tolerant topologies 1001, 1002D and 2003.
- IEC 61508 certified, reviewed and approved for safety systems up to SIL 3 by independent certifying bodies.
- The scalable characteristics of the system enables independent safety functions within the same system to be configured with different architectures to meet a user specific safety and availability requirements.
- The main components that provide the safety architecture are the processor and I/O modules; the remaining components provide secure

external interfaces and connectivity between the field elements and the main components and add to the safety functionality.

- AADvance processor modules are designed to meet the requirements for SIL 2 and SIL 3 in a dual or triplicated configuration.
- Individual input modules are designed to meet the requirements for SIL 3 in simplex, dual or triple configurations.
- Individual output modules have been designed to meet the requirements for SIL 3 in a simplex or dual configurations.
- Safe SIL 3 rated 'Black Channel' external communication over Ethernet.

## Safety Configurations

An AADvance system supports the following safety configurations:

### Fail-safe

I/O modules fail-safe in the most basic simplex system.

### SIL 2

SIL 2 architectures for fail-safe low demand applications. All SIL 2 architectures can be used for energize or de-energize to trip applications.

- SIL 2 low demand architectures
- SIL 2 fail safe architectures
- SIL 2 fault tolerant input architectures
- SIL 2 triplicated input architectures
- SIL 2 fault tolerant output architectures
- SIL 2 fault tolerant input/output architectures

### SIL 3

SIL 3 architectures:

- SIL 3 de-energize to trip applications.
- SIL 3 energize to action applications when fitted with dual digital output modules.
- SIL 3 simplex or dual output module architectures
- SIL 3 fail safe I/O fault tolerant processor architecture
- SIL 3 fault tolerant architecture
- SIL 3 fault tolerant simplex, dual and triple input architectures
- SIL 3 dual or triple processor architectures
- SIL 3 high demand applications where the required safe state is greater than 4 mA, when fitted with dual analogue output modules (A 'safe state' is an output configured to go to a specific value, or configured to hold last state)



## Performance and Electrical Specifications

**Table 1 - Controller Performance and Electrical Specifications**

Attribute	Value
<b>Performance Characteristics</b>	
Safety Integrity Level	IEC 61508 SIL 2 IEC 61508 SIL 3 (depending on processor and I/O module configuration)
Safety level Degradation	1oo1D, 1oo2D, 2oo3D <sup>(1)</sup>
Processor Modules supported	Three
I/O Modules supported	48 (8 or 16 channels modules)
Safety Accuracy Limit: Digital inputs Analogue inputs	1.0 Vdc 200 µA
Sequence of Event Resolution Processor Module (for internal Variables): Event Resolution Time Stamp Accuracy Digital Input Module: Event Resolution Time Stamp Accuracy	1 ms Application Scan  1 ms 10 ms
<b>Electrical Characteristics</b>	
Supply voltage	Redundant 24 Vdc nominal, 18 Vdc to 32 Vdc range
Channel isolation (channel to channel and channel to chassis) Maximum withstanding	± 1.5 kVdc withstand for 1 minute.

(1) When a controller's processor modules have degraded to 1oo1D, the system must be restored to at least 1oo2D by replacing the faulty processor module(s) within the MTTR assumed in the PFD calculations; also, unless compensating measures are defined in the Safety Requirements Specification (SRS) and documented in operating procedures, the application program must be designed to shut down safety instrumented functions if a module failure due to dangerous fault has not been replaced within the MTTR.

**IMPORTANT** Overall system power consumption, heat dissipation and weight can be estimated using the values given in the heat dissipation and weight data tables shown in this manual.

### Scan Times

The controller processing scan times listed in the table are taken from a test system which used only production modules. The tests which were used to measure the scan times did not measure the effects of logic complexity and communications loading.

**Table 2 - Typical Module Scan Times**

Module	Scan
9402	Digital input module, 24 Vdc, 16 channel Simplex Dual Triple 0.924 ms 1.676 ms 2.453 ms
9432	Analogue input module 24 Vdc, 16 channel Simplex Dual Triple 1.170 ms 1.965 ms 2.656 ms
9451	Digital output module, 24 Vdc, 8 channel Simplex Dual 1.174 ms 2.202 ms

**Table 2 - Typical Module Scan Times**

Module		Scan
9482	Analogue output module, 24 Vdc, 8 channel	0.981 ms
	Simplex Dual	1.761 ms
	Minimum cycle time overhead <sup>(1)</sup>	39.3 ms
	Scan overhead for each module	0.04 ms

(1) The minimum overhead to the cycle time is a feature of the AADvance Workbench.

The scan time is:

Scan time = 39.3 ms

+ Sync time

+ Total number of modules \* 0.04 ms

+ Σ (Number of module groups x scan time shown above)

Where:

Sync time is a function of the total number of modules defined according to the following table:

0..10 modules	20 ms
11..20 modules	22 ms
21..30 modules	24 ms
31..40 modules	27 ms
41..48 modules	32 ms.

Though the average scan time will be within 1 ms of the scan time calculated above the calculation does not take into account the effects of application logic and network communication, and individual scans can vary by up to +/- 4 ms around the average scan time.

Throughput time is the time from input change to output action. For asynchronous inputs the throughput times can be derived from the Scan time calculated above according to the following formulae:

- Minimum throughput time = Scan period + 7 ms
- Maximum throughput time = 2 x Scan time + 13 ms

**EXAMPLE: An example configuration scan time:**

System configuration includes T9432 analogue input simplex modules x 30 and T9451 Digital output simplex modules x 18.

Total I/O modules = 48

Sync time = 32 ms

Scan time = 39.3 ms + 32 ms + (48 x 0.04) ms + (30 x 1.170) ms + (18 x 1.174) ms => 129.5 ms

Minimum throughput time = 129.5 ms + 7 ms => 136.5 ms

Maximum throughput time = (2 x 129.5) ms + 13 ms = 272.0 ms.

## Environmental Specification

An AADvance system can be installed in a non-hazardous or a hazardous environment. In a non-hazardous environment a system does not have to be installed in an enclosure; however, the area where it is installed must maintain a Pollution Degree 2 environment (IEC 60664-1).

The following environmental specification defines the minimum environmental conditions for an AADvance controller installation. Additional conditions apply to systems installed in a Hazardous environment.

**Table 3 - Environmental Specification**

Attributes	Value
Operating Temperature Range: For use in Hazardous Environments: Processor Modules I/O Modules and Termination Assemblies For use in Non-hazardous Environments: Processor Modules, I/O modules and Termination Assemblies	-25 °C to +60 °C (-13 °F to +140 °F) -25 °C to +70 °C (-13 °F to +158 °F) -25 °C to +70 °C (-13 °F to +158 °F)
Storage and Transport Temperature Range	-40 °C to +70 °C (-40 °F to +158 °F)
Module Surface Temperature (during usual operation)	43° C (109 °F) ± 2 °C
Humidity	
Operating	10 % to 95 % RH, non-condensing
Storage and Transport	10 % to 95 % RH, non-condensing
Vibration	
Frequency Range 5-8.4Hz	3.5 mm Continuous Displacement
Frequency Range 8.4-150Hz	1 g Continuous Acceleration
Endurance Sweeps	10
Endurance Sweep Rate	1 octave/Min.
ShockI	
Acceleration, Operating	15 g / 11 ms duration
Applications	3 ± shocks per axis (18 total)
Altitude	
Operating	0 to 2,000 m (0 to 6,600 ft.)
Storage and Transport	0 to 3,000 m (0 to 10,000 ft.) This equipment must not be transported in unpressurized aircraft flown above 10,000 ft.
Electromagnetic Interference	Tested to the following standards: EN 61326-1:2006, Class A; EN 61326-3-1:2008, EN 54-4: 1997, A1; EN 61131-2:2007; EN 62061:2005.
Hazardous Location Capability	Suitable for Class I Div 2 Groups A, B, C and D



There is no specific protection against liquids.

## Certifications for Safety System Applications in Hazardous Environments

### ATEX Certificate

Refer to AADvance Series T9000 Programmable Control and Safety System - ATEX certificate, publication [9000-CT003](#).

## IECEX UL Certificate

Refer to AADvance Series T9000 Programmable Control and Safety System - IECEX certificate, publication [9000-CT006](#).

## Module Label

The following label information must be attached to each module.

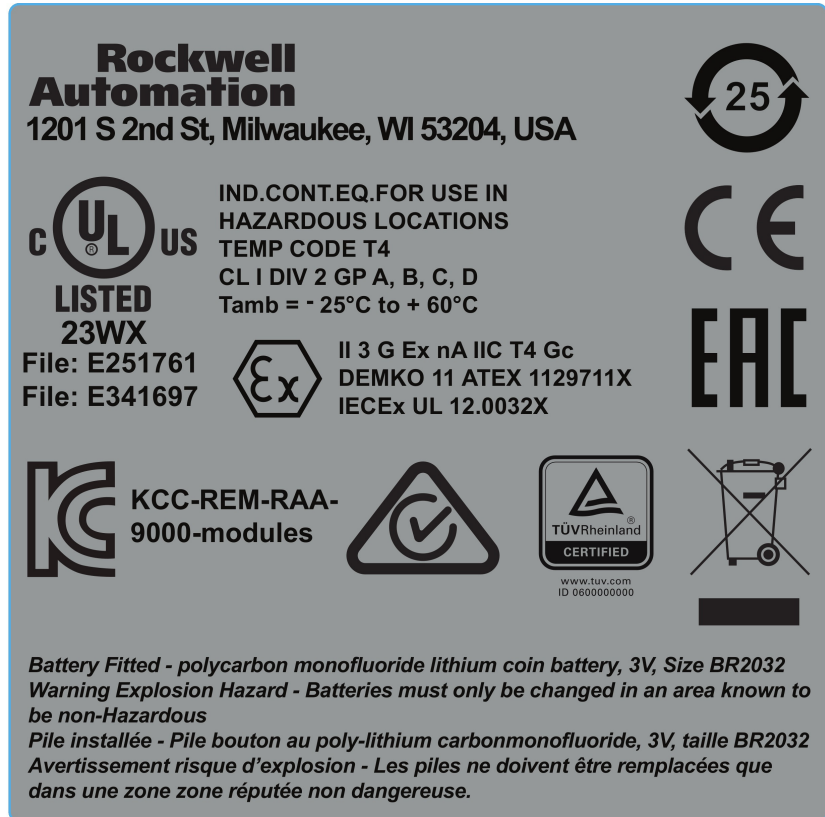

## KCC-EMC Registration

1. A급 기기 (업무용 방송통신기기): 이 기기는 업무용(A급)으로 전자파적합등록을 한 기기이오니 판매자 또는 사용자는 이 점을 주의하시기 바라며, 가정외의 지역에서 사용하는 것을 목적으로 합니다.
  - Translation: Class A device (Broadcasting Communication Device for Office Use): This device obtained EMC registration for office use (Class A), and may be used in places other than home. Sellers and/or users need to take note of this.

## Main Components

An AADvance controller is built from durable processor and I/O modules and assemblies designed to IEC 61508 standards for safety systems and runs the AADvance Workstation software. Field devices connect direct to a controller and external communication links over Ethernet and serial links use a secure protocol.



# Physical Features

A new and innovative style characteristic of the AADvance controller is the design of the hardware. All the modules and assemblies connect together easily without the need for inter-module wiring.



**CAUTION:** The controller contains static sensitive components. When the controller is installed attach a label that is clearly visible to tell operators to follow anti-static precautions when they touch or move modules. Failure to follow these instructions can result in damage to the equipment.

## Compact Module Design

Each processor and I/O module has a flame-retardant and impact-resistant plastic cover. The cover is designed to help ventilation and heat dissipation occur naturally without the need for fan assisted cooling. Processor and I/O modules fit onto standardized base units. Base units plug together by side connectors and are securely held in position by specially designed plastic clips which cannot corrode or seize up. Modules are retained by a locking screw which is easy to access from the front.

Figure 1 - An AADvance Module



**NOTE** Standard AADvance modules have a plastic casing and are rated IP20: Protected against solid objects over 12 mm (1/2 in.) for example "fingers". There is no specific protection against liquids.

### Module Polarization Keying

For each I/O Module there is a matched termination assembly. The controller incorporates module polarization keying to make sure that they are correctly mated when installed. Sockets on the rear end plate align and mate with coding pins found on the termination assembly. The alignment of the sockets and pins make sure that only the matched I/O modules and termination assemblies can be mated.

Figure 2 - Coding Sockets

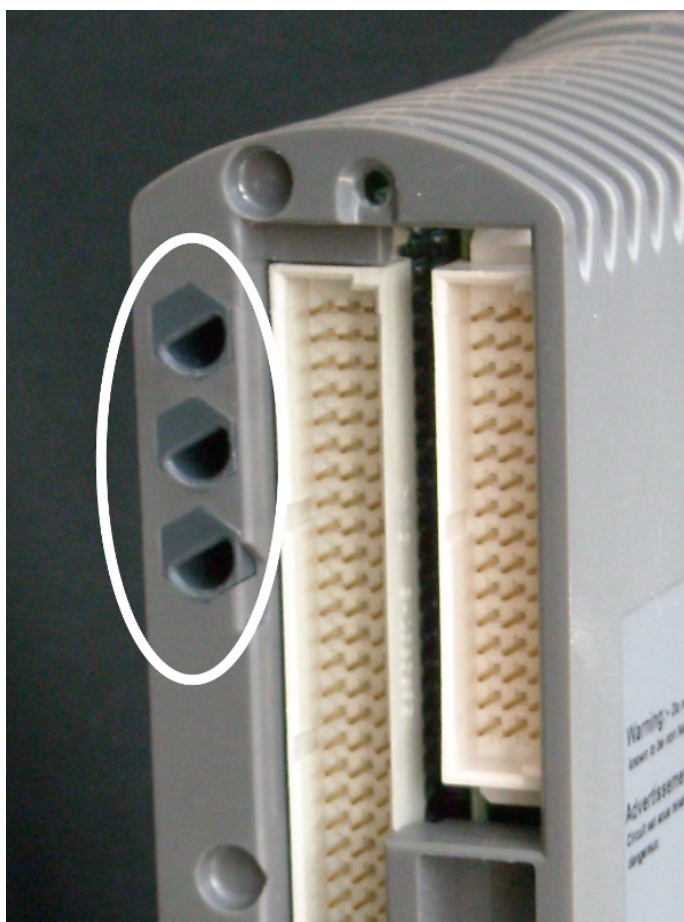

## Module Locking Mechanism

Figure 3 - Locking Screw



Each module carries a locking mechanism, which secures the module onto its base unit. The locking mechanism is in the form of a clamp screw, which can be seen on the front panel of the module and engaged by a quarter turn of a flat blade screwdriver. The module senses the locking mechanism position and notifies the controller accordingly. This acts as an interlock device and helps prevent the module from going on-line when it is not in the locked position.

## Processor Base Unit

A processor base unit holds up to three processor modules:

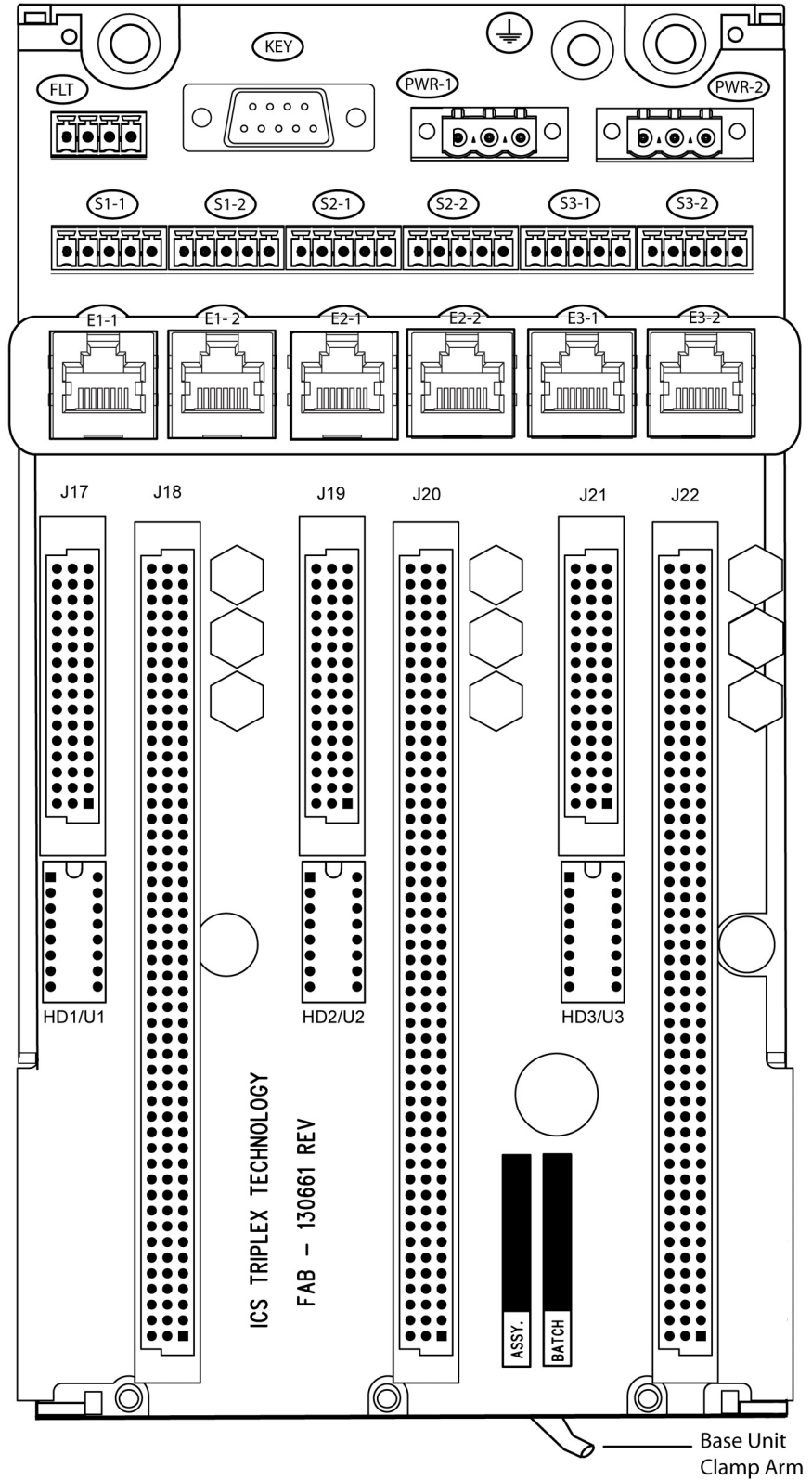

## External Ethernet, Serial Data and Power Connections

The processor base unit external connections are:

- Earthing Stud
- Ethernet Ports (E1-1 to E3-2)
- Serial Ports (S1-1 to S3-2)
- Redundant +24 Vdc powers supply (PWR-1 and PWR-2)
- Program Enable security key (KEY)
- The FLT connector (currently not used).

Figure 4 - External Connectors on the Processor Base Unit

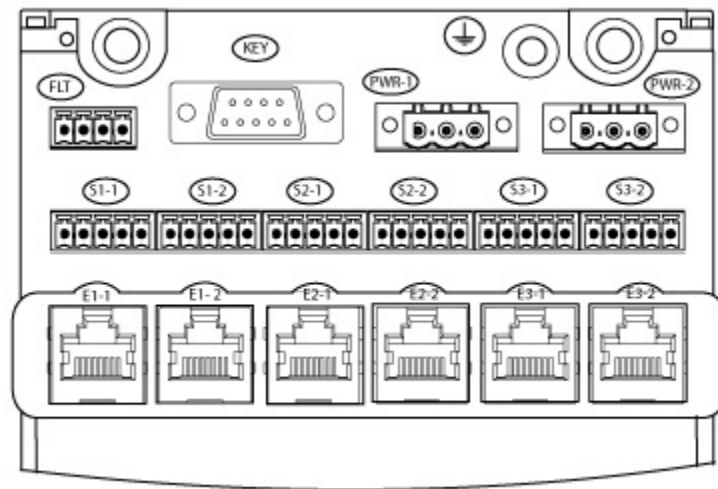

The power connections supply all three modules with redundant power, each processor module each have two Serial ports and two Ethernet port connectors. The KEY connector supports all three processor modules and helps prevent access to the application unless the Program Enable key is inserted.

### Serial Communications Ports

The serial ports (S1-1 and S1-2; S2-1 and S2-2; S3-1 and S3-2) support the following signal modes depending on use:

- RS485fd: A four-wire full duplex connection that features different busses for transmit and receive. This selection must also be used when the controller is acting as a MODBUS master using the optional four-wire definition specified in Section 3.3.3 of the MODBUS-over-serial standard.
- RS485fdmux: A four-wire full-duplex connection with tri-state outputs on the transmit connections. This must be used when the controller is acting as a MODBUS Slave on a four-wire bus.
- RS485hdmux: A two-wire half duplex connection applicable for master slave or slave use. This is shown in the MODBUS-over-serial standard.

## I/O Base Unit

An I/O base unit holds up to three I/O modules:

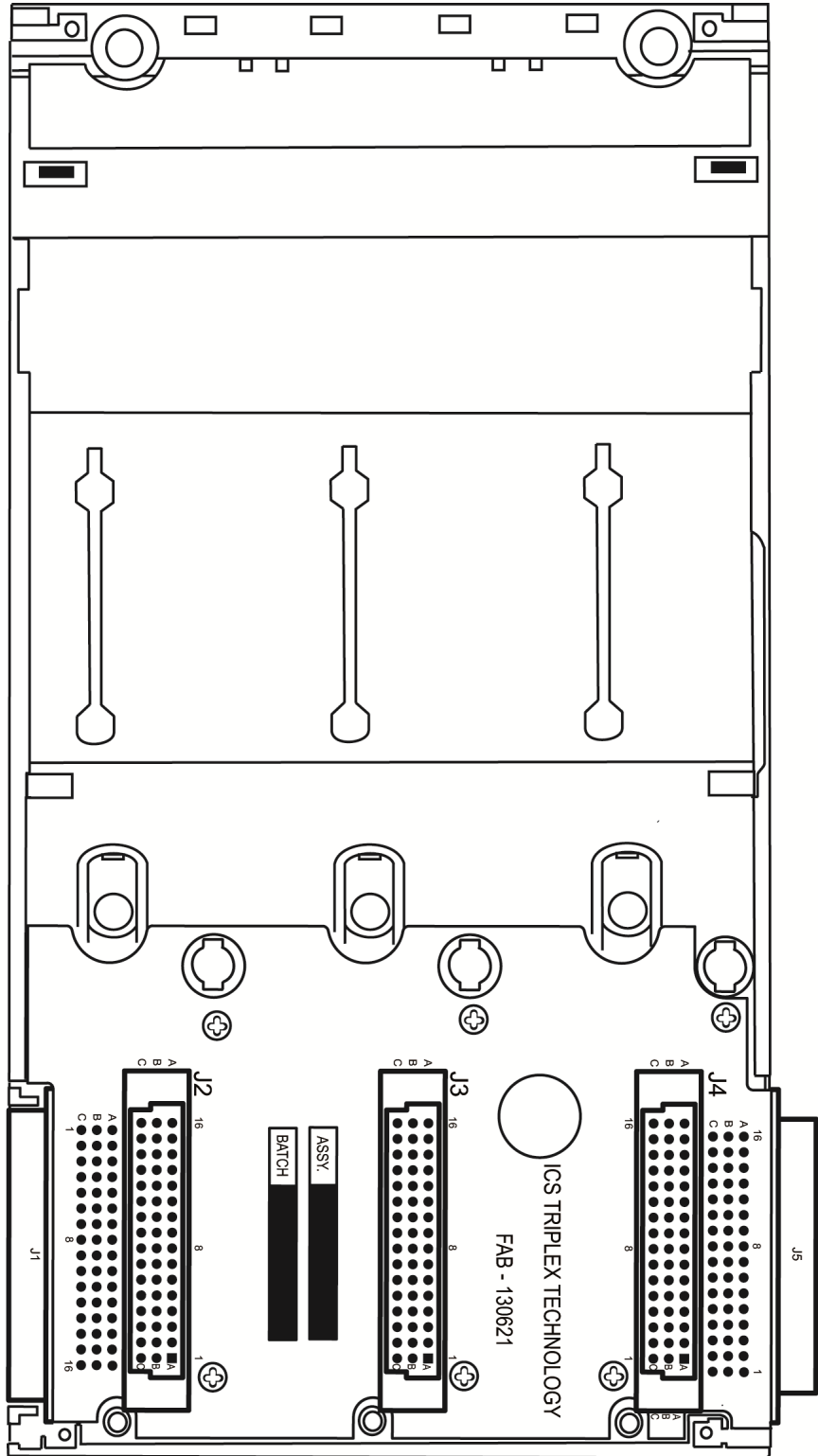



## Termination Assemblies

The AADvance system provides a range of termination assemblies to connect field wiring to the I/O modules. A termination assembly is a printed circuit equipped with screw terminal blocks for the field wiring (and in some cases fuses) and connectors for the plug-in I/O modules. Termination assemblies give the system designer flexibility when configuring redundant and fault tolerant systems.

Termination assemblies come in three types: simplex, dual or triple to accommodate one two or three I/O modules. Each termination assembly provides connections for up to 16 channels but can accommodate 8 or 16 channel modules.

The version illustrated is a simplex termination assembly for a digital input module. The field wiring connectors are located to the left, the fuses have a cover (shown open) and the module sockets are to the right. Each fuse cover has a label that identifies the fuse numbers.

**Figure 5 - Single Termination Assembly**

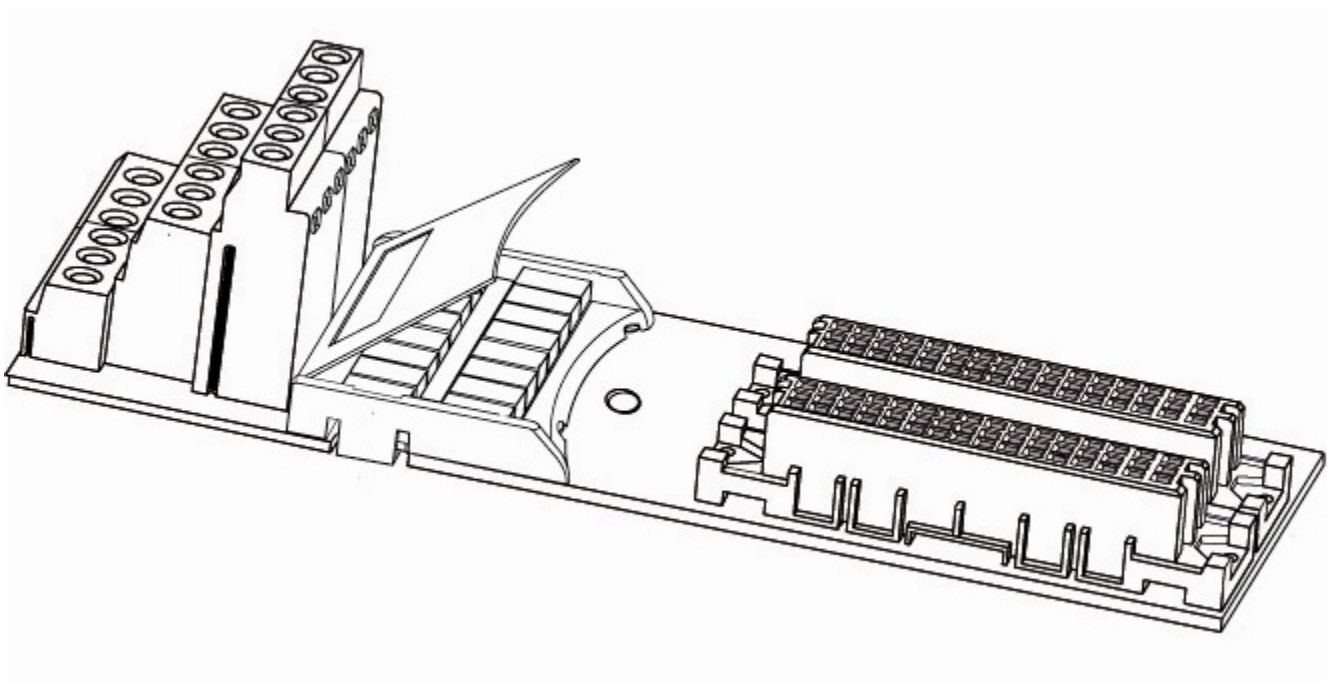
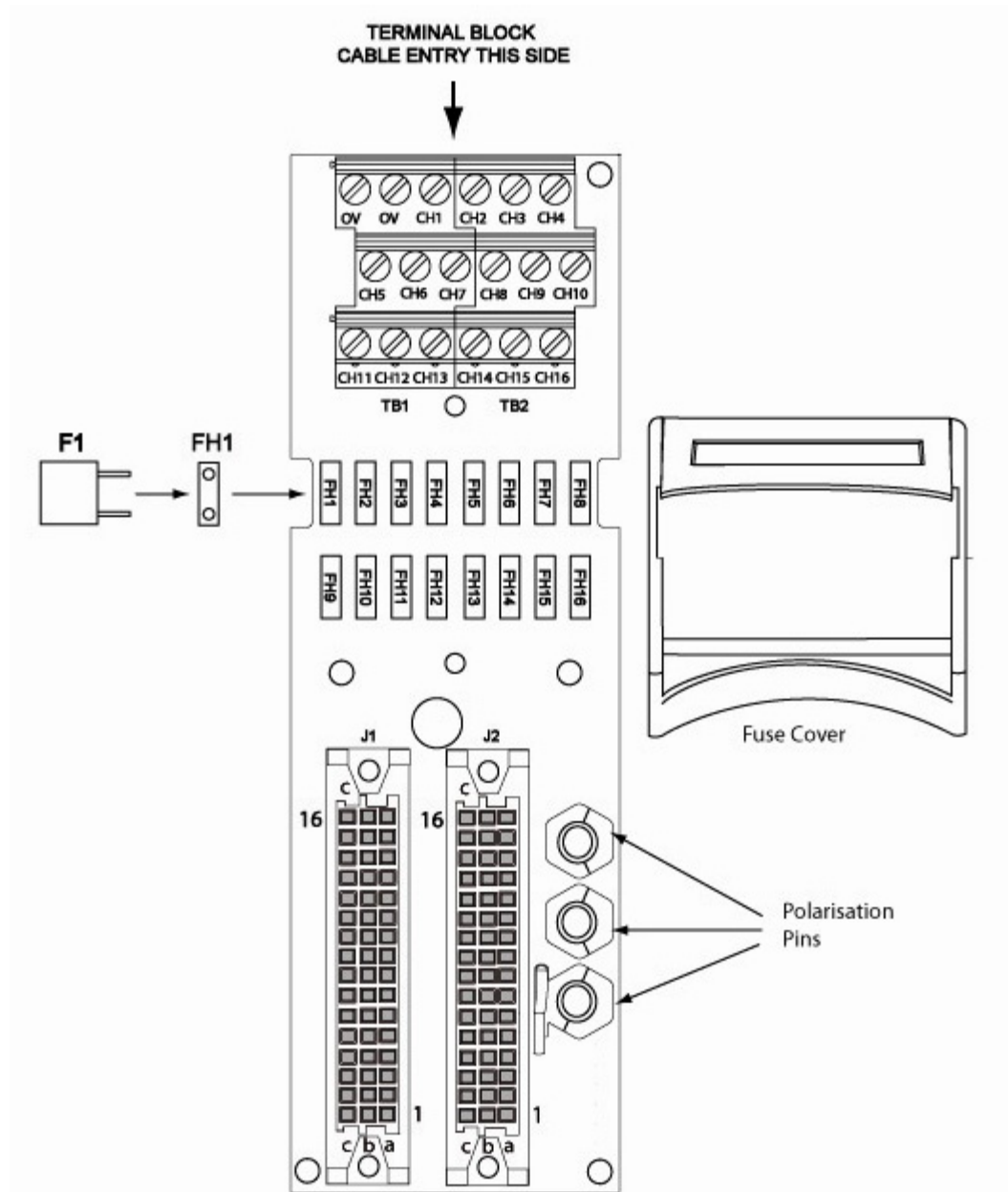



Figure 6 - Top View



*T9892 Digital Output Termination Assembly*

The T9892 Terminal Assembly module operates in conjunction with the T9451 Digital Output Module and provides 8 dual configuration output channels. It shares the same pin-out as the standard AADvance T9852 Digital Output Terminal Assembly and has the same coding peg configuration. The difference is that the T9892 has a separate connector for the field power input voltage connections (the left most terminal block shown below). It also has additional fusing to give extra protection against field faults.

Figure 7 - T9892 Dual Termination Assembly

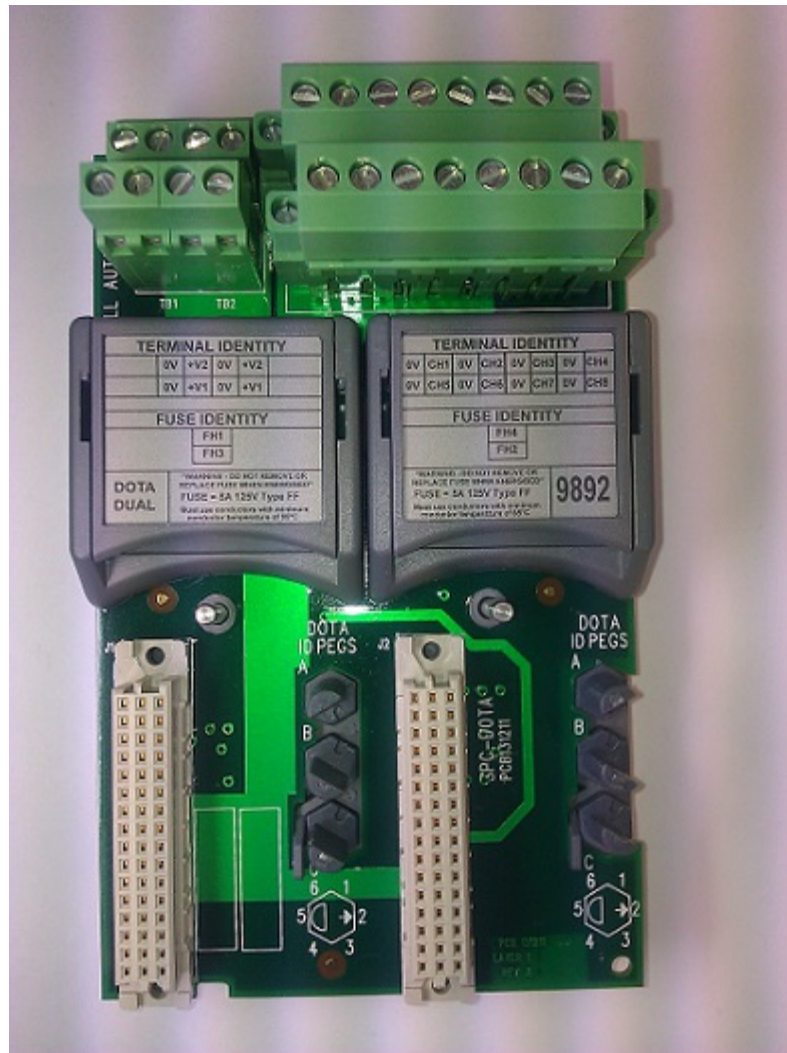

### *Field Wiring*

Field device wiring connections are made to industry-standard screw terminal blocks on the termination assemblies. Terminals are easy to access without needing to dismantle assemblies. The specification for the field wiring sizes is given in the topic "Power and External Connector Wiring Requirements".

This illustration shows field wiring connections at the termination assemblies.

Figure 8 - Field Wiring Connections



---

**NOTE** The recommended torque for termination assembly screw connectors is 5 Nm.

---

### Product Dimensions

A typical controller arrangement is shown with processor modules installed on the processor base unit and an I/O base unit mated with the processor base unit. I/O modules are installed on the base unit and a termination assembly plugged into the I/O base unit.

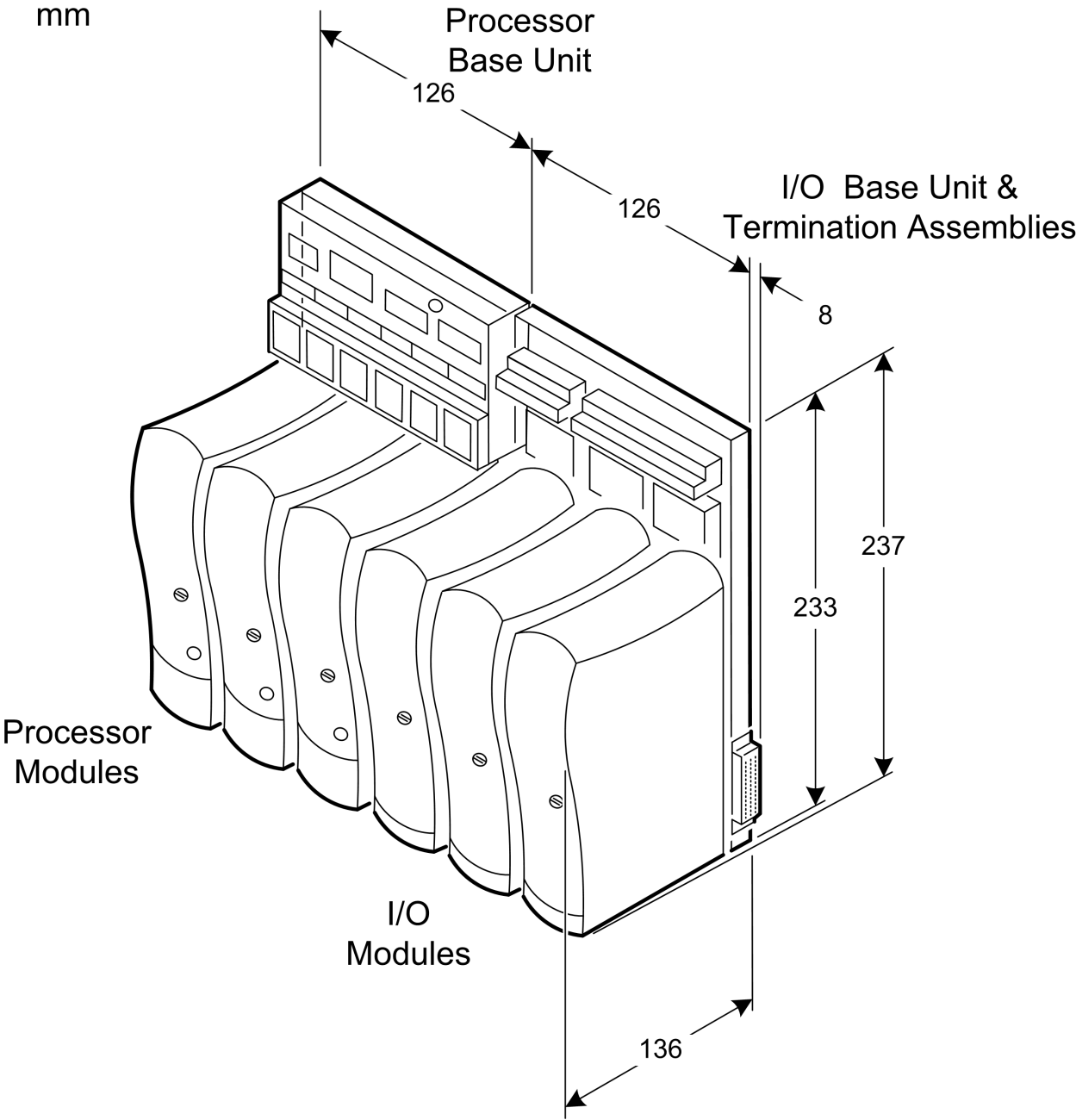

**Table 4 - Summary of Dimensions**

Attribute	Value
Base unit dimensions (H × W × D), approx.	233 mm × 126 mm × 18 mm (see text) (9-¼ in. × 5 in. × ¾ in.)
Module dimensions (H × W × D), approx.	166 mm × 42 mm × 118 mm (6-½ in. × 1-¾ in. × 4-¾ in.)

The depth of the base unit (18 mm) excludes the parts of the backplane connectors that mate inside the module connectors. Adding the depth of a module (118 mm) to the depth of the base unit gives the overall depth of the controller assembly at 136 mm.

### Module Dimensions

All modules have the same dimensions.

**Figure 9 - Module Dimensions**

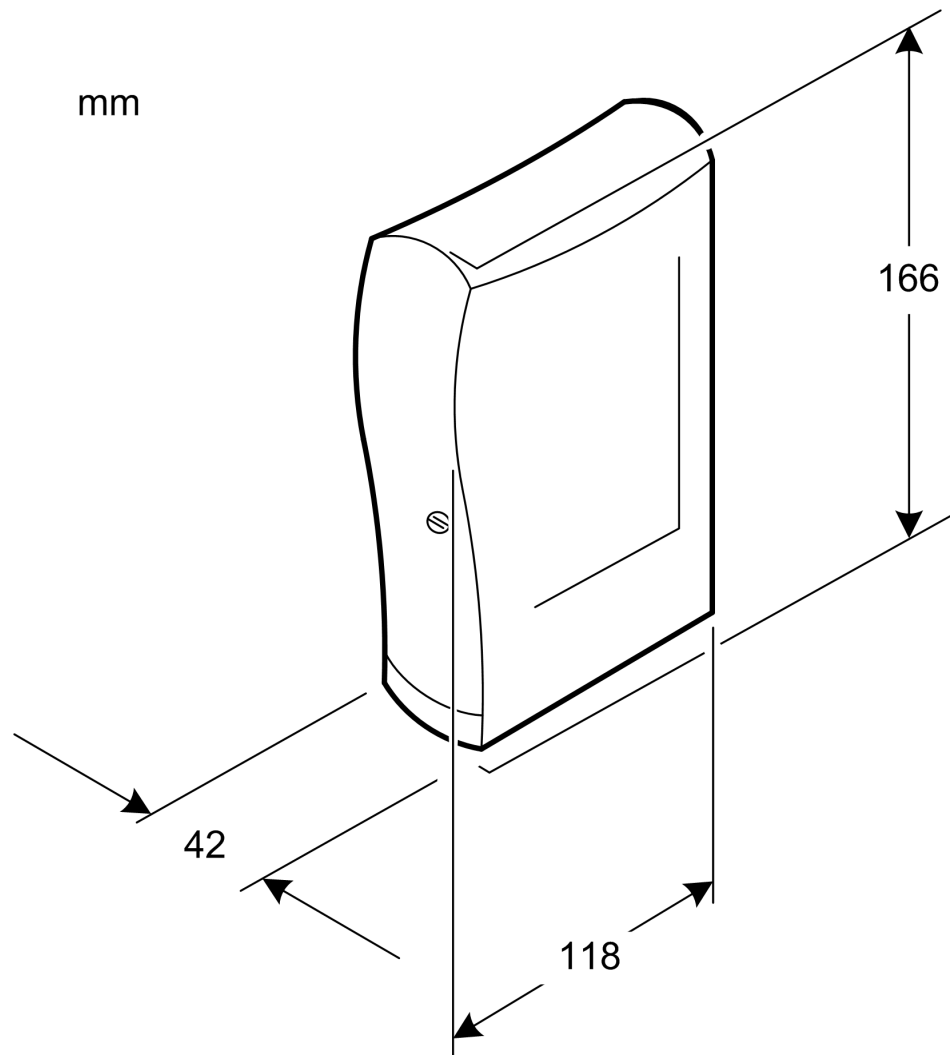

### Corrective Maintenance and Module Replacement

Scheduled maintenance consists of checking the I/O Module calibrations and proof tests. Detailed scheduled and corrective maintenance information is given in the AADvance Troubleshooting and Maintenance Manual Doc No: ICSTT-RM406. Corrective maintenance is by module replacement and where required fuse replacement in Termination Assemblies. In dual and triple modular redundant configurations, you can remove a module and install a new one without interrupting the system operation. In simplex configurations removing a module will interrupt the system operation. However, certain restrictions apply on module replacement timing for Safety Related systems (see the AADvance Safety Manual - ICSTT-RM446 for guidance).

Field connection wiring is attached at the connectors on the termination assemblies. Ethernet and Serial data connections are made at the T9100



Processor Base Unit. There are no physical links needed to be set up on any modules or base units. Standard modules are used for all the different configurations.

---

**IMPORTANT** Processor modules must be replaced with a module containing the same firmware revision, you cannot use processor modules with different firmware revisions on the same controller.

---

## Processor Back-up Battery

The 9110 processor module has a back-up battery that powers its internal Real Time Clock (RTC) and a part of the volatile memory (RAM). The battery only supplies power when the processor module is no longer powered from the system power supplies. The specific functions that the battery maintains on complete loss of power are:

- Real Time Clock - The battery supplies power to the RTC chip itself.
- Retained Variables - Data for retained variables is stored at the end of each application scan in a portion of RAM, backed up by the battery. On restoration of power the retained data is loaded back into the variables assigned as retained variables for use by the application.
- Diagnostic logs - The processor diagnostic logs are stored in the portion of RAM backed by the battery.

The battery has a design life of 10 years when the processor module is continually powered; for processor modules that are un-powered, the design life is up to 6 months. Battery design life is based on operating at a constant 25°C and low humidity. High humidity, temperature and frequent power cycles will shorten the operational life of the battery.

### *Low Battery Alarm*

A variable is available in the Workbench that can be set up and report the battery status. It will give an alarm and set a warning light on the processor front panel when the battery voltage is low.

### *Disabling the Low Battery Alarm*

For applications that do not require Real Time Clock functionality, or there are specific constraints, for example, the controller is in an inaccessible location, that make it necessary to remove the battery when the system is installed and set up, the battery failure alarm can be disabled at the Workbench.

### Battery Location

The battery is supplied separately and inserted into a slot behind a removable cover on the front panel of the processor module. The battery position is shown in the illustration:



**CAUTION:** The battery may explode if mistreated. Do not recharge, disassemble or dispose of in a fire.

---

### Battery Specification

A Polycarbon monofluoride Lithium Coin Battery with a nominal voltage of 3V; Nominal capacity (mAh) 190; Continuous standard load (mA) 0.03; Operating temperature range -30°C to +80°C, manufactured by Panasonic.



## Expansion Cable

This is used to add extra rows of I/O base units and modules.

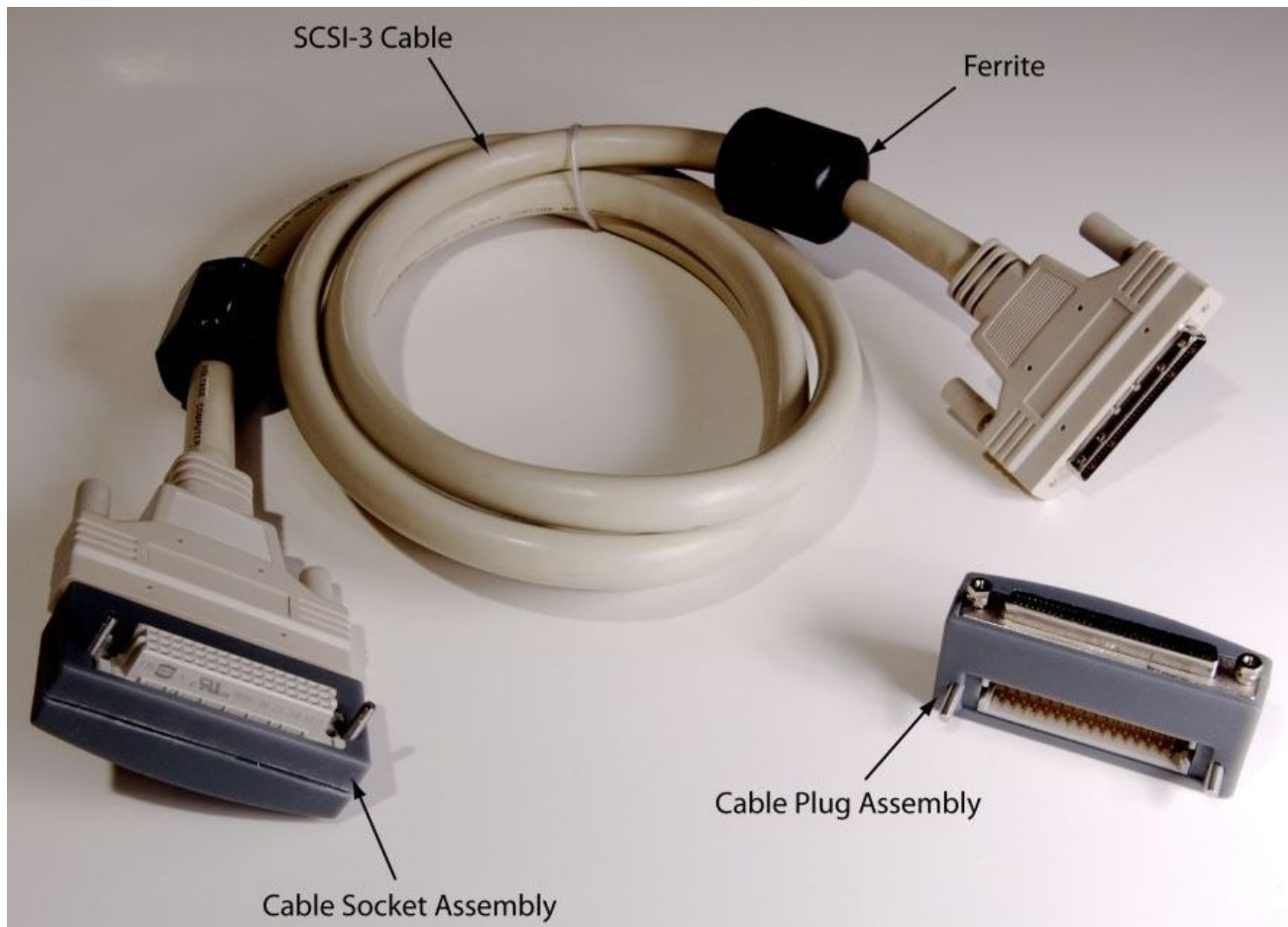

## Technical Features

### TUV Approved Operating System

The AADvance system runs an IEC 61508 approved operating system and the overall system is certified to IEC 61508, Part 1-7: 1998 - 2000 SIL 3.

### Internal Diagnostics and Fault Reset

The AADvance controller contains comprehensive internal diagnostic systems to identify faults that occur during operation and trigger warnings and status indications. The diagnostic systems run automatically and test the system for faults related to the controller, and field faults related to field I/O circuits. Serious problems are reported immediately, but faults that are not on non-critical items are filtered to help prevent spurious alarms. The diagnostic systems monitor such items at regular times, and need a number of occurrences of a possible fault before reporting it as a problem.

The diagnostic systems use simple LED status indications to report a problem. The LED indications identify the module and can also identify the channel

where the fault has occurred. There is also a summary system healthy indication for all of the controller. The application software uses its variable structures to report a fault problem; these variables give status reports and are configured using the AADvance Workbench.

Faults in the processor modules are none latching. The controller will recover automatically and the fault indication will clear once the fault condition has been removed. Faults in the I/O modules are latched. To clear them a fault reset signal is sent from the processor module by pressing the Fault Reset button on the processor module front panel. Field faults are not latched and will clear as soon as the field fault is repaired.

When the Fault Reset button on each processor module is pressed it attempts to clear a fault indication immediately, however, the diagnostic systems will report a serious problem again so quickly there will be no visible change in the fault status indications.

### **Remote Fault Reset**

Using the Workbench software you can set up a fault reset variable to mimic pressing the Fault Reset button on the front panel. This feature is provided for systems located in inaccessible locations. Refer to the AADvance Configuration Guide Doc No: ICSTT-RM458 for Workbench 2.x; regarding instructions on how to set up the variable.

## Controller Internal Bus Structure

Internal communication between the processor modules and I/O modules is supported by command and response busses that are routed across the processor and I/O base units.

The processor modules acts like a communications master, sending commands to its I/O modules and processing their returned responses. The two command busses I/O Bus 1 and I/O Bus 2 take the commands from the processor to the I/O modules on a multi-drop basis. An inter-processor link (IPL) supplies the communication links between dual or triple processor modules.

Each I/O module has a dedicated response line which returns to the processor. The unique response line for each I/O module supplies an unambiguous identification of the source of the I/O data and assists with fault containment.

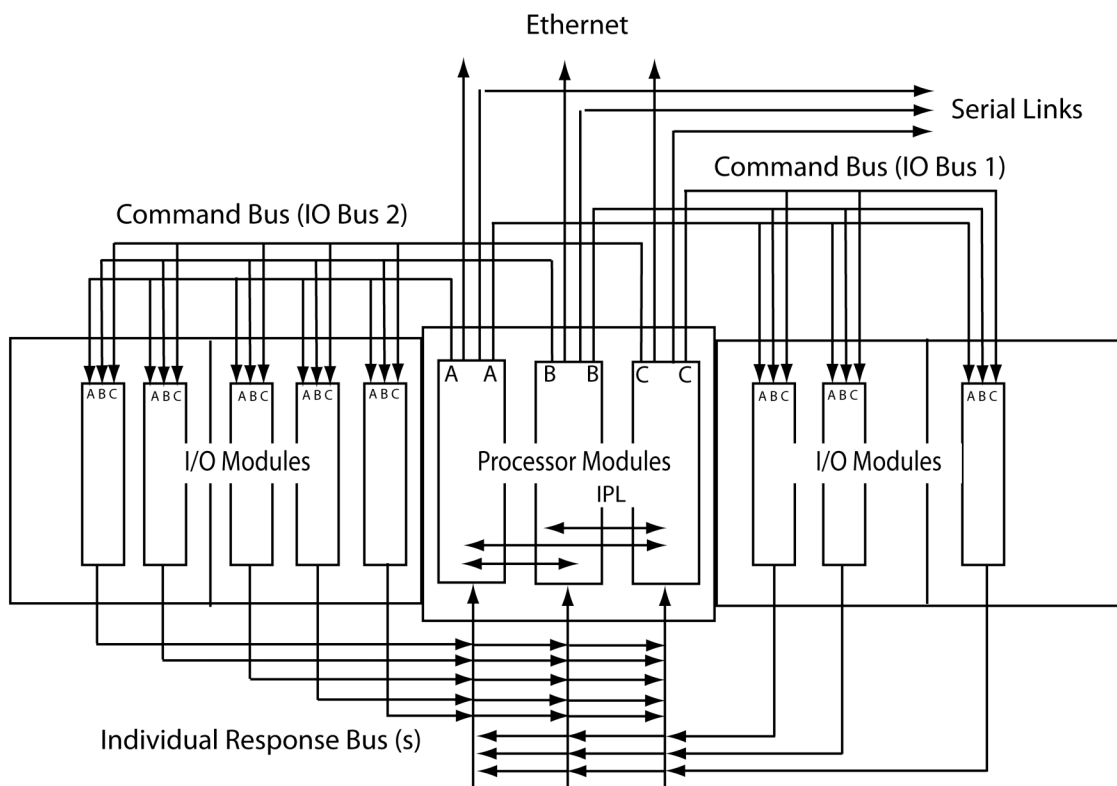

## On-line updates I/O Configuration Changes

The AADvance controller modular design makes it easy to create and change the I/O configuration. The on-line update facility enables you to make changes to the I/O configuration after the system is commissioned.

An on-line update can be used for the following changes.

- Expand a system and add new I/O modules, base units and termination assemblies.
- Change the module type in a simplex or group arrangement.
- Expand a simplex or group arrangement.
- Downgrade a group arrangement.
- Move a module to a different slot.
- Change an application variable.

You only have to plug an additional I/O base unit into the side socket on an installed I/O base unit. The command busses on the I/O base units do not need different terminations on the open ends of transmission lines, and the data response busses and power sources are supplied across all I/O base units. Termination assemblies are pushed into the I/O base unit for the additional I/O modules. To put the new modules on-line and make the changes to the system fully operational, the hardware configuration in the AADvance® Workbench software must be updated by an on-line update.

---

**IMPORTANT** For Release 1.3 you can change the I/O module configuration with an on-line update. However, if you are using an earlier product release the I/O configuration cannot be changed with an on-line update.

---



---

**IMPORTANT** An on-line update could affect the operation of the controller such that the application is stopped or the I/O data flow is interrupted. The AADvance Safety Manual outlines the precautions you need to follow when doing on-line updates on a Safety System.

---

When there is not sufficient space for extra I/O base units on a row you can use the Expansion Cable to connect a new row of I/O base units and modules to further expand the I/O system.

## Hot Swap I/O for Business Critical Channels

You can add a "hot swap" capability for business critical data channels. By installing a single I/O module into a dual TA. When a dual TA is configured you are leaving an empty spare slot for a replacement I/O module when a fault occurs. You can insert a new I/O module into the spare slot and restore a failed channel without interrupting the operation of the other channels.



Configure this "hot swap" arrangement when you configure your system at installation and set up time.

## Processor Firmware Upgrades

You can check the firmware revision of you processor modules without removing them to read the label and you can upgrade the firmware revision of the processor modules. Upgrading the firmware in the 9110 processor module is done in the Recovery Mode and is a two-stage process:

- Stage 1: Run the latest version of 350720\_xxx\_ControlFLASH.msi program to install the ControlFLASH™ firmware upgrade kit for the Recovery Mode on your PC. Then run the ControlFLASH utility to

upgrade your processor module and install the Recovery Mode. If your module is delivered with the Recovery Mode installed then this stage is not necessary.

Stage 1 must be performed individually on each processor; it does not matter if you download the Recovery Mode one at a time in a specific slot or in their own slots.

- Stage 2: Reboot the processor and press and hold the Fault Reset button to enter the Recovery Mode. Then run the latest version of 354400\_xxxx\_ControlFLASH.msi program to install the ControlFLASH to upgrade your processor's OS, FPGA, LSP and BUSP.

When stage 1 is completed ControlFLASH can be used to upgrade three processor modules in the same processor base unit all at the same time.

---

**NOTE** Detailed information and procedures on firmware revision are given in the AADvance Configuration Guide Doc No: ICSTT-RM405 and AADvance Configuration Guide Doc No: ICSTT-RM458 for Workbench 2.0.

---

### *Tools and Resources*

You will need the ControlFLASH firmware upgrade kit.

- Quick Start and RSLinx® Classic Lite software or better.
- ControlFLASH programming tool, along with its required support drivers and on line HELP.
- Firmware for the processor modules being upgraded.

## Ethernet Communication Protocols

AADvance Ethernet ports are used to support several transport layer services; these services are listed in the following table:

Protocol	Port Number	Purpose
TCP	502	MODBUS Slave
TCP	1132	ISaGRAF®, application downloads, debug, SoE
TCP	10001-10006	Transparent Communication Interface (Serial Tunnelling)
TCP	4818	CIP™ Produce & Consume
TCP	N/A	Telnet (diagnostic Interface)
UDP	1123,1124	IXL Bindings
UDP	2010	Discovery and configuration Protocol
UDP	2222	CIP Produce & Consume I/O
UDP	5000	Trusted® peer-to-peer
UDP	44818	CIP Produce & Consume

## The AADvance Workbench and Software Development Environment

The AADvance software lets you design one complete control strategy, and then target parts of the strategy to individual controllers. Interaction between the resources is automatic, significantly reducing the complexity of configuration in a multi-resource system. Programs can be simulated and tested on the workstation computer before downloading to the controller.

The workstation software is compliant with the IEC-61131 industrial standard and has several powerful features:

- the regulation of the flow of control decisions for an interacting distributed control system
- providing for the consistency of data
- providing a means for synchronous operation between devices
- mitigating the need to have separate synchronous schemes
- easing the development and maintenance of robust systems

The Workbench is a software development environment for a controller. It lets you create local and distributed control applications using the five languages of IEC 61131-3. (Instruction List (IL) and Sequential Function Chart (SFC) languages are not supported by AADvance Workbench 2.0). Engineers can use one language or a combination that best suits their knowledge and programming style and the type of application.

The Workbench is a secure development environment. There is also a Program Enable key that must be plugged into the processor base unit to allow the user to modify and download the application resource or access the AADvance Discover tool to set or change the controller IP address. The Program Enable Key when it is removed protects the application from unauthorized access.

The development environment includes:

- tools for program development
- program documentation
- function block library management
- application archiving
- database configuration
- import/export utilities
- on-line monitoring
- off-line simulation and controlled on-line changes
- Programs can be simulated and tested on the computer before downloading to the controller hardware. Also supplied are a set of configuration tools that enables you to define the hardware architecture in the software; set up the processor functionality; and connect application variables to the Workbench application resource program that will monitor processor and I/O module status information and report I/O channel data values to the Workbench. Resource Control applications can be distributed across several hardware platforms, communicating with each other through secure networks.

## Operating Systems (32 or 64 bit)

The minimum workstation requirements for the application development software are as follows:

- Microsoft® Windows XP Service Pack 3



**CAUTION:** Do not use XP Professional x64 Edition.

---

- Windows Vista
- Windows 7
- Microsoft Windows Server 2003
- Microsoft Windows Server 2008

---

**IMPORTANT** For Workbench 1.3 Network Licensing - Windows 64-bit version will only work with the USB license key and will not recognize a Workbench software license key.

---

Hardware:

- 1.6 GHz CPU
- 1 GB RAM (32-bit) or 2 GB RAM (64-bit) (add 512 MB if running in a virtual machine)
- DirectX 9 capable video card running at 1024 x 768 resolution display
- 5,400 RPM hard disk
- 3 GB available hard disk space
- DVD drive or network connection, to read software distribution files

---

**NOTE** If the application is Workbench 1.3 and adopts the USB dongle licensing option the workstation PC will require one free USB port.

---

- Network port (10/100 Base T Ethernet), for communications with the controller

It is recommended that the PC has a 2.2 GHz or higher CPU; 1,024 MB or more RAM, a 1,280 x 1,024 display and a 7,200 RPM or higher hard disk.

It is also recommended that the hard disk has at least 10 GB free space. This provides sufficient space to hold the distribution zip file, the unzipped source files and the installed program files, and also enough space for Windows to operate reasonably quickly. You can get back a lot of this space by deleting the source files after finishing the installation.

## Importing and Exporting Data

The AADvance Workbench can import and export existing data in standard file formats such as Microsoft Excel.



## AADvance Workbench Licensing

The AADvance Workbench is licensed software. There are three types of license: full, single controller and demo.

- The single controller license is applicable for applications which use only one controller. The software features which add a second or subsequent controller to the project are disabled, and you cannot open an existing project which uses more than one controller.
- The full license supplies all of the features of the AADvance Workbench. It is applicable for applications with one or more controllers.
- The demo license is like a full license, but with a time limit. You can use all of the features of the AADvance Workbench for up to 30 days after first running the AADvance Workbench is first run.

A demo license is supplied free of charge for a first installation on a computer. You change the demo license to a single controller license or a full license by purchasing an unlock code from Rockwell Automation, and entering the code into the software. When you use the demo license, the AADvance Workbench displays a Demo License window each time you try to open a project. The window includes the contact details at Rockwell Automation required for purchasing a license.

If you try to use the demo license for more than 30 days, the license expires. You cannot open a project or create a new one until you purchase a license.

## Controller Functionality

This chapter describes the controller functions that give you the flexibility to create a system to meet your specific business needs.

### Field Data Handling

The AADvance® controller is a logic solver and I/O processing device. The field data and field element control commands are routed across the field wiring to the termination assemblies which are uniquely matched to their respective I/O modules. An internal bus structure and a secure communication protocol transport the data and command signals to and from the processing software.

The processor has a SIL 3 rated operating system and runs user developed applications to analyze and respond to the field data and produce the necessary field commands and user information. These application programs, developed by the user to meet their safety and business requirements are downloaded from a Workstation that has the AADvance Workbench application development software installed. A security device on the processor backplane helps prevent unauthorized access to the application software.

### Process Safety Time

The Process Safety Time (PST) setting defines the maximum time that the processor will let the outputs stay in the ON state if certain internal diagnostic faults or systematic application faults occur. If the process safety time expires the controller will go to its "safe state". The PST must be specified for the whole controller, this is a top level setting that you make once for the whole controller and is set at the processor module. I/O modules can be set at a lower PST but must not go over this overall setting.

An AADvance controller adopts a default value for the PST = 2500 ms which can be adjusted to meet your system requirements by using the following simple equation:

$$PST \leq \frac{PST_{euc}}{2} - \left( \text{sensor delay} + \text{actuator delay} \right)$$

where PST<sub>euc</sub> is the process safety time for the equipment under control.

### SNTP

The AADvance controller supports the Simple Network Time Protocol (SNTP) service that can circulate an accurate time around the network. As an SNTP

client the controller will accept the current time from external Network Time Protocol (NTP) and SNTP network time servers.

SNTP clients settings tell the controller the IP address of the external server; the version of SNTP offered by the server; and the operating mode for the time synchronization signal that the processors will use for their real time clock.

An AADvance controller can also fulfill the role of one or more SNTP servers (one for each processor) to supply a network time signal throughout the network. To enable server time on an interface it is necessary to give the direct broadcast address for that interface. This works for broadcast or unicast modes. This way of configuring is derived from the NTP configuration command language.

## CIP and its Producer and Consumer Variables

You can configure CIP produce and consume variables for an AADvance controller.

One or more controller Ethernet ports may be used for CIP communications so long as they are on separate subnets.

Consideration must be given to the number and mix of produce/consume variables being used.

Each CIP consumer variable identifies the ControlLogix® controller and the tag produced by that controller, which provides a value to be consumed.

The AADvance controller sets its consumer variables to the most recent received value at the start of its application scan, before executing the logic. The controller updates its producer variables at the end of its application scan, after executing the logic. The AADvance controller uses the most recent value of a producer variable when sending a packet.

You cannot define a default value for a consumer variable. If the connection fails (typically because the communications link fails), the most recently received value of the consumer variable is retained. The maximum size of a CIP variable is 500 bytes.

If the variable is a structure having a mixture of element types, then each element starts on a new byte or word depending on its size. For example, a DINT following a single bit BOOL will start on a new 4 byte boundary.

Also:

- A LINT Must **ALWAYS** align on a 64 bit (8byte) boundary.
- Any UDT that contains a LINT must **ALWAYS** be of a size that is divisible by 8 bytes

---

**IMPORTANT** Only use CIP produce/consume between AADvance and ControlLogix Controllers. For data being exchanged between AADvance Controllers use bindings and SNCP network.

---

For produce/consume **with status** the producing/consuming UDTs **must** be identical. This means that not only must elements of the UDT be of the same type but the UDT name itself must be identical in both controllers.

## HART

HART variables can be configured on each analogue input and output channel to monitor the HART field device.

Make sure that your HART field devices support HART command 0 ('read unique ID') and HART command 3 ('read current and four dynamic variables'). The AADvance controller uses these commands to communicate with the HART devices.

The AADvance analogue input and output modules use HART command #03 to collect data from the field device as specified by Revision 5 of the HART specification. The extra data available from HART-enabled field devices is reported to the application in custom data structures: T9K\_AI\_HART and T9K\_AI\_HART\_FULL.

The structures supply the following data:

- Loop current in milliamps
- Process measurement in engineering units
- Errors on HART communication seen by the field device
- Status of the field device
- Time since the most recent update, in milliseconds

You can use the loop current variable for diagnostic checks in the application, to compare the value of the variable with the value on the 4 to 20 mA loop and react if there is a discrepancy. You can also monitor the status of the field device and use this to report diagnostic errors and manual configuration changes.

---

**IMPORTANT** The update rate for HART data from field devices is slower than the update rate for the 4 to 20 mA analogue signal itself. HART data can take a maximum of 4 seconds to update, depending on the device type and configuration.

---

## Bindings and the SNCP Network

Bindings are based on a producer/consumer model. The controller consuming the data establishes a binding link with the controller producing the data and manages all of the sending and receiving of data. It schedules the sending and receiving of data, sending the diagnostic data, managing the safety response if faults occur and managing the communications redundancy. An SNCP network is illustrated in the diagram.

First there must be a physical connection between the two controllers. The design of the Ethernet network and the equipment used does not impact the SIL rating of the communications interface, but the design of the network does change the reliability of the network and does impact the spurious trip rate. SNCP Network data can be combined on a common network resulting in safety and non-safety data sharing a common physical network. This does not compromise the SIL rating of the network but again does introduce failure modes and possibly security risks which can increase the spurious trip rate. Therefore, careful consideration must be given to the network topology during the applications specification and design phase.

SNCP Networks can be configured as Simplex (Fail Safe) or Redundant (Fault tolerant). The network configuration is dependent on the applications safety

and availability requirements. The giving and receiving of data occurs independently from the physical network configuration as the connection between the controllers is treated as a logical network

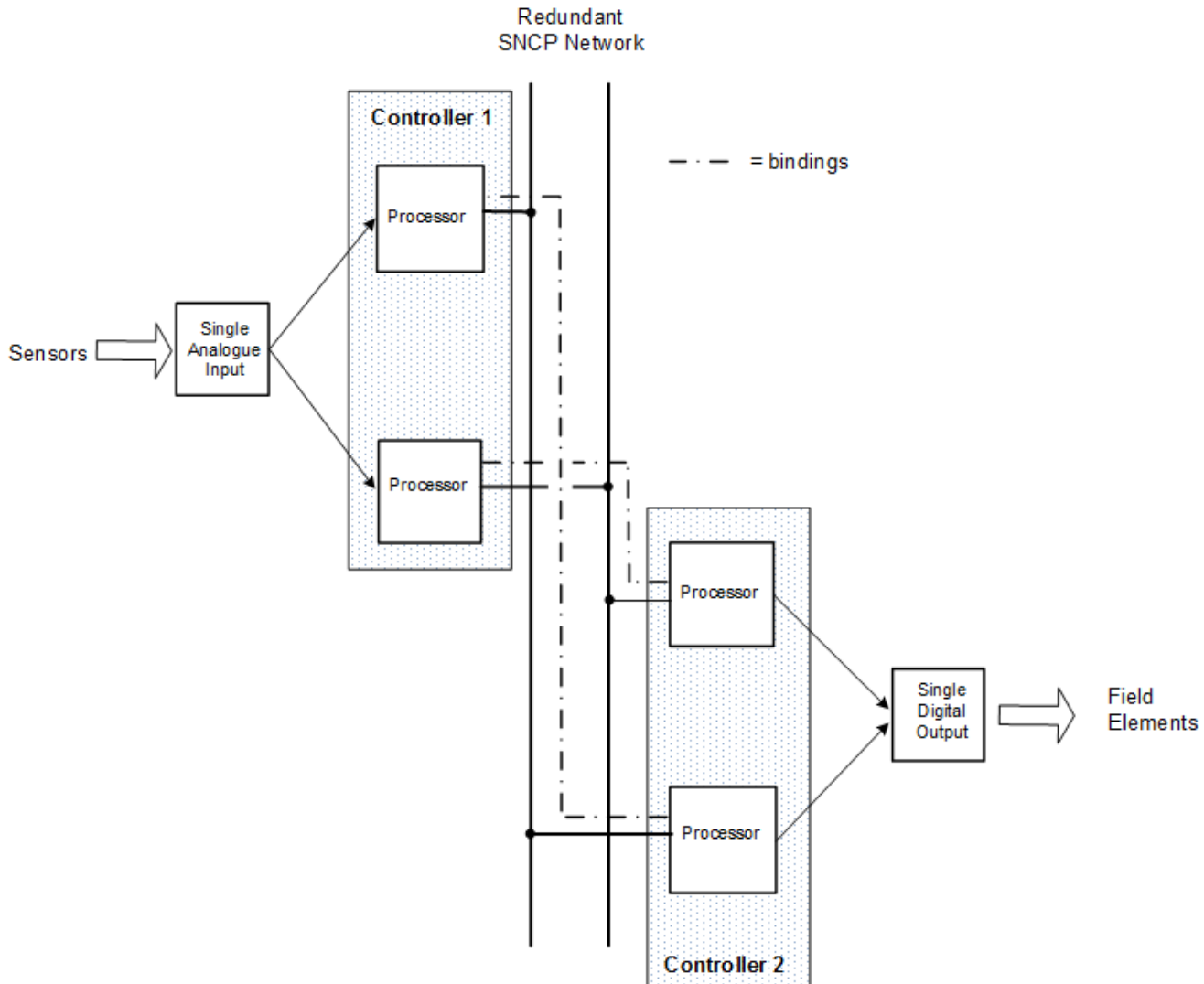

## Serial Communication Interface

Two serial ports on each processor module support the following signal modes depending on their use:

- RS485fd: A four-wire full duplex connection that features different busses for transmit and receive. This selection must also be used when the controller is acting as a MODBUS Master using the optional four-wire definition specified in Section 3.3.3 of the MODBUS-over-serial standard.
- RS485fdmux: A four-wire full-duplex connection with tri-state outputs on the transmit connections. This must be used when the controller is acting as a MODBUS Slave on a four-wire bus.
- RS485hdmux: A two-wire half duplex connection applicable for or master slave or slave use. This is shown in the MODBUS-over-serial standard.

## Time Synchronization SNTP

The AADvance controller can be configured to operate as an SNTP client or server or both.

- The SNTP client settings inform the controller of the following information: the IP address of the SNTP server the version of SNTP offered by the server and the operating mode for the time synchronization signal that the processors will use for their real-time clock. The processor module can be configured as a unicast or broadcast client.
- The AADvance controller can also fulfill the role of an SNTP server. To enable serving of time on an interface, you need to enable the interface and then you need to specify the direct broadcast address for that interface. This works for broadcast or unicast modes. When the controller is configured as a broadcast server, the controller can still respond to unicast requests from clients.
- Configure the controller as both a client and a server if using an external time server and you want to use the controller to supply the time data to other controllers and devices.

---

**IMPORTANT** Changes to the SNTP settings are not active until after the power is cycled.

---

## MODBUS Master

The AADvance controller can be used as a MODBUS Master to one or more MODBUS Slave devices. Slave devices can include programmable logic controllers, remote devices (typically with little or no processing ability) and, more rarely, other functional safety controllers (Trusted® or AADvance).

The controller supports the MODBUS RTU and MODBUS TCP protocols, as well as a subset of MODBUS commands. You can use MODBUS RTU with point-to-point and multi-drop serial links, and MODBUS TCP with Ethernet.

---

**NOTE** The AADvance controller does not support the MODBUS ASCII protocol.

---

You can set up a list of messages (commands) for each slave device. MODBUS read commands cause data to read from the slave device to the MODBUS Master, while MODBUS write commands cause data to be copied from the MODBUS Master to the slave device. You can also define a sequence of broadcast write commands, which a MODBUS Master can send to multiple MODBUS RTU slaves without requiring an acknowledgment. The AADvance controller can control and monitor each of the MODBUS Master objects and their slave links.





---

**WARNING:** The MODBUS Master functionality has a safety integrity level of zero (SIL 0) and must only be used for non-safety applications.

---

## MODBUS Master Hardware and Physical Connections

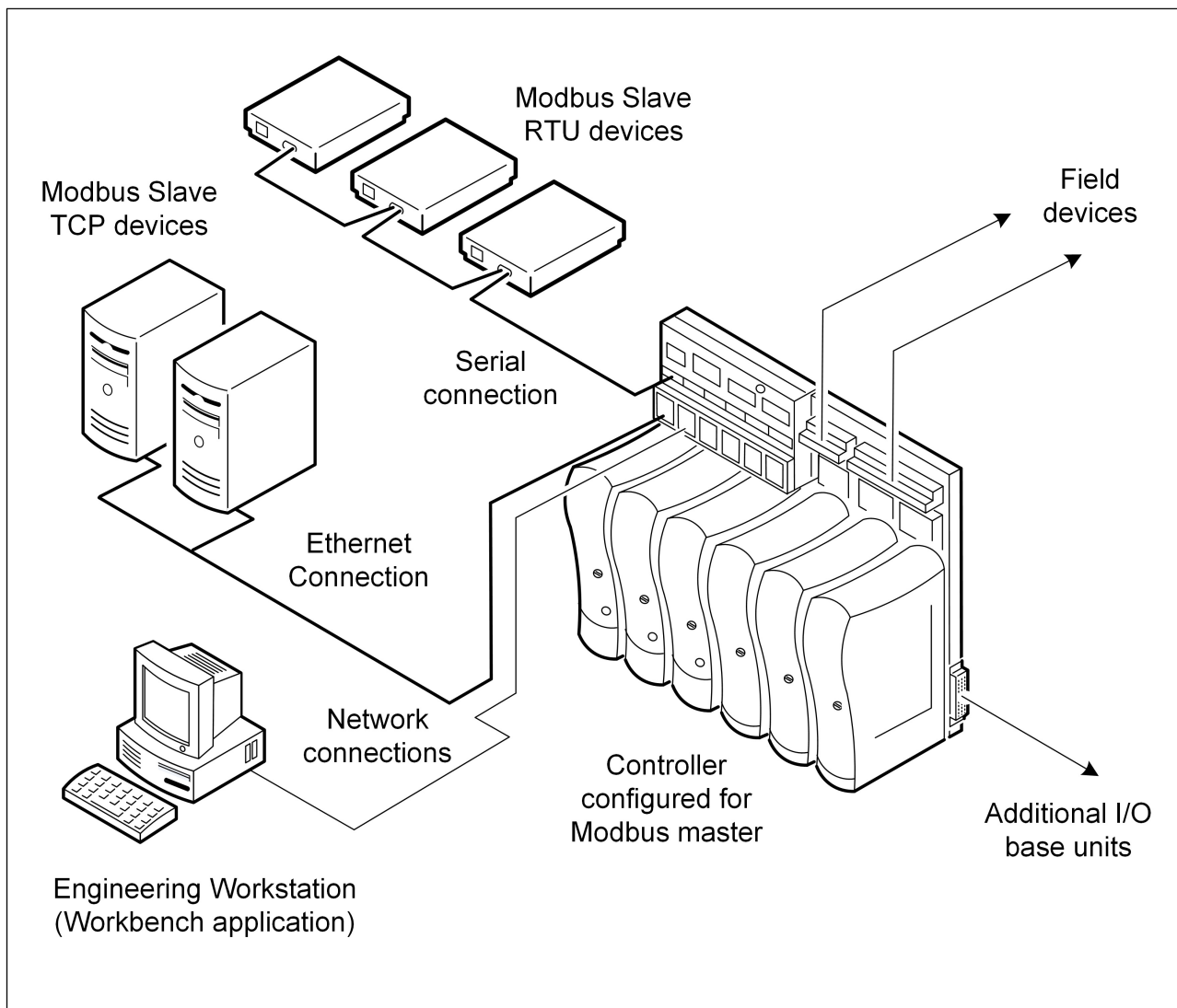
The MODBUS Master functionality is built into the 9110 Processor Module. The physical communication ports are located on the 9100 Processor Base Unit. You do not need to add any other hardware to the AADvance controller apart from other components to make the physical connections to the processor base unit. The following illustration shows some possible arrangements for MODBUS Master connections.



The MODBUS RTU slave devices are connected to one or more of the serial ports on the controller; a usual arrangement uses a multi-drop (RS-485) arrangement. The engineering workstation and the MODBUS TCP devices are shown connected to the Ethernet ports on different networks. Alternatively, these devices can be combined onto one network. Refer to the AADvance System Build Manual for more details about physical connections

## Controller IP Address

The AADvance controller stores its IP address data in non-volatile memory in the 9100 processor base unit. The data is independent of the 9110 processor modules in the controller, and so the controller keeps the address information when you remove a processor module.

You must set up the IP address data when you create a new system, or if you fit a new processor base unit.

After having set up the IP address data in the controller, you can configure the AADvance Workbench to find the controller on the network.



## Recovery Mode

Recovery Mode is a shutdown mode and uses a base level firmware. It is entered automatically when a critical firmware failure occurs or it can be entered manually by pressing the processor Fault Reset button immediately after the module has booted up. The Recovery Mode is also used when you want to download a new firmware upgrade.

As an alternative firmware version it allows the following maintenance activities:

- Update the firmware using the ControlFLASH™ utility
- Program the processor IP Address with the AADvance Discover utility
- Extract diagnostic information

In Recovery Mode the Ready, Run, Force and Aux LEDs go Amber and the Healthy and System Healthy LEDs stay Green. The System Healthy and Healthy LEDs could go Red if a fault is detected while in the Recovery Mode.

---

**NOTE** When in Recovery Mode the I/O communications are disabled and the Application code is not running.

---

## Differential Services (DiffServ)

Differentiated services (DiffServ) gives a simple and coarse method to classify the services of different applications, and thus specify the priority of IP traffic. DiffServ is useful to make sure that high priority services are not delayed (or less delayed) during periods of network congestion. When applied, the service uses bit patterns in the "DS-byte" of IP, which for IPv4 is Type-of-Service (ToS) octet.

When you configure DiffServ you apply a priority value to a service and thus identify it as different to less important services. You do this by arranging routers or switches that can examine IP headers and prioritize them by the ToS header octet. The network devices will then apply their rules to prioritize IP traffic. The AADvance controller maintains the priority when it responds to incoming messages, and sets a priority according to the configuration for the messages it sends out.

If you use DiffServ, the controller scan rate can be up to 5 ms larger or smaller than the scan rate when DiffServ feature is disabled.

The TCP/IP stack can apply the user-specified ToS data in its datagrams during the TCP negotiation (this is the 3-way handshake, RFC 793). You can specify this behavior when you set up DiffServ.

---

**IMPORTANT** The DiffServ feature is only available with release 1.3 onwards of the AADvance Workbench and controller.

---

## Serial Tunneling

Not available for Workbench 2.0.

## Ethernet Forwarding

The Ethernet forwarding property lets an AADvance controller forward Ethernet packets intended for a third party device, as shown in the illustration, together with all broadcast and multicast messages.

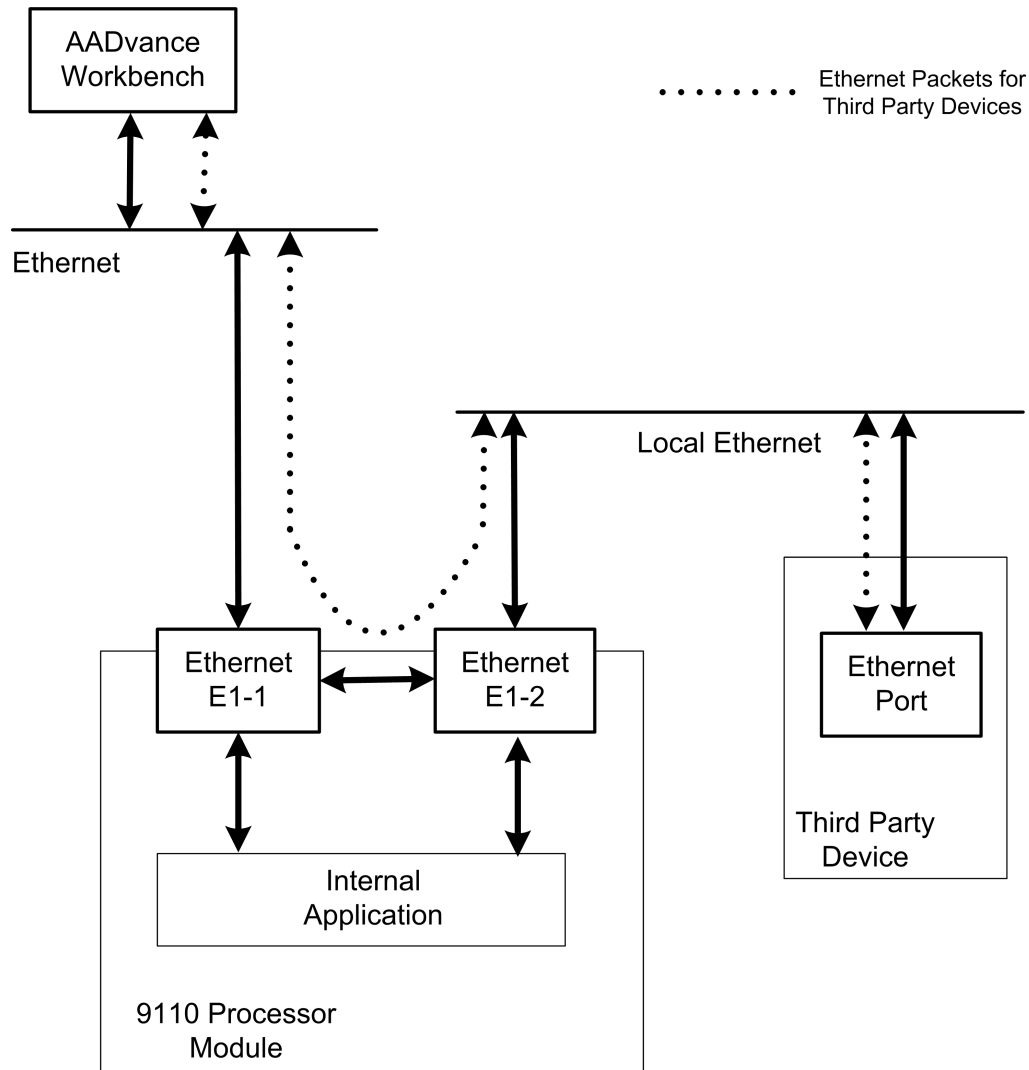

When Ethernet forwarding is enabled, each 9110 processor module in the controller forwards unicast messages intended for other devices, and all broadcast and multicast messages, between its two Ethernet ports. A device connected through the processor module can get its IP configuration through BOOTP or DHCP, or statically.

The processor module in the first position (slot) in the 9100 processor base unit forwards these messages from port E1-1 to E1-2, and in the opposite direction from port E1-2 to E1-1. Similarly (if fitted), the processor module in the second position in the 9100 processor base unit forwards traffic from port E2-1 to E2-2, and from port E2-2 to E2-1. The third processor module (if fitted) forwards traffic from port E3-1 to E3-2, and from port E3-2 to E3-1. In each case, the second of these ports represents an uplink to the remainder of the network or (if applicable) to a different network. A device connected to this port sees all the traffic which can be of use to it: broadcasts, multicasts, and unicast traffic not destined for the 9110.

The processor module continues to consume the unicast messages intended for itself, and all broadcast and multicast messages, as it does when Ethernet Forwarding is disabled.

Ethernet forwarding is not designed to make links from one processor module to a different processor module, for example from ports E1-2 to E2-1 and E2-2 to E3-1. Do not do this.

The controller keeps its Ethernet forwarding setting if you change one or more of the 9110 processor modules. You do not have to change the setting during corrective maintenance.

## Compiler Verification Tool

The Compiler Verification Tool (CVT) is a software utility that validates the output of the application compilation procedure. It is automatically enabled for resources when a project is created and when you add a resource to an existing project. This procedure in conjunction with the validated execution code produced by the AADvance Workbench confirms that there are no errors introduced by the Compiler during the development of the application.

To achieve this CVT decompiles the application project file and then compares each individual application project (POU) source files with its decomposed version. The CVT analysis is displayed in the Workbench window.

## The OPC Portal Server

The OPC Portal Server is a windows-based application that allows OPC compatible clients, such as HMIs and SCADA systems, to connect to one or more AADvance controllers to access process data. It conforms to version 1.10 of the Alarms and Events Standard published by the OPC Foundation.

**Notes:**

## AADvance System Architectures

An AADvance® controller can be configured to manage non-safety and up to SIL 3 safety related system requirements for low demand or high demand fault tolerant applications.

This chapter describes the different system architectures that can be configured for SIL 2 and SIL 3 applications.

---

**NOTE** Architectures are independent of I/O module capacity so 8 or 16 channel I/O modules can be used.

---

### SIL 2 Architectures

SIL 2 architectures are recommended for fail-safe low demand applications. All SIL 2 architectures can be used for energize or de-energize to trip applications. In any configuration when a faulty processor or input module is replaced then the previous fault tolerance level is restored. For example in a fault tolerant input arrangement and one module is faulty then the system will degrade to 1001 (1 out of 1 with diagnostics), by replacing the faulty module the configuration is restored to 1002D (1 out of two with diagnostics).

In all SIL 2 architectures, when the processor modules have degraded to 1001D on the first detected fault, the system must be restored to 1002D by replacing the faulty processor module within the MTTR assumed in the PFD calculations; also, unless compensating measures are defined in the Safety Requirements Specification (SRS) and documented in operating procedures, the application program must be designed to shut down safety instrumented functions if a module failure due to a dangerous fault has not been replaced within the MTTR.

### SIL 2 Fail-safe Architecture

The following is a simplex fail-safe SIL 2 architecture, where I/O modules operate in 1001D under no fault conditions and will fail-safe on the first detected fault. The processor will operate in 1002D under no fault conditions, will degrade to 1001D on the first fault in either processor module and will fail-safe when there are faults on both processor modules.

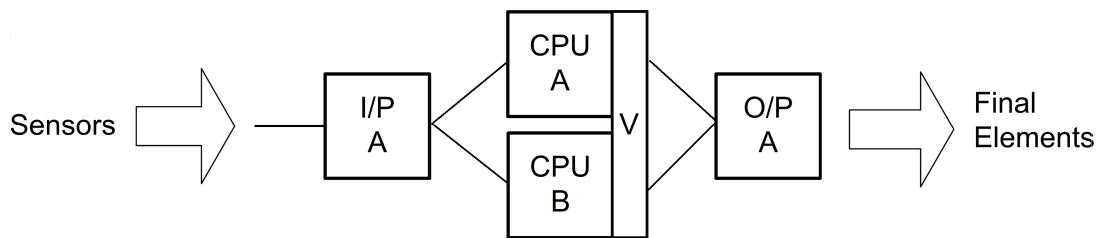

**NOTE** Simplex output modules used for energize to action applications can only be used for low demand applications.

**Table 5 - Modules for SIL 2 Fail-Safe Architecture**

Position	Module Type
I/P A	T9401/2 Digital Input Module, 24 Vdc, 8/16 Channel + T9801 Digital Input TA, 16 Channel, Simplex. or T9431/2 Analogue Input Module, 8/16 Channel + T9831 Analogue Input TA, 16 Channel, Simplex T9300 I/O Base Unit
CPU A	2 x T9110 Processor Module, T9100 Processor Base Unit
O/P A	T9451 Digital Output Module, 24 Vdc, 8 Channel, Isolated + T9851 Digital Output TA, 24 Vdc 8 Channel, Simplex 1 x T9481/T9842 Analogue Output Module, 3/8 Ch, Isolated + T9881 Analogue Output TA, 8 Ch, Simplex

### SIL 2 Fault Tolerant Input Architectures

A SIL 2 fault tolerant input architecture can have dual or triple input modules with a dual processor and single output modules. The illustration shows a dual input arrangement where the dual input modules operate in 1002D under no fault conditions, they degrade to 1001D on detection of the first fault in either module of the redundant pair, and when a fault occurs on the second module the controller fails-safe.

The processor operates in 1002D under no fault conditions, will degrade to 1001D on the first fault in either processor module and will fail-safe when there are faults on both processor modules. The output module operates in 1001D under no fault conditions and fail-safe on the first detected fault.

When a triple input module arrangement is configured the group of input modules operate in 2003D under no fault conditions, degrade to 1002D on the detection of first fault in any module, then degrade to 1001D on the detection of faults in any two modules and fail-safe when there are faults on all three modules.

**NOTE** Simplex output modules used for energize to action applications can only be used for low demand applications.



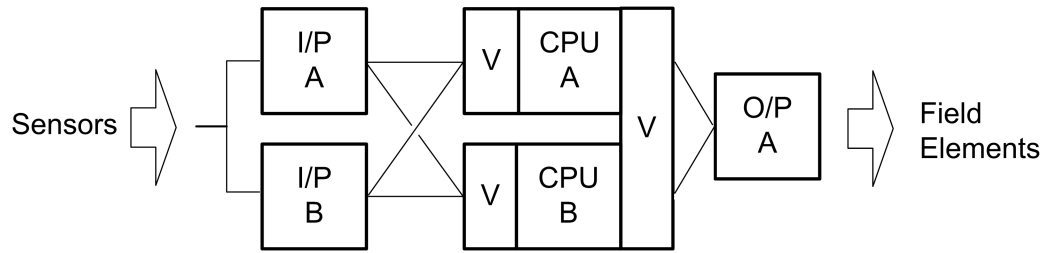

V = voting

**Table 6 - Modules for SIL 2 Architecture**

Position	Module Type
I/P A and B	2 x T9401/2 Digital Input Module, 24 Vdc, 8/16 Channel + T9802 Digital Input TA, 16 Channel, Dual or 2 x T9431/2 Analogue Input Module, 8/16 Channel, Isolated, + T9832 Analogue Input TA, 16 Channel, Dual T9300 I/O Base Unit
CPU A	2 x T9110 Processor Module, T9100 Base Unit
O/P A	T9451 Digital Output Module, 24 Vdc, 8 Channel + T9851 Digital Output TA, 24 Vdc, 8 Channel, Simplex; T9300 I/O Base Unit or 1 x T9481/T9842 Analogue Output Module, 3/8 Ch, Isolated + T9881 Analogue Output TA, 8 Ch, Simplex

### SIL 2 Fault Tolerant Output Architecture

A SIL 2 Fault Tolerant output architecture has a single output module with dual processor and single or redundant input modules.

The illustration shows a SIL 2 single output arrangement where the output module operates in 1001D under no fault conditions and fail-safe on the first detected fault. The processor will operate in 1002D under no fault conditions, will degrade to 1001D on the first fault in either processor module and will fail-safe when there are faults on both processor modules.

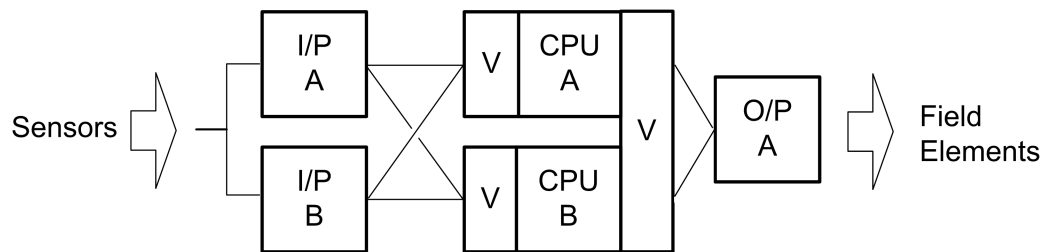

#### Digital Output

For digital output modules the following applies:

- If the required safe state is ON, you must use dual digital output modules for **High Demand** applications.

#### Analogue Output

For Analogue Output the following applies:

- The fail-safe state current of the analogue output module is less than 2 mA.
- A **safe state** is an output configured to go to a specific value, or configured to hold last state. If the required safe state is larger than 4 mA, you must use dual analogue output modules for **High Demand** applications.

**Table 7 - Modules for SIL 2 Fault Tolerant Output Architecture**

Position	Module Type
I/P A & B	T9401/2 Digital Input Module, 24 Vdc, 8/16 Channel + T9801 Digital Input TA, 16 Channel, Simplex or T9431/2 Analogue Input Module, 8/16 Channel + T9831 Analogue Input TA, 16 Channel, Simplex T9300 Base Unit
CPU A	2 x T910 Processor Module, T9100 Processor Base Unit
O/P A	T9451 Digital Output Module, 24 Vdc, 8 Channel + T9851 Digital Output TA, 24 Vdc, 8 Channel, Dual and T9300 I/O Base Unit or 1 x T9481/T9842 Analogue Output Module, 3/8 Channel, Isolated + T9881 Analogue Output TA, 8 Ch, Simplex

### SIL 2 Fault Tolerant Input and SIL 2 High Demand Architecture

A SIL 2 fault tolerant "High Demand" architecture has dual input, dual processor and dual output modules. In a dual arrangement the input modules operate in 1002D under no fault conditions, degrade to 1001D on the detection of the first fault in either module, and will fail-safe when there are faults on both modules.

A triple input module arrangement can also be configured if it is required to increase the fault tolerance of the input. When a triple input module arrangement is configured the input modules operate in a 2003D under no fault conditions, degrade to 1002D on detection of the first fault in any module, then degrade to 1001D on the detection of faults in any two modules, and will fail-safe when there are faults on all three modules.

The processor will operate in 1002D under no fault conditions, will degrade to 1001D on the first fault in either processor module and will fail-safe when there are faults on both processor modules. For high demand applications the processor must be repaired within the MTTR assumed in the PFD calculations or the high demand safety instrumented functions must be shut down.



**WARNING:** For **High Demand** applications you must use a minimum of a dual processor configuration. High demand energize to action applications will require dual output modules. (Analogue Output Modules where the normal output current is less than 4 mA are classed as energize to action applications).

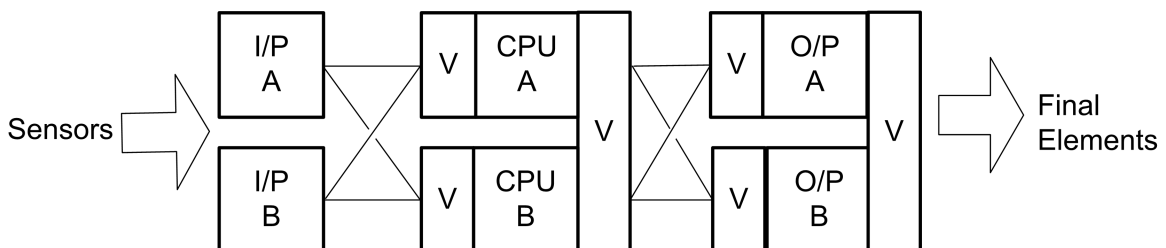



**WARNING:** For Continuous Mode applications the measures specified in this section for High Demand applications must be applied.

**Table 8 - Modules for SIL 2 Fault Tolerant High demand Architecture**

Position	Module Type
I/P A & B	2 × T9401/2 Digital Input Module, 24 Vdc, 8/16 Channel + T9802 Digital Input TA, 16 Channel, Dual or 2 × T9431/2 Analogue Input Module, 8/16 channel + T9832 Analogue Input TA, 16 Channel, Dual 1 × T9300 I/O Base unit
CPU A & CPU B	2 × T9110 Processor, T9100 Processor Base Unit
O/P A & B	2 × T9451 Digital Output Module, 24 Vdc, 8 Channel + T9852 Digital Output TA, 24 Vdc, 8 channel, T9300 Base Unit or 2 × T9481/T9842 Analogue Output Module, 3/8 Ch, Isolated + T9882 Analogue Output TA, 8 Ch, Dual and T9300 Base Unit

## SIL 3 Architectures

SIL 3 architectures have at least two or three processor modules and are applicable for use with:

- SIL 3 de-energize to trip applications.
- SIL 3 energize to action applications when fitted with dual digital output modules.
- SIL 3 high demand applications where the required safe state is more than 4 mA, when fitted with dual analogue output modules (A 'safe state' is an output configured to go to a specific value, or configured to hold last state).

Faulted input modules in a SIL 3 arrangement can be replaced without a time limit; faulted output modules must be replaced within the MTTR assumed in the PFD calculations.

In all SIL 3 architectures, when the processor modules have degraded to 1001D on the first detected fault, the system must be restored to at least 1002D by replacing the faulty processor module within the MTTR assumed in the PFD calculations or all SIL 3 safety instrumented function and high demand safety instrumented functions must be shut down.

### SIL 3 Fail-safe I/O, Fault Tolerant Processor

A SIL 3, fail-safe I/O with a fault tolerant processor architecture has a simplex input and output arrangement with dual or triple processor modules. The dual processor modules operate in 1002D under no fault conditions and degrade to 1001D on detection of the first fault in either module. When there are faults on both modules the configuration fails-safe.

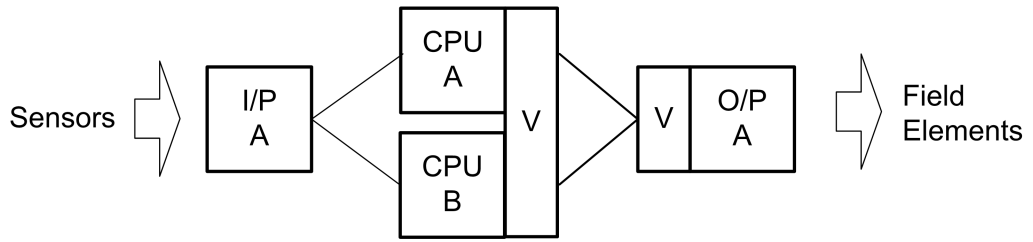

If required you can configure triple processor modules as a variation of this SIL 3 architecture. Using this arrangement the processor modules operate in 2003D under no fault conditions and 1002D on the detection of the first fault in any module. They degrade to 1001D on the detection of faults in any two modules and fail-safe when there are faults on all three modules.

*Digital Output Modules*

- For de-energize to action operation one 9451 output module is sufficient for SIL 3 requirements. However, for energize to action operation, dual digital output modules are required.
- A digital output module fault must be repaired within the MTTR which was used in the PFD calculation. This rule applies to simplex digital output modules in de-energize to trip applications and to dual digital output modules in energize to action applications.

*Analogue Output Modules*

- The fail-safe state current of the analogue output module is less than 2 mA.
- If the required safe state is more than 4 mA, you must use dual analogue output modules for high demand applications.
- An analogue output module fault must be repaired within the MTTR which was used in the PFD calculation. This rule applies to simplex analogue output modules where the safe state is less than or equal to 4 mA and to dual analogue output modules where the safe state is more than 4 mA.

**Table 9 - Modules for SIL 3 Fail-safe I/O, Fault Tolerant Processor**

Position	Module Type
I/P A	T9401/2 Digital Input Module, 24 Vdc, 8/16 Channel + T9801 Digital Input TA, 16 Channel, Simplex or T9431/2 Analogue Input Module, 8/16 channel + T9831 Analogue Input TA, 16 Channel, Simplex T9300 Base unit
CPU A & CPU B	2 x T9110 Processor Module, T9100 Base Unit
O/P A	1 x T9451 Digital Output Module, 24 Vdc, 8 Channel + T9851 Digital Output TA, 24 Vdc, 8 Channel, Simplex or 1 x T9481/T9842 Analogue Output Module, 3/8 Ch, Isolated + T9881 Analogue Output TA, 8 Ch, Simplex

**SIL 3 Fault Tolerant I/O Architectures**

A SIL 3 fault tolerant I/O is achieved by dual input and output module configurations with dual or triple processor modules. The processor modules operate in 1002D under no fault conditions, degrade to 1001D on the detection of the first fault in either module and fail-safe when there are faults on both modules.

Input modules operate in 1002D under non faulted conditions and 1001D on detection of the first fault in one module and fail-safe when there are faults on both modules.

For high demand applications the processor must be repaired within the MTTR assumed in the PFD calculations or SIL 3 safety instrumented functions must be shut down.



**WARNING:** For SIL 3 applications you must use a minimum of a dual processor configuration.

For de-energize to action operation one digital output module is sufficient for SIL 3 requirements. However, for energize to action operation, dual digital output modules are required.

The single output module operates in 1001D under no fault conditions and fail-safe when there are is a fault on the module. For energize to action operation, the output modules operate in 1002D under no fault conditions, degrade to 1001D on the detection of the first fault in either module and fail-safe when there are faults on both modules.

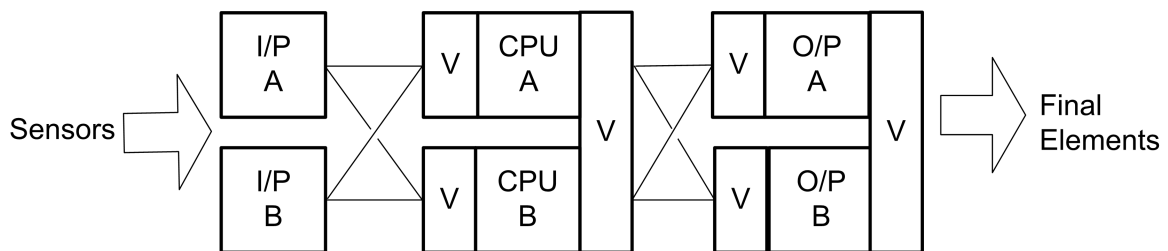

#### *Digital Output Modules*

A digital output module fault must be repaired within the MTTR which was used in the PFD calculation. This rule applies to simplex digital output modules in de-energize to trip applications and to dual digital output modules in energize to action applications.

#### *Analogue Output Modules*

An analogue output module fault must be repaired within the MTTR which was used in the PFD calculation. This rule applies to simplex analogue output modules where the safe state is less than or equal to 4 mA and to dual analogue output modules where the safe state is more than 4 mA.

**Table 10 - Modules for SIL 3 Fault Tolerant Architectures**

Position	Module Type
I/P A and I/P B	2 x T9401/2 Digital Input Module, 24 Vdc, 8/16 Channel + T9802 Digital Input TA, 16 Channel, Dual or 2 x T9431/2 Analogue Input Module, 8/16 Channel + T9832 Analogue Input TA, 16 Channel, Dual 2 x T9300 I/O Base Unit
CPU A & CPU B	2 x T9110 Processor Module, 9100 Processor Base Unit
O/P A and O/P B	1 x T9451 Digital Output Module, 24 Vdc, 8 Channel + T9851 Single Digital Output TA, 24 Vdc, 8 Channel for de-energize to action T9300 Base unit 2 x T9451 Digital Output Module, 24 Vdc, 8 Channel + T9852 Dual Digital Output TA for energize to action T9300 Base Unit Or 2 x T9481/T9842 Analogue Output Module, 3/8 Ch, Isolated + T9882 Analogue Output TA, 8 Ch, Dual T9300 Base Unit

**SIL 3 TMR Input and Processor, Fault Tolerant Output**

A SIL 3 TMR architecture offers the highest level of fault tolerance for an AADvance controller and consists of triple input modules, triple processors and dual output modules.

- The input and processor modules operate in a 2003D under no fault conditions, degrade to 1002D on detection of the first fault in any module, and degrade to 1001 on the detection of faults in any two modules and will fail-safe when there are faults on all three modules.

In the event of a failure in any element of a channel, the channel processor will still produce a valid output which could be voted on because of the coupling between the channels. This is why the triple modular redundant implementation supplies a configuration that is inherently better than a typical 2003 voting system.

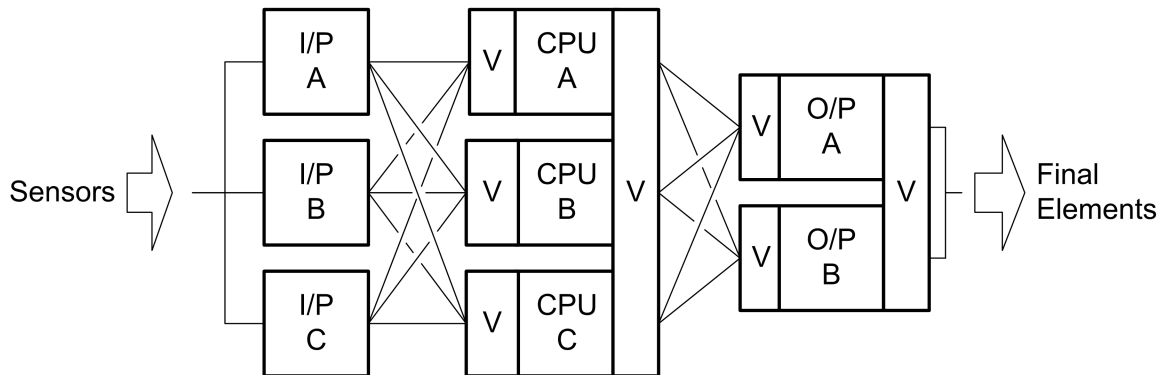

*Digital Output Modules*

A digital output module fault must be repaired within the MTTR which was used in the PFD calculation. This rule applies to simplex digital output modules in de-energize to trip applications and to dual digital output modules in energize to action applications.



### Analogue Output Modules

An analogue output module fault must be repaired within the MTTR which was used in the PFD calculation. This rule applies to simplex analogue output modules where the safe state is less than or equal to 4 mA and to dual analogue output modules where the safe state is more than 4 mA. (A 'safe state' is an output configured to go to a specific value, or configured to hold last state).

**Table 11 - Modules for TMR Input and Processor, Fault Tolerant Output**

Position	Module Type
I/P A	3 × T9401/2 Digital Input Module, 24 Vdc, 8/16 Channel + T9803 Digital Input TA, 16 Channel, TMR or 3 × T9431/2 Analogue Input Module, 8/16 Channel + T9833 Analogue Input TA, 16 Channel, TMR 2 × T9300 I/O Base Unit
CPU A & CPU B	3 × T9110 Processor Module, T9100 Processor Base Unit
O/P A	2 × T9451 Digital Output Module, 24 Vdc, 8 Channel + 9852 Digital Output TA, 24 Vdc 8 Channel, Dual; 1 × T9300 Base Unit Or 2 × T9481/T9842 Analogue Output Module, 3/8 Ch, Isolated + T9882 Analogue Output TA, 8 Ch, Dual; 1 × T9300 Base Unit

**NOTE** All configurations that use dual or triplicate processor modules are applicable for SIL 3 architectures with de-energize to trip outputs. Dual outputs are always required for SIL 3 energize to action outputs.

## Certified Configurations

Revisions of modules are subject to change. A list of the released versions can be obtained from Rockwell Automation.

**Table 12 - Central Modules**

Modules	Certified Configuration	Conditions
<b>Processor Module</b> T9110	1oo2D, 2oo3D	Safety-related and can be used for safety-critical applications in SIL 2 with 2 modules fitted and SIL 3 applications with 2 or 3 modules fitted. <b>Note:</b> For both Low and High Demand applications you must use a minimum of two processors.

### Input Modules

**Table 13 - Input Modules**

Modules	Certified Configuration	Conditions
<b>Digital Inputs</b> T9401/2, 24 Vdc, 8/16 Channel, isolated. + T9801/2/3 Digital Input TA, 16 channel, Simplex/Dual/TMR	1oo1D, 1oo2D, 2oo3D	De-energized to action (normally energized): SIL 3 with 1, 2 or 3 modules fitted. Energize to action (normally de-energized): with 1, 2 or 3 modules fitted <b>Note:</b> When the integrity level is at 1oo1D then the faulty module must be replaced to restore the integrity level back to 1oo2D.
<b>Analogue Inputs</b> T9431/2, 8/16 Channel, isolated + T9831/2/3 Analogue Input TA, 16 Channel, Simplex/Dual/TMR	1oo1D, 1oo2D, 2oo3D	Within the manufactures specified safety accuracy limits of 1%. The safety state of the analogue input has to be set to a safe value which is a calculated value based on a count value of 0 mA. (refer to the AADvance Configuration Guide Doc Nos: ICSTT-RM405 and ICSTT-RM458 for more details) SIL 3 with 1, 2 or 3 modules fitted. <b>Note:</b> When the integrity level is at 1oo1D then the faulty module must be replaced within the MTTR assumed for the PFD calculations to restore the integrity level back to 1oo2D.

**Table 14 - Output Modules**

Modules	Certified Configuration	Conditions
<b>Digital Outputs</b> T8451, 24 Vdc, 8 channel + T9851/2 TA, 24 Vdc, 8 Channel, Simplex/Dual	1oo1, 1oo2 or 1oo2D	De-energize to action (normally energized): SIL 3 with 1 or 2 modules fitted. (1oo2D with dual output modules fitted). Energize to action (normally de-energized): SIL 2 with 1 module fitted and SIL 3 with 2 modules fitted. A faulty digital output module must be repaired or replaced within the MTTR which was used in the PFD calculation. This rule applies to all simplex digital output modules and to dual digital output modules in energize to action applications.
<b>Analogue Outputs</b> T9481/T9842 Analogue Output Module, 3/8 Ch, Isolated + T9881/T9882, TA, 8Ch, Simplex/Dual	1oo1, 1oo2 or 1oo2D	SIL 3 with 1 or 2 modules fitted where the safe state is less than or equal to 4 mA SIL 3 with 2 modules fitted where the safe state is more than 4 mA (1oo2D with dual output modules fitted). A faulty analogue output module must be repaired or replaced within the MTTR which was used in the PFD calculation. This rule applies to all simplex analogue output modules and to dual analogue output modules where the safe state is > 4 mA

**Table 15 - Auxiliary Modules**

Modules	Conditions
<b>Processor Base</b> T9100	Safety-related and can be used for safety critical applications in SIL 2 applications with 2 modules fitted or SIL 3 applications with 2 or 3 modules fitted
<b>I/O Base</b> T9300 (3-way)	Safety-related and can be used for safety critical applications in SIL 3.

## Example Architectures with Approved Modules

The controller supports a range of architectures as defined in the previous chapter. This chapter describes how to assemble a range of architectures configurations and includes selected examples that illustrate the alternative options. The modular construction of the controller makes it easy to create module arrangements and these can be tailored for a specific application.

### Standard Architectures

The standard AADvance modules can be arranged to supply two fundamental architectures based on dual and triple modular redundant processors modules. To these can be added I/O modules for redundant and/or fault tolerant configurations based on the following arrangements:

- Input modules in simplex, dual and triple modular redundant formations

Figure 10 - Example Simplex SIL 2 System

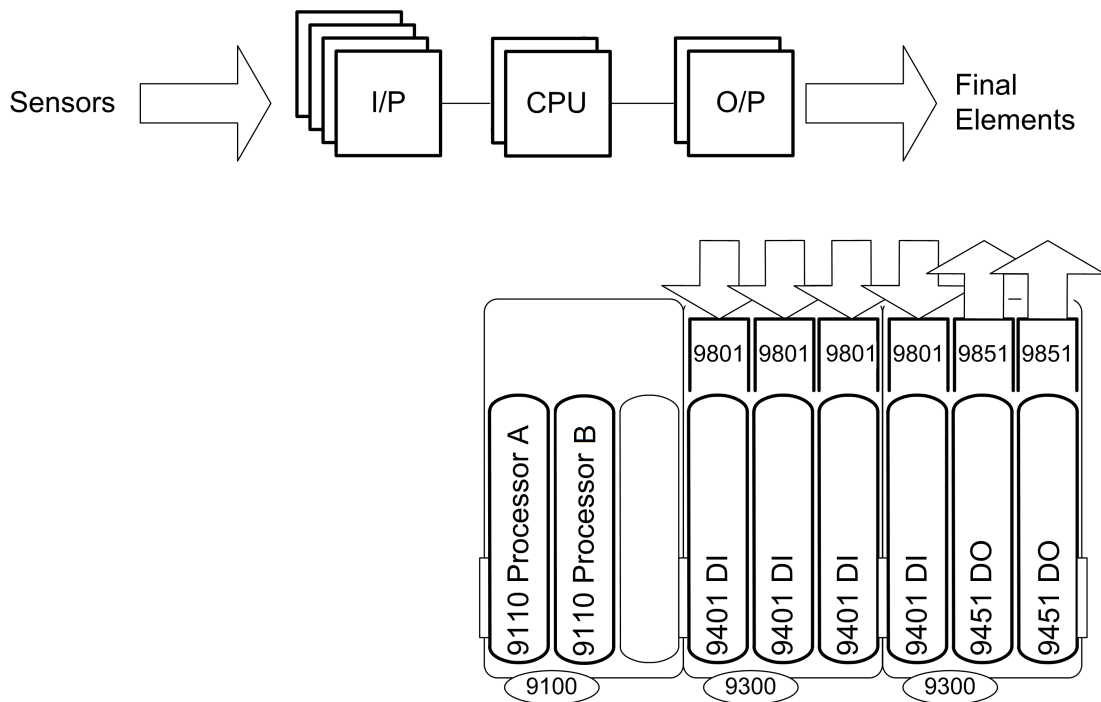

- Output modules in simplex and/or dual arrangements

Figure 11 - Example SIL 3 with Dual Input and Output Modules

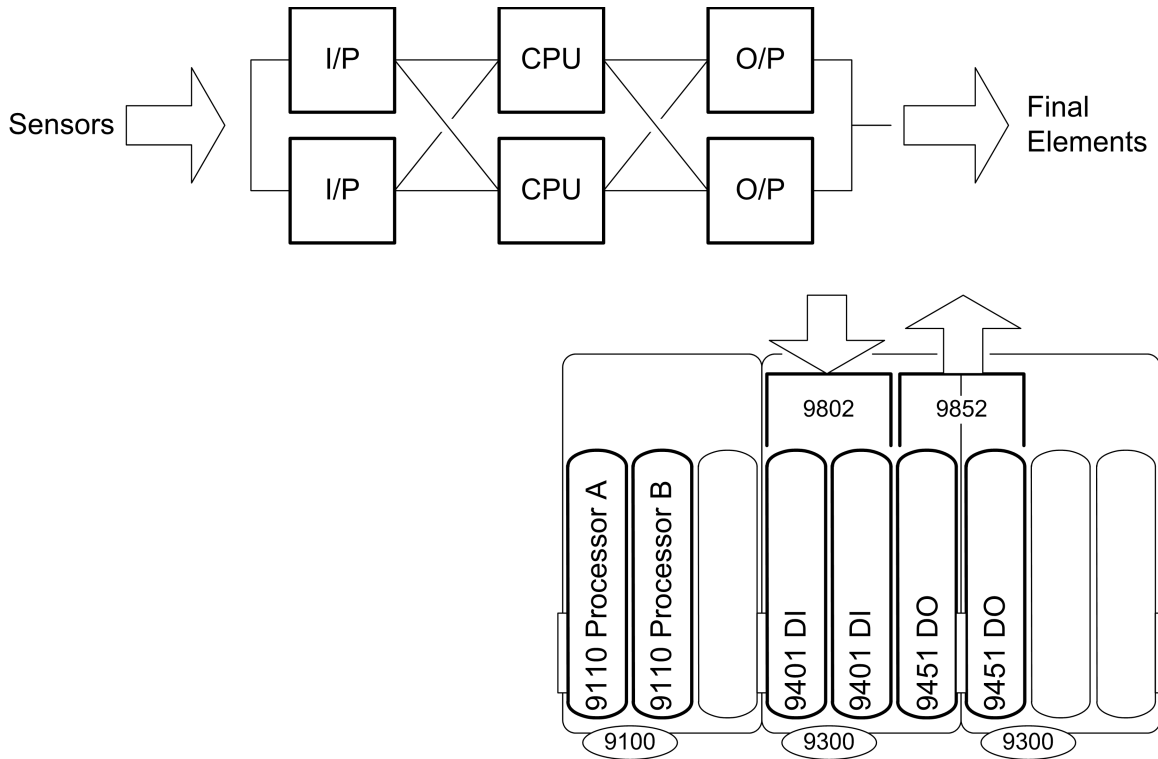

An AADvance system can mix different I/O architectures within one controller — for example simplex and dual input modules with dual processor modules. The modular construction of the controller enables you to create numerous other arrangements that can be tailored for a particular application.

Once a system has been built and commissioned it can be expanded using additional modules from the range to create many different architectures and meet specific additional safety and fault tolerant business requirements.

### Simplex I/O Architecture

A simplex configuration uses one input module for a field input, one output module for a field output, and two processor modules. Each input and output module will fail safe on the first detected fail danger fault and the process under control will shut down. The processor operates in 1002D under no fault conditions, will degrade to 1001D on the first fault in either processor module and will fail-safe when there are faults on both processor modules.

#### *Low Demand SIL 2 Architecture*

This is an example of a SIL 2 controller which is suited to low demand mode applications with de-energize and energize to action outputs. The T9801 and T9851 illustrated are the related simplex termination assemblies that mate with the T9401 and T9451 I/O modules. This arrangement is also applicable for non-safety applications.

Figure 12 - Low Demand SIL 2 Architecture System

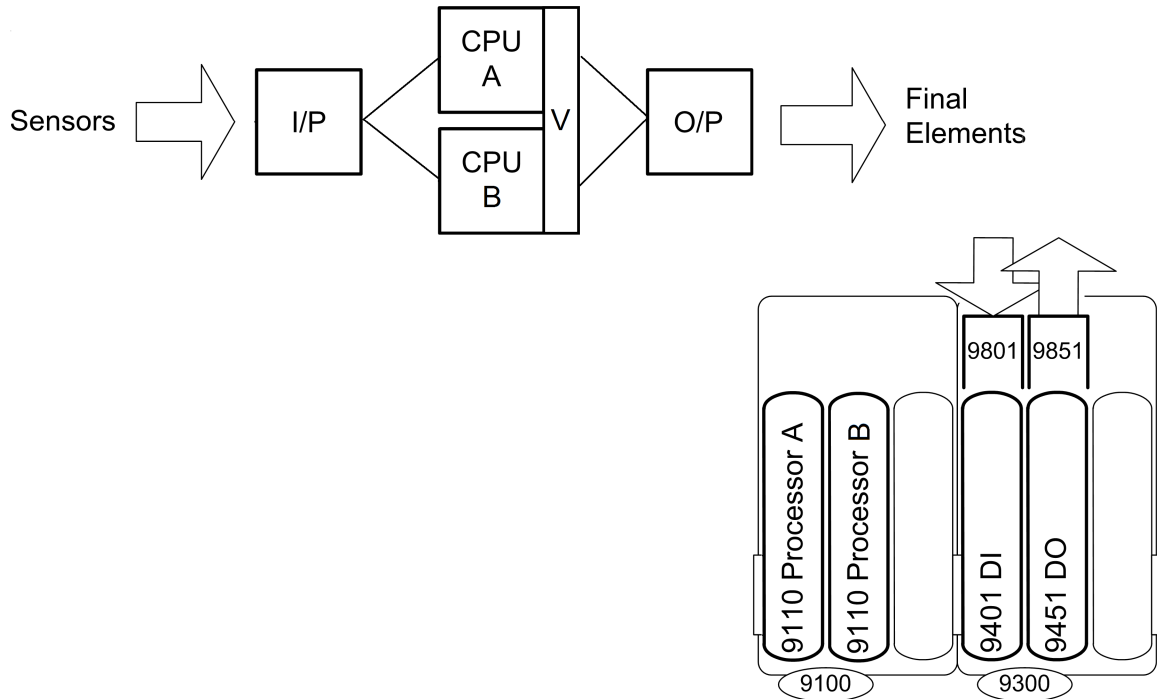

This example supports 8 field inputs and 8 outputs. There is space for one more processor module and one more I/O module. To expand the I/O capacity you have to add I/O base units then the required number of I/O modules and termination assemblies.

#### *Data Input and Output*

A controller can support up to 48 I/O modules in total (on 16 I/O base units); as an example, here is a controller with four 8 channel T9401 digital input modules and two 8 channel T9451 Digital Output Modules, giving 32 inputs and 16 outputs.

Figure 13 - Data Input and Output System

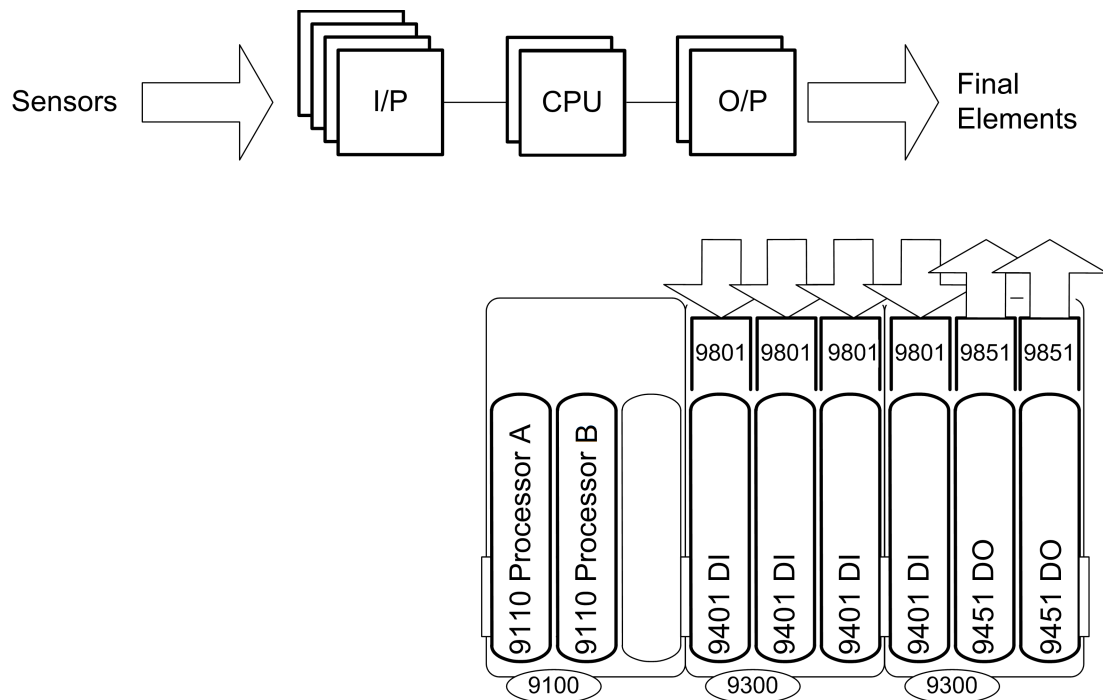

Two or three processor modules in a redundant arrangement are rated SIL 3, however, a minimum of two processor modules in a redundant arrangement are still required for architectures designed to meet SIL 2.

The T9401/2 digital input module (the same as the module for the SIL 2 controller) is rated SIL 3 as it stands. The only constraint is that the simplex output stage will not drive an energize to action output for SIL 3 - this requires a dual arrangement of output modules. This output configuration is applicable for a de-energize to action output at SIL 3.

The second processor module supplies the increased fault tolerance and gives the configuration its SIL 3 rating. If either processor module fails, the module must be replaced in the MTTR.

This controller suits many applications needing a mixture of SIL 3 de-energize to action and SIL 2 outputs which do not need the additional fault tolerance offered by dual and triple modular redundant configurations. The possibilities for expansion are the same as those for the SIL 2 controller.



Figure 14 - Dual Processor System

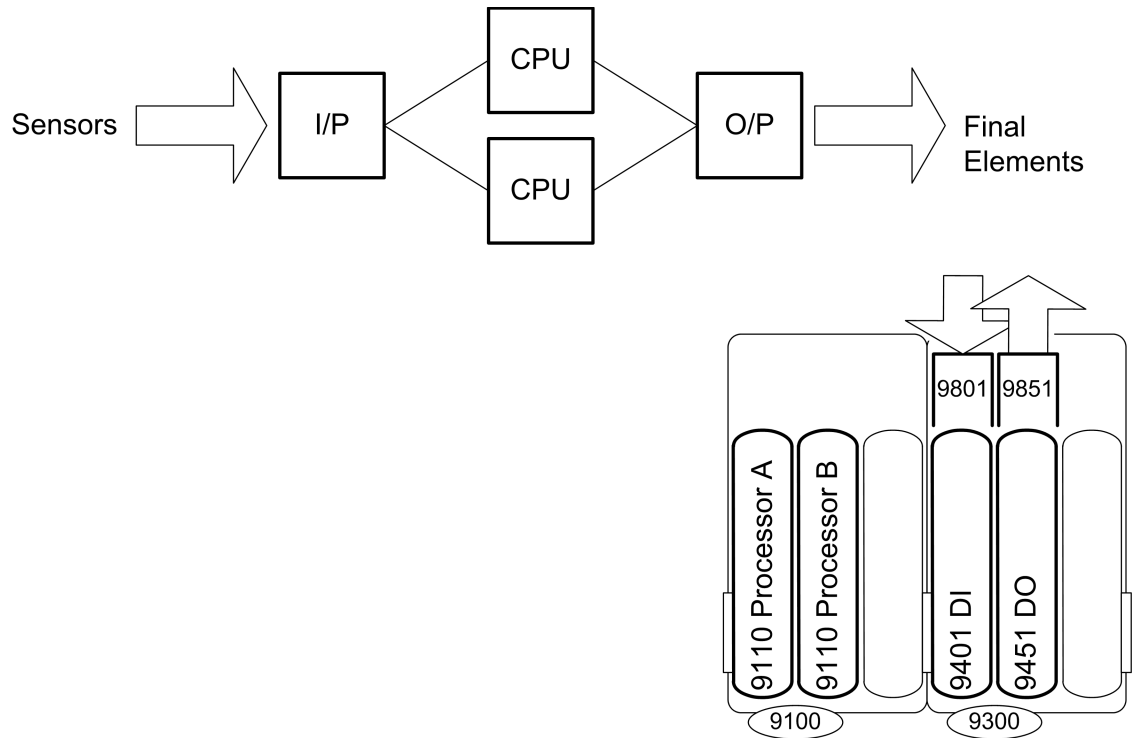

## Dual Architecture for Fault Tolerant Applications

### *Fault Tolerant Input and SIL 3 Outputs*

A dual architecture configuration shown uses two dual redundant modules for each stage. The use of two processor modules supplies SIL 3 integrity for the processor stage (as for the previous example) while the second input module supplies fault tolerance for the inputs.

A SIL 3 fault tolerant processor and I/O is achieved by dual input and output module configurations with dual or triple processor modules.

Figure 15 - Dual Inputs, Processor and Output System

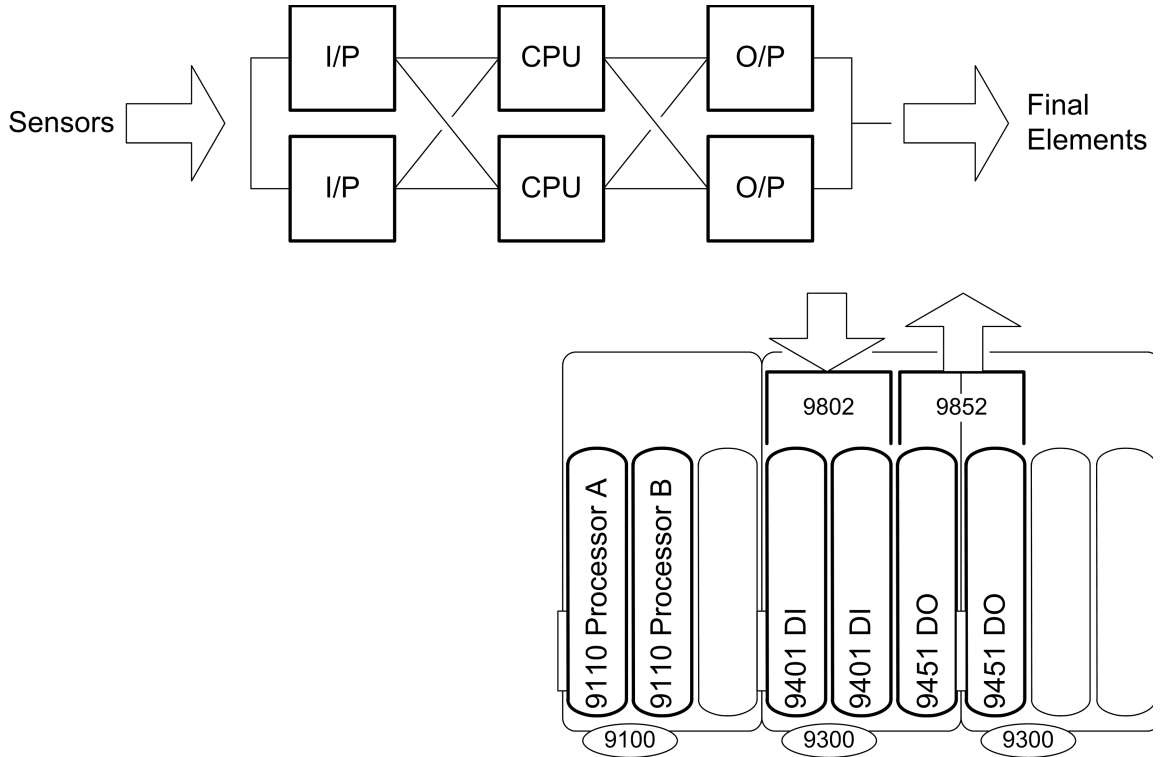

*Increasing I/O Capacity*

The capacity of this controller is increased by adding pairs of I/O modules and related dual termination assemblies. The subsequent example shows how to supply 16 inputs and 16 outputs (this could also be 32 inputs if 16 channel input modules are used). The outputs shown are digital output modules.

Figure 16 - Increased I/O System

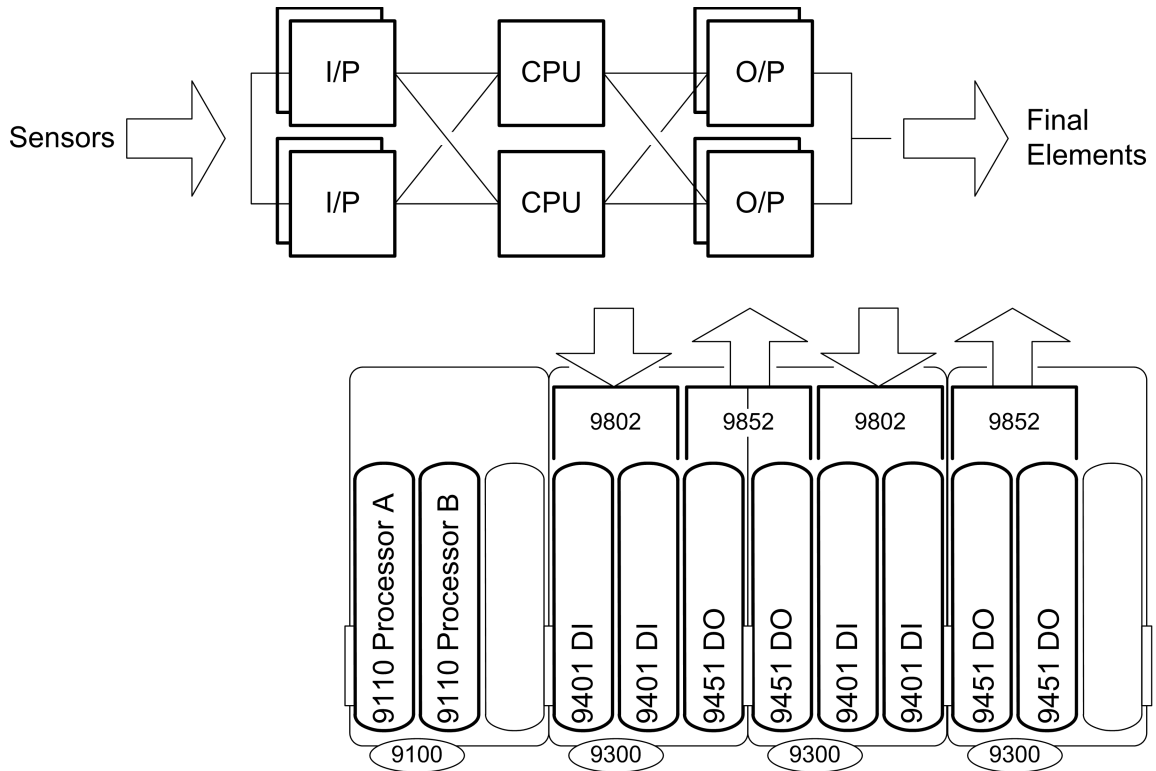

The T9852 dual termination assembly can be used with both 8 channel and 16 channel input modules.

### Triple Modular Redundant Architecture

A SIL 3 TMR architecture offers the highest level of fault tolerance for an AADvance controller and consists of triple input modules, triple processors and dual output modules.

If a failure occurs in an element of a channel, the channel processor will still supply a satisfactory output which could be voted on because of the coupling between the channels. This is why the triple modular redundant implementation has a configuration that is inherently better than a typical 2003 voting system.

Figure 17 - Triple Modular Redundant System

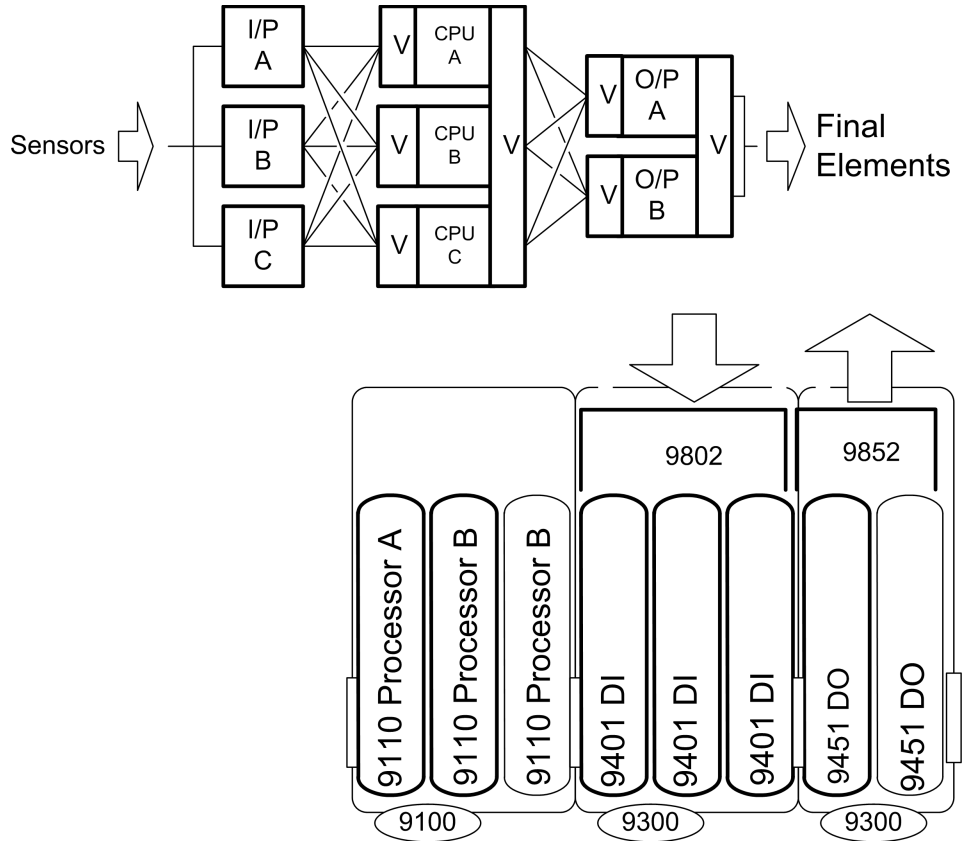

**IMPORTANT** All configurations that use dual or triplicate processor modules are applicable for SIL 3 architectures with de-energize to action outputs. Dual output modules are required for SIL 3 energize to action outputs.

You can add more groups of three input modules and pairs of output modules to increase I/O capacity. For example, a triple modular redundant controller using 8-channel modules for 16 inputs and 16 outputs could be arranged like this. For 16 channel TMR input you must use the T9402 16 channel digital input modules in the same arrangement.

Figure 18 - Increasing I/O capacity with an Expansion Cable

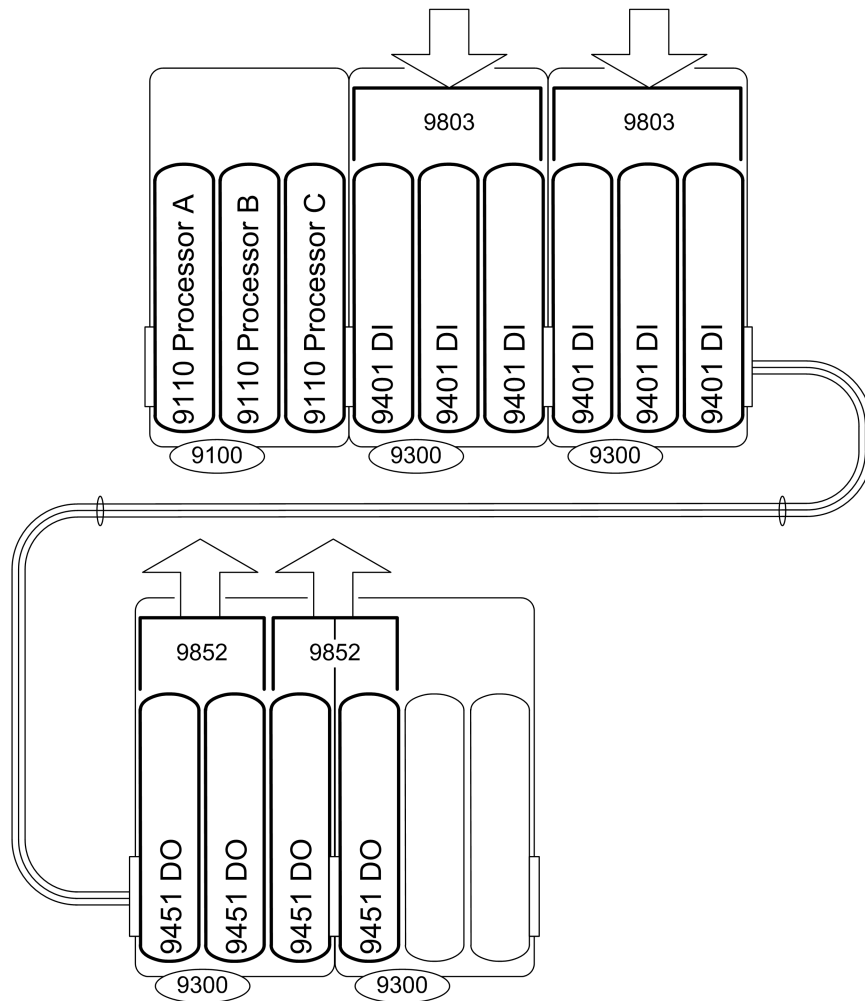

### Using an Expansion Cable

In the example a T9310 expansion cable assembly is used to connect the right-hand I/O base unit to another I/O base unit and modules.

## Mixed Architectures

It is straightforward to make dual and triple I/O controller architectures. A system can have a mixed level of redundancy, fault tolerance and safety integrity levels to meet your business application needs without over-specifying the I/O.

### Mixed I/O Architectures

An application could readily justify dual I/O for some field circuits, but not for all. It is easy and economical to configure one controller to offer a solution to cover both options. Consider a dual processor system that needs 16 inputs and 16 outputs, half of which must be duplicated and half of which can be simplex. This can be fulfilled by controller architecture like this.

Figure 19 - Mixed I/O System Equation

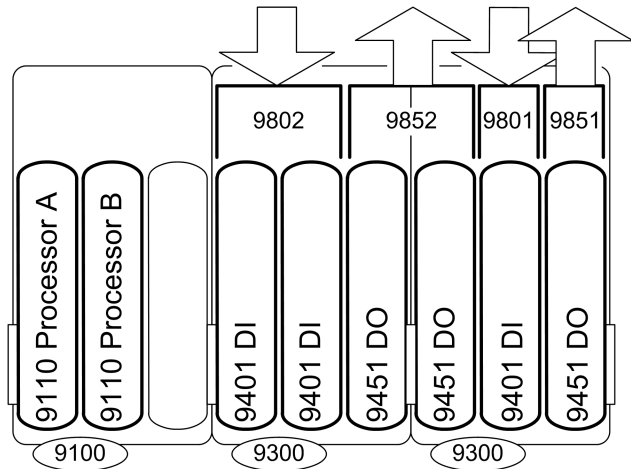
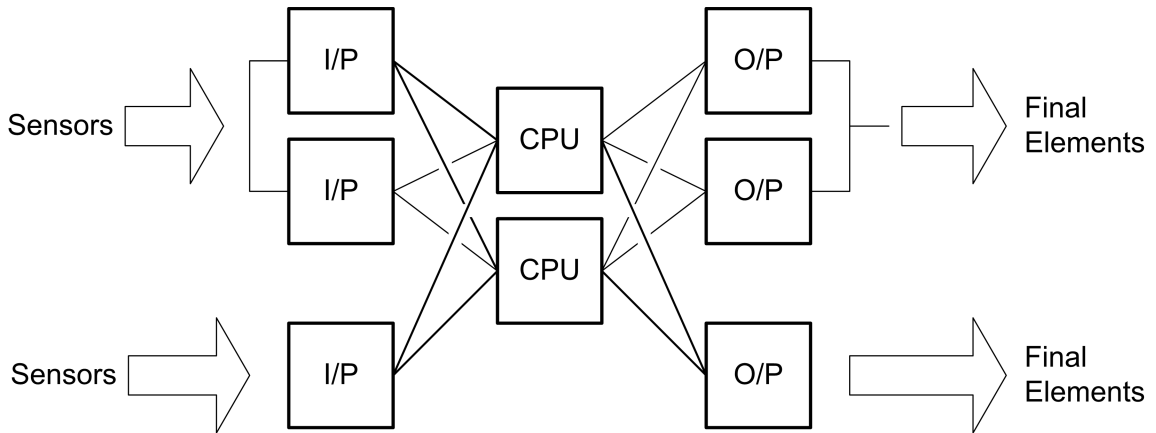

### Mixed Safety Integrity Levels

Such is the flexibility of AADvance that a single controller can support mixed safety integrity levels, for example, if a system needs SIL 3 energize to trip outputs alongside SIL 2 outputs.

The following example shows how a small viable controller for mixed integrity levels can be when built from AADvance modules. There are 16 inputs (or 32), two duplicated 8 channel inputs (or duplicated 16 channel versions), and two groups of 8 outputs (one dual, one simplex) for field devices.



Figure 20 - Mixed Safety System

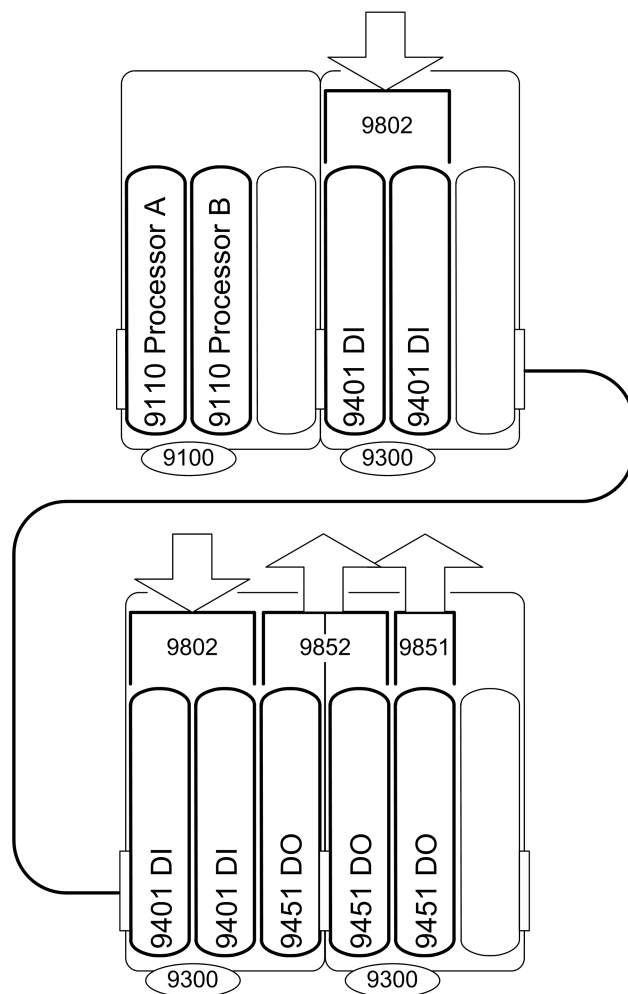
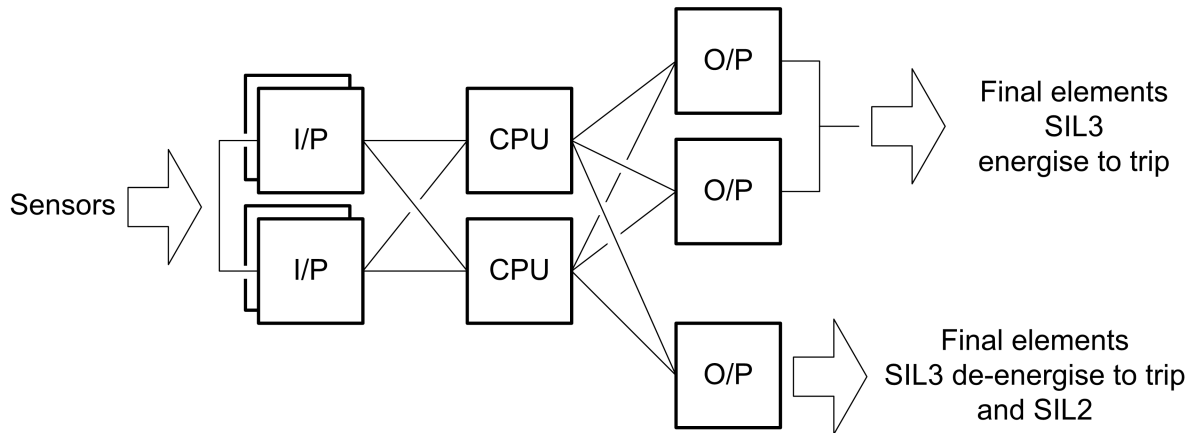

### Distributed Architectures

AADvance is designed to support a distributed safety architecture. Using an SNCP network a SIL 3 architecture can be maintained across multiple controllers by sharing safety data over an Ethernet network shown in the example below:

Figure 21 - Distributed Safety Architecture

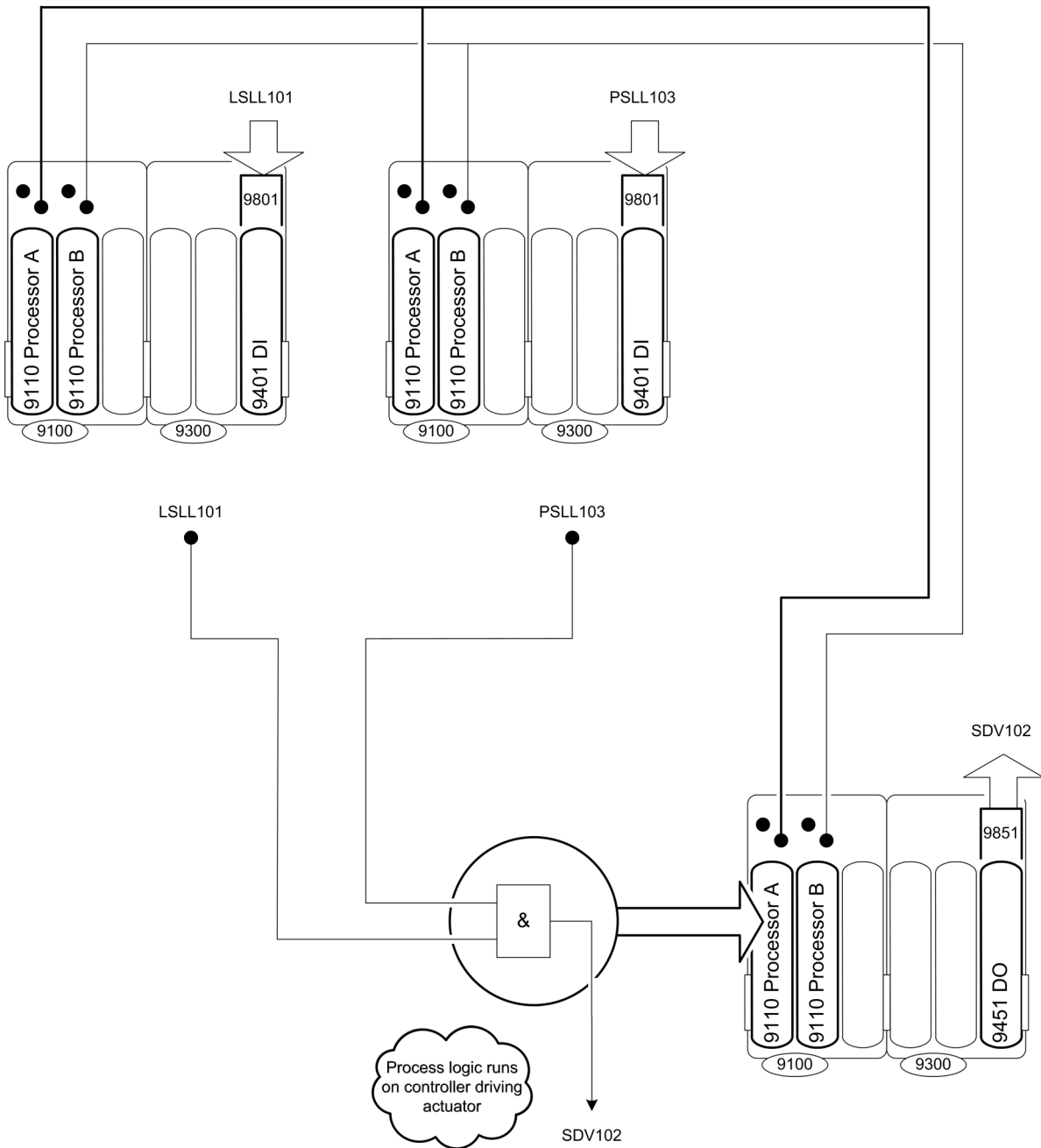

### Example Distributed Controller Systems

The following example shows a process protected by one distributed AADvance system. It uses an 8000 Series Trusted controller to handle bulk I/O, and four AADvance controllers for other parts of the plant.

Controllers 1 and 2 show two similar controllers which are almost the same applied to the same, duplicated areas of plant. The duplication of plant

(represented by the two compressors K1 and K2) in this system allows controllers 1 and 2 to be fail safe designs.

The parts of the plant managed by Controllers 3 and 5 are assumed (for the sake of this illustration) to need safety instrumented systems certified to a mixture of SIL 2 and SIL 3. Controller 3 exploits the flexibility of the AADvance system to supply mixed SILs in one controller.

Controller 4 manages the fire and gas system in the plant. The example uses an 8000 Series Trusted® controller here in a role which uses a large quantity of field devices. The 8000 Series Trusted controller is fully integrated into the system and shares the applications with the AADvance controllers.

**Figure 22 - Distributed System**

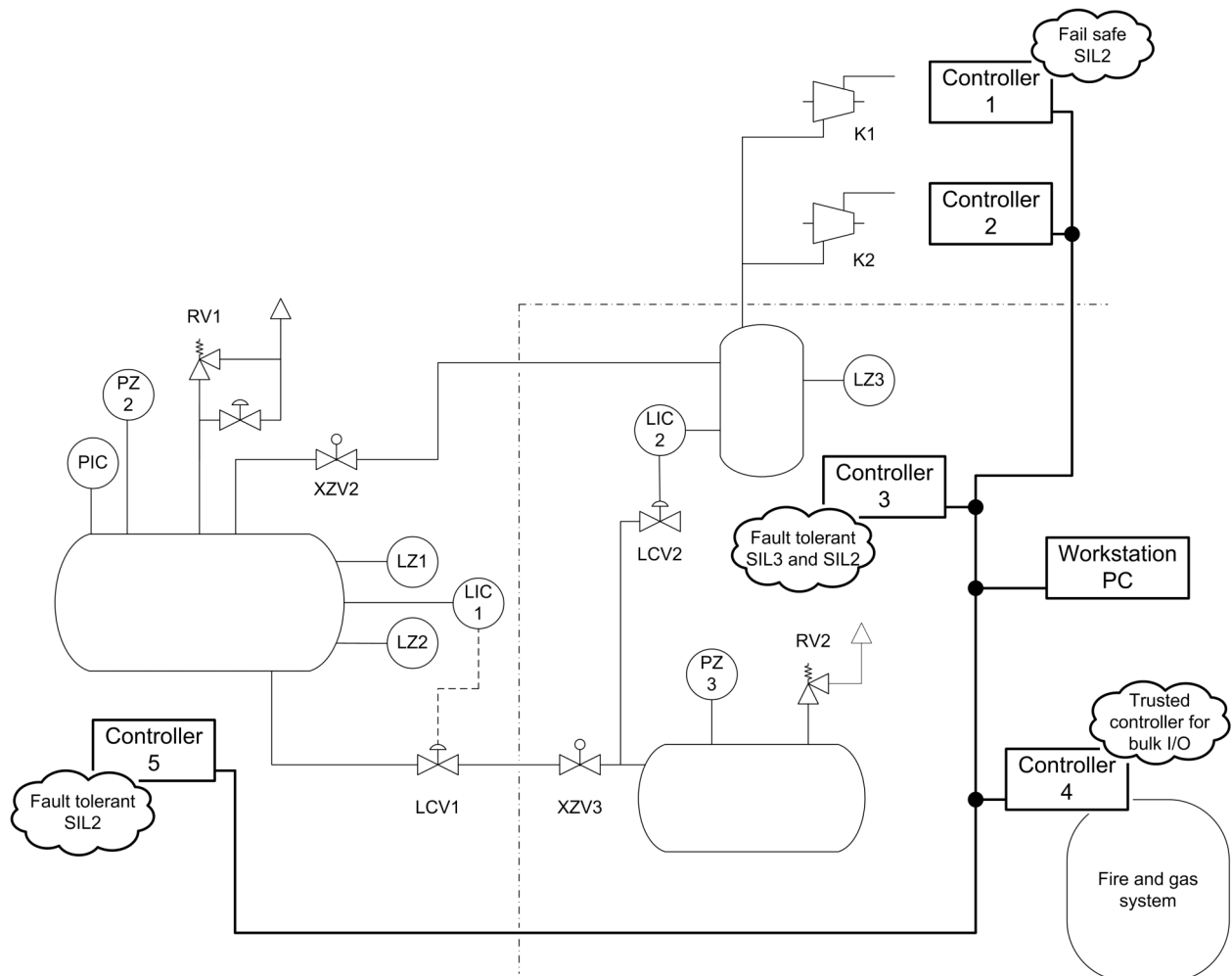

## Typical Network Applications

A usual distributed AADvance system uses two networks:

- An information network, which supplies connectivity to the BPCS (basic process control system) and to OPC devices

- A dedicated safety network, which handles data shared between the AADvance controllers

Figure 23 - Distributed Network System

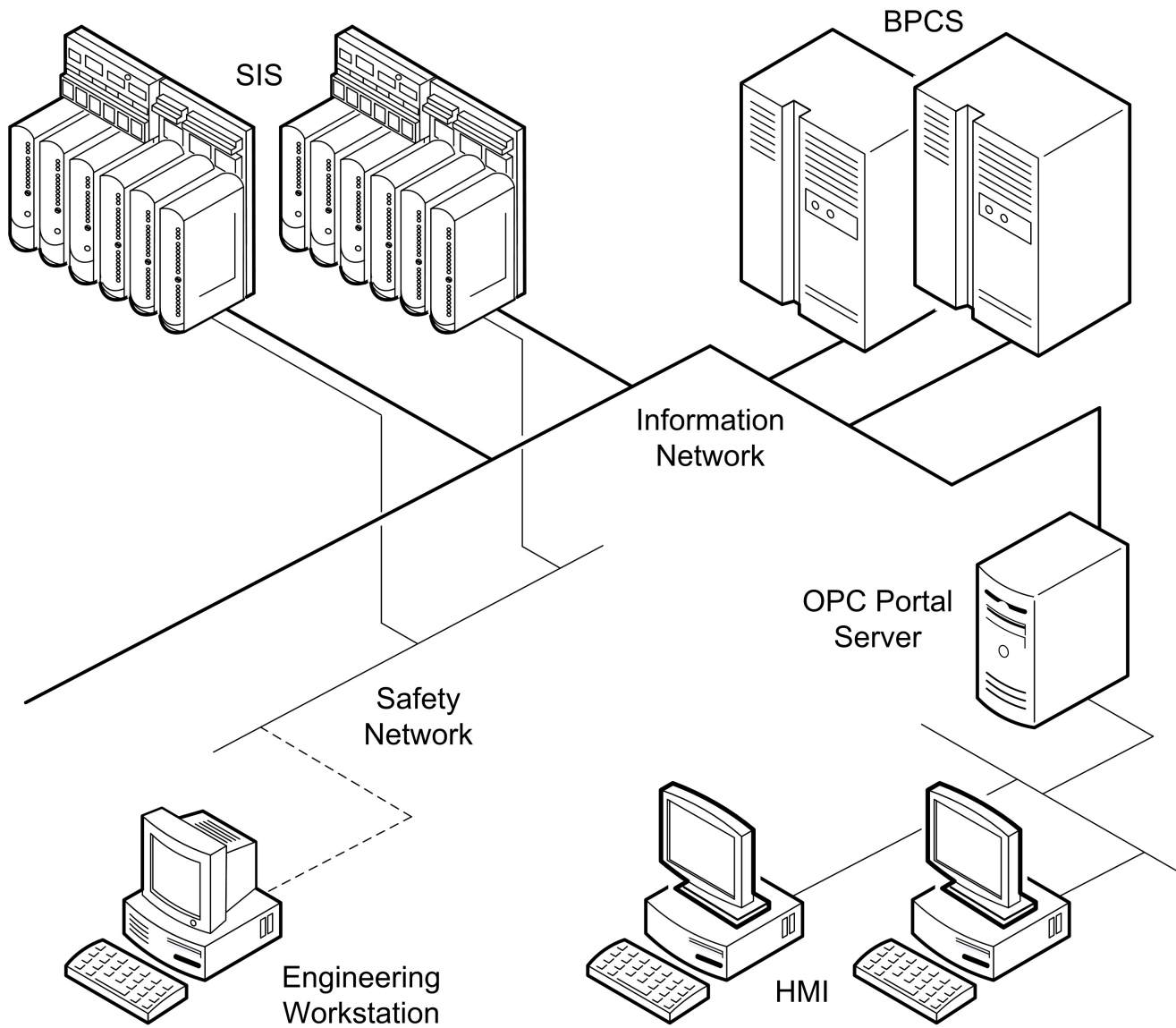

The engineering workstation could connect to the safety network (as illustrated), to the data network or to the two networks.

As drawn, the OPC portal server collects data from the controllers and displays it on the HMIs and, conversely, delivers commands from the HMIs to the controllers. The data network carries real time data (MODBUS TCP) from the BPCS to the controllers.

### Controller External Network Connectors

The controller features six auto-sensing 10/100BASE-TX Ethernet ports which let it to connect to a local area network through standard RJ45 Ethernet cable. There are two ports for each processor module.

The controller Ethernet ports are found on the T9110 processor base unit and identified like this:

**Table 16 - Allocation of 10/100BASE-TX Ports to Processor Modules**

<b>10/100BASE-TX Ports</b>	<b>T9110 Processor Module</b>
E1-1, E1-2	Processor A
E2-1, E2-2	Processor B (if fitted)
E3-1, E3-2	Processor C (if fitted)

## Specifying a Safety Network

Once a system uses distributed controllers with shared data, the topology of the safety network must be robust. To do this, make sure the network has no single point of failure, refer to the AADvance Safety Manual (Document: ICSTT-RM446) for further details about specifying a safety Network.

**Notes:**

## AADvance Scalability

The AADvance® design concept gives an expandable solution for each application through its current range of I/O modules and termination assemblies. Increased I/O capacity is possible because it is easy to add new modules and it gives you the flexibility to create different architectures by changing the I/O capacity and arrangement.

### I/O Channel Capacity

When creating a system, AADvance offers horizontal scalability. The maximum I/O channel capacity of a single controller depends on if you assemble I/O modules in simplex, dual or triple modular redundant configurations.

You increase the I/O capacity of a controller by adding I/O base units, termination assemblies and I/O modules. You can also use 16 channel modules on a termination assembly and thus increase the I/O channel capacity per module. An expansion cable allows you to use the controller second I/O bus (I/O Bus 2) and add up to 24 I/O modules giving a total of 48 I/O modules per controller.

An AADvance system also supports and integrates fully with existing MODBUS subsystems and, through its own server, supplies interoperability with HMIs and other OPC devices.

### Simplex I/O Channel Capacity

When you need I/O modules arranged in simplex configurations you must use the simplex termination assembly for each module type. You can use a physical arrangement of 8-channel and 16-channel input modules with their simplex termination assemblies, also any arrangement of output modules with simplex termination assemblies. For example, you can put all digital inputs together in a rack and all analogue inputs together, or mix them together.

The maximum number of simplex I/O channels is limited only by the selection of modules. For example, 16 x 16 Channel input modules and 32 x 8 Channel output modules, equals a maximum of 512 channels.

Figure 24 - Simplex I/O Modules

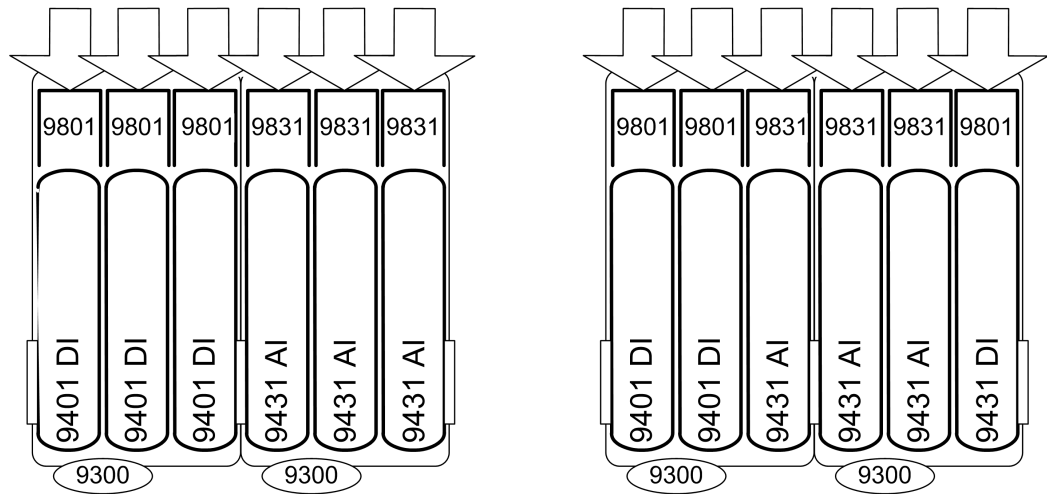



## Dual I/O Channel Capacity

When you need I/O modules arranged in dual redundant formations, each pair of modules shares a dual termination assembly and occupies two-thirds of an I/O base unit. The termination assemblies can bridge adjacent I/O base units, so two base units will hold three pairs of dual redundant module configurations, while three base units will hold four pairs. Arrange base units in groups of two or four to optimize capacity for dual redundant modules.

If you assemble base units in groups of two or four, a single controller supports 24 pairs of I/O modules. The capacity using for example eight pairs of 16-channel input modules and sixteen pairs of output modules is 256 I/O channels ( $8 \times 16 = 128$ ,  $16 \times 8 = 128$ ).

The capacity using 8-channel modules in dual configurations (24 pairs) is  $24 \times 8 = 192$  I/O channels. This can, for example, be 64 digital inputs, 64 analogue inputs and 64 digital outputs, or any combination of these values with a granularity of eight, the capacity of one I/O module.

Figure 25 - Dual I/O Modules

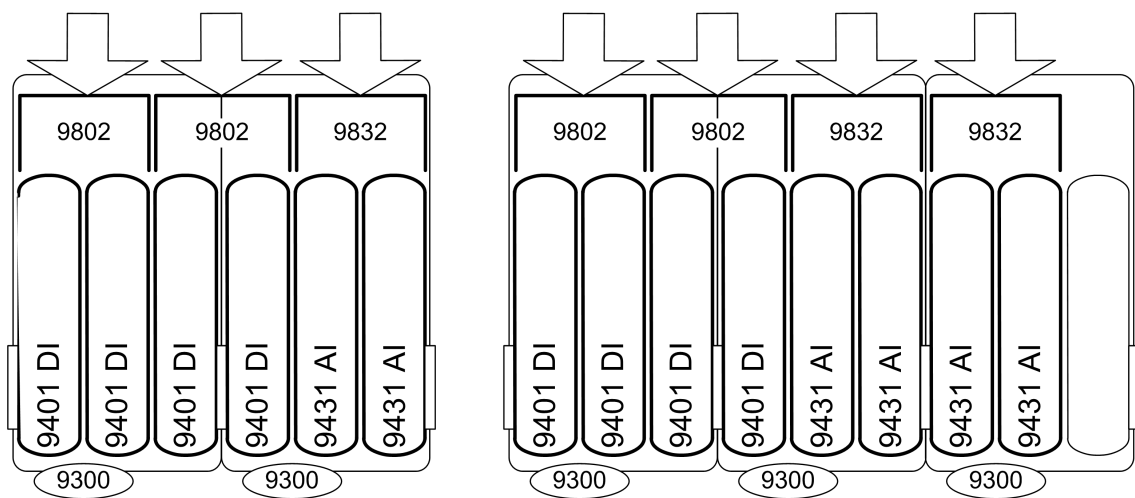

## Triple Modular Redundant Channel Capacity

When you need input modules arranged in triple modular redundant formations, each group of three modules will share a single triple termination assembly and occupies all of an I/O base unit. A single controller supports 16 groups of three modules, so a hypothetical controller using 16-channel input modules and needing no output channels will have a capacity of  $16 \times 16 = 256$  input channels.

A solution using 8-channel modules and needing dual output modules as well as triplicated input modules will, with a ratio of 2:1 of inputs to outputs, supply 96 input channels and 48 output channels. These capacities are derived like this:

### Input Channels

- 12 groups of three 8-channel input modules have 12 base units and yield  $12 \times 8 = 96$  input channels.

### Output Channels

- 6 pairs of output modules have the remaining 4 base units and yield  $6 \times 8 = 48$  output channels.

## Adding I/O Channel Capacity

You can identify a new controller to have the correct quantity of I/O channels that you need and also configure spare I/O channels that you anticipate you could need in the future. Having done this, it is straightforward to add more T9300 I/O base units and modules when you expand the controller.

However, if you haven't configured spare slots for new hardware you can still expand your system. You can install the new hardware and change the controller hardware configuration in the AADvance Workbench and load the changed application.

## On-line updates I/O Configuration Changes

The AADvance controller modular design makes it easy to create and change the I/O configuration. The on-line update facility enables you to make changes to the I/O configuration after the system is commissioned.

An on-line update can be used for the following changes.

- Expand a system and add new I/O modules, base units and termination assemblies.
- Change the module type in a simplex or group arrangement.
- Expand a simplex or group arrangement.
- Downgrade a group arrangement.
- Move a module to a different slot.
- Change an application variable.

You only have to plug an additional I/O base unit into the side socket on an installed I/O base unit. The command busses on the I/O base units do not need different terminations on the open ends of transmission lines, and the data response busses and power sources are supplied across all I/O base units. Termination assemblies are pushed into the I/O base unit for the additional I/O modules. To put the new modules on-line and make the changes to the system fully operational, the hardware configuration in the AADvance® Workbench software must be updated by an on-line update.

---

**IMPORTANT** For Release 1.3 you can change the I/O module configuration with an on-line update. However, if you are using an earlier product release the I/O configuration cannot be changed with an on-line update.

---



---

**IMPORTANT** An on-line update could affect the operation of the controller such that the application is stopped or the I/O data flow is interrupted. The AADvance Safety Manual outlines the precautions you need to follow when doing on-line updates on a Safety System.

---

When there is not sufficient space for extra I/O base units on a row you can use the Expansion Cable to connect a new row of I/O base units and modules to further expand the I/O system

## Bus Connectors and Expansion Cable

The T9100 processor base unit command and response busses and system power for I/O modules are output by the two connectors on each side of the base unit:

- The right-hand connector (specified I/O bus 1 in the project tree configuration) mates with a connector on the T9300 I/O base unit. I/O bus 1 supports a maximum of eight I/O base units and 24 I/O modules.
- The left-hand connector (specified I/O bus 2 in the project tree configuration), mates with the T9310-02 Backplane Expansion Cable, which will connect it to another T9300 I/O base unit. I/O Bus 2 supports a maximum of 8 I/O base units and has response lines for a maximum of 24 I/O modules.

The expansion cable carries module power, command busses and individual response busses for each I/O module.

**Figure 26 - Expansion Cables for I/O Bus 1 & 2**

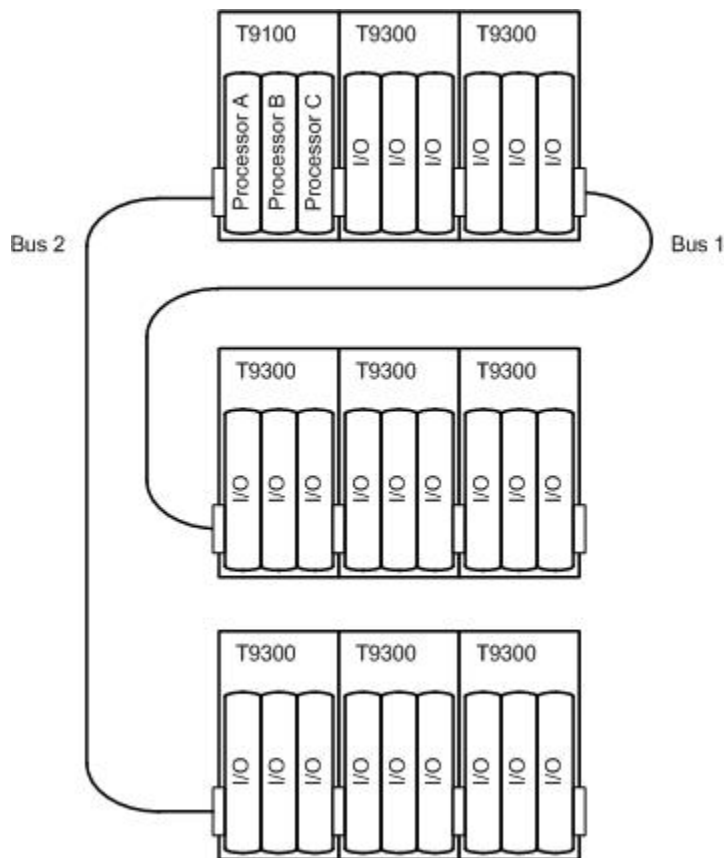

## Redundancy and Fault Tolerance

An important advantage of the AADvance design is the option to add redundant modules to increase fault tolerance as and when they are required. Redundant configurations let you replace faulty modules without affecting the system operation.

This flexibility and operational persistence is made possible by Termination Assemblies that supply redundant I/O module capacity. By installing a triple termination assembly you can configure the I/O and use it in a simplex, dual or triple redundant arrangement.

The AADvance controller, therefore, gives an economical solution for redundancy and fault tolerance expansion. You can install the termination assemblies and base units for increased capacity in the future, then add the extra I/O modules only when you actually need them.

## Expansion using Distributed Controllers

You can expand an AADvance system by adding more controllers to create a distributed system. The AADvance Discover (Discovery and Configuration utility) enables you to connect to external controllers.

---

**IMPORTANT** The recommended maximum size of a typical distributed AADvance system is 20 controllers.

---

**Notes:**

---

## Specifying a New Controller

This chapter goes through a list of key information needed to specify a new AADvance® controller. The flowcharts and tables that follow will guide you through the process of defining a system for your business application and system requirements.

### Information to Specify a New Controller

The following sets of information are needed to specify a new controller:

- The intended safety integrity level (SIL 2 or SIL 3) for your application
- The desirable degree of fault tolerance
- Whether any final elements are energize to action (affects output module arrangements for SIL 3 requirements)
- The type and quantity of inputs and outputs
- The process safety time for each safety function
- Do you need a "hot swap" feature for any channels

All of these items must be assessed and known for the specified plant and the intended application.

# Define a New System

The charts use minimal designs to illustrate solutions.

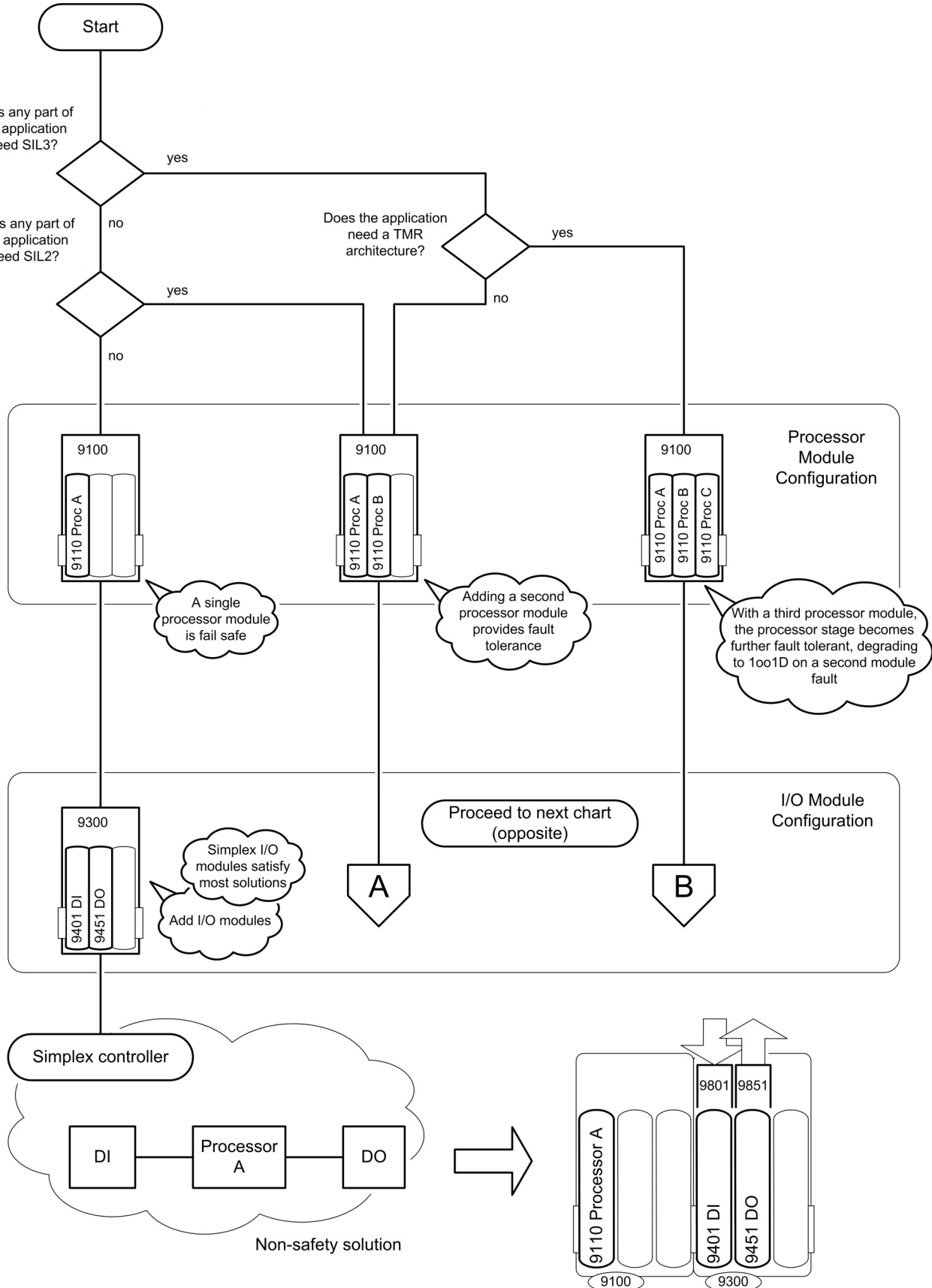



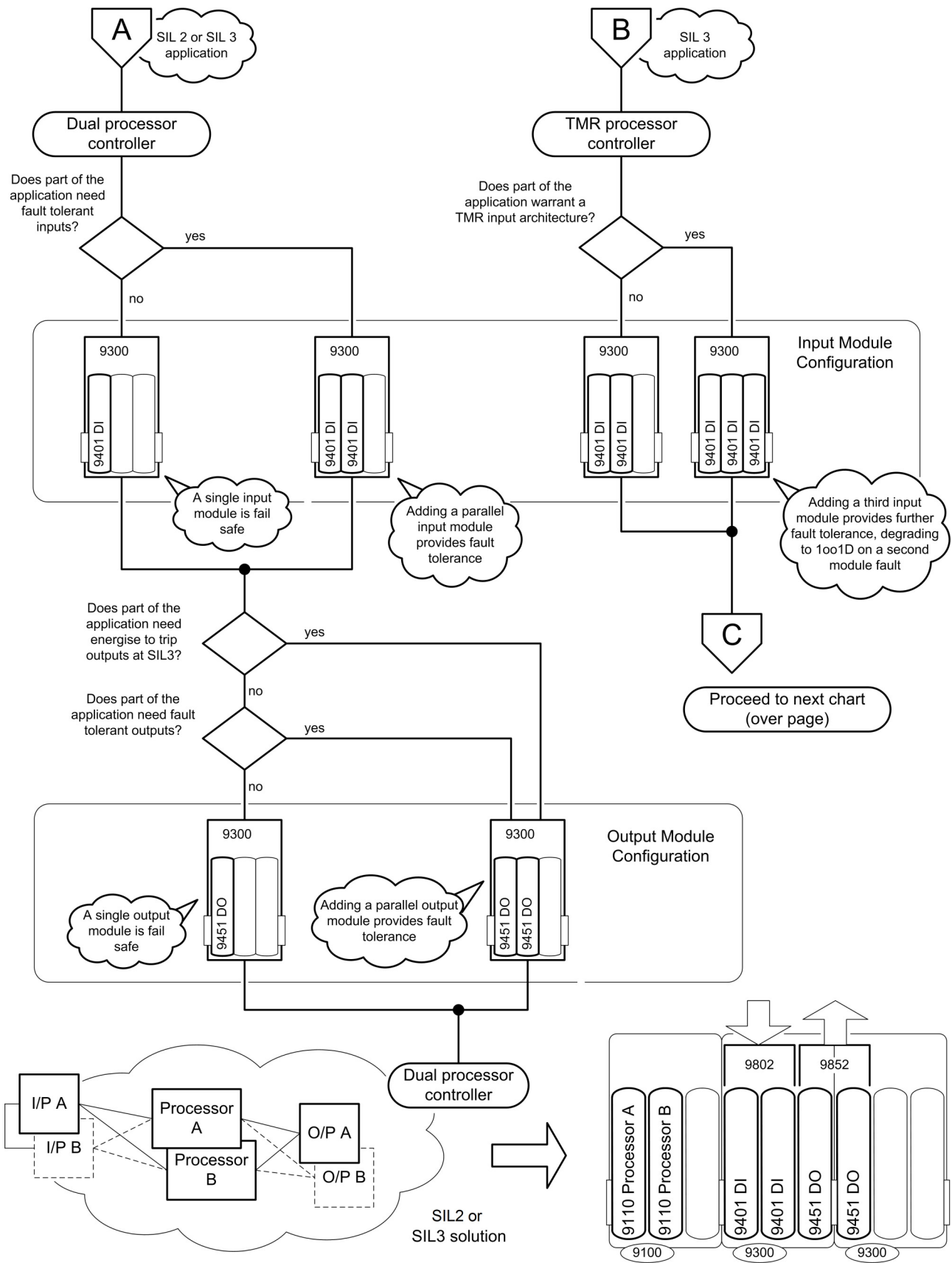

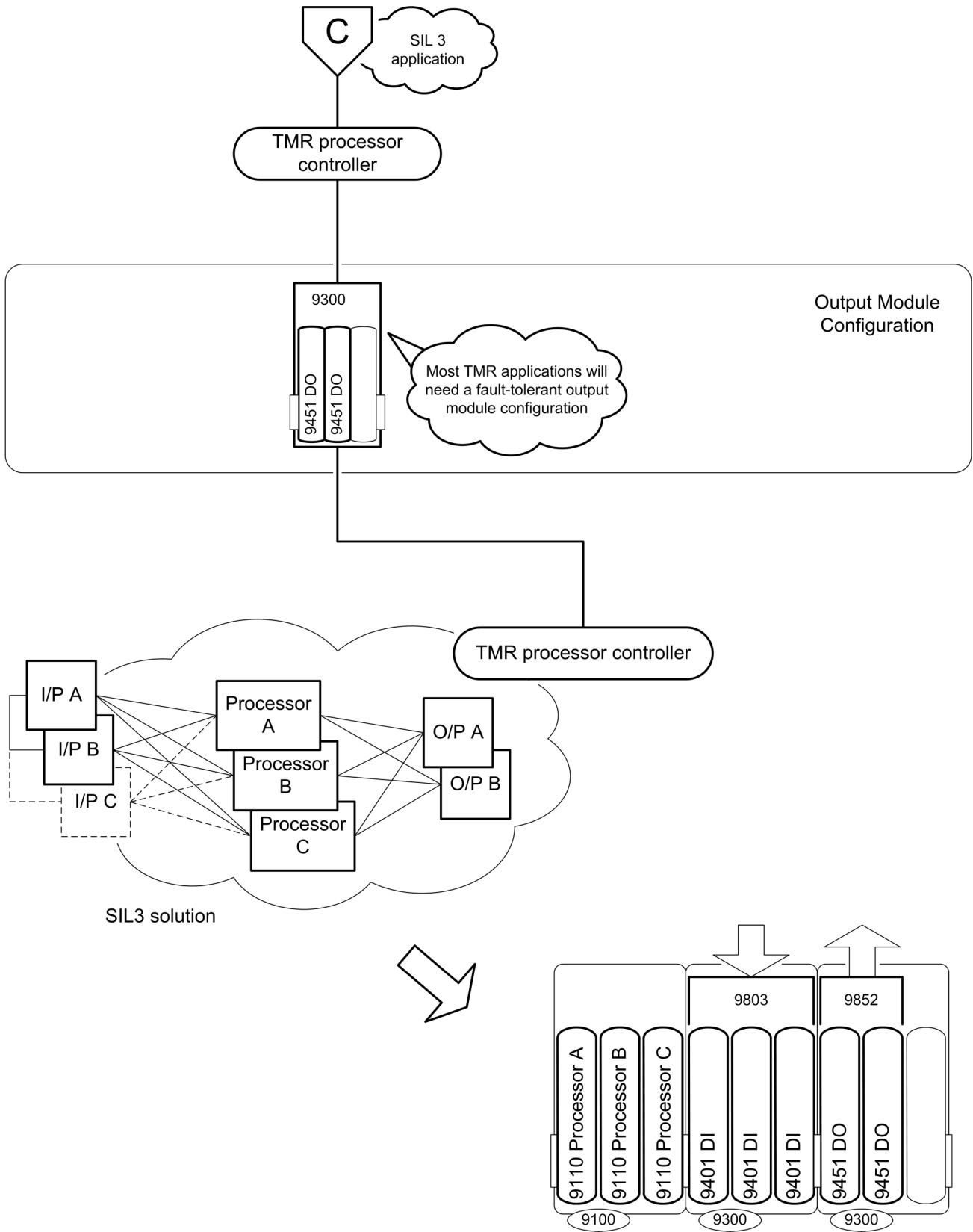

## Specify I/O Base Units

The T9300 I/O base unit (3 way) is a single, standardized design which suits all termination assemblies and I/O modules. The base unit can have one triple modular redundant assembly, one dual assembly and one simplex assembly or up to three to simplex assemblies. The dual and triple modular redundant assemblies can bridge adjacent base units, so two base units can (for example) hold three dual assemblies.

## Choosing Termination Assemblies

The use of termination assemblies gives the AADvance system flexibility for creating different architectures and expanding the system. Each termination assembly is a very simple circuit that is matched to a type of I/O module and to a specified module configuration. This table shows a summary of the termination assemblies which are available and the related I/O module configurations.

**Table 17 - Choosing a Termination Assembly**

	<b>Simplex I/O Module Configuration</b>	<b>Dual I/O Module Configuration</b>	<b>Triple I/O Module Configuration</b>
Digital input	T9801, Digital Input TA, 16 channel, Simplex Commoned (non-isolated)	T9802, Digital Input TA, 16 channel, Dual	T9803, Digital Input TA, 16 channel, Triple
Analogue input	T9831, Analogue Input TA, 16 channel, Simplex, commoned (non-isolated)	T9832, Analogue Input TA, 16 channel, Dual	T9833, Analogue Input TA, 16 channel, Triple
Digital output	T9851, Digital Output TA, 8 channel, Simplex, commoned (non-isolated)	T9852, Digital Output TA, 8 channel, Dual (non-isolated)	Not applicable
Analogue Output	T9881, Analogue Output TA, 8 Channel, Simplex, commoned	T9882, Analogue Output TA, 8 channel, Dual	Not applicable

**IMPORTANT** The termination assemblies for inputs have 8-channel I/O modules and 16-channel I/O modules. A dual or triple arrangement can be made of 8- or 16-channel modules, but not a mixture of the two.

You need one termination assembly for each group of related modules. For example:

- Four T9401 digital input modules used in two, dual redundant configurations need two T9802 termination assemblies — one for each pair of modules
- Four T9401 digital input modules used for simplex inputs need four T9801 termination assemblies — one for each module

## Estimate AADvance Controller Weight

Use the following table to make an estimate of the weight of your controller.

**Table 18 - AADvance Controller Module Weight**

Item	Number Used	Weight Allowance g (oz.)	Subtotal
T9100 Processor Base Unit		× 460 g (16 oz.)	
T9110 Processor Module		× 430 g (15 oz.)	
T9401 Digital input module, 24 Vdc, 8 channel		× 280 g (10 oz.)	
T9402 Digital input module, 24 Vdc, 16 channel		× 340 g (12 oz.)	
T9431 Analogue input module, 8 channel		× 280 g (10 oz.)	
T9432 Analogue input module, 16 channel		× 340 g (12 oz.)	
T9451 Digital output module, 24 Vdc, 8 channel		× 340 g (12 oz.)	
T9482 Analogue output module, 8 channel		× 290 g (10.5 oz.)	
T9300 I/O base unit (3 way)		× 133 g (5 oz.)	
T98x1 Simplex Termination assembly		× 133 g (5 oz.)	
T98x2 Dual Termination Assembly		× 260 g (10 oz.)	
T98x3 Triple Termination Assembly		× 360 g (13 oz.)	
T9310 Expansion cable assembly and 2 m cable		× 670 g (24 oz.)	
T9841 Termination Assemblies (average weight)		× 175 g (6 oz.)	
	Total estimated controller weight		

## System Installation Environment

The installation environment can be a source of common cause failure so it is necessary that the installation assessment covers the environmental specification for the AADvance system and includes the following:

- the prevailing climatic conditions
- type of area, e.g. is it a hazardous or non-hazardous area
- location of power sources
- earthing and EMC conditions

In some customer installations parts of the system can be installed in differing locations; in these cases the assessment must include each location.

### Power Sources and Heat Dissipation Calculations

It is highly recommended that module supply power and field loop power consumption calculations are done to find out the heat dissipation before designing a suitable enclosure and making a decision about the installation environment (see topic "System Design for Heat Dissipation").

### Safety Related System Installation Process

For a Safety Related System the installation process must also be in line with the following:



**WARNING:** You must use the installation guidelines given in this manual and any installation and commissioning procedures that comply with applicable international or local codes and standards.



**ATTENTION:** AADvance modules are suitable for use in Class I, Division 2, Groups A, B, C and D Hazardous locations or Non-hazardous locations only or equivalent.



**ATTENTION:** Pour les modules AADvance sont utilisables dans Class I, Division 2, A, B, C et D pour un environnement dangereux ou pour un environnement non dangereux ou équivalente

## Specifying an Enclosure

When the system is installed in an enclosure it must meet the UL508 requirements for the installation environment; hold the modules securely, provide mechanical protection and should not interfere with other system components. The enclosure must also be able to handle the heat dissipated by the modules and other components/devices included in the same enclosure.

### Maximum Enclosure Air temperature



**CAUTION: HEAT DISSIPATION AND ENCLOSURE POSITION**

The maximum air temperature rating in an enclosure where standard AADvance processor and I/O modules are installed to maintain predictable reliability is +70 °C (+158 °F) for I/O Modules and +60 °C (+140 °F) for Processor modules. System and field power consumption by modules and termination assemblies is dissipated as heat. You should consider this heat dissipation during the design and positioning of your enclosure; e.g. enclosures exposed to continuous sunlight will have a higher internal temperature that could affect the operating temperature of the modules. Modules operating at the extremes of the temperature band for a continuous period can have a reduced reliability.



**ATTENTION: DISSIPATION THERMIQUE ET EMPLACEMENT DE L'ENCEINTE**

La température ambiante nominale maximum dans une enceinte où un processeur AADvance et des modules d'E/S standard sont installés pour assurer une fiabilité prévisible, est de +70 °C (+158 °F) pour modules d'E/S et de +60 °C (+140 °F) pour un processeur modules. La consommation électrique du système et du terrain par les modules et les ensembles de raccordement est dissipée sous forme de chaleur. Vous devez tenir compte de l'effet de la dissipation thermique lors de conception et de disposition de votre enceinte, par exemple, des enceintes continuellement exposées à la lumière solaire auront une température interne plus élevée qui pourrait accroître la température de fonctionnement des modules. La fiabilité des modules fonctionnant aux limites extrêmes de la plage de température pendant une période prolongée peut être réduite.

### Enclosure Requirements for a Non-hazardous Environment



**ATTENTION:** An AADvance system must be installed in an IP54 enclosure for use in a Pollution Degree 2 environment or similar in accordance with IEC 60664-1: 2007



**ATTENTION:** Un système AADvance doit être installé dans une enceinte normalisée IP 54 si l'environnement est classé en degré de pollution 2 conformément à la norme CEI 60664-1: 2007

### *Pollution Degree Definition*

For the purpose of evaluating creepage distances and clearances, the following four degrees of pollution in the micro-environment are established:

- Pollution Degree 1: No pollution or only dry pollution occurs. The pollution has no influence.
- Pollution Degree 2: Only non-conductive pollution occurs except that occasionally a temporary conductivity caused by condensation is to be expected.
- Pollution Degree 3: Conductive pollution occurs or dry non-conductive pollution occurs which becomes conductive due to condensation which is to be expected.
- Pollution Degree 4: Continuous conductivity occurs due to conductive dust, rain or other wet conditions.

## **Enclosure Requirements for a Hazardous Environment - Class I, Division 2, Groups A, B, C and D**

The enclosure must comply with the following UL requirements.



**WARNING:** Special Conditions for Safe Use

- Models 9110: The ambient temperature range is -25 °C to +60 °C (-13 °F to +140 °F).
- All other Models: the ambient temperature range is -25 °C to +70 °C (-13 °F to +158 °F).
- Subject devices are to be installed in an ATEX/IECEx Certified, IP54, tool accessible enclosure that has been evaluated to the requirements of EN 60079-0: 2012 + A11:2013, EN 60079-15: 2010/ IEC 60079 -0 Ed 6 and IEC 60079-15 Ed 4. Enclosure is to be marked with the following: "Warning - Do not open when energized". After installation of subject devices into the enclosure, access to termination compartments shall be dimensioned so that conductors can be readily connected. Grounding conductor should have a minimum cross sectional area of 3.31 mm<sup>2</sup>
- Subject devices are for use in an area of not more than pollution degree 2 in accordance with IEC 60664-1.
- Subject devices are to use conductors with a minimum conductor temperature rating of 85 °C.
- Subject devices are to be installed in the vertical orientation only.

**AVERTISSEMENT: Conditions spéciales pour une utilisation sûre**

- Modèles 9110: la plage de température ambiante est de -25 °C à +60 °C;
- Pour tous les autres modèles: la plage de température est de -25 °C à +70 °C;
- Les dispositifs concernés doivent être installés dans une enceinte certifiée ATEX/CEIEx, IP54, accessible à l'aide d'un outil et qui a été évaluée conforme aux exigences des normes EN 60079-0: 2012 + A11:2013, EN 60079-15: 2010/IEC 60079-0 Ed 6 and IEC 60079-15 ed 4. Le marquage suivant doit être apposé sur l'enceinte : « Avertissement - Ne pas ouvrir sous tension ». Après l'installation des dispositifs concernés dans l'enceinte, l'accès aux compartiments de raccordement sera dimensionné de façon à faciliter le raccordement des conducteurs. Le conducteur de mise à la terre devra avoir une section minimale de 3,31 mm<sup>2</sup>.
- Les dispositifs concernés sont utilisables dans un environnement présentant un degré de pollution 2 au maximum conformément à la norme CEI 60664-1;
- Les dispositifs concernés doivent utiliser des conducteurs avec une température nominale minimum de +85 °C ;
- Les dispositifs concernés doivent être installés verticalement uniquement.

**WARNING: EXPLOSION HAZARD**

Do not connect or disconnect equipment while the circuit is live or unless the area is known to be free of ignitable concentrations or equivalent.

**AVERTISSEMENT: RISQUE D'EXPLOSION**

Ne pas connecter ou déconnecter l'équipement alors qu'il est sous tension, sauf si l'environnement est exempt de concentrations inflammables ou équivalente



**WARNING:** Substitution of any component may impair suitability for Class I, Division 2 or equivalent.



**AVERTISSEMENT:** La substitution de composants peut rendre impropre à l'utilisation en Classe I, Division 2 ou équivalente.



**WARNING:** For AADvance modules 9110, 9801,- 9803, 9831- 9833, 9851, 9852, 9892, 9881 and 9882 a disconnect suitable for the location where they are installed shall be provided to allow for removal of power from the fuses before replacement.



**AVERTISSEMENT:** Pour les modules AADvance 9110, 9801,- 9803, 9831- 9833, 9851, 9852, 9892, 9881 et 9882, un sectionneur adapté à l'environnement où ils sont installés devra être fourni pour couper l'alimentation en amont des fusibles avant leur remplacement.

## Estimate Heat Dissipation

The heat in the enclosure is generated from several sources such as the power supplies, the AADvance modules and some of the field loop power. Use the following calculation and the data given in the tables to estimate the overall heat dissipation:

- Power supply consumption (Watts x (100-efficiency) (%)) + the sum of the system power consumed by the modules + part of the field power that is in the enclosure.

The following module power dissipation values are worst case values over the range of operating voltages and currents.

**Table 19 - Module Supply Power Heat Dissipation**

Item	Number of Modules	Module Power Heat Dissipation	Subtotal (W/BTU/hr)
T9110 Processor Module		× 8.0 W (27.3 BTU/hr.)	=
T9401 Digital Input Module 24 Vdc, 8 channel		× 3.3 W (11.3 BTU/hr.)	=
T9402 Digital Input Module 24 Vdc, 16 channel		× 4.0 W (13.6 BTU/hr.)	=
T9431 Analogue Input Module, 8 channel		× 3.3 W (11.3 BTU/hr.)	=
T9432 Analogue Input Module, 16 channel		× 4.0 W (13.6 BTU/hr.)	=
T9451 Digital Output Module, 24 Vdc, 8 channel		× 3.0 W (10.2 BTU/hr.)	=
T9482 Analogue Output Module, 8 channel, isolated		× 3.6 W (12.3 BTU/hr.)	=
		Total:	

The field loop power heat dissipation is generated from the input voltages and currents + the output currents:

**Table 20 - Field Loop Power Heat Dissipation**

Item	Number of Field Loops	Field Loop Power Heat Dissipation	Subtotal (W x 3.412 BTU/hr)
Digital Inputs		× Input Voltage (V)/5125	=
Analogue Inputs		× Input current (A) x 135	=
Digital Outputs		x Output current (A) x 0.57	=
Analogue outputs		x (Field voltage(V) x Output Current (A) - load Resistance (Ω) x Output current (A) <sup>(1)</sup> )	=
		Total:	

(1) The maximum field loop power heat dissipation for analogue outputs should be calculated at an output current corresponding to the smaller of the Maximum Channel Output Current OR Field Voltage/(2 x Load Resistance)

## Backplane Electrical Ratings

To comply with UL/CSA standards use the following voltage and current ratings for the Processor and I/O Backplanes when designing your power distribution:

**IMPORTANT** These are the maximum allowed electrical ratings given by UL for the backplane load installed with the relevant TAs and modules. They are not operating values so don't use them to calculate the controller power consumption or heat dissipation values. Refer to the separate topics on estimating Heat Dissipation and Power Consumption.



Table 21 - Maximum Electrical Rating Values

Module	Back-plane Electrical Ratings		Input/Output Electrical Ratings
	Voltage Range (Vdc)	Maximum Current (mA)	
9100	18-32	10.4A (400 mA per slot)	-
9300	18-32	9.6A (400 mA per slot)	-
9110	18-32	380	-
9401	18-32	260	Input: 18-32 Vdc @ 24 mA
9402	18-32	260	Input: 0-32 Vdc @ 6.5 mA
9431	18-32	260	Input: 0-32 Vdc @ 6.5 mA
9432	18-32	260	Input: 18-32 Vdc @ 24 mA
9481	18-32	260	Output: 18-32 Vdc/0-20 mA
9482	18-32	260	Output: 18-32 Vdc/0-20 mA
9451	18-32	165	Output: 18-32 Vdc @ 0.5 A, Pilot duty 16 VA, 1.5 A Inrush
9801	18-32	6.5	-
9802	18-32	6.5	-
9803	18-32	6.5	-
9831	18-32	0-24	-
9832	18-32	0-24	-
9833	18-32	0-24	-
9851	18-32	500	-
9852	18-32	500	-
9892	18-32	500	-
9881	18-32	0-24	-
9882	18-32	0-24	-

## System Power Requirements

A controller's system power should be supplied from two different 24 Vdc (Nominal) power supplies with a common return path; that is, the 0 V return will be the same between the power feeds. Each controller also requires an external field power source for the field loops.



**WARNING:** A controller system must be installed with a power network that is designed to meet over voltage Category II

This means that a controller must be supplied with system power from a power source that complies with SELV and PELV standards.

- SELV (safety extra-low voltage) is a voltage which is no larger than 30 Vrms, 42.4 Vpeak and 60 Vdc between conductors, or between each conductor and earth in a circuit which is isolated from the line voltage by a safety transformer.
- PELV (protected extra-low voltage) is an extra low voltage circuit with a protective partition from other circuits which has a protective earth connection.

To satisfy SELV and PELV requirements the power source must have a safety transformer with a protective partition between the primary and secondary windings so that the windings are galvanic and electrically isolated.

## Power Arrangements for Field Devices

Output modules use an external source of power for field devices. This may be the power source used for the controller or a separate power source.

- For digital and analogue outputs a field power supply of +24 Vdc within a range of 18-32 Vdc is required.

Recommended field circuits are given for each type of I/O module later in the section "Connecting Field Wiring".

---

**IMPORTANT** It is highly recommended that the negative side of the field supply be connected to earth (ground). This will avoid possible fail danger conditions that can be caused by some earth fault monitors used with floating power supplies.

---

### *Power Distribution Protection*

The power distribution circuit for each field input and for each output module must be protected, externally to the controller. Rockwell Automation recommend that power distribution must meet national and local panel wiring protection standards.

### *Digital Output Field Power*

Special fusing arrangements are required for Digital Output field supplies for UL, ATEX and IECEx approved installations, (see topic on field loops for Digital Output Modules).

## Power Supply and Power Distribution Requirements

The power supplies and power distribution, if incorrectly designed, are a possible electrical or fire safety hazard and can contribute to common cause failure. It is therefore necessary to:

- Establish the power philosophy, specific earthing philosophy, power requirements, and the separation requirements where items of equipment are separately supplied, for example system internal supplies and field loop supplies.
- Make sure that the chosen Power Supply Units (PSUs) are compatible with the power feeds supplied. Alternatively, measures must be put in place to make sure that the power feeds stay within the specifications of the PSUs.
- Define the power distribution requirements, together with the protective philosophy for each distribution; for example, current limited at source or protective devices. Where protective devices are used, it is important to find out that sufficient current will be available to make sure their protective action and the protective device can break the maximum prospective fault current.
- Make sure that the power supplies are sufficient to meet the system load and for any foreseeable load requirements and load transients.
- Make sure that the power supplies have a minimum hold up time of 10 ms.
- Make sure that the power distribution cabling is sized to allow the maximum prospective fault currents and tolerable voltage losses. This is

specifically important where floating supplies are employed and other power sources can cause high prospective fault currents if multiple earth faults occur.

## Estimating Power Consumption

To estimate the power supply requirements (power supply sizing) you need to know the power consumption of all the modules. Use the following table to estimate the system power consumption.

**Table 22 - Module Supply Power Consumption**

Item	Number of Modules	Power Consumption	Subtotal (W)
T9110 Processor Module		× 8.0 W	=
T9401 Digital Input Module 24 Vdc, 8 channel		× 3.3 W	=
T9402 Digital Input Module 24 Vdc, 16 channel		× 4.0 W	=
T9431 Analogue Input Module, 8 channel		× 3.3 W	=
T9432 Analogue Input Module, 16 channel		× 4.0 W	=
T9451 Digital Output Module, 24 Vdc, 8 channel		× 3.0 W	=
T9482 Analogue Output Module, 8 channel, isolated		× 3.6 W	=
		Total:	

**IMPORTANT** The above figures are worst case values calculated from the range of operating voltages and currents. If your system is required to meet UL/CSA standards the power consumption and the corresponding electrical ratings must not exceed the maximum electrical ratings given in the table included in the topic "Backplane Electrical Ratings".

### Field Power Consumption

To estimate overall controller power dissipation it is necessary to include the field power component dissipated within the controller. Refer to the table "Field Loop Power Heat Dissipation". The field power requirements should be calculated separately and is dependent on the number and type of field elements. Refer to the specifications for the Digital and Analogue output modules for details of the channel output electrical specifications.

**Notes:**

## Module Overview and Specifications

This chapter gives a brief technical overview and technical specification of each module and related termination assemblies.

### T9110 Processor Module

The T9110 processor module is the central processing unit of an AADvance® controller. It carries out the following process and safety controller tasks:

- Execution of the AADvance Safety Kernel to solve application logic
- Interfacing with the controller I/O modules, reading and processing input data and writing output data
- Communication with other processor modules, both locally and across the control network
- Initiation of periodic diagnostics for the controller
- Communication with other systems such as HMIs
- Message encapsulation and verification for secure channel communication to other nodes

Each processor module is galvanically isolated from external power supplies and data links so that any faults developed in the field cannot cause the module to fail. The module will continue to operate if a failure occurs in one of its dual redundant 24 Vdc power supplies. The module incorporates under- and over-voltage protection for its internal power supplies, which show a 'power valid' signal to the module's own diagnostics microprocessor.

The modules regularly initiate internal diagnostic tests which, together with a watchdog circuit, monitor the processor performance. If the tests find a serious fault, the processor module will shut down. A single processor system will fail-safe. If a controller uses two or three processor modules and one processor module develops a fault, you can fit a new processor module while the controller is on-line without interrupting the operation of the other processors. The new processor module automatically carries out self-education and synchronizes with the other processors. Fault detection and fail-over in redundant processor configurations is automatic and has no impact on controller operation.

## T9110 Processor Module Specification

Table 23 – Processor Module Specification

Attribute	Value
<b>Functional Characteristics</b>	
Degradation	1oo1D, 1oo2D and 2oo3D <sup>(1)</sup>
Processor clock	400 MHz
Memory	
Boot flash	512 kB
SRAM	512 kB
Bulk flash	64 MB
SDRAM	32 MB
Sequence of events	(for internal variables)
Event resolution	1 ms
Time-stamp accuracy	Application Scan
Self Test Interval	< 5.5 hours
<b>Performance Characteristics</b>	
Safety Integrity Level (SIL)	1 processor: non-safety applications up to SIL 1 2 Processors: up to SIL 3 safety applications 3 Processors: up to SIL 3 fault tolerant and TMR safety applications
I/O Modules supported	48
<b>Electrical Characteristics</b>	
Module supply voltage	
Voltage	Redundant + 24 Vdc nominal; 18-32 Vdc range
Module supply power dissipation	8 W (27.3 BTU/h)
Typical Surface Temperature of an Operating Module	43 °C ± 5 °C
<b>Mechanical Specification</b>	
Dimensions (height × width × depth)	166 mm × 42 mm × 118 mm (6-½ in. × 1-5/8 in. × 4-5/8 in.)
Weight	430 g (15 oz.)
Casing	Plastic, non-flammable

(1) When a controller's processor modules have degraded to 1oo1D, the system must be restored to at least 1oo2D by replacing the faulty processor module(s) within the MTTR assumed in the PFD calculations; also, unless compensating measures are defined in the Safety Requirements Specification (SRS) and documented in operating procedures, the application program must be designed to shut down safety instrumented functions if a module failure due to dangerous fault has not been replaced within the MTTR.

## T9100 Processor Base Unit

Processor base unit supports up to three processor modules as a redundant group. The processor base unit supplies the electrical connections between the T9110 processor modules, and for the remaining controller modules. Each base unit can be mounted onto standard DIN rails or directly onto a panel or wall. The moldings use slots and clamps for DIN rail mountings, and holes for screw fixing to flat panels.

The processor base unit holds the IP address of each processor module separately in a BUSP component that is installed during manufacture. This allows you to remove a faulty processor module and install a new one without needing to set up the IP address of the replacement module.

Figure 27 - Processor base unit

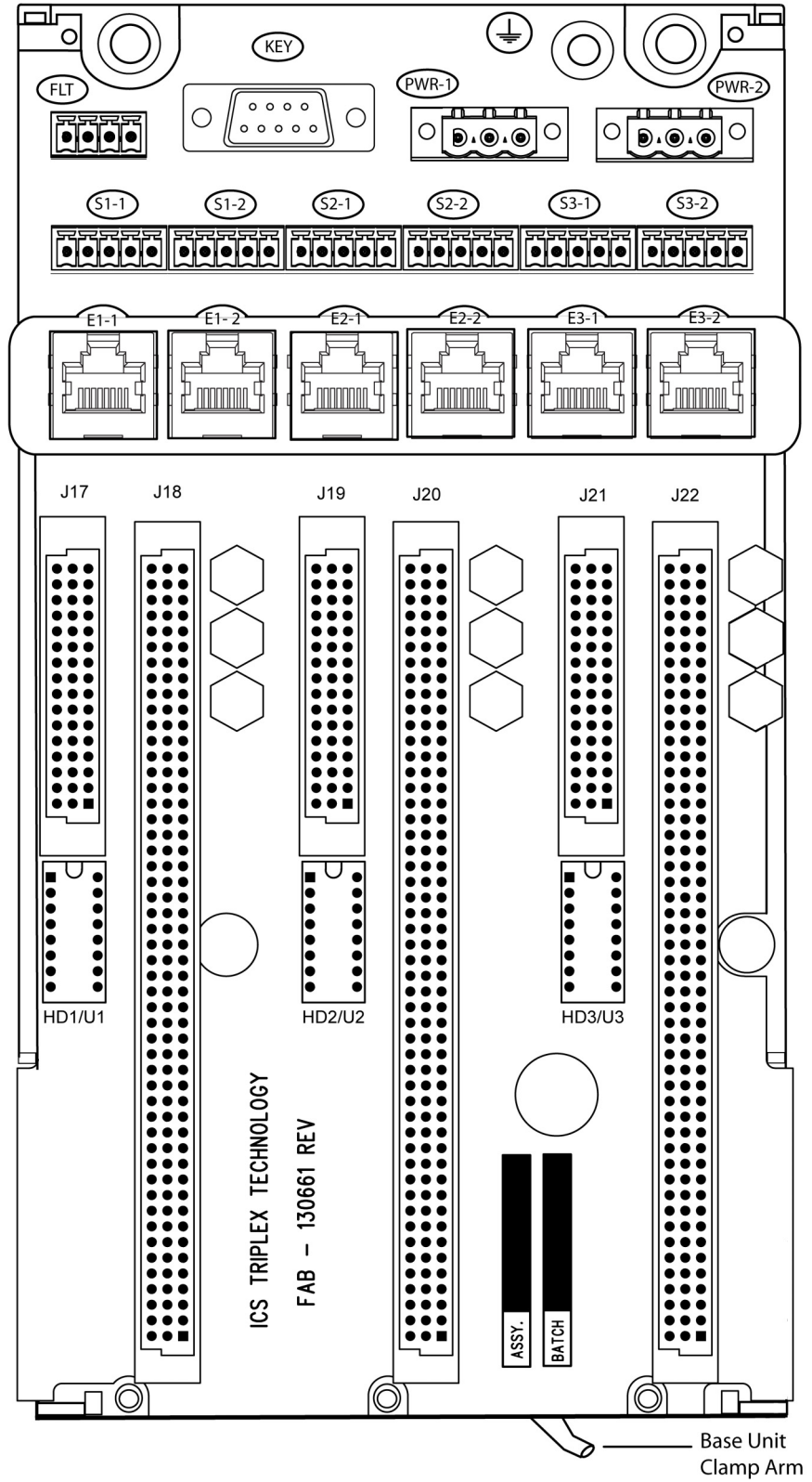

## T9100 Base Unit Specification

Table 24 - T9100 Processor Base Unit Specification

Attribute	Value
<b>Electrical Specification</b>	
Supply voltage requirements	Redundant + 24 Vdc nominal; 18 Vdc to 32 Vdc range
Number of processor modules supported	1, 2 or 3
Number of I/O base units supported	16: 8 for each I/O bus
E1-1, E1-2; E2-1, E2-2; E3-1, E3-2	Connectors for Ethernet Ports 1 & 2 for Processor A, B and C Wiring: shielded RJ45 sockets according to IEC6063-7, 2- or 4-pair shielding
S1-1, S1-2; S2-1,S2-2; S3-1, S3-2	Connectors for Serial Ports 1 & 2 for Processor A, B and C Wiring: Six 5-way connectors; maximum 1.31 mm <sup>2</sup> (16 AWG), Stripping length 7 mm (9/32 in.)
PWR-1, PWR-2	Connectors for Redundant +24Vdc Power Supplies. Wiring: Two 3-way connectors, Conductor cross section maximum 3.3 mm <sup>2</sup> (12 AWG); Stripping length 7 mm (9/32 in.)
FLT	Not used
KEY	Connector for the Program Enable Key
<b>Mechanical Specification</b>	
Dimensions (height × width × depth)	235 mm x 126 mm (9 1/4 in. x 5 in.)
Weight	460g (16 oz.)

### T9300 I/O Base Unit (3 way)

The AADvance controller has T9300 I/O base units for the I/O modules. An I/O base unit supports a maximum of three I/O modules (of any type), and their related termination assemblies. Each base unit can be mounted onto standard DIN rails or directly onto a panel or wall. The moldings use slots and clamps for DIN rail mountings, and holes for screw fixing.

It contains a passive backplane that supplies the electrical connections between the I/O modules and the T9100 processor base unit; i.e. the command and response buses and the system power.



Figure 28 - I/O Base Unit

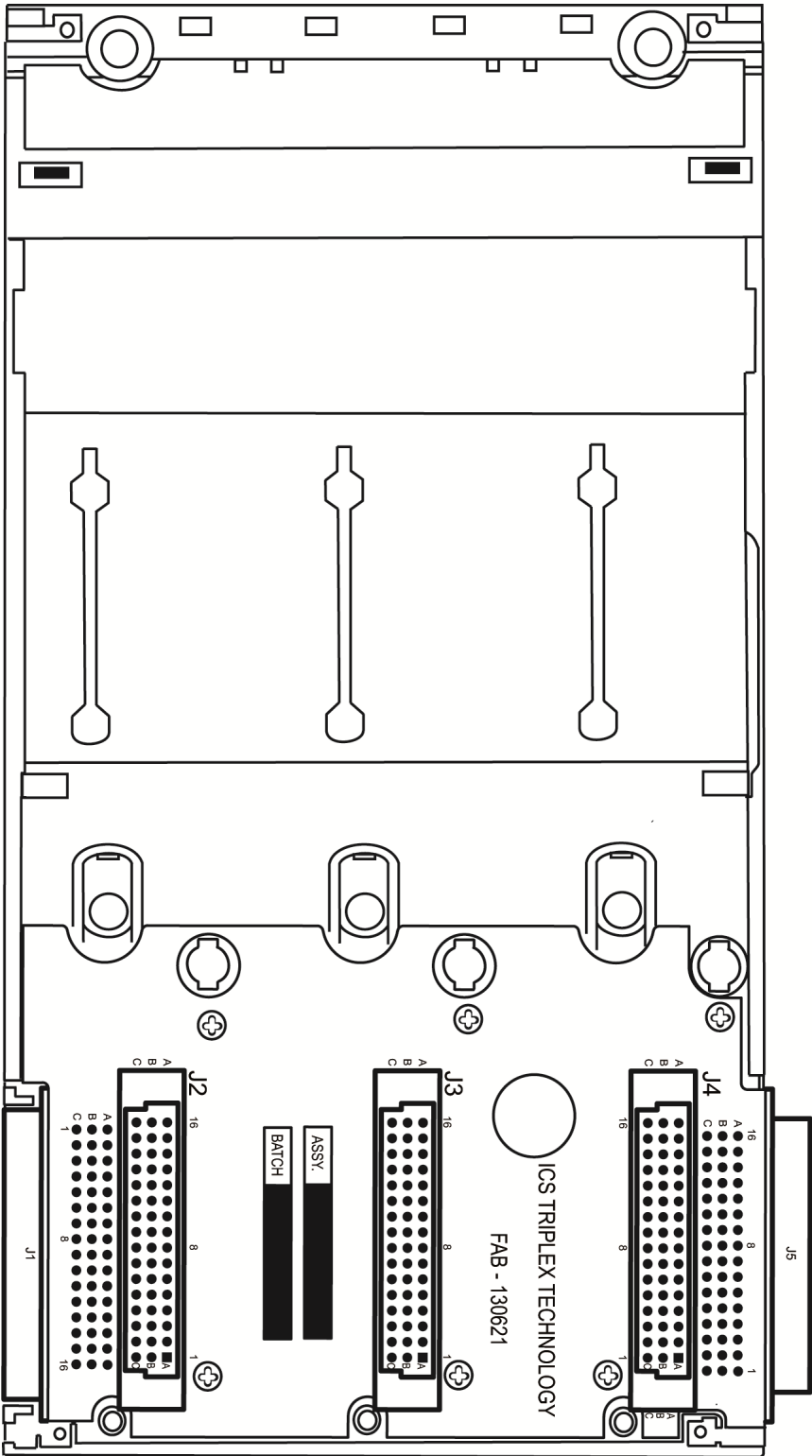

The bus and power connections from the processor base unit go into the backplane at the left connector and are routed direct to the module connectors. The backplane has a connector at the right for the next I/O backplane. The

connection to the left of the backplane can connect to a processor base unit or another I/O base unit.

Adjacent base units clip together and are held in position by a plastic retaining clip. Alternatively rows of I/O base units can be connected together using a T9310 expansion cable assembly.

## T9300 Base Unit Specification

Table 25 - T9300 Base Unit Specification

Attribute	Value
<b>Electrical Specification</b>	
Supply voltage requirements	Redundant + 24 Vdc nominal; 18 Vdc to 32 Vdc range (from Processor Base unit)
<b>Physical Specification</b>	
Number of I/O modules supported	1, 2 or 3
Command busses	One
Response busses	24
Buses per system	2
Base units per bus	8
I/O Modules per bus	24 individual modules (not counting grouping) (e.g. 12 dual or 8 triple module groups)
<b>Mechanical Specification</b>	
Dimensions (height × width × depth)	235 mm x 126 mm (9 1/4 in. x 5 in.)
Weight	133 g (5 oz.)

## T9310 Expansion Cable Assembly

The T9310 expansion cable assembly connects a T9300 I/O base unit to a different I/O base unit or to the T9100 processor base unit. The assembly consists of a cable, terminated by multi-way plugs, and a pair of adaptors.

One end has a cable socket assembly and the other end a cable plug assembly that connects to the right-hand bus connector of an I/O base unit or to I/O Bus2 (the left hand connector) of a processor base unit. The socket connects to the left-hand bus connector of an I/O base unit.

The expansion cable offers the following features:

- Two meter cable length
- Secured with retaining screws and screw cap screws
- Connects all command and response signals and system power
- Screened to decrease resonance emissions

Figure 29 - Expansion Cable

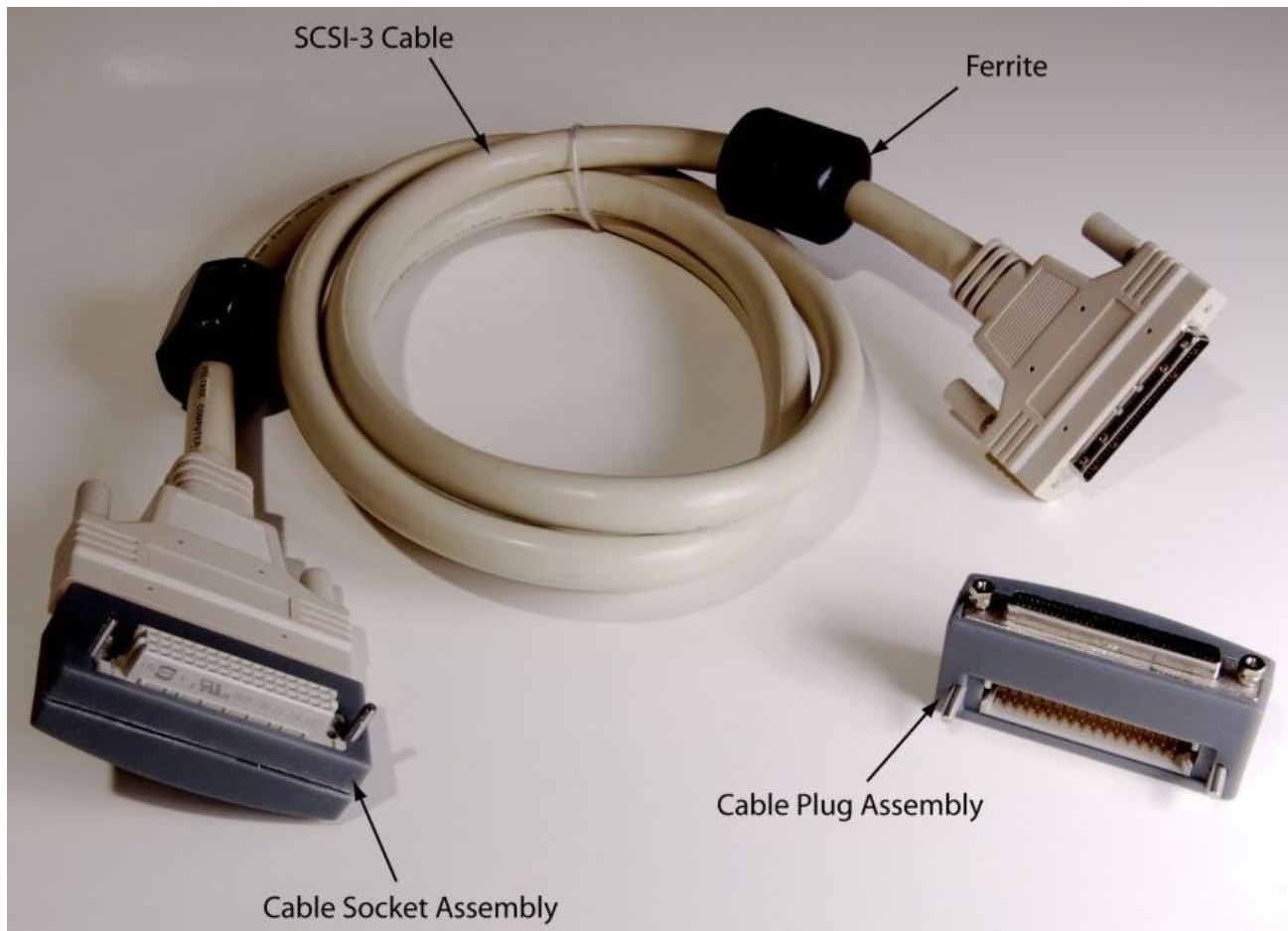

### T9310 Extension Cable Specification

Table 26 - T9310 Extension Cable Specification

Attribute	Value
<b>Electrical Specification</b>	
Carries the following Signals:	Command Bus I/O Response Bus x 24 Backplane 0 V Return Redundant System +24 Vdc_1 & 2 power supplies
<b>Mechanical Specification</b>	
Length	2 m (78.74 in.)
Weight	
SCSI-3 Cable Assembly	57 g (2 oz.)
Cable Plug Assembly	50 g (2 oz.)
Cable Socket	50 g (2 oz.)

### T9401/2 Digital Input Module, 24 Vdc, 8/16 channel

The T9401/2 digital input module monitors eight (T9401) or sixteen (T9402) isolated digital input channels and measures input voltages in the range 0 V to 32 Vdc. Each channel supplies the digital state and voltage data to the processor module for field device state, line monitoring and field fault detection.

Input modules give module and individual channel status indications through the front panel LEDs. These status indications are also connected to application variables and viewed at the Workbench. Comprehensive diagnostics at both system and module levels give clear fault indications which help fast maintenance and repair.

Signal and power isolation circuits divide each input channel from the remainder of the system, protecting the controller from field faults. An independent watchdog arrangement monitors the module operation and gives more fault containment by a shutdown mechanism should a fault occur.

These modules mate with the T9801/2/3 Digital input termination assemblies. When digital input modules are installed in a dual or TMR configuration they provide fault tolerant input functionality, enabling you to replace a faulty input module without interrupting the channel data flow to the processor modules.

## T9401/2 Digital Input Module Specification

**Table 27 - T9401/2 Digital Input Module Specification**

Attribute	Value
<b>Functional Characteristics</b>	
Input Channels	T9401: 8 T9402: 16
<b>Performance Characteristics</b>	
Safety integrity level	IEC 61508 SIL 3 <sup>(1)</sup>
Safety level degradation	1oo1D, 1oo2D, 2oo3D
Safety accuracy limit	1.0 Vdc
Self test interval	< 1 hour; system dependent
Sample update interval (no filter)	6 ms
Sequence of events Event resolution Time-stamp accuracy	1 ms 10 ms
<b>Electrical Characteristics</b>	
Module Supply Voltage:	
Voltage	Redundant + 24 Vdc nominal; 18 Vdc to 32 Vdc range
Module supply power dissipation	T9401: 3.3 W (11.3 BTU/hr.) T9402: 4.0 W (13.6 BTU/hr.)
Input data voltage range	0V to 32 Vdc
Maximum Slew Rate	See <a href="#">Figure 30</a> below <sup>(2)</sup>
Maximum Transition Rate	1/(Application Scan Time + 10 ms) Hz <sup>(2)</sup>
Input channel load	see TA specification
Input measurement voltage accuracy	± 0.5 V
Input measurement voltage resolution	5 mV 13-bit
Field loop power dissipation	(see T9801/2/3 Termination Assembly)
Channel Isolation maximum withstand	± 1.5 KVdc for 1 minute
<b>Mechanical Specification</b>	
Dimensions	166 mm x 42 mm x 118 mm (6½ in. x 1 21/32 in. x 4 21/32 in.)
Weight	T9401: 280 g (10 oz.) T9402: 340 g (12 oz.)
Casing	Plastic, non-flammable

- (1) SIL 3 is the maximum achievable SIL for a single channel. Selected CPU, input and output voting configurations could increase or decrease the SIL achieved.
- (2) The input slew may exceed the specified levels providing the duration of the transgression is less than the process safety time of the configured module.

**Figure 30 - Digital Input Slew Tolerance**

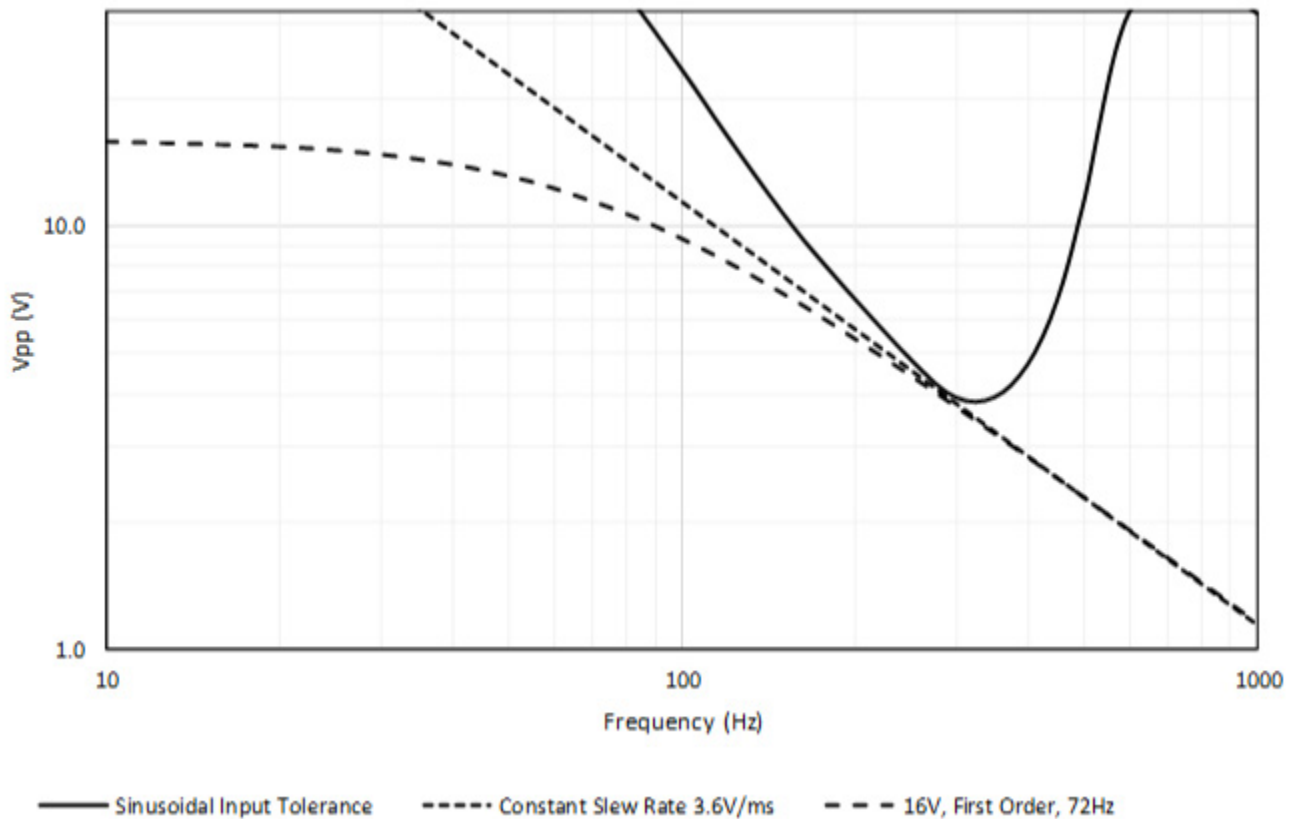

Transgression of the slew rate limits identified above may lead to channel failure resulting from diagnostics otherwise designed to verify that channels are operating within their defined safety accuracy.

## T9801/2/3 Termination Assemblies for Digital Inputs

There are three termination assemblies for use with digital input modules that supply simplex, dual and triple modular redundant configurations.

A T9801 termination assembly is for a simplex application and has terminations for 16 non-isolated digital inputs, it has connections for one T9401 or T9402 digital input module. The T9802 and T9803 termination assemblies support 16 isolated digital inputs for dual and triple modular redundant arrangements of digital input modules.

Illustrated is the T9802 dual termination assembly.

Figure 31 - Digital/Analogue Input Termination assembly

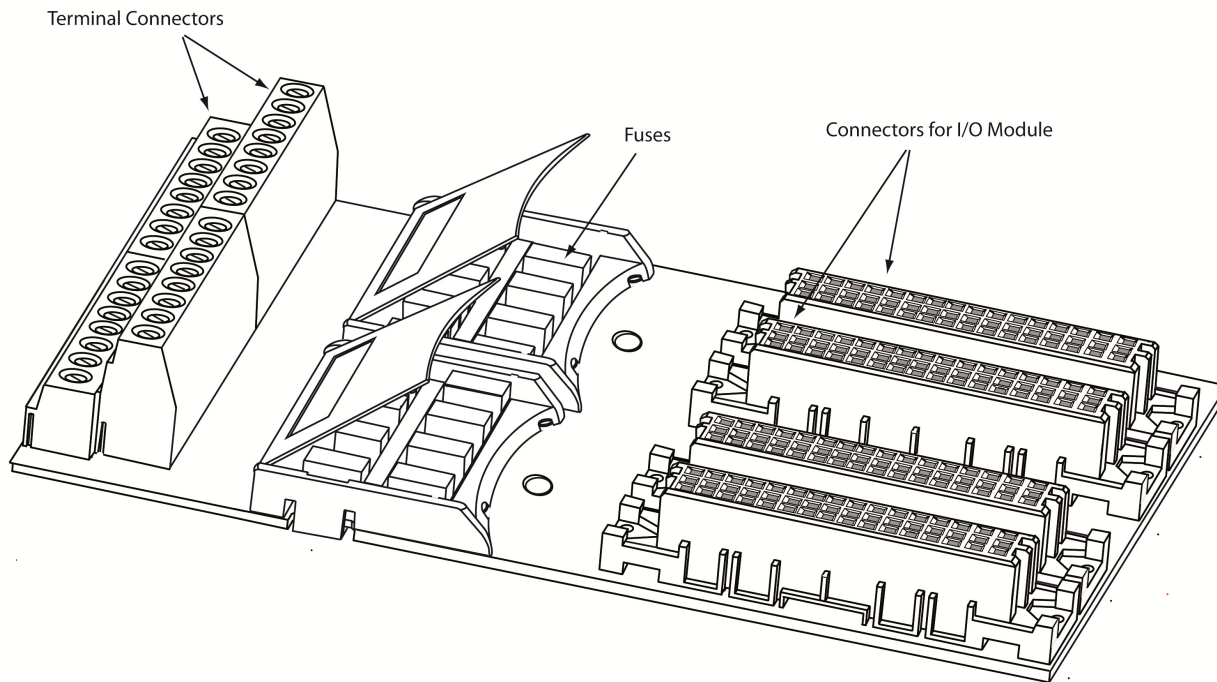

A replaceable fuse protects each channel from field faults. Fuses can be replaced without removing a module or the termination assembly.

### T9801/2/3 Digital Input Termination Assembly

A T9801 termination assembly is for a simplex configuration and has terminations for 16 non-isolated digital inputs. The T9802 and T9803 termination assemblies support 16 isolated digital inputs for dual and triple modular redundant arrangements of digital input modules.

Table 28 - T9801/2/3 Digital Input TA Characteristics

Attribute	Value
<b>Functional Characteristics</b>	
Field Connections	16; wiring: Conductor cross section maximum 1.31 mm <sup>2</sup> (16 AWG); Stripping length 6 mm (¼ in.)
Input modules supported	
T9801	One T9401/2
T9802	Two T9401/2
T9803	Three T9401/2
<b>Electrical Characteristics</b>	
Input channel fuses	50 mA, 125 V, Type T manufactured by Littelfuse
Channel load	(5.125 ± 0.2 %) kΩ
Input measurement voltage resolution	5 mV, 13 bit
Channel isolation	
T9801	None
T9802, T9803:	± 1.5 kVdc maximum withstanding for 1 minute
Maximum field loop power dissipation	0.2 W for each field loop (0.68 BTU/hr)

## T9431/2 Analogue Input Module, 8/16 Channel

The T9431/2 analogue input has eight (T9431) or sixteen (T9432) isolated analogue input channels and measures input current in the range 0 mA to 24 mA. Each channel supplies digital state and analogue data to the processor for process monitoring. Each input has five configurable voltage bands (there are eight distinct switching thresholds to allow hysteresis), each of which can be adjusted to supply line monitoring and field device diagnostics.

The input module makes local module and channel status indications through its front panel LEDs, the same indications can be connected to application variables and viewed at the Workbench. Comprehensive diagnostics at system and module levels give clear indications which help fast maintenance and repair.

The module incorporates signal and power isolation circuits, which divide each input channel from the remainder of the system, protecting the controller from field faults. An independent watchdog arrangement monitors the module operation and supplies more fault containment by a shutdown mechanism if a fault occurs.

These modules mate with the T9831/2/3 Analogue Input termination assemblies. When analogue modules are installed in a dual or TMR configuration they supply fault tolerant input functionality, enabling you to replace input modules without interrupting the channel input data flow to the processor modules.

This module supports HART commands #03 to collect data from the field device. The application can be configured to use HART information to monitor and respond to device conditions, it may also be used to supply module diagnostic information such as comparison and error reporting.

### Analogue Input Line Monitoring

Each analogue input module is set up through the AADvance Workbench. Monitoring levels for each input channel are configurable at both the module and channel level. The default parameters are:

- Fault: 0 mA to 3.8 mA
- Normal: 3.8 mA to 22.0 mA
- Fault: > 22.0 mA

## T9431/2 Analogue Input Module Specification

**Table 29 - Analogue Input Module Specification**

Attribute	Value
<b>Functional Characteristics</b>	
Input channels:	T9431: 8 T9432: 16
Degradation	1oo1D, 1oo2D and 2oo3D
<b>Performance Characteristics</b>	
Safety integrity level	IEC 61508 SIL 3 <sup>(1)</sup>
Safety level degradation	1oo1D, 1oo2D and 2oo3D
Safety accuracy limit	200 µA

**Table 29 - Analogue Input Module Specification**

<b>Attribute</b>	<b>Value</b>
Self test interval	< 1 hour; system dependent
Sample update interval (no filter)	6 ms
Value of least significant bit	0.98 $\mu$ A
Error at 25 °C $\pm$ 2 °C After 1 year at 40 °C After 2 years at 40 °C After 5 years at 40 °C	0.21 % + 10 $\mu$ A 0.22 % + 10 $\mu$ A 0.23 % + 10 $\mu$ A
Temperature drift	( 0.01 % + 0.3 $\mu$ A ) per °C
<b>Electrical Characteristics</b>	
Module supply voltage:	
Voltage	Redundant + 24 Vdc nominal
Module supply power dissipation	T9431: 3.3 W (11.3 BTU/hr) T9432: 4.0 W (13.6 BTU/hr)
Input Current	
Nominal	4 mAdc to 20 mAdc
Maximum range	0 mAdc to 24 mAdc
Maximum Input Slew Rate	See <a href="#">Figure 32</a> below <sup>(2)</sup>
Input channel load	see TA Specification
Resolution	0.98 $\mu$ A, 15-bit
Measurement calibrated accuracy at 25 °C	$\pm$ 0.05 mA
Field loop power dissipation	see 9831/2/3 TA Specification
Channel isolation - maximum withstanding	$\pm$ 1.5k Vdc for 1 minute
<b>Mechanical Specification</b>	
Dimensions (height $\times$ width $\times$ depth)	166 mm $\times$ 42 mm $\times$ 118 mm (6-1/2 in. $\times$ 1-21/32 in. $\times$ 4-21/32 in.)
Weight	T9431: 280 g (10 oz.) T9432: 340 g (12 oz.)
Casing	Plastic, non-flammable

(1) SIL 3 is the maximum achievable for a single channel. Selected CPU, input and output voting configurations could increase or decrease the correct SIL achieved.

(2) The input slew may exceed the specified levels providing the duration of the transgression is less than the process safety time of the configured module.



Figure 32 - Analogue Input Slew Tolerance

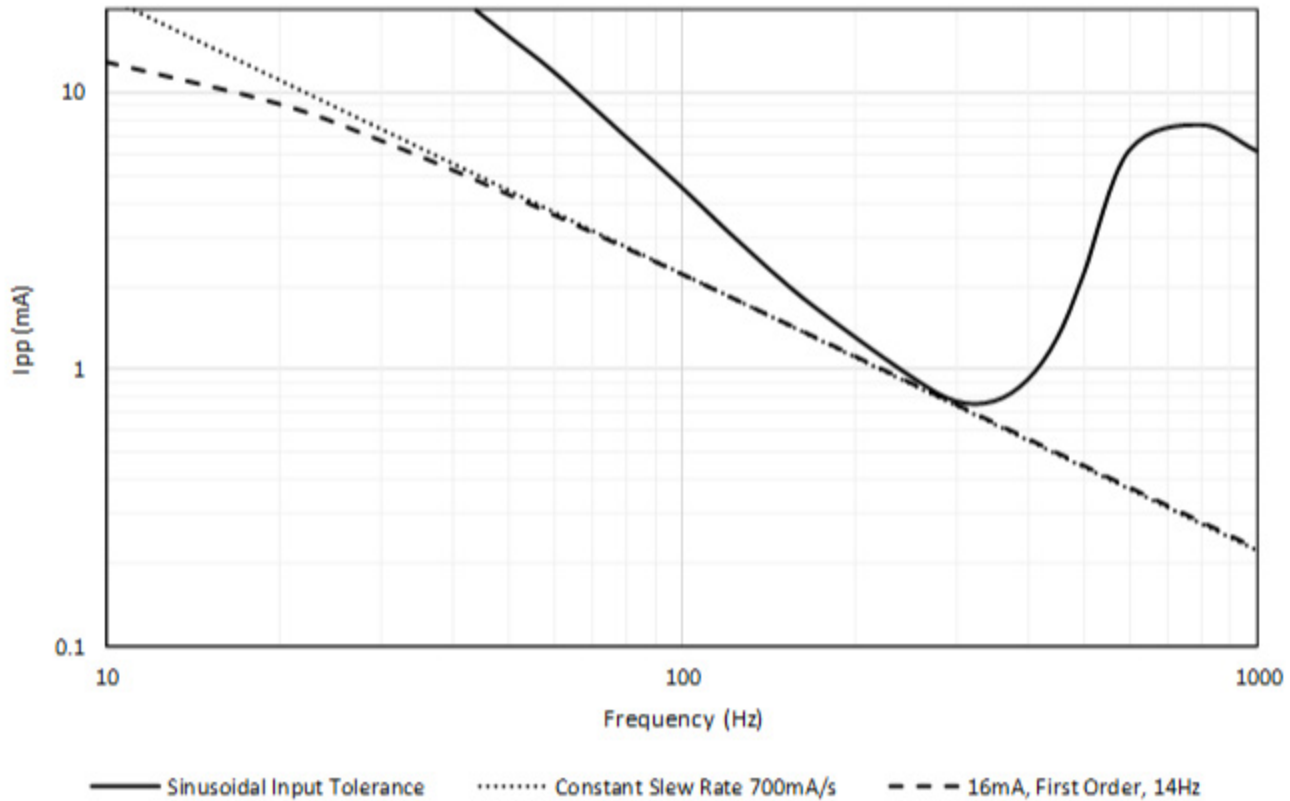

Transgression of the slew rate limits identified above may lead to channel failure resulting from diagnostics otherwise designed to verify that channels are operating within their defined safety accuracy.

## T9831/2/3 Termination Assemblies for Analogue Inputs

There are three termination assemblies for use with analogue input modules for simplex, dual and triple modular redundant configurations.

A T9831 termination assembly is for a simplex application and has terminations for 16 non-isolated analogue inputs. It supports one T9431 or T9432 analogue input module. The T9832 and T9833 termination assemblies support 16 isolated analogue inputs for dual and triple modular redundant arrangements of analogue input modules. Illustrated is the T9832 termination assembly:

Figure 33 - Digital/Analogue Input Termination assembly

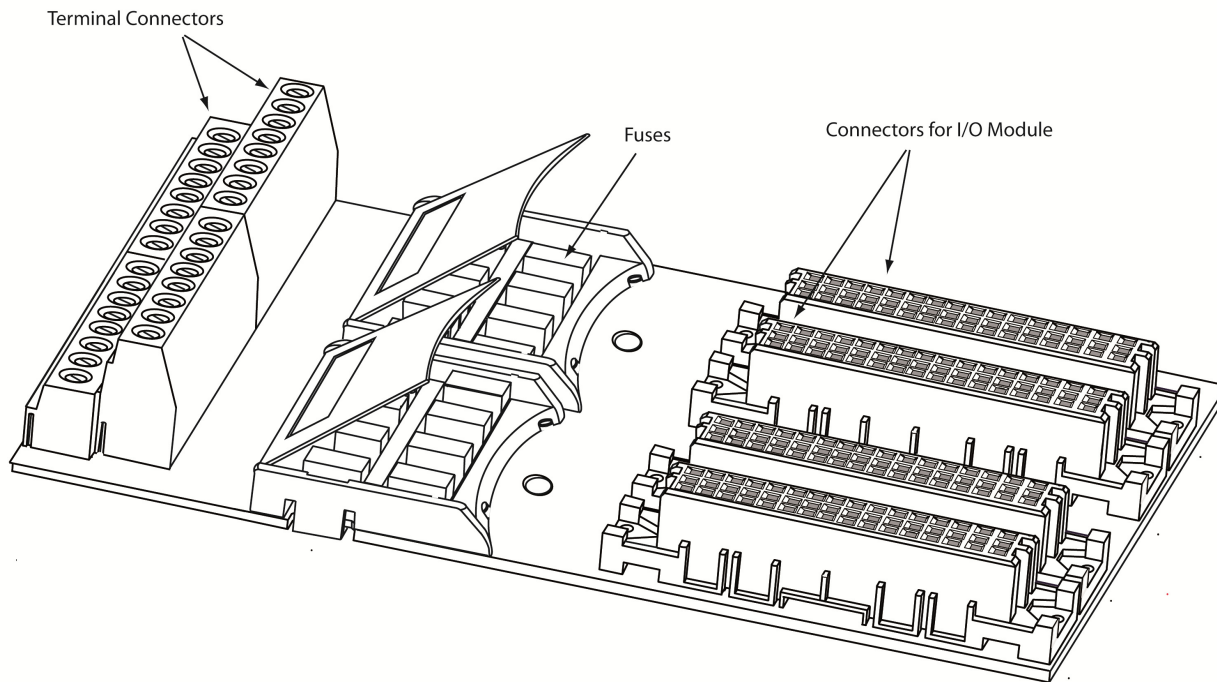

The termination assembly protects each sensor input signal by a 50 mA fuse. Fuses can be replaced without removing an I/O module or termination assembly.

### Analogue Input Termination Assembly

A T9831 termination assembly is for a simplex configuration and has terminations for 16 non-isolated digital inputs. The T9832 and T9833 termination assemblies support 16 isolated digital inputs for dual and triple modular redundant arrangements of digital input modules.

Table 30 - T9831/2/3 Analogue Input TA Specification

Attribute	Value
<b>Functional Characteristics</b>	
Field connections	16; Wiring: Conductor cross section maximum 1.31mm <sup>2</sup> (16 AWG); Stripping length 6mm (¼ in.)
Number of input modules supported	
T9831	One
T9832	Two
T9833	Three
<b>Electrical Characteristics</b>	
Input channel fuses	50 mA, 125 V, Type T manufactured by Littelfuse
Channel load	(135 ± 0.2 %) Ω
Channel isolation:	

**Table 30 - T9831/2/3 Analogue Input TA Specification**

Attribute	Value
T9831	None
T9832/T9833	± 1.5 kVdc Maximum withstanding for 1 minute
Maximum field loop power dissipation	0.08 W for each field loop (0.27 BTU/hr)

## T9451 Digital Output Module, 24Vdc, 8 channel

The T9451 digital output module has 8 channels for a maximum of 8 field elements and can switch 1 A at 32 Vdc for each device. It features voltage and load current monitoring on each channel, reverse current protection and short and open circuit line monitoring. It is designed to always be able to switch off an output when demanded. No single failure in the module can cause a stuck-on failure. The module supports dual redundant power feeds for field devices without the need for external diodes.

The output module isolates the processor module from the output channel control and data management circuits, thus protecting the processor module from possible faults in the output control circuits and field connections. An output channel protection activates when the channel load exceeds a safe limit. And, a reverse voltage protection circuit in each output channel verifies that externally applied voltages do not supply current flow into the module outputs.

The module has self-checking functionality. Short circuit and open circuit line monitoring is supplied on all outputs (see article [605753](#) on the Rockwell Automation Knowledgebase website). Internal diagnostics do ongoing functionality checks ensuring that the output channel command data is correctly transferred to the output. The processor module initiates a test sequence on each output channel, checking for 'stuck-on' and 'stuck-off' conditions on the output switch pairs. Front panel LEDs give module, channel and field connection status indications. These status indications can also be connected to application variables and viewed at the Workbench.

When a controller uses a pair of digital output modules in a dual configuration, the two fail-safe output switches on each channel are combined in a parallel arrangement so that they automatically form a fault-tolerant output configuration.

The AADvance Workbench has settings for individual digital output channels:

- You can specify a shutdown state for an output channel that defines how the output will behave when the module is in a shutdown mode.
- You can disable the line test feature for an output that disables detection of a no-load condition (e.g. for used output channels).

## T9451 Digital Output Module Specification

**Table 31 - Digital Output Module Specification**

Attribute	Value
<b>Functional Characteristics</b>	
Output channels	8
<b>Performance Characteristics</b>	

**Table 31 - Digital Output Module Specification**

Attribute	Value
Safety integrity level	IEC 61508 SIL 3 <sup>(1)</sup>
Safety level degradation	1oo1D, 1oo2D
Self-test interval	<30 minutes (30s for each module)
<b>Electrical Characteristics</b>	
Module supply voltage:	
Voltage	Redundant +24 Vdc nominal; 18 Vdc to 32 Vdc
Module supply power dissipation	3.0 W (10.2 BTU/hr.)
Output Voltage:	
Maximum voltage without damage	-1 V to +60 Vdc
Operating field supply voltage	18 Vdc to 32 Vdc
Maximum Field Voltage Slew Rate	150 V/s [ <sup>(2)</sup> , <sup>(3)</sup> ]
Output current:	
Minimum current required for line monitoring	10 mA for each module (20 mA for dual pair)
Maximum voltage drop	1 Vdc
Maximum current at de-rated temperature De-rated current at maximum temperature	8 A all channels @ 60 °C 6 A all channels @ 70 °C
Maximum De-energised Output Voltage Slew Rate	12 V/ms <sup>(4)</sup>
Maximum Energised Output Current Slew Rate	0.9 A/ms <sup>(4)</sup>
Output off resistance (effective leakage)	50 K $\Omega$
Voltage monitoring accuracy	$\pm$ 0.5 V
Current monitoring accuracy	$\pm$ 10 mA
Output overload protection	
Surge	2 A for up to 50 ms
Continuous	1.5 A
Maximum field loop power dissipation	0.57 W for each field loop (1.94 BTU/hr.)
<b>Mechanical Specification</b>	
Dimensions (height $\times$ width $\times$ depth)	166 mm $\times$ 42 mm $\times$ 118 mm (6-1/2 in. $\times$ 1-21/32 in. $\times$ 4-21/32 in.)
Weight	340 g (12 oz.)
Casing	Plastic, non flammable

(1) SIL 3 is the maximum achievable for a single channel. Selected CPU, input and output voting configurations could increase or decrease the correct SIL achieved. Refer to the Safety Manual for more details.

(2) Limit not applicable if all outputs are energised.

(3) Limit not applicable if perturbations are less than 2.0 Vpp or last less than 3 minutes in any 60 minute period.

(4) Limit not applicable to transgressions lasting less than the process safety time configured for the module.

Transgression of the slew rate limits identified above may lead to channel failure resulting from diagnostics otherwise designed to verify that channels are operating within their defined safety accuracy.

## T9851/2 Termination Assemblies for Digital Outputs

A T9851 is a simplex termination assembly for 8 digital output channels. The T9852 is a dual 8 channel output termination assembly. The terminal blocks also accept two 24 Vdc power sources for field power. The termination assembly incorporates two replaceable 10 A fuses, one for each field power source.

## T9851/2 Digital Output Termination Assembly Specifications

Table 32 - Digital Output TA Specification

Attribute	Value
<b>Functional Characteristics</b>	
Field connections	8; Wiring: Conductor cross section maximum 1.31 mm <sup>2</sup> (16 AWG); Stripping length 6mm (¼ in.)
Modules supported	T9851 : one T9852 : two
<b>Electrical Characteristics</b>	
Field supply fuses	10 A for each field supply
<b>Mechanical Specification</b>	
Dimensions (height x width)	
T9851	132 mm × 42 mm (5-¼ in. × 1-21/32 in.)
T9852	132 mm × 84 mm (5-¼ in. × 3-5/16 in.)
Weight	
T9851	133 g (5oz.)
T9852	260 g (10oz.)

## T9892 Digital Output Termination Assembly

The T9892 Terminal Assembly module operates in conjunction with the T9451 Digital Output Module and provides 8 dual configuration output channels. It shares the same pin-out as the standard AADvance T9852 Digital Output Terminal Assembly and has the same coding peg configuration. However, the T9852 termination has a separate a connector for the field power input voltage connections and additional fusing for protection against field faults.

Figure 34 - Schematic T9882

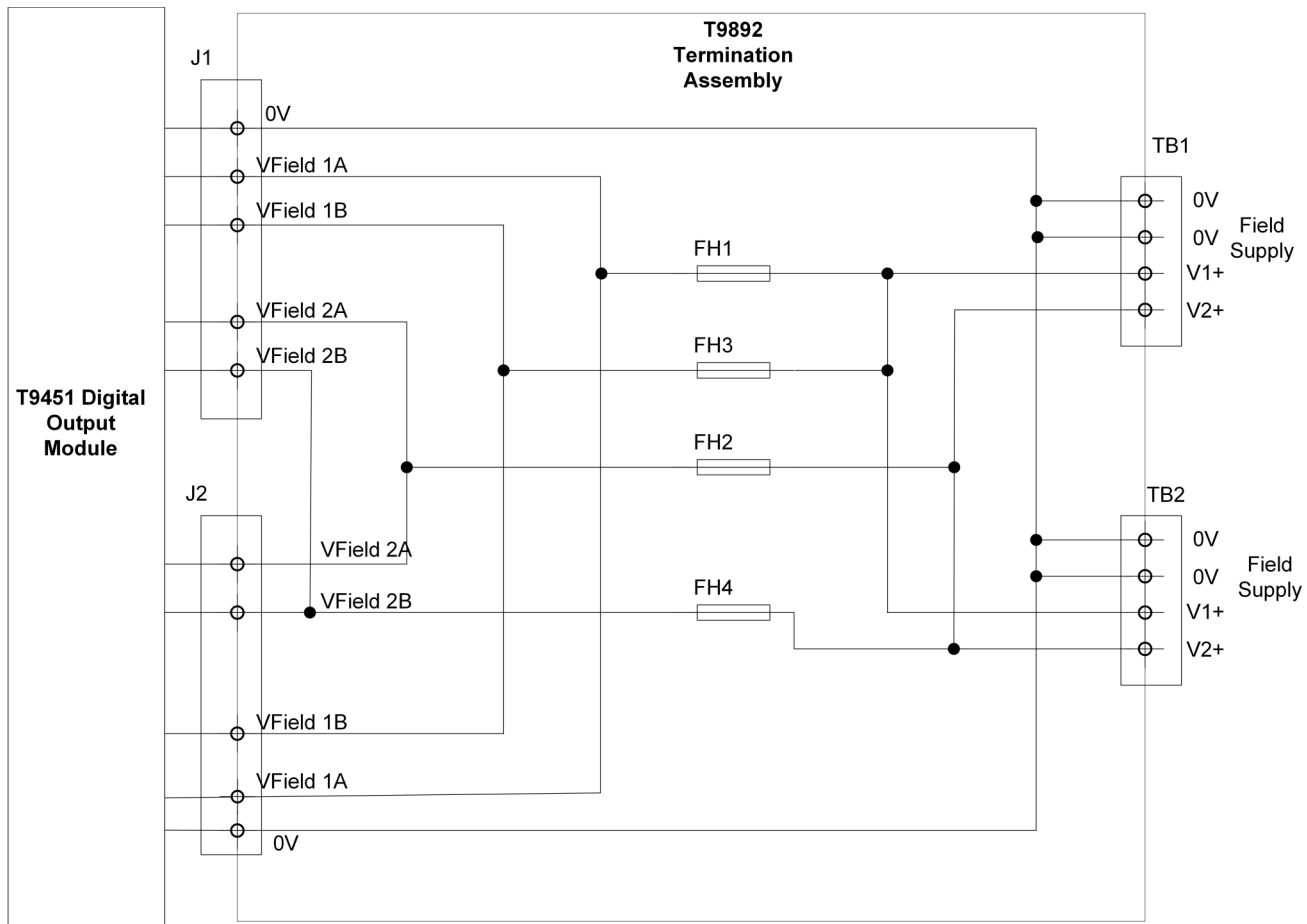

## T9481/2 Analogue Output Module

The T9481 and 9482 analogue output modules deliver 4 mA to 20 mA output current for field devices. Each channel is a current sink device and in simplex mode a channel drops the full demanded current. In dual module operation each channel drops half the output current.

The module features voltage and load current channel monitoring, reverse current protection and short and open circuit line monitoring. It is designed to always be able to switch off an output when demanded.

Internal diagnostics do continuous functionality checks. All module, channel and status information is displayed on front panel indicators and status data is routed to the AADvance where it can be viewed and checked. The module has a user configurable failure mode that can be set outputs to hold last state, fail safe, or a user specified output state. In dual mode the two modules communicate with each other by an inter-module link to maintain fault tolerant operation'.

This module supports HART commands #03 to collect data from the field device. The application can be configured to use HART information to monitor and respond to device conditions. It may also be used to supply diagnostic information such as comparison and error reporting.

## T9481/2 Analogue Output Module Specification

Table 33 - Analogue Output Module Specification

Attribute	Value
<b>Functional Characteristics</b>	
Output channels	T9481: 3 T9482: 8
<b>Performance Characteristics</b>	
Safety integrity level	
Safety level degradation	1oo1D, 1oo2D
Safety accuracy	200 $\mu$ A
Self-test interval	< 1 hour, system dependent
Value of least significant bit (control)	0.98 $\mu$ A
Value of least significant bit (monitor)	3.9 $\mu$ A
Error at 25 °C $\pm$ 2 °C	
After 1 year at 40 °C	0.30 % + 10 $\mu$ A
After 2 years at 40 °C	0.35 % + 10 $\mu$ A
After 5 years at 40 °C	0.44 % + 10 $\mu$ A
Temperature drift	(0.01 % + 0.1 $\mu$ A) for each °C
<b>Electrical Characteristics</b>	
Module supply voltage:	
Voltage	Redundant +24 Vdc nominal; 18 Vdc to 32 Vdc range
Module supply power dissipation	3.6 W (12.3 BTU/hr.)
Output voltage:	
Maximum voltage without damage	$\pm$ 60 Vdc
Operating field supply voltage	18 - 32 Vdc
Output current	
Nominal	4 - 20 mA
Maximum range	0.1 - 24 mA
Calibrated accuracy at 25 °C	10 $\mu$ A
Output current control resolution	0.98 $\mu$ A, 15-bit
Output current control accuracy at 25 °C	$\pm$ 10 $\mu$ A
Output current monitoring resolution	3.9 $\mu$ A, 13-bit
Compliance voltage	3 Vdc to 32 Vdc
Maximum Compliance voltage slew rate	No limit identified within Compliance voltage range.
Load impedance	
Maximum range	0 - 750 $\Omega$ limited by compliance voltage
Typical	250 $\Omega$
Maximum field loop power dissipation	0.77 W for each field loop (2.63BTU/hr.)
<b>Mechanical Specification</b>	
Dimensions (height $\times$ width $\times$ depth)	166 mm $\times$ 42 mm $\times$ 118 mm (6-1/2 in. $\times$ 1-21/32 in. $\times$ 4-21/32 in.)
Weight	290 g (10.5 oz.)
Casing	Plastic, non flammable

## T9881/2 Termination Assemblies for Analogue Outputs

T9881 is a simplex 8 channel termination assembly and T882 is the dual termination assembly. Each channel has a capacitor in series with the output.

## T9881/2 Analogue Output Termination Assembly Specification

Table 34 - Analogue Output Module TA Specification

Attribute	Value
<b>Functional Characteristics</b>	
Field connections	8; Wiring: Conductor cross section maximum 1.31 mm <sup>2</sup> (16 AWG); Stripping length 6mm (¼ in.)
Modules supported	T9881: One T9882: Two
<b>Electrical Characteristics</b>	
Channel isolation	± 1.5 kVdc maximum withstand for 1 minute
<b>Mechanical Specification</b>	
Dimensions (height x width)	
T9881	132 mm × 42 mm (5-¼ in. × 1-21/32 in.)
T9882	132 mm × 84 mm (5-¼ in. × 3-5/16 in.)
Weight	
T9881	133 g (5 oz.)
T9882	260 g (10 oz.)



---

## Application (Resource) Development

The AADvance® Workbench environment helps you with the task of automation during the life-cycle of your system, from system design to commissioning and the day to day operation and maintenance. For application (resource) development the AADvance Workbench has powerful, intuitive features and functionality to enhance simplicity.

This chapter introduces the AADvance Workbench and describes basic software features.

### Programming Language Support

The AADvance Workbench is IEC 61131-3 compliant, offering all five languages of the standard:

- Ladder diagram (graphical)
- Function block diagram (graphical)
- Structured text (textual)
- Instruction list (textual)
- Sequential function chart (graphical)

---

**NOTE** Instruction List (IL) and Sequential Function Chart (SFC) languages are not supported by AADvance Workbench 2.0.

---

### Program Management Facilities

The development environment is designed for collaborative working. A group of engineers can work together, with shared ownership of a project. Each contributor can simply look at the part of the application on which they wish to work.

Program management features let you identify each functional module (program organization unit) and its operations, and the interactions between modules to form the complete application. This modular construction can help future use of code units. Engineers can debug their own modules independently from each other.

Programs can be tried and tested on the computer before downloading to the controller hardware.

### Support for Variable Types

For each controller, you can declare variables using all types identified in IEC 61131-3, including Boolean, 16-bit integer (signed and unsigned) and 32-bit real. Controller-specific types include structures to hold multiple variables for each

I/O channel type. Variables are easily imported from external databases if required.

Variables are found in a data dictionary. The development environment supplies a hierarchical tree of variables and a grid-like representation of their definitions.

## I/O Connection (Addressing of Physical I/O)

To show the links between the hardware-independent logical variables of the AADvance application program and the physical I/O channel available on the controller, the AADvance Workbench has a powerful I/O connection editor. I/O channel links are easily identified between the logical programming and the I/O wiring configuration. The I/O configuration can be tested separately from the application execution such that each module can be debugged separately.

Any I/O device can be represented as a single module or a group of redundant modules. Different data types are accommodated. You can work directly on a pre-defined I/O configuration, expand and change the configuration, and the workbench fully supports directly represented I/O variables as described in the IEC 61131-3 standard.

## Off-line Simulation and Testing

An engineer can validate a full application off-line, without the target hardware platform. The powerful simulator within the development environment can do structural and functional tests of each module and of the full application.

## Application (Resource) Program Security

The AADvance controller includes a Program Enable key that protects the application from access that has not been approved for change. The key must be fitted to the KEY connector on the T9100 processor base unit before you can download and make changes to an application (resource). The program enable key is supplied with the processor base unit and is fitted as shown.

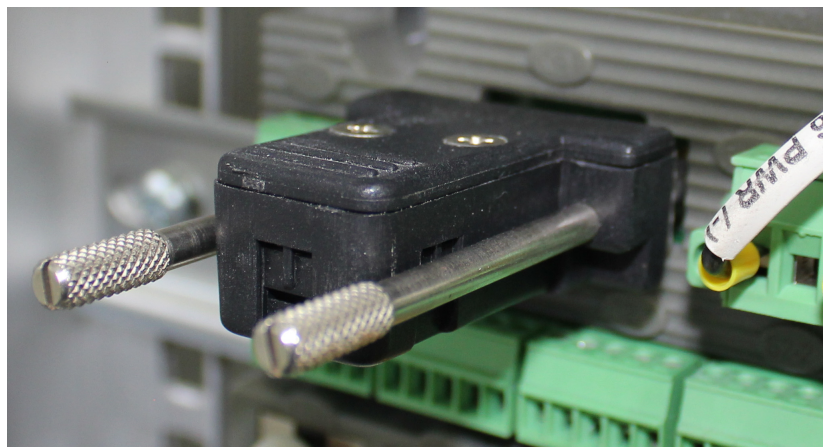

Other security features are available such as password protection at the Workbench and the use of firewall settings.

## Aids to Software Development

The development environment automatically verifies the syntax of the source code entered in each of its supported languages. It performs checks at each stage of development, correcting or prompting the user with the correct use of the language. There is also extensive on-line help, which includes a cross-referenced explanation of the IEC 61131-3 standard.

**Notes:**

## System Build

The AADvance® controller is supplied as an 'open' type equipment, prepared for installation on a wall or panel or inside a cabinet. This chapter gives an overview of a system construction to demonstrate how easy and simple the process can be; refer to the AADvance System Build Manual for more detailed information about constructing a system.

### Controller Mounting

An AADvance controller and I/O bases can be mounted using one of two methods:

- A pair of parallel TS35 DIN rails.
- Panel mounted using three holes on each base.

### Free Space around the Controller

Whichever mounting method is used the minimum depth from the rear mounting panel to the front panel and space around the base units are shown in the illustration, if you wish to mount the controller on DIN rails, increase this allowance by the increased depth of the DIN rails. The DIN rails must be TS35 rail, which is a 35mm × 7.5mm standard symmetric rail.

You must have sufficient free space around the base units to allow for the following:

- Space above, to adjust and install field wiring.
- Space below, to let modules fit and to be able to hold a module during removal.
- Space to the right of the last base unit in the row, to move an I/O base unit during assembly or if you are installing a new base unit.

If an expansion cable is to connect to the left-most base unit, the controller also needs space to the left, to fit the expansion cable adapter.

This illustration shows the minimum recommended clearances for a flat panel or DIN rail mounting.

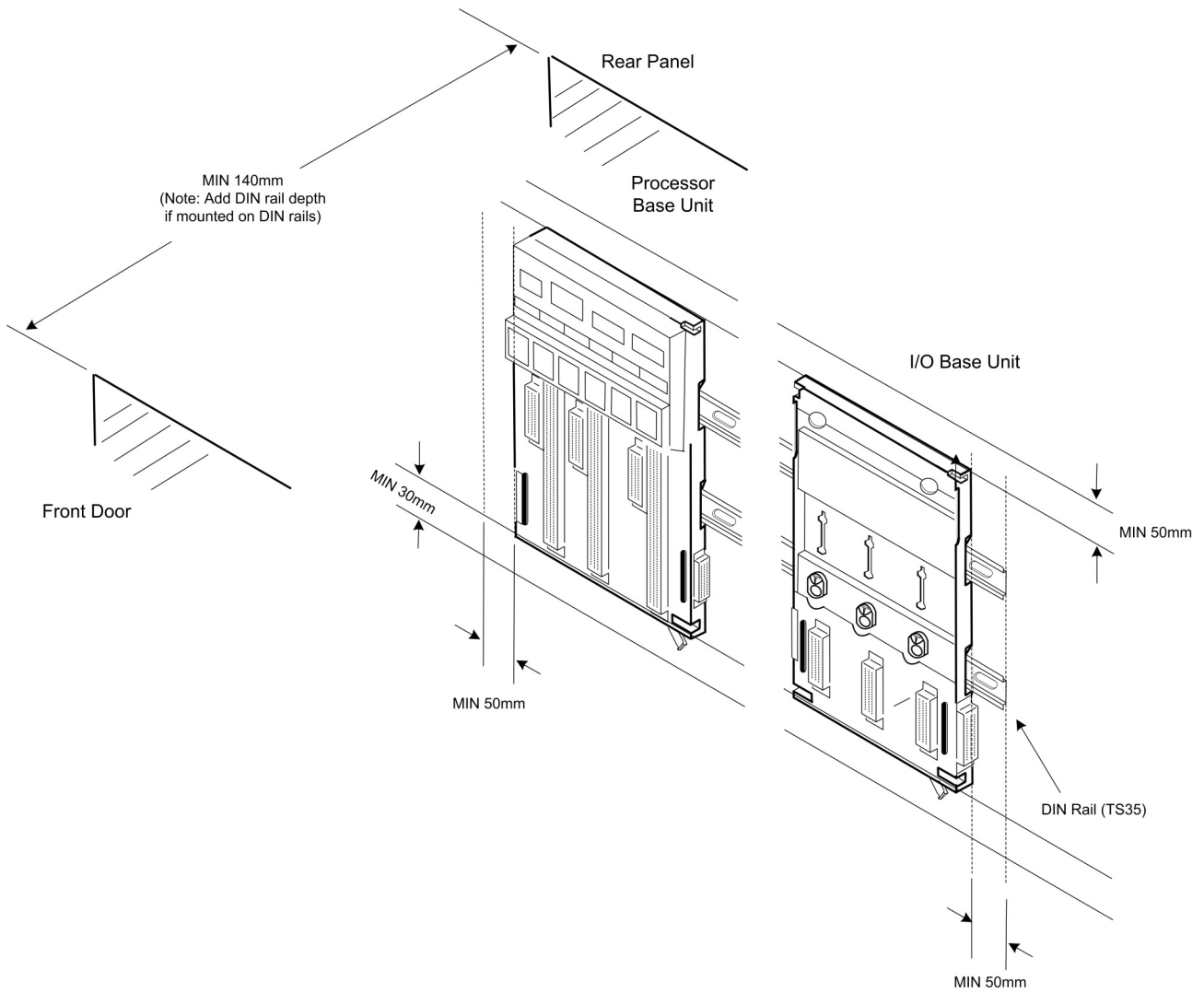

The flat panel drilling holes are shown in the illustration:

**Figure 35 - Flat Panel Mounting**

mm

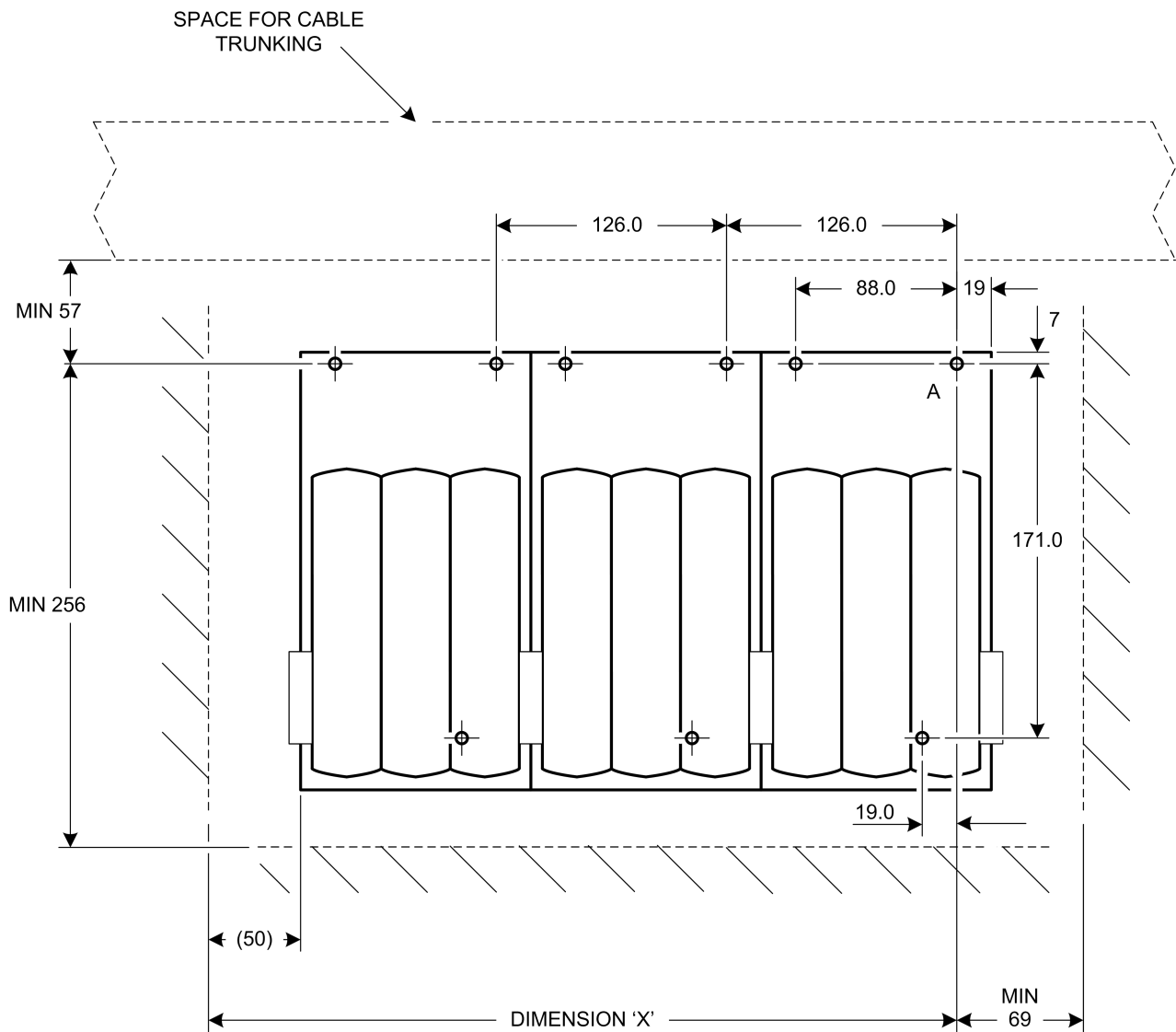

DRILL THREE HOLES PER BASE UNIT, TO SUIT M5 SCREWS

HOLE 'A' IS DATUM

SET DIMENSION 'X' TO SUIT NUMBER OF BASE UNITS:

MIN 157 FOR 1 BASE UNIT

MIN 283 FOR 2 BASE UNITS

MIN 409 FOR 3 BASE UNITS

ADD 126 mm FOR EACH ADDITIONAL BASE UNIT

**CAUTION: HEAT DISSIPATION AND ENCLOSURE POSITION**

The maximum air temperature rating in an enclosure where standard AADvance processor and I/O modules are installed to maintain predictable reliability is 70 °C (158 °F) for I/O modules and 60 °C (140 °F) for processor modules. System and field power consumption by modules and termination assemblies is dissipated as heat. You should consider the effect of heat dissipation on the design and positioning of your enclosure; e.g. enclosures exposed to continuous sunlight will have a higher internal temperature that could increase the operating temperature of the modules. Modules operating at the extremes of the temperature band for a continuous period can have a reduced reliability.

**ATTENTION: DISSIPATION THERMIQUE ET EMBLEMMENT DE L'ENCEINTE**

La température ambiante nominale maximum dans une enceinte où un processeur AADvance et des modules d'E/S standard sont installés pour assurer une fiabilité prévisible, est de 70 °C (158 °F) pour modules d'E/S et de 60 °C (140 °F) pour processeur. La consommation électrique du système et du terrain par les modules et les ensembles de raccordement est dissipée sous forme de chaleur. Vous devez tenir compte de l'effet de la dissipation thermique lors de conception et de disposition de votre enceinte, par exemple, des enceintes continuellement exposées à la lumière solaire auront une température interne plus élevée qui pourrait accroître la température de fonctionnement des modules. La fiabilité des modules fonctionnant aux limites extrêmes de la plage de température pendant une période prolongée peut être réduite.

## Assemblies of Base Units

When base units are installed adjacent to each other they are physically connected by mating connectors and retaining clips so all of the unit forms a single mechanical assembly. Once the base units and termination assemblies have been installed, the insertion and removal of modules will not disturb other electrical connections.

## Base Units Rows and Expansion Cables

AADvance 9300 I/O base units connect to the right hand side of the 9100 processor base unit (I/O Bus 1) and to the right hand side of other 9300 I/O base units by a direct plug and socket connection. The I/O base units connect to the left hand side of the processor base unit by using the 93100 expansion cable (I/O Bus 2). The expansion cable also connects the right hand side of I/O base units to the left hand side of other I/O base units to install extra rows of I/O base units. Base units are secured in place by top and bottom clips that are inserted into the slots on each base unit.



Figure 36 - Connecting Base Units with Expansion Cables

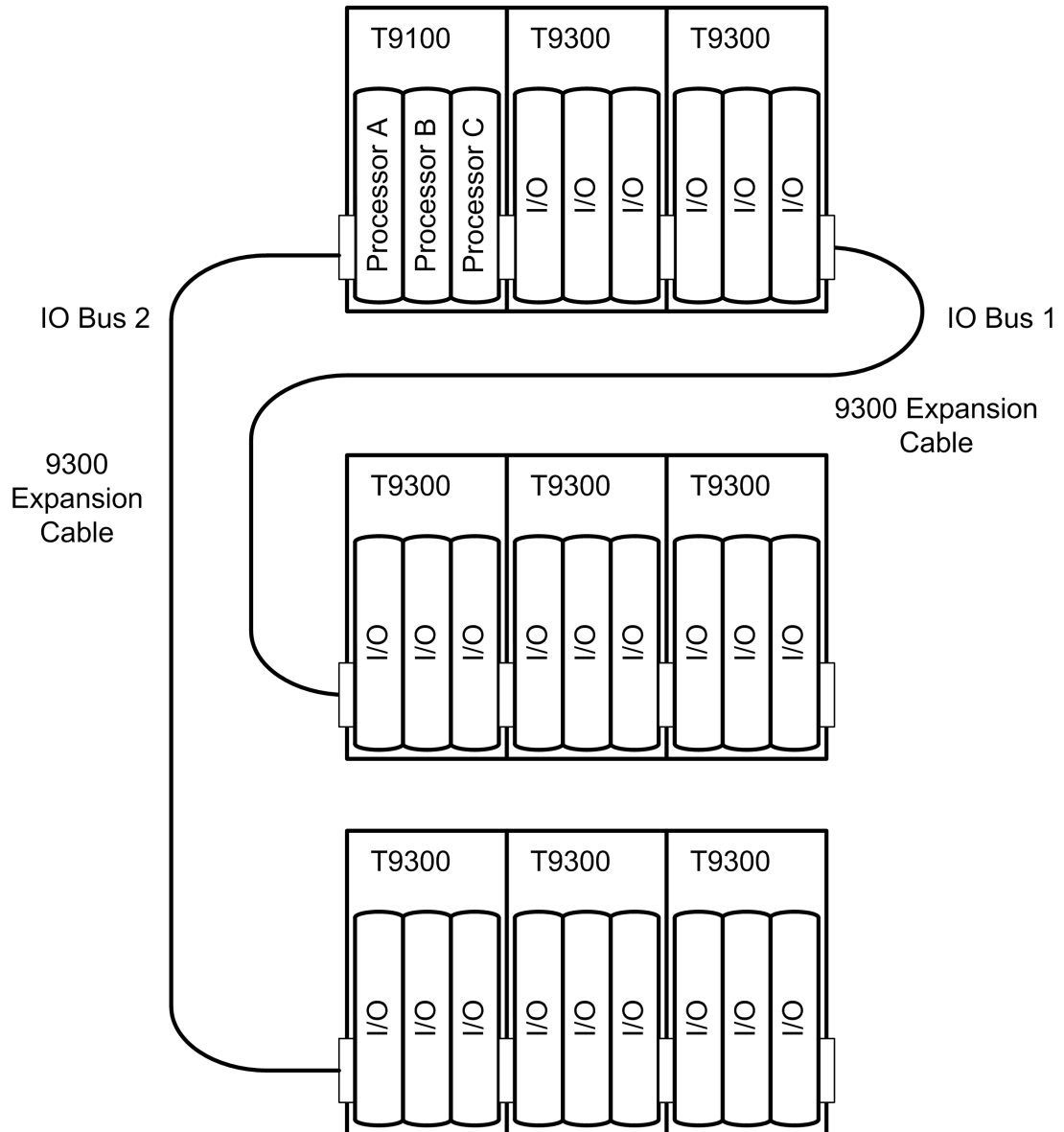

The expansion bus accessed from the right hand edge of the 9100 processor base unit is designated I/O Bus 1, while the bus accessed from the left hand edge is designated I/O Bus 2. The module positions (slots) in the I/O base units are numbered from 01 to 24, the left most position being slot 01. Any individual module position within the controller can thus be uniquely identified by the combination of its bus and slot numbers, for example 1-01.

The electrical characteristics of the I/O bus interface limit the maximum possible length of either of the two I/O buses (the combination of I/O base units and expansion cables) to 8 meters (26.24 ft.).

---

**NOTE** The 9310 Expansion Cable is 2 m (6.56 ft.).

---

## Controller Power Supply Requirements

A controller requires the following power supply sources:

- A dual redundant power supply of + 24 Vdc with an operating range of 18 Vdc to 32 Vdc. The AADvance controller is designed to accept supply transient and interference according to IEC 61131 part 2.

An over current fault in the controller must not cause the system to lose power. Consequently, the power sources must be able to supply the peak current to open any over current protection devices (such as fuses) without failing.

The power supply protection of the controller is in the modules, the power distribution arrangement must have a circuit breaker on the input side of each power source. The controller is designed to be resistant to a reverse polarity connection without permanent damage.

The power sources must come from a commercially available industrial uninterruptible power supply (UPS) system. An applicable UPS must have the capacity sufficient to satisfy the entire system load (including field devices and the controller) and an applicable contingency allowance for projected future expansion.



---

**WARNING:** The power supplies must satisfy the electrical requirements and tests specified in IEC 61131 EN 61010-1 and EN 60950 and must be big enough for the system requirements.

---

## Adding Field Cable Management

The field, power and other system wiring will be connected to terminals along the top of the base units. It is recommended a length of cable trunking or the equivalent be put above each set of base units, for cable management.

Figure 37 - Field Wiring Connections



**Notes:**

## Parts List

### Base Units

Part No.	Part Description
T9100	Processor base unit
T9300	I/O base unit (3 way)

### Modules

Part No.	Part Description
T9110	Processor module
T9401	Digital input module, 24 Vdc, 8 channel, isolated
T9402	Digital input module, 24 Vdc, 16 channel, isolated
T9451	Digital output module, 24 Vdc, 8 channel, isolated, commoned
T9431	Analogue input module, 8 channel, isolated
T9432	Analogue input module, 16 channel, isolated
T9481	Analogue output module, 3 channel, isolated
T9482	Analogue output module, 8 channel, isolated

### Special Application Modules

Part No.	Part Description
T9441	Frequency Input Module (Product not yet released. Contact Sales for more information)

### Termination Assemblies

Part No.	Part Description
T9801	Digital input TA, 16 channel, simplex, commoned
T9802	Digital input TA, 16 channel, dual
T9803	Digital input TA, 16 channel, TMR
T9831	Analogue input TA, 16 channel, simplex, commoned
T9832	Analogue input TA, 16 channel, dual
T9833	Analogue input TA, 16 channel, TMR
T9851	Digital output TA, 24Vdc, 8 channel, simplex, commoned
T9852	Digital output TA, 24Vdc, 8 channel, dual
T9881	Analogue output TA, 8 channel, simplex commoned

Part No.	Part Description
T9882	Analogue output TA, 8 channel, dual
T9844	Frequency Input Module TA, Simplex, Active (not yet released)
T9845	Frequency Input Module TA, Dual, Active (not yet released)
T9846	Frequency Input Module TA, TMR, Active (not yet released)
T9847	Frequency Input Module TA, Simplex, Passive (not yet released)
T9848	Frequency Input Module TA, Dual, Passive (not yet released)
T9849	Frequency Input Module TA, TMR, Passive (not yet released)

## Expansion Cable Assembly

Expansion cable assembly, comprising expansion cable and two adapters

Part No.	Part Description
T9310-02	Backplane expansion cable, 2 meter

## Blanking Covers

Part No.	Part Description
T9191	Blanking cover (tall) for I/O positions with no TA fitted
T9193	Blanking cover (short) for I/O positions with TA or a Processor

## Spares and Tools

Part No.	Part Description
T9901	Replacement input fuse 50 mA for T9801/2/3 and T9831/2/3, pack of 20 <sup>(1)</sup>
T9902	Replacement output fuse 10A for T9851/2, pack of 20 <sup>(2)</sup>
T9903	Replacement coding pegs (pack of 20)
T9904	Replacement backplane clips (pack of 20)
T9905	Replacement processor 3 V lithium cell, pack of 20 <sup>(3)</sup>
T9906	Replacement program enable key
T9907	Installation tool kit
T9908	Fuse Extractor Tool

(1) T9901: No 396/TE5 50 mA time lag fuse; UL 248-14, 125 V, Leadfree; manufactured by Littelfuse.

(2) T9902: SMF Omni-Block, Surface Mount Fuse Block 154 010, with a 10 A, 125 V Fast Acting Fuse, Littelfuse.

(3) T9905: Polycarbon monofluoride Lithium Coin Battery, BR2032, 20 mm dia; Nominal voltage 3 V; Nominal capacity (mAh) 190; Continuous standard load (mA) 0.03; Operating temperature -30 °C to +80 °C, supplied by Panasonic.

## Software

Part No.	Part Description
T9082U	IEC 61131 Workbench, USB key, single user, single controller
T9082D	IEC 61131 Workbench, hard disk key, single user, single controller
T9083U	IEC 61131 Workbench, USB key, multiple controllers
T9083D	IEC 61131 Workbench, hard disk key, multiple controllers
T9084U	IEC 61131 Workbench, 5 user USB key, multiple controllers
T9085	5 additional user licences, for use with T9084U

Part No.	Part Description
T9087	IEC 61131 Workbench 2
T9030	OPC portal server
T9033	AADvance® DTM (for use with HART Pass-Through feature)

## Demonstration Unit

Part No.	Part Description
T9141	AADvance Demonstration Unit (Including HMI)

## Miscellaneous Items

Part No.	Part Description
----------	------------------

**Notes:**



## History of Changes

This appendix contains the new or updated information for each revision of this publication. These lists include substantive updates only and are not intended to reflect all changes. Translated versions are not always available for each revision.

### ICSTT-RM447N-EN-P, February 2021

---

#### Change

---

Updated for AADvance® system release 1.40 TÜV Rheinland certification.

---

Updated AADvance system release version number in the AADvance Release section.

---

Added AADvance®-Trusted® SIS Workstation Software User Guide, publication ICSTT-UM002, to the Additional Resources section.

---

Applied latest publication template.

---

Updated Vibration specification in Environmental Specification section.

---

Updated **proof test** definition and added **mission time** definition in Glossary.

---

### ICSTT-RM447M-EN-P, July 2019

---

#### Change

---

Updated for Release 1.34 IEC 61508 Edition 2.0 certification

---

### ICSTT-RM447L-EN-P, April 2018

---

#### Change

---

Release 1.40 updates.

---

### Issue 12, June 2015

---

#### Change

---

Correct Issue Record

---

### Issue 11, March 2015

---

#### Change

---

Release 1.34 updates

---

### Issue 10, July 2014

---

#### Change

---

Release 1.33 updates

---

### Issue 09, June 2013

---

#### Change

---

Changes to TUV certification topic, add on-line update feature and module specification data.

---

**Issue 08, July 2012**

---

**Change**

---

Release 1.3 version

---

**Issue 07, November 2010**

---

**Change**

---

Updates for ATEX and UL Certification and release 1.2

---

**Issue 06, October 2010**

---

**Change**

---

Updates to meet UL requirements

---

**Issue 05, June 2010**

---

**Change**

---

Updates for release 1.1.1

---

**Issue 04, March 2010**

---

**Change**

---

Updates after peer review

---

**Issue 03, February 2010**

---

**Change**

---

**Issue 02, February 2009**

---

**Change**

---

**Issue 01, December 2008**

---

**Change**

---

First issue

---

The following terms and abbreviations are used throughout this manual. For definitions of terms not listed here, refer to the Allen-Bradley Industrial Automation Glossary, publication [AG-7.1](#).

### A

- accuracy** The amount of closeness of a measurement of a quantity to the true value of the quantity. See also 'resolution'.
- achievable safe state** A safe state that is achievable.
- Sometimes, a safe state cannot be achieved. An example is a non-recoverable fault such as a voting element with a shorted switch and no means to bypass the effect of the short.
- actuator** A device causing an electrical, mechanical, or pneumatic action to occur in a plant component. Examples are valves and pumps.
- AITA** Analogue input termination assembly.
- alarms and events (AE)** An OPC data type providing time-stamped alarm and event notifications.
- allotted process safety time** The part of the total process safety time allotted to a sub function of a process.
- application software** Software written specially for a user application, typically using logic sequences, limits and expressions to read inputs, make decisions and control outputs for a specified system.
- architecture** Organizational structure of a computing system describing the functional relationship between board level, device level and system level components.
- asynchronous** A data communications term describing a serial transmission protocol. A start signal is sent before each byte or character and a stop signal is sent after each byte or character. An example is ASCII over RS-232-C. See also 'RS-232-C, RS-422, RS-485'.
- availability** The probability that a system can do its specified functions when required for use. Normally expressed as a percentage.

### B

- backplane clip** A sprung, plastic device to holding together two adjacent AADvance® base units. Part number 9904. Used in pairs.
- base unit** One of two designs making the supporting parts of an AADvance controller. See 'I/O base unit' and 'processor base unit'.

- 
- binding** A relationship between two variables in different AADvance controllers. One variable is a producer and the other is a consumer. The system updates the value in the consumer to match the data in the producer. See 'SNCP protocol'.
- black channel** A path for communications data which does not maintain the integrity of the data transferred over it. Measures to find and compensate for errors introduced by the black channel are implemented by software or hardware (or both) in the safety critical sender and receiver.
- blanking cover** A plastic moulding to hide an empty slot in an AADvance controller base unit.
- Boolean** A type of variable that can only accept only the values 'true' and 'false'.
- BPCS** Basic process control system. A system responding to input signals and generating output signals causing a process and its related equipment to operate in a desired way, having no safety instrumented functions with a safety integrity level of 1 or higher. See IEC 61511 and ANSI/ISA—84.00.01—2004 Part 1 (IEC 61511-1 Mod) for a formal definition. Equivalent to the Process Control System (PCS) specified by IEC 61508.
- breakdown voltage** The maximum voltage (AC or DC) that can be continuously applied between isolated circuits without failure of the insulation.
- BS EN 54** A standard for fire detection and fire alarm systems.
- BS EN 60204** A standard for the electrical equipment of machines, which promotes the safety of persons and property, consistency of control response and to make maintenance easy.
- bus** A group of conductors for related data. Typically allocated to address, data and control functions in a microprocessor-based system.
- bus arbitration** A mechanism for deciding which device has control of a bus.

## C

- CIP** Common Industrial Protocol. A communications protocol created by Rockwell Automation for the Logix controller family, and supported by the AADvance controller. AADvance controllers use the protocol to send data to and from Logix controllers using a consumer/producer model. It can also be used to communicate data between AADvance controllers.
- clearance** The shortest distance in air between two conductive parts.
- coding peg** A polarizing key, fitted to the 9100 processor base unit and to each termination assembly ensuring that only a module having the correct type can be fitted in a slot. Part number 9903.
- coil** In IEC 61131-3, a graphical component of a Ladder Diagram program representing the assignment of an output variable. In MODBUS language, a discrete output value.

- 
- Compiler Verification Tool (CVT)** A software utility that validating a compiled application to look for errors introduced by the Workbench or the compiler. Frequently abbreviated to CVT.
- configuration** A grouping of the application software and settings for a specified AADvance controller. The grouping must have a 'target', but for an AADvance controller it can have only one 'resource'.
- consumer** The consuming controller requests the tag from the producing controller.
- contact** A graphical component of a Ladder Diagram program representing the status of an input variable.
- continuous mode** Where the Safety Instrumented Function in the safety system is continually maintaining the process in a safe condition.
- controller** A logic solver. The combination of application execution engine and I/O hardware.
- controller system** One or more controllers, their power sources, communications networks and workstations.
- coverage** The percentage of faults that are detected by automated diagnostics. See also 'SFF'.
- creepage distance** The shortest distance along the surface of an insulating material between two conductive parts.
- cross reference** Information calculated by the AADvance Workbench relating to the dictionary of variables and where those variables are used in a project.

## D

- data access (DA)** An OPC data type providing real-time data from AADvance controllers to OPC clients.
- de-energize to action** An output circuit for a safety instrumented function where the field device is usually energized. Removal of power de-activates the device.
- dictionary** The set of internal input and output variables and defined words used in a program.
- discrepancy** A condition that exists if one or more elements disagree.
- DITA** Digital input termination assembly.
- DOTA** Digital output termination assembly.

## E

- element** A set of input conditioning, application processing and output conditioning.

- 
- energize to action** An output circuit for a safety instrumented function where the devices are usually de-energized. Application of power activates the field device.
- EUC** Equipment under control. The machinery, apparatus or plant used for manufacturing, processing, transportation, medical or other activities.
- expansion cable assembly** A flexible interconnection carrying bus signals and power supplies between AADvance base units, available in a variety of lengths. Used with a cable socket assembly (at the left side of a base unit) and a cable plug assembly (at the right side of a base unit).

## F

- fail operational state** A condition where a fault has been masked. See 'fault tolerant'.
- fail safe** The ability to go to a pre-determined safe condition when a specified malfunction occurs.
- fault reset button** The momentary action push switch on the front panel of the 9110 processor module.
- fault tolerance** The ability of a system to operate correctly with a specified number of hardware and software faults.
- fault tolerant** The ability of a system to accept the effect of one arbitrary fault and continue correct operation.
- fault warning receiving station** A location where corrective measures can be initiated.
- fault warning routing equipment** Equipment which routes a fault warning signal from control and indicating equipment to a fault warning receiving station.
- field device** An item of equipment connected to the field side of the I/O terminals. Such equipment includes field wiring, sensors, final control elements and operator interface devices which are hard-wired to I/O terminals.
- fire alarm device** A component of a fire alarm system, not incorporated in the control and indicating equipment which is used to give a warning of fire — for example a sounder or visual indicator.
- fire alarm receiving station** A location from which fire protection or firefighting measures can be initiated.
- fire alarm routing equipment** Equipment which routes an alarm signal from control and indicating equipment to a fire alarm receiving station.
- function block diagram** An IEC 61131 language describing a function between input variables and output variables. Input and output variables are connected to blocks by connection lines. See 'limited variability language'.
- functional safety** The ability of a system to perform the actions necessary to achieve or to maintain a safe state for a procedure and its related equipment.

---

## G

**group** A collection of two or three input modules (or two output modules), arranged together to supply enhanced availability for their input or output channels.

## H

**hand-held equipment** Equipment which is intended to be held in one hand while being operated with the other hand. See 'portable equipment'.

**HART** Highway Addressable Remote Transducer. An open protocol for process control instrumentation. It combines digital signals with analogue signals to give control and status data for field devices. For more details about HART devices refer to the HART Application Guide, created by the HART Communication Foundation, and the full HART specifications. You can download documents from [www.hartcomm.org](http://www.hartcomm.org).

**high demand mode** Where the Safety Instrumented Function in the safety system only performs its designed task on a demand, and the frequency of demands is more than one time each year.

**hot swap** See 'live insertion'.

## I

**I/O base unit** A backplane assembly holding one, two, or three I/O modules and their related termination assembly or assemblies in an AADvance controller. Part number 9300. See 'I/O module' and 'termination assembly'.

**I/O module** An AADvance module continuing interfaces for inputs from field sensors and generating output for field elements. Connects to the field through Termination Assemblies and to the processor across I/O bus connections.

**IEC 61000** A series of international standards providing techniques for testing and measuring electromagnetic compatibility.

**IEC 61131** An international standard defining programming languages, electrical parameters and environmental conditions for programmable logic controllers. Part 3, which is entitled 'Programming Languages', defines more than one limited variability language.

**IEC 61499** An international standard defining an open architecture for distributed control and automation.

**IEC 61508** An international standard for functional safety, encompassing electrical, electronic and programmable electronic systems; hardware and software aspects.

---

**IEC 61511** An international standard for functional safety and safety instrumented systems for the process industry, encompassing electrical, electronic and programmable electronic systems, hardware and software aspects.

**indicator** A device whose state can change to provide data.

**input (AADvance Workbench variable)** In the context of an AADvance Workbench variable, a quantity passed to the Workbench from a controller.

**instruction list** An IEC 61131 language, almost the same as the simple textual language of PLCs. See 'limited variability language'.

**integer** A variable type specified by the IEC 61131 standard.

**IXL** ISaGRAF® eXchange Layer. The protocol for communications between ISaGRAF-based components.

## K

**key connector** The receptacle on the AADvance controller for the program enable key. A 9-way 'D' type socket on the 9100 processor base unit.

## L

**ladder diagram** An IEC 61131 language composed of contact symbols representing logical equations and actions. The main function is to control outputs based on input conditions. See 'limited variability language'.

**LAN** Local area network. A computer network covering a small physical area, characterized by a small geographic range having no need for leased telecommunication lines.

**live insertion** The removal and then reinsertion of an electronic module into a system while the system remains powered. The assumption is that removal of the module and reinsertion will cause no electrical harm to the system. Also known as 'hot swap'.

**low demand mode** Where the Safety Instrumented Function only performs its designed task on demand, and the frequency of demands is no more than one time each year.

## M

**manual call point** A component of a fire detection and fire alarm system enabling a person to trigger an alarm.

**mission time** The time that the SIF (Safety Instrumented Function) is designed to be operational.



---

**MODBUS** An industry standard communications protocol developed by Modicon. Used to communicate with external devices such as distributed control systems or operator interfaces.

**MODBUS object** A representation of the configuration settings for a MODBUS Master or for its related slave links, in the AADvance Workbench. The settings include communication settings and messages.

**module clamp screw** The AADvance latch mechanism seen on the front panel of each module and operated by a broad, flat-blade screwdriver. Uses a cam action to hold the module to its base unit.

## N

**NFPA 85** The Boiler and Combustion Systems Hazards Code. Applies to some boilers, stokers, fuel systems, and steam generators. The code helps to prevent uncontrolled fires, explosions and implosions.

**NFPA 86** A standard for ovens and furnaces. Provides the requirements for the prevention of fire and explosion hazards related to heat processing of materials in ovens, furnaces and related equipment.

## O

**on-line** The condition of a controller that executes the application software.

**OPC** A series of standards specifications for open connectivity in industrial automation.

**output (Workbench variable)** In the context of an AADvance Workbench variable, this term describes a quantity passed from the Workbench to a controller.

## P

**peer to peer (network)** One or more Ethernet networks connecting together a series of AADvance or Trusted® controllers enabling application data to pass between them.

**pinging** In MODBUS communications, sending the diagnostic Query Data command over a link and by receiving a reply to verify that the link is healthy and the slave can communicate with the master. No process data is transferred or modified.

**portable equipment** Enclosed equipment that is moved while in operation or which can easily be moved from one location to a different location while connected to the power supply. Examples are programming and debugging tools and test equipment. See 'hand held' equipment.

- processor base unit** A backplane assembly holding all of the processor modules in an AADvance controller. Part number 9100. See also 'processor module'.
- processor module** The application execution engine of the AADvance controller, housed in a self-contained and standardized physical enclosure.
- producer** A controller producing a tag to one or more consumers. The controller produces a tag when a consumer asks for one.
- program enable key** A security device that permitting access to the application in an AADvance controller. Part number 9906. Supplied with the processor base unit. See also 'key connector'.
- project** A collection of configurations and the definition of the linking between them. See 'configuration'.
- proof test** A periodic test performed to detect dangerous hidden faults in a safety instrumented system (SIS) so that, if necessary, a repair can restore the system to an 'as new' condition or as close as practical to this condition.
-  Proof tests are designed to reveal both Systematic and Random failures, Proof tests may be required depending on how the technology has been implemented.
- AADvance product data is given for a Useful Life of 20 years. For a Mission Time of up to 20 Years, proof testing is not required. For Mission Times greater than 20 years, any products that are still in service once that time is reached should be replaced.
- protocol** A set of rules that is used by devices (such as AADvance controllers, serial devices and engineering workstations) to communicate with each other. The rules encompass electrical parameters, data representation, signaling, authentication, and error detection. Examples include MODBUS, TCP and IP.
- PST** Process Safety Time. The process safety time for the equipment under control (denoted PSTEUC) is the length of time a dangerous condition can exist before a hazardous event occurs without a safety system as a protection.

## R

- real** A class of analogue variable stored in a floating, single-precision 32-bit format.
- redundancy** The use of two or more devices, each performing the same function, to increase reliability or availability better.
- resolution** The smallest value measurable by an instrument; the level of detail which can be represented. For example, 12 bits can distinguish between 4096 values.
- RS-422, RS-485** Standard interfaces introduced by the Electronic Industries Alliance covering the electrical connection between data communication equipment.
- RTC** Real-time clock.

---

**RTU** Remote terminal unit. The MODBUS protocol supported by the AADvance controller for MODBUS communications over serial links, with the ability to multi-drop to multiple slave devices.

## S

**safe state** A condition which permitting the execution of a process demand. Usually entered after the detection of a fault condition, ensuring that the effect of the fault is to enable rather than disable a process demand.

**safety accuracy** The accuracy of an analogue signal in which the signal is guaranteed to have no dangerous faults. If the signal drifts outside this range, it is declared faulty.

**safety-critical state** A faulted condition preventing the execution of a process demand.

**sensor** A device (or a combination of devices) that measures a process condition. Examples are transmitters, transducers, process switches and position switches.

**sequential function chart** An IEC 61131 language dividing the process cycle into a number of specified steps separated by transitions. See 'limited variability language'.

**SFF** Safe Failure Fraction. Given by (the total rate of safe failures plus the rate of detected dangerous failures) divided by (the total rate of safe failures plus the rate of detected and undetected dangerous failures).

**SIF** Safety Instrumented Function. A type of process control performing specified functions to get (or maintain) a safe state of a process when unacceptable or dangerous process conditions are detected.

**SIL** Safety Integrity Level. One of four possible levels, specified in IEC 61508 and IEC 61511, for specifying the performance requirements of the safety functions allocated to a safety-related system. SIL4 has the highest level of safety integrity, SIL 1 has the lowest. For an installation to get a specified SIL rating, all of the parts of the installation (together with the AADvance controller) must fulfill these requirements.

**SNCP** Safety Network Control Protocol. A set of rules that allowing different AADvance controllers in a system to share data. SNCP is a SIL 3 certified protocol which provides a safety layer for an Ethernet network.

**SNTP** Simple Network Time Protocol. A set of rules for synchronizing the real-time clocks of AADvance controllers and other devices over Ethernet networks.

**structured text** A high level IEC 61131-3 language with syntax equivalent to that of Pascal. Useful for making complex procedures that cannot be expressed easily with graphical languages.

**synchronous** A data communications term describing a serial transmission protocol. A pre-arranged number of bits is expected to be sent across a line each second. To synchronize the sending and receiving machines, a clocking signal is sent by the transmitting computer. There are no start or stop bits.

---

## T

**TA** See 'termination assembly'.

**target** An attribute of a 'configuration' which describes characteristics of the AADvance controller on which the configuration will run. Includes characteristics such as the memory model and the sizes of variable types for the controller.

**TCP** Transmission control protocol. A set of rules used by applications requiring guaranteed delivery of a stream of bytes from a program found on one computer to a different program, typically found on a different computer. An example for an AADvance controller is MODBUS communications over Ethernet. One of the core protocols of the Internet Protocol suite.

**termination assembly** A printed circuit board connecting field wiring to an input or output module. The circuit includes fuses for field circuits. The board carries screw terminals to connect the field wiring to the controller, and the whole assembly clips onto the 9300 I/O base unit.

**TMR** Triple modular redundant. A fault-tolerant arrangement in which three systems complete a process and their result is processed by a voting system to provide one output.

## U

**U** Rack unit. A unit of measure used to give the height of equipment intended for mounting in a standard rack. Equivalent to 44.45 mm (1-¾ inches).

## V

**validation** In quality assurance, approval that the product does what the user requires.

**verification** In quality assurance, approval that the product conforms to the specifications.

**voting system** A redundant system (m out of n) requiring at least m of the n channels to be in agreement before the system can take action.

## W

**withstand voltage** The maximum voltage level that can be applied between circuits or components without causing a failure of the insulation.

**word** A 16-bit unsigned value from 0 to 65535. One of the IEC 61131 types. See also 'integer'



# Rockwell Automation Support

Use these resources to access support information.

<b>Technical Support Center</b>	Find help with how-to videos, FAQs, chat, user forums, and product notification updates.	<a href="http://rok.auto/support">rok.auto/support</a>
<b>Knowledgebase</b>	Access Knowledgebase articles.	<a href="http://rok.auto/knowledgebase">rok.auto/knowledgebase</a>
<b>Local Technical Support Phone Numbers</b>	Locate the telephone number for your country.	<a href="http://rok.auto/phonesupport">rok.auto/phonesupport</a>
<b>Literature Library</b>	Find installation instructions, manuals, brochures, and technical data publications.	<a href="http://rok.auto/literature">rok.auto/literature</a>
<b>Product Compatibility and Download Center (PCDC)</b>	Download firmware, associated files (such as AOP, EDS, and DTM), and access product release notes.	<a href="http://rok.auto/pcdc">rok.auto/pcdc</a>

## Documentation Feedback

Your comments help us serve your documentation needs better. If you have any suggestions on how to improve our content, complete the form at [rok.auto/docfeedback](http://rok.auto/docfeedback).

## Waste Electrical and Electronic Equipment (WEEE)



At the end of life, this equipment should be collected separately from any unsorted municipal waste.





Rockwell Automation maintains current product environmental information on its website at [rok.auto/pec](http://rok.auto/pec).

AADvance, Allen-Bradley, ControlFLASH, ControlLogix, expanding human possibility, ICS Triplex, ISAGRAF, Rockwell Automation, Rockwell Software, RSLinx, TechConnect, and Trusted are trademarks of Rockwell Automation, Inc.

EtherNet/IP is a trademark of ODVA, Inc.

Trademarks not belonging to Rockwell Automation are property of their respective companies.

Rockwell Otomasyon Ticaret A.Ş. Kar Plaza İş Merkezi E Blok Kat:6 34752, İçerenköy, İstanbul, Tel: +90 (216) 5698400 EEE Yönetmeliğine Uygundur

Connect with us.    

**rockwellautomation.com** ————— **expanding human possibility™**

AMERICAS: Rockwell Automation, 1201 South Second Street, Milwaukee, WI 53204-2496 USA, Tel: (1) 414.382.2000, Fax: (1) 414.382.4444

EUROPE/MIDDLE EAST/AFRICA: Rockwell Automation NV, Pegasus Park, De Kleetlaan 12a, 1831 Diegem, Belgium, Tel: (32) 2 663 0600, Fax: (32) 2 663 0640

ASIA PACIFIC: Rockwell Automation, Level 14, Core F, Cyberport 3, 100 Cyberport Road, Hong Kong, Tel: (852) 2887 4788, Fax: (852) 2508 1846

Publication ICSTT-RM447N-EN-P - February 2021

Supersedes Publication ICSTT-RM447M-EN-P - July 2019

Copyright © 2021 Rockwell Automation, Inc. All rights reserved.