



8720SM High Performance AC Induction Motors

(Catalog Number 8720SM-xxxxxxxSx)

Introduction

This publication provides installation instructions for the 8720SM motors. Use this document if you are responsible for the design and installation of 8720SM motors. Refer to the *8720MC High Performance Drive Integration Manual* (publication 8720MC-IN002x-EN-P) for performance information.

For:	See page:
Complying with European Union Directives	2
8720SM AC Motor Overview	3
8720SM Receiving and Storage Information	4
Before Mounting Your Motor	5
Building Your 8720SM Motor Cables	7
Guidelines for Installing Your Motor	8
Wiring Your 8720SM Motor Power	9
Blower Motor	13
Motor Operation and Maintenance	15
Specifications	16
Dimensions	18
Motor Load Force Ratings	25

Complying with European Union Directives

If this product is installed within the European Union or EEC regions and has the CE mark, the following regulations apply.

EMC Directive

This unit is tested to meet Council Directive 89/336/EEC Electromagnetic Compatibility (EMC) using the following standards, in whole or in part:

- EN 50081-2 EMC - Emission Standard, Part 2 - Industrial Environment
- EN 50082-2 EMC - Immunity Standard, Part 2 - Industrial Environment
- EN 61800-3 - Adjustable Speed Electrical Power Drive Systems, Part 3 - EMC Product Standard including specific test methods

The product described in this installation instructions is intended for use in an industrial environment.

Low Voltage Directive

These units are tested to meet Council Directive 73/23/EEC Low Voltage Directive. The EN 60204-1 Safety of Machinery-Electrical Equipment of Machines, *Part 1-Specification for General Requirements* standard applies in whole or in part.

8720SM AC Motor Overview

The 8720SM motors are high performance AC induction motors specifically designed for use with the Allen-Bradley 8720MC Drives. Refer to the configurator below to help identify your 8720SM motor.

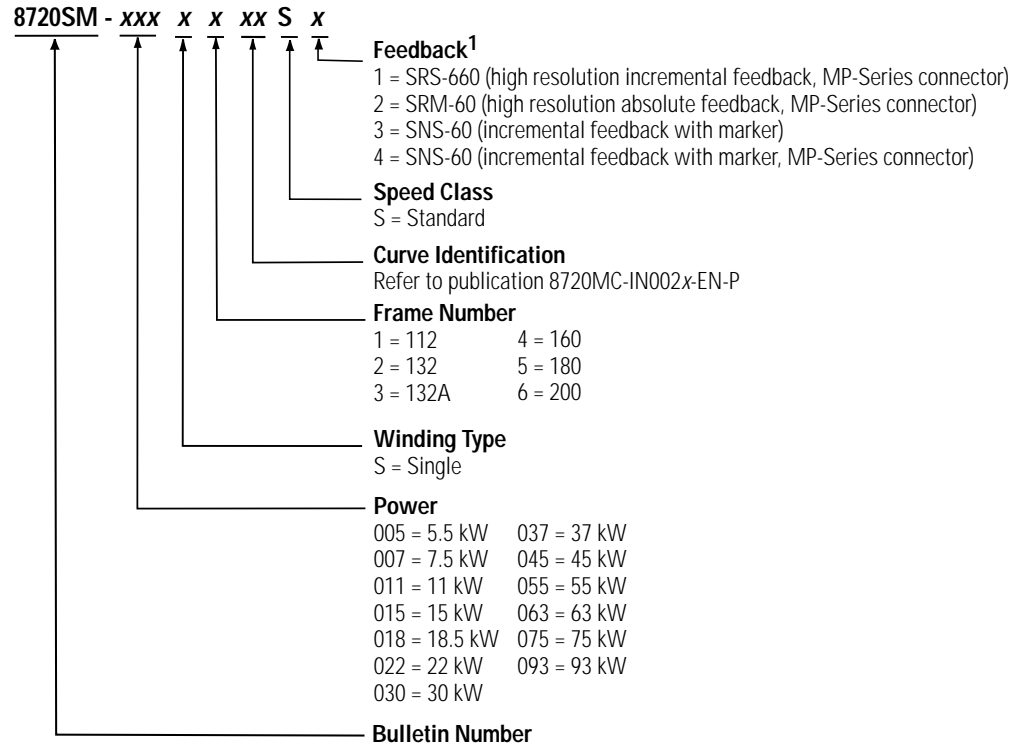

¹ Feedback options 1 and 2 apply to SERCOS mode applications. Feedback options 3 and 4 apply to Analog mode applications.

Refer to the following table to compare the motor frame number to the motor catalog number.

Frame	Catalog Number (8720SM)
DL1106	-005S1BASx, -005S1BBSx, -005S1BCSx
DL1108	-007S1CASx, -007S1CBSx, -007S1CCSx
DL1110	-011S1DASx, -011S1DBSx, -011S1DCSx
RDL1307	-015S2EASx, -015S2EBSx, -015S2ECSx
RDL1308	-018S2FASx, -018S2FBSx
RDL1310	-022S2GASx
RDL1611	-030S4JASx
RDL1613	-037S4KASx
DL1811	-045S5NASx
DL1813	-055S5PASx
DL1815	-063S5QASx
DL2010	-075S6SASx
DL2012	-093S6TASx

8720SM Receiving and Storage Information

The customer is responsible for inspecting the equipment before accepting the shipment from the freight company. Check the items against your purchase order.

Handling

The 8720SM motors are equipped with lifting eye bolts. These eye bolts are provided to assist in handling and mounting the motors. The motors can accommodate either flange or foot mount.

ATTENTION

Eyebolts may unscrew during lifting. Check the eyebolts to insure that they are tight. Failure to observe this precaution could result in bodily injury.

Storage

Store motors in a clean, dry area protected from extreme temperatures, moisture, shock, and vibration. Observe storage temperatures of -20° to 80° C (-4° to 176° F) with a relative humidity of 5 to 95%.

IMPORTANT

All drains are fully operable while in storage. Store motors so that the drain is at the lowest point. Drains are located in the lower portion of the motor castings on both the drive and non-drive ends of the motor.

ATTENTION

Only qualified electrical personnel familiar with the construction and operation of this equipment and the hazards involved should install, adjust, operate, and/or service this equipment. Read and understand this document in its entirety before proceeding. Failure to observe this precaution could result in severe bodily injury or loss of life.

The application of motors and other electrical equipment in hazardous locations is restricted by the National Electric Code. To ensure compliance, observe these regulations and consult with local code inspection and enforcement agencies.

Before Mounting Your Motor

Before mounting your 8720SM motor, consider the following:

- You can mount the motor horizontally or vertically with the shaft down or up.
- The 8720SM motors are blower cooled with air flow from the blower end to the drive end. The air flow must be flowing in the direction of the arrow on the motor to provide adequate cooling. Both air inlets and outlets must be free of obstructions. Maintain a clearance of at least 100 mm (4 in.) at the blower inlet area.
- When mounted, the motor must *not* be exposed to direct splash or spray of cutting fluids or lubricating oils.
- Motors include a labyrinth type shaft seal with flinger, which helps protect against splashing. However, it will not provide protection against flooding.
- In an environment where high humidity is present or the motor blower inlet air is saturated with coolant mist, make sure the motor is mounted with the feet down and the drain holes at the bottom of the motor are open.
- The motors are designed for the ambient temperature indicated on the nameplate. The standard motor maximum ambient is 40° C (104° F). Locate the motor where the ambient temperature requirements are satisfied and where clean air has free access to ventilating intake and outlet openings. Except for machines with a suitable protective enclosure, the location should be clean and dry.

IMPORTANT

The cooling system on standard 8720SM blower cooled motors requires that clean air is forced through ducts which are integral to the stator frame. It is important that you keep these air passages clean and that sufficient clearance is provided on the motor air inlets and stator duct outlets for unrestricted air flow.

ATTENTION

You must be careful to prevent debris (such as metal shavings and conduit knockouts) from falling into the motor while performing any installation work around the motor. A hazard of personal injury and/or equipment damage exists if foreign material lodges inside the motor.

Using Belted Drives and Coupled Drives

Proper alignment is key for long life of bearings, shafts and belts, and minimum downtime.

Belted Drives

If you use motor slide bases or rails, you must securely anchor them to the foundation with the proper bolts. Make sure the motor shaft and load shaft are parallel, and that the sheaves are aligned.

When a motor is belt coupled, the belt tension must not exceed the radial load capabilities of the motor bearings. For belt drives, place the sheave as close as possible to the motor bracket. The maximum allowable radial load is assumed to be applied at the end of the motor drive shaft.

IMPORTANT

Do not exceed the maximum allowable radial load on the end of the shaft. Refer to the *Radial Load Force Ratings (Zero Axial Load)* on page 25 for a listing of radial loads.

Coupled Drives

Use flexible couplings between the motor shaft and the load shaft. Align the motor shaft and the load shaft to values recommended for the specific coupling before coupling is connected.

IMPORTANT

Do not exceed the maximum allowable axial load on the end of the shaft. Refer to the *Axial Load Force Ratings (Zero Radial Load)* on page 26 for a listing of axial loads.

Balancing the Motor

Misalignment can cause excessive vibration and damaging forces to the shaft and bearings. During high speed operation, a small unbalance can cause significant vibration. Make sure to accurately dynamically balance any gears, pulleys, or couplings that are mounted to the motor shaft. Best results are obtained by balancing after the device is mounted to the shaft.

Motors are dynamically balanced to stay within a vibration limit of 0.12 in./s, measured in accordance with NEMA MG-12.06. Balance is done with a full length 1/2 height shaft key. A full shaft key is shipped

with the motor. Sheave or coupling should be balanced with a 1/2 height shaft key.

Preventing Electrical Noise

Use Electromagnetic Compatibility (EMC) techniques to reduce Electromagnetic Interference (EMI), commonly called noise. Noise adversely impacts motor performance by inducing stray signals. Effective techniques to counter EMI include filtering the AC power, shielding and separating signal carrying lines, and practicing good grounding techniques.

To help avoid EMI:

- Filter AC power by using isolated AC power transformers or properly installed AC line filters.
- Physically separate signal lines from motor cabling and power wiring. Do not route signal wires with motor and power wires, or over the vent openings of servo drives.
- Ground all equipment using a single-point parallel ground system that employs ground bus bars or large straps.

Refer to *System Design for Control of Electrical Noise Reference Manual* (GMC-RM001x-EN-P) for information on additional electrical noise reduction techniques.

Building Your 8720SM Motor Cables

Proper cable construction and routing improves system ElectroMagnetic Compatibility (EMC). Refer to the *8720MC High Performance Drive Installation Manual* (publication 8720MC-IN001x-EN-P) for information regarding cable construction.

Guidelines for Installing Your Motor

Observe the following for installing your motor:

ATTENTION

Only qualified electrical personnel familiar with the construction and operation of this equipment and the hazards involved should install, adjust, operate, and/or service this equipment. Failure to observe precaution could result in severe bodily injury or loss of life.

- Allow sufficient clearance in the area of the motor for it to stay within its specified operating temperature as well as protected from direct splash or spray of cutting fluids or lubricating oils. Refer to *Before Mounting Your Motor* for additional information.
- Refer to *Using Belted Drives and Coupled Drives* to determine proper installation in regard to using belted and coupled drives.
- Mount your motor on a rigid, solid base, or foundation. Poor base construction may cause resonances in the motor/base assembly, which can result in bearing failure and other motor damage. Use the correct grade of hold down bolts for the type of mounting. Refer to *Specifications* for recommended bolt torque values.
- Determine that you have properly constructed cables available for your application. Refer to the *8720MC High Performance Drive Installation Manual* (publication 8720MC-IN001x-EN-P) for information regarding cable construction.

Wiring Your 8720SM Motor Power

The procedures in this section assume you have installed your 8720SM motor correctly. This section includes:

- determining conduit box orientation
- wiring your motor power
- determining your feedback connections
- verifying thermal protector (thermostat leads) connections

Determining Conduit Box Orientation

The standard conduit box location for totally enclosed motors is top mounted for left or right conduit entry without motor disassembly. The 8720SM motors allow rotation of the conduit box in 90 degree increments for lead outlet at front, back, or sides.

Wiring Your Motor Power

To wire your 8720SM three-phase motor power:

1. Bring 4 wire shielded Beldon VFD cable or equal to these connections. For applications above 130A, use thick insulation lead wire such as RHW-2 or equal and thread the wires through a single grounded metal conduit.

8720SM Motor:	8720MC Drive (TB1 terminal):
U (T1)	U
V (T2)	V
W (T3)	W
⊥	⊥
Shield	⊥ Clamp

Figure 1
8720SM-005S1BASx Thru -093S6TASx Motors

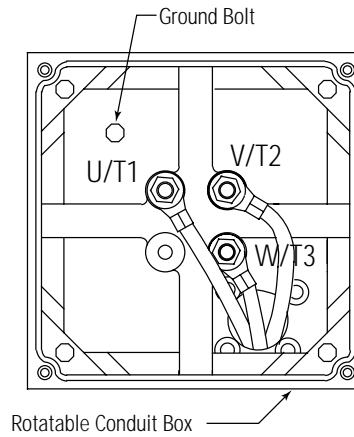

2. Connect the shield to both the motor ground and the PE ground on the drive with an 6 mm² (AWG 10) or larger conductor. Refer to the *8720MC High Performance Drive Installation Manual* (publication 8720MC-IN001x-EN-P) for the PE ground terminal on the 8720MC drive.

ATTENTION



Connect an appropriate equipment grounding conductor to the 8720MC drive ground terminal, the motor frame, the transformer enclosure if used, the drive electrical enclosure, and an appropriate grounding electrode. Failure to observe these precautions could result in severe bodily injury or loss of life.

Determining Your Feedback Connections

Refer to the following table to determine the motor/integrated feedback device combination.

Motor	Encoder Type	Control Type
8720SM-xxxxxxxS3 and -xxxxxxxS4	Incremental sine/cosine	Analog
8720SM-xxxxxxxS1	Single-turn absolute feedback	SERCOS
8720SM-xxxxxxxS2	Multi-turn absolute feedback	

These feedback devices provide precision servo performance for both spindle and power servo applications. The motor feedback cable (2090-CDNFDMP-Sxx) shown in Figure 2 applies to the 8720SM-xxxxxxxS1, S2, and S4 motor configurations.

Figure 2
Motor Feedback Cable (8720SM-xxxxxxxS1, S2, and S4)

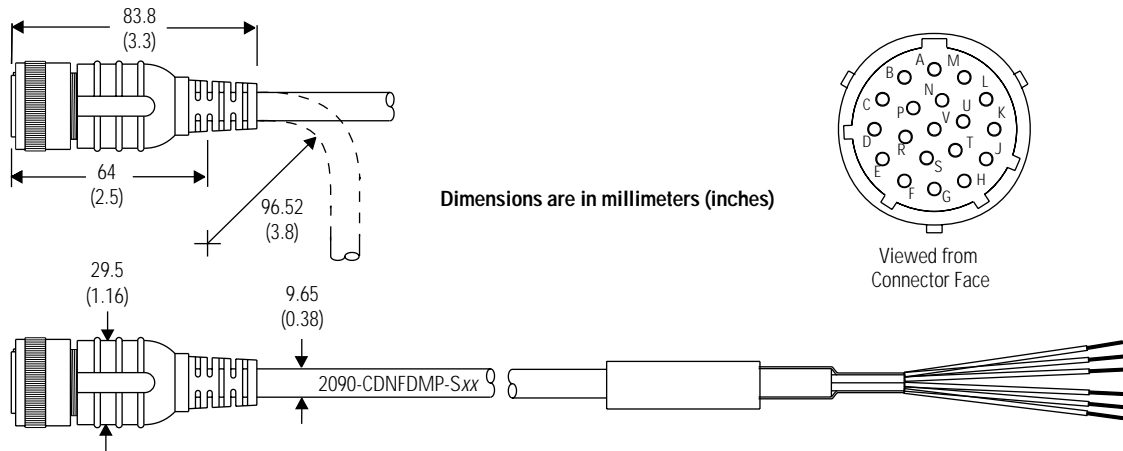

The mating right-angle P-Lok feedback connector shown in Figure 3 applies to the 8720SM-xxxxxxxS3 motor (and ships with each motor). This connector is designed for solder joints at each termination. The Amphenol catalog number is P3106Z2029S23. Catalog number ST-385-16S-08D pins are also provided.

Figure 3
Motor Feedback Connector (8720SM-xxxxxxxS3)

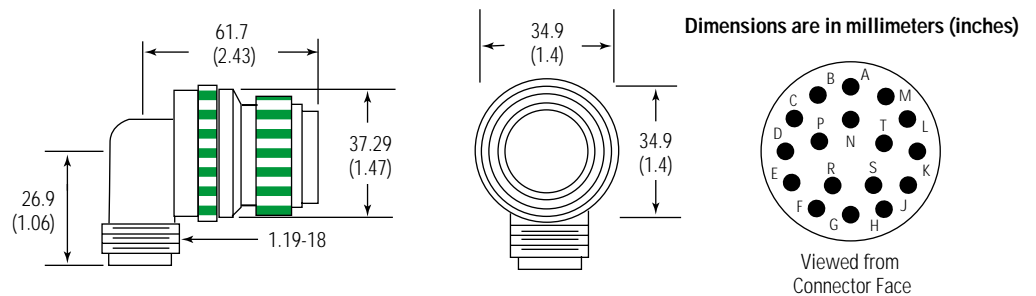

Verifying Thermal Protector (Thermostat Leads) Connections

The 8720SM motors have three normally closed thermostats. There is one thermostat per phase, connected in series, with leads terminated to the feedback connector on the motor via the feedback cable. To protect against motor overheating, make sure that you connect the thermostats to the appropriate drive connector. Refer to the table below for the motor and drive pins. Prior to initial startup assure that there is very high resistance between each of the motor leads and the thermal switch leads, as well as very high resistance from ground to the thermal switch leads. The thermal protector is rated for 170° C (338° F).

IMPORTANT

Failure to connect the thermostats will void the motor warranty.

8720SM-xxxxxxxS1, -S2, and -S4 Motor Feedback Connector Pin	8720SM-xxxxxxxS3 Motor Feedback Connector Pin	8720MC Connector Pin	Signal
R	K	P1-12	TS+
S	L	P1-13	TS-

Refer to the *8720MC High Performance Drive Installation Manual* (publication 8720MC-IN001x-EN-P) for wiring and connector information.

Blower Motor

8720SM motors are blower cooled; incorporating an independently powered three-phase AC blower motor that ensures continuous air flow, regardless of the AC motor speed.

ATTENTION



The blower motor is typically wired to the AC input of the 8720MC drive and is energized even when the drive is not running. Before touching blower motor components, make sure to turn off and lock out or tag the main power supply. Failure to observe this precaution could result in severe bodily injury or loss of life.

The table below lists the necessary air flow cubic feet per minute (CFM) requirements for the motors. The cooling inlet air must not exceed 40° C (104° F). Allow a 101.6 mm (4 in.) gap, minimum, at the back of the motor to assure proper air flow.

Motor	Blower Motor	CFM @ 60 Hz	Static Pressure (inches of water)
8720SM-005S1BAS _x , -005S1BBS _x , -005S1BCS _x , -007S1CAS _x , -007S1CBS _x , -007S1CCS _x , -011S1DAS _x , -011S1DBS _x , and -011S1DCS _x	613450-1G	547	1.5
8720SM-015S2EAS _x , -015S2EBS _x , -015S2ECS _x , -018S2FAS _x , -018S2FBS _x , and -022S2GAS _x		547	1.5
8720SM-030S4JAS _x and -037S4KAS _x	613450-2E	1117	1.75
8720SM-045S5NAS _x , -055S5PAS _x , and -063S5QAS _x		1117	2.00
8720SM-075S6SAS _x and -093S6TAS _x		1117	2.25

If the blower motor direction of rotation is not correct the airflow will be opposite to the arrow on the motor and it will be far lower in air flow than what is required to cool the motor. In the standard configuration, all 8720SM motors blow air from the blower end to the drive end.

Connecting the Blower Motor

The specific 8720SM AC blower motor will vary depending on frame size and enclosure. The smallest motors, 8720SM-005S1BAS x thru -022S2GAS x , have a 547 CFM blower while the 8720SM-030S4JAS x thru -093S6TAS x motors have a 1117 CFM blower. In addition:

- The blower motors should have a fuse in each phase. The 8720SM blower motor should use a 1 amp, time delay current limiting fuse. A Bussmann® fuse (LP-CC-1) is recommended.
- Use #16 to #18 AWG 600V hook-up wire, Alpha 3075 or 3077 or equal.

Refer to the connection diagram supplied with each blower motor for connection information. Figure 4 provides an example of the high, or star, voltage 460V ac connection.

Figure 4
Blower Motor Connections

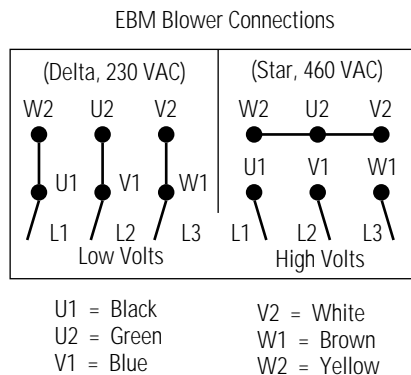

To connect the blower motor:

1. Connect for the appropriate voltage based on the type of blower installed.

IMPORTANT

The motor warranty conditions are violated if you connect the blower for low voltage and apply more than 240V ac.

2. Check that the direction of air flow is in agreement with the direction of air flow arrows mounted on the motor. If directional air flow is incorrect, interchange power leads L1 and L2, or U1, and V1.

Motor Operation and Maintenance

The standard 8720SM motors are equipped with sealed deep groove ball bearings. The motors are packed with the appropriate lubricant at the factory and do not require maintenance.

ATTENTION

Internal parts of the motor may be at line potential even when the motor is not rotating. Make sure to disconnect all power from the motor before contacting an internal part. Failure to observe this precaution could result in bodily injury or loss of life.

ATTENTION

The surface of the motor may reach high temperatures. Avoid contact with motor surfaces and wear suitable protective equipment.

Repairing Your Motor

8720SM motors are high performance products and are only authorized for repair at Rockwell Automation approved repair facilities. Contact your local Rockwell Automation representative for information regarding approved facilities and return procedures.

ATTENTION

8720SM motors are equipped with a smart feedback device which contains detailed information specific to that motor. You cannot replace the feedback device supplied with the motor. Feedback devices purchased from the supplier of the device will not function, resulting in possible equipment damage or personal injury.

Specifications

Environmental and Weight Specifications

Specification	Description
Rated ambient temperature	0° to 40° C (32° to 104° F)
Storage temperature	-20° to 80° C (-4° to 176° F)
Environmental protection	IP 55
Agency certification	UL/CSA/CE
Available mounting methods	flange/foot
Weight	
8720SM-005S1BxSx	75 kg (165 lb)
8720SM-007S1CxSx	91 kg (201 lb)
8720SM-011S1DxSx	102 kg (225 lb)
8720SM-015S2ExSx	131 kg (289 lb)
8720SM-018S2FASx	150 kg (331 lb)
8720SM-022S2GASx	163 kg (359 lb)
8720SM-030S4JASx	226 kg (497 lb)
8720SM-037S4KASx	272 kg (598 lb)
8720SM-045S5NASx	297 kg (655 lb)
8720SM-055S5PASx	324 kg (714 lb)
8720SM-063S5QASx	350 kg (772 lb)
8720SM-075S6SASx	453 kg (999 lb)
8720SM-093S6TASx	478 kg (1054 lb)

IMPORTANT

The IP55 rating is based on contact with water spray. The motor must *not* be exposed to direct splash or spray of cutting fluids or lubricating oils.

Performance Specifications

The motors are available with power ratings from 5.5 to 93 kW (7.5 to 125 hp) and are designed to operate with the 8720MC 380V ac to 480V ac input inverters, as well as the 8720MC regenerative power supply. The following table provides general rating information for the 8720SM motors.

Motor 8720SM-	Maximum Speed rpm	Rated Current (RMS) at 1500 rpm Base Speed Amps	Continuous Stall Torque N-m (lb-ft)	Peak Stall Torque N-m (lb-ft)	Motor Rated Output kW (hp)	Base Speed rpm	Rotor Inertia kg-m ² (lb-ft ²)
005S1BASx	9000	13.5	32 (25.8)	53 (39.1)	5.5 (7.37)	1500	0.0165 (0.391)
005S1BBSx	9000	19.3	32 (25.8)	53 (39.1)	5.5 (7.37)	1500	0.0165 (0.391)
005S1BCSx	9000	20.2	32 (25.8)	53 (39.1)	5.5 (7.37)	1500	0.0165 (0.391)
007S1CASx	9000	20.3	48 (35.4)	72 (53.1)	7.5 (10)	1500	0.0222 (0.527)
007S1CBSx	9000	26.4	48 (35.4)	72 (53.1)	7.5 (10)	1500	0.0222 (0.527)
007S1CCSx	9000	26.4	48 (35.4)	72 (53.1)	7.5 (10)	1500	0.0222 (0.527)
011S1DASx	9000	26.8	70 (51.6)	105 (77.4)	11 (14.7)	1500	0.0272 (0.645)
011S1DBSx	9000	32.3	70 (51.6)	105 (77.4)	11 (14.7)	1500	0.0272 (0.645)
011S1DCSx	9000	32.3	70 (51.6)	105 (77.4)	11 (14.7)	1500	0.0272 (0.645)
015S2EASx	8000	33.4	96 (70.8)	143 (105.5)	15 (20.1)	1500	0.08.0 (1.92)
015S2EBSx	8000	41.5	96 (70.8)	143 (105.5)	15 (20.1)	1500	0.08.0 (1.92)
015S2ECSx	8000	48	96 (70.8)	142 (104.7)	15 (20.1)	1500	0.08.0 (1.92)
018S2FASx	8000	41.4	118 (87)	176 (129.8)	18.5 (24.8)	1500	0.0977 (2.32)
018S2FBSx	8000	47.1	118 (87)	176 (129.8)	18.5 (24.8)	1500	0.0977 (2.32)
022S2GASx	7400	48	140 (130.2)	210 (154.9)	22 (29.5)	1500	0.111 (2.63)
030S4JASx	6000 (6500) ¹	63.1	192 (141.5)	290 (213.4)	30 (40)	1500	0.176 (4.2)
037S4KASx	5800 (6500) ¹	76.1	238 (175.40)	355 (261.8)	37 (50)	1500	0.20 (4.9)
045S5NASx	6000 (6500) ¹	93	287 (211.5)	430 (317.2)	45 (60)	1500	0.35 (8.3)
055S5PASx	5000	116	350 (258)	525 (387.2)	55 (73.7)	1500	0.409 (9.7)
063S5QASx	5000	117.5	400 (294.8)	600 (442)	63 (84.4)	1500	0.468 (11.1)
075S6SASx	4500 (5000) ¹	137	480 (353.8)	720 (531.1)	75 (100.5)	1500	0.885 (21)
093S6TASx	4000 (4500) ¹	176	590 (434.8)	890 (656.5)	93 (125)	1500	1.01 (24)

¹ The first value listed is for flange mount versions and the second value (in parenthesis) is for foot mount versions.

Mounting Bolt Specifications

Hole Diameter mm (in.)	Bolt Size and Thread	Recommended Torque Nm (lb-ft)
12 (0.47)	M10-1.5	52.9 (39)
14 (0.55)	M12-1.75	90.8 (67)
15 (0.59)	M12-1.75	90.8 (67)
18 (0.70)	M16-2.00	226.4 (167)
19 (0.74)	M16-2.00	226.4 (167)

Refer to the *8720MC High Performance Drive Integration Manual* (publication 8720MC-IN002x-EN-P) for additional motor performance specifications.

Dimensions

Within this section you will find dimension drawings for the 8720SM motors. The following notes apply to all motor dimensional drawings:

Note	Description:
1	"H" Dimension will not be exceeded. Shims up to 0.5 mm (0.019 in.) thickness are usually required for coupled or geared machines .
2	Shaft extensions are according to Din 748. Tolerances are based on the ISO fitting system using K6 for diameters up to 50 mm (1.96 in.) and m6 for diameters above.
3	"GA" varies +.018/-.290 mm.
4	Walls or obstructions must not encroach on air inlet space "XI" for blower or fan cooling.
5	Tolerances for flange according to DIN42948.
6	Terminal box can be rotated in 90 degree increments and mounted on top as standard.

8720SM-005S1, -007S1, and -011S1 Dimensions (Before March 01)

The following motor dimensions are for 8720SM-005S1BAS_x thru -011S1DCS_x motors, 180 mm flange and 215 mm bolt circle manufactured before March, 2001.

Figure 5
8720SM-005S1BAS_x thru -011S1DCS_x Motor Dimensions

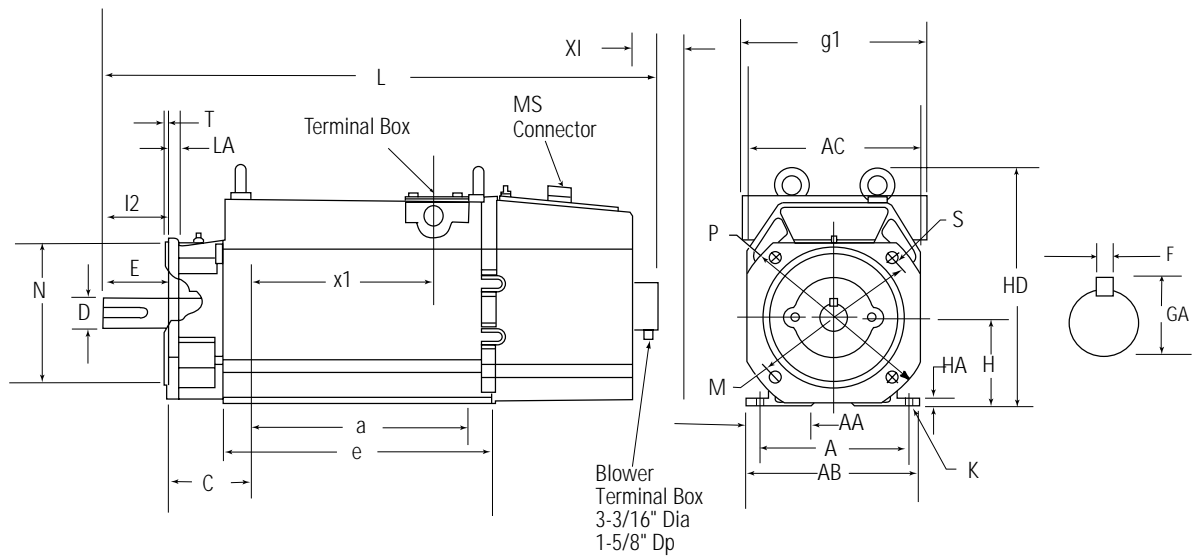

Motor 8720SM-	AB mm (in.)	H ¹ mm (in.)	A mm (in.)	HA mm (in.)	K mm (in.)	AA mm (in.)	AC mm (in.)	C mm (in.)	P mm (in.)	N mm (in.)	LA mm (in.)	M mm (in.)	T mm (in.)
005	233 (9.17)	112 (4.40)	190 (7.48)	9 (0.35)	12 (0.47)	83.5 (3.28)	240 (9.44)	106 (4.17)	250 (9.84)	180 (7.08)	13 (0.51)	215 (8.46)	4 (0.15)
007	233 (9.17)	112 (4.40)	190 (7.48)	9 (0.35)	12 (0.47)	83.5 (3.28)	240 (9.44)	106 (4.17)	250 (9.84)	180 (7.08)	13 (0.51)	215 (8.46)	4 (0.15)
011	233 (9.17)	112 (4.40)	190 (7.48)	9 (0.35)	12 (0.47)	83.5 (3.28)	240 (9.44)	106 (4.17)	250 (9.84)	180 (7.08)	13 (0.51)	215 (8.46)	4 (0.15)

Motor 8720SM-	S mm (in.)	XI ⁴ mm (in.)	L mm (in.)	e mm (in.)	x1 mm (in.)	a mm (in.)	D ² mm (in.)	E mm (in.)	I2 mm (in.)	GA ³ mm (in.)	F mm (in.)	g1 mm (in.)	HD mm (in.)
005	14 (0.55)	38 (1.49)	642 (25.27)	269 (10.59)	134 (5.27)	203 (7.99)	38 (1.49)	80 (3.14)	80 (3.14)	41 (1.61)	10 (0.39)	242 (9.52)	305 (120)
007	14 (0.55)	38 (1.49)	687 (27.04)	313 (12.32)	178 (7.00)	248 (9.36)	38 (1.49)	80 (3.14)	80 (3.14)	41 (1.61)	10 (0.39)	242 (9.52)	305 (120)
011	14 (0.55)	38 (1.49)	725 (28.54)	352 (13.85)	216 (8.50)	286 (11.25)	38 (1.49)	80 (3.14)	80 (3.14)	41 (1.61)	10 (0.39)	242 (9.52)	305 (120)

8720SM-005S1, -007S1, and -011S1 Dimensions (After March 01)

The following motor dimensions are for 8720SM-005S1BAS_x thru -011S1DCS_x motors, 180 mm flange and 215 mm bolt circle manufactured after March, 2001.

Figure 6
8720SM-005S1BAS_x thru -011S1DCS_x Motor Dimensions

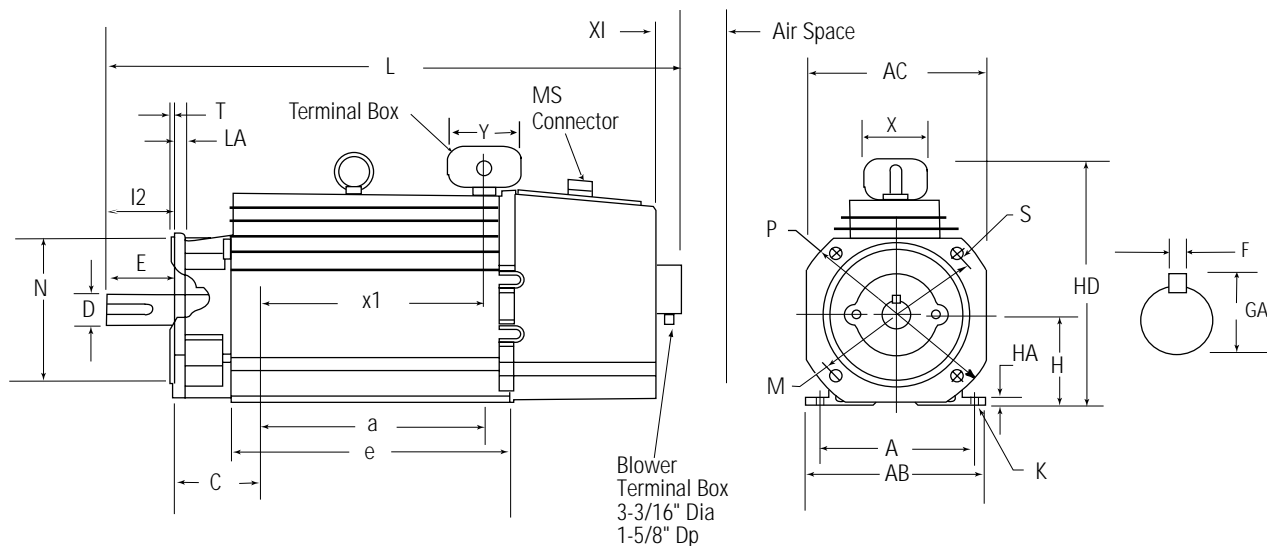

Motor 8720SM-	AB mm (in.)	H ¹ mm (in.)	A mm (in.)	HA mm (in.)	K mm (in.)	AC mm (in.)	C mm (in.)	P mm (in.)	N mm (in.)	LA mm (in.)	M mm (in.)	T mm (in.)	S mm (in.)
005	233 (9.17)	112 (4.40)	190 (7.48)	11 (0.43)	12 (0.47)	240 (9.44)	106 (4.17)	250 (9.84)	180 (7.08)	13 (0.51)	215 (8.46)	4 (0.15)	14 (0.55)
007	233 (9.17)	112 (4.40)	190 (7.48)	11 (0.43)	12 (0.47)	240 (9.44)	106 (4.17)	250 (9.84)	180 (7.08)	13 (0.51)	215 (8.46)	4 (0.15)	14 (0.55)
011	233 (9.17)	112 (4.40)	190 (7.48)	11 (0.43)	12 (0.47)	240 (9.44)	106 (4.17)	250 (9.84)	180 (7.08)	13 (0.51)	215 (8.46)	4 (0.15)	14 (0.55)

Motor 8720SM-	XI ⁴ mm (in.)	L mm (in.)	e mm (in.)	x1 mm (in.)	a mm (in.)	D ² mm (in.)	E mm (in.)	I2 mm (in.)	GA ³ mm (in.)	F mm (in.)	HD mm (in.)	Y mm (in.)	X mm (in.)
005	38 (1.49)	642 (25.27)	269 (10.59)	134 (5.27)	203 (7.99)	38 (1.49)	80 (3.14)	80 (3.14)	41 (1.61)	10 (0.39)	351 (13.81)	156 (6.12)	143 (5.62)
007	38 (1.49)	687 (27.04)	313 (12.32)	178 (7.00)	248 (9.36)	38 (1.49)	80 (3.14)	80 (3.14)	41 (1.61)	10 (0.39)	351 (13.81)	156 (6.12)	143 (5.62)
011	38 (1.49)	725 (28.54)	352 (13.85)	216 (8.50)	286 (11.25)	38 (1.49)	80 (3.14)	80 (3.14)	41 (1.61)	10 (0.39)	351 (13.81)	156 (6.12)	143 (5.62)

8720SM-015S2, -018S2, and -022S2 Dimensions (250 mm Flange)

The following motor dimensions are for the 8720SM-015S2EAS_x thru -022S2GAS_x motors, the standard “132” with 250 mm flange and 300 mm bolt circle.

Figure 7
8720SM-015S2EAS_x thru -022S2GAS_x Motor Dimensions, 250 mm Flange,

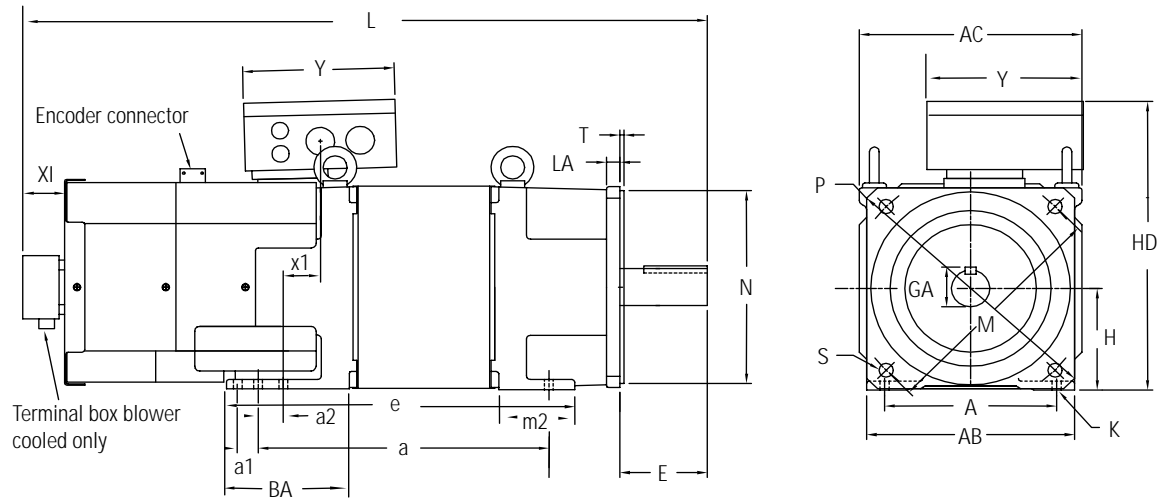

Motor 8720SM-	AB mm (in.)	H ¹ mm (in.)	A mm (in.)	K mm (in.)	AC mm (in.)	BA mm (in.)	m2 mm (in.)	P mm (in.)	N mm (in.)	LA mm (in.)	M mm (in.)	T mm (in.)	S mm (in.)
015	260 (10.23)	132 (5.19)	216 (8.50)	12 (0.47)	279 (10.98)	154 (6.06)	95 (3.74)	350 (13.77)	250 (9.84)	17 (0.66)	300 (11.81)	5 (0.19)	18 (0.70)
018	260 (10.23)	132 (5.19)	216 (8.50)	12 (0.47)	279 (10.98)	154 (6.06)	95 (3.74)	350 (13.77)	250 (9.84)	17 (0.66)	300 (11.81)	5 (0.19)	18 (0.70)
022	260 (10.23)	132 (5.19)	216 (8.50)	12 (0.47)	279 (10.98)	154 (6.06)	95 (3.74)	350 (13.77)	250 (9.84)	17 (0.66)	300 (11.81)	5 (0.19)	18 (0.70)

Motor 8720SM-	XI ⁴ mm (in.)	L mm (in.)	e mm (in.)	x1 mm (in.)	a mm (in.)	a1 mm (in.)	a2 mm (in.)	D ² mm (in.)	E mm (in.)	GA ³ mm (in.)	HD mm (in.)	Y mm (in.)
015	52 (2.04)	858 (33.77)	437 (17.20)	46 (1.81)	365 (14.37)	24 (0.94)	32 (1.25)	48 (1.88)	110 (4.33)	51.5 (2.02)	374 (14.72)	190 (7.48)
018	52 (2.04)	897 (35.31)	475 (18.70)	46 (1.81)	403 (15.86)	24 (0.94)	32 (1.25)	48 (1.88)	110 (4.33)	51.5 (2.02)	374 (14.72)	190 (7.48)
022	52 (2.04)	928 (36.53)	506 (19.92)	46 (1.81)	435 (17.12)	24 (0.94)	32 (1.25)	48 (1.88)	110 (4.33)	51.5 (2.02)	374 (14.72)	190 (7.48)

8720SM-030S4 and -037S4 Dimensions

The following motor dimensions are for the 8720SM-030S4JASx thru -037S4KASx motors, 300 mm flange and 350 mm bolt circle.

Figure 8
8720SM-030S4JASx thru -037S4KASx Motor Dimensions

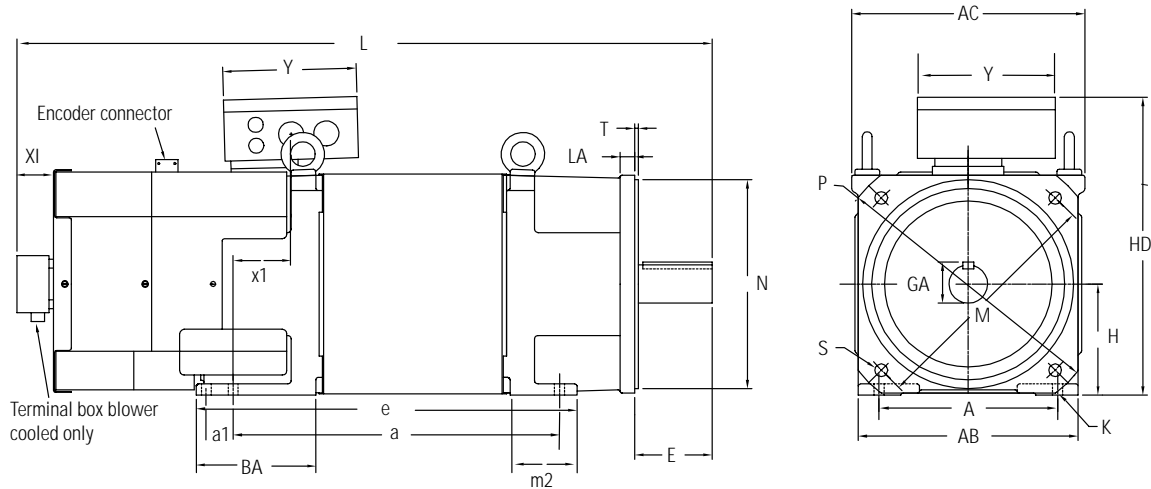

Motor 8720SM-	AB mm (in.)	H ¹ mm (in.)	A mm (in.)	K mm (in.)	AC mm (in.)	BA mm (in.)	m2 mm (in.)	P mm (in.)	N mm (in.)	LA mm (in.)	M mm (in.)	T mm (in.)
030	313 (12.32)	160 (6.29)	254 (9.99)	14 (0.55)	332 (13.07)	170 (6.69)	95 (3.74)	400 (15.78)	300 (11.81)	21 (0.82)	350 (13.77)	5 (0.19)
037	313 (12.32)	160 (6.29)	254 (9.99)	14 (0.55)	332 (13.07)	170 (6.69)	95 (3.74)	400 (15.78)	300 (11.81)	21 (0.82)	350 (13.77)	5 (0.19)

Motor 8720SM-	S mm (in.)	XI ⁴ mm (in.)	L mm (in.)	e mm (in.)	x1 mm (in.)	a mm (in.)	a1 mm (in.)	D ² mm (in.)	E mm (in.)	GA ³ mm (in.)	Y mm (in.)
030	18 (0.70)	52 (2.04)	989 (38.93)	541 (21.29)	82 (3.22)	464 (18.26)	38 (1.49)	55 (2.16)	110 (4.33)	59 (2.32)	190 (7.48)
037	18 (0.70)	52 (2.04)	1040 (40.94)	592 (23.30)	82 (3.22)	515 (20.27)	38 (1.49)	55 (2.16)	110 (4.33)	59 (2.32)	190 (7.48)

8720SM-045S5, -055S5, and -063S5 Dimensions

The following motor dimensions are for the 8720SM-045S5NAS_x thru -063S5QAS_x motors, 300 mm flange and 350 mm bolt circle.

Figure 9
8720SM-045S5NAS_x thru -063S5QAS_x Motor Dimensions

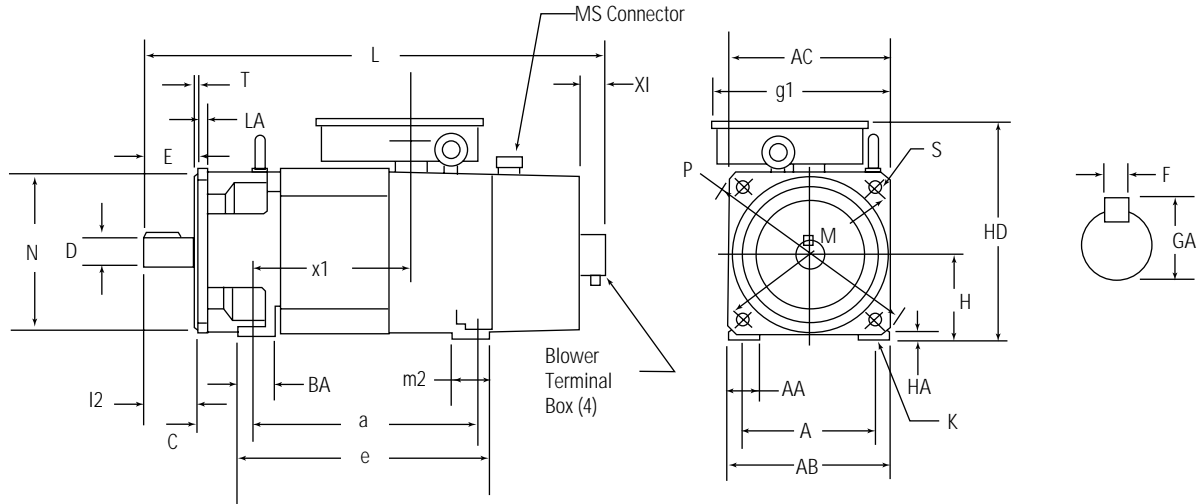

Motor 8720SM-	AB mm (in.)	H mm (in.)	A mm (in.)	HA mm (in.)	K mm (in.)	AA mm (in.)	AC mm (in.)	C mm (in.)	BA mm (in.)	m2 mm (in.)	P mm (in.)	N mm (in.)	LA mm (in.)	M mm (in.)
045	350 (13.77)	180 (7.08)	279 (10.98)	15 (0.59)	15 (0.59)	70 (2.75)	355 (13.97)	121 (4.76)	65 (2.55)	175 (6.88)	400 (15.78)	300 (11.81)	21 (0.82)	350 (13.77)
055	350 (13.77)	180 (7.08)	279 (10.98)	15 (0.59)	15 (0.59)	70 (2.75)	355 (13.97)	121 (4.76)	65 (2.55)	175 (6.88)	400 (15.78)	300 (11.81)	21 (0.82)	350 (13.77)
063	350 (13.77)	180 (7.08)	279 (10.98)	15 (0.59)	15 (0.59)	70 (2.75)	355 (13.97)	121 (4.76)	65 (2.55)	175 (6.88)	400 (15.78)	300 (11.81)	21 (0.82)	350 (13.77)

Motor 8720SM-	T mm (in.)	S mm (in.)	XI mm (in.)	L mm (in.)	e mm (in.)	x1 mm (in.)	a mm (in.)	D mm (in.)	E mm (in.)	I2 mm (in.)	GA mm (in.)	F mm (in.)	g1 mm (in.)	HD mm (in.)
045	5 (0.19)	18 (0.70)	43 (1.69)	997 (39.25)	571 (22.48)	421 (16.57)	520 (20.47)	60 (2.36)	140 (5.51)	140 (5.51)	64 (2.51)	18 (0.70)	319 (12.55)	491 (19.33)
055	5 (0.19)	18 (0.70)	43 (1.69)	1048 (41.25)	622 (24.48)	472 (18.58)	571 (22.48)	60 (2.36)	140 (5.51)	140 (5.51)	64 (2.51)	18 (0.70)	319 (12.55)	491 (19.33)
063	5 (0.19)	18 (0.70)	43 (1.69)	1099 (43.26)	673 (26.49)	523 (20.59)	622 (24.48)	60 (2.36)	140 (5.51)	140 (5.51)	64 (2.51)	18 (0.70)	319 (12.55)	491 (19.33)

8720SM-075S6 and -093S6 Dimensions

The following motor dimensions are for the 8720SM-075S6SASx thru -093S6TASx motors.

Figure 10
8720SM-075S6SASx thru -093S6TASx Motor Dimensions

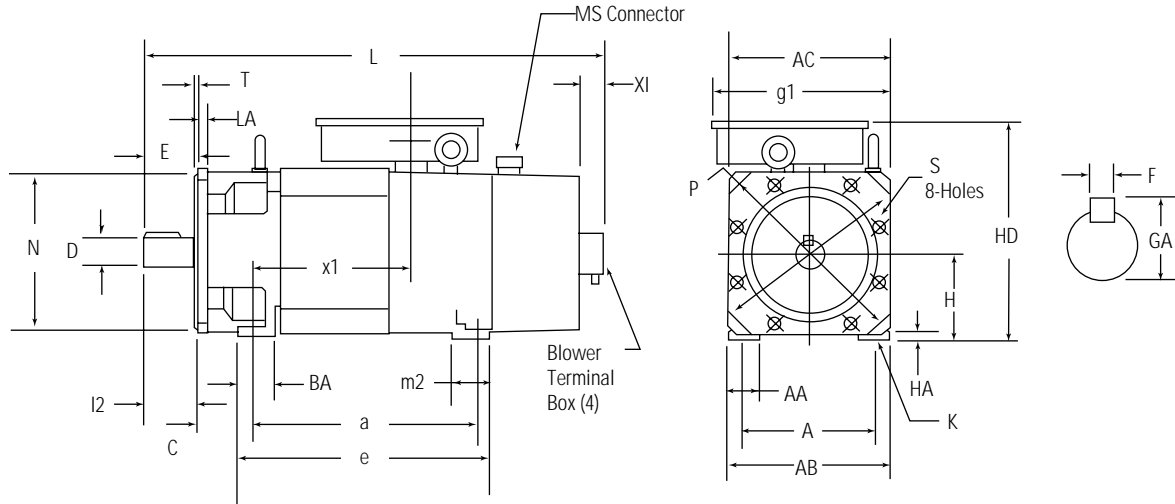

Motor	AB	H	A	HA	K	AA	AC	C	BA	m2	P	N	LA	M
8720SM-	mm (in.)	mm (in.)	mm (in.)	mm (in.)	mm (in.)	mm (in.)	mm (in.)	mm (in.)	mm (in.)	mm (in.)	mm (in.)	mm (in.)	mm (in.)	mm (in.)
075	396 (15.59)	200 (7.84)	318 (12.51)	18 (0.70)	19 (0.74)	80 (3.14)	418 (16.45)	133 (5.23)	82 (3.22)	203 (7.99)	450 (17.71)	350 (13.77)	22 (0.86)	400 (15.74)
093	396 (15.59)	200 (7.84)	318 (12.51)	18 (0.70)	19 (0.74)	80 (3.14)	418 (16.45)	133 (5.23)	82 (3.22)	203 (7.99)	450 (17.71)	350 (13.77)	22 (0.86)	400 (15.74)

Motor	T	S	XI	L	e	x1	a	D	E	12	GA	F	g1	HD
8720SM-	mm (in.)	mm (in.)	mm (in.)	mm (in.)	mm (in.)	mm (in.)	mm (in.)	mm (in.)	mm (in.)	mm (in.)	mm (in.)	mm (in.)	mm (in.)	mm (in.)
075	5 (0.19)	18 (0.70)	43 (1.69)	1155 (45.47)	705 (27.75)	499 (19.64)	654 (25.74)	65 (2.55)	140 (5.51)	140 (5.51)	69 (2.71)	18 (0.70)	351 (13.81)	534 (21.02)
093	5 (0.19)	18 (0.70)	43 (1.69)	1219 (47.99)	769 (30.27)	563 (22.16)	718 (28.26)	65 (2.55)	140 (5.51)	140 (5.51)	69 (2.71)	18 (0.70)	351 (13.81)	534 (21.02)

Motor Load Force Ratings

Motors are capable of operating with a sustained shaft load. The radial and axial load force locations are shown in Figure 11, and the maximum figures are in the tables.

Figure 11
Load Forces on Motor Shaft

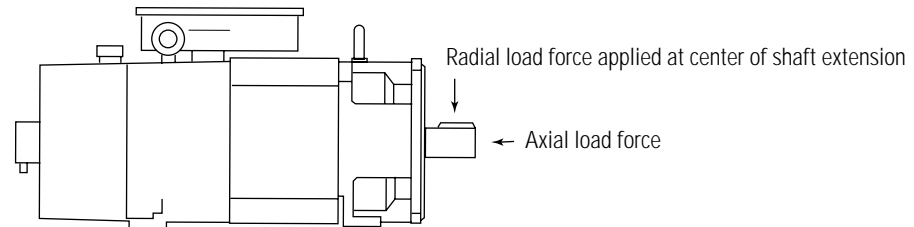

The tables represent 10,000 hour L10 bearing fatigue life at various loads and speeds. The 10,000 hour life does not account for possible application specific life reduction that may occur due to bearing grease contamination from external sources.

Radial Load Force Ratings (Zero Axial Load)

Motor Series 8720SM-	500 RPM kg (lb)	1000 RPM kg (lb)	1500 RPM kg (lb)	2000 RPM kg (lb)	3000 RPM kg (lb)
005	284 (625)	261 (575)	223 (490)	205 (450)	177 (390)
007	284 (625)	261 (575)	223 (490)	205 (450)	177 (390)
011	284 (625)	261 (575)	223 (490)	205 (450)	177 (390)
015	386 (850)	302 (665)	261 (575)	237 (520)	205 (450)
018	386 (850)	302 (665)	261 (575)	237 (520)	205 (450)
022	386 (850)	302 (665)	261 (575)	237 (520)	205 (450)
030	606 (1335)	477 (1050)	411 (905)	370 (815)	320 (705)
037	606 (1335)	477 (1050)	411 (905)	370 (815)	320 (705)
045	640 (1410)	497 (1095)	429 (945)	350 (770)	230 (505)
055	640 (1410)	497 (1095)	429 (945)	350 (770)	230 (505)
063	640 (1410)	497 (1095)	429 (945)	350 (770)	230 (505)
075	699 (1540)	540 (1190)	443 (975)	338 (745)	205 (450)
093	699 (1540)	540 (1190)	443 (975)	338 (745)	205 (450)

Axial Load Force Ratings (Zero Radial Load)

Motor Series 8720SM-	500 RPM kg (lb)	1000 RPM kg (lb)	1500 RPM kg (lb)	2000 RPM kg (lb)	3000 RPM kg (lb)
005	307 (675)	228 (500)	187 (410)	161 (355)	100 (220)
007	307 (675)	228 (500)	187 (410)	161 (355)	100 (220)
011	307 (675)	228 (500)	187 (410)	161 (355)	100 (220)
015	284 (625)	200 (440)	160 (350)	135 (295)	75 (165)
018	284 (625)	200 (440)	160 (350)	135 (295)	75 (165)
022	284 (625)	200 (440)	160 (350)	135 (295)	75 (165)
030	338 (745)	239 (525)	189 (415)	157 (345)	86 (190)
037	338 (745)	239 (525)	189 (415)	157 (345)	86 (190)
045	354 (780)	230 (505)	171 (375)	87 (190)	45 (100)
055	354 (780)	230 (505)	171 (375)	87 (190)	45 (100)
063	354 (780)	230 (505)	171 (375)	87 (190)	45 (100)
075	472 (1040)	309 (680)	228 (500)	118 (260)	64 (140)
093	472 (1040)	309 (680)	228 (500)	118 (260)	64 (140)

For more information refer to our web site: www.ab.com/motion
For Allen-Bradley Technical Support information refer to: www.ab.com/support or Tel: (1) 440.646.5800

Allen-Bradley and A-B are registered trademarks of Rockwell Automation.
Bussmann is a registered trademark of Cooper Industries, Inc.

www.rockwellautomation.com

Power, Control and Information Solutions Headquarters

Americas: Rockwell Automation, 1201 South Second Street, Milwaukee, WI 53204-2496 USA, Tel: (1) 414.382.2000, Fax: (1) 414.382.4444
Europe/Middle East/Africa: Rockwell Automation, Vorstlaan/Boulevard du Souverain 36, 1170 Brussels, Belgium, Tel: (32) 2 663 0600, Fax: (32) 2 663 0640
Asia Pacific: Rockwell Automation, Level 14, Core F, Cyberport 3, 100 Cyberport Road, Hong Kong, Tel: (852) 2887 4788, Fax: (852) 2508 1846

Publication 8720SM-IN001A-EN-P — February 2003

Copyright © 2003 Rockwell Automation. All rights reserved. Printed in USA.