

Installation Instructions

Original Instructions



GuardShield Type 4 and GuardShield Remote Teach

Catalog Numbers 440L-P4x, 440L-C4x, 440L-S4x

Topic	Page
Summary of Changes	1
Description	1
Introduction	1
Safety Precaution	2
Product Description	3
Determine the Safety Distance	7
Installation and Mounting	9
Configuration of Operating Modes in Cascading Systems	11
Electrical Installation	12
Typical Wiring	15
System Configuration	16
Safety Instructions and Maintenance	18
Troubleshooting Guide	19
Catalog Number Explanation	20
Approximate Dimensions	21
Remote Teach	23
System Delivery	24
Corner Mirror for Multi-sided Guarding	26
Weld Shields	29
Optional Accessories	30
Technical Specifications	31
Disposal	35
Certification	35
Declaration of Conformity	35

Summary of Changes

This publication contains the following new or updated information. This list includes substantive updates only and is not intended to reflect all changes.

Topic	Page
Updated Declaration of Conformity	35

Description

This installation instruction covers the operation and installation of the:

- Standard and cascading GuardShield™ safety light curtain
- Remote Teach GuardShield safety light curtain
- GuardShield safety light curtain with integrated laser alignment
- GuardShield safety light curtain with integrated laser alignment and ArmorBlock® Guard I/O™ module

IMPORTANT Save these instructions for future use.

Recognized technical regulations and quality assurance system ISO 9000 are carefully applied during the development and production of Allen-Bradley®/Guardmaster® products.

You must follow this technical description when you install and commission the GuardShield safety light curtain. Only a qualified person can inspect and commission the unit.

We reserve the right to make changes or revisions to the material contained in this publication. Rockwell Automation cannot be held liable for incidental or consequential damages, which result from the furnishing, performance, or use of this material.

Introduction

The GuardShield family of safety light curtains consists of general-purpose presence sensing devices, which are designed for use on hazardous machinery providing point of operation, and perimeter and access detection.

The unit is a self-contained, two-box, Type 4 electro-sensitive protective equipment (ESPE) with DIP switch selectable operating modes.

We offer the GuardShield safety light curtain in a number of configurations that are based on a standard Type 4 safety light curtain platform.

Table 1 - Features

Feature	Description
Integrated laser alignment	An integrated visible laser to support the alignment
Cascade	Cascade allows the serial connection of several GuardShield safety light curtain segments to one long system
Remote teach	Provides a remote teach-in box to configure teach-in blanking
ArmorBlock Guard I/O module connectivity	For network connectivity

Some of the features are available in combinations. For a complete offering, see [Table 36 on page 32](#)...[Table 41 on page 34](#) and [Table 29 on page 25](#).

According to ANSI Z590.3, Z690.3, ISO 14121, and ISO 12100, the GuardShield safety light curtain Type 4 can be used in safety applications in which a risk analysis reaches:

- PLe in a safety Category 4 (EN ISO13849-1)
- SIL 3 (EN 62061)

Features of the GuardShield safety light curtain that are integrated into the system receiver:

- Fixed blanking
- Floating blanking
- External device monitoring (EDM)
- Internal or external restart
- Beam coding
- Laser alignment (option)

IMPORTANT These installation instructions are designed to address the technical personnel of the machine manufacturer and or the installer of the safety system regarding:

- Proper mounting
 - Configuration
 - Electrical installation
 - Commissioning
 - Operation
 - Maintenance of the GuardShield safety light curtain
- These installation instructions do not provide instruction for the operation of machinery to which the GuardShield safety light curtain is integrated. Only qualified personnel can install this equipment.

Safety Precaution

Principles for Safe Use and Symbols Used

The following instructions are preventive warnings to achieve the safe and proper operation of the GuardShield safety light curtain. These instructions are an essential part of the safety precautions and therefore must be observed at any time.

Throughout this manual, we use the labels ATTENTION and IMPORTANT to alert you to the following:



ATTENTION: Failure to observe can result in dangerous operation.

ATTENTION: Identifies information about practices of circumstances that can lead to personal injury or death, property damage, or economic loss.

ATTENTION helps you:

- Identify a hazard
- Avoid a hazard
- Recognize the consequences

IMPORTANT: Identifies information that is especially important for successful application and to understand the product.



ATTENTION: A potentially hazardous situation exists, which, if not stopped, can lead to serious or deadly injury. Failure to observe can result in dangerous operation.



ATTENTION: Do not use the GuardShield safety light curtain with machines that cannot stop electrically in an emergency. Always maintain the safety distance between the GuardShield safety light curtain and a dangerous machine movement. Install additional mechanical protective devices in a way that you cannot reach hazardous machine elements without first passing through the protective field.

Install the GuardShield safety light curtain in a way that operators can only operate within the sensing area. Improper installation can result in serious injury.

Never connect the outputs to +24V DC. If the outputs connect to +24V DC, they are in on-state and cannot stop hazardous spots at the machine/application.

Never expose the GuardShield safety light curtain to flammable or explosive gases.

Regular safety inspections are imperative (see [Safety Instructions and Maintenance on page 18](#)).

Do not repair or modify the GuardShield safety light curtain. The GuardShield safety light curtain is not field repairable and can only be repaired at the factory. Removal of either of the GuardShield safety light curtain endcaps voids the warranty terms of this product.

Specialist Personnel

Only a qualified person can install the GuardShield safety light curtain. A qualified person is defined as a person who:

- Has undergone the appropriate technical training
- The responsible machine operator has instructed in the operation of the machine and the currently valid safety guidelines
- Who has read and has ongoing access to these installation instructions

Range of Uses of the Device

The GuardShield safety light curtain is classified as ESPE. The physical resolution is 14 mm (0.55 in.) or 30 mm (1.18 in.). The maximum protective field width is 7 m (22.9 ft) for the 14 mm (0.55 in.) resolution and 16 m (52 ft) for the 30 mm (1.18 in.) resolution GuardShield safety light curtain. The protective field height is 160...1760 mm (6.3...69.2 in.) in increments of 160 mm.

We offer the GuardShield safety light curtain with an integrated laser alignment system in protective heights of 320...1600 mm (12.6...63 in.). All GuardShield safety light curtains with ArmorBlock Guard I/O module have integrated laser alignment.

The device is a Type 4 ESPE as defined by IEC 61496-1 and IEC 61496-2. Therefore it is allowed for use with controls:

- In safety Cat 4 up to PLe in accordance with EN ISO 13849-1
- SIL CL 3 in accordance with EN 62061

The device is suitable for:

- Point of operation protection (finger and hand protection)
- Hazardous area protection
- Access protection

You must allow access to the hazardous point only through the protective field. The machine/system is not allowed to start as long as personnel are within the hazardous area. See [Examples of Range of Use on page 3](#) for an illustration of the protective modes.

The application can require mechanical protection devices and the safety light curtain.

Proper Use

Only use the GuardShield safety light curtain as defined in [Range of Uses of the Device](#). Only qualified personnel can install and initialize the safety light curtain.

If you use the device for any other purposes or modify it in any way, warranty claims against Allen-Bradley/Guardmaster become null and void.

General Protective Notes and Protective Measures



ATTENTION: Observe the following items to help achieve compliance of the proper and safe use of the GuardShield safety light curtain.

- The national/international rules and regulations apply to the installation, use, and periodic technical inspections of the safety light curtain, in particular:
 - Machine Directive 2006/42/EC
 - Low Voltage Directive 2006/95/EC
 - The work safety regulations/safety rules
 - Other relevant health and safety regulations

Manufacturers and users of the machine with which the safety light curtain is used are responsible for obtaining and observing all applicable safety regulations and rules.

- Observe the notices, in particular the test regulations of these installation instructions (for example, on use, mounting, installation, or integration into the existing machine controller).
- Specialist personnel or specially qualified and authorized personnel conduct the tests. Record and document these results to help confirm that you can reconstruct and retrace the tests at any time.
- The installation instructions must be available to the user of the machine where the GuardShield safety light curtain is installed. Specialist personnel must instruct the machine operator in the use of the device and to read the installation instructions.

Examples of Range of Use

The GuardShield safety light curtain operates as a proper protective device only if the following conditions are met:

- The control of the machine is electrical.
- The controlled machine is able to stop anywhere in the stroke or cycle of the machine.
- Mount the transmitter and receiver so access to the hazard is only through the protective field of the safety light curtain.
- Locate the Restart button outside the hazardous area. This location removes the possibility of operation by a person working inside the hazardous area.
- Observe the statutory and local rules and regulations when you install and use the device.

Restart interlock is not available in GuardShield safety light curtains with ArmorBlock Guard I/O module connectivity.

IMPORTANT Additional measures can be necessary to maintain that the ESPE does not fail to danger when other forms of light radiation are present in a particular application. For instance, with cableless control devices on cranes, radiation from weld spatter, or effects from strobe lights use.

Product Description

This section provides information on the special features and properties of the safety light curtain. This section describes the structure and functions of the unit, in particular the different operating modes.

IMPORTANT Read this section before you mount, install, and commission the unit.

Special Features

- Start interlock
- Restart interlock
- Teachable fixed blanking
- One or two beam floating blanking
- External Device Monitoring (EDM)
- Machine test signal
- Beam coding

GuardShield Safety Light Curtain Principle of Operation

The GuardShield safety light curtain consists of a non-matched pair of optic units, for instance, a transmitter and receiver (see [Figure 1](#)) with the same protective height and resolution. The transmitter and receiver operate on +24V DC. The maximum distance between the transmitter and receiver is referred to as the protective field width or range. The protective field height is the distance between the first and last beam in the device.

The transmitter emits sequential pulses of infrared light, which the GuardShield safety light curtain receives and processes. The first beam next to the status indicators synchronizes optically the timing of emission and reception of the infrared light pulses. This beam is referred to as the synchronization beam. Because the GuardShield safety light curtain transmitter and receiver optically synchronize, the transmitter and receiver do not require an electrical connection between them.

The GuardShield safety light curtain receiver has two safety outputs, Output Signal Switching Devices (OSSDs) and one non-safety auxiliary output. All OSSDs are current sourcing +24V DC with a switching capacity of 500 mA when you properly power and align the GuardShield safety light curtain transmitter and receiver. The two safety OSSDs are cross monitored and have short circuit protection. Interruption of the sensing field causes the receiver to switch off the sourced current (0V DC).

When you restore the sensing field in the guard only (automatic reset) configuration, the OSSD safety outputs switch from the off to the active high on-state (+24V DC).

Figure 1 - Components - Standard GuardShield Safety Light Curtain System

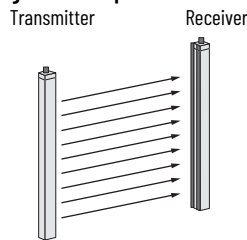
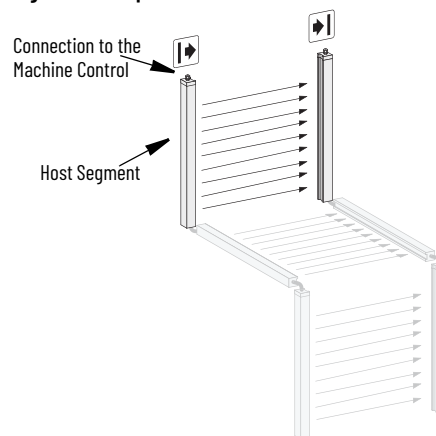

Figure 2 - Components - Cascaded GuardShield Safety Light Curtain System (a)



The black front window indicates the upper and lower limit of the protective field of the standard GuardShield safety light curtain system.

The yellow borders on the laser label and target label indicate the limits of the protective height on the GuardShield safety light curtain with an integrated laser alignment system.

The width of the protective field is the length of the light path between sender and receiver. This width must not exceed the maximum rated width of the protective field, see [Catalog Number Explanation on page 20](#).

(a) This figure indicates three cascade segments.

Cascade Segments

The GuardShield safety light curtain, Type 4 POC is also available in cascade segments which allow a number of GuardShield safety light curtain transmitters and receivers to interconnect in series (see [Figure 2 on page 3](#)). This product configurability allows the GuardShield safety light curtain to protect multiple sides of a machine or adds the flexibility to position the GuardShield safety light curtain in various applications.

We offer standard GuardShield safety light curtain cascade segments in protective heights of 320...1760 mm (12.6...69.29 in.) in both 14 mm (0.55 in.) and 30 mm (1.18 in.) resolutions. We do not offer cascade segments of 160 mm (6.3 in.), however you can use a 160 mm GuardShield safety light curtain as the last segment in a cascading system.

We offer cascading GuardShield safety light curtains with an integrated laser alignment system in protective heights of 320...1600 mm (12.6...63 in.). It is possible to mix standard GuardShield safety light curtains with integrated laser alignment systems.

A maximum of three GuardShield safety light curtains can interconnect with a common pair of OSSDs. There are no limitations for the total number of beams in a cascading system. The maximum number of beams possible is in three 1760 mm (69.29 in.), 14 mm (0.55 in.) resolution GuardShield safety light curtain interconnected segments. The individual segments can have mixed resolutions, for instance, 14 mm (0.55 in.) and 30 mm (1.18 in.), as long as the pairs have the same protective heights and resolutions.

Use cascade segments as standalone safety light curtain pairs or use up to three interconnected segments. These cascading segments all function as independent safety light curtains.

When you use cascade segments as standalone pairs or as the last segment in a cascade system, you must use a termination plug on the top connector of the cascade receiver. You can use a standard GuardShield safety light curtain Type 4 POC pair as the last segment in a cascading system.

Restart interlock is not available in GuardShield safety light curtains with ArmorBlock Guard I/O module connectivity.

GuardShield Safety Light Curtain Laser Alignment

The laser light source in the integrated laser alignment system of the GuardShield safety light curtains is a Class 1, eye-safe laser diode with a wavelength of 670 nm.

This Class 1, eye-safe laser switches from a low-output power state to a high-output power state (and back again) with control circuitry. The unit detects reflected laser light from a temporary blockage of the emitted laser light. The most common way to accomplish this detection is to place a finger over the laser overlay window. There is also an automatic shutdown feature. This feature switches the laser diode from the high-power state to the low-power state if there is no finger or other interruption that is detected for 5 minutes.

During the High Output mode of operation, the laser pulses at a rate of approximately 2 Hz to facilitate finger detection in high ambient light conditions.



ATTENTION: The use of controls, adjustments, or performance of procedures other than specified, can result in hazardous radiation exposure.

Safety Functions

The GuardShield safety light curtain offers various functions that are integral to the system.

Operating modes, functions, and features of the GuardShield safety light curtain system activate through DIP switch settings.

IMPORTANT Test the protective system for proper operation after each change to the configuration.

Guard Only (Automatic Reset)

When in the Guard Only mode of operation, the safety light curtain operates as an on/off device. This operation means that the OSSD outputs switch off/on automatically according to an obstruction or clear view of the detection field. The GuardShield safety light curtain is configured at the factory in Guard Only (automatic reset) mode.

Start Interlock

The start interlock stops the OSSD outputs from switching to the on-state after power-up of the system with the protective field unobstructed. To enter the on-state, the GuardShield safety light curtain requires a manual reset of the system.

You can accomplish the on-state by one of two methods.

- Actuation of a momentary N.O. push button (see [Figure 17 on page 13](#))
- Interruption and restoration of the protective field within 1 second

After the first manual reset after power-up, the safety light curtain continues operating in the Guard Only (automatic reset) mode.

Activation of this mode of operation and selection of the reset method is done via DIP switch settings. The illumination of a yellow status indicator on the GuardShield safety light curtain receiver indicates this mode of operation (see [Figure 26 on page 17](#)).

Start interlock is not available on middle and end segments of a cascading GuardShield safety light curtain system. However, you can configure this operating mode in the host segment and allow the whole cascading system to operate in this mode. Start interlock is not available in GuardShield safety light curtains with ArmorBlock Guard I/O module connectivity.

Restart Interlock (Manual Reset)

The Restart Interlock mode of operation stops the OSSD outputs from switching to on after the interruption and clearance of the protective field. The GuardShield safety light curtain system requires a manual reset. Reset the system through a momentary N.O. push button (see [Figure 17 on page 13](#)) or keyswitch. Configuration and activation of this mode of operation is through DIP switch settings (see [Table 22 on page 16](#)). The illumination of a yellow status indicator on the GuardShield safety light curtain receiver indicates the Restart Interlock mode.

Restart interlock is not available on middle and end segments of a cascading GuardShield safety light curtain system. However, you can configure this operating mode in the host segment, which allows the whole cascading system to operate in this mode (see [Figure 26 on page 17](#)).

Restart interlock is not available in GuardShield safety light curtains with ArmorBlock Guard I/O module connectivity.

Relay Monitoring (MPCE/EDM)

The relay monitor function is an input signal to the GuardShield safety light curtain receiver. This function is used to monitor the state of the protective machinery primary control contactors or other final switching device (see [Figure 16 on page 13](#)). Detection of unsafe conditions such as welded contacts, cause the GuardShield safety light curtain to enter a lockout condition (OSSDs off). Activation of this mode of operation is done via DIP switch setting in the GuardShield safety light curtain receiver (see [Table 20 on page 16](#)).

EDM is not available in the middle and end segments of a cascading GuardShield safety light curtain system. However, it is possible to configure this operating mode in the host segment, which allows the whole cascading system to operate in this mode.

External Device Monitoring (EDM) is not available in GuardShield safety light curtains with ArmorBlock Guard I/O module connectivity.

System Testing

The GuardShield safety light curtain performs a complete system self-test at power-up. The outputs switch to the on-state if the system is in proper alignment and there are no obstructions in the protective field and the Start/Restart Interlock modes of operation are deactivated.

External Test (Machine Test Signal)

An external test signal to the GuardShield safety light curtain transmitter triggers a test cycle of the system. The supply or removal of a signal (+24V DC) via a N.C. or N.O. switch at the test input (see [Figure 22 on page 15](#)) deactivates the transmitter during the test signal. This test signal simulates an interruption of the protective sensing field. Use a DIP switch in the GuardShield safety light curtain transmitter to configure the polarity of the test input (see [Table 21 on page 16](#)). The default setting is that the transmitter works in normal operation if no signal is applied to the test input.

The external test signal is not available in the middle and end segments of a cascading GuardShield safety light curtain system. However, you can configure this feature in the host segment (see [Figure 2 on page 3](#)), which allows the whole cascading system to operate in this mode.

IMPORTANT If a cascading system requires a test cycle, it must have all transmitters in the cascading system configured in the same condition. For instance, all active high or all active low condition.

Beam Coding

If several safety light curtains operate close to one another, the receiver of one GuardShield safety light curtain system can see the infrared light of the transmitter from another system. This situation can cause a nuisance stop. To stop this optical interference, the GuardShield safety light curtain can have the transmitter generate different beam patterns, which is referred to as beam coding. Selection and activation of beam coding is accomplished through DIP switch settings in both the transmitter and receiver.

Non-coded and coded settings are available in the GuardShield safety light curtain.

IMPORTANT Beam coding improves resistance to optical interference. Beam coding increases the system response time, which can also increase the required safety distance. See [Determine the Safety Distance on page 7](#).

Blanking

You can configure the GuardShield safety light curtain with fixed blanking of one or more adjacent beams, exclusive of the synchronization beam. You can also configure floating blanking of one or two beams. You can activate both fixed and floating blanking simultaneously.

Each cascading GuardShield safety light curtain segment pair functions as a standalone safety light curtain with its OSSDs connected in series to the host segment OSSDs. Therefore, you must configure fixed and/or floating blanking in each individual pair segment. To configure, first align all segment pairs and secure the brackets. Then open a segment pair receiver door with the security tool that is provided. Set the appropriate DIP switches and perform the teach function (see [Teach-in Procedure Function on page 17](#)). The successful completion of the teach function changes the operating mode of that segment pair only.

Teach-in Fixed Blanking

The Teach-in Fixed Blanking mode of operation activates through DIP switch settings in the GuardShield safety light curtain receiver (see [Table 20 on page 16](#)). Teach the beams to be blanked by depressing the Teach button that is in the GuardShield safety light curtain receiver end cap, while the object is in the GuardShield safety light curtain sensing field (see [Figure 24 on page 16](#) and [Figure 25 on page 16](#)).

The Fixed Blanking mode of operation is monitored. If you remove a part or the whole taught object from the sensing field, the GuardShield safety light curtain OSSD outputs go to the off-state.

The GuardShield safety light curtain Fixed Blanking mode of operation does not activate until the teach function (see [Teach-in Procedure Function on page 17](#)) is complete and you close the access door.

IMPORTANT Blanked areas can require an additional risk analysis. If no mechanical or other guarding is used to restrict access to the hazard, you must consider the blanked area in the calculation of the safety distance. The configuration and activation of fixed blanking creates a hole in the protective field. If the fixed object in the protective field does not fill the area between the transmitter and receiver, you must obstruct access to the hazard by additional means. You can add hard guards (mechanical barriers) to the open area to accomplish this obstruction.

Figure 3 - Monitored Fixed Blanking of In-feed Rollers

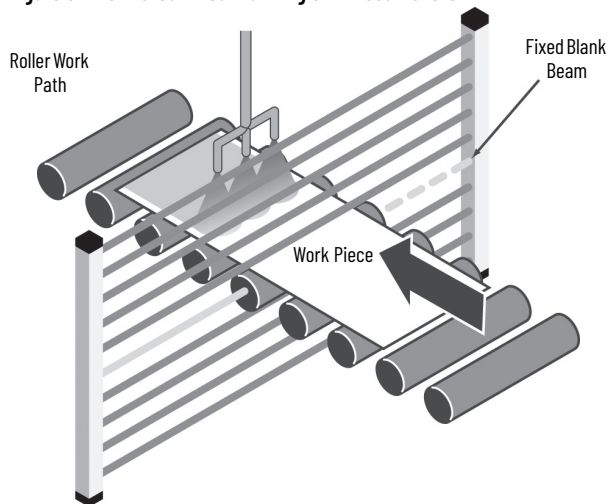

- Beams are taught to ignore the fixed object in the sensing field.
- The fixture or object must remain in the sensing field or the GuardShield safety light curtain enters a fault state.

Fixed blanking enables the blanking out of fixed objects in the sensing area of the safety light curtain. Table 4 on page 6 shows the reaction of the monitored machine with fixed blanking deactivated and activated.

IMPORTANT IEC 62046 provides information on additional means that can be required to stop an operator from reaching into the hazard through the blanked areas of the detection zone.

Floating Blanking

The Floating Blanking mode of operation activates through DIP switch settings in the GuardShield safety light curtain receiver (see Table 20 on page 16). Floating blanking allows one or two beams that are located anywhere in the protective field to be blanked out. For instance, blocked beams are ignored and the GuardShield safety light curtain remains with outputs active.

Table 5 on page 7 depicts the state for the OSSD safety outputs for one and two-beam floating blanking for different situations.

IMPORTANT You cannot activate multiple beam floating blanking on a 30 mm (1.18 in.) resolution GuardShield safety light curtain system.
Actuation of the Floating Blanking mode of operation changes the resolution of the GuardShield safety light curtain.

Table 2 - Effective Resolution [mm (in.)]

GuardShield Safety Light Curtain Resolution	Number of Beams Floated	Effective Resolution
14 (0.55)	1 beam	24 (0.94)
	2 beams	34 (1.34)
30 (1.18)	1 beam	50 (1.97)

Figure 4 - Floating Blanking

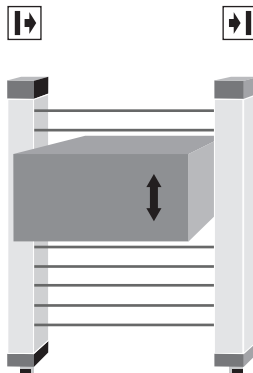

Floating blanking allows an object to float in (move within, or in and out of) the protective field without causing the safety light curtain outputs to change to the off-state.

IMPORTANT After each configuration or reconfiguration of a GuardShield safety light curtain, use the appropriate test piece to test the configuration of the GuardShield safety light curtain.

Table 3 - Description of Symbols

Symbol	Description
○	Beam not interrupted
⊗	Beam interrupted
□	Beam is activated for fixed blanking and not interrupted
⊠	Beam is activated for fixed blanking and interrupted

Table 4 - Status of OSSD Safety Output for Different Situations in Case of Teach-in Fixed Blanking

Case	1	2	3	4	5	6	7	8
Infrared Beam	No Blanking	Fixed Teach-in Blanking						
N	○	○	○	○	○	○	○	○
N+1	○	⊠	⊠	□	⊠	□	⊠	⊠
N+2	⊗	⊠	□	⊠	□	□	⊠	⊠
N+3	○	○	○	○	○	○	○	○
N+4	○	○	○	○	⊗	○	⊠	⊠
N+5	○	○	○	○	○	○	○	⊗
N+6	○	○	○	○	○	○	○	○
Status OSSDs	Off	On	Off	Off	Off	Off	On	Off

Table 5 - Status of OSSD Safety Outputs for Different Uses in Different Cases of Floating Blanking

Case	1	2	3	4	5	6	7	8	9	10	11	12
Infrared Beam	Reduced Resolution Deactivated	Floating Blanking 1 Beam				Floating Blanking 2 Beams						
N	○	○	○	○	○	○	○	○	○	○	○	○
N+1	○	○	⊗	⊗	⊗	○	⊗	⊗	⊗	⊗	⊗	⊗
N+2	⊗	○	○	○	⊗	○	○	○	⊗	⊗	⊗	○
N+3	○	○	○	⊗		○	○	⊗		⊗		⊗
N+4	○	○	○	○	○	○	○	○	○	○	⊗	
N+5	○	○	○	○	○	○	○	○	○	○	○	⊗
N+6	○	○	○	○	○	○	○	○	○	○	○	○
Status OSSDs	Off	On	On	Off	Off	On	On	On	On	Off	Off	Off

Response Time

The response time of the GuardShield safety light curtain depends on the height of the protective field, the resolution, and the coding of the system.

The response time of a cascading system is the response time of the interrupted individual segment-pair response time.

Table 6 - Response Time for Finger Resolution 14 mm (0.55 in.) [mm (in.)]

Resolution	Protective Height	Number of Beams	Response Time w/o Coding	Response Time w/Coding
14 (0.55)	160 (6.3)	16	20 ms	30 ms
14 (0.55)	320 (12.5)	32	20 ms	30 ms
14 (0.55)	480 (18.8)	48	20 ms	30 ms
14 (0.55)	640 (25.1)	64	20 ms	30 ms
14 (0.55)	800 (31.4)	80	20 ms	30 ms
14 (0.55)	960 (37.7)	96	20 ms	30 ms
14 (0.55)	1120 (44.0)	112	20 ms	30 ms
14 (0.55)	1280 (50.3)	128	20 ms	30 ms
14 (0.55)	1440 (56.6)	144	20 ms	30 ms
14 (0.55)	1600 (62.9)	160	25 ms	35 ms
14 (0.55)	1760 (69.2)	176	25 ms	35 ms

Table 7 - Response Time for Hand Resolution 30 mm (1.81 in.) [mm (in.)]

Resolution	Protective Height	Number of Beams	Response Time w/o Coding	Response Time w/Coding
30 (1.18)	160 (6.3)	8	20 ms	30 ms
30 (1.18)	320 (12.5)	16	20 ms	30 ms
30 (1.18)	480 (18.8)	24	20 ms	30 ms
30 (1.18)	640 (25.1)	32	20 ms	30 ms
30 (1.18)	800 (31.4)	40	20 ms	30 ms
30 (1.18)	960 (37.7)	48	20 ms	30 ms
30 (1.18)	1120 (44.0)	56	20 ms	30 ms
30 (1.18)	1280 (50.3)	64	20 ms	30 ms
30 (1.18)	1440 (56.6)	72	20 ms	30 ms
30 (1.18)	1600 (62.9)	80	20 ms	30 ms
30 (1.18)	1760 (69.2)	88	20 ms	30 ms

IMPORTANT Determine stop time: The measurement of stop time (T_s) must include the stop times of all devices in the stop circuit. If you exclude any device and control system elements when you calculate T_s , the result is an inaccurate safety distance calculation.

Determine the Safety Distance

You must mount the safety light curtain with proper safety distance:

- From the point of danger.
- From reflective surfaces.

US Safety Distance Formula



ATTENTION: Mount the GuardShield Type 4 safety light curtains at a sufficient distance from the pinch point or point of operation hazard. A sufficient distance helps maintain that the machine stops before a finger, hand, arm, or body reaches the hazard.

Calculate this distance, referred to as the safety distance, properly before you determine the protective height of the safety light curtain and mount the safety light curtains on the machine. Failure to calculate this safety distance accurately results in operator injury.

IMPORTANT According to EN ISO 13855, regardless of the calculated safety distance, never mount GuardShield Type 4 safety light curtains closer than 100 mm (4 in.) from the point of operation or pinch point hazard.

In the United States, there are two formulas to use to calculate the safety distance. The first, the OSHA formula, is the minimum requirement for the calculation of the safety distance. The second formula, the one we recommend, is the ANSI formula, which incorporates additional factors to consider when calculating the safety distance.

OSHA Safety Distance Calculation Formula

The OSHA safety distance formula as specified in CFR Subpart O 1910.217 is as follows:

$$D_s = 63 \times T$$

D_s	Safety Distance
63	OSHA recommended hand speed constant in inches per second
T	Total stop time of all devices in the safety circuit, which is measured in seconds. This value must include all components that are involved to stop the hazardous motion of the machinery. For a mechanical power press, it is the stop time that is measured at approximately the 90° position of the crankshaft rotation.



WARNING: Not including the response time of a device or devices in the stop time calculation results in insufficient safety distance for the application, which results in operator injury.

IMPORTANT Determining Stop Time: The measurement of stopping time (T_s) must include the stopping times of all devices in the stop circuit. Not including all device and control system elements when calculating T_s results in an inaccurate safety distance calculation.

ANSI Safety Distance Formula

The ANSI safety distance formula, which is the Rockwell Automation® recommended formula, is as follows:

$$D_s = K \times (T_s + T_c + T_r + T_{spm}) + D_{pf}$$

D_s	Minimum safety distance between the safe guarding device and the nearest point of operation hazard, in inches.
K	Hand-speed constant in inches per second. The ANSI standard value is 1600.2 mm (63 in.) per second when the operator begins reaching toward the point of operation hazard from rest. ⁽¹⁾
T_s	Stop time of the machine tool that is measured at the final control element. Measurement starts at maximum machine velocity.
T_c	Response time of the control system
T_r	Response time of the presence sensing device (safety light curtain) and its interface, if any. You must measure the value, or the device manufacturer states the value.
T_{spm}	Additional time is allowed for the stop performance monitor to compensate for variations in normal stopping time T_s . Check ANSI B11.19 Annex D for details.
D_{pf}	Depth penetration factor. It is an added distance to allow for how far into the protective field an object, such as a finger or hand, can travel before being detected. D_{pf} is related to the object sensitivity of the safety light curtain. Object sensitivity (resolution) is the smallest diameter object, which is detected anywhere in the sensing field.

(1) ANSI B11.19 2000 E8.3.2.3 and Annex D states: One of the accepted values for K is the hand speed constant (it is considered as the horizontal motion of the hand and arm while seated). The common value of K is 1.6 m/s (63 in./s), although other values (typically greater) are also used. The hand speed constant excludes other body movements, which can affect the actual approach speed. Consideration of the previous factors must be included when determining the speed constant for a given application. The employer must consider all factors, including the physical ability of the operator, when determining the value of K to be used.

IMPORTANT A stop time measurement device measures $T_s + T_c + T_r + T_{spm}$.

Example Calculation (for US):

In a perpendicular safety light curtain application with object sensitivity (effective resolution) less than 64 mm (2.5 in.), you can approximate the D_{pf} based on the following formula:

$$D_{pf} \text{ (inches)} = 3.4 \times (\text{object sensitivity} - 0.276),$$

But not less than 0.

For GuardShield Type 4 safety light curtain:

Object sensitivity = 30 mm (1.18 in.)

$$D_{pf} = 3.4 \times (1.18 - 0.276 \text{ in.}) = 3.08 \text{ in.}$$

$$T_s = 241 \text{ ms} = 0.241 \text{ s}$$

$$T_c = 10 \text{ ms} = 0.01 \text{ s}$$

$$T_r = 20 \text{ ms} = 0.02 \text{ s}$$

$$T_{spm} = 20\% \text{ of } T_s \text{ (calculated by the machine manufacturer)} = 49 \text{ ms} = 0.049 \text{ s}$$

$$K = 63 \text{ in./s (determined by the machine manufacturer)}$$

$$D_s = 63 \times (0.241 + 0.01 + 0.02 + 0.049) + 3.08 \text{ in.}$$

$$= 63 \times 0.32 + 3.08 \text{ in.}$$

$$= 20.16 + 3.08 \text{ in.}$$

$$= 23.24 \text{ in. (600 mm)}$$

European Safety Distance Formula

A safety distance must be maintained between the safety light curtain and the point of danger. This safety distance helps maintain that the point of danger can only be reached after the dangerous state of the machine is removed.

The safety distance as defined in EN ISO 13855 and EN ISO 13857 depends on:

- Stop/run-down time of the machine. (The machine documentation shows the stop/run-down time, or you must take a measurement to determine the stop/run-down time.)
- Response time of the protective device, for example, GuardShield Type 4 safety light curtain (for [Response Time on page 7](#)).
- Response time of the safety circuit.
- Reach or approach speed.
- Resolution of the safety light curtain.

Figure 5 - Safety Distance from the Point Of Danger

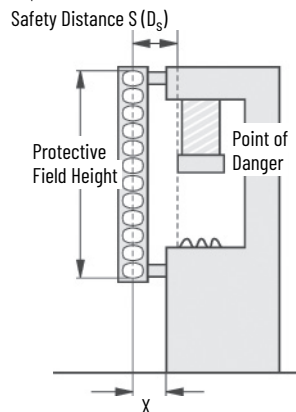

IMPORTANT An operator is not able to stand between the protective field and the point of operation. EN ISO 13855 requires a maximum distance X (see [Figure 5](#)) of $\leq 70 \text{ mm (2.76 in.)}$ at an installation height of 300 mm (11.9 in.). Check EN ISO 13855 for other installation heights.

Calculate the Safety Distance S

According to EN ISO 13855 and EN ISO 13857:

- First, use the following formula to calculate S:
 $S = 2000 \times T + 8 \times (d - 14)$ [mm]

Where:

T = Stop/run-down time of the machine
 + response time of the protective device [s]
 d = Resolution of the safety light curtain [mm]
 S = Safety distance [mm]

The reach/approach speed is already included in the formula.

- If the result S is ≤ 500 mm (19.6 in.), then use the determined value as the safety distance.
- If the result S is > 500 mm (19.6 in.), then recalculate S as follows:
 $S = 1600 \times T + 8 \times (d - 14)$ [mm]
- If the new value S is > 500 mm (19.6 in.), then use the newly determined value as the minimum safety distance.
- If the new value S is ≤ 500 mm (19.6 in.), then use 500 mm (19.6 in.) as the safety distance.

Example Calculation (for Europe)

Stop/run-down time of the machine = 290 ms
 Response time safety circuit = 10 ms
 Response time safety light curtain = 20 ms
 Resolution of the safety light curtain = 30 mm (1.18 in.)
 $T = 290 \text{ ms} + 30 \text{ ms} = 320 \text{ ms} = 0.32 \text{ s}$
 $S = 2000 \times 0.32 + 8 \times (30 - 14) = 768 \text{ mm} (30.24 \text{ in.})$
 $S > 500 \text{ mm} (19.7 \text{ in.})$, therefore:
 $S = 1600 \times 0.32 + 8 \times (30 - 14) = 640 \text{ mm} (25.1 \text{ in.})$

Minimum Distance from Reflective Surfaces

The infrared light from the sender reflects off reflective surfaces and the system receiver receives the light. If this condition occurs, it can result in the non-detection of an object when it enters the sensing field of the GuardShield Type 4 safety light curtain.

All reflective surfaces and objects (for example, material bins) must therefore be at the minimum distance (A) from the protective field of the system. The minimum distance (A) depends on the distance (D) between sender and receiver.

Figure 6 - Minimum Distance from Reflective Surfaces

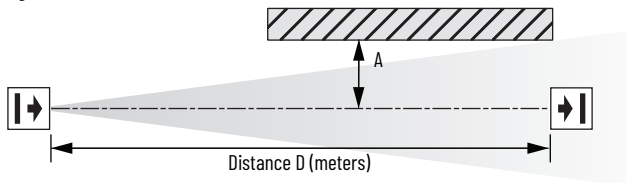

Determine the Minimum Distance from the Reflective Surfaces

- Determine the distance D [m] sender-receiver
- Read the minimum distance A [mm] in [Figure 7](#)

Figure 7 - Minimum Distance from Reflective Surfaces

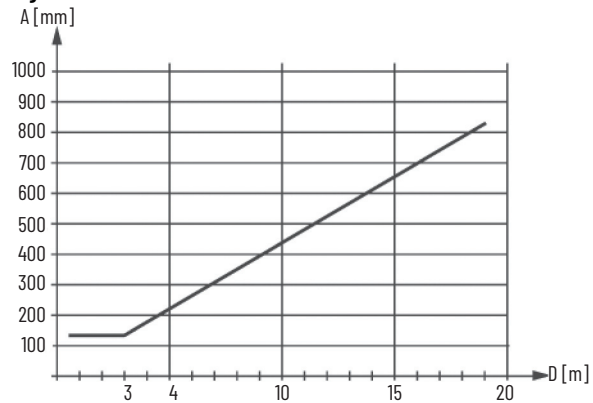

The effective aperture angle for the GuardShield Type 4 safety light curtain system is within $\pm 2.5^\circ$ at a mounting distance of > 3.0 m (9.8 ft). Calculate the minimum distance to reflective surfaces depending on the distance between the transmitter and the receiver. Use an aperture angle of $\pm 2.5^\circ$, or take the appropriate value from [Table 8](#).

Table 8 - Minimum Safety Distance to Reflective Surfaces

Distance between Transmitter and Receiver (Range L) [m (ft)]	Minimum Distance (A) [mm (in.)]
0.2...3.0 (0.65...9.8)	135 (5.31)
4.0 (13.1)	175 (6.88)
5.0 (16.4)	220 (8.66)
6.0 (19.6)	265 (10.43)
7.0 (22.9)	310 (12.2)
10.0 (32.8)	440 (17.32)
16.0 (52.4)	700 (27.55)

Installation and Mounting

This section describes the preparation, selection, and installation of the GuardShield safety light curtain.

The standard GuardShield safety light curtain has an amber status indicator in the receiver (see [Figure 26 on page 17](#)), to use as an alignment aid. This status indicator flashes when the receiver sees the infrared light from the transmitter. This status indicator turns off when optimal alignment is attained.

Standard Alignment Procedure

Mount and connect both transmitter and receiver. The transmitter and receiver must be:

- Parallel to each other
- Positioned at the same height
- Connected to the same end (see [Figure 8](#))

Figure 8 - Inverse Mounting

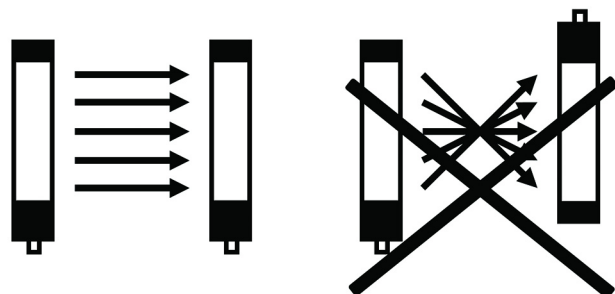

1. Turn on power to the GuardShield safety light curtain system.
2. Rotate the transmitter and watch the amber status indicator on the receiver (see [Figure 26 on page 17](#)); find the points where the indicator changes from on (amber) to off.
3. Determine the maximum left and right-turn angles and position the unit in the center.
4. Tighten all hardware to fix the alignment.
5. Then perform the same alignment procedure with the receiver.
6. Cycle power to confirm that the system powers up and goes to the on-state (alignment indicator is off).

The GuardShield safety light curtain is also available with an integrated laser alignment system. This alignment system has a constant low-powered Class 1, eye-safe laser in the top of the transmitter and in the bottom of the receiver. Each laser emits a low level of visible light. Simply block this light below the finger symbol to cause the light to reflect back to a photo sensor, which changes the condition of the laser light to high powered. If this light is at a low level, interruption causes the laser to emit a highly visible level of light. Interruption of the visible light in the same location causes the laser to switch to a low level of emission. The emission of visible light also changes to a low level after 5 minutes of activation.

Across from each laser is a target to help with the alignment of the GuardShield safety light curtain pair. Position the visible light in the center of the top and bottom targets for optimal alignment of the GuardShield safety light curtain pair.

External laser 440L-ALAT and mounting bracket 450L-ALAT-C are accessories for aligning the GuardShield safety light curtain without integrated laser alignment (see [Laser Alignment Tool on page 29](#)).

Integrated Laser Alignment Procedure

1. Properly locate the GuardShield safety light curtain pair from the point of operation hazard, after you calculate the safety distance.
2. Use the GuardShield safety light curtain mounting brackets to mount the transmitter and receiver so that they face one another and are positioned in the same direction (see [Figure 8](#)). For reference, the status indicators are opposite one another.

Place a finger or hand in front of each laser to turn on the laser.

For optimal alignment, adjust the transmitter and receiver so that both visible laser beams meet the laser targets opposite each laser. A small deviation around the target is allowable.

The GuardShield safety light curtain is suitable for most operating environments (IP65 environmental rating). Observe proper safety distance and adequate protective height.

IMPORTANT Install the GuardShield safety light curtain so that access to the hazard is only possible through the sensing field of the GuardShield safety light curtain. To meet this requirement, auxiliary safe guarding can be required with the GuardShield safety light curtain.

Determine if the machinery, on which the GuardShield safety light curtain is mounted, meets the requirements as specified in [Safety Precaution on page 2](#). That is, machinery must be able to stop anywhere in its stroke or cycle, consistently and repeatedly.

Correct Installation

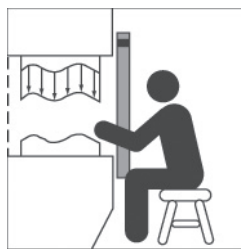

Operators cannot reach hazardous machine parts without passing through the protective field.

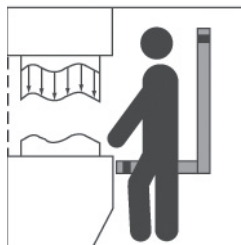

Operators must not step between protective field and hazardous machine parts (by-pass prevention).

Incorrect Installation

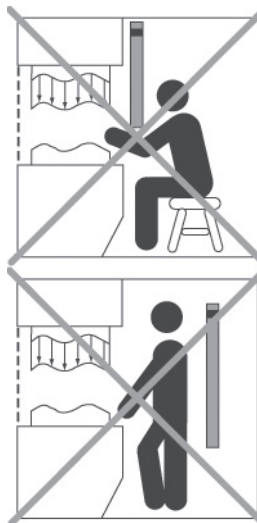

Operators can reach hazardous machine parts without passing through the protective field.

Operators can step between protective field and hazardous machine parts.

You must mount the GuardShield safety light curtain at the proper distance from the point of operation hazard. This distance is referred to as the safety distance.

Figure 9 - Determine Machine Stopping Time and Safety Distance

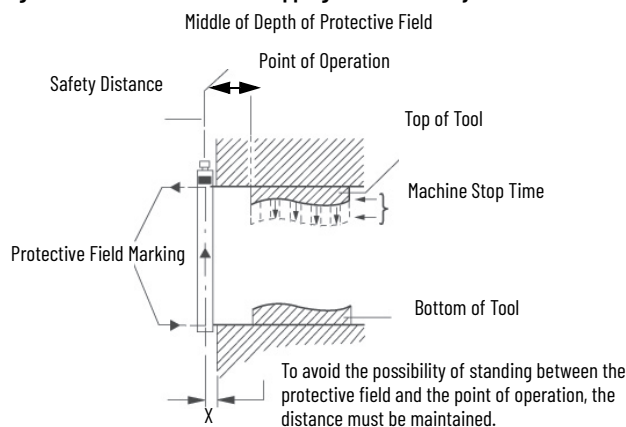

IMPORTANT You are not able to stand between the protective field and the point of operation. EN ISO 13855 requires a maximum distance X (see [Figure 9](#)) of ≤ 70 mm (2.76 in.) at an installation height of 300 mm (11.9 in.). Check EN ISO 13855 for other installation heights.

Configuration of Operating Modes in Cascading Systems

You can configure all operating modes of a standard GuardShield safety light curtain in the host or first segment in a cascading GuardShield safety light curtain system. Middle and end segments can only have the following operating modes/features configured.

- Beam coding
- Floating blanking
- Fixed blanking

All other possible operating modes of a standard GuardShield safety light curtain, if configured in a middle or end segment, cause lockout or off conditions. This condition requires the cycling of power and a reconfiguration of the segment.

Two-segment Cascading Systems

If the GuardShield safety light curtain pair is mounted vertically so that a person can stand between the vertical pair and the machine hazard, a means of detection of that person is required.

There are several methods to detect the presence of a person who is standing in front of the machine hazard, but inside of the safety light curtain. Possible solutions include the installation of a safety mat or safety laser scanner. However these solutions are costly as they are separate safety systems that integrate into the safety circuit. The most cost-effective solution is to interconnect an additional safety light curtains in series to the vertical pair. Select a host or cascade pair of GuardShield safety light curtains with a protective height and resolution that is based on the results of a risk assessment. Then select the horizontal protective height of the pair of safety light curtains. This pair provides detection from the vertical pair to the front of the machine hazard. Typically, this pair of safety light curtains can have a 30 mm (1.18 in.) resolution, as their purpose is to detect the presence of a person and not fingers.

Next, select the interconnected patchcords for the transmitter and receiver. These patchcords are offered in various lengths. Finally, determine if the last segment of the cascading system is a standard or cascading GuardShield safety light curtain pair. Cascade segments that are not connected to another pair of GuardShield safety light curtains must have a termination plug that is attached to the receiver segment.

Figure 10 - Example for a Setup with Two Cascaded Segments (L-shape Setup)

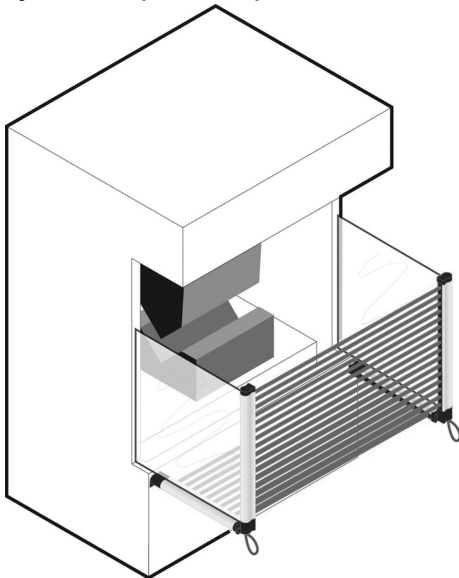

L-shaped two-segment GuardShield safety light curtain cascade systems offer protection when it is possible to stand between the vertical safety light curtain and the machine hazard.

Three-segment Cascading Systems

When the use of corner mirrors is not practical or possible, use cascading GuardShield safety light curtains to create three-sided guarding of a machine hazard.

Figure 11 - Top and Bottom Mounting of Three GuardShield Safety Light Curtain Segments (U-shape Setup)

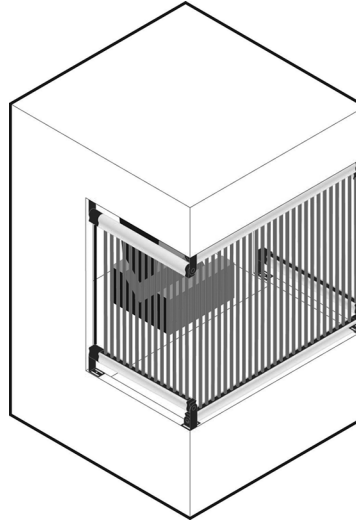

Top and bottom mounting of three GuardShield safety light curtain segments is possible. This configuration provides three-sided machine guarding without the use of corner mirrors.

Mount and Align Cascading GuardShield Safety Light Curtain

IMPORTANT You must align cascade segments in a particular order. First, align the last segment in the system. Once the last receiver status indicator is green, secure the mounting brackets of that pair. Next, align the middle segment pair. When the middle-segment receiver status indicator is green, secure those brackets. Finally, align the host segment. When that receiver status indicator is green, secure those brackets.

To test the system, interrupt the sensing field of the last segment and verify that all receiver OSSD status indicators are red.

Next, interrupt the sensing field of the middle segment pair (if any) and confirm that the middle segment and host segment receiver OSSD status indicators are red. The last segment-pair receiver status indicator remains green. Finally, interrupt the sensing field of the host segment receiver and confirm that the receiver OSSD status indicators are red (middle and end segment pairs indicate green).

Multiple GuardShield Safety Light Curtains

When you mount two or more GuardShield safety light curtains close to one another, the receiver of one pair can receive infrared light from the transmitter of another pair. The GuardShield safety light curtain feature of beam coding overcomes this optical interference. Beam coding changes the pulse pattern of infrared light that a GuardShield safety light curtain transmitter emits.

Figure 12 - Multiple GuardShield Safety Light Curtain Alignment Options

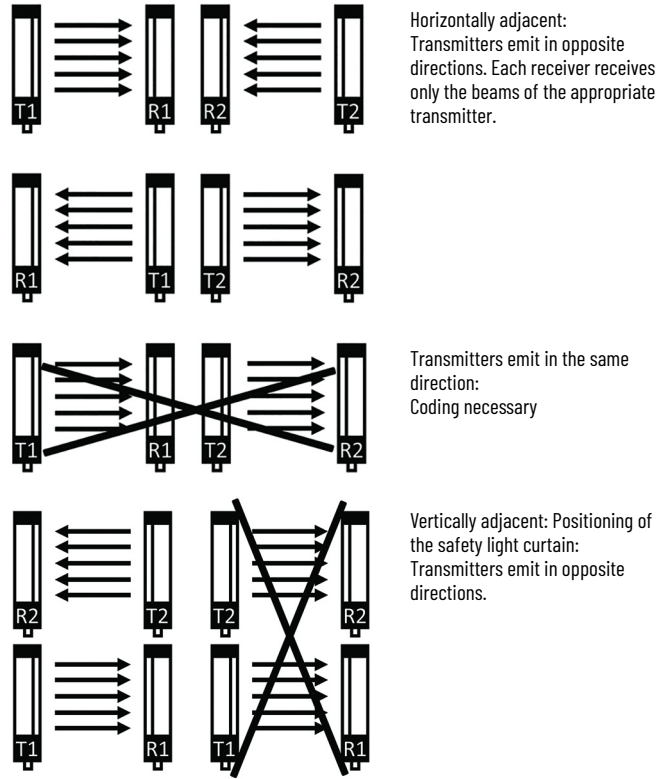
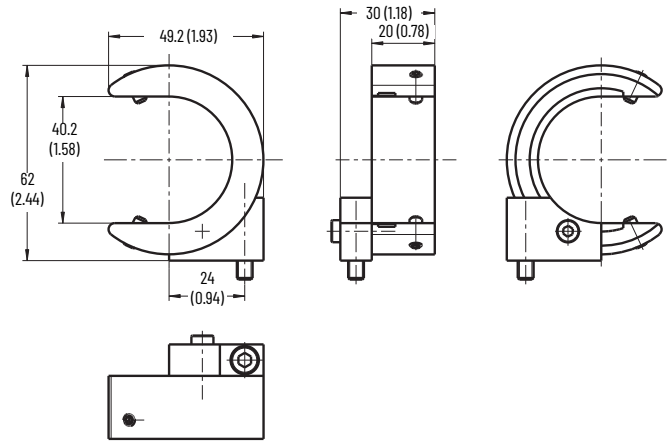
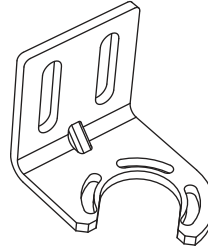

Figure 14 - Optional Middle Mounting Bracket 440L-AF6108



Use middle mounting brackets in vibration applications for protective heights of 1120 mm (44.09 in.) and larger.

Figure 15 - Remote Teach Receiver Bracket (a)



Mounting Brackets

By default, the GuardShield safety light curtain mounts using right angle brackets (see [Figure 13](#)) that attach to the endcaps of both transmitter and receiver. Use additional brackets, if necessary (see [Figure 14](#)), to mount the GuardShield safety light curtain at a proper safety distance from the machinery hazard. For applications with shock and/or vibrations, also see [Table 35 on page 30](#).

Figure 13 - Mounting Brackets AF-6101

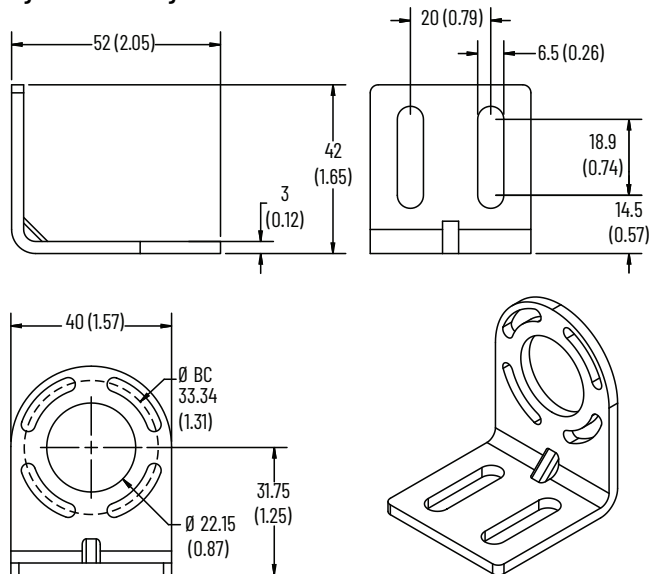

Electrical Installation

The external voltage supply (+24V DC) must meet the requirements of IEC 61496-1. In addition, the following requirements must be fulfilled.

- The power supply bridges a short-term power failure of 20 ms.
- The power supply has double insulation between the primary and the secondary side.
- Helps protect the power supply against overload.
- The power supply corresponds to the guidelines of the EWG (industrial environment).
- The power supply corresponds to the Low Voltage Directives.
- The grounded conductor of the power supply device must be connected to a grounded conductor PE.
- The maximum deviation of the voltage levels is 24V DC \pm 20%.

(a) See [Remote Teach on page 23](#).

EDM Connection

Figure 16 - Connect the Contact Elements to the EDM (a)

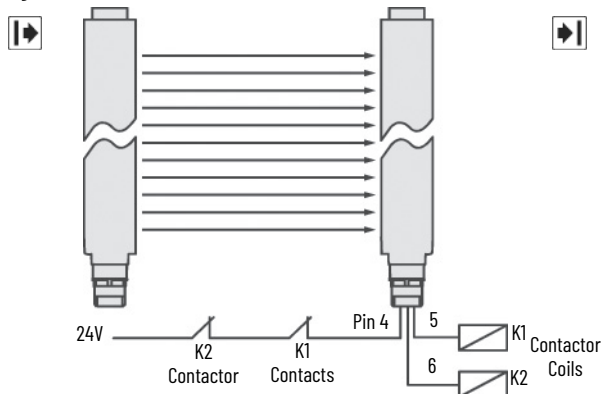

IMPORTANT Not available for GuardShield safety light curtain with ArmorBlock Guard I/O module connectivity.

Figure 17 - Connecting the Reset/Restart Button (b)

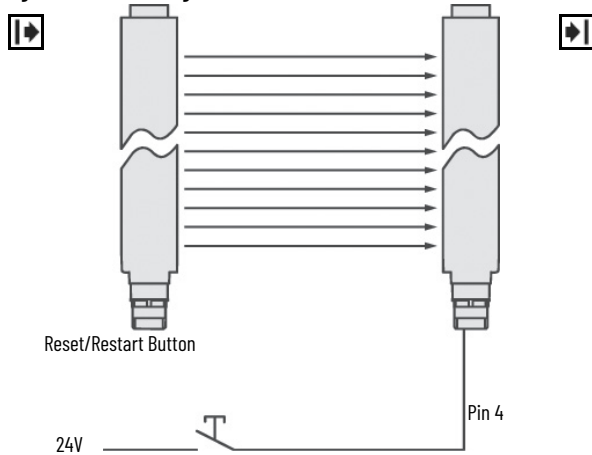

IMPORTANT Not available for GuardShield safety light curtain with ArmorBlock Guard I/O module connectivity.

Cables and Connectors

Figure 18 - Standard Connector [mm (in.)]

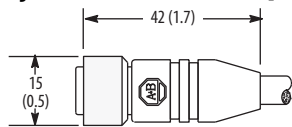

The GuardShield safety light curtain transmitter connector is a 4-pin DC micro connector that we offer in cable lengths of 2...30 m (6.56...98.4 ft). The GuardShield safety light curtain receiver connector is an 8-pin DC micro connector that we offer in cable lengths of 2...30 m (6.56...98.4 ft).

Table 9 - Standard and ArmorBlock Guard I/O Module Transmitter Connection

Top View - Concave DC Micro ⁽¹⁾	Color	Pin No.	Signal
			Transmitter
	Brown	1	+24V DC
	White	2	No connection
	Blue	3	0V DC
	Black	4	Machine test signal

(1) The transmitter must not connect to the ArmorBlock Guard I/O module.

Table 10 - Standard Receiver Connector

Top View - Concave DC Micro	Color	Pin No.	Signal
			Receiver
	White	1	Auxiliary output
	Brown	2	+24V DC
	Green	3	Ground
	Yellow	4	EDM
	Gray	5	OSSD 1
	Pink	6	OSSD 2
	Blue	7	0V DC
	Red	8	Start/restart

Table 11 - Receiver Connector for ArmorBlock Guard I/O Module Connectivity

Top View	Color	Pin No.	Signal
			Receiver
	Brown	1	+24V
	White	2	OSSD 2
	Blue	3	0V
	Black	4	OSSD 1
	Gray	5	NC

Table 12 - Patchcord Connectors - Cascading Segments

Cat. No. ⁽¹⁾	Description [m (ft)]
Transmitter Patchcord Connectors	
889D-F4HLD-0M3	4-pin M12 patchcord, 0.3 (0.98)
889D-F4HLD-1	4-pin M12 patchcord, 1 (3.28)
889D-F4HLD-2	4-pin M12 patchcord, 2 (6.56)
Receiver Patchcords Connectors	
889D-F8ABD-0M3	8-pin M12 patchcord, 0.3 (0.98)
889D-F8ABD-1	8-pin M12 patchcord, 1 (3.28)
889D-F8ABD-2	8-pin M12 patchcord, 1 (3.28)
Receiver	
898D-81CU-DM	Termination plug 8-pin M12 quick-disconnect

(1) The last cascading pair in a cascade system or standalone pair of GuardShield safety light curtains requires a shorting/termination plug.

Figure 19 - Example of Patchcord

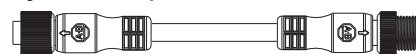

Host Patchcords and Connectors

The GuardShield safety light curtain transmitter host patchcord has 4-pin DC micro-over-molded quick-disconnect connectors that we offer in lengths of 0.3 m (0.98 ft), 1 m (3.28 ft), and 2 m (6.56 ft). The GuardShield safety light curtain receiver host patchcord has 8-pin DC micro-over-molded quick-disconnect connectors that we offer in lengths of 0.3 m (0.98 ft), 1 m (3.28 ft), and 2 m (6.56 ft).

(a) See [Relay Monitoring \(MPCE/EDM\)](#) on page 4.

(b) See [Start Interlock](#) and [Restart Interlock \(Manual Reset\)](#) on page 4.

Figure 20 - Quick-disconnect Connector [mm (in.)]

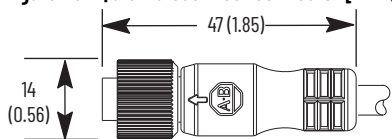

Table 13 - 8-pin Receiver Pinouts

Top View	Color	Pin No.	Signal
			Receiver
	White	1	Auxiliary Output
	Brown	2	+24V DC
	Green	3	Ground
	Yellow	4	EDM
	Gray	5	OSSD 1
	Pink	6	OSSD 2
	Blue	7	0V DC
	Red	8	Start/Restart

Table 14 - ArmorBlock Guard I/O Pinouts

Top View	Color	Pin No.	Signal
			Receiver
	Brown	1	+24V
	White	2	OSSD 2
	Blue	3	0V
	Black	4	OSSD 1
	Gray	5	NC

Table 15 - Patchcord Connectors - Cascading Segments

Cat. No.	Description [m (ft)]
Transmitter Patchcord Connectors	
889D-F4HLD-0M3	4-pin M12 patchcord, 0.3 (0.98)
889D-F4HLD-1	4-pin M12 patchcord, 1 (3.28)
889D-F4HLD-2	4-pin M12 patchcord, 2 (6.56)
Receiver Patchcord Connectors	
889D-F8ABDM-0M3	8-pin M12 patchcord, 0.3 (0.98)
889D-F8ABDM-1	8-pin M12 patchcord, 1 (3.28)
889D-F8ABDM-2	8-pin M12 patchcord, 1 (3.28)

Figure 21 - Termination Plug - Cascadable 8-pin Receiver



Table 16 - Patchcords Connectors - ArmorBlock I/O Connection

Cat. No.	Description [m (ft)]
889D-F5ACDM-0M3	5-pin M12 patchcord, 0.3 (0.98)
889D-F5ACDM-1	5-pin M12 patchcord, 1 (3.28)
889D-F5ACDM-2	5-pin M12 patchcord, 2 (6.56)
889D-F5ACDM-5	5-pin M12 patchcord, 5 (16.4)
889D-F5ACDM-10	5-pin M12 patchcord, 10 (32.81)

Table 17 - Termination Plug - Cascadable 5-pin ArmorBlock I/O

Cat. No. (1)	Description
898D-418U-DM	Termination plug, 5-pin M12 receiver quick disconnect

(1) The top receiver connector, if used as a standalone pair or the last segment pair in a cascadable system, requires the termination plug.

IMPORTANT The transmitter and receiver use the same 5-pin patchcords. Select one catalog number for each.

Table 18 - Cable Connectors for Receiver

Cat. No.	Description [m (ft)]
889D-F8AB-2	8-pin DC micro straight concave cordset, 2 (6.5)
889D-F8AB-5	8-pin DC micro straight concave cordset, 5 (16.4)
889D-F8AB-10	8-pin DC micro straight concave cordset, 10 (32.8)
889D-F8AB-15	8-pin DC micro straight concave cordset, 15 (49.2)
889D-F8AB-20	8-pin DC micro straight concave cordset, 20 (65.6)
889D-F8AB-30	8-pin DC micro straight concave cordset, 30 (98.4)
889D-R8AB-2	8-pin/8-wire DC micro right angle concave cordset, 2 (6.5)
889D-R8AB-5	8-pin/8-wire DC micro right angle concave cordset, 5 (16.4)
889D-R8AB-10	8-pin/8-wire DC micro right angle concave cordset, 10 (32.8)
889D-R8AB-15	8-pin/8-wire DC micro right angle concave cordset, 15 (49.2)
889D-R8AB-20	8-pin/8-wire DC micro right angle concave cordset, 20 (65.6)
889D-R8AB-30	8-pin/8-wire DC micro right angle concave cordset, 30 (98.4)

Table 19 - Cable Connectors for Transmitter

Cat. No.	Description [m (ft)]
889D-F4AC-2	4-pin DC micro straight concave cordset, 2 (6.5)
889D-F4AC-5	4-pin DC micro straight concave cordset, 5 (16.4)
889D-F4AC-10	4-pin DC micro straight concave cordset, 10 (32.8)
889D-F4AC-15	4-pin DC micro straight concave cordset, 15 (49.2)
889D-F4AC-20	4-pin DC micro straight concave cordset, 20 (65.6)
889D-F4AC-30	4-pin DC micro straight concave cordset, 30 (98.4)
889D-R4AC-2	4-pin DC micro right angle concave cordset, 2 (6.5)
889D-R4AC-5	4-pin DC micro right angle concave cordset, 5 (16.4)
889D-R4AC-10	4-pin DC micro right angle concave cordset, 10 (32.8)
889D-R4AC-15	4-pin DC micro right angle concave cordset, 15 (49.2)
889D-R4AC-20	4-pin DC micro right angle concave cordset, 20 (65.6)
889D-R4AC-30	4-pin DC micro right angle concave cordset, 30 (98.4)

Typical Wiring

Figure 22 - Direct to Contactors with EDM

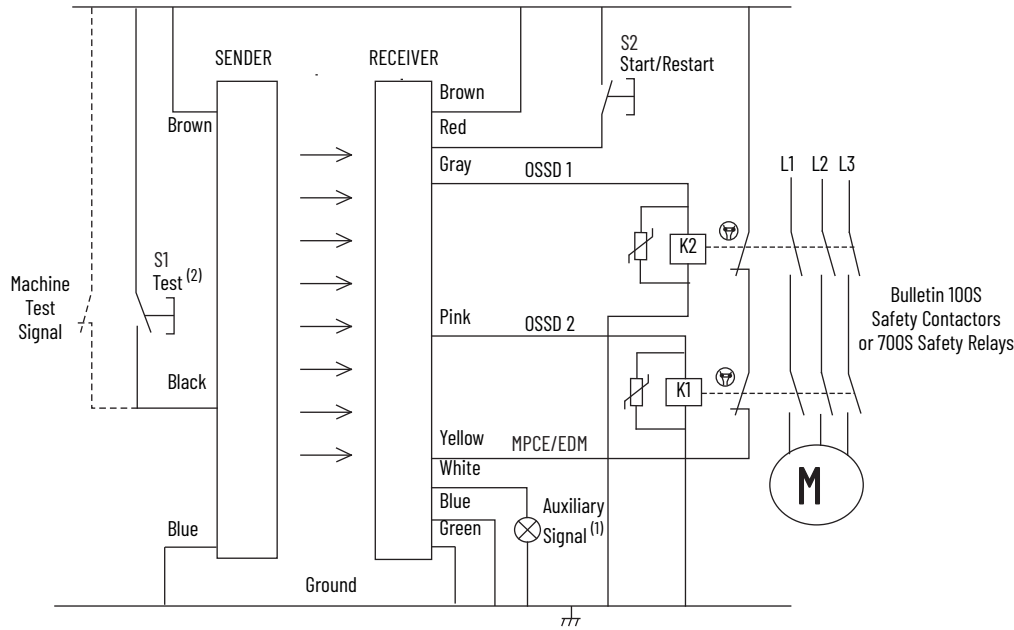

(1) Non-safety auxiliary output (white) can connect to a lamp, motor, or status to a PLC.
 (2) Only connect S1 test based on risk assessment.

IMPORTANT If MPCE/EDM is activated in the GuardShield safety light curtain, the application requires a safety contactor. If MPCE/EDM is not used, K1 and K2 are standard contactors.

Figure 23 - To MSR127 Safety Relay Module

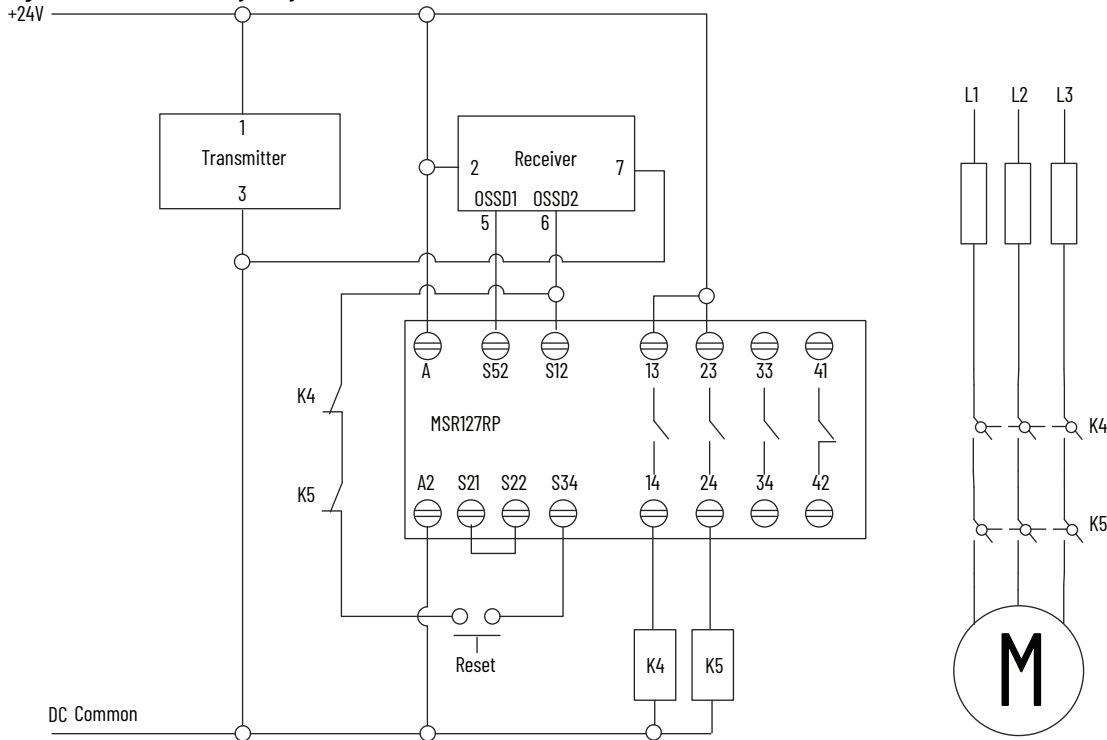

System Configuration

Figure 24 - DIP Switch Selection Settings - Transmitter

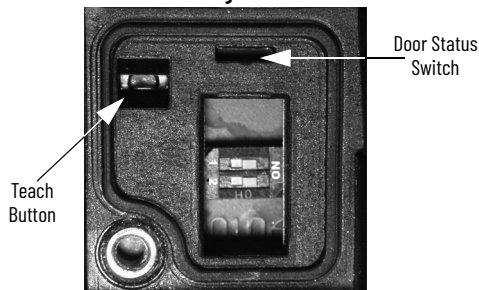
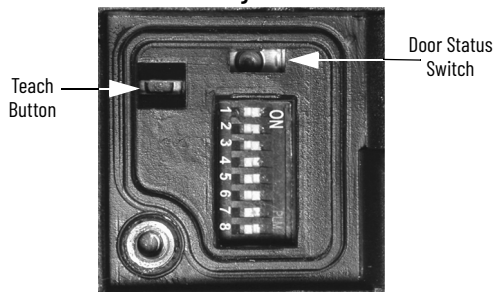

Figure 25 - DIP Switch Selection Settings - Receiver



After you mount, electrically connect, and align the GuardShield safety light curtain, configure your system.

To begin system configuration, use the security tool that is provided to loosen the screw in the configuration door.

IMPORTANT The configuration door screw is a captive screw. The transmitter can only be configured for beam coding and Machine Test Signal. If neither of these configurations are required, then only configure the GuardShield safety light curtain receiver.

Identify and set the appropriate DIP switches for the configuration desired.

DIP switch identification and functions are explained in [Table 20](#)...[Table 22](#).

Follow [Teach-in Procedure Function on page 17](#) to reconfigure the GuardShield safety light curtain.

IMPORTANT After each reconfiguration of the GuardShield safety light curtain, test the system for proper configuration and operation before placing the guarded machine in operation.

Factory Settings

Table 20 - Receiver

Switch	Switch Function	Default Setting	Description
1	Mode activation	On	Guard only (see Table 22)
2	Combination activates one of the following modes: Guard Only, Start Interlock, Restart Interlock	On	
3	MPCE/EDM monitoring disable	On	EDM disabled
4	Teach-in fixed blanking activate	Off	Teach-in fixed blanking disabled
5	Floating blanking activate - single beam	Off	Switches 5 and 6 cannot activate on simultaneously.
6	Floating Blanking activate - two beams	Off	
7	Set beam coding	Off	Beam coding disabled (this setting must match the setting of switch 1 in Table 21 .)
8	Not used	Off	—

Table 21 - Transmitter

Switch	Switch Function	Default Setting	Description
1	Set beam coding	Off	Disabled (this setting must match the setting of switch 7 in Table 20 .)
2	Machine test signal	Off	Off: TX stops transmitting when signal is high. Do not connect or connect N.O. On: Signal low active. Connect N.C.

Table 22 - Settings for Mode of Operation - Receiver

Switch 1	Switch 2	Condition	Operation
On	On	Guard only (automatic reset)	On/off operation
Off	On	Start interlock (push-button reset)	Only interlock at startup. Reset by actuation of the push-button switch. After the first manual reset, guard only (automatic reset) is active.
Off	Off	Restart interlock (manual reset)	Interlock at interruption of sensing area. Reset by manual activation of the push-button switch.
On	Off	Start interlock	Interlock at startup. Reset by interruption/restoration of sensing area for < 1 sec.



ATTENTION: Store every modification at the DIP switches in the memory of the device through the [Teach-in Procedure Function on page 17](#).

IMPORTANT GuardShield safety light curtains with ArmorBlock Guard I/O module connectivity have receiver DIP switches 1, 2, and 3 disabled. The configurable features fixed blanking, floating blanking, and beam coding are allowed for this GuardShield safety light curtain.

Cascading Segment DIP Switch Settings

Some operating modes cannot be configured in the middle and end segments of a cascading GuardShield safety light curtain system. The following operating modes if configured cause the safety light curtain to fault.

- EDM
- Start and restart interlock

To deactivate the mode, cycle power and reteach the segment pair.

IMPORTANT Configuration of the EDM in a middle or end segment causes an EDM fault in that configured segment, even if the EDM is also configured and functions in the host segment. Interruption of the middle or end segment, which has EDM also configured, causes the middle or end segment to go to a lockout condition. To reset the condition, you must cycle power and reconfigure the middle or end segment without the non-allowed configuration.

Configuration of the start or restart interlock in the middle or end segment causes a fault in the middle or end segment, which has that Operating mode configured. The status indicator shows a Waiting for Reset fault, which cannot be reset, even if the host segment is also configured for the start or restart interlock. Due to the lack of an internal reset line in the middle or end segment, you cannot reset the middle or end segment before you reset the host segment.

Teach-in Procedure Function

1. Open the cover of the end cap
 - Receiver: The red status indicator flashes (OSSD off)
 - Transmitter: The orange status indicator flashes (POWER on). See [Figure 26 on page 17](#).
2. Select the desired DIP switch setting.
3. Press and hold the Teach button. The yellow status indicator starts flashing at 10 Hz (10x per second):
 - RX: Blanking indicator

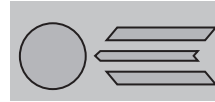

- TX: Emitting indicator



4. After 5 seconds, the status indicator stops flashing. After the indicator stops flashing, release the Teach button within 2 seconds. After three flashes of the yellow status indicator, the function is active.
5. Close and secure the cover. The indicator stops flashing.

The doors on the transmitter and receiver must be closed for the GuardShield safety light curtain to operate.

IMPORTANT If the GuardShield safety light curtain teach procedure is not properly completed, the unit remains in the previous operating mode. Once the teach function is complete and the door is secured, verify that the operating mode has changed to the intended mode.

Figure 26 - Status Indicator at Transmitter (Tx) and Receiver (Rx)

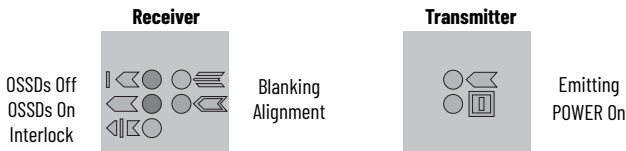

Table 23 - System Status Indicators

Condition No. ⁽¹⁾	Receiver Status Indicators					Transmitter Status Indicators	
	OSSDs Off Red	OSSDs On Green	Blanking Yellow	Alignment Amber	Interlock Yellow	Power On Amber	Emitting Yellow
1	Off	On	Off	Off	Off	On	On
2	On	Off	Off	Off	Off	On	On
3	On	Off	Off	On	Off	On	On
4	On	Off	Off	Off	On	On	On
5	Off	On	On	Off	Off	On	On
6	Off	On	Flash ⁽²⁾	Off	Off	On	On
7	On	Off	Off	Off	Off	On	Off
8	Flash ⁽²⁾	Off	Off	Off	Off	On	On
9	On	Off	Off	Off	Off	Flash ⁽²⁾	On
10	Flash ⁽²⁾	Off	Off	On	Off	On	On
11	Flash ⁽²⁾	Off	Off	Off	On	On	On
12	Flash ⁽²⁾	Off	Data Trans	Off	Off	On	On
13	On	Off	Off	Off	Off	Flash ⁽²⁾	Data Trans

(1) Conditions 8...13 are fault conditions.

(2) Flash rate is approximately 2 Hz (two times per second).

Table 24 - Conditions

Condition No. (1)	Description
1	Guard Only (automatic reset) mode, safety light curtain unobstructed (aligned, not in interlock)
2	Guard Only (automatic reset) mode, safety light curtain interrupted (aligned, not in interlock)
3	Guard Only (automatic reset) mode, misaligned (not in interlock)
4	Guard Only (automatic reset) mode, in start or restart interlock (aligned)
5	Fixed Blanking mode (aligned, not in interlock)
6	Floating or Floating/Fixed Blanking mode (aligned, not in interlock)
7	Transmitter test input active (pin 4)
8	Internal fault, receiver
9	Internal fault, transmitter
10	External fault (OSSD short to ground, +V, or cross connection)
11	External fault (MPCE/EDM error)
12	Configuration mode (receiver access door open)
13	Configuration mode (transmitter access door open)

(1) For fault conditions 8...13, see [Troubleshooting Guide on page 19](#).



ATTENTION: Confirm that all power to the machine, and the safety system is disconnected during electrical installation.

Checklist

IMPORTANT Before power-up and initiation of the GuardShield safety light curtain system, complete the following checklist.

Cable check before initiation:

- The power supply is a 24V DC device, which must comply with all applicable standards of the Machinery Directive 2006/42/EC, and the product standard (IEC 61496).
- Proper polarity of the power supply at the GuardShield safety light curtain.
- The transmitter connection cable properly connects to the transmitter, the receiver connection cable properly connects to the receiver.
- Confirm the double insulation between the safety light curtain output and an external potential.
- The OSSD outputs are not connected to +24V DC.
- The connected switching elements (load) do not connect to 24V DC.
- No connection to a conventional power supply.
- If two or more GuardShield safety light curtains are in use, verify that each system is properly installed, to avoid optical interference.

Switch on the GuardShield safety light curtain and observe the following to check its function.

- If the protective field is free of obstructions, 2 seconds after switching on, the system works properly.

Safety Instructions and Maintenance



ATTENTION: Never operate the GuardShield safety light curtain before you conduct the following inspection. Improper inspection can lead to serious or even deadly injury.

- For safety reasons, record all inspection results.
- Only persons who clearly understand the functioning of the GuardShield safety light curtain and of the machine can conduct an inspection.
- If the installer, planning engineer, and operator are different people, confirm that they have sufficient information available to conduct the inspection.

Daily Inspection

- Approach to hazardous machine parts must only be possible through passage through the protective field of the GuardShield safety light curtain.
- Operators cannot step through the sensing area while working on dangerous machine parts.
- The safety distance of the application is bigger than the calculated value.
- The optic front cover is not scratched or dirty.

Operate the machine and check that the hazardous movement stops under the following circumstances.

- The protective field is interrupted.
- The hazardous movement stops immediately if you interrupt the protective field by placing the test rod directly:
 - In front of the transmitter
 - In front of the receiver
 - In between the transmitter and receiver
- No hazardous machine movement while the test rod is anywhere within the protective field.
- The power supply of the GuardShield safety light curtain is turned off.
- If the blanking function is active, check all sections of the protective field with the appropriate test rod (see [Figure 27](#)).

IMPORTANT If any of the previously described conditions do not stop the hazardous motion of the machine, do not allow the protected machine to be placed in operation.

Figure 27 - Proper Testing of Protective Field Using Test Rod

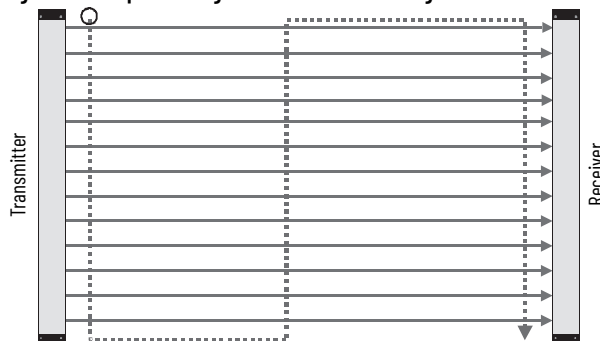

6-month Inspection

Check the following items every 6 months or whenever a machine setting was changed.

1. Machine stops or does not obstruct any safety function.
2. The latest machine or connection modifications have no effect on the control system.
3. The outputs of the GuardShield safety light curtain properly connect to the machine.
4. The total response time of the machine is shorter than the calculated value.
5. Cables and plugs of the GuardShield safety light curtain are in flawless condition.
6. Mounting brackets, caps and cables are tightly secured.

Clean the Optic Front Cover

If the optic front cover of the GuardShield safety light curtain is dirty, the outputs of the GuardShield safety light curtain turn off. Use a clean, soft cloth and rub without pressure. Do not apply aggressive, abrasive, or gritty cleaning agents, which can attack the surface.

Date Code

Figure 28 - Product Label for Units Produced Before 2017

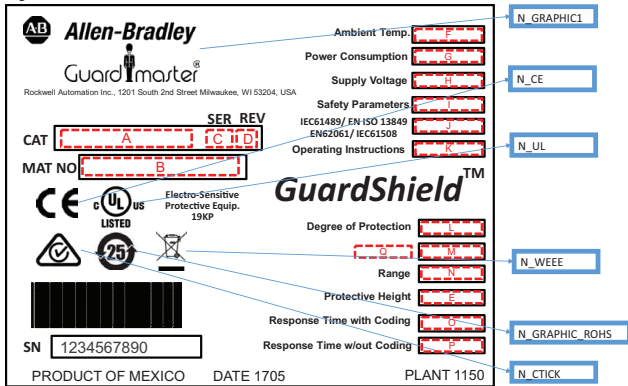

Items that are marked in [Figure 28](#):

- Serial number
- Production data code

Use the codes in [Table 25](#) for older GuardShield safety light curtain units that do not have the date printed on the label.

Table 25 - Explanation of Data Code for Units Produced Before 2017

Location of Manufacture [XX]	Year of Manufacturer [X]	Week of Manufacturer [XX]
M or 4K ⁽¹⁾	J=2004 K=2005 L=2006 M=2007 N=2008 P=2009 R=2010	S=2011 T=2010 U=2013 V=2014 W=2015 Y=2016 Z=2017
		02

(1) M represents Manchester.
4K replaces NH for Monterrey, Mexico.

Figure 29 - Product Label for Units After January 2017

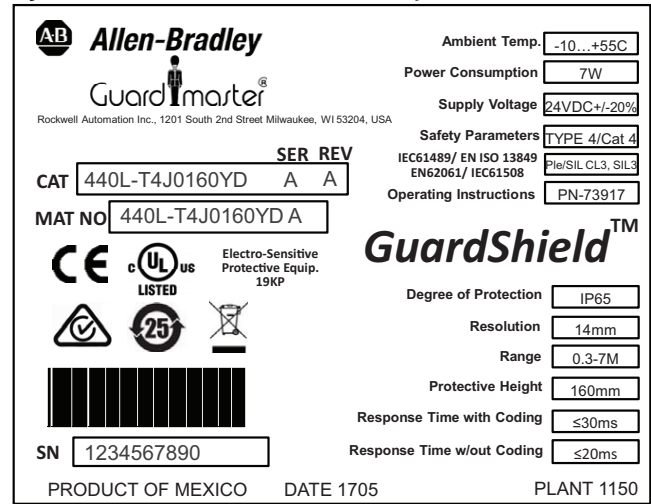

Items that are marked in [Figure 29](#):

- Serial number
- Production data code format: YYWW (YY = year, WW = week)
Example: Date = 1705 (17 = Year - 05 = Week)

Troubleshooting Guide

The safety light curtain conducts an internal self-test after startup. If an error occurs, an appropriate signal combination is sent through the status indicators to the transmitter and receiver.

Table 26 - Error Descriptions

Condition No.	Error Description	Action
8	Internal fault, receiver	<ul style="list-style-type: none"> • Check configuration of transmitter and receiver • Replace receiver
9	Internal fault, transmitter	<ul style="list-style-type: none"> • Check configuration of transmitter and receiver • Check protective field transmitter/receiver • Check connections transmitter/receiver • Exchange transmitter
10	External fault	<ul style="list-style-type: none"> • Check connections of OSSD outputs for short circuit against +24V DC and GND (cable, connected devices) • Exchange receiver
11	External fault (MPCE/EDM error) The function relay monitoring activates and after clearing the OSSD, the input relay monitoring does not recognize a change of state.	<ul style="list-style-type: none"> • Check connection Relay monitoring • Check connected relay for closed contact (if OSSD on—input Relay monitoring must have GND level, if OSSD off—input Relay monitoring must have +24V) • Switch on only after power off/on
12	Configuration mode (receiver)	<ul style="list-style-type: none"> • Cover for DIP switch setting at the receiver is open
13	Configuration mode (transmitter)	<ul style="list-style-type: none"> • Cover for DIP switch setting at transmitter is open

Catalog Number Explanation

Table 27 - GuardShield Standard Safety Light Curtain and Cascading without Laser Alignment System

440L		P	4	K	0320	Y	D
a		b	c	d	e	f	g

a		b		c		d		e		f		g		
Code	Description	Code	Description	Code	Description	Code	Description	Code	Description	Code	Description	Code	Description	
440L	Bulletin number	P	Pair	4	Type 4 Category	J	14 mm (0.55 in.)	0160	Code = mm ⁽¹⁾	Y	IP65 Environmental rating	A	5-pin M12 ⁽²⁾	
		T	Transmitter			K	30 mm (1.18 in.) Resolution	0320					D	Micro QD
		R	Receiver (standard)					0480					R	Remote teach pigtail Connector
		C	Host, pair					0640						
		G	Host transmitter					0800						
		F	Host receiver (cascading) Unit type					0960						
								1120						
								1280						
								1440						
								1600						
								1760						

(1) Example: 0160 = 160 mm (6.3 in.), 1760 = 1760 mm (69.3 in.)
 (2) ArmorBlock Safety I/O

Table 28 - GuardShield Safety Light Curtain with Integrated Laser Alignment System

440L		P	4	K	L	0320	Y	D
a		b	c	d	e	f	g	h

a		b		c		d		e		f		g		h		
Code	Description	Code	Description	Code	Description	Code	Description	Code	Description	Code	Description	Code	Description	Code	Description	
440L	Bulletin number	P	Pair	4	Type 4 Category	J	14 mm (0.55 in.)	L	Integrated laser alignment system	0320	Code = mm ⁽¹⁾	Y	IP65 Environmental rating	A	5-pin M12 ⁽²⁾	
		T	Transmitter			K	30 mm (1.18 in.) Resolution			0480					D	Standard 5-pin M12 ⁽³⁾ Connector
		R	Receiver							0640						
		C	Cascading pair							0800						
		G	Cascade transmitter							0960						
		F	Cascade receiver Unit type							1120						
										1280						
										1440						
										1600						

(1) Example: 0320 = 320 mm (12.6 in.), 1600 = 1600 mm (62.99 in.)
 (2) ArmorBlock Safety I/O
 (3) XMTR 18-pin M12 receiver

Approximate Dimensions

Figure 30 - Standard and Cascaded GuardShield Safety Light Curtain [mm (in.)]

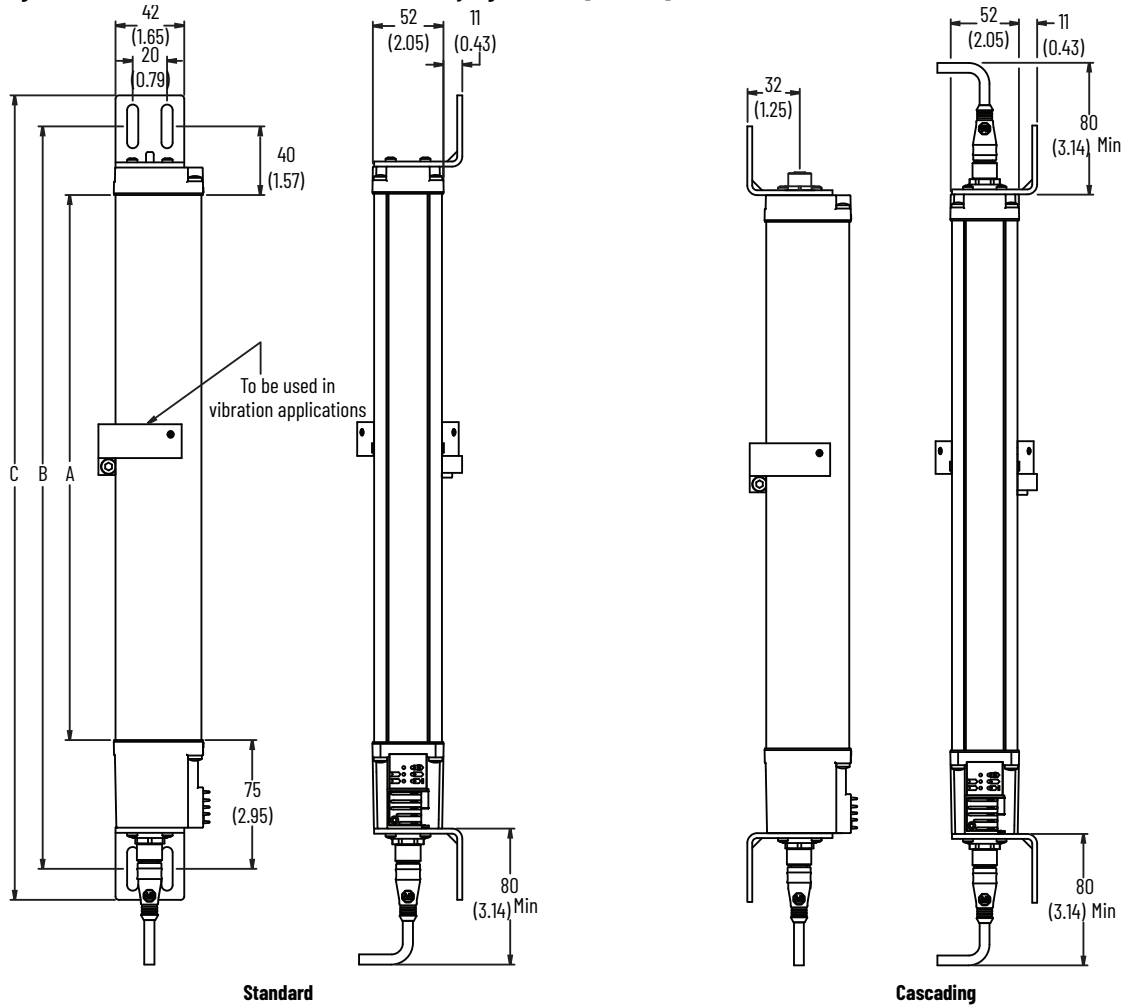

Cat. No. ⁽¹⁾	[A] Protective Height	[B] Mounting Value	[C] Total Length
440L-x4y0160Yz	160 ±0.5 (6.3) ±0.02	276 (10.9)	312 ±1.5 (12.3) ±0.06
440L-x4y0320Yz	320 ±0.5 (12.6) ±0.02	436 (17.2)	472 ±1.5 (18.6) ±0.06
440L-x4y0480Yz	480 ±0.5 (18.9) ±0.02	596 (28.5)	632 ±1.5 (24.9) ±0.06
440L-x4y0640Yz	640 ±0.5 (25.2) ±0.02	756 (29.8)	792 ±1.5 (31.2) ±0.06
440L-x4y0800Yz	800 ±0.6 (31.5) ±0.02	916 (36.1)	952 ±1.5 (37.5) ±0.06
440L-x4y0960Yz	960 ±0.6 (37.8) ±0.02	1076 (42.4)	1112 ±1.5 (43.8) ±0.06
440L-x4y1120Yz	1120 ±0.6 (44.1) ±0.02	1236 (48.7)	1272 ±1.8 (50.1) ±0.07
440L-x4y1280Yz	1280 ±0.7 (50.4) ±0.02	1396 (55.0)	1432 ±1.8 (56.4) ±0.07
440L-x4y1440Yz	1440 ±0.7 (56.7) ±0.03	1556 (61.3)	1592 ±1.8 (62.7) ±0.07
440L-x4y1600Yz	1600 ±0.8 (63.0) ±0.03	1716 (67.6)	1752 ±2.0 (69.0) ±0.08
440L-x4y1760Yz	1760 ±0.8 (69.3) ±0.03	1876 (73.9)	1912 ±2.0 (75.3) ±0.08

(1) x = J or K
y = C, F, G, P, R, or T
z = D or R

Figure 31 - Standard GuardShield Safety Light Curtain with Laser 440L-P4JL0320YD ^(a) [mm (in.)]

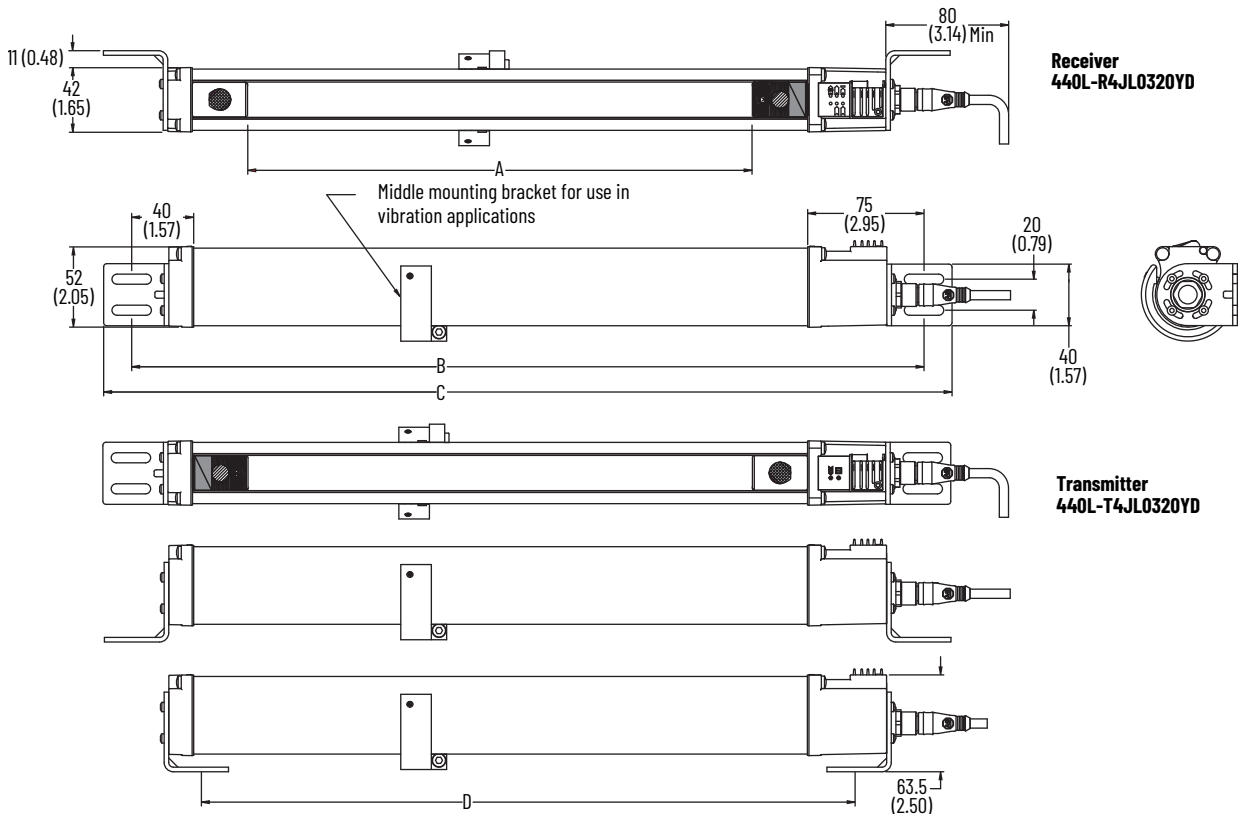

Cat. No. ⁽¹⁾	[A] Protective Height	[B] Mounting Value	[C] Total Length
440L-x4yL0320Yz	320 (12.6)	516 (20.3)	552 (21.7)
440L-x4yL0480Yz	480 (18.9)	686 (26.6)	712 (28.0)
440L-x4yL0640Yz	640 (25.2)	836 (32.9)	872 (34.3)
440L-x4yL0800Yz	800 (31.5)	996 (39.2)	103 (4.1)
440L-x4yL0960Yz	960 (37.8)	1156 (45.5)	119 (4.7)
440L-x4yL1120Yz	1120 (44.1)	1316 (51.8)	1352 (53.2)
440L-x4yL1280Yz	1280 (50.4)	1476 (58.1)	1512 (59.5)
440L-x4yL1440Yz	1440 (56.7)	1636 (64.4)	1672 (65.8)
440L-x4yL1600Yz	1600 (63)	1776 (69.9)	1832 (72.1)

(1) x = J or K
 y = C, F, G, P, R, or T
 z = A or D

(a) K = 30 mm resolution
 J = 14 mm resolution
 L = Laser

Figure 32 - Cascaded GuardShield Safety Light Curtain with Laser 440L-C4JL0320YD (a) [mm (in.)]

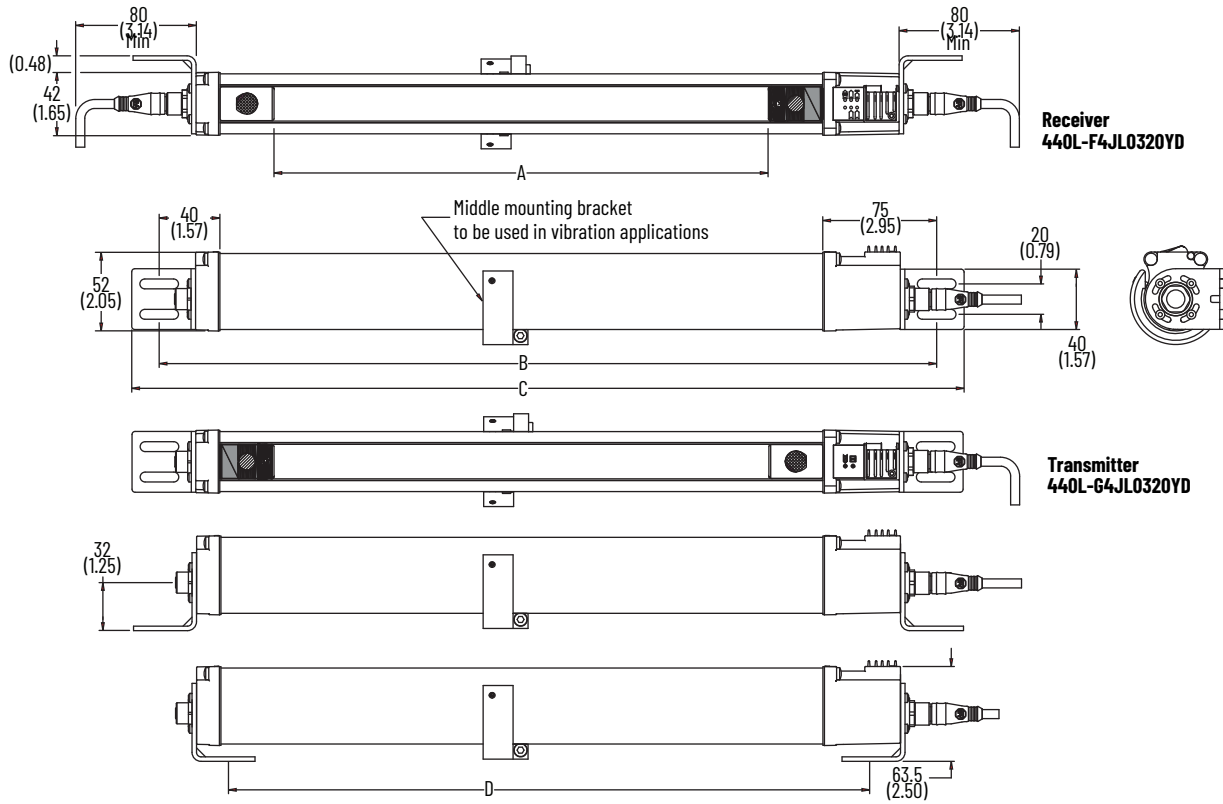

Remote Teach

The GuardShield Remote Teach safety light curtain system provides a remote means of changing a fixed blanking configuration (see [Teach-in Fixed Blanking on page 5](#)) within the GuardShield safety light curtain. This key selector switch box stops the need to open the GuardShield safety light curtain receiver door and perform the Teach function (see [Figure 33 on page 23](#)).

When a machine setup is changed, which requires a new fixed blanking field configuration, the GuardShield remote teach safety light curtain box is the ideal solution.

An IP65 metal key selector switch box is near the GuardShield safety light curtain receiver. The remote teach box mounts so the operator who performs the teach function has a clear view of the area being blanked out.

The GuardShield safety light curtain receiver requires a modified right angle mounting bracket to fit around the cable gland hardware on the receiver end cap (see [Figure 15 on page 12](#)). This bracket is supplied with each GuardShield remote teach safety light curtain receiver.

The GuardShield remote teach box safety light curtain system consists of:

- Remote teach key selector switch box with mounting plate and two keys
- GuardShield safety light curtain transmitter
- 2 m (6.56 ft) patchcord for connection between the 4-pin pigtail connector and the remote teach box
- GuardShield safety light curtain receiver with a 254 mm (10 in.) dual connector pigtail. The dual connector contains a 4-pin micro quick-disconnect and a standard 8-pin quick-disconnect GuardShield safety light curtain receiver.
- Modified mounting bracket for receiver bottom end cap

Figure 33 - GuardShield Remote Teach Safety Light Curtain Components

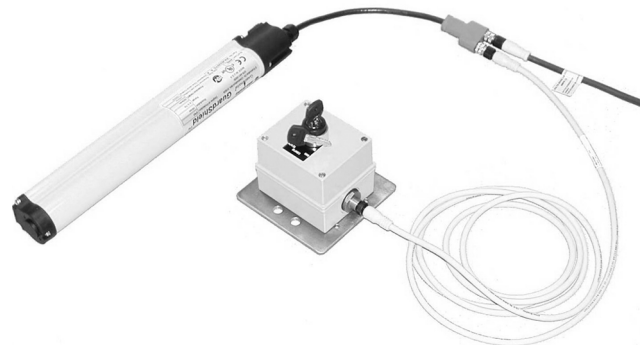

IMPORTANT The GuardShield remote teach safety light curtain box cannot be retrofitted. You can purchase the components separately (see [Table 30 on page 25](#)). If a GuardShield safety light curtain system is already purchased, the transmitter is a standard transmitter. The receiver part numbers vary by protective height (see [Table 31 on page 25](#)). See the [Table 29 on page 25](#) for a list of component parts of a remote teach system.

(a) K = 30 mm resolution
J = 14 mm resolution
L = Laser

System Delivery

The GuardShield remote teach safety light curtain system is delivered with the transmitter and receiver configured in the standard GuardShield safety light curtain Guard Only operating mode. This mode is Automatic Reset, and all features not activated.

Each GuardShield Remote Teach safety light curtain system comes with the 2 m (6.56 ft) Patchcord 889D-F4ACDM-2, Remote Teach Key Selector Switch Box 440L-M8600, and mounting hardware (see [Table 29 on page 25](#)), along with a standard GuardShield safety light curtain transmitter and remote teach receiver.

Remote Teach Box - Keyswitch Positions

The GuardShield remote teach safety light curtain box uses a Rockwell Automation 800FM series, three-position, IP66 rated, spring-loaded key selector switch. There are three key selector switch positions on the GuardShield remote teach safety light curtain box.

- **Run:** This key selector switch position is required for the GuardShield safety light curtain to operate in its normal operating mode.
- **Configure:** This key selector switch position simulates the opening of the GuardShield safety light curtain DIP switch door. This position sends a signal to the GuardShield safety light curtain firmware to change from the Run mode of operation to a Configuration mode of operation. In this mode, all outputs are in the off-state.
- **Teach:** This key selector switch position performs the function of changing the operating mode configuration of the GuardShield safety light curtain.

Figure 34 - Key Selector Switch Label Positions



System Installation

The GuardShield safety light curtain transmitter and receiver are properly mounted to the machinery to be guarded per [Installation and Mounting on page 9](#).

After you align the GuardShield safety light curtains and attain a green state, the safety light curtain is transmitting infrared light and the receiver OSSDs are high. You can now reconfigure the GuardShield safety light curtain.

Use the T8 torx bit supplied with each GuardShield safety light curtain bracket kit to open the GuardShield safety light curtain receiver door and set DIP switch 4 to the on position. This DIP switch allows the activation and configuration of a monitored fixed blanked area within the GuardShield safety light curtain protective height.

Make any additional DIP switch settings now.

IMPORTANT If EDM or reset functions are to be configured through DIP switch settings, confirm that the proper receiver wire connections are made.

It is not possible to blank out the sync beam, which is the first beam that is next to the GuardShield safety light curtain diagnostic status indicators.

If the transmitter configuration must change from the factory settings, set the DIP switches in the transmitter and follow the standard teach process.

Remote Teach Procedure

1. Position the object in the GuardShield safety light curtain sensing field, confirm that the synchronization beam is not obstructed.
2. Turn the key selector switch to the configure position. The red status indicator on the receiver flashes and the yellow blanking status indicator illuminates.
3. Turn and hold the key selector switch in the teach position
4. The GuardShield safety light curtain receiver yellow blanking status indicator begins to flash.
5. When the yellow blanking status indicator stops flashing, release the key selector switch to the configure position within 2 seconds.
6. The GuardShield safety light curtain receiver yellow blanking status indicator flashes three times to confirm that the new fixed blanking configuration is set.
7. Turn the key selector switch to the run position, the green status indicator on the GuardShield safety light curtain receiver illuminates.
8. Use the supplied test rod to confirm the fixed blanking area and any other settings are configured as expected.

You can configure and activate both fixed and one or two-beam floating blanking on the GuardShield safety light curtain.

IMPORTANT Once you change the factory DIP switch positions and perform the teach function (see [Teach-in Procedure Function on page 17](#)), the GuardShield safety light curtain is reconfigured. Any future teach procedure only changes the configuration of the fixed blanking area.

After teaching the GuardShield safety light curtain a new configuration, confirm that the expected configuration is present.

Fixed blanking creates a hole in the detection area of the GuardShield safety light curtain. Confirm that access to the hazard is restricted with barrier guarding. It must not be possible to access the hazard through the fixed blanked area.

Table 29 - Remote Teach System

Cat. No.	Description
440L-S4J0160YR	GuardShield Remote Teach safety light curtain system, 160 mm (6.3 in.) protective height 14 mm (0.55 in.) resolution
440L-S4J0320YR	GuardShield Remote Teach safety light curtain system, 320 mm (12.6 in.) protective height 14 mm (0.55 in.) resolution
440L-S4J0480YR	GuardShield Remote Teach safety light curtain system, 480 mm (18.9 in.) protective height 14 mm (0.55 in.) resolution
440L-S4J0640YR	GuardShield Remote Teach safety light curtain system, 640 mm (25.2 in.) protective height 14 mm (0.55 in.) resolution
440L-S4J0800YR	GuardShield Remote Teach safety light curtain system, 800 mm (31.5 in.) protective height 14 mm (0.55 in.) resolution
440L-S4J0960YR	GuardShield Remote Teach safety light curtain system, 960 mm (37.8 in.) protective height 14 mm (0.55 in.) resolution
440L-S4J1120YR	GuardShield Remote Teach safety light curtain system, 1120 mm (44.1 in.) protective height 14 mm (0.55 in.) resolution
440L-S4J1280YR	GuardShield Remote Teach safety light curtain system, 1280 mm (50.4 in.) protective height 14 mm (0.55 in.) resolution
440L-S4J1440YR	GuardShield Remote Teach safety light curtain system, 1440 mm (56.7 in.) protective height 14 mm (0.55 in.) resolution
440L-S4J1600YR	GuardShield Remote Teach safety light curtain system, 1600 mm (63 in.) protective height 14 mm (0.55 in.) resolution
440L-S4J1760YR	GuardShield Remote Teach safety light curtain system, 1760 mm (69.3 in.) protective height 14 mm (0.55 in.) resolution
440L-S4K0160YR	GuardShield Remote Teach safety light curtain system, 160 mm (6.3 in.) protective height 30 mm (1.18 in.) resolution
440L-S4K0320YR	GuardShield Remote Teach safety light curtain system, 320 mm (12.6 in.) protective height 30 mm (1.18 in.) resolution
440L-S4K0480YR	GuardShield Remote Teach safety light curtain system, 480 mm (18.9 in.) protective height 30 mm (1.18 in.) resolution
440L-S4K0640YR	GuardShield Remote Teach safety light curtain system, 640 mm (25.2 in.) protective height 30 mm (1.18 in.) resolution
440L-S4K0800YR	GuardShield Remote Teach safety light curtain system, 800 mm (31.5 in.) protective height 30 mm (1.18 in.) resolution
440L-S4K0960YR	GuardShield Remote Teach safety light curtain system, 960 mm (37.8 in.) protective height 30 mm (1.18 in.) resolution
440L-S4K1120YR	GuardShield Remote Teach safety light curtain system, 1120 mm (44.1 in.) protective height 30 mm (1.18 in.) resolution
440L-S4K1280YR	GuardShield Remote Teach safety light curtain system, 1280 mm (50.4 in.) protective height 30 mm (1.18 in.) resolution
440L-S4K1440YR	GuardShield Remote Teach safety light curtain system, 1440 mm (56.7 in.) protective height 30 mm (1.18 in.) resolution
440L-S4K1600YR	GuardShield Remote Teach safety light curtain system, 1600 mm (63 in.) protective height 30 mm (1.18 in.) resolution
440L-S4K1760YR	GuardShield Remote Teach safety light curtain system, 1760 mm (69.3 in.) protective height 30 mm (1.18 in.) resolution

Table 30 - Remote Teach System Component Parts

Cat. No.	Description
800F-AKR3825	Replacement key
440L-M8600	Remote teach box
889D-F4ACDM-2	2 m (6.56 ft) patchcord

Table 31 - Remote Teach Receiver

Cat. No.	Description
440L-R4J0160YR	Receiver, GuardShield Remote Teach safety light curtain, 160 mm (6.3 in.) protective height, 14 mm (0.55 in.) resolution
440L-R4J0320YR	Receiver, GuardShield Remote Teach safety light curtain, 320 mm (12.6 in.) protective height, 14 mm (0.55 in.) resolution
440L-R4J0480YR	Receiver, GuardShield Remote Teach safety light curtain, 480 mm (18.9 in.) protective height, 14 mm (0.55 in.) resolution
440L-R4J0640YR	Receiver, GuardShield Remote Teach safety light curtain, 640 mm (25.2 in.) protective height, 14 mm (0.55 in.) resolution
440L-R4J0800YR	Receiver, GuardShield Remote Teach safety light curtain, 800 mm (31.5 in.) protective height, 14 mm (0.55 in.) resolution
440L-R4J0960YR	Receiver, GuardShield Remote Teach safety light curtain, 960 mm (37.8 in.) protective height, 14 mm (0.55 in.) resolution
440L-R4J1120YR	Receiver, GuardShield Remote Teach safety light curtain, 1120 mm (44.1 in.) protective height, 14 mm (0.55 in.) resolution
440L-R4J1280YR	Receiver, GuardShield Remote Teach safety light curtain, 1280 mm (50.4 in.) protective height, 14 mm (0.55 in.) resolution
440L-R4J1440YR	Receiver, GuardShield Remote Teach safety light curtain, 1440 mm (56.7 in.) protective height, 14 mm (0.55 in.) resolution
440L-R4J1600YR	Receiver, GuardShield Remote Teach safety light curtain, 1600 mm (63 in.) protective height, 14 mm (0.55 in.) resolution
440L-R4J1760YR	Receiver, GuardShield Remote Teach safety light curtain, 1760 mm (69.3 in.) protective height, 14 mm (0.55 in.) resolution
440L-R4K0160YR	Receiver, GuardShield Remote Teach safety light curtain, 160 mm (6.3 in.) protective height, 30 mm resolution
440L-R4K0320YR	Receiver, GuardShield Remote Teach safety light curtain, 320 mm (12.6 in.) protective height, 30 mm resolution
440L-R4K0480YR	Receiver, GuardShield Remote Teach safety light curtain, 480 mm (18.9 in.) protective height, 30 mm resolution
440L-R4K0640YR	Receiver, GuardShield Remote Teach safety light curtain, 640 mm (25.2 in.) protective height, 30 mm resolution
440L-R4K0800YR	Receiver, GuardShield Remote Teach safety light curtain, 800 mm (31.5 in.) protective height, 30 mm resolution
440L-R4K0960YR	Receiver, GuardShield Remote Teach safety light curtain, 960 mm (37.8 in.) protective height, 30 mm resolution
440L-R4K1120YR	Receiver, GuardShield Remote Teach safety light curtain, 1120 mm (44.1 in.) protective height, 30 mm resolution
440L-R4K1280YR	Receiver, GuardShield Remote Teach safety light curtain, 1280 mm (50.4 in.) protective height, 30 mm resolution
440L-R4K1440YR	Receiver, GuardShield Remote Teach safety light curtain, 1440 mm (56.7 in.) protective height, 30 mm resolution
440L-R4K1600YR	Receiver, GuardShield Remote Teach safety light curtain, 1600 mm (63.0 in.) protective height, 30 mm resolution
440L-R4K1760YR	Receiver, GuardShield Remote Teach safety light curtain, 1760 mm (69.3 in.) protective height, 30 mm resolution

Figure 35 - Remote Teach Box Dimensions [mm (in.)]

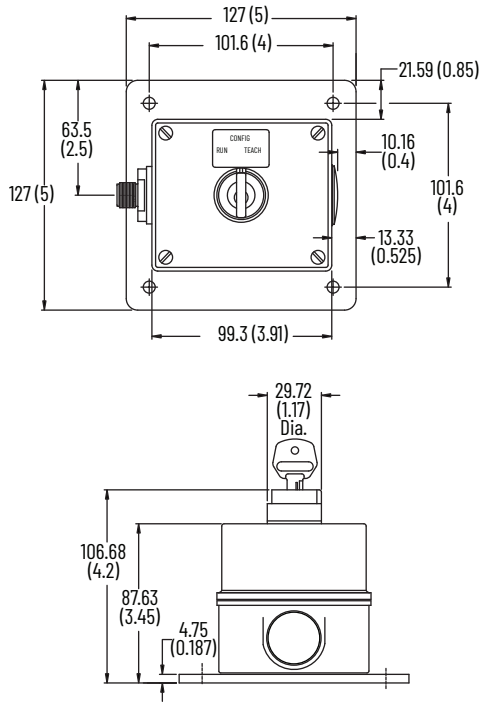

Corner Mirror for Multi-sided Guarding

Figure 36 - Mirror 440L-AM075 Dimensions

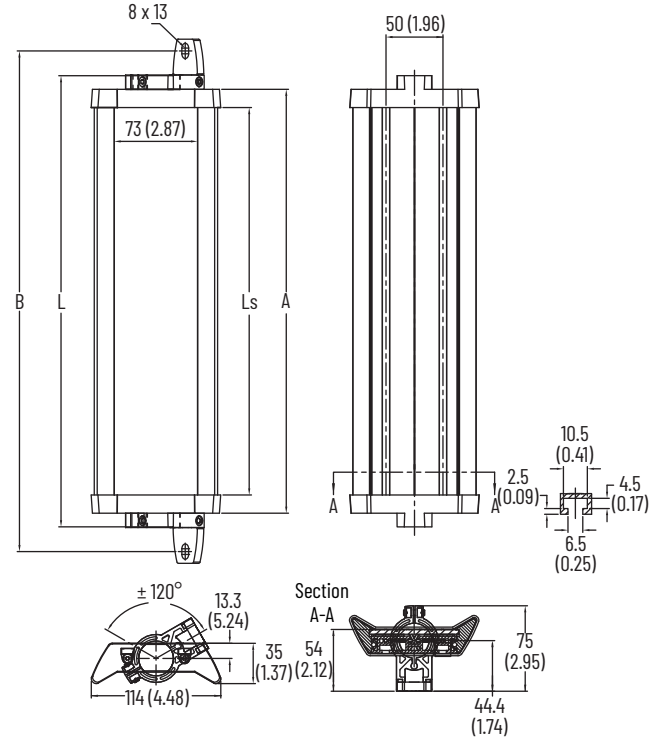

Table 32 - Mirror 440L-AM075 Catalog Number

Cat No.	Series	Description	L	L _S	A	B
440L-AM0750300	A	Mirror, 300 mm (11.81 in.), 15 m (49.21 ft)	396	340	372	440
440L-AM0750450	A	Mirror, 450 mm (17.72 in.), 15 m (49.21 ft)	546	490	522	590
440L-AM0750600	A	Mirror, 600 mm (23.62 in.), 15 m (49.21 ft)	696	640	672	740
440L-AM0750750	A	Mirror, 750 mm (29.53 in.), 15 m (49.21 ft)	846	790	822	890
440L-AM0750900	A	Mirror, 900 mm (35.43 in.), 15 m (49.21 ft)	996	940	972	1040
440L-AM0751050	A	Mirror, 1050 mm (41.34 in.), 15 m (49.21 ft)	1146	1090	1122	1190
440L-AM0751200	A	Mirror, 1200 mm (47.24 in.), 15 m (49.21 ft)	1296	1240	1272	1340
440L-AM0751350	A	Mirror, 1350 mm (53.15 in.), 15 m (49.21 ft)	1446	1390	1422	1490
440L-AM0751500	A	Mirror, 1500 mm (59.05 in.), 15 m (49.21 ft)	1596	1540	1572	1640
440L-AM0751650	A	Mirror, 1650 mm (64.96 in.), 15 m (49.21 ft)	1746	1690	1722	1790
440L-AM0751800	A	Mirror, 1800 mm (70.86 in.), 15 m (49.21 ft)	1896	1840	1872	1940

IMPORTANT Each mirror reduces the maximum scan range by 10% per mirror. Each corner mirror is supplied with two end-cap mounting brackets.

Figure 37 - Mirror 440L-AM125 Dimensions

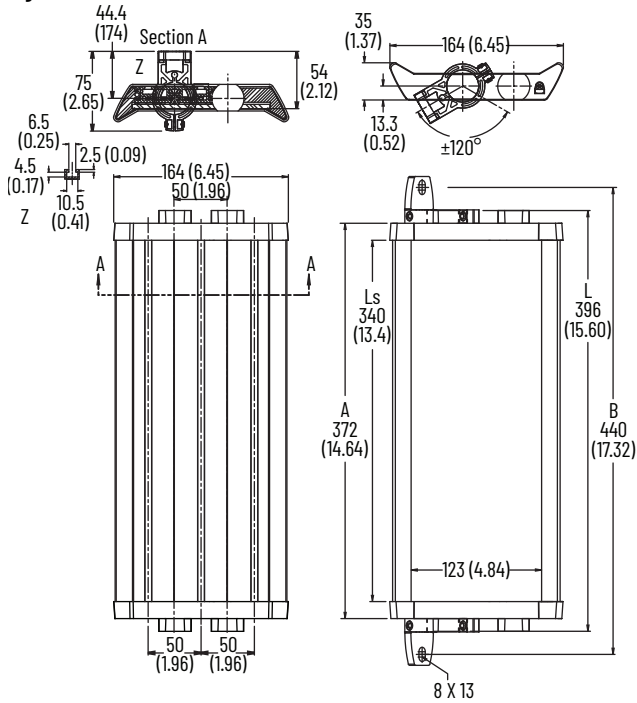



Table 33 - Mirror 440L-AM125 Catalog Numbers

Cat No.	Series	Description	L	L _S	A	B
440L-AM1250300	A	Mirror, 300 mm (11.81 in.), 15 m (49.21 ft)	396	340	372	440
440L-AM1250450	A	Mirror, 450 mm (17.72 in.), 15 m (49.21 ft)	546	490	522	590
440L-AM1250600	A	Mirror, 600 mm (23.62 in.), 15 m (49.21 ft)	696	640	672	740
440L-AM1250750	A	Mirror, 750 mm (29.53 in.), 15 m (49.21 ft)	846	790	822	890
440L-AM1250900	A	Mirror, 900 mm (35.43 in.), 15 m (49.21 ft)	996	940	972	1040
440L-AM1251050	A	Mirror, 1050 mm (41.34 in.), 15 m (49.21 ft)	1146	1090	1122	1190
440L-AM1251200	A	Mirror, 1200 mm (47.24 in.), 15 m (49.21 ft)	1296	1240	1272	1340
440L-AM1251350	A	Mirror, 1350 mm (53.15 in.), 15 m (49.21 ft)	1446	1390	1422	1490
440L-AM1251500	A	Mirror, 1500 mm (59.05 in.), 15 m (49.21 ft)	1596	1540	1572	1640
440L-AM1251650	A	Mirror, 1650 mm (64.96 in.), 15 m (49.21 ft)	1746	1690	1722	1790
440L-AM1251800	A	Mirror, 1800 mm (70.86 in.), 15 m (49.21 ft)	1896	1840	1872	1940

Table 34 - Corner Mirror for Multi-sided Guarding ⁽¹⁾

GuardShield Safety Light Curtain Cat. No. ⁽²⁾	Narrow Mirror Short-Range 0...4 m (0...13.12 ft)	Cat. No. ⁽³⁾	Wide Mirror Long-Range 4...15 m (13.12...49.21 ft)	Cat. No. ⁽³⁾
440L-P4y0160Yz 440L-P2Ky0160YD		440L-AM0750300		440L-AM1250300
440L-P4y0320Yz 440L-P2Ky0320YD		440L-AM0750450		440L-AM1250450
440L-P4y0480Yz 440L-P2Ky0480YD 440L-P4A2500YD		440L-AM0750600		440L-AM1250600
440L-P4y0640Yz 440L-P2Ky0640YD		440L-AM0750750		440L-AM1250750
440L-P4y0800Yz 440L-P2Ky0800YD		440L-AM0750900		440L-AM1250900
440L-P4y0960Yz 440L-P2Ky0960YD 440L-P4A3400YD		440L-AM0751050		440L-AM1251050
440L-P4y1120Yz 440L-P2Ky1120YD		440L-AM0751200		440L-AM1251200
440L-P4y1280Yz 440L-P2Ky1280YD		440L-AM0751350		440L-AM1251350
440L-P4y1440Yz 440L-P2Ky1440YD		440L-AM0751500		440L-AM1251500
440L-P4y1600Yz 440L-P2Ky1600YD		440L-AM0751650		440L-AM1251650
440L-P4y1760Yz 440L-P2Ky1760YD		440L-AM0751800		440L-AM1251800

- (1) Specially constructed glass mirrors for two and three-sided safeguard applications.
- (2) y = D or R
z = A or D
- (3) One kit (two brackets) is shipped with each mirror.

Figure 38 - Swivel Mount Bracket 442L-AF6106 [mm (in.)]

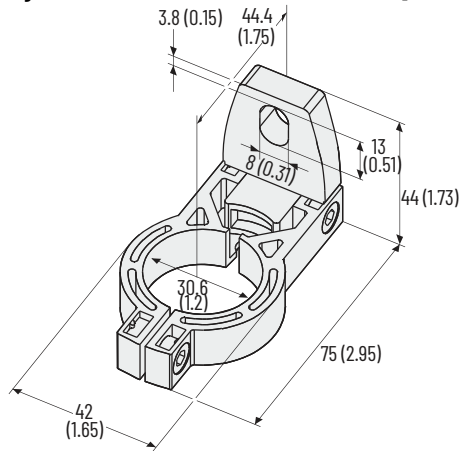
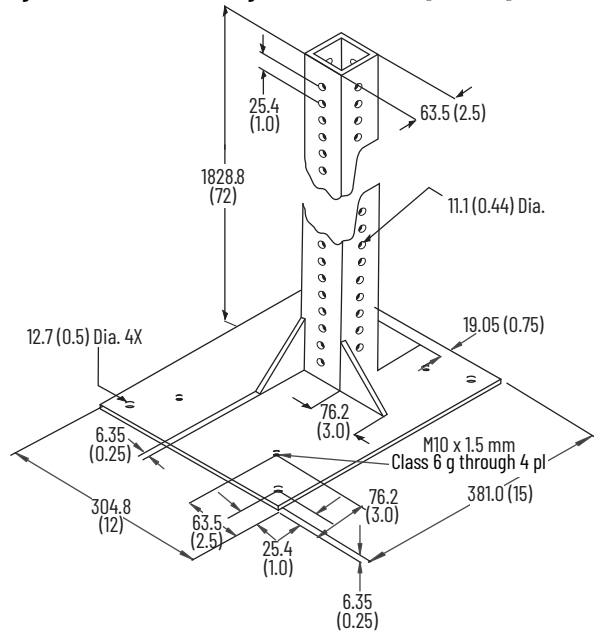

Figure 39 - Pedestal Mounting Stand 440L-AMSTD [mm (in.)]



Laser Alignment Tool

Figure 40 - Laser Alignment Tool 440L-ALAT [mm (in.)]

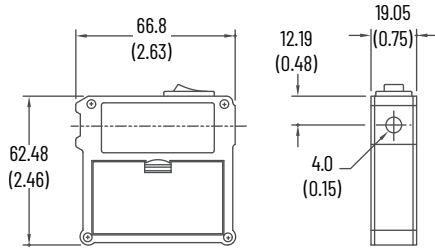

Figure 41 - Laser Alignment Tool Clamp 450L-ALAT-C



Weld Shields

The weld shields of the GuardShield safety light curtain are sold as pairs in the same lengths as the protective heights of the GuardShield safety light curtain. For detailed information, see publication [440L-IN009](#).

These polycarbonate weld shields are disposable devices to help protect the front window of the GuardShield safety light curtain from damage.

Figure 42 - GS Weld Shield Dimensions [mm (in.)]

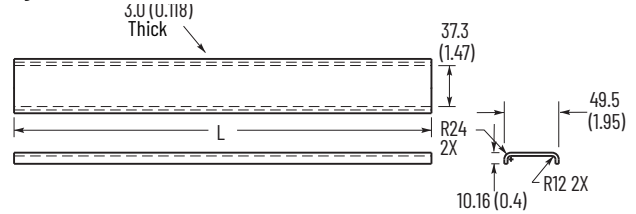

Cat. No.	Dimension L [mm (in.)]
440L-AGWS0160	175.3 (6.9)
440L-AGWS0320	335.3 (13.20)
440L-AGWS0480	495.3 (19.50)
440L-AGWS0640	655.3 (25.80)
440L-AGWS0800	815.3 (32.10)
440L-AGWS0960	975.4 (38.40)
440L-AGWS1120	1135.4 (44.70)
440L-AGWS1280	1295.4 (51.00)
440L-AGWS1440	1455.4 (57.30)
440L-AGWS1600	1615.4 (63.60)
440L-AGWS1760	1778 (70.00)

Optional Accessories

Table 35 - Accessories













Description	Cat. No.
 Steel L-shaped end cap mounting bracket (four per package) ⁽¹⁾	440L-AF6101
 Aluminum middle mounting bracket for vibratory applications ⁽²⁾	440L-AF6108
 Power supply Output - 24V DC, 3 A, 72 W	1606-XLP72E
 Laser alignment tool	440L-ALAT
 GuardShield safety light curtain laser alignment tool bracket	450L-ALAT-C
 Mounting stand	440L-AMSTD
 Vertical shock mount kit ⁽¹⁾	440L-AF6120
 Horizontal shock mount kit ⁽¹⁾	440L-AF6121
 Middle vertical mount kit ⁽¹⁾	440L-AF6122
 Middle horizontal mount kit ⁽¹⁾	440L-AF6123
 GuardShield safety light curtain weld shield pair ⁽³⁾	440L-AGWS0160
	440L-AGWS0320
	440L-AGWS0480
	440L-AGWS0640
	440L-AGWS0800
	440L-AGWS0960
	440L-AGWS1120
	440L-AGWS1280
	440L-AGWS1440
440L-AGWS1600	
440L-AGWS1760	
GuardShield light curtain Test Rod 14 mm (0.55 in.)	450L-AT-14
GuardShield light curtain Test Rod 30 mm (1.18 in.)	450L-AT-30
GuardShield light curtain Test Rod 40 mm (1.57 in.)	450L-AT-40

Table 35 - Accessories (Continued)

Description	Cat. No.	
 GuardShield light curtain washdown enclosure kit ⁽⁴⁾	440L-AGST320	
	440L-AGST480	
	440L-AGST640	
	440L-AGST800	
 M12 Receiver Termination Plug	8-pin for standard cascading GuardShield safety light curtain receiver (if used as a standalone pair or if the last segment pair in a cascading system).	898D-81CU-DM
	5-pin for cascading GuardShield safety light curtain with ArmorBlock Guard I/O module connectivity (required on the top connector of the receiver if the cascading pair is used as a standalone system or as the last segment pair in the cascading system).	898D-418U-DM

- (1) Four brackets supplied with each GuardShield safety light curtain pair.
- (2) See publication [440L-IN010](#).
- (3) See publication [440L-IN009](#).
- (4) Can be used on Standard GuardShield light curtain POC and PAC. See publication [440L-IN014](#).

Technical Specifications

Attribute	Description				
Light beams	8...176				
Protective field	<ul style="list-style-type: none"> 160...1760 mm (6.3...69.29 in.) in 160 mm (6.3 in.) increments for Standard GuardShield safety light curtain 320...1600 mm for GuardShield safety light curtain with integrated laser alignment 				
Resolution	14 mm (0.55 in.), 30 mm (1.18 in.)				
Range	<ul style="list-style-type: none"> 14 mm (0.55 in.) 0.3...7.0 m (0.98...22.9 ft), 30 mm (1.18 in.) 0.3...16.0 m (0.98...52.5 ft) 				
Response time	OSSD - On to off: (Reaction times) <ul style="list-style-type: none"> 20...25 ms uncoded 30...35 ms coded 				
Power supply	24V DC \pm 20% Power supply must meet the requirements of IEC 60204-1 and IEC 61496-1.				
Power consumption	400 mA max (unloaded)				
IR transmitter	Infrared status indicator (wave length 870 nm)				
Aperture angle	Within \pm 2.5° for transmitter and receiver				
Operating condition	IR transmitter On				
Functions	<ul style="list-style-type: none"> Guard Only: On/Off operation with clear/obstructed detection area Start Interlock: Interlock at startup - Reset by actuation of momentary N.O. push-button switch (or interruption/restoration of safety light curtain) Restart Interlock: Interlock at interruption of sensing field - Reset by actuation of momentary N.O. push-button switch Relay Monitoring: Monitoring a switch contact of the installation Coding: Can be necessary for multiplex alignment Test Function: Triggering of system test via external switch 				
Inputs transmitter	<table border="1"> <tr> <td>Machine Test Signal</td> <td> Minimum duration 100 ms Voltage level for Logic 0: 0...5V DC Voltage level for Logic Hi 1: > 16V DC </td> </tr> </table>	Machine Test Signal	Minimum duration 100 ms Voltage level for Logic 0: 0...5V DC Voltage level for Logic Hi 1: > 16V DC		
Machine Test Signal	Minimum duration 100 ms Voltage level for Logic 0: 0...5V DC Voltage level for Logic Hi 1: > 16V DC				
Inputs receiver	<table border="1"> <tr> <td>Start/Restart Interlock</td> <td> Logic Lo Minimum duration 100 ms Maximum duration 900 ms Voltage level for Logic Lo 0: 0...5V DC Voltage level for Logic Hi 1: > 16V DC </td> </tr> <tr> <td>MPCE (EDM)</td> <td> 300 ms after activation of OSSD <ul style="list-style-type: none"> Voltage level for Logic 0: 0...5V DC Voltage level for Logic Hi 1: > 16V DC </td> </tr> </table>	Start/Restart Interlock	Logic Lo Minimum duration 100 ms Maximum duration 900 ms Voltage level for Logic Lo 0: 0...5V DC Voltage level for Logic Hi 1: > 16V DC	MPCE (EDM)	300 ms after activation of OSSD <ul style="list-style-type: none"> Voltage level for Logic 0: 0...5V DC Voltage level for Logic Hi 1: > 16V DC
Start/Restart Interlock	Logic Lo Minimum duration 100 ms Maximum duration 900 ms Voltage level for Logic Lo 0: 0...5V DC Voltage level for Logic Hi 1: > 16V DC				
MPCE (EDM)	300 ms after activation of OSSD <ul style="list-style-type: none"> Voltage level for Logic 0: 0...5V DC Voltage level for Logic Hi 1: > 16V DC 				
Outputs	<ul style="list-style-type: none"> Safety Outputs (OSSDs): 2 solid-state outputs, max switching capacity 500 mA, short circuit protected, max residual voltage 2V (excl. voltage drop through cables) Auxiliary Output: Solid-state output, max power consumption 500 mA, max residual voltage 2V - non-safety output 				
Status indicators receiver	<ul style="list-style-type: none"> OSSD on-state: Constant on when OSSD is in on-state (green indicator) OSSD off-state: Constant on when OSSD is in off-state (red indicator) <ul style="list-style-type: none"> Lights up at interruption of protective field or if fault occurs Blanking: Constant on when Fixed Blanking is active <ul style="list-style-type: none"> Flashes, if Floating Blanking is active alone or together with Fixed Blanking (yellow indicator) Alignment: Lights up, if input signal is too weak (amber indicator) Interlock: Lights up when safety light curtain is in Start or Restart Interlock mode (yellow indicator) 				
Status indicators transmitter	<ul style="list-style-type: none"> Power on: Lights up, when voltage is on (amber indicator) Emitting: Constant on when transmitter is active (yellow indicator) 				
QD connectors	<ul style="list-style-type: none"> Transmitter: M12 plug 4 pin Receiver: M12 plug 8 pin Standard GuardShield safety light curtain and GuardShield safety light curtain with ArmorBlock I/O: 5-pin M12 for transmitter and receiver 				
Cable length	Maximum 30 m (100 ft)				
Ambient temperature	<ul style="list-style-type: none"> During operation: -10...+55 °C (14...131 °F) For storage: -25...+75 °C (-13...+167 °F) 				
Humidity of the air	Up to 95% (without condensation) 20...55 °C (68...131 °F)				
Enclosure rating	IP65				
Vibration resistance	Per IEC 61496-1, IEC 60068-2-6 Frequency 10...55 Hz Amplitude 0.35 mm (0.1 in.)				
Shock	Per IEC 61496-1, IEC 60068-2-29 Acceleration 10 g, Duration 16 ms				
Material	<ul style="list-style-type: none"> Housing: Aluminum Cover: PMMA (acrylic) 				
Dimensions (cross section)	Approx. 40 x 50 mm (1.57 x 1.96 in.). See Figure 31 on page 22 .				
Accessories included	Test rod, mounting brackets, operating instructions, security tool to perform teach-in procedure				
Approvals	IEC 61496 Parts 1 and 2, UL 61496 Parts 1 and 2, UL 1998				
Safety classification	Type 4 per EN/IEC 61496, Category 4 EN/ISO 13849, SIL 3, IEC 61508, SIL CL 3, EN 62061, PL e, EN/ISO 13849				
PFH (mean probability of a dangerous failure/hr)	<ul style="list-style-type: none"> Standalone sys.: 9.51×10^{-9} Cascading sys. (host/guest): 1.95×10^{-8} Cascading sys. (host/guest/guest): 2.75×10^{-8} 				
T _M (mission time)	20 years (EN ISO 13849)				
Transmitter wave length	870 nm				

Table 36 - Resolution - Standard GuardShield Safety Light Curtain

Sensor Pair	Transmitter	Receiver	Resolution [mm (in.)]	No. of Beams	Protective Heights [mm (in.)]	Pair Weight [kg (lb)]
Finger Resolution						
440L-P4J0160YD	440L-T4J0160YD	440L-R4J0160YD	14 (0.55)	16	160 (6.3)	3.15 (1.43)
440L-P4J0320YD	440L-T4J0320YD	440L-R4J0320YD	14 (0.55)	32	320 (12.59)	5.17 (2.35)
440L-P4J0480YD	440L-T4J0480YD	440L-R4J0480YD	14 (0.55)	48	480 (18.89)	6.59 (2.99)
440L-P4J0640YD	440L-T4J0640YD	440L-R4J0640YD	14 (0.55)	64	640 (25.19)	7.99 (3.62)
440L-P4J0800YD	440L-T4J0800YD	440L-R4J0800YD	14 (0.55)	80	800 (31.49)	9.43 (4.28)
440L-P4J0960YD	440L-T4J0960YD	440L-R4J0960YD	14 (0.55)	96	960 (37.79)	12.21 (5.54)
440L-P4J1120YD	440L-T4J1120YD	440L-R4J1120YD	14 (0.55)	112	1120 (44.09)	13.44 (6.10)
440L-P4J1280YD	440L-T4J1280YD	440L-R4J1280YD	14 (0.55)	128	1280 (50.39)	14.88 (6.75)
440L-P4J1440YD	440L-T4J1440YD	440L-R4J1440YD	14 (0.55)	144	1440 (56.69)	16.32 (7.40)
440L-P4J1600YD	440L-T4J1600YD	440L-R4J1600YD	14 (0.55)	160	1600 (62.99)	17.76 (8.06)
440L-P4J1760YD	440L-T4J1760YD	440L-R4J1760YD	14 (0.55)	176	1760 (69.29)	19.20 (8.71)
Hand Resolution						
440L-P4K0160YD	440L-T4K0160YD	440L-R4K0160YD	30 (1.18)	8	160 (6.3)	3.54 (1.61)
440L-P4K0320YD	440L-T4K0320YD	440L-R4K0320YD	30 (1.18)	16	320 (12.59)	5.33 (2.42)
440L-P4K0480YD	440L-T4K0480YD	440L-R4K0480YD	30 (1.18)	24	480 (18.89)	6.88 (3.12)
440L-P4K0640YD	440L-T4K0640YD	440L-R4K0640YD	30 (1.18)	32	640 (25.19)	8.25 (3.74)
440L-P4K0800YD	440L-T4K0800YD	440L-R4K0800YD	30 (1.18)	40	800 (31.49)	9.63 (4.37)
440L-P4K0960YD	440L-T4K0960YD	440L-R4K0960YD	30 (1.18)	48	960 (37.79)	12.45 (5.65)
440L-P4K1120YD	440L-T4K1120YD	440L-R4K1120YD	30 (1.18)	56	1120 (44.09)	13.73 (6.23)
440L-P4K1280YD	440L-T4K1280YD	440L-R4K1280YD	30 (1.18)	64	1280 (50.39)	16.40 (7.44)
440L-P4K1440YD	440L-T4K1440YD	440L-R4K1440YD	30 (1.18)	72	1440 (56.69)	17.84 (8.10)
440L-P4K1600YD	440L-T4K1600YD	440L-R4K1600YD	30 (1.18)	80	1600 (62.99)	19.28 (8.75)
440L-P4K1760YD	440L-T4K1760YD	440L-R4K1760YD	30 (1.18)	88	1760 (69.29)	20.72 (9.40)

Table 37 - Resolution - Standard GuardShield Safety Light Curtain with Integrated Laser Alignment System

Sensor Pair	Transmitter	Receiver	Resolution [mm (in.)]	No. of Beams	Protective Heights [mm (in.)]	Pair Weight [kg (lb)]
Finger Resolution						
440L-P4JL0320YD	440L-T4JL0320YD	440L-R4JL0320YD	14 (0.55)	32	320 (12.59)	5.17 (2.35)
440L-P4JL0480YD	440L-T4JL0480YD	440L-R4JL0480YD	14 (0.55)	48	480 (18.89)	6.59 (2.99)
440L-P4JL0640YD	440L-T4JL0640YD	440L-R4JL0640YD	14 (0.55)	64	640 (25.19)	7.99 (3.62)
440L-P4JL0800YD	440L-T4JL0800YD	440L-R4JL0800YD	14 (0.55)	80	800 (31.49)	9.43 (4.28)
440L-P4JL0960YD	440L-T4JL0960YD	440L-R4JL0960YD	14 (0.55)	96	960 (37.79)	12.21 (5.54)
440L-P4JL1120YD	440L-T4JL1120YD	440L-R4JL1120YD	14 (0.55)	112	1120 (44.09)	13.44 (6.10)
440L-P4JL1280YD	440L-T4JL1280YD	440L-R4JL1280YD	14 (0.55)	128	1280 (50.39)	14.88 (6.75)
440L-P4JL1440YD	440L-T4JL1440YD	440L-R4JL1440YD	14 (0.55)	144	1440 (56.69)	16.32 (7.40)
440L-P4JL1600YD	440L-T4JL1600YD	440L-R4JL1600YD	14 (0.55)	160	1600 (62.99)	17.76 (8.06)
Hand Resolution						
440L-P4KL0320YD	440L-T4KL0320YD	440L-R4KL0320YD	30 (1.18)	16	320 (12.59)	5.33 (2.42)
440L-P4KL0480YD	440L-T4KL0480YD	440L-R4KL0480YD	30 (1.18)	24	480 (18.89)	6.88 (3.12)
440L-P4KL0640YD	440L-T4KL0640YD	440L-R4KL0640YD	30 (1.18)	32	640 (25.19)	8.25 (3.74)
440L-P4KL0800YD	440L-T4KL0800YD	440L-R4KL0800YD	30 (1.18)	40	800 (31.49)	9.63 (4.37)
440L-P4KL0960YD	440L-T4KL0960YD	440L-R4KL0960YD	30 (1.18)	48	960 (37.79)	12.45 (5.65)
440L-P4KL1120YD	440L-T4KL1120YD	440L-R4KL1120YD	30 (1.18)	56	1120 (44.09)	13.73 (6.23)
440L-P4KL1280YD	440L-T4KL1280YD	440L-R4KL1280YD	30 (1.18)	64	1280 (50.39)	16.40 (7.44)
440L-P4KL1440YD	440L-T4KL1440YD	440L-R4KL1440YD	30 (1.18)	72	1440 (56.69)	17.84 (8.10)
440L-P4KL1600YD	440L-T4KL1600YD	440L-R4KL1600YD	30 (1.18)	80	1600 (62.99)	19.28 (8.75)

Table 38 - Resolution - Standard GuardShield Safety Light Curtain with Integrated Laser Alignment and ArmorBlock I/O Connection

Sensor Pair	Transmitter	Receiver	Resolution [mm (in.)]	No. of Beams	Protective Heights [mm (in.)]	Pair Weight [kg (lb)]
Finger Resolution						
440L-P4JL0320YA	440L-T4JL0320YA	440L-R4JL0320YA	14 (0.55)	32	320 (12.59)	5.17 (2.35)
440L-P4JL0480YA	440L-T4JL0480YA	440L-R4JL0480YA	14 (0.55)	48	480 (18.89)	6.59 (2.99)
440L-P4JL0640YA	440L-T4JL0640YA	440L-R4JL0640YA	14 (0.55)	64	640 (25.19)	7.99 (3.62)
440L-P4JL0800YA	440L-T4JL0800YA	440L-R4JL0800YA	14 (0.55)	80	800 (31.49)	9.43 (4.28)
440L-P4JL0960YA	440L-T4JL0960YA	440L-R4JL0960YA	14 (0.55)	96	960 (37.79)	12.21 (5.54)
440L-P4JL1120YA	440L-T4JL1120YA	440L-R4JL1120YA	14 (0.55)	112	1120 (44.09)	13.44 (6.10)
440L-P4JL1280YA	440L-T4JL1280YA	440L-R4JL1280YA	14 (0.55)	128	1280 (50.39)	14.88 (6.75)
440L-P4JL1440YA	440L-T4JL1440YA	440L-R4JL1440YA	14 (0.55)	144	1440 (56.69)	16.32 (7.40)
440L-P4JL1600YA	440L-T4JL1600YA	440L-R4JL1600YA	14 (0.55)	160	1600 (62.99)	17.76 (8.06)
Hand Resolution						
440L-P4KL0320YA	440L-T4KL0320YA	440L-R4KL0320YA	30 (1.18)	16	320 (12.59)	5.33 (2.42)
440L-P4KL0480YA	440L-T4KL0480YA	440L-R4KL0480YA	30 (1.18)	24	480 (18.89)	6.88 (3.12)
440L-P4KL0640YA	440L-T4KL0640YA	440L-R4KL0640YA	30 (1.18)	32	640 (25.19)	8.25 (3.74)
440L-P4KL0800YA	440L-T4KL0800YA	440L-R4KL0800YA	30 (1.18)	40	800 (31.49)	9.63 (4.37)
440L-P4KL0960YA	440L-T4KL0960YA	440L-R4KL0960YA	30 (1.18)	48	960 (37.79)	12.45 (5.65)
440L-P4KL1120YA	440L-T4KL1120YA	440L-R4KL1120YA	30 (1.18)	56	1120 (44.09)	13.73 (6.23)
440L-P4KL1280YA	440L-T4KL1280YA	440L-R4KL1280YA	30 (1.18)	64	1280 (50.39)	16.40 (7.44)
440L-P4KL1440YA	440L-T4KL1440YA	440L-R4KL1440YA	30 (1.18)	72	1440 (56.69)	17.84 (8.10)
440L-P4KL1600YA	440L-T4KL1600YA	440L-R4KL1600YA	30 (1.18)	80	1600 (62.99)	19.28 (8.75)

Table 39 - Resolution - Cascading GuardShield Safety Light Curtain

Sensor Pair	Transmitter	Receiver	Resolution [mm (in.)]	No. of Beams	Protective Heights [mm (in.)]	Pair Weight [kg (lb)]
Finger Resolution						
440L-C4J0320YD	440L-G4J0320YD	440L-F4J0320YD	14 (0.55)	32	320 (12.59)	5.17 (2.35)
440L-C4J0480YD	440L-G4J0480YD	440L-F4J0480YD	14 (0.55)	48	480 (18.89)	6.59 (2.99)
440L-C4J0640YD	440L-G4J0640YD	440L-F4J0640YD	14 (0.55)	64	640 (25.19)	7.99 (3.62)
440L-C4J0800YD	440L-G4J0800YD	440L-F4J0800YD	14 (0.55)	80	800 (31.49)	9.43 (4.28)
440L-C4J0960YD	440L-G4J0960YD	440L-F4J0960YD	14 (0.55)	96	960 (37.79)	12.21 (5.54)
440L-C4J1120YD	440L-G4J1120YD	440L-F4J1120YD	14 (0.55)	112	1120 (44.09)	13.44 (6.10)
440L-C4J1280YD	440L-G4J1280YD	440L-F4J1280YD	14 (0.55)	128	1280 (50.39)	14.88 (6.75)
440L-C4J1440YD	440L-G4J1440YD	440L-F4J1440YD	14 (0.55)	144	1440 (56.69)	16.32 (7.40)
440L-C4J1600YD	440L-G4J1600YD	440L-F4J1600YD	14 (0.55)	160	1600 (62.99)	17.76 (8.06)
440L-C4J1760YD	440L-G4J1760YD	440L-F4J1760YD	14 (0.55)	176	1760 (69.29)	19.20 (8.71)
Hand Resolution						
440L-C4K0320YD	440L-G4K0320YD	440L-F4K0320YD	30 (1.18)	16	320 (12.59)	5.33 (2.42)
440L-C4K0480YD	440L-G4K0480YD	440L-F4K0480YD	30 (1.18)	24	480 (18.89)	6.88 (3.12)
440L-C4K0640YD	440L-G4K0640YD	440L-F4K0640YD	30 (1.18)	32	640 (25.19)	8.25 (3.74)
440L-C4K0800YD	440L-G4K0800YD	440L-F4K0800YD	30 (1.18)	40	800 (31.49)	9.63 (4.37)
440L-C4K0960YD	440L-G4K0960YD	440L-F4K0960YD	30 (1.18)	48	960 (37.79)	12.45 (5.65)
440L-C4K1120YD	440L-G4K1120YD	440L-F4K1120YD	30 (1.18)	56	1120 (44.09)	13.73 (6.23)
440L-C4K1280YD	440L-G4K1280YD	440L-F4K1280YD	30 (1.18)	64	1280 (50.39)	16.40 (7.44)
440L-C4K1440YD	440L-G4K1440YD	440L-F4K1440YD	30 (1.18)	72	1440 (56.69)	17.84 (8.10)
440L-C4K1600YD	440L-G4K1600YD	440L-F4K1600YD	30 (1.18)	80	1600 (62.99)	19.28 (8.75)
440L-C4K1760YD	440L-G4K1760YD	440L-F4K1760YD	30 (1.18)	88	1760 (69.29)	20.72 (9.40)

Table 40 - Resolution - Cascading GuardShield Safety Light Curtain with Integrated Laser Alignment

Sensor Pair	Transmitter	Receiver	Resolution [mm (in.)]	No. of Beams	Protective Heights [mm (in.)]	Pair Weight [kg (lb)]
Finger Resolution						
440L-C4JL0320YD	440L-G4JL0320YD	440L-F4JL0320YD	14 (0.55)	32	320 (12.59)	5.17 (2.35)
440L-C4JL0480YD	440L-G4JL0480YD	440L-F4JL0480YD	14 (0.55)	48	480 (18.89)	6.59 (2.99)
440L-C4JL0640YD	440L-G4JL0640YD	440L-F4JL0640YD	14 (0.55)	64	640 (25.19)	7.99(3.62)
440L-C4JL0800YD	440L-G4JL0800YD	440L-F4JL0800YD	14 (0.55)	80	800 (31.49)	9.43 (4.28)
440L-C4JL0960YD	440L-G4JL0960YD	440L-F4JL0960YD	14 (0.55)	96	960 (37.79)	12.21 (5.54)
440L-C4JL1120YD	440L-G4JL1120YD	440L-F4JL1120YD	14 (0.55)	112	1120 (44.09)	13.44 (6.10)
440L-C4JL1280YD	440L-G4JL1280YD	440L-F4JL1280YD	14 (0.55)	128	1280 (50.39)	14.88 (6.75)
440L-C4JL1440YD	440L-G4JL1440YD	440L-F4JL1440YD	14 (0.55)	144	1440 (56.69)	16.32 (7.40)
440L-C4JL1600YD	440L-G4JL1600YD	440L-F4JL1600YD	14 (0.55)	160	1600 (62.99)	17.76 (8.06)
Hand Resolution						
440L-C4KL0320YD	440L-G4KL0320YD	440L-F4KL0320YD	30 (1.18)	16	320 (12.59)	5.33 (2.42)
440L-C4KL0480YD	440L-G4KL0480YD	440L-F4KL0480YD	30 (1.18)	24	480 (18.89)	6.88 (3.12)
440L-C4KL0640YD	440L-G4KL0640YD	440L-F4KL0640YD	30 (1.18)	32	640 (25.19)	8.25 (3.74)
440L-C4KL0800YD	440L-G4KL0800YD	440L-F4KL0800YD	30 (1.18)	40	800 (31.49)	9.63 (4.37)
440L-C4KL0960YD	440L-G4KL0960YD	440L-F4KL0960YD	30 (1.18)	48	960 (37.79)	12.45 (5.65)
440L-C4KL1120YD	440L-G4KL1120YD	440L-F4KL1120YD	30 (1.18)	56	1120 (44.09)	13.73 (6.23)
440L-C4KL1280YD	440L-G4KL1280YD	440L-F4KL1280YD	30 (1.18)	64	1280 (50.39)	16.40 (7.44)
440L-C4KL1440YD	440L-G4KL1440YD	440L-F4KL1440YD	30 (1.18)	72	1440 (56.69)	17.84 (8.10)
440L-C4KL1600YD	440L-G4KL1600YD	440L-F4KL1600YD	30 (1.18)	80	1600 (62.99)	19.28 (8.75)

Table 41 - Resolution - Cascading GuardShield Safety Light Curtain with Integrated Laser Alignment and ArmorBlock I/O Connection

Sensor Pair	Transmitter	Receiver	Resolution [mm (in.)]	No. of Beams	Protective Heights [mm (in.)]	Pair Weight [kg (lb)]
Finger Resolution						
440L-C4JL0320YA	440L-G4JL0320YA	440L-F4JL0320YA	14 (0.55)	32	320 (12.59)	5.17 (2.35)
440L-C4JL0480YA	440L-G4JL0480YA	440L-F4JL0480YA	14 (0.55)	48	480 (18.89)	6.59 (2.99)
440L-C4JL0640YA	440L-G4JL0640YA	440L-F4JL0640YA	14 (0.55)	64	640 (25.19)	7.99(3.62)
440L-C4JL0800YA	440L-G4JL0800YA	440L-F4JL0800YA	14 (0.55)	80	800 (31.49)	9.43 (4.28)
440L-C4JL0960YA	440L-G4JL0960YA	440L-F4JL0960YA	14 (0.55)	96	960 (37.79)	12.21 (5.54)
440L-C4JL1120YA	440L-G4JL1120YA	440L-F4JL1120YA	14 (0.55)	112	1120 (44.09)	13.44 (6.10)
440L-C4JL1280YA	440L-G4JL1280YA	440L-F4JL1280YA	14 (0.55)	128	1280 (50.39)	14.88 (6.75)
440L-C4JL1440YA	440L-G4JL1440YA	440L-F4JL1440YA	14 (0.55)	144	1440 (56.69)	16.32 (7.40)
440L-C4JL1600YA	440L-G4JL1600YA	440L-F4JL1600YA	14 (0.55)	160	1600 (62.99)	17.76 (8.06)
Hand Resolution						
440L-C4KL0320YA	440L-G4KL0320YA	440L-F4KL0320YA	30 (1.18)	16	320 (12.59)	5.33 (2.42)
440L-C4KL0480YA	440L-G4KL0480YA	440L-F4KL0480YA	30 (1.18)	24	480 (18.89)	6.88 (3.12)
440L-C4KL0640YA	440L-G4KL0640YA	440L-F4KL0640YA	30 (1.18)	32	640 (25.19)	8.25 (3.74)
440L-C4KL0800YA	440L-G4KL0800YA	440L-F4KL0800YA	30 (1.18)	40	800 (31.49)	9.63 (4.37)
440L-C4KL0960YA	440L-G4KL0960YA	440L-F4KL0960YA	30 (1.18)	48	960 (37.79)	12.45 (5.65)
440L-C4KL1120YA	440L-G4KL1120YA	440L-F4KL1120YA	30 (1.18)	56	1120 (44.09)	13.73 (6.23)
440L-C4KL1280YA	440L-G4KL1280YA	440L-F4KL1280YA	30 (1.18)	64	1280 (50.39)	16.40 (7.44)
440L-C4KL1440YA	440L-G4KL1440YA	440L-F4KL1440YA	30 (1.18)	72	1440 (56.69)	17.84 (8.10)
440L-C4KL1600YA	440L-G4KL1600YA	440L-F4KL1600YA	30 (1.18)	80	1600 (62.99)	19.28 (8.75)

Disposal

The GuardShield safety light curtain is designed according to the main environmental protection directives (for example, RoHS). Always dispose of unserviceable devices in compliance with local/national rules and regulations.

Certification

See the Product Certification link at rok.auto/certifications for the Declaration of Conformity, Certificates, and other certification details.

- cULus Listed Industrial Control Equipment, which is certified for US and Canada
- CE Marked for all applicable directives (see [Declaration of Conformity](#))
- C-Tick Marked
- RCM marked (Australia)
- TÜV Nord Certified for Functional Safety up to SIL 3 for use in safety applications up to and including SIL CL 3 in accordance with EN 61508 and EN 62061, Performance Level e and Category 4 in accordance with ISO 13849-1, ESPE Type 4 safety light curtain in accordance with EN IEC 61496.

Declaration of Conformity

CE Conformity

Rockwell Automation B.V. (address: Rivium Promenade 160, 2909 LM Capelleaan den Ijssel, The Netherlands) declares that this product is in conformity with the provisions of the following EC directives (including all applicable amendments):

- 2014/30/EU EMC Directive (EMC)
- 2006/42/EC Machinery Directive (MD)

And that the respective standards and/or technical specifications have been applied. It is approved for installation within the European Union and M regions.

For a comprehensive CE certificate visit: rok.auto/certifications.

UKCA Conformity

Rockwell Automation declares that the products that are shown in this document are in compliance with UK Supply of Machinery (Safety) Regulations (2008 No. 1597), UK Electromagnetic Compatibility Regulations (2016 No. 1091), EMC Regulations (2016 No. 1091), and have Third-party Approval.

For a comprehensive UKCA certificate visit: rok.auto/certifications.

Rockwell Automation Support

Use these resources to access support information.

Technical Support Center	Find help with how-to videos, FAQs, chat, user forums, and product notification updates.	rok.auto/support
Knowledgebase	Access Knowledgebase articles.	rok.auto/knowledgebase
Local Technical Support Phone Numbers	Locate the telephone number for your country.	rok.auto/phonesupport
Literature Library	Find installation instructions, manuals, brochures, and technical data publications.	rok.auto/literature
Product Compatibility and Download Center (PCDC)	Download firmware, associated files (such as AOP, EDS, and DTM), and access product release notes.	rok.auto/pcdc

Documentation Feedback

Your comments help us serve your documentation needs better. If you have any suggestions on how to improve our content, complete the form at rok.auto/docfeedback.





Waste Electrical and Electronic Equipment (WEEE)



At the end of life, this equipment should be collected separately from any unsorted municipal waste.

Rockwell Automation maintains current product environmental compliance information on its website at rok.auto/pec.

Rockwell Otomasyon Ticaret A.Ş. Kar Plaza İş Merkezi E Blok Kat:6 34752 İçerenköy, İstanbul, Tel: +90 (216) 5698400 EEE Yönetmeliğine Uygundur

Connect with us.    

rockwellautomation.com — expanding **human possibility**[®]

AMERICAS: Rockwell Automation, 1201 South Second Street, Milwaukee, WI 53204-2496 USA, Tel: (1) 414.382.2000, Fax: (1) 414.382.4444

EUROPE/MIDDLE EAST/AFRICA: Rockwell Automation NV, Pegasus Park, De Kleetlaan 12a, 1831 Diegem, Belgium, Tel: (32) 2 663 0600, Fax: (32) 2 663 0640

ASIA PACIFIC: Rockwell Automation, Level 14, Core F, Cyberport 3, 100 Cyberport Road, Hong Kong, Tel: (852) 2887 4788, Fax: (852) 2508 1846

UNITED KINGDOM: Rockwell Automation Ltd. Pitfield, Kiln Farm Milton Keynes, MK11 3DR, United Kingdom, Tel: (44)(1908) 838-800, Fax: (44)(1908) 261-917

Allen-Bradley, ArmorBlock, expanding human possibility, Guardmaster, Guard I/O, GuardShield, and Rockwell Automation are trademarks of Rockwell Automation, Inc.

Trademarks not belonging to Rockwell Automation are property of their respective companies.