

AIT CONNECTOR

Board-to-wire/Wire-to-wire



0.64 unsealed connector series compliant with the standard USCAR footprints.
Variations of Keying / Color options and PC Board mounting features are available to satisfy customer's needs.

Features

- Compliant with the Standard 0.64 Unsealed USCAR Footprints and USCAR Performance Standards
- Variations in PCB mountings

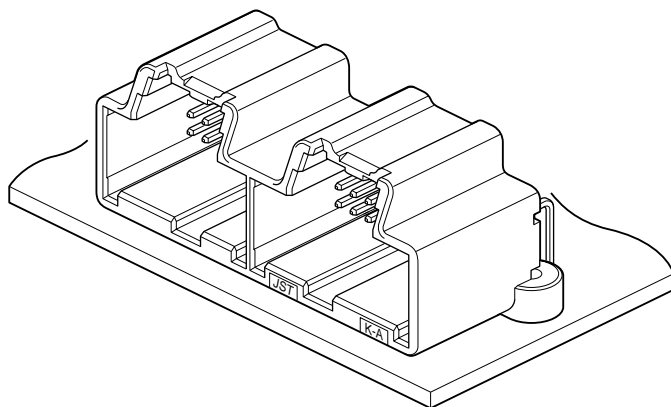

Specifications

- Current rating: 5 A DC max.
- Voltage rating: 14 V DC
- Temperature range: -40°C to +100°C
(including temperature rise in applying electrical current)
- Contact resistance: Initial value/ 15 mΩ max.
After environmental tests/ 15 mΩ max.
- Insulation resistance: 100 MΩ min.
- Applicable wire: SAE/ AVSS / CAVS
0.3 mm² to 0.8 mm²

* Compliant with ELV/RoHS.
* Contact JST for details.

Female terminal

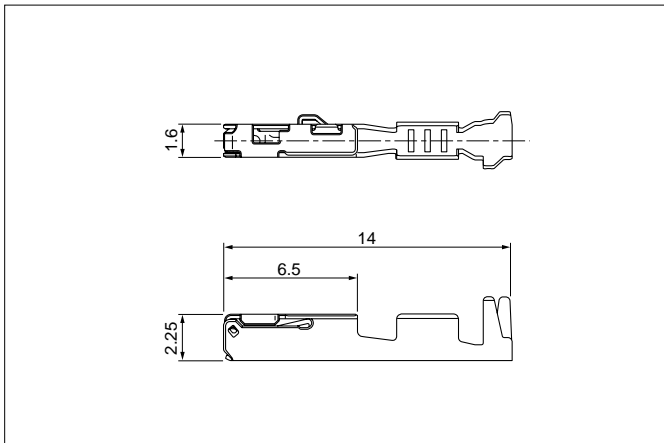

Size	Model No.	Applicable wire range		Q'ty/reel
		Conductor (mm ²)	Insulation O.D. (mm)	
S	①SAIT-A03T-M064	0.3 to 0.5	≤1.9	6,500
	②SAIT-A03GF-M064	0.3 to 0.5	≤1.9	6,500
M	①SAIT-A02T-M064	0.75 to 0.8	≤1.9	6,500
	②SAIT-A02GF-M064	0.75 to 0.8	≤1.9	6,500

Material and Finish

- ①Copper alloy, tin-plated (reflow treatment)
- ②Copper alloy, Contact area; gold-plated
Barrel area; tin-plated

Male terminal

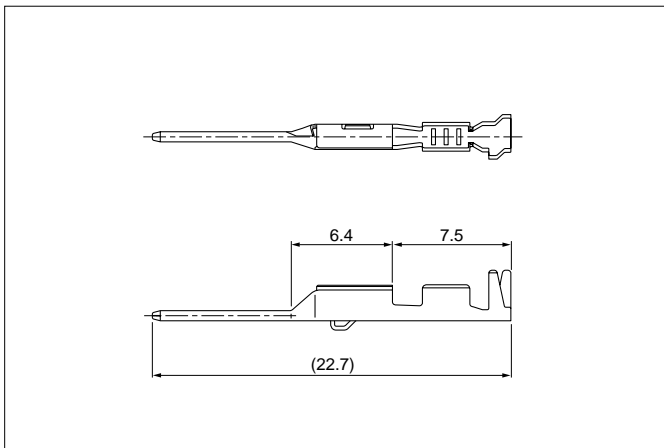

Size	Model No.	Applicable wire range		Q'ty/reel
		Conductor (mm ²)	Insulation O.D. (mm)	
S	①SAITW-A03T-064	0.3 to 0.5	≤1.9	9,000
	②SAITW-A03GF-064	0.3 to 0.5	≤1.9	9,000
M	①SAITW-A02T-064	0.75 to 0.8	≤1.9	7,000
	②SAITW-A02GF-064	0.75 to 0.8	≤1.9	7,000

Material and Finish

- ①Brass, tin-plated (reflow treatment)
- ②Brass, Contact area; gold-plated
Barrel area; tin-plated

Female Connector

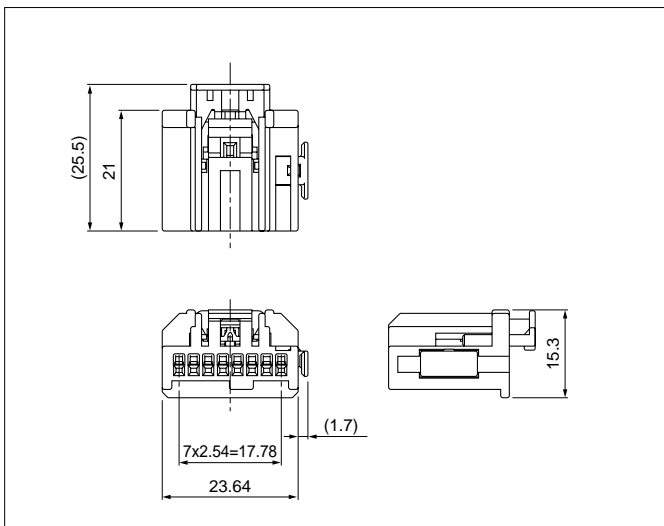

Circuits	Model No.	Q'ty/box
8	AITPB-C08-1A-K	1,500

Material

- Housing: Glass-filled PBT, Black
- TPA: Glass-filled PBT, Red
- CPA: Glass-filled PBT, Red

AIT CONNECTOR

Male connector (Top entry type)

With boss ● 20 circuits

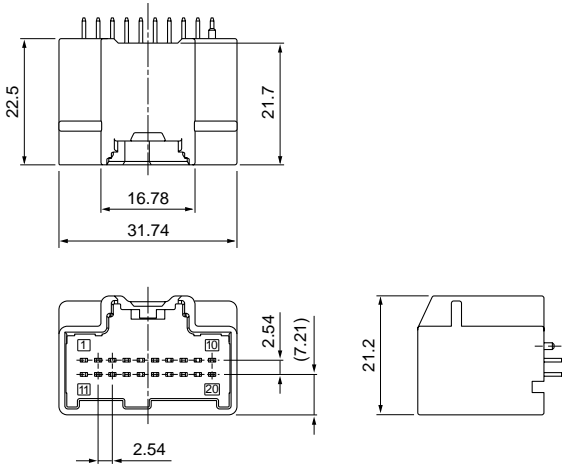

Screw hole type ● 8 circuits

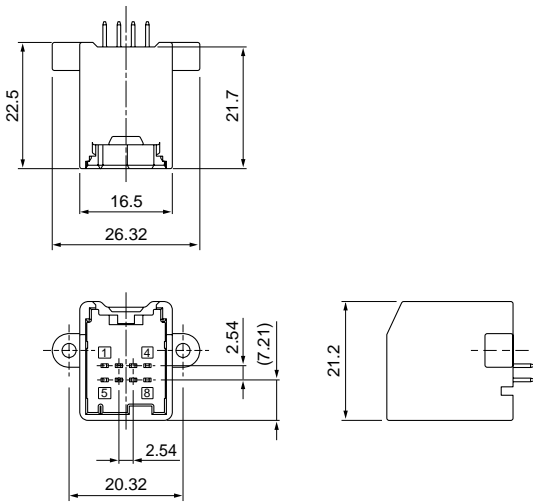

● 16 circuits

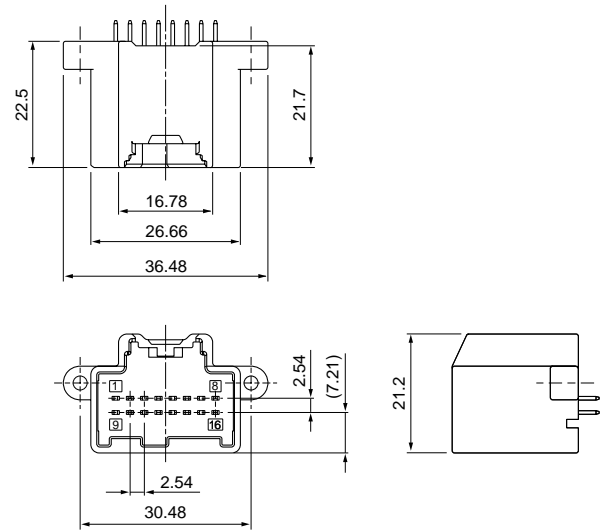

● 18 circuits

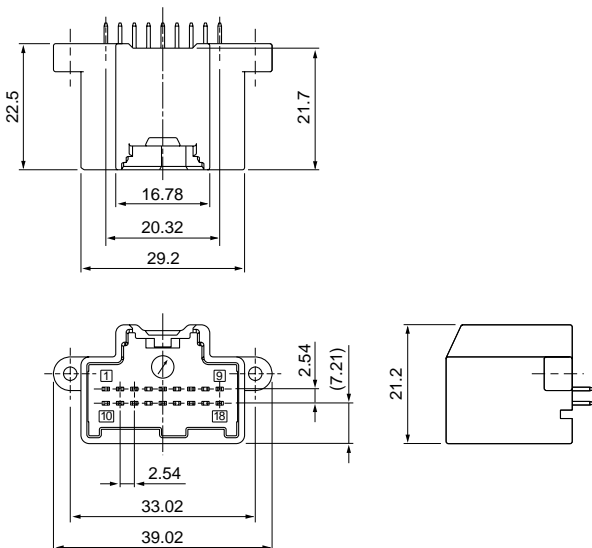

PCB Mounting Style	Circuits	Model No.	Q ty/box	Housing Color
Boss	20	B20B2-AIT-A2A-KS	700	Black
		B20B2-AIT-A2C-NS	700	Brown
Screw hole	8	B08B-AIT-A2A-KS	810	Black
		B08B-AIT-A2B-HS	810	Gray
	16	B16B-AIT-A2A-KS	600	Black
		B16B-AIT-A2B-HS	600	Black
18	B18B-AIT-A2F-SS	600	Natural (White)	

Material and Finish

Housing: Glass-filled PA
Pin: Brass, tin-plated

Male connector (Side entry type)

Screw hole type

● 10 circuits

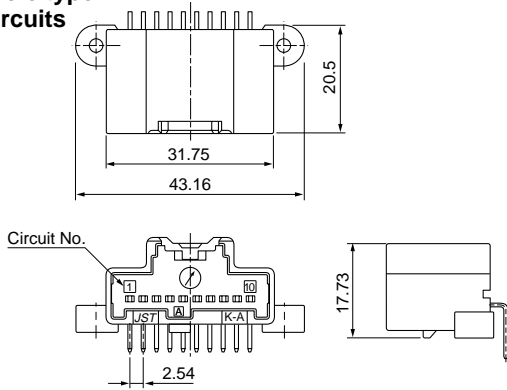

● 20 circuits

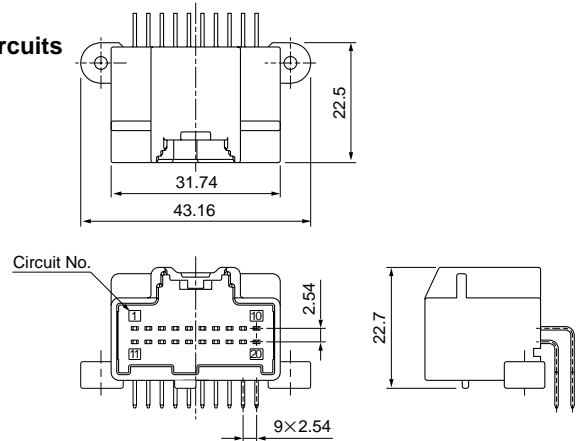

● 34 circuits

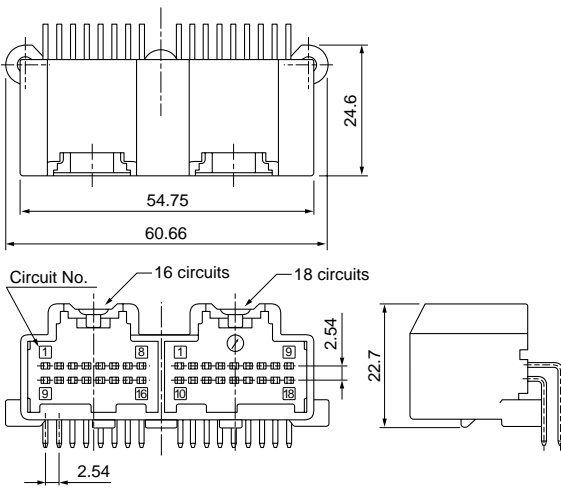

● 52 circuits

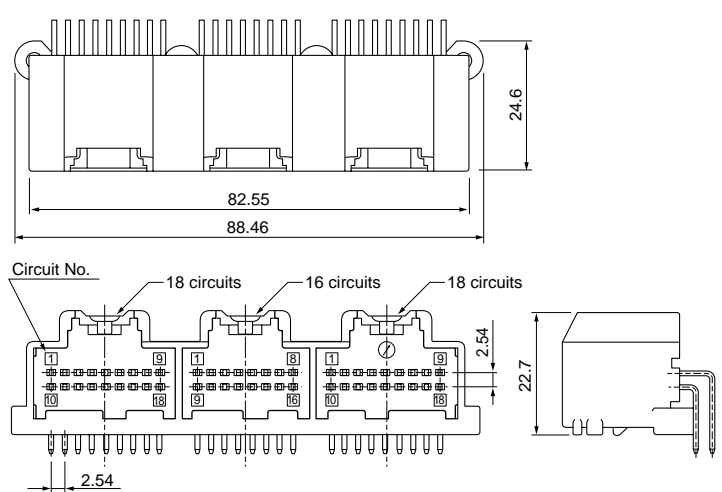

Reinforcement type

● 4 circuits

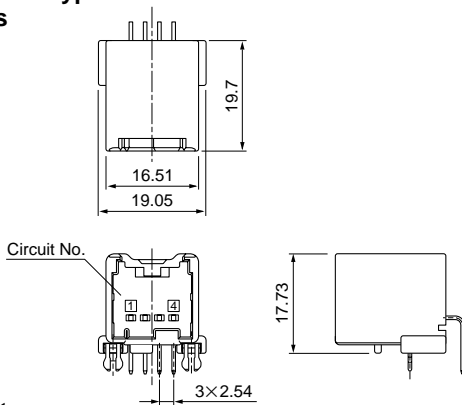

● 8 circuits

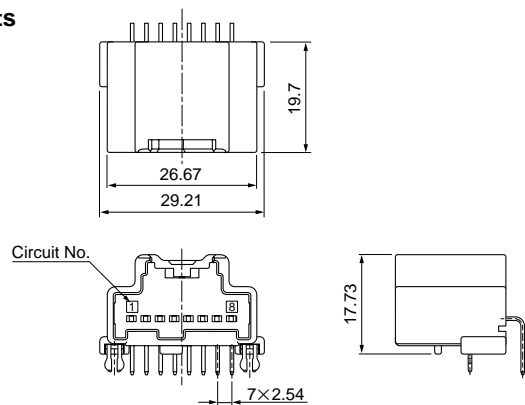

● 20 circuits

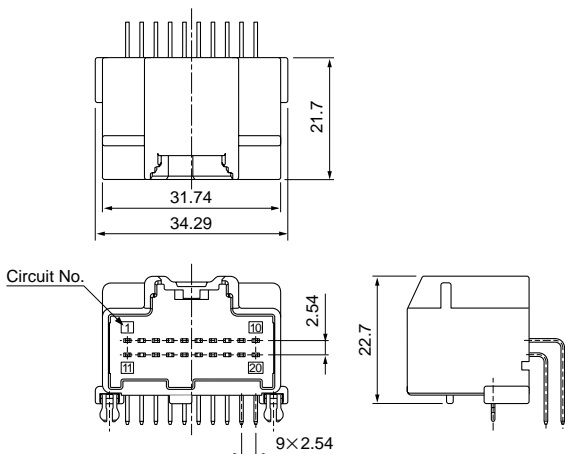

PCB Mounting Style	Circuits	Model No.	Q ty/box	Housing Color
Screw hole	10	S10B-AIT-A1A-KS(M)(LF)(SN)	585	Black
	20	S20B-AIT-A2A-KS	336	Black
		S20B-AIT-A2B-HS	336	Gray
	34	S34B-AIT-A22-SS(M)(LF)(SN)	252	Natural (White)
	52	S52B-AIT-A23-SS(M)(LF)(SN)	168	Natural (White)
* Reinforcement	4	S04B1-AIT-A1A-KS	880	Black
	8	S08B1-AIT-A1A-KS	560	Black
	20	S20B1-AIT-A2A-KS	360	Black
S20B1-AIT-A2B-HS		360	Gray	

Material and Finish
Housing: Glass-filled PBT
Pin: Brass, tin-plated
*Reinforcement: Brass, tin-plated

AIT CONNECTOR

Male connector (Wire-to-wire type)

● 10 circuits

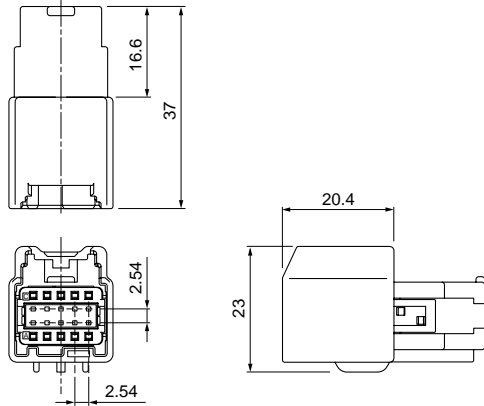

Circuits	Model No.	Q'ty/box
10	AITWSB-10-2AK	100
Material		
Housing: Glass-filled PBT, Black		
TPA: Glass-filled PBT, Red		

PC board layout

Top entry type

With boss
● 20 circuits

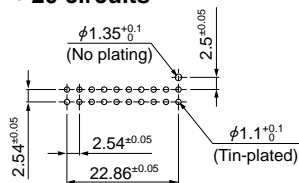

Screw hole type
● 8 circuits

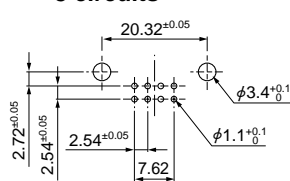

● 16 circuits

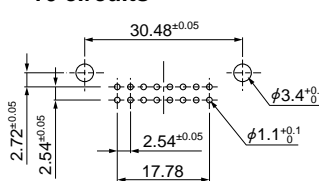

● 18 circuits

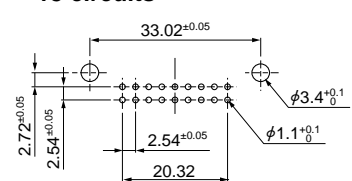

Side entry type Screw hole type ● 10 circuits

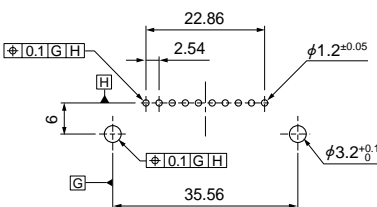

● 20 circuits

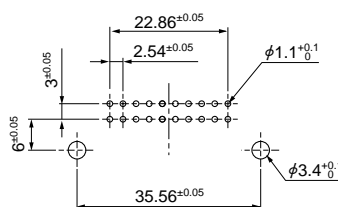

● 34 circuits

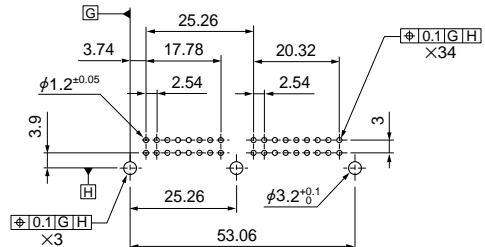

Reinforcement type ● 4 circuits

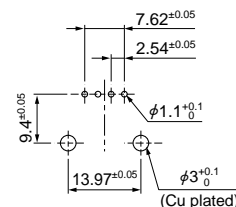

● 8 circuits

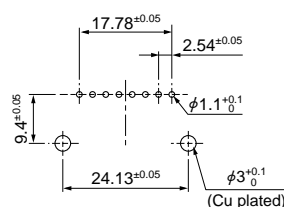

● 20 circuits

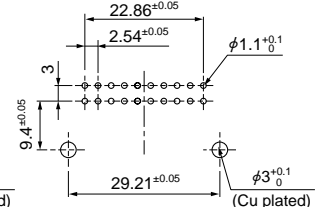

● 52 circuits

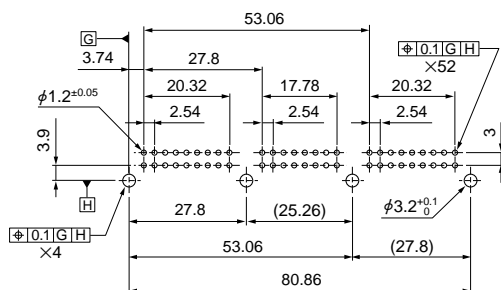

Note: 1. Tolerances are non-cumulative.
2. Hole dimensions differ according to the type of PC board and piercing method.
The dimensions above should serve as guideline. Contact JST for details.

Crimping machine, Applicator

Strip terminal	Crimping machine	Crimp applicator MKS-L	
		Dies	Crimp applicator with dies
SAIT-A03()-M064	AP-K2N	MK/SAIT-A03-064	APLMK SAIT-A03-064
SAIT-A02()-M064		MK/SAIT-A02-064	APLMK SAIT-A02-064
SAITW-A03()-064		MK/SAITW-A03-064	APLMK SAITW-A03-064
SAITW-A02()-064		MK/SAITW-A02-064	APLMK SAITW-A02-064

Note: When crimping operation is conducted using an applicator and die set other than the above, JST cannot guarantee the performance of the terminal.