

RFC CONNECTOR

Disconnectable Crimp style Wire-to-wire connectors

Single row Signal circuit type

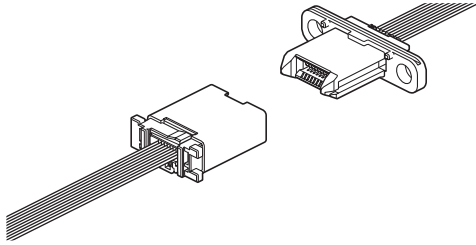

Single row Hybrid type

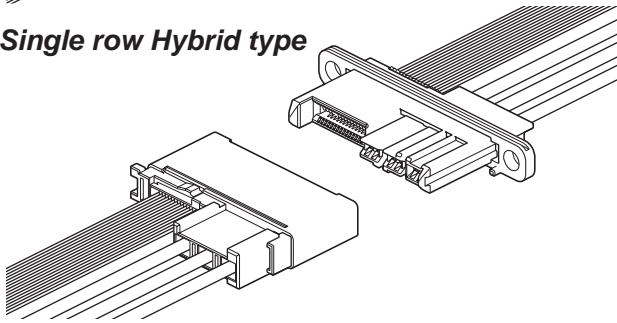

Double rows Signal circuit type

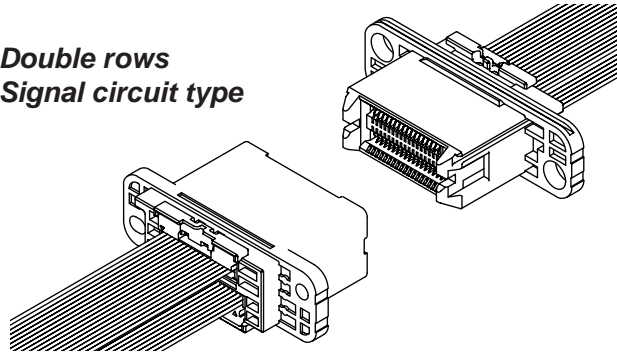

Double rows Hybrid type

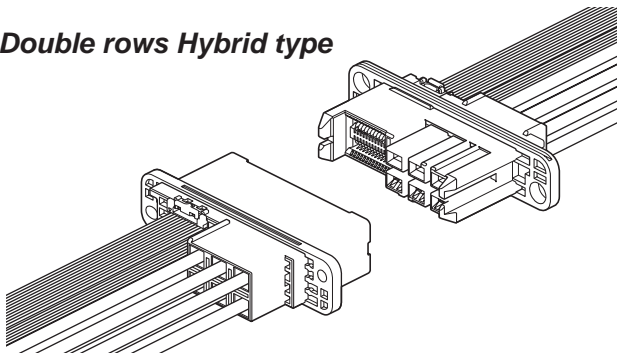

Signal/hybrid type drawer connector for unit connection. The RFC connector absorbs misalignment between the two units and also excels in durability. The contact reliability has been enhanced by reviewing contact structure.

Specifications

- Current rating: Signal circuit 1.0 A AC, DC (AWG #26, AWG #27)
Power supply circuit 15 A AC, DC (AWG #14)
 - Voltage rating: Signal circuit 50 V AC, DC
Power supply circuit 250 V AC, DC
 - Temperature range: -25°C to +85°C
(including temperature rise in applying electrical current)
 - Contact resistance:

Signal circuit	Initial value/ 40 mΩ max.
	After environmental tests/ 60 mΩ max.
Power supply circuit	Initial value/ 10 mΩ max.
	After environmental tests/ 20 mΩ max.
 - Insulation resistance: 500 MΩ min.
 - Withstanding voltage: Signal circuit 500 VAC
Power supply circuit 1,500 VAC
 - Applicable wire:

Power supply circuit	Conductor size/ AWG #22 to #14
	Insulation O.D./ 1.55 to 3.6 mm
Plug signal circuit	Conductor size/ AWG #30 to #26
	Insulation O.D./ 0.6 to 0.8 mm
Receptacle signal circuit	Applicable socket/ CSR, CSH connectors
 - Durability: 5,000 cycles
- * Refer to "General Instruction and Notice when using Terminals and Connectors" at the end of this catalog.
* Contact JST for details.
* Compliant with RoHS.

Standards

Recognized E60389

J50272912

RFC CONNECTOR

Panel layout and Assembly layout

Single row Signal circuit type

Plug Panel thickness: $t2.0$

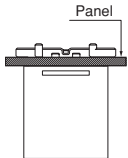
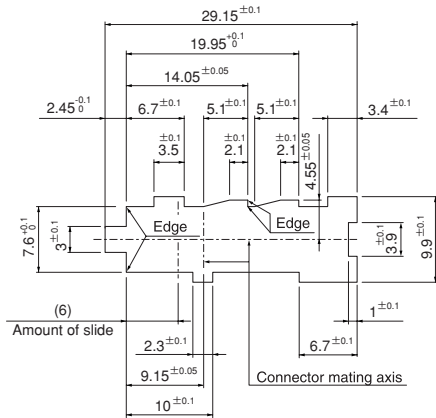
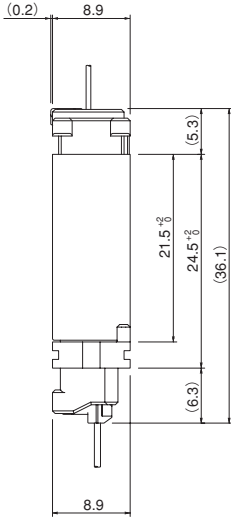

Receptacle Panel thickness: $t0.8 \sim t2.0$

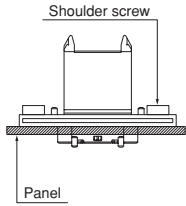
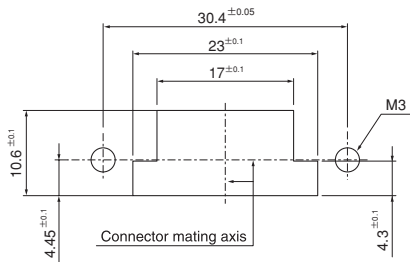
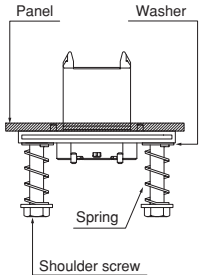
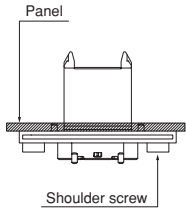
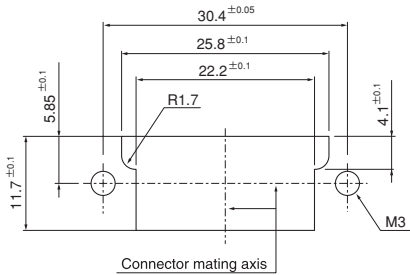

Mating circuit

	No. of circuits
Plug signal unit	1
RFc receptacle	1
CSH/CSR	1
	No. of circuits
Plug contact for power supply circuit	1
Receptacle contact for power supply circuit	1

RFC CONNECTOR

Panel layout and Assembly layout

Single row Hybrid type

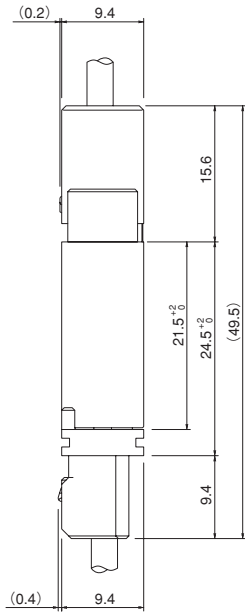

Plug

Panel thickness: $t1.0$

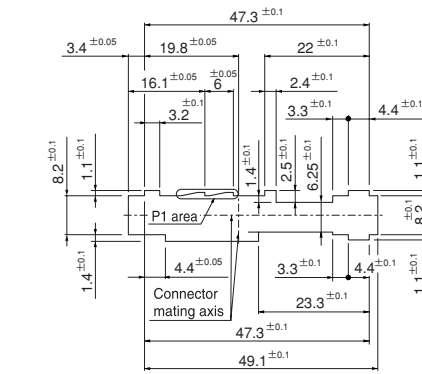

Details of P1 area

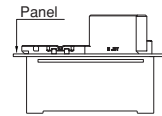
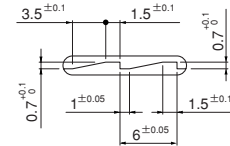

Panel thickness: $t2.0$

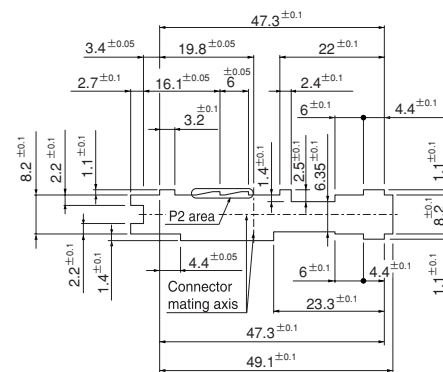

Details of P2 area

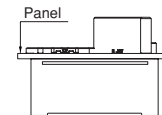
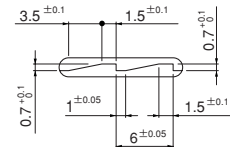

Receptacle

Panel thickness: $t0.8 \sim t2.0$

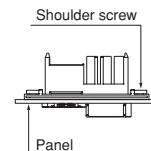
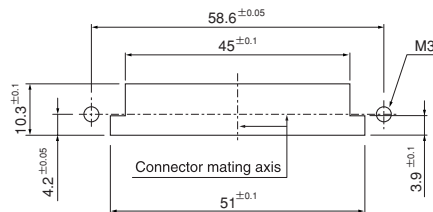
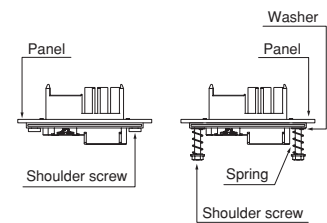
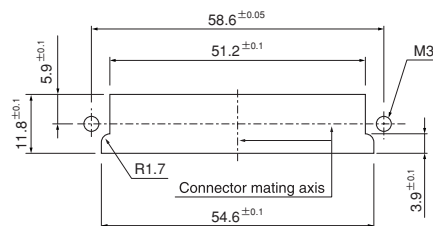

Mating circuit

	No. of circuits
Plug signal unit	1
RFc receptacle	1
CSH/CSR	1
	No. of circuits
Plug contact for power supply circuit	1
Receptacle contact for power supply circuit	1

Panel layout and Assembly layout

Double rows Signal circuit type

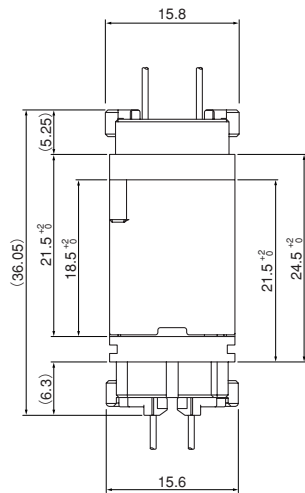

Double rows Hybrid type

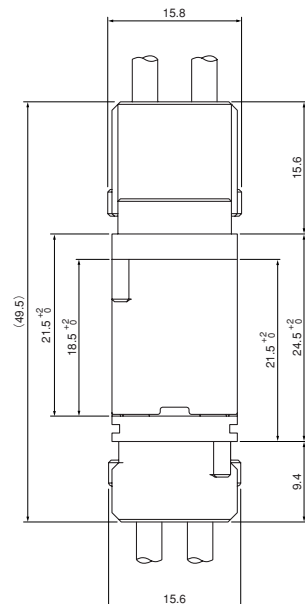

Mating circuit

	No. of circuits
Plug signal unit	1
RFC receptacle	1
CSH/CSR	1
	No. of circuits
Plug contact for power supply circuit	1
Receptacle contact for power supply circuit	1

Plug

Panel thickness: $t0.8 \sim t2.0$

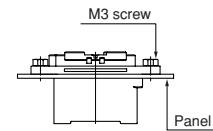
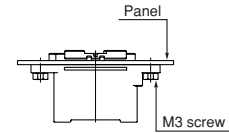
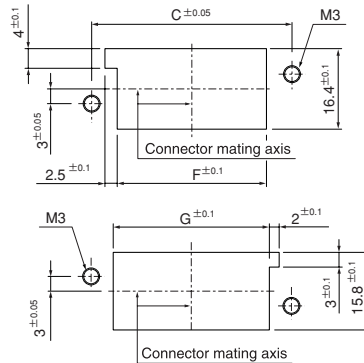

Note) C, F and G dimensions: Refer to page 6.

Receptacle

Panel thickness: $t0.8 \sim t2.0$

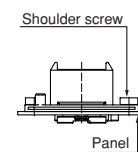
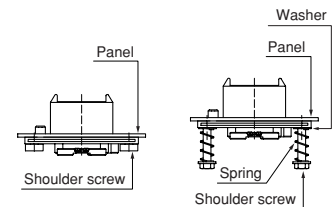
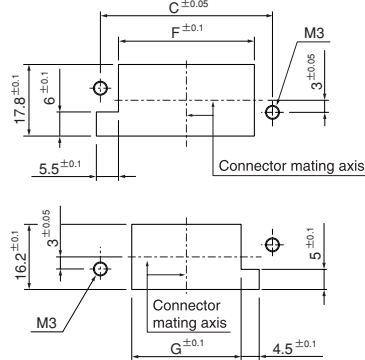

Note) C, F and G dimensions: Refer to page 7.

Plug

Panel thickness: $t0.8 \sim t2.0$

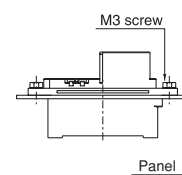
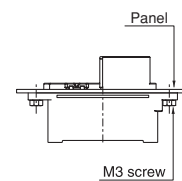
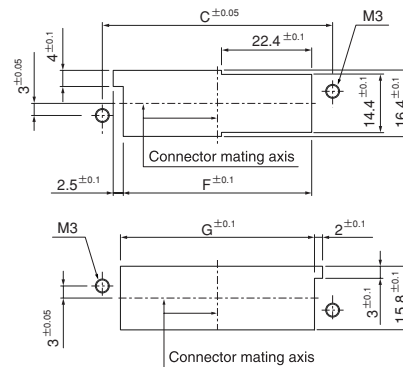

Note) C, F and G dimensions: Refer to page 6.

Receptacle

Panel thickness: $t0.8 \sim t2.0$

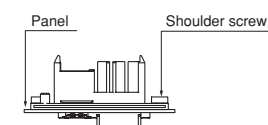
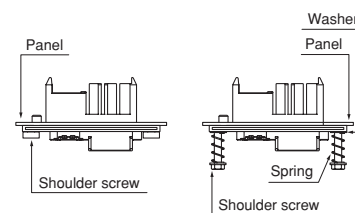
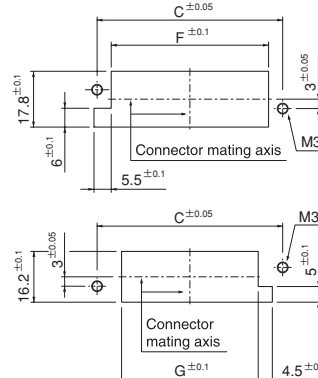

Note) C, F and G dimensions: Refer to page 7.

Note: 1. Punch holes in the panel according to the figures shown above. Burrs must be removed.
2. The strength of the panel must be considered when punching two or more holes.
3. The connector must be inserted from the same side as the hole is punched.

RFC CONNECTOR

Plug contact for power supply circuit

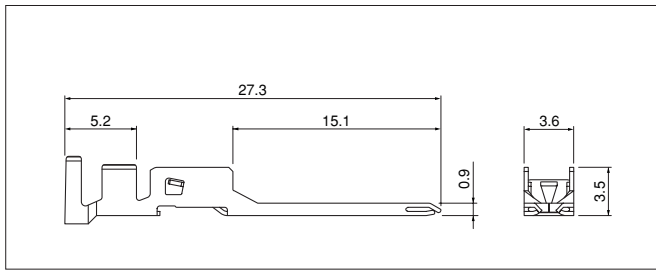

Model No.	Applicable wire		Insulation O.D. (mm)	Q'ty/reel
	mm ²	AWG#		
SRFM-01GG-S0.9	0.3~0.5	22~20	1.55~3.1	3,500
SRFM-61GG-S0.9	0.75~2.0	18~14	2.0~3.6	3,500

Material and Finish

Copper alloy, nickel-undercoated, Contacting part; gold-plated
Crimping part; tin-plated (reflow treatment)

RoHS compliance This product displays (LF)(SN) on a label.

Contact	Crimping machine	Applicator		
		Crimp applicator	Dies	Crimp applicator with dies
SRFM-01GG-S0.9	AP-K2N	MKS-L	MK/SRFF/M-01-09	APLMK SRFF/M01-09
SRFM-61GG-S0.9			MK/SRFF/M-61-09	APLMK SRFF/M61-09

Note: Contact JST for fully automatic crimping applicator.

Receptacle contact for power supply circuit

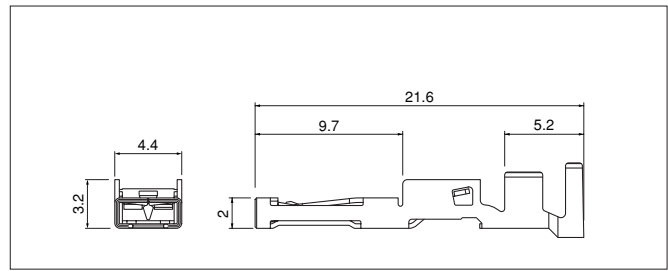

Model No.	Applicable wire		Insulation O.D. (mm)	Q'ty/reel
	mm ²	AWG#		
SRFF-01GG-S0.9	0.3~0.5	22~20	1.55~3.1	3,500
SRFF-61GG-S0.9	0.75~2.0	18~14	2.0~3.6	3,500

Material and Finish

Copper alloy, nickel-undercoated, Contacting part; gold-plated
Crimping part; tin-plated (reflow treatment)

RoHS compliance This product displays (LF)(SN) on a label.

Contact	Crimping machine	Applicator		
		Crimp applicator	Dies	Crimp applicator with dies
SRFF-01GG-S0.9	AP-K2N	MKS-L	MK/SRFF/M-01-09	APLMK SRFF/M01-09
SRFF-61GG-S0.9			MK/SRFF/M-61-09	APLMK SRFF/M61-09

Note: Contact JST for fully automatic crimping applicator.

Plug contact for power supply circuit

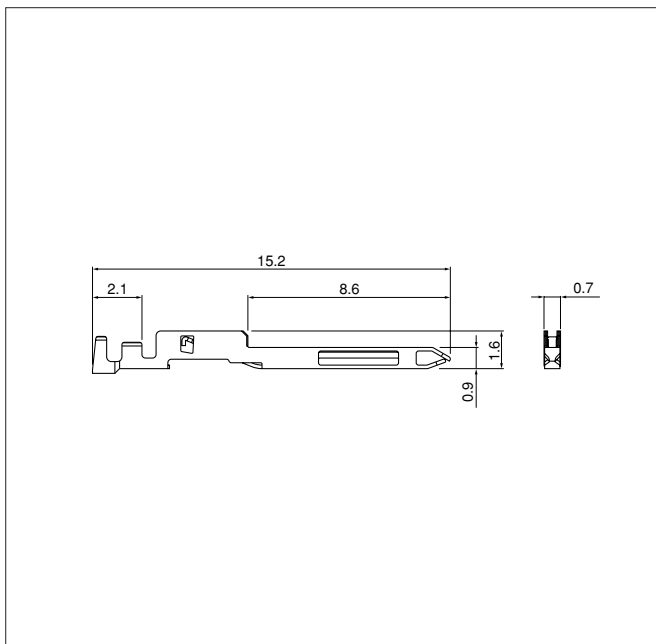

Model No.	Applicable wire		Insulation O.D. (mm)	Q'ty/reel
	mm ²	AWG#		
SRFCP-002GG-M0.9	0.05~0.13	30~26	0.6~0.8	18,000

Material and Finish

Copper alloy, nickel-undercoated, Contacting part; gold-plated
Crimping part; tin-plated (reflow treatment)

RoHS compliance This product displays (LF)(SN) on a label.

Contact	Crimping machine	Applicator		
		Crimp applicator	Dies	Crimp applicator with dies
SRFCP-002GG-M0.9	AP-K2N	MKS-L-10-3	MK/SRFCP-002-09	APLMK SRFCP002-09

Note: Contact JST for fully automatic crimping applicator.

Receptacle contact for power supply circuit

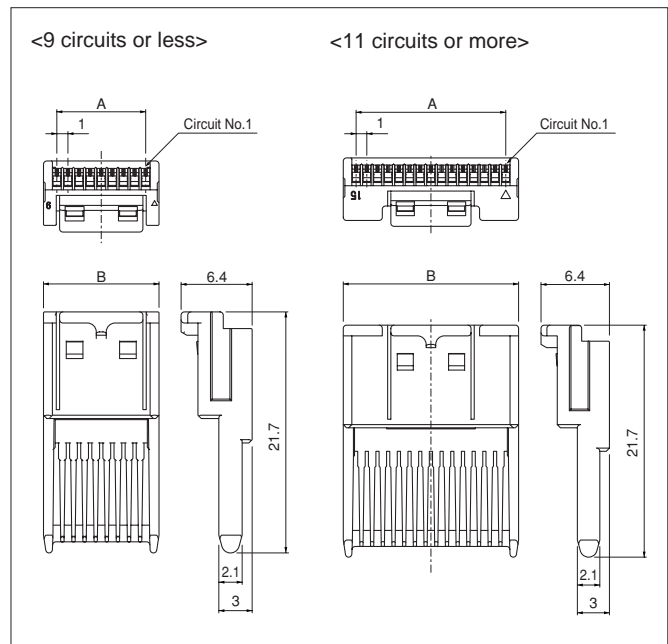

No. of circuits	Model No.	Dimensions (mm)		Q'ty/box
		A	B	
9	RFCYP-09-Z-S	8.0	10.4	8,400
11	RFCYP-11-Z	10.0	12.4	7,200
13	RFCYP-13-Z	12.0	14.4	6,000
15	RFCYP-15-Z	14.0	16.4	5,200
17	RFCYP-17-Z	16.0	18.4	4,800
19	RFCYP-19-Z	18.0	20.4	4,400
21	RFCYP-21-Z	20.0	22.4	4,000
23	RFCYP-23-Z	22.0	24.4	3,600

Material

LCP, UL94V-0, natural

RoHS compliance

RFC CONNECTOR

Plug

Single row Signal circuit type

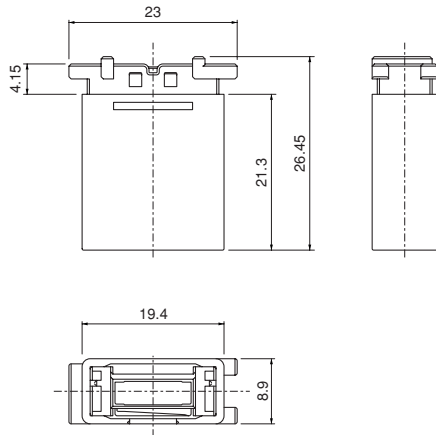

Single row Hybrid type

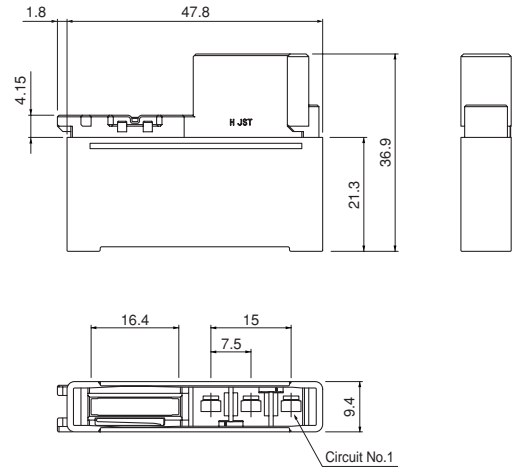

No. of circuits		Model No.	Q'ty/box
Power supply	Signal		
None	9	RFCP-09S0-RJ-M	1,620

Material

PBT · UL94V-0, green

No. of circuits		Model No.	Q'ty/box
Power supply	Signal		
3	15	RFCP-15S3-SRL-K	360

Material

LCP · UL94V-0, black

RoHS compliance

RoHS compliance

Double rows Signal circuit type

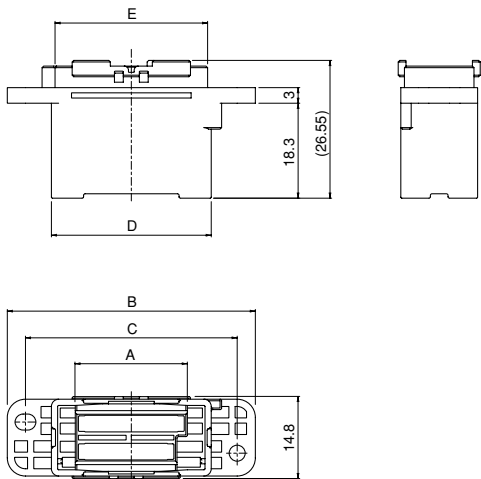

Double rows Hybrid type

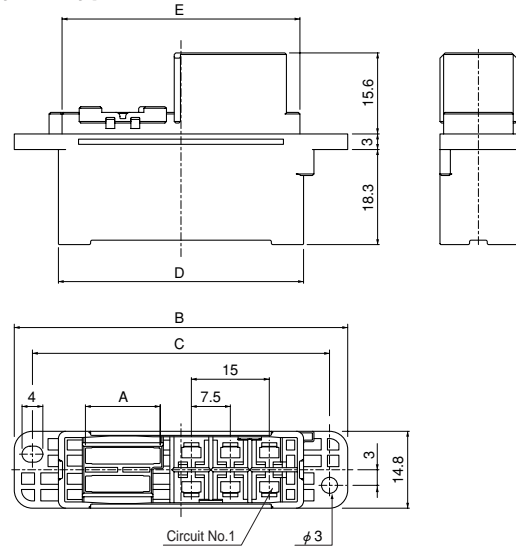

No. of circuits	Power supply	Signal	Model No.	Dimensions (mm)							Q'ty/box
				A	B	C	D	E	F	G	
None	28		RFCP-28W0-E	16.4	43.8	36.8	26.8	25.4	26.4	27.8	400
None	36		RFCP-36W0-E	20.4	47.8	40.8	30.8	29.4	30.4	31.8	400
None	44		RFCP-44W0-E	24.4	51.8	44.8	34.8	33.4	34.4	35.8	350

Material

PBT, UL94V-0, blue

No. of circuits	Power supply	Signal	Model No.	Dimensions (mm)							Q'ty/box
				A	B	C	D	E	F	G	
6	24		RFCP-24W6-E	14.4	64.2	57.2	47.2	45.8	46.8	48.2	200
6	36		RFCP-36W6-E	20.4	70.2	63.2	53.2	51.8	52.8	54.2	200

Material

PBT, UL94V-0, blue

RoHS compliance

Note: F and G dimensions; Refer to the panel layout (page 4).

RoHS compliance

Note: F and G dimensions; Refer to the panel layout (page 4).

RFC CONNECTOR

Receptacle

Single row Signal circuit type

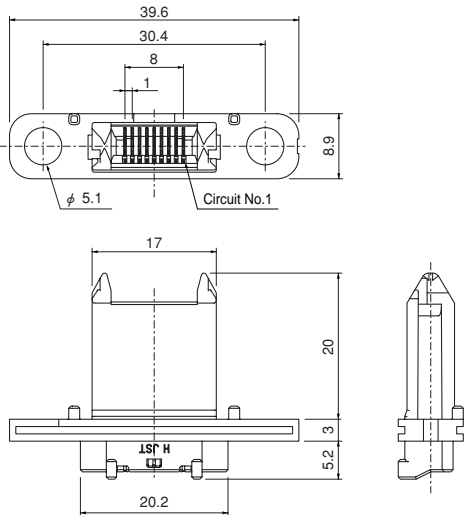

Single row Hybrid type

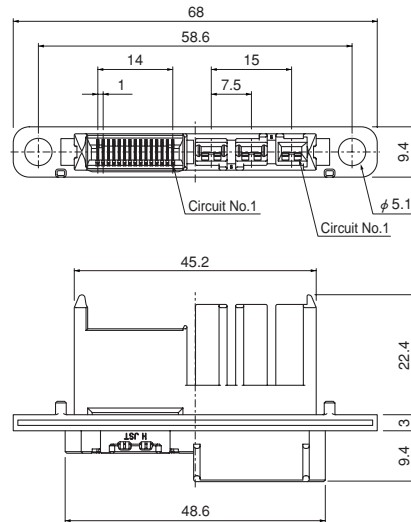

No. of circuits		Model No.	Q'ty/box
Power supply	Signal		
None	9	09S0R-RFC-MGD	576

Material and Finish

Signal contact: Copper alloy, nickel-undercoated, selective gold-plated tin-plated (reflow treatment)
Housing: PBT, UL94V-0, green

No. of circuits		Model No.	Q'ty/box
Power supply	Signal		
3	15	15S3R-RFC-SKGD	340

Material and Finish

Signal contact: Copper alloy, nickel-undercoated, selective gold-plated tin-plated (reflow treatment)
Housing: LCP, UL94V-0, black

RoHS compliance This product displays (LF)(SN) on a label.

RoHS compliance This product displays (LF)(SN) on a label.

Double rows Signal circuit type

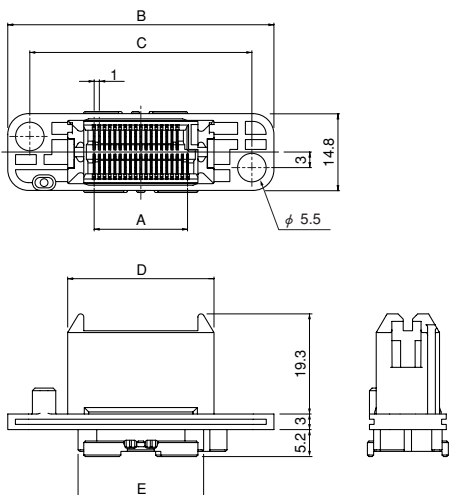

Double rows Hybrid type

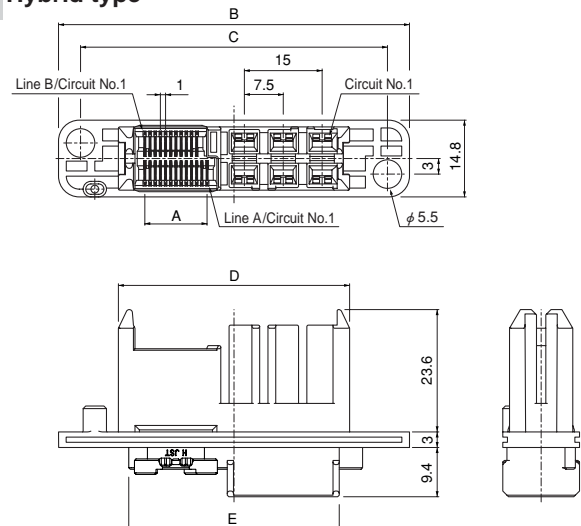

No. of circuits	Model No.	Dimensions (mm)							Q'ty/box
		A	B	C	D	E	F	G	
None	28W0R-RFC-EGD	14.0	47.3	38.8	24.2	20.2	29.8	23.2	400
None	36W0R-RFC-EGD	18.0	51.3	42.8	28.2	24.2	33.8	27.2	350
None	44W0R-RFC-EGD	22.0	55.3	46.8	32.2	28.2	37.8	31.2	300

Material and Finish

Signal contact: Copper alloy, nickel-undercoated, selective gold-plated tin-plated (reflow treatment)
Housing: PBT, UL94V-0, blue

RoHS compliance This product displays (LF)(SN) on a label.
Note: F and G dimensions; Refer to the panel layout (page 4).

No. of circuits	Model No.	Dimensions (mm)							Q'ty/box
		A	B	C	D	E	F	G	
6	24W6R-RFC-EGD-1G	12.0	67.7	59.2	44.6	40.6	50.2	43.6	200
6	36W6R-RFC-EGD-1G	18.0	73.7	65.2	50.6	46.6	56.2	49.6	160

Material and Finish

Signal contact: Copper alloy, nickel-undercoated, selective gold-plated tin-plated (reflow treatment)
Housing: PBT, UL94V-0, blue

RoHS compliance This product displays (LF)(SN) on a label.
Note: F and G dimensions; Refer to the panel layout (page 4).

RFC CONNECTOR

CSR connector socket

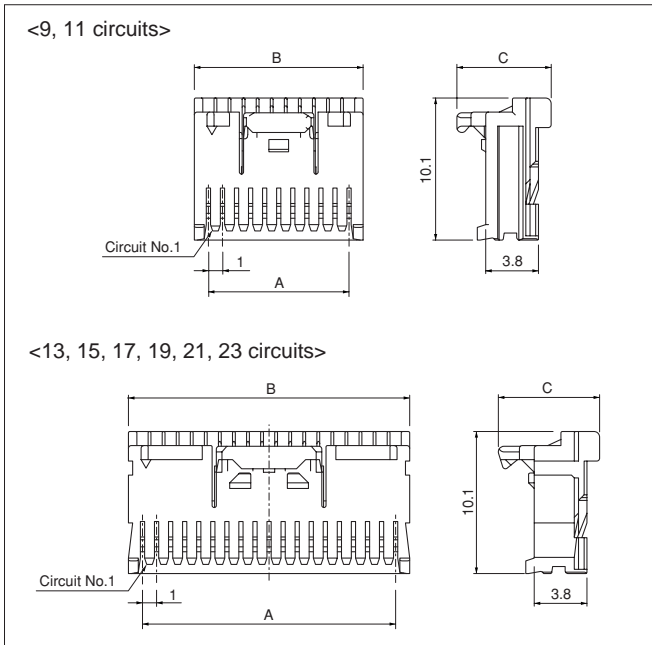

No. of circuits	Model No.	Dimensions (mm)			Q'ty/box
		A	B	C	
9	09CSR-8PK	8.0	10.0	6.7	5,400
11	11CSR-8PK	10.0	12.0	6.7	4,500
13	13CSR-8PK	12.0	14.0	7.2	3,780
15	15CSR-8PK	14.0	16.0	7.2	3,240
17	17CSR-8PK	16.0	18.0	7.2	2,880
19	19CSR-8PK	18.0	20.0	7.2	2,700
21	21CSR-8PK	20.0	22.0	7.2	2,340
23	23CSR-8PK	22.0	24.0	7.2	2,160

Material and Finish

Contact: Copper alloy, tin-plated
Housing: PBT, UL94V-0, pink

RoHS compliance This product displays (LF)(SN) on a label.

CSH connector contact

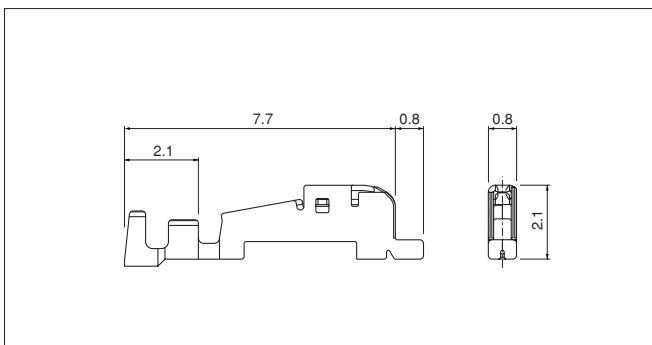

Model No.	Applicable wire		Insulation O.D. (mm)	Q'ty/reel
	mm ²	AWG#		
SCSH-002T-P0.2N	0.05~0.13	30~26	0.6~0.8	12,000

Material and Finish

Copper alloy, tin-plated (reflow treatment)

RoHS compliance This product displays (LF)(SN) on a label.

Contact	Crimping machine	Applicator		
		Crimp applicator	Dies	Crimp applicator with dies
SCSH-002T-P0.2N	AP-K2N	MKS-L-10-3	MK/SCSH-002-02	APLMK SCSH002-02

Note: Contact JST for fully automatic crimping applicator.

CSH connector housing

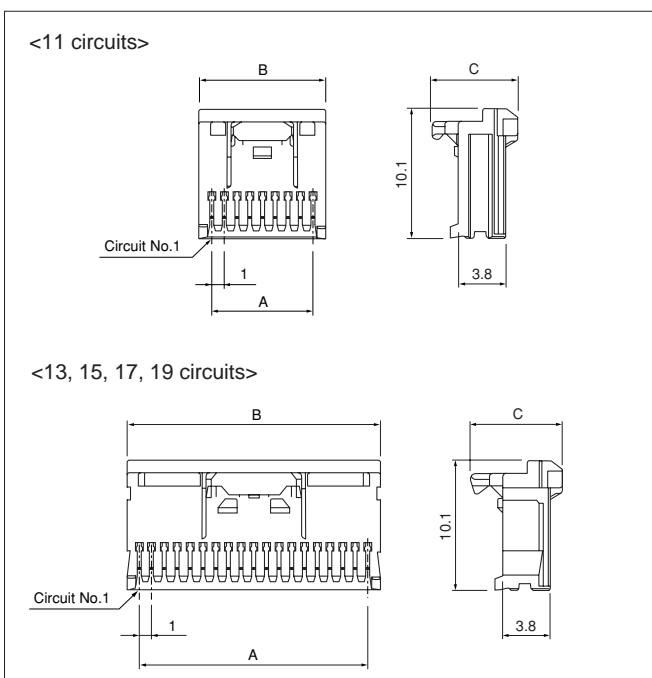

No. of circuits	Model No.	Dimensions (mm)			Q'ty/box
		A	B	C	
11	CSH-11-PK-N	10.0	12.0	6.7	10,000
13	CSH-13-PK-N	12.0	14.0	7.2	10,000
15	CSH-15-PK-N	14.0	16.0	7.2	10,000
17	CSH-17-PK-N	16.0	18.0	7.2	5,000
19	CSH-19-PK-N	18.0	20.0	7.2	5,000

Material

Housing: PBT, UL94V-0, pink

RoHS compliance