

Installation Instructions



Note:
This instruction outlines the recommended general installation procedure. For installation by a qualified person, as defined by all local electrical codes and/or the National Electrical Code®.

Prepare Enclosure

Remove Knockouts. Required knockouts may be removed prior to mounting enclosure. On multiple ring knockout design, first remove center section by striking at point furthest from tie (Figure 1). Bend back and forth to break tie. Remove large rings, one at a time, by prying with screwdriver and bending back and forth with pliers, as shown in Figure 2.

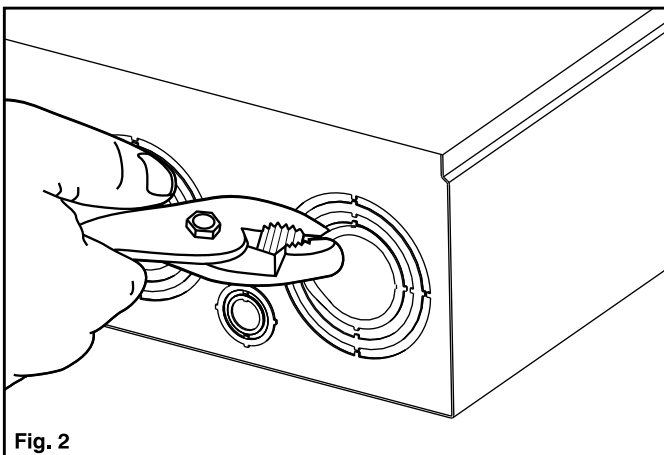
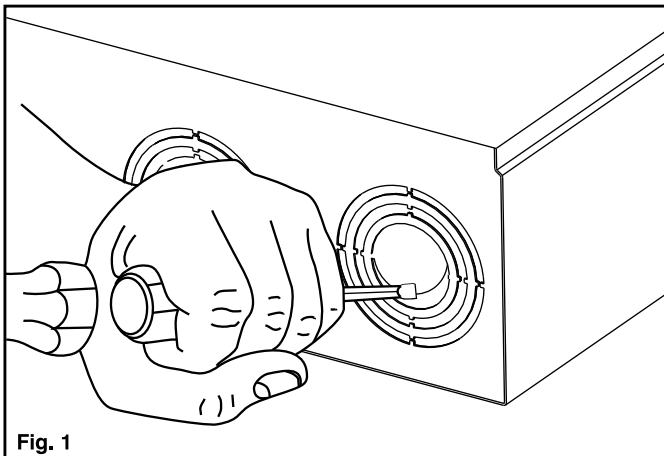

Mount Enclosure

For semi-flush mounting (WEP series only), Flange Kits are available for purchase. Using these flanges, secure device at proper location (Fig.3). Building paper or flashing must cover these flanges.

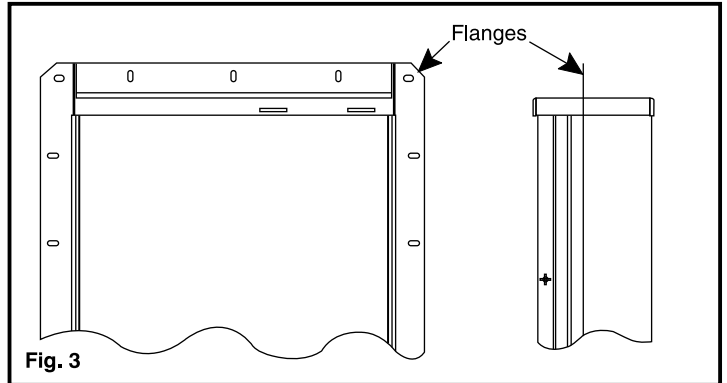

For Surface Mounting, mount Alignment Rails* (supplied). Determine proper mounting height so that the meter height is in accordance with local codes. Refer to Fig. 5 for dimension from top of device to Alignment Rail Mounting Screws. Mount alignment rail(s) as shown in Fig. 4 (Mounting screws supplied by installer).

Hang Enclosure by slipping the Mounting Bracket on the back of the device over the Alignment Rail as shown in Fig. 5. Secure enclosure to wall with screws (supplied by installer).

* For surface mounting devices with 2 meter positions, alignment rails are not required. Use mounting embosses provided on back surface of enclosure.

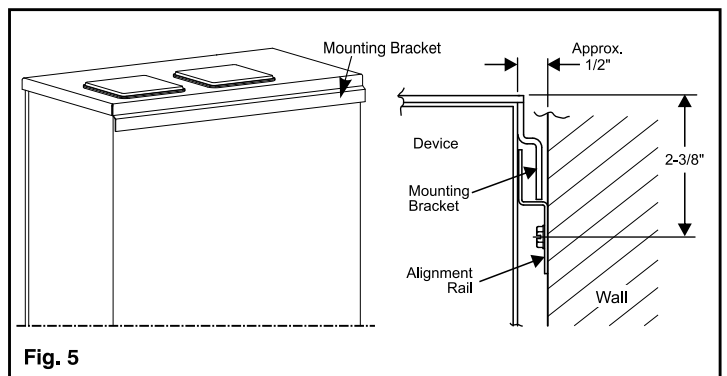
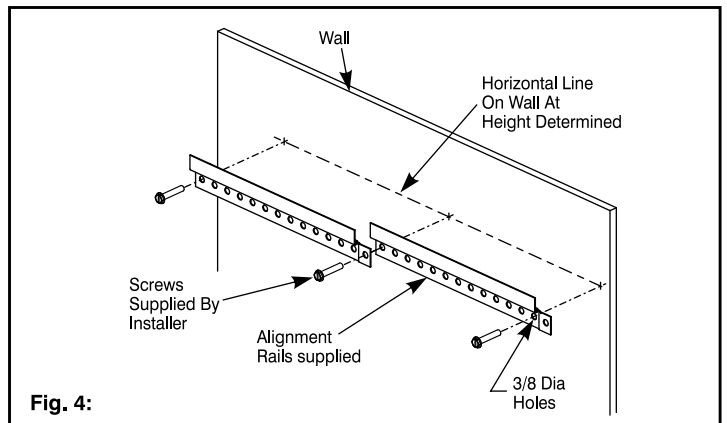

Pull Cable - Wire Main

Pull wire/cable into box and utilize proper fittings to secure and provide proper protection to conductor insulation.

Wire main terminals in pull section. When aluminum conductors are used, the application of a UL-Listed conductor termination compound is recommended. Refer to wiring diagram label inside device for proper terminal tightening torque requirements. Provision for equipment ground is provided in the customer section.

Install And Wire Breakers

Install and wire correct type circuit breakers in accordance with wiring diagram label requirements.

See Fig. 6 for breaker installation and removal guidelines. When aluminium conductors are used, the application of a UL-Listed conductor termination compound is recommended. See branch breakers for wire size and tightening torque requirements. All electrical connections must be tightened to requirements as specified on wiring diagram label and on each circuit breaker label before energizing.

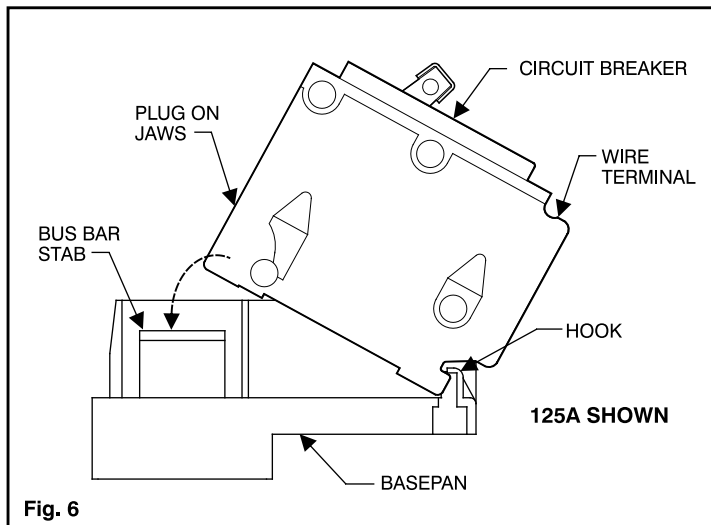

Positioning of 5th Jaw for Plug-In Meter Sockets (if applicable)

When factory installed, the 5th jaw will be located in the 9 o'clock position. To change to the 6 o'clock position, loosen the 5th Jaw Mounting Screw, push on 5th Jaw Locking Tab and remove 5th jaw assembly. Hook forked end of 5th jaw assembly under 5th Jaw Mounting Screw and snap 5th jaw assembly in 6 o'clock position. Tighten 5th Jaw Mounting Screw to 15-20 lb-ins. See Fig. 7.

For replacement part and accessory part numbers see wiring diagram inside of unit.

