

## Catalog Numbers

Catalog No.	Amperage Rating	Max. Interrupting Rating
<b>3 PHASE, 4 WIRE, 240V AC MAX</b>		
WB3900T	900	65,000
WB3900TU	900	100,000
WB31000T	1000	65,000
WB31000TU	1000	100,000
WB31200T	1200	65,000
WB31200TU	1200	100,000

- TYPE 3R OUTDOOR ENCLOSURE
- MAIN BUS RATING: 1200A MAX., 240V AC Max.
- 3 PHASE
- FOR OVERHEAD SERVICE ONLY
- MOUNTING RAILS AND ADJUSTABLE BRACKETS FOR SECURE MOUNTING

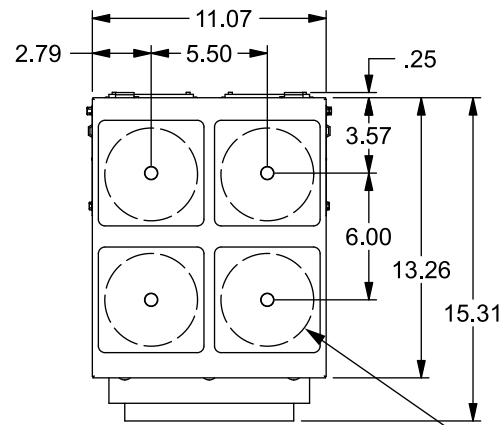

FRONT VIEW SHOWN WITH COVER AND SHIELDS REMOVED

(4) TYPE "HD" 4" MAX HUB OPENINGS, FACTORY INSTALLED COVER PLATES

## Accessories

Ground Bar Kit . . . . .	ECLX069M
Ground Lug Kit (3 Position) . . . . .	ECGLK3300, (3) #6-300kcmil, Torque 250 lb-in
Ground Lug Kit (6 Position) . . . . .	ECGLK6300, (6) #6-300kcmil, Torque 250 lb-in
Breaker Lug Kit (factory installed) . . . . .	LK34500 (kit includes 4 lugs)
Alternate Breaker Lug Kit . . . . .	LK33750 - (3) 500-750 kcmil, Torque 375 lb.-in. (kit includes 4 lugs)

Equip Ground Acc'y Cat. No. ECLX069M	
Small Terminals	Large Terminals
Wire Range / Torque	Wire Range / Torque
10-14 AWG 20 lb-in	10-14 AWG 35 lb-in
8 AWG . . . . 25 lb-in	8 AWG . . . . 40 lb-in
6 AWG . . . . 35 lb-in	1/0-6 AWG . 45 lb-in

HD Type Hubs	Catalog No.
Hub Cover Plate	EC56933S
Type HD Hub 2"	EC56854
Type HD Hub 2-1/2"	EC56855
Type HD Hub 3"	EC56856
Type HD Hub 3-1/2"	EC56857
Type HD Hub 4"	EC56858

## Additional Modules

**IMPORTANT - for use with:**

Module Description	Siemens Series#
Main Breakers	WB(M), WEB(M), WXB, BFT
Switches	WMP, WS, WES, WXS
Tap/Terminal Boxes	WTB, WET, WT_PU, WTBN, WBT
Pull Boxes	WMMB
Meter Module	(W)MM, (W)MT, (W)ML, (W)MK, (W)MLZ(F), (W)MN
Meter Combinations	WC, WCL, WCT,
Extension Box	WSP, WSPD
Bussed Elbow	BE, WELB

Connect Modules Using:	Catalog Number / Torque
QuickConnect	QC4, Torque 400-440 lb-in (35-36 ft.-lb.)

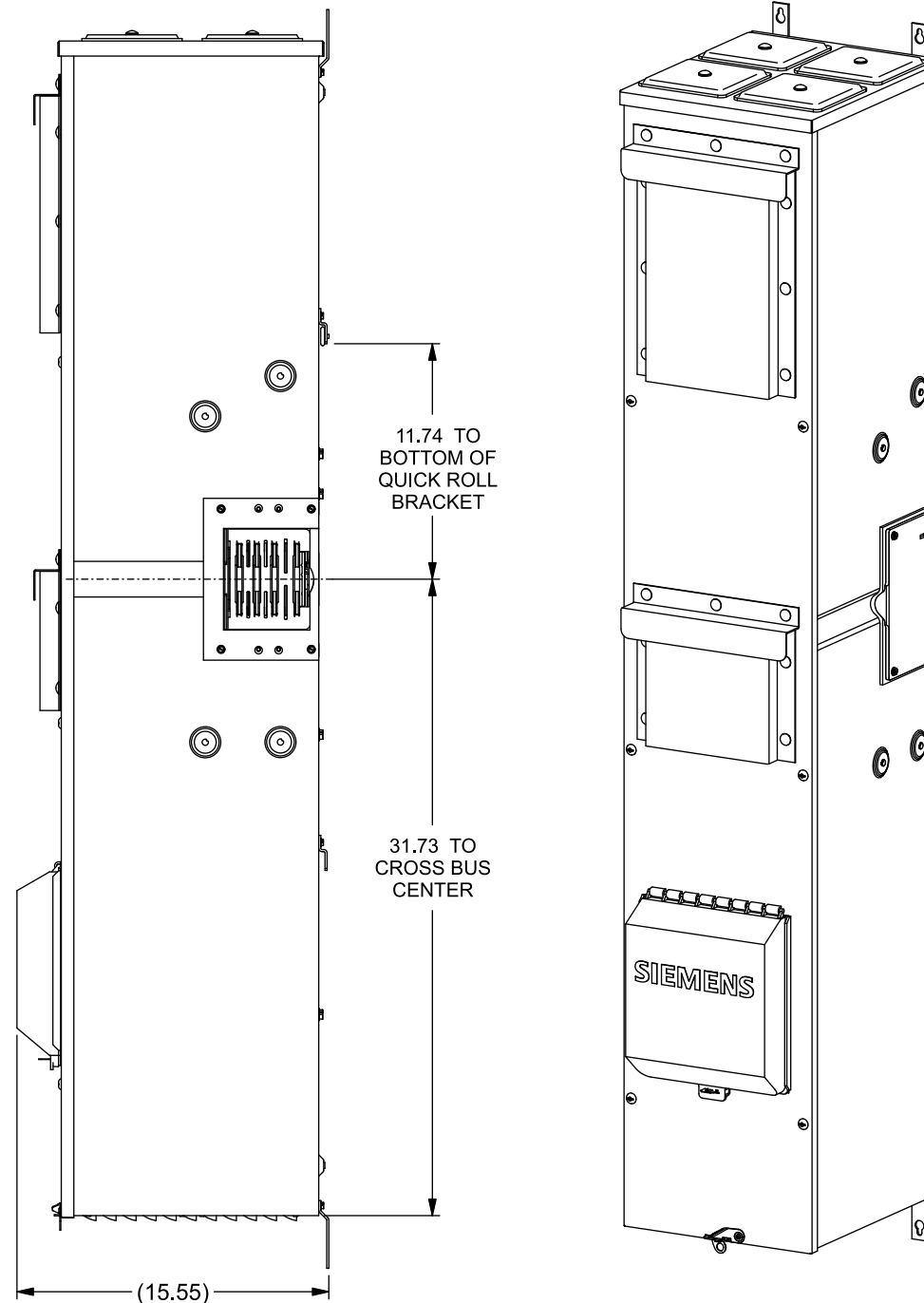
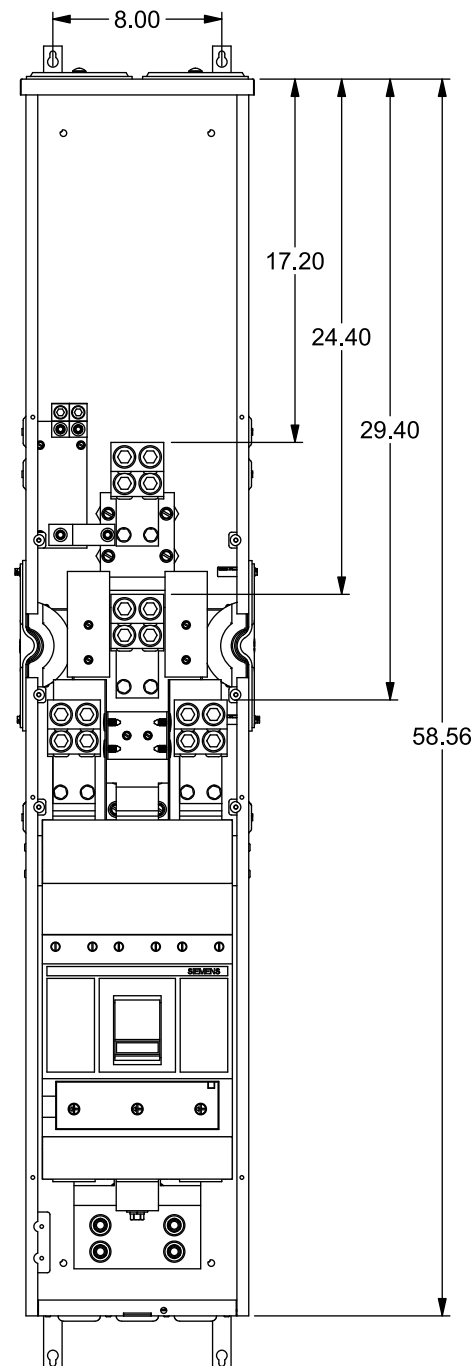
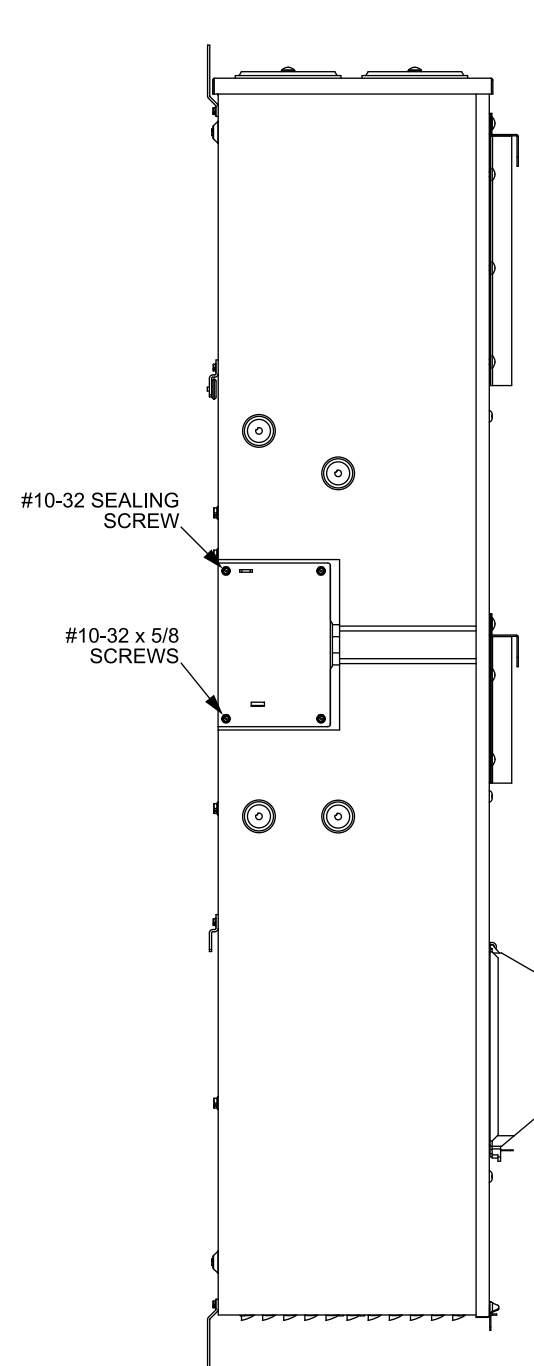

## Schematic

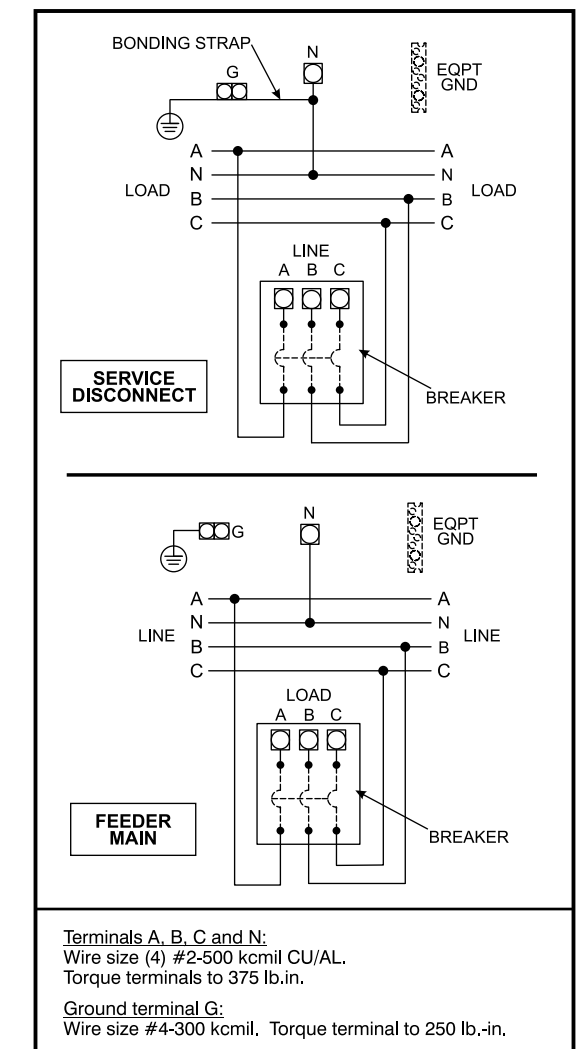

© 2018 Copyright Siemens Industry, Inc.

**SIEMENS**  
Siemens Industry, Inc.

**PowerMod™ Breaker Mains**

Description: **900-1200A, 3 Phase, Top Feed Skinny Mains**

KAM 8/6/18 DO NOT SCALE DRAWING Dwg. No. **WB3900T-WB31200TU**